

Heinz Tschätsch

Applied Machining Technology

 Springer

Applied Machining Technology

Heinz Tschätsch

Applied Machining Technology



Springer

Author

Prof. Dr.-Ing. Heinz Tschätsch
Paul-Gerhard-Str. 25
01309 Dresden
Germany

Translator

Dr.-Ing. Anette Reichelt
Technik und Sprache
Ernst-Enge-Straße 112
09127 Chemnitz
Germany
technik.und.sprache@t-online.de

ISBN 978-3-642-01006-4 e-ISBN 978-3-642-01007-1
DOI 10.1007/978-3-642-01007-1
Springer Dordrecht Heidelberg London New York

Library of Congress Control Number: 2009928829

Translation from the German language edition: *Praxis der Zerspantechnik* by Heinz Tschätsch, 8th edition: © Vieweg 2008. All rights reserved

© Springer Science+Business Media, LLC 2009

All rights reserved. This work may not be translated or copied in whole or in part without the written permission of the publisher (Springer Science+Business Media, LLC, 233 Spring Street, New York, NY 10013, USA), except for brief excerpts in connection with reviews or scholarly analysis. Use in connection with any form of information storage and retrieval, electronic adaptation, computer software, or by similar or dissimilar methodology now known or hereafter developed is forbidden.

The use in this publication of trade names, trademarks, service marks, and similar terms, even if they are not identified as such, is not to be taken as an expression of opinion as to whether or not they are subject to proprietary rights.

While the advice and information in this book are believed to be true and accurate at the date of going to press, neither the authors nor the editors nor the publisher can accept any legal responsibility for any errors or omissions that may be made. The publisher makes no warranty, express or implied, with respect to the material contained herein.

Cover design: WMXDesign GmbH, Heidelberg

Printed on acid-free paper

Springer is part of Springer Science+Business Media (www.springer.com)

Preface

A central issue on which industrial manufacturing is focused is that of metal cutting techniques.

However, given the state of the art in metal cutting, it is impossible in a single book to introduce every method. Instead, the author of this textbook has deliberately chosen to leave out the techniques for gear tooth generation. Following a brief introduction to the basics of metal cutting, all methods will be classified using the same approach and described as briefly as possible in the text.

The tables with guide values are provided to aid in working with this book in teaching and practice. The summarised guide values should be seen as reference figures that provide an initial orientation. More exact values can be obtained from the cutting tool manufacturers themselves. These values are the only ones that are binding, since they correspond to specific products and are determined according to the cutting edge materials used, the cutting edge geometry, and whatever conditions obtain at the manufacturers' firms.

This book is intended both for students of all kinds at technical colleges and universities and for those working in the industry.

Due to the clarity of its structure and explanations, it is also suitable for technical high schools and vocational schools.

For practical use, it is designed as a compendium for quick information.

Students may use this book as a tutorial text that takes the place of note-taking during the lecture, allowing them to devote their full attention to listening in the auditorium.

Also, every user of this book has the opportunity to compare the earlier DIN notation with the new material denominations that follow the European standards.

He or she is thus free to use either the older names, which are of course still valid, or the new ones.

Other subjects that have been added to the book's content are

- High-speed cutting (abbreviation HSC), which is becoming more and more important in industrial manufacturing, and two typical HS machining centres
- Advanced coolants and metalworking fluids for machining
- Advanced methods of force measurement and applicable measuring devices for turning and drilling
- Wire cut lapping.

I am especially grateful to my colleague Prof. Dr.-Ing.; Prof. h. c.. Jochen Dietrich, professor in manufacturing techniques and CNC technology at the University of Applied Sciences, Dresden, who was a co-author of this book beginning with the 6th edition.

I would also like to thank my editor, Dipl.-Ing. Thomas Zipsner of Vieweg Publishing, who gave me a great deal of help in redesigning and correcting the 8th edition.

Terms, formulae and units

Parameter	Formula	Unit
Depth of cut or width of cut	a_p	mm
Cutting engagement	a_e	mm
Thickness of cut	H	mm
Mean thickness of cut	H_m	mm
Width of cut	B	mm
Sectional area of chip	A	mm ²
Feed per tooth	f_z	mm
Feed per revolution	$f(s)$	mm
Number of cutting edges	z_E	–
Speed	N	min ⁻¹
Feed rate	$v_f(u)$	mm/min
Feed rate (tangential)	V_t	mm/min
Cutting speed	V_c	m/min
Cutting speed for turning at $f = 1 \text{ mm/U}$, $a_p = 1 \text{ mm}$, $T = 1 \text{ min}$	$v_{c1.1.1}$	m/min
Specific cutting force related to $h = 1 \text{ mm}$, $b = 1 \text{ mm}$	$k_{c1.1}$	N/mm ²
Specific cutting force	K_c	N/mm ²
Material constant (exponent)	Z	–
Resultant cutting force	F	N
Feed force	F_f	N
Passive force	F_p	N
Major cutting force	F_c	N
Torque	M	Nm
Effective power	P_e	kW
Cutting power	P_c	kW
Feed power	P_f	kW
Machine input power	P	kW

Parameter	Formula	Unit
Machine efficiency	η	–
Tool life (turning)	T	min
Tool life travel path (drilling, milling)	L	M
Workpiece volume	Q_w	mm ³ /min
Metal removal rate (volume of disordered chips)	Q_{sp}	mm ³ /min
Chip volume ratio	R	–
Surface roughness (max. peak-to-valley height)	R_t	μm
Mean surface roughness (arithmetic mean out of 5 measuring values)	R_z	μm
Peak radius at turning tool	r	mm
Machining time	t_h	min
Workpiece length	l	mm
Approach	l_a	mm
Overrun	l_u	mm
Total path	L	mm
Milling cutter diameter	D	mm
Grinding wheel diameter	D_s	mm
Drill- or workpiece diameter	d	mm
Rake angle	γ	° (degree)
Tool orthogonal clearance	α	° (degree)
Wedge angle	β	° (degree)
Tool cutting -edge angle	χ	° (degree)
Angle of inclination	λ	° (degree)
Drill-point angle (drill)	σ	° (degree)
Feed motion angle (milling) Dihedral angle (turning)	φ	° (degree)
Cutting direction angle	η	° (degree)
Chamfer clearance angle (primary clearance)	α_f	° (degree)
Chamfer rake angle	γ_f	° (degree)

Contents

1	Introduction	1
1.1	The methods of metal cutting	1
1.2	Characteristics of metal cutting	1
1.2.1	Crystalline alteration of the material	1
1.2.2	Changes in strength	1
1.2.3	Stress relief	1
1.2.4	Reduction of strength due to the cutting through of fibres	1
1.2.5	Substantial material loss	1
1.3	Formation of the cutting edges	2
1.3.1	Tools with defined cutting edge geometry	2
1.3.2	Tools with undefined cutting edge geometry	2
1.4	Cutting conditions (depth of cut a_p , feed f and cutting speed v_c)	2
1.5	Cutting force	2
1.6	Chips	3
1.7	Chip shapes	3
1.8	Cutting edge materials	3
2	Fundamentals of machining explained for turning	5
2.1	Surfaces, cutting edges, and corners on wedges according to DIN 6581	5
2.1.1	Flank faces	5
2.1.2	Rake faces	5
2.1.3	Cutting edges	6
2.1.4	Corners	6
2.2	Reference planes	6
2.2.1	Tool reference plane 1	7
2.2.2	Cutting edge plane 2	7
2.2.3	Wedge measuring plane 3	7
2.2.4	Working plane 4	7
2.3	Angles for the wedge	7
2.3.1	Angles measured in the tool reference plane (Figure 2.3)	7
2.3.2	Angle measured in the cutting edge plane Tool cutting edge inclination λ (Figure 2.4)	7
2.3.3	Angles measured in the wedge measuring plane (Figure 2.5)	8

2.4	Angle types and their influence on the cutting procedure.	9
2.4.1	Tool orthogonal clearance α	9
2.4.2	Rake angle γ	12
2.4.3	Wedge angle β	13
2.4.4	Tool cutting edge angles κ	13
2.4.5	Tool included angle ε (Figure 2.14)	14
2.4.6	Tool cutting edge inclination λ	15
2.4.7	Working reference plane	15
2.5	Cutting parameters	16
2.5.1	Width of cut b	16
2.5.2	Thickness of cut h	17
2.5.3	Sectional area of chip A	17
2.6	Cutting forces and their origin	17
2.6.1	Generation of forces	17
2.6.2	Specific cutting force k_c and its influencing variables	18
2.6.3	Major cutting force F_c	21
2.7	Calculation of power.	22
2.7.1	Cutting power P_c	22
2.7.2	Machine input power P	23
3	Tool life T	25
3.1	Definition	25
3.2	Characteristics of dulling	25
3.2.1	Cutting materials for which dulling is mainly caused by temperature	25
3.2.2	Cutting materials for which dulling is mainly caused by abrasion	25
3.2.3	Wear types	25
3.3	Influence on tool life	27
3.3.1	Workpiece material	27
3.3.2	Cutting material	27
3.3.3	Cutting edge shape	28
3.3.4	Surface	28
3.3.5	Stiffness	28
3.3.6	Sectional area of chip	28
3.3.7	Coolants and lubricants	28
3.3.8	Cutting speed	28
3.4	Calculation and representation of tool life	28
3.5	Length of tool life and allocation of the cutting speed	30
3.6	Cost-optimal tool life	31
4	Tool- and machine curves	33
4.1	Tool curve	33
4.2	Machine curve	34
4.3	Optimum cutting range	36

5	Metal removal rate and chip volume ratio	39
5.1	Metal removal rate	39
5.2	Chip shapes	39
5.2.1	Transportability	40
5.2.2	Danger for the machine operator	40
5.3	Chip volume ratios	40
6	Cutting materials	43
6.1	Unalloyed tool steels	43
6.2	High speed steels	43
6.3	Cemented carbides	45
6.4	Ceramics	46
6.5	Diamond tools	47
7	Turning	51
7.1	Definition	51
7.2	Turning technology	51
7.2.1	Cylindrical turning	51
7.2.2	Facing	51
7.2.3	Parting	52
7.2.4	Form turning	53
7.2.5	Taper turning	53
7.2.6	Copy turning	54
7.2.7	Turning with numerical control (NC, CNC)	56
7.2.8	Thread turning	57
7.2.9	Application of turning methods	58
7.3	Achievable accuracy values using turning	58
7.3.1	Dimensional accuracy values	58
7.3.2	Surface roughness	58
7.4	Chucking devices	60
7.4.1	to chuck the workpieces	60
7.4.2	Clamping devices to fix the tools	66
7.5	Calculation of power and forces	68
7.5.1	Width of cut b (Figure 2.15)	68
7.5.2	Thickness of cut h	68
7.5.3	Sectional area of chip A	68
7.5.4	Specific cutting force K_c	69
7.5.5	Major cutting force F_c	69
7.5.6	Cutting speed v_c	69
7.5.7	Machine input power P	69
7.6	Determination of machining time t_h	70
7.6.1	Cylindrical turning	70
7.6.2	Facing	71
7.6.3	Thread turning	72
7.7	Determination of the cycle time	72

7.8	Turning tools	73
7.8.1	Tool design types	73
7.8.2	Chip-breaking shoulders	80
7.8.3	Chamfers on the turning tool	83
7.9	Failures in turning	84
7.9.1	Tool failures	84
7.9.2	Workpiece failures	84
7.10	Reference tables	85
7.11	Examples of calculation:	92
8	Planing and slotting	97
8.1	Definition	97
8.2	Planing- and slotting methods	97
8.2.1	Shaping	97
8.2.2	Slotting	97
8.3	Application of the techniques	98
8.3.1	Shaping	98
8.3.2	Slotting (vertical planing)	98
8.4	Accuracy values achievable with planing	98
8.5	Determination of force- and power	99
8.5.1	Calculation of force	99
8.5.2	Machine input power for shaping machines	99
8.5.3	Machine input power for parallel planing machines	100
8.6	Calculation of the machining time	100
8.6.1	Speeds in planing	100
8.6.2	Number of strokes per unit of time	101
8.6.3	Length- and width values that are considered in time calculations	101
8.6.4	Machining time for planing	102
8.7	Reference table	103
8.8	Example of calculation	103
9	Drilling	105
9.1	Definition	105
9.2	Drilling methods	105
9.2.1	Centre drilling	105
9.2.2	Drilling out – boring (Figure 9.2)	105
9.2.3	Counterboring	107
9.2.4	Reaming	107
9.2.5	Thread cutting with taps	107
9.3	Generation and purpose of holes	107
9.3.1	Blind holes (Figure 9.4)	107
9.3.2	Through hole (Figure 9.5)	107
9.3.3	Tapered holes (Figure 9.6)	108

9.3.4	Counterbores (Figure 9.7)	108
9.3.5	Tapped hole (Figure 9.8)	108
9.4	Accuracies feasible with drilling	109
9.5	Calculation of forces, torque and power	109
9.5.1	Centre drilling (Figure 9.9)	110
9.5.2	Drilling out (Figure 9.11)	112
9.5.3	Counterboring (Figure 9.12)	113
9.5.4	Reaming	115
9.5.5	Thread cutting with taps	115
9.6	Calculation of machining time (machine time)	115
9.6.1	Centre drilling	116
9.6.2	Drilling out with twist drill	117
9.6.3	Spot facing	117
9.6.4	Thread cutting	118
9.7	Drilling tools	119
9.7.1	Twist drill	119
9.7.2	Helical counterbore	127
9.7.3	Spot facers, countersinks and special-shape countersinkers	129
9.7.4	Centre drills	130
9.7.5	Boring tools	132
9.7.6	Reaming tools	133
9.7.7	Taps	136
9.8	Failures in drilling	139
9.8.1	Tool failures	139
9.8.2	Workpiece failures	139
9.9	Reference values for drilling methods	140
9.10	Examples	143
10	Sawing	147
10.1	Definition	147
10.2	Sawing methods	147
10.2.1	Sawing with saw blade	147
10.2.2	Sawing with endless belt-saw blades	147
10.2.3	Sawing with circular saw blades	147
10.3	Sawing methods - tasks and ranges of application	148
10.4	Accuracy values achievable with sawing	149
10.5	Calculation of forces and power	149
10.5.1	Laws valid for all sawing methods	149
10.5.2	Calculations for sawing with saw blade or saw band	151
10.5.3	Calculations for sawing with circular saw blade	152
10.6	Calculation of machining time	153
10.6.1	Sawing with circular saw blade of rectangular section (Figure 10.8)	154
10.6.2	Sawing with saw blade or saw band	155
10.7	Sawing tools	155

10.7.1	Angles and pitch for saw tooth	155
10.7.2	Sawing tools - tooth forms and design types	156
10.7.3	Saw blade materials	164
10.8	Failures in sawing	165
10.9	Reference tables	167
10.10	Examples.	170
11	Milling	173
11.1	Definition	173
11.2	Milling techniques.	173
11.2.1	Peripheral milling	173
11.2.2	Face milling.	174
11.2.3	Form milling	175
11.2.4	Groove milling	176
11.3	Application of the milling techniques	178
11.3.1	Peripheral milling	178
11.3.2	Face milling.	178
11.3.3	Form milling	179
11.3.4	Groove milling	179
11.4	Accuracies achievable with milling	179
11.5	Calculation of force and power.	179
11.5.1	Peripheral milling	179
11.5.2	Face milling.	183
11.5.3	Simplified calculation of the volume removal rate for peripheral and face milling	187
11.6	Machining times during milling	188
11.6.1	Peripheral milling	188
11.6.2	Face milling.	189
11.6.3	Groove milling	190
11.6.4	Short-thread milling	191
11.6.5	Long-thread milling	191
11.7	Milling cutters.	191
11.7.1	Cutting edge forms and teeth number on the milling cutter	191
11.7.2	Flute direction, helix angle and cutting direction of the milling cutter.	192
11.7.3	Cutting edge geometry on milling cutters.	193
11.7.4	Plain milling cutters – design variants and ranges of application	196
11.7.5	Cutter heads.	204
11.7.6	Tool holders for plain milling cutters	207
11.7.7	Mounting and fastening of cutter heads	211
11.7.8	Cutting materials.	212
11.8	Failures during milling	213
11.9	Reference tables	214
11.10	Examples.	217
11.11	Gear machining techniques.	222

12 Broaching	225
12.1 Definition	225
12.2 Broaching methods	225
12.2.1 Internal broaching	225
12.2.2 External broaching	225
12.3 Application of the broaching techniques	226
12.3.1 Internal broaching	226
12.3.2 External broaching	227
12.4 Achievable accuracy values	227
12.4.1 Accuracy to size	227
12.4.2 Surface quality	228
12.5 Calculation of force and power	228
12.5.1 Width of cut b (Figure 12.5)	229
12.5.2 Thickness of cut h	229
12.5.3 Specific cutting force	229
12.5.4 Major cutting force per cutting edge	230
12.5.5 Number of teeth in contact	230
12.5.6 Toothing pitch	230
12.5.7 Major cutting force	232
12.5.8 Machine input power	232
12.6 Calculation of the machining time	232
12.6.1 Work cycle during internal broaching (Figure 12.7)	233
12.6.2 Working stroke during external broaching (Figure 12.8)	233
12.6.3 Length of the cutting portion (Figure 12.7)	234
12.7 Broaching tools	234
12.7.1 Broach – blade geometry	234
12.7.2 Broach teeth design	235
12.7.3 Materials for broaching tools	241
12.8 Failures during broaching	243
12.8.1 Tool failure	243
12.8.2 Workpiece failures	244
12.9 Reference tables	244
12.10 Calculation example	244
13 Grinding	249
13.1 Definition	249
13.2 Grinding techniques	249
13.2.1 Flat grinding	249
13.2.2 Cylindrical grinding	252
13.2.3 Cutting data for flat grinding and cylindrical grinding with clamped workpiece	256
13.2.4 Centreless grinding	257
13.3 Application of grinding techniques	261
13.3.1 Flat grinding	261
13.3.2 Cylindrical grinding	262
13.4 Achievable accuracy values and allowances during grinding	264

13.5	Calculation of force and power	264
13.6	Calculation of the machining time	268
13.6.1	Flat grinding	268
13.6.2	External- and internal cylindrical grinding	270
13.6.3	Centreless grinding	271
13.7	Grinding wheels	272
13.7.1	Tool materials	272
13.7.2	Design types and denomination of grinding wheels	276
13.7.3	Wheel mounting	280
13.7.4	Grinding wheel selection for special ranges of application	281
13.8	Failures during grinding	282
13.8.1	Parameters influencing the grinding procedure	282
13.8.2	Table of failures	283
13.9	Reference tables	283
13.10	Calculation examples	289
14	Abrasive cutting	295
15	Abrasive belt grinding	297
15.1	Application of the abrasive belt grinding method	298
16	Honing	301
16.1	Application of the honing procedure	306
16.2	Achievable accuracies and allowances	307
17	Superfinishing (shortstroke honing)	309
17.1	Application of superfinishing	309
18	Lapping	311
18.1	Application of the lapping technique	312
18.2	Dicing (wire cutting with slurry)	312
19	Further refinement of the cutting materials	317
19.1	High-speed steels	317
19.2	Cemented carbides	317
19.2.1	Uncoated cemented carbides	317
19.2.2	Cermets	318
19.2.3	Coated cemented carbides	318
19.3	Ceramic	322
19.3.1	Oxide ceramic, white (clean ceramic)	322
19.3.2	Oxide ceramic, black (mixed ceramic)	322
19.3.3	Nitride ceramic	322
19.3.4	Whisker ceramic	322
19.3.5	Coated ceramic	322

19.4	Polycrystalline cutting materials.	323
19.4.1	Polycrystalline diamond (PCD)	323
19.4.2	Cubic boron nitride (CBN)	323
19.5	Marking of (hard) cutting materials	323
20	High speed cutting (HSC)	325
20.1	Definition	325
20.2	Introduction to high speed cutting (HSC).	325
20.3	Application of high speed cutting	327
20.3.1	High speed cutting techniques	327
20.3.2	HSC machines.	328
20.3.3	Tools for high speed milling	336
20.3.4	Reference cutting parameters for high speed-milling- and - turning.	341
21	Cutting fluids (coolants and lubricants)	349
21.1	Introduction.	349
21.2	Wet cutting	349
21.3	Minimum quantity cooling lubrication (MQL).	350
21.4	Dry cutting	352
22	Cutting force measurement in machining	353
22.1	Introduction.	353
22.2	Force measurement during turning	354
22.3	Force measurement during drilling and milling	355
22.4	Force measurement during broaching.	358
23	Tables for general use	361
24	Appendix	373
24.1	Test questions	373
24.2	Comparison of old (German standard DIN) and new (European standard) material names	377
24.3	Firm addresses	382
	References	387
	Glossary	395

1 Introduction

1.1 The methods of metal cutting

are:

1.1.1 Methods of finishing

1.1.2 They are used when efficiency is called for, predominantly after forming to preshape the workpiece.

1.2 Characteristics of metal cutting

1.2.1 Crystalline alteration of the material

During chip removal, the crystallites are either unchanged or changed only on the surface in the immediate vicinity of the chip removal.

1.2.2 Changes in strength

In most cases, strain hardening in the marginal zones is small as to be negligible.

1.2.3 Stress relief

During metal cutting, under certain circumstances, stresses resulting from, for example, cold working inside the workpiece are relieved.

Stress is also relieved in castings and forgings, or in parts subjected to heat treatment, when cutting marginal zones whose hardness or carbon content differs from that of the core material. The latter may result in workpiece distortion.

1.2.4 Reduction of strength due to the cutting through of fibres

Whereas in forming, for example, the fibre structure is maintained, and the fibre configuration adapts itself to the outer workpiece contour (for instance, in thread rolling), in metal cutting, the fibre is cut through. As a result, strength is reduced in many cases.

1.2.5 Substantial material loss

In metal cutting, the blank diameter has to correspond to the maximal diameter of the part to be manufactured. An allowance is added to this diameter. To machine the bolt (Figure 1), when using rolled material, the blank should have a size of approximately 100 mm (diameter) and 185 mm (length).

When the weights of finished part and the blank are compared, it can be seen that 46% of the blank weight is removed in generating the workpiece.

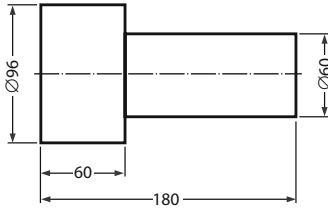


Figure 1.1
Shear connector, made of St 50
46% of the initial blank weight is removed

1.3 Formation of the cutting edges

Metal cutting tools are categorised as:

1.3.1 Tools with defined cutting edge geometry

All of these tools have a shape that is clearly defined in terms of geometry. These tools include turning tools, milling cutters, saw blades, planing tools etc.

1.3.2 Tools with undefined cutting edge geometry

In these tools, the cutting edges are arranged randomly in an undefined manner. Tools of this kind include all grinding tools with bond (grinding wheels) or loose (lapping abrasive) grid.

1.4 Cutting conditions (depth of cut a_p , feed f and cutting speed v_c)

Select the cutting conditions for metal removal so that:

- the required machine input power is utilised in an optimal manner
- tool life is maintained reasonably well and
- cutting time is kept short.

A “reasonable” tool life mainly results from the cutting time per workpiece and the time necessary for the tool change. In the case of very expensive machines, it is necessary to calculate the most cost-efficient way to maintain tool life (see Chapter 2.8.7) to determine economical cutting conditions.

1.5 Cutting force

At any given cross section of the chip, the cutting force should be kept to a minimum through the right choice of cutting conditions. The smaller the cutting force, the lower the stresses inside the tool and the machine.

Attention should be paid to ensuring that the force diminishes as cutting speed increases in the working range of high-speed steels (compare Chapter 2.6.5.). As

a rule, the limits of permissible cutting speed for high-speed steels should not be exceeded under any circumstances.

1.6 Chips

If possible, the chips should be fractured into short pieces since in this form they are less dangerous for the operator of the machine and may be handled and processed more easily.

1.7 Chip shapes

The shape of the chips formed during metal removal (see Chapter 5.2) depends on the materials being cut and the cutting conditions.

The volume of chips that is to be transported is sorted by specific chip shapes; these are assigned identification numbers R (R for chip space number).

1.8 Cutting edge materials

The following materials are used as cutting edge materials:

- high-performance high-speed steels
- cemented carbides
- ceramics
- diamonds.

Materials that are particularly significant at present are coated cutting edge materials, in which the basic material is coated with thin layers of an especially hard and wear-resistant material, such as coronite (based on TiCN or TiN). Thus, for example, cubic boron nitride is the second hardest substance after diamond. It has high heat hardness (up to 2000 °C) and is brittle, but tougher than ceramics.

2 Fundamentals of machining explained for turning

The terms of machining, as well as tool wedge geometry are defined in the DIN standards 6580 and 6581.

This chapter provides a summary of the most essential data found in these DIN sheets that relate to the turning procedure. These data can be applied to other techniques.

2.1 Surfaces, cutting edges, and corners on wedges according to DIN 6581

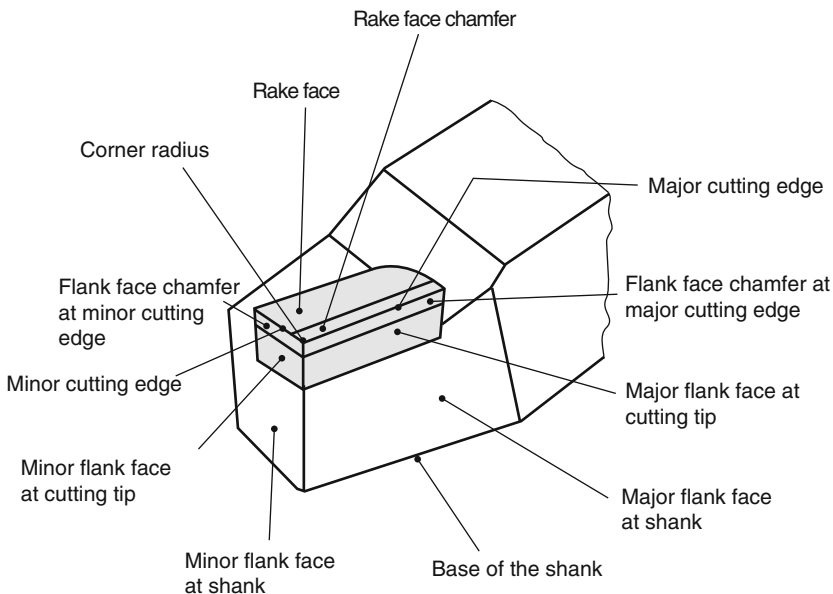


Figure 2.1
Surfaces, cutting edges, and corners on wedges

2.1.1 Flank faces

are those areas on the wedge that are turned toward the cut surfaces. If a flank face is chamfered, then it is called a flank face chamfer.

2.1.2 Rake faces

are the surfaces over which the chip passes.

If a rake face is chamfered, then it is called a rake face chamfer.

2.1.3 Cutting edges

2.1.3.1 Major cutting edges

are defined as those cutting edges whose wedge, when viewed in the working plane, points in the direction of the feed motion.

2.1.3.2 Minor cutting edges

are defined as cutting edges whose wedge in the working plane does not point in the direction of the feed motion.

2.1.4 Corners

2.1.4.1 Cutting edge corner

defines the corner at which major- and minor cutting edges meet the common rake face.

2.1.4.2 Corner radius

is the rounding of the corner (corner radius r is measured in the tool reference plane).

2.2 Reference planes

In order to define the angles for the wedge, we assume an orthogonal reference system (see Figure 2.2).

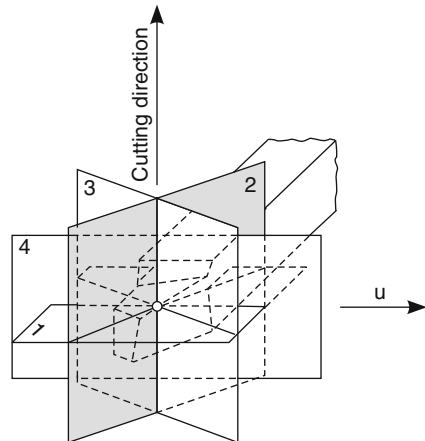


Figure 2.2
Reference system to define the angles for the wedge

The reference system consists of 3 planes: tool reference plane, cutting edge plane and wedge measuring plane.

The working plane was introduced as an additional auxiliary plane.

2.2.1 Tool reference plane 1

is defined as a plane through the observed cutting edge point, normal to the direction of primary motion and parallel to the cantilever plane.

2.2.2 Cutting edge plane 2

is a plane including the major cutting edge, normal to the tool reference plane.

2.2.3 Wedge measuring plane 3

describes a plane that is orthogonal to the cutting edge plane and normal to the tool reference plane.

2.2.4 Working plane 4

is a virtual plane, containing the direction of primary motion and the direction of feed motion., The motions involved in chip formation are performed in this plane.

2.3 Angles for the wedge

2.3.1 Angles measured in the tool reference plane (Figure 2.3)

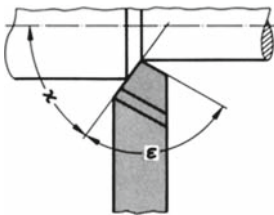


Figure 2.3
tool cutting edge angle α ;
tool included angle ϵ

2.3.1.1 Tool cutting edge angle α

refers to the angle between the working plane and the cutting edge plane.

2.3.1.2 Tool included angle ϵ

is defined as the angle situated between the primary- and secondary cutting edges.

2.3.2 Angle measured in the cutting edge plane **Tool cutting edge inclination λ** (Figure 2.4)

describes the angle between the tool reference plane and the major cutting edge.

Tool cutting edge inclination is negative in cases where the cutting edge rises from the top. It determines the point on the cutting edge at which the tool first penetrates the material.

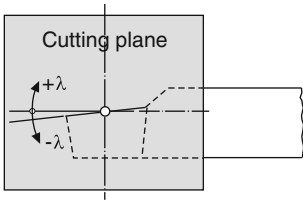


Figure 2.4
Tool cutting edge inclination λ

2.3.3 Angles measured in the wedge measuring plane (Figure 2.5)

2.3.3.1 Tool orthogonal clearance α

is defined as the angle between flank face and cutting edge plane.

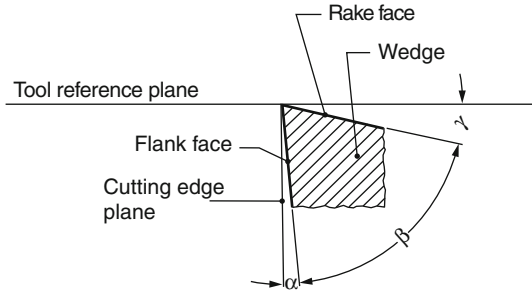


Figure 2.5
Tool orthogonal clearance α ; wedge angle β ; rake angle γ

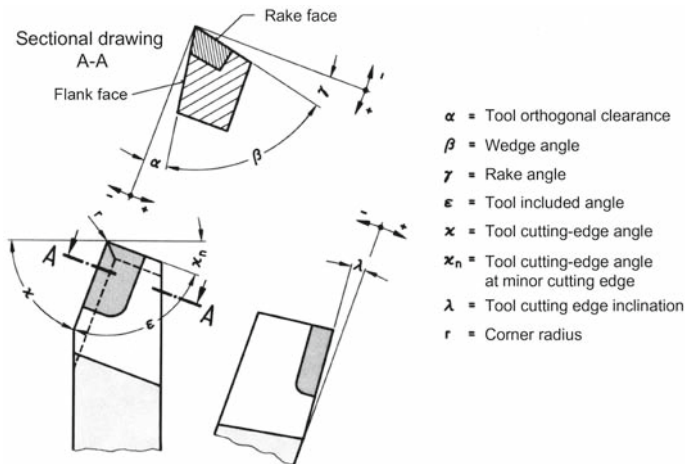


Figure 2.5a
Overview showing the most significant angles on the wedge

2.3.3.2 Wedge angle β

is defined as the angle between flank - and rake face.

2.3.3.3 Rake angle γ

is the angle between rake face and tool reference plane.

Following equation showing the relationship between these three angles is valid in any case:

$$\alpha + \beta + \gamma = 90^\circ$$

If the faces are chamfered (Figure 2.6), then the angles of chamfer are given the following notation:

Chamfer clearance angle (primary clearance) α_f

Chamfer wedge angle β_f

Chamfer rake angle γ_f

Even in this case, the following relationship is valid:

$$\alpha_f + \beta_f + \gamma_f = 90^\circ$$

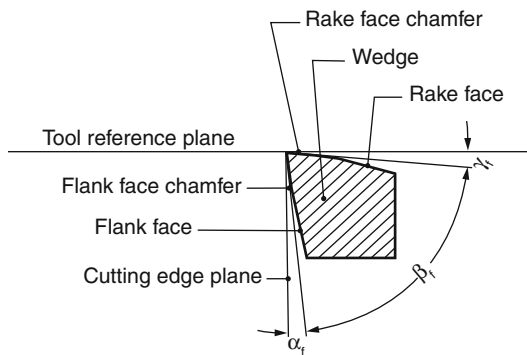


Figure 2.6

wedge, chamfered chamfer angle γ_f ; primary clearance α_f ; chamfer angle β_f

2.4 Angle types and their influence on the cutting procedure

2.4.1 Tool orthogonal clearance α

The normal amount of the tool's orthogonal clearance lies between

$$\alpha = 6 \dots 10^\circ$$

2.4.1.1 A large amount of tool orthogonal clearances

is applied for soft and tough materials, which tend to bond with the cutting edges, and when using tough cemented carbides (e.g. P 40, P 50, M 40, K 40).

A large amount of tool orthogonal clearances:

- a) causes heat build-up in the cutting edge tip
- b) weakens the wedge (danger of cutting edge chipping)
- c) gives under constant wear measure B (width of flank wear B – see Chapter 3.) great displacement of the cutting edge (SKV) (Figure 2.7).
great SKV causes the dimensional deviation on the part (diameter increases) to become too large.

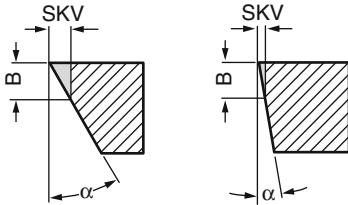


Figure 2.7
Displacement of the cutting edge (SKV) with large and small amounts of tool orthogonal clearance

2.4.1.2 A smaller amount of tool orthogonal clearance

is used with higher-strength steels and abrasion-proof cemented carbides (e.g. P 10, P 20).

A small amount of tool orthogonal clearance:

- a) means that the wedge is reinforced
- b) improves the surface as long as the tool does not press on it. However, if the tool does press on the surface, the tool will heat up, and flank face wear will be substantial.
- c) contributes to damping of vibrations, e.g. chatter vibrations

2.4.1.3 Tool orthogonal clearance at the shank

Since it is necessary to grind the cemented carbide tip with a grinding wheel different from those used for the soft shank of the turning tool, for soldered cutting edges, the tool orthogonal clearance at the shank (see Figure 2.8) should be 2° greater than the tool orthogonal clearance of the cemented carbide insert.

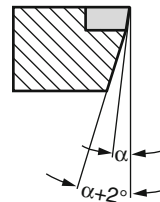


Figure 2.8
Tool orthogonal clearance at the shank of the turning tool is greater than tool orthogonal clearance at the cemented carbide indexed insert

2.4.1.4 Position relative to the workpiece centre

Effective tool orthogonal clearance α_x depends on the tool position relative to the workpiece axis (see Figure 2.9).

k = height displacement in mm

ψ = correction angle in $^\circ$

$$\sin \psi = \frac{x}{d/2} = \frac{2x}{d}$$

If the tool tip is positioned above the workpiece axis (Figure 2.10), then the tool orthogonal clearance is diminished by the correction angle.

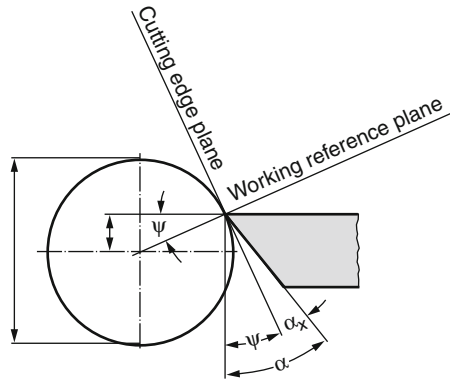


Figure 2.9

Effective tool orthogonal clearance α_x

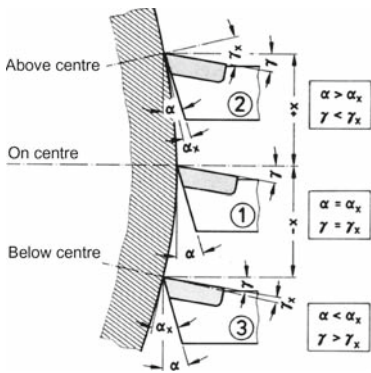


Figure 2.10

Tool angle and working angle for different tool positions

α_x working clearance angle

γ_x working rake angle

ψ correction angle

In cases where the tool tip is situated below the workpiece axis, tool orthogonal clearance is increased by the correction angle.

From this geometry, it can be concluded that:

below centre:	$\alpha_x = \alpha + \psi$
in centre position:	$\alpha_x = \alpha$
above centre:	$\alpha_x = \alpha - \psi$

As the above demonstrates, the effective tool orthogonal clearance corresponds to the measured tool orthogonal clearance only in the centre position. If the tool is

located below the centre, then, due to the alteration of the tool orthogonal clearance and the rake angle, the turning tool is pulled into the workpiece.

2.4.2 Rake angle γ

When turning medium strength steel with cemented carbide tools, the rake angles range from 0 to + 6°, in exceptional cases up to + 18°. For tempering steels and high-strength steels, it is recommended that rake angles from – 6 to 6° be selected.

Whereas the chamfer angle for medium-strength steel is around 0°, in tempering steels, negative chamfer angles are usually used.

2.4.2.1 Large rake angles

are used with soft materials (soft steels, light alloys, copper), which are machined with tough cemented carbides. The greater the rake angle,

- a) the better chip flow
- b) the lower the friction
- c) the smaller the chip compression ratio
- d) the better the workpieces' surface quality
- e) the less the cutting forces.

Large rake angles have also disadvantages. They

- a) weaken the wedge
- b) hinder heat removal
- c) increase the risk of edge chipping.

In short, they diminish tool life.

2.4.2.2 Small rake angles

Small rake angles, down to negative rake angles, are applied for roughing and machining of high-strength materials. For these operations, cemented carbides resistant to abrasion (e.g. P 10; M 10; K 10) are used as the cutting material. Small rake angles:

- a) stabilise the wedge
- b) increase tool life
- c) enable turning at high cutting speeds
- d) save machining time due to c).

When a small rake angle is used, the cross section at the wedge increases, thereby compensating for the lower flexural strength of abrasion-proof cemented carbides.

However, since the cutting forces increase as a function of diminishing rake angle, small rake angles result in

- a) increasing cutting forces

As an estimate, we can postulate that the major cutting force increases by 1 % at an angular reduction of 1°.

- b) an increase in machine input power required

2.4.2.3 Optimum rake angle

In a turning tool with a large positive rake angle and negative chamfer angle (Fig. 2.11), the advantages of positive and negative rake angles can be maximised.

This combination is the optimal solution, because

- a) the positive rake angle provides adequate chip flow and keeps friction on the rake face low;
- b) the wedge's cross-section is enlarged by the negative chamfer angle;
- c) increase of power is diminished (see Figure 2.12).

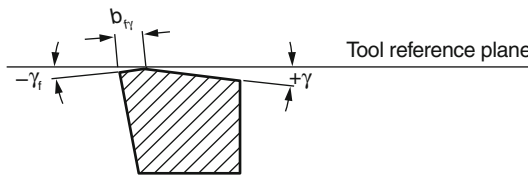


Figure 2.11
Positive rake angle with negative chamfer angle, b_{γ_f} width of chamfer

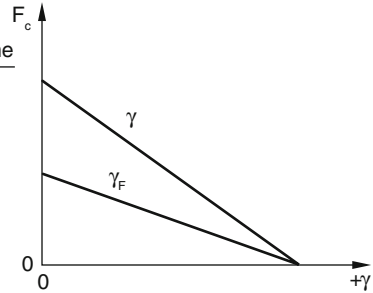


Figure 2.12
Negative chamfer angle means less increase in force than with a negative rake angle without chamfer

2.4.2.4 Position of the tool relative to the workpiece axis

With regard to the rake angle effective during the machining process, in principle, the same equations are valid as for tool orthogonal clearance. Here as well, the tool angle is altered by the correction angle ψ (see Figure 2.10) in the manner shown below.

below centre:	$\gamma_x = \gamma - \psi$
in centre:	$\gamma_x = \gamma$
above centre:	$\gamma_x = \gamma + \psi$

2.4.3 Wedge angle β

is to be kept large for hard and brittle materials and small for soft materials.

2.4.4 Tool cutting edge angles α

The tool cutting edge angle defines the location of the major cutting edge relative to the workpiece (see Figure 2.13). At a given depth of cut a_p , engagement length b of the major cutting edge depends on the tool cutting edge angle (Figure 2.13b).

The smaller the tool cutting edge angle, the greater the engagement length of the major cutting edge. However, the tool cutting edge angle also affects the forces during the cutting process.

The greater the tool cutting edge angle, the greater the feed force and the less the passive force. For this reason, as a rule, instable workpieces demand a large tool cutting edge angle.

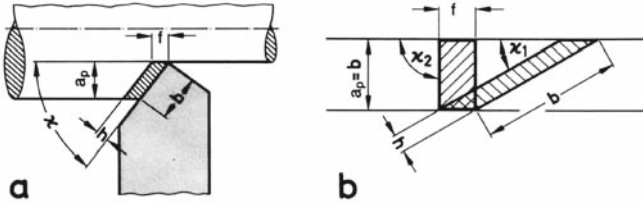


Figure 2.13

Engagement length b is – at given depth of cut a_p – a function of the tool cutting edge angle α . The smaller α (in the figure, $\alpha_1 = 30^\circ$), the greater the engagement length b . Assuming $\alpha = 90^\circ$ (in the figure marked as α_2), then it follows that $a_p = b$

2.4.4.1 Small tool cutting edge angles α (approximately 10°)

result in great passive forces F_p , which tend to deflect the workpiece. Consequently, small tool cutting edge angles are only applied for very stiff workpieces (e.g. calender rolling).

2.4.4.2 Medium tool cutting edge angles (45 to 70°)

are used for stable workpieces. A workpiece is regarded as stable, if

$$l < 6 \cdot d$$

l = workpiece length in mm

d = workpiece diameter in mm

2.4.4.3 Large tool cutting edge angles α (70 to 90°)

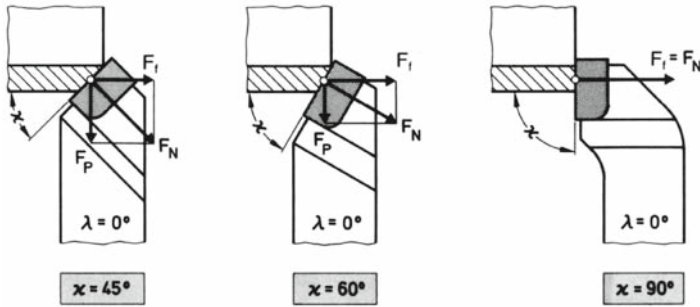
are used for long instable workpieces. These are workpieces for which

$$l > 6 \cdot d$$

If $\alpha = 90^\circ$, the passive force component (Figure 2.14) is zero. As a result, during machining, there appears no force able to deflect the tool.

2.4.5 Tool included angle ε (Figure 2.14)

In most cases, tool included angle is 90° . Only when machining keen corners, ε is less than 90° used.

**Figure 2.14**

Influence of tool cutting edge angle α on feed force F_f and passive force F_p

For copy-turning, use tool included angles from 50 to 58°.

When machining hard materials with rough turning tools, ϵ can be maximally 130°.

2.4.6 Tool cutting edge inclination λ

This parameter describes the slope of the major cutting edge and affects chip flow direction.

2.4.6.1 Negative tool cutting edge inclination

It lessens chip flow, but decreases pressure at the cutting edge tip, since, with a negative tool cutting edge inclination, the cutting edge front rather than the tip penetrates the workpiece first. For this reason, negative tool cutting edge inclination is used with roughing tools and tools for interrupted cut. In these cases, it is common practice to use $\lambda = -3$ to -8° . Planing tools have, due to discontinuous impact with the start of each cut, tool cutting edge inclination up to approx. -10° .

2.4.6.2 Positive tool cutting edge inclination

It improves chip flow. Consequently, it is used for materials that tend to adhere and others that tend toward strain hardening.

2.4.7 Working reference plane

Up to now, angles have been measured against the tool reference plane. Thus, their influence on chip formation and chip flow can be recorded sufficiently in most cases. As Figure 2.15 indicates, at a low circumferential speed-to-feed rate ratio, effective cutting direction angle η increases. Consequently, we must take into account its consequences on rake angle and tool orthogonal clearance. An increase in the effective cutting direction angle η causes the rake angle to increase and tool orthogonal clearance to decrease.

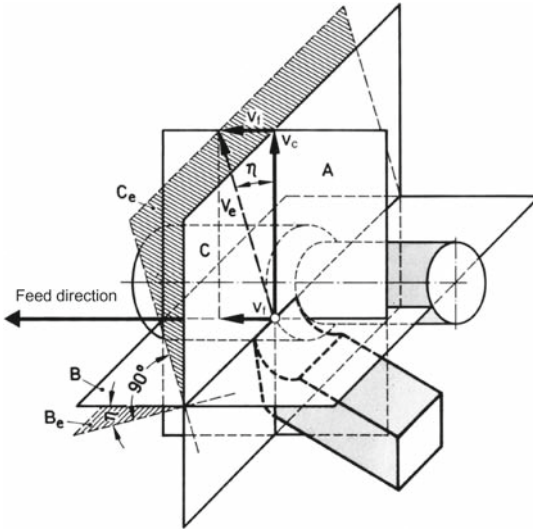


Figure 2.15
Reference planes for the turning tool:
A working plane,
B tool reference plane,
B_c working reference plane,
C tool cutting edge plane,
C_c cutting plane,
v_c cutting speed in primary motion direction,
v_e cutting speed in working plane,
 η effective cutting speed angle,
v_r feed rate in the direction of feed motion

2.5 Cutting parameters

The parameters of the undeformed chip are variables derived from the cutting parameters (depth of cut a_p and feed f) (Figure 2.16).

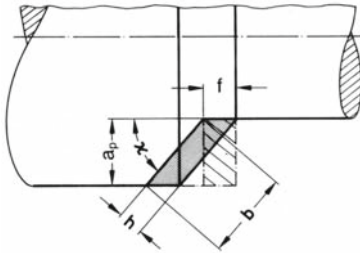


Figure 2.16
Cutting parameters:
 depth of cut a_p , feed per revolution f ,
 width of cut b ,
 thickness of cut h

For cylindrical turning,

2.5.1 Width of cut b

is the width of the chip to be removed, orthogonal to the direction of primary motion, measured in the cut surface.

$$b = \frac{a_p}{\sin k}$$

b in mm width of cut
 a_p in mm depth of cut (infeed)
 k in $^\circ$ tool cutting edge angle

2.5.2 Thickness of cut h

is defined as the thickness of the chip to be removed, normal to the direction of primary motion, measured orthogonal to the cut surface.

$$h = f \cdot \sin \kappa$$

h in mm depth of thickness of cut
 f in mm feed (related to 1 revolution)

2.5.3 Sectional area of chip A

is the sectional area of the chip to be removed, normal to the direction of primary motion.

$$A = a_p \cdot f = b \cdot h$$

A in mm^2 sectional area of chip

2.6 Cutting forces and their origin

2.6.1 Generation of forces

The origin of the cutting forces is to be seen in:

2.6.1.1 resistance to shear, which has to be overcome at material removal.

2.6.1.2 frictional forces occurring between workpiece and tool. They are generated if the chip moves over the rake face, and they occur on the flank face if the tool penetrates the workpiece.

We can represent the forces affecting the wedge in four vectors of force (Figure 2.17a) in a simplified manner.

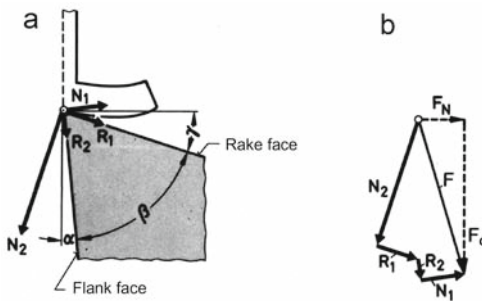


Figure 2.17a + b
 Effective forces on the wedge. N_1 normal force on the rake face; N_2 normal force on the flank face; R_1 frictional force on the rake face; R_2 frictional force on the flank face; F resultant cutting force

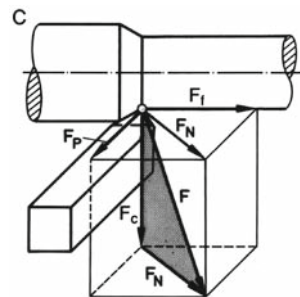


Figure 2.17c
 Decomposition of the resultant cutting force F in major cutting force F_c and minor force F_N and decomposing the minor force F_N into feed force F_f and passive force F_p

Within a polygon of forces, applying each of the four forces, N_1 and N_2 as normal forces and R_1 and R_2 as frictional forces, to the rake face and flank face, provides for the resultant cutting force F .

We decompose the resultant cutting force (Figure 2.17b) into a vertical component, labeled the major cutting force F_c , and a horizontal component, labeled the minor force F_N . This minor force F_N , in turn, can be decomposed into two components (Figure 2.17c), that is, into feed force F_f and passive force F_p .

The most significant forces, the major cutting force F_c and the feed force F_f , are situated in the working plane.

Forces in overview:

F = resultant cutting force

F_c = major cutting force

F_N = minor force

F_f = feed force

F_p = passive force

2.6.2 Specific cutting force k_c and its influencing variables

2.6.2.1 Specific cutting force $k_{c1,1}$

is the cutting force related to:

$A = 1 \text{ mm}^2$ tool material: cemented carbide

$h = 1 \text{ mm}$ rake angle $\gamma = +6^\circ$

$b = 1 \text{ mm}$ tool cutting edge angle $\kappa = 45^\circ$

cutting speed $v_c = 100 \text{ m/min}$

2.6.2.2 Specific cutting force under consideration of its influencing variables

may be calculated with the equation given above:

$$k_c = \frac{(1 \text{ mm})^z}{h^z} \times k_{c1,1} \times K_\gamma \times K_v \times K_{st} \times K_{ver}$$

k_c = specific cutting force in N/mm^2

$k_{c1,1}$ = specific cutting force in N/mm^2 (for $h = 1 \text{ mm}$, $b = 1 \text{ mm}$) (basic cutting force)

h = thickness of cut in mm

z = material constant

K = correction coefficient

K_γ = correction coefficient for rake angle

K_v = correction coefficient for cutting speed

K_{ver} = correction coefficient for wear

K_{st} = correction coefficient for chip compression

Specific cutting values are taken from tables. Table 1 elucidates k_s as a function of material and thickness of cut h .

Table 1.1 Specific cutting forces

Material	$k_{c1,1}$ in N/mm ²	z	Specific cutting force k_{ch} in N/mm ² for h in mm						
			0,1	0,16	0,25	0,4	0,63	1,0	1,6
S 275 JR	1780	0,17	2630	2430	2250	2080	1930	1780	1640
E 295	1990	0,26	3620	3210	2850	2530	2250	1990	1760
E 335	2110	0,17	3120	2880	2670	2470	2280	2110	1950
E 360	2260	0,30	4510	3920	3430	2980	2600	2260	1960
C 15	1820	0,22	3020	2720	2470	2230	2020	1820	1640
C 35	1860	0,20	2950	2680	2450	2230	2040	1860	1690
C 45, Ck 45	2220	0,14	3070	2870	2700	2520	2370	2220	2080
Ck 60	2130	0,18	3220	2960	2730	2510	2320	2130	1960
16 MnCr5	2100	0,26	3820	3380	3010	2660	2370	2100	1860
18 CrNi6	2260	0,30	4510	3920	3430	2980	2600	2260	1960
34 CrMo4	2240	0,21	3630	3290	3000	2720	2470	2240	2030
GJL 200	1020	0,25	1810	1610	1440	1280	1150	1020	910
GJL 250	1160	0,26	2110	1870	1660	1470	1310	1160	1030
GE 260	1780	0,17	2630	2430	2250	2080	1930	1780	1640
White cast iron	2060	0,19	3190	2920	2680	2450	2250	2060	1880
Brass	780	0,18	1180	1090	1000	920	850	780	720

2.6.2.3 Influencing variables

2.6.2.3.1 Material to be removed

The specific amount of cutting force amount depends on the material to be removed. In the case of steel, $k_{c1,1}$ increases as a function of C content and alloying components. The coefficients $k_{c1,1}$ and z are regarded as material constants. They can be derived from function $k_{ch} = f(h)$ in log-log representation (see Figure 2.18):

$k_{c1,1}$ is read at $h = 1$, and z is calculated using the equation below

$$z = \tan a = \frac{\log \frac{k_{ch1}}{k_{ch2}}}{\log \frac{h_2}{h_1}}$$

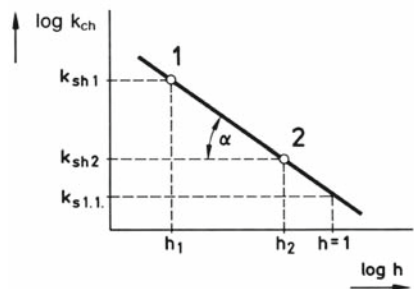


Figure 2.18
Material constant z and specific cutting force

2.6.2.3.2 Thickness of cut h

Thickness of cut is the variable that has the most effect on k_s . The greater h , the less k_s . Since this curve is a hyperbola, the biggest influence of the thickness of cut on the specific cutting force appears in the range of small and medium chip thickness values (see Figure 2.19).

$$k_{\text{ch}} = \frac{(1 \text{ mm})^z}{h^z} \times k_{\text{c},1}$$

- z chip thickness exponent (material constant)
 k_{ch} in N/mm^2 spec. cutting force (influence of h taken into account)
 $k_{\text{c},1}$ in N/mm^2 spec. basic cutting force for $h = 1 \text{ mm}$ and $b = 1 \text{ mm}$

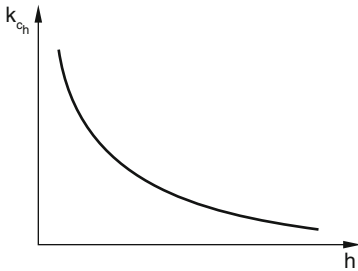


Figure 2.19
Specific cutting force k_{ch} as a function of thickness of cut h

2.6.2.4 Rake angle γ

Rake angle γ is taken into account when calculating the correction coefficient K_γ .

Correction coefficient:
$$K_\gamma = 1 - \frac{\gamma_{\text{tat}} - \gamma_0}{100}$$

γ_0 = base angle = $+6^\circ$ for cutting of steel and $+2^\circ$ for cutting cast iron

γ_{tat} = actual existing rake angle

2.6.2.5 Cutting speed v_c

Cutting speed v has little influence on the cemented carbide region. For this reason, correction may be effectively neglected if $v > 80 \text{ m/min}$.

However, if the influence of v needs to be considered, then calculate correction coefficient for the speed range

$$v_c \text{ in m/min} = 80 - 250 \text{ m/min}$$

as follows:

Correction coefficient:
$$K_v = 1,03 - \frac{3 \times v_c}{10^4} \quad v_c \text{ in m/min}$$

For the high speed steel range $v = 30 - 50 \text{ m/min}$, the coefficient is:

$$K_v = 1,15$$

2.6.2.6 Chip compression ratio

The chip is compressed before shearing. Differing chip compression ratio is considered by K_{st}

External turning		$K_{st} = 1,0$
Internal turning	}	$K_{st} = 1,2$
Drilling		
Milling		
Plunge cutting	}	$K_{st} = 1,3$
Cutting off		
Planing	}	$K_{st} = 1,1$
Shaping		
Broaching		

2.6.2.7 Wear on the cutting edge

Wear at the tool's cutting edge is taken into account by the correction coefficient K_{ver} .

This coefficient relates the rise in the force of a dulling tool to that of the sharp tool.

Correction coefficient: $K_{ver} = 1,3 - 1,5$

2.6.2.8 Depth of cut a_p

In fact, depth of cut a_p does not affect on the specific cutting force (Figure 2.20).

2.6.3 Major cutting force F_c

Major cutting force F_c can be calculated from the cross-section of the chip and the specific cutting force.

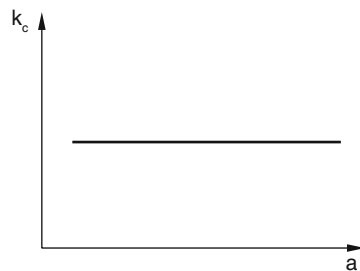


Figure 2.20
Specific cutting force as a function of depth of cut a

$$F_c = A \cdot k_c = a_p \cdot f \cdot k_c = b \cdot h \cdot k_c$$

F_c in N	major cutting force
A in mm ²	cross-section of chip
k_c in N/mm ²	specific cutting force
a_p in mm	depth of cut
f^p in mm	feed (related to one revolution)

2.7 Calculation of power

Here we subdivide the pure cutting power necessary during cutting and machine input power. When calculating the machine input power, one has also to consider the machine's efficiency.

2.7.1 Cutting power P_c

2.7.1.1 Resulting from major cutting force

$$P_c = \frac{F_c \times v_c}{60 \text{ s/min} \times 10^3 \text{ W/kW}}$$

$$v_c = d \times \pi \times n_c$$

p_c in kW	cutting power
F_c in N	major cutting force
v_c in m/min	cutting speed
d in m	workpiece diameter
n_c in min ⁻¹	speed (rpm)

2.7.1.2 Resulting from feed force

Feed power is defined as that portion of the power implemented during cutting, resulting from feed force F_f and feed rate v_f .

$$P_f = \frac{F_f \times v_f}{60 \text{ s/min} \times 10^3 \text{ W/kW}}$$

P_f in kW	feed power
F_f in N	feed force
v_f in m/min	feed rate

We may calculate feed rate v_f by means of the following equation.

$$v_f = \frac{f \times n_c}{10^3 \text{ mm/m}}$$

n_c in min ⁻¹	speed
v_f in m/min	feed rate
f in mm	feed (for 1 revolution)

In comparison with cutting speed v_c , feed rate v_f is very small, as can be seen in the example below:

workpiece \emptyset :

feed f :

cutting speed v_c :

From these data, we find:

$$\text{Speed: } n = \frac{v_c \times 10^3}{d \times \pi} = \frac{100 \text{ m/min} \times 10^3 \text{ mm/m}}{100 \text{ mm} \times \pi} = \underline{\underline{317 \text{ min}^{-1}}}$$

$$\text{Feed rate } v_f: v_f = \frac{f \times n}{10^3} = \frac{0,5 \text{ mm} \times 317}{10^3 \text{ mm/m} \times \text{min}} = \underline{\underline{0,158 \text{ m/min}}}$$

According to Krekeler, the relationship among the forces, assuming a tool cutting edge angle of $\alpha = 45^\circ$, is approximately

$$F_c : F_f : F_p = 5 : 1 : 2$$

In other words, feed force F_f is about $1/5$ of F_c .

Comparing the values F_f and v_f with F_c and v_c , we can determine that the feed power is only the $1/3000^{\text{th}}$ part of the cutting power. Production machines demand quick acceleration to rapid traverse. The power of the auxiliary actuation commonly found in these machines results from mass values and acceleration times.

2.7.1.3 Total cutting power (effective power P_e)

Total cutting power is formed by adding together both partial powers.

$$\boxed{P_e = P_c + P_f}$$

However, since the feed power is very small compared with the cutting power of the major cutting force, feed power is neglected when calculating the machine input power. It follows that:

2.7.2 Machine input power P

$$\boxed{P = \frac{F_c \times v_c}{60 \text{ s/min} \times 10^3 \text{ W/kW} \times \eta_M}}$$

P in kW	machine input power
v_c in m/min	cutting speed
F_c in N	major cutting force
η_M	machine efficiency

3 Tool life T

3.1 Definition

Tool life T is the period of time, expressed in minutes, for which the cutting edge, affected by the cutting procedure, retains its cutting capacity between sharpening operations. The cutting edge remains functional until a certain amount of wear has occurred (3.3).

In drilling and milling, one frequently makes use of the term tool life travel path rather than tool life. Tool life travel path L includes the sum of drilling depths, or the sum of machined lengths in case of milling, which were cut with one tool in the period between sharpening operations. The rate of removal of the metal chips produced by the milling tool between sharpening operations is another way to assess the tool life characteristics of milling tools.

3.2 Characteristics of dulling

3.2.1 Cutting materials for which dulling is mainly caused by temperature

In these tools, the cutting edge becomes unusable as a result of the temperature that occurs on the cut surface. This phenomenon applies to tools made of:

- tool steel and
- high speed steel

With these cutting materials, when tool failure temperature is reached (tool steel 300 °C, high speed steel 600 °C), the cutting edge melts and chips. A cutting edge that is no longer able to cut generates a shiny strip on the workpiece. This phenomenon is called bright braking. The strip emerges if the cutting edge has been melted off and the tool's flank face rubs over the cut surface of the workpiece.

3.2.2 Cutting materials for which dulling is mainly caused by abrasion

Cemented carbide and ceramic fall into this group of cutting materials. For them, there is no characteristic tool failure temperature; instead, wear increases rapidly at the beginning and later continues slowly.

3.2.3 Wear types

3.2.3.1 Flank face wear

For this type, wear at the flank face (Figure 3.1) is measured. The tool is regarded as dull if a certain width of flank wear land B has been achieved. The greater B is, the greater the offset of the cutting edge SKV. The table below (Table 2) shows the permitted widths of flank wear land for some cutting techniques.

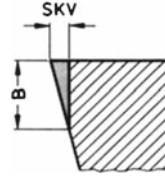


Figure 3.1
Flank face wear with width of flank wear land B

Table 3.1 Dimension of the width of flank wear land [3, p. 182]

Technique	B in mm
Precision turning	0.2
Finish turning	0.3–0.4
Rough turning	
Average sectional areas of chip	0.6–0.8
Large sectional areas of chip	1.0–1.5
Finish planing	0.3–0.4
Rough planing	0.6–0.8
Finish milling	0.3–0.4
Rough milling	0.6–0.8

3.2.3.2 Crater wear

In this kind of wear, the parameters (Figure 3.2) of crater depth K_T , crater width K_B and crater centre distance K_M are measured. The crater coefficient K is determined based on crater depth and crater centre distance. The crater coefficient is a measure of the weakening of the wedge; for this reason, it must not go beyond a certain limit.

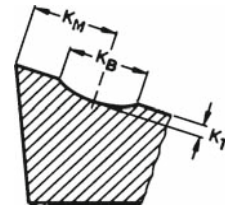


Figure 3.2
Rake face wear with crater depth K_T
and crater centre distance K_M

Depending on the material to be removed and the cutting edge material, the permissible crater coefficients range from 0.1 to 0.3.

$$K = \frac{K_T}{K_M}$$

- K crater coefficient
- K_T in mm crater depth
- K_M in mm crater centre distance

For greater cutting speed values, crater wear dominates. Consequently, this wear criterion should be applied generally in the realm of high cutting speed values

($v > 150$ m/min). In practice, however, width of flank wear land is primarily used as the criterion for determining wear.

Table 3 shows a summary of the most significant wear characteristics:

Table 3 Wear characteristics

Cutting material	Dulling characteristics on the tool	Effects on the workpiece resulting from
Tool steel high speed steel (SS, HSS)	Melting off and chipping of the cutting edge	Bright strips (bright braking) poor surface quality
Cemented carbide ceramic	Abrasion on the flank face and rake face	Dimensional deviation, worsening of the surface quality

In addition to wear characteristics on the tool and workpiece, we may observe that the cutting forces and the machine input power required for cutting increase as a function of wear. For this reason as well, wear on the tools must not exceed the limits specified above.

3.3 Influence on tool life

Tool life T and tool life travel path L of the cutting tools depend on many factors. The most essential ones are explained below.

3.3.1 Workpiece material

The higher the resistance to shear during cutting off, and the greater the strain hardening when the chip is compressed, the greater the forces affecting the cutting edge. Tool life diminishes as a function of rising pressure and pressing- and bending loads.

3.3.2 Cutting material

The cutting materials' wear characteristics mainly depend on their hardness, compressive- and bending strength, temperature resistance, and toughness. Increasing hardness diminishes abrasion. Great compressive- and bending strength, in particular at higher temperatures, improve edge strength. The higher the critical temperature, at which, for example, cutting edges made of high speed steel fail or cutting edges made of cemented carbide chip, the more frictional heat the cutting material is able to resist, and, consequently, the higher the permissible cutting speed. Tough cutting materials withstand bumping or vibrating loads better than brittle ones.

Issues that should be particularly taken into consideration are

- the clear identification of the failure temperature in case of tool steels and high speed steels,

- decrease of toughness, compressive- and bending strength as a function of increasing hardness in cemented carbides.

3.3.3 Cutting edge shape

With a large wedge angle and small rake angle, the stressed cross section of the cutting edge is larger, the forces transmitted increase accordingly, and wear is less than in the case of thin, pointed cutting edges.

3.3.4 Surface

A poor surface, such as one prepared using excessively rough grinding wheels, generates notchy cutting edges that tend to chip. Hard and heterogeneous workpiece surfaces, e.g. with cast- or forged exteriors, cause bumping or vibrating loads on the cutting edge and, when the cutting material is brittle, they diminish tool life.

3.3.5 Stiffness

Unstable workpieces, clamping fixtures, tools and/or components of machine tools reduce the limit of allowable chattering and thus damage brittle cutting materials.

3.3.6 Sectional area of chip

Cutting force and thus the load affecting the cutting edges rises as a function of increasing sectional area of chip. Here, feed affects wear to a greater extent than infeed.

3.3.7 Coolants and lubricants

Depending on their composition, metalworking fluids (coolants and lubricants) have a more or less cooling or lubricating effect. At low cutting speed values, tool life may be improved predominantly by lubrication, at high cutting speed values, predominantly by cooling.

3.3.8 Cutting speed

Cutting speed is the parameter with the strongest influence on tool life T . Tool life curves illustrate the tool life as a function of the cutting speed. It follows from this that tool life strongly decreases as cutting speed increases.

3.4 Calculation and representation of tool life

Tool life can be computed according to the equation below:

$$T = \frac{1}{C^k} \times v^k \quad (\text{Taylor equation})$$

T in min	tool life
C in m/min	cutting speed for $T = 1$ min
k	constant

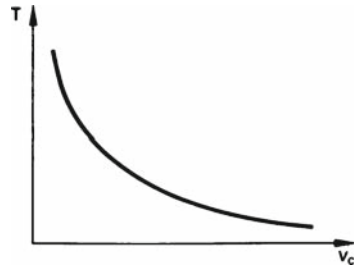


Figure 3.3
Tool life T as a function of cutting speed v_c

As the equation shows, the tool life curve (see Figure 3.3) is an exponential function. From this we learn that tool life strongly decreases as cutting speed increases. If we represent the tool life curve in a log-log network (Figure 3.4), then we obtain a straight line in the practical working range. This straight line is called

T - v curve.

From this T - v curve, we can obtain the corresponding tool life for any cutting speed.

Position and angle of inclination in the tool life curve change as a function of the influencing parameters described.

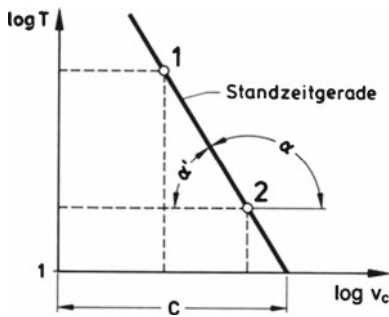


Figure 3.4
Tool life
Logarithmic representation of the function $T = f(v_c)$

Since feed f and depth of cut a_p also affect tool life, to determine the cutting speed v_c , we apply the extended Taylor equation.

$$v_c = C \cdot f^E \cdot a_p^E \cdot T^G \quad \left(G = \frac{1}{K} \right)$$

When C is replaced with v_{c111} , then we obtain

$$v_c = v_{c111} \cdot f^E \cdot a_p^F \cdot T^G$$

v_{c111} in m/min cutting speed for $f = 1 \text{ mm/U}$, $a_p = 1 \text{ mm}$, $T = 1 \text{ min}$
 f in mm feed
 a_p in mm depth of cut
 T in min tool life

In tables of reference provided by the manufacturers of cemented carbide, there are specifications for v_{c111} values and numerical values for the exponents E, F and G for certain groups of materials that may be machined and for various types of cemented carbide.

These values have been added to the tables with ready-to-use reference values – Nos. 7.5 and 7.6 in this textbook.

3.5 Length of tool life and allocation of the cutting speed

In order to place tool life in the production process, tool life for various machines

Production machines with short setup times e.g. numerically controlled machines	$T = 15 \text{ to } 30 \text{ min}$
Machines of average setup time, autonomous machines e.g. turret lathes with cam control	$T = 60 \text{ min}$
Machines with long setup times, machines linked to another one (such as curve-controlled automatic lathes) and chained special-purpose machines (e.g. transfer lines)	$T = 240 \text{ min}$

may be classified (with some limitations) as follows:

$T = 15 \text{ min}$	v_{c15}
$T = 60 \text{ min}$	v_{c60}
$T = 240 \text{ min}$	v_{c240}

The respective cutting speed values assigned are designated as v_{c15} , v_{c60} , v_{c240} , thus, v_{c60} is the cutting speed, at which a tool life of 60 min can be achieved.

The cutting speed values assigned to the permissible tool life values can be taken from tables of reference (see also Chapter 7.8).

3.6 Cost-optimal tool life

The adjustment of optimal tool life values is possible as a result of the development of cutting tool tips that are held in specially designed clamping steel holders and thus are quick to exchange. Consequently, in many cases, the standard tool life values of $T = 60$ min are sacrificed for the benefit of a higher cutting speed and less machine time. Tool life at minimal cost is thus calculated, taking into account tool cost, machine costs per hour, cost of labour, tool positioning time and the material to be cut.

From there, we obtain tool life values $T = 5 - 30$ min with assigned high cutting speed values from 200 to 400 m/min, where cemented carbide is used as the cutting edge material.

4 Tool- and machine curves

4.1 Tool curve

When cutting speed is mapped as a function of the sectional area of chip for a constant tool life in a log-log diagram ($\log v_c = f(\log A)$; for $T = \text{const.}$), the result is a straight line (Figure 25), which is called the

tool curve.

From this straight line, which is based on a specific tool life, we can derive the allowable cutting speed for a defined sectional area of chip (with a fixed ratio of a_p/f). It is also possible to read the allowable sectional area of chip at a predefined cutting speed.

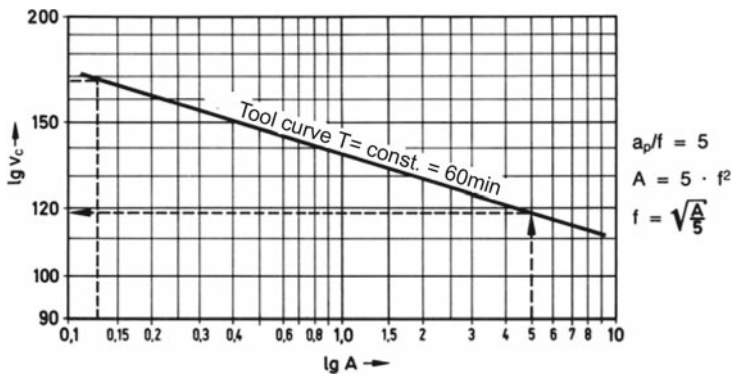


Figure 4.1
Tool curve $\lg v_c = f(\lg A)$ for $T = \text{const.}$

Thus, for example, we can see from Figure 4.1 that for $A = 5 \text{ mm}^2$ the value $v_c = 119 \text{ m/min}$ given a tool life of 60 min. If one correctly assigns the values of v_c and A by means of the machine tool curve, then the tool can be fully utilised in terms of its tool life. If values (v_c, A) are selected whose point of intersection lies below the machine curve, then the tool is not fully utilised in terms of the tool life.

However, if the point of intersection lies above the machine curve, then the tool is overstressed. The allowable wear parameter (compare Chapter 3.3.1.) will thus be exceeded prematurely, and the tool will break down under these circumstances.

Creation of the machine curve

Example:

The task is to generate a machine curve for a tool life of $T = 60 \text{ min.}$

Parameters given:

Cutting edge material: Cemented carbide P20

Material: E 335

Cross sectional ratio: $a_p/f = 5$

Approach:

1. Select the cutting speed values, assigned to two arbitrary feed values, from a table of reference values for v_{c60} or from a tool life curve for $T = 60$ min (compare with Chapter 3.5).

$$\begin{array}{ll} \text{e.g. } f_1 = 0,16 \text{ mm} & v_{c1} = 168 \text{ m/min} \\ f_2 = 1,0 \text{ mm} & v_{c2} = 119 \text{ m/min} \end{array}$$

2. Determine the sectional areas of chip assigned to the cutting speed values

$$\begin{array}{ll} \text{For } a_p/f = 5 & \text{there is } a_p = 5 \cdot f \\ & \text{and it follows that:} \end{array}$$

$$\underline{A = a_p \cdot f = 5 \cdot f \cdot f = 5 \cdot f^2}$$

Then, as a next step:

$$A_1 = 5 \cdot f_1^2 = 5 \cdot 0,16^2 = \underline{0,128 \text{ mm}^2}$$

$$A_2 = 5 \cdot f_2^2 = 5 \cdot 1,0^2 = \underline{5,0 \text{ mm}^2}$$

3. Connect the two points of intersection (v_{c1}/A_1) and (v_{c2}/A_2) with a straight line. This line is the

tool curve for $T = 60$ min

4.2 Machine curve

Within the log-log chart, the machine curve (straight line) shows the functionality between the cutting speed and the sectional area of chip for a

constant machine input power.

Here, the task is to fully utilise the machine's input power. If the sectional area of chip A is matched with the cutting speed resulting from the machine curve, then we always obtain values with which the machine's input power is fully utilised. However, if values (v_c and A) are selected whose point of intersection is below the machine curve, then the input power of the machine will not be utilised. If the point of intersection of v_c and A lies above the machine curve, then the machine will be overstressed, since the required power exceeds the machine input power that is actually available.

Example from Figure 26

In this Figure, the input power $P = 10 \text{ kW} = \text{const.}$

A ratio $a_p/f = 10$ was chosen.

What we are looking for is the allowable cutting speed for a sectional area of chip of $A = 3 \text{ mm}^2$. On the chart, locate $A = 3 \text{ mm}^2$ and move upward to the point

of intersection with the machine curve. Then move to the left (in parallel to the abscissa) and read the allowable cutting speed $v_c = 60$ m/min at the ordinate.

Creation of a machine curve

Parameters given: $P = 10$ kW $\eta_M = 0.7$ (machine efficiency)
 material E 335, $\iota = 90^\circ$, $a_p/f = 10$

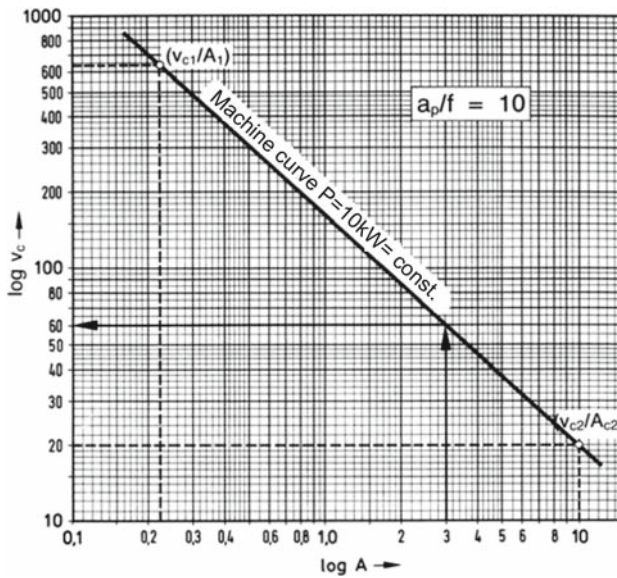


Figure 4.2
 Machine curve
 $\lg v_c = f(\lg A)$ for
 $P = \text{const.}$ and $a_p/f = 10$

Approach:

1. From Table 1: $k_{c1,1} = 2110$ N/mm² $z = 0.17$
2. Choose feed and define thickness of cut

Since $x = 90^\circ$, it follows that:

$$f_1 = h_1 = 0.15 \text{ mm}$$

$$f_2 = h_2 = 1.0 \text{ mm}$$

3. Calculate specific cutting force k_c for the values from 2.

$$k_{ch1} = \frac{k_{c1,1}}{h_1^z} = \frac{2110}{0,15^{0,17}} = \underline{2914 \text{ N/mm}^2}$$

$$k_{ch2} = \frac{k_{c1,1}}{h_2^z} = \frac{2110}{1,0^{0,17}} = \underline{2110 \text{ N/mm}^2}$$

4. Define the machine on which metal cutting should be performed. In this example, input power was assumed with

$$P = 10 \text{ kW.}$$

5. Calculate the sectional areas of chip from the ratio $a_p/f=10$ and the selected feed values ($f_1 = 0.15 \text{ mm}$ and $f_2 = 1.0 \text{ mm}$).

From $a_p/f=10$ it follows that: $a_p = 10 \cdot f$ and $A = 10 \cdot f^2$

$$A_1 = 10 \cdot f_1^2 = 10 \cdot (0.15 \text{ mm})^2 = \underline{0.225 \text{ mm}^2}$$

$$A_2 = 10 \cdot f_2^2 = 10 \cdot (1.0 \text{ mm})^2 = \underline{10.0 \text{ mm}^2}$$

6. Take the power equation and determine the cutting speed values v_{c1} and v_{c2} corresponding to the predefined cutting conditions.

Power equation:
$$P = \frac{a_p \times f \times k_c \times v_c}{60 \text{ s/min} \times 10^3 \text{ W/kW} \times \eta_M}$$

(see Chapter 2.7.2)

$$v_c = \frac{60 \text{ s/min} \times 10 \times 10^3 \text{ W/kW} \times \eta_M}{a_p \times f \times k_c}$$

v_c in m/min	cutting speed
a_p in mm	depth of cut
f in mm	feed per revolution
k_c in N/mm ²	specific cutting force
η_M	machine efficiency

$$A_1 = 0,225 \text{ mm}^2: \quad v_{c1} = \frac{60 \text{ s/min} \times 10^3 \text{ W/kW} \times 0,7}{1,5 \text{ mm} \times 0,15 \text{ mm} \times 2914 \text{ N/mm}^2} = \underline{640 \text{ m/mm}}$$

$$A_2 = 10 \text{ mm}^2: \quad v_{c2} = \frac{60 \text{ s/min} \times 10 \times 10^3 \text{ W/kW} \times 0,7}{10 \text{ mm} \times 1 \text{ mm} \times 2110 \text{ N/mm}^2} = \underline{20 \text{ m/mm}}$$

7. Insert the v_c values found at A_1 and A_2 in the log-log diagram.

$$(v_{c1} = 640/A_1 = 0.225); \quad (v_{c2} = 20/A_2 = 10)$$

8. Connect the points of intersection. The resulting straight line is the desired machine curve.

4.3 Optimum cutting range

The optimal cutting range (for example, for turning) lies at the point of intersection C (Figure 4.3) of the machine- and the tool curves. At this point of intersection, both tool life and machine input power are fully utilised. Since, in practical use,

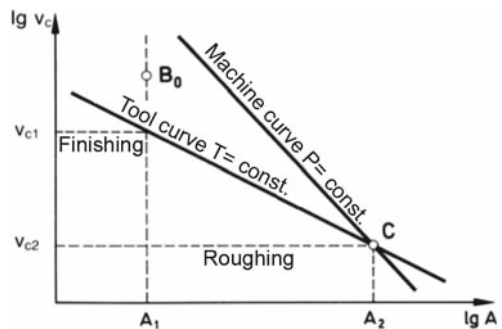


Figure 4.3
Optimum cutting range found based on machine- and tool curves

the sectional area of chip and depth of cut are predefined by the dimensions of the finished part, one seldom succeeds in working under ideal conditions.

The real operating point B_0 always deviates from the point of intersection C .

If the operating point B_0 lies:

4.3.1 above the tool curve, then the tool is overstressed and tool life is reduced.

4.3.2 below the tool curve, then the tool life is not fully utilised.

4.3.3 above the machine curve, then the machine is overloaded.

4.3.4 below the machine curve, then machine input power is not fully utilised.

5 Metal removal rate and chip volume ratio

5.1 Metal removal rate

With regard to the metal removal rate, we have to distinguish between the volume of the removed material Q_w and the space needed for the randomly arranged metal chips Q_{sp} . The volume of the removed material identifies the volume occupied by a chip with cross section $a_p \cdot f$ (depth of cut multiplied with feed) and a defined length per minute.

$$Q_w = a_p \cdot f \cdot v_c \cdot 10^3$$

Q_w	in mm ³ /min	volume of removed material
a_p	in mm	depth of cut
f	in mm	feed
v_c	in m/min	cutting speed
10^3	mm/m	conversion factor for v_c , from m/min to mm/min

The volume of the randomly arranged metal chips removed Q_{sp} is greater than the real volume of the same amount of removed material Q_w , since, in a reservoir, the chips are not located one next to one another without gaps. Chip volume ratio R defines by what factor the volume of the randomly arranged chips Q_{sp} is greater than the volume of the removed material Q_w .

$$Q_{sp} = R \cdot Q_w$$

Q_{sp}	in mm ³ /min	volume of randomly arranged chips
Q_w	in mm ³ /min	volume of removed material
R		chip volume ratio

Consequently, chip volume ratio R results from the ratio:

$$R = \frac{\text{Volume needed for randomly arranged metal chips}}{\text{Material volume of the same amount of metal removal}}$$

The amount of the chip volume ratio R depends on the chip shape.

5.2 Chip shapes

The form of the chips generated during metal cutting depends on:

- type and alloy of the workpiece material,
- the material's phosphor- and sulphur contents
- the cutting conditions (cutting speed, depth of cut, feed, tool cutting-edge angle etc.),
- rake angle and the formation of the chip form level.

The chip shapes are assessed according to two criteria.

5.2.1 Transportability

It is no problem to move short, broken chips, such as fragmented spiral chips, in containers.

By contrast, this is impossible for ribbon chips, since they always demand special treatment (breaking in the chip breaker or briquetting) in order to make them ready for transport.

In a plant with automated manufacturing equipment, where many chips occur, these treatment procedures are very expensive. Consequently, as an alternative, we always aim to produce chip forms that can be handled easily.

5.2.2 Danger for the machine operator

Certain chip forms, such as long ribbon chips and entangled chips whose edges are very sharp, endanger the machine operator.

5.3 Chip volume ratios

Figure 5.1 summarises the most significant chip shapes. Each chip form is assigned to a chip volume ratio R , which defines by what factor the transport volume needed for the specific chip form exceeds the intrinsic material volume of the chip.



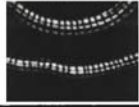



Chip shape		Chip volume ratio R
Ribbon chip		> 100
Entangled chip		> 100
Coil chip		60
Short coil chip		30
Spiral chip		10
Short chip particles		3
$R \leq 3$ Easily usable,		$R = 4-30$ Ok
$R = 31-60$ Usable with limitations,		$R > 100$ Indesirable

Figure 5.1

Chip shapes and chip volume ratios
Chip form representations from [11 and 12]

The appraisal of the chip form involves both criteria (safety of the operator and transportability). According to this approach, ribbon-, entangled- and coil chips are not preferred. The desirable chip forms are short coil chips, spiral chips and pieces of spiral chips.

6 Cutting materials

(For further progress in cutting material development see Appendix)

Cutting tools are subjected to enormous strain. Their cutting characteristics depend on the cutting material selected. Due to the interaction between the material to be removed and the cutting material, the following materials are used depending on type of the metal removal procedure, cutting method, desired tool life, required temperature resistance etc.

6.1 Unalloyed tool steels

Since these steels have low heat resistance, which, in turn, results in low cutting speeds, they are only of minor importance in practice. The most essential data for unalloyed tool steels are given below.

Steel type:	Carbon steel
C content in %:	0.6 – 1.5
Heat resistance in °C:	Up to 300
Operating hardness in HRC:	62 – 66
Allowable cutting speed in m/min:	5 – 10

Table 6.1 Unalloyed tool steels

Denomination		Application
Material number	According to DIN	
1.1540	C 100 W 1	Thread cutting tools
1.1550	C 110 W 1	Twist drills, broaches
1.1560	C 125 W 1	Mills
1.1750	C 75 W 3	Saw-blade bodies for circular saws, collets

6.2 High speed steels

Thanks to alloying elements which form carbide, such as chromium, molybdenum, tungsten, vanadium, these have higher hot hardness, substantially better wear resistance and high retention of hardness. Consequently, high speed steels are much more efficient than tool steels.

It is possible to improve the performance of high speed steels by depositing hard chromium, or by nitriding or carburising. When depositing hard chromium, a thin (0.05 to 0.3 mm) but very hard chromium layer is deposited on the tool using electrolytes. By introducing nitrogen (nitrogenium), it is possible to greatly increase hardness in the marginal zone and to enhance wear resistance.

Carburising is the heat treatment (550 °C) of high speed steels in tanks containing cyanide.

Technical data for high speed steels:

Steel type:	Highly alloyed carbon steel										
C content in %:	0.6 – 1.6										
Most significant alloying elements m%:	<table border="1" style="display: inline-table; border-collapse: collapse;"> <tr> <td>Co</td> <td>Cr</td> <td>Mo</td> <td>V</td> <td>W</td> </tr> <tr> <td>2 – 16</td> <td>4</td> <td>0.7 – 10</td> <td>1.4 – 5</td> <td>1.2 – 19</td> </tr> </table>	Co	Cr	Mo	V	W	2 – 16	4	0.7 – 10	1.4 – 5	1.2 – 19
Co	Cr	Mo	V	W							
2 – 16	4	0.7 – 10	1.4 – 5	1.2 – 19							
Heat resistant in °C:	Up to 600										
Operating hardness in HRC:	62 – 65										
Allowable cutting speed for steel in m/min:	30 – 40										

Table 6.2 Denomination of high speed steels

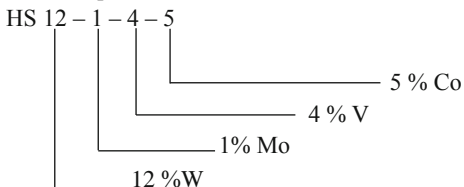
Material - No.	Denomination	Explanation
3202	HS 12-1-4-5	HS = high speed steel The numerals indicate the corresponding percentage of the alloying elements (W, Mo, V, Co). For example HS 12 - 1 - 4 - 5 
3207	HS 10-4-3-10	
3243	HS 6-5-2-5	
3255	HS 18-1-2-5	
3257	HS 18-1-2-15	
3265	HS 18-1-2-10	
3302	HS 12-1-4	
3316	HS 9-1-2	
3318	HS 12-1-2	
3343	HS 6-5-2	
3346	HS 2-9-1	

Table 6.3 High speed steels - ranges of application (data in material numbers without initial number 1.) [10 p.269]

Type of tool	Machining of		
	Light metal	Chilled cast iron, cast iron	Steel
Turning- and planing tools	3302	3202, 3207	3207, 3255, 3265
Cutter bits	3302	3302, 3202, 3207	3202, 3207 3255, 3257
Profile turning tools, gear-shaper cutters	3318	3302, 3343	3207, 3243 3255, 3302
High-quality twist drills with reinforced core	–	3302	3357, 3255
Twist drills (standard)	3318	3318, 3343 3346	3343, 3346
Thread taps	3316	3318, 3357	3318, 3343
Milling cutters, gear cutters	3302, 3318	3302, 3343	3255, 3302 3343
Saw-blade bodies for circular- and hacksaws	3318	3318, 3343	3318, 3343
Reamers	3318, 3302	3302	3318, 3302

6.3 Cemented carbides

Cemented carbides developed out of the so-called stellites (molten alloys of tungsten, chromium and cobalt). The basic substances in carbide-forming materials are oxides of tungsten, titanium and tantalate. A powder mixture of tungsten carbide (WC) or titanium carbide (TiC) and cobalt is first pressed into moldings and then sintered afterwards at 1300 to 1600 °C. In current practice, only sintered cemented carbides (cemented carbides, German abbrev. HM, for short) are used.

Denomination of cemented carbides

Cemented carbides are identified by letters, colours and numbers.

The letters P, M and K specify the materials' major machining groups. They indicate what material or type of material is cut by P, M or K. The letters are also assigned specific identification colours.

- P – blue for long-chip materials
- M – yellow for multi-purpose materials
- K – red for short-chip materials.

Table 6.4 Major machining groups and major application groups for cemented carbides

Range of application (materials)	Cutting techniques, cutting conditions	Name	Typical properties
Long-chip materials for instance steel, cast steel long-chip malleable cast iron	Finishing methods v high, s low, as much as possible without vibrations	P 01	
		P 05	
	Turning, milling v_c high, f medium to low	P 10	
	Turning, milling v_c medium, f medium planing s low	P 20	
		25	
	Turning, planing, milling v_c medium to low, f medium to high	P 30	
	Turning, planing, slotting, milling machining on automata	P 40	
Multi-purpose-, long- and short-chip materials, steel, GS, austenitic manganese steel, alloyed cast iron, austenitic steels, free-machining steels	Turning v_c medium to high, f medium to low	M 10	
	Turning, milling v_c medium, f medium	M 20	
	Turning, planing, milling, v_c medium, f medium to high	M 30	
	Turning, form turning, cutting off – particularly on automata	M 40	
Short-chip materials grey cast iron, chilled cast iron, short-chip steel hardened, non-ferrous metals, plastics	Finishing	K 01	
		K 05	
	Turning, drilling, countersinking, reaming, milling, broaching, scraping	K 10	
	As K 10, stringent requirements in terms of cemented carbide's toughness	K 20	
	Turning, planing, slotting, milling, inadequate cutting conditions	K 30	
	As K 30, high rake angles, inadequate cutting conditions	K 40	

The numbers after the letters are an indicator of the wear characteristics and the toughness of the corresponding cemented carbide. These values constrain the application of individual types of cemented carbide. The higher the number is, the greater the toughness and the lower the wear resistance. The lower the number is, the higher the wear resistance, but the lower the toughness. The parameters are 01, 10, 20, 30, 40, 50.

Accordingly, the cemented carbide P10 is highly wear resistant, but very brittle. Consequently, it should never be used for planing, in which the cutting edge is subjected to sudden stress at each beginning of the cut. Under these circumstances, tool life would be shortened not by wear, but by early chipping of the cutting edge. However, this cemented carbide would be suitable to machine high-strength steels at high cutting speeds.

The parameters of cemented carbides

composition in %:	WC	TiC + TaC	Co
	30 – 92	1 – 60	5 – 17
Heat resistance in °C:	1000		
Operating hardness in HV 30:	1300 – 1800		
Allowable cutting speeds for steel in m/min:	on average 80 – 300		

Table 6.4 on page 36 outlines the denomination and the ranges of application for cemented carbide tools.

6.4 Ceramics

The main component of ceramic materials is aluminum oxide (Al_2O_3). We distinguish between two groups of sintered oxides: The pure aluminum oxides (Al_2O_3) with low alloyed contents of other metal oxides and those sintered oxides that contain not only Al_2O_3 , but also greater amounts (40 to 60%) of metal carbides.

Ceramic tools are very hard and wear resistant. However, they are very brittle and sensitive to fracture.

Due to their great wear resistance, ceramic tools can withstand extremely high cutting speeds. Consequently, they are preferred to generate workpieces of high surface qualities in finishing and fine finishing.

However, their low toughness limits their range of applications. Ceramic tools are consequently used for turning, machining short-chip materials, such as grey cast iron, and cutting higher strength steels ($\sigma_B > 600 \text{ N/mm}^2$).

The parameters of ceramic

Composition in %:	Al_2O_3	Mo_2C	WC
	97	–	–
	40	–	60
	60	40	–

Heat resistance in °C:	1800 (but very sensitive to thermal stress)
Operating hardness (hardness according to Vickers in kN/mm ²):	12 – 20 (30)
Allowable cutting speeds for steel and grey cast iron in m/min	100 – 300 roughing 200 – 1000 finishing

6.5 Diamond tools

The hardest and densest of all materials known, diamond consists of pure carbon. Due to its great hardness, diamond is very brittle and thus very sensitive to impact and heat. These characteristics make it suitable for use in diamond tools. These are predominantly used for finishing- and superfinishing tools. With diamonds, surface roughness values to 0.1 mm can be achieved. Diamonds allow cutting speeds up to 3000 m/min, while the standard range of operation is from 100 to 500 m/min.

Diamonds are used primarily to machine the following carbon-free materials following:

Light metals:	aluminum and aluminum alloys
Heavy metals:	copper- and copper alloys, cathode copper, brass, bronze, argentan
Precious metals:	platinum, gold, silver
Plastics:	
Duroplastics:	glass fibre reinforced plastics, laminated paper, bakelites etc.
Thermoplastics:	plexiglass, vulcanised fibre, teflon etc.
Natural materials:	hard rubber, soft rubber.

Diamond tools have cutting edges with defined geometry.

The most significant cutting edge forms of compact diamonds are shown in Figure 6.2. The bevelling cutting edge is the cutting edge that is most frequently in use.

In addition to compact industrial diamonds clamped in specific holders, as shown in Figure 6.1, so-called polycrystalline cutting bodies have also recently begun to be used. For polycrystalline cutting bodies, many very small diamonds are crystallized under high pressure and at high temperatures in the cutting edge area of a cemented carbide tool body. The cutting tips manufactured in this way can be soldered on or clamped.

Some polycrystalline cutting tips used for cutting outer geometries are illustrated in Figure 6.3. The cutting tips can have the following angular values

Tool orthogonal clearance:	0°; + 6°; + 12°
Rake angle:	- 6°; 0°; + 6°

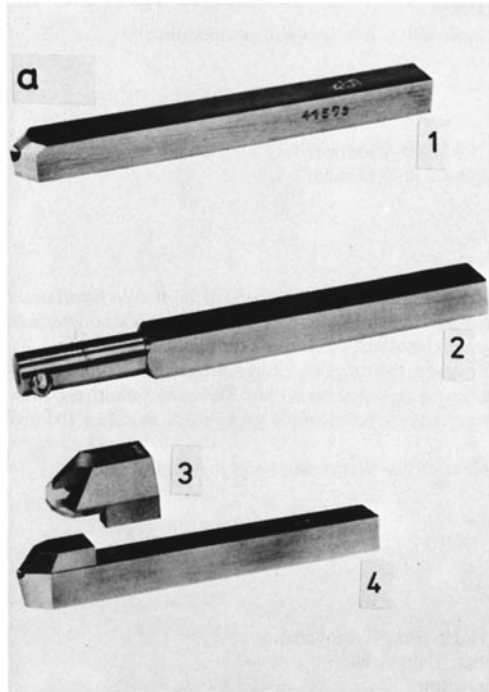
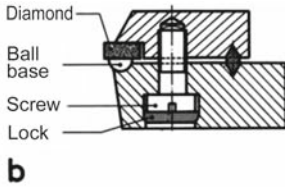


Figure 6.1a

Holders for diamond turning tools

- 1 for low tip heights,
- 2 holder for diamond drills,
- 3 sighting device by Winter, to align the bevelling cutting edges
- 4 holder with reinforced head
(photo by Winter & Sohn, Hamburg)

Figure 6.1b

Holder with ball-based fit (according to Winter & Sohn)

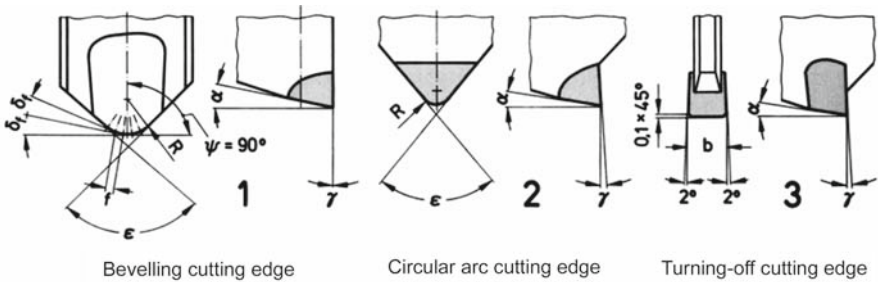


Figure 6.2

The most essential cutting edge forms of diamond turning tools

- 1 bevelling cutting edge, 2 circular arc cutting edge, 3 turning-off cutting edge
(photo by E. Winter & Sohn, Hamburg)

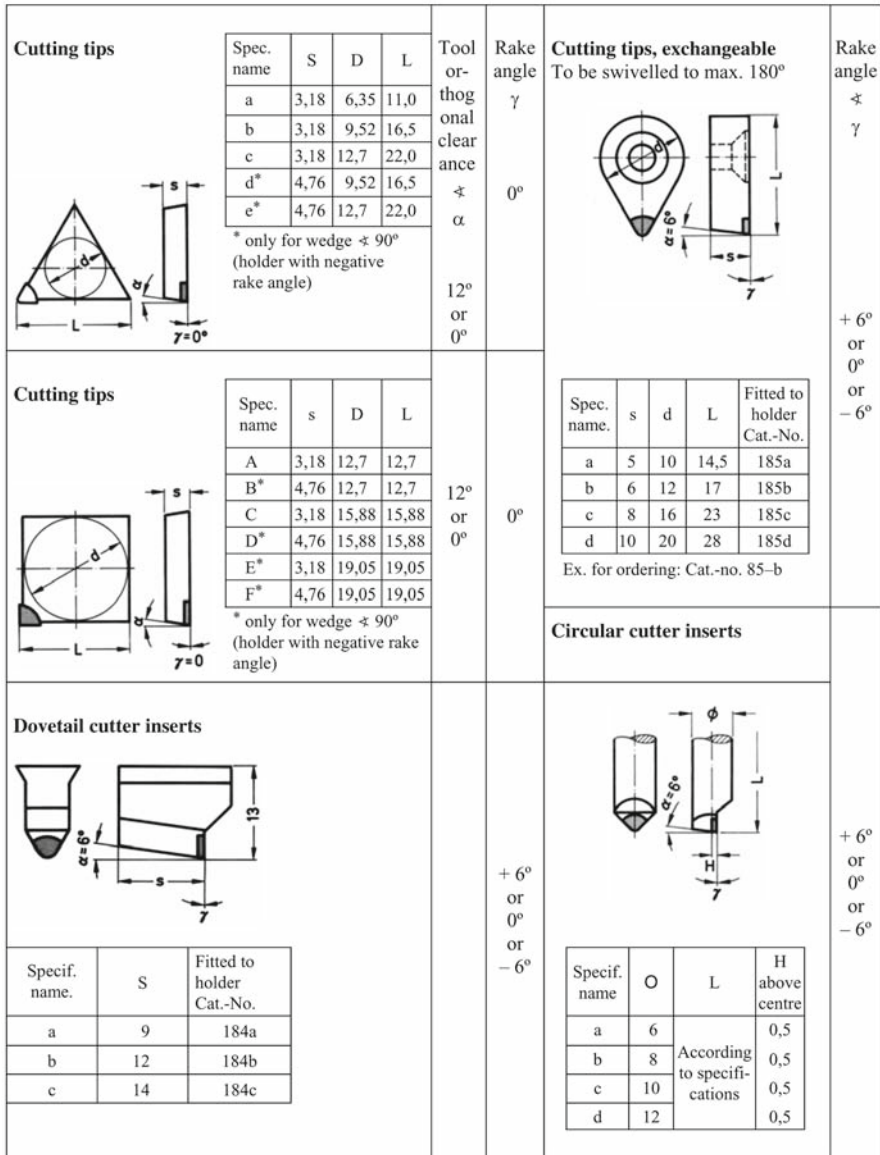


Figure 6.3
Diamond cutting tips and associated angles (photo by E. Winter & Sohn, Hamburg)

7 Turning

7.1 Definition

Turning is defined as a metal cutting technology in which the cutting movement is carried out by the workpiece, whereas the tool performs the auxiliary motion (feed and infeed). Feed and infeed are done using longitudinal- and cross slides in most lathes (Figure 7.1). When turning very thin parts, the workpiece is supported at the point of processing, and feed motion is carried out by the headstock.

The tool used for turning, the turning tool, has *one* major or primary cutting edge.

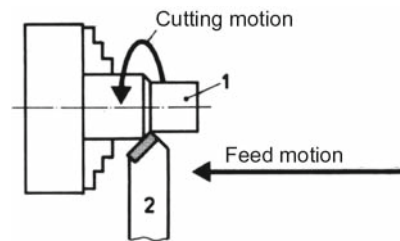


Figure 7.1
Cutting- and feed motion during turning
1 workpiece, 2 tool

7.2 Turning technology

Simple turning parts are shaped by a feed motion in the turning axis direction or normal to it. The associated methods are named according to the direction of the feed motion during machining. The contour of the finished part is usually created in a number of cuts. Infeed is performed outside the workpiece before each cut.

7.2.1 Cylindrical turning

In cylindrical turning, the turning tool moves in parallel to the workpiece axis, as a rule, from the right to the left (Figure 7.1).

This method is applied to cut a cylindrical workpiece to a certain diameter.

7.2.2 Facing

During facing (Figure 7.2), the tool moves normally to the workpiece axis. It is used to machine an end surface or a shoulder. The motional direction of the turning tool depends on the type of machining, the cutting edge form and the tool position, as well as on the workpiece geometry (hollow part, solid). In roughing, a motion from the outside to the inside is preferred, whereas in finishing the reverse is true.

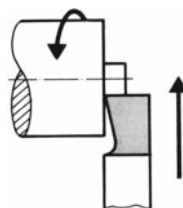


Figure 7.2
Feed direction of the tool at facing

7.2.3 Parting

In parting, the tool moves normally or in parallel to the workpiece axis. The contour is mostly generated by parting a single time down to manufacturing depth.

7.2.3.1 Recessing

Recessing is used to manufacture a groove of a specific form, e.g. grooves for ends of threads.

If the groove form, such as in Figure 7.3, is straight-lined and in parallel to the workpiece axis, then, in recessing, the whole width of the major cutting edge of the parting tool is engaged. The tool included angle is here 90° .

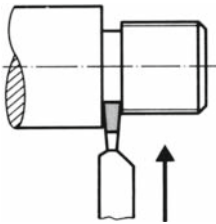


Figure 7.3
Recessing of a groove

7.2.3.2 Cutting off

Cutting off a finished workpiece from the rod is done using cutting off technology. In contrast to recessing (Figure 7.3), in cutting off, the major cutting edge is inclined toward the workpiece axis (Figure 7.4). The tool-included angle of the parting tool is less than 90° . As a result, two different end diameters (d_1 , d_2) are created. Consequently, in the final stage of cutting off, the part that is hanging on at the smaller pivot diameter breaks off without residual end.

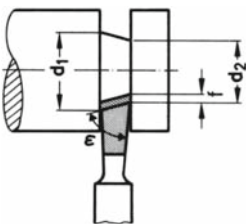


Figure 7.4
Location of the major cutting edge of the parting tools at cutting off $\varepsilon < 90^\circ$

7.2.3.3 Biting

Biting is an end-cutting procedure, in which the feed direction of the end-cutting tool is situated in parallel to the workpiece axis. This method is used, for example, to cut a large disk out of a plate, or to manufacture grooves on end faces (Figure 7.5).

If tapered workpieces or workpieces with sculptured boundaries need to be manufactured, three methods can be used: form turning, turning with inclined upper slide (taper turning), turning with simultaneous and controlled movement of longitudinal- and cross slides (copy turning, NC turning).

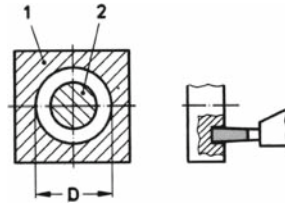
Figure 7.5

Biting of a large hole

1 workpiece,

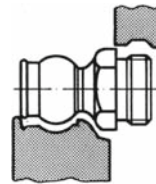
2 swarf resulting from biting

D hole diameter in the workpiece



7.2.4 Form turning

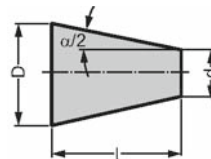
In form turning, the major cutting edge of the turning tool incorporates the contour that is to be generated on the workpiece. As a rule, the form is produced in the workpiece using recessing technology. Workpieces produced this way (Figure 7.6) are also called form turned pieces, and the tools are called form turning tool.

**Figure 7.6**

Form turned piece produced with the form turning tool using parting technology

7.2.5 Taper turning

Taper turning is a cylindrical turning procedure in which the diameter to be generated is constantly changing. This method is used to produce conical shafts. Taper angle α can be calculated according to the equation below (Figure 7.7).

**Figure 7.7**

Taper parameters

$$\operatorname{tg} \frac{\alpha}{2} = \frac{D-d}{2 \cdot l}$$

$\alpha/2$	in $^{\circ}$	half taper angle
D	in mm	large taper diameter
d	in mm	small taper diameter
l	in mm	taper length.

There are two ways to generate conical shafts.

a) by bringing the upper slide into an inclined position

When doing this, rough adjustment of the upper slide is carried out by means of the degree scale, and fine adjustment is performed with a gauging taper which is scanned with a dial gauge. This method is used to produce short tapers (Figure 7.8).

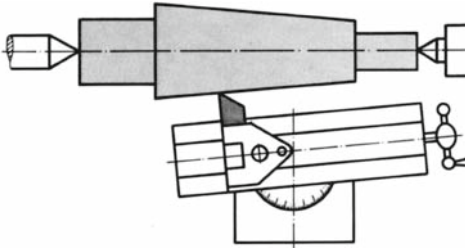


Figure 7.8
Taper turning by swivelling out the upper slide

b) by shifting the tailstock sidewise

Because the tailstock can only be moved sidewise on its guidance base to a small degree, it is only possible to generate slim tapers with the tailstock slide (Figure 7.9). The required tailstock shift can be calculated according to the equation below:

$$s_R = \frac{D - d}{2}$$

s_R	in mm	Tailstock shift
D	in mm	Large taper diameter
d	in mm	Small taper diameter

The limit of the tapers generated this way is $s_R/l = 1/50$. For greater sidewise shifts, the workpiece tends to run off, since the on-centre adjustment (Figure 40) is no longer adjacent to the tailstock centre.

For this reason, ball grains are used instead of centre points in the case of larger workpieces.

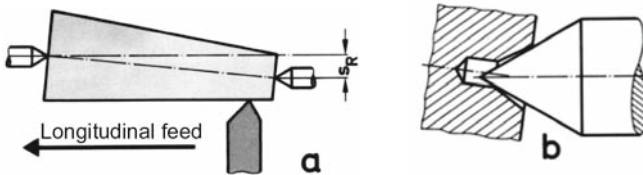


Figure 7.9
Taper turning by sidewise shifting of the tailstock
a sliding movement of the tailstock s_R , *b* inadequate position of the tail centre

Tapers that are produced by swivelling out of the tailstock, can also be generated with automatic lengthwise feeding movement of the lathe.

7.2.6 Copy turning

The shape of the workpiece is taken from geometry storage (taper guide bar, template, and replica) and transmitted to the longitudinal- and cross slides.

7.2.6.1 Copy turning with the taper guide bar

The taper guide bar is an additional attachment fixed at the rear side of the lathe's bed (Figure 7.10).

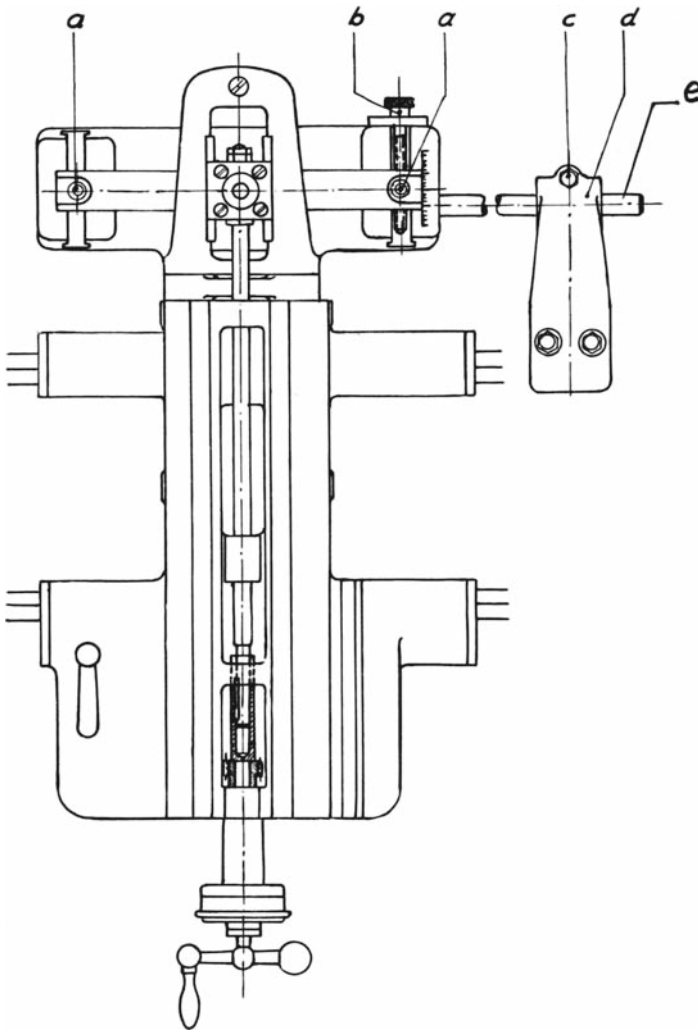


Figure 7.10

Taper turning attachment (taper guide bar)

a fixing screw, *b* adjusting screw, *c* binder screw, *d* pedestal, *e* guide rod

photo courtesy of Neue Magdeburger Werkzeugmaschinenfabrik, Sinsheim/Els.

It is possible to swivel out the guide bar sidewise and to bring it into the desired taper angle. The cross slide is immediately connected with the taper guide bar, and is shifted radially during the longitudinal turning motion, according to the guide bar's angle of inclination. The adjustment screw to adjust the cross slide is dismounted when working with taper guide bar.

The automatic lengthwise feeding movement of the lathe is used even in this method as well. With the taper guide bar, it is possible to manufacture tapers up to a ratio of 1 : 5 (taper angle about 10°) and 500 mm length.

7.2.6.2 Copy turning with template

In copy turning, the cross slide or a special copying slide is correspondingly moved forcibly in cross direction, according to the corresponding longitudinal position.

In the case of the hydraulic copying attachment (Figure 7.11) shown in our example, a probe samples a copying template that incorporates the shape to be manufactured, and with this input it controls a hydraulic piston, which, in turn, is connected to the cross slide via a valve. There, velocity in longitudinal direction remains constant (constant lead) and is generated, as during normal cylindrical turning, by the lathe's feed rod and leadscrew. In other design variants, such as with piston and cylinder in longitudinal direction, it is possible to change the lead according to the workpiece contour.

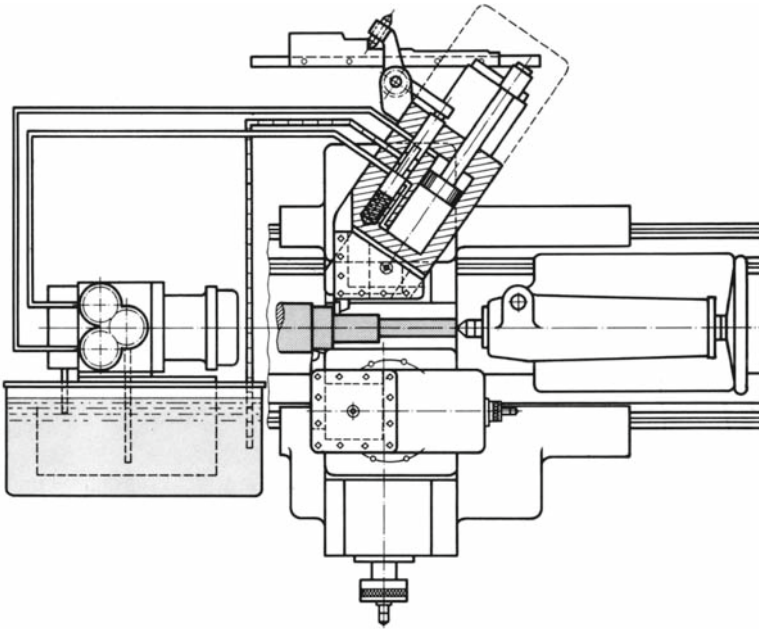


Figure 7.11

Diagram showing a hydraulic copying attachment [from 35]

7.2.7 Turning with numerical control (NC, CNC)

Instead of the analogous representation of the nominal workpiece geometry through the template, it is also possible to define the shape by its characteristic dimensions. In the case of numerically controlled machines, for example, this definition is taken from the CAD data (Computer Aided Design) of the design drawing, transformed into CNC programs, and is afterwards implemented in the signals for the controllable drives (longitudinal and cross slide) (Figure 7.12). Numerically controlled lathes are capable of generating the contours of any turning part imaginable and mathematically definable, insofar as the cutting edge shape of the tool will allow a cut. A schematic illustration of the structure of such a machine is found in Figure 7.12.

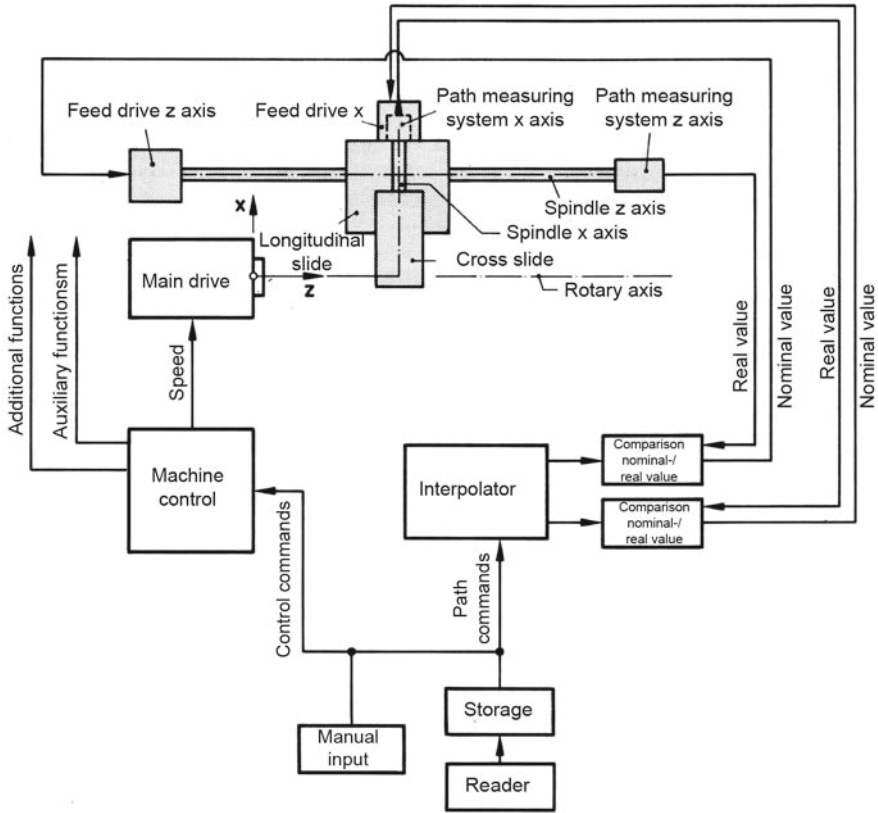


Figure 7.12
Structure of a numerical control for 2- axis turning [according to Dräger]

7.2.8 Thread turning

Thread turning is a type of cylindrical turning in which the feed corresponds to the thread pitch of the thread to be generated. At the lathe, the exact feed required for thread cutting is created by the lead screw and the feed gear mechanism.

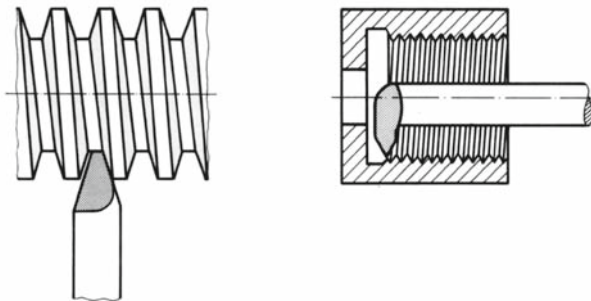


Figure 7.13
Workpiece, on which the turning tool is allocated for thread turning
a external thread, *b* internal thread

In turret lathes, the feed for thread cutting is produced using a guide carriage (replacement lead screw). The thread turning tool is the single-point threading tool (Figure 7.13).

In the numerically controlled lathe, the feed is adjusted through an electrical connection between the main spindle and the feed driving motor.

7.2.9 Application of turning methods

The ranges of application are summarised in Table 7.1.

Table 7.1 Summary of turning methods

Technique	Application	
	To manufacture or produce:	Figure
Turning	Any rotary parts	32
Cylindrical t.	Cylindrical shafts	32
Facing	End faces and shoulders	33
Recessing	Grooves	34
Cutting off	Parting off of finished parts	35
Biting	Large holes	36
Form turning	Form turned pieces of short length	37
Taper turning	Tapered shafts	38–40
Copy turning	Form turned pieces with typical longitudinal contour, for example, shape shafts	41–42
NC turning	Moldings, such as chuck- and shaft parts, with complicated contour	43
Thread turning	External- and internal threads	44

7.3 Achievable accuracy values using turning

7.3.1 Dimensional accuracy values

The dimensional accuracy values that can be achieved with finish turning range from IT 7 to IT 8

With fine finishing, given optimal turning conditions, accuracy values of IT 6 are feasible.

The tolerances assigned to the ISO series of tolerances may be taken from Tables 19.3 to 20.1 (Appendix).

7.3.2 Surface roughness

It is possible to calculate the surface roughness or peak-to-valley height (so-called shape roughness, Figure 7.14) that occurs in theory in turning. It depends above all on the value of the peak radius r of the turning tool and on feed f .

Shape roughness can be forecast according to the following equation:

$$R_{\max} = \frac{f^2}{8 \times r}$$

R_{max}	in mm	max. surface roughness
f	in mm	feed per revolution
r	in mm	peak radius of the turning tool

Since surface roughness is mostly predefined by the machining identifier, one has to know the feed for which travel must take place at given peak radius r . For this reason, the equation above can be adjusted according to feed.

$$f = \sqrt{8 \times r \times R_{max}}$$

Today, it is common practice to work with R_z in reference values (as it is in Table 7.2). R_z is the mean value, based on single surface roughness values of 5 successive measuring values.

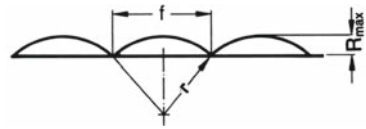


Figure 7.14
Diagram of a turned surface
 f feed, r peak radius, R_{max} max. surface roughness

To avoid having to calculate these values, as a simplification, for some shape roughness values of Table 7.2, we can simplify matters by reading the required feed values at given peak radius r .

The feed values in Table 7.2 are calculation values resulting from the equation above. However, since a lathe only has some distinct feed values, if it is impossible to adjust it to the calculated value, we must approximate that value by using the closest value below it.

Table 7.2 Feed f in mm as a function of the required averaged roughness R_z and peak radius r

Peak radius r (mm)	Feed f (mm/U) = $f(R_z, r)$					
	Fine turning		Finishing		Roughing	
	R_z 4 μm	R_z 6,3 μm	R_z 16 μm	R_z 25 μm	R_z 63 μm	R_z 100 μm
0,5	0,13	0,16	0,26	0,32	0,50	0,63
1,0	0,18	0,22	0,36	0,45	0,71	0,89
1,5	0,22	0,27	0,44	0,55	0,87	1,10
2,0	0,25	0,31	0,50	0,63	1,00	1,26
3,0	0,31	0,38	0,62	0,77	1,22	1,55

The actual surface roughness, and thus peak-to-valley height R_{max} according to DIN 4766 and ISO 1302, deviates from the theoretical shape roughness. Smooth running of the machine during cutting and the selected cutting parameters have a significant impact on roughness. In addition, we have to note that it is frequently not enough to specify the peak-to-valley height; rather, data, for example, for the average peak-to-valley height or the percentage contact area are required.

7.4 Chucking devices

7.4.1 to chuck the workpieces

The chucking elements of most practical use for turning are:

7.4.1.1 Faceplates (Figure 7.15)

These are used to clamp large-sized flat parts and parts with a non-rotary shape. Each jaw can be independently readjusted in the faceplate.

7.4.1.2 Self-centering chucks

Self-centering chucks have 3 jaws that clamp the workpiece and centre it automatically during clamping. Chucks with 2 or 4 jaws are also available.

In the case of the self-centering chucks, all 3 jaws are adjusted simultaneously by

- a) a spiral (spiral chuck) (Figure 7.16)
- b) spiral ring chucks, in which the chuck has adjustable jaws (Figure 7.17)
- c) wedge rods (wedge rod chuck, Figure 7.18)

by means of a socket wrench.

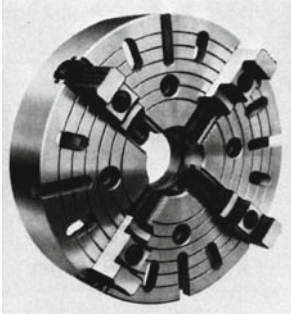


Figure 7.15
Faceplate with 4 independently adjustable jaws
(photo by Röhm, Sontheim)

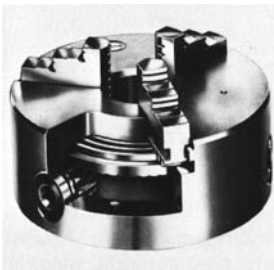
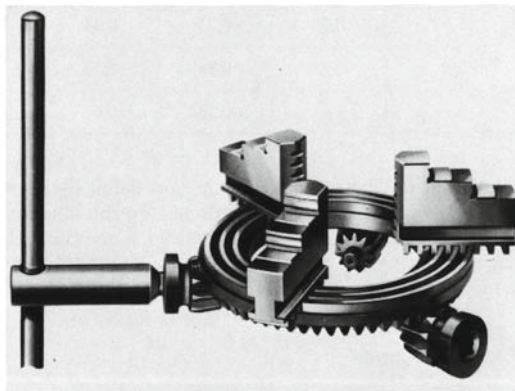


Figure 7.16
Spiral chuck
(photo by Röhm, Sontheim)



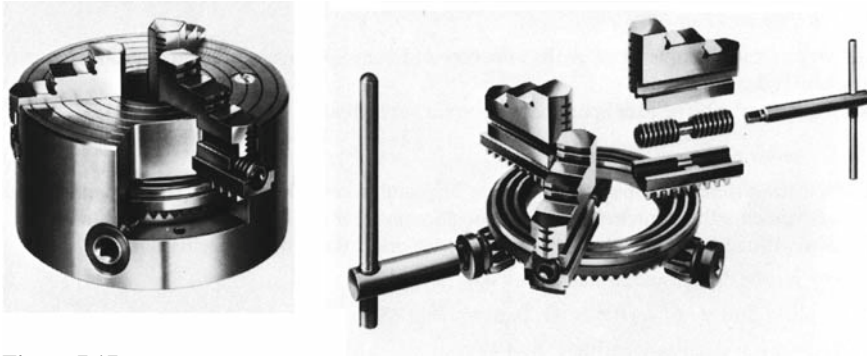


Figure 7.17
Spiral ring chuck with adjustable jaws
(photo by Röhm, Sontheim)

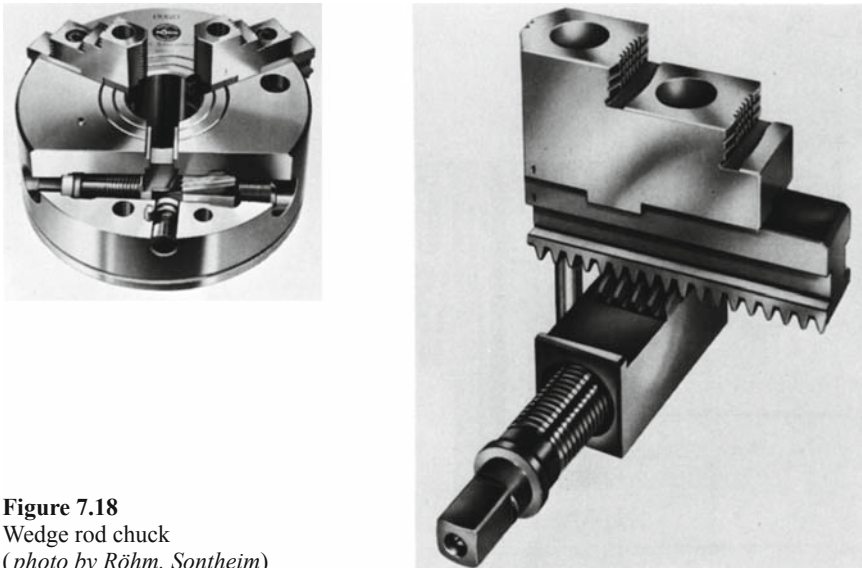


Figure 7.18
Wedge rod chuck
(photo by Röhm, Sontheim)

The spiral chuck according to DIN 6350 uses an Archimedean spiral as the adjusting element. In this spiral the jaws, which are also ground, grip with hardened and ground thread flanks. At the bottom side, this spiral ring is designed as a ring gear. Pinions that are situated at 3 positions along the circumference of the chuck, engage into this ring gear. With the square wrench, we can twist each pinion and, given this connection, the spiral ring. Thus, the radial chucking motion of the jaws is generated.

In the wedge chuck, a tangentially located screw shifts a wedge bar, which, in turn, rotates a driving ring. Turning the driving ring simultaneously shifts the two other wedge rods, with which the master jaws of the chuck engage.

In its basic structure, the spiral ring chuck with adjustable jaws corresponds to the spiral chuck. Here, however, the intrinsic jaws, which can be adjusted using a spindle, are put on a master jaw. The master jaws are moved by the spiral ring – as in the spiral chuck.

7.4.1.3 Power-operated chucks

In power-operated chucks, the clamping force is generated pneumatically, hydraulically or electrically.

In the power-operated wedge rod chuck illustrated in Figure 7.19, the force is generated by a circulating pneumatic cylinder. This cylinder actuates the chuck's axial piston on a draw rod, 3 inclined surfaces of which are engaged with the inclined surfaces of the wedge rods.

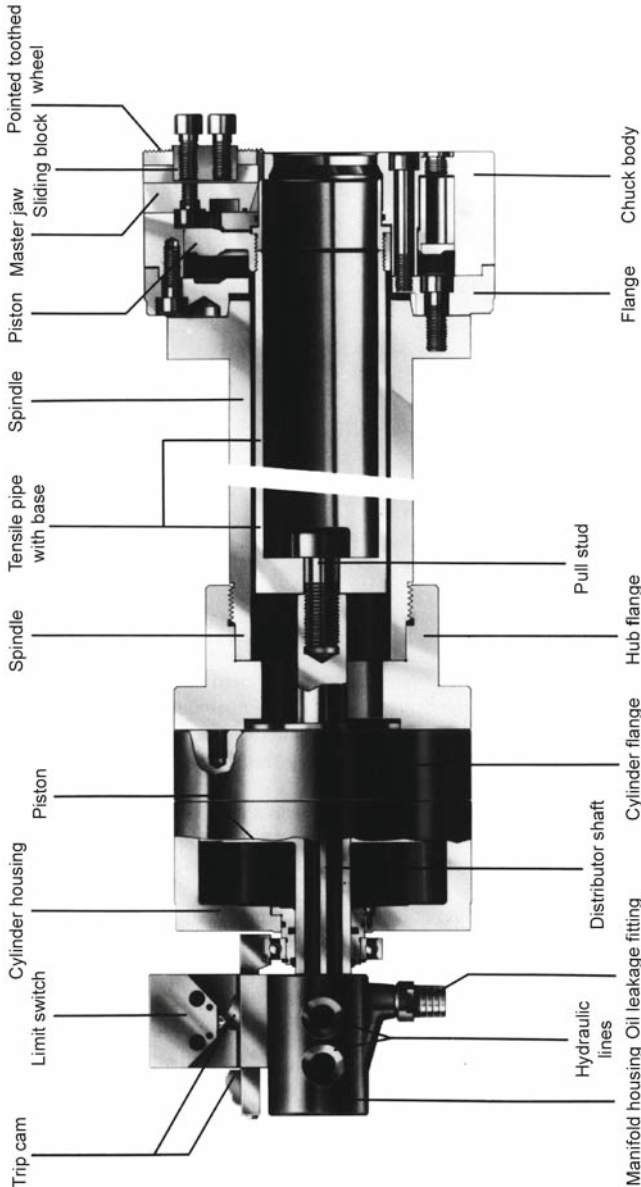


Figure 7.19 Partially hollow chuck: power-actuated chuck with opening, hydraulic full chuck cylinder without opening. (photo by Röhler, Sontheim)

7.4.1.4 Collets

On semi- or fully automatic machines, such as turret lathes and automatic lathes, most workpieces are cut from the rod. Here, collets are used as clamping devices.

We distinguish between force- and form-locked collets. In the case of the force-locked collets according to DIN 6341 (Figure 7.20), the collet taper is drawn into the countertaper of the spindle head. At this time, the elastic clamping segments of the clamping taper press onto the rod that is to be clamped and retain it.

However, since the rod material differs in diameter as a result of the existing diameter tolerance, the collet is drawn into the clamping taper depending on tolerance. Consequently, the zero position of the collet is changed. This may also result in longitudinal deviations of the workpiece.

In the case of positive collets according to DIN 6343, the intrinsic collet is axially fixed. Clamping is generated by a pusher beam, whose inner taper shifts along the collet's outer taper (Figure 7.21).

Since, in the force-locked collet, the clamping force is generated by pulling into the countertaper, it is also called a chuck draw rod. Analogously, the positive collets are also called pusher beams.

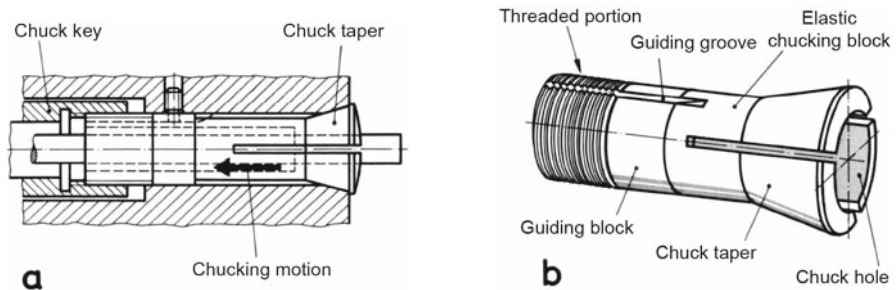


Figure 7.20 a + b
a force-locked collet, *b* exchangeable collet

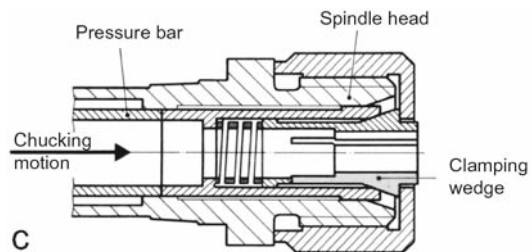


Figure 7.20c
 Positive collet

The collet's clamping range covers only a few tenths of a millimetre (on average 0.2 mm). For this reason, for different rods one needs special diameter-related collets whose diameters correspond to the rod diameter.

7.4.1.5 Arbours

The arbour (Figure 7.21) is needed to mount workpieces with a hole. The so-called expansion arbour is a slotted sleeve with inner taper. A clamping nut is drawn into this sleeve by means of a clamp nut. This way, the slotted arbour expands itself around the outer diameter and thus clamps the workpiece.



Figure 7.21
Sleeve arbour
MZE (photo by
Röhm, Sontheim)

The clamping region of the Stieber slide bushing peak arbour GDS shown in Figure 7.21 is 1.2 mm over a clamping range from 15 to 51 mm \varnothing , and 2.4 mm over a clamping range from 52 to 90 mm \varnothing . The maximal concentricity error of these slide bushing tools is less than 0.01 mm.

7.4.1.6 End face drivers

are required to carry shafts that are to be turned between centres (Figure 7.22).

The centre, which is centred inside the shaft, can be stationary or rotating. Lathe carriers (rotating grippers) are used to mount pipes (Figure 7.23).

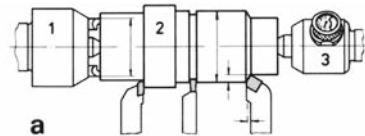


Figure 7.22

End face driver

(photo by Neidlein, Stuttgart) a end face driver, 2 workpiece, 3 rotating centre (photo by Röhm, Sontheim)

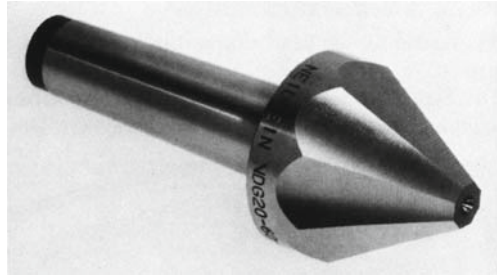


Figure 7.23
 Lathe carrier (rotating gripper) to carry pipes (photo by Neidlein, Stuttgart)

7.4.1.7 Innovative clamping system “SPANNTOP nova”

The clamping device “SPANNTOP nova”, shown in Figure 7.24, is an innovative clamping system, which can be used universally on any lathe

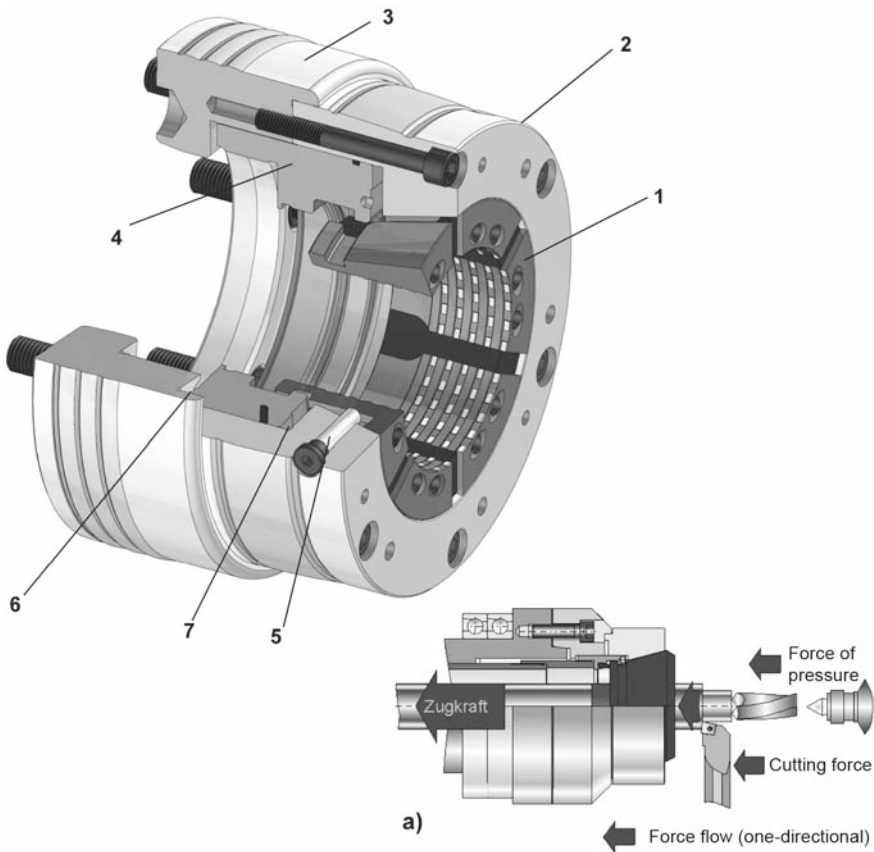


Figure 7.24
 SPANNTOP nova chuck
 1 clamping chuck, 2 chuck body 3 spindle flange, 4 pulling mechanism, 5 radial fixing, 6 clamping reserve with stroke limit, 7 opening path with stroke limit,
 a) chuck mounted in and fixed at the main flange
 (photo by Hainbuch GmbH, Erdmannhäuser Str. 57, 71672 Marbach)

The clamping device shown in the figure acts as a feed rod. The clamping chuck (1) is locked in the basic body of the SPANNTOP nova chuck, and is pulled into the taper of the chuck body (2) on the tensile pipe by means of a clamping cylinder. The spindle flange (3) and feed rod adapter (4) are each specifically adapted to each machine, whereas the clamping chuck (1) is adapted specifically to the tool.

Thanks to the easy transformation of axial clamping force into radial retaining force, the frictional losses may be kept low. We obtain maximal clamping force as a result of the drawing effect.

If the task is to clamp a workpiece from the inside, then it is possible to reset the clamping device to an arbour in a short time by screwing on a segment arbour called the “MANDO Adapt”. The segment clamping bushing is then put on and the arbour is ready for use. These arbours are available in 4 different sizes (clamping diameter 20 - 100 mm).

The third way is to quickly remount the SPANNTOP nova with a jaw adapter (Figure 7.25c) into a three jaw chuck. In this jaw adapter, a taper mechanism prevents tilting out, so that the adapter cannot slip out of the clutch. Adjustable jaws that can be attached enable the clamping diameter of the size 65 three jaw chuck to clamp components up to 120 mm in diameter. The Figure below (Figure 7.25) demonstrates the three clamping variants of the SPANNTOP nova system.

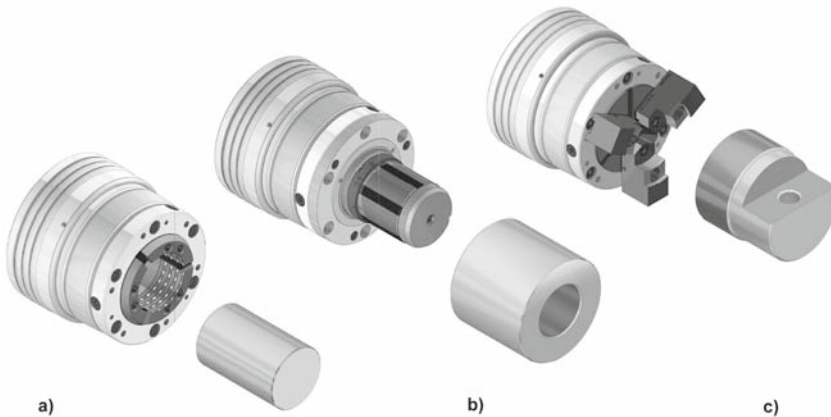


Figure 7.25

Clamping- and manufacturing examples realised with the SPANNTOP nova system a) as a chuck, b) as an arbour, c) as a three jaw chuck (*photo by Hainbuch GmbH, Erdmannhäuser Str. 57, 71672 Marbach*)

7.4.2 Clamping devices to fix the tools

Regardless of the kind of the clamping element, there are 2 basic requirements resulting from tool clamping:

1. The tool (tool tip) should be positioned at the centre of the workpiece. An offset in height changes the working angles (see Chapter 2.4.1.4). The only exception is found in the case of internal turning, where the turning tool should be

positioned slightly above the middle so that the tool's flank face does not press against the workpiece.

2. The tool should be clamped at a short length and with great force. For universal lathes, two types of holders are used in most cases:

7.4.2.1 Quadruple tool holder

The quadruple tool holder (Figure 7.26), which is located on the upper slide and can be rotated, has 4 clamping faces so that it can hold 4 tools simultaneously. These tools can be inserted sequentially by turning the tool holder 90° each time.

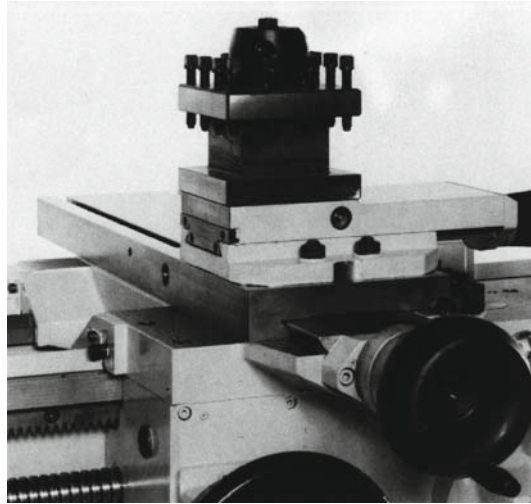


Figure 7.26
Quadruple tool holder at
Boehringer lathe DM 550
(photo by Gebr. Boehringer
GmbH, Göppingen)

7.4.2.2 Quick-change tool holder

This type is used when the machining of the workpiece demands more than 4 tools.

The quick change tool holder is made up of a basic body (Figure 7.27) with ground tooting and an intrinsic adaptable tool holder. The basic body is mounted on the lathe carriage. The adaptable holder with the tool is shifted onto this basic body, and is clamped against the tooting of the basic body with a clamping belt consisting of 2 parts, by means of an eccentric lever.

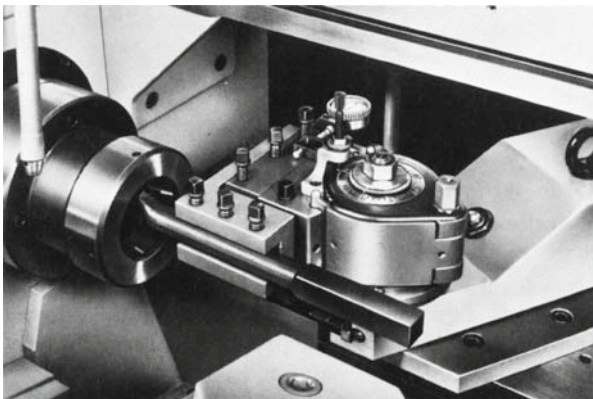


Figure 7.27
Quick change turning tool
holder
(photo by Hahn & Kolb,
Stuttgart)

This makes it possible to change the tool within a few seconds. Quick-change holders are available (Figure 7.28) for all usable turning tool forms.

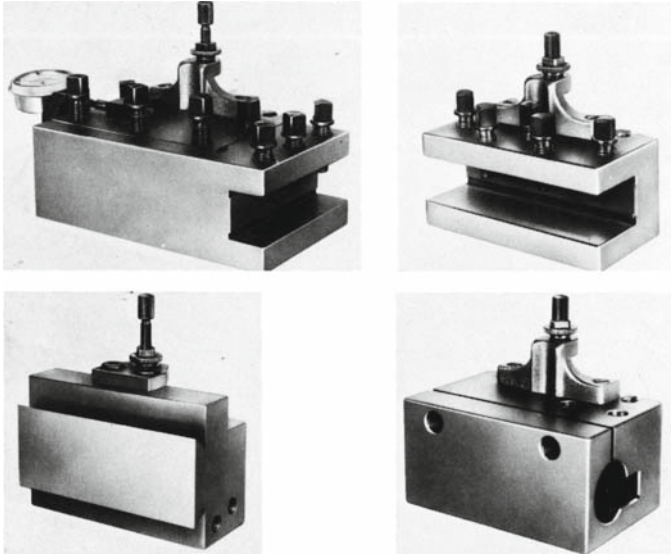


Figure 7.28
Quick-change
holder variants
(photo by Hahn &
Kolb, Stuttgart)

7.5 Calculation of power and forces

Since Chapter 2, “Fundamentals of machining explained for turning”, includes a detailed explanation and discussion of the equations needed for the calculation of power and force, we only want to summarise them here.

7.5.1 Width of cut b (Figure 2.15)

$$b = \frac{a_p}{\sin \alpha}$$

b	in mm	width of cut
a_p	in mm	depth of cut
α	in °	tool cutting-edge angle

7.5.2 Thickness of cut h

$$h = f \cdot \sin \alpha$$

h	in mm	thickness of cut
f	in mm	feed per revolution

7.5.3 Sectional area of chip A

$$A = a_p \cdot f = b \cdot h$$

A	in mm ²	sectional area of chip
-----	--------------------	------------------------

7.5.4 Specific cutting force k_c

$$k_c = \frac{(1 \text{ mm})^2}{h^2} \times k_{c1,1} \times K_\gamma \times K_v \times K_{st} \times K_{ver}$$

k_c in N/mm² specific cutting force
 $k_{c1,1}$ in N/mm² specific cutting force for
 $h = 1 \text{ mm}, b = 1 \text{ mm}, v_c = 100 \text{ m/min}$
 K_γ correction coefficient for the rake angle

$$K_\gamma = 1 - \frac{\gamma_{\text{tat}} - \gamma_0}{100}$$

γ_{tat} in^o actual rake angle for the tool
 γ_0 in^o basic rake angle = 6^o for cutting steel and + 2^o for cutting cast iron
 K_v correction coefficient for cutting speed
 $K_v = 1,15$ for $v_c = 30\text{--}50 \text{ m/min}$ (high speed tools)
 $K_v = 1,0$ for $v_c = 80\text{--}250 \text{ m/min}$ (cemented carbide tools)
 K_{ver} wear factor ($K_{ver} = 1,3$)
 K_{st} compression factor $K_{st} = 1,0$ for external turning
 $K_{st} = 1,2$ for internal turning
 $K_{st} = 1,3$ for recessing and cutting off

7.5.5 Major cutting force F_c

$$F_c = A \cdot k_c$$

F_c in N major cutting force
 A in mm² sectional area of chip
 A_c in N/mm² spec. cutting force

7.5.6 Cutting speed v_c

$$v_c = d \cdot \pi \cdot n$$

n in min⁻¹ speed
 d in m workpiece diameter
 v_c in m/min cutting speed

7.5.7 Machine input power P

$$P = \frac{F_c \cdot v_c}{60 \text{ s/min} \cdot 10^3 \text{ W/kW} \cdot \eta_M}$$

P in kW machine input power
 v_c in m/min cutting speed
 η_M machine efficiency $\eta_M \approx 0.7$ to 0.8
 F_c in N major cutting force

7.6 Determination of machining time t_h

Machining time or machine time is regarded as the period of time within which an immediate step forward in the work progress is achieved. For turning on the centre lathe, it is the period in which the turning tool is in use in order to achieve a machining progress. Once the machine is set up, this time cannot be influenced by the operator, assuming that the predefined technological values made available in production planning are maintained.

For this reason, we refer when discussing machines to machining times that cannot be influenced by human beings.

For all metal cutting techniques, including turning, machining time is determined according to the following equation:

$$t_h = \frac{L \times i}{f \times n}$$

t_h	in min	machining time
L	in mm	total tool path
i		number of cuts
f	in mm	feed per revolution
n	in min^{-1}	speed

Tool path L is the only one different variable.

7.6.1 Cylindrical turning

Before switching on the mechanical feed, the tool is pre-travelled manually or with rapid traverse to a position close to the front of the workpiece (distance l_a). This procedure is the same when the turning tool runs off the workpiece (distance l_u). Only for workpieces with shoulder does $l_u = 0$. Total path relevant for timing is calculated according to the equation below:

$$L = l_a + l + l_u$$

$l_a \approx l_u \approx 2$	mm	
L	in mm	total tool path
l	in mm	workpiece length
l_a	in mm	pre-travel of the tool
l_u	in mm	overtravel of the tool

In this textbook, we assume $l_a \approx l_u \approx 2$ mm.

If other conditions are given in practice, it is possible to match the values to the real situation.

Speed n_c can be calculated from cutting speed.

$$n_c = \frac{v_c \times 10^3 \text{ mm/m}}{d \times \pi}$$

n_c	in min^{-1}	speed
v_c	in m/min	cutting speed (taken from tables)
d	in mm	workpiece diameter

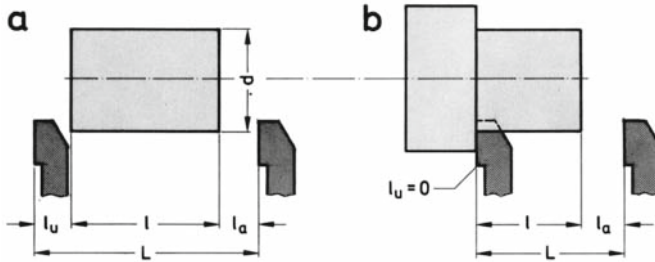


Figure 7.29
Travels in cylindrical turning
a) if the part is turned over the whole length
b) for workpieces with shoulder

On the lathe, adjust the speed value to the value nearest to the calculated speed.

7.6.2 Facing

In facing, the same conditions as for cylindrical turning are in principle valid; the only difference for the full cylinder is $l = d/2$.

$$L = l_a + l = l_a + \frac{d}{2}$$

L	in mm	total travel of the tool
l_a	in mm	pre-travel
d	in mm	workpiece diameter

For the hollow cylinder, the following is valid:

$$L = l_a + l + l_u = l_a + \frac{D-d}{2} + l_u$$

When calculating the speed for facing, then we assume the mean diameter d_m .

$$n = \frac{v_c \times 10^3 \text{ mm/m}}{d_m \times \pi}$$

n	in min^{-1}	speed
v_c	in m/min	cutting speed
d_m	in mm	mean workpiece diameter

Mean workpiece diameter d_m (Figure 7.30) can be calculated for the full- and hollow cylinder as follows:

Full cylinder	$d_m = \frac{d}{2}$	Hollow cylinder	$d_m = \frac{D+d}{2}$
---------------	---------------------	-----------------	-----------------------

For speed calculation, when introducing the workpiece mean diameter instead of the outer diameter, higher speed values are obtained.

As a result, cutting speed approaches zero only in the immediate vicinity of the workpiece centre point.

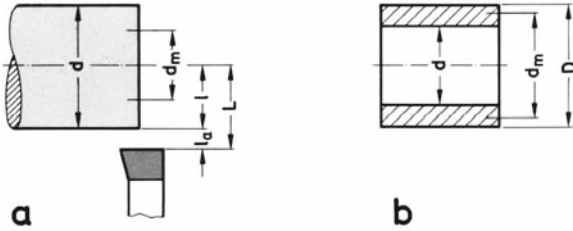


Figure 7.30
Length values and mean diameters become a part of the calculation in facing.
a) for a full cylinder,
b) for a hollow cylinder

7.6.3 Thread turning

Thread turning is a type of cylindrical turning, carried out with a form turning tool, in which feed corresponds to the thread pitch to be generated.

Only in the case of multiple threads is it necessary to additionally consider number of threads.

$$t_h = \frac{L \times i \times g}{p \times n}$$

- t_h in min machining time
- L in mm total tool path
- i number of cuts
- i in mm thread pitch
- n in min^{-1} speed
- g number of starts of the thread

The number of cuts i can be determined from depth of thread and depth of cut.

$$i = \frac{t}{a} \quad (\text{For depths of thread } t \text{ see Table 7.14})$$

- t in mm depth of thread
- a_p in mm depth of cut

Table 7.3 Depth of cut in mm, at rough- and finish turning

Machining	Metric and Whitworth thread	Acme thread
Roughing	0.1 to 0.2	0.08 to 0.15
Finishing	0.05	0.05

7.7 Determination of the cycle time

If the machine follows an automatic procedure, then the complete time span to execute this sequence cannot be influenced. This so-called cycle time is composed of the machining time (7.6.) and the individual time values needed for pre-traveling, infeed, taking off and return.

$$t_z = t_h + (t_{An} + t_{Zu} + t_{Ab} + t_{Ru}) i$$

All individual time components are calculated according to

$$A = \frac{\text{Distance travelled}}{\text{Travel speed}} \times \text{Number of cuts}$$

Example (Figure 7.31):

$$t_z = t_h + \left(\frac{l_{An}}{u_E} + \frac{l_{Zu1}}{u_E} + \frac{l_{Ab1}}{u} + \frac{l_{Ru1}}{u_E} + \frac{l_{Zu2}}{u_E} + \frac{l_{Ab2}}{u} + \frac{l_{Ru2}}{u_E} \right) i$$

- u_E in mm/min rapid traverse rate according to manufacturer's documentation
- u in mm/min feed rate $u = s \cdot n$
- l_{Au} in mm pre-travel
- l_{Zu} in mm infeed travel (for approaching)
- l_{Ab} in mm taking off travel; in the example, it is necessary to take off at feed rate
- l_{Ru} in mm return travel

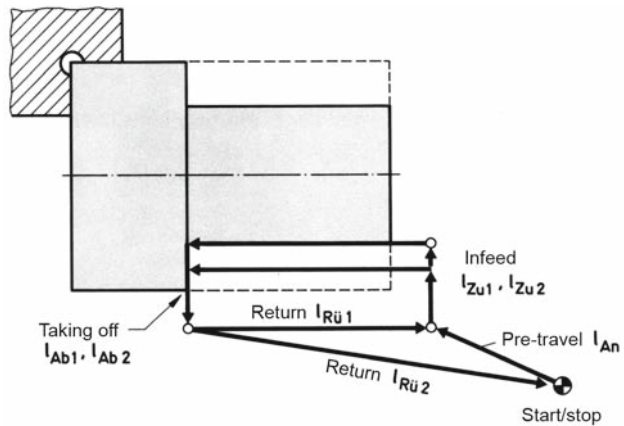


Figure 7.31
Travelling paths in case of automatic procedure

7.8 Turning tools

7.8.1 Tool design types

7.8.1.1 Formation of the tool point

A turning tool consists of shank and cutting head. Depending on the position of the tool point (cutting head) in relation to the shank, we subdivide this category into straight-lined, bent and offset turning tools.

Another characteristic used for differentiation is the cutting direction. A turning tool that cuts from the right to the left is called a right turning tool (chisel), while, conversely, a turning tool, that cuts from the left to the right is called a left turning tool. Figure 7.32 elucidates the most significant turning tool shapes. The shank cross sections assigned are defined in DIN 770. The shank may be quadratic or rectangular. In the case of the rectangular shafts, the shank's height- to width-ratio is $h : b = 1.6 : 1$.

Denomination of shanks:

quadratic: $b = h = 16 \rightarrow 16 q$

rectangular: $h = 25, b = 16 \rightarrow 25 h$

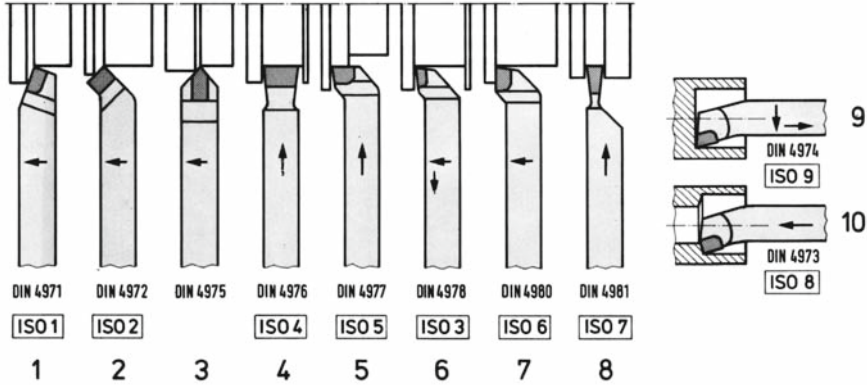


Figure 7.32

Denomination of turning tools

1 straight-lined-, 2 bent-, 3 acute-, 4 wide-, 5 offset end face-, 6 offset corner cutting-, 7 offset side cutting-, 8 end-cut-, 9 internal – corner cutting-, 10 internal turning tool.

The turning tools 1, 2, 5, 6, 7 are right turning tools, because they cut the right side of the workpiece.

For the turning tools shown in Figure 7.32, the cemented carbide cutting tip is brazed. For these turning tools, if it is necessary after regrinding them repeatedly, to exchange the cemented carbide tip, then their use is very costly and time-consuming. Consideration of ways to reduce the tool costs for recovery of these tools led to the development of the clamp-type tool holder.

7.8.1.2 Clamp-type tool holder

In the clamp-type tool holder, the cemented carbide cutting tips are retained by a clamping system. The indexable inserts (Figure 7.33) are available in a wide variety of shapes and sizes, as well as with different rake angles and tool orthogonal clearances. Thus, for example, a quadratic cutting tip with a rake angle of 0° has 8 cutting edges. By turning the insert in the clamp-type tool holder or by reversing the tip, it is possible to bring into engagement 8 cutting edges in turn. Due to this opportunity to change the tip, these plates are called cutting tips or indexable inserts.

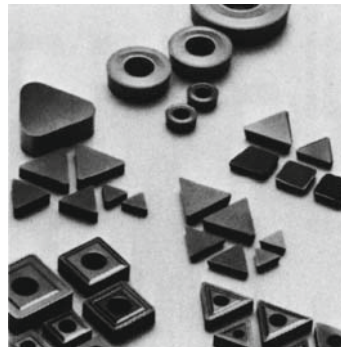


Figure 7.33

Forms and sizes of cutting tips
(photo by Hertel, 90766 Fürth)

The names of the cutting tips are defined in DIN 4987/ISO 1832.2, and the type of the clamping system is specified in DIN 4983/ISO 5610 (Figure 7.34)

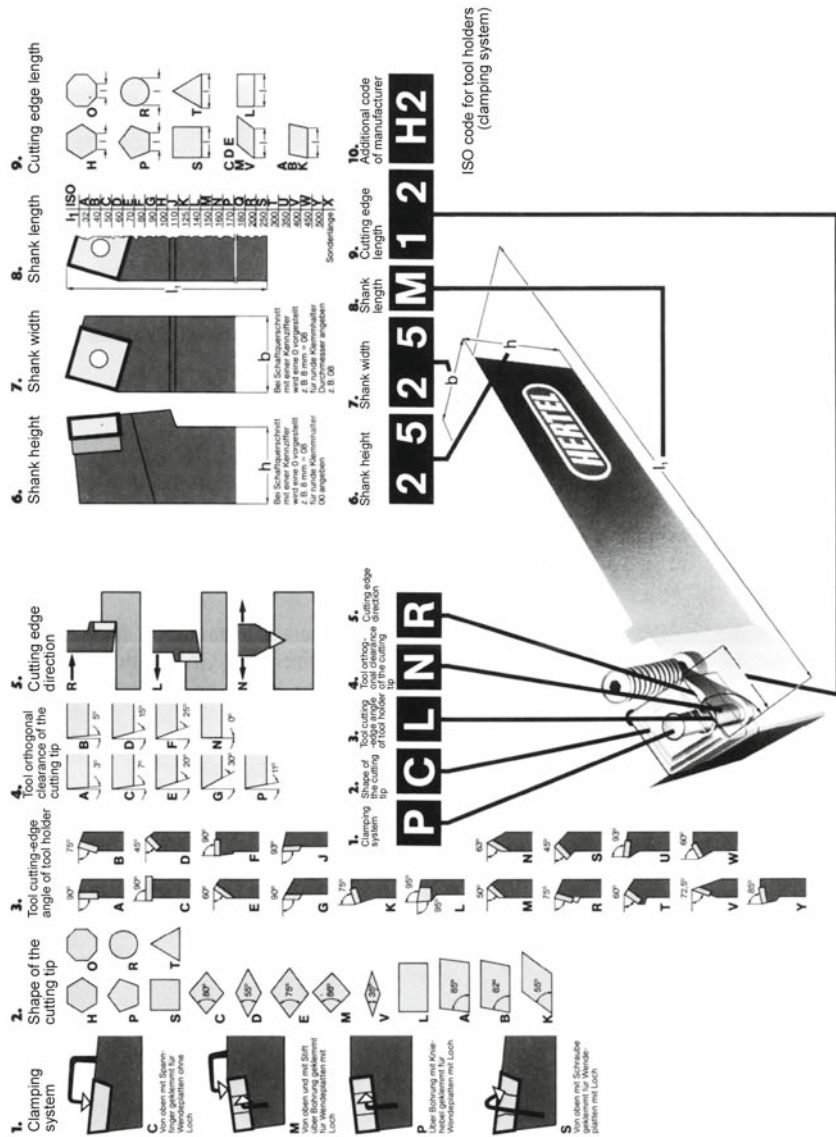


Figure 7.34 ISO coding of the clamping systems and indexable inserts (photo by Hertel, 90766 Firth)

The cutting tip dimensions are additionally standardised in DIN 4968, 4969 and 4988. DIN 4968 and DIN 4988 standardise the cutting tips made of cemented carbide, and DIN 4969 defines those made of ceramic. Both standards are applicable for triangular tips with a tool included angle of 60°, and quadratic tips with a tool included angle of 90°, rhombic with 80°, 55° and 35°, as well as for circular cutting tips.

Table 7.4 summarises the clamping principle of the clamping systems.

Table 7.4 Type of clamping for clamp-type tool holders

Clamping system	Type of clamping	Cutting tip application
<i>C</i>	Clamped from the top with toe dog	Without hole
<i>M</i>	Clamped from the top and via hole	With cylindrical hole
<i>P</i>	Clamped via hole, clamping by gripping lever	
<i>S</i>	Screwed through the hole	With countersinking for mounting

Clamping system C: This toe dog is used for positive indexable inserts according to DIN 4968. This clamping is characterised by its compact design and easy handling. The toe dog is adjustable in height and thus allows for the optional use of additional chip curlers.

Clamping system P: Clamping via gripping lever is used for negative cutting tips with a hole according to DIN 4988 and positive circular indexable inserts, from 20 mm diameter upward. In the case of tips with one- or two-sided chip breakers, we obtain positive rake angles from 6° to 18° . The advantages of this clamping consist of a high chucking stroke and quick change of the inserts.

Clamping system S: Screw clamping is a small-sized clamping system with high functional reliability. This cost-efficient design can function with a minimum of spare parts. The clamping system S is applied for positive cutting tips with countersinking hole according to DIN 4967.

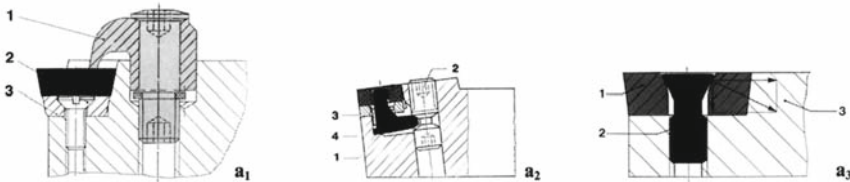


Figure 7.35

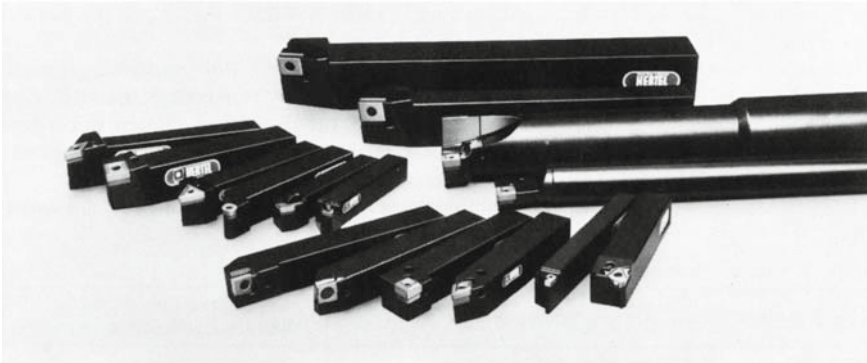
The clamping systems mostly in use for cemented carbide indexable inserts

a₁) *clamping system C*: 1 toe dog set, 2 countersunk screw, 3 resting plate

a₂) *clamping system P*: 1 gripping lever, 2 screw, 3 resting plate, 4 sleeve

a₃) *clamping system S*: 1 indexable insert, 2 lock screw, 3 shank

(photo by Widia-Fabrik Essen)

**Figure 7.36**

Clamp-type tool holder for different forms and sizes of indexable inserts
(photo by Hertel, 90766 Fürth)

7.8.1.3 Special turning tool forms for thread turning

a) External thread

To generate external threads, we normally use an acute turning tool according to DIN 4975, for which the drill-point angle corresponds to the flank angle of the thread to be created.

Both cemented carbide- and high speed steel tools are used for thread cutting.

In the case of the high speed steel tools, thread turning tools are preferentially used. For the holder depicted in Figure 7.37, the exchangeable blade has a constant flank angle over its total length. When regrinding, the blade is ground only at the top, at the plane rake face. Consequently, the thread profile, which is not reground, is fully retained until the blade has been utilized.

The lead angle is adjusted by means of the holder head.

Formed wheels are also used instead of the formed blade. Such formed wheels (Figure 68a) have diameters from 30 to 100 mm. Even in this case, it is still necessary to regrind the thread profile on the rake face. A formed wheel like this can be reground down to $\frac{1}{4}$ of its circumference.

When thread turning with the formed wheel, the formed wheel's centre has to be located at a distance x above the workpiece centre. This is necessary to allow free cutting of the formed turning tool. Tool orthogonal clearance α results from the tangent to the radius of the formed wheel, at the point of contact with the workpiece and the vertical. The required offset in height x (Figure 68b) can be computed.

$$x = \frac{D}{2} \cdot \sin \alpha$$

α	in°	tool orthogonal clearance
D	in mm	diameter of the formed wheel
x	in mm	formed wheel's offset in height

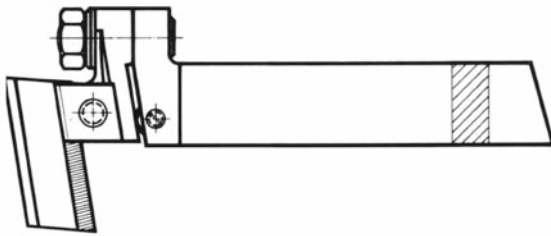
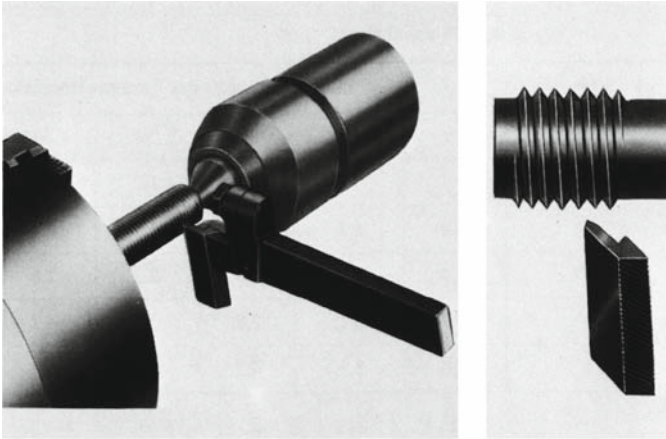


Figure 7.37

Turning tool holder with inserted formed blade
 a) side view of the holder with blade,
 b) formed blade for metric threads

(photo by Komet Stahlhalter und Werkzeugfabrik, 74351 Besigheim)

From the following Table 7.5, we can read the required offset in height x for different tool orthogonal clearances.

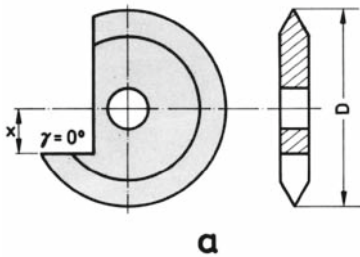


Figure 7.38a
 Wheel turning tool

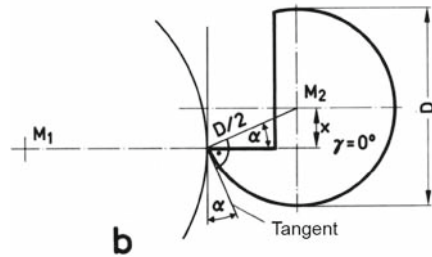


Figure 7.38b
 Formation of the tool orthogonal clearance for the wheel turning tool. M 1 workpiece centre, M 2 tool centre, D Ø of the formed wheel, x offset in height, α tool orthogonal clearance

Table 7.5 Offset in height x in mm as a function of the formed wheel diameter in mm at given tool orthogonal clearance α

Tool orthogonal clearance α°	Diameter D of the form turning tool in mm						
	10	30	40	50	60	70	80
3°	0,3	0,8	1,1	1,3	1,6	1,8	2,1
4°	0,4	1,1	1,4	1,7	2,1	2,4	2,8
5°	0,4	1,3	1,8	2,2	2,6	3,0	3,5
8°	0,7	2,1	2,8	3,5	4,2	4,9	5,6
12°	1,0	3,1	4,2	5,2	6,2	7,3	8,3

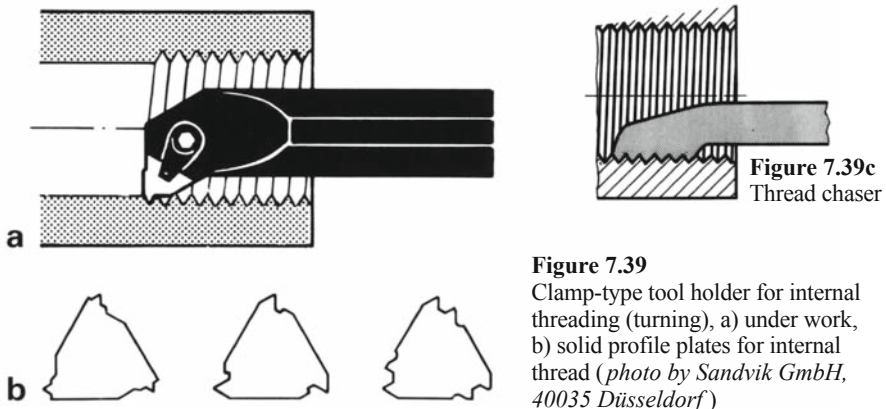
When cutting steel and grey cast iron, the rake angle γ is 0° . During form turning, the profile of the tool is only formed at a rake angle of 0° . For other rake angles, we obtain a profile distortion, which has to be compensated for by a profile correction on the tool.

b) Internal thread

The single-point internal threading tool is a bent form turning tool. It can be made of high speed steel or as a cemented carbide tool.

Even for this application, the clamp-type tool holder with special fully profiled tips for threads (Figure 7.39) is becoming more and more established.

Thread chasers are multi-cutting edge tools. Here, metal cutting work in thread cutting is split among several cutting edges. As a result, the multi-edged thread chaser is able to generate the thread (Figure 7.39c) in one pass. The internal thread chaser can also be formed as a multi-edged circular forming tool.



7.8.1.4 Form turning tool

A form turning tool to manufacture any workpiece form is elucidated in Figure 7.40.

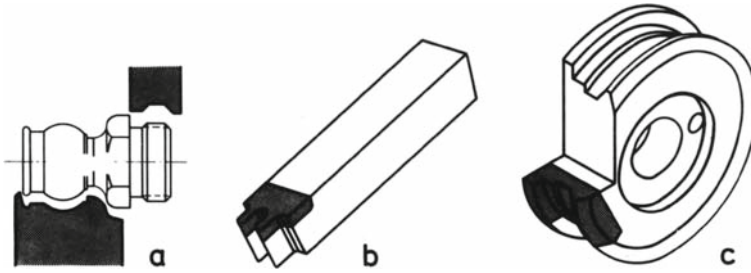


Figure 7.40
a workpiece generated with profile turning tool, *b* profile turning tool with cemented carbide tip, *c* profile turning wheel (photo by Hufnagel, Nürnberg)

7.8.1.5 Copying tools

Turning tools for copying are made with tool included angles of 55° or 60° .

Clamp-type tool holders with chip curlers, in which it is possible to vary the width of chip-breaking shoulder, are primarily used. The WIDAX holders of the SKP type, shown in Figure 7.41, have rhombic cutting tips, tool included angles 55° or 60° , and positive rake angle 6° .

These holders are suitable for all copying technologies (longitudinal, internal and external form turning), as well as corresponding contour turning (profile turning) processes on NC lathes.

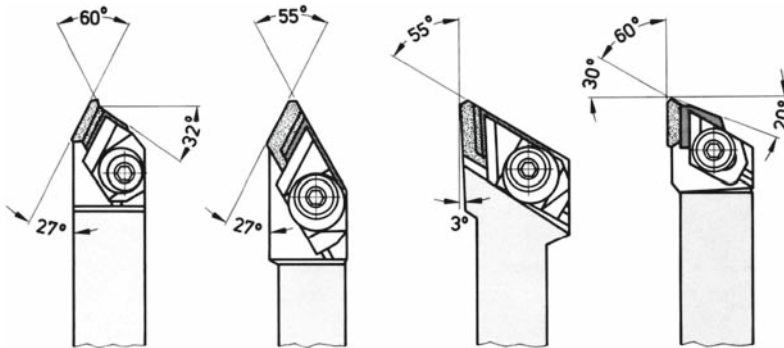


Figure 7.41
 Clamp-type tool holders for form turning, for shapes with positive rake angle (photo by Widia-Fabrik, Essen)

7.8.2 Chip-breaking shoulders

Chip-breaking shoulders are expected to affect chip form and chip flow so that optimal cutting conditions for turning are provided, both in terms of the tool and of the workpiece.

7.8.2.1 Halved cone angle φ

The chip-breaking shoulder (Figure 7.42) may be located in parallel or at an angle to the major cutting edge.

a) *Parallel halved-cone angle $\varphi = 0^\circ$*

Plus: easy to machine

Minus: chip flows against the area of cut and damages the workpiece surface.

b) *oblique: $\varphi = \pm 8$ to $\pm 15^\circ$*

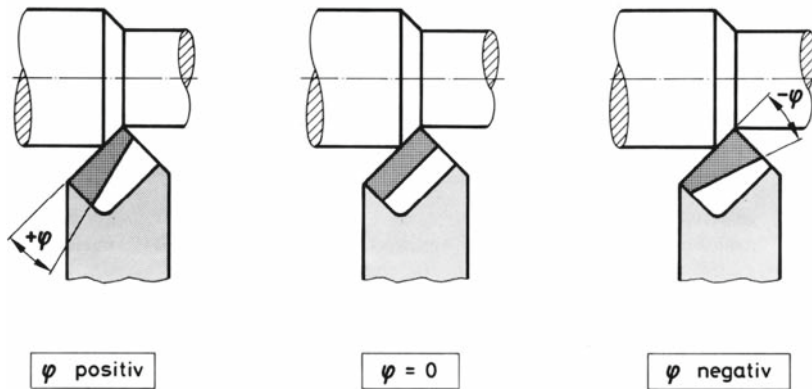


Figure 7.42

Halved cone angle of the chip breakers

b1) *Halved cone angle negative*

In the case of a negative halved-cone angle, width of the chip-breaking shoulder increases toward the outer edge corner.

Applied: for roughing cuts

Reason: chip breaking is made easier.

Disadvantage: chips flow against the turned surface (Figure 7.43) and scratch it.

For this reason, we may use the negative halved cone angle only for roughing, since there surface quality plays only a minor role.

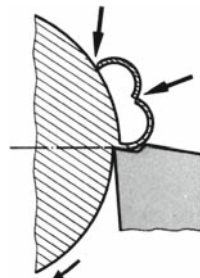


Figure 7.43

Chip flowing against the workpiece surface with negative halved cone angle

b2) *Halved cone angle positive*

Halved cone angle is positive, if the width of the chip-breaking shoulder decreases toward the outer edge corner

Applied: for finishing cuts

Reason: chip flows away from the workpiece surface. Consequently, it is also not damaged by the chip.

Disadvantage: breaking of chips becomes more difficult

7.8.2.2 Dimensions of the chip-breaking shoulder

We distinguish between 2 formation types in the case of chip-breaking shoulders (Figure 7.44).

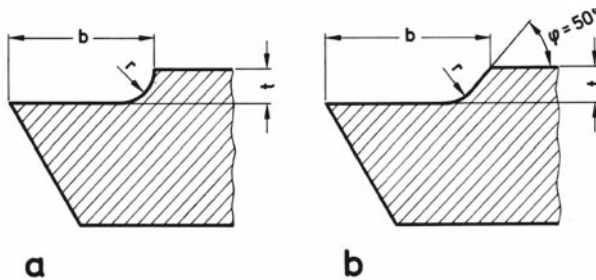


Figure 7.44
Dimensions of chip breaker b in mm width, t in mm depth, r in mm radius, ϕ in $^\circ$ angle of lapping

In one type (Figure 7.44aa), the chip-breaking shoulder ends with a radius r . The other has an oblique chip inflow surface. Chip flow angle of this surface is approx. 50° .

Due to the inclined flow, wear on the chip inflow edge is slightly less.

The chip's curvature radius achieved by the chip-breaking shoulder mainly depends on width b and depth t of the chip-breaking shoulder.

Table 7.6 illustrates the width- and depth- dimensions for the chip-breaking shoulders.

Table 7.6 Dimensions of the chip-breaking shoulders as a function of feed f in mm

Material strength in N/mm ²	Width b at feed s		Depth t in mm	Radius r in mm	
	$f < 0,5$ mm	$f > 0,5$ mm		Form a	Form b
700	$10 \cdot s$	$7,5 \cdot s$	0,7	1,2	0,5
700–1000	$8,5 \cdot s$	$6 \cdot s$	0,5	0,9	0,5
1000	$7,5 \cdot s$	$5 \cdot s$	0,4	0,7	0,5

In the case of clamp-type tool holders for cutting tips, it is possible to install a chip curler, which is placed on the cutting tip, instead of the chip-breaking shoulder (sintered in) (Figure 7.45).

This chip curler plate can be shifted. Thus it becomes possible to optimally adjust the width of the chip-breaking shoulder.

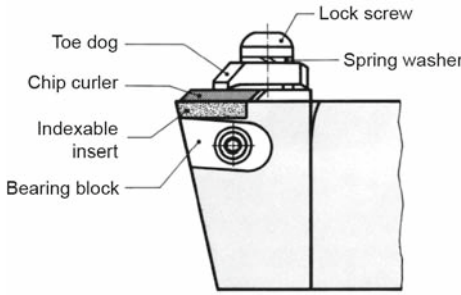


Figure 7.45
Chip curler plates on clamp-type tool holders
(photo by Widia-Fabrik, Essen)

7.8.3 Chamfers on the turning tool

7.8.3.1 Cutting edge chamfer

This is understood as a slight breaking or rounding of the cutting edge. Chamfer width is between 0.1 and 0.2 mm. The chamfer angle ranges from -10 to -20° .

7.8.3.2 Reinforcement chamfers

Both rake face- and flank face chamfer reinforce the wedge. The rake face chamfer creates a cutting edge geometry that combines two advantages:

1. the large rake angle enhances chip flow.
2. the small (up to negative) chamfer rake angle γ_f reinforces the wedge, improves heat removal and diminishes chipping (Figure 7.46).

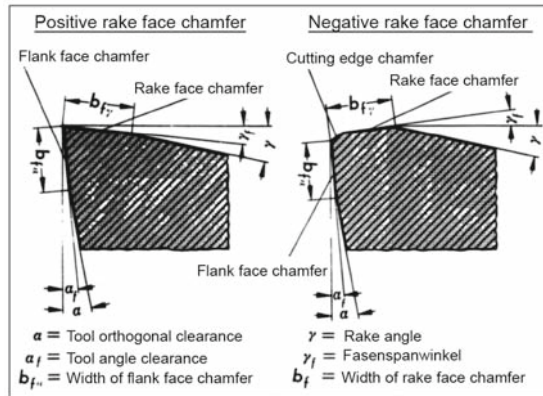


Figure 7.46
Chamfers on the wedge
(photo by Widia-Fabrik, Essen)

The width of the rake face chamfer must not be too high, or else the chip can no longer flow on the rake face.

For tool cutting-edge angles between 60° and 90° , we can calculate the width of the rake face chamfer as follows:

$$b_{f_\gamma} \approx 0,8 \cdot f$$

b_{f_γ} in mm width of the rake face chamfer
 f in mm feed per revolution

7.9 Failures in turning

Table 7.7 Failures and their causes in turning

7.9.1 Tool failures		
Consequence for the tool	Cause of the failure	Remedy
Tool top chipping (in the case of cemented carbide tools)	Too small wedge angle, results in accumulation of heat	Increase wedge angle or affix chamfers to rake angle and flank faces
	Tool vibrations resulting from too long clamping	Clamp at shorter length or select greater shank cross section
Cemented carbide cutting edge is chipping	Vibrations, for example because of too much backlash in the longitudinal guideways or in the main spindle bearing	Readjust backlash in guidances or bearings
	Vibrations, for example due to machine overload	Use another machine with greater stiffness
Large flank face wear	Tool orthogonal clearance too small tool presses	Increase tool orthogonal clearance
	Tool tip is above the centre of workpiece axis – thus efficient tool orthogonal clearance is too small	Correct tool height adjustment
Tool tip in the case of high speed tools fuses off	Cutting speed too high – creates too much heat	Diminish v_c
	Too high sectional area of chip – Consequence: too great forces – too high heat	Diminish chip cross section, above all, reduce depth of cut
Strong crater wear	Too high cutting speed	Diminish v_c
Tool life too short	Too high cutting speed	Diminish v_c

7.9.2 Workpiece failures		
Consequence for the workpiece	Cause of the failure	Remedy
workpiece becomes noncircular	Workpiece deflects – wrong tool cutting-edge angle	Increase tool cutting-edge angle
	Centre in main spindle wobbles (runs out)	Check taper in main spindle and remove dust
	Workpiece inexactly centred	Recentre
	Longitudinal guidances or main spindle bearing has too much backlash	Readjust guidances or main spindle bearing
	Clamping force deforms tube-shaped workpiece	Reduce clamping force Diminish chip cross section

Consequence for the tool	Cause of the failure	Remedy
Workpiece surface becomes wavy	Vibrations, for example because guidance backlash is too great	Readjust guidances
	Incorrect tool clamping (vibrations)	Clamp tool shorter
	Too high metal removal rate results in vibrations in the machine	Diminish chip cross section or change v
Workpiece deflects	Stationary steadyrest incorrectly adjusted	Readjust steadyrest jaws
Surface roughness too great – obvious grooves	Too high feed and too small peak radius on the turning tool	Diminish feed Increase peak radius
Bright stripes on workpiece	Bright braking due to fused off tip on the high speed steel turning tool	Diminish v
Workpiece becomes conical during turning between centres	Centres don't align	Readjust tailstock sidewise

7.10 Reference tables

The recommended values for v_{15} in the Tables 7.8 and 7.9 are applicable for depths of cut from $a_p = 1$ to 4 mm. If depth of cut is greater than 4 mm (up to about 10 mm), it is necessary to reduce these values by about 8 %. Allowable cutting speeds are valid for a tool life $T = 15$ min.

These cutting speeds can be transformed to allow for a tool life of $T = 8$ min, $T = 30$ min, $T = 60$ min with the following factors.

$v_8 = v_{15} \cdot 1,25$
$v_{30} = v_{15} \cdot 0,8$
$v_{60} = v_{15} \cdot 0,6$

Currently, because of the short tool change times for clamp-type tool holders, we predominantly work with tool life values from:

$$\underline{T = 15 \text{ to } 30 \text{ min.}}$$

In many cases, though not exclusively, cam-controlled automatic lathes work with tool life values from $T = 240$ to 480 min. Numerically-controlled lathes with short reset times operate with v_{15} to v_{60} values.

Depending on the work required for reset or setup time and the number of workpieces to be machined, cutting speeds and thus the tool life values are adapted to the production conditions.

Table 7.8 Cutting speeds v_c for steels at turning with cemented carbide for $T = 15$ min (v_{c15} values)

Material	Strength or hardness in N/mm ²	Cutting material	a_p in mm	Feed f in mm						Wear criterion	Transformation factors for			
				0,1	0,16	0,25	0,4	0,63	1,0		$T = 8$	$T = 30$	$T = 60$	
S 185-S 275 JR C 15-C 22 mild- and case hardening steel	400—500	P 10	1	450	420	400	380	—	—	VB 0,2 K 0,3	1,25	0,80	0,60	
			2	420	400	370	350	—	—					
			4	—	370	350	330	310	300					—
			1	440	400	390	380	—	—					VB 0,4 K 0,3
			2	380	350	330	310	290	—					
			4	350	330	310	290	270	250					
E 295 C 35-C 45, Ck 35 mild steel and case hardening, heat-treated steel	500—800	P 10	1	370	340	320	300	—	—	VB 0,5 K 0,3	1,20	0,80	0,65	
			2	340	310	290	280	260	—					
			4	320	290	280	260	240	—					
			1	320	290	270	250	—	—					VB 0,4 K 0,3
			2	290	270	250	230	210	—					
			4	280	250	230	210	190	180					
16MnCr5 20MnCrS5 tool and heat-treated steel	1600—2000 HB	P 30	1	—	—	—	—	—	—	VB 0,5 K 0,3	1,15	0,85	0,70	
			2	—	260	230	200	180	—					
			4	—	240	210	190	170	150					
			1	330	290	260	230	—	—					VB 0,2 K 0,3
			2	310	270	240	220	200	—					
			4	280	250	220	200	180	170					
E 335 Ck 45, Ckk 60 mild- and heat-treated steel	750—900	P 20	1	300	270	240	220	—	—	VB 0,4 K 0,3	1,15	0,85	0,70	
			2	270	240	220	200	180	—					
			4	250	220	200	180	160	140					
			1	—	—	—	—	—	—					VB 0,5 K 0,3
			2	—	220	190	160	140	120					
			4	—	200	170	140	130	110					
50CrV4 42CrMo4 50CrMo4 heat-treated steel	1000—1400	P 30	1	—	—	—	—	—	—	VB 0,5 K 0,3	1,15	0,85	0,70	
			2	—	220	190	160	140	120					
			4	—	200	170	140	130	110					

Table 7.9 Cutting speeds v_c for cast steel, grey cast iron and non-ferrous metals for turning for $T = 15$ min ($v_{c,15}$ values)

Material	Strength or hardness in N/mm ²	Cutting material	a_p in mm	Feed f in mm						Wear criterion	Transformation factors for		
				0,1	0,16	0,25	0,4	0,63	1,0		$T = 8$	$T = 30$	$T = 60$
GE 200-GE 240 cast steel	300—450	P 10	1	380	350	320	300	—	—	VB 0,3 K 0,3	1,20	0,80	0,65
			2	360	330	300	280	—	—				
			4	330	300	280	260	230	210				
		M 20	1	—	—	220	190	180	—	VB 0,3 K 0,3			
			2	—	—	210	180	150	130				
			4	—	—	200	170	140	120				
GJL 100-GJL 400 grey cast iron	1400—1800 HB	M 10	1	300	270	250	230	—	—	VB 0,4 K 0,3			
			2	280	250	230	210	190	—				
			4	270	250	230	210	200	180				
		K 10	1	230	200	180	160	—	—	VB 0,4 K 0,3			
			2	210	190	170	150	130	—				
			4	190	170	150	130	110	100				
GJL 100-GJL 400 grey cast iron	2000—2200 HB	K 20	1	150	130	110	100	—	—	VB 0,6			
			2	140	120	100	90	80	—				
			4	130	110	100	90	80	70				
		K 10 K 20	1	600	550	500	—	—	—	VB 0,4 K 0,3			
			2	550	500	450	420	400	—				
			4	500	480	450	420	400	380				
Al alloy 9-13 % Si	600—1000 HB	SS	1	120	90	70	50	40	35				
			2	100	80	60	40	30	30				
			4	—	—	—	—	—	—				
		K 10	1	550	500	480	450	—	—	VB 0,4 K 0,3			
			2	500	480	460	420	380	340				
			4	—	—	400	370	340	300				

Table 7.10 Cutting speeds for turning with ceramic tools
(excerpt from company documentation, Degussa, Frankfurt)

Material	Strength R_m (N/mm ²)	Feed f (mm)	Cutting speed v_c (m/min)	Type of machining
Mild steels: E 295–E 360 Tempering steels: C 35, CK 35, C 45, CK 45 a.o.	500 ... 800	0,3–0,5 0,1–0,3	300–100 500–200	roughing finishing
Tempering steels: C 60, CK 60, 40 Mn 4, 30 Mn 5, 37 MnSi 5, 34 Cr 4, 41 Cr 4, 25 CrMo 4, 34 CrMo 4, a.o.	800 ... 1000	0,2–0,4 0,1–0,3	250–100 400–200	roughing finishing
Tempering steels: 42 MnV, 42 CrMo 4, 50 CrMo 4, 36 CrNiMo 4, 34 CrNiMo 6 a.o.	1000 ... 1200	0,2–0,4 0,1–0,3	200–100 350–200	roughing finishing
Unalloyed cast steel GE 260 Alloyed cast steel G 20 Mn 5 G 24 MnMo 5 G 22 CrMo 5 a.o.	500 ... 600	0,3–0,6 0,1–0,3	300–100 500–200	roughing finishing

Material	Hardness HRC	Feed f (mm)	Cutting speed v_c (m/min)	Type of machining
Hot forming tool steels, Die steels	45–55	0,05–0,2	150–50	Finish-turning
Cold work steels, ball bearing steels	55–60	0,05–0,15	80–30	Finish-turning
Cold work steels, High speed steels	60–65	0,05–0,1	50–20	Finish-turning

Table 7.10 Cutting speeds for turning with ceramic tools
(excerpt from company documentation, Degussa, Frankfurt)

Material	Brinell-hardness HB	Feed f (mm)	Cutting speed v_c (m/min)	Type of machining
GJL 100–GJL 250	1400 ... 2200	0,3–0,8 0,1–0,3	300–100 400–200	Roughing Finishing
GJL 300 Special cast iron 40 GG alloyed	2200 ... 3500	0,2–0,6 0,1–0,3	250–80 300–100	Roughing Finishing
Brass: Ms 63, (CuZn 37)	800	0,3–0,8 0,1–0,3	500–300 1000–400	Roughing Finishing
Aluminium alloys	600 ... 1200	0,3–0,8 0,1–0,3	1000–600 2000–800	Roughing Finishing

Table 7.11 Cutting speeds for turning with diamond
(excerpt from company documentation, Winter & Sohn, Hamburg)

Material	f in mm	a_p in mm	v_c in m/min
Al alloy (9–13 % Si)	0,04	0,15	300–500
Al- extrusion special alloy 12 % Si–120 HB	0,25	0,4	200–500
Electrolyte copper	0,05–0,1	0,05–0,4	140–400
Brass	0,03–0,08	0,5–1,4	80–400
Plastics PTFE with 20% glass fibre	0,12–0,18	0,5–3,0	130–170

Table 7.12 Cutting speeds v_{60} in m/min and feed values f in mm for automatic lathes (excerpt from reference tables for Index-Werke KG, Hahn und Tessky, Esslingen)

Material →	Al alloy		CuZn 37		GJL 200 GJL 300		Free cutting steel		Mild steel and heat-treated steels					
	v_c	f	v_c	f	v_c	f	v_c	f	< 500 N/mm ²	600–850 N/mm ²	850–1000 N/mm ²	v_c	f	
Cutting technology	v_{60} values for high speed steel tools, f values for high speed steel- and cemented carbide tools													
Cylindrical turning and facing	160–190	0,15–0,25	60–110	0,10–0,25	20–30	0,1–0,2	50–80	0,1–0,2	30–50	0,1–0,2	30–40	0,1–0,2	25–35	0,1–0,2
Recessing	160–180	0,04–0,08	60–100	0,04–0,08	20–30	0,03–0,05	50–80	0,03–0,05	30–50	0,02–0,03	30–40	0,02–0,03	25–35	0,02–0,03
Cutting off	160–180	0,07–0,12	60–100	0,04–0,08	20–30	0,06–0,1	50–80	0,04–0,08	30–50	0,03–0,07	25–35	0,03–0,07	25–35	0,02–0,03
Drilling														
Ø 2,5–4,0	130–150	0,1	70–120	0,08	15–20	0,08	55–80	0,06	35–40	0,07	20–30	0,07	20–25	0,04
Ø 4,0–6,3		0,13		0,10		0,1		0,10		0,08		0,08		0,05
Ø 6,3–10,0		0,14		0,12		0,12		0,12		0,10		0,10		0,06
Ø 10,0–16,0		0,17		0,14		0,14		0,14		0,11		0,11		0,07
Die and tap	40–60	–	30–40	–	5–8	–	6–9	–	3–4	–	3–4	–	2–3	–
Cutting speeds v_{60} in m/min for cemented carbide tools														
Cylindrical turning and facing	250–500		200–400		50–100		120–180		100–150		100–150		70–150	
Recessing and cutting off	250–400		200–350		40–80		100–160		80–120		70–100		50–100	

Table 7.13 Cutting speeds for thread cutting of external threads

Thread	v_c in m/min	
	HS	HM
Metric thread	5–7,5	70
Metric fine screw thread	5–9	70–90
Acme thread	5–8	70

The smaller v values have to be assigned to the smaller thread diameters.
 In the case of internal threads, allowable cutting speeds diminish by 20%.

Table 7.14 Depths of thread t in mm at metric threads according to DIN 13

Thread	M 8	M 10	M 12	M 16	M 20	M 24	M 27	M 30
Depth of thread t in mm	0,81	0,97	1,13	1,29	1,62	1,95	1,95	2,27
Number of cuts	10	11	12	14	15	16	16	18

Diagram to determine speed

Example:

Given:

$d = 100 \text{ mm}$

$v_c = 35,5 \text{ m/min}$

Sought for: n

Approach:

$n_c = 112 \text{ min}^{-1}$

Figure 7.47 Diagram to determine speed at given cutting speed v_c and predefined turning diameter d

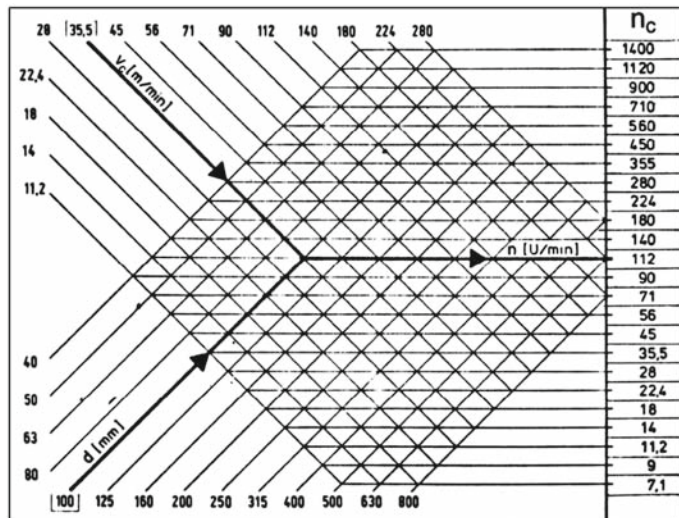


Table 7.15 Tool angle for turning with high speed steel- and cemented carbide tools

Material	Strength or hardness HB in N/mm ²	High speed steel		Cemented carbide			
		α°	γ°	α°	γ°	γ_f°	λ°
Mild- and case-hardening steel S 185, S 275 JR C 15-C22	400–500	8	14	6–8	12–18	6	–4
Mild- case hardening heat-treated steel E 295–E 335 C 35–C 45	500–800	8	12	6–8	12	3	–4
Mild steel and heat-treated steel E 360 C 60	750–900	8	10	6–8	12	0 to +3	–4
Tool- and heat-treated steel 16 MnCr 5 30 Mn 5	850–1000	8	10	6–8	8–12	0	–4
Heat-treated steel 42 CrMo 4 50 CrMo 4	1000–1400	8	6	6–8	6	–3	–4
Cast steel GE 200–GE 240	300–450	8	10	6–8	12	–3	–4
Grey cast iron GJL 100–GJL 150	1400–1800 HB	8	0	6–8	8–12	0 – +3	–4
Grey cast iron GJL 200–GJL 250	2000–2200 HB	8	0	6–8	6–12	0 – +3	–4
Brass Ms 63 (CuZn 37)	800–1200 HB	8	0	10	12	–	0
Al alloy 9–13 % Si	600–1000 HB	12	16	10	12	–	–4

Table 7.16 Input power of the three-phase asynchronous motors according to DIN 42673

<i>P</i> in kW	1,1	1,5	2,2	3	4	5,5	7,5	11	15	18,5	22	30
----------------	-----	-----	-----	---	---	-----	-----	----	----	------	----	----

7.11 Examples of calculation:

Example 1:

The task is to turn shafts made of S 275 JR, 100 Ø × 600 long between centres, in a roughing cut from 100 Ø down to 92 Ø.

Given:

Depth of cut

$$a_p = 4 \text{ mm}$$

Feed :

$$f = 1,0 \text{ mm}; \text{ tool cutting-edge angle } \kappa = 70^\circ$$

Angles for turning tool:

$$\gamma = 10^\circ; \alpha = 6^\circ; \lambda = -4^\circ$$

Cutting edge material: HM P20

Machine efficiency: $\eta_m = 0,7$

Sought for:

Major cutting force F_s , machine input power P and machining time t_h per shaft.

Approach:

1. Read allowable cutting speed from Table 7.8.

$$v_{c15} = 300 \text{ m/min}$$

2. Major cutting force F_c

- 2.1. Thickness of cut

$$h = f \cdot \sin \kappa = 1,0 \text{ mm} \cdot 0,939 = 0,94 \text{ mm}$$

- 2.2. Sectional area of chip

$$A = a_p \cdot f = 4 \text{ mm} \cdot 1 \text{ mm} = 4 \text{ mm}^2$$

- 2.3. Correction coefficients

$$K_\gamma = 1 - \frac{\gamma_{\text{tat}} - \gamma_0}{100} = 1 - \frac{10 - 6}{100} = 0,96$$

$$K_v = 1,0 \text{ for } v \text{ from } 80 \text{ to } 250 \text{ m/min}$$

$$K_{\text{st}} = 1,0 \text{ since external cylindrical turning}$$

$$K_{\text{ver}} = 1,3 \text{ wear factor}$$

- 2.4. Specific cutting force

$$k_c = \frac{(1 \text{ mm})^z}{h^z} \cdot k_{c1,1} \cdot K_\gamma \cdot K_v \cdot K_{\text{st}} \cdot K_{\text{ver}}$$

$$= \frac{(1 \text{ mm})^{0,17}}{0,94^{0,17}} \cdot 1780 \text{ N/mm}^2 \cdot 0,96 \cdot 1 \cdot 1 \cdot 1,3 = 2244,9 \text{ N/mm}^2$$

- 2.5. Major cutting force F_s

$$F_c = A \cdot k_c = 4 \text{ mm}^2 \cdot 2244,9 \text{ N/mm}^2 = 8979,7 \text{ N}$$

3. Machining time t_h

- 3.1. Total tool path

$$L = l_a + l + l_u = 2 \text{ mm} + 600 \text{ mm} + 2 \text{ mm} = 604 \text{ mm}$$

- 3.2. Speed calculation (related to initial diameter 100)

$$n = \frac{v_c \times 10^3 \text{ mm/m}}{d \times \pi} = \frac{135 \text{ m/min} \times 10^3 \text{ mm/m}}{100 \text{ mm} \times \pi} = 429,9$$

$$n = 429,9 \text{ min}^{-1}$$

$$n = 429,9 \text{ min}^{-1}$$

Since 429 is not a standard speed, select next closest speed from the standard series (Figure 7.47). For infinitely variable speed control, select $n_c = 430$.

$$n = 450 \text{ min}^{-1}$$

- 3.3. Machining time

$$t_h = \frac{L \times i}{f \times n} = \frac{604 \text{ mm} \times 1}{1,0 \text{ mm} \times 450 \text{ min}^{-1}} = 1,34 \text{ min/pce}$$

4. *Input power*

4.1. Determination of the real cutting speed from selected speed

$$n = 450$$

$$v_c = d \cdot \pi \cdot n = 0,1 \text{ m} \cdot \pi \cdot 450 \text{ min}^{-1} = 141,3 \text{ m/min}$$

4.2. Input power

$$P = \frac{F_c \times v_c}{60 \text{ s/min} \times 10^3 \text{ W/kW} \times h_M} = \frac{8979,7 \text{ N} \times 141,3 \text{ m/min}}{60 \text{ s/min} \times 10^3 \text{ W/kW} \times 0,7} = 30,2 \text{ kW}$$

Example 2

What is the maximal depth of cut feasible on a lathe with $P = 18,5 \text{ kW}$ input power, if shape roughness needs to be $63 \mu\text{m}$, operating under the assumption of the following data below?

Given:

Material:	E 295
Peak radius of the turning tool:	$r = 1,5 \text{ mm}$
Tool cutting-edge angle:	$\kappa = 90^\circ$
Angles for turning tool:	$\gamma = 12^\circ, \alpha = 6^\circ, \lambda = -4^\circ$
Tool material:	HM P20
Machine efficiency:	$\eta_m = 0,7$

Sought for:

1. Feed to be selected
2. Max. depth of cut

Approach:

1. Select feed

The feed can be taken from Table 7.2, as a function of the peak radius of the turning tool and required surface roughness of $63 \mu\text{m}$. The value we read in the table is $f = 0.87 \text{ mm}$. However, because 0.87 is not a standard feed, we select the next lower standard feed. If we were to select a greater feed, then the surface roughness requirement would not be fulfilled. The series of standard feeds can be seen in Table 7.8. In this case, it is $f = 0.63 \text{ mm}$.

2. *Maximal allowable depth of cut at given input power.*

2.1. Thickness of cut

$$h = f \cdot \sin \kappa = 0,63 \text{ mm} \cdot 1 = 0,63 \text{ mm}$$

2.2. Cutting speed

Read from Table 15 .

$$v_{c15} = 190 \text{ m/min for } f = 0,63 \text{ mm}$$

2.3. Correction coefficients

$$K_\gamma = 1 - \frac{\gamma_{\text{tat}} - \gamma_0}{100} = 1 - \frac{12 - 6}{100} = 0,94$$

$$K_v = 1; K_{st} = 1; K_{\text{ver}} = 1,3$$

2.4. Specific cutting force

$$k_{c1,1} = 1990 \text{ N/mm}^2 \text{ and take } z = 0,26 \text{ from Table 1}$$

$$k_c = \frac{(1 \text{ mm})^z}{h^z} \cdot k_{s1,1} \cdot K_\gamma \cdot K_v \cdot K_{st} \cdot K_{\text{ver}}$$

2.5. Convert equation for P to depth of cut

$$P = \frac{F_c \times v_c}{60 \times 10^3 \times h_M} = \frac{\overbrace{a_p \times f \times k_c}^{F_c} \times v_c}{60 \times 10^3 \times h_M}$$

$$a_p = \frac{60 \times 10^3 \times h_M \times P}{f \times k_c \times v_c} = \frac{60 \text{ s/min} \times 10^3 \text{ W/kW} \times 0,7 \times 18,5 \text{ kW}}{0,63 \text{ mm} \times 2742,2 \text{ N/mm}^2 \times 190 \text{ m/min}}$$

$$a_{p_{\max}} = \underline{\underline{2,36 \text{ mm}}}$$

8 Planing and slotting

8.1 Definition

Planing is a cutting technology in which the workpiece is machined in slices with a single blade tool, the planing tool.

Planing can be understood as a turning procedure that can be performed with an infinitely large diameter; that is, the cutting motion moves along a straight line.

8.2 Planing- and slotting methods

8.2.1 Shaping

During shaping, cutting and infeed motions are carried out by the tool, while the feed motion is performed by the worktable. Maximal shaping length (as a rule less than 1 m) is determined by the maximum stroke of the shaping machine (Figure 8.1).

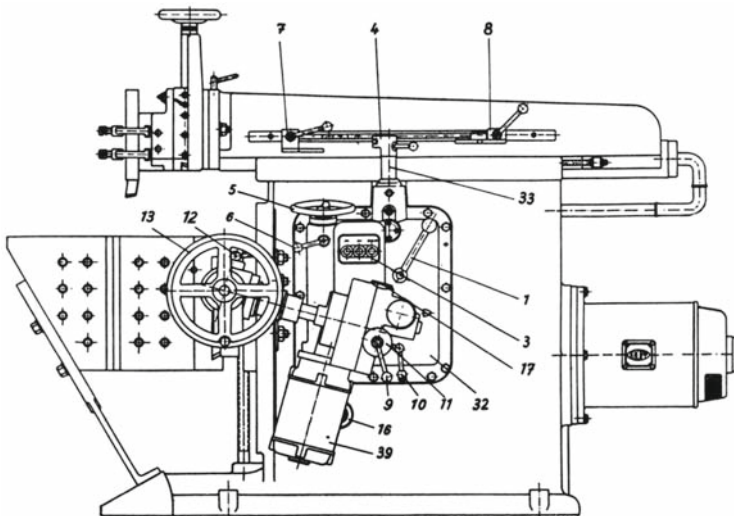


Figure 8.1
Hydraulically driven shaping machine with clamped planing tool

8.2.2 Slotting

Slotting is a variant of planing in which the single blade tool (Figure 8.2) carries out the cutting motion vertically, and the workpiece performs the infeed motion.

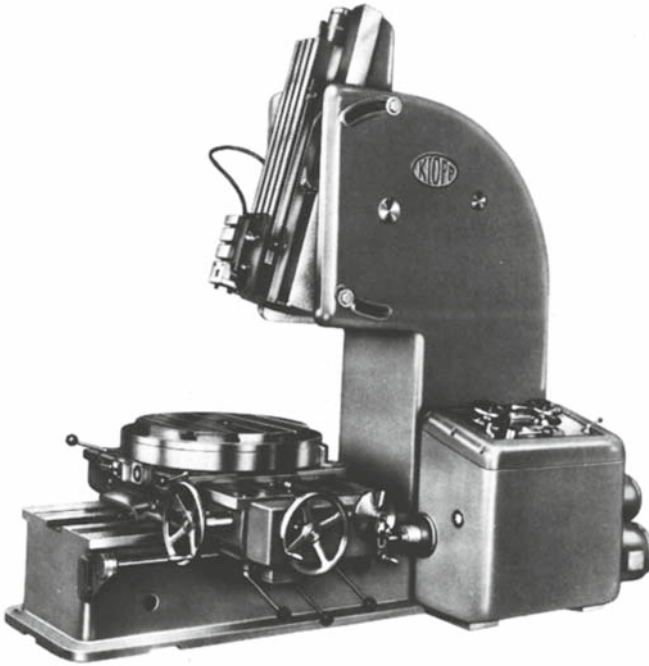


Figure 8.2
Slotting machine (*photo by Klopp-Werke Solingen*)

8.3 Application of the techniques

8.3.1 Shaping

is used for planing of plates and moldings with straight-lined boundaries for tool- and die-making and mechanical engineering. Copying attachments (compare Chapter 7.2.6.) can be used to generate sculptured surfaces strip by strip.

8.3.2 Slotting (vertical planing)

is applied to manufacture inner contours in tool elements and wheels, such as (Figure 8.2) keyways in holes of toothed gears. It is also possible to use the slotting technique to machine breakthroughs in blanking dies.

8.4 Accuracy values achievable with planing

The accuracy values that can be achieved with planing range from IT 7 to IT 8.

8.5 Determination of force- and power

8.5.1 Calculation of force

$$F_c = \frac{(1 \text{ mm})^z}{h^z} \times k_{c1,1} \times b \times h \times K_\gamma \times K_v \times K_{ver} \times K_{st}$$

F_c	in N	major cutting force
h	in mm	thickness of cut
z		material exponent
$k_{c1,1}$	in N/mm ²	specific cutting force for $h = b = 1$ mm
b	in mm	width of cut
K_γ		correction factor for rake angle
K_{ver}		wear factor (depends on the tool state) $K_{ver} = 1, 1-1,5$
K_v		correction factor for cutting speed $K_v = 1, 1$ with high speed steel tools $K_v = 1, 0$ with cemented carbide tools
K_{st}		correction factor for chip compression $K_{st} = 1, 1$

$$K_\gamma = 1 - \frac{\gamma_{tat} - \gamma_0}{100}$$

$\gamma_0 = 6^\circ$ for steel
 $\gamma_0 = 2^\circ$ for grey cast iron
 γ_{tat} = rake angle for the planing tool

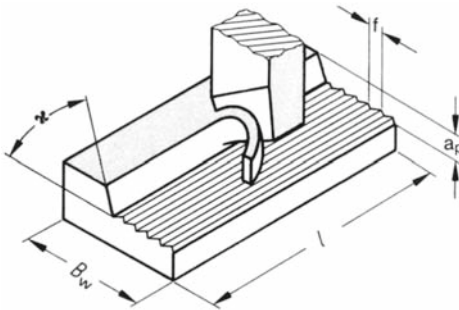


Figure 8.3
 Cutting parameters for planing
 l workpiece length, B_w workpiece width,
 f feed, a_p depth of cut, ι tool cutting-edge
 angle

8.5.2 Machine input power for shaping machines

$$P = \frac{F_c \times v_c}{60 \text{ s/min} \times 10^3 \text{ W/kW} \times \eta_M}$$

P in kW	machine input power
F_c in N	major cutting force
v_c in m/min	cutting speed in the working stroke, machine efficiency ($\eta_M = 0,6-0,7$)

8.5.3 Machine input power for parallel planing machines

In parallel planing machines, it is necessary to consider frictional and acceleration forces. As a function of reverse speed, approach length and table- and workpiece weight, the machine has to be dimensioned according to:

$$P_r = \frac{v_r \cdot m_{\text{ges}}}{60 \text{ s/min}} \left(\mu \cdot g + \frac{v_r}{60 \text{ s/min} \times t_a} \right) \frac{1}{h_M} \cdot \frac{1}{10^3 \text{ W/kW}}$$

P_r	in kW	power for return
m_{ges}	in kg	= $m_{\text{Tisch}} + m_{\text{Werkstück}}$
m_{Tisch}	in kg	table weight
$m_{\text{Werkstück}}$	in kg	workpiece weight
μ		frictional coefficient for table/ guidance $\approx 0,1$
g		acceleration due to gravity = $9,81 \text{ m/s}^2$
v_r	in m/min	return speed
t_a	in s	acceleration time ($t_a \cong 1 \text{ s}$)

or

$$P_v = [F_c + \mu(F_{\text{Tisch}} + F_{\text{Werkstück}})] \times \frac{v_c}{60 \text{ s/min}} \times \frac{1}{h_M} \times \frac{1}{10^3 \text{ W/kW}}$$

P_v	in kW	power for forward motion (cut)
F_c		major cutting force
F_{Tisch}	in N	table weight
$F_{\text{Werkstück}}$	in N	workpiece weight

It is necessary to calculate both power values, P_r and P_v . For dimensioning, the higher one is considered.

8.6 Calculation of the machining time

8.6.1 Speeds in planing

In planing, we distinguish between 2 speeds

8.6.1.1 Forward speed or cutting speed v_c

Forward speed is understood as the speed at which the table of the parallel planing machine moves during the cutting stroke, during which the tool is engaged.

In shaping machines, it is the speed at which the tool moves in the cutting stroke (forward stroke). This forward speed corresponds to the cutting speed that is to be taken from reference tables.

8.6.1.2 Reverse speed v_r

is the speed at which the table of the parallel planing machine or the ram of the shaping machine returns to its original position.

As a rule, the reverse speed is greater than the forward speed, since it is a loss variable as far as working progress is concerned.

Consequently, one calculates an average velocity v_m

$$v_m = \frac{2 \cdot v_c \cdot v_r}{v_c + v_r}$$

v_m	in m/min	average velocity
v_c	in m/min	forward stroke speed = cutting speed (operative cutting speed)
v_r	in m/min	reverse speed (return stroke)

from both speeds for determination of time. Reverse speed can be taken from machine data. If a difference exists between maximal and average reverse speed, the average reverse speed should be used.

8.6.2 Number of strokes per unit of time

The number of forward and return strokes that can be achieved in a period of time can be calculated as follows:

$$n_L = \frac{v_m \times 10^3 \text{ mm/m}}{2 \times L}$$

n_L	in min^{-1}	number of forward and return strokes
v_m	in m/min	average velocity
L	in mm	stroke length

8.6.3 Length- and width values that are considered in time calculations

The length of the total stroke (Figure 8.4) results from the lengths of workpiece, approach and overrun.

$$L = l_a + l + l_u$$

L	in mm	stroke length
l_a	in mm	tool approach
l	in mm	length of workpiece blank
l_u	in mm	tool overrun

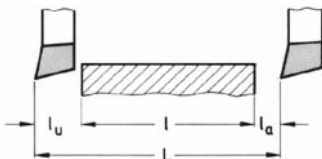


Figure 8.4
Length L in planing

8.6.3.1 Shaping

$l_a = 10 \text{ mm}$	Recommended values
$l_u = 5 \text{ mm}$	

Like length, it is also possible to determine the width covered per unit of time (Figure 8.5).

$$B = B_a + B + B_u$$

B	in mm	width to be inserted into the calculation
B_a	in mm	tool approach
B_w	in mm	width of workpiece blank
B_u	in mm	tool overrun

$$B_a = B_u = 4,0 \text{ mm}$$

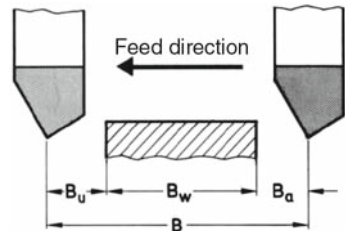


Figure 8.5
Width B in planing

8.6.4 Machining time for planing

$$T_h = \frac{B \cdot i}{f \cdot n_L} = \frac{2 \cdot B \cdot L \cdot i}{v_m \cdot f \cdot 10^3 \text{ mm/m}}$$

t_h	in min	machining time
B	in mm	width to be inserted into calculation
L	in mm	stroke length
v_m	in m/min	average velocity
f	in mm	feed per forward and return stroke
i		number of passes
n_L	in min^{-1}	number of forward and return strokes

The number of passes can be calculated from machining allowance a_{ges} and depth of cut a :

$$i = \frac{a_{ges}}{a_p}$$

i	number of passes, round up to an integer
a_{ges}	in mm machining allowance
a_p	in mm depth of cut

8.7 Reference table

Table 8.1 Cutting speeds $v_{c 120}$ for planing

Material	Strength or hardness in N/mm ²	$v_{c 120}$ for cemented carbide tools				$v_{c 120}$ for high speed tools		
		Feed f in mm/ forward and return stroke						
		HM (cemented carbide)	0,5	1,0	1,6	0,5	1,0	1,6
S 275 JR C 15–C 22	400–500	P 40	60	48	40	28	23	20
E 295–E 335 C 35–C 45	500–800	P 40	55	45	38	21	17	15
E 360 C 60	750–900	P 40	40	35	30	14	11	10
GE 240–GE 260	450–520	P 40	45	35	30	15	12	10
GJL 100–GJL 150	1400–1900 HB	K 20	50	40	30	25	18	14
GJL 200–GJL 250	2000–2400 HB	K 20	55	45	35	32	26	24

8.8 Example of calculation

The task is to plane steel plates made of E 295, 2700mm length, 850 mm width, in a roughing cut.

Given:

Depth of cut: $a_p = 10$ mm,
 Feed: $f = 1,6$ mm/ forward and return stroke
 Tool cutting-edge angle: $\iota = 60^\circ$,
 Rake angle: $\gamma = 10^\circ$,
 Tool material: High speed steel
 $\eta_M = 0,65$, reverse speed of the planer platen $v_r = 60$ m/min

Sought for:

Major cutting force, machine input power, machining time

Approach:

- From Tab. 8.1, $v = 15$ m/min was chosen
- Major cutting force

$$k_{c1,1} = 1990 \text{ N/mm}^2 \quad z = 0,26 \text{ from Tab.1.1}$$

$$h = f \cdot \sin \iota = 1,6 \text{ mm} \cdot 0,866 = 1,38 \text{ mm}$$

$$b = \frac{a_p}{\sin \iota} = \frac{10 \text{ mm}}{0,866} = 11,54 \text{ mm}$$

$$K_\gamma = 1 - \frac{\gamma_{\text{lat}} - \gamma_0}{100} = 1 - \frac{10^\circ - 6^\circ}{100} = 0,96$$

$$K_v = 1,1; \quad K_{\text{ver}} = 1,3; \quad K_{\text{st}} = 1,1$$

$$\begin{aligned} F_c &= \frac{(1 \text{ mm})^2}{h^z} \cdot k_{\text{cl},1} \cdot b \cdot h \cdot K_\gamma \cdot K_v \cdot K_{\text{ver}} \cdot K_{\text{st}} \\ &= \frac{(1 \text{ mm})^2}{1,38^{0,26}} \cdot 1990 \cdot 11,54 \cdot 1,38 \cdot 0,96 \cdot 1,1 \cdot 1,3 \cdot 1,1 \end{aligned}$$

$$F_c = 44011,7 \text{ N} = \underline{\underline{44,01 \text{ kN}}}$$

3. *Machine input power (without frictional- and acceleration forces)*

$$P = \frac{F_c \times v_c}{60 \text{ s/min} \times 10^3 \text{ W/kW} \times h_M} = \frac{44011,7 \text{ N} \times 15 \text{ m/min}}{60 \text{ s/min} \times 10^3 \text{ W/kW} \times 0,65}$$

$$P = 16,93 \text{ kW}$$

4. *Machining time*

4.1 *Average velocity*

$$v_m = \frac{2 \times v_c \times v_r}{v_c \times v_r} = \frac{2 \times 15 \text{ m/min} \times 60 \text{ m/min}}{(15 + 60) \text{ m/min}} = 24 \text{ m/min}$$

4.2 *Stroke length*

$$L = l_a + l + l_u$$

$$l_a \approx 10 \text{ mm/m} \cdot \text{min} \cdot 15 \text{ m/min} = 150 \text{ mm}$$

$$l_u \approx 0,5 \cdot l_a = 75 \text{ mm}$$

$$L = 150 \text{ mm} + 2700 + 75 \text{ mm} = 2925 \text{ mm}$$

4.3 *Width to be put into equation*

$$B = B_a + B_w + B_u$$

$$B_a = B_u = 4,0 \text{ mm}$$

$$B = 4 \text{ mm} + 850 \text{ mm} + 4,0 \text{ mm} = 858 \text{ mm}$$

4.4 *Machining time*

$$t_h = \frac{2 \times B \times L \times i}{v_m \times f \times 10^3 \text{ mm/m}} = \frac{2 \times 858 \text{ mm} \times 2925 \text{ mm} \times 1}{24 \text{ m/min} \times 1,6 \text{ mm} \times 10^3 \text{ mm/m}}$$

$$t_h = 130,71 \text{ min}$$

9 Drilling

9.1 Definition

Drilling is a cutting procedure designed to generate holes predominantly with a two-flute tool, the twist drill. When drilling on the drilling machine, the tool carries out the feed- and the cutting motions. If the hole is machined on a turning- or automatic lathe, then the workpiece performs the cutting motion.

9.2 Drilling methods

9.2.1 Centre drilling

The twist drill penetrates the solid material, which is still unmachined, in order to generate a through hole or blind hole (Figure 9.1).

This procedure consists of three stages.

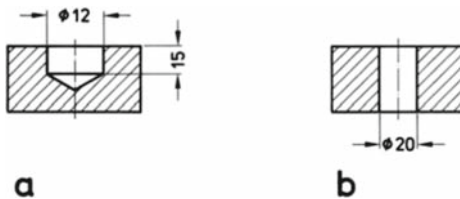


Figure 9.1
Hole types
a blind hole, b through hole

To begin the hole: The drill point chisel edge rests on the workpiece and the conical tip penetrates the material. During this phase, the sectional area of chip changes as long as the drill is fully in the cut. Feed force and torque increase.

Full cut phase : In this phase, the sectional area of chip remains constant. Cutting forces increase with increasing drilling depth, as a result of restricted chip removal and, consequently, friction.

Passage of the drill point: This third phase only appears in through holes. If, in these holes, the drill point penetrates the material, then the drill's chisel edge is no longer supported in axial direction. The drilling machine column springs off, which results in pre-stress that is suddenly resolved and has the effect of an amplified feed rate. This causes the primary cutting edges to dig in and frequently causes the drill to break off.

9.2.2 Drilling out – boring (Figure 9.2)

If a large hole is to be made, then it is necessary to carry out several drilling operations. The diameter limit, above which it is necessary to drill out, is a function of

machine input power
and the centering capability of the twist drill.

When a drilling machine is available, input power is a constant. This means that the allowable drill diameter results from the material to be drilled and the associated feed.

When drilling out a hole that has been pre-drilled with a twist drill, the chisel edge can no longer cut. For this reason, chisel edge pressure need not be considered.

Consequently, feed force and thus the input power necessary for drilling out diminishes.

Twist drills with a great diameter, due to their large chisel edge, tend to run out of the centre when starting the hole. This is why large holes are pre-drilled with a twist drill with a smaller diameter. Here, as a rule of thumb, the diameter of the first drill must not be greater than the final drill's core thickness. When drilling out, the twist drills can no longer back up with the chisel edge. For this reason, the cutting edges frequently dig in or chatter, which results, in turn, in inexact and dimensionally incorrect holes.

Consequently, for drilling out, it is preferable to use multi-edged helical counterbores that work much more quietly.

The diameter of the first drill (pre-drilling diameter) for a special hole depends on the boring tool.

The pre-drilling diameter can be calculated with the equation below.

$$d = c \cdot D$$

d in mm pre-drilling diameter
 D in mm finish boring diameter
 c tool constant

The material constant c is a function of the boring tool type. Three average values are shown in Table 9.1.

Table 9.1 Diameter increments for boring

Boring tool	Tool constant c
Twist drill	0,3
Counterbore with spiral flutes	0,75
Arbour-type counterbore	0,85

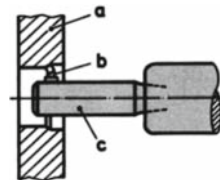


Figure 9.2
 Boring bar with boring bit
 a workpiece, b boring bit, c boring bar

When boring on a turning lathe or boring mill, the pre-drilled hole is cut with a turning tool (Figure 9.2). On drilling machines or boring mills, special tools are also used, such as single- or two-edged, dimensionally readjustable tool heads, which can be set on specially customised tool shanks and are replaceable (see also Chapter Drilling tools).

9.2.3 Counterboring

In counterboring, partial surfaces in holes are machined with the face of a multi-edged tool, the so-called counterbore or countersink. The shape of the counterbore corresponds to the workpiece contour.

In stepped holes (Figure 9.3), the step is generated with a counterbore or countersink.



Figure 9.3
Stepped holes
a created with counterbore (cylindrical tool),
b created with countersink (conical tool)

9.2.4 Reaming

Reaming is a cutting method in which pre-drilled or counterbored holes are cut to fit a particular dimension with a multi-edged tool, with the edges located around the circumference. Reamed holes are not only of high dimensional accuracy, but have also a smooth and clean surface. The tool used for this operation is the reamer.

9.2.5 Thread cutting with taps

In thread cutting, the tool equipped with thread profile, the tap, is turned into the hole. Since the tool’s cutting flutes have the pitch of the thread to be cut, the tap, after having started the cut, pulls itself into the hole.

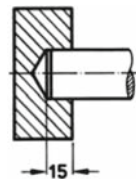
9.3 Generation and purpose of holes

9.3.1 Blind holes (Figure 9.4)

9.3.1.1 Purpose

to retain bolts or axes

Figure 9.4
Blind hole



9.3.1.2 Generation

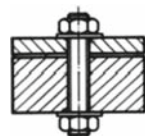
Blind holes are centre drilled with the twist drill. For large diameters, they are pre-drilled with a twist drill and drilled out with twist drill or helical counterbore.

9.3.2 Through hole (Figure 9.5)

9.3.2.1 Purpose

to join two or more elements

Figure 9.5
Through hole



9.3.2.2 Generation

Through holes are centre drilled with the twist drill, or, for large diameters, pre-drilled with the twist drill and drilled out with the twist drill or the helical counterbore.

9.3.3 Tapered holes (Figure 9.6)

9.3.3.1 Purpose

To mount conical elements, such as taper pins, that define the mutual location of two plates. Tapered holes are also needed to mount tools with taper shanks (for example, twist drills, cutter arbours).

9.3.3.2 Generation

Tapered holes are tolerance holes. They are pre-drilled with a twist drill and then reamed with a tapered reamer. Tool clamping holes are additionally ground.

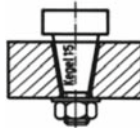


Figure 9.6
Tapered hole

9.3.4 Counterbores (Figure 9.7)

9.3.4.1 Purpose

to mount bolts and rivets that must not protrude.

9.3.4.2 Generation

They are pre-drilled with a twist drill and counterbored with a counterbore (for cylindrical shape) or otherwise shaped with countersink (for tapered and other shapes).

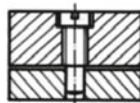


Figure 9.7
Counterbore

9.3.5 Tapped hole (Figure 9.8)

9.3.5.1 Purpose

These holes are intended to be used in attaching elements, for instance, in mounting a plate on a press die.

9.3.5.2 Generation

After pre-drilling with a twist drill, the thread is generated with taps.

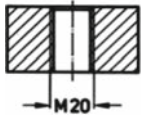


Figure 9.8
Tapped hole

9.4 Accuracies feasible with drilling

Drilling with twist drill is a kind of roughing. Higher accuracies to size and better surface qualities can be achieved by reaming, counterboring, fine hole drilling and boring. Table 9.2 shows the relationship between drilling methods and feasible accuracies to size or surface quality.

Table 9.2 Feasible tolerances and surface qualities for various drilling methods (from [24], page 13)

Technique	ISO tolerance (Average values) IT	Peak-to-valley height R_t in μm	Surface quality
Centre drilling	12	80	Roughing
Drilling out with helical counterbores	11	20	Finishing
Counterboring/ countersinking with flat counterbores and countersinks	9	12	Finishing
Reaming	7	8	Fine finishing
Boring with boring tool or multi-edged boring head	7	8	Fine finishing
Boring with cemented carbide cutting edges and very small sectional area of chip	7	4	Fine finishing

Table 111 (Appendix) shows the relationship between the ISO qualities and the dimensional tolerances

9.5 Calculation of forces, torque and power

The cutting parameters for drilling can be derived from the basics laid down in Chapter 2. Apart from the intrinsic cutting force that applies at the cutting edges of the drilling tool, frictional forces occurring between the phases of the drilling tool and the wall of the hole also have an effect.

Since the power equation is a general one and thus is also valid for all drilling methods, it is introduced at the beginning as a central equation.

Machine input power is $P = M \cdot \omega$, and through conversion we find:

$$P = \frac{M \cdot n}{9,55 \text{ s/min} \cdot 10^3 \text{ W/kW} \cdot \eta_M}$$

ω	in s^{-1}	angular velocity
P	in kW	input power
M	in Nm	torque
n	in min^{-1}	speed (rpm)
η_M		efficiency of the drilling machine (0,7 to 0,9)
9,55	in s/min	constant from $(2 \cdot \pi \cdot n/60 \text{ s/min})$

9.5.1 Centre drilling (Figure 9.9)

9.5.1.1 Feed per cutting edge f_z

$$f_z = \frac{f}{z_E}$$

f_z	in mm	feed per cutting edge
f	in mm	feed per revolution
z_E		number of cutting edges ($z_E = 2$ for twist drill)

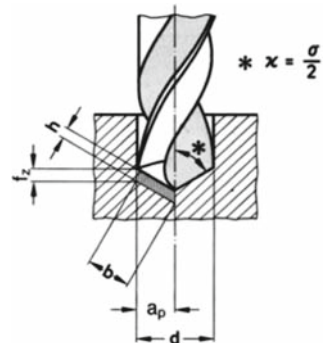


Figure 9.9
Cutting parameters for centre drilling

9.5.1.2 Thickness of cut hw

$$h = f_z \cdot \sin \iota$$

$$\iota = \frac{\sigma}{2}$$

h	in mm	thickness of cut
ι	in $^\circ$	tool cutting-edge angle = $\frac{\sigma}{2}$
σ	in $^\circ$	point angle of the twist drills

9.5.1.3 Width of cut b

$$b = \frac{d}{2 \cdot \sin \iota}$$

- b in mm width of cut
- d in mm hole diameter
- a_p in mm depth of cut (width of cut)

9.5.1.4 Sectional area of chip A

$$A = b \cdot h = \frac{d \cdot f_z}{2}$$

- A in mm² sectional area of chip
- d in mm drill diameter
- f_z in mm feed per cutting edge

9.5.1.5 Specific cutting force

$$k_{Ch} = \frac{(1\text{mm})^z}{h^z} \cdot k_{c1,1} = \frac{(1\text{mm})^z}{(f_z \cdot \sin \iota)^z} \cdot k_{c1,1}$$

Taking into account the correction factors, we then obtain:

$$k_c = \frac{(1\text{mm})^z}{(f_z \cdot \sin \iota)^z} \cdot k_{c1,1} \cdot K_v \cdot K_{st} \cdot K_{ver}$$

- k_c in N/mm² specific cutting force
- k_{ch} in N/mm² specific cutting force, related to h^{-z}
- $k_{c1,1}$ in N/mm² specific cutting force for $h = b = 1$ mm
- f_z in mm feed per cutting edge
- z exponent (material constant)
- K_v correction factor for cutting speed
 $K_v = 1,0$ for cemented carbide $K_v = 1,15$ for high speed steel
- $K_{st} = 1,2$ correction factor for compression of the chip
- $K_{ver} = 1,3$ correction factor, taking into account tool wear

9.5.1.6 Major cutting force per cutting edge F_{cz}

$$F_{cz} = a_p \cdot f_z \cdot k_c = b \cdot h \cdot k_c = \frac{d \cdot f_z}{2} \cdot k_c$$

$$F_{cz} = \frac{d \cdot f_z}{2} \cdot k_c$$

- F_{cz} in N major cutting force per cutting edge
- d in mm hole diameter
- f_z in mm feed per cutting edge
- k_c in N/mm² specific cutting force

9.5.1.7 Feed force F_f

$$F_f = z_E \cdot F_{cz} \cdot \sin \iota$$

F_f in N feed force
 z_E number of cutting edges

9.5.1.8 Torque M

$$M = F_c \cdot \frac{d}{4}$$

$$F_s = F_{cz} \cdot z_E$$

$$M = \frac{d^2}{8} \cdot f_z \cdot z_E \cdot k_c \cdot \frac{1}{10^3 \text{ mm/m}}$$

$$f = z_E \cdot f_z$$

M in Nm torque
 d in mm hole diameter
 f_z in mm feed per cutting edge
 z_E number of cutting edges
 f in mm feed per revolution
 k_c in N/mm² specific cutting force
 F_c in N major cutting force

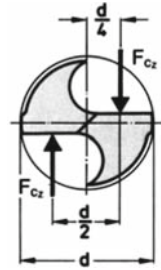


Figure 9.10
 Line of action of the major cutting force with a distance $d/4$ to the drill axis

For torque calculation, it is assumed that the major cutting force applies in the middle of the primary cutting edge. This results in a $d/4$ distance from force line of action to the drill axis.

9.5.2 Drilling out (Figure 9.11)

In principle, the same equations are valid as under 9.5.1. For this reason, in this chapter, we will only discuss equations that are different from those in Chapter 5.5.1.

9.5.2.1 Width of cut b

$$b = \frac{D - d}{2 \cdot \sin \iota}$$

$$a_p = \frac{D - d}{2}$$

b in mm width of cut
 D in mm diameter of the finished hole
 d in mm diameter of the pre-drilled hole
 ι tool cutting-edge angle = $\sigma/2$
 a_p in mm depth of cut

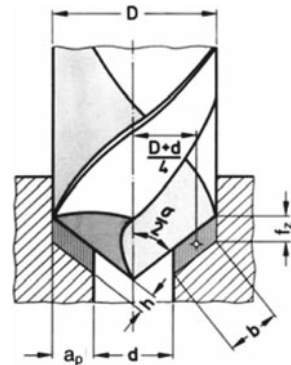


Figure 9.11
 Cutting parameters for drilling out

9.5.2.2 Thickness of cut h

$$h = f_z \cdot \sin \iota \quad \iota = \frac{\sigma}{2}$$

f_z in mm feed per cutting edge

9.5.2.3 Major cutting force per cutting edge

$$F_{c_z} = \frac{D-d}{2} \cdot f_z \cdot k_c$$

F_{c_z} in N major cutting force per cutting edge
 k_c specific cutting force
 (as under 9.5.1.5.)

9.5.2.4 Torque

$$M = z_E \cdot F_{c_{zE}} \cdot \frac{D+d}{4}$$

$$M = \frac{D^2 - d^2}{8} \cdot z_E \cdot f_z \cdot k_c \cdot \frac{1}{10^3 \text{ mm/m}}$$

M in Nm torque
 D in mm diameter of the finished hole
 d in mm diameter of the pre-drilled hole
 f_z in mm feed per cutting edge
 k_c in N/mm² specific cutting force (as under 9.5.1.5)
 z_E number of cutting edges

9.5.3 Counterboring (Figure 9.12)

Spot facing - sinking

Here we have the same conditions as for drilling out. This is why, for the calculation of major cutting force

torque

and input power

we use the same approach as for drilling out. Deviations are listed below:

1. Number of cutting edges

As a rule, a counterbore includes many cutting edges. From this circumstance, we derive

$$f = z_E \cdot f_z$$

f in mm feed per revolution
 z_E number of cutting edges
 f_z in mm feed per cutting edge

2. Distance from a mean point of application of the force of a cutting edge to the workpiece axis.

Distance is:

$$\frac{D + d}{4}$$

3. In counterboring, there is $\iota = \frac{\sigma}{2} = 90^\circ$

From that, we conclude: $h = f_z \cdot \sin \iota$
 $\sin 90^\circ = 1$

Consequently, there is $h = f_z$

h in mm thickness of cut
 f_z in mm feed per cutting edge

Depth of cut a_p is: $a_p = \frac{D - d}{2}$

However, since $b = \frac{a_p}{\sin \iota}$, $\iota = 90^\circ$, there is

$$b = a_p$$

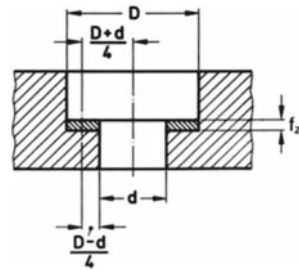


Figure 9.12
 Cutting parameters and distances for spot facing

9.5.3.1 Major cutting force per cutting edge

$$F_{cz} = \frac{D - d}{2} \cdot f_z \cdot k_c$$

D in mm counterbore diameter
 d in mm diameter of pre-drilled hole
 f_z in mm feed per cutting edge
 k_c in N/mm² specific cutting force (compare 9.5.1.5.)

9.5.3.2 Torque M

$$M = z_E \cdot F_{cz} \cdot \frac{D + d}{4}$$

$$M = \frac{D^2 - d^2}{8} \cdot z_E \cdot f_z \cdot k_c \cdot \frac{1}{10^3 \text{ mm/m}}$$

M in Nm torque
 z_E number of cutting edges

9.5.4 Reaming

In reaming, cutting forces are low, which means that the input power of machines suitable for drilling is always sufficient. This is also the explanation for why it does not make sense to calculate cutting force and torque here.

9.5.5 Thread cutting with taps

9.5.5.1 Torque

In thread cutting, the practitioner is more interested in knowing the torque than the force.

$$M = \frac{P^2 \cdot d \cdot k_c \cdot K}{C \cdot 10^3 \text{ mm/m}}$$

M in Nm torque
 P in mm pitch
 d in mm maximum diameter of the tool's cutting edge (thread inner diameter)
 C constant $C = 8$
 K tool constant

Factor K is a function of the number of taps that are part of a tap set. We distinguish between sets with two and three taps. If a thread is pre-cut and cut with only one tap, then this tap is called a “single tap”. For the single tap, factor $K = 1$.

For other K values see the Table below.

Table 9.3 K values for different taps

Number of taps per set	Tap no.	K values
1	1	1
2	1	0,8
	2	0,6
3	1	0,6
	2	0,3
	3	0,2

9.6 Calculation of machining time (machine time)

Analogously to turning, the machining time can be calculated based on the length of the hole, the number of holes, feed per revolution and speed.

$$t_h = \frac{L \cdot i}{f \cdot n}$$

t_h	in min	machining time
f	in mm	feed per revolution
L	in mm	total path of the drilling tool
n	in min^{-1}	speed
i		number of holes

Speed is calculated from the cutting speed equation shifted to the speed. The cutting speed can be taken from reference tables (Chapter 9.9.).

$$n = \frac{v_c \cdot 10^3 \text{ mm/m}}{d \cdot \pi}$$

n	in min^{-1}	speed
v_c	in m/min	cutting speed
d	in mm	drill diameter

The total path L that the drilling tool has travelled after switching on machine feed depends on the drilling method and the drilling tool used. The general equation valid for all drilling methods is:

$$L = l_a + l + l_u$$

L	in mm	total path of the drilling tool
l_a	in mm	pre-travel (approach)
l	in mm	length of the hole
l_u	in mm	overrun path

The pre-travel- and overrun paths differ from drilling method to drilling method.

9.6.1 Centre drilling

For the twist drill, pre-travel l_a (Figure 9.13) consists of 2 parameters

1. a safety distance of 1 mm
2. variable x

$$l_a = x + l$$

When manually approaching the drilling machine spindle to the workpiece, in order to avoid damage to the tool tip the drill is not set immediately onto the workpiece. Instead, a safe distance of approx. 1 mm between tool and workpiece is maintained.

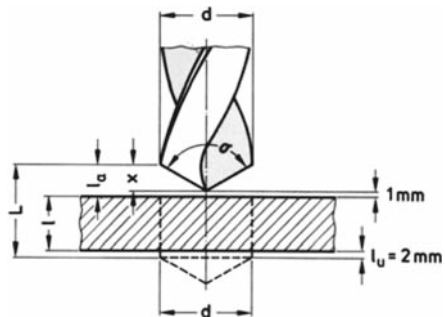


Figure 9.13
Pre-travel for centre drilling

Variable x (length of drill point) can be determined from diameter and the point angle of the twist drill.

$$x = \frac{d}{2 \cdot \tan \frac{\sigma}{2}}$$

- x in mm length of drill point
- d in mm drill diameter
- σ in $^\circ$ point angle of the drill

9.6.2 Drilling out with twist drill

For drilling out (Figure 9.14), the variable x can be determined from the diameter difference between the pre-drilling tool and the finish drilling tool and the halve point angle.

$$x = \frac{D - d}{2 \cdot \tan \frac{\sigma}{2}}$$

- x in mm distance (see Figure 9.14)
- D in mm finish drilling diameter
- d in mm pre-drilling diameter
- σ in $^\circ$ point angle

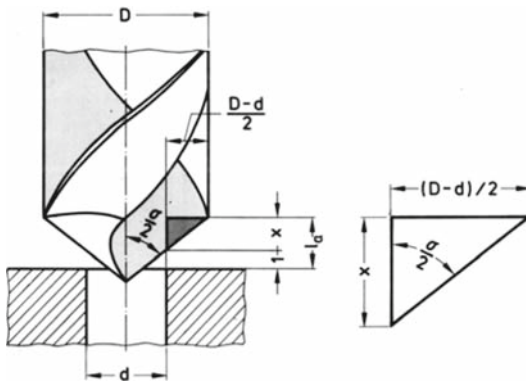


Figure 9.14
Pre-travel for drilling out with twist drill

9.6.3 Spot facing

For this method, pre-travel l_a is used.

$$l_a = \frac{D - d}{3}$$

- l_a in mm pre-travel
- D in mm diameter of the counterbore
- d in mm diameter of the pre-drilled hole

9.6.4 Thread cutting

In thread cutting, the pre-travel path depends on the pitch of the thread to be cut and the type of drill point sharpening. On average, we may assume l_a to be:

$$l_a = 3 P$$

P in mm pitch

As a rule, overrun l_u has a fixed value for drilling. In this textbook, we define it as

$$l_u = 2,0 \text{ mm}$$

for through holes.

In blind holes, $l_u = 0$

Table 9.4 below shows a summary of pre-travel- and overrun paths.

Table 9.4 Pre-travel l_a and overrun l_u [16]

Cutting procedure	Point angle	Pre-travel l_a		Overrun l_u
		centre drilling	in drilling out	
Drilling with twist drill	80°	$\frac{5}{8} \cdot d + 1$	$\frac{5}{8}(D - d) + 1$	Blind hole: 0
	118°	$d/3 + 1$	$\frac{D - d}{3} + 1$	
	130°	$d/4 + 1$	$\frac{D - d}{4} + 1$	Through hole: 2 mm
Counterbore (spot-facing)		$\frac{D - d}{3}$		0
Reaming		D		d
Thread cutting		$3 \cdot P$		–

For drill type N used for steel, point angle $\sigma = 118^\circ$, we obtain the following total path L (rounded values):

Centre drilling

Blind hole:

$$L = \frac{d}{3} + 1 + l$$

Through hole:

$$L = \frac{d}{3} + 3 + l$$

Drilling out with twist drill

Through hole:

$$L = l + 3 + \frac{D - d}{3}$$

9.7 Drilling tools

9.7.1 Twist drill

9.7.1.1 Structure of the twist drill

The twist drill (Figure 9.15) consists of the body with the drill point and the shank.

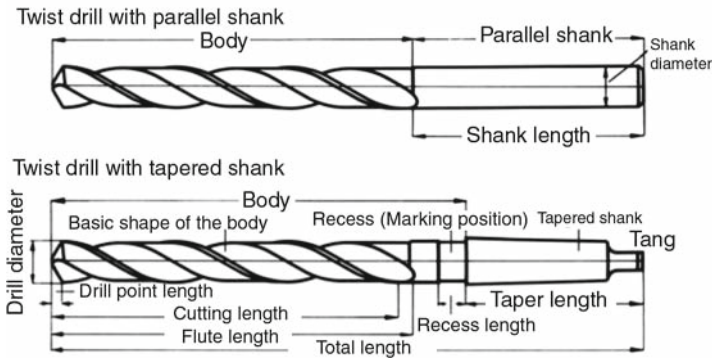


Figure 9.15
Elements of the twist drill

While the drill point performs the actual metal removal, the body with the flute is engineered to remove the chips. The shank has to hold the drill in the drill spindle of the drilling machine.

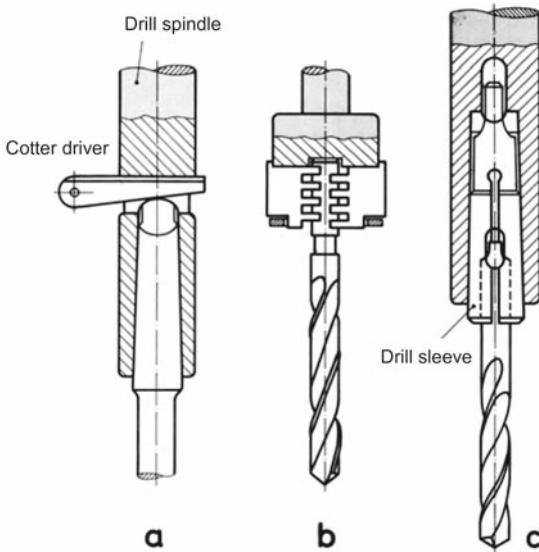


Figure 9.16
Variants of clamp twist drills
a) drill with Morse taper in drill spindle,
b) drill with parallel shank in the chuck,
c) drill with parallel shank and tang in drill sleeve

Twist drills are subdivided into drills with parallel and tapered shank.

The twist drill with taper shank (Figure 9.16) is characterised by driving through static friction on the taper walls.

The tang is only designed to drill out the drill spindle or the reducing bush.

The twist drill with parallel shank is clamped in the collet (Figure 9.16b). For this reason it normally does not need any tang.

Drills with parallel shank and tang are only used if the torque strongly vibrates, for example when drilling out a pre-drilled hole, in which the drill slightly hooks in. In this case, the tang has to transform the drill torque in a positive way.

Figure 9.16c shows a twist drill with parallel shank and tang. The drill is put into the slotted drill sleeve and pushed – together with the drill sleeve – into the taper hole of the drill spindle.

The basic shape of the body (Figure 9.17) is created by 2 helical grooves and the

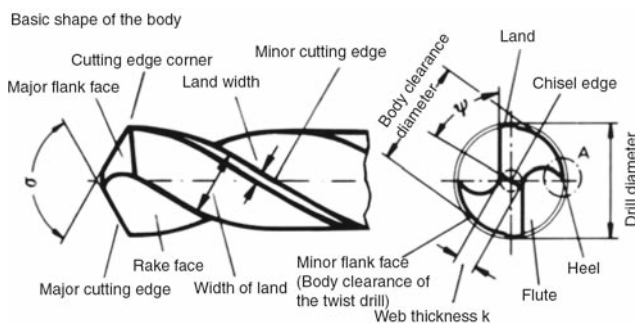


Figure 9.17 Twist drill body, σ = point angle, ψ = chisel edge angle

tapered drill point.

The core or web of the drill stalls between the helical flutes. The core with a tapered contour from the top toward the shank (Figure 9.18) makes the drill stable. At the

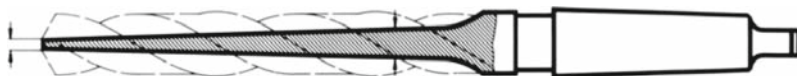


Figure 9.18 Core or web of a twist drill

Table 9.5 Core thickness values of the twist drill type N (excerpt from standard DIN 1414)

Drill \varnothing in mm	10	16	25	40
Core thickness in mm	1,8	2,5	3,5	5,2

drill point, core thickness K corresponds to the width of the chisel edge.

At the circumference, the twist drill is relieved by milling. Only the narrow land has the full drill diameter. The dimensions of the land widths are listed in Table 9.6.

Table 9.6 Land width values of twist drills (excerpt from standard DIN 1414)

Drill \varnothing in mm	10	16	25	40
Land width in mm	0,8	1,5	1,7	2,5

To minimise friction between the land and the hole wall, twist drills are tapered toward the shank. The value of diameter tapering is defined in the standard DIN 1414 with 0,02–0,08 mm to a flute length of 100 mm as a function of the drill diameter.

9.7.1.2 Cutting edge geometry of the twist drill

The twist drill is self-centering due to the taper-like sharpening of the drill point. The primary cutting edges have a wedge geometry (Figure 9.19). In principle, it is possible to define the angles for the twist drill’s cutting edges in the same way as for the turning tool.

The rake angle γ is measured in the reference plane of the cutting edge (Figure 2.2). However, the rake angle is not constant, but changes along the primary cutting edge and increases toward the drill point. For this reason, the rake angle is measured at the cutting edge corner and called a tool side rake γ_x (formerly named as helix angle). From the same point, the cutting edge corner, we also define tool side clearance α_x and tool orthogonal wedge angle β_x .

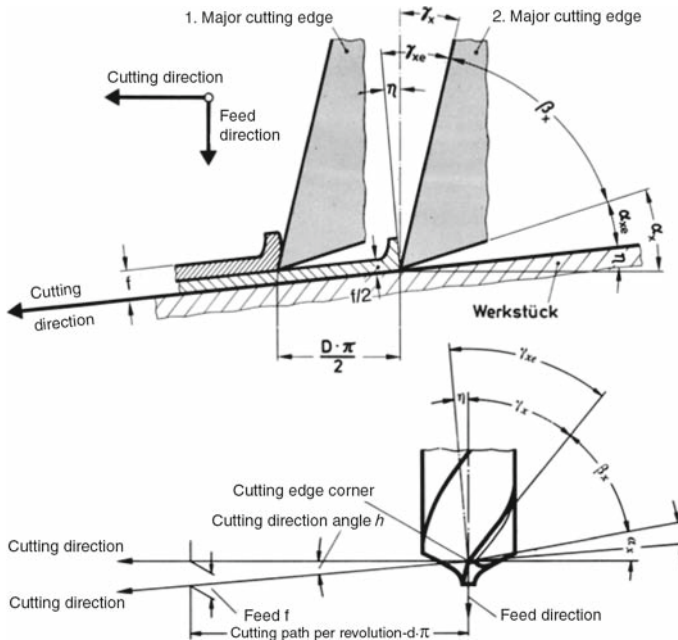


Figure 9.19

Angles for the cutting edges of the twist drill according to DIN 1412 and DIN 6581

α_x = tool side clearance, α_{xe} = effective tool side clearance, β_x = tool orthogonal wedge angle, γ_{xe} = effective tool side rake, γ_x = tool side rake, η = angle of the effective direction of cut

Chisel edge angle ψ (Figure 9.17) is the angle between a primary cutting edge and the chisel edge. It ranges from 49° to 55° . The order of magnitude of the angles as a function of the drill diameter is elucidated in Table 9.7.

Table 9.7 The most essential angular values for twist drills with a point angle of 118° , type N.

Drill \varnothing in mm	Tool side clearance $\alpha_s \pm 1^\circ$	Tool side rake angle $\gamma_s \pm 3^\circ$	Chisel edge angle ψ	Point angle $\sigma \pm 3^\circ$
2,51 – 6,3	12	22	52	118
6,31 – 10	10	25	52	
> 10	8	30	55	

9.7.1.3 Twist drill types

Twist drills are subdivided into 3 basic tool types with the denomination N, H and W.

The ranges of application for the drill types are:

N – for **normal** steel- and cast iron materials

H – for **hard** materials, plastics and Mg alloys

W – for **soft** materials, Al alloys and pressed materials.

Special point angle- and tool side rakes are assigned to each drill type (Figure 9.20). An overview showing which drill type is to be used for which material appears in Table 9.8.

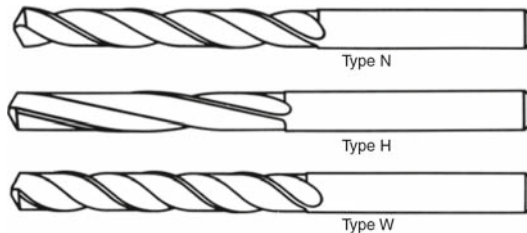


Figure 9.20
Twist drill types

Table 9.8 Drill types and their ranges of application

Tool type	Material	Strength N/mm ²	Tool side rake γ_x	Point angle $\pm 3^\circ$
N	Unalloyed steel for example C 10–C 35, Ck 10–Ck 35, S 275 JR	up to 700	20–30	118
	Unalloyed steel, alloyed steel for example C45, 34Cr4, 22NiCr14, 25CrMo5, 45S20, 20Mn5, 20MnMo4	> 700 up to 1000	20–30	130
	Grey cast iron GJL 150–GJL 400 malleable cast iron brass (CuZn 37) Al alloys with more than 11% Si			
	Alloyed steels for example 36CrNiMo4 stainless steels for example X 10Cr13 heat resistant steels for example X 210Cr12			
H	Magnesium alloys for exam- ple MgAl 6Zn3 soft plastics (thermo plastics) for example ultramide, polyamide, Mn-steels and brittle Ms		10–20	118
W	Copper, unalloyed lowgrade Al alloy Al- up to 10% Si-alloyed pressed materials, for example type 31 with phenolic resin		30–40	140

9.7.1.4 Morse taper of the twist drill

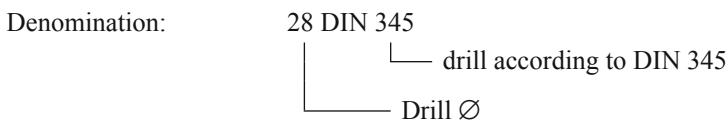
The table below shows the Morse tapers of the twist drills.

Table 9.9 Morse tapers of twist drills as a function of drill diameter

Diameter range in mm	3–14	14–23	23–31,75	32–50	51–76	77–100
Morse taper	1	2	3	4	5	6

9.7.1.5 Denomination of the twist drill

a) Twist drill with Morse taper DIN 345



b) Short twist drill with parallel shank DIN 338

Denomination: 6 DIN 338
 └─ drill according to DIN 338
 └─ Drill Ø

c) Twist drill with parallel shank, cutting edge made of cemented carbide DIN 8037

Denomination: 8 DIN 8037-K 10
 └─ cemented carbide name
 └─ drill according to DIN 8037
 └─ Drill Ø

Twist drill standards*with parallel shank*

extra short DIN 1897
 short DIN 338
 long DIN 340
 overlength DIN 1869

with taper shank (Morse taper)

extra short DIN 345
 short DIN 345/346
 overlength DIN 1870

with cutting edge (cemented carbide)
 DIN 8037, DIN 8038, DIN 8041

Solid carbide drills (metal ceramic drills), which allow cutting speed values up to $v_c = 500$ m/min, are being used more and more.

9.7.1.6 Cemented carbide-twist drills

Cemented carbide drills are advanced high-performance drilling tools. Solid carbide drills with three times the stiffness of high speed steels, high wear resistance and heat resistance, are run at cutting speeds up to 250 m/min in steel and cast iron, and up to 1000 m/min in aluminium alloys.

For the cutting of steel, coated cemented carbides are predominantly used. The coating, mostly with the finest grain cemented carbides, is deposited using the physical vapour deposition technique (PVD).

Cemented carbide drills are used for drilling depths up to $10 \times D$ (max. to $30 \times D$).

Other advantages are:

- drilling without pre-centering
- no chisel edge, resulting in low feed forces
- large chip spaces, consequently good chip removal
- highly exact drills generate tolerance values of IT7, making follow-up reaming unnecessary

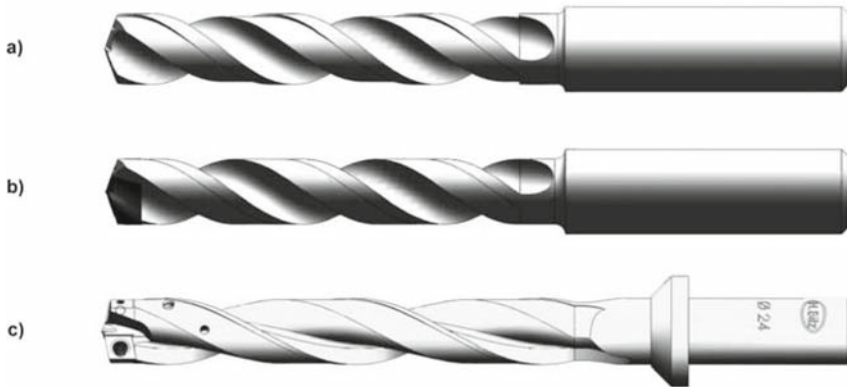


Figure 9.21

Cemented carbide twist drill

a) solid carbide twist drill b) drill with solid carbide head, c) drill with replaceable cutting inserts (photo by Hermann Bilz GmbH & Co KG, Esslingen, www.Hermann-Bilz.de)

Cemented carbide head drills with diameters of approximately 8 mm upward offer the above-mentioned properties at the drill point in combination with a tough basic body made of steel. Under less stable conditions of use, this combination guarantees higher safety against fracture. Because of their low consumption of cutting material, it is possible to produce drills like these partially somewhat more economically as well.

Drills with exchangeable cemented carbide-, high speed steel- or polycrystalline diamond cutting edges are used beginning from about 16 mm diameter. It is possible to optimally tip these tools for different applications with indexable inserts with the corresponding geometry and centre bits.

The advantages of these drills are:

- self-centering by a core cutting edge and two symmetrically aligned indexable inserts
- highly tough due to the high speed steel- core cutting edge in the centre



Figure 9.22

Cemented carbide drill with internal coolant supply (photo by Hermann Bilz GmbH & Co KG, Esslingen, www.Hermann-Bilz.de)

Drills like these are suitable for all drilling depths up to $7 \times D$. The advantages of these drills are:

- reliable coolant supply to the cutting edges. Optimal coolant pressure is at 6 bar; necessary coolant volume amounts to 3 l/min.

- long tool life and low cutting forces due to optimal lubrication and optimised TiN coating.

9.7.1.7 Twist drills - special shapes

It is impossible to economically carry out all drilling operations with standard drilling tools. This is why some special shapes were designed.

a) *Subland- twist drills – stepped drills*

These drills are used to generate holes with counterbores/ countersinks in a drilling operation. Stepped drills (Figure 9.23) save time, but they require extensive preparation.

These drills appear as multi-cut drills, for example, to generate counterbores/ countersinks for fillister head cap screws- or countersunk head screws (Figure 9.24), DIN 84, DIN 912 and DIN 6912 with 180° countersinking angle or DIN 63 and DIN 91 with 90° countersinking angle.



Figure 9.23
Multi-cut drills (photo by Gühring, Albstadt)

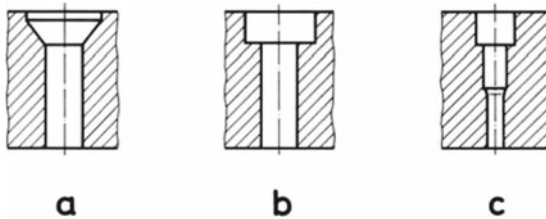


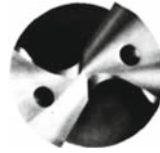
Figure 9.23a – c
Counterbores/ countersink generated with multi-cut drills
a) for countersunk head screw, b) for fillister head cap screw, c) countersink stepped twice.

b) *Drills with coolant ducts*

These drills have coolant ducts that are capable of pressing the coolant immediately to the cutting position. The coolant flows back in the helical flute and supports chip removal (Figure 9.24).

These drills are used for deep ($L > 3 \cdot d$) holes and hard working materials. Due to intensive cooling at the cutting position, where heat is generated, these drills allow higher cutting speeds and greater feeds and/or have better wear characteristics.

Figure 9.24
Drills for cooling ducts (photo by Gühling, Albstadt)



c) *Taper pin hole drill* (DIN 1898)

Taper pin hole drills (Figure 9.25) are tapered drills used to manufacture tapered holes with a taper of 1 : 50. They are required for taper pins according to DIN 1 and DIN 7978.

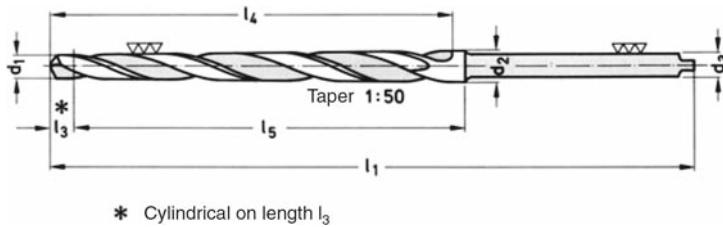


Figure 9.25
Taper pin hole drill (taper 1 : 50)

9.7.2 Helical counterbore

The helical counterbore is a tool to drill out pre-drilled holes in steel and pre-cast holes in grey cast iron.

Since the helical counterbore (Figure 9.26) has no tool point, the pre-drilled hole must not fall below

$$0,7 \times \text{drill, diameter.}$$

The helical counterbore has 3 cutting edges. Angle, tool side rake (helix angle) and point angle correspond to the normal twist drill, type N (Figure 9.27a).

Helical counterbores are used according to DIN 343 and 344 with taper- or parallel shank up to a diameter of 50 mm.

For large holes (greater than 50 mm Ø), the 4-edged arbour-type counterbore according to DIN 222 (Figure 9.27b) is available.

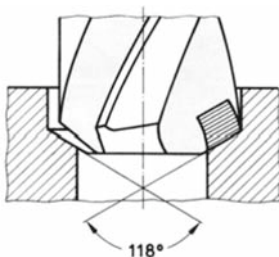


Figure 9.26
Design of the bit for a helical counterbore

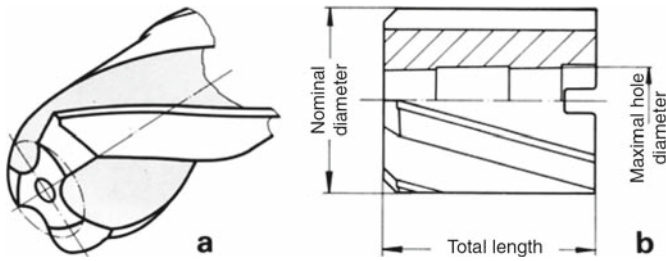


Figure 9.27
Helical counterbore geometries, a) 3-edged helical counterbore, b) 4-edged arbour-type counterbore

Due to the construction of the cutting edges, helical counterbores (3 or 4 cutting edges) have a better guidance than twist drills. For this reason, with helical counterbores, we can achieve better surface qualities and lower tolerances than for drilling out with twist drills. An example of a boring tool with replaceable cutting edges is the burr manufactured by the firm Bilz, Esslingen, known under the German name “Bilzmesser” (Bilz blade). This is a 3-edged boring tool (Figure 9.28), to be delivered in high speed steel and cemented carbide design.



Figure 9.28
Burr (Bilzmesser) for drilling out (Photo by Bilz, Esslingen)

The tools' dimensions range from 30 to 220 mm diameter. The boring tool itself (the Bilz blade) is connected with the tool holder with a positive-locking joint. The dowel pin can be changed and is modified according to the size of the pre-drilled hole.

The counterbore (Figure 9.29) according to DIN 1862 is a tool to manufacture exact holes. It is used on co-ordinate- and horizontal-drilling machines. In these tools, the Morse taper has an internal tapped shank.



Figure 9.29
Counterbore DIN 1862 with internal tapped shank

9.7.3 Spot facers, countersinks and special-shape countersinkers

are used to produce areas of contact, hollows and shaped surfaces. *Spot facers* (Figure 9.30) have a dowel pin plunging into the pre-machined hole. This dowel pin may be in a fixed connection with the body or replaceable. As a negative effect of the fixed pin is that it diminishes in diameter during resharpening.

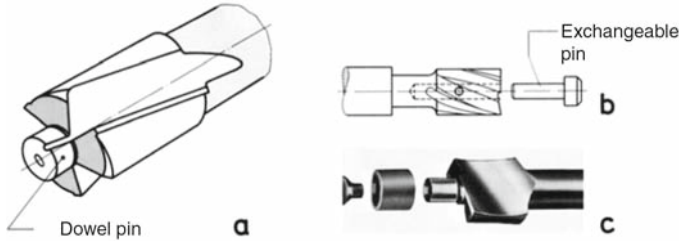


Figure 9.30

Spot facer

a) with fixed, b) with replaceable dowel pin, c) with replaceable guide bush

Countersinks (Figure 9.31) are made with parallel shank and Morse taper. The most frequent taper angles α are:

- 60° at (for) DIN 334
- 90° at DIN 335
- 120° at DIN 347

Furthermore, other special shapes for certain ranges of application also exist.

Special-shape countersinkers (Figure 9.32) are special tools that may have a special geometry. These countersinkers are produced with/ without dowel pin. The dowel pin is preferentially used in cases where the countersink and hole need to have an exact mutually-centred position.

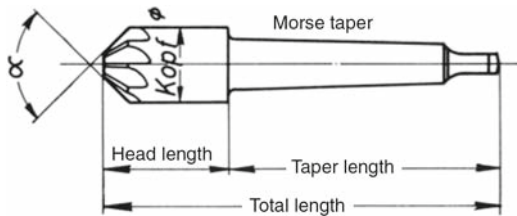


Figure 9.31

Countersink 90°, straight-fluted – right-hand cut, DIN 335



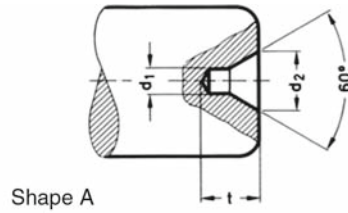
Figure 9.32

Special-shape countersinker with dowel pin

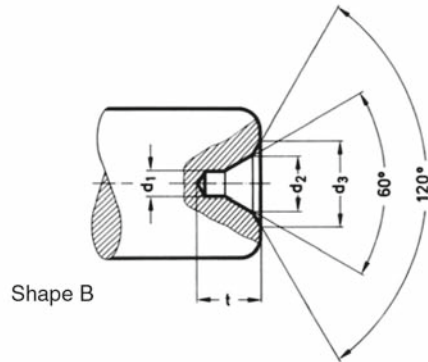
9.7.4 Centre drills

are special drills to manufacture centre holes (Figure 9.33).

Shape A
without countersunk recess with straight-lined bearing surfaces (to be drilled with centre drills 60°, shape A according to DIN 333)



Shape B
with tapered countersunk recess and straight-lined bearing surfaces (to be drilled with centre drills shape B according to DIN 333)



Shape R
without countersunk recess with rounded bearing surfaces (to be drilled with centre drill shape R according to DIN 333)

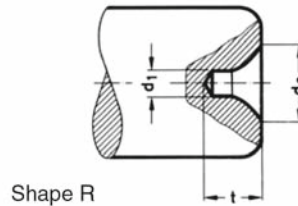


Figure 9.33

Centre holes according to DIN 332

shape A without countersunk recess with straight-lined bearing surfaces

shape B with tapered countersunk recess and straight-lined bearing surfaces,

shape R without countersunk recess with rounded bearing surfaces

Centre holes with 60° taper angle are standardised in DIN 332. The shapes are subdivided into:

shape A: without countersunk recess with straight-lined bearing surfaces

shape B: with tapered countersunk recess and straight-lined bearing surfaces

shape R: without countersunk recess with rounded bearing surfaces

The centre drills are straight- or helical fluted and right-hand cut.

To manufacture centre holes of shape A and R, centre drills according to DIN 333 B are used. To produce shape B, centre drills according to DIN 333 A or DIN 333 R (Figure 9.34) are used.

Centre drill DIN 333

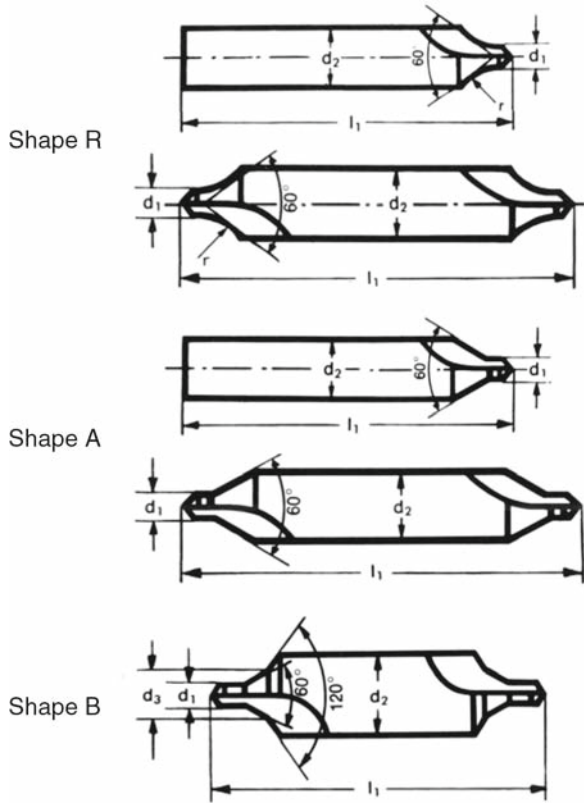


Figure 9.34
Centre drill according to DIN 333 shapes A, B and R
(Photo by Günther & Co, Frankfurt)

A centre drill with a taper angle of 60°, shape B, $d_1 = 4$ mm, $d_2 = 14$ mm, is called the centre drill B4 × 14 DIN 333.

The table below is an excerpt from DIN 333 and elucidates the construction sizes of some centre drill dimensions.

Table 9.10 Centre drill dimensions (excerpt from DIN 333 shape B)

d_1	d_2	l_1
1	4	35,5
2	8	50
3,15	11,2	60
4	14	67

9.7.5 Boring tools

Boring of holes with a turning tool attached to the boring bar is a well known procedure.

Special boring tools are designed to bore fine holes with narrow tolerances and high surface quality.

These are tool heads tipped with one or two replaceable cutting edges. The corresponding cutting edges can be adjusted in the tool head, so that any size desired can be generated (Figure 9.35).

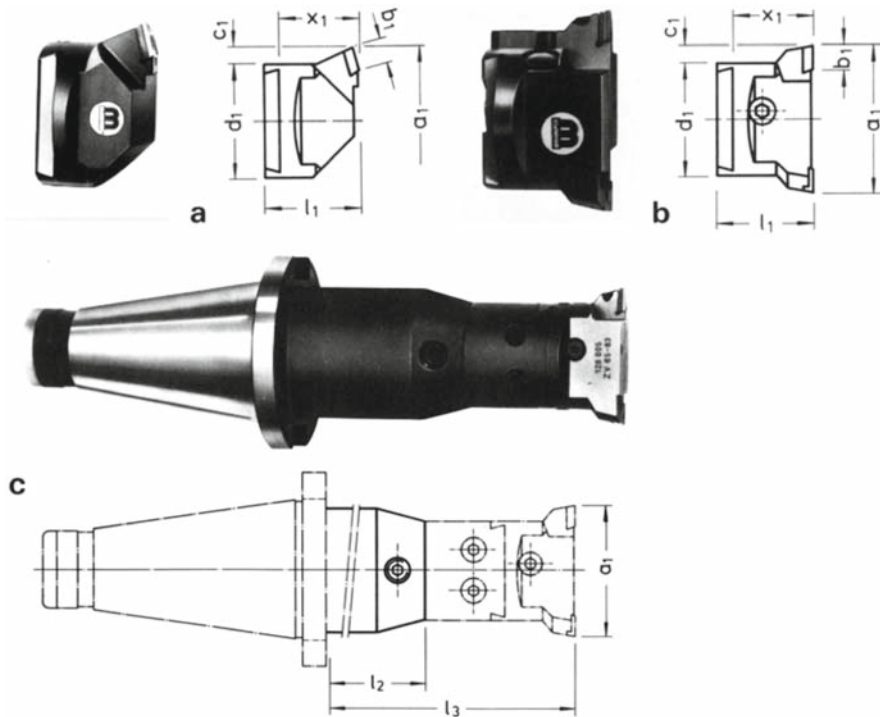


Figure 9.35
Tool heads, a) with one cutting edge, b) with two cutting edges
(Photo by Wohlhaupter, Frickenhausen)

These tool heads (Figure 9.35a/b) can be put on customised tool shanks (Figure 9.35c) to be delivered in various diameter- and length increments. Shanks with standardised steep tapers according to DIN 2080 or cylindrical mountings are planned. It is possible to extend the tool shanks using adapters, thereby adapting them to the corresponding cutting conditions.

The range of diameters drilled out is from 29 to 205 mm.

Another principle to bore holes, to turn shoulders and recess plane grooves is demonstrated in the example of the facing- and boring head (Figure 9.36) by the firm Röhm.

Here, the boring tool is clamped in a cross slide to be swivelled sidewise up to a maximum of 50 mm. The fine adjustment of the slide is 0,01 mm per graduation line at the scale ring.

Figure 9.36a shows the ranges of application for such boring heads.

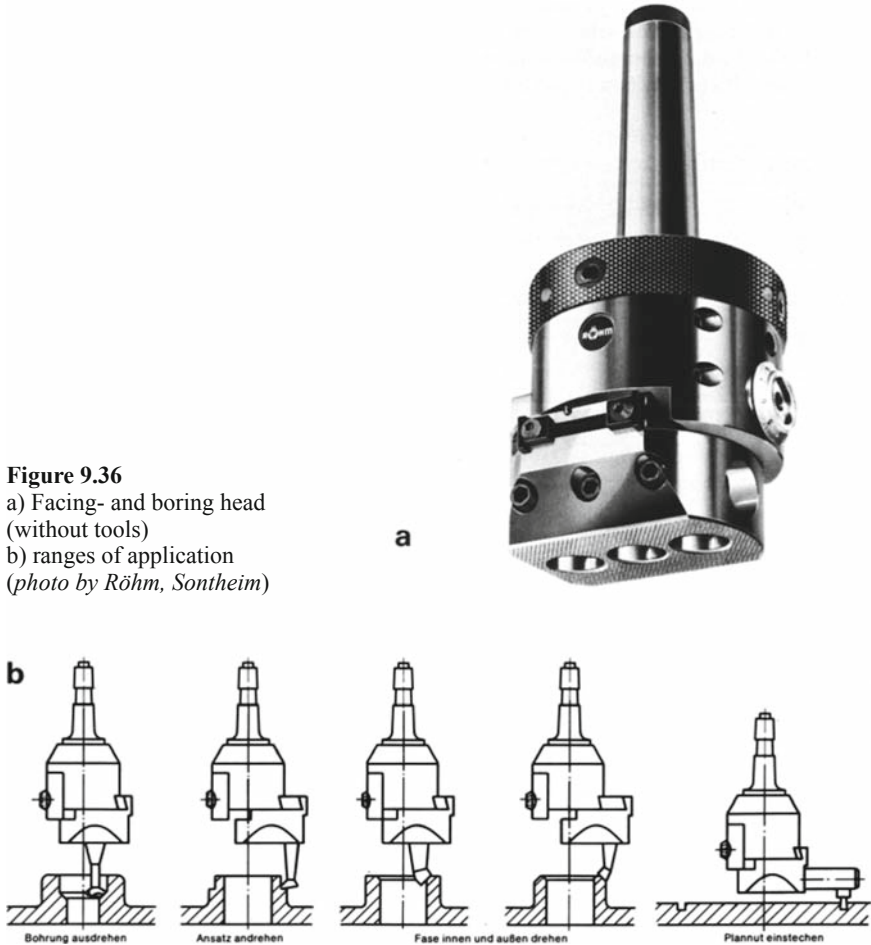


Figure 9.36
a) Facing- and boring head
(without tools)
b) ranges of application
(photo by Röhms, Sontheim)

9.7.6 Reaming tools

The reamer is the tool used for reaming. As the twist drill, the reamer can be subdivided into 2 segments: the shank and the body (Figure 9.37). The body has a conical front (bevel lead) that is followed by a cylindrical segment. Metal removal work is exclusively performed by the bevel lead. The cylindrical segment is purely designed for smoothing and guidance. The hand reamer has a complementary angle of the bevel lead angle of 2°. The long bevel lead is needed so that the reamer may centre itself in the hole. The machine reamer (Figure 9.38) has a short bevel lead with a complementary angle of the bevel lead angle von 45°. This short bevel

lead is sufficient, since it is guided through the shank clamped into the machine. The number of reamer flutes is generally even-numbered, which means that 2 cutting edges are always located across from each other. Thus, the reamer diameter is easy to measure. However, to avoid chattering phenomena, the pitch between the flutes (Figure 9.39) is heterogeneous. The grooves of the reamer are predominantly straight-lined. Helical flutes to the left are used for interrupted holes.

To machine very tough materials, reamers with right-handed helical flutes are applied. The normal reamer generates an H 7-hole (system basic hole). But there are also reamers with special dimensions available.

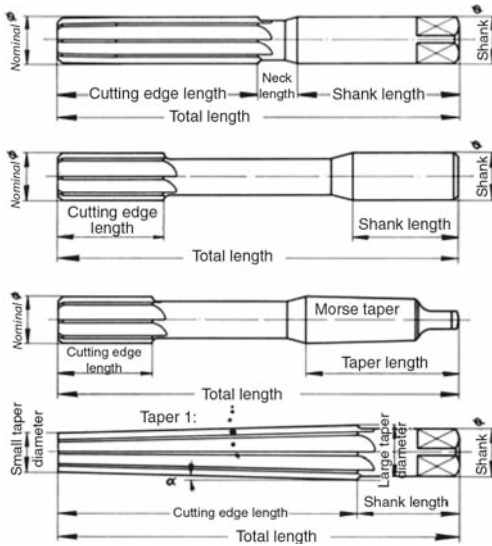


Figure 9.37
Elements of a reamer (body - shank) 1 hand reamer, 2 machine reamer with parallel shank, 3 machine reamer with Morse taper, 4 taper reamer (photo by Boeklenberg Söhne, Wuppertal)

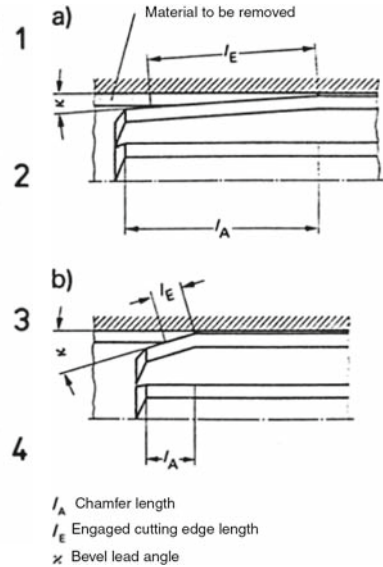


Figure 9.38
Segment view of a reamer a) at hand-, b) at machine reamers I_A chamfer length, I_E engaged cutting edge length, x complementary angle of the bevel lead angle

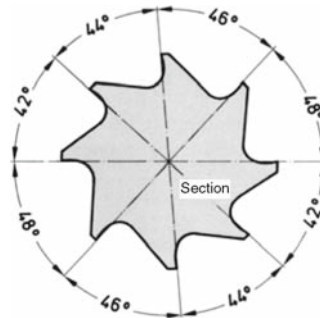


Figure 9.39
Number of teeth and pitch of a reamer.

The narrow guiding land (Figure 9.40) has a tool orthogonal clearance, which is whetted with an oilstone. It is about 4°. Rake angles for machining of steel range from 0 to 6°.

Reamers are classified:

according to the type of operation:

- hand-
- machine reamers

according to shape:

- cylindrical-
- taper reamers-

according to size:

- Solid measure reamers-
- adjustable

reamers.

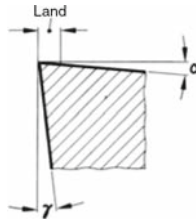


Figure 9.40
Rake angle and tool orthogonal clearance of a whetted land

In machine reamers, the cutting edges are shorter than in hand reamers, since they are carried by the machine. The shank is equipped with a Morse taper. Shell reamers (Figure 9.41) that are set on boring bars are available for long holes.

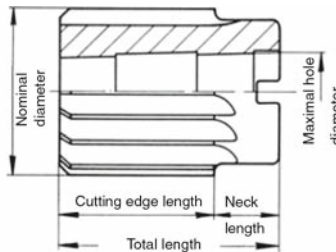


Figure 9.41
Shell reamer

Taper reamers are required to manufacture tapered holes for taper pins according to DIN 1. The tapered reamers according to DIN 9 therefore required have a taper ratio of 1 : 50.

To generate Morse tapers, taper reamers according to DIN 204 are in use. In adjustable reamers, the cutting edges can be readjusted. It is possible to compensate for reamer wear thanks to adjustability.

Adjustment is achieved through expansion by means of a cone or by shifting the blades on a cone.

Expanding reamers (Figure 9.42) have a split body, which may be expanded by screwing in a taper up to 0,3 mm.

Blade reamers have inserted cutting edges, which can be shifted on a cone through 2 nuts. These reamers are adjustable from 0,5 to 3,0 mm.

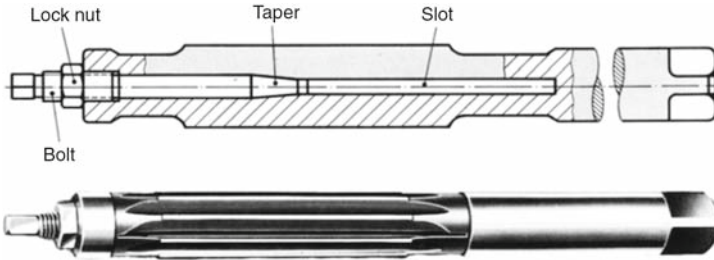


Figure 9.42
Adjustable reamer, adjustable by means of an expansion arbour

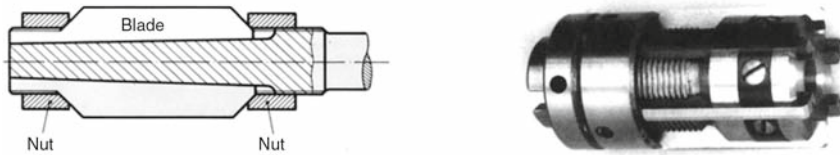


Figure 9.43
Adjustable reamer with inserted blades

9.7.7 Taps

Taps are designed to produce inner threads (threads in a nut). They are offered as tap sets and individual taps.

A set may include 3 or 2 taps. A three-tap set consists of :

- entering tap
- second or plug tap
- third tap

A two-tap set only includes:

- entering tap and
- final tap

Machine taps are, as a rule, individual taps that pre- and finish cut the thread.

The thread to be cut with a tap (Figure 9.44) has to conform with all standard parameters.

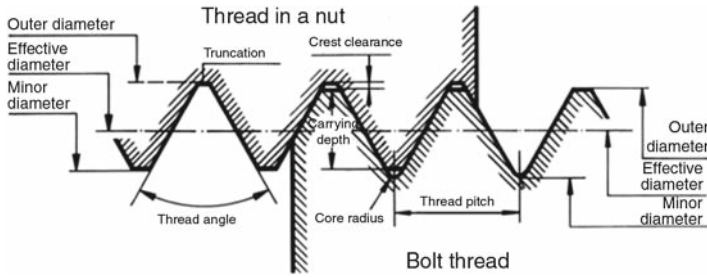


Figure 9.44
Thread profiles for bolts and nuts

The tap consists of shank and thread segment. A square at the end of the shank ensures positive-locking mounting both for hand- and machine taps.

The function of the body (Figure 9.45) is determined by the groove design and the formation of the bevel lead.

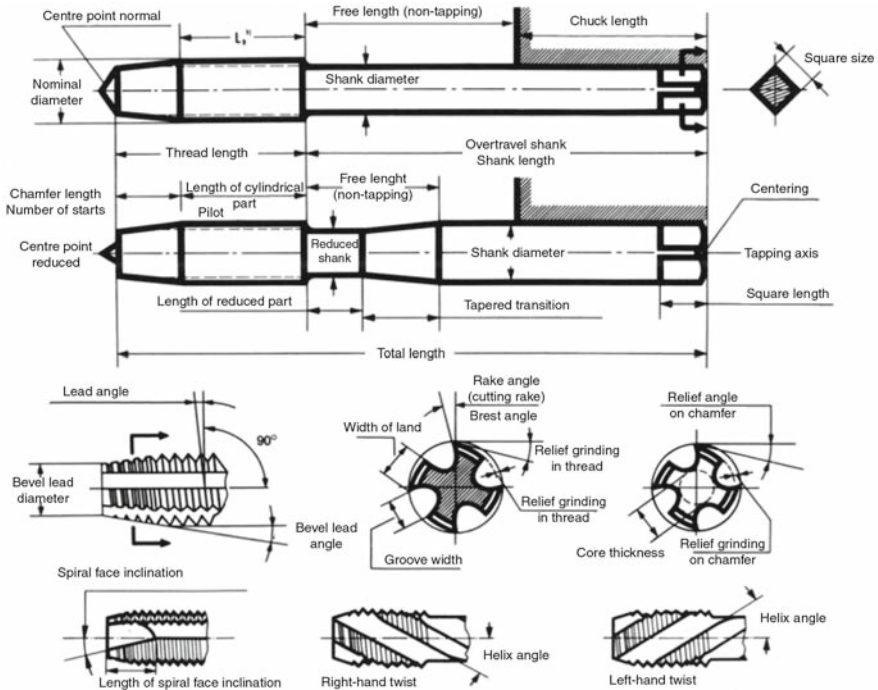


Figure 9.45
Structure and denomination of a tap
(photo by Günther & Co., Frankfurt)

In machine taps, we find three bevel lead types. The bevel lead type to be selected for each application depends on the type of the tapped hole. An overview is given in Table 9.11.

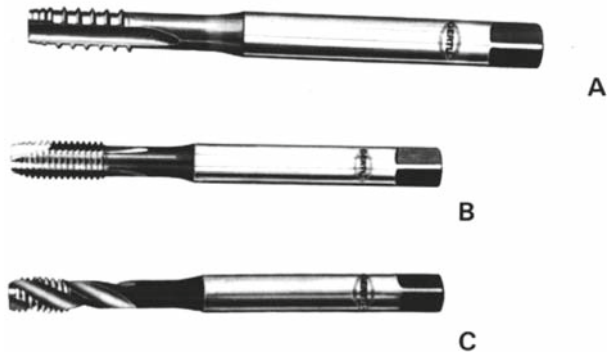
Table 9.11 Examples of application for different bevel lead types (Figure 9.46).

Bevel lead type	Chamfer length in the number of turns	Application
A	5–6	for short through holes (length < thread diameter)
B	5 and additional spiral face inclination	through holes with greater thread depths
C	2–3	for blind holes

Taps with spiral face inclination (shape B) convey the chips in feed direction. Thus, the grooves are kept free, and the coolant gets to the cutting edges without hindrance. Spiral face inclination angle is 15° .

Flute construction at the tap (Figure 9.45 and 9.46)

The straight-lined groove is sufficient in standard cutting procedures and is preferentially used for through holes. If chip space is large enough, then we can use straight-fluted taps even for blind holes. The straight-lined groove can be easily reground.

**Figure 9.46**

Single tooth machine tap DIN 371 with reinforced shank

Shape A straight-fluted-offset teeth

Shape B straight-fluted with spiral face inclination

Shape C right-handed helix – helix angle 35°

(Photo by Gertus-Werkzeugfabrik, Wuppertal)

Helical flutes

Chip flow is improved by helical flutes. Two types are distinguished:

Helical flutes – left-handed helix

remove the chips in feed direction. For this reason, they can be used only for through holes, since they provide free chip flow in feed direction.

Helical flutes – right-handed helix

direct the chips in the direction opposite to that of the feed, backward in the shank direction. For this reason, right-handed helix taps are used for blind holes. The normal helix angle is around 15°.

Taps with right-handed helical flutes, in which the flutes are particularly wide-spaced and the helix angle is large (35°), are used for deep blind holes. The taps' rake angles range from 3 to 20°.

Table 9.12 Tap rake angle

Material	Grey cast iron	Steel		Light metal (long-chip)
		$R_m \leq 500 \text{ N/mm}^2$	$R_m > 500 \text{ N/mm}^2$	
rake angle	3°	15°	8–10°	20°

9.8 Failures in drilling

Table 9.13 Failures and corresponding reasons in drilling

9.8.1 Tool failures		
Consequences for the tool	Reason for the failure	Remedy
Drill hooks in and breaks	Point angle too small	Select greater point angle
Tang damaged or broken off	Drill cone, or cone in the drilling machine contaminated or damaged	Repair cone
Drill fracture	Drill core too weak	Use more stable drill
Excessive land wear	Unilateral grinding of the bit	Grind bit centrally
Fracture of the drill	Feed too high flutes clogged	Take smaller feed frequently remove chips from flutes
Excessive land wear	Cutting speed too high poor cooling	Diminish cutting speed improve cooling
Premature dulling of the drill	Cutting speed too high poor cooling	Diminish cutting speed enhance cooling
Drill point with temper colour	Cutting speed too high feed at deep holes too high poor cooling	Diminish cutting speed reduce feed enhance cooling

9.8.2 Workpiece failures		
Failure in the hole	Reason for the failure	Remedy
Collars at the hole's upper side, burr formation at the lower side burr formation	Drill was dull	Sharpen tool
Wall of the hole very rough	Drill was dull	Sharpen tool
Hole becomes noncircular in thin-walled workpieces and sheet metal	Drill has poor guidance	Use drill with centre point or increase point angle

9.9 Reference values for drilling methods

The reference values recommended are applicable for tool life travel $L = 2000$ mm.

Cutting speeds and feed values for boring and counterboring with helical counter bores

For boring and counterboring with helical counterbores, there are applicable approximately the same reference values apply as for drilling with twist drills.

For helical counterbores, consider the values of Table 9.15 - cutting speeds as maximal- and the feed values as minimal values.

Table 9.14 Spot facing with spot facing tools and smoothing blades made of high speed steel

Material	v_c in m/min	Feed f in mm per revolution for					
		Diameter D in mm					
		5	6,3	10	16	25	40
Unalloyed steels to 700 N/mm ²	10–13	0,05	0,06	0,07	0,09	0,11	0,14
Unalloyed steels and unalloyed steels 700–900 N/mm ²	7–9	0,04	0,04	0,05	0,05	0,06	0,07
Grey cast iron GJL 200–GJL 250	10–14	0,05	0,06	0,07	0,09	0,11	0,14
Brass CuZn 37	14–20	0,05	0,05	0,07	0,08	0,10	0,12
Al alloys	28–50	0,05	0,06	0,07	0,09	0,11	0,14

Table 9.15 Reference values for drilling with twist drills made of high speed steel for drilling depths $t = 5 d$ (values in brackets are applicable for cemented carbide tools), f in mm per revolution, n in min^{-1} (excerpt from the company catalogue “Titex Plus”, from Günther & Co., 6 Frankfurt)

Materials	v_c in m/min (Average values)		Drill diameter d in mm						
			2,5	4	6,3	10	16	25	40
Unalloyed mild steels to 700 N/mm ² for example C 10, C 15, C 35 for example S 275 JR, C 35 E	32	n	4000	2500	1600	1000	630	400	250
		f	0,05	0,08	0,12	0,18	0,25	0,32	0,4
Unalloyed mild steel 700 N/mm ² alloyed steel up to 1000 N/mm ² for example C 45, Ck 45, 34Cr4, 22NrCr14, 25CrMo5	20	n	2500	1600	1000	630	400	250	160
		f	0,05	0,08	0,12	0,18	0,25	0,32	0,4
Alloyed steel 1000 N/mm ² for exam- ple 36CrNiMo4, 20MnCr5,50CrMo4, 37MnSi5	12	n	1600	1000	630	400	250	160	100
		f	0,04	0,06	0,1	0,14	0,18	0,25	0,32

Grey cast iron up to 250 N/mm ² GJL 150–GJL 250	20 (32)	<i>n</i>	2500 (4000)	1600 (2500)	1000 (1600)	630 (1000)	400 (630)	250 (400)	160 (250)
		<i>f</i>	0,08 (0,04)	0,12 (0,06)	0,2 (0,1)	0,28 (0,14)	0,38 (0,18)	0,5 (0,25)	0,63 (0,32)
			2000 (4000)	1250 (2500)	800 (1600)	500 (1000)	320 (630)	200 (400)	125 (250)
Grey cast iron 250 N/mm ² for example GJL 300–GJL 400	16 (32)	<i>n</i>	0,06 (0,03)	0,1 (0,05)	0,16 (0,08)	0,22 (0,11)	0,3 (0,15)	0,4 (0,2)	0,5 (0,25)
		<i>f</i>							
			8000 (16000)	5000 (10000)	3200 (6400)	2000 (4000)	1250 (2500)	800 (1600)	500 (1000)
Brass brittle, e.g. Ms 58 (CuZn 42)	63	<i>n</i>	5000 (10000)	3200 (6400)	2000 (4000)	1250 (2500)	800 (1600)	500 (1000)	320 (640)
Brass tough, for example Ms63 (CuZn 37)	40	<i>n</i>	0,08 (0,04)	0,12 (0,06)	0,2 (0,1)	0,28 (0,14)	0,38 (0,18)	0,5 (0,25)	0,63 (0,32)
		<i>f</i>							
Aluminium alloys (slightly alloyed)for example AlMgSiPb, AlCuMg 1	63	<i>n</i>	0,06 (0,03)	0,1 (0,05)	0,16 (0,08)	0,22 (0,11)	0,3 (0,15)	0,4 (0,2)	0,5 (0,25)
		<i>f</i>							
Aluminium alloys up to 11% Si for example G-AlSi 5 Cu 1 G-AlSi 7 Cu 3 G-AlSi 9 (Cu)	50	<i>n</i>	8000 (16000)	5000 (10000)	3200 (6400)	2000 (4000)	1250 (2500)	800 (1600)	500 (1000)
		<i>f</i>	0,08 (0,04)	0,12 (0,06)	0,2 (0,1)	0,28 (0,14)	0,38 (0,18)	0,5 (0,25)	0,63 (0,32)

At drilling depths > 5 · d to 10 · d values diminish by 20%

Table 9.16 Reference values for reaming with high speed steel tools

Material	<i>v_c</i> in m/min	Feed <i>f</i> in mm for <i>d</i> in mm				
		5	12	16	25	40
Unalloyed steel up to 700 N/mm ²	8–10	0,1	0,2	0,25	0,35	0,4
Unalloyed steel up to 900 N/mm ²	6–8	0,1	0,2	0,25	0,35	0,4
alloyed steel > 900 N/mm ²	4–6	0,08	0,15	0,2	0,25	0,35
grey cast iron < 250 N/mm ² > 250 N/mm ²	8–10	0,15	0,25	0,3	0,4	0,5
	4–6	0,1	0,2	0,25	0,35	0,4
brass Ms 63 (CuZn 37)	15–20	0,15	0,25	0,3	0,4	0,5

Table 9.17 Lower deviation in mm, for reamers made of high speed steel and cemented carbide

Diameter in mm	High speed steel reamer		Cemented carbide reamer	
	Soft materials	Steel steel casting	Soft materials	Steel steel casting
up to 10	0,2	0,1	0,2	0,15
11–20	0,35	0,15	0,3	0,25
21–30	0,5	0,3	0,4	0,3
31–50	0,7	0,4	0,5	0,35
> 50	0,9	0,6	0,6	0,5

Table 9.18 Reference values for thread cutting with machine taps (single tap)

Material	v_c in m/min (average)		Rake angle γ	Cooling lubricants
	Tool material			
	HS	tool steel		
Steel up to 700 N/mm ² for example C 10, C 15, C 35, S 275 JR	16	6	10–12°	E 0
Unalloyed steel 700 N/mm ² alloyed steel up to 1000 N/mm ² for example C 45, 34Cr4, 22NiCr14, 38MnSi4	10	3	6–8°	0 E
Alloyed steel 1000 N/mm ² for example 42MnV7, 36 CrNiMo4 20MrCr5, 37MnSi 5	5	–	8–10°	0 E
Grey cast iron 250 N/mm ² GJL 100–GJL 250	10	7	5–6°	P E T
Grey cast iron 250 N/mm ² GJL 300–GJL 350	8	6	0–3°	P E
Brass brittle	25	15	2–4°	0 T
Brass tough Ms 63 (CuZn 37)	16	10	12–14°	0 E
Al alloys (long-chipping) AW-AlCu4MgSi	20	14	20–22°	E
Al alloys up to 11% Si	16	10	16–18°	E
Cooling lubricants abbreviated O = oil P = Naphta E = emulsion T = dry (without lubricant)				

Table 9.19 Drill diameter for tapping drill holes for metric ISO coarse-pitch threads DIN 13

Nominal thread diameter	Pitch in mm	Drill diameter in mm
M 3	0,5	2,5
M 4	0,7	3,3
M 5	0,8	4,2
M 6	1,0	5,0
M 8	1,25	6,8
M 10	1,5	8,5
M 12	1,75	10,2
M 16	2,0	14,0
M 20	2,5	17,5
M 24	3,0	21,0
M 27	3,0	24,0
M 30	3,5	26,5

9.10 Examples

Example 1

Drill a through hole 16 mm Ø H 7 in each of 30 plates according to sketch (Figure 9.47), made of C 45.

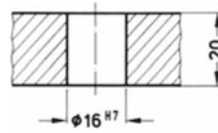


Figure 9.47
Plate made of C 45 with tolerance hole 16 H 7

Sought for:

1. Drilling tool – type and diameter
2. Reamer
3. Input power for drilling; $\eta_M = 0,7$
4. Required machine time for drilling

Approach:

1. Choice of drill

Lower deviation for reaming, cemented carbide reamers, is 0,25 mm according to Table 9.17. Consequently, drill diameter is 15,75 mm. Thus, the drilling tool is defined:

twist drill according to DIN 345 with taper shank (Morse taper 2)

$d = 15,75$ mm, standard name: 15,75 DIN 345

Select according to Table 9.8, p. 110: Type N, point angle $\sigma = 118^\circ$

2. Reamer

A machine reamer with screwed on cemented carbide blades according to DIN 214, diameter 16 H 7 is chosen.

3. Input power for drilling

from Table 9.15: $f = 0,25$ mm, $n = 400$ min⁻¹, $v_c = 20$ m/min

$$f_z = \frac{f}{2} = \frac{0,25 \text{ mm}}{2} = 0,125 \text{ mm/cutting edge}$$

$$h = f_z \times \sin \frac{\sigma}{2} = 0,125 \text{ mm} \cdot 0,857 = 0,107 \text{ mm}$$

$$b = \frac{d}{2 \cdot \sin \frac{\sigma}{2}} = \frac{15,75 \text{ mm}}{2 \times 0,857} = 9,19 \text{ mm}$$

$k_{c1,1} = 2220$ N/mm² from Table 1.1

$$k_{ch} = \frac{(1 \text{ mm})^z}{h^z} \times k_{c1,1} = \frac{(1 \text{ mm})^z}{0,107^{0,14} \text{ mm}} \times 2220 \text{ N/mm}^2 = 3036 \text{ N/mm}^2$$

$$k_c = k_{ch} \cdot K_v \cdot K_{st} \cdot K_{ver}$$

$$k_c = 3036 \text{ N/mm}^2 \cdot 1,15 \cdot 1,2 \cdot 1,3 = 5446,58 \text{ N/mm}^2$$

$$M = \frac{d^2}{8} \times f_z \times z_E \times k_c \times \frac{1}{10^3 \text{ mm/m}}$$

$$= \frac{15,75^2 \text{ mm}^2 \times 0,125 \text{ mm} \times 2 \times 5446,58 \text{ N/mm}^2}{8 \times 10^3 \text{ mm}^2} = 42,22$$

$$P = \frac{M \cdot n}{9,55/\text{min} \cdot 10^3 \text{ W/kW} \cdot \eta_M} = \frac{42,22 \text{ Nm} \cdot 400 \text{ min}^{-1}}{9,55/\text{min} \cdot 10^3 \text{ W/kW} \cdot 0,7} = 2,53 \text{ kW}$$

4. Machining time t_h (machine time)

$$L = \frac{d}{3} + 3 + l = \frac{15,75 \text{ mm}}{3} + 3 \text{ mm} + 20 \text{ mm} = 28,25 \text{ mm}$$

$$t_h = \frac{L \times i}{f \times n} = \frac{28,25 \text{ mm} \times 30 \text{ Stck.}}{0,25 \text{ mm} \times 400 \text{ min}^{-1}} = 8,47 \text{ min for 30 pcs.}$$

Example 2

Counterbore according to DIN 75 for hexagon socket screws M 12 DIN 912.

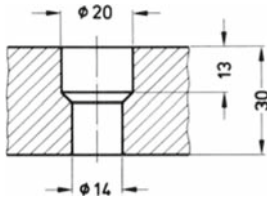


Figure 9.48
Plate with stepped hole

Given:

Material E 295

Counterbore to be cut with a spot facer, ($z = 4$ cutting edges)

Sought for:

1. Select twist drill
2. Input power for counterboring
3. Machining time for counterboring

Approach:

1. Twist drill 14 DIN 345, type N, $\sigma = 118^\circ$
from Table 9.15: $v_c = 12 \text{ m/min}$; $f = 0,10 \text{ mm}$; $z_E = 4$ cutting edges

2. Input power for counterboring

$$n = \frac{v_c \times 10^3}{d \times \pi} = \frac{12 \text{ m/mm} \times 10^3 \text{ mm/m}}{20 \text{ mm} \times \pi} = 191 \text{ min}^{-1}$$

$$n = 224 \text{ min}^{-1} \text{ (standard speed) selected}$$

$$h = f_z = \frac{f}{z} = \frac{0,1 \text{ mm}}{4} = 0,025 \text{ mm}$$

$$k_{c1,1} = 1990 \text{ N/mm}^2 \text{ (from } k_c \text{- Table 1.1), } z = 0,26$$

$$k_{c_h} = \frac{(1 \text{ mm})^z}{h^z} \times k_{c1,1} = \frac{(1 \text{ mm})^z}{0,025^{0,26} \text{ mm}} \times 1990 \text{ N/mm}^2 = 5193 \text{ N/m}^2$$

$$k_c = k_{c_h} \cdot K_{\text{ver}} \cdot K_v \cdot K_{\text{st}}$$

$$k_c = 5193 \text{ N/mm}^2 \cdot 1,3 \cdot 1,15 \cdot 1,2 = 9316,24 \text{ N/mm}^2$$

$$M = \frac{(D^2 - d^2) \times z_E \times f_z \times k_c}{8 \times 10^3 \text{ mm/m}}$$

$$M = \frac{(20^2 - 14^2) \text{ mm}^2 \times 4 \times 0,025 \text{ mm} \times 9316,24 \text{ N/mm}^2}{8 \times 10^3 \text{ mm/m}}$$

$$M = 23,76 \text{ Nm}$$

$$P = \frac{M \times n}{9,554 \times 10^3 \times \eta_M}$$

$$= \frac{23,76 \text{ Nm} \times 224 \text{ min}^{-1}}{9,554 \text{ s/min} \times 10^3 \text{ W/kW} \times 0,7} = 0,8 \text{ kW}$$

3. Machining time

$L = l_a + l + l_u$ following Table 9.4, there is:

$$l_a = \frac{D-d}{3}, \quad l_u = 0, \quad l = t = 13 \text{ mm}$$

$$L = \frac{D-d}{3} + t = \frac{20 \text{ mm} - 14 \text{ mm}}{3} + 13 \text{ mm} = 15 \text{ mm}$$

$$t_h = \frac{L \times i}{f \times n} = \frac{15 \text{ mm} \times 1 \text{ Stck.}}{0,1 \text{ mm} \times 224 \text{ min}^{-1}} = 0,66 \text{ min/1 pce.}$$

10 Sawing

10.1 Definition

Sawing is a metal cutting procedure in which the multi-edged tool carries out both the cutting and the feed motions.

10.2 Sawing methods

10.2.1 Sawing with saw blade

The saw blade is the tool used in a hacksaw. The tool carrier of the hacksaw (Figure 10.1) performs a back-and-forth motion.

When carrying out this operation, the tool is in contact in only one motional direction (tensile direction of the saw frame). In the return motion, the saw blade is lifted upward, away from the workpiece, to avoid damage to the cutting edge. On the return stroke, the saw blade does not carry out any metal removal, which results in empty movement and wastes time. As a result of the limited saw blade length, only a few teeth are in contact. For this reason, the tool life of these saw blades is limited.

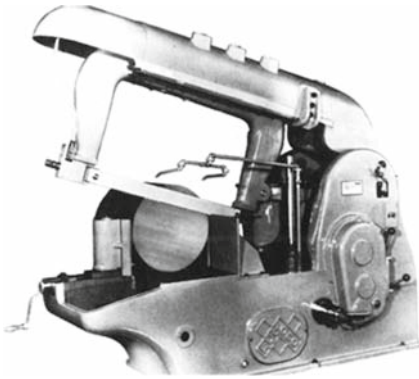


Figure 10.1
Hacksaw of the RSR type (*photo by Cordier, Menden*)

10.2.2 Sawing with endless belt-saw blades

In belt-saw blades (Figure 10.2), the tool is an endless belt. The mean elongated length of such belts ranges from 2.7 to 5.4m. Unlike the hacksaw, this procedure involves no wasted motion. Furthermore, in contrast to the saw blade, many teeth are in contact due to the belt length. As a result, band belt-saw blades exhibit longer tool life than hacksaw blades.

10.2.3 Sawing with circular saw blades

The circular saw blade, which is available in different design types, is the tool used in the circular sawing machine (Figure 10.3). We distinguish between saw blades

that are totally made of steel, in which the whole blade consists of the same material, and circular saw blades with inserted tooth segments made of high speed steel, or segments with inserted cemented carbide teeth.

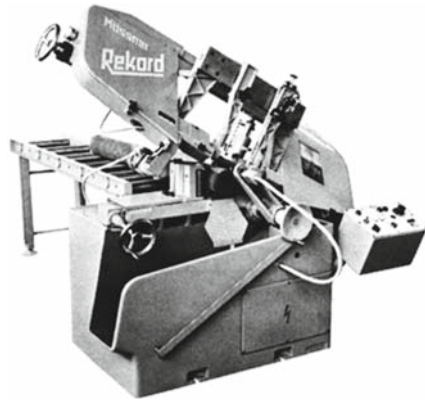


Figure 10.2
Band saw in resting position Type LBU 421
(photo by A. Mössmer, Mutlangen)

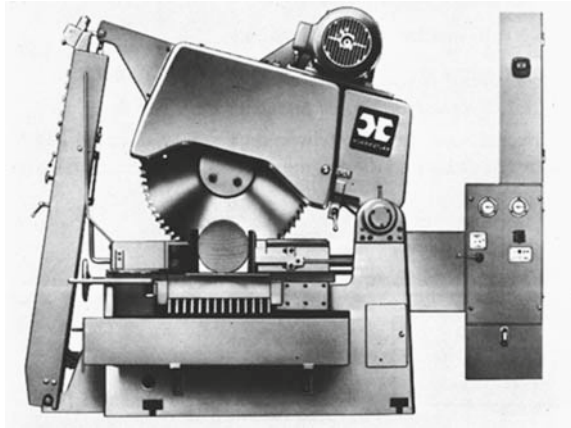


Figure 10.3
Cold circular saw with
swivelling frame model
type HDM 800 (photo by
Kaltenbach, Lörrach)

Circular saw blades have, in comparison with band saw blades, high stability and rigidity. Saw blades with less than 300 mm diameter, which are also used on milling machines, are called metal circular saws. They are standardised under DIN 1837 and DIN 1838.

10.3 Sawing methods - tasks and ranges of application

The most essential function of the sawing methods is parting off or cutting off rods and profiles to length, and cutting out break-throughs in disks, such as openings in die shoes for cutting dies.

10.4 Accuracy values achievable with sawing

In sawing, we distinguish between two types of accuracy.

Longitudinal accuracy indicates the repeatable accuracy at which a workpiece length can be cut off.

Angular accuracy indicates the precision in angularity of the cut off workpiece. As a rule, it is quantified in mm, related to 100 mm cutting height.

Table 10.1 Accuracy values achievable with sawing

Evaluated feature	Hacksaws	Belt saws	Circular saws
Longitudinal accuracy in mm	± 0,2–0,25	± 0,2–0,3	± 0,15–0,2
Angular accuracy in mm, related to 100 mm cutting height	± 0,2–0,3	With new saw belt ± 0,15 at the end of tool life ± 0,5	± 0,15–0,3

10.5 Calculation of forces and power

10.5.1 Laws valid for all sawing methods

10.5.1.1 Thickness of cut and width of cutting

In sawing, the tool cutting-edge angle is $\iota = 90^\circ$. Consequently, depth of cutting corresponds to the feed per tooth, and width of cutting to width of cut (Figure 10.4).

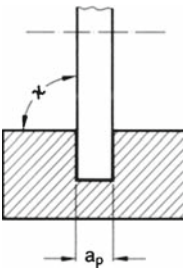


Figure 10.4
Tool cutting-edge angle $\iota = 90^\circ$, consequently $b = a_p$

$$h = f_z$$

$$b = a_p$$

- h in mm thickness of cut
- f_z in mm feed per tooth
- b in mm width of cutting
- a_p in mm width of cut

10.5.1.2 Specific cutting force

$$k_{c_h} = \frac{(1 \text{ mm})^z \cdot k_{c1,1}}{h^z} = \frac{(1 \text{ mm})^z \cdot k_{c1,1}}{f_z^z}$$

Taking into account the correction factors, then we obtain

$$k_c = \frac{(1 \text{ mm})^z}{f_z^z} \cdot k_{c1,1} \cdot K_v \cdot K_{st} \cdot K_{ver}$$

k_c	in N/mm ²	specific cutting force
$k_{c1,1}$	in N/mm ²	specific cutting force related to $h = b = 1 \text{ mm}$
f_{ch}	in N/mm ²	specific cutting force related to h^z
f_z	in mm	feed per tooth
z		exponent (material constant)
K_v		correction factor for cutting speed
		$K_v = 1,0$ for cemented carbide, $K_v = 1,15$ for high speed steel tools
K_{st}	= 1,2	correction factor for chip compression
K_{ver}	= 1,3	wear factor

The wear factor accounts for wear on the tool.

For tools that have been sharpened for machining, it is 1.0.

At the end of tool life, there is $K_{ver} = 1.3$.

10.5.1.3 Major cutting force per tooth

$$F_{c_z} = A \cdot k_c = a_p \cdot f_z \cdot k_c$$

F_{c_z}	in N	major cutting force per tooth
A	in mm ²	sectional area of chip
a_p	in mm	width of cut
f_z	in mm	feed per tooth

10.5.1.4 Total cutting force of teeth engaged

$$F_c = F_{c_z} \cdot z_E = a_p \cdot f_z \cdot k_c \cdot z_E$$

F_c	in N	total cutting force
F_{c_z}	in N	major cutting force per tooth
a_p	in mm	width of cut
f_z^p	in mm	feed per tooth
z_E		number of teeth engaged

10.5.1.5 Machine input power

$$P = \frac{F_c \cdot v_c}{10^3 \text{ W/kW} \cdot 60 \text{ s/min} \cdot \eta_M}$$

P	in kW	machine input power
F_c	in N	total cutting force
v_c	in m/min	cutting speed
η_M		machine efficiency

10.5.2 Calculations for sawing with saw blade or saw band

10.5.2.1 Feed per tooth

$$f_z = \frac{A_s \cdot T}{l \cdot v_c \cdot 10^3 \text{ mm/m}} = \frac{v_f \cdot l_B}{v_c \cdot 10^3 \text{ mm/m} \cdot z_w}$$

f_z	in mm	feed per tooth
$A_s = v_f \cdot l$	in mm ² /min	spec. area of cut (taken from Table 10.15 or 10.17)
T	in mm	saw pitch
l	in mm	length of cut
v_c	in m/min	cutting speed
v_f	in mm/min	feed rate
l_B	in mm	length of saw band
z_w		teeth number of the saw band

The length of cut is measured orthogonally to the feed direction (Figure 10.5). Consequently, only for round material only, material diameter is equal to the length of cut. In other profiles, the length of cut is the dimension situated orthogonally to the feed direction.

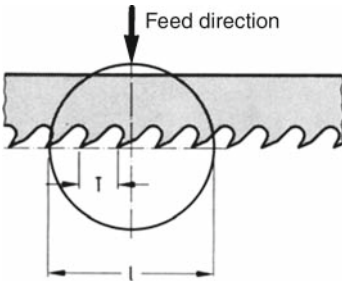


Figure 10.5
Feed direction, saw pitch T and length of cut l in sawing with saw blade or saw band

10.5.2.2 Number of teeth engaged

$$z_E = \frac{l}{T}$$

z_E		number of teeth in contact
l	in mm	length of cut (Figure 10.5)
T	in mm	saw pitch

10.5.3 Calculations for sawing with circular saw blade

10.5.3.1 Feed per tooth

$$f_z = \frac{A_s \cdot D \cdot \pi}{l \cdot v_c \cdot z \cdot 10^3 \text{mm/m}} = \frac{v_f \cdot D \cdot \pi}{v_c \cdot z \cdot 10^3 \text{mm/m}}$$

- f_z in mm feed per tooth
- A_s in mm²/min specific area of cut (to be taken from table)
- l in mm length of cut

$$l = \frac{\pi \cdot D \cdot \varphi_s^\circ}{360^\circ}$$

pressure angle at pitch point

$$\sin\left(\frac{\varphi_s}{2}\right) = \frac{B}{D}$$

If $D \gg B$, then we may approximately assume $l \approx B$

- v_c in m/min cutting speed
- z_w teeth number of circular saw blade
- D in mm saw blade diameter
- n in min⁻¹ rotational speed of the saw blade
- v_f in mm/min feed rate
- B in mm workpiece width
- φ_s in ° pressure angle at pitch point

In this method, length of cut is indicated orthogonally to feed direction (Figure 10.6).

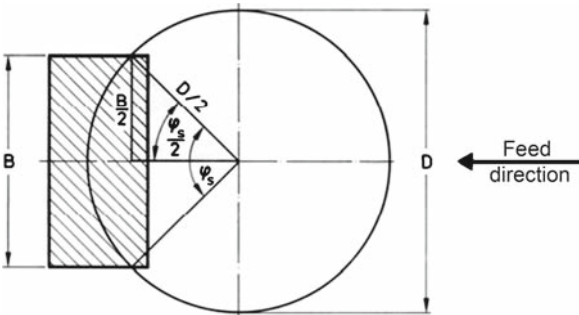


Figure 10.6
Length of cut at circular saw blade, $l = \text{arc length to } \varphi_s$

10.5.3.2 Number of teeth engaged

When sawing with circular saw blades, it is necessary first to calculate the pressure angle at pitch point φ_s . This angle can be obtained from approximate calculation according to the following equation (Figure 10.7).

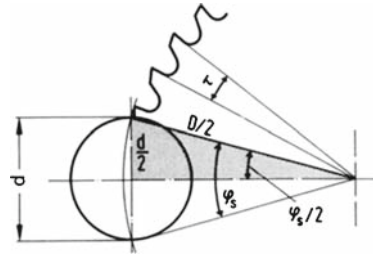


Figure 10.7
 Pressure angle at pitch point in circular saws
 D saw blade- \varnothing ; d workpiece diameter

$$\sin\left(\frac{\varphi_s}{2}\right) = \frac{d}{D}$$

$$z_E = \frac{\varphi_s^\circ \cdot z_w}{360^\circ}$$

- | | | |
|-------------|-------------|----------------------------------|
| z_E | | number of teeth engaged |
| z_w | | number of teeth on the saw blade |
| d | in mm | workpiece diameter |
| D | in mm | saw blade diameter |
| φ_s | in $^\circ$ | pressure angle at pitch point |

10.6 Calculation of machining time

The machining time can be calculated for all sawing methods according to the equation below:

$$t_h = \frac{A}{A_s}$$

- | | | |
|-------|-----------------------------|---|
| t_h | in min | machining time |
| A | in mm^2 | circumscribing cross-sectional area |
| A_s | in mm^2/min | specific cross-sectional area (from reference tables 10.15 and 10.17) |

If there are no empirical values for the specific cross-sectional area A_s , then it is possible to calculate machining time, as in all the other cutting methods, according to the equation below:

$$t_h = \frac{L}{v_f}$$

- | | | |
|-------|-----------|------------|
| L | in mm | total path |
| v_f | in mm/min | feed rate |

10.6.1 Sawing with circular saw blade of rectangular section (Figure 10.8)

$$A = L \cdot B$$

A in mm² circumscribing rectangular surface

L in mm total path

B in mm material width (total width)

$$L = l_w + \frac{D}{2} - \frac{1}{2}\sqrt{D^2 - B^2}$$

l_w in mm material thickness in feed direction

D in mm saw blade diameter

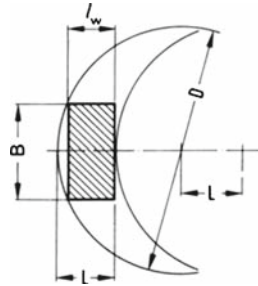


Figure 10.8
Total path L for circular sawing

Circular cross section (Figure 10.7)

$$A = d^2$$

$L = d; B = d; d$ in mm diameter of the material to be cut.

Here we may equate L and B with d .

$$A_s = f \cdot l \cdot n = v_f \cdot l = \frac{f \cdot l}{t}$$

$$v_f = f_z \cdot z_w \cdot n$$

$$v_f = \frac{A_s}{l}$$

v_f in mm/min feed rate

f_z in mm feed per tooth

z_w number of teeth on the saw blade

n in min⁻¹ rotational speed of the saw blade or number of travels per minute

f in mm feed per revolution $f = f_z \cdot z_w$ or per stroke

t in min time per stroke or per revolution

The values for v_f or A_s can be taken from Table 10.17.

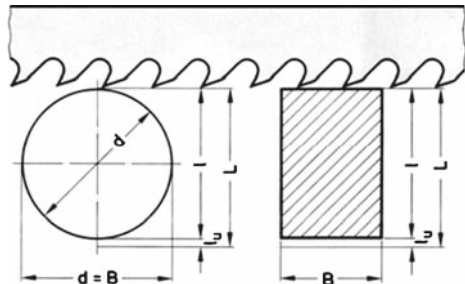


Figure 10.9
Total path L at band saws

10.6.2 Sawing with saw blade or saw band

$$A = L \cdot B$$

A	in mm ²	circumscribing rectangular surface
L	in mm	total path
B	in mm	total width
l_u	in mm	overrun
d	in mm	workpiece diameter = B
l	in mm	workpiece length in feed direction

$$L = l + l_u = d + l_u$$

The v_f and A_s values can be read from Table 10.15.

10.7 Sawing tools

10.7.1 Angles and pitch for saw tooth

The size of the angles is defined by the shape of the saw blade (Figure 10.10). Among the three angles that form the wedge angle, the clearance angle α is the most significant for the formation of the chip space. Chip space increases as a function of the clearance angle.

The wedge angle β is responsible for saw tooth stability. Consequently, hard and tough materials require a large wedge angle.

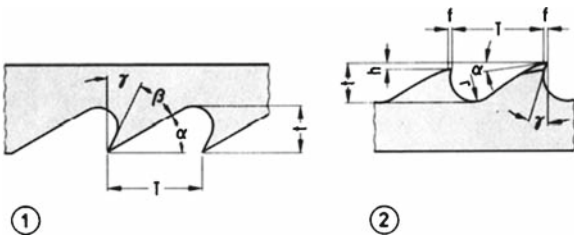


Figure 10.10
 Angles and pitch for saw tooth; 1 band saw blade; 2 circular saw blade; clearance angle; wedge angle; rake angle; T pitch; t tooth depth ($t = 0,4 T$)

Since major cutting force in sawing diminishes as the rake angle γ increases, positive rake angles are used for the most part.

Pitch T affects the chip space. The greater the pitch is, the greater the chip space and the easier the chip removal. If the pitch is too low, on the one hand, then chip space fills up, and the tooth, which is clogged with the chips, can no longer cut. The tooth is dragged over the workpiece and slightly grinds it slightly; thus, it is subjected to premature wear.

On the other hand, the pitch must not be too large; if it is, the teeth break off.

As a general rule, we may postulate that:

Four teeth should be in contact with the material's cross section, at a minimum (in the case of hard materials – more than 4 teeth are needed; for soft materials, 3 teeth might be sufficient).

When sawing profiled material, the thinnest profile cross section is decisive. At minimal cross section, 3 teeth should be engaged for minimum.

10.7.2 Sawing tools - tooth forms and design types

The term tooth form describes the contour of the tooth's cutting edge and the tooth gullet. The choice of the appropriate tooth form in each case strongly depends on the material to be cut and its size.

10.7.2.1 Saw blades

Teeth geometries of the saw blades for the hacksaws approximately correspond to the shapes for metal belt-saw blades shown in Figure 10.12.

The design type forms (lightweight or heavy), size and saw pitch T of the metal saw blades are defined in DIN 6495. Figure 10.11 illustrates a saw blade for a hacksaw machine.

Sizes and saw pitch of these saw blades are shown in Table 10.2.

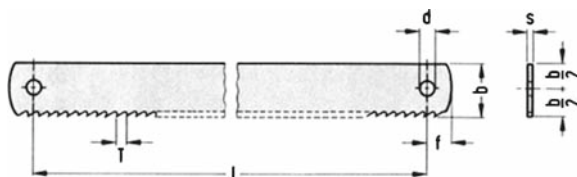


Figure 10.11
Metal saw blade for hacksaw machine

Table 10.2 Size and saw pitch of metal saw blades for hacksaw machine (excerpt from DIN 6495)

Shape	l in mm	b in mm	s in mm	Saw pitch T in mm			
<i>A</i> Light-weight	300	20	0,8	–	1,18	1,8	–
<i>B</i> Heavy	355	30	1,5	2,5	3,15	4,0	6,3
	500	40	2,0	2,5	3,15	4,0	6,3
	600	50	2,5	3,15	4,0	6,3	8,0

Denomination of a saw blade type *B*, length $l = 500$ mm, saw pitch $T = 4$ mm:
saw blade *B* 500 × 4 DIN 6495

10.7.2.2 Saw bands

Tooth forms

The tooth forms for saw bands consist of 4 basic types according to Figure 10.12.

The selection of the appropriate tooth form depends on the material to be cut. Saw pitch has to be adapted to thickness of the cut.

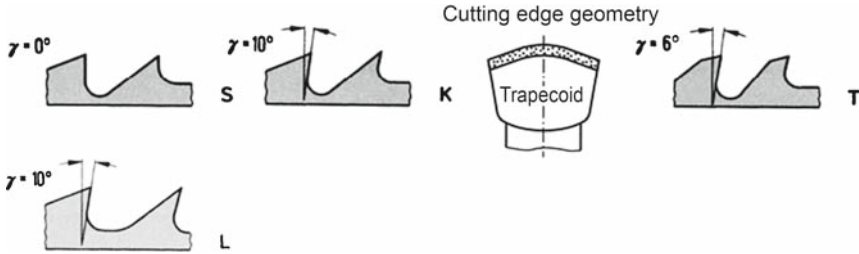


Figure 10.12

Tooth forms of metal band saw blades; *S* standard tooth; *K* claw tooth; *T* trapezoidal tooth; *L* space tooth

Length of contact is to be understood as the workpiece length over which - in the cutting direction – the saw band is engaged. It thus follows that shorter contact lengths require fine teeth, which means that a short saw pitch is called for.

The most essential ranges of application, rake angle and pitch regions of the tooth forms are shown in Table 10.3.

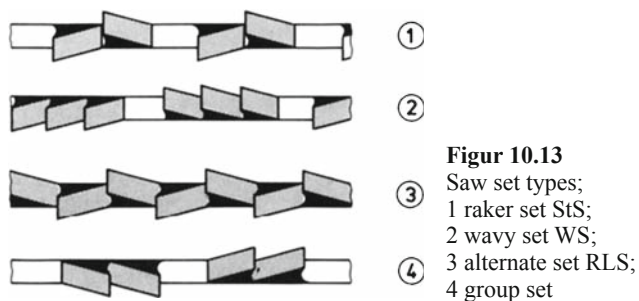
Table 10.3 Ranges of application of tooth forms in metal band saw blades

Tooth form	Range of application	Rake angle	Pitch T_z ZpZ	
			const.	var.
Standard tooth S	For universal purposes, for grey cast iron, cast steel, steel, bronze, red brass, brass and brittle plastics	0	3–32	3–4 to 10–14
Claw tooth K	For the highest metal removal rates and easy-to-cut materials C steels, alloyed tool steels with low C content, stainless steels titanium, aluminium, brass and copper	+ 10	0,75–6	0,75–1,25 to 4–6
Space tooth L	For brittle materials such as grey cast iron, Al- alloys, Rg, Zn, Ms and large material cross sections	0	2, 3, 4 and 6	–
Trapezoidal tooth T	Trapezoidal tooth (T) with broadened tooth cutting edge and positive rake angle. Tooth form takes the place of saw set and is only produced for saw blades tipped with cemented carbide.	6	0,75–4	0,75–1,25 to 3–4

Saw pitch T_z describes the number of teeth per inch. In so-called WIKUS bands, we distinguish between constant saw pitch (const.) with standardised tooth spacing and variable saw pitch (var.) with differing tooth spacing within a tooth interval. Variable dimension figures are identified by 2 figures, e.g. 2–3 ZpZ. The name 2 ZpZ marks the maximal, and figure 3 the minimal distance in the tooth interval.

Band saw set

Saw set refers to the sidewise bowing out of teeth. Saw set (Figure 10.13) allows the saw band to move through the cut more easily.



Figur 10.13
Saw set types;
1 raker set StS;
2 wavy set WS;
3 alternate set RLS;
4 group set

Table 10.5 Set types - ranges of applications for metal band saw blades (excerpt from company documentation by WIKUS, Spangenberg)

Set type	Range of application
Raker set StS	For steel, grey cast iron and harder non-ferrous metals starting at 5 mm thickness of cut material
Wavy set WS	For thin material and low wall thickness values like sheet metal, thin-walled tubes and profiles
Alternate set RLS	For easy- to-cut materials such as non-ferrous metals, plastics
Group set GS	To cut tubes and profiles (GS set allows sawing with almost no vibrations)

Bi-metal saw bands

A Bi-metal saw band (Figure 10.14) consists of a carrier band made of a specially alloyed spring-steel cross band, in which a highly tough tempering structure is made through overheating in welding. The thickness of the high speed steel strip varies – as a function of the tooth form – from 1.0 to 2.3 mm. In large- toothed machine saw blades for hacksaws, the thickness of the high speed steel strip is 5 to 6 mm.

High speed steel	G	W %		Mo %		V %		Co %	Tooth hardness
M42	II	2	–	10	–	1	–	8	66–68 HRC
M51	III	10	–	4	–	3	–	10	66–68 HRC
Matrix 2	I	1	–	5	–	1	–	5	67–68 HRC

High speed steel materials for crests of teeth

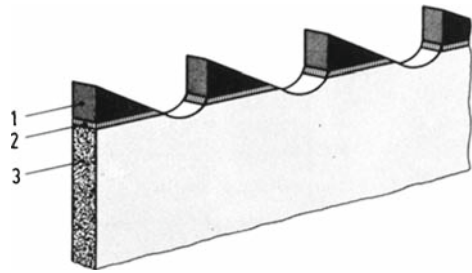


Figure 10.14

Bi-metal saw band.

1 high speed steel material;
2 welding joint; 3 carrier band

The materials are joined together by electron beam welding. Bi-metal saw bands like these allow substantially higher cutting speeds than exclusively steel bands made of tungsten alloyed material.

Carbide tipped saw bands

In carbide tipped saw bands, the cemented carbide teeth are mounted (captured) onto the carrier band with a special method designed by the firm WIKUS. The tooth forms S and K make it possible to fulfil even the most difficult requirements of metal cutting.

Table 10.6 Band dimensions and widths of cut for band saw blades (excerpt from company documentation by WIKUS, Spangenberg)

Size		Width of cut in mm
Width in mm	Thickness in mm	
13	0,8	1,0
20	0,85	1,1
27	0,9	1,2
34	1,1	1,4
54	1,3	1,8

The band width values of scroll saws range from 3 to 13 mm.

10.7.2.3 Circular saw blades

Tooth forms

The tooth forms (Figure 10.15) for circular saw blades are defined in DIN 1840. In this group, we distinguish between herringbone tooth, round back tooth and round back tooth with nicker and follower.

Saw pitch

The saw pitch to be selected depends on the size of the material to be sawn. Some reference values are summarised in the Table below.

Table 10.7 Saw pitch in circular saw blades

Size in mm	Full material				Profiles and tubes		
	to 6	> 6–20	> 20–50	> 50	to 3	> 3–6	> 6
Saw pitch <i>T</i> in mm	4	6	8	10–16	3–4	6	8

Saw blade type

In the case of circular saw blades explained in DIN 1837 and 1838, 3 tool types are mentioned. The denominations N, H and W define the range of applications of these circular saw blades.

Type N: for mild steels, grey cast iron and non-ferrous metals

Type H: for tough and semi-rigid materials

Type W: for soft and tough materials

Tooth forms

Name	Image	Symbol
Herringbone tooth		A
Herringbone tooth bent in alternate directions		Aw
Round back tooth		B
Round back tooth bent in alternate directions		Bw
Round back tooth with nicker and follower		C

Figure 10.15
Tooth forms for circular saw blades (excerpt from DIN 1840)

Table 10.8 Materials and corresponding tool type (excerpt from DIN 1836)

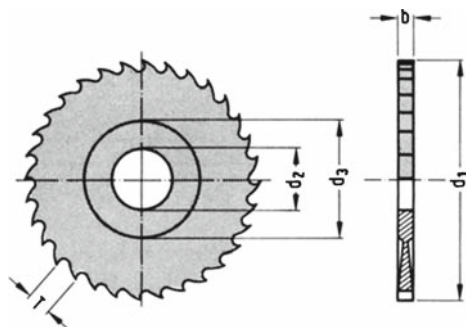
Material	Tool type		
S 275 JR C 15–C 22	N		(W)
E 295–E 335 C 35–C 45	N		
E 360 C 60	N	(H)	
Tool- and tempered steels e.g. 16 MnCr 5, 30 Mn 5		H	
GE 200–GE 260	N	(H)	
GJL 100–GJL 200	N		
GJL 250–GJL 300		H	

Design types of circular saw blades according to DIN 1837/38

For small diameters up to 315 mm, circular saw blades are manufactured as full steel blades, whereas at greater diameters they are assembled as segment blades.

Size, pitch and tooth number of the circular saw blades up to 315 mm \varnothing (Figure 10.16) are specified in DIN 1837 (fine toothed) and DIN 1838 (coarse toothed).

Excerpts from both of these DIN sheets are shown in Table 10.9.

**Figure 10.16**
Circular saw blade according to DIN 1837/38**Table 10.9** Sizes of full steel-circular saw blades (excerpt from DIN 1837/38)

	DIN 1837					DIN 1838								
	d_1		d_2		d_3	b		T		z		T		Z
d_1	20	50	63	100	160	315								
d_2	5	13	16	22	32	40								
d_3	10	25	32	40	63	80								
b	T	z	T	z	T	z	T	z	T	z	T	z	T	Z
0,5	1,25	48	1,6	100	3,15	64	—	—	—	—	—	—	—	—
1	1,6	40	2	80	4	48	5	64	6,3	80	—	—	—	—
3	2	32	3,15	48	6,3	32	8	40	8,0	64	10	100	—	—
6	2,5	24	4	40	8	24	10	32	10,0	48	12,5	80	—	—

Consequently, a coarse toothed metal saw blade with $d_1 = 160$ mm, $b = 3$ mm, tooth form B, tool type N, made of high speed steel (see Figure 10.16) is described as follows:

“Circular saw blade 160 × 3 BN DIN 1838 – high speed steel”

For these circular saw blades, the rake angles are a function of tooth form and tool type.

Table 10.10 Rake angle of circular saw blades according to DIN 1837 and 1838

Tooth form	Rake angle $\gamma \pm 2^\circ$		
	Type N	Type H	Type W
herringbone tooth A	5	0	10
round back tooth B	15	8	25
round back tooth C	15	8	25

Large circular saw blades are mostly made as segment saw blades (Figure 10.17). In these saw blades, the master blade is made of tool steel, but the segment (Figure 10.18) of high speed steel.

There are also segments with inserted cemented carbide cutting edges. Either the cold-hammered bottom part of the segments grips the web of the master blade or the web of the segment engages into the groove of the master blade (Figure 10.19). These segments are attached to the master blade with 4 rivets. The tooth form is illustrated in Figure 10.20.

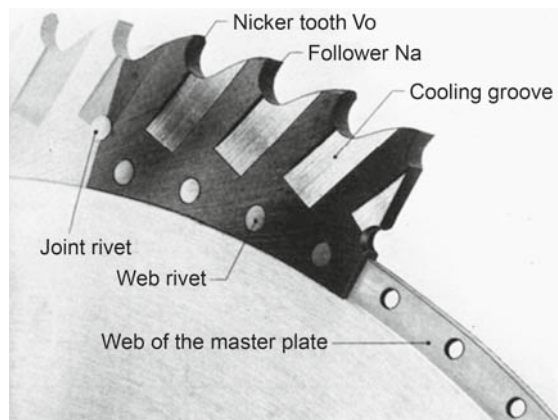


Figure 10.17
Segmented circular saw blade (photo by J. W. Arntz, Werkzeugfabrik, Remscheid)

We can see that the teeth are formed to function alternately as nicker Vo and follower Na.

The nicker is slanted on both sides by $\frac{1}{3}$ of tooth width B to 45° . The nicker cuts into the depth.

Figure 10.18
Segment of a segment circular saw blade, individual segment consisting of 5 teeth
(photo by Arntz, Remscheid)

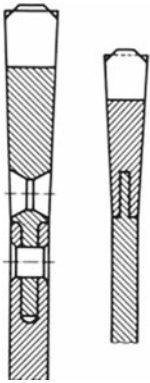
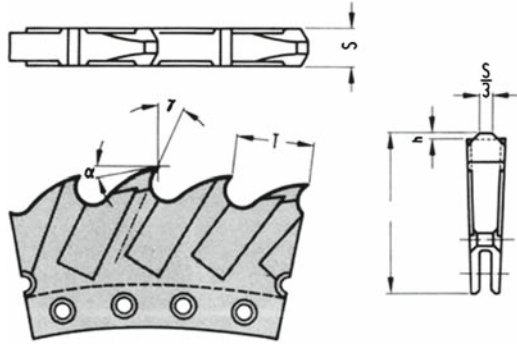
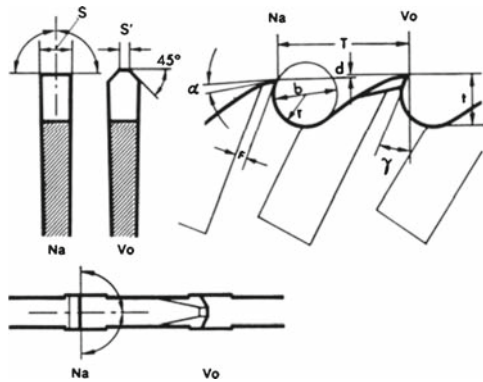


Figure 10.19
Attaching the segment to the master blade
(either master blade or slotted segment)

Figure 10.20
Tooth form for segmented saw blades
Vo nicker tooth
Na follower
F chamfer of clearance angle
S width of cut
S' nicker width
($S' = S/3 - h$)



The follower, which affects the full width, is deeper than the nicker; it is lowered by value h . The rounding of the tooth space allows the chip to easily flow in a helical manner.

The dimensions of a tooth system like this are shown in Table 10.11.

The sizes of the segmented circular saw blades are defined in DIN 8576.

Table 10.11 Saw pitch and tooth depth for segmented saw blades according to DIN 8576 (excerpt from company documentation for Th. Flamme, Fulda)

Saw pitch T in mm	6	7	8	9	10	12	14	16	18	20	22	24	26	28	30	32	34	36	38	40
Tooth depth t in mm	2,4	2,8	3,2	3,6	4	4,8	5,6	6,4	7,2	8	8,8	9,6	10,4	11,2	12	12,8	13,6	14,4	15,2	16
Round- ing d in mm	3	3,5	4	4,5	5	6	7	8	9	10	11	12	13	14	15	16	17	18	19	20
Differ- ence in height h in mm	0,2			0,3						0,4						0,5				

Table 10.12 Sizes of segmented saw blades (excerpt from DIN 8576)

outer diameter in mm	250	315	400	500	630	800	1000	1250	1600
hole diameter in mm	32	40	50	50	80	80	100	100	100
width of cut in mm	4,0	4,5	5,0	5,6	6,3	7,0	8,0	9,0	12,6
blade thickness in mm	3,0	3,5	3,8	3,8	4,5	5,0	6,0	7,0	10,5

10.7.3 Saw blade materials

For the blades of all three saw types, including

- saw blades for hacksaws
- saw belts for band saws
- circular saw blades for circular saws,

both

- tool steel and
- high speed steel

are used as cutting material.

Saw blades for hacksaws and saw belts for band saws are predominantly made of tool steel.

For greater efficiency, tool steel is alloyed with 1,8 to 3% tungsten.

Research and development in the field of bi-metal tools for saw blades and saw bands, in which spring steel is used as the carrier material, and only the cutting edges are made of high speed steel, have yielded high performance tools that allow high cutting speeds even for saw bands.

The preferred material for circular saw blades is high speed steel. Therefore, the material S 6-5-2, material No. 1.3343 is used in most cases.

8–9% cobalt-alloyed high speed steels, or high speed steels with slightly lower cobalt content, but additions of tungsten and chromium, have been used recently for the most demanding requirements.

In the case of large saw blades, the master blade, to which segments made of high speed steel are added, consists of tool steel.

However, it is also possible to equip these segments with cemented carbide cutting edges. To do this, the cemented carbide type P 25, and, in some cases P 40, is used. In this way, it is possible to achieve cutting speeds of 70–180 m/min at feed per tooth values of 0,1 to 0,3 mm.

At present, cemented carbide is relatively rarely used for sawing tools because the application of such cemented carbide segments, due to their high cutting speeds, demands about 10-times more power than high speed steel tools and most sawing machines are not yet able to meet this requirement.

10.8 Failures in sawing

Table 10.13.1 Failures in sawing with a hacksaw

Consequences for the tool	Reason for the failure	Remedy
Blade breaks in the hole	Tension of saw blade too high	Reduce blade tension
Blade breaks	Incorrect placement of the saw blade at the start of cut	Do not start in existing cut
	Blade tension too low	Retighten blade
	Cutting pressure too high	Reduce cutting pressure
	Workpiece insufficiently stable	Retighten workpiece
Premature wear on the saw blade	Too high cutting speed or too high cutting pressure	Reduce cutting speed or cutting pressure
	Bow of the saw does not lift off during the idle travel	Check machine
	Incorrect saw pitch	Select other pitch
	Missing coolant	Install correct coolant
Breaking off of teeth	Placed at sharp edge	Carefully position blade when starting the cut
	Saw pitch too high	Select other pitch
Diagonal cut	Too low tension blade dull too high cutting pressure	Retighten blade exchange saw blade reduce cutting pressure

Table 10.13.2 Failures in sawing with band saws

Consequence for the tool	Reason for failure	Remedy
Teeth become dull too quickly	Cutting speed too high	Lower cutting speed
Teeth break off when cutting off profile material	Too high saw pitch	Select other pitch
	Too high lowering rotational speed of the saw frame	Reduce feed rate
	Workpiece not held tightly enough	Reclamp workpiece
Teeth break out when parting off solid material	Material not annealed	Use coarser teeth, increase cutting speed and reduce cutting pressure use wavy- or group saw set
	Saw pitch too fine	Select greater pitch
	Workpiece not held tightly enough	Reclamp workpiece
Band breaks in the welding joint	Band guidance positioned incorrectly	Readjust guidance
Band breaks	Guide rollers are positioned too close together and roll off the belt	Readjust guidance
	Incorrect guide rollers (conical or convex)	Replace guide rollers
Saw band accelerates during sawing	Too high cutting speed	Reduce cutting speed
Diagonal cut	Teeth too coarse or cutting pressure too high or saw band dull	Select other teeth diminish cutting pressure use new band

Table 10.13.3 Failures in sawing with circular saws

Consequences for the tool	Reason for the failure	Remedy
Blade breaks	Wrong start at first cut	At the beginning of the cut, blade must not lie on the material
	Dull circular saw blade	Resharpen blade
Teeth break off	Poor chip removal as a result of too short a saw pitch	Select longer saw pitch
	Teeth hook in material	Select shorter saw pitch
	Workpiece clamped too loosely in the vice	Reclamp workpiece

Table 10.13.3 Failures in sawing with circular saws

Teeth become dull too quickly	Tooth gullet crowded with chips, teeth clog	Select longer saw pitch
	Inexact cut	Select shorter saw pitch and reduce cutting pressure
	Missing or inadequate coolants	Use appropriate coolants
Jamming and adhesion of material to the saw blade	Wrong feed	Increase or diminish feed
	Missing or inadequate coolants	Use appropriate coolants

10.9 Reference tables

Table 10.14 Selection of tooth form and saw pitch (number of teeth on a length of 25 mm) for band saws

Workpiece	Size of the workpiece to be sawn, in mm						
	Up to 2	3–10	11–25	26–50	51–80	81–120	> 120
S 275 JR C 15–C 22	24 S	18 S	10 S	8 S	6 S/K	4 K	3 K
E 295–E 335 C 35–C 45	24 S	18 S	14 S	8 S	6 S	4 S	3 L
E 360 C 60	24 S	24 S	14 S	10 S	8 S	6 S	4 S
16 MnCr 5 30 Mn 5	24 S	18 S	10 S	8 S	6 S	4 K/S	3 K/L
GE 200–GE 260	–	14 S	10 S	8 S	6 S/D	4 S/L	3 L/D
GJL 150–GJL 300	–	14 S	10 S	8 S	6 S/D	4 S/L	3 L/D
CuZn 37–CuZn 30	24 S	14 S	10 S	6 S/K	4 K	3 K	3 K
AW-AL 99,5	14 S	8 S	6 K	4 K	3 K	3 K	3 K
Al alloy 9–13% Si	18 S	10 S	8 S	6 K	4 K	3 K	3 K

(excerpt from reference tables by Th. Flamme, Fulda)

S = standard tooth, K = claw tooth, L = space tooth, D = roof tooth

Example: material St 42, workpiece diameter 50 mm to be selected: pitch $T = 8$ teeth per 25 mm length, tooth form S

Table 10.15 Cutting speeds v_c in m/min, feed rates v_f in mm/min and specific area of cut A_s in 10^3 mm²/min for band saws

Material	Tool material tool steel with 3% W		Tool material high speed steel bi-metal bands		
	v_c in m/min	A_s in 10^3 mm ² /min	v_c in m/min	A_s in 10^3 mm ² /min	v_f in mm/min
S 275 JR C 15–C 22	40–50	6	70–80	7–8	30–50
E 295–E 335 C 35–C 45	40–45	5	60–70	6–7	30–50
E 360 C 60	20–30	4	60–70	5–6	20–40
16 MnCr 5 30 Mn 5	30–35	4	50–60	5–6	15–22
GE 200–GE 260	25–30	4	40–50	5–6	20–40
GJL 200– GJL 300	30–40	3	50–70	4–5	30–45
CuZn 37–CuZn 30	80–120	25–30	250–350	35–40	300–400
Al alloy 9–13% Si	60–70	40–70	80–100	50–80	450–800

(excerpt from reference tables by Th. Flamme, Fulda and the firm Forte, Winterbach)
bi-metal bands have high speed steel cutting edges, mat-No. 1.3343 with 5% Mo, W and Cr additions






Ex.: What specific area of cut A_s should be chosen for a bi-metal band, if material St 50 is to be sawn?

Approach: $A_s = 6000$ to 7000 mm²/min

Take into account that:

$$v_f = \frac{A_s}{l} \quad \text{und} \quad f_z = \frac{v_f}{z_w \cdot n} \quad (\text{compare 10.6})$$

Table 10.16 Saw pitch T in mm, as a function of the material to be sawn, workpiece geometry and -diameter D in mm for segment circular saw blades

Material and shape	Workpiece diameter D in mm													
	20	30	40	50	60	70	80	90	100	150	200	250	300	400
 Light metal, copper, Cast steel S 185–E 360 C 15...C 60 15 Cr 3, 15 CrNi 6, 18 CrNi 8, 16 MnCr 5 20 MnCr 5, 25 CrMo 4 50 CrMo 4, 34 CrNiMo 6 stainless steels	10	12	14	16	18	18	20	20	22	26	30	35	38	44
 Brass Bronze GG 150–GG 220 Alloyed tool steels High speed steels	8	10	12	12	14	14	16	16	18	22	24	26	28	34
 Thick-walled tubes $\delta = 0,1 D$  Profile steel	6	6	8	8	10	10	10	12	12	14	16	18	20	22
 Tubes with standard wall thickness $\delta = 0,05 D$	4	6	6	6	8	8	8	10	10	12	14	14	16	18

(excerpt from reference tables by Wagner Reutlingen)

Table 10.17 Cutting speeds v in m/min, feed rates u in mm/min, specific area of cut A_s in 10^3 mm²/min and tool angle for segmented circular saw blades (high speed steel) (excerpt from reference tables by Th. Flamme, Fulda)

Material	v in m/min	u in mm/min	A_s in 10^3 mm ² /min	Tool angles	
				$\alpha \pm 1^\circ$	$\gamma \pm 1^\circ$
E 295 C 15–C 22	25–30	80–150	12–20	8	22
E 295–E 335 C 35–C 45	20–28	70–120	10–14	8	20
E 360 C 60	20–22	50–80	8–12	7	18
16 MnCr 5 30 Mn 5	12–15	50–90	8–12	6	15
GE 200–GE 260	15–20	70–100	10–12	8	20
GJL 200– GJL 300	17–20	80–110	8–10	6	12
CuZn 37–CuZn 30	200–600	800–1100	48–70	10	20
Al alloy 9–13% Si	300–600	1200–2200	80–200	12	30
Profiles made of steel DIN 1024	25–30	70–130	8–15	8	20

$$v_f = f_z \cdot z_w \cdot n$$

V_f in mm/min
 f in mm feed

feed rate
per tooth
number of teeth on the saw blade
rotational speed of the saw blade

$$v_f = \frac{A_s}{l}$$

z_w
 n in min⁻¹

10.10 Examples

Example 1

Material E 295, diameter 180 mm, is to be sawn on a circular saw. Saw blade diameter of the segmented circular saw blade (high speed steel) is 630 mm. The efficiency of the circular saw is assumed to be 0,8.

Sought for:

- major cutting force for engaged teeth
- machine input power
- machining time for one cut

Approach:

1. Select saw pitch T from Table 60
 $T = 28 \text{ mm}$ selected

2. Number of teeth on the saw blade

$$z_w = \frac{D \cdot \pi}{T} = \frac{630 \cdot \pi \text{ mm}}{28 \text{ mm}} = 70,68$$

$$z = 70 \text{ teeth selected}$$

The manufacturer determines the number of teeth on the circular saw blade based on predefined pitch. Here the author only wishes to explain how to determine it in principle.

3. Take A_s and v_c for St 50 from Table 10.17.

$$\text{Use } A_s = 12000 \text{ mm}^2/\text{min}, \quad v_c = 24 \text{ m/min}$$

4. Contact length

$$l = \frac{\pi \cdot D \cdot \varphi_s^\circ}{360} = \frac{\pi \cdot 630 \text{ mm} \cdot 33^\circ}{360^\circ} = 181 \text{ mm}$$

$l \approx d$, since $D \gg d$, consequently continue with $l = d$

5. Feed per tooth

$$f_z = \frac{A_s \cdot D \cdot \pi}{l \cdot v_c \cdot z \cdot 10^3 \text{ mm/m}} = \frac{12 \cdot 10^3 \text{ mm}^2/\text{min} \cdot 630 \text{ mm} \cdot \pi}{180 \text{ mm} \cdot 24 \text{ m/min} \cdot 70 \cdot 10^3 \text{ mm/m}} = 0,0785 \text{ mm/tooth}$$

6. Number of teeth in contact

$$z_E = \frac{\varphi_s^\circ \cdot z}{360^\circ} = \frac{33^\circ \cdot 70}{380} \qquad \sin \frac{\text{NR}}{\frac{\varphi_s}{2}} = \frac{B}{D} = \frac{d}{D} = \frac{180 \text{ mm}}{630 \text{ mm}}$$

$$z_E = 6,41 \text{ teeth}$$

$$\sin \frac{\varphi_s}{2} = 0,285$$

$$\frac{\varphi_s}{2} = 16,5^\circ; \quad \varphi_s = 33^\circ$$

z_E must not be rounded – value only for calculation

7. *Specific cutting force*

$$k_{ch} = \frac{(1 \text{ mm})^z \cdot k_{c1,1}}{h^z} = \frac{(1 \text{ mm})^z \cdot k_{c1,1}}{f_z^z}$$

$$k_{ch} = \frac{(1 \text{ mm})^{0,26} \cdot 1990 \text{ N/mm}^2}{(0,0785 \text{ mm})^{0,26}} = 3856,4 \text{ N/mm}^2$$

$$k_c = k_{ch} \cdot K_v \cdot K_{ver} \cdot K_{st}$$

$$k_c = 3856,4 \text{ N/mm}^2 \cdot 1,15 \cdot 1,2 \cdot 1,3 = 6918,4 \text{ N/mm}^2$$

8. Major cutting force for teeth in contact

$$F_c = a_p \cdot f_z \cdot k_c \cdot z_E$$

width of cut $a_p = 6,3 \text{ mm}$, to be taken from Table 10.12.

$$F_c = 6,3 \text{ mm} \cdot 0,0785 \text{ mm} \cdot 6918,4 \text{ N/mm}^2 \cdot 6,41$$

$$F_c = 21931,7 \text{ N}$$

9. Machine input power

$$P = \frac{F_c \cdot v_c}{10^3 \text{ W/kW} \cdot 60 \text{ s/min} \cdot \eta_M} = \frac{21931,7 \text{ N} \cdot 24 \text{ m/min}}{10^3 \text{ W/kW} \cdot 60 \text{ s/min} \cdot 0,8} = 11 \text{ kW}$$

10. Machining time

$$t_h = \frac{A}{A_s} = \frac{d^2}{A_s} = \frac{180^2 \text{ mm}^2}{12 \cdot 10^3 \text{ mm}^2/\text{min}} = 2,7 \text{ min}$$

or:

$$t_h = \frac{L}{v_f} \quad \text{with } L = d$$

$$v_f = f_z \cdot z_w \cdot n$$

$$n = \frac{v}{d \cdot \pi} = \frac{24 \cdot 10^3 \text{ mm/min}}{630 \cdot \pi \text{ mm}}$$

$$n = 12 \text{ min}^{-1}$$

$$v_f = 0,0785 \text{ mm} \cdot 70 \cdot 12 \text{ min}^{-1}$$

$$v_f = 66 \text{ mm/min}$$

$$t_h = \frac{180 \text{ mm}}{66 \text{ mm/min}} = 2,7 \text{ min}$$

Example 2:

When parting off solid material, diameter 100 mm, with a band saw, teeth on the saw band break off.

Please describe why the teeth break off!

Approach:

see Table 10.13.3!

11 Milling

11.1 Definition

Milling is defined as a metal cutting technology in which a multi-edged tool removes the metal.

During milling, the tool performs the cutting motion, whereas the workpiece (that is, the milling machine table on which the workpiece is mounted) executes the feed motion. The milling techniques are defined according to the tool axis position relative to the workpiece and according to the tool denomination.

11.2 Milling techniques

11.2.1 Peripheral milling

Peripheral milling is a milling method which functions with horizontal tool axis. The cutting edges of the plain milling cutter are located at the tool's periphery. Peripheral milling is subdivided into up- and down milling.

11.2.1.1 Up milling

During up milling (Figure 11.1), the milling cutter rotates in a direction opposite to the feed direction of the workpiece. The feed motion direction (Figure 11.2) is characterised by the feed motion angle φ . If, over the course of a single tooth's contact with the material (from the moment the tooth comes into contact with the material – tool entry - up to tool exit), φ remains less than 90° , then it is an up milling procedure. During up milling, workpiece material is removed by the resultant force. There is the risk that the workpiece may be pulled out of the mounting or that the milling table will buckle. Specially designed clamping jigs and undercuts in the table guide-ways avoid damage to the workpiece or tool.

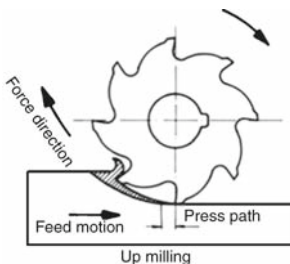


Figure 11.1
Up milling principle, inserted force direction relates to the workpiece

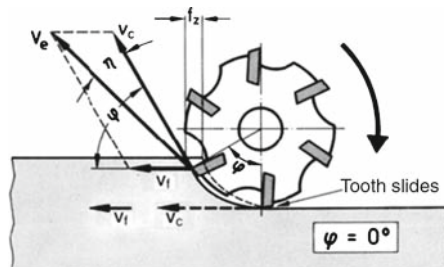


Figure 11.2
Feed motion angle φ during peripheral milling in the up milling mode ($\varphi < 90^\circ$), illustrated velocities relate to the tool, v_c effective cutting speed (photo by Sitzmann and Heinlein)

11.2.1.2 Down milling

During down milling (Figure 11.3), the direction of milling cutter rotation is the same as the workpiece's feed direction. The milling cutter approaches from the thickest part position of the chip. In down milling, the feed motion angle φ (Figure 11.4) ranges from 90° to 180° . The resultant force presses the workpiece against the base. In cases where the cutter arbour is insufficiently stiff, the milling cutter "climbs" onto the workpiece, and cutting edges break off.

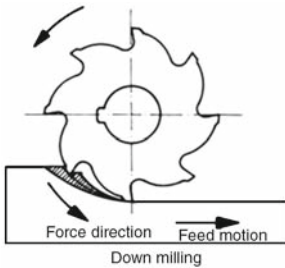


Figure 11.3
Down milling principle, marked force direction is related to the workpiece

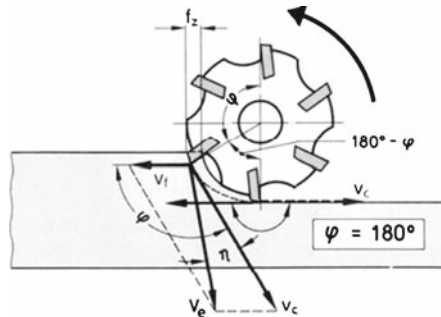


Figure 11.4
Feed motion angle φ during peripheral milling in the down milling mode ($\varphi > 90^\circ$), recorded velocities relate to the tool

During down milling the resultant force direction coincides with the feed motion direction. Thus, if the feed screw experiences backlash, the resultant force makes the lead-bearing flank at the feed screw changes at each start of the cut. Milling machines for down milling should have a feed drive with no backlash, cutter arbours and frame components of high stiffness.

11.2.2 Face milling

In face milling the tool axis is orthogonal to the surface to be generated. However, in face milling, the tool does not only cut with its face, as the name of the method indicates, but, as in peripheral milling, removes metal primarily with the peripheral cutting edges. The face cutting edges act as secondary cutting edges and smooth the milled surface (Figure 11.5). As a result, face milled surfaces have a high surface quality.

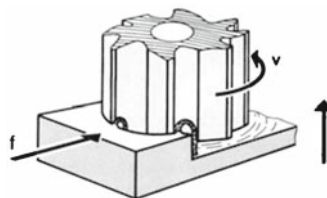


Figure 11.5
Face milling principle

During face milling, down- and up milling procedures are carried out alternately. At the beginning of the cutting procedure, the direction of rotation is opposite to the feed direction of the workpiece. However, starting from the middle of the workpiece (Figure 11.6), the procedure merges into down milling. Alternate metal cutting by down- and up milling is able to compensate as much as possible for deviations of the cutting force and thus to relieve the cutting edges of load. Consequently face milling allows for high metal removal rates.

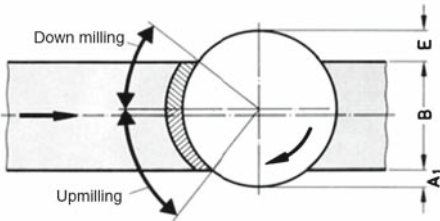


Figure 11.6
Alternate down- and up milling during face milling

If, during face milling, work is done with a feed motion angle $\varphi_A > 0$ (compare 11.5.2.1.), then, when starting the cut, sufficient sectional areas of the chip are available, and the blades of the mill clutch the chip at once and cut it off without first sliding.

11.2.3 Form milling

Form milling is the name for a milling procedure carried out with milling cutters whose shape corresponds to the finished contour to be generated (Figure 11.7). If it is impossible to generate a specific workpiece geometry with one cutter of the former type, then it is common practice to put together several milling cutters (Figure 11.8) in a set, called a gang cutter.

Form milling also implies thread milling, because milling cutters corresponding to the thread profile are used. The following tools are distinguished:

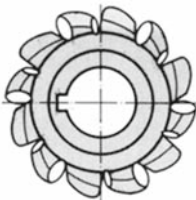


Figure 11.7
Semicircle cutter of the former type

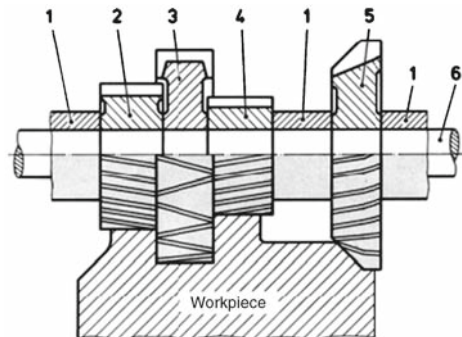


Figure 11.8
Gang cutter (with 6 elements), 1 spacing collars, 2 peripheral milling cutter, 3 staggered-tooth side and face milling cutter, 4 peripheral milling cutter, 5 angle cutter, 6 cutter arbour

Long-thread milling

In long-thread milling (Figure 11.9) a disk-shaped profile milling cutter (cutter of the former type) penetrates the workpiece.

The long-thread milling machine with feed gear system and lead screw generates the longitudinal feed of the milling cutter. Here the workpiece may rotate either in the same direction as or in the opposite direction from the milling cutter (down- or up milling).

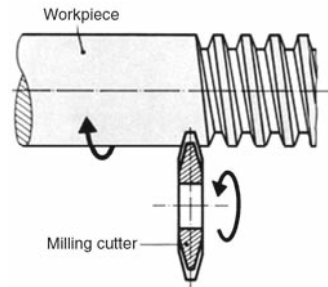


Figure 11.9

Tool- and workpiece configuration during long-thread milling

Short-thread milling

In short-thread milling (Figure 11.10), the roller-shaped milling cutter penetrates the workpiece to its full depth, whereas the workpiece rotates around 1/6 of its circumference. The thread to be milled is finished after 1/4 workpiece revolutions.

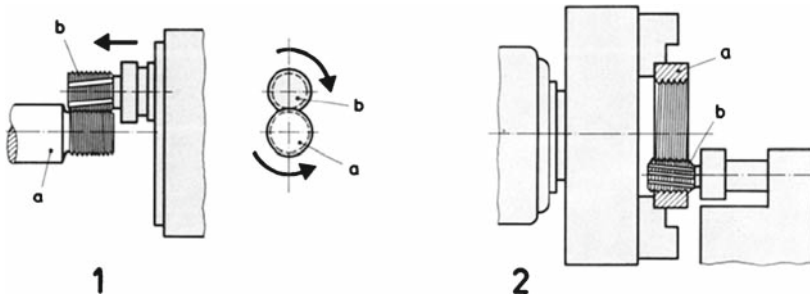


Figure 11.10

1 workpiece and tool configuration during short-thread milling of external threads
2 workpiece- and tool configuration during short-thread milling of internal threads.
a workpiece, b mill

11.2.4 Groove milling

Grooves are cut out with end milling cutters or side and face milling cutters. Depending on the procedure that takes place when generating a groove, these methods are classified as given below:

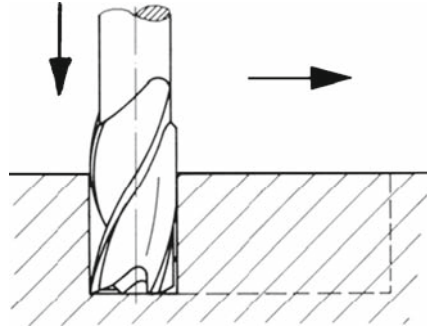


Figure 11.11
Plunge milling principle
1 mill to depth,
2 milling feed in longitudinal direction,
3 move out tool

11.2.4.1 Plunge milling to generate grooves

At the beginning of plunge milling (Figure 11.11), the end mill cutter cuts down to the full groove depth like a twist drill. Subsequently the whole length of the groove is machined in one cut. Due to the large depth of immersion of the mill, one can only set up small longitudinal feed values here.

11.2.4.2 Line milling to generate grooves

With this method, the depth of a groove is machined using stepwise metal removal line by line rather than in one step. The end mill cutter penetrates the workpiece only shallowly and then mills the groove to its full length. In the final position, the milling cutter cuts slightly deeper. Then it goes on milling the groove to its full length in the opposite feed direction.

This cycle is repeated until (Figure 11.12) the desired depth of groove is achieved. Due to the low downfeed in each step, in this technique, one can set up higher longitudinal feed values.

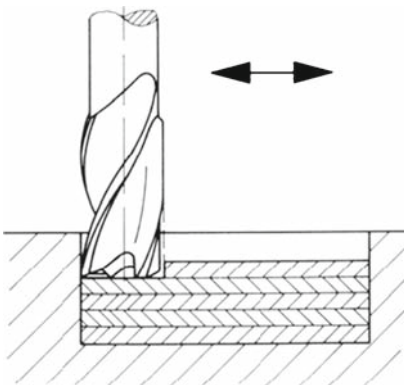


Figure 11.12
Principle of line milling to generate grooves

11.2.4.3 Groove milling with side and face milling cutter

Continuous or through going slots or grooves with a large exit (e.g. for multi-spline profiles) are mostly cut with a disk-shaped plain milling cutter. The chip metal

removal per unit of time is greater than that achieved with the methods described under 11.2.4.1 and 11.2.4.2.

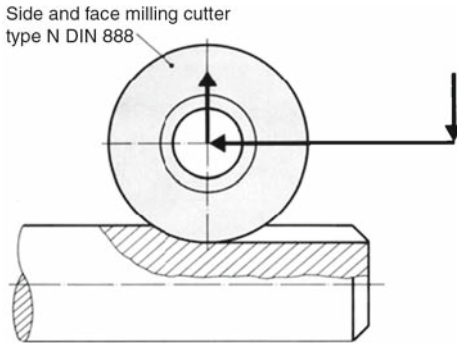


Figure 11.13
Principle of groove milling with side and face milling cutter

11.3 Application of the milling techniques

11.3.1 Peripheral milling

It is impossible to achieve excellent surface qualities due to the very disadvantageous cutting conditions (uneven sectional area of chip) during peripheral milling.

Consequently, peripheral milling is primarily used for cutting smaller surfaces and to shape profiles with the cutter gang (Figure 11.8).

Peripheral milling in conjunction with face milling is advantageously applied as face side milling even to create shouldered surfaces (Figure 11.14). When using machines with the appropriate design, down milling generates better surface qualities than up milling.

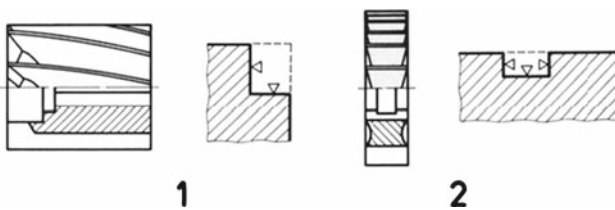


Figure 11.14

- 1 contour generated with shell end mill DIN 841
- 2 groove generated with side and face milling cutter

11.3.2 Face milling

Face milling is used to generate plane surfaces. In face milling, cutter heads tipped with inserted cemented carbide tips are used at present. A general rule of thumb holds that face milling takes priority over peripheral milling.

11.3.3 Form milling

Formed surfaces with specific contours like radiuses, prisms, angles for dovetail slides etc. are created with form milling. Gang cutters are applied to produce contours with different form profiles. Thread milling, long-thread milling with profile milling cutters and short-thread milling with profile-plain milling cutters are special form milling variants. Form milling can also be applied to mill toothed gears with the single pitch technique.

11.3.4 Groove milling

Groove milling is defined as a method to generate grooves limited in length; e.g. grooves for feather keys according to DIN 6885, or continuous grooves, e.g. of multi-splined profiles for splineshafts according to DIN 5461.

11.4 Accuracies achievable with milling

Method	Accuracy to size in mm	Surface quality during finishing (peak-to-valley height) R_t in μm
Peripheral milling	IT 8	30
Face milling	IT 6	10
Form milling	IT 7	20–30

11.5 Calculation of force and power

11.5.1 Peripheral milling

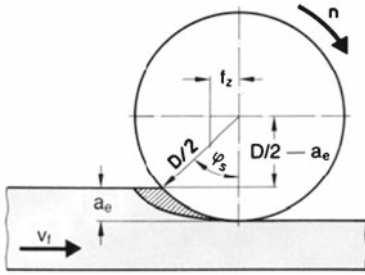
Side and face milling cutters are straight-toothed, helical or staggered-tooth. Wider plain milling cutters have cutting edges in slope position, characterised by helix angle λ (Figure 11.16).

11.5.1.1 Angle of approach

The angle of approach φ can be calculated from the depth of cut and the milling cutter diameter (Figure 11.15).

$$\cos \varphi_s = 1 - \frac{2 \cdot a_c}{D}$$

φ	in $^\circ$	angle of approach
a_c	in mm	depth of cut (working contact)
D	in mm	milling cutter diameter

**Figure 11.15**

Undeformed chip parameters during peripheral milling,

a_c depth of cut,

f_z feed per tooth

φ_s angle of approach,

D milling cutter diameter

11.5.1.2 Choice of the milling cutter diameter

For *peripheral* and *face* milling, the milling cutter diameter D is recommended to be approximately equal to the width of cut a_p .

$$D \approx a_p$$

D	in mm	milling diameter
B	in mm	milling cutter width (Figure 11.16)
a_p	in mm	width of cut

11.5.1.3 Milling cutter speed

$$n = \frac{v_c \cdot 10^3 \text{ mm/m}}{D \cdot \pi}$$

n	in min^{-1}	milling cutter speed
v_c	in m/min	cutting speed (to be taken from Table 71)
D	in mm	milling cutter diameter

11.5.1.4 Feed rate of the milling machine table

$$v_f = f_z \cdot z \cdot n$$

v_f	in mm/min	feed rate of the milling machine table
f_z	in mm	feed per cutting edge
z_w		number of cutting edges of the milling cutter
n	in min^{-1}	milling cutter speed

11.5.1.5 Width of cut

For straight-toothed mills:

$$b = a_p$$

For milling cutters with helix angle (compare Figure 11.16):

$$b = \frac{a_p}{\cos \lambda}$$

b in mm width of cut
 a_p in mm milling width (width of cut)
 λ helix angle

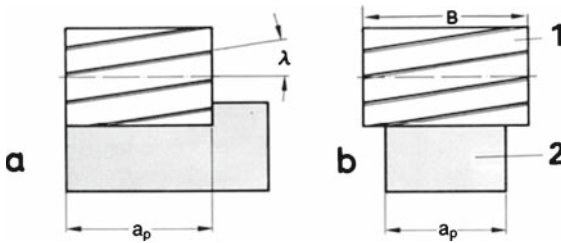


Figure 11.16

Width of cut a_p during peripheral milling, 1 milling cutter, 2 workpiece

Figure a: a_p defined by milling cutter width,

Figure b: a_p given by workpiece width

11.5.1.6 Average chip thickness (Figure 11.17)

During peripheral milling, chip thickness is variable, that is, it increases or decreases in feed direction. Chip thickness has its maximum f_z during the milling cutter blade entry (down milling) into or exit (up milling) out of the workpiece.

Consequently an average chip thickness is assumed during milling.

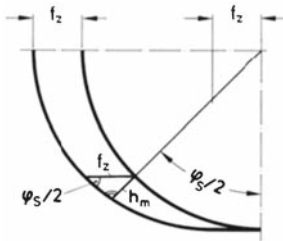


Figure 11.17

Average chip thickness h_m
 h_m is measured at $\varphi_s/2$

The size of h_m is related to the half angle of approach ($\varphi_s/2$). The chip thickness occurring at $\varphi_s/2$ is labeled the average chip thickness h_m . It can be determined according to the equation below:

$$h_m = \frac{360^\circ}{\pi \cdot \varphi_s} \cdot \frac{a_c}{D} \cdot f_z \cdot \sin \kappa$$

$\kappa = 90 - \lambda$ for helical mills; for side and face milling cutters, $\sin \kappa = 1$ and $360^\circ/\pi = 114,6^\circ$, it follows:

$$h_m = \frac{114,6}{\varphi_s} \cdot \frac{a_c}{D} \cdot f_z$$

h_m	in mm	average chip thickness
φ_s	in °	angle of approach
a_c	in mm	depth of cut
D	in mm	milling cutter diameter
f_z	in mm	feed per cutting edge

11.5.1.7 Specific cutting force

The specific cutting force is corrected by the factors K_γ , K_v , K_{ver} and K_{st} taking into account the influence of the rake angle, the cutting speed, the wear and the chip compression.

In the interest of simplicity, a 30% increase of k_c is assumed due to the wear that appears on the tool. But in practice this can be higher.

$$K_{ver} = 1,3$$

The influence of the cutting speed K_v is considered by the correction factor K_v .

For high speed steel tools
(milling cutters):

$$K_v = 1,2$$

For cemented carbide tools:

$$K_v = 1,0$$

Chip compression corresponds to internal turning

$$K_{st} = 1,2$$

The correction factor for the rake angle is given below:

$$K_\gamma = 1 - \frac{\gamma_{tat} - \gamma_0}{100}$$

K_γ correction factor for the rake angle

γ_{tat} in ° actual rake angle on the tool

γ_0 in ° base rake angle $\gamma_0 = 6^\circ$ for steel milling
 $\gamma_0 = 2^\circ$ for milling of castings

Specific cutting force

$$k_c = \frac{(1 \text{ mm})^z}{h_m^z} \cdot k_{c1,1} \cdot K_\gamma \cdot K_v \cdot K_{st} \cdot K_{ver}$$

k_c in N/mm² specific cutting force

h_m in mm average chip thickness

K_γ correction factor for the rake angle

K_v correction factor for the cutting speed

K_{ver} correction factor for the wear

z exponent (material constant)

$k_{c1,1}$ in N/mm² specific cutting force related to $h = b = l$

K_{st} correction factor for the chip compression

11.5.1.8 Average major cutting force per milling cutter edge

$$F_{cm} = b \cdot h_m \cdot k_c$$

F_{cm}	in N	average major cutting force per milling cutter edge
b	in mm	width of cut
h_m	in mm	average chip thickness
k_c	in N/mm ²	specific cutting force

11.5.1.9 Number of cutting edges in contact

$$z_E = \frac{z_w \cdot \varphi_s}{360^\circ}$$

z_E		number of cutting edges in contact
z_w		number of teeth on the milling cutter
φ_s	in °	angle of approach

11.5.1.10 Machine input power

$$P = \frac{F_{cm} \cdot v_c \cdot z_E}{60 \text{ s/min} \cdot 10^3 \text{ W/kW} \cdot \eta}$$

P	in kW	machine input power
F_{cm}	in N	average major cutting force per cutting edge
z_E		number of cutting edges in contact
η		machine efficiency
v_c	in m/min	cutting speed

11.5.2 Face milling

11.5.2.1 Angle of approach

The decision of whether to assign face milling to down- or up milling depends on the ratio

$$\frac{\text{Width of cut}}{\text{Cutter diameter}} = \frac{B}{D}$$

and the resulting feed motion angle φ_E at the end of the cutting procedure.

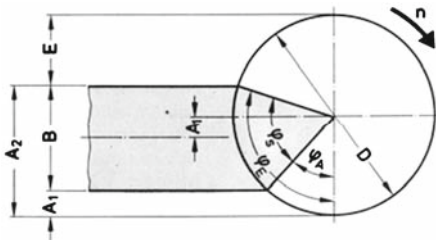


Figure 11.18a
Principle of face milling $\varphi_A > 0^\circ$

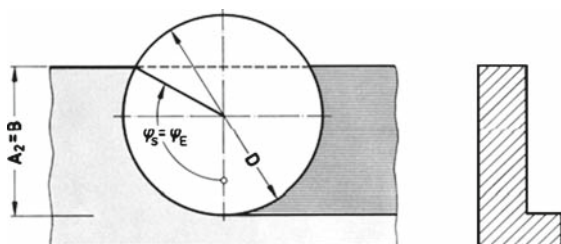


Figure 11.18b
Principle of face milling

$\varphi_E < 90^\circ \rightarrow$ up milling

$\varphi_E > 90^\circ - 180^\circ \rightarrow$ down milling

$$\cos \varphi_A = \frac{\frac{D}{2} - A_1}{\frac{D}{2}}$$

$\cos \varphi_A = 1 - \frac{2A_1}{D}$

$\cos \varphi_E = 1 - \frac{2A_2}{D}$

$\varphi_s = \varphi_E - \varphi_A$

For milling according to Figure 169b, it follows that:

$$A_1 = 0; \varphi_A = 0$$

$$\cos \varphi_E = \frac{B - \frac{D}{2}}{\frac{D}{2}}$$

$\cos \varphi_E = -\frac{2B}{D}$

φ_A in $^\circ$	feed motion angle at the beginning of the cut
φ_E in $^\circ$	feed motion angle at the end of cut
φ_s in $^\circ$	angle of approach (the greater φ , the more teeth are in contact)
A_1 in mm	distance from milling cutter diameter to the start of the workpiece, observed in the direction of rotation of the milling cutter
A_2 in mm	distance from milling cutter diameter to the end of the workpiece (the milling cutter leaves the workpiece - exit)
E in mm	distance from the end of workpiece to the milling cutter diameter
D in mm	milling cutter diameter
B in mm	workpiece width (corresponds to cutting contact a_c)

11.5.2.2 Selection of the milling cutter diameter

To obtain suitable contact conditions, the milling cutter diameter selected should be greater than the milling width B .

$D = 1,4 \cdot B$	For short-chipping materials e.g. cast iron
-------------------	---

$D = 1,6 \cdot B$	For long-chipping materials e.g. steel
-------------------	--

D in mm milling cutter diameter
 B in mm workpiece width

However, milling cutter diameter should not be greater than 150% of the milling spindle diameter

$D_{\max} = 1,5 \cdot d$

D_{\max} in mm max. milling cutter diameter
 d in mm milling spindle diameter

11.5.2.3 Lateral offset of the mill

To obtain optimal chip thickness values at the beginning and the end of the cut, the milling cutter's centre is shifted to the workpiece middle. As a rule of thumb (Figure 11.18), it follows that:

$\frac{A_1}{E} = \frac{1}{3}$

From this, we obtain:

$D = 1,4 \cdot B$	for cast iron
$A_1 = 0,1 \cdot B$	
$E = 0,3 \cdot B$	

$D = 1,6 \cdot B$	for steel
$A_1 = 0,15 \cdot B$	
$E = 0,45 \cdot B$	

11.5.2.4 Width of cut (Figure 11.19)

$b = \frac{a_p}{\sin \alpha}$	b in mm	width of cut
	a_p in mm	depth of cut
	α in °	plan angle ($\alpha = 45^\circ$ up to 90°)

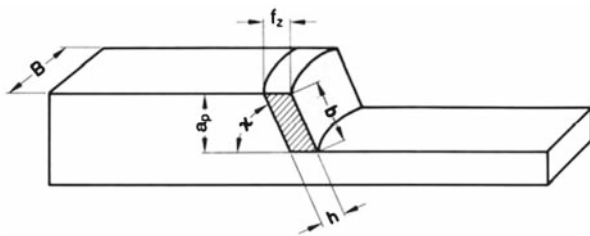


Figure 11.19
 Cutting parameters during face milling

11.5.2.5 Thickness of cut

To calculate the thickness of cut at a specific workpiece position, we use the equation below:

$$h = f_z \cdot \sin \varphi \cdot \sin \alpha$$

Since even during face milling, the thickness of cut changes over the length of contact toward the middle of the workpiece, average chip thickness h_m is used for calculation

$$h_m = \frac{114,6^\circ}{\varphi_s^\circ} \cdot f_z \cdot \frac{B}{D} \cdot \sin \alpha$$

h_m	in mm	average chip thickness
φ_s	in °	angle of approach
f_z	in mm	feed per cutting edge
B	in mm	workpiece width
D	in mm	milling cutter diameter
a_p	in mm	depth of cut
α	in °	plan angle

$$114,6^\circ \text{ is obtained from } \frac{360^\circ}{\pi}$$

11.5.2.6 Specific cutting force

$$K_c = \frac{(1 \text{ mm})^z}{h_m^z} \cdot k_{c1,1} \cdot K_\gamma \cdot K_v \cdot K_{\text{ver}} \cdot K_{\text{st}}$$

For the correction factors K_γ , K_v , K_{ver} and K_{st} , the same values as during peripheral milling are valid:

k_c	in N/mm ²	specific cutting force
h_m	in mm	average chip thickness
z		exponent (material constant)
K		correction factors
$k_{c1,1}$	in N/mm ²	specific cutting force related to $h = b = 1$

11.5.2.7 Average major cutting force per milling cutter edge

$$F_{\text{cm}} = b \cdot h_m \cdot k_c$$

F_{cm}	in N	average major cutting force per milling cutter edge
h	in mm	width of cut
h_m	in mm	average chip thickness
k_c	in N/mm ²	specific cutting force

11.5.2.8 Number of cutting edges in contact

$$z_E = \frac{\varphi_s \cdot z}{360^\circ}$$

z_E	number of cutting edges in contact
z	number of cutting edges of the mill
φ_s in °	angle of approach

11.5.2.9 Machine input power

$$P = \frac{F_{cm} \cdot v_c \cdot z_E}{60 \text{ s/min} \cdot 10^3 \text{ W/kW} \cdot \eta}$$

P in kW	machine input power
F_{cm} in N	average major cutting force per milling cutter edge
v_c in m/min	cutting speed
z_e	number of cutting edges in contact
η	machine efficiency

11.5.3 Simplified calculation of the volume removal rate for peripheral and face milling

For this method, the volume removal rate (cut per minute) Q is based on.

$$Q = \frac{a_p \cdot B \cdot v_f}{10^3}$$

$$v_f = f_z \cdot z_w \cdot n$$

$$n = \frac{v_c \cdot 10^3}{D \cdot \pi}$$

V in cm/min	removed volume
a_p in mm	depth of cut
B in mm	width of cut (or cutting contact a_c)
v_f in mm/min	feed rate (tangential v_t)
f_z in mm	feed per cutting edge
z_w	number of cutting edges
n in min ⁻¹	speed
v_c in m/min	cutting speed
D in mm	milling cutter diameter

The required machine input power is then obtained from the ratio of Q and a material constant K . This material constant is added the specific cutting force k_c and the commonly used conversion factors.

$$P = \frac{Q \cdot f}{K \cdot \eta_M}$$

P in kW	machine input power
Q in cm ³ /min	metal removal rate
K in cm ³ /min kW	material constant
η_M	machine efficiency
f	factor considering the technique (process factor)
$f = 1$	during peripheral milling
$f = 0,7$	during face milling with cutter heads

Table 11.1 Material constant K (excerpt from reference values by Neuhäuser, Mühlacker)

Material	K in $\text{cm}^3/\text{min kW}$
S 185–S 275 JR	16
E 295–E 335	11
E 360	9
alloyed steel 700–1000 N/mm^2	8
alloyed steel 1000–1400 N/mm^2	7
GJL 100–GJL 150	30
GJL 200–GJL 250	25
GJL 300–GJL 400	15
GE 200–GE 260	15
GS–60 W	12
CuZn 37–CuZn 30	42
Al alloy 13 % Si	50

11.6 Machining times during milling

For all milling techniques, the following relationship is valid:

$$t_h = \frac{L \cdot i}{f \cdot n} = \frac{L \cdot i}{v_f}$$

- t_h in min machining time
- L in mm total path
- i number of cuts
- f in mm feed per milling cutter rotation
- n in min^{-1} milling cutter speed
- v_f in mm/min feed rate

Comparing the different milling techniques, they only difference is in their total paths L to be inserted.

11.6.1 Peripheral milling

$$L = l_a + l + l_u$$

Paths valid for roughing:

$$l_a = 1,5 + \sqrt{D \cdot a_c - a_c^2}$$

$$l_u = 1,5 \text{ mm}$$

$$L = l + 3 + \sqrt{D \cdot a_c - a_c^2}$$

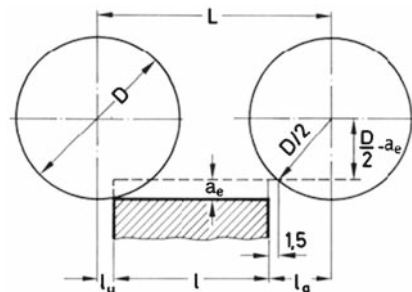


Figure 11.20 Total path L during peripheral milling

Paths valid for finishing:

$$L = l + 3 + 2 \cdot \sqrt{D \cdot a_c - a_c^2}$$

L	in mm	total path
l	in mm	workpiece length
D	in mm	milling cutter diameter
a_c	in mm	cutting contact

Since during finishing the cutting edges, which are still engaged, recut and create an uneven surface, we may equate

$$l_u = l_a$$

Thus, we obtain the equation above for the total path.

11.6.2 Face milling

11.6.2.1 Central face milling

For roughing, there is:

$$l_a = 1,5 + \frac{1}{2} \cdot \sqrt{D^2 - B^2}$$

$$l_u = 1,5 \text{ mm}$$

$$L = l + 3 + \frac{1}{2} \cdot \sqrt{D^2 - B^2}$$

For finishing, there is:

Due to recutting, $l_a = l_u$ is valid.

$$L = l + 3 + \sqrt{D^2 - B^2}$$

B	in mm	workpiece width
-----	-------	-----------------

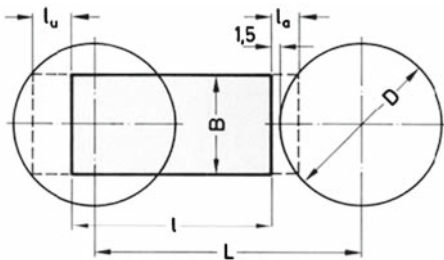


Figure 11.21
Total path L during central face milling

11.6.2.2 Eccentric face milling

For roughing, there is:

$$l_a = 1,5 + \frac{D}{2} - \sqrt{\left(\frac{D}{2}\right)^2 - B'^2}$$

$$l_u = 1,5 \text{ mm}$$

$$L = l + 3 + \frac{D}{2} - \sqrt{\left(\frac{D}{2}\right)^2 - B'^2}$$

$$B' = \frac{B}{2} + e = \frac{B}{2} + \left(\frac{D}{2} - A_1 - \frac{B}{2}\right)$$

$$B' = \frac{D}{2} - A_1$$

For finishing, there is:

$$L = l + 3 + D$$

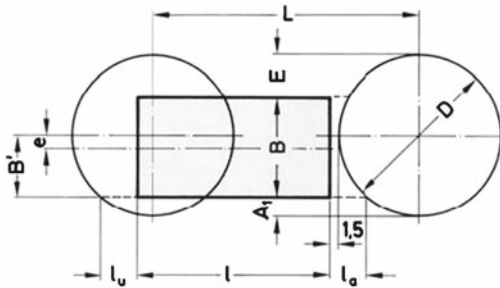


Figure 11.22
Total path L during eccentric face milling

11.6.3 Groove milling

$$L_1 = t + l_a$$

$$L_2 = l - D$$

$$i = \frac{t}{a_p}$$

$$l_a = 2 \text{ mm}$$

$$t_h = \frac{L_1 \cdot i}{f_1 \cdot n} + \frac{L_2 \cdot i}{f_2 \cdot n}$$

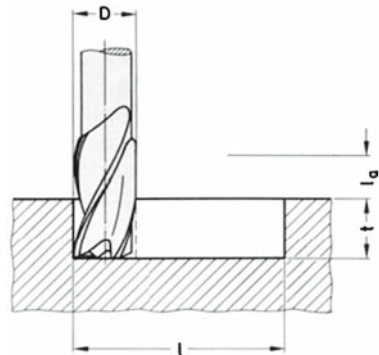


Figure 11.23
Paths during groove milling

- | | | |
|-------|----------------------|---|
| L_1 | in mm | vertical milling cutter path |
| L_2 | in mm | path in longitudinal direction |
| t | in mm | groove depth |
| l | in mm | groove length |
| i | | number of cuts |
| f_1 | in mm | feed per revolution in vertical direction |
| f_2 | in mm | feed per revolution in horizontal direction |
| n | in min^{-1} | speed of the end mill cutter |

t_h in min machining time

11.6.4 Short-thread milling

$$L = l_a + l = \frac{1}{6} \cdot d \cdot \pi + d \cdot \pi$$

$$L = \frac{7}{6} \cdot d \cdot \pi = 3,67 \cdot d$$

L in mm total path
 d in mm thread outer diameter
 $i = 1$

11.6.5 Long-thread milling

$$L = \frac{d \cdot \pi (l_a + l) \cdot z}{P}$$

L in mm total path
 l in mm length of the thread to be milled
 d in mm thread outer diameter
 z number of starts of the thread
 P in mm thread pitch
 l_a in mm addition for approach and overrun (l_a approx. 20 mm)

11.7 Milling cutters

11.7.1 Cutting edge forms and teeth number on the milling cutter

There is a fundamental difference between pointed tooth- and round cutting edges. The pointed tooth milling cutter edge (Figure 11.24) is generated by milling, whereas the rounded cutting edge form is made by relieving (the shape of a logarithmic helix).

The standard milling cutter is pointed tooth. It is used for almost all milling tasks.

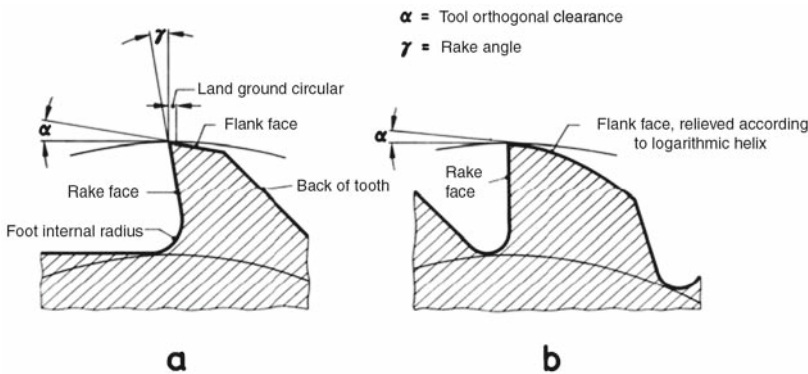


Figure 11.24

Cutting edge forms on milling cutters

a) Tooth form of the pointed tooth mill, b) Tooth form of the relieved mill

Only cutters of the former type are relieved milling cutters.

Pitch, tooth height and tooth fillet form the tooth space that collects the removed chips.

11.7.2 Flute direction, helix angle and cutting direction of the milling cutter

The angles and surfaces on the cutter blade or tooth are defined in the same way as on the turning tool.

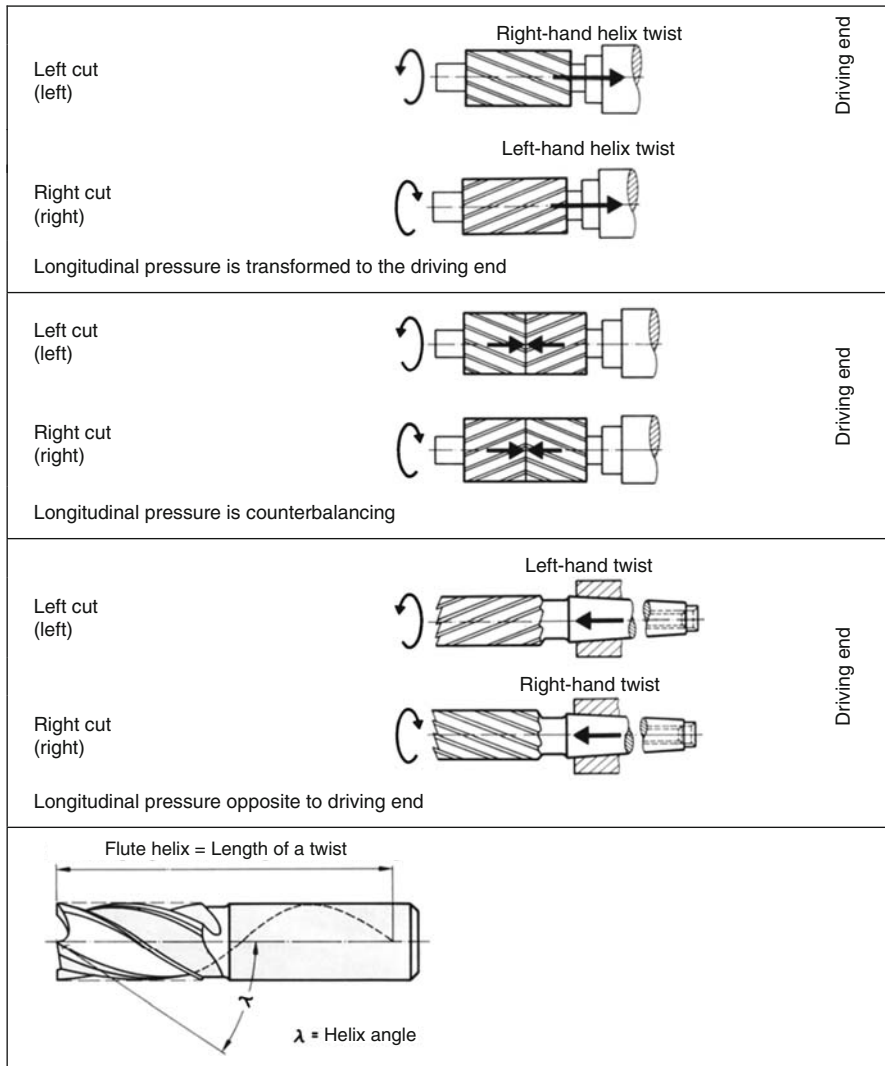


Figure 11.25

Helix angle, cutting- and flute directions on the plain milling cutter, shell end mill and end mill cutter (excerpt from DIN 857)

In addition to the angles already introduced in this book (see Figure 11.24) as tool orthogonal clearance α , wedge angle β and rake angle γ , the angle of inclination λ is very important here. On milling cutters, it is called the helix angle. As shown in Figure 11.25, cutting edges may have right- and left-hand helix twist. For the right-hand helix twist, the flutes are contorted to the right, which means that they are inclined from the left to the right bottom. Inclination is independent of the direction, from which it is seen.

On plain milling cutters, shell end mills and end mill cutters, we distinguish not only the flutes, but also the tool's cutting direction.

A milling cutter is regarded as right cut, if it rotates to the right, observed from the driving end.

11.7.3 Cutting edge geometry on milling cutters

The wedge of the cutter blade can be compared with the wedge of the turning tool. Figure 11.26 elucidates the geometric conditions on the plain milling cutter.

The geometric conditions on the cutter head are illustrated on Figure 11.27. Similarities between the turning- and the milling tool can be seen.

For the cutter heads, the plan angle ι ranges from 45° to 90° .

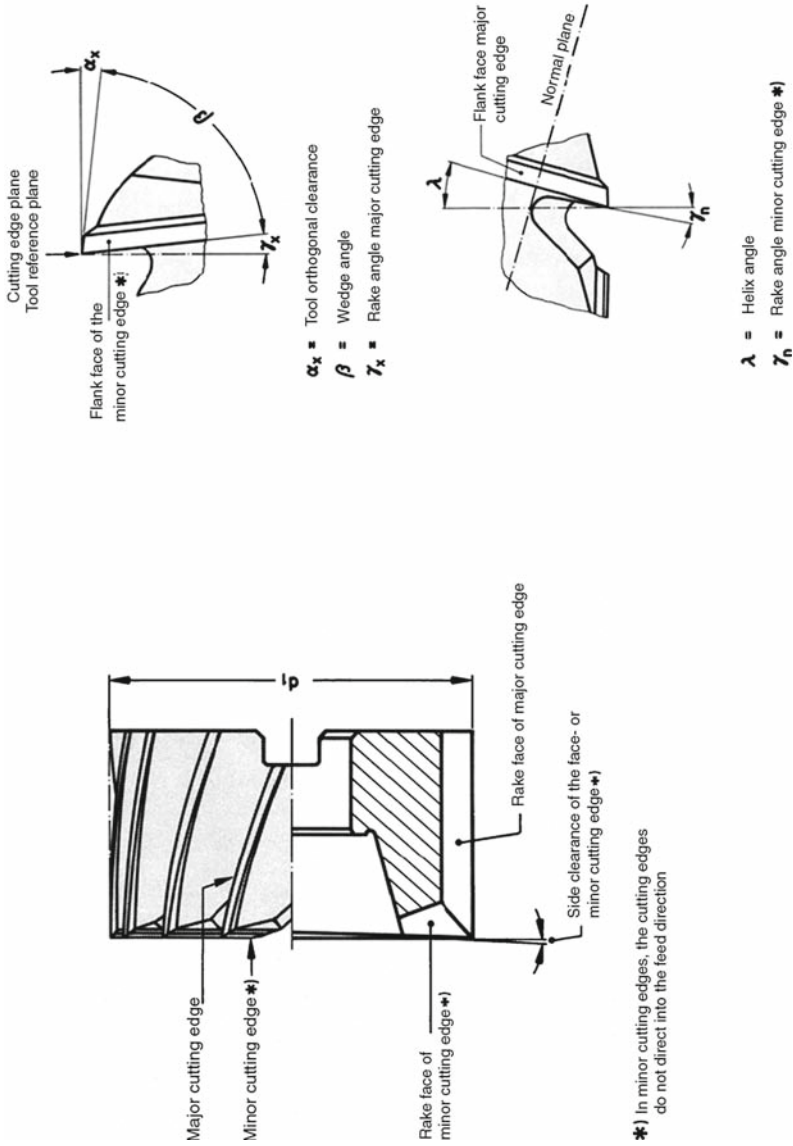


Figure 11.26
Surfaces and cutting edges on the plain milling cutter
(excerpt from DIN 6581)

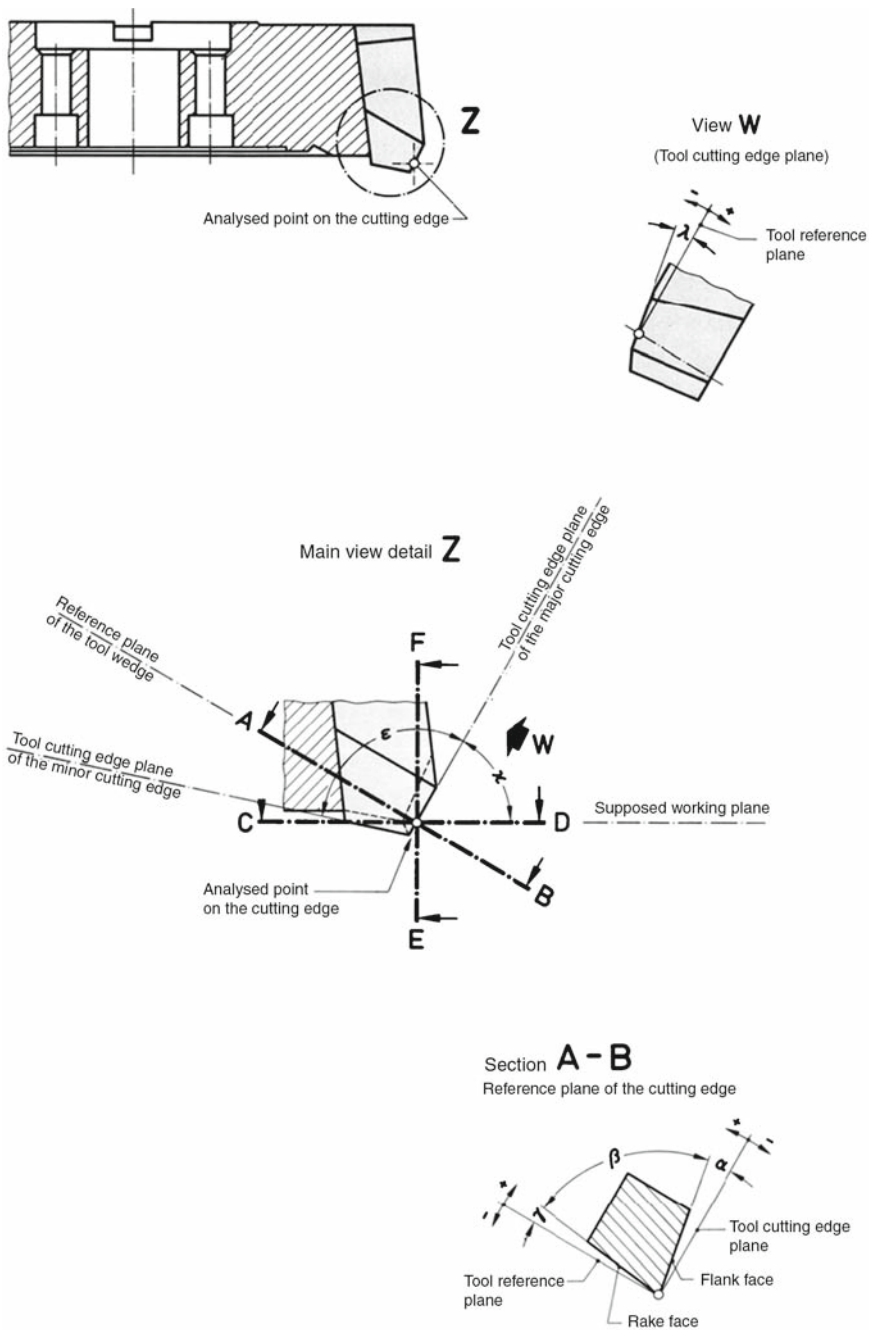


Figure 11.27
 Angles and cutting edges on cutter heads
 (excerpt from DIN 6581)

11.7.4 Plain milling cutters – design variants and ranges of application

Milling cutter types

In DIN 1836, milling cutters are subdivided into the tool types N, H and W.

Type N: is rough toothed and used for standard engineering steels, soft grey cast iron and for non-ferrous metals of medium hardness.

Type H: is fine toothed and used for hard and hard-tough materials.

Type W: is particularly rough toothed and used for soft and tough materials.

Table 11.2 Ranges of applications of the tool types (excerpt from DIN 1836)

Material	Strength respectively hardness Brinell in N/mm ²	Tool type		
Steel	up to 500	N		(W)
Steel	500–800	N		
Steel tough-hard	up to 1 000	N	(H)	
Steel tough-hard	up to 1 300		H	
Cast steel	380–520	N		
GJL 100–GJL 150	up to 1 800 HB	N		
GJL 200–GJL 300	> 1 800 HB	N	(H)	
CuZn 42–CuZn 37		N		(W)
Medium-hard Al alloy		N		(W)

11.7.4.1 Wide plain milling cutters (Figure 11.28)

Ranges of application

They are used for roughing and finishing of plain surfaces on horizontal milling machines. For heavy duty cuts, 2 plain milling cutters are coupled, meaning that they are linked through a kind of claw toothing (Figure 11.29).

The hands of the helices of both parts of the coupled milling cutters are opposite. As a result, the axial forces counterbalance each other.

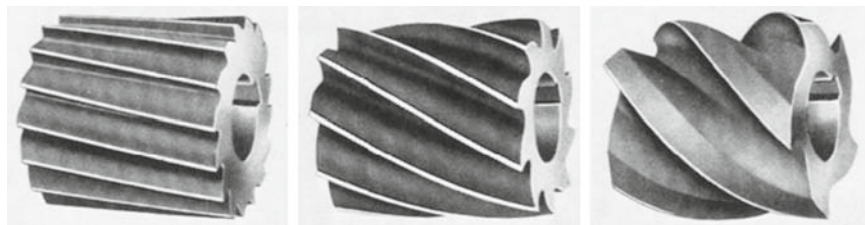


Figure 11.28
Plain milling cutter with key

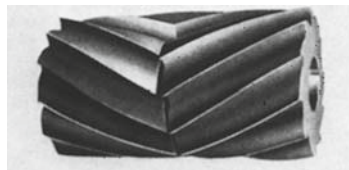


Figure 11.29
Coupled plain milling cutter

Standards:

DIN 884 plain milling cutter types N, H and W

DIN 1892 coupled plain milling cutters

Dimensions:

Milling cutter diameter in mm	Milling cutter widths in mm	Blade numbers		
		Type N	Type H	Type W
40–160	32–160	4–12	10–20	3–8

11.7.4.2 Shell end mills

Ranges of application:

The shell end mill (Figure 11.30) has not only peripheral cutting edges, but also cutting edges on one face. Consequently, it is used to manufacture plain and orthogonally offset surfaces.

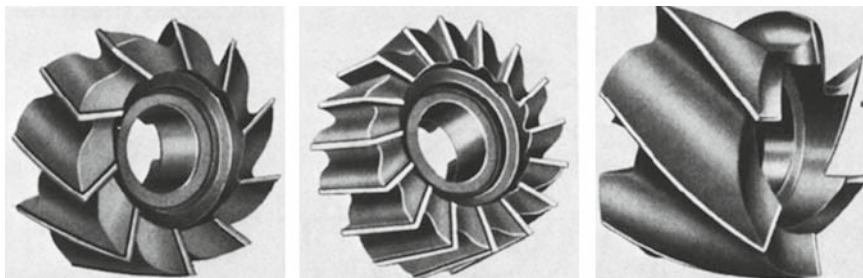


Figure 11.30
Shell end mill with cutter

Standards:

DIN 1880

DIN 8056 with cemented carbide cutting edges

Dimensions:

Milling cutter diameter in mm	Milling cutter widths in mm	Blade numbers		
		Type N	Type H	Type W
30–150	30–63	6–14	10–20	3–8

11.7.4.3 Side and face milling cutters

Ranges of application:

The side and face milling cutter is equipped with circumferential face cutting edges on both sides (Figure 11.31). This type is used to generate continuous keyways up to 32 mm wide. Side and face milling cutters are available in straight- and staggered-tooth design. The staggered-tooth mill in which the cutting edges penetrate the material step by step works more quietly. For this reason, staggered-tooth milling cutters (form A) are preferentially used for heavy duty cuts. Straight-toothed milling cutters (form B) are used to manufacture flat grooves.

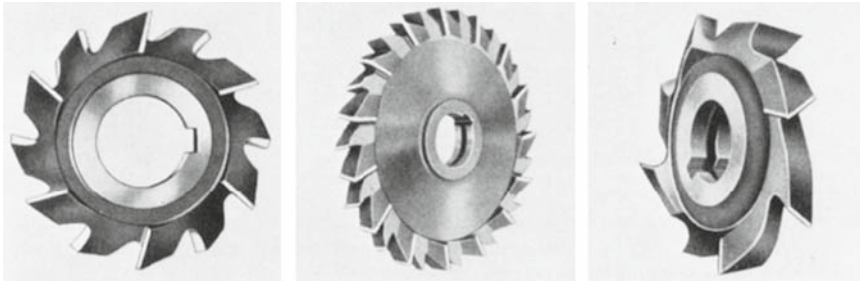


Figure 11.31
Side and face milling cutter, staggered-tooth, form A

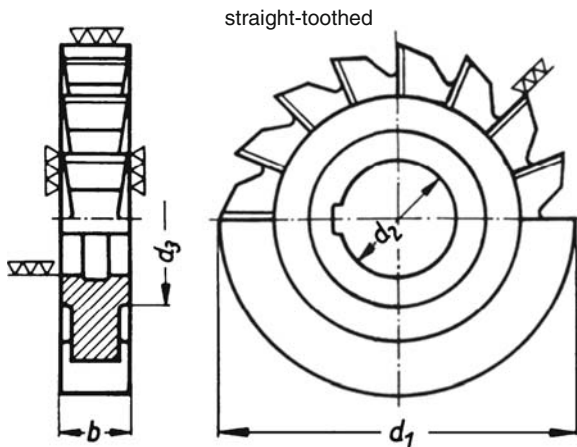


Figure 11.32
Side and face milling cutter, straight-toothed, form B

Standards:

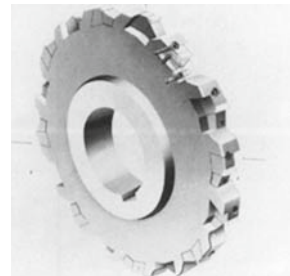
- DIN 885 form A staggered-tooth, form B straight-toothed
- DIN 1831 with inserted blades, staggered-tooth
- DIN 8047 with cemented carbide edges
- DIN 8048 with exchangeable cemented carbide blades

Dimensions:

Milling cutter diameter in mm	Milling cutter width in mm	Blade numbers (form A)		
		Type N	Type H	Type W
50–200	5–32	12–20	16–36	6–12

11.7.4.4 Slot drills*Ranges of application:*

Slot drills or grooving cutters are coupled staggered-tooth side and face milling cutters whose width can be readjusted by spacers (Figure 11.33). The dimension for setting in width is from about $\frac{1}{10}$ up to $\frac{1}{8}$ of the mill's nominal width. The slot drill cuts, like the side and face milling cutter, on 3 sides.

**Figure 11.33**

ISO side and face milling cutter with inserted cemented carbide tips

Standards:

DIN 1891 B coupled and readjustable, staggered-teeth

Dimensions:

Milling cutter diameter in mm	Milling cutter width in mm	Blade numbers		
		Type N	Type H	—
63–200	12–32	14–20	18–36	

11.7.4.5 Angle milling cutters and single- angle cutters*Ranges of application:*

Angle milling cutters according to DIN 1823 are used to generate blockouts and recesses, such as flutes on tools (Figure 11.34).

The single-angle cutter DIN 842, which has additional cutting edges on the face, is used to produce cavities for guideways (e.g. dovetail guides) (Figure 11.35).

The milling cutter angle (plan angle τ) is 50° for single-angle cutters. For special designs, this angle ranges from 55° to 80° .



Figure 11.34
Angle milling cutter

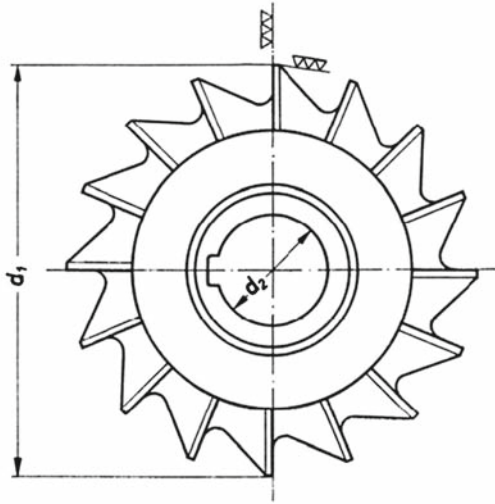
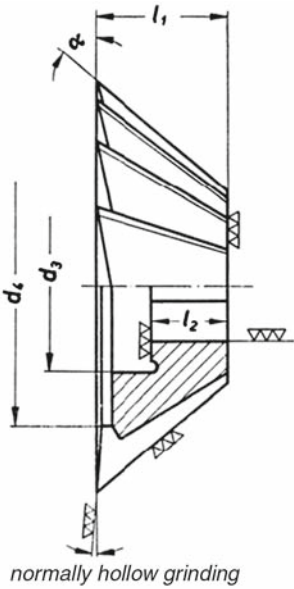


Figure 11.35
Single-angle cutter

Standards:

DIN 1823 Angle milling cutter

DIN 842 Single-angle cutter

Dimensions:

Milling cutter diameter in mm	Cutter angle	Blade number		
		DIN 1823A	DIN 1823B	DIN 842
50–100	55°–80°	16	16–20	14–24

11.7.4.6 Vee-form milling cutters and circular milling cutters of the former type

Ranges of application:

Vee-form or equal angle cutters (Figure 11.36) generate prismatic shapes with 45°, 60° and 90° angles. Single corner rounding cutters and radius cutters (Figure 11.37) are used to generate circular contours.

Radius cutters are subdivided according to the direction of concavity into convex (arched to the outside) and concave (arched to the inside) radius- and single corner rounding cutters of the former type. These milling cutters allow for making radii from 1 up to 20 mm to be made.

Standards:

- DIN 847 vee-form or equal angle cutters
- DIN 855 radius cutters of the former types, arched to the inside
- DIN 856 radius cutters of the former types, arched to the outside

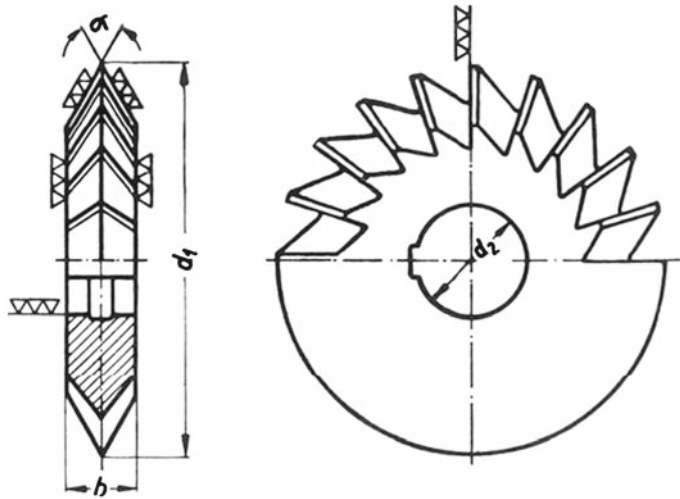
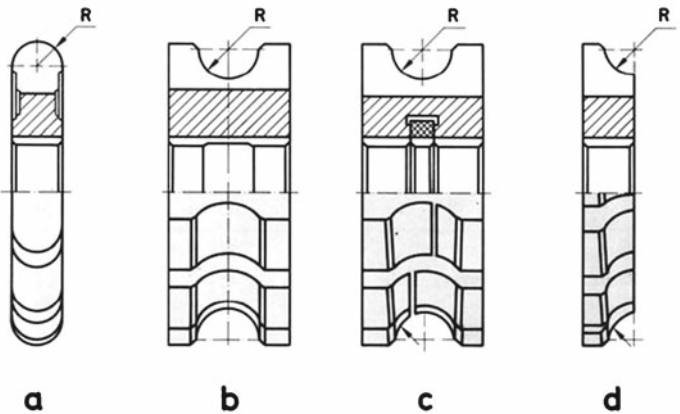


Figure 11.36
Vee-form milling cutter

R = Form radius

Figure 11.37
Circular milling cutter of the former type

- a) radius cutter, arched to the outside (convex)
- b) radius cutter, arched to the inside (concave)
- c) coupled and readjustable radius cutter
- d) single corner rounding cutter



11.7.4.7 End mill cutters

End mill cutters are milling cutters with a shank.

As in twist drills, we subdivide them into milling cutters with cylindrical shank and milling cutters with taper shank (Morse taper 1–5, depending on each milling cutter diameter).

Ranges of application:

According to their range of application, we classify them into:

End mill cutter for peripheral- and face milling

End mill cutters for peripheral- and face milling (Figure 11.38) are milling cutters with peripheral- and face cutting edges with helical flutes. In contrast to the slotting end mill, end mill cutters have more than 2 cutting edges. As a function of the pitch, we subdivide them into the milling cutter types N, H and W. Figure 11.38a shows an end mill cutter under work.

For roughing, milling cutters with additional flutes (Figure 11.38d and e) that are implemented in a thread-like manner are used. End mill cutters of this type are available up to 63 mm diameter.

Slotting end mill

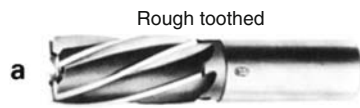
Slotting end mills (Figure 11.39) are special-type mills to produce grooves. Following DIN 326 and DIN 327, they have only 2 face- and 2 peripheral cutting edges.

However, customised types with 3 cutting edges are also available.

In DIN 1836, the milling cutters are classified into three tool types - according to their range of application.

Tool type N:

For common mild steels, soft grey cast iron, medium-hard non-ferrous metals



Tool type H:

For particularly soft and tough-hard materials



Tool type W:

For particularly soft and tough materials



Tool type NR:

For roughing



Design of the FETTE-rough toothing (knurling thread)

With rough toothing- knurling thread



Tool type NF:

For roughing and finishing operations



Design of the flattened FETTE-finishing thread

With flattened rough finishing thread



The rough toothing-knurling thread and the rough-finishing thread are also called “chip dividing- or breaker threads“, since they break the chip during milling.

Figure 11.38

End mill cutter a) Type N rough toothed, b) Type H fine toothed, c) Type W extra rough toothed, d) milling cutter with rough toothing (knurling thread), e) flattened rough- toothing with finishing thread

Figure 11.38a
End mill cutter tipped with cemented carbide inserts

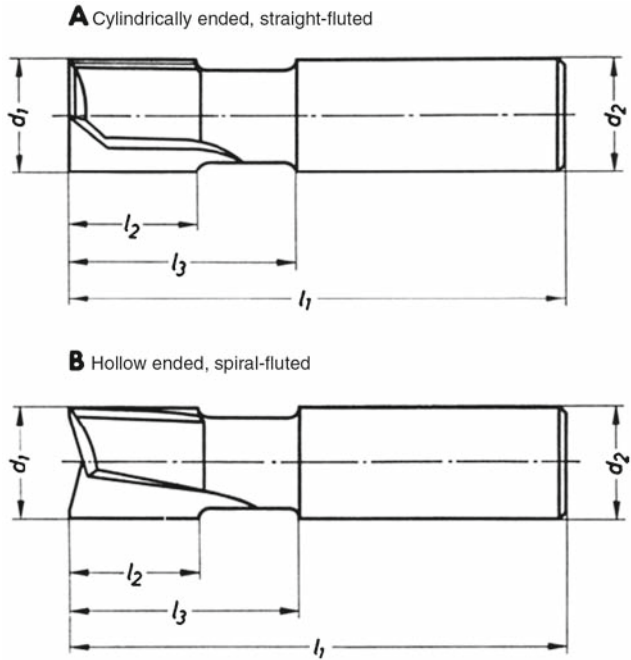
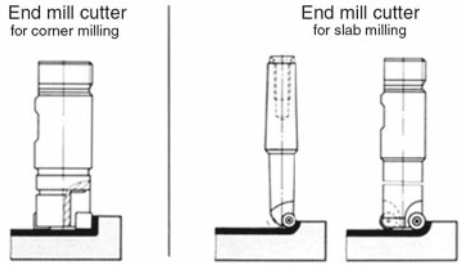


Figure 11.39
Slotting end mill

End mill cutter for T grooves

The end mill cutter to produce T grooves according to DIN 650 (Figure 11.40) is a special milling cutter tailored to this purpose.

The tool is standardised under DIN 851.

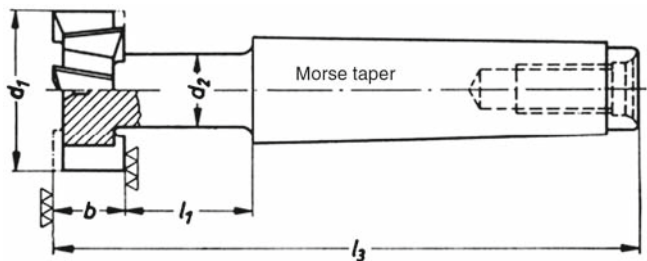


Figure 11.40
End mill cutter to generate T grooves

Standards:

- DIN 844 End mill cutter with cylindrical shank
- DIN 845 End mill cutter with Morse taper
- DIN 326 and 327 Slotting end mill
- DIN 851 Slotting cutter (T slots).

11.7.5 Cutter heads

Ranges of application:

Inserted-tooth cutters or cutter heads are face milling cutters (Figure 11.41) to mill plane surfaces.

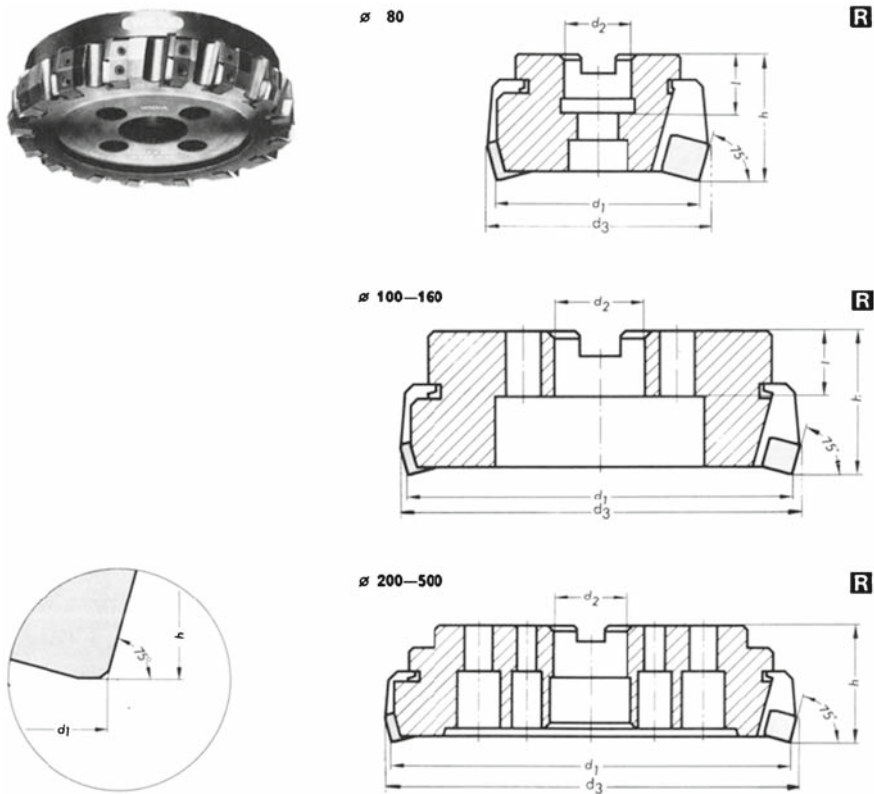


Figure 11.41
Cutter head for slab milling with negative indexable inserts
(photo by *Krupp Widia-Fabrik, Essen*)

Corner milling cutters (Figure 11.42) are cutter heads with a 90° plan angle to be used for the generation of orthogonally offset surfaces.

The metal removal rate of a cutter head is clearly better than that of a plain milling cutter.

For this reason, planar surfaces are predominantly generated with cutter heads instead of plain milling cutters. In addition to the high metal removal rate, cutter heads are capable of generating substantially better surface qualities than those achieved by peripheral milling.

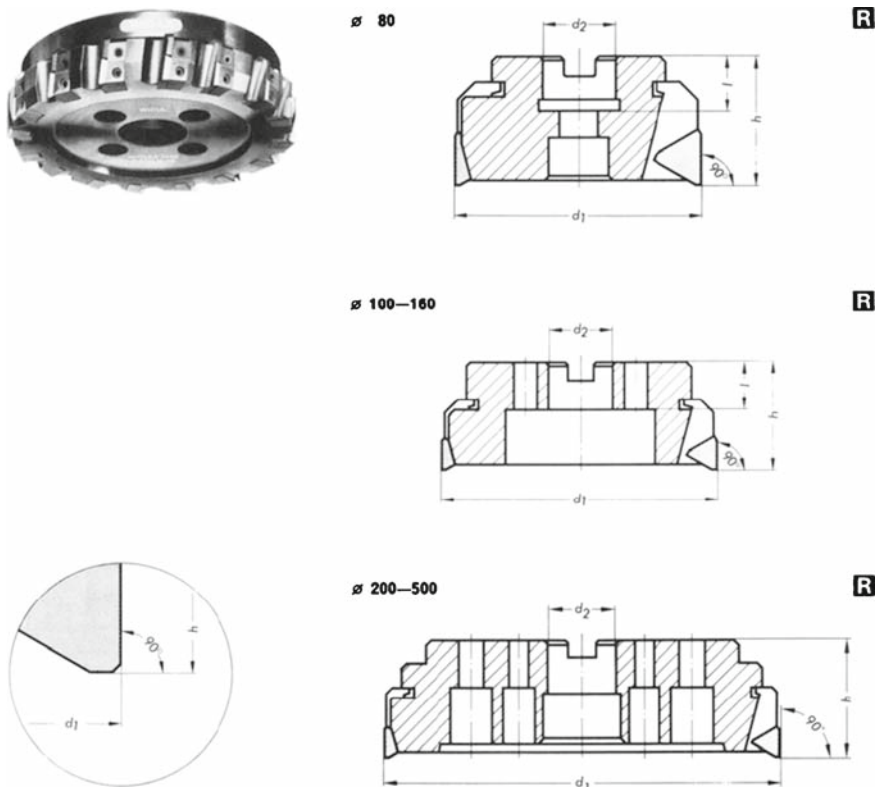
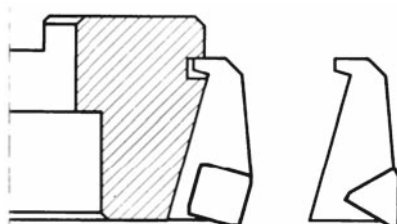


Figure 11.42
Cutter head, designed as corner milling cutter
(photo by Krupp Widia-Fabrik, Essen)

Cutter heads are mostly equipped with easy-to-exchange cemented carbide indexable inserts.

Triangular and square indexable insert forms are mostly in use (Figure 11.43).

Figure 11.43
Indexable inserts for cutter heads - basic forms



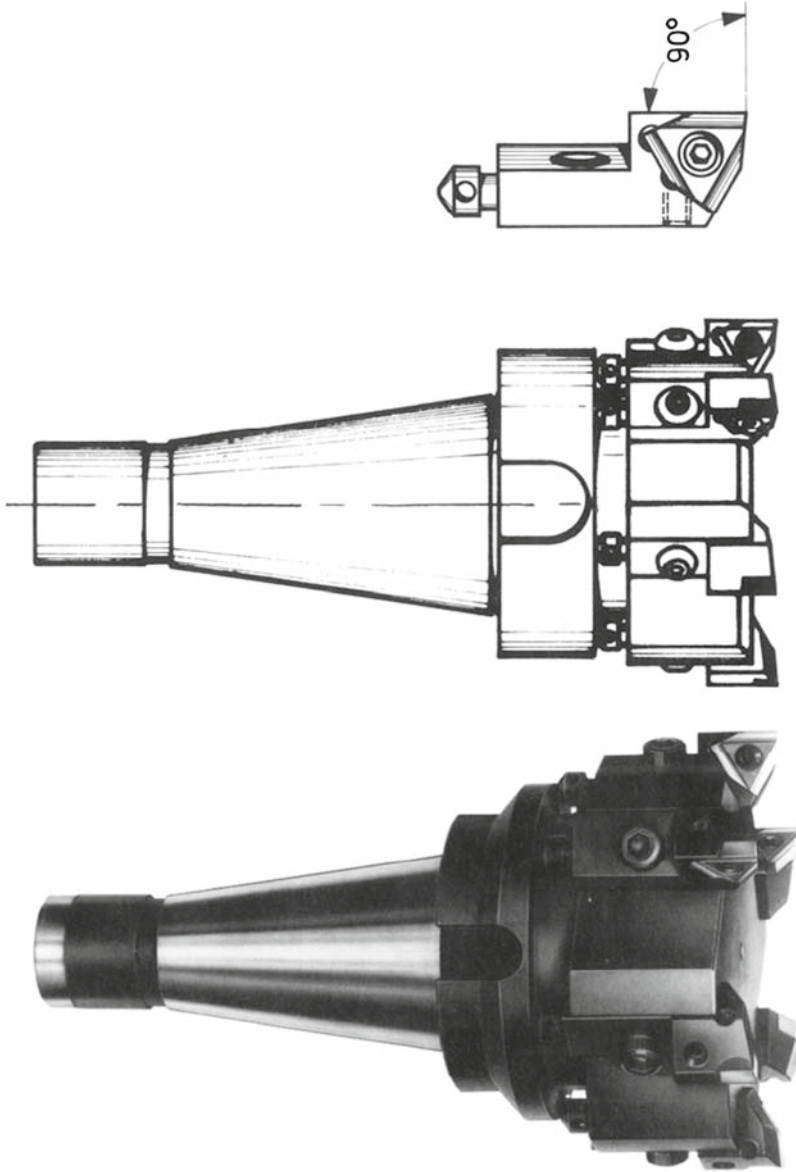


Figure 11.44
Cutter head with exchangeable indexable milling inserts
(photo by Komet, Besigheim)

Special forms with whetted chamfers and positive rake angles are used for finishing.

The indexable inserts are fixed in the cutter head with clamping systems similar to those mentioned under Chapter 8.8.1.2.

Figures 11.44 and 196 show some other design variants of cutter heads.

Figure 11.45 illustrates a cutter head with 75° plan angle in which it is possible to replace the carriers of the indexable inserts with just a few manipulations. Thus, it becomes possible to reset this cutter head also for other plan angles.

Figure 11.45 shows a face milling cutter (cutter head) to be reground, with blades allocated on the face.



Figure 11.45

Face milling cutter (cutter head) with blades to be reground

Table 11.3 Cutter head dimensions in mm and number of cutting edges according to DIN 2079 (excerpt from tables by Krupp Widia-Fabrik, Essen)

Nominal diameter d_1	Outer diameter d_3	Hole diameter d_2	Height h	Number of cutting edges z
80	86	27	50	5
100	106	32	50	7
125	131	40	63	8
160	166	40	63	10
200	206	60	63	12
250	256	60	63	16
315	321	60	80	18
400	406	60	80	22
500	506	60	80	26

11.7.6 Tool holders for plain milling cutters

The task of the tool holders is to tightly and reliably affix the milling cutters to the milling spindle of the machine.

The fastening element for the milling cutters is adopted in the inner taper of the milling spindle and centred. Torque occurring during milling is transmitted through frictional resistance in the taper. Additionally, torque is transmitted positively by drive buttons. The holding tools mostly in use are explained below.

11.7.6.1 Milling-cutter arbours

The milling-cutter arbour or cutter arbour (Figure 11.46) is a longitudinally grooved shaft in which one shaft end is designed as a steep taper while the other end is shaped like a thread. The milling cutter to be held is clamped with the locknut and placed on the thread upon bushings against the shoulder of the milling-cutter arbour. The milling-cutter arbour itself is mounted in the steep taper of the milling spindle and pulled into the taper with a drawbar. Since steep tapers are not self-retaining, the milling-cutter arbours can be easily removed from the steep taper.

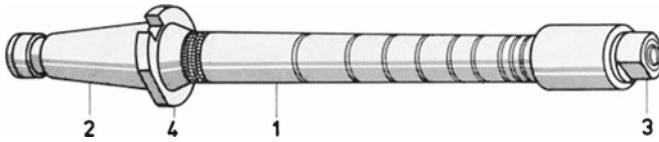


Figure 11.46

Milling-cutter arbour

1 grooved shaft,

2 steep taper,

3 thread with locknut,

4 shoulder

Due to their length ($L = 316$ up to 1230 mm) they have to be additionally supported (rested) in the milling machine in order to limit deflection. A steady rest (Figure 11.47) is used for support. The steady rest is positioned flexibly in the steady or overarm of the milling machine. An arbour bearing sleeve is used as step bearing, which is set on the cutter arbour. This sleeve brings the milling cutter into the correct position, as the cutter arbour rings do.

Milling-cutter arbours and accessories are standardised as given below:

DIN 6355	milling-cutter arbours with steep taper shank
DIN 2086	milling-cutter arbours with Morse taper shank
DIN 2083	arbour bearing sleeves
DIN 2084 and 2085	clamping rings

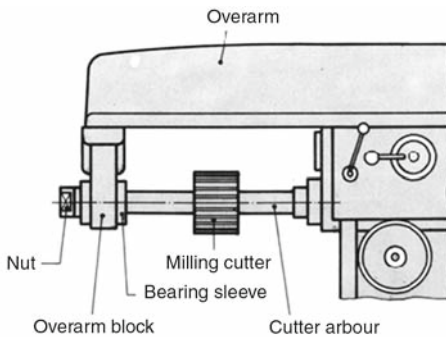


Figure 11.47

Alignment of the milling-cutter arbour, supported in the steady rest of the milling machine

The milling-cutter arbour is used to mount plain milling cutters, as well as side and face milling cutters. Figure 11.48 shows a milling-cutter arbour with side and face milling cutters in practical use on a milling machine by Fritz Werner, Berlin.

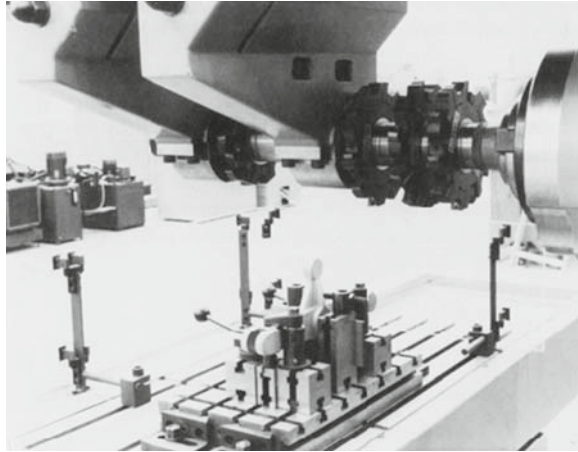


Figure 11.48
Milling-cutter arbour with side and face milling cutters and step bearings in practical use (photo by DIAG, Fritz Werner plant, Berlin)

11.7.6.2 Shell end mill arbours

Shell end mill arbours are limited according to length and work without any support by an additional bearing.

They are preferentially used for shell end mills.

We distinguish between shell end mill arbours according to DIN 6360 for milling cutters with keyway (Figure 11.49), and milling cutters with cross-slot according to DIN 2086 parts 2/3 (Figure 11.50).

The shell end mill arbours with steep taper are defined under DIN 6360, whereas the milling cutter pull studs are described under DIN 6367.

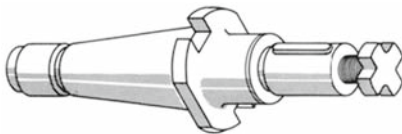


Figure 11.49
Shell end mill arbour with keyway according to DIN 6360

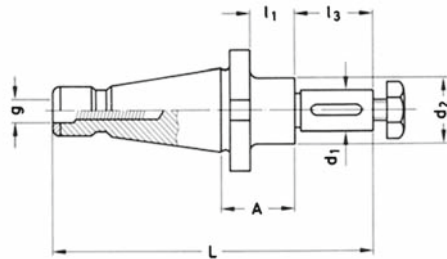
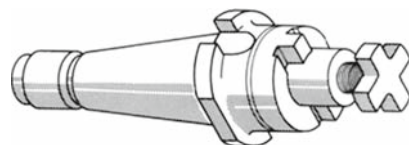


Figure 11.50
Shell end mill arbour with cross-slot according to DIN 6361



11.7.6.3 Milling adaptors

Milling adaptors (DIN 6364) are used to mount end mill cutters with Morse taper and tapped shank (Figure 11.51). For this reason, a hexagon socket screw is inside the milling collet, and the milling cutter shank is pulled with this screw into the Morse taper (screw-in type).

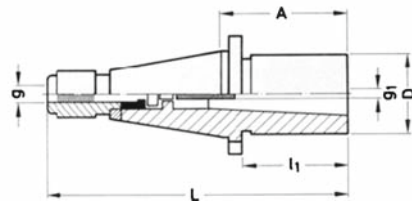
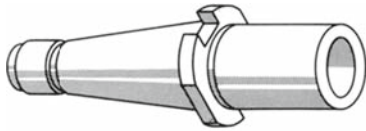


Figure 11.51
Milling adaptor for tools with Morse taper and tapped shank

11.7.6.4 Milling collet

The milling collet is used to clamp milling cutters with cylinder shank. The collet with clamping screws according to DIN 1835 is used for milling cutters with lateral lock-in area (Fig. 11.52a)

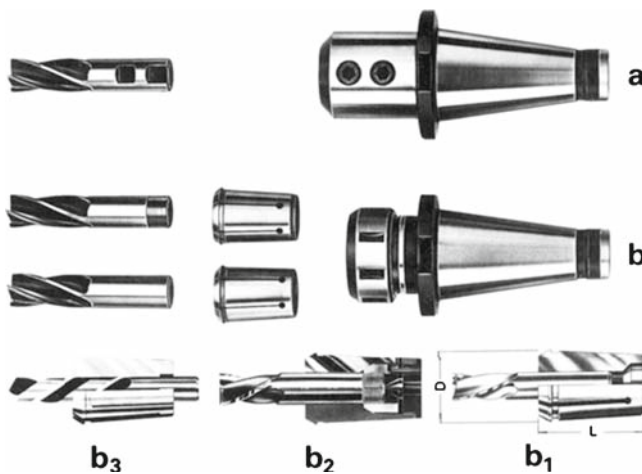


Figure 11.52
Milling collet for milling cutters with cylindrical shank
a) for milling cutters with lateral lock-in area
b) clamping chuck with collet
b₁ standard collet
b₂ collet for milling cutters with external thread
b₃ short collet able to chuck also twist drills on the margin.
(photo by Kelch and Co, Schorndorf)

The chucks with collets are most frequently in use. High clamping forces are achieved thanks to the slim tapers of the collets (Figure 11.52b). In the chucks newly developed by Kelch, it is additionally possible to fix the end milling cutters in their axial position inside the collets.

In the collet for tools with a smooth cylindrical shank (Figure 11.52b1), the tool position is adjusted in axial direction with a locating screw.

The collet in Figure 11.52b2 holds the milling cutter in its axial location using an external thread on the milling cutter.

11.7.7 Mounting and fastening of cutter heads

Cutter heads are either incorporated directly into the machine- or boring mill spindle, or indirectly via an adaptor sleeve.

For direct holding in the milling machine spindle (Figure 11.53), we distinguish between 2 design types according to DIN 2079. In design variant A, the cutter head is centred at the outer diameter of the milling spindle and fixed with hexagon socket screws. The torque is transmitted via a cotter. In design type B, the cutter head is centered internally via an arbour made with an internal tapped shank.

For smaller cutter heads, it is impossible to center the cutter head in the spindle directly internally or externally; consequently, an adaptor sleeve is used.

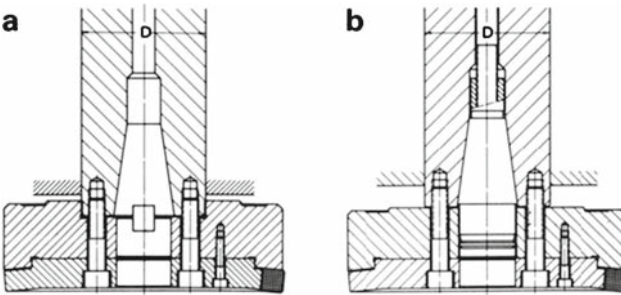


Figure 11.53

Direct fixing of cutter heads in the milling machine spindle

- a) with outside centering, DIN 2079 A,
- b) with inside centering DIN 2079 B

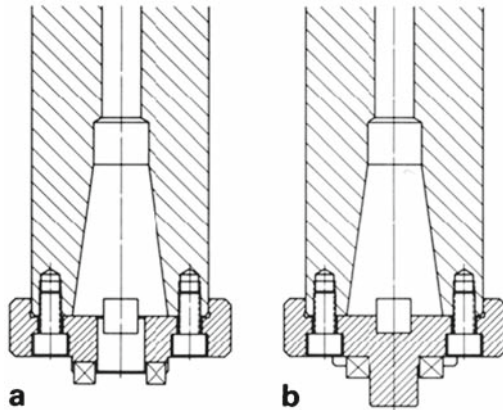


Figure 11.54

Adaptor sleeves to hold the cutter heads

- a) spindle- and cutter head side centered outside
- b) spindle side centred outside, cutter head side centered inside

Adaptor sleeves (Figure 11.54) like these have an outside centering on the spindle side.

On the cutter head side, the adaptor sleeve according to the design type A (Figure 11.54a) has an outside centering, whereas in design variant B (Figure 11.54b), it is centered inside.

11.7.8 Cutting materials

11.7.8.1 Tools made of high speed steel

High speed steel is the preferential material for plain milling cutters, shell end mills and end mill cutters. High speed steel is subdivided into three groups:

a) *Common high speed steel*

The common high speed steels are steels of maximum toughness, but limited high-temperature strength.

Table 11.4 elucidates some high speed steels commonly used for milling cutters.

Table 11.4 High speed steels for milling cutters

Material-No.	EN 96
1.3318	HS 12-1-2
1.3343	HS 6-5-2
1.3346	HS 2-9-1
1.3355	HS 18-0-1
1.3357	HS 18-0-2

b) *High speed steels alloyed with cobalt*

High speed steels alloyed with cobalt (also called HSS-E) are very tough steels with excellent high-temperature strength. They are distinguished from the steels of group a) through further cobalt additions from 3 to 5 %.

Table 11.5 HSS-E qualities

Material-No.	EN 96
1.3211	HS 12-1-5-5
1.3243	HS 6-6-2-5

c) *HSS-ES steels (cobalt-based super alloys)*

The high speed steels (ES steels) are steels whose high-temperature strength and wear strength have been enhanced.

These are highly alloyed steels, with 1,2 to 1,4 % C content, 3,5 to 4 % vanadium and cobalt contents from 5 to 11 %. These steels are more brittle than the common high speed steels and the high speed steels alloyed with cobalt. For this reason, milling cutters made of high speed steel ES should have large cross sections; otherwise the teeth would break off.

Consequently, the HSS- ES qualities are only used for mills whose diameters are greater than 20 mm.

Table 11.6 HSS- ES qualities

Material-No.	EN 96
1.3202	HS 12-1-4-5
1.3207	HS 10-4-3-10

High speed tools are frequently coated with hard materials (TiC, TiN) to improve tool life travel.

11.7.8.2 Cemented carbide

For roughing operations, milling cutters with inserted cemented carbide cutting edges (indexable inserts) are predominantly used.

End mill cutters are generally totally made of cemented carbide, with/ without hard material coating (TiC, TiN) , characterised by increased tool life travel.

11.8 Failures during milling

Table 11.7

Consequence for the tool	Reason for the fault	Remedy
Tool life too short (tools made of high speed steels)	Cutting speed too high	Reduce v
	Rake angle too small small tool orthogonal clearance	Check angles
Cutting edges on the mill break off	Feed s_z per milling cutter edge too large	Diminish feed s_z
	Chip space between the cutting edges too small	Use tool with other pitch or other tool type
	Tool climbs during down milling	Remove spindle backlash in the milling machine table
Milling cutters (plain milling cutters) are not parallel to the milling spindle axis	Faces of the cutter arbour rings and the locknut are not orthogonal to axis	Exchange locknut and cutter arbour rings
Milling cutter jams on the cutting edge back (crest) (plain milling cutter, end mill cutter)	Tool orthogonal clearance too small	Increase tool orthogonal clearance

Table 11.7 (continued)

Consequence for the tool	Reason for the fault	Remedy
Insufficient tool life of cutter heads (cemented carbide tips)	Incorrect angles on the tool	Grind indexable insert so that only the chamfers have a negative rake angle, whereas the major cutting edge has a positive rake angle
	Cutter head runs out	Check centre for mounting
Indexable inserts made of cemented carbide break off on the cutter head	Chosen cemented carbide sort too brittle	Use tougher cemented carbide
	Indexable inserts not correctly clamped or bearing surfaces not plane	Check chucking system on the cutter head crest
Insufficient surface quality	Cutting speed too low	Increase v
	Feed per cutting edge too high	Diminish feed
	Milling cutter chatters (due to vibrations)	Reinforce milling-cutter arbour
	Cutting forces too high	Decrease sectional area of chip or increase rake angle
	Insufficient workpiece clamping	Check clamping
Surface has equidistant indentations	Milling cutter (plain milling cutter, disk milling cutter or end mill) runs out	Check milling-cutter arbour and clamping element or milling cutter shank

11.9 Reference tables

Table 11.8 Diameter and tooth numbers for plain milling cutters made of high speed steel

Type	Milling cutter diameter in mm ↓ Milling cutter →	10	20	30	40	50	63	80	100	125	160	200
		N	Plain milling cutter DIN 884				4	4	5	7	8	10
Shell end mill DIN 841					6	6	7	8	10	12	14	
Side and face milling cutter DIN 885A						12	14	14	14	16	18	20
End mill cutter DIN 844	4		4	6	6	8	10					
Slotting end mill DIN 326D	2		2	2	2							

Table 11.8 (continue)

Type	Milling cutter diameter in mm ↓ Milling cutter →	10	20	30	40	50	63	80	100	125	160	200
		H	Plain milling cutter				10	10	10	12	14	16
Shell end mill					12	12	12	14	16	18	20	
Side and face milling cutter						16	18	20	24	28	28	36
End mill cutter	6		8	10	12	12	14					
Slotting end mill	2		2	2	2							
W	Plain milling cutter				3	4	4	4	5	6	8	
	Shell end mill				3	4	5	6	6	6	8	
	Side and face milling cutter					6	6	6	8	8	10	12
	End mill cutter	3	3	4	4							
	Slotting end mill	2	2	2	2							

Table 11.9 Angles (in °) on milling cutters made of high speed steel

Material	Plain milling cutter and shell end mill			Side and face milling cutter			End mill cutter		
	α	γ	λ	α	γ	λ	α	γ	λ
Steel up to 850 N/mm ²	6	12	40	6	12	15	7	10	20
Cast steel	5	12	40	5	10	20	6	10	30
Grey cast iron	6	12	40	6	12	15	7	12	30
Brass	6	15	45	6	15	20	6	12	35
Al alloy	8	25	50	8	25	30	10	25	40

Table 11.10 Feeds per cutting edge f_z in mm and permissible cutting speeds for milling with tools made of high-speed steel and cemented carbide for cutting depths $a_c = 8$ mm (roughing) and $a_c = 1$ mm (finishing) or for milling cutter widths b in mm (side and face milling cutter), or milling cutter diameter in mm (end mill cutter)

Material	Strength respectively Brinell hardness in N/mm ²	Plain milling cutter			Shell end mill			Side and face milling cutter		End mill cutter			Tool material
		f_z	a_c		f_z	a_c		f_z	b	f_z	\varnothing		
			8	1		8	1				up to 20	up to 20	
S 185-S 275 JR	up to 500	0,22	24	33	0,22	20	30	0,12	16	0,1	28	24	SS
C 15-C 22		0,18	120	200		120	200		180		200	180	
E 295-E 335	500-800	0,18	20	33	0,18	18	30	0,12	14	0,08	24	20	SS
C 35-C 45		0,12	80	200		70	180		120		150	160	
E 360	750-900	0,12	15	28	0,12	14	25	0,09	12	0,06	22	18	SS
C 60		0,12	70	150		65	140		100		140	120	
16 MnCr 5	850-1000	0,12	10	25	0,12	9	18	0,08	16	0,08	20	16	SS
30 Mn 5		0,09	50	100		45	90		100		70	80	
42 CrMo 4	1000-1400	0,09	8	13	0,09	7	12	0,07	10	0,06	24	20	SS
50 CrMo 4		0,18	20	60		20	60		80		60	50	
GE 240-GE 260	450-520	0,18	12	16	0,12	10	14	0,09	12	0,08	20	18	SS
GJL 100-GJL 200		0,22	40	85		35	80		100		90	70	
GJL 250-GJL 300	1400-1800 HB	0,22	15	25	0,22	13	22	0,12	14	0,08	20	18	SS
GJL 250-GJL 300		0,22	60	100		55	90		120		90	70	
CuZn 37-CuZn 42 (Ms 63)	1800-2200 HB	0,22	10	18	0,18	9	16	0,09	12	0,07	18	14	SS
Al alloy		0,22	40	80		35	75		100		80	60	
9-13 % Si	800-1200 HB	0,22	35	75	0,18	32	70	0,08	40	0,08	60	50	SS
Al alloy		0,12	80	200		75	180		150		110	100	
9-13 % Si	600-1000 HB	0,12	80	200	0,12	70	180	0,09	180	0,06	240	200	SS
9-13 % Si		0,12	100	300		90	280		250		300	250	

SS stands for high speed steel, while HM stands for cemented carbide

The given v_c values are valid for a tool life travel of 15 m.

The feeds per tooth f_z in mm are valid for roughing. For finishing, these values have to be diminished by between 40 and 50 %.

For disk- and end mill cutters, the v_c values are related to roughing. For finishing, one can increase these values by 20 %.

(Tabular values are averaged values by tool manufacturers and [15])

Table 11.11 Cutting speeds v_c in m/min, feeds f_z in mm per cutting edge and tool angle for cemented carbide-tipped cutter heads. The values for roughing are valid for depths of cut up to $a = 10$ mm.

Material	Type of machining	f_z in mm	v_c in m/min	Tool angle in °				Cemented carbide	
				α	γ	γ_f	λ		
E 295–E 335 C 35–C 45	Roughing	0,2–0,5	100–180	8–12	5–10	–4	–8	P 25 up to P 40	
	Finishing	0,1–0,2	120–200						
E 360 and slightly alloyed steels	Roughing	0,2–0,5	70–140	8–12	5–10	–10	–8		
	Finishing	0,1–0,2	90–180						
Highly alloyed steels die steels	Roughing	0,2–0,4	50–100	8–10	5	–10	–8		
	Finishing	0,1–0,2	70–120						
GE 240–GE 260	Roughing	0,2–0,4	60–100	8–10	5–10	–10	–8		
	Finishing	0,1–0,2	70–120						
GJL 250–GJL 300	Roughing	0,2–0,5	60–120	8–12	0–8	–4	–8		K 10 up to K 20
	Finishing	0,2–0,3	80–140						
CuZn 42–CuZn 37 (Ms 63)	Roughing	0,2–0,4	80–140	8–10	10–12	0	–8		
	Finishing	0,1–0,3	90–150						
Al alloy (9–13 % Si) G–AlSi	Roughing	0,1–0,6	300–600	8–12	12–20	0 up to +15	–4 up to +4		
	Finishing	0,05–0,2	400–900						

Excerpt from reference tables for cutter heads by Krupp Widia-Fabrik, Essen, and Montan-Werke Walter, Tübingen.

For the cutter heads, plan angle ranges from 45° to 90°.

11.10 Examples

Example 1

The workpiece shown in the sketch below (Figure 11.57), made of E 335, is 500 mm long and has to be milled on the upper side with a plain milling cutter in a roughing cut, removal from 46 mm down to 40 mm thickness.

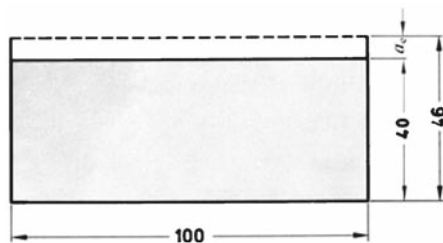


Figure 11.57
Workpiece to be milled

Given:

Speeds available on the milling machine

$$n = 35,5; 50; 71; 100 \dots$$

feed rates v_f adjustable on the milling machine

$$v_f = 16\text{--}2500 \text{ mm/min adjustable infinitely variable machine efficiency } \eta = 0,7$$

Sought for:

1. Selection of tool
2. Machine input power
3. Milling time (machining time) for one workpiece

Approach:

1. Selection of tool:
plain milling cutter type N made of high speed steel DIN 884 (from Table 11.2)
milling cutter diameter $D = B = 100 \text{ mm}$ selected (see 11.5.1.2)
number of cutting edges $z_w = 8$, from Table 11.8 chosen, $\lambda = 40^\circ$ from Table 11.9

2. Machine input power

- 2.1. Angle of approach φ_s

$$\cos \varphi_s = 1 - \frac{2a_e}{D} = \frac{2 \cdot 6 \text{ mm}}{100 \text{ mm}} = 0,88$$

$$\varphi_s = 28,3^\circ$$

- 2.2. Cutting speed

$$v_c \text{ from Table 71} \quad v_c = 22 \text{ m/min chosen}$$

- 2.3. Speed

$$n = \frac{v_c \cdot 10^3}{D \cdot \pi} = \frac{22 \text{ m/min} \cdot 10^3 \text{ mm/m}}{100 \text{ mm} \cdot \pi} = 70,02^{-1}$$

$$n = 71 \text{ min}^{-1} \text{ chosen}$$

from there follows v -real:

$$v_c = D \cdot \pi \cdot n = 0,1 \text{ m} \cdot \pi \cdot 71 \text{ min}^{-1} = 22,3 \text{ m/min}$$

- 2.4. Feed rate of the milling machine table

$$v_f = f_z \cdot z_v \cdot n = 0,18 \text{ mm} \cdot 8 \cdot 71 \text{ min}^{-1} = 102,24 \text{ mm/min}$$

$$v_f = 102 \text{ mm/min selected}$$

$$f_z = 0,18 \text{ mm/cutting edge from Table 11.10 selected}$$

- 2.5. Width of cut

$$b = \frac{100}{\cos \lambda} = \frac{100 \text{ mm}}{\cos 40^\circ} = 130,5 \text{ mm}$$

- 2.6. Average chip thickness

$$h_m = \frac{114,6}{\varphi} \cdot \frac{a_c}{D} \cdot f_z = \frac{114,6^\circ}{28,3^\circ} \cdot \frac{6 \text{ mm}}{100 \text{ mm}} \cdot 0,18 \text{ mm} = 0,044 \text{ mm}$$

- 2.7. Specific cutting force k_c

$$K_{ver} = 1,3 \text{ chosen}$$

K_{ver} is the factor considering tool wear,
for a new tool sharpened for machining, $K_{\text{ver}} = 1$.

$K_v = 1,2$ This factor considers the tool material or the cutting speed
For high speed steel tools, $K_v = 1,2$

$K_{\text{st}} = 1,2$ Compressive factor
correction factor for the rake angle K_γ

$\gamma_{\text{tat}} = 12^\circ$ selected from Table 11.9, $\gamma_0 = 6^\circ$ for steel

$$K_\gamma = 1 - \frac{\gamma_{\text{tat}} - \gamma_0}{100} = 1 - \frac{12^\circ - 6^\circ}{100} = 0,94$$

$$k_c = \frac{(1 \text{ mm})^z}{h_m^z} \cdot k_{\text{cl},1} \cdot K_\gamma \cdot K_v \cdot K_{\text{ver}} \cdot K_{\text{st}}$$

$$= \frac{(1 \text{ mm})^{0,17}}{0,044^{0,17}} \cdot 2110 \text{ N/mm}^2 \cdot 0,94 \cdot 1,2 \cdot 1,3 \cdot 1,2 = 6314,5 \text{ N/mm}^2$$

2.8. Average major cutting force per milling cutter edge

$$F_{\text{cm}} = b \cdot h_m \cdot k_s = 130,5 \text{ mm} \cdot 0,044 \text{ mm} \cdot 6314,5 \text{ N/mm}^2$$

$$F_{\text{cm}} = 36257,8 \text{ N}$$

2.9. Number of cutting edges in contact

$$z_E = \frac{z \cdot \varphi^\circ}{360^\circ} = \frac{8 \cdot 28,3^\circ}{360^\circ} = 0,63$$

2.10. Machine input power

$$P = \frac{F_{\text{cm}} \cdot v_c \cdot z_E}{60 \text{ s/min} \cdot 10^3 \text{ W/kW} \cdot \eta} = \frac{36257,8 \text{ N} \cdot 22,3 \text{ m/min} \cdot 0,62}{60 \text{ s/min} \cdot 10^3 \text{ W/kW} \cdot 0,7}$$

$$P = 11,93 \text{ kW}$$

3. Machining time t_h

Total path L for roughing (11.6)

$$L = l + 3 + \sqrt{D \cdot a_c - a_c^2} = 500 \text{ mm} + 3 \text{ mm} + \sqrt{100 \text{ mm} \cdot 6 \text{ mm} - 6^2 \text{ mm}^2}$$

$$L = 526,74 \text{ mm}$$

machining time t_h

$$t_h = \frac{L \cdot i}{f \cdot n} = \frac{L \cdot i}{v_f} = \frac{526,74 \text{ mm}}{102 \text{ mm/min}} = 5,16 \text{ min}$$

Example 2

The impact surface of a turbine housing made of GJL 250 should be trimmed by surface milling with a cemented carbide-tipped cutter head in a rough cut.

Given:

1. Size of the surface to be milled: 370 mm wide \times 1200 mm long
2. Depth of cut $a_p = 10 \text{ mm}$, $\eta = 0,7$
3. Speeds adjustable on the machine: $n = 45; 63; 90; 125 \dots$
4. Feed rates adjustable on the machine
 $v_f = 16\text{--}2500 \text{ mm/min}$ adjustable infinitely variably.

Sought:

1. Selection of tool
2. Machine input power
3. Machining time

Approach:

1. Selection of tool

Surface cutter head: $\kappa = 75^\circ$; $\alpha = 10^\circ$; $\gamma = 8^\circ$; $\gamma_f = -4^\circ$; $\lambda = -4^\circ$

Cutter head diameter: $D = 1,4 \cdot B = 1,4 \cdot 370 \text{ mm} = 518 \text{ mm}$

$D = 500 \text{ mm}$ selected

Number of teeth $z_w = 26$

(the values were taken from Tables 11.3 and 11.11 or according to Chapters 11.5.1 and 11.5.2 with Figure 11.18).

Lateral offset of the milling cutter:

Distance $A_1 = 0,1 \cdot B = 0,1 \cdot 370 \text{ mm} = 37 \text{ mm}$

Distance $E = D - B - A = 500 \text{ mm} - 370 \text{ mm} - 37 \text{ mm} = 93 \text{ mm}$

Distance $A_2 = B + A_1 = 370 \text{ mm} + 37 \text{ mm} = 407 \text{ mm}$

2. *Machine input power*

- 2.1. Angle of approach

feed motion angle φ_A at the beginning of the cut

$$\cos \varphi_A = 1 - \frac{2 \cdot A_1}{D} = 1 - \frac{2 \cdot 37 \text{ mm}}{500 \text{ mm}} = 0,852 \rightarrow \varphi_A = 31,6^\circ$$

feed motion angle φ_E at the end of the cut

$$\cos \varphi_E = 1 - \frac{2 \cdot A_2}{D} = 1 - \frac{2 \cdot 407 \text{ mm}}{500 \text{ mm}} = 0,682 \rightarrow \varphi_E = 128,9^\circ$$

angle of approach φ_s

$$\varphi_s = \varphi_E - \varphi_A = 128,9^\circ - 31,6^\circ = 97,3^\circ$$

width of cut b

$$b = \frac{a_p}{\sin \kappa} = \frac{10 \text{ mm}}{0,966} = 10,35 \text{ mm}$$

- 2.3. Average chip thickness h_m

$$h_m = \frac{114,6^\circ}{\varphi^\circ} \cdot f_z \cdot \frac{B}{D} \cdot \sin \kappa = \frac{114,6^\circ}{97,3^\circ} \cdot 0,3 \text{ mm} \cdot \frac{370 \text{ mm}}{500 \text{ mm}} \cdot 0,966$$

$$h_m = 0,253 \text{ mm}$$

$$f_z = 0,3 \text{ mm/cutting edge chosen from Table 11.11}$$

- 2.4. Specific cutting force k_c

Correction factor for the rake angle K_γ

$$K_\gamma = 1 - \frac{\gamma_{\text{rat}} - \gamma_0}{100} = 1 - \frac{8 - 2}{100} = 0,94$$

Correction factor for the cutting speed, if using cemented carbide for the cutting edges

$K_v = 1,0$. Chip compression $K_{st} = 1,2$.

The wear factor considering tool wear, K_{ver} , is assumed as $K_{ver} = 1,3$.

$$k_c = \frac{(1 \text{ mm})^2}{h_m^2} \cdot k_{c1,1} \cdot K_\gamma \cdot K_v \cdot K_{ver} \cdot K_{st}$$

$$= \frac{(1 \text{ mm})^{0,26}}{0,253^{0,26}} \cdot 1160 \text{ N/mm}^2 \cdot 0,94 \cdot 1 \cdot 1,3 \cdot 1,2 = 2431,7 \text{ N/mm}^2$$

2.5. Mean major cutting force per cutting edge

$$F_{cm} = b \cdot h_m \cdot k_c = 10,3 \text{ mm} \cdot 0,253 \text{ mm} \cdot 2431,7 \text{ N/mm}^2 = 6336,7 \text{ N}$$

2.6. Number of teeth in contact

$$z_E = \frac{\varphi^\circ \cdot z}{360^\circ} = \frac{97,3^\circ \cdot 26}{360^\circ} = 7,03$$

2.7. Machine input power

$$P = \frac{F_{cm} \cdot v_c \cdot z_E}{60 \text{ s/min} \cdot 10^3 \text{ W/kW} \cdot \eta} = \frac{6336,7 \text{ N} \cdot 100 \text{ m/min} \cdot 7,03}{60 \text{ s/min} \cdot 10^3 \text{ W/kW} \cdot 0,7} = 106 \text{ kW}$$

$v_c = 100 \text{ m/min}$ selected from Table 11.11

As can be seen from the value of the required machine input power, during machining with cutter heads, the maximal metal removal rate is not limited by the feasible cutting capacity of the cutter head, but by the machine input power.

3. *Machining time*

Total path L for roughing during eccentric face milling

$$L = l + 3 + \frac{D}{2} - \sqrt{\left(\frac{D}{2}\right)^2 - B'^2}$$

$$B' = \frac{D}{2} - A_1 = \frac{500 \text{ mm}}{2} - 37 \text{ mm} = 213 \text{ mm}$$

$$L = 1200 \text{ mm} + 3 \text{ mm} + \frac{500 \text{ mm}}{2} - \sqrt{\left(\frac{500}{2}\right)^2 \text{ mm}^2 - 213^2 \text{ mm}^2}$$

$$L = 1322,12 \text{ mm}$$

$$t_h = \frac{L \cdot i}{f \cdot n}$$

$$f = f_z \cdot z_w = 0,3 \text{ mm} \cdot 26 = 7,8 \text{ mm/U}$$

$$n = \frac{v_c \cdot 10^3}{D \cdot \pi} = \frac{100 \text{ m/min} \cdot 10^3 \text{ mm/m}}{500 \text{ mm} \cdot \pi} = 63,66 \text{ min}^{-1}$$

$$n = 63 \text{ min}^{-1} \text{ selected}$$

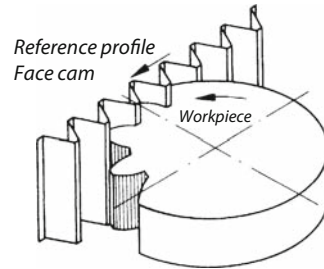
$$t_h = \frac{L \cdot i}{f \cdot n} = \frac{1322,12 \text{ mm} \cdot 1}{7,8 \text{ mm} \cdot 63 \text{ min}^{-1}} = 2,69 \text{ min}$$

11.11 Gear machining techniques

1. Gear cutting by generating processes

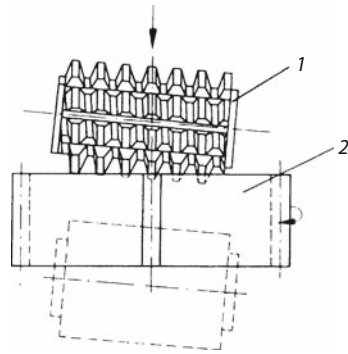
In all gear generating techniques, workpiece and tool carry out a rolling motion. They move in mutual rolling contact like two-toothed gear elements do.

During rolling, the involute of a tool with a straight reference profile is involved, so that the workpiece moves simultaneously. In each position, the cutting edges of the involute profile touch each other so that the gear tooth is shaped by a series of enveloping cuts.



1.1 Gear hobbing

Gear hobbing is a continuous rolling method. The body enveloping the hob is a cylindrical involute worm. Tool and workpiece rotate during the generating motion, while the milling cutter executes the cutting motion as it circles around. To manufacture spur gears, milling cutter and workpiece are shifted in relation to each other in the direction of the workpiece axis, and the generating motion is carried out at the same time.

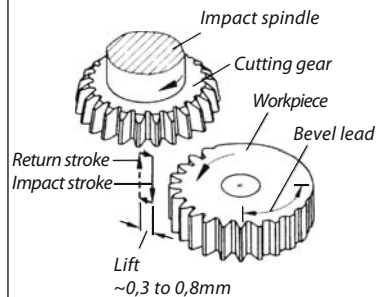


1.2 Gear shaping

Gear shaping is another method involving continuous generation. During gear cutting, the cutting gear and the workpiece roll against each other like the gear and the mating gear of a spur gear. At the same time, the cutter for gear-shaping carries out the cutting motion through its oscillating slotting motion.

In straight-toothed gears, the slotting motion corresponds with the part's axis direction. In helical teeth, the helical cutting gear performs the helical cutting motion according to the helix angle to be generated.

The tool is a straight-toothed- or helical gear, whose flanks are tapered to the back. Thus, the tool orthogonal clearance required for metal cutting is created .

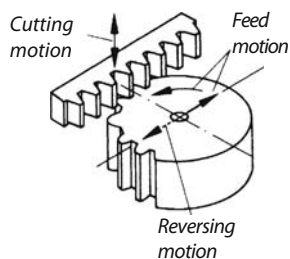


1.3 Gear planing

Gear planing/ slotting is a pitch generating method (group pitch). The workpiece that is to be toothed rolls on the rack-form cutter (plane). The tool performs the cutting motion (vertical movement).

During the return stroke, the rack-form cutter is taken off. After finishing one tooth, the workpiece is rotated by one pitch.

The tool is a rack whose flanks are exposed to the back. It is called a rack-form cutter.



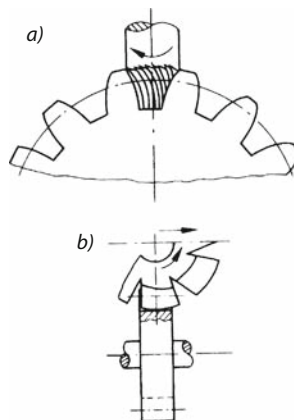
2. Form milling

During form milling, the milling cutter is given the profile of the tooth space to be milled. The rotating milling cutter and the workpiece are shifted against each other in the workpiece axis direction.

When machining a straight-toothed gear, the workpiece does not rotate. Only after finishing a tooth space is it rotated by one pitch (single pitch method).

In helical gears, the workpiece performs a continuous rotation, which corresponds to the helix angle. The single pitch methods are also applied in this case.

Form milling can be done by a slot drill or a side and face milling cutter.

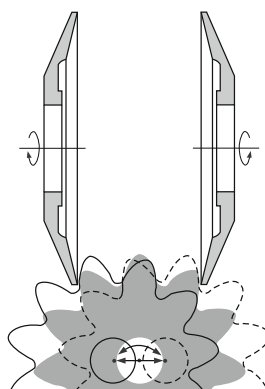


3. Gear grinding

During gear grinding, the involute profile is generated by rolling the gear on two disk-like grinding wheels. During the so-called 0° method, the grinding wheels are allocated in parallel.

The workpiece performs the grinding feed in axial direction, moving forward and back. Pitch is set at the end of feed travel.

In each operation, two gear flanks are ground simultaneously. The cutting infeed results from moving the two grinding wheels together.



12 Broaching

12.1 Definition

Broaching is a metal cutting technique with a multi-edged tool in which the tool performs the cutting motion. This method functions without any feed motion due to the offset of the cutting teeth on the broaching tool.

The material is removed in one stroke (pulling or pushing) with the broaching tool, called the broach.

12.2 Broaching methods

In broaching, two working procedures – internal- and external broaching - are distinguished.

12.2.1 Internal broaching

During internal broaching, the broaching tool is brought into the premachined opening of the workpiece. Working motion then begins, whereby the broach, equipped with many cutting blades, is pulled or pushed through. The broach contour (square, hexagon, etc.) is generated in the workpiece opening.

Figure 12.1 elucidates the configuration of workpiece and tool during broaching.

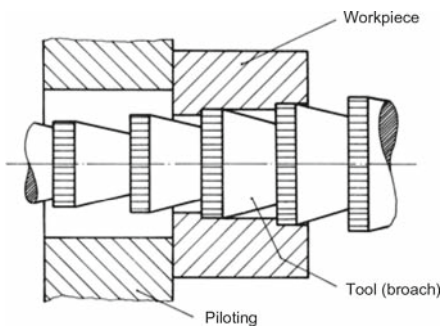


Figure 12.1
Broaching principle

12.2.2 External broaching

During external broaching, the broaching tool finishes a premachined outer workpiece contour, such as the opening of a forged open-end wrench.

12.3 Application of the broaching techniques

12.3.1 Internal broaching

Internal broaching is applied to generate openings of different shapes. Thus, for example, serrations, taper bushings for splines, and spline profiles for movable gears are created with this method. Some typical examples are seen in Figure 12.2.



Figure 12.2
Broaching profiles for internal broaching
(photo by Karl Klink, Niefern)

As a rule, broaching is used if high accuracy to shape and size is demanded in addition to high surface quality. For this reason, broaching is sometimes used instead of reaming to generate holes.

Broaching is an economical procedure since it is possible to produce very sophisticated geometries that require no further reworking very quickly and with a single stroke.

The generation of a spline profile in internal broaching is illustrated in Figure 12.3.

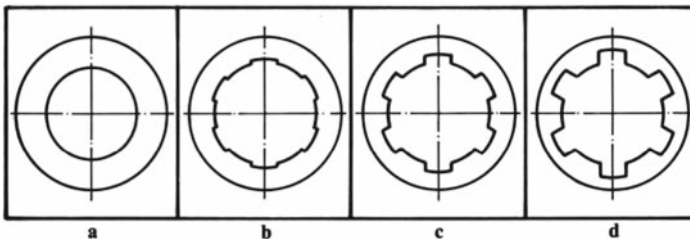


Figure 12.3
Generation of an internal spline during internal broaching
a - before; b and c – during; d – at the end of the broaching procedure

12.3.2 External broaching

External broaching is the method used for the generation of external profiles. However, this method is also used for the manufacturing of shaped grooves, such as Christmas tree-shaped grooves (Figure 12.4c), in which the turbine blades are mounted in turbine wheels.

External broaching is also applied for machining of external teeth (Figure 12.4b) and guiding surfaces (Figure 12.4d), as well as guide grooves and similar items.

Figure 12.4 shows some typical workpieces for external broaching.

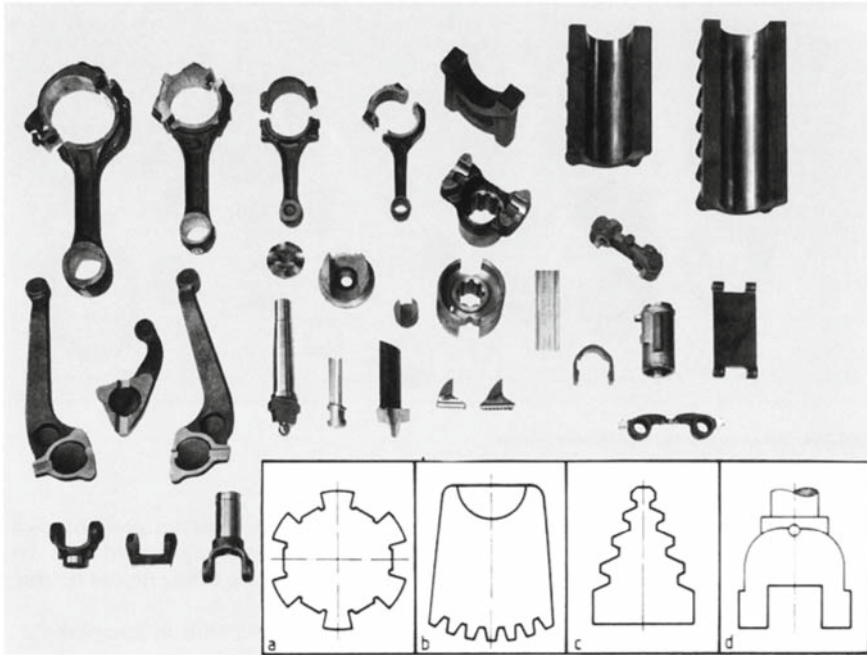


Figure 12.4
Broaching profiles to be produced by external broaching
(photo by Karl Klink, Niefern)

12.4 Achievable accuracy values

12.4.1 Accuracy to size

The accuracy values that can definitely be achieved with internal- and external broaching range from

IT 7 to IT 8.

However, with more effort, it is also possible to achieve

IT 6.

For internal broaching, permissible tolerances for hubs and hub-like profiles can be taken from the following DIN sheets:

<i>DIN</i>	<i>Profile type</i>
5465	Splines with straight-lined flanks
5471/72	Internal splines with 4 or 6 splines
5480	Involute splines
5481	Serrations
5482	Internal- and external splines with involute toothing

12.4.2 Surface quality

The final finishing tooth that cuts in the offset at a depth of $h = 0,01$ mm has a substantial effect on surface quality.

Furthermore, reserve teeth are included in internal broaching. These teeth improve the surface by regrooving and shaving.

During the generation of profiled surfaces with all the teeth of a broaching tool or of straight surfaces by broaching tools with lateral offset, the surface is influenced by the minor cutting edges of these tools. The surface roughness values R_t that can be achieved during broaching of mild steels range from

$$R_t = 6,3 \text{ to } 25 \text{ } \mu\text{m}$$

High surface qualities can also be achieved in the case of easily broached free cutting steels and materials for casting.

Acceptable broaching results may also be expected from case hardening- and tempering steels, if a homogeneous ferrite-, perlite distribution is available for normally annealed material.

12.5 Calculation of force and power

During broaching, the cutting edge angle α is

$$\alpha = 90^\circ \quad \text{for internal broaching and}$$

$$\alpha = 90 - \lambda \quad \text{for external broaching}$$

$$\lambda \text{ in } ^\circ \quad \text{tool cutting edge inclination (Figure 12.9).}$$

From this, we may conclude:

12.5.1 Width of cut b (Figure 12.5)

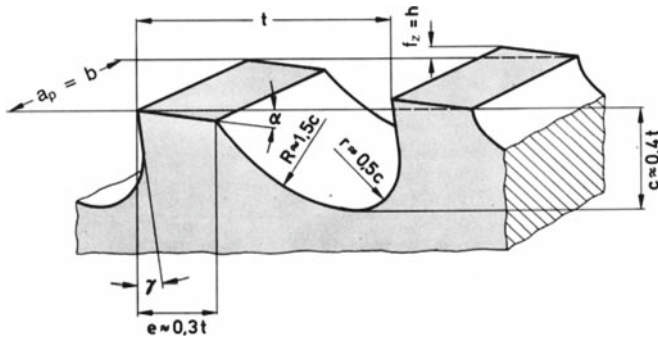


Figure 12.5

Cutting variables during broaching

t pitch, e tooth back thickness, c tooth space depth, r rake face radius, f_z stepping of the cutting edges (feed per cutting edge), a_p broach width

$$b = a_p \quad \text{for internal broaching}$$

$$b = \frac{a_p}{\cos \lambda} \quad \text{for external broaching (see Figure 12.9)}$$

a_p in mm broach width

b in mm width of cut

λ in $^\circ$ tool cutting edge inclination (Figure 12.9)

12.5.2 Thickness of cut h

$$h = f_z$$

h in mm thickness of cut

f_z in mm feed per cutting edge

12.5.3 Specific cutting force

$$k_c = \frac{(1 \text{ mm})^z}{f_z^z} \cdot k_{c1,1} \cdot K_\gamma \cdot K_{\text{ver}} \cdot K_v \cdot K_{\text{st}}$$

K_c in N/mm^2 specific cutting force

$k_{c1,1}$ in N/mm^2 specific cutting force related to $h = b = 1 \text{ mm}$

K_γ correction factor for the rake angle γ

K_{ver} correction factor for tool wear

$$K_{\text{ver}} = 1,3$$

K_{st} correction factor for chip compression

$$K_{\text{st}} = 1,1$$

K_v correction factor for the cutting speed

$K_v = 1$ for cemented carbide cutting edges

$K_v = 1,15$ for cutting edges made of high speed steel

$$K_\gamma = 1 - \frac{\gamma_{\text{tat}} - \gamma_0}{100}$$

γ_{tat} = real rake angle
 $\gamma_0 = 6^\circ$ for steel
 $\gamma_0 = 2^\circ$ for grey cast iron

12.5.4 Major cutting force per cutting edge

$$F_{cz} = a_p \cdot f_z \cdot k_c$$

F_{cz} in N major cutting force per cutting edge
 a_p in mm broach width
 f_z in mm feed per cutting edge
 A in mm² sectional area of chip ($A = a \cdot f_z$)

12.5.5 Number of teeth in contact

$$z_E = \frac{l}{t}$$

z_E number of teeth in contact
 l in mm broaching length in the workpiece (see Figure 212)
 t in mm tothing pitch

12.5.6 Tothing pitch

Pitch t of the broach is understood as the distance from cutting edge to cutting edge (Fig. 12.5).

Pitch should be selected in a way that at least 2 teeth are in contact. However, care should also be taken to ensure that too many teeth are not in contact; otherwise, the required broaching force would exceed the transforming capacities of the broaching cross section or the stroke-related force of the broaching machine.

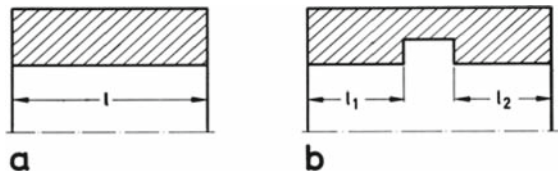
To avoid vibrations that result in chatter marks in broaching, pitch is varied from tooth to tooth by 0,1 to 0,3 mm.

Broach length l corresponds to the length to be broached in the workpiece. For a workpiece with throughhole, l corresponds to the length of the workpiece. If the workpiece has a recess (Figure 12.6b), then l is composed of the partial lines l_1 and l_2 .

$$l = l_1 + l_2$$

Minimal permissible pitch can be determined from the following criteria.

Figure 12.6
 Workpiece length for broaching
 a) workpiece with throughhole,
 b) workpiece with offset hole



12.5.6.1 Minimal permissible tooth pitch according to the force available in the broaching machine

$$F_c \leq F_M$$

$$F_c = F_{cz} \cdot z_E$$

From $a_p \cdot f_z \cdot k_c \cdot z_E \leq F_M$ we obtain:
$$z_{E_{\max}} = \frac{F_M}{a_p \cdot f_z \cdot k_c}$$

$$t_{\min} = \frac{l}{z_{E_{\max}}} = \frac{l \cdot a_p \cdot f_z \cdot k_c}{F_M}$$

t_{\min}	in mm	minimal permissible tooth pitch
l	in mm	broaching length in the workpiece
$z_{E_{\max}}$		maximal number of teeth in contact
F_M	in N	broaching force (stroke) of the broaching machine
a_p	in mm	broach width
f_z	in mm	feed per cutting edge
F_c	in N	major cutting force

12.5.6.2 Minimal permissible tooth pitch according to the required chip space

$$t_{\min} \approx 3 \cdot \sqrt{l \cdot f_z \cdot C}$$

t_{\min}	in mm	minimal permissible tooth pitch
l	in mm	broaching length in the workpiece
C		chip space number

In this empiric equation, the required chip space is considered via chip space number C .

Table 12.1 Chip space number C

Material	Chip space number C			
	Internal broach		External broach	
	Flat	Round	with	
			Offset in depth	Lateral offset
Steel	5–8	8–16	4–10	1,8–6
Cast steel	6	12	7	4
Grey cast iron	6	12	7	4
Non-ferrous metals	3–7	6–14	3–7	1–5

(excerpt from reference tables by Hoffmann, Pforzheim)

12.5.6.3 Minimal permissible tooth pitch according to the permissible force the broach cross-section is able to transform

$$F_c \leq F$$

$$F_c \leq A_0 \cdot \sigma_{zul}$$

In this case, the major cutting force F_c required for broaching must not exceed the permissible force F that the core cross-section of the broach is able to transform.

From this, we derive:

$$t_{\min} = \frac{l \cdot a_p \cdot f_z \cdot k_c}{A_0 \cdot \sigma_{zul}}$$

t_{\min}	in mm	minimal permissible tooth pitch
l	in mm	broaching length in the workpiece
A_0	in mm ²	core cross-section of the broach
σ_{zul}	in N/mm ²	permissible broaching stroke stress of the broach material

Since the broach is dimensioned by the manufacturer, the user of the broach need not do this confirmative calculation.

12.5.7 Major cutting force

$$F_c = a_p \cdot f_z \cdot k_c \cdot z_E$$

F_c	in N	major cutting force
a_p	in mm	broach width
f_z	in mm	feed per cutting edge
k_c	in N/mm ²	specific cutting force
z_E		number of cutting edges in contact

12.5.8 Machine input power

$$P = \frac{F_c \cdot v_c}{60 \text{ s/min} \cdot 10^3 \text{ W/kW} \cdot \eta_M}$$

P	in kW	machine input power
F_c	in N	major cutting force
v_c	in m/min	cutting speed
η_M		machine efficiency

12.6 Calculation of the machining time

For broaching, the machining time is composed of the individual times for cutting motion and return stroke.

$$t_h = \frac{H}{v_c} + \frac{H}{v_r}$$

$$t_h = \frac{H(v_c + v_r)}{v_c \cdot v_r}$$

t_h	in min	machining time for one work cycle (cutting- and return stroke)
H	in m	required stroke
v_c	in m/min	cutting speed
v_r	in m/min	return speed

12.6.1 Work cycle during internal broaching (Figure 12.7)

For internal broaching, work cycle H (Figure 12.7) is composed of the following parameters:

$$H = 1,2 \cdot l + a_2 + a_3 + l_2$$

- H in mm stroke during internal broaching
- l in mm broaching length in the workpiece (see Figure 12.6, Chapter 12.5.6)
- a_2 in mm length of the cutting portion
- a_3 in mm pilot length
- l_2 in mm rear support length

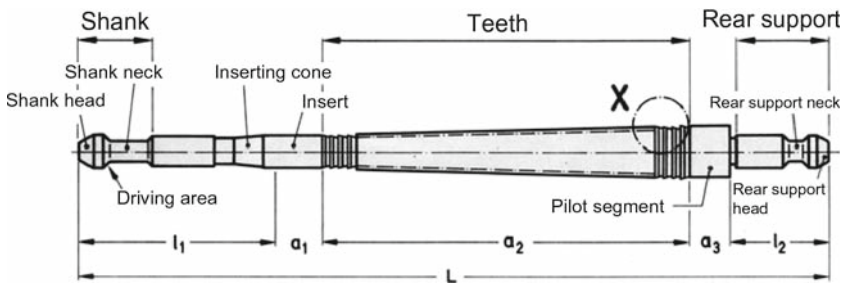


Figure 12.7

Broach components

l_1 shank, a_1 pilot, a_2 cutting portion, a_3 pilot, l_2 rear support, L total length detail X see Figure 12.9

12.6.2 Working stroke during external broaching (Figure 12.8)

$$H = 1,2 \cdot L + l_a + w$$

- H in mm stroke during external broaching
- L in mm tool length
- l_a in mm thickness of the closing plate
- w in mm workpiece height

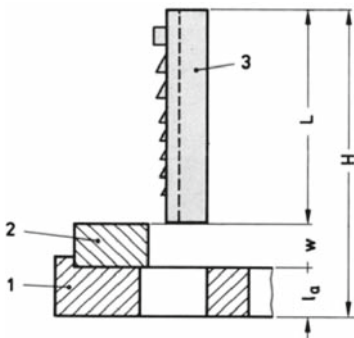


Figure 12.8

External broaching – working principle
1 closing plate, 2 workpiece, 3 broaching tool

12.6.3 Length of the cutting portion (Figure 12.7)

$$a_2 = t_1 \cdot z_1 + t_2 \cdot (z_2 + z_3)$$

a_2	in mm	length of the cutting portion
t_1	in mm	pitch of the roughing teeth
t_2	in mm	pitch of finishing- and calibrating teeth
z_1		number of roughing teeth
z_2		number of finishing teeth
z_3		number of calibrating teeth

(see also Chapter 12.7.2 Broach teeth design)

12.7 Broaching tools

12.7.1 Broach – blade geometry

On broaches, rake angle and tool orthogonal clearance (Figure 12.9) have the same effect as on the turning tool (see Chapter 2.4).

Rake face chamfers reinforce the wedge and only slightly diminish the positive properties of greater rake angles. Due to complicated grinding, broaches are generally made without any rake face chamfers.

Flank wear lands with a land angle of the flank from 0° to 0,5° and a land width of 0,5 mm have only finishing- and calibrating teeth. Only small land angles of the flank with small land width are selected in order to maintain accuracy to size of the broach even in the case of repeated re-sharpening.

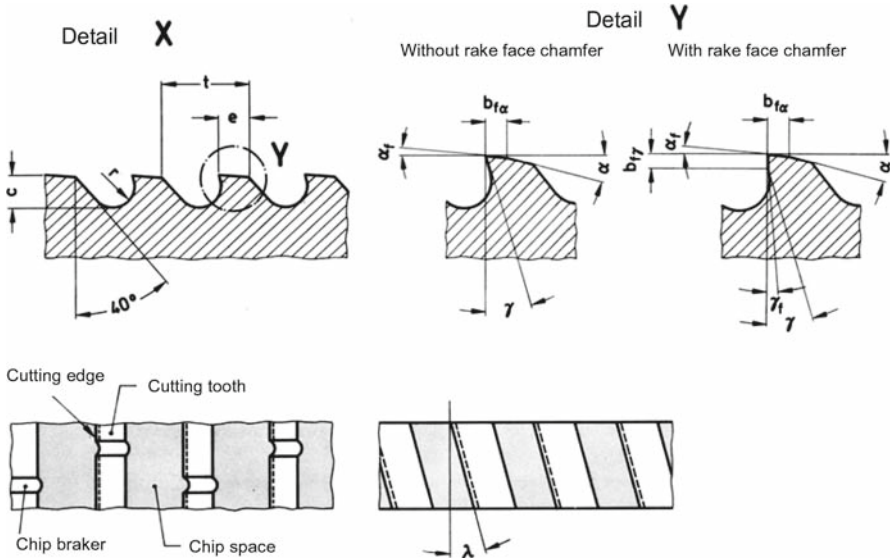


Figure 12.9 Cutting edge geometry of a broach according to Figure 12.7, at the bottom right, cutting edges of a broach with inclined blades

Table 12.2 below shows the order of magnitude of the angles on broaching tools.

Table 12.2 Rake angle and tool orthogonal clearance on broaches

Material	α in $^{\circ}$	γ in $^{\circ}$
E 295–E 335 C 22–C 35	3	18–25
E 360 C 60	4	15–20
Quenched and subsequently tempered steel 1000 N/mm ²	4	12–18
Tool steel	4	12–18
Grey cast iron	3	8–15
Al alloy. 9–13% Si	4	18–25
Brass, bronze	4	5–20

In internal broaches, tool cutting edge inclination λ is defined as $\lambda = 0^{\circ}$ to avoid high cost for regrinding.

For external broaches, chosen tool cutting edge inclination ranges from 3° to 20° . Inclination of cutting edges brings the following advantages:

1. gradual approach contact of the blade,
2. lower cutting forces – no pulse-like load that could result in vibrations,
3. easier chip removal sidewise.

For external broaching, the following values are recommended for the tool cutting edge inclination:

Surface broaching in offset in depth $\lambda < 20^{\circ}$

Profile broaching in offset in depth $\lambda < 3^{\circ}$

Lateral offset $\lambda < 15^{\circ}$

12.7.2 Broach teeth design

The tooth space (Figure 12.9) is formed by the 3 parameters

tooth space depth c

rake face radius r

pitch t .

The tooth space has to be shaped so that the chips necessarily roll up (Figure 12.10). Chip clogging in the tooth space results in breaking off of teeth and generates jams and inexact contours on the workpiece's outgoing side.

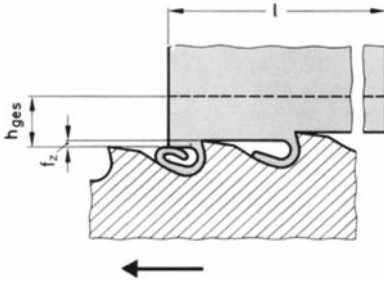


Figure 12.10
Formation of the tooth space

12.7.2.1 Minimal permissible pitch t

is calculated according to the equation under 12.5.6.2 and given in mm.

$$t_{\min} = 3 \cdot \sqrt{l \cdot f_z \cdot C}$$

C chip space number
 l in mm broaching length in the workpiece

12.7.2.2 Tooth space depth c

(Figure 12.9) is taken from:

$$C \approx 0,35 \cdot t$$

c in mm tooth space depth
 t in mm pitch

12.7.2.3 Tooth back thickness e

and rake face radius are to be selected in the ranges given below

$$e = 1,1 - 8 \text{ mm}$$

$$r = 0,8 - 5 \text{ mm}$$

Both values can be calculated in good approximation

$$\begin{array}{l} e \approx 0,3 \cdot t \\ r \approx 0,6 \cdot c \end{array}$$

The cutting tooth parameters are defined in DIN 1416.

Table 12.3 Cutting tooth sizes (excerpt from DIN 1416)

Pitch t in mm	Tooth space depth c in mm	Tooth back thickness e in mm	Rake face radius r in mm
3,5	1,2	1,1	0,8
4	1,4	1,2	0,8
4,5	1,6	1,4	1,0
5	1,8	1,6	1,0
6	2,2	2,0	1,6
7	2,5	2,2	1,6
⋮	⋮	⋮	⋮
⋮	⋮	⋮	⋮
25	9	8	5

12.7.2.4 Tooth offset

Offset is understood as the chip removal predefined by the allocation of teeth (Figure 12.11). The tooth offset corresponds to the thickness of cut h . Since the plan angle during broaching is 90° , there is

$$h = f_z$$

f_z in mm feed per cutting edge
 h in mm thickness of cut

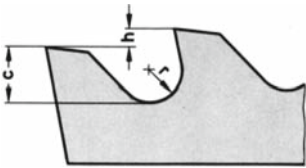


Figure 12.11
Tooth offset

We distinguish between offset in depth and lateral offset.

Offset in depth means that the feed direction is orthogonal to the broaching surface.

Lateral offset is available if the broaching surface is machined from the side. Permissible thickness of cut is shown in Table 12.4.

Table 12.4 Depth- and lateral offsets during external broaching

Material	Thickness of cut h per tooth in mm		
	Offset in depth		Lateral offset
	Roughing	Finishing	
S 275 JR–E 360 C 22–C 60	0,06–0,15	0,01–0,025	0,08–0,25
Quenched and tempered steel 1000 N/mm ² tool steel	0,04–0,10	0,01–0,025	0,08–0,25
Grey cast iron	0,08–0,2	0,02–0,04	0,29–0,6
Al alloy 9–13% Si	0,1–0,2	0,02	not applied
Brass, bronze	0,1–0,3	0,02	not applied

Table 12.5 Depth- and lateral offset during internal broaching

Material	Thickness of cut h per tooth in mm				
	Plane-broaching tool		Round-broaching tool		Profile broach- ing tool
	Roughing	Finishing	Roughing	Finishing	
Steel Cast steel	0,04–0,1	0,01–0,025	0,01–0,03	0,0025–0,005	0,02–0,08
GG Non-ferrous metals	0,05–0,15	0,02–0,04	0,02–0,04	0,01–0,02	0,04–0,1

(excerpt from reference tables by Kurt Hoffmann, Pforzheim)

12.7.2.5 Number of cutting edges (Figure 12.10)

a) *Total tooth number*

$$z_w = \frac{h_{ges}}{f_z}$$

z_w total tooth number of the broach
 h_{ges} in mm machining allowance (Figure 12.10)
 f_z in mm feed per cutting edge = thickness of cut h

b) *Tooth number z_2 for finishing*

For finishing, 5 teeth are used on average.

$$z_2 = 5 \text{ teeth}$$

z_2 number of teeth for finishing

c) *Number of teeth z_1 for roughing*

$$z_1 = \frac{h_{\text{ges}} - 5 \cdot f_{z2}}{f_{z1}}$$

z_1		tooth number for roughing
h_{ges}	in mm	machining allowance
f_{z1}	in mm	feed per cutting edge for roughing
f_{z2}	in mm	feed per cutting edge for finishing

d) For calibration, one can also assume 5 teeth. However, since the calibration teeth only smooth instead of removing any allowance, this tooth number is not integrated into the calculation of z_1 .

12.7.2.6 Total length of the internal broach (Figure 12.7)

$$L = l_1 + a_1 + a_2 + a_3 + l_2$$

L	in mm	total length of the internal broach
l_1	in mm	shank length
a_1	in mm	pilot length
a_2	in mm	length of the cutting portion
a_3	in mm	length of the rear pilot
l_2	in mm	length of the rear support

The length of the external broach arises from the length of the cutting portion or the length of the cutting portion's mounting.

The design types of shanks, rear supports (Figure 12.7) and pilots are defined in DIN 1415 sheet 1.

Table 12.6 shows an excerpt from DIN 1415 for round shanks and rear supports.

Table 12.6 Length of round shanks l_1 and rear supports l_2 in mm as a function of the broach diameter d in mm (Figure 12.7)

d in mm	Shank length l_1 in mm	Rear support length l_2 in mm
20–25	180	190
28–40	200	125
⋮	⋮	⋮
⋮	⋮	⋮
100	360	200

excerpt from DIN 1415 sheet 1 and sheet 4

12.7.2.7 Broaches - design types

A variety of broach forms is given in Figure 12.12.

For difficult profile types, the external broach is composed of several cutting portions.

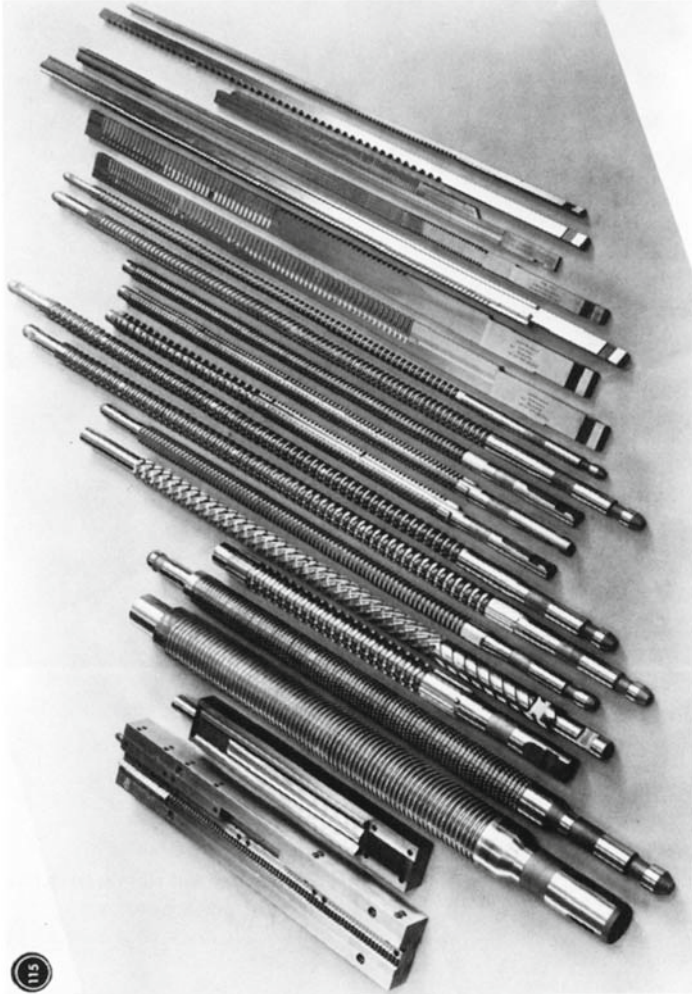


Figure 12.12
Broach types for internal- and external broaching
(photo by Karl Klink, Niefern)

Figure 12.13 elucidates a broaching tool for lateral machining composed of circular cutting portions.

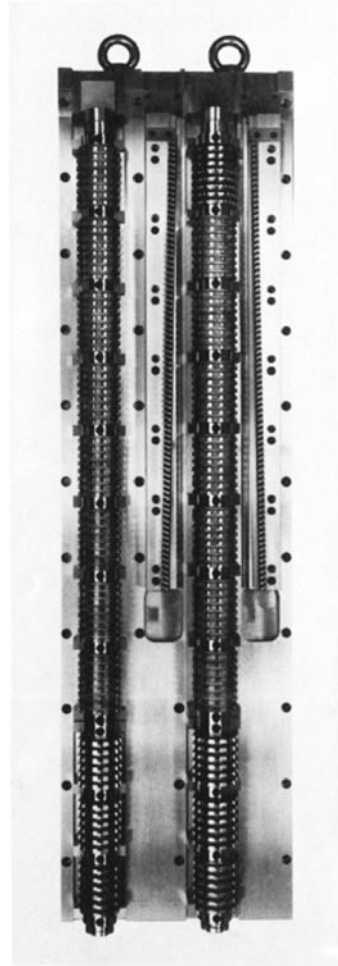


Figure 12.13
Tools with inserted cutting portions with
straight-lined and circular contours
(photo by Karl Klink, Niefern)

12.7.3 Materials for broaching tools

Broaching tools are primarily made of high speed steel. Preferentially used materials are shown below:

<i>Material No.</i>	<i>DIN name</i>	<i>according to EN 96</i>
1.3348	S 2 - 9 - 2	HS 2 - 9 - 2
1.3343	SC 6 - 5 - 2	HS 6 - 5 - 2
1.3243	S 6 - 5 - 2 - 5	HS 6 - 5 - 2 - 5

Cemented carbide is used in addition to high speed steels. In the cemented carbide tools, the backing material is made of tool steel. The cemented carbide cutting edges are inserted into the backing material.

To attach cemented carbide blades, as with the turning and milling tools, there are several possibilities. The blades may either be hard soldered or mounted on the backing material by clamping connections.

Figure 12.14 shows the principle of a clamping connection via clamping wedge.

Figure 12.15 elucidates a broach with inserted cemented carbide blades.

In these cutting portions (Figure 12.16), the cemented carbide tips are hard soldered.

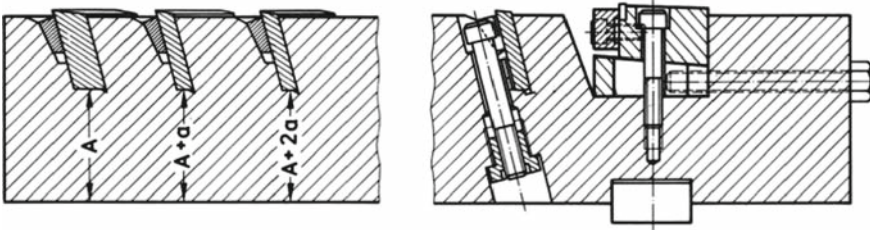


Figure 12.14

Mounting of the cemented carbide blades with a clamping wedge

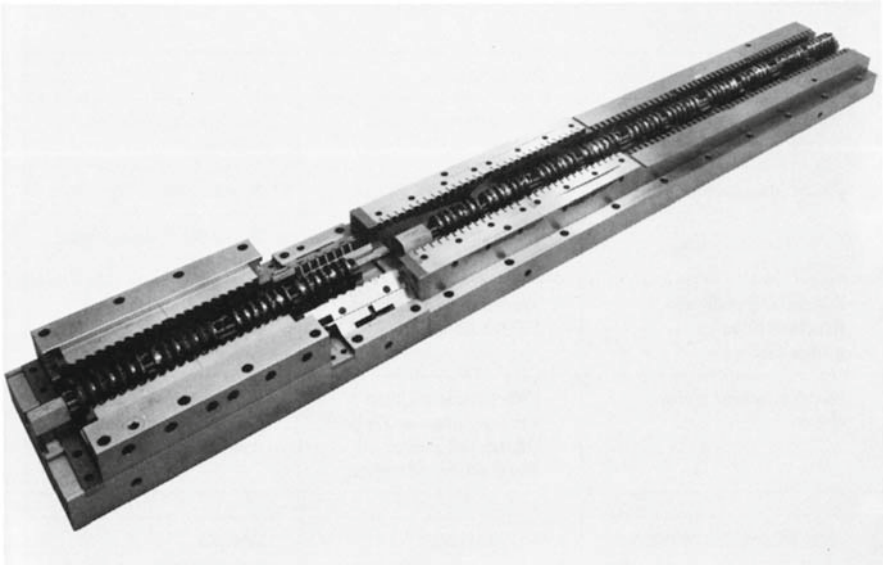
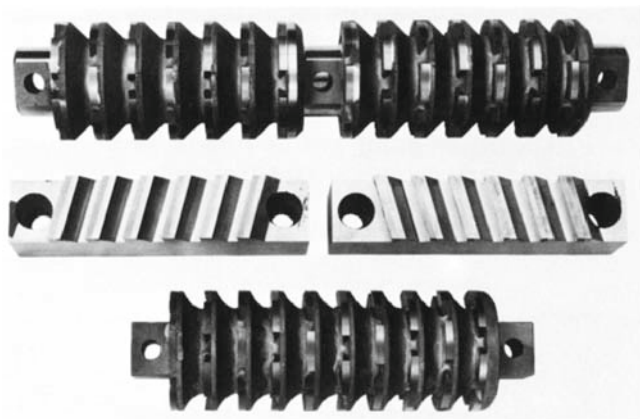


Figure 12.15

Broach tipped with cemented carbide blades
(*photo by Karl Klink, Niefern*)

**Figure 12.16**

Cutting portions with hard soldered cemented carbide tips
(photo by Karl Klink, Niefern)

12.8 Failures during broaching

Table 12.7 Failures and corresponding reasons

12.8.1 Tool failure		
Consequence for the tool	Reason for the failure	Remedy
Tool cutting edge dulls prematurely	Tooth pitch too small	Select greater tool pitch
Teeth break off	Tooth space too small	Increase tooth space
	Form of tooth space does not conform to material	Change form of tooth space
Broach snaps out, fractured surface with rough structure	Tool was overheated during hardening	Check hardening procedures
Broaching machine stops	Tooth pitch too small Too many teeth in contact Broaching force greater than broaching stroke force of the machine	Increase tooth pitch Decrease teeth offset
One surface on workpiece not exact	Internal broach (4-hedral) dull on one side	Regrind broach
Surfaces on the workpiece (internal broaching) machined unevenly	Workpiece clamping instable	Improve tightening
Outgoing side of an internally broached workpiece jammed	Tooth space too small	Increase tooth space
	Pitch too low	Increase tooth space
Hole with chatter marks	All teeth have identical pitch	Use tool with heterogeneous tooth pitch

12.8.2 Workpiece failures		
Consequences for the workpiece	Reason for the failure	Remedy
Chatter marks with great distance between shafts	Rest of the workpiece not angular to the hole	Check rest
Workpiece inexact Jamming on the outgoing side of the workpiece	Soft marks in the workpiece material	Check workpiece material and change, if necessary

12.9 Reference tables

Table 12.8 Cutting speeds v in m/min for broaching [52]

Material	Internal broaching	External broaching
S 275 JR-E 335	4–6	8–10
E 360 and slightly alloyed steels	2–3	6–8
Alloyed steels up to 1000 N/mm ²	1,5–2	4–6
Cast steel	2–2,5	5–7
Gray cast iron	2–3	5–7
Brass, bronze	3–4	10–12
Al alloys	4–6	12–15

Table 12.9 Reverse speed v_r in m/min of the broaching machine

$$v_r = 12 - 30 \text{ m/min}$$

12.10 Calculation example

The task is to simultaneously generate 2 opposite grooves in a pulley made of E 360, hub length 100 mm (see sketch). An internal broach is to be used.

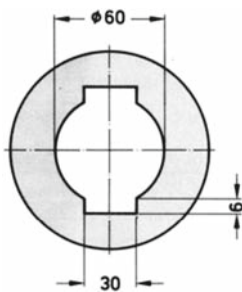


Figure 12.17
Pulley

Given:

Maximal broaching stroke force of the internal broaching machine $F_M = 200 \text{ kN}$

Sought:

1. Tooth pitch
2. Tooth number for roughing and finishing
3. Length of the cutting portion
4. Number of teeth being in contact
5. Broaching force
6. Comparison of broaching force and machine pulling capacity
7. Machining time for one workpiece

Approach:

1. Tooth pitch

Tooth pitch is calculated according to the required chip space.

$$t_{\min} = 3 \cdot \sqrt{l \cdot f_z \cdot C}$$

chip space number C selected from Table 12.1: $C = 7$

$f_z = h$ is selected from offset table 77

$f_{z1} = h_1 = 0,1$ mm for roughing

$f_{z2} = h_2 = 0,02$ mm for finishing

Roughing:

$$t_{\min_1} = 3 \cdot \sqrt{100 \text{ mm} \cdot 0,1 \text{ mm} \cdot 7} = 25,09 \text{ mm} \rightarrow 25 \text{ mm selected}$$

Finishing:

$$t_{\min_2} = 3 \cdot \sqrt{100 \text{ mm} \cdot 0,02 \text{ mm} \cdot 7} = 11,22 \text{ mm} \rightarrow 11 \text{ mm selected}$$

2. Tooth numbers for roughing, finishing and calibrating
 - 2.1. Five teeth are assumed for finishing

$z_2 = 5$ teeth
 - 2.2. For roughing

$$z_1 = \frac{h_{\text{ges}} - 5 \cdot f_{z2}}{f_{z1}}$$

Groove depth is 6 mm. It corresponds to allowance h_{ges}

$$z_1 = \frac{6 \text{ mm} - 5 \cdot 0,02 \text{ mm}}{0,1 \text{ mm}} = 59 \text{ teeth}$$

- 2.3. For calibrating, 5 teeth are assumed

$z_3 = 5$ teeth

For calibrating, the same pitch as for finishing is selected.

3. Length of the broach's cutting portion a_2

$$a_2 = t_1 \cdot z_1 + t_2 \cdot (z_2 + z_3)$$

$$a_2 = 22 \text{ mm} \cdot 59 + 11 \text{ mm} \cdot (5 + 5) = 1408 \text{ mm}$$

4. Number of teeth in contact

Since the maximal force appears for roughing, pitch for roughing is used to determine z_E .

$$z_E = \frac{l}{t} = \frac{100 \text{ mm}}{25 \text{ mm}} = 4 \text{ teeth}$$

5. Broaching force

5.1. Specific cutting force

$$k_c = \frac{(1 \text{ mm})^2}{f_z^2} \cdot k_{c1,1} \cdot K_v \cdot K_{st} \cdot K_{ver} \cdot K_\gamma$$

$$K_v = 1,15; K_{st} = 1,1; K_{ver} = 1,3$$

$$K_\gamma = 1 - \frac{15^\circ - 6^\circ}{100} = 0,91$$

$$k_{c1,1} \text{ from Table 1.1 and } \gamma_{lat} = 15^\circ \text{ from Table 12.2}$$

$$k_c = \frac{(1 \text{ mm})^{0,3}}{(0,1 \text{ mm})^{0,3}} \cdot 2260 \text{ N/mm}^2 \cdot 1,15 \cdot 1,1 \cdot 1,3 \cdot 0,91$$

$$k_c = 6764,1 \text{ N/mm}^2$$

5.2. Major cutting force

Since 2 grooves are broached at the same time, F_s has to be multiplied with factor 2

$$F_c = a_p \cdot f_{z1} \cdot k_c \cdot z_E \cdot 2$$

$$F_c = 30 \text{ mm} \cdot 0,1 \text{ mm} \cdot 6764,1 \text{ mm}^2 \cdot 4 \cdot 2 = 162338,4 \text{ N}$$

$$F_c = 162,3 \text{ kN}$$

6. Comparison of broaching force F_c and machine pulling capacity F_M

$$F_M > F_c$$

$$200 \text{ kN} > 162 \text{ kN}$$

Since the machine pulling capacity F_M is greater than the required broaching force, the machine can be used for this job.

7. Confirmatory calculation of the load due to broaching stroke on the endangered broach cross-section

$$d_R = 38 \text{ mm (DIN 1415)}$$

$$A_0 = \frac{\pi}{4} \cdot d_R^2 = \frac{\pi}{4} \cdot 38^2 \text{ mm}^2 = 1134 \text{ mm}^2$$

$$\sigma = \frac{F_s}{A_0} = \frac{162 \cdot 10^3 \text{ N}}{1134 \text{ mm}^2} = 142,8 \text{ N/mm}^2$$

$$\sigma_{zul} = 250 \text{ N/mm}^2 \text{ for high speed steel}$$

$\sigma < \sigma_{zul}$. For this reason, the work can be performed with this broach from the perspective of the broaching tool.

8. Machining time

8.1. Working stroke for internal broaching

$$H = 1,2 \cdot l + a_2 + a_3 + l_2$$

$$l_2 = 125 \text{ mm from Table 12.6}$$

$$a_3 = 40 \text{ mm assumed}$$

$a_2 = 1408$ mm calculated under 3.

$l = 100$ mm hub length given in this task

$$H = 1,2 \cdot 100 \text{ mm} + 1408 \text{ mm} + 40 \text{ mm} + 125 \text{ mm} = 1693 \text{ mm}$$

8.2. Machining time

$$v_c = \frac{H(v_c + v_r)}{v_c \cdot v_r}$$

$v_c = 3$ m/min selected from Table 12.8

$v_r = 20$ m/min assumed (see Table 12.9)

$$t_h = \frac{1,693 \text{ m} \cdot (3 \text{ m/min} + 20 \text{ m/min})}{3 \text{ m/min} \cdot 20 \text{ m/min}} = 0,65$$

The CD-ROM attached to this book shows a practical example of machining a keyway by broaching in the lab of the University of Applied Sciences HTW Dresden and broaching of a Christmas tree-like profile to attach turbine blades.

13 Grinding

13.1 Definition

Grinding is a metal cutting procedure in which a multi-edged tool, whose cutting edges are geometrically undefined, removes the chips.

During grinding, the tool carries out the cutting motion. The cutting speeds commonly used in grinding are approximately 20 times those used in turning (25 to 45, sometimes up to 120 m/s). The feed movement is executed as a function of the cutting technique, the tool or the workpiece.

The grinding techniques are categorised according to the workpiece shape - in face- and cylindrical grinding, or according to component mounting - as grinding between centres or centreless grinding. It would also make sense to further subdivide these methods according to their ranges of application, such as grinding of slide ways or tools.

The grain cutting edges in the grinding tool may be bonded (grinding wheel, separating disk, grinding belt, honing stone) or loose (lapping). Abrasive cutting is described in Chapter 14, whereas abrasive belt grinding with grinding belts is explained in Chapter 15. Honing is illustrated in Chapter 16, short stroke honing (super finishing) in Chapter 17 and lapping is dealt with in Chapter 18.

13.2 Grinding techniques

13.2.1 Flat grinding

Plane or flat grinding is the grinding of plane surfaces. During flat grinding, the tool performs the cutting motion, whereas the workpiece executes the feed motion. The grinding procedure can be performed by the circumference or face of the grinding tool. Consequently, the following types are distinguished:

13.2.1.1 Circumferential grinding

In circumferential grinding (Figure 13.1), the wheel spindle is in horizontal position. The machine table with the workpiece travels back and forth in a straight line.

As a rule, the lateral feed per stroke is carried out by the table. Machines with a rotary table are an alternative. In these machines, the workpiece moves in a circle on a face chuck, and the lateral feed is performed by the grinding tool.

Since the grinding wheel contacts the workpiece only on a small portion of its circumference during circumferential grinding, the metal removal rate is limited for these methods. Feed and in-feed values are given in Tables 13.17 and 13.18.

Using special wheels and appropriate machines, the full-width grinding method is competitive with milling.

13.2.1.2 Face grinding

In face grinding, the grinding procedure is carried out with the front end of the grinding wheel (Figure 13.2). During face grinding, the grinding wheel (designed as segmented grinding wheel or as a ring wheel) performs the cutting motion, whereas the workpiece carries out the lateral feed motion.

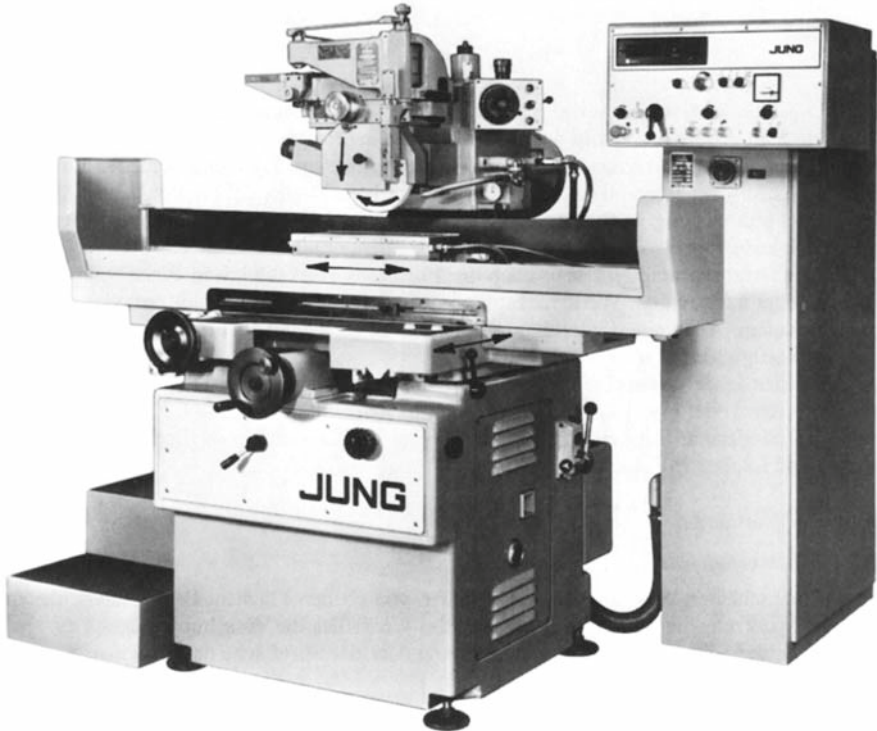


Figure 13.1
Face- and profile grinding machine
(photo by Jung GmbH, Göppingen)

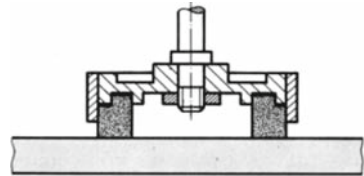


Figure 13.2
Face grinding principle with vertical wheel spindle

In contrast to circumferential grinding, the contact area between workpiece and tool is much greater in face grinding. Consequently, this method makes it possible to achieve higher metal removal rates. In face grinding, the tool axis may be vertical (Figure 13.2) or horizontal (in case of larger machines, see Figure 13.3).

Due to their compact design and great cutting capacity, machines with vertical wheel spindle axis are predominantly used for face grinding. Machines with hori-

zontal wheel spindle axis are used only if the surface pattern is decisive, usually just for appearance's sake, such as in profile grinding operations (Figure 13.3).

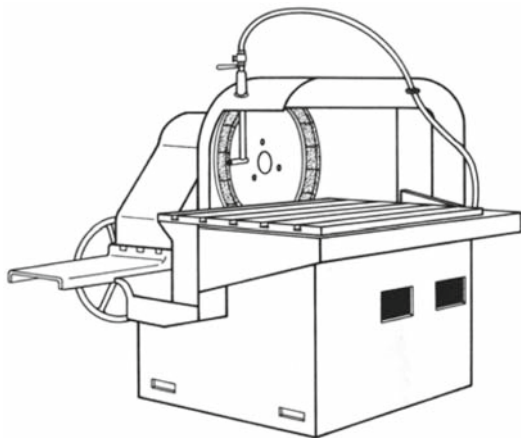


Figure 13.3
Segmented- surface grinding machine with horizontal wheel spindle axis

The face grinding procedures are distinguished according to the surface pattern generated (Figure 13.4): In cross grinding K, the grinding contours cross each other, whereas in arc grinding S, the grinding contours are allocated radially at one side. The mutually crossing grinding contours in cross grinding are generated if the wheel spindle axis is located normally to the workpiece. The radial allocation in arc grinding is created if the wheel spindle axis is inclined towards the workpiece.

For numerical infeed values, see Table 13.18.

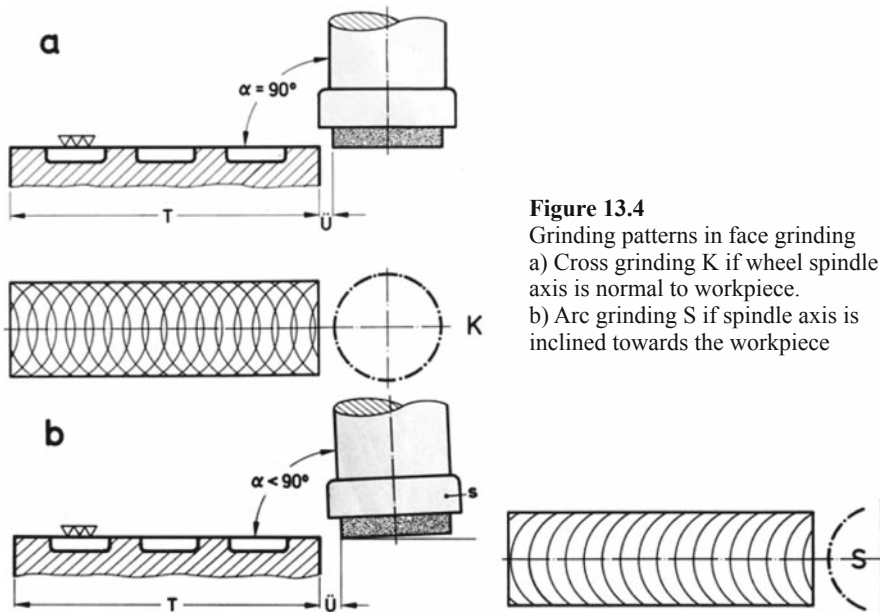


Figure 13.4
Grinding patterns in face grinding
a) Cross grinding K if wheel spindle axis is normal to workpiece.
b) Arc grinding S if spindle axis is inclined towards the workpiece

13.2.1.3 Profile grinding

Profile grinding is a circumferential grinding method carried out with profiled grinding wheels. In this procedure, as a rule, lateral feed is inapplicable. There are two common methods used to profile grinding wheels.

Simple profiles like radiuses, angles and grooves are generated with the common dressing attachments.

Complicated profiles are created with the so-called diaform attachment. This attachment is used to profile the grinding wheel along a template following the copying principle. Making use of CNC equipment, dressing and profiling are more and more being implemented by means of controlled motions.

13.2.2 Cylindrical grinding

Cylindrical grinding refers to the grinding of rotary parts.

In machining, a distinction is made between grinding from the outside (grinding the outer diameter of a shaft) and from the inside (grinding of a hole).

Another distinctive feature is the type of workpiece mounting, for example, whether the workpiece is held with or without a centre. Centreless grinding is explained in Chapter 13.2.4.

13.2.2.1 External cylindrical grinding

During external cylindrical grinding, the wheel performs both the cutting- and die infeed motion. The workpiece, which is fixed between centres or clamped in the chuck, is brought into rotation by a driving plate. Grinding wheel and workpiece have the same direction of rotation.

13.2.2.1.1 External cylindrical grinding with longitudinal feed

In grinding with longitudinal feed (Figure 13.5), as a rule, the table of the cylindrical grinding machine, and thus the workpiece, performs the longitudinal feed.

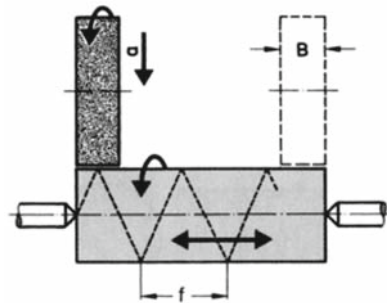


Figure 13.5
External cylindrical grinding with longitudinal feed – working principle

It is necessary to harmonize longitudinal feed and workpiece speed. If selecting longitudinal feed is set too high, the result is spiral-like markings on the workpiece.

A clean grinding pattern is obtained if feed s per workpiece rotation is less than grinding wheel width B . For numeral values for longitudinal feed, see Table 13.17.

Thin shafts may only be ground with small depths of cut due to the risk of deflection. For thick shafts, infeed is limited by the machine's input power. Too high depths of cut lead to greater contact areas between workpiece and wheel. Consequently, they result in increased cutting forces. For this reason, extreme infeed values may result in grinding wheel fracture.

To work with greater depths of cut, decrease longitudinal feed.

Depth of cut values are summarised in Table 13.18.

13.2.2.1.2 Plunge grinding

In plunge grinding (also plunge-cut grinding, see Figure 13.6), there is no longitudinal feed. The grinding wheel only performs the motion for depth setting. This method is needed, for example, to grind chamfers of shafts. For the infeed amount, the same criteria as for external cylindrical grinding with longitudinal feed are valid (see Table 13.18).

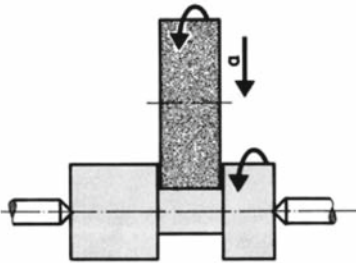


Figure 13.6
Plunge grinding – working principle

13.2.2.1.3 Thread grinding

Thread grinding is defined as cylindrical grinding with profiled grinding wheels. In this method as well, a distinction is made between longitudinal grinding (grinding with longitudinal feed of the workpiece) and plunge grinding.

During thread grinding with longitudinal feed, the thread can be generated with a “single-edged” wheel or a “multi-edged” wheel.

The narrow single-edged wheel, which has the profile of the thread to be generated (Figure 13.7), has a width of 6 to 8 mm.

The width of the multi-edged wheel is about 40 mm. This wheel is dressed conically. The threads (grooves) of the grinding wheel that first come into contact with the profile rough-grind it, while the two threads at the end (Figure 13.8) finish-grind it. This way, the entire chip removal is distributed over several grooves of the grinding wheel. This reduces the load per groove. For this reason, multi-edged wheels have a longer tool life than single-edged wheels.

Since the multi-edged wheel (Figure 13.8) is dressed conically, it is impossible to grind a thread directly on a shoulder with this wheel. As a result, this wheel can only be used for through threads.

Single-edged wheels are preferred to generate exact threads, since with these wheels one can achieve accuracy values of $\pm 2 \mu\text{m}$ for the effective diameter and ± 10 angular minutes for the thread angle.

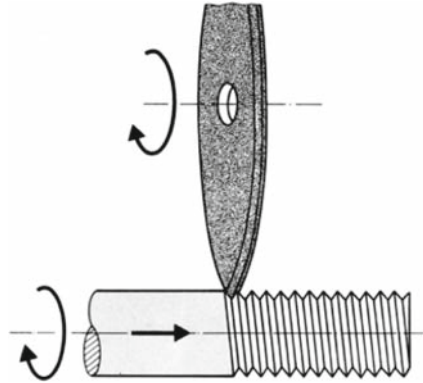


Figure 13.7
Longitudinal grinding of a thread with single-edged wheel

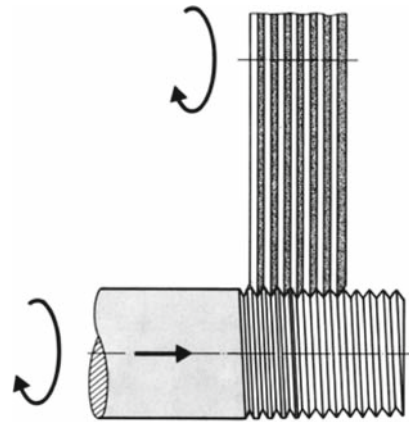


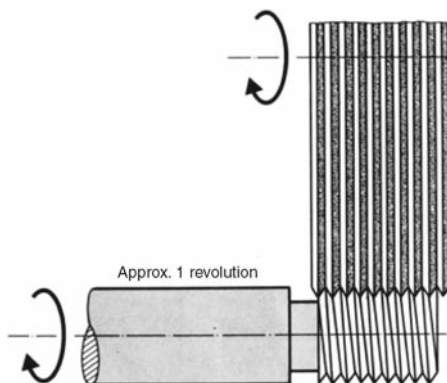
Figure 13.8
Longitudinal grinding of a thread with multi-edged wheel

During thread -plunge grinding (Figure 13.9), the thread is generated with a multi-edge grinding wheel. Here, the grinding wheel is dressed in parallel. During plunge grinding, as in the milling of short threads, the workpiece performs only $1\frac{1}{6}$ rotation. On each side, the grinding wheel should be about 2 mm wider than the thread to be generated.

For internal thread grinding, the same conditions as external thread grinding are valid; however, the grinding wheel diameters are correspondingly smaller in this case. Depending on workpiece size, they range from 20 to 150 mm.

During thread grinding, workpiece and grinding wheel have the same rotation direction. A motion for depth setting, which is executed by the grinding wheel, only exists in plunge grinding.

Figure 13.9
Plunge-thread grinding with multi-edged wheel



For thread grinding, the grinding result depends to a great extent on selecting an adequate wheel. The range of grain sizes (80 to 600) is the same for all leads, and the choice depends only on the minor thread radius.

The bonding of the grinding wheel to be chosen depends on the lead as well as the common selection criteria (compare 13.7.1.5).

13.2.2.2 Internal cylindrical grinding

Internal cylindrical grinding (Figure 13.10) corresponds to external cylindrical grinding in terms of its main criteria.

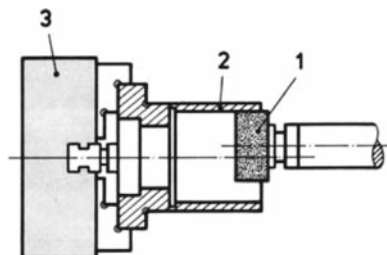


Figure 13.10
Internal cylindrical grinding –principle view
1 grinding wheel, 2 workpiece, 3 three-jaw chuck

The contact area between workpiece and wheel (Figure 13.11) is greater. The contact length l depends on depth of cut a and the diameter ratio between grinding wheel and workpiece.

Cutting motion, longitudinal feed and the motion for depth setting are carried out by the workpiece.

In internal grinding, the cutting speeds that are optimal for grinding can generally not be reached due to the small grinding wheel diameter.

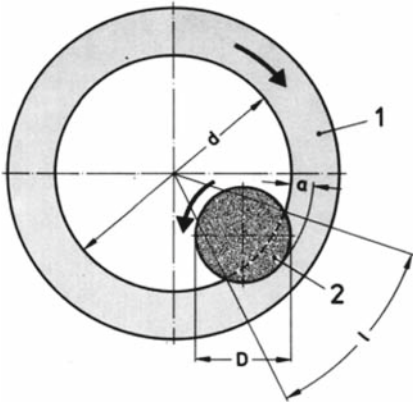
Optimal conditions are obtained when the following are selected

$$D \approx 0,8 d$$

D in mm wheel diameter

d in mm diameter of the workpiece hole

For feed- and infeed values, see Tables 13.18 and 13.19.

**Figure 13.11**

Contact length l of the grinding wheel in workpiece d workpiece diameter in mm, D grinding wheel diameter in mm

13.2.3 Cutting data for flat grinding and cylindrical grinding with clamped workpiece

The depth of cut a (infeed e of the grinding wheel) chosen depends on the wheel's grain size and the dimensions of the workpiece that is to be ground. Coarse-grained wheels allow greater depths of cut than fine-grained ones. Also, when fine-grained wheels are used, the pores clog more quickly. When this occurs, the wheel no longer cuts, but rather squeezes and lubricates. The general rule for common grinding is:

“Depth of cut must be less than the height of the abrasive grains protruding out of the bonding.”

In full-width grinding, this rule is broken. This is made possible by open-porous wheels of special design.

In finishing, the following must be observed:

1. The speed of the grinding wheel must be kept high and that of the workpiece low, if excellent surface quality is required;
2. Sparking emanating from the grinding wheel means that the wheel needs to be guided over the workpiece without infeed until no sparking no longer appears;
3. Reversal of the longitudinal feed must be adjusted so that the grinding wheel travel exceeds the workpiece only by one third of its width ($1/3 B$); otherwise the workpiece dimensions will be smaller than specified.

13.2.3.1 Grinding wheel speed, workpiece speed

Grinding wheel speed n arises from the permissible peripheral speed of the grinding wheel, which can be taken from reference tables (compare Tables 13.20, 13.21, 13.13).

$$n = \frac{v_c \cdot 60 \text{ s/min} \cdot 10^3 \text{ mm/m}}{D \cdot \pi}$$

n	in min^{-1}	wheel speed
v_c	in m/s	cutting speed of the grinding wheel = peripheral speed
D	in mm	grinding wheel diameter

Workpiece speed v_w is much lower than the wheel's peripheral speed. It is also drawn from reference tables. For cylindrical grinding, the workpiece speed is:

$$n_w = \frac{v_w \cdot 60 \text{ s/min} \cdot 10^3 \text{ mm/m}}{d \cdot \pi}$$

n_w	in min^{-1}	workpiece speed
v_w	in m/s	peripheral speed of the workpiece
d	in mm	workpiece diameter

Both speeds v and v_w should be in a predefined mutual speed ratio q .

$$q = \frac{v_c}{v_w}$$

q		speed ratio
v_c	in m/s	cutting speed of the grinding wheel (peripheral speed)
v_w	in m/s	peripheral speed of the workpiece

For the corresponding q values of different materials, see Table 13.0.

Table 13.0 Speed ratio q for different materials

Material	Q
Steel	125
Grey cast iron	100
Ms and Al	60

13.2.4 Centreless grinding

Centreless grinding is a grinding procedure in which the workpiece is located freely on a guide bar, in contrast to external- or internal cylindrical grinding in which the workpiece is between centres or clamped in a chuck (Figure 13.12).

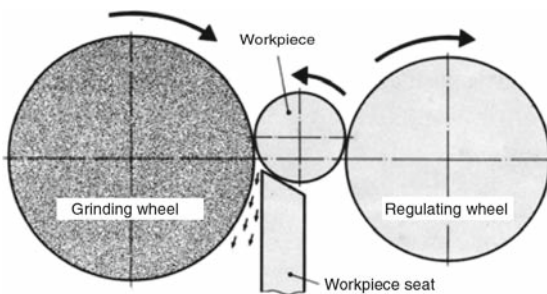


Figure 13.12
Centreless grinding principle

The workpiece rotation is generated through frictional resistance between the grinding- and regulating wheels. The axes of both wheels are located horizontally in one plane. The workpiece centre is situated above the connecting line of grinding- and regulating wheel centre.

The 3 major elements for centreless grinding are:

- grinding wheel
- regulating wheel
- workpiece seat

The workpiece seat is made of steel. It is hardened or equipped with a cemented carbide bar.

The resting angle β (Figure 13.13) is 30° on average. For workpieces with a large diameter, an angle of 20° is common practice.

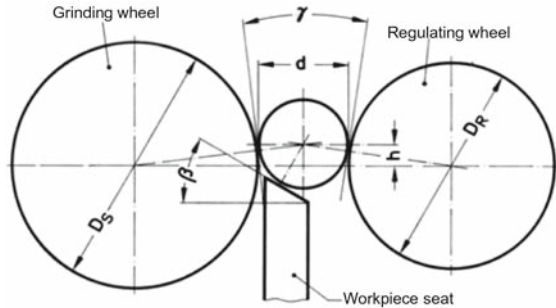


Figure 13.13
Height offset h , workpiece resting angle β and tangential angle γ during centreless grinding

Optimal height offset h can be calculated as an approximation according to Reeka (Figure 13.13) for a resting angle $\beta = 30^\circ$ and a tangential angle $\gamma = 12^\circ$ with the following equation.

$$h = 0,1 \cdot \frac{(D_R + d) \cdot (D_s + d)}{D_R + D_s + 2 \cdot d}$$

h	in mm	height offset
D_R	in mm	regulating wheel diameter
D_s	in mm	grinding wheel diameter
d	in mm	workpiece diameter

The size h can be calculated with the following rule of thumb as an approximation:

For workpieces up to 20 mm diameter:

$$h = \frac{d}{2}$$

h	in mm	height offset
d	in mm	workpiece diameter

For workpieces with a greater diameter (> 20 mm)

$$h = \sqrt{1,6 \cdot d}$$

More exact values related to the design of the grinding machine can be obtained from the grinding machine manufacturers.

The diameter ratio of regulating wheel to grinding wheel ranges from 0,6 to 0,8

$$D_R/D_s = 0,6 - 0,8$$

On average, the following equation is valid:

$$D_R = 0,7 \cdot D_s$$

D_R in mm regulating wheel diameter
 D_s in mm grinding wheel diameter

Workpiece seat and regulating wheel support the workpiece in the grinding region and bear the appearing grinding forces that are generated.

The regulating wheel consists of normal corundum grains and is rubber-bonded. In special cases, also rubber-bonded steel wheels or hardened steel wheels without rubber bonding are used.

The high friction coefficient of the regulating wheel material makes that the peripheral speeds of regulating wheel and workpiece are identical. The peripheral speed of the grinding wheel is much greater. As a result, a relative speed is generated between grinding wheel and workpiece, and this speed affects the material removal on the workpiece. Effective cutting speed on the workpiece results from the difference between the working speed of the grinding wheel and the peripheral speed of the regulating wheel.

The speed of the regulating wheel can be adjusted infinitely variably in a range from approximately 1 : 6 to 1 : 8.

Assuming an average value for the required workpiece-peripheral speed v_w ,

$$v_w = 0,3 \text{ m/s}$$

then speed and diameter of the regulating wheel can be calculated as follows:

$$n_w = \frac{v_w \cdot 60 \text{ s/min} \cdot 10^3 \text{ mm/m}}{d \cdot \pi} = \frac{0,3 \cdot 60 \cdot 10^3}{d \cdot \pi} = \frac{5730}{d}$$

$$D_R = 0,7 \cdot D_s$$

$$n_R = \frac{d \cdot n_w}{D_R} = \frac{5730}{D_R} = \frac{5730}{0,7 \cdot D_s} = \frac{8180}{D_s}$$

n_R in min^{-1} regulating wheel speed
 n_w in min^{-1} workpiece speed
 d in mm workpiece diameter
 D_s in mm grinding wheel diameter
 D_R in mm regulating wheel diameter
 v_w in m/s necessary peripheral workpiece speed
 8180 mm/min constant (rounded)

The adjustment of the wheel speed can be determined from peripheral wheel speed.

$$n_s = \frac{v_c \cdot 60 \text{ s/min} \cdot 10^3 \text{ mm/m}}{D_s \cdot \pi}$$

n_s in min^{-1} grinding wheel speed
 v_c in m/s cutting speed of the grinding wheel
 D_s in mm grinding wheel diameter
 $(v_c = 35 \text{ m/s for grinding of steel – see table with reference values 99})$

Even in centreless grinding, the speed ratio q should have the value given in Table 13.0.

$$q = \frac{v_c}{v_w}$$

q	speed ratio
v_c	in m/s cutting speed of the grinding wheel
v_w	in m/s peripheral workpiece speed

In centreless grinding, a distinction is made between two methods: Plunge grinding and through grinding.

13.2.4.1 Plunge grinding

In plunge grinding, grinding- and regulating wheels are inclined towards each other by $0,5^\circ$.

The slight axial thrust generated on the workpiece this way ensures that it rests on the top in an unambiguous position.

The plunge grinding procedure is as follows:

First, the workpiece is laid on the support rail with the regulating wheel retracted. Next, due to the motion for depth setting of the regulating wheel slide, the rotating regulating wheel is travelled in the direction of the grinding wheel (Figure 13.14), until the workpiece has been pressed against the grinding wheel.

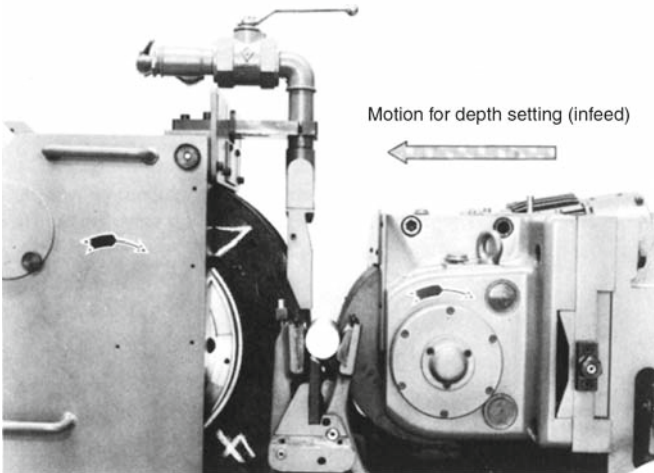


Figure 13.14

Centreless grinding with motion for depth setting (infeed)

(photo by DIAG, plant Fritz Werner, Berlin)

The grinding wheel grasps the workpiece and brings it into rotation. However, the speed of the workpiece is controlled by the regulating wheel, which acts as a frictional disk, and corresponds to the peripheral speed of the regulating wheel.

The grinding wheel, which rotates at a much higher peripheral speed (100-fold), makes a cut in the workpiece due to the speed difference between grinding- and regulating wheels.

At a given speed of the grinding wheel, the relative cutting speed and the number of grindings are set on the workpiece due to the regulating wheel speed.

13.2.4.2 Through grinding

During through grinding, the regulating wheel axis is inclined towards the grinding wheel axis in horizontal direction.

The range of the tilt angle α is given below:

$$\alpha = 2,5^\circ - 3^\circ$$

Thus, the workpiece has an axial thrust and moves in the axial direction. The passing speed v_A can be calculated as follows:

$$v_A = D_R \cdot \pi \cdot n_R \cdot \sin \alpha$$

D_R	in mm	regulating wheel diameter
n_R	in min^{-1}	regulating wheel speed
α	in $^\circ$	tilt angle of regulating wheel axis
v_A	in mm/min	passing speed of the workpiece

13.3 Application of grinding techniques

13.3.1 Flat grinding

Flat grinding is applied to generate plane-parallel and profiled surfaces. Typical parts with plane-parallel surfaces are die blocks for cutting dies, die shoes for press-and draw dies, clutch lamellae, rings of different design (Figure 13.15) and many other machine elements.

Grinding of external splines and punches with gear-tooth profiles (Figure 13.16), as well as grinding of profiled tools with complicated profiles from solids, are examples of uses of profile grinding (Figure 13.17).

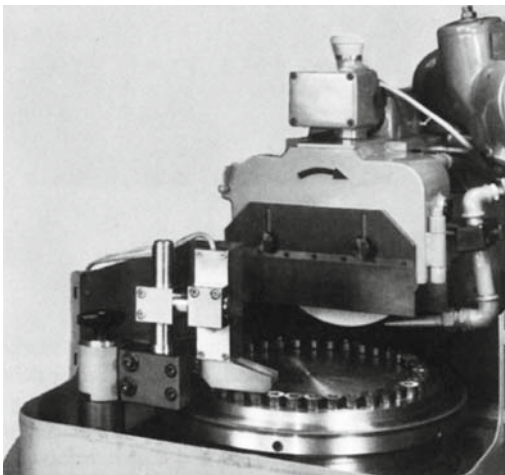


Figure 13.15

Flat grinding machine with rotary table Type HFR 30
(photo by Jung, Göppingen)

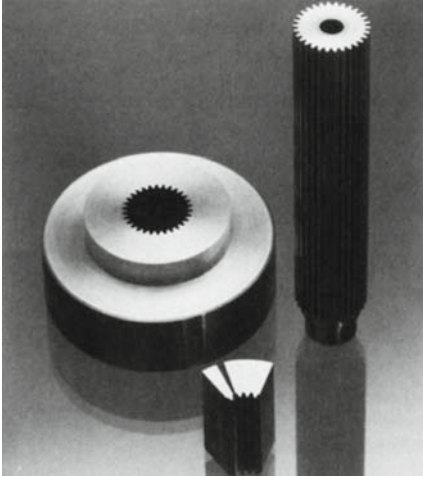


Figure 13.16
Grinding a profile into a complete cut for a toothed wheel
(photo by Jung, Göppingen)

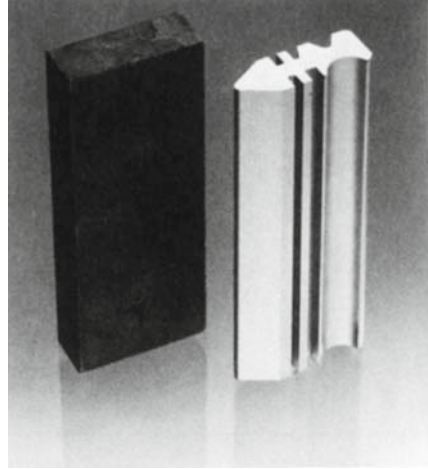


Figure 13.17
Grinding the profile into a punch, grinding from the solid
(photo by Jung, Göppingen)

13.3.2 Cylindrical grinding

Both external- and internal cylindrical grinding are used to machine rotary parts of any design (Figure 13.18).

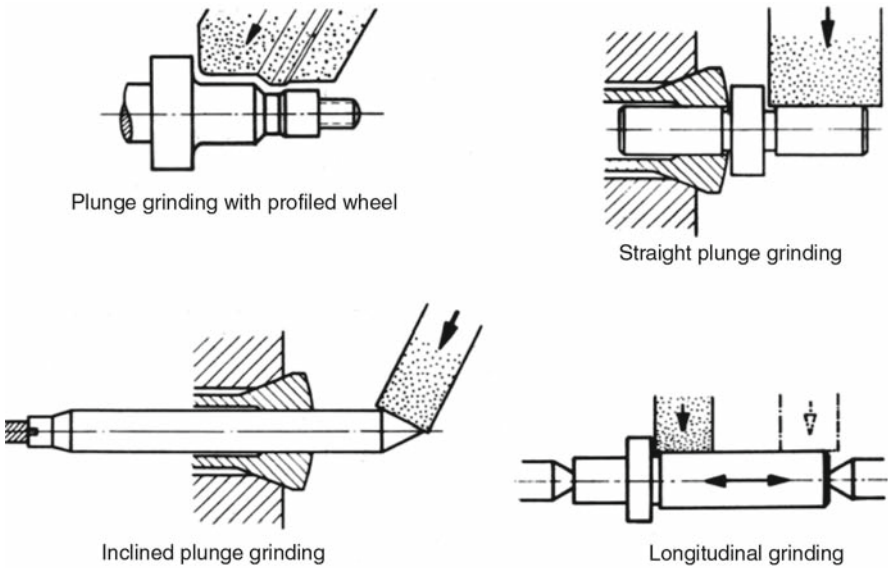


Figure 13.18
Examples of external cylindrical grinding

Special ranges of application for centreless grinding are:

Industry	Through grinding	Plunge grinding
Roll bearing industry	Ball bearing outer rings Rolling elements	–
Automotive industry	Brake pistons Shock absorber bars Bushings	Valves Valve lifters Camshafts (Figure 13.33) Crankshafts
Tool industry	Drills Pins (cylindrical)	Drills Taps Reamers Taper pins

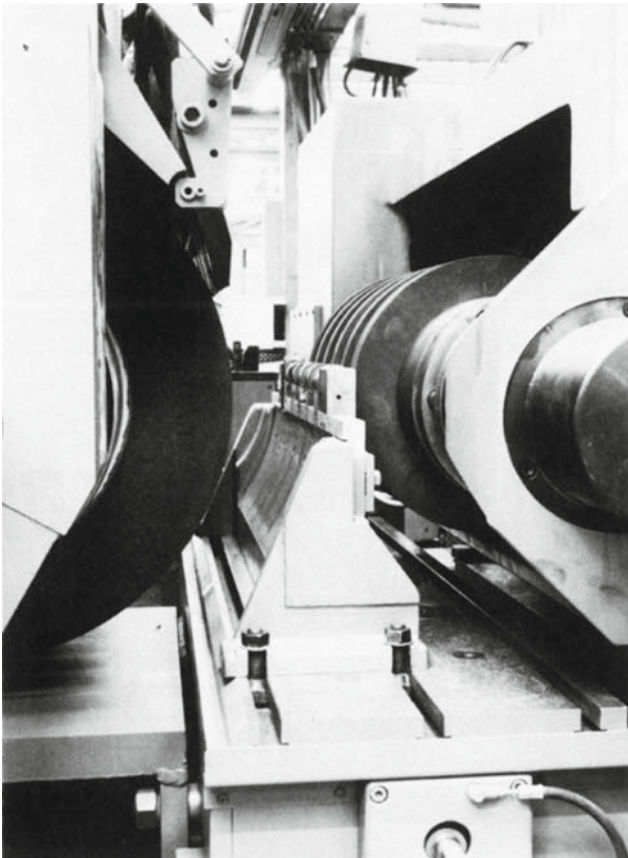


Figure 13.19
Grinding of a camshaft
(plunge grinding) on
a centreless grinding
machine with
roundtable, produced
by DIAG, plant Fritz
Werner, Berlin

13.4 Achievable accuracy values and allowances during grinding

Table 13.1 Allowances and achievable accuracy values

Grinding techniques	Allowance			Achievable accuracy	
	for one work piece length, in mm	Machining diameter or thickness of the work-piece, in mm	Allowance related to diameter, in mm	Accuracy to size	Peak-to-valley height R_p , in μm
Flat-	up to 100	up to 50	0,2–0,25	IT 8–IT 9 (IT 5–IT 6)	3–8 (1–3)
	150–200	up to 150	0,3–0,35		
Profile-	20–100	–	Partially ground from the solid	IT 4–IT 5	2–4
External cylindrical-	up to 150	up to 50	0,2–0,25	IT 6 IT 8	5–10
	200–400	100–150	0,25–0,30		
Internal cylindrical-	up to 50	up to 20	0,1–0,15	IT 8 IT 10	10–20
	80–100	21–100	0,2–0,25		
Centreless-	up to 100	up to 300	0,2–0,3	IT 4 IT 6	2–4
		31–100	0,2–0,3		

As a general rule: The greater the machining diameter or the machining thickness and the longer the workpiece, the higher the allowance.

The allowances are valid for unhardened workpieces. For hardened workpieces, increase the values from the tables by 20–40%.

13.5 Calculation of force and power

Since the cutting edges are geometrically ambiguously defined, it is impossible to perform an exact calculation of the major cutting force and the machine input power.

Research work by Salje aimed at finding the average thickness of cut and the number of cutting edges in contact should provide a more exact power calculation.

Preger's paradigm attempts to deduce the cutting force calculation from milling to grinding.

According to Preger, it is possible to calculate mean thickness of cut from infeed e , grinding wheel diameter and feed per grinding cutting edge f_z .

For flat grinding, it follows

$$h_m = f_z \cdot \sqrt{\frac{a_c}{D_s}}$$

h_m	in mm	mean thickness of cut
f_z	in mm	feed per grinding cutting edge
D_s	in mm	grinding wheel diameter

Feed f_z per grinding cutting edge can be calculated from the effective grain distance λ_{ke} (distance between 2 abrasive grains really acting) and the ratio q .

$$f_z = \frac{\lambda_{ke}}{q}; \quad q = \frac{v_c}{v_w}$$

λ_{ke} in mm effective grain distance
 q speed ratio
 v_c in m/s cutting speed of the grinding wheel
 v_w in m/s peripheral speed of the workpiece

For calculation of force and the necessary machine input power, the following equations can be derived:

1. Mean thickness of cut

1.1. Flat grinding

$$h_m = \frac{\lambda_{ke}}{q} \sqrt{\frac{a_e}{D_s}}$$

1.2. Cylindrical grinding

$$h_m = \frac{\lambda_{ke}}{q} \sqrt{e \cdot \left(\frac{1}{D_s} \pm \frac{1}{d} \right)}$$

+ for external cylindrical grinding
 – for internal cylindrical grinding

h_m in mm mean thickness of cut
 λ_{ke} in mm effective grain distance
 q speed ratio
 a_e in mm infeed during grinding (cutting contact)
 D_s in mm grinding wheel diameter
 d in mm workpiece diameter

Table 13.2 Effective grain distance λ_{ke} in mm, as a function of infeed e in mm and grain size of the grinding wheel

a_e in mm ↓ Grain size →	Finishing				Roughing		
	0,003	0,004	0,005	0,006	0,01	0,02	0,03
60	39	38	37	36	33	23	15
80	47	46	45	44	40	31	24
100	54	53	52	51	48	38	30
120	60	59	58	57	53	44	37
150	64	63	62	61	56	48	40

2. Specific cutting force k_c

$$k_c = \frac{(1 \text{ mm})^2}{h_m^2} \cdot k_{c1,1} \cdot K$$

- k_s in N/mm² specific cutting force
- $k_{s1,1}$ in N/mm² specific cutting force for $h_m = b = 1$ mm
- K correction factor considering grain size influence (Table 13.3).

3. Mean major cutting force F_{cm} per cutting edge

$$F_{cm} = b \cdot h_m \cdot k_c$$

- F_{cm} in N mean major cutting force per cutting edge
- b in mm width of cut = effective grinding width
- h_m in mm mean thickness of cut
- k_c in N/mm² specific cutting force

Table 13.3 Correction factor K as a function of grain size and mean thickness of cut

↓ Grain size ↘ h_m in mm →	0,001	0,002	0,003	0,004
40	5,1	4,3	4,0	3,6
60	4,5	3,9	3,5	3,2
80	4,0	3,6	3,2	3,0
120	3,4	3,0	2,8	2,5
180	3,0	2,6	2,4	2,2
280	2,5	2,2	2,0	1,9

4. Angle of approach φ

4.1 Flat grinding

4.1.1. Circumferential grinding (Figure 13.20)

$$\cos \varphi = 1 - \frac{2a_c}{D_s}$$

- φ angle of approach
- a_c in mm infeed (grinding contact)
- a_p in mm width of cut

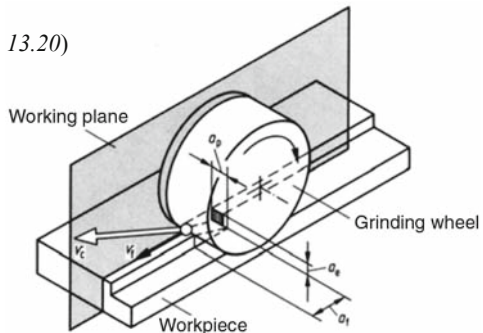


Figure 13.20

a_f in mm feed contact
 D_s in mm grinding wheel diameter

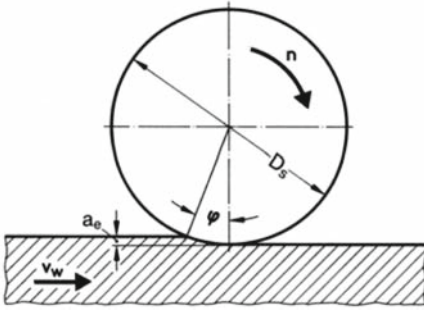


Figure 13.20a
 Angle of approach during circumferential grinding

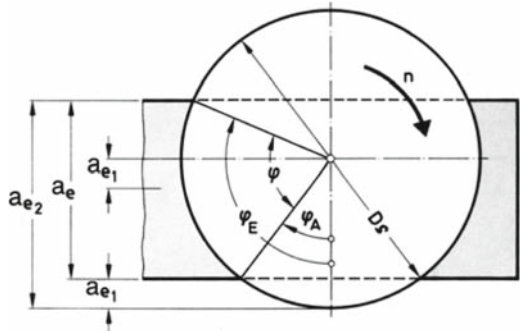
4.1.2 Face grinding (Figure 13.21)

$$\varphi = \varphi_E - \varphi_A$$

φ angle of approach
 φ_E final angle
 φ_A initial angle

$$\cos \varphi_A = 1 - \frac{2a_{e1}}{D_s}$$

$$\cos \varphi_E = 1 - \frac{2a_{e2}}{D_s}$$



a_e in mm width of cut

Figure 13.21
 Angle of approach during face grinding

a_{e1} } in mm components of the width of cut according to Figure 13.21
 a_{e2} }

D_s in mm grinding wheel diameter

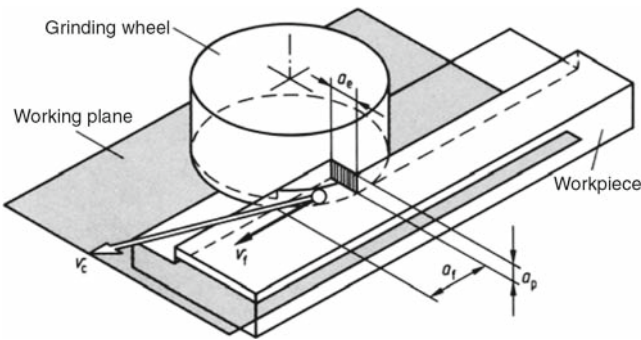


Figure 13.22
 Depth of cut a_p , grinding contact a_c and feed contact a_f during side grinding (draft for DIN 6580 page 9)

4.2. Cylindrical grinding

$$\varphi \approx \frac{360^\circ}{\pi} \cdot \frac{a_e}{\sqrt{D_s \cdot \left(1 \pm \frac{D_s}{d}\right)}}$$

+ for external cylindrical grinding
– for internal cylindrical grinding

φ	in °	angle of approach
a_e	in mm	infeed
D_s	in mm	grinding wheel diameter
d	in mm	workpiece diameter

The approximation formula is valid for $\varphi \leq 60^\circ$

5. Number of cutting edges in contact

This quantity can be determined according to an approach by Preger:

$$z_E = \frac{D_s \cdot \pi \cdot \varphi}{\lambda_{Kc} \cdot 360^\circ}$$

z_E		number of cutting edges in contact
D_s	in mm	grinding wheel diameter
λ_{Kc}	in mm	effective grain distance
φ	in °	angle of approach

6. Mean total major cutting force F_m

$$F_m = F_{cm} \cdot z_E$$

F_m	in N	mean total major cutting force
F_{cm}	in N	mean major cutting force per cutting edge
z_E		number of cutting edges in contact

7. Machine input power

$$P = \frac{F_m \cdot v_s}{10^3 \text{ W/kW} \cdot \eta_M}$$

P	in kW	machine input power during grinding
v_s	in m/s	peripheral speed of the grinding wheel
η_M		machine efficiency ($\eta_M = 0,5$ to $0,7$)

13.6 Calculation of the machining time

13.6.1 Flat grinding

13.6.1.1 Circumferential grinding

$$t_h = \frac{B_b \cdot i}{f \cdot n}$$

t_h	in min	machining time
B_b	in mm	grinding wheel path in cross direction
i		number of grounds with sparking out
f	in mm/DH	feed per double stroke (DH)
n	in DH/min	number of double strokes (DH) per minute

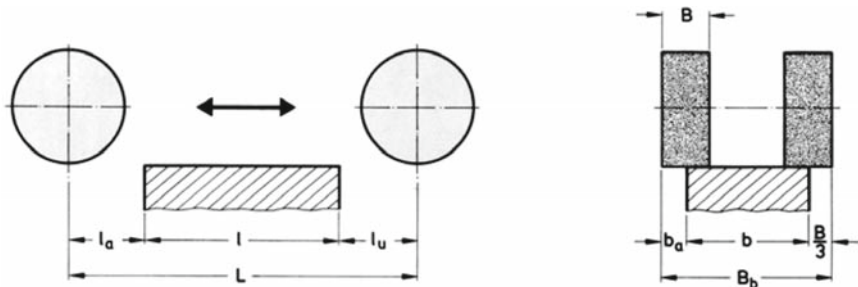


Figure 13.23
Flat grinding principle – circumferential grinding

$$B_b = \frac{2}{3} \cdot B + b \quad b_a = \frac{1}{3} \cdot B$$

b	in mm	workpiece width
B	in mm	grinding wheel width
b_a	in mm	grinding wheel overrun

$$L = l_a + l + l_u$$

L	in mm	grinding wheel path in longitudinal direction
l_a	in mm	approach
l_u	in mm	overrun
l	in mm	workpiece length

$$l_a = l_u = 10 \text{ bis } 40 \text{ mm}$$

$$l_a \approx 0,04 \cdot l$$

$$n = \frac{v_w}{2 \cdot L}$$

n	in DH/min	number of double strokes (DH) per minute
v_w	in mm/min	workpiece speed
L	in mm	grinding wheel path in longitudinal direction

$$i = \frac{z_h}{a_c} + 8$$

i		number of grindings
z_h	in mm	allowance
a_c	in mm	infeed per double stroke (cutting contact)
8		number of double strokes for sparking out

13.6.1.2 Face grinding

In circumferential grinding (face grinding), as a rule, grinding wheel diameter D_s (Figure 13.24) is equal to or slightly greater than the workpiece width. Consequently, there is no path in cross direction in this method. This has the following effect on the machining time:

$$t_h = \frac{i}{n}$$

i number of grindings
 n in DH/min number of double strokes (DH) per minute

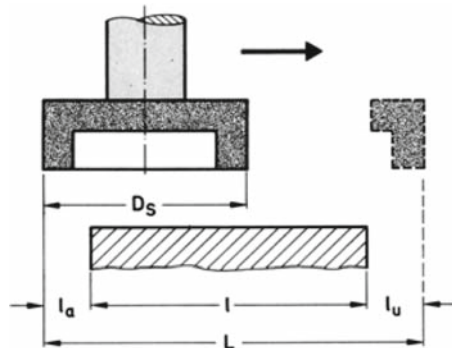


Figure 13.24
 Flat grinding principle – face grinding

13.6.2 External- and internal cylindrical grinding

13.6.2.1 Longitudinal feed

For this method, the same conditions as in turning are given.

$$t_h = \frac{L \cdot i}{f \cdot n_w}$$

$$L = l - \frac{1}{3}B$$

t_h in min machining time
 i number of grindings
 f in mm feed per workpiece rotation
 n_w in min^{-1} workpiece speed
 L in mm grinding wheel path in longitudinal direction
 l in mm workpiece length
 B in mm grinding wheel width

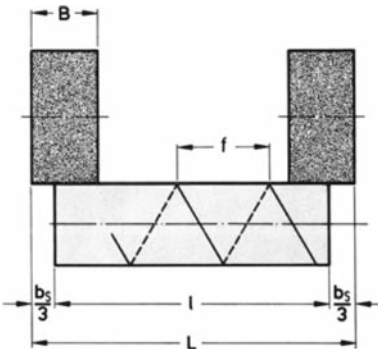


Figure 13.25
 External grinding with longitudinal feed

The number of grindings i results from the diameter difference of the workpiece measured before and after the grinding procedure.

$$i = \frac{\Delta d}{2 \cdot a_e} + 8$$

8		number of double strokes for sparking out	
Δd	in mm	diameter difference	
a_e	in mm	infeed per ground	
d_v	in mm	diameter before grinding	} On workpiece
d_n	in mm	diameter after grinding	

$$\Delta d = |d_v - d_n|$$

For Δd , the absolute value is valid, without considering the sign, which becomes negative during internal grinding.

13.6.2.2 Plunge grinding

$$t_h = \frac{L}{v_f} = \frac{\Delta d}{2 \cdot a_e \cdot n_w}$$

t_h	in min	machining time
a_e	in mm	infeed per workpiece rotation (cutting contact)
n_w	in min^{-1}	workpiece speed
Δd	in mm	diameter difference
v_f	in mm/min	feed rate

13.6.3 Centreless grinding

13.6.3.1 Through grinding

$$t_h = \frac{L \cdot i}{v_A}$$

v_A	in mm/min	workpiece passing speed
n_R	in min^{-1}	regulating wheel speed
α	in $^\circ$	tilt angle ($\alpha = 2,5^\circ - 3^\circ$)
i		number of grindings

$$L = l + B$$

L	in mm	workpiece path
l	in mm	workpiece length
B	in mm	grinding wheel width
b_R	in mm	regulating wheel width

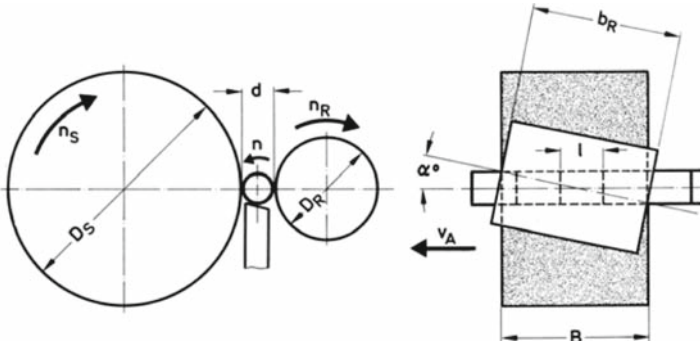


Figure 13.26
Centreless through grinding - principle

When grinding many workpieces without clearance in the through grinding mode, such as rollers for roller bearing, then the following is valid

$$L = n \cdot l + B$$

n number of rollers ground without clearance

13.6.3.2 Plunge grinding

$$t_h = \frac{L}{v_f} = \frac{\Delta d}{2 \cdot a_e \cdot n_w}$$

13.7 Grinding wheels

13.7.1 Tool materials

13.7.1.1 Abrasives

The most essential abrasives are corundum, silicon carbide, boron carbide, boron nitride and diamond.

The types of corundum, whose main component is aluminium oxide, are subdivided into natural corundum and electrocorundum.

Electrocorundum is derived from bauxite by means of electrochemical melting. The solidified fusion is reduced in size and milled to wheel size. Hardness and brittleness of the corundum abrasive grain increase as a function of increased crystalline Al_2O_3 content.

Consequently, three qualities are distinguished:

normal corundum NL:	95%	Al_2O_3
semi-precious corundum HK:	98%	Al_2O_3
precious corundum EK:	99,9%	Al_2O_3

The corundum types are classified in DIN 69100.

Silicon carbide (SiC) is also made in an electrochemical procedure, from petroleum coke, which is rich in carbon, and silica sand. Silicon carbide is one of the hardest artificial abrasives; it is harder than electrocorundum.

Boron nitride is a boron nitrogen bond. It is known as “Borazone”, a name copyrighted by the manufacturer (General Electric Company).

Diamond is the hardest abrasive.

Today, given the synthetic manufacturing technologies available, artificial diamonds can be produced in predefined grain size according to the requirements for different purposes.

Allocation of hardness according to the hardness scale by Knoop is elucidated in Table 13.4.

Table 13.4 Hardness of abrasives

Material	Hardness in kN/mm ²
Corundum	20
Silicon carbide	28
Boron nitride	48
Diamond	70

Table 13.5 The most essential abrasives - properties and ranges of applications

Abrasive	Properties	Common ranges of application
Normal corundum NK	Very hard and tough	Low alloyed steel, cast steel, malleable cast iron, heavy rough grinding with high metal removal rate
Semi-precious corundum HK	High hardness, but less tough than normal corundum	Hardened steel, heat-treated steel
Precious corundum EK	White precious corundum, very hard, brittle and easy-to-cut abrasive grain pink precious corundum, very hard, slightly less brittle than 81A dark-red special corundum, tougher for its hardness than 81A and 82A monocrystal corundum, very hard, wear-resistant abrasive grain	Hardened, alloyed steel, tool- and high speed steel, stainless steel unhardened, alloyed steel with high strength, hardened steel highly alloyed tool steel highly alloyed, heat-sensitive tool- and high-speed steel
Silicon carbide SC	Green silicon carbide, extremely hard and brittle, shock-sensitive dark silicon carbide, extremely hard, slightly less brittle than 1C	White cast iron, cemented carbide, non-ferrous metals, hard, non-metallic materials Grey cast iron, metallic and non-metallic materials with low tensile strength
Diamond DT	Very hard	Lapping and grinding of carbide-tipped tools, simultaneous grinding of cemented carbide and steel

13.7.1.2 Grain sizes

The abrasive grain sizes are marked by numbers according to DIN 69100. The higher the code number, the finer the grain size. The ident number is also the sieve number. It specifies the number of meshes per inch over the length of the sieve.

Table 13.6 Grain sizes according to DIN 69100 (grain sizes in mm)

Very coarse		Coarse		Medium	
No.	Grain size	No.	Grain size	No.	Grain size
8	2,830–2,380	14	1,680–1,410	30	0,710–0,590
10	2,380–2,000	16	1,410–1,190	36	0,590–0,500
12	2,000–1,680	20	1,190–1,000	46	0,420–0,350
		24	0,840–0,710	50	0,350–0,297
				60	0,297–0,250

Fine		Very fine		Dust-fine	
No.	Grain size	No.	Grain size	No.	Grain size
70	0,250–0,210	150	0,105–0,088	280	0,040–0,030
80	0,210–0,177	180	0,088–0,074	320	0,030–0,020
90	0,177–0,149	200	0,074–0,062	400	0,020–0,016
100	0,149–0,125	220	0,062–0,053	500	0,016–0,013
120	0,125–0,105	240	0,053–0,040	600	0,013–0,010
				800	0,007–0,003

The grain sizes printed in **bold** letters are most commonly used.

13.7.1.3 Hardness grades

For a grinding wheel, hardness is understood as the resistance to grain-break off from the bond. It is not identical with the hardness of an abrasive grain. The bonding hardness should be adjusted so that the abrasive grains break off when they become dull. This way, the grinding wheel regulates its own sharpness (self-dressing). The hardness grades are defined in letters

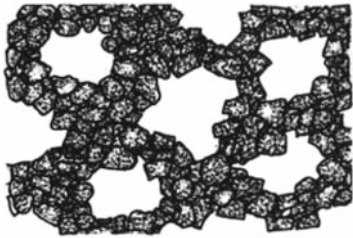
Table 13.7 Hardness grades of the grinding wheels according to DIN 69100

Very soft	Soft	Medium	Hard	Very hard	Extremely hard
E F G	H I Jot K	L M N O	P Q R S	T U V W	X Y Z

The hardness grades printed in bold letters are most commonly used.

13.7.1.4 Grinding wheel structure

The grinding wheel structure (Figure 13.27) is similar to a honeycomb. It is defined by the spatial ratios for the abrasive grain, the binder and the pores. The maximum ratio is covered by the pores. The international structure denomination is given in Table 13.8.



very open

Figure 13.27
Structure of a highly porous grinding wheel

Table 13.8 Marking of grinding wheel structures

Very dense	Dense	Medium	Open-porous	Very open-porous
1, 2	3, 4	5, 6, 7, 8	9, 10, 11	12, 13, 14

The structures printed in **bold** letters are most commonly used.

13.7.1.5 Bond types

The abrasive grains are mixed with binders and pressed or cast into the desired shape. Afterwards, they are baked depending on the binder at 1200 to 1400 °C (for example, ceramic binders), or dried at 300 °C (for example, silicate bonds). The most frequently used bonds according to DIN 69100 are given in Table 13.9:

Table 13.9 Bond types

	Name of the binder	Main components	Advantages	Disadvantages
Rigid, inelastic bonds (mineral bonds)	Ceramic – Ke	Clay with additives	Unaffected by water, oil, heat very handy	Limited strength, long manufacturing time
	Magnesite – Mg	Sorel – cement	Dense structure provides a smooth ground	Low strength, for this reason v_{zul} low
	Silicate – Si	Soluble glass	Not baked, but dried at 300 °C, and thus quickly produced, water-proof	
Elastic bonds (organic bonds)	Artificial resin – Ba	Bakelite Phenol resins (80%) and Cresole (10%) or formaldehyde (10%)	Handy, easily cut, higher strength than ceramic bond, allowing high cutting speed, short manufacturing time	Dry storage required, limited operating time
	Rubber–Gu	India rubber with filling materials	Dense structure, high strength, particularly suitable for grinding wheels of less thickness and wheels with sharp profile	Temperature-sensitive, softening at 120°C
	Natural resin – Nh	Shellac		

13.7.2 Design types and denomination of grinding wheels

13.7.2.1 Design types

Some frequently used shapes and the associated standards according to which the dimensions of these grinding wheels are defined are shown in Figure 13.28.

Due to the large number of standards existing for grinding wheels, only selected examples are given on this and the following pages. A complete summary is given in the bibliography.




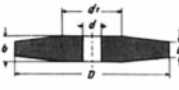
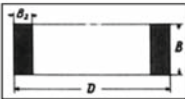
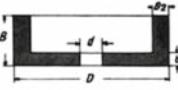
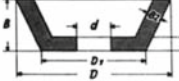




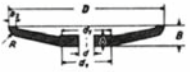
<p>Straight wheel DIN 69120</p> 	<p>One-sided recessed straight wheel DIN 69123</p> 	<p>Straight wheel recessed on both sides DIN 69123</p> 
<p>Conical wheel DIN 69123</p> 	<p>Grinding cylinder DIN 69138</p> 	<p>Cup wheel Form D DIN 69149</p> 
<p>Conical cup wheel DIN 69149</p> 	<p>Dish wheel Form A DIN 69149</p> 	<p>Dish wheel Form B DIN 69149</p> 
<p>Double-sided conical grinding wheel, Form C DIN 69149</p> 	<p>Conical cup wheel Form E DIN 69149</p> 	<p>Dish wheel Form BH DIN 69149</p> 

Figure 13.28
Widely used wheel shapes

Figure 13.29 shows the possible wheel profiles. An overview of the dimensions of the grinding wheels for tool grinding according to DIN 69149 includes Table 13.10.

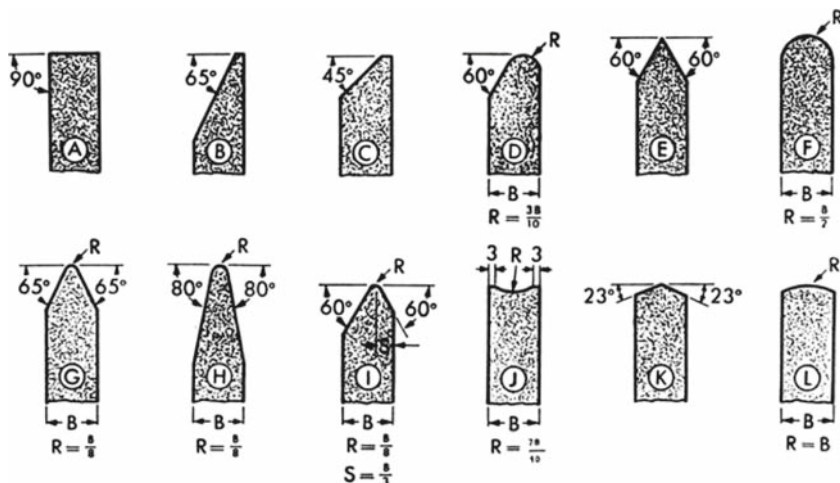


Figure 13.29
Grinding wheel profiles

Table 13.10 Ranges of dimensions for grinding wheels according to DIN 69149 (denominations see Figure 13.28)

Wheel type	Main sizes of the grinding wheel, in mm		
	D	B	d
Cup wheel Form D	50–150	32–80	13–20
Conical cup wheel	50–150	25–50	13–20
Dish wheel Form A and B	80–250	8–21	20–32
Wheel, conical on both sides Form C	80–250	8–19	20–32
Conical cup wheel Form E	50–150	25–50	13–20
Dish wheel Form BH	200	25	32

The dimensions of the residual forms are defined in the following standards.

- DIN 69120 Straight wheel from 4 to 900 mm external diameter
- DIN 69125 Straight wheel, recessed, for internal grinding
- DIN 69138 Grinding cylinder with floor flange for flat grinding
- DIN 69139 Straight cup wheels for flat grinding of 40–200 mm \varnothing
- DIN 69159 Cutting-off wheel

In addition to these types, the wheel manufacturers produce grinding wheels in all dimensions up to 1200 mm \varnothing for special ranges of application and grinding machine types.

13.7.2.2 Denomination of grinding wheels according to DIN 69100

Wheel dimension $D \times B \times d$	Wheel according to DIN	Abrasive	Hardness	Structure	Bond
$175 \times 32 \times 51$	DIN 69120	EK	M	5	Ke

The grinding wheel demonstrated in this example is a grinding wheel according to DIN 69120 (Figure 13.30) with the following parameters:

- External diameter: $D = 175$ mm
- Width: $B = 32$ mm
- Hole diameter: $d = 51$ mm
- Abrasive: precious corundum (EK)
- Hardness: M
- Structure: 5
- Ceramic bond: Ke

Figure 13.30
Straight wheel according to DIN 69120

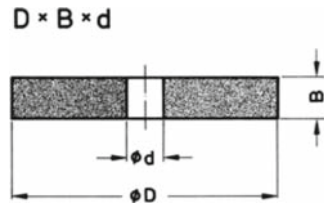


Table 13.11 Wheel parameter according to DIN 69100

Abrasive	Grain size	Hardness	Structure	Bond
Normal corundum NK	8	D	2	Ceramic Ke
	10	E	3	
	12	F	4	
	14	G	5	
Semi-precious corundum HK	16	H	6	Synthetic resin Ba
	20	I	7	
	24	J	8	
	30	K	9	
Precious corundum EK	36	L	10	Rubber Gu
	46	M	11	
	54	N	12	
	60	O	13	
Corundum (black) KS	70	P	14	Silicate Si
	80	Qu	15	
	90	R	16	
	100	S	1	
Natural corundum KO	120	T	2	Magnesite Mg
	150	U	3	
	180	V	4	
	220	W	5	
Silicon carbide SC	140	X	6	Natural resin Nh
	280	Y	7	
	400	Z	8	
	500		9	
Diamond DT	600		10	

Each grinding wheel has to be fitted with a label, which includes the characteristics of the bonded abrasive and the name of the manufacturer (Figure 13.31). The abrasive is specified by the label's ground colour.

Table 13.12 Label colours and associated abrasives

Label colour	Abrasive
Brown	Normal corundum (NK)
Yellow	Semi-precious corundum (HK)
Red	Precious corundum (EK)
Green	Silicon carbide (SC)

In addition to this colour, the label also has a coloured diagonal stripe. The colour of this stripe specifies the maximally permissible peripheral speed of the wheel.



Figure 13.31
Grinding wheel label

Table 13.13 Colour of the diagonal stripes on the label assigned to permissible peripheral wheel speed

Diagonal stripe colour	Maximally permissible peripheral wheel speed, in m/s
White	15–25
Blue	45
Yellow	60
Red	80
Green	100

13.7.3 Wheel mounting

Since grinding wheels work at high peripheral speeds, severe accidents may result if a wheel bursts.

For this reason, wheels have to be checked for soundness before assembly. When the wheel is struck lightly, the resulting sound will be impure if the wheel is cracked or damaged. Wheels that make this sound must not be used!

When clamping into the flanges (Figure 13.32), pay attention to the following:

1. Put elastic interpass materials (rubber, soft paperboard, felt or leather) between flanges and grinding wheel.
2. The flanges should have rotation grooves from 0,5 to 1,0 mm depth.
3. Flange diameter should be minimally $\frac{1}{3}$ of the grinding wheel diameter.
4. The flanges should cover at least $\frac{1}{6}$ of the wheel sidewise height.

In case of large grinding wheels up to 1000 mm diameter and 40 mm thickness without any recess, the conditions shown in Figure 13.32a are valid.

If it is impossible to use protective hoods, then conical wheels (Figure 13.32b) with a sidewise inclination 1 : 16 are preferable.

Clamp large wheels with a large hole between flanges (Figure 13.32c) set up for balancing.

Abrasive cups (Figure 13.32d) are fixed with a counter flange that receives the sidewise pressure.

Ring wheels (Figure 13.32e) are luted on a supporting plate with dove-tail groove.

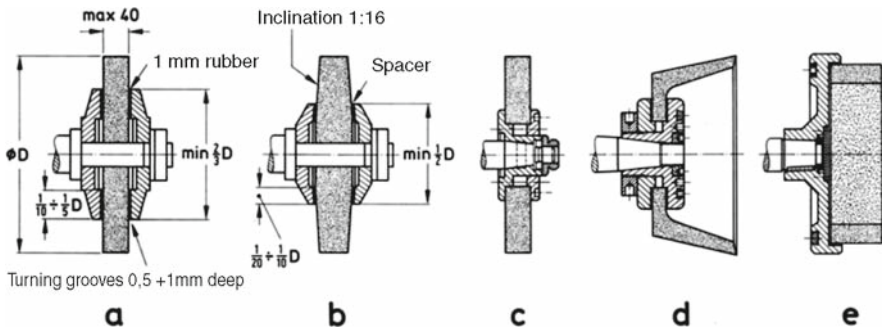


Figure 13.32
Wheel mounting

a straight-, *b* conical wheels, *c* with large hole, *d* grinding cups (cup wheels), *e* ring wheels

13.7.4 Grinding wheel selection for special ranges of application

Table 13.14 Guidelines for the selection of abrasive, grain size, hardness and structure for ceramically bonded grinding wheels (excerpt from DIN 69102 and documents by the firm Elbe-Schleifmittelwerk)

Material	Cylindrical grinding				Flat grinding			
	External grinding		Internal grinding		Peripheral cut up to 200 mm wheel diameter	Face grinding		
	between centres	centreless	grinding wheel diameter in mm	up to 16		16–36	36–80	Cup wheel 200–350 Ø
Case-hardening- and tool steels Alloyed steels hardened up to 63 HRC	EK 50 L 6	HK 60 L 5	EK 80 L 5	EK 60 K 5	EK 46 Jot 6	EK 46 Jot 6	EK 30 Jot 10	EK 30 Jot 10
High-speed steels hardened up to 63 HRC	EK 50 Jot 6	EK 50 K 5	EK 80 Jot 6	EK 60 I 6	EK 46 H 9	EK 46 G 11	EK 36 G 10	EK 30 I 10
High-speed steels hardened > 63 HRC	EK SC 50 I 6	EK 60 L 5	SC 80 I 6	SC 60 H 6	SC 46 G 9	EK 46 G 11	EK 36 G 10	EK 30 H 10
Cemented carbide	SC 60 H	SC 60 I	SC 80 M	SC 60 L	SC 46 K	SC 60 G	SC 50 G	SC 50 H
Steel, unhardened up to 700 N/mm ²	NK 50 M 6	NK 60 M 5	HK 80 M 6	HK 60 L 6	HK 46 K 6	EK 46 K 10	EK 36 K 10	EK 24 K 10
Heat-treated steel up to 1200 N/mm ²	NK 50 L 6	HK 60 M 5	EK 60 L 6	EK 60 K 6	EK 46 Jot 6	EK 46 I 14	EK 36 I 10	EK 24 Jot 10
Grey cast iron	SC EK 50 Jot 6	SC 50 K 5	SC 80 K 6	SC 60 Jot 6	SC 46 I 8	EK 46 I 12	EK 36 I 10	EK 30 Jot 8
Zinc alloys and light metals	SC 46 I 3 ¹⁾	SC 60 K 9	SC 60 I 8	SC 60 19	SC 46 Jot 10	SC 36 I 12 ¹⁾	SC 24 I 10 ¹⁾	SC 20 I 10 ¹⁾

1) Bond from artificial resin This table includes:
 abrasive – grain size – hardness – structure
 for example EK 50 L 6

13.8 Failures during grinding

13.8.1 Parameters influencing the grinding procedure

An optimal grinding result may only be expected if the grinding tool and the – conditions (peripheral speed, feed values, infeed) are correctly aligned for the workpiece.

The following Table 13.15 shows the extent to which an alteration of the individual factors affects the grinding result.

Table 13.15 Parameters influencing grinding and their effects on the grinding result

Alteration		Effects on the grinding result
Grinding wheel		
Grain size	Coarser	Higher metal removal rate. Peak-to-valley height on workpiece increases.
	Finer	Lower metal removal rate. Peak-to-valley height on workpiece decreases. Wheel appears harder and has higher form stability.
Hardness	Harder	Metal removal rate decreases. Dull grains break off later or not at all. Increased heating of the workpiece (grinding cracks, structural change).
	Softer	Abrasive grains break off earlier. Wheel wear increases. Peak-to-valley height on workpiece increased. Defects of form increase.
Structure	Denser	Wheel is harder. Wheel has higher form stability. Decreased peak-to-valley height on workpiece.
	More open	Wheel is softer. Wheel grinds at lower temperature. Increased peak-to-valley height on workpiece.

Wheel peripheral speed

Higher	Wheel is harder. Decreased peak-to-valley height on workpiece.
Lower	Wheel is softer.

Workpiece speed

Higher	Wheel is softer.
Alteration	Effect on grinding result

Workpiece form

Small contact zone between wheel and workpiece (for example external cylindrical grinding)	Harder wheel required so that abrasive grain does not break off too early.
Large contact zone between wheel and workpiece (for example, in flat grinding with cup wheel)	Use softer or more open-porous wheel to get close to the range of self-sharpening and to limit heating
Interruptions in the workpiece surface	Wheel is softer.

(excerpt from the records of the Elbe-Schleifmittelwerke)

13.8.2 Table of failures

Table 13.16 Failures during grinding

Effects on the workpiece	Failure reason	Remedy
Grinding cracks Scorch marks soft zones or distortion on the workpiece	Wheel too hard infeed too high cutting speed too high insufficient cooling	Softer grinding wheel lower infeed diminish v better cooling
Feed markings (in cylindrical grinding helix lines on surface)	Wheel too hard Wheel incorrectly dressed, one-sided wheel contact	Redress Use softer grinding wheel
Chatter marks	Vibrations Wheel too hard or incorrectly balanced workpiece incorrectly mounted	Softer grinding wheel rebalance check workpiece mounting
Particles coming off wheel	Grains come off the wheel and get into the coolant cycle	Improve coolant cleaning Check grinding wheel
Grinding grooves	Wheel too rough Sparking out time too short	Use smaller grain size longer sparking out

13.9 Reference tables

Table 13.1 Accuracy values and allowances during grinding
(see Chapter 13.4 page 245).

Table 13.14 Abrasive, grain size, hardness and structure of the grinding wheels
(see Chapter 13.7.4, page 263)

Table 13.17 Feed values during grinding

Kind of machining	Cylindrical grinding with longitudinal feed	Flat grinding (peripheral grinding)
	Feed in longitudinal direction	Lateral feed
	f in mm/revolution	f in mm/stroke
Roughing	$\frac{2}{3} \cdot B$ bis $\frac{3}{4} \cdot B$	$\frac{2}{3} \cdot B$ bis $\frac{4}{5} \cdot B$
Finishing	$\frac{1}{4} \cdot B$ bis $\frac{1}{2} \cdot B$	$\frac{1}{2} \cdot B$ bis $\frac{2}{3} \cdot B$
Precision machining	–	2,0 mm

B in mm grinding wheel width

Table 13.18 Infeed e in mm (depth of cut a_c) during grinding

Kind of machining	Material	Cylindrical grinding			Flat grinding
		External	Internal	Recessing	
Roughing	Steel	0,02–0,04	0,01–0,03	0,002–0,02	0,03–0,1
	Grey cast iron (GG)	0,04–0,08	0,02–0,06	0,006–0,03	0,06–0,2
Finishing	Steel	0,002–0,01	0,002–0,005	0,0004–0,005	0,002–0,01
	Grey cast iron (GG)	0,004–0,02	0,004–0,01	0,001–0,006	0,004–0,02

Table 13.19 Cutting speeds of grinding wheel v_c in m/s, workpiece speeds v_w in m/s and speed ratios $q = v_c/v_w$ for circular- and flat grinding. Excerpt from the firm document by Naxos-Union, Frankfurt, and DIN 69103.

Material	Cylindrical grinding										Flat grinding				Parting off (grinding)					
	External cylindrical grinding					Internal cylindrical grinding					Circumferential grinding					Face grinding				
	Pre-		Finish-			v_c	v_w	q	v_c	v_w	q	v_c	v_w	q		v_c	v_w	q		
	v_c	v_w	q	v_c	v_w														q	v_c
Steel, soft	30	0,22	130	30	0,17	180	25	0,32	80						0,1 up to 0,42	250 up to 60				
Steel, hardened	35	0,27	130	35	0,17	210	25	0,38	65			30	0,16 up to 0,58	180 up to 50				45 up to 80		
Grey cast iron	25	0,22	115	25	0,18	135	25	0,38	65							0,1 to 0,5	250 to 50			
Brass and bronze	30	0,32	95	30	0,27	110	25	0,40	60			25	0,25 to 0,67	40 to 100		0,33 to 0,75	60 to 27			
Al-alloys	20	0,58	35	20	0,45	45	20	0,58	35			20								–
Cemented carbide	8	0,08	100	8	0,07	120	8	0,13	60			8	0,07	115	25	0,07	115			45

With special permission of the DSA (German committee for grinding wheels), it is possible to exceed the peripheral speeds of the grinding wheels v_c in the case of special wheels (see also Table 13.20)

Table 13.20 Increased peripheral speeds for grinding wheels by Naxos-Union, Frankfurt (excerpt from records of Naxos-Union) permitted by the DSA

DSA permission number	Denomination	Bond	Lowest hardness	Coarsest grain size	Da maximal diameter.	B max. thickness	Max. hole	Min. wall thickness.	Minim. Floor thickness	Operating speed w m/s
952	grinding wheels highly compressed without hole	Ba	Z	10	610	76	–	–	–	80
966	grinding wheels highly compressed with fine grain centre	Ba	Z	10/12	610	76	305	–	–	80
969	grinding wheels with fine grain centre	Ba	L	12	610	76	0,5 Da	–	–	60
969	grinding wheels with fine grain centre	Ba	L	12	800	100	0,5 Da	–	–	60
1079	grinding wheels	Gu	O P	60 46	500 760	50 30	0,5 Da	–	–	60
1097	grinding wheels even on wet ground	Ba	L	24cb	610 1000	510 250	} 0,5 Da	–	–	60
1207	Minimal abrasive material (minimal wheel)	Ke	I	24 {	50 45 40 35	30 35 45 50	} 0,18 Da	–	–	45
1208	Cutting-off wheels with fibre reinforcem.	Ba	–	24	230	1/50 Da	22,3	–	–	80
1211	Cutting-off wheels with fibre reinforcem.	Ba	–	16	800	1/50 Da	0,1 Da	–	–	100
1297	Minimal wheel	Ba	N	20	50	25	Shank 10 mm	–	3/5 B	45
1300	Separating disks reinf. by fibrous mat., for hand-cutting-off machines	Ba	N	24	300	1/50 Da	0,14 Da	–	–	80
1310	Grindg. wheels re-inforc. by fibrous mat.	Ba	–	10/16	500	65	DIN 69120	–	–	80
1414	Cup wheels with fine grain floor and reinforcement	Ba	O	10/27	400	260	0,25 Da	0,25 Da	0,19 B	45
1705	Separating disks reinforced by fibrous material	Ba	R	20	1200	1/50 Da	0,6 Da max 250	–	–	80
1706	Separating disks hot pressed reinf. by fibrous material	Ba	Z	14	1200	14	0,25 Da	–	–	100
1744	Grinding wheels hole, tintured with artificial resin	Ke	L	100	610	50	0,5 Da	–	–	80
1767	Separating disks rein-forced by fibrous mat.	Ba	–	24	1200	1/50 Da	0,2 Da	–	–	100
1827	Grinding wheels with recess	Ke	H	46	300	50	127	60	20	45

Other abrasive manufacturers have similar permissions similar to those shown above.

Table 13.22 Permissible imbalances of grinding wheels (in g) as a function of wheel weight (in kg), diameter (in mm) and peripheral speed (in m/s)

Wheel weight, in kg	Grinding wheel diameter, in mm								
	to 305			305–610			Greater than 610		
	Peripheral speed, in m/s								
	up to 40	40–63	63–100	Up to 40	40–63	61–100	Up to 40	40–63	63–100
0,5	5,6	4,5	3,6	7,2	5,6	4,5	8,9	7,2	5,6
1,0	7,9	6,4	5,1	10	8,0	6,3	13	10	8
2,0	11	9	7	14	11	9	18	14	11
3,0	13	11	9	18	13	11	22	18	13
4,0	16	13	10	20	16	13	25	20	16
6,0	19	16	12	25	19	16	31	25	19
10	25	20	16	32	25	20	40	32	25
15	31	25	20	39	31	25	49	39	31
20	35	28	23	45	35	28	57	45	35

Example: Assuming a grinding wheel of 500 mm diameter, 6 kg weight, to be run at a peripheral speed of 60 m/s, an imbalance of 19 g is permissible.

Table 13.23 Weight of some straight wheels, in kg, according to DIN 69120

Wheel diameter, in mm	Wheel width, in mm						
	6	10	16	25	40	63	100
25	0,008	0,013	0,020	0,033	0,052	–	–
50	0,030	0,050	0,075	0,125	0,200	–	–
100	0,12	0,20	0,32	0,50	0,80	–	–
150	0,26	0,45	0,72	1,13	1,80	–	–
200	0,48	0,80	1,28	2,00	3,20	–	–
300	1,1	1,8	2,9	4,5	7,2	–	–
400	–	3,2	5,1	8,0	13	20	32
500	–	–	–	13	20	32	50
650	–	–	–	–	33	52	83
750	–	–	–	–	–	69	110
900	–	–	–	–	–	102	162

Table 13.24 Metalworking fluids (cooling and lubrication) for grinding

Medium	Additional agents	Suitable for	
		Kind of process	Material
Water	–	Simple machining	Non-ferrous metals
Watery solutions	Soda or abrasive powders (salt) (3–5%)	Simple machining with low requirements in terms of surface quality	Steel Grey cast iron
Emulsions (mix of H ₂ O and drilling oil, share of drilling oil 2%)	Emulsifiers that keep the oil distributed in water	Flat-, cylindrical- and profile grinding operations	For all metals
Grinding oils (mineral oils with viscosities 16–36 cSt at 50 °C) not suitable for wheel with natural resin or rubber bond	Extreme pressure additives (for example sulphur, chlorine- or phosphor compounds) corrosion inhibitors	External- and internal cylindrical grinding under hard machining conditions, grinding of gears, threads and grooves grinding with v_s 60 m/s	Steel, hardened stainless steels highly alloyed steels light metals Magnesium
Spindle oil	Petroleum (mixture 1 : 1)	Honing	Steel, copper aluminium magnesium
Petroleum	–	For fine grinding and honing	Steel and copper alloys

13.10 Calculation examples

Example 1

Case hardened shafts (60 $\varnothing \times 140$ long), made of 16 MnCr 5 (Figure 13.33), with a grinding allowance of 0,2 mm, have to be ground to final size.

Sought for:

1. Feasible grinding techniques
2. Choice of grinding technique
3. Choice of wheel
4. Definition of cutting parameters
5. Determine machine input power ($\eta_M = 0,6$)
6. Calculate machining time

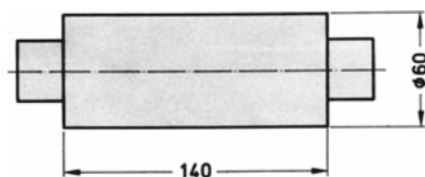


Figure 13.33
Shaft to be ground

Approach:

1. Cylindrical grinding with longitudinal feed or cylindrical grinding – plunge grinding
2. For shaft manufacturing, cylindrical grinding with longitudinal feed is chosen
3. Choice of wheel
- 3.1. Abrasive, grain size, hardness and structure
a grinding wheel of the quality EK 50 L 6 was chosen from Table 13.14
- 3.2. Wheel dimension
400 \varnothing \times 40 mm width was chosen from Table 13.23
4. The following values were chosen from the Tables 13.17, 13.18 and 13.19:
 $v_c = 35\text{m/s}$; $v_w = 0,27\text{m/s}$; $q = 130$; $a_e = 0,003\text{ mm}$
Feed in longitudinal direction: $f = 0,7 \cdot B = 0,7 \cdot 40\text{ mm} = 28\text{ mm/U}$
5. Machine input power
- 5.1. Mean thickness of cut

$$h_m = \frac{\lambda_{Kc}}{q} \cdot \sqrt{a_e \cdot \left(\frac{1}{D_s} + \frac{1}{d} \right)} = \frac{39\text{ mm}}{130} \cdot \sqrt{0,003\text{ mm} \left(\frac{1}{400\text{ mm}} + \frac{1}{60\text{ mm}} \right)}$$

$$h_m = \frac{39\text{ mm}}{130} \cdot 0,0076 = 0,0023\text{ mm}$$

($\lambda_{Kc} = 39$ from Table 13.2)

- 5.2. Specific cutting force

$$k_c = \frac{(1\text{ mm})^2}{h_m^2} \cdot k_{c1,1} \cdot K = \frac{(1\text{ mm})^{0,26}}{0,0023^{0,26}} \cdot 2100\text{ N/mm}^2 \cdot 4 = 40800\text{ N/mm}^2$$

$K = 4,0$ interpolated from Table 13.3

- 5.3. Mean major cutting force per cutting edge

$$F_{cm} = b \cdot h_m \cdot k_c$$

Effective grinding width b corresponds to about 0,7fold of the grinding wheel width B and was consequently assumed as $b = 28\text{ mm}$.

$$F_{cm} = 28\text{ mm} \cdot 0,0023\text{ mm} \cdot 40800\text{ N/mm}^2 = 2627,5\text{ N}$$

- 5.4. Angle of approach φ

$$\varphi = \frac{360^\circ}{\pi} \cdot \sqrt{\frac{a_e}{D_s \cdot \left(1 + \frac{D_s}{d} \right)}} = \frac{360^\circ}{\pi} \cdot \sqrt{\frac{0,003\text{ mm}}{400\text{ mm} \left(1 + \frac{400\text{ mm}}{60\text{ mm}} \right)}} = 0,11^\circ$$

- 5.5. Number of cutting edges in contact z_E

$$z_E = \frac{D_s \cdot \pi \cdot \varphi^\circ}{\lambda_{Kc} \cdot 360^\circ} = \frac{400\text{ mm} \cdot \pi \cdot 0,11^\circ}{39\text{ mm} \cdot 360^\circ} = 0,0098$$

- 5.6. Machine input power

$$P = \frac{F_{cm} \cdot z_E \cdot v_s}{10^3\text{ W/kW} \cdot \eta_M} = \frac{2627,5\text{ N} \cdot 0,0098 \cdot 35\text{ m/s}}{10^3\text{ W/kW} \cdot 0,6} = 1,5\text{ kW}$$

6. *Machining time*

- 6.1. Number of cuts i_{ges}

$$i = \frac{\Delta d}{2a_e} + 8 = \frac{(60,2 \text{ mm} - 60 \text{ mm})}{2 \cdot 0,003 \text{ mm}} + 8$$

$$i = 41$$

6.2. Wheel path in longitudinal direction

$$L = l - \frac{1}{3}B = 140 \text{ mm} - \frac{40 \text{ mm}}{3} = 126,7 \text{ mm}$$

6.3. Feed per revolution (Table 13.17)

$$f = 0,7 \cdot B = 0,7 \cdot 40 \text{ mm} = 28 \text{ mm/revolution} \quad \text{revolution: U}$$

6.4. Workpiece speed (see Chapter 13.2.3.1.)

$$n_w = \frac{v_w \cdot 60 \text{ s/min}}{d \cdot \pi} = \frac{0,27 \text{ m/s} \cdot 60 \text{ s/min}}{0,06 \text{ mm} \cdot \pi} = 86 \text{ min}^{-1}$$

$$n_w = 90 \text{ min}^{-1} \text{ selected from Figure 7.47, page 81, standard speed}$$

6.5. Machining time

$$t_h = \frac{L \cdot i}{f \cdot n_w} = \frac{126,7 \text{ mm} \cdot 41}{28 \text{ mm/U} \cdot 90 \text{ U/min}} = 2,06 \text{ min}$$

The product $f \cdot n_w$ results in the feed rate v_f of the grinding machine table.

$$v_f = f \cdot n_w = 28 \text{ mm/U} \cdot 90 \text{ U/min} = 2520 \text{ mm/min}$$

If the grinding machine is driven hydraulically, then one can in effect infinitely adjust each calculated table speed in the regulating range of the machine.

For mechanical drives, there are only special fixed feed rates.

In this case, select the feed rate next to the calculated value v_f , and insert it into the equation for the machining time.

v_{flat} in mm/min Feed rate of the table actually available or adjustable on the machine.

Example 2

The task is to grind a plate made of E 360, 400 mm length \times 200 mm width \times 30 mm thickness, on one surface.

The 2nd surface has already been ground. Allowance is 0,8 mm.

Sought for:

1. Grinding technique
2. Choice of grinding wheel
3. Choice of cutting parameters
4. Machining time

Approach:

1. The applied grinding technique is flat grinding (face- or circumferential grinding). Here, the chosen technique is circumferential grinding.
2. Choice of grinding wheel
 - 2.1. Abrasive, grain size, hardness and structure from Table 13.14: EK 46 K 14
 - 2.2. Wheel dimensions
 - 200 \varnothing \times 25 mm width, selected from Table 13.23.

3. Choice of cutting parameters

3.1. Peripheral speeds from Table 13.19

$$v_c = 30 \text{ m/s}; v_w = 0,3 \text{ m/s} = 18 \text{ m/min}; q = \frac{v_c}{v_w} = \frac{30}{0,3} = 100$$

3.2. Lateral feed (Table 13.17)

$$f = 0,7 \cdot B = 0,7 \cdot 25 \text{ mm} = 17,5 \text{ mm/stroke}$$

$$f = 35 \text{ mm/double stroke}$$

3.3. Infeed e from Table 13.18

$$a_e = 0,06 \text{ mm selected for calculation, on average}$$

For the first strokes, $e = 0,1 \text{ mm}$ is chosen, and for a residual allowance of approx. $0,1 \text{ mm}$,

$$a_e = 0,03 \text{ mm is selected.}$$

4. Machining time (Chapter 13.6.1.)

4.1. Wheel path in cross direction

$$B_b = \frac{2}{3} \cdot B + b = \frac{2}{3} \cdot 25 \text{ mm} + 200 \text{ mm} = 216,7 \text{ mm}$$

4.2. Wheel path in longitudinal direction

$$L = l_a + l + l_u$$

$$l_a = l_u = 0,04 \cdot l = 0,04 \cdot 400 \text{ mm} = 16 \text{ mm}$$

$$L = 16 \text{ mm} + 400 \text{ mm} + 16 \text{ mm} = 432 \text{ mm}$$

4.3. Number of grindings (number of infeeds)

$$i = \frac{z_h}{a_e} + 8 = \frac{0,8 \text{ mm}}{0,06 \text{ mm}} + 8 = 13,3 + 8 = 21,3 \rightarrow 21$$

4.4. Number of double strokes per minute n

$$n = \frac{v_w}{2 \cdot L} = \frac{18 \text{ m/min}}{2 \cdot 0,432 \text{ m}} = 20,8 \text{ DH/min}$$

4.5. Machining time

$$t_h = \frac{B_b \cdot i}{f \cdot n} = \frac{216,7 \text{ mm} \cdot 21}{35 \text{ mm/DH} \cdot 20,8 \text{ DH/min}} = 6,25 \text{ min}$$

Example 3

The task is to grind 1000 rollers for ball bearings, made of alloyed steel, with 64 HRC hardness and the dimension

$$20 \text{ mm } \varnothing \times 30 \text{ mm length.}$$

Allowance is $0,1 \text{ mm}$.

A grinding wheel with

$$D_s = 300 \text{ mm } \varnothing \text{ and a width of } B = 150 \text{ mm}$$

is used.

Sought for:

1. Manufacturing process
2. Regulating wheel diameter
3. Height offset of the support ruler

4. Machining time

Approach

1. *Centreless through grinding* is selected as the operational principle.

2. Regulating wheel diameter

$$D_R = 0,7 \cdot D_s = 0,7 \cdot 300 \text{ mm} = 210 \text{ mm}$$

3. Height offset

$$h = 0,1 \cdot \frac{(D_R + d) \cdot (D_s + d)}{D_R + D_s + 2 \cdot d} = \frac{0,1 \cdot (210 \text{ mm} + 20 \text{ mm}) \cdot (300 \text{ mm} + 20 \text{ mm})}{210 \text{ mm} + 300 \text{ mm} + 2 \cdot 20 \text{ mm}}$$

$$h = \frac{0,1 \cdot 230 \text{ mm} \cdot 320 \text{ mm}}{550 \text{ mm}} = 13,38 \text{ mm}$$

According to the rule of thumb:

$$h = \frac{d}{2} = \frac{20 \text{ mm}}{2} = 10 \text{ mm}$$

4. Machining time

4.1. Path of 1000 workpieces

$$L = n \cdot l + B = 1000 \cdot 30 \text{ mm} + 150 \text{ mm} = 30150 \text{ mm}$$

4.2. Number of grindings (Chapter 13.6.2.1.)

$$i = \frac{\Delta d}{2 \cdot a_e} = \frac{0,1 \text{ mm}}{2 \cdot 0,01 \text{ mm}} = 5$$

($a_e = 0,01 \text{ mm}$ selected)

4.3. Regulating wheel speed (Chapter 13.2.4.)

$$n_R = \frac{8,18}{D_s} = \frac{8,18 \text{ m/min}}{0,3 \text{ m}} = 27,26 \text{ min}^{-1}$$

4.4. Passing speed

(Inclination of regulating wheel assumed with $\alpha = 3^\circ$)

$$v_A = D_R \cdot \pi \cdot n_R \cdot \sin \alpha = 210 \text{ mm} \cdot \pi \cdot 27,26 \text{ min}^{-1} \cdot 0,0523 = 941,2 \text{ mm/min}$$

4.5. Machining time

$$t_h = \frac{L \cdot i}{v_A} = \frac{30150 \text{ mm} \cdot 5}{941,2 \text{ mm/min}} = 160,2 \text{ min}$$

14 Abrasive cutting

Abrasive cutting is a grinding procedure which is exclusively intended for parting off material, as in sawing.

This method is applied to part off solid material, profiles and tubes.

For cutting-off wheels, corundum or silicon carbide is used as the tool material. Artificial resin or rubber is the binder for the cutting-off wheels.

Material loss due to cutting off is kept low, since the cutting-off width B (B approximately 1% of the wheel diameter) is low.

During abrasive cutting, the cutting speed ranges from 45 to 80 m/s.

Maximal cutting-off diameter d_{\max} should not exceed $1/10$ of the grinding wheel diameter.

$$d_{\max} = 1/10 D$$

d_{\max} in mm maximally feasible cutting-off diameter

D in mm grinding wheel diameter

The cutting-off wheel diameters range from 100 to 500 mm, and wheel thickness values from 2 to 5 mm.

15 Abrasive belt grinding

During abrasive belt grinding, an endless grinding belt runs on 2 or more rollers (Figure 15.1). The roller, for which the method is named and on which contact between grinding belt and workpiece occurs, is referred to as the contact wheel.

The metal removal rate, the surface quality of the workpiece and the tool life of the grinding belt depend primarily on the contact wheel's design.

Contact wheels (Figure 15.2) consist of an aluminium or plastic core that is coated with rubber, plastics or textile material.

Figure 15.1

Abrasive belt grinding machine-working principle

- a) stationary abrasive belt grinder (grinding wheel spindle head)
 1 guide roll,
 2 grinding belt,
 3 contact wheel
- b) Universal stator grinding machine with 2 guide rolls and 1 contact wheel

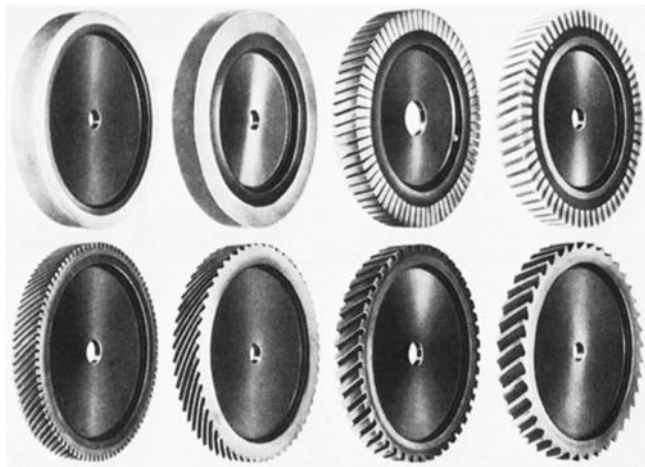
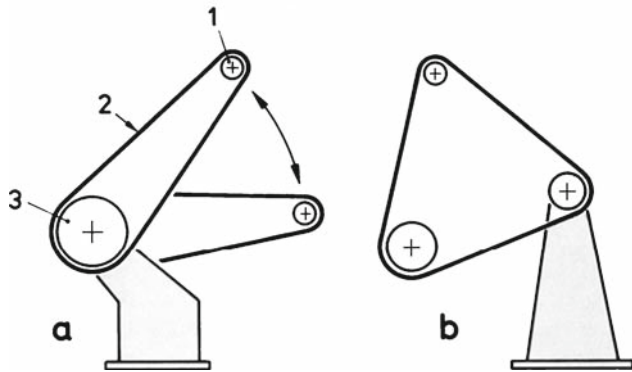


Figure 15.2

Contact wheel design types

The wheel's contact area may be smooth or helical/ double-helical with various angles. The lands are rectangular or saw-like, depending on each range of application. The hardness values of the support pads range from 40 to 95 shores on the shore-A scale.

Hard contact wheels with saw profiles are required to achieve high metal removal rates. Rectangular grooved contact wheels of medium hardness are used for common grinding operations, whereas smooth and soft contact wheels are applied for finishing grinding.

Hardness is the parameter that most affects the grinding result. Metal removal rate increases as a function of increased hardness; however, peak-to-valley height increases, too.

Smaller land widths and greater groove widths, as well as a smaller contact wheel diameter, also result in an increase in the amount of metal removed per unit of time, as well as in a coarser grinding pattern.

The grinding belts have a length of 2 to 5 m. Due to the length, the belt grains can cool down on the return stroke.

The belt grains are uniformly distributed in their bonding material with the tips upward. The gaps between grains are not filled with binder as they are in the case of felt wheels used for polishing.

Since the belt grains are positioned homogeneously and are not surrounded with binder, the grinding capacity is greater than it is for grinding with coated (emery) wheels.

Skin glues, synthetic resins and varnishes are used as binders.

For cooling and lubrication, in contact grinding, spray oils are used (with 5° E or 37° cSt at 20 °C) for manually guided workpieces, flood oils (with 1,6°–4° E) for broad belt equipment and grinding operations that generate a great deal of heat.

Emulsions of water-soluble mineral oils are used for throughfeed grinding, whereas greases are used for grinding of finished formed or cast workpieces, which only need to be polish ground for follow-up electroplating or varnishing.

15.1 Application of the abrasive belt grinding method

Today, abrasive belt grinding, which was originally almost exclusively used for abrasive belt polishing instead of the grinding-wheel spindle head, to which it was considered preferable, embraces almost all grinding techniques. Abrasive belt grinding is often used as a grinding method for finishing, since it is able to generate outstanding surface qualities.

All fundamental grinding techniques, such as flat- and cylindrical grinding, are also implemented as abrasive belt grinding methods.

Since the contact wheels rotate exactly and, unlike the grinding wheel, do not wear out, it is possible with abrasive belt grinding to achieve a constant cutting speed, which is a prerequisite for automated grinding.

Abrasive belt grinding is preferentially applied in grinding of

- Ironwork for construction and furniture,
- Parts for bicycles and hand tools,

Parts from the flatware industry,
 Base plates for irons,
 Rotational solids and plane-parallel plates for various industries.

On flat grinding machines (Figure 15.3), for example, metal- and plastic parts are face ground. But centreless circular grinding (Figure 15.4) can also be performed using the abrasive belt grinding method.

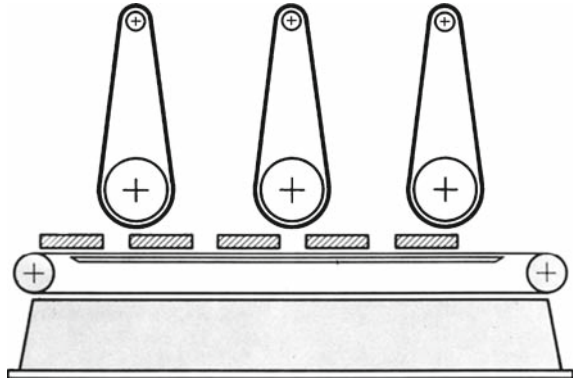


Figure 15.3
 Design principle of a partially automated flat grinding machine

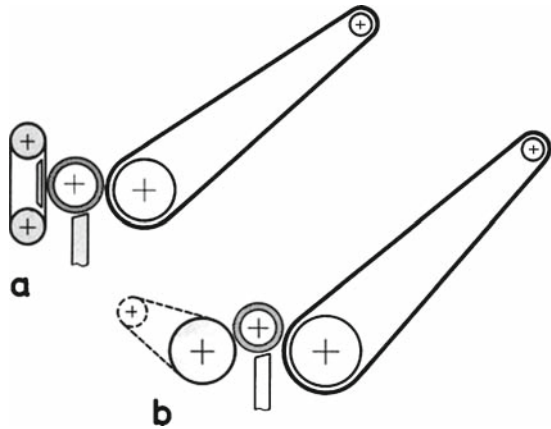


Figure 15.4
 Centreless abrasive circular grinders – design principle
 a) with regulating belt,
 b) with regulating wheel

In abrasive belt grinding, allowances of 0,1 to 0,2 mm are removed. Accuracy to size may be assumed from IT 10 to IT 11, feasible peak-to-valley height is from 2 to 4 μm .

16 Honing

Honing is the finest grinding method with bound abrasive grain and longitudinally oriented bonded abrasive segments (honoring stones).

Depending on the purpose and workpiece dimensions, the honing tool (Figure 16.1) is equipped with between 2 and 6 honing stones.

The honing tool simultaneously carries out a rotary motion and a stroke motion, which is generated by the honing machine (Figure 16.2).



Figure 16.1
Honing tool equipped with 6 honing stones
(photo by Gehring, Ostfildern)

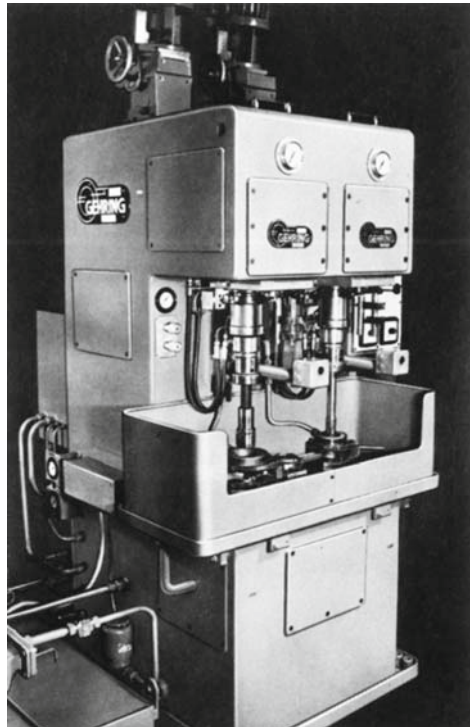


Figure 16.2
Honing machine with 2 spindles
working autonomously
(photo by Gehring, Ostfildern)

During honing, the tool or the workpiece, each one element, should have more than one degree of freedom in order to machine a hole coaxially.

The portable element is aligned according to the clamped part. For this reason, we differentiate between two different methods of honing:

1. Workpiece is fixed.
With a fixed workpiece, the honing tool is suspended on a pendulum bar and is movable (Figure 16.3a or b).
2. Workpiece is mounted so that it is floating or cardanic.
If the workpiece is movable, the honing tool is fixed on a rigid driving rod (Figure 16.3c).

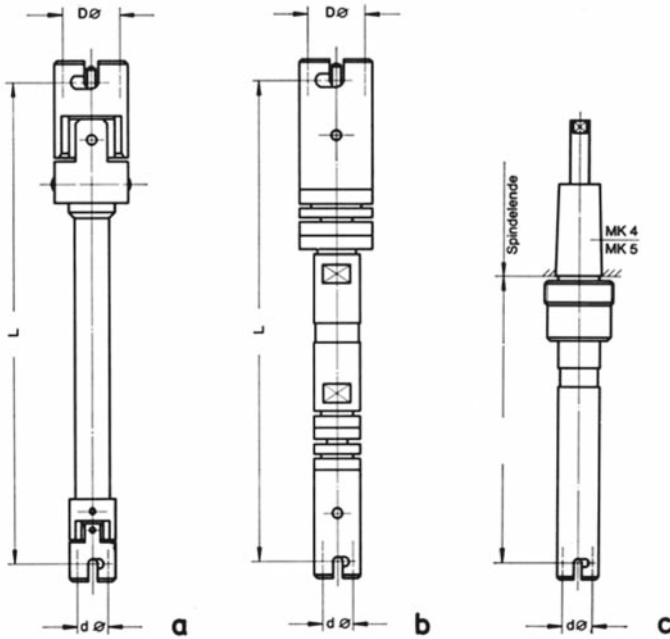
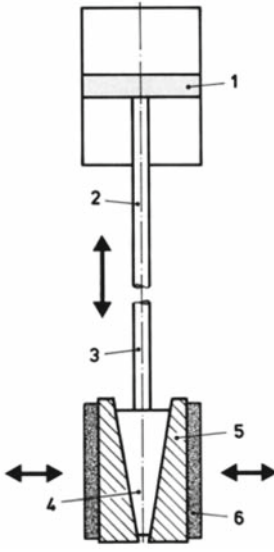


Figure 16.3

Driving rods for honing tools include a) double-joined joint rod with fixed stopper limit, b) double-joined pendulum rod with ball-and-socket joints and adjustable deflection limit, c) rigid driving rod, D connecting diameter for driving head, d connecting diameter for honing tool, L ordering length

During honing, material is removed by squeezing the honing stones into the hole that is being machined.

An expanding mechanism for the honing tool (Figure 16.4) allows the honing bars to be pressed hydraulically or mechanically to the surface to be machined through the honing motion.

**Figure 16.4**

Design principle of a hydraulic feeding attachment

- 1 Feeding piston,
- 2 Piston rod,
- 3 Feeding bar,
- 4 Expansion cone,
- 5 Stone holder,
- 6 Honing stone

Operating mechanism of the expansion attachment:

At the beginning of the honing operation, the honing tool travels into the hole. After this occurs, oil flowing from the top affects feeding piston 1. The developing pressure causes piston rod 2 to move downward onto feeding bar 3. The expansion cones 4 and 5 transform the axial motion in a radial motion according to their angle of inclination. When they do this, they expand the honing stones against the hole wall. If the honing procedure has ended, the feeding piston returns over a limited path. The honing stones are pulled back by tension springs. The honing operation concludes with moving the spindle out of the workpiece.

The specific contact pressure of the honing stones depends on the selection of the honing stone. The order of magnitude of the contact pressure values is shown below.

Diamond honing bars	300–600 N/cm ²
Cubic crystalline boron nitride bars	} 200–350 N/cm ²
Ceramically bonded honing bars	

The small chips formed during honing are flushed away immediately with the coolant (honing oil) at once.

The honed surface has the highest possible accuracy to form and size. It has fine crossing traces (grooves).

Honing stone dimensions

For cylindrical through holes, the honing stone length should be $2/3$ of the hole length (Figure 16.5).

$$L = \frac{3}{2} \cdot l$$

L in mm honing stone length
 l in mm hole length

For overrun, select approx. 1/3 of the honing stone length L

$$U = \frac{1}{3} \cdot L$$

U in mm overrun
 L in mm honing stone length

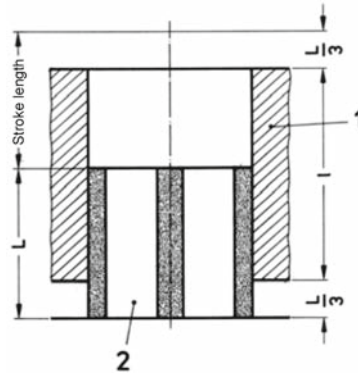


Figure 16.5
 Principle of honing through holes
 1 workpiece with through hole, 2 honing tool

Stroke length H results from tool length and overrun.

$$H \cong 0,8 \cdot L$$

H in mm stroke length
 L in mm honing tool length

Due to the required overrun of the honing stone, blind holes (Figure 16.6) should be designed with an undercut.

Since even in honing of blind holes the overrun should amount to approx. 1/3 of the honing stone length, the honing stone length is consequently:

$$L = 3 \cdot U$$

L in mm honing stone length
 U in mm overrun

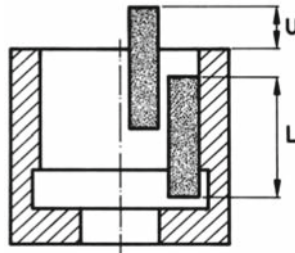


Figure 16.6
 Principle of honing blind holes

A honing tool for blind holes, with parallel rod adjustment, for the workpiece shown in Figure 16.6, is demonstrated in Figure 16.7.

During honing, the cutting speed is composed of two components due to simultaneous rotary- and stroke motions.

$$v = \sqrt{v_u^2 + v_a^2}$$

- v in m/min resultant cutting speed
- v_u in m/min peripheral speed
- v_a in m/min axial speed

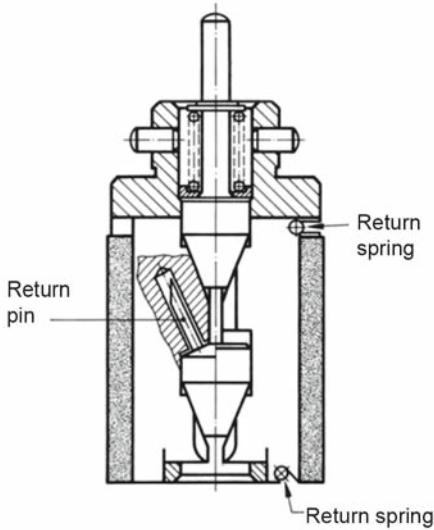


Figure 16.7
Honing tool for blind holes for the workpiece shown in Figure 16.6

Mean values for v_u and v_a are:

- $v_u = 10\text{--}15$ m/min
- $v_a = 15\text{--}20$ m/min

Additional reference values are collected in Table 16.1.

Table 16.1 Reference values for honing

Material	Peripheral speed v_u in m/min	Axial speed v_a in m/min
Steel, unhardened	22	12
Steel, hardened	22	9
Alloyed steels	25	12
Grey cast iron	28	12
Brass and bronze	26	14
Aluminium	24	9

The values in the table are applicable for pre-honing. For finish-honing, these values may be increased by 10 %.

Honing tool denomination

The honing tool name is composed of several code numbers. This short identifier specifies workpiece size and -structure.

Denomination of a honing tool (standard series) for 14 mm diameter, four-part, with 3 cones, 60 mm honing stone length and 200 mm connecting length (bayonet middle to bottom edge of the honing tool) of 200 mm is given in Figure 16.8.

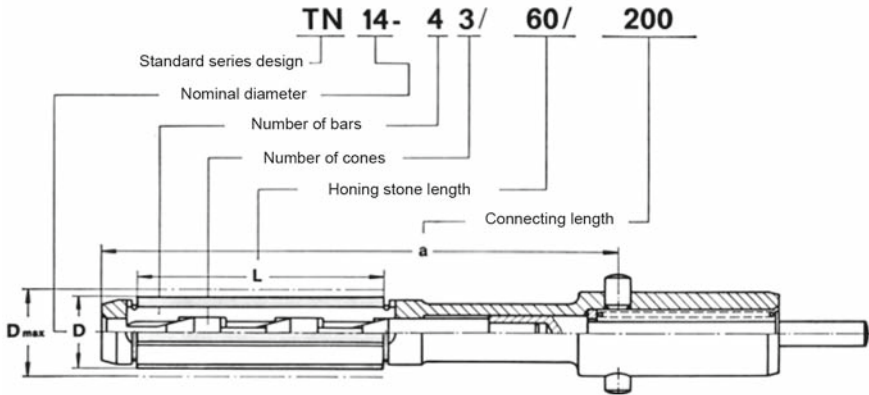


Figure 16.8
Names of honing tools

16.1 Application of the honing procedure

Honing as a finishing operation can be used for practically all materials, such as grey cast iron, hardened and unhardened steels, hard metal, non-ferrous metals and aluminium.

Honing is applied as a finishing operation after drilling or grinding of cylinder sliding surfaces, housing holes, holes in toothed gears and connecting rods, tubes and bushings (Figure 16.9).

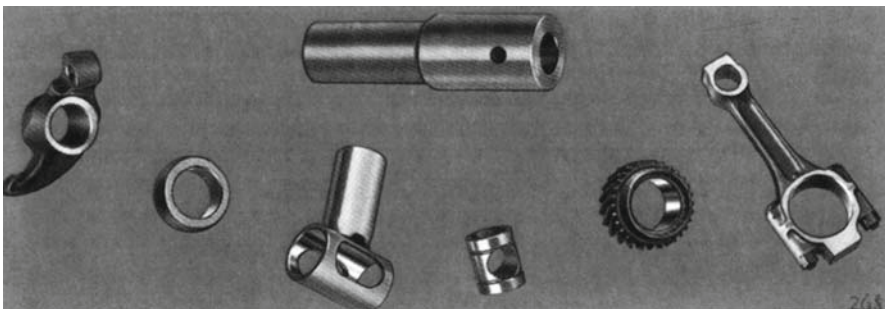


Figure 16.9
Honed holes on different workpieces

16.2 Achievable accuracies and allowances

Table. 16.2

Workpiece length in mm	at 25	At 300
Hole diameter in mm	at 20	80 to 100
Allowance, related to diameter, in mm	0,03–0,04	0,05–0,10
Accuracy to size	IT 4 to IT 5	IT 4 to IT 5
Roughness in μm	0,05–0,2	0,05–0,2

17 Superfinishing (shortstroke honing)

The superfinishing method, also called superhoning or shortstroke honing, is a precision finishing process in which a workpiece rotates and an abrasive wheel, which is pressed against the workpiece, simultaneously performs a rapid longitudinal vibration of only few millimetres (Figure 17.1).

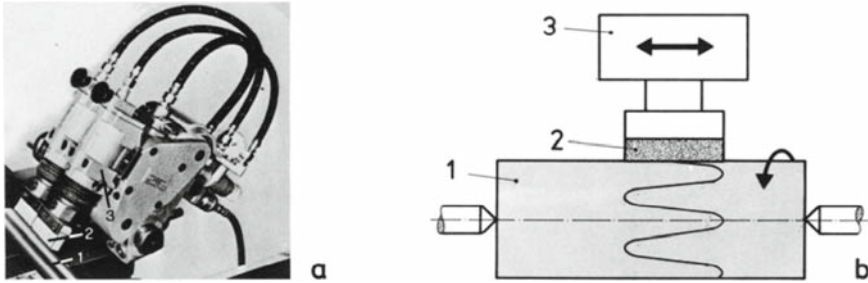


Figure 17.1

Superfinishing 1 workpiece, 2 abrasive wheel, 3 vibrating head, a) machine, b) principle

The abrasive wheel is similar to the honing stone. Sometimes the wheel or wheels is/ are fixed on a tool carrier, which carries out the oscillating motion. The slide on which the tool carrier is based generates the feed motion.

The overlapping of the two motions (the rotary motion of the workpiece and the oscillating – and feed motions of the tool) causes the grinding grains to pass over the workpiece surface on always different trajectories that are never the same. This results in particularly high surface qualities.

Due to the short longitudinal motion of the abrasive wheel, which is similar to honing, the method is also called “shortstroke honing”.

Since the abrasive wheel carries out a vibrational motion (back and forth motion), the technique is also called “superhoning”.

In lieu of the term “superfinishing“, the terms “precision honing“ or “superfine honing” are also used. The German equivalent of these terms is derived from honing.

17.1 Application of superfinishing

This method is used when, in addition to the best possible surface quality, the structure of the machined workpiece, up to the outermost load-bearing layer, needs to be totally heterogeneous. If the part’s microstructure has to fulfil high requirements, then a superfinishing technique is indicated. Requirements like these occur, for example, in the case of bearing yokes, heavily loaded bearing pins on shafts and heavily loaded anti-friction bearings.

As a result of superfinishing, in these elements, the surface structure is refined by removing the surface layer, which is dispersed by the machining procedure to such an extent that, for instance, breaking in of rotating machine parts is unnecessary. Moreover, the elements machined this way have good wear characteristics.

With superfinishing, peak-to-valley heights from 0,1 to 0,4 μm can be achieved, the measuring accuracy ranges from IT 3 to IT 4. Allowances from 0,002 to 0,003 mm are sufficient.

18 Lapping

Lapping is a precision grinding technique with loose grains, in which the workpiece and the tool slide over each other in constantly changing directions.

In combination with oil, fine grinding grains form a lapping paste, or, with petroleum, a lapping fluid. This paste is deposited on the lapping tools, the lapping plates (Figure 18.1).

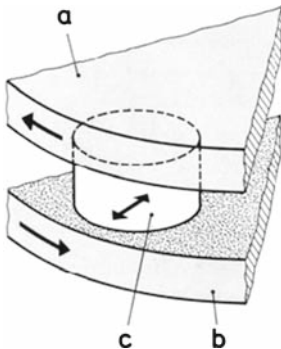


Figure 18.1
Surface lapping principle
a) upper lapping plate,
b) bottom lapping plate,
c) workpiece

The lapping grain moves due to the irregular sliding of lapping plate and workpiece on each other.

During sliding, both tool and lapping plate are abraded. The rate at which each part is machined depends on its materials. Lapping plates are predominantly manufactured from grey cast iron (special cast material) with a strength of 2000 N/cm^2 .

The workpiece motion results from frictional coupling or a forced guidance as shown in Figure 18.2. In the configuration shown in Figure 18.2, the workpiece holders are in contact with a fixed rim of the gear (lying outside) and a driving ring gear (inside).

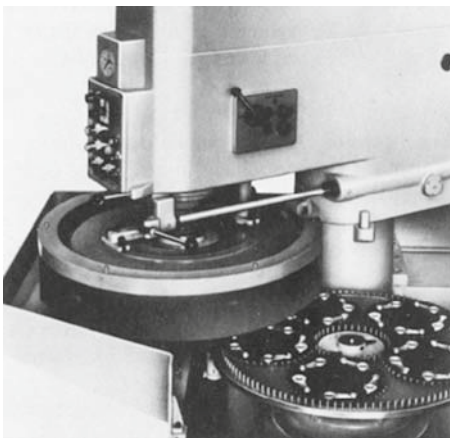


Figure 18.2
Hydraulic two plate-lapping- and
precision grinding machine, type
ZL 800 H, with planetary driving
attachment
(photo by Hahn & Kolb, Stuttgart)

In the configuration of workpiece holders, it is necessary to look for an optimal solution for each individual application.

Internal- (hole lapping) and external cylindrical lapping are executed on lapping machines with a vertical spindle, whose rpm can be controlled.

The circumferential speed of the lapping arbour should be between $v = 10$ to 20 m/min.

In most cases, the oscillating stroke motion is generated hydraulically.

Lapping tools for holes (Figure 18.3) consist of a hardened tapered arbour, (cone ratio 1 : 40) made of steel, which bears the intrinsic lapping sleeve made of cast iron.

The sleeve is slotted in order to readjust the lapping sleeve diameter, which becomes smaller as a result of the drive.

During lapping, the grinding grains break as a result of pressure between lapping tool and workpiece.

Consequently, new, smaller lapping grains are formed, continuously improving the surface during the lapping procedure.

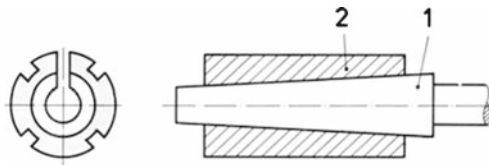


Figure 18.3
Internal cylindrical lapping tool
1 lapping arbour, 2 lapping sleeve

18.1 Application of the lapping technique

Plane lapping is used for face machining of piston rings, stampings, coupling rings, toothed segments and components for measuring devices (Figure 18.4).

Holes of bushings, sleeves, pump cylinders are finished with internal cylindrical lapping.

Lapping is applied if surface roughness values less than $R_t = 0,5 \mu\text{m}$ and maximum accuracy to shape are required simultaneously. Accuracy to size is from IT 4 to IT 5, allowances range from 0,02 to 0,04 mm.

18.2 Dicing (wire cutting with slurry)

Dicing or wire cutting with slurry is both one of the oldest and one of the newest manufacturing techniques known to humankind. On the one hand, it was being used to cut jade in 1900 BC. On the other hand, however, it has developed into a special technology within lapping machining only since the 1980s. It is a very productive method primarily used to fabricate thin and very precise slices of brittle and hard



Figure 18.4
Typical lapping workpieces (*photo by Hahn & Kolb, Stuttgart*)

materials, such as semiconductor materials, ceramic or glass. But it is also possible to machine less brittle-hard materials like aluminium or molybdenum.

The working principle of wire cutting with slurry, in which a thin and extremely strong wire is used as the lapping tool, is illustrated in Figure 18.5a. This wire, commonly a steel wire enrobed in brass, is guided repeatedly at high speed v_D of 5 to 10 m/s upon guiding rollers, so that a parallel wire grid is formed. The cutting procedure is implemented by wetting the wire with a lapping fluid (slurry) and a feed motion of the workpiece through the wire field. The feed rate depends both on material and the size, as well as the number, of the slices to be produced. The lapping fluid consists of a fluid carrying phase, such as oil, water or glycol, and the lapping medium, mostly silicon carbide, but also corundum and diamond. The technique's high productivity rate results most of all from the fact that thousands of slices can be produced at the same time. [34]

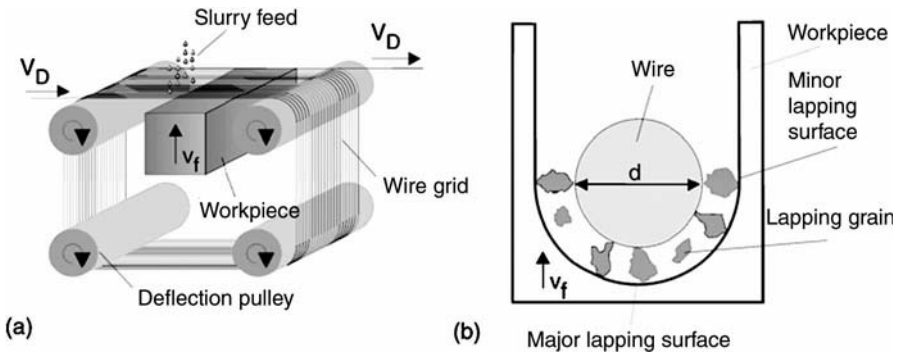


Figure 18.5

a) Dicing or wire cutting with slurry – technological principle, v_f feed rate, v_D wire speed

b) cross section of the lapping gap

(TU Dresden, Department of Cutting- and Abrasion Technology) [34]

In contrast to the lapping techniques commonly used, it is not the major lapping surface that is machined that is significant for the shape generation of the cut slices (Figure 18.5b), but rather the minor lapping surface. Furthermore, the heterogeneous direction of motion that appears in conventional lapping does not occur in dicing. The wear of the lapping grains in their directed motion is reflected in the result of the work. Hence the typical trumpet shape of the lapping gap and thus an increase in thickness of the cut slices in the direction of wire motion is reflected (Fig.18.6).

This shape deviation of the slices is significantly determined by the dispersion of the sizes of the lapping grains. A stronger inclination of the slices arises from high dispersion, because, first of all, the biggest grains take part in the lapping procedure, and it is only once they are worn that the medium-size grains begin to have an effect and define the distance between wire and slice surface. Depending

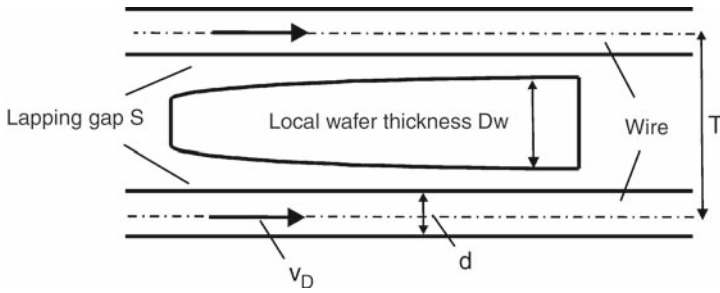


Figure 18.6

Typical increase in wafer thickness in wire speed direction resulting from worn lapping medium, d wire diameter, v_D wire speed, T partition
(TU Dresden, Department of Cutting- and Abrasion Technology) [34]

on the material used and the type of the lapping medium, thickness differences and deviations from parallelism of less than $10\ \mu\text{m}$ are feasible. Dicing or wire cutting with slurry can be applied to produce slices between 100 micrometers and a few millimetres thickness. Typical surface qualities are less than $2,5\ \mu\text{m}$ for R_z , or less than $1\ \mu\text{m}$ for R_a .

This method is mostly used to manufacture thin slices that are difficult or impossible to produce with other methods, such as metal sheets for rolling. The minimal losses due to cutting, arising from the use of very thin wires with diameters from approx. 100 to 200 μm and correspondingly fine lapping media, make the method very economical as well. Dicing or wire cutting with slurry is an established technique first of all in the production of thin slices of high-cost materials. It is applied in the mass production of silicon wafers for the electronics and solar industries (Figure 18.7). The new generation of silicon wafers, with a diameter of 300 mm, is only can only be produced with dicing lapping.

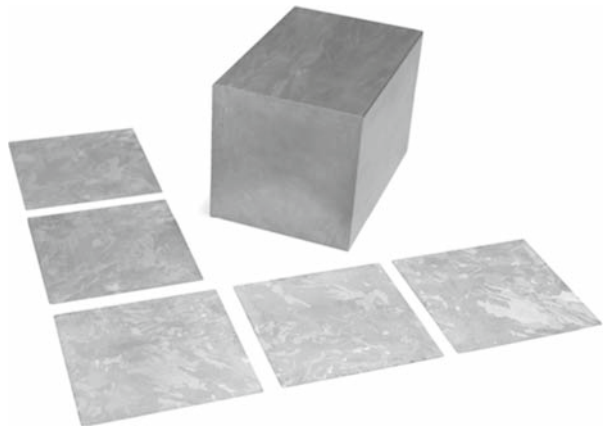


Figure 18.7

Example of use: silicon slices cut from a block (for solar cell manufacturing)
(photo by TU Dresden, Department of Cutting- and Abrasion Technology)

19 Further refinement of the cutting materials

19.1 High-speed steels

The outstanding characteristics of high-speed steels are:

- Great toughness,
- Low-cost,
- Sound machinability of the cutting material.

Even today, twist drills, taps, dies, gear cutting- and broaching tools are predominantly made of high-speed steel.

Significant improvements can be made through the coating of high-speed steels. The coating is performed with the physical vapour deposition (PVD method).

During the coating of high-speed steel, the coating temperature is approx. 500 °C. At this temperature, it is still possible to coat heat-treated tools without distortion. The materials used as hard deposits are

titanium nitride (TiN), titanium carbonitride (TiCN), titanium aluminium nitride (TiAlN) or titanium aluminium oxinitride (TiAlON),

which are coated at a thickness of 2 to 4 µm. Coated high-speed steels make possible an increase in power during machining due to longer tool life or higher cutting speeds:

- tool life increase: 100% to 500%,
- increase in cutting speed: 50%

with the same tool life, in comparison to uncoated tools.

19.2 Cemented carbides

19.2.1 Uncoated cemented carbides

Cemented carbides are cutting materials produced by powder metallurgy. The main components are tungsten carbide (TC), incorporating hardness, and cobalt (Co) as binder. For grades to machine steel, additional hard materials are added – mostly composite carbides based on titanium, tantalum and niobium – in lower percentages. The carbides are responsible for hardness and wear resistance, whereas the binder determines the toughness characteristics. Cemented carbides are naturally hard, which means that their characteristics cannot be altered like those of steel can be by means of heat treatment.

In comparison with high-speed steel, the most essential parameters of cemented carbides are their fundamentally greater hardness, on the one hand, and lower level of toughness, on the other hand:

Parameter	High-speed steels	Cemented carbides ¹
Hardness (HV 30)	700 ... 900	1300 ... 1800
Flexural strength (N/mm ²)	2500 ... 3800	1000 ... 2500
Heat resistance to	600 °C	> 1000 °C

¹ Cemented carbide sorts for machining

Cemented carbide is available in many varieties with very different properties. Consequently, a suitable variant is available for almost all types of machining, from easy finishing to machining of hard work materials. In addition to this spectrum, varieties for all workpiece materials are available.

At present, the performance of cemented carbides is being significantly improved due to the use of finer and finer grain sizes. Traditional grades of cemented carbide grades for machining make use of medium grain sizes from 1 to 2 μm ; today, for ultra-fine grains, grits of 0,2 to 0,4 μm are being used. The significance of this trend is the simultaneous and tremendous increase in the principal (and opposing) parameters “hardness – tool life“ and “toughness – reliability“.

19.2.2 Cermets

Cermets are cemented carbides, in which titanium carbonitride (TiCN) is used to provide the majority of the hardness instead of tungsten carbide, and a compound of nickel and cobalt serves as the binder. This difference in composition makes the cermets more heat resistant, on the one hand. On the other hand, it diminishes the material's toughness.

Consequently, cermets are used for finishing and for operations with minimal requirements in terms of cutting edge toughness, preferentially for machining of steel.

19.2.3 Coated cemented carbides

An additional coating offers a significant increase in the performance of the cemented carbides, resulting in much higher tool life and/or increased cutting speeds.

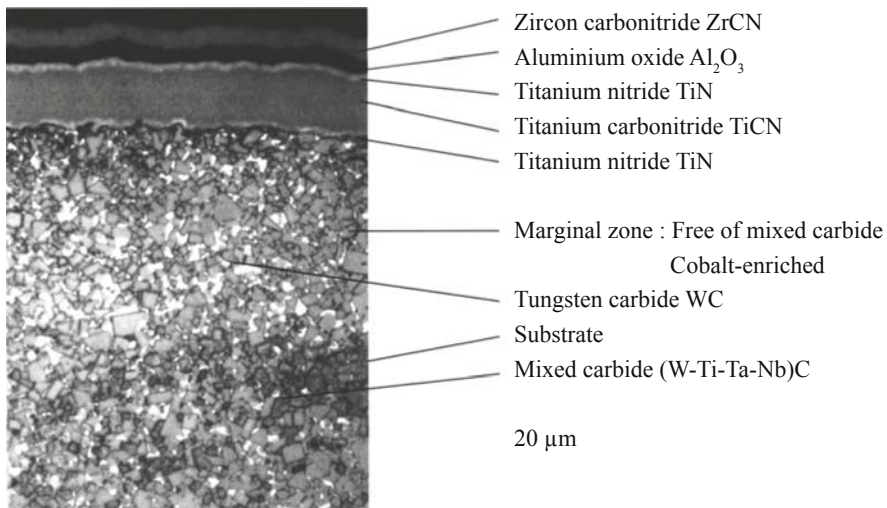


Figure 19.1
Micrograph of a multi-layer coating

Cemented carbides are preferentially coated by means of chemical vapour deposition (CVD). During this process, hard materials are made through chemical reactions in the coating furnace at temperatures from 850 to 1000 °C from gases that are fed in. These hard materials are deposited in a solid coat on the cemented carbide. Commonly used and proven hard materials are, for instance, titanium carbide (TiC), titanium carbonitride (TiCN), titanium nitride (TiN), aluminium oxide (Al₂O₃) and zircon carbonitride (ZrCN), of which multi-layer coats almost exclusively deposited (Figure 19.1). Total coat thickness may be up to 25 µm.

In certain cases, cemented carbides are also coated according to the PVD method. This stands for physical vapour deposition, whereby single coats of titanium nitride, titanium carbonitride, titanium aluminium nitride (TiAlN) or titanium aluminium oxinitride (TiAlON) are applied.

Coated cutting edges are typically characterised by their fillets, whose rounding radius is at least at the layer thickness level. In most CVD coats, this radius is substantially higher to avoid embrittlement of the cutting edge due to coating. For this purpose, radiuses from 20 to 100 µm – depending on the use of the cutting edge (roughing or finishing) – are common practice.

Coated cemented carbides are suitable to machine all steels and cast iron materials, as well as high-temperature alloys based on nickel or cobalt. In industrial production, for turning and drilling, coated indexable inserts are almost always used, and these inserts are also used in the majority of milling applications. Uncoated cutting edges are used for machining only on machines with low input power or if it is necessary to have very keen cutting edges.

Light- and non-ferrous metals are still machined with uncoated cemented carbide. The physical properties of the cutting materials are summarised in Table 19.1.

Table 19.1 Properties of the cutting materials

Properties	High-speed steel	Cemented carbide	Ceramic	Natural diamond
Density g/cm ³	8,0 ... 9,0	6,0 ... 15,0	3,2 ... 4,5	3,5
Vickers hardness (macro h.) HV 30	700 ... 900	850 ... 1800	1400 ... 2100	8000 ... 10000
Compressive strength N/mm ²	3000 ... 4000	3000 ... 6400	2500 ... 5000	2000
Flexural strength N/mm ²	2500 ... 3800	1000 ... 3400	400 ... 900	400
Temperature stability to K	870	> 1300	> 1800	970
Young's modulus 10 ⁻⁴ N/mm ²	26 ... 30	47 ... 65	30 ... 45	90 ... 100
Reciprocal value of Young's modulus (dilation). (RT = 1,273°K) 10 ⁻⁶ /K	9 ... 12	4,6 ... 7,5	2,6 ... 8,0	1,5 ... 1,9
Thermal conductivity (RT) $\frac{W}{Km}$	15 ... 48	20 ... 80	14 ... 30	138

Figure 19.2 shows hardness and wear resistance as a function of flexural strength and toughness for the individual cutting materials.

The higher the hardness and wear resistance, the lower the toughness.

The ideal cutting material would be not only very hard, but also very tough. However, this kind of cutting material does not yet exist.

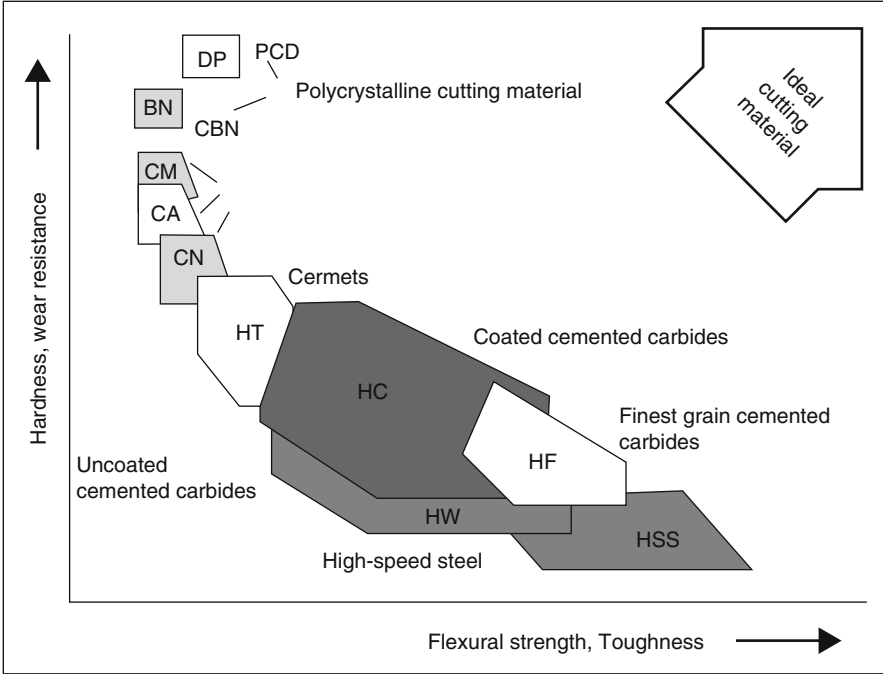










Figure 19.2
Hardness and toughness, assigned to different cutting materials

Table 19.2 Coated cemented carbides with recommended ranges of application (excerpt of a company documentation by Kennametal, Hertel, Fürth)

<p>KC520M</p>  <p>TiAlN HM</p>	<p>Composition: Coated type of cemented carbide, with a 4 µm thick TiAlN coating (PVD)</p> <p>Recommended use: KC520M is a new sort of cemented carbide, which was specifically designed for medium machining (G) of spheroidal-graphite cast iron. KC520M can be used either with or without coolant.</p>
<p>KC525M</p>  <p>TiAlN HM</p>	<p>Composition: Coated cemented carbide type with a 4 µm thick TiAlN coating (PVD)</p> <p>Recommended use: New universal cemented carbide type for milling of steel, stainless steel and hard-working materials. KC525M can be used both with/without coolant. To be applied for light and medium machining (L and G)</p>
<p>KC715M</p>  <p>TiN TiCN TiN HM</p>	<p>Composition: KC715M is a new cemented carbide type, which is excellently suited to machining without coolant (dry machining). The wear-resistant substrate is highly resistant to thermal changes.</p> <p>Recommended use: The material is mainly used for light and medium machining (L, G range of steels, stainless steels and cast steel)</p>
<p>KC725M</p>  <p>TiN TiCN TiN HM</p>	<p>Composition: Coated cemented carbide type with a 5 µm thick PVD multi-layer coating (TiN/TiCN/TiN)</p> <p>Recommended use: KC725M is a high-performance type used to mill steel, stainless steel and spheroidal-graphite cast iron. Because of its high resistance to thermal shock, this type is excellently suited to machining with or without coolant. Major range of application is medium to hard machining (G, H)</p>
<p>KC735M</p>  <p>TiN HM</p>	<p>Composition: Coated cemented carbide type with a 4 µm thick PVD coating. This type is a special combination of high toughness and sound wear resistance.</p> <p>Recommended use: Even with the most demanding toughness requirements, KC735M achieves best results in the regions G and H. this type is suitable for milling with coolant.</p>
<p>KC915M</p>  <p>Al₂O₃ TiN HM</p>	<p>Composition: Coated cemented carbide type with a 7 µm thick CVD multi-layer coating (TiN/Al₂O₃)</p> <p>Recommended use: KC915M is a multi-purpose type for milling of cast iron. This cutting material is the first choice for light and medium (L, G ranges) machining. KC915M is suitable for milling without coolant.</p>
<p>KC920M</p>  <p>Al₂O₃ TiN HM</p>	<p>Composition: Coated cemented carbide type with a 5 µm thick CVD multi-layer coating (TiN/Al₂O₃)</p> <p>Recommended use: KC920M is a multi-purpose type used to mill cast iron. This cutting material is the first choice for light, medium and hard machining (L, G, H). KC920M is suitable for milling either with or without coolant.</p>
<p>KC930M</p>  <p>TiN TiCN TiN HM</p>	<p>Composition: Coated cemented carbide type with an 8 µm thick CVD multi-layer coating (TiN/TiCN/TiN)</p> <p>Recommended use: KC930M is a multi-region type used to mill steel and spheroidal-graphite cast iron. Ranges of application are light, medium and hard machining (L, G, H).</p>

19.3 Ceramic

In ceramics, the following types are distinguished:

19.3.1 Oxide ceramic, white (clean ceramic)

The main constituent of the white oxide ceramic is Al_2O_3 . To enhance toughness, low volumes of zirconium oxide ZrO_2 are added.

19.3.2 Oxide ceramic, black (mixed ceramic)

This is a mixed ceramic, which, in addition to aluminium oxide, consists of metallic hard materials, such as titanium carbide TiC and titanium carbonitride TiN . This way, compressive strength and abrasion resistance greater than those of white ceramic can be achieved.

19.3.3 Nitride ceramic

This type belongs to the non-oxidic cutting materials, based on Si_3N_4 .

This ceramic is characterised by good fracture toughness and high thermal shock resistance. For this reason, it is suitable for roughing of grey cast iron.

19.3.4 Whisker ceramic

This is a kind of oxide ceramic with additionally interstratified fibres (whiskers), mostly of silicon carbide (SiC). Thus, the toughness properties are clearly enhanced.

19.3.5 Coated ceramic

In rare cases, ceramic is coated with materials based on silicon nitride to further increase the tool life characteristics.

Table 19.3 Ceramic cutting materials

Ceramics	Approximate composition	Ranges of application		
Oxide ceramics, white	3–15 weight percentage ZrO_2 residual Al_2O_3	Grey cast iron, case-hardening- and tempering steels, suitable for: high v_c , lower feed values		
Oxide ceramics, black	5–40 weight percentage TiC/TiN additionally up to 10 weight percentage ZrO_2 residual Al_2O_2	Chill casting, hardened steel suitable for: high v_c , low feed values		
Nitride ceramic	<table style="display: inline-table; vertical-align: middle;"> <tr> <td style="border: none;"> 0–7,5 weight per. Y_2O_3 0–17 weight per. Al_2O_3 0–3 weight percentage MgO </td> <td style="border: none; padding-left: 10px;"> } As sintering additives </td> </tr> </table> <p>Additionally up to 30 weight percentage TiC/TiN residual Si_3N_4 (silicon nitride)</p>	0–7,5 weight per. Y_2O_3 0–17 weight per. Al_2O_3 0–3 weight percentage MgO	} As sintering additives	Grey cast iron; steels with high nickel content, suitable for: rough machining with medium v_c
0–7,5 weight per. Y_2O_3 0–17 weight per. Al_2O_3 0–3 weight percentage MgO	} As sintering additives			

19.4 Polycrystalline cutting materials

19.4.1 Polycrystalline diamond (PCD)

Polycrystalline (multi-grained) diamond is made synthetically of carbon under high pressure and at high temperature. PCD is – after the natural diamond – the hardest cutting material by far; for this reason, it provides unequaled wear resistance.

This diamond is used in series production to machine aluminium alloys with high silicon content (preferentially above 12%), which are extremely abrasive. Typical workpieces are crankcases and cylinder heads in the car industry. PCD is also used to machine fibre-reinforced plastics, because the keen cutting edges avoid delamination of the laminate. The material's hardness also results in long tool life in spite of very abrasive fibres. PCD may not be used to machine ferruginous workpiece materials.

19.4.2 Cubic boron nitride (CBN)

Polycrystalline (cubic) boron nitride is made of hexagonal (“standard”) boron nitride using a procedure similar to PCD. The most important property of CBN is its high heat hardness. Consequently, CBN is outstandingly suited to machining of hardened steel- or cast workpieces, given that hardness values up to 68 HRC can be machined.

19.5 Marking of (hard) cutting materials

The hard cutting materials (these are all cutting materials, except for high-speed steels) differ greatly in composition and properties. However, they are nevertheless used for the same machining tasks, wherein cutting conditions and work results may be very different. Thus, for instance, to turn cast iron, one may use either uncoated or coated cemented carbide, white or black oxide ceramic, nitride ceramic or CBN. For these materials, the cutting speed values range from 60 to 1200 m/min as a function of the cutting material.

To better represent the hard cutting materials, the standard ISO 513 was reworked and is now valid in its extended version. In this version, the current “Classes of cutting application” according to ISO 513 are prefaced with letters to identify the cutting material group.

These are:

Table 19.4 Marking of hard materials according to ISO 513

Symbol	Cutting material group
HW	Uncoated cemented carbide, based on tungsten carbide
HF	Fine grain hard metal, grain size less than 1 μm
HT	Uncoated cemented carbide, based on titanium carbide or -nitride (cermet)
HC	Cemented carbides as aforementioned, but coated
CA	Oxide ceramic based on Al_2O_3 , also with other oxides
CM	Oxide ceramic based on Al_2O_3 and other non-oxidic constituents
CN	Nitride ceramic based on Si_3N_4
CR	Fibre-reinforced ceramic based on Al_2O_3 (whisker ceramic)
CC	Ceramics as aforementioned, but coated
DP	Polycrystalline diamond (PCD)
DM	Monocrystalline (natural) diamond
BH	Polycrystalline boron nitride with high PCB content
BL	Polycrystalline boron nitride with low PCB content
BC	Polycrystalline boron nitride as aforementioned, but coated
In addition to the 3 machining main groups P, M and K, which have been commonly recognized up to now, the new standard ISO 513 will contain other main groups, with the following content:	
P	Unalloyed and alloyed steels (as before)
M	Rustproof austenitic steels (as before)
K	Unalloyed and alloyed cast iron (no other additional workpiece materials)
N	Non-ferrous metals and non-metals
S	Hard work alloys based on nickel or cobalt or titanium
H	Hardened iron materials (steel and cast materials)

Within each of these main groups, the individual cutting material grades are assigned according to their toughness- and hardness properties to different cutting classes (application classes), which are labeled with numbers.

Thus, the range of application of a cutting material type is indicated by specifying the cutting material recognition letter and the cutting class (application class), for instance HC-P25 or CA-K10 or BH-H05.

20 High speed cutting (HSC)

20.1 Definition

In certain contexts, high speed cutting is only defined as machining at high cutting speeds (spindle speeds) and/or at high feed rates in order to achieve short machining- or lead times. However, for a reasonable classification, one has to consider the material to be machined (soft- or hard machining), the cutting materials and the metal removal rate.

The English term HSC (**High Speed Cutting**) is commonly used for high speed machining even in German-speaking countries. For this reason, it will be used in the following discussion.

20.2 Introduction to high speed cutting (HSC)

High speed machining was patented by SALOMON in the 1930s (German Reichspatent no. 523594, in 1931). But, as with many inventions, industrial use of the method only became possible after the technical preconditions had been established. In this case, those prerequisites included developing and designing HSC machines and making available the corresponding cutting materials, to name only a few.

For this reason, the development of high speed cutting intrinsically started in Japan at the beginning of the 1980s. But the potential of this procedure was quickly recognised in Germany as well, and it was particularly influenced by the Institute for Production Engineering and Metal Cutting Machine Tools (German abbrev. PTW, which stands for Institut für Produktionstechnik und Spanende Werkzeugmaschinen) of the Technische Hochschule Darmstadt. This potential includes

- An increase in metal removal rate
- A decrease in cutting forces
- Improved surface quality
- Reduced head entry into the workpiece.

Qualitative relationships in high speed machining are illustrated in Figure 20.1.

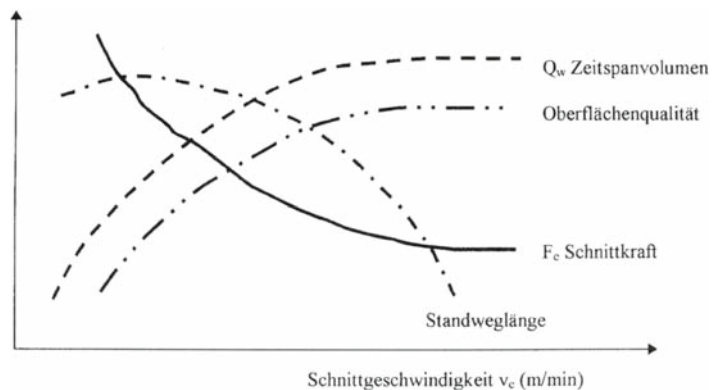


Figure 20.1
High speed cutting parameters

The palette of materials to be machined ranges from light metals to plastics (fibre-reinforced) and ceramic to cast and steel materials (including hardened).

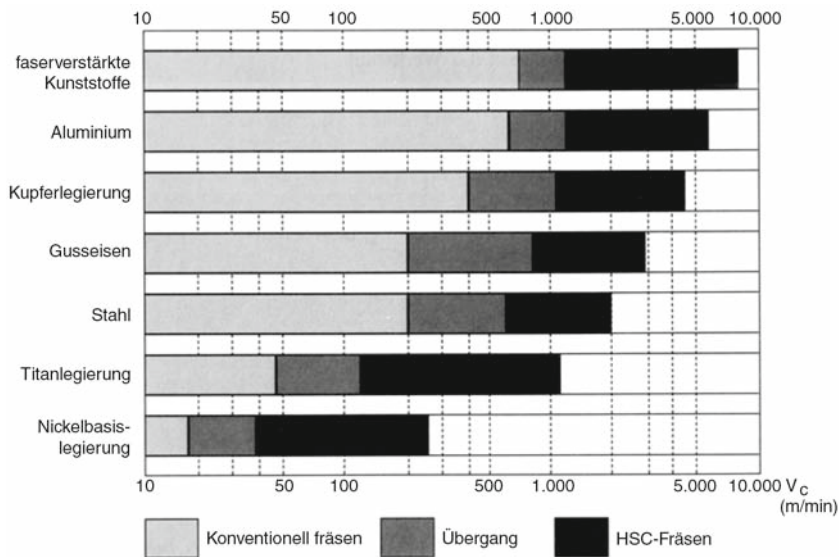
Whereas the HSC technology found its first use in the aerospace industry, present applications come not only from tool- and diemaking, but also the production of high-precision parts, as well as thin-walled parts.

Table 20.1 Ranges of HSC applications

Ranges of application	Examples
Aerospace industry	Structural parts (ends)
Composite machining	Turbine blades
Automotive industry	Pattern making Forming dies (sheet metal forming) Injection moulds
Consumer goods-, electrical-and electronic industry	Electrodes (graphite/copper) Die inserts (hardened) models
Handling technology, energy ge-neration	Compressor wheels, blades, housings

As a function of the material to be machined, the cutting speeds are approximately 5 to 10 times higher than those in the conventional region, as can be seen in the figure below.

Table 20.2 Cutting speeds for high speed cutting



HSC not only means to machine at high cutting speeds and/or high feed rates, but it should also be regarded as a machining procedure employing carefully aligned methods, tools and machines. In milling, HSC does not necessarily mean using very high spindle speeds, since, even with milling cutters of greater diameter, HS machining can be performed at lower speeds. During finishing of hardened steel materials,

when using HSC, we have cutting speed- and feed values that are approximately 4 to 6 times greater than the conventional cutting values. HSC is applied more and more to highly productive machining of housings, small-sized and medium-sized components – from roughing to finishing, sometimes even to fine finishing.

20.3 Application of high speed cutting

20.3.1 High speed cutting techniques

High speed cutting, with many advantages in productivity and efficiency, currently finds its way into almost every field of machining.

Comparing the kinematic background of the turning and milling procedures, in turning, where the kinematic mechanism is based on a rotating workpiece, it is much more difficult to cope with the huge, quickly rotating weights and safe workpiece chucking at high speeds, and thus the conditions for HSC use are considerably less appropriate than in milling in general. Consequently, high speed turning does not have wide industrial application yet.

Unlike milling, in which the short chips resulting from technology are beneficial for high speed machining, during drilling at high cutting speeds, long chips are formed in a continuous cut, which moreover have to be taken out of the hole. In drilling, it is impossible to quickly discharge that appears during machining together with the chip, as it is in milling. During drilling, the heat is absorbed by the drill and the wall of the hole. High speed drilling is impossible without internal cooling of the solid carbide drills that allows the cutting fluid to go directly to the contact positions between the cutting edges and the material (see page 115). Here the cutting fluid plays an additional part by moving the chip as well. Drilling is defined as a high speed procedure if the cutting values exceed the conventional ones by a factor of at least 2, since, even here, significant differences in terms of the materials to be machined and their absolute values appear. Further use of high speed drilling is significantly influenced by trends in the tool domain and available HSC machines.

Consequently, the main focus of HSC is on the milling technique. Thus the following considerations are dedicated to milling technology.

As mentioned in the introduction, high speed machining will only succeed if there is a perfect interaction among machine tool, tool, workpiece- and tool clamping technology, cutting fluids, cutting parameters, such as spindle speeds, cutting speeds and feeds, and the CNC.

High speed machining of aircraft components, such as aluminium formers and ribs, whose cutting share sometimes requires up to 95% of the total energy or efforts of the process, began to be used industrially in the mid eighties. The cutting speeds that can be achieved currently range from 1000 to 7000 m/min, and maximal feeds are up to 30 m/min.

Due to the low specific cutting forces, it is also possible to properly mill also other light alloys in automotive engineering (aluminium- and magnesium castings or dummy blocks made of aluminium) at high cutting speeds and feeds. Particularly

tough cemented carbides (diamond coated) and polycrystalline diamond have been proven as cutting materials.

High speed milling of steel and castings, especially finishing, is becoming more and more important, because production times are dramatically reduced thanks to the much higher feed rates, that are possible here. It is also the case that, at high feed rates, the diminished line distance offers much better near-net-shape behaviour, that is, a better approximation of the milling contour to the nominal contour, which, in turn, cuts down on the manual rework necessary and secures a competitive edge, particularly in the tool- and diemaking business.

For hardness values from 46 to 63 HRC, high speed milling may replace even the costly cavity sinking technology by choosing suitable milling cutters and selecting the appropriate technological parameters. It is possible to mill the forging- and deep draw dies almost into their final shape. For example, a steel forging die part of an open-end wrench was milled, 54 HRC, in 88 minutes. In comparison, it took 17 hours to conventionally machine this part – time for cavity sinking and repolishing.

As a result of many investigations on milling strategies, as a rule, in high speed machining, down milling is the method of choice. During up milling, because of the tooth's sliding phase when starting the cut and welding on the chips, increased tool wear and sometimes chipping of the cutting edge appear. Due to the geometry of the approach during milling with end mill, which depends on rotation direction of the milling spindle, the kinematic tool direction (workpiece direction) and the location of the material to be cut, up milling is inevitably applied, because it is not reasonable to alter the spindle rotation direction during machining. For this reason, the milling technology has to be optimised by appropriate travelling strategies.

Another significant consideration in high speed milling is the sudden change of the milling cutter path direction that is sometimes necessary. For machining at very high feed rates, it is necessary to consider the accelerating- and decelerating characteristics of the used machine and the "Look ahead" function of the CNC, characterised by the control's capacity, long before making an abrupt change of direction. If the workpiece contour to be milled demands frequent abrupt changes of the milling path direction, then the machine has to reduce its velocity as often as necessary and speed up again. As a function of the possible machine parameters and the "Look ahead" option of the control, significant losses in time and also measurable contour errors can be detected. Problems due to the relatively high contact width in combination with the abrupt change of the milling path direction occur particularly in acute internal corners of a part contour, which leads to very poor cutting conditions, and, in turn, higher loads and consequently tool wear.

20.3.2 HSC machines

High speed machining is only possible if all elements of the system Machine tool – Tools – Workpiece are optimally aligned. The stringent kinematic and dynamic requirements that must be fulfilled by the corresponding machine design for different purposes of use demand modular approaches with innovative solutions in

machine building - frequently mineral castings for the frames-, axis concepts and drive- and control technology.

For this reason, the implementation of high speed milling technology in industry resulted in a wide variety of high speed machining centres and machines, as required for different machining tasks, such as light alloy machining in the aerospace industry, with cutting requiring a great expenditure of energy, or finishing of hardened steel dies in the tool- and diemaking industry. This variety of HS machinery can only be touched on in this textbook. Some of the significant assemblies and components of a high speed machine system will be discussed briefly.

Motor spindles with ball bearing have been proven effective as main spindles, because they provide good value for money regarding the required cutting capacity and the spindle capacity. As previously mentioned, the hollow shaft short taper (German abbrev.: HSK) has been proven and established as an interface to the tool.

Among the feed drives, the electromechanic servo linear motors are dominant, but the linear direct drives, which enable much higher feed rates (> 100 m/min) and acceleration values of 2 to 3 g ($20\text{--}30$ m/s²) are out of the experimental stage.

For small- and medium-sized HSC machines, the machine frames are to an aver greater extent made of mineral casting, whose attenuation is 6 to 10 times higher than for grey cast iron, and whose thermal conductivity is 25 times lower than for steel, to give only a few properties (see Figure 20.7). For large-sized machines, the great stiffness required has to be achieved by means of the appropriate welded steel constructions. In this domain, innovative designs based on parallel kinematic mechanisms carried out as non-Cartesian axis concepts (hexapods, tripods) are superior, both in terms of structural stiffness and thermal stability (see Figure 20.8).

Concerning the axis allocation, the three major axes X, Y and Z are, as a rule, dimensioned as Cartesian linear axes. In addition to these, circular- and swivelling axes are implemented for the transition from 3- to 5-axis milling in different variants. Non-Cartesian axis concepts (e.g. hexapods) are particularly suitable for 5-axis milling due to the corresponding control technology, extreme feed rates (> 100 m/min) and acceleration values up to 3 g.

In terms of their safety requirements, due to the high speeds, HSC machines demand special measures to protect the operating personnel. High passive safety is achieved by the corresponding design of the work space, which is normally encapsulated. However, for process monitoring, additional attachments also have to be provided to enable the abrupt switching off of the machine in case of imminent breakdown.

Thus, for instance, the firm Hermle integrated a collision protection for the motor spindle, which, in case of collision, axially shifts the milling spindle together with the bearing by maximally 8 mm against so-called upsetting sleeves. Axial stroke is traced/ requested with a pin and a switch. In case of collision, the switch automatically triggers prompt switching off of the control (Maschinenfabrik Berthold Hermle AG, Gosheim).

In the following, typical high speed cutting machines are introduced.

20.3.2.1 High speed machining centre HMC 2500

A high speed machining centre,

bridge machine and Gantry type,

in which not the whole bridge, but only the cross slide performs the longitudinal motion, is illustrated in Figure 20.2.

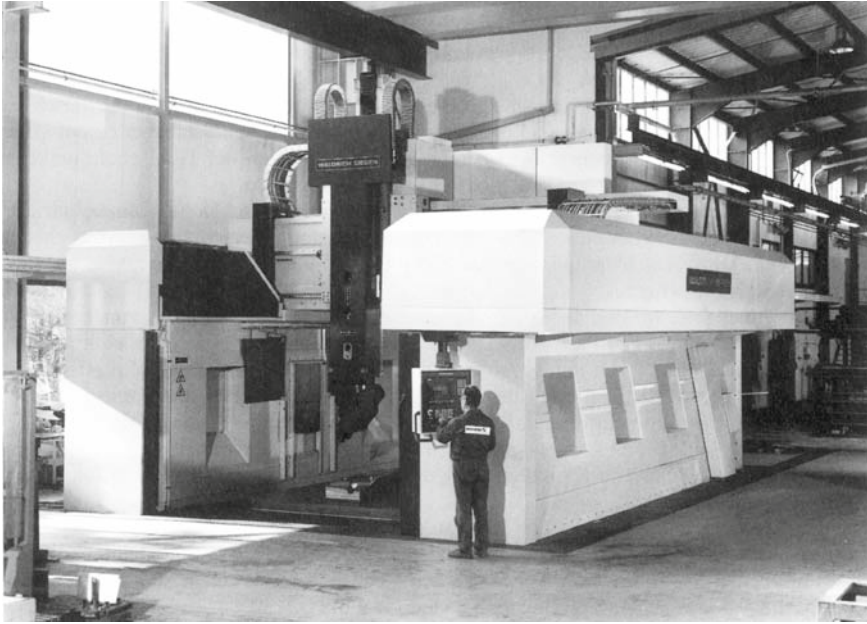


Figure 20.2
High speed machining centre HMC 2500
(photo by Waldrich, Siegen)

The slide rest, fixed on the cross bar, carries out the cross motion.

Because only relatively low loads are travelled in this design, with these machines, one may achieve high rapid traverse- and positioning speeds, which dramatically reduce unproductive idle times.

Rapid rate	15 m/min
Speeding up	2,5 m/s ²

The horizontal spindle unit performs roughing. For finishing, the high speed motor spindle (HF spindle) that can be changed automatically is used.

All guideways in the three axes are designed in a linear guidance system with recirculating, linear roller bearings. Feed motion is realised with preclamped ball screw spindles, in combination with frequency-controlled AC servomotors. The operator centre is fitted with two alternative CNCs (machine controls)

Table 20.3 Technical machine data

Input power	kW	Rpm ⁻¹
Main work spindle	30	7.600
High frequency spindle (HF spindle)	5	2.500 to 35.000
Chucking range	mm	2.500 to 5.000
Travels	mm	
X axis	5.750	
Y axis	2.840	
Z axis	1.500	
Swivelling range	in degree	
C axis	360	
B axis	+ 100	
Minimal increment of B- and C axes	0,001	

- Siemens Sinumerik 840 D
- FIDIA M 20.

The modularly structured tool system may be modified according to the existing machining tasks. The required tools are requested from the tool magazine (chain-like), which is fixed sidewise on the bridge.

The technological data for two workpieces that were produced on this machine are shown in the following.

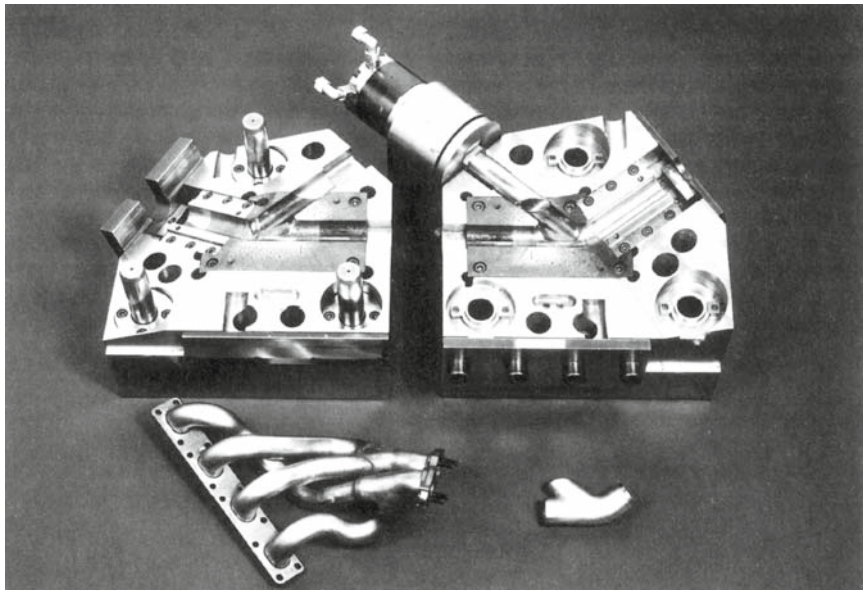


Figure 20.3
Machining of a hydroforming die for exhaust parts.
(photo by Waldrich, Siegen)

Table 20.4 Technological parameters

Test part:	Schuler Hydroforming	Schuler Hydroforming		
Material:	Tool steel	Tool steel		
Operation:	Leveling	Finishing		
Tool:	Solid carbide (VHM) sphere Ø 10	Solid carbide (VHM) sphere Ø 8		
Manufacturer:	Ingersoll	Ingersoll		
Tool-Ø:	10 mm	8 mm		
Mounting:	HSK-E 50	HSK-E 50		
No. of cutting edges:	2	2		
Cutting material:	Uncoated cemented car bide (Ti Al N)	Uncoated cemented car bide (Ti Al N)		
Cutting speed:	v_c : m/min	190	v_c : m/min	220
Rpm:	n : min ⁻¹	6.000	n : min ⁻¹	12.000
Cutting depth:	a_p : mm	0,4	a_p : mm	0,1–0,2
Programmed feed:	v_p : mm/min	3.500	v_p : mm/min	4.500

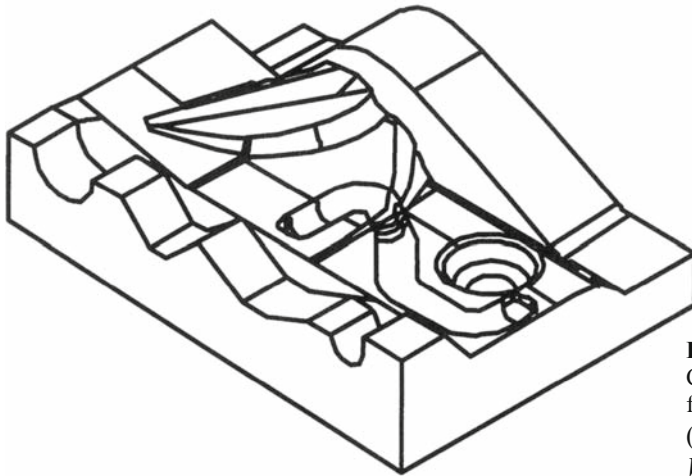


Figure 20.4
Cutting of a test part
for Mercedes
(photo by
Waldrich, Siegen)

20.3.2.2 Hermle C 500 V for tool- and diemaking

The HS-milling machine Hermle C 500 is one of the smallest machines for tool- and diemaking, and it provides the maximal travels for the necessary installation space. The design follows a modified Gantry approach – X- and Y axis in the tool, Z axis in the workpiece – and makes possible a constant ergonomic working height independent of the workpiece height.

Using mineral casting for the machine bed, it is possible to achieve very high attenuation values and very low thermal conductivity (see Figure 20.6). The machine is characterised by proper running-, positioning- and constant accuracy, with short positioning- and preoperation periods, speeding up values of 7 m/s² and rapid rates up to 35 m/min.

Table 20.5 Technological parameters

Test part:	Mercedes-Benz		Mercedes-Benz	
Material:	Aluminium		Aluminium	
Operation:	Levelling		Finishing	
Tool:	Ball headed mill HMK 10 Ø		Ball headed mill HMK 8 Ø	
Manufacturer:	Ingersoll		Ingersoll	
Tool- Ø:	10 mm		8 mm	
Mounting:	HSK-E 50		HSK-E 50	
No. of cutting edges:	2		2	
Cutting material:	Uncoat. cemented carbide (Ti Al N)		Uncoated cemented carbide (Ti Al N)	
Cutting speed.:	v_c : m/min	190	v_c : m/min	220
Rpm:	n : min ⁻¹	6.000	n : min ⁻¹	12.000
Cutting depth:	a_p : mm	0,4	a_p : mm	0,1–0,2
Programmed feed:	v_p : mm/min	10.000	v_p : mm/min	4.500
Mach. Time:	t : min	22		



Figure 20.5
Hermle C 500 V
(photo by CNC-Lab of the HTW Dresden)

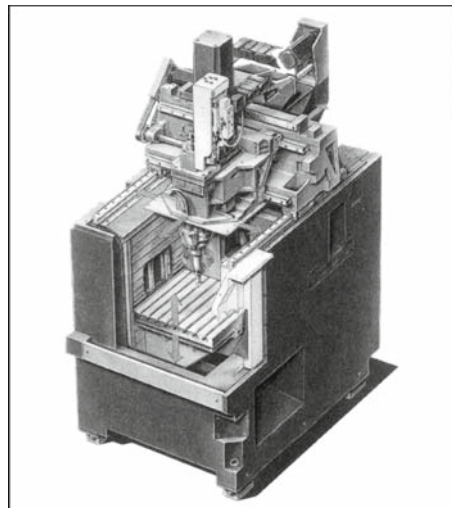


Figure 20.6
Machine bed made as mineral casting
(photo by Hermle AG, Gosheim)

The X slide is embedded as a traverse on three carriages with 2 offset guideways. The guideways in all linear axes are made as profile rail-antifricition guideways. Feed motion is implemented with preclamped ball screws in combination with digital AC servo motors.

Automatic tool change is done in the pick-up mode, and up to 20 tools (HSK 63 A) are stored (located) in the disk magazine, thus enabling a chip-to-chip time of 5 s.

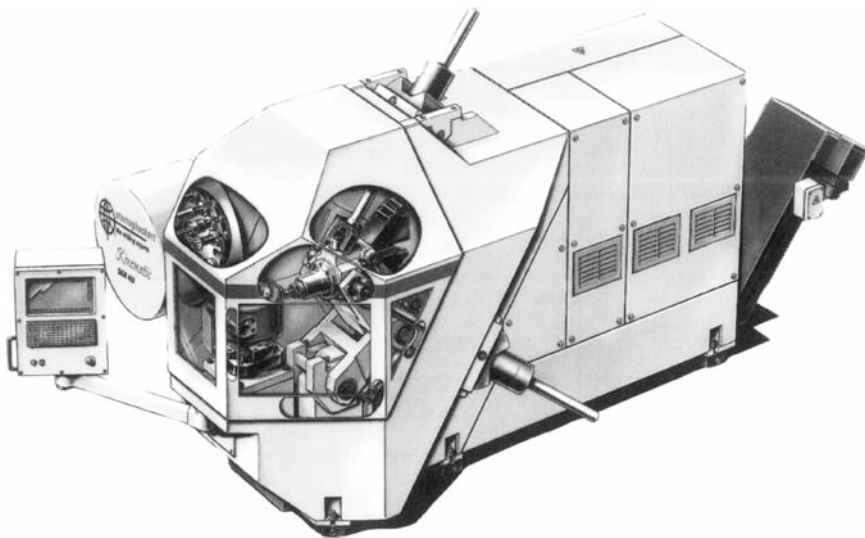
Programming of the CNC Heidenhain TNC 426 can be performed in dialogue or according to DIN/ISO, and thus guarantees demanding milling for tool- and diemaking.

Table 20.6 Technical machine data

Input power of motor spindle	Kw	16 (40% ED)
Torque	Nm	53 (40% ED)
Speed range (rpm)	min ⁻¹	50 ... 16.000
Tool mounting		HSK-A 63
Chucking area	mm × mm	540 × 560
Travels of the work spindle	Mm	X = 500, Y = 400, Z = 450
Traversing speeds	m/min (rapid traverse)	35 (X and Y)
	m/min (rapid traverse)	30 (Z)
	m/s ² (speeding up)	7

20.3.2.3 Kinematic SKM 400

The Heckert company designed and launched on the market the SKM 400, a pioneering application of parallel kinematic mechanisms (tripod) for highly dynamic machining of box-like workpieces made of light metal and steel, maximum side length 600 mm (Figure 20.7).

**Figure 20.7**

SKM 400 – total view

(photo by Heckert Werkzeugmaschinen GmbH, Chemnitz)

The patented tripod design means that the work spindle is always moved horizontally in space due to the coupled kinematic mechanism.

All translational motions in the axes – longitudinally, cross and orthogonally – are carried out only by the work spindle with the tool. Thus, a wide variety of designs and types are possible for the workpiece side (rotary-, swivelling table etc.) (see Figure 20.8).

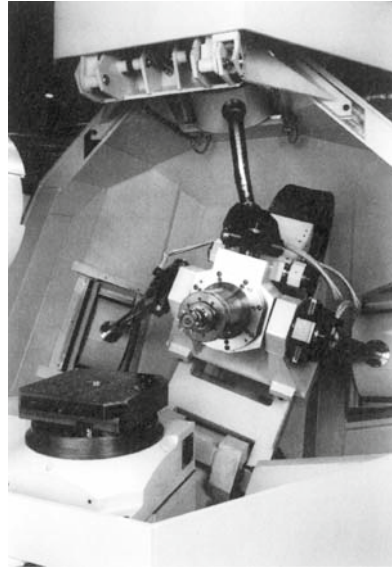


Figure 20.8
Working area of the SKM 400
(photo by Heckert Werkzeugmaschinen GmbH,
Chemnitz)

The present assemblies, such as column, bed, slide, slide rest and guideways, become totally unnecessary, in other words: Better dynamical characteristics, higher stiffness and a significant decrease of costs are achieved with fewer assemblies.

The machine is characterised by improved dynamic parameters of the traversing axes with a mean traversing speed of 100 m/min and speed-ups of 10 m/s² due to mass reduction of the assemblies traversed.

Table 20.7 Technical machine data

Input power	kw	31 (40% ED)
Motor spindle		19 (100%ED)
Torque	Nm	200 (40% ED) 165 (100% ED)
Speed range (rpm)	min ⁻¹	50 ... 15.000
Tool mounting		HSK-A63
Chucking area	mm × mm	400 × 400
Travels of the work spindle	mm	X = 650, Y = 650, Z = 650
Traversing speeds	m/min (feed) m/min (rapid traverse) m/s ² (speed up)	0 ... 100 0 ... 100 10
NC rotary table	Input accuracy in ° max. load (kg) Diameter interference area (mm)	0,001 1.000 700

20.3.3 Tools for high speed milling

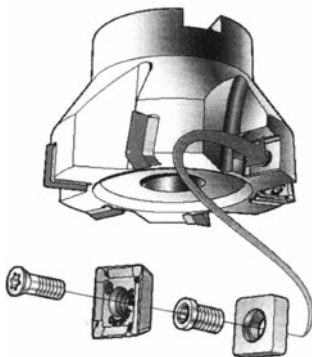
High speed cutting demands special qualifications both in the cutting material and tool design and -dimensioning. As a matter of fact, the selection of the adequate cutting material for high speed machining depends most of all on the material. Thus, the use of PCD and diamond coated cemented carbide is standard for aluminium machining. For the machining of cast iron and partially also hardened steels, CBN cutting material is used, but so are newer developments in fine grain- and superfine grain cemented carbides and cermets, each with the appropriate coatings, as well as highly heat resistant whisker-reinforced ceramic cutting materials.

Concerning tool design, in HSC, the following two issues are crucial:

- Tool imbalance,
- Acceptable centrifugal forces.

According to investigations by the firm Sandvik, Dr. K. Christoffel, Sandvik GmbH, Düsseldorf, tool imbalances may generate forces at high speeds that exceed the cutting forces of the cutting procedure. However, definite consequences can only be found out at very high imbalance values. The expected negative effect on tool life and the load of the spindle bearing has to be considered when specifying the imbalance quality levels.

Milling cutters for HSC, which are increasingly also used as tools with indexable inserts, have to be designed in such a way that the tool body or the chucking elements do not break even at speeds in the upper range of the speed limit. Consequently, newly developed mills for high speed cutting are tested on centrifugal test benches. Figure 20.9 demonstrates a face and shoulder mill with indexable inserts. For this tool, the permissible cutting speed according to the standard draft “Milling cutters for machining with increased peripheral speed – requirements concerning safety regulations” was ascertained by centrifugal test. The permissible rpm/cutting speed is determined at a safety factor 2 from the breakdown rpm.



Diameter	Breakdown rpm	Permissible rpm	Permissible v_c
mm	min^{-1}	min^{-1}	m/min
50	49.900	24.950	3.919
125	30.200	15.100	5.925

Figure 20.9

Permissible cutting speeds for a mill with indexable inserts (Face and shoulder mill CoroMill R 290.90) (Dr. K. Christoffel, Sandvik GmbH, Düsseldorf)

During all centrifugal tests, the fracture of a clamp screw for an indexable insert was the reason for breakdown. However, according to the assessment by the tool manufacturer, this is considered less dangerous than the tool body bursting. In any case, the passive safety of the HSC machines (encapsulation, safety glass etc.) should be high, since operating errors may also result in tool fracture, too.

One must also ensure that the data on permissible speeds are only related to the corresponding tool. Mounting in the machine spindle, which in HSC machines is generally implemented with hollow shaft short tapers (German abbrev.: HSK) according to DIN 69893 and is characterised by good running- and exchange accuracy as well as by amplification of the clamping force under the influence of the centrifugal force, has to be considered, as well as the mountings, adapters or possible tool extensions, and their type of clamping (shrinking chuck, hydraulic expansion chuck etc.) and connection have to be considered. It might be the case that the applied assemblies and components reduce permissible rpm.

Figure 20.10 shows force chucks to mount end mills for high speed machining in tool- and diemaking.

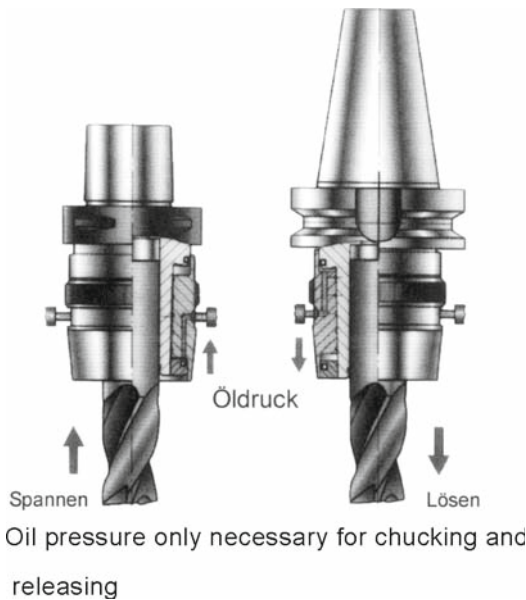


Figure 20.10
Coro-Grip precision power chuck
(photo by Sandvik, Düsseldorf)

Tab. 20.8 Torque transformation in different holder systems – comparison

Shank diameter	Torque	Holder
mm	Nm	
12	93	CoroGrip Shrinking holder Moving chuck
	72	
	50	
20	440	CoroGrip Shrinking holder Moving chuck
	243	
	181	
25	804	CoroGrip Shrinking holder Moving chuck
	421	
	365	
32	1512	CoroGrip Shrinking holder Moving chuck
	–	
	651	

Corogrip – finely balanced for high speed machining, up to 40.000 rev/min for small holder sizes

One may see the machines shown in this chapter in operation on the attached CD-ROM. For milling of large moulds, e.g. embossing dies for the automotive industry (see Figures 20.3 and 20.4), inserted tooth cutters (milling cutter heads) with indexable inserts are used for roughing.

To generate profile contours, one uses form-relieved cutters, such as ball headed mills or torus milling cutters.

This profiling attachment is preferred for applying prefinishing and finishing.

The ball headed mill (Figure 20.11) is equipped with circular cemented carbide plates made of fine grain cemented carbide, PVD coated (TiAlN).



Figure 20.11
Ball headed mill type M27
(photo by Widiafabrik, Essen)

The torus milling cutter is a solid carbide mill made of coated fine grain cemented carbide, coated with TiAlN. This mill has a spiral flute at 30° and has 2 or 4 cutting edges. The mill diameters commonly used range from 2 to 20 mm.



Figure 20.12
Torus milling cutter
(photo Widiafabrik, Essen)

Tools for high speed thread milling

For the efficient manufacturing of internal threads in the high speed region, that means also for hard machining, innovative solid carbide circular thrillers are available (see Figure 20.13).

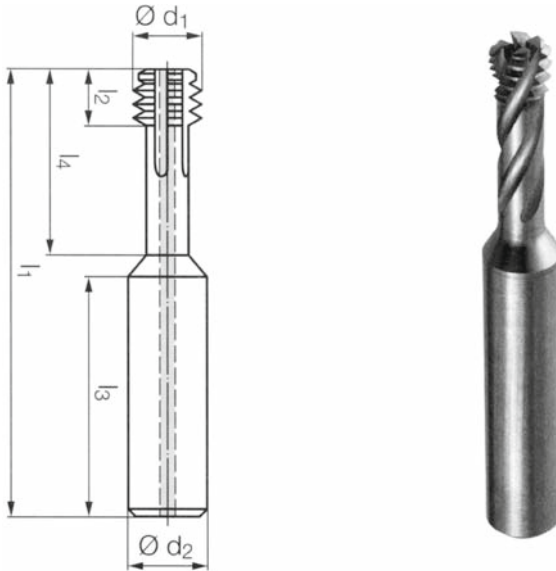


Figure 20.13

Solid carbide circular thriller type H (ZBGF-H)

(courtesy of EMUGE-Werk Richard Glimpel GmbH & Co. KG, Lauf)

These high performance tools with internal coolant supply are capable of manufacturing the core hole and the thread in one operation through a circular milling operation.

The following performance features are provided:

- Short process periods due to high speed machining;
- No exchange times, since chamfering, drilling and thread milling are carried out with one tool;
- Hard machining up to 60 HRC.

Whereas thread milling is also applicable on conventional milling machines, circular-thread milling necessitates use of a powerful CNC milling machine being able to perform a 3-D spiral (helical) interpolation. Due to the internal coolant supply (20 bar), which, as a rule, is available on advanced HS milling machines, sufficient cooling of the cutting edge region and chip transport are possible.

The circular thrilling principle is explained in Figure 20.14, and the attached CD-ROM represents the functionality.

The thread is produced in the following 6 steps:

1. Position milling cutter in rapid traverse over the hole centre
2. Radial travelling on thread diameter
3. Lowering and circular thrilling to a depth of $1 \times \text{pitch}$
4. Circular thrilling to a depth (depending on each milling cutter) $n \times \text{pitch}$
5. Radial travelling on hole centre
6. Travel tool in rapid traverse on safety distance

Thus savings of up to 50 % in comparison with conventional manufacturing of internal threads are feasible.

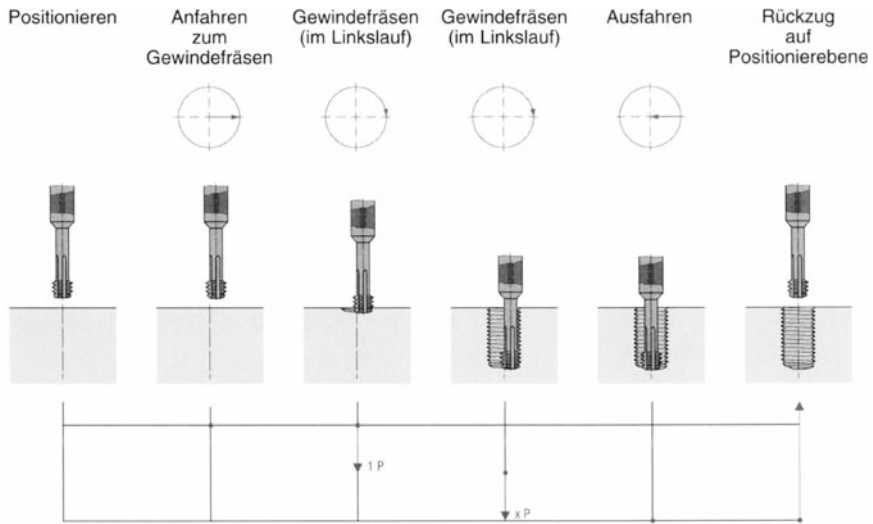


Figure 20.14

Circular thrilling – principle

(Courtesy of EMUGE-Werk Richard Glimpel GmbH & Co. KG, Lauf)

To program the CNC machine, cycles are available both for thrilling and circular-thrilling (for example, for Heidenhain TNC 426).

The cutting values for thrilling with solid carbide tools are summarised in the Table below:

	v_c m/min	v_c m/min	Feed Drilling f_b mm/ rev	Feed Drilling f_b mm/ rev	Feed milling f_z mm/tooth	Feed milling f_z mm/tooth
Ranges of application	Uncoated	TiCN-coated	Mill diameter $d \leq 8$ mm	Mill diameter $d \leq 8$ mm	Mill diameter $d \leq 8$ mm	Mill diameter $d \leq 8$ mm
Cast iron	100–250	150–400	0,15–0,30	0,20–0,40	0,05–0,08	0,07–0,15
aluminium						
Grey cast iron	80–140	100–200	0,1–0,25	0,20–0,40	0,04–0,07	0,05–0,12
Thermosets	60–150	100–400	0,15–0,30	0,20–0,40	0,05–0,10	0,08–0,20

(Courtesy of EMUGE-Werk Richard Glimpel GmbH & Co. KG, Lauf)

20.3.4 Reference cutting parameters for high speed-milling- and - turning

The following reference tables demonstrate the magnitude of cutting speeds, as a function of the material to be machined and the feed rate f_z , in mm/tooth.

However, even today, the cemented carbide manufacturers predict even today, that these values will be increased in the foreseeable future.

Tab. 20.10 Cutting speeds v_s for high speed milling (reference values courtesy of the firm Widiafabrik, Essen)

Operation	Tool	Workpiece material		GE 240		X 155 CrMoV 12.1		C 45 W		X 40 CrMoV 5.1		EN-GJL-250 (GG-25)
		Strength R_m [N/mm ²]	Hardness HB/HRC	1.0443	1.2379	1.2311	1.1730	1.2344	1.100	1500	0.6025	
Copy milling	Mill with circular indexable inserts	Cutting material	60 HRC	200 HB	60 HRC	56 HRC	190 HB	HC-P25	HC-P25	HC-P25	HC-K15	
Roughing	(for example, M100)	Type, for example, Widia	TN7525	TN7525	TN7525	TN7525	TN7525	TN7525	TN7525	TN7525	TN5515	
		v_c [m/min]	250	120	130	130	120	130	120	120	280	
		f_z [mm] at $\varnothing = 50 - 125$ mm	0.26	0.26	0.26	0.26	0.26	0.26	0.26	0.26	0.26	
Copy milling	Ball headed mill (rough cutter)	Cutting material	HC-P35	HC-P35	HC-P35	HC-P35	HC-P35	HC-P35	HC-P35	HC-P35	HW-K15	
Roughing	With indexable inserts, for example M28	Type, for example, Widia	TN7535	TN7535	TN7535	TN7535	TN7535	TN7535	TN7535	TN7535	THM	
		v_c [m/min]	180	84	84	84	84	84	84	84	120	
		f_z [mm] at $\varnothing = 25$ mm)	0.18	0.18	0.18	0.18	0.18	0.18	0.18	0.18	0.19	
Rough milling	Shell end mill with indexable inserts	Cutting material	HC-P35	HC-P35	HC-P35	HC-P35	HC-P35	HC-P35	HC-P35	HC-P35	HC-K15	
	(for example M300)	Type, for example, Widia	TN7535	TN7535	TN7535	TN7535	TN7535	TN7535	TN7535	TN7535	TN5515	
		v_c [m/min]	150	70	80	80	80	80	70	70	215	
		f_z [mm] at $\varnothing = 50$ mm ¹⁾	0.19	0.19	0.19	0.19	0.19	0.19	0.19	0.19	0.16	
Copy milling	Ball headed mill-finish cutter	Cutting material	HT-P15	HC-K05	HT-P15	HT-P15	HT-P15	HT-P15	HT-P15	HT-P15	HC-K05	
Finishing	With indexable insert (for example, M27)	Type, for example, Widia	TT125	TN2505	TT125	TT125	TT125	TT125	TT125	TT125	TN2505	
		v_c [m/min]	280	250	300	250	250	250	250	250	280	350
		f_z [mm] at $\varnothing = 10$ mm)	0.12	0.12	0.08	0.12	0.12	0.12	0.12	0.12	0.08	0.01
Copy milling	Torus milling cutter made of solid carbide	Cutting material	HC-K20	HC-K20	HC-K20	HC-K20	HC-K20	HC-K20	HC-K20	HC-K20	HC-K20	
Finishing	(for example, Top Mill S)	v_c [m/min]	160	85	90	80	80	80	85	85	110	120
		f_z [mm] at $\varnothing = 6$ mm)	0.02	0.02	0.02	0.02	0.02	0.02	0.02	0.02	0.02	0.02

¹⁾ Lower diameters cause lower feeds

Tab. 20.11a Cutting speeds v_c for high speed milling (reference values courtesy of the firm Kennametal Hertel GmbH Co. KG Fürth)

Material	Field: milling		Tensile strength R_m (MPa)	Brinell/ Rockwell hardness	KC-930M HM-CVD HC-P30 M30-K25 v_c (m/min)	KY3500 Ceramic CN-K20 v_c (m/min)	KY4300 Ceramic CM-M15 CM-K10 v_c (m/min)	KT530M HM-PVD HT-P25 HT-M25 v_c (m/min)	KD1410 PKD DP-K10 v_c (m/min)
	Structure								
Unalloyed steel	C = 0,10 % – 0,25 %		420	125	240 – 280			260 – 300	
	C = 0,25 % – 0,55 %		–	250	190 – 230			240 – 280	
	C = 0,55 % – 0,80 %		1020	300	190 – 230			220 – 260	
Low alloy steel			610	180	140 – 180			200 – 240	
			–	275	130 – 170			180 – 220	
High alloy steel			1190	350	130 – 170			150 – 190	
	Ferritic/martensitic		680	200	130 – 170			150 – 190	
	Martensitic		1100	325	210 – 250			150 – 190	
High grade steel	Austenitic		680	200	150 – 190			230 – 270	
	Austenitic/ferritic		810	240	120 – 160			200 – 240	
Stainless steel	Austenitic		610	180	130 – 170			210 – 250	
	Austenitic/ferritic		880	260	130 – 170			180 – 220	
Cast iron	Perlitic/ferritic		180	180	180 – 220	700 – 900			
	Perlitic/martensitic		260	260	160 – 200	500 – 700			
Aluminium alloys	< 12 % Si, not to be aged		75	75					
	> 12 % Si, not to be aged		130	130					3500 – 4500
Copper and its alloys	Pb > 1 %		110	110					
	CuZn, CuSnZn		90	90					
Non-ferrous metals	Cu, not with lead + Electric		100	100					
	Composites								
Titanium and its alloys	Pure titanium		400						
	Alpha-beta alloy		1050						
Hardened steel and white cast iron				45–63 HRC					
								95 – 135	
								95 – 135	

Tab. 20.11b Cutting speeds v_c for high speed milling (reference values courtesy of the firm Kennametal Hertel GmbH Co. KG Fürth)

Material	Technology: milling		Tensile strength	Brinell/ Rockwell hardness	K110M HM-unb. HW-M10- HW-K10	K125M HM-unb. HW-P25	KC510M HM-PVD HC-M15 HC-K10	KC520M HM-PVD HC-K20	KC525M HM-PVD HC-P25 M30-K25
	Structure	R_m (MPa)							
Unalloyed steel	C = 0,10 % - 0,25 %	420	125		v_c (m/min)	140 - 180		v_c (m/min)	270 - 310
	C = 0,25 % - 0,55 %	—	250			100 - 160			220 - 260
	C = 0,55 % - 0,80 %	1020	300			70 - 120			220 - 260
Low alloy steel		610	180			70 - 110			160 - 200
		1190	350			60 - 100			150 - 190
High alloy steel	Ferritic/martensitic	680	200			80 - 120			150 - 190
	Martensitic	1100	325			80 - 120			240 - 280
High grade steel	Austenitic	680	200						180 - 220
	Austenitic/ferritic	810	240						140 - 180
Stainless steel	Austenitic	610	180						150 - 190
	Austenitic/ferritic	880	260						150 - 190
Cast iron	Perlitic/ferritic	180	180		80 - 120				
	Perlitic/martensitic	260	260		60 - 100				
Aluminium alloys	< 12 % Si, not to be aged	75	75		400 - 800			900 - 1200	
	> 12 % Si, not to be aged	130	130					350 - 450	
Copper and its alloys	Pb > 1 %	110	110		250 - 350			450 - 550	
	CuZn, CuSnZn	90	90		250 - 350			550 - 650	
Non-ferrous metals	Cu, not with lead + Electric	100	100		250 - 350			600 - 700	
	Composites	400	400		250 - 350			600 - 700	
Titanium and its alloys	Pure titanium	1050	1050		25 - 35			80 - 100	90 - 110
	Alpha-beta alloy				30 - 40			50 - 70	60 - 80
Hardened steel and white cast iron			45 - 63 HRC						

Tab. 20.12 Recommended cutting values for high speed slab milling (reference values courtesy of the firm Kennametal Hertel GmbH Co. KG, Fürth)

Material	HW-K10 K110M	HC-K10 KC520M	HC-K20 KC920M	HC-P15 KC715M	HC-M30 KC725M	CN-K20 KY3500	DP-K15 KD1415	BN-K40 KB 1340
C45 1.1191				$v_c = 450$ m/min $f_z = 0,25$ mm	$v_c = 400$ m/min $f_z = 0,22$ mm			
16MnCr5 1.7131				$v_c = 400$ m/min $f_z = 0,2$ mm	$v_c = 350$ m/min $f_z = 0,18$ mm			
42CrMo4V 1.7225				$v_c = 300$ m/min $f_z = 0,25$ mm	$v_c = 270$ m/min $f_z = 0,22$ mm			
X40CrMoV51 1.2344				$v_c = 200$ m/min $f_z = 0,2$ mm	$v_c = 250$ m/min $f_z = 0,2$ mm			
X5CrNi1810 1.4301					$v_c = 200$ m/min $f_z = 0,15$ mm			
GJL 250 0.6025	$v_c = 120$ m/min $f_z = 0,25$ mm	$v_c = 280$ m/min $f_z = 0,25$ mm	$v_c = 400$ m/min $f_z = 0,2$ mm			$v_c = 1000$ m/min $f_z = 0,2$ mm		$v_c = 1000$ m/min $f_z = 0,3$ mm $a_p = 0,5$ mm*
GJS-600-15 JS 1060		$v_c = 190$ m/min $f_z = 0,2$ mm	$v_c = 250$ m/min $f_z = 0,2$ mm					
AC AISI9Cu1	$v_c = 800$ m/min $f_z = 0,3$ mm	$v_c = 2000$ m/min $f_z = 0,25$ mm					$v_c = 6000$ m/min $f_z = 0,2$ mm	

Slab milling $a_p = 3$ mm

- Tool diameter $D_c = 100$ mm
- Width of cut $65^\circ - 70^\circ$ von D_c
- Stable conditions

21 Cutting fluids (coolants and lubricants)

21.1 Introduction

The energy used in the cutting process is almost exclusively transformed into heat, which means, depending on the method, that this thermal energy appears in the workpiece, the chip and the tool to different extents. During high speed milling, as explained in Chapter 20, it is possible to discharge the energy almost completely with the chip.

In planning cutting processes, it is essential that this thermal energy have either just a slight negative impact on the workpiece, the tool and the machine tool or no negative impact at all. Consequently, during cutting, the coolants and lubricants have to fulfil the following tasks:

- Diminish tool wear (longer tool life),
- Produce workpieces of accurate size (reduce thermal expansion),
- Achieve proper surface quality of the workpieces,
- Support chip removal,
- Reduce thermal stress on machine tool.

In recent years, the drastic increase in costs for use, separation and disposal of the cutting fluids in combination with new legislation on environmental- and health protection, which is expected to become even more stringent in the future, have led to comprehensive scientific research and initial practical results.

In this context, dry machining, which has become possible in conjunction with high speed cutting, offers the greatest effects, on the one hand. On the other hand, problems with tool wear and heat generation on and inside the workpiece and tool are not unimportant. As an alternative to the conventional use of cutting fluids and dry machining, minimum quantity lubrication (MQL) provides a solution. This results in the following classification of lubricant applications:

Tab. 21.1 Classification of lubricant types

Lubrication type	Content	Used volume
Wet machining (using coolant)	Flooding supply, full jet lubrication	10 to 100 l/min
Reduced lubrication	Minimum quantity lubrication (MQL)	50 ml/h up to 1–2 l/h
	Minimum quantity cooling lubrication (German abbrev: MMKS)	< 50 ml/h
Without lubrication	Dry machining	without

21.2 Wet cutting

As a result of the higher specific thermal capacity and also higher thermal conductivity of water versus mineral oil, water has a better cooling performance. However, mineral oil and the corresponding additives are much better at reducing friction.

Depending on the cutting technique (for instance, grinding; see Chapter 13, Tab. 13.24), we can find both full jet lubrication with non-water-miscible cutting fluid (based on mineral oil of suitable viscosity) and water cooling (with anticorrosive additives). However, the emulsions, which are a mix of water-miscible mineral oils and water, are the most frequently used cutting fluids. Mineral oils are used only approximately 5% to 7% of the time.

With the help of additives, the cutting fluids should have the following additional qualities:

- Physiological harmlessness for the operating personnel,
- Environmental compatibility and biodegradability,
- Corrosion protection of workpiece and machine,
- Formation of the lubricant film,
- Ability to be flooded and wetted (reducing the liquid's surface tension),
- Resistance to microorganisms,
- Resistance to paints and varnishes,
- Filterability.

The selection of a suitable cutting fluid is done not only according to the manufacturing task, if necessary according to the regulations by the machine manufacturer, but also to criteria like lubricant systems used by the firm, price, shelf life, compatibility with other oils used on the machine, disposal costs and last, but not least, physiological harmlessness (DIN Safety data sheet for the cutting fluid, as well, if necessary, as expert reports on effects on skin) have to be considered.

During use, cutting fluids are subject to constant alterations and influences and have to be checked and maintained regularly. Microorganisms, such as bacteria, fungi or yeasts, may negatively affect emulsions. For this reason, the entire lubricating system of the machine tool has to be thoroughly cleaned and flushed from time to time before a new emulsion may be added.

21.3 Minimum quantity cooling lubrication (MQL)

In recent years, minimum volume cutting fluid supply was created as an alternative to the conventional full jet lubrication for some cutting techniques. An effective cooling and lubricating effect is achieved at the contact position thanks to very fine distribution of a low quantity (approx. 20 ml per working hour) of an air-oil mix at the point of contact between tool and workpiece. However, it is impossible this way to sufficiently reduce the thermal impacts on the machine. Accordingly, minimum quantity cooling lubrication (minimum quantity of lubricants; MQL) combines the advantages of dry machining (reduction of cutting fluid- and disposal costs, cleanness of machine etc.) with a proper lubricating- and cooling effect on the work area. In many cases, this method is called near-dry cutting, since the workpiece and the chips are as dry as possible after the cutting process. Also, recycling biologically degradable lubricant may result in a tremendous reduction in the costs of the lubricant and disposal. Depending on cutting technology, machine tool type and tool, the user has available different minimum quantity lubrication systems for retrofitting. Advanced machines

are already optionally equipped by the manufacturer with minimum quantity lubrication systems. The major difference from conventional circulating cooling lubrication is the variety of systems for the cutting fluid transport. Vacuum-, excess pressure- and dosing pump systems are all in use (see Table). As a rule, the minimum quantity cutting fluid systems (minimum quantity of lubricants – MQL) are run on each machine tool with the available compressed air, and the cutting fluid is partly deposited in drops or as an air-oil mix, continuously or in pulses in the low quantities desired.

Tab. 21.2 Minimum quantity lubrication (MQL) equipment

System	Remarks	Manufacturer (Examples)
Vacuum spray systems	Venturi effect is used	Steidle
Excess pressure spray systems a) Mix is only formed on nozzle b) Mix is formed in the tank	Excess pressure in tank transports the agent	Menzel, MicroJet, Sinis
Reciprocating pump spray system	Transport via pump, pulses	Steidle; WERUCON

The attachment may be switched on manually or triggered by the corresponding machine control (solenoid valve 24V) (see Figure 21.1).

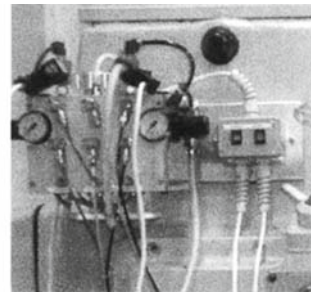
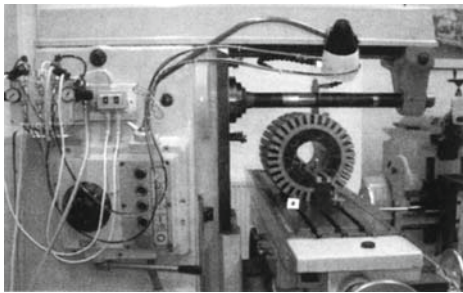


Figure 21.1

Example of an MQL system, added to a milling machine
(photo by the HTW Dresden, Fabricate Menzel)

The advantages of using minimum quantity cooling lubrication systems are known due to investigations done by the automotive industry, among others. According to these studies, the costs of conventional lubricants are already 300 to 400% of the tool costs (see Tab. 21.3).

Tab. 21.3 Benchmark of cutting fluid costs (Courtesy of Heidenreich, DA BMWAG, 2001)

	Firm A	Firm B	Firm C
Workpiece	Al cylinder head	Al cylinder head	Al gear housing
Cutting fluid (German abbrev: KSS)	10% emulsion	7,5% emulsion	10% emulsion
Manufacturing costs	79,2%	82,4%	85,8%
Costs of cutting fluids	16,8%	13,6%	11,8%
Costs for tools	4,0%	4,0%	2,4%

21.4 Dry cutting

Machining without using any cutting fluids at all may result in tremendous economic and environmental benefits. Before cutting without any coolant (dry machining), the functions of the cutting fluids have to be performed by other means. For calculation purposes, the following functional percentage of the cutting fluids is assumed:

- 70% chip transport,
- 20% cooling and
- 10% lubricating.

At present, various research facilities are involved in intensive explorations to determine the development potential of dry machining. In addition to the choice of the adequate cutting parameters as a function of the material to be machined, mainly tool problems (cutting material composition; innovative hard material coatings, modification of the cutting edge geometries etc.) have to be solved before dry machining can be used more widely.

22 Cutting force measurement in machining

22.1 Introduction

New materials are being developed at a rapid pace, and particularly the constant refinement of cutting materials, tools and machine tools calls for up-to-date reference tables for optimal technological values. The tables or recommended data made available by the tool- or material manufacturers are usually very general and do not take into consideration the conditions and experiences of individual production plants. Thus, in many cases, it is useful for users to determine cutting parameters on their own.

One may assess new tools and the machinability of materials with a simple test to measure the cutting forces.

Another essential application for the measurement of cutting forces is focused on monitoring the cutting process to keep the production flow free of disturbances.

Measurement of cutting force components (compare to Chapter 2) with adequate sensors makes it possible to recognise tool breakage and wear early enough that the tool, workpiece and the machine tool can be screened from damages.

The first indirect cutting force measurements were carried out by F.W. Taylor at the beginning of the 19th century. Taylor performed his measurements using the current consumption of the driving motors of the machine tool. Today, in the majority of cutting techniques, much more exact results can be obtained with dynamometers for direct measurement of the cutting force that are based on piezo-quartzes.

The dynamometers for cutting force measurement should have a high static stiffness, high natural frequency and low temperature sensitivity. A suitable allocation (configuration) of the piezo-quartzes compensates for the mutual interaction of the individual components.

Figure 22.1 demonstrates the principle of the structure of a dynamometer that measures the cutting force. The quartz rings that are sensitive to pressure measure the component F_z , while the quartz rings that are sensitive to shear determine the components F_x and F_y .

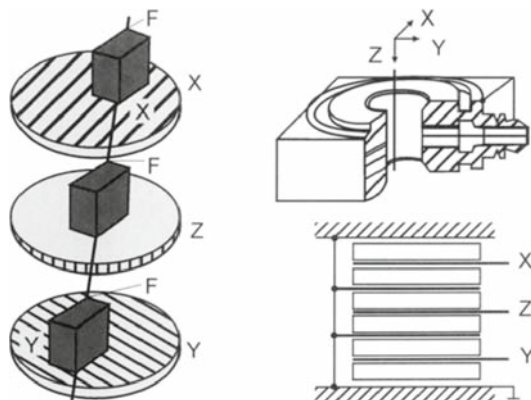


Figure 22.1
View of the principle of a 3-component-dynamometer for cutting force determination (Courtesy of Kistler AG, Winterthur/Switzerland)

22.2 Force measurement during turning

During turning, the three components of the resultant force F_z :

- Cutting force F_c
- Feed force F_f and
- Passive force (displacement force) F_p

are determined by means of the 3-component dynamometer.

The necessary measurement chain is shown in Figure 22.2, wherein the measurement signal of the dynamometer is transformed into a voltage that is proportional to the measured force in the charging amplifier. The force curves can be indicated on an oscilloscope, as well as today on a PC screen, with adequate interfaces.

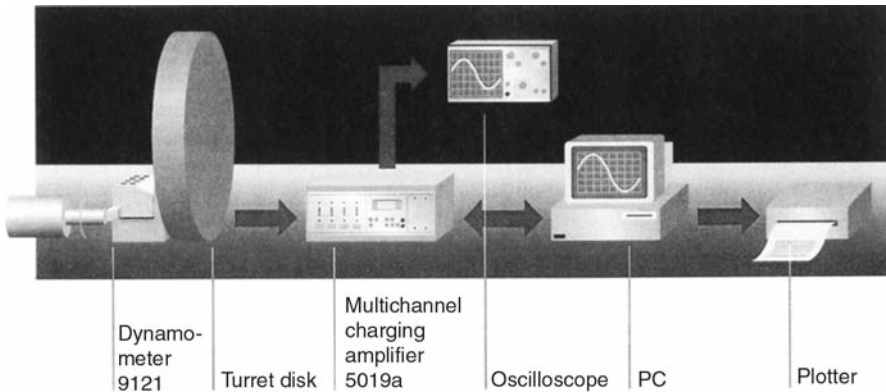


Figure 22.2
Force measurement chain during turning
(Courtesy of Kistler AG, Winterthur/Switzerland)

Figure 22.3 illustrates a 4-component dynamometer of the type 9279 to measure the cutting force, which can be used both during drilling and turning on conventional turning lathes.



Figure 22.3
Test installation for cutting force measurement during turning
(photo by HTW Dresden/Kistler AG)

The forces during machining the steel St 50 with a cemented carbide turning tool were found at the following cutting parameters:

Cutting speed	$v_c = 61$ m/min
Tool cutting edge angle	$k = 45^\circ$ and $k = 70^\circ$
Depth of cut	$a_p = 1,5$ and $2,5$ mm
Feed	$f = 0,112; 0,125; 0,14; 0,18$ mm/rev

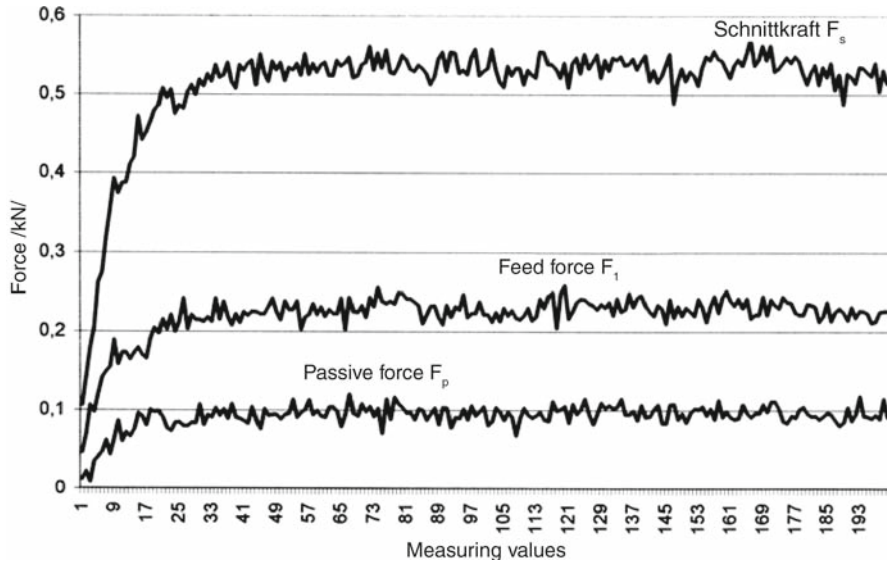


Figure 22.4
Test results for turning $k = 70^\circ$; $a_p = 2,5$ mm; $f = 0,112$ mm/rev)

The test results are demonstrated in Figure 22.4.

The effect of the tool cutting edge angle k on passive- and feed forces, mentioned in Chapter 2, can be clearly seen. The measured and calculated cutting forces differ by less than 10%.

22.3 Force measurement during drilling and milling

During drilling and milling, due to the tool rotation, the cutting force is measured via occurring torque. The principle of the structure of a 4 component dynamometer is shown in Figure 22.5. To determine torque M_z , quartz plates sensitive to shear are allocated in a circle, so that their axes that are sensitive to shear are located tangentially. Feed force F_f is measured with pressure quartz.

The measuring setup for torque- and feed force determination during drilling (into the solid) and boring, making use of a 4-component dynamometer type 9272, can be seen in Figure 22.6. The measurement signal, in turn, is processed with a charging

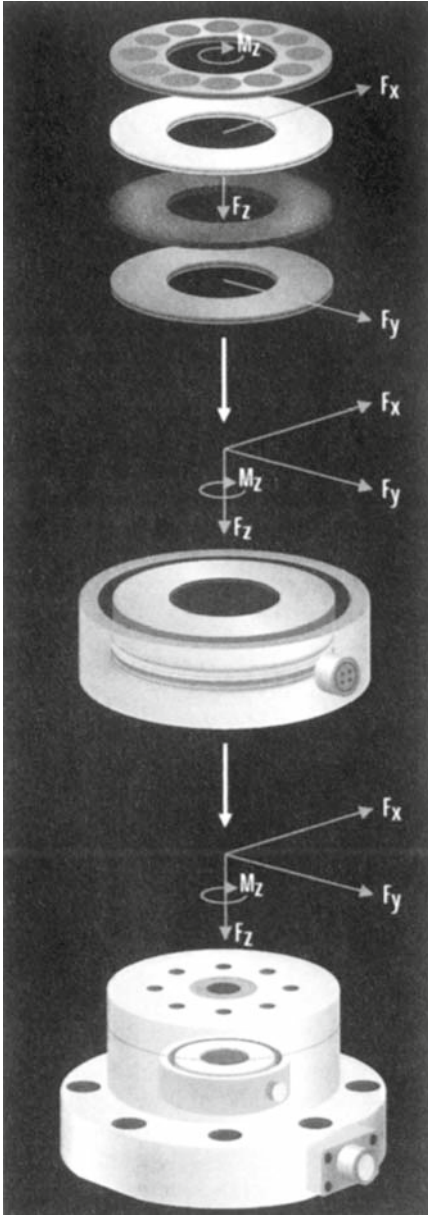


Figure 22.5
Principle of the configuration of
a 4-component dynamometer

amplifier and an analogue-digital converter immediately in the PC and displayed on screen with the software “Testpoint”.

The measurements during cutting of steel St 50 were executed with the following cutting parameters:

Feed $f = 0,15; 0,2; 0,3; 0,36$ mm/rev; $n_c = 900$ min⁻¹; $d = 12$ mm; high-speed steel



Figure 22.6
Experimental setup of force- and torque measurement during drilling
(photo by HTW Dresden, practical cutting course)

The test results are summarised in Figure 22.7.

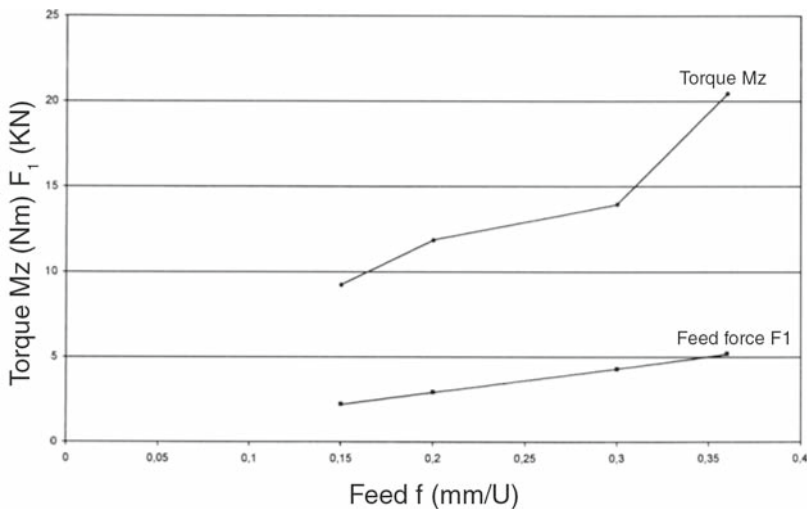


Figure 22.7
Test results during drilling in the solid
(Drill diameter $d = 12$ mm; cutting material: high-speed steel; rpm $n = 900$ min⁻¹)

During milling, as a function of the measuring range, various 3-component dynamometers are used, as well, recently, as rotating cutting force dynamometers (see Figure 22.8), which have been shown to be superior to cutting force measurement based on strain gauges, inductive or capacitive measurement elements. The

rotating cutting force dynamometer consists of a rotor, a stator, connecting cable and signal conditioner. The piezo-electric 2 component sensor (M_z and F_z), 2 charging amplifiers, and the digital transmittal electronics are integrated in the motor. The measurement signals are transmitted to the stator in a contact-less mode.

This dynamometer is also suitable for the investigation of high speed cutting in drilling and milling on the rotating tool, and is also used to monitor the cutting forces in the case of critical tools and expensive workpieces.

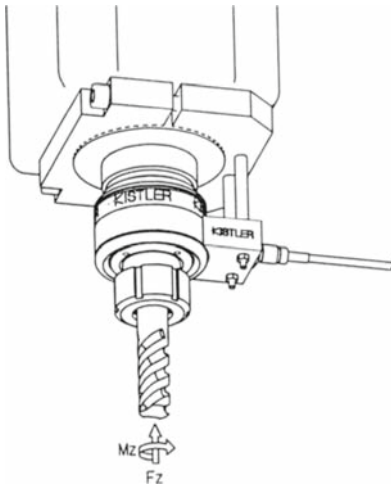


Figure 22.8

22.4 Force measurement during broaching

During broaching, the cutting force is quantified with load cell type U3 (50 kN), based on strain gauges. For a representation of the principle of the measurement chain, see Figure 22.9.

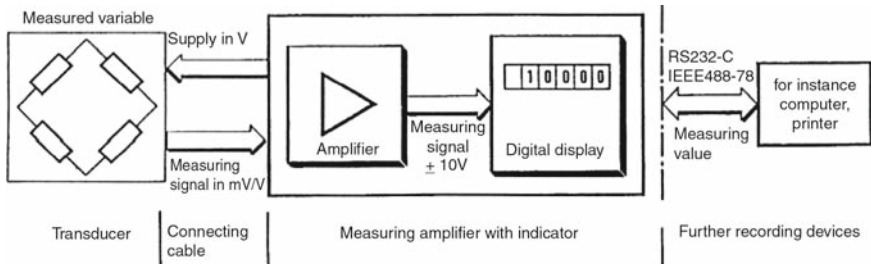


Figure 22.9
Representation of the principle of the measurement chain
(Courtesy of HBM Mess- und Systemtechnik GmbH, Darmstadt)

To record the force trend with respect to motion, an inductive displacement transducer was also attached.

Figure 22.10 elucidates the configuration, and Figure 22.11 and the attached CD-ROM document the test results.

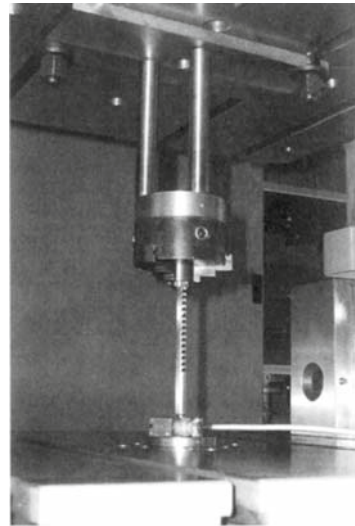


Figure 22.10
Force measurement during broaching (test)
(photo by HTW Dresden, practical cutting course)

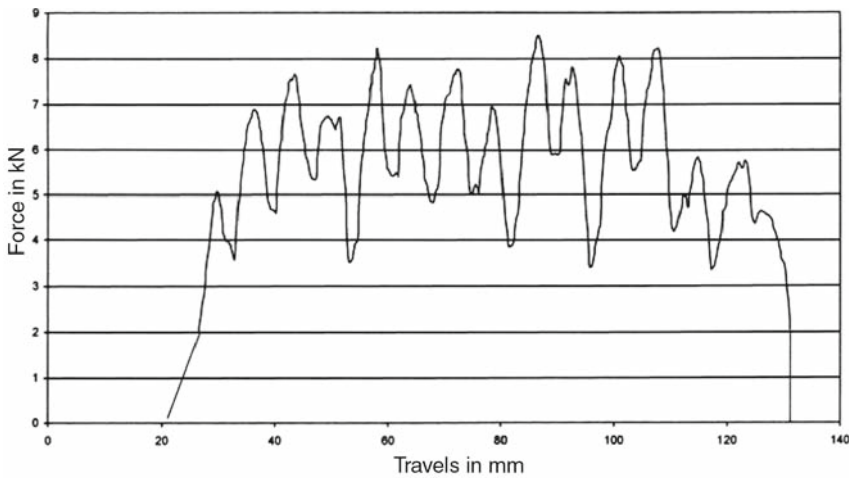


Figure 22.11
Test results gained for broaching
(Broach made of high-speed steel; for a groove width 5 mm; length $l = 170$ mm; internal sleeve diameter $d = 16$ mm; tooth number $z = 16$; broaching depth = 1,4 mm)

23 Tables for general use

Table 23.1 Specific cutting forces

Material	$k_{ct,1}$ in N/mm	z	Specific cutting force k_{ch} in N/mm ² for h in mm						
			0,1	0,16	0,25	0,4	0,63	1,0	1,6
S 235 JR	1780	0,17	2630	2430	2250	2080	1930	1780	1640
E 295	1990	0,26	3620	3210	2850	2530	2250	1990	1760
E 335	2110	0,17	3120	2880	2670	2470	2280	2110	1950
E 360	2260	0,30	4510	3920	3430	2980	2600	2260	1960
C 15	1820	0,22	3020	2720	2470	2230	2020	1820	1640
C 35	1860	0,20	2950	2680	2450	2230	2040	1860	1690
C 45, C 45 E	2220	0,14	3070	2870	2700	2520	2370	2220	2080
C 60 E	2130	0,18	3220	2960	2730	2510	2320	2130	1960
16 MnCr 5	2100	0,26	3820	3380	3010	2660	2370	2100	1860
18 CrNi 6	2260	0,30	4510	3920	3430	2980	2600	2260	1960
34 CrMo 4	2240	0,21	3630	3290	3000	2720	2470	2240	2030
GJL 150	1020	0,25	1810	1610	1440	1280	1150	1020	910
GJL 250	1160	0,26	2110	1870	1660	1470	1310	1160	1030
GE 260	1780	0,17	2630	2430	2250	2080	1930	1780	1640
White cast iron	2060	0,19	3190	2920	2680	2450	2250	2060	1880
Brass	780	0,18	1180	1090	1000	920	850	780	720

Table 23.2 ISO fundamental tolerances, in μm (Excerpt from DIN 7151)

Series of tolerances IT	Nominal dimensions in mm					
	6–10	18–30	30–50	50–80	80–120	180–250
4	4	6	7	8	10	14
5	6	9	11	13	15	20
6	9	13	16	19	22	29
7	15	21	25	30	35	46
8	22	33	39	46	54	72
9	36	52	62	74	87	115
10	58	84	100	120	140	185
11	90	130	160	190	220	290
12	150	210	250	300	350	460
13	220	330	390	460	540	720

The tolerances are based on the international tolerance unit *i*

$$i = 0,45 \cdot \sqrt[3]{D} + 0,001 \cdot D$$

- i* in μm international tolerance unit
- D* in mm geometric average of the nominal dimension ranges
- a, b* in mm nominal dimensions

$$D = \sqrt{a \cdot b}$$

Quality IT	5	6	7	8	9	10	11	12
Tolerance	7 <i>i</i>	10 <i>i</i>	16 <i>i</i>	25 <i>i</i>	40 <i>i</i>	64 <i>i</i>	100 <i>i</i>	160 <i>i</i>

Table 23.3 ISO fits – Basic-hole system – (Excerpt from DIN 7154)

Nominal dimension range above... to mm	Maximum variations in μm (= 0,001 mm)									
	Hole	Shafts								
	H7	s 6	r 3	n 6	m 6	k 6	j 6	h 6	g 6	f 7
from 1 ... 3	+10 0	+20 +14	+16 +10	+10 +4	+8 +2	+6 -0	+4 -2	0 -6	-2 -8	-6 -16
3 ... 6	+12 0	+27 +19	+23 +15	+16 +8	+12 +4	+9 +1	+6 -2	-4 -12	0 -8	-10 -22
6 ... 10	+15 0	+32 +23	+28 +19	+19 +10	+15 +6	+10 +1	+7 -2	0 -9	-5 -14	-13 -28
10 ... 14	+18	+39	+34	+23	+18	+12	+8	0	-6	-16
14 ... 18	0	+28	+23	+12	+7	+1	-3	-11	-17	-34
18 ... 24	+21	+48	+41	+28	+21	+15	+9	0	-7	-20
24 ... 30	0	+35	+28	+15	+8	+2	-4	-13	-20	-41
30 ... 40	+25	+59	+50	+33	+25	+18	+11	0	-9	-25
40 ... 50	0	+43	+34	+17	+9	+2	-5	-16	-25	-50
50 ... 65	+30	+72 +53	+60 +41	+39	+30	+21	+12	0	-10	-30
65 ... 80	0	+78 +59	+62 +43	+20	+11	+2	-7	-19	-29	-60
80 ... 100	+35	+93 +71	+73 +51	+45	+35	+25	+13	0	-12	-36
100 ... 120	0	+101 +79	+76 +54	+23	+13	+3	-9	-22	-34	-71
120 ... 140	+40	+117 +92	+88 +63							
140 ... 160	0	+125 +100	+90 +65	+52 +27	+40 +15	+28 +3	+14 -11	0 -25	-14 -39	-43 -83
160 ... 180	+40	+133 +108	+93 +68							
180 ... 200	+46	+151 +122	+106 +77							
200 ... 225	0	+159 +130	+109 +80	+60 +31	+46 +17	+33 +4	+16 -13	0 -29	15 -44	-50 -96
225 ... 250	+46	+169 +140	+113 +84							
250 ... 280	+52	+190 +158	+126 +94	+66 +34	+52 +20	+36 +4	+16 -16	0 -32	-17 -49	-56 -108
280 ... 315	0	+202 +170	+130 +98							
315 ... 355	+57	+226 +190	+144 +108	+73 +37	+57 +21	+40 +4	+18 -18	0 -36	-18 -54	-62 -119
355 ... 400	0	+244 +208	+150 +114							
400 ... 450	+63	+272 +232	+166 +126	+80 +40	+63 +23	+45 +5	+20 -20	0 -40	-20 -60	-68 -131
450 ... 500	0	+292 +252	+172 +132							
Seat/fit type		Press fit		Tight fit	Driving fit	Adhesive fit	Push fit	Sliding fit	Eng.-running fit	Running fit

Table 23.4 Assignment of machining symbol and peak-to-valley height R_z acc. to DIN 3141 (withdrawn)

Type of machining	Peak-to-valley height R_z in μm			
	Group			
	1	2	3	4
Roughing	160	100	63	25
Finishing	40	25	16	10
Fine finishing	16	6,3	4	2,5
Finest finishing	–	1	1	0,4

Table 23.5 On-load speeds for machine tools (Excerpt from DIN 804)

Nominal values rev/min					
Fundamental series R 20	R 20/2	Derived series			
		R 20/3 (.. 2800 ..)		R20/4 (.. 1400..) (.. 2800 ..)	
$\varphi = 1,12$	$\varphi = 1,25$	$\varphi = 1,4$		$\varphi = 1,6$	$\varphi = 1,6$
1	2	3		4	5
100	112	11,2	125	1400	140
112					
125	140	16	180	2000	224
140					
160					
180	180	22,4	250	2800	280
200					
224					
250					
280	280	31,5	355	4000	355
315					
355					
400					
450					
450	450	45	500	5600	560
500					
560					
630					
710					
800					
900	900	90	1000	8000	900
1000					

Table 23.6 Acceptable variations for dimensions without tolerance (Excerpt from DIN 7168)

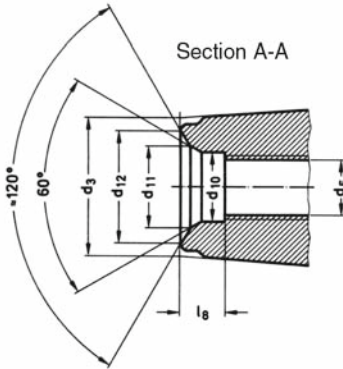
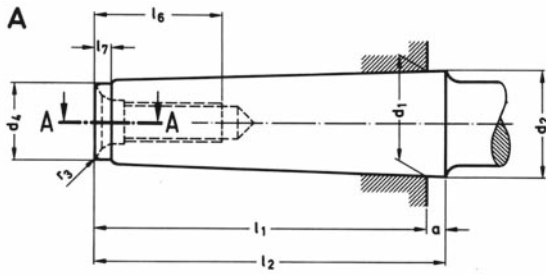
Degree of accuracy	Numerical values for linear measures in mm							
	Nominal dimension range							
	above 0,5 to 3	above 3 to 6	above 6 to 30	above 30 to 120	above 120 to 315	above 315 to 1000	above 1000 to 2000	above 2000 to 4000
Fine	± 0,05	± 0,05	± 0,1	± 0,15	± 0,2	± 0,3	± 0,5	± 0,8
Medium	± 0,1	± 0,1	± 0,2	± 0,3	± 0,5	± 0,8	± 1,2	± 2
Coarse	—	± 0,2	± 0,5	± 0,8	± 1,2	± 2	± 3	± 4
Very coarse	—	± 0,5	± 1	± 1,5	± 2	± 3	± 4	± 6

Table 23.7a Tool taper (Excerpt from DIN 228), all dimensions in mm

	d_1	d_2	d_3	d_5	d_6	d_7	d_4	l_1	l_2	l_3	l_4
Morse taper 0	9,045	9,212	6,453	—	6,1	6,0	6,0	49,8	53,0	56,5	59,5
1	12,065	12,240	9,396	M 6	9,0	8,7	9,0	53,5	57,0	62	65,5
2	17,780	17,980	14,583	M 10	14,0	13,5	14,0	64,0	69,0	75	80
3	23,825	24,051	19,784	M 12	19,1	18,5	19,0	81,0	86,0	94	99
4	31,267	31,543	25,933	M 16	25,2	24,5	25,0	102,5	109,0	117,5	124
5	44,399	44,731	37,574	M 20	36,5	36,0	36,0	129,5	136,0	149,5	156
6	63,348	53,905	53,905	M 24	52,4	51,0	51,0	182,0	190,0	210	218

	a Max. size	b h_{13}	l_5	l_6 Min. size	r_1	r_2	r_3	l_8	l_7	d_{10}	d_{11}	d_{12}	Taper
Morse taper 0	3	3,9	10,5	—	4	1	0,2	—	2,5	—	—	—	1:19,212 = 0,05205
1	3,5	5,2	13,5	16	5	1,2	0,2	4	3	6,4	8	8,5	1:20,047 = 0,04988
2	5	6,3	16	24	6	1,6	0,2	5	4	10,5	12,5	13,2	1:20,020 = 0,04995
3	5	7,9	20	28	7	2	0,5	6	4	13	15	17	1:19,922 = 0,05020
4	6,5	11,9	24	32	8	2,5	1	8	5	17	20	22	1:19,254 = 0,05194
5	6,5	15,9	30	40	11	3	2,5	11	6	21	26	30	1:19,002 = 0,05263
6	8	19	44	50	17	4	4	12	7	25	31	36	1:19,180 = 0,05214

A Taper shank with tapped end



B Taper shank with tang

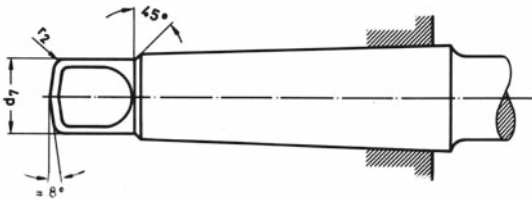
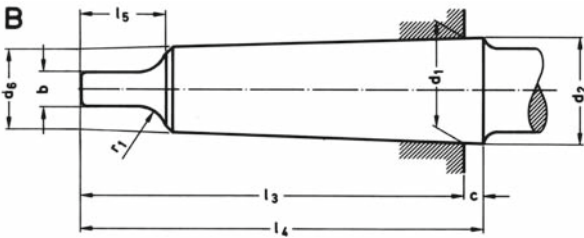


Table 23.7b Tool taper (excerpt from DIN 228), all dimensions in mm
 C Taper sleeves (1 for shanks with tang, 2 for taper shanks with tapped end)

Name of dimension		D	d_6	d_7 Min. size	l_5	l_6	l_7	C A 13	l_{13}
Metric taper	4	4	3	—	25	21	20	2,2	8
	6	6	4,6	—	34	29	28	3,2	12
Morse taper	0	9,045	6,7	—	52	49	45	3,9	15
	1	12,065	9,7	7	56	52	47	5,2	19
	2	17,780	14,9	11,5	67	63	58	6,3	22
	3	23,825	20,2	14	84	78	72	7,9	27
	4	31,267	26,5	18	107	98	92	11,9	32
	5	44,399	38,2	23	135	125	118	15,9	38
Metric taper	80	80	71,4	33	202	186	172	26	52
	100	100	89,9	39	240	220	202	32	60
	120	120	108,4	39	276	254	232	38	68
	(140)	140	126,9	39	312	286	262	44	76
	160	160	145,4	52	350	321	292	50	84
	(180)	180	163,9	52	388	355	332	56	92
	200	200	182,4	52	424	388	352	62	100

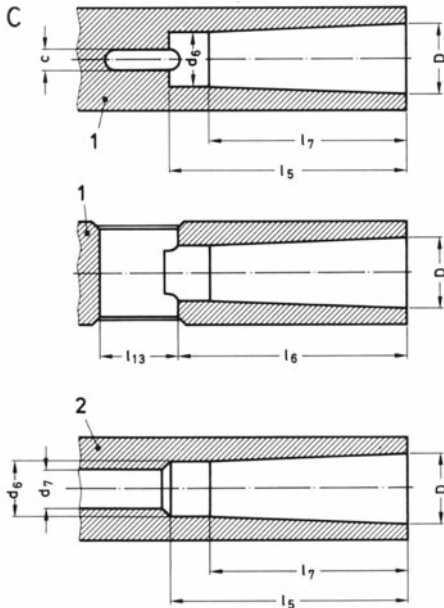
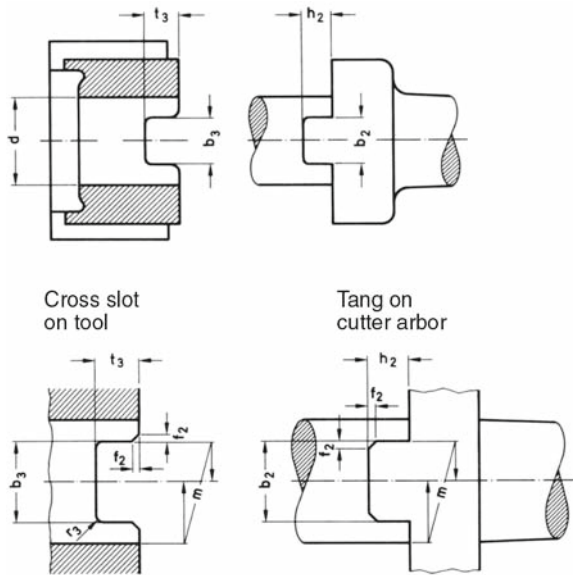


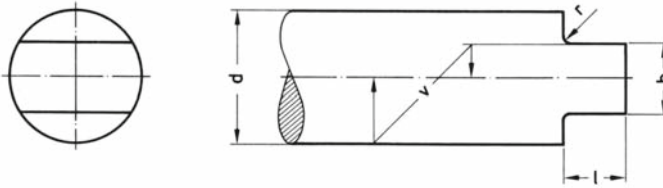
Table 23.8 Hole, grooves and carrier for milling cutters (Excerpt from DIN 138)



Design need not follow the representation; only the given dimensions must be maintained, all sizes in mm.

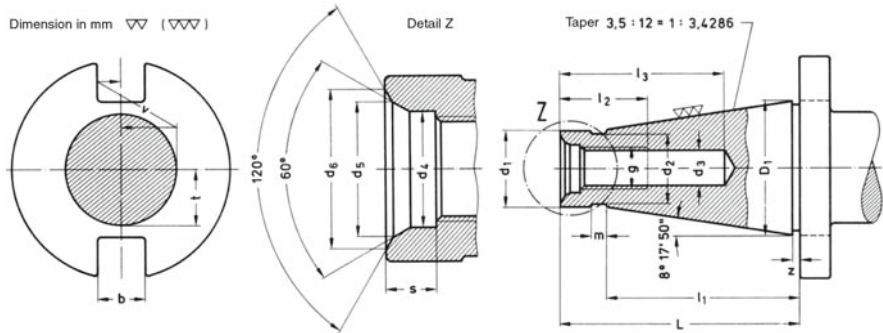
Hole d H 7	b_2 h 11	b_3 H 11	h_2 h 11	t_3 H 12	r_3 Acc. deviat.	f_2		m in μm Acceptable eccentricity of tang and cross groove	
							Acc. deviat.		
8	5	5,4	3,5	4	0,6	0,4	+ 0,1	100	
10	6	6,4	4	4,5	0,8				- 0,2
a13	8	8,4	4,5	5	1	- 0,3	+ 0,2		
16	8	8,4	5	5,6	1,2				0,6
22	10	10,4	5,6	6,3					
27	12	12,4	6,3	7	- 0,4	1	+ 0,3		
32	14	14,4	7	8					2
40	16	16,4	8	9	2,5	1,6	+ 0,5		
50	18	18,4	9	10					3
60	20	20,5	10	11,2	3	1,6	+ 0,5		
70	22	22,5	11,2	12,5				3	1,6
80	24	24,5	12,5	14	3	1,6	+ 0,5		
100	24	24,5	14	16				3	1,6

Table 23.9 Carrier on tools with parallel shank (excerpt from DIN 1809), all dimensions in mm



Diameter range <i>d</i>	<i>b</i> h 12	<i>l</i> ± IT 16	<i>r</i>	<i>v</i>
3–6,5	1,6–3	2,2–3	0,2	0,05
above 6,5 to 8	3,5	3,5	0,2	0,06
above 8 to 9,5	4,5	4,5	0,4	
above 9,5 to 11	5	5	0,4	
above 11 to 13	6	6	0,4	
above 13 to 15	7	7	0,4	0,03
above 15 to 18	8	8	0,4	
above 18 to 21	10	10	0,4	
above 21 to 24	11	11	0,6	0,10
above 24 to 27	13	13	0,6	
above 27 to 30	14	14	0,6	
above 30 to 34	16	16	0,6	
38–50	18–24	18–22	1	0,15

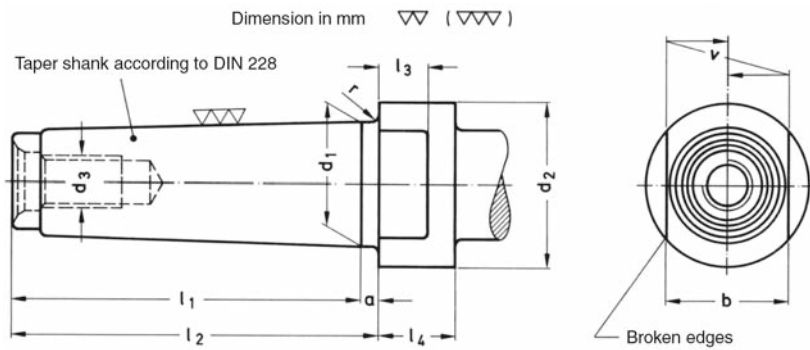
Table 23.10 Tool shanks with steep taper and thread (DIN 2080), all dimensions in mm



Steep taper Nr	Taper shank and pilot pin							Carrier slots			
	D_1	d_1	d_2	L Max. size	l_1	m	z $\pm 0,4$	b $+ 0,25$	t Max. size	v	
30	31,75	17,4	16,5	70	50	3	1,6	16	16	0,03	
40	44,45	25,3	24	95	67	5	1,6	16	22,5	0,03	
50	69,85	39,6	38	130	105	8	3,2	25,6	35	0,04	
60	107,95	60,2	58	210	165	10	3,2	25,6	60	0,04	

Steep taper No.	Hole									
	g		d_3		d_4	d_5 Max. size	d_6 Max. size	l_2	l_3	s
	Metric	Inch	for metr. thread	for inch measure screw thread						
30	M 12	1/2-13	10	27/64	12,5	15	16	24	50	6
40	M 16	5/8-11	13,75	17/32	17	20	23	30	60	7
50	M 24	1-8	20,75	7/8	25	30	35	45	90	11
60	M 30	1 1/4-7	26	1 7/54	31	36	42	56	110	12

Table 23.11 Tool shanks for milling cutters (DIN 2207), all dimensions in mm (connecting dimensions for cutter spindle head according to DIN 2201)



Taper acc. to DIN 228		d_3		a	b	d_1	d_2	l_1	l_2	l_3	l_4	r	v
		Tol. medium											
		Metr.	Whitw.										
Morse taper	3	M 12	1/2"	5	24	23,825	36	81	86	12	18	1,6	0,03
	4	M 16	3/8"	6,5	32	31,267	43	102,5	109	15	23	1,6	
	5	M 20	3/4"	6,5	45	44,399	60	129,5	136	18	28	2	
	6	M 24	1"	8	65	63,348	84	182	190	25	39	3	
Metric taper	80	M 30	1 3/8"	8	80	80	120	196	204	28	44	3	0,04
	100	M 36	1 3/8"	10	100	100	145	232	242	30	48	3	
	120	M 36	1 3/8"	12	120	120	170	268	280	34	54	4	
	160	M 48	1 3/4"	16	160	160	220	340	356	42	66	4	0,05
	200	M 48	2"	20	200	200	270	412	432	50	78	6	0,07

Table 23.12 Diameter drilled for core holes for metric ISO normal thread according to DIN 13 (excerpt from DIN 13), all dimensions in mm

Nominal thread diameter d	Pitch	Drill- or counterbore diameter
M 3	0,5	2,5
M 4	0,7	3,3
M 5	0,8	4,2
M 6	1	5
M 8	1,25	6,8
M 10	1,5	8,5
M 12	1,75	10,2
M 16	2	14
M 20	2,5	17,5
M 24	3	21
M 27	3	24
M 30	3,5	26,5
M 36	4	32

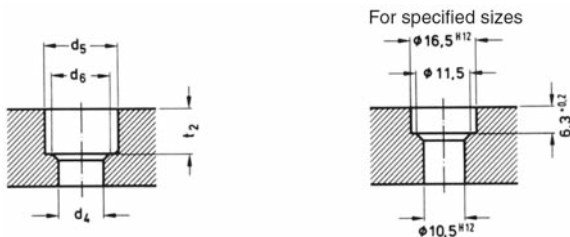
Table 23.13 Tap drill diameters for Whitworth threads, all dimensions in mm

Nominal thread diameter	Tap drill diameter	Nominal thread diameter	Tap drill diameter	Nominal thread diameter	Tap drill diameter
1/16	1,2	7/16	9,2	1 1/2	33,5
3/32	1,9	1/2	10,5	1 5/8	35,5
1/8	2,5	5/8	13,5	1 3/4	39
5/32	3,2	3/4	16,5	1 7/8	41
3/16	3,6	7/8	19,25	2	44
7/32	4,5	1	22	2 1/4	50
1/4	5,1	1 1/8	24,5	2 1/2	57
5/16	6,5	1 1/4	27,5	2 3/4	62
3/8	7,9	1 3/8	30,5	3	68

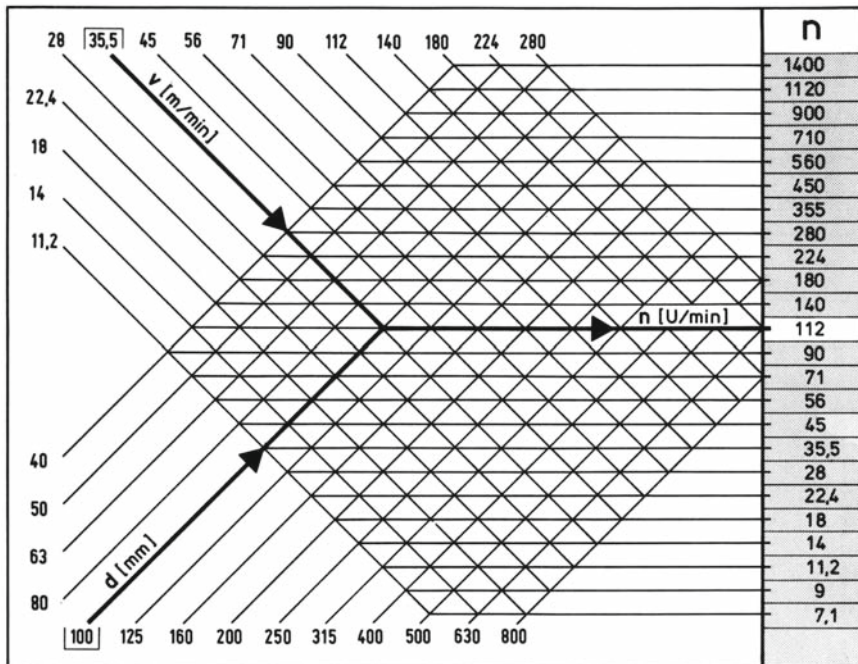
Table 23.14 Through holes according to DIN 69 for screws or similar parts with metric or fine screw thread – medium degree of accuracy (excerpt from DIN 69), sizes in mm

Thread diameter d_1	d_2 medium	Thread diameter d_1	d_2 medium
1	1,2	27	30
1,2	1,4	30	33
1,4	1,6	33	36
1,5	1,8	36	39
1,7	1,9	39	42
2	2,4	42	45
2,3	2,7	45	48
2,5	2,9	48	52
2,6	3	52	56
3	3,4	56	62
3,5	3,9	60	66
4	4,5	64	70
5	5,5	68	74
6	6,6	72	78
7	7,6	76	82
8	9	80	86
10	11	90	96
12	14	100	106
14	16	110	116
16	18	120	126
18	20	130	136
20	22	140	146
22	24	150	157
24	26		

Table 23.15 Counterbores for hexagon socket screws according to DIN 912 (excerpt from DIN 75 sheet 2), sizes in mm



Type	M					f				
	d_4 H 12	d_5 H 12	d_6	t_2 Accepted deviation		d_4 H 12	d_5 H 12	d_6	t_2 Acc. dev.	
4	4,8	8	—	4,6	+ 0,2	4,3	7,4	—	4,2	+ 0,2
5	5,8	10	—	5,7		5,3	9,4	—	5,2	
6	7	11	—	6,8		6,4	10,4	—	6,2	
8	9,5	14,5	—	9		8,4	13,5	9,4	8,3	
10	11,5	17,5	—	11		10,5	16,5	11,5	10,3	
12	14	20	—	13		13	19	15	12,3	
14	16	24	—	15		15	23	17	14,3	
16	18	26	—	17,5		17	25	19	16,5	
18	20	29	—	19,5		19	28	21	18,5	
20	23	33	—	21,5		21	31	23	20,5	
22	25	36	—	23,5		23	34	25	22,5	
24	27	39	30	25,5		25	37	28	24,5	
27	30	43	33	28,5		28	41	31	27,5	
30	33	48	36	32	+ 0,3	31	46	34	31	+ 0,3
33	36	53	39	35		34	51	37	34	
36	39	57	42	38		37	55	40	37	
42	45	66	48	44		43	64	46	43	
48	52	76	56	50		50	74	54	49	



24 Appendix

24.1 Test questions

On Chapter 2

1. How are the cutting edges on the tool wedge defined?
2. Sketch a tool wedge and mark the rake face.
3. Define the flank face and the angles α and γ with reference planes.
4. What is the denomination (Greek letter) of the rake angle?
5. Sketch a tool wedge. Draw in the angles α , β and γ . Explain with this sketch that the sum of the three angles remains 90° even when the rake angle is negative.
6. What are the effects of the rake face chamfer?
7. Explain why the tool tip must always be positioned above the workpiece centre.
8. Why do we select a large tool cutting edge angle for unstable workpieces ($l > 6 \cdot d$)?
9. With what variables can we calculate the sectional area of chip?
10. Which of these parameters can be set up on the machine?
11. Why do we need thickness of cut h ?
12. What is the difference between k_c , k_{ch} and $k_{c1,1}$?
13. How does the rake angle affect on the major cutting force F_c ?
14. Why can we neglect input power from the feed force when calculating the machine input power?

On Chapter 3

1. How is the term tool life defined?
2. Which technological parameter has the greatest effect on tool life?
3. What is the T - v curve?
4. What does the term “Width of flank bear land“ or “Wear of cutting edge” mean?
5. How does one calculate a cutting speed given a tool life of $T = 20$ min?
6. How does one find the permissible cutting speeds for specified cutting conditions and a predefined tool life?
7. How can the v values from the reference tables be converted into other tool life values?

On Chapter 4

1. What is a tool curve ?
2. What is meant by a machine curve?

On Chapter 5

1. What is the difference between the metal removal rate Q_w and the volume of the randomly arranged metal chips removed?
2. What is chip volume ratio?
3. Which chip shapes can be assigned to the chip volume ratios 100, 30 and 10?
4. What chip volume ratios are preferable in industrial manufacturing, and what are the reasons for this?

On Chapter 6

1. Name the cutting materials used in cutting technology.
2. Up to what temperatures do the cutting materials resist heat, and what results from this in terms of permissible cutting speeds?
3. Why is it only possible to use low cutting speeds ($v_c = 30\text{--}50$ m/min) for tools made of high-speed steel?
4. How are cemented carbides named?
5. What does the number after the ident letter of the cemented carbide name mean?
6. What type of cemented carbide should be used when cutting a high strength steel workpiece?
7. In which ranges are diamond tools used?

On Chapter 7

1. What turning methods are there?
2. From which variables can we determine the expected surface roughness?
3. What is the difference between face chuck and 3-jaw chuck?
4. Why is it better to rough-turn with constant sectional area of chip, high feed and low depth of cut, and not in the opposite way?
5. How can one calculate the machining time for cylindrical turning?
6. Why doesn't it make sense to rough-turn at very high cutting speeds? (Please explain with the equation for time- and power calculation).
7. Which turning tool shape is used for thread cutting?
8. What is a cutting tip?
9. What does the halved cone angle on the chip breaker of the turning tool cause?

On Chapter 8

1. What planing methods do you know?
2. How is the machining time calculated in planing?
3. Why is planing being replaced by milling?

On Chapter 9

1. Name all of the drilling techniques.
2. What does the feed f_z mean?
3. How can feed f be calculated during drilling?
4. Name the most essential elements of the twist drill.
5. What are the differences between the drill types N, H and W, and for what materials are they used?
6. Explain how twist drills are clamped into the drilling machine.
7. What are center drills used for?
8. What is the difference between a fixed and an adjustable reamer?
9. What went wrong if land wear on the twist drill is abnormally high?

On Chapter 10

1. Name the sawing procedures.
2. Why does $h = f_z$ in sawing?
3. Show the angles α , β and γ on the sketch of a saw tooth.
4. Why is it necessary to set the saw teeth?
5. What is a bi-metal saw band?
6. Explain the design of a segmented circular saw blade.

On Chapter 11

1. Explain the classification of milling techniques.
2. How is the term average chip thickness h_m defined?
3. By what parameter is sectional area of chip predominantly limited in milling?
4. What is the difference between feed per cutting edge f_z , feed per revolution f and feed rate v_f ?
5. Show the angles α , β and γ on the milling cutter blade.
6. What are the ranges of application for slide and face milling cutters and for cutter heads?
7. What is the function of the milling arbour?

8. What are the preferred cutting materials for slide and face milling cutters and cutter heads?

On Chapter 12

1. For what workpieces is the broaching procedure used?
2. What is the difference between pushing and pulling broaching?
3. How is the broaching tool named and designed?
4. Why do we use only one operation to generate the contour during broaching?

On Chapter 13

1. How are the grinding methods classified?
2. How is the workpiece feed generated in centreless through grinding?
3. What is meant by “hardness“of a grinding wheel? What are the symbols for hardness denomination?
4. What are the types of bonds (binders to hold the grinding grains together) do exist?
5. What types of abrasives are there?
6. What needs to be considered when clamping a grinding wheel?

On Chapter 14

1. What is meant by abrasive cutting?
2. What are the materials cut with this method?

On Chapter 15

1. What does abrasive belt grinding mean?
2. In which industries is this grinding method applied?

On Chapters 16 to 18

1. What kind of grinding technique is honing?
2. What is the name of the corresponding tool?
3. How does the superfinishing or superhoning procedure work?
4. What does lapping mean, and how does it work?
5. What are the typical features of dicing or wire cutting with slurry?
6. What is the dicing technique used for?

24.2 Comparison of old (German standard DIN) and new (European standard) material names

1.

Mild steels		
Unalloyed steels		
Material number	Formerly DIN 17100	New standard EN 10025
1.0035	St 33	S 185
1.0036	U St 37-2	S 235 J R G 1
1.0037	St 37-2	S 235 J R
1.0038	R St 37-2	S 235 J R G 2
1.0116	St 37-3	S 235 J 2 G 3
1.0044	St 44-2	S 275 J R
1.0144	St 44-3	S 275 J 2 G 3
1.0570	St 52-3	S 355 J 2 G 3
1.0050	St 50-2	E 295
1.0060	St 60-2	E 335
1.0070	St 70-2	E 360

2.

2.1.

Tempering steels		
Unalloyed		
Material number	Formerly DIN	New standard EN 10083
1.0301	C 10	C 10
1.0401	C 15	C 15
1.0402	C 22	C 22
1.0501	C 35	C 35
1.0503	C 45	C 45
1.0601	C 60	C 60
1.0605	C 75	C 75
1.1141	Ck 15	C 15 E
1.1151	Ck 22	C 22 E
1.1181	Ck 35	C 35 E
1.1191	Ck 45	C 45 E
1.1221	Ck 60	C 60 E
1.1248	Ck 75	C 75 E
1.1132	Cq 15	C 15 C
1.1152	Cq 22	C 22 C
1.1172	Cq 35	C 35 C
1.1192	Cq 45	C 45 C

2.	Tempering steels		
	Unalloyed		
2.1.	Material number	Formerly DIN	New standard EN 10083
	1.1140	Cm 15	C 15 R
	1.1149	Cm 22	C 22 R
	1.1180	Cm 35	C 35 R
	1.1201	Cm 45	C 45 R
	1.1223	Cm 60	C 60 R

2.2.	Alloyed tempering steels		
	Material number	Formerly DIN 17200	New standard EN 10083
	1.7034	37 Cr 4	37 Cr 4
	1.7035	41 Cr4	41 Cr 4
	1.7218	25 Cr Mo 4	25 Cr Mo 4
	1.7220	34 Cr Mo 4	34 Cr Mo 4
	1.7225	42 Cr Mo 4	42 Cr Mo 4
	1.6582	34 Cr Ni Mo 6	34 Cr Ni Mo 6

2.3.	Alloyed case-hardening steels		
	Material number	Formerly DIN 17210	New standard EN 10084
	1.7016	17 Cr 3	17 Cr 3
	1.7131	16 Mn Cr 5	16 Mn Cr 5
	1.7147	20 Mn Cr 5	20 Mn Cr 5
	1.5919	16 Cr Ni 6	16 Cr Ni 6
	1.6587	17 Cr Ni Mo 6	17 Cr Ni Mo 6
	1.7321	20 Mo Cr 4	20 Mo Cr 4

3.	Tool steels		
	Unalloyed cold-work steels		
3.1.	Material number	Formerly DIN 17350	New standard EN 96
	1.1730	C 45 W	C 45 U
	1.1740	C 60 W	C 60 U
	1.1620	C 70 W 2	C 70 W 2
	1.1525	C 80 W 1	C 80 U
	1.1830	C 85 W	C 85 U
	1.1545	C 105 W 1	C 105 U
	1.1640	C 10 W 2	C 105 W 2

3.2. Tool steels		
Alloyed cold-work steels		
Material number	Formerly DIN 17350	New standard EN 96
1.2436	X 210 Cr W 12	X 210 Cr W 12
1.2379	X 155 Cr V Mo 12-1	X 155 Cr V Mo 12-1
1.2210	115 Cr V 3	115 Cr V 3
1.2067	102 Cr 6	102 Cr 6
1.2838	145 V 33	145 V 33
1.2162	21 Mn Cr 5	21 Mn Cr 5
1.2842	90 Mn Cr V 8	90 Mn Cr V 8
1.2419	105 W Cr 6	105 W Cr 6
1.2550	60 W Cr V 7	60 W Cr V 7
1.2767	X 45 Ni Cr Mo 4	X 45 Ni Cr Mo 4
1.2764	X 19 Ni Cr Mo 4	X 19 Ni Cr Mo 4
1.2316	X 36 Cr Mo 17	X 36 Cr Mo 17
1.2323	48 Cr Mo V 6-7	48 Cr Mo V 6-7

3.3. Tool steels		
Hot-work steels		
Material number	Formerly DIN 17350	New standard EN 96
1.2713	55 Ni Cr Mo V6	55 Ni Cr Mo V6
1.2714	56 Ni Cr Mo V 7	56 Ni Cr Mo V 7
1.2343	X 38 Cr Mo V 5-1	X 38 Cr Mo V 5-1
1.2344	X 40 Cr Mo V 5-1	X 40 Cr Mo V 5-1
1.2365	X 32 Cr Mo V 33	32 Cr Mo V 12-28

3.4. Tool steels		
High-speed steels		
Material number	Formerly DIN 17350	New standard EN 96
1.3342	SC 6-5-2	HS 6-5-2C
1.3343	S 6-5-2	HS 6-5-2
1.3344	S 6-5-3	HS 6-5-3
1.3243	S 6-5-2-5	HS 6-5-2-5
1.3246	S 7-4-2-5	HS 7-4-2-5
1.3207	S 10-4-3-10	HS 10-4-3-10
1.3202	S 12-1-4-5	HS 12-1-4-5
1.3255	S 18-1-2-5	HS 18-1-2-5

4.

Anticorrosive steels		
Stainless steels		
Material number	Formerly DIN 17440	New standard EN 10988
1.4000	X 6 Cr 13	X 6 Cr 13
1.4006	X 12 CR 13	X 10 Cr 13
1.4057	X 20 Cr Ni 17	X 19 Cr Ni 17-2
1.4104	X 12 Cr Mo S 17	X 14 Cr Mo S 17
1.4301	X 5 Cr Ni 18-10	X 4 Cr Ni 18-10
1.4306	X 2 Cr Ni 18-9	X 2 Cr Ni 19-11
1.4401	X 5 Cr Ni Mo 17-12-2	X 4 Cr Ni Mo 17-12-2
1.4541	X 10 Cr Ni Ti 188	X 2 Cr Ni Mo 18-14-3
1.4435	X 2 Cr Ni Mo 18-14-3	X 2 Cr Ni Mo 18-14-3
1.4541	X 6 Cr Ni Ti 18-10	X 6 Cr Ni Ti 18-10
1.4571	X 6 Cr Ni Mo Ti 17-12-2	X 6 Cr Ni Mo Ti 17-12-2

5.

Soft unalloyed steels		
Sheets for deep drawing		
Material number	Formerly DIN 1624	New standard EN 10139
1.0330	St 12	D C 01
1.0333	U St 13	D C 03 G 1
1.0347	R R St 13	D C 03
1.0338	St 14	D C 04

6.

Unalloyed low-carbon steels		
for bolts, screws, rivets		
Material number	Formerly DIN 1654	New standard EN 10025
1.0203	U St 36	C 11 G 1
1.0204	U Q St 36	C 11 G 1C
1.0205	R St 36	C 11 G 2
1.0217	U St 38	C 14 G 1
1.0224	U Q St 38	C 14 G 1 C
1.0223	R St 38	C 14 G 2
1.0708	U 7 S 6	C 7 R G 1
1.0702	U 10 S 10	C 10 R G 1

7.

Aluminium wrought alloys		
Material number	Formerly DIN 1700 DIN 1725 T 1	New standard EN 573 T 3
3.0255	Al 99,5	EN AW-Al 99,5
3.0515	Al Mn 1	EN-AW-Al Mn 1
3.1325	Al Cu Mg 1	EN-AW-Al Cu 4 Mg Si (A)
3.1355	Al Cu Mg 2	EN-AW-Al Cu 4 Mg 1
3.2315	Al Mg Si 1	EN-AW-Al Si 1 Mg Mn
3.3535	Al Mg 3	EN-AW-Al Mg 3
3.3555	Al Mg 5	EN-AW-Al Mg 5
3.4365	Al Zn Mg Cu 1,5	EN-AW-Al Zn 5,5 Mg Cu

8.

Cast iron			
with lamellar graphite			
According to DIN 1691		According to DIN EN 1561	
Material number	Code designation	Material number	Code designation
0.6010	GG-10	EN-JL 1010	EN-GJL-100
0.6015	GG-15	EN-JL 1020	EN-GJL-150
0.6020	GG-20	EN-JL 1030	EN-GJL-200
0.6025	GG-25	EN-JL 1040	EN-GJL-250
0.6030	GG-30	EN-JL 1050	EN-GJL-300
0.6035	GG-35	EN-JL 1060	EN-GJL-350
With spheroidal graphite			
According to DIN 1693		According to DIN EN 1563	
0.7033	GGG-40	EN-JS 1030	EN-GJS-400-15
0.7050	GGG-50	EN-JS 1050	EN-GJS-500-15
0.7060	GGG-60	EN-JS 1060	EN-GJS-600-15
0.7070	GGG-70	EN-JS 1070	EN-GJS-700-15
0.7080	GGG-80	EN-JS 1080	EN-GJS-800-15

9.

Cast steel		
Material number	Former name DIN 1681	DIN EN 10027 new
1.4020	GS 38	GE 200
1.0446	GS 45	GE 240
1.0552	GS 52	GE 260
1.0558	GS 60	GE 300
Alloyed cast steel		
1.5419	GS 20 Mn 5	G 20 Mn 5

10.

Copper wrought alloys			
For cold working			
Material number	Formerly DIN 17660	New standard EN 12449	New material number
2.0060	E-Cu	Cu-DHP	CW 024 A
2.0230	Cu Zn 10	Cu Zn 10	CW 501 L
2.0240	Cu Zn 15	Cu Zn 15	CW 502 L
2.0261	Cu Zn 28	Cu Zn 28	CW 504 L
2.0265	Cu Zn 30	Cu Zn 30	CW 505 L
2.0321	Cu Zn 37 (Ms 63)	Cu Zn 37	CW 508 L
2.0402	Cu Zn 40 Pb 2	Cu Zn 40 Pb 2	CW 617 N
2.0460	Cu Zn 20 Al 2	Cu Zn 20 Al 2 As	CW 702 R
2.0470	Cu Zn 28 Sn 1	Cu Zn 28 Sn 1 As	CW 706 R
2.0918	Cu Al 15	Cu Al 15 As	CW 300 G

For additional new material names according to the European standard, please consult:

For steels:

Stahl-Eisen-Liste 10th edition 1998
Verlag Stahleisen mbH
Sohnstr. 65, 40237 Düsseldorf, Germany

For aluminium materials:

Aluminium-Merkblatt W2 (leaflet)
Aluminium-Zentrale
Am Bonnheshof 5, 40470 Düsseldorf, Germany

For copper materials:

Auskünfte im Deutschen Kupferinstitut (DKI) (information)
Beethovenstr. 21, 40233 Düsseldorf, Germany

24.3 Firm addresses

The figures and information in this textbook were made available courtesy of the following firms.

I thank these companies.

Prof. Dr.-Ing. h.c. Tschätsch

Drilling*Drills*

*Deutsche Spiralbohrer u. Werkzeugfabriken –
DSW - Remscheid -
Postf. 110511; 42865 Remscheid
www.dsw-remscheid.de*

*Fa. Gottlieb Gühring
Spiralbohrer und Masch.-Fabrik
Postf. 247; 72423 Albstadt
www.guehring.de*

ABDW GmbH,

*Präzisionswerkzeugfabrik
Postfach 103522; 70030 Stuttgart*

*Fa. Hermann Bilz GmbH
Postf. 5060; 73716 Esslingen
www.hermann-bilz.de*

*Fa. Wilhelm Fette GmbH
Postf. 1180; 21484 Schwarzenbeck
www.fette.de*

WIDIA GmbH

Postf. 102161; 45021 Essen

Fa. R. Stock AG Präzisionswerkzeuge

Postf. 480320; 12253 Berlin

www.widia.de

August Beck GmbH

Präzisionswerkzeugfabrik

Postf. 1241; 72471 Winterlingen

www.august-beck.de

Fa. Günther GmbH TITEX-PLUS

Postf. 940270; 60460 Frankfurt

www.titex.de

Thread cutting tools*Fa. Joseph Boss GmbH*

Postf. 150; 72445 Albstadt

www.johs-boss.de

Fa. Gertus- Werkzeugfabrik

Paul Dambacher

Schmiedestr. 10; 42899 Remscheid

www.gertus.de

Fa. Fr. Piltz + Sohn KG

Postf. 1709; 89507 Heidenheim

www.piltz.de

Fa. Adolf Corts

Ibacher Str. 8; 42855 Remscheid

www.corts.de

Fa. R. Stock, Präzisionswerkzeuge

Postf. 480320; 12253 Berlin

www.stock.de

Boring tools*Fa. Emil Wohlhaupter und Co.*

Postf. 1264; 72633 Frickenhausen

www.wohlhaupter.de

Fa. Röhm GmbH

Postf. 1161; 89565 Sontheim/Brenz

www.roehm-spannzeuge.com

Fa. Gottlieb Peiseler GmbH

Postf. 150157; 42828 Remscheid

www.peiseler.de

Reamers*Fa. August Beck*

Werkzeugfabrik

Postf. 1241; 72474 Winterlingen

www.august-beck.de

Werkzeugfabrik Königsee GmbH

Werkstr. 5; 07426 Königsee

www.werkoe.de

Broaching**Broaches***Fa. Karl Klink GmbH*

Werkzeug- und Maschinenfabrik

Postf. 1140; 75218 Niefern

www.karl-klink.de

Turning**Diamond turning tools and holders***Fa. Indimant*

Postfach 1364; 22935 Bargtheide

www.indimant.de

Fa. Jakob Lach

Diamant- Werkzeugfabrik

Postf. 1819; 63408 Hanau

www.lach-diamant.de

Fa. Winter GmbH

Diamantwerkzeuge

Postf. 2049; 22841 Norderstedt

www.winter-diamant-werkz-saint-gobain.de

High-speed steel cutter bits and cutting tips made of cemented carbide and ceramic inserts and clamp-type tool holders*Böhler Werkzeugstahl GmbH*

Hansa Allee 321; 40549 Düsseldorf

www.boehler.de

WIDIA GmbH

Münchner Str. 90; 45149 Essen

www.widia.com

Sandvik GmbH

Postf. 104451; 40035 Düsseldorf

www.sandvik.de

KOMET-Präzisions-Werkzeuge

Robert Breuning GmbH

Postf. 1361; 74351 Besigheim

www.komet.de

Kennametal Hertel AG

Wehlauer Str. 73; 90766 Forth

www.kennametal.com

Fa. SUMI TOMO

Siemensring 84; 47877 Willich

Fa. Burgsmüller GmbH

Postf. 5; 37541 Kreiensen

www.burgsmueller.de

TRIBO Hartmetallwerk

Am Bahnhof 5; 36433 Immelborn

www.tribo.de

*Fa. Böhlerit GmbH und Co.**Hartmetallwerkzeuge*

Heidenheimer Str. 108; 73447

Oberkochen

Milling***Milling cutters and circular saws for metal sawing****Fa. ALBERG-Remscheid**Alfred Berghaus GmbH*

Postf. 140102; 42822 Remscheid

www.alberg.de

Fa. Edmund Drögemeyer

Postf. 100250; 42802 Remscheid

*Franken-Fabrik für Präzisionswerkzeuge**R. Voigt GmbH*

Postf. 20; 90603 Rückersdorf

Fa. Günther GmbH TITEX-PLUS

Postf. 940270; 60460 Frankfurt

*Fa. Gliason-Hurth**Maschinen und Werkzeuge*

Moosacher Str. 36; 80809 München

Fa. Gebr. Saacke Werkzeugfabrik

Kanzler Str. 250; 75181 Pforzheim

Kennametal Hertel AG

Wehlhauer Str.73; 90766 Forth

ILIX Präzisionswerkzeuge GmbH

Gutenbergstr. 5; 65830 Kriftel

www.ilix.de

*Fa. Wilhelm Fette GmbH**Präzisionswerkzeuge*

Postf. 1180; 21484 Schwarzenbeck

www.fette.de

*Schuler Technoplan GmbH and Co.**Metallkreissägen und Formfräsefabrik*

Industriestr. 91; 75417 Mühlacker

Fa. Stefan Hertweck GmbH

Postf. 1320; 76533 Gaggenau

www.hertweck-praezisionswerkzeuge.de

Honing***Honing tools and holders****Fa. Hommel GmbH,**Präzisionswerkzeuge*

50763 Köln

www.hommel-keller.de

Masch.-Fabrik Gehring GmbH und Co.

Gehringstr.; 73760 Ostfildern/Nell.

www.gehring.de

Fa. Ernst Winter und Sohn

Postf. 2049; 22841 Hamburg

Sawing***Sawing tools (saw blades, saw belts and circular saw blades)****Fa. Theodor Flamme**Sägen- und Werkzeugfabrik Abt. WB*

Postf. 347; 36003 Fulda

www.flamme-saegen.de

*Fa. KOMET Metallsägenfabrik**Robert Breuning GmbH*

Postf. 1507; 79550 Weil am Rhein

www.komet.de

Fa. Wilh. Arntz

Postf. 100152; 42801 Remscheid

www.arntz.de

*Fa. August Blecher**Sägen-, Messer- und Werkzeugfabrik*

Wüstenhagener Str.65; 42801 Remscheid

www.blecher.com

*Fa. Dress Werkzeuge**Hentschke GmbH und Co.*

Postf. 1151; 75439 Otisheim

www.dress-tools.de

*Fa. Friedrich Ohler**Werk Vieringhausen*

Postf. 100762; 42807 Remscheid

ILIX-Präzisionswerke GmbH

Gutenbergstr. 5; 65830 Kriftel

www.ilix.de

*Fa. Friedr. Reber GmbH**Spez.-Fabrik für Metallkreissägeblätter*

Ellwanger Str. 97; 73441 Bopfingen

Grinding***Grinding tools for surface-, cylindrical- and centreless grinding***

Fa. Fickert und Winterling
Maschinen- und Schleifscheibenfabrik
 Postf. 120; 95601 Marktredwitz

Fa. Jakob Lach GmbH
Diamant-Werkzeugfabrik
 Postf. 1819; 63408 Hanau
 www.lach-diamant.de

Naxos-Union
Schleifmitte- und Schleifmasch.-Fabrik
 Werner von Siemens Str. 1
 35510 Butzbach
 www.naxos-diskus.de

ELB-Schliff-Werkzeuge GmbH
 Edmund Lange Str. 27; 64832
 Babenhausen

Carborundum-Deutschland GmbH
 Kappeler Str. 105; 40597 Düsseldorf
 www.carborundum-schleifmittel.de

Diskus-Werke
 Pittlerstr. 6; 63225 Langen
 www.diskus-werke.de

Tool holders and quick-change tool holders

Gebr. Boehringer GmbH
 Postf. 220; 73002 Göppingen
 www.boehringer-werkzeugmaschinen.de

WIDIA GmbH
 Münchner Str. 90; 45145 Essen
 www.widia.com

Fa. Georg Hufnagel
 Schweinauer Hauptstr. 1; 90441
 Nürnberg

Fa. Böhlerit GmbH und Co.
 Heidenheimer Str. 108; 73447
 Oberkochen

Fa. Albert Klopfer GmbH
 Postf. 1180; 71264 Renningen
 www.original-klopfer.de

Komet-Stahlhalter- und Werkzeugfabrik
Robert Breuning GmbH
 Postf. 1361; 74351 Besigheim
 www.komet.de

Fa. Röhm
 Postf. 1161; 89565 Sontheim/Brenz
 www.roehm-spannzeuge.de

Clamping attachment Turning- and drill chucks

Fa. Rudolf Buschmann
Spannzeuge GmbH
 Postf. 700105; 42526 Velbert

Fa. Fahrion, Präzisionswerkzeugfabrik
 Forststr. 54; 73667 Kaiserbach
 www.fahrion.de

Fa. Paul Forkard KG
 Postf. 3442; 40684 Erkrath
 www.forkard.com

*Fa. Kelch und Co., Werkzeugmaschinen-
 fabrik*
 Postf. 1440; 73504 Schorndorf
 www.kelch.de

Fa. Berg und Co. Spanntechnik
 Postf. 110144; 33661 Bielefeld
 www.original-klopfer.de

Fa. Albert Klopfer GmbH
 Postf. 1180; 71264 Renningen

Milling collets, arbors taper sockets

Fa. Hahn und Kolb, Abt. Werkzeuge
 Borsigstr. 50; 70469 Stuttgart
 www.hahn-kolb.de

ABDW GmbH, Präzisionswerkzeugfabrik
 Postf. 103522; 70030 Stuttgart

Fa. Wilhelm Bahn Müller
 Postf. 280; 73652 Plüderhausen

Emuge Werk, Richard Glimpel
 Nürnberger Str. 96; 91027 Lauf/Pegnitz
 www.emuge.de

Fa. Wilhelm Fette GmbH
 Postf. 1180; 21484 Schwarzenbeck
 www.fette.de

Fa. Ringspann, Albrecht Maurer KG
 Postf. 2155; 61291 Bad Homburg
 www.ringspann.de

Fa. Karl Schüssler, Fräaserspannzeuge
 Bahnhofstr. 108; 72411 Bodelshausen
 www.k-schuessler.de

Fa. Hainbuch
 Spannende Technik
 Erdmannshäuser Str. 57, 71672 Marbach
 www.hainbuch.de

For manufacturer's documentation of machine tools, see the following schedules of manufacturers:

- 1 Bezugsquellenverzeichnis der Fachgemeinschaft Werkzeugmaschinen und des Vereins Deutscher Werkzeugmaschinenfabriken e.V. (VDW) Geschäftsstelle: 60948 Frankfurt; Postf. 71064, Germany.
- 2 Wer baut Maschinen – Fachquellenverzeichnis für Maschinen und Maschinenelemente. Available for purchase from: Verlag Hoppenstedt GmbH, Havelstr. 9; 64295 Darmstadt, Germany.
- 3 Schweizer Werkzeugmaschinen und Ausrüstungen für die Fertigungstechnik (VSM), Kirchenweg 4, CH-8032 Zürich, Switzerland.

References

1 Textbooks

1. *Bergmann*, Werkstofftechnik Teil 1 und 2, Carl Hanser Verlag, München 1998
2. *H. Berns*, Stahlkunde für Ingenieure, Springer Verlag, Berlin-Heidelberg 1993
3. Verein Deutscher Eisenhüttenleute; Stahl-Eisen-Liste 10. Auflage 1998, Verlag Stahleisen, Düsseldorf
4. *Seidel*, Werkstofftechnik, 7. Aufl. 2006, Hanser Fachbuchverlag, München
5. *Weißbach*, Werkstoffkunde und Werkstoffprüfung 15. Aufl. 2004 Vieweg Verlag, Wiesbaden
6. *Schatt/Wieters*, Pulvermetallurgie, VDI-Verlag Düsseldorf
 - Technologie und Werkstoffe, 1994
 - Sintervorgänge, 1992
7. *Tietz*, Technische Keramik, VDI-Verlag, Düsseldorf 1994
8. *Schäning*, DIN-Normenheft 3 Werkstoffkurznamen und Werkstoffnummern für Eisenwerkstoffe, Verlag Stahl-Eisen, 1994
9. *G. Spur/T. Stöferle*, Handbuch der Fertigungstechnik Band 3 Spanen, Carl Hanser Verlag, München, 1980
10. W. König, Fertigungsverfahren, VDI-Verlag, Düsseldorf
 - Band 1: Drehen, Fräsen, Bohren, 2002
 - Band 2: Schleifen, Honen, Läppen, 2005
 - Band 3: Abtragen und Generieren, 2006
11. *Degner, Lutze, Smekal*, Spanende Formung, Carl Hanser Verlag, 1993
12. *Fritz*, Fertigungstechnik, Springer Verlag, Berlin-Heidelberg, 2006
13. *Tönshoff*, Spanen, Springer Verlag, Berlin-Heidelberg, 2004
14. *Warnecke/Westkämper*, Einführung in die Fertigungstechnik, Teubner Verlag, Stuttgart, 2006
15. *W. Krause*, Fertigung in der Feinwerktechnik und Mikrotechnik, Carl Hanser Verlag, München, 1996,
16. *G. Spur*, Keramikbearbeitung, Carl Hanser Verlag, 1989
17. *Pauksch*, Zerspantechnik, Vieweg Verlag, Wiesbaden, 1996
18. *Reichert*, Fertigungstechnik 1, Verlag Handwerk und Technik, Hamburg, 1996
19. Fachkunde Metall, Europa Lehrmittel, Haan-Gruiten, 2003
20. *Krist*, Formeln und Tabellen Zerspantechnik, Vieweg Verlag, Wiesbaden, 1996
21. *K. Weinert*, Spanende Fertigung, Vulkan Verlag, Essen, 1994
22. *Salje*, Begriffe der Schleif- und Konditioniertechnik, Vulkan Verlag, Essen, 1991
23. *Horsemann*, Hochgeschwindigkeitsschleifen mit aktiv magnetgelagerten Spindeln, Vulkan Verlag, Essen, 1993
24. *M. Klyk*, Hochgeschwindigkeitsschleifen mit CBN, Vulkan Verlag, Essen, 1993
25. *Tikal/Kammermeier*, Vollhartmetallbohrer und Fräser, Verlag moderne Industrie, Landsberg/Lech, 1993
26. *Wojan/Breitkopf*, Übungsbuch Fertigungstechnik, Vieweg Verlag, Wiesbaden, 1996

27. *Bruins/Dräger*, Werkzeuge und Werkzeugmaschinen Teil 1, Carl Hanser Verlag, München, 1989
28. *Tschätsch/Charchut*, Werkzeugmaschinen, Carl Hanser Verlag, München, 1991
29. *Weck*, Werkzeugmaschinen und Fertigungssysteme
 Band 1: Maschinenarten, Bauformen, Anwendungsbereiche, 1991
 Band 2: Konstruktion und Berechnung, 1994 VDI-Verlag, Düsseldorf
30. Hartmetallwerkzeuge mit Richtwerten für die Zerspannung, Firmenschriften der Firmen:
 Widia-GmbH, Essen
 Kennametal Hertel, Fürth
 Sandvik/Coromant, Düsseldorf
 Sumitomo Electric-Hartmetall GmbH, Willich
31. k.F. Toellner, Weiterentwicklung der Schneidstoffe
 Firmenveröffentlichung der Firma Widia GmbH, Essen
32. Firmenschrift, Naxos Union, Schleifscheiben und andere Schleifkörper Naxos-Union, Frankfurt/M.
33. Herausgeber: Fa. Ernst Winter und Sohn, Schleiftechnisches Handbuch Schleifen mit Diamant und CBN, Vulkan Verlag, Essen, 1988
34. *Künanz, Knösel, Seifert, Lösche, Gaßmann*: „Werkstückqualität und Produktivität beim Drahttrennläppen von nichtmetallischen und metallischen Werkstoffen“. In: Jahrbuch Schleifen, Honen, Läppen und Polieren, Ausgabe 61, 2004, S. 233

2 ISO standards

Tools and clamping devices

- ISO 237 Rotating tools with parallel shanks; Diameters of shanks and sizes of driving squares
- ISO 240 Milling cutters – Interchangeability dimensions for cutter arbors or cutter mandrels
- ISO 241 Shanks for turning and planing tools – Shapes and dimensions of the section
- ISO/R 296 Machine tools, Morse tapers and metric tapers
- ISO 513 Application of carbides for machining by chip removal; designation of the main groups of chip removal and groups of application; Amendment 1: Designation of hard cutting materials; Type A
- ISO 866 Centre drills for centre holes without protecting chamfers; Type A
- ISO 1119 Geometrical Product Specifications (GPS) – Series of conical tapers and taper angles
- ISO/DIS 1832.2 Indexable inserts for cutting tools – Designation; Technical Corrigendum 1
- ISO 2306 Drills for use prior to tapping screw threads
- ISO 2540 Centre drills for centre holes with protecting chamfer – Type B
- ISO 2541 Centre drills for centre holes with radius form – Type R
- ISO 3002/1 Basic quantities in cutting and grinding; Part 1: Geometry of the active part of cutting tools; general terms, reference systems, tool and working angles, chip breakers

- ISO/DIS 4203 Parallel shank tools – Driving tenons and sockets - Dimensions
 ISO 5413 Machine tools – positive drive of Morse tapers

Drills

- ISO 235/1 Parallel shank jobber and stub series drills and Morse taper shank drills
 ISO 494 Parallel shank twist drills – Long series
 ISO 866 Centre drills for centre holes without protecting chamfers – Type A
 ISO 2540 Centre drills for centre holes with protecting chamfer – Type B
 ISO 2541 Centre drills for centre holes with radius form – Type R
 ISO 3291 Extra-long Morse taper shank twist drills
 ISO 3292 Extra-long parallel shank twist drills
 ISO 3438 Subland twist drills with Morse taper shanks for holes prior to tapping screw threads
 ISO 3439 Subland twist drills with cylindrical shanks for holes prior to tapping screw threads
 #ISO/DIS 3440 Twist drills with indexable inserts made of cemented carbide, with parallel shank, for metal and plastics (Translation from German)
 #ISO/DIS 3441 Twist drills with indexable inserts made of cemented carbide, with Morse taper shank, for metal and plastics (Translation from German)
 ISO 235/11 Parallel shank jobber and stub series drills and Morse taper shank drills
 ISO 3293 Morse taper countersinks for angles 60, 90 and 120 degrees inclusive
 ISO 3294 Parallel shank countersinks for angles 60, 90 and 120 degrees inclusive
 ISO 3314 Shell drills with taper bore (taper bore 1:30 (included)) with slot drive
 ISO 4204 Countersinks 90°, with Morse taper shanks and detachable pilots
 ISO 4205 Countersinks 90°, with parallel shanks and solid pilots
 ISO 4206 Counterbores with parallel shanks and solid pilots
 ISO 4207 Counterbores with Morse taper shanks and detachable pilots

Reamers

- ISO 236/I Hand reamers
 ISO 236/II Machine reamers with Morse taper shank and long cutting blades (Translation from German)
 ISO 521 Machine chucking reamers with parallel shanks or Morse taper shanks
 ISO 522 Special tolerances for reamers
 ISO 2238 Machine bridge reamers
 ISO 2250 Finishing reamers for Morse and metric tapers, with parallel shanks and Morse taper shanks
 ISO 2402 Shell reamers with taper bore (taper bore 1:30 (included)) with slot drive and arbors for shell reamers
 ISO 3465 Hand taper pin reamers
 ISO 3466 Machine taper pin reamers with parallel shanks
 ISO 3467 Machine taper pin reamers with Morse taper shanks

Taps

ISO 529	Short machine taps and hand taps
ISO 2283	Long shank taps with nominal diameters from M3 to M24 and 1/8 in to 1 - reduced shank taps
ISO 2284	Hand taps for parallel and taper pipe threads – General dimensions and marking
ISO 2306	Drills for use prior to tapping screw threads
ISO 2568	Hand- and machine operated circular screwing dies and hand-operated die stocks

Turning tools

ISO 241	Shanks for turning and planing tools – Shapes and dimensions of the section
ISO 242	Carbide tips for brazing on turning tools
ISO 243	Turning tools with carbide tips; External tools
ISO 504	Turning tools with carbide tips; Designation and marking
ISO 514	Turning tools with carbide tips; Internal tools
ISO 883	Indexable hardmetal (carbide) inserts with rounded corners, without fixing hole; Dimensions
ISO 1832	Indexable inserts for cutting tools - Designation
ISO 3286	Single point cutting tools; corner radii
ISO 3364	Indexable hardmetal (carbide) inserts with rounded corners, with cylindrical fixing hole - Dimensions
ISO 3685	Tool-life testing with single-point turning tools
ISO/DIS 5421	Ground high speed tool bits

Milling cutters

ISO 523	Milling cutters; Recommended range of outside diameters
ISO 883	Indexable hardmetal (carbide) inserts with rounded corners, without fixing hole; Dimensions
ISO/DIS 1641/I	End mills and slot drills - Part I: Milling cutters with cylindrical shanks (Revision of ISO/R 1641-1970, Section 3)
ISO/DIS 1641/II	End mills and slot drills - Part II: Milling cutters with Morse taper shanks (Revision of ISO/R 1641-1970, Section 4)
ISO/DIS 1641/III	End mills and slot drills - Part III: Milling cutters with 7/24 taper shanks (Revision of ISO 2324-1972)
ISO 2584	Cylindrical cutters with plain bore and key drive - Metric series
ISO 2585	Slotting cutters with plain bore and key drive – Metric series
ISO 2586	Shell end mills with plain bore and tenon drive – Metric series
ISO 2587	Side and face milling cutters with plain bore and key drive - Metric series
ISO 2780	Milling cutters with tenon drive – Interchangeability dimensions for cutter arbors – Metric series

ISO 2940/I	Milling cutters mounted on centring arbors having a 7/24 taper; Fitting dimensions; Centring arbors
ISO 2940/II	Milling cutters mounted on centring arbors having a 7/24 taper; Inserted tooth cutters
ISO 3337	T-slot cutters with cylindrical shanks and Morse taper shanks having tapped hole
ISO 3338/I	Cylindrical shanks for milling cutters – Part 1: Dimensional characteristics of plain cylindrical shanks
ISO 3338/II	Cylindrical shanks for milling cutters – Part 2: Dimensional characteristics of flatted cylindrical shanks
ISO/DIS 3365/1.2	Indexable hardmetal (carbide) inserts with wiper edges, without fixing hole - Dimensions
ISO/DIS 3855	Milling cutters – Nomenclature
ISO 3859	Inverse dovetail cutters and dovetail cutters with cylindrical shank
ISO 3860	Bore cutters with key drive - Form milling cutters with constant profile
ISO 3940	Tapered die-sinking cutters with parallel shanks

Saw blades

ISO 2296	Metal slitting saws with fine and coarse teeth – Metric series
ISO 2336	Hacksaw blades – Part 1 and 2; Dimensions for hand- and machine-blades
ISO 2924	Solid and segmental circular saws for cold cutting of metals – Interchangeability dimensions of the drive – Saw diameter range 224 to 2240 mm
ISO/DIS 4875/I	Metal-cutting band saw blades, Part 1: Vocabulary
ISO/DIS 4875/II	Metal-cutting band saw blades – Part 2: Characteristics and dimensions
ISO/DIS 4875/III	Metal-cutting band saw blades – Part 3: Characteristics of saw blade types

Grinding wheels

ISO 525	Bonded abrasive products – General requirements
ISO/R 603	Bonded abrasive products; Grinding wheel dimensions, Part 1
ISO 666	Machine tools – Mounting of grinding wheels by means of hub flanges
ISO 1117	Bonded abrasive products; Grinding wheel dimensions, Part 2
ISO 2220	Hand finishing sticks and oil stones; Dimensions
ISO 2933	Bonded abrasive products; Grinding wheel dimensions, Part 3
ISO 3920	Honing stones of square section; Designation and dimensions
ISO 3921	Honing stones of rectangular section; Designation and dimensions
ISO 1929	Abrasive belts; Designation, dimensions and tolerances
ISO 2235	Abrasive sheets – Dimensions, tolerances and designation
ISO 2421	Coated abrasives – Cylindrical sleeves
ISO 2422	Truncated cone abrasive sleeves; Dimensions and designation
ISO 2976	Coated abrasives – Abrasive belts – Selection of width/length combinations

3 VDI directions

General

No. of direction

VDI

2003 01.76 Chip-forming machining of plastics / 7 p.

3321 03.94 Optimisation of cutting; basis / 16 p.

VDI/DGQ

3441 03.77 Statistical testing of the operational and positional accuracy of machine tools; Basics 21 p.

3442 03.77 Statistical examination of exactly working of turning machines / 7 p.

3443 03.77 Statistical examination of exactly working of milling machines / 11 p.

3444 09.78 Statistical control of exactly working and positioning of coordinate drilling machines and machining centers / 18 p.

3445 sheet 1 03.77 Statistical examination of exactly working of grinding machines, Fundamentals.

3445 sheet 2 03.77 Statistical examination of exactly working of grinding machines; external cylindrical grinding machines with center points; plunge cut grinding operation / 3 p.

3445 sheet 3 03.77 Statistical examination of exactly working of grinding machines; centerless external cylindrical grinding machines / 4 p.

3445 sheet 4 03.77 Statistical examination of exactly working of grinding machines; internal grinding machines / 4 p.

3445 sheet 5 03.77 Statistical examination of exactly working of grinding machines; Flat grinders / 4 p.

Turning

3206 10.94 Layout of turning processes / 27 p.

Drilling, countersinking/ counterboring, reaming

3208 E 08.93 Guidelines for gun drilling / 16 p.

3209 sh. 1 02.89 Deep hole boring; approximate values for deep hole boring with external supply of the coolant / 12 p.

3209 sh. 2 09.92 Deep hole boring; approximate values for the skiving and roller burnishing of bores / 7 p.

3210 sheet 2 10.86 Deep boring equipment; form for enquiry, quoting and ordering / 6 p.

Milling

3333 09.77 Hobbing of spur gears with involute profile / 56 p.

Grinding

- 3390 10.91 Creep feed grinding / 19 p.
- 3394 06.80 Arrangement and use of diamond and CBN grinding devices for metal working / 9 p.
- 3396 Belt grinding for metal working
- 3397 Maintenance of metalworking fluids for grinding (A 1/75)
- 3399 03.86 Truing and dressing of grinding wheels with conventional abrasives

Miscellaneous**VDI/VDE**

- 2601 10.91 Requirements on the surface structure to cover function capability of surfaces manufactured by cutting; list of parameters / 14 p.

VDI/VDE

- 2603 09.90 Methods of surface measurement; measurement of profile bearing length ratio / 6 p.

VDE/VDI

- 2604 06.71 Surface measuring methods; roughness analysis by means of interference microscopy

VDI/VDE

- 2606 06.91 Inspection of hobs for involute gears (cylindrical gears)
- 2607 E 06.95 Computer-aided evaluation of profile and helix measurements on cylindrical gears with involute profile / 25 p.
- 2608 02.75 Tangential composite and radial composite inspection of cylindrical gears, bevel gears, worms and worm wheels / 19 p.
- 2612 sheet 1 11.78 Profile and helix checking of involute cylindrical gears / 12 p.
- 2612 sheet 2 09.80 Profile and helix checking of involute cylindrical gears / 20 p.
- 3320 sheet 2 E 07.78 Tool numbering – tool systems; tools for master forming, material preparation; material-deforming process / 40 p.
- 3320 sh. 3 07.76 Tool numbering – tool systems; tools for severing, combined severing and forming, removal options, cleaning / 27 p.
- 3320 sh. 6 07.75 Tool numbering – tool systems; tools for joining (decomposing), coating, changing material properties / 30 p.
- 3320 sh. 7 03.75 Tool numbering – tool systems; tools without allocation to procedures (predominantly hand tools outside the ranges 1-6) / 23 p.
- 3322 04.85 Multi-spindle automatic lathe; standards for machine equipment and operation / 15 p.
- 3323E 07.94 Information on applicability of hard cutting materials for machining by chip removal / 8 p.

Glossary

- 3-jaw chuck 60
- Abrasive 272, 295
- Abrasive belt grinding 297
- Abrasive cutting 295
- Accuracies feasible with drilling 109
 - Abrasive belt grinding 297
 - Broaching 227
 - Grinding 264
 - Lapping 311
 - Milling 179
 - Planing 98
 - Sawing 149
 - Slotting 98
 - Superfinishing 309
 - Turning 58
- Adaptor sleeve 211
- Angle milling cutter 199
- Angle of approach
 - Grinding 266
 - Milling 179
 - Sawing 155
- Angles for the
 - Broach 225
 - Milling cutter 191, 194
 - Saw blade 164
 - Turning tool 10
 - Twist drill 106
- Average chip thickness 181
- Boring 105
- Broaching 225
- Broaching tools 234
- Calculation of force and power
 - Broaching 228
 - Drilling 109
 - Grinding 264
 - Milling 179
 - Planing 99
 - Sawing 149
 - Turning 68
- Carriers on tools with parallel shanks 37
- Cemented carbides 45, 317
 - Cermets 318
 - coated 318
 - uncoated 317
- Centre drills 130
- Ceramics 46, 322
- Characteristics of dulling 26
- Chip breakers 81
- Chip shapes 39
- Chip volume ratio 39
- Circular saw blades 157
- Circumferential grinding 249
- Clamp-type tool holder 74
- Comparison of old/
 - new material names 377
- Copy turning 54
- Corundum 272
- Counterbores for hexagon socket
 - screws 371
- Counterboring 107, 113
- Countersink 129
- Crater wear 26
- Cutter heads 204
- Cutting edge corner 6
- Cutting edges 5
- Cutting fluids (coolants and lubricants)
 - Dry cutting 352
 - Minimum quantity lubrication 350
 - Wet cutting 349
- Cutting force (see Calculation of force and power)
- Cutting force formation 2
- Cutting force measurement in
 - machining 353
 - Broaching 358
 - Drilling and milling 355
 - Turning 354
- Cutting forces 17
- Cutting materials 43
- Cutting parameters 16
 - Arbour 64
 - Broaching 175
 - Drilling 110
 - Grinding 216
 - Milling 179
 - Planing 96
 - Sawing 147
- Cutting techniques
 - Abrasive belt grinding 297
 - Abrasive cutting 295
 - Broaching 225

- Cylindrical grinding 249
- Drilling 105
- Flat grinding 249
- Honing 301
- Lapping 311
- Milling 173
- Planing 97
- Sawing 147
- Slotting 97
- Superfinishing 309
- Turning 51
- Cutting tips 74
- Cycle time (NC machine tool) 72
- Cylindrical grinding 252
 - between centres 252
 - centerless 255
- Diameter drilled for core holes 367
- Diamond 47
- Diamond tools 47
- Down milling 174
- Drilling into solid 105
- Drilling out 105
- End face driver 64
- End mill cutter 201
- Examples of calculation
 - Broaching 244
 - Drilling 143
 - Grinding 289
 - Milling 217
 - Planing 103
 - Sawing 170
 - Turning 92
- External broaching 225
- Face grinding 250, 267
- Face milling 173
- Facing- and boring head 132
- Failures in
 - Broaching 243
 - Drilling 134
 - Grinding 282
 - Milling 213
 - Sawing 165
 - Turning 84
- Feed 2
- Feed force 15
- Feeding motion 6
- Flat grinding 244
- Form milling 175
- Form turning tool 53
- Fundamentals of machining 5
- Grain sizes 274
- Grinding 249
- Grinding wheel hardness 272
- Grinding wheels 272
- Groove milling 176
- Helical counterbore 127
- Helix angle 192
- High speed cutting (HSC) 325
 - High speed cutting techniques 327
 - High speed machines 328
 - Reference cutting parameters 341
 - Tools for high speed milling 341
- High-speed steel 43
- Holes, grooves, carriers for milling cutters 363
- Honing 301
- Indexable inserts 75
- Influence of angles 8
- Internal broaching 225
- ISO fits 362
- ISO fundamental tolerances 361
- Lapping 311
- Long-thread milling 191
- Machine curve 34
- Machine input power (see Calculation of force and power)
- Machining time for
 - Broaching 232
 - Cylindrical grinding 270
 - Drilling 115
 - Flat grinding 265
 - Milling 188
 - Planing 102
 - Sawing 153
- Major cutting edge 6
- Major machining groups 45
- Milling adaptor 210
- Milling collet 210
- Milling cutter types 196
- Minor cutting edge 6
- Mount pipe 64
- Mounting of cutter heads 205

- New material name 377
Numerical control 56
- On-load speed 363
On-load speeds for machine tools 363
- Parameters and units, formulae vi
Passive force 15
Peak-to-valley height 363
Peripheral milling 173
Plain milling cutter 196
Plunge grinding 253
Polycrystalline cutting materials 323
Power (machine input power) 69
Profile grinding 250, 252
- Rake face 5
Rake face wear 26
Reaming 133
Reference cutting values for
– Broaching 244
– Cylindrical grinding 283
– Drilling 140
– Flat grinding 283
– Milling 214
– Planing 103
– Sawing 165
– Turning 85
Reference planes 6
References 387
- Saw bands 156
Saw blades 156
Shaping 97
Shell end mill 197, 209
Shell end mill arbours 209
Short-stroke honing 309
Side and face milling cutter 198
Silicon carbide 272
Special-shape countersinker 129
Specific cutting force 18, 361
Speed ratio q 257
Speeds 336, 347
Speeds – cutting speeds - diameters 369
Spot facers 129
Superfinishing 309
Surface roughness 58
- Tables 361
Taper turning 53
- Test questions 373
Thread grinding 253
Thread turning 57
Through grinding 261
Through holes for screws 371
Tolerances (see Accuracies – feasible)
Tool clamping devices
– Adaptor sleeve 211
– Clamping chuck 210
– Collet 211
– Milling cutter arbour 208
– Quadruple tool holder 67
– Quick change tool holder 67
Tool curve 33
Tool cutting edge angle 13
Tool cutting edge
 inclination 7
Tool included angle 14
Tool life 25
Tool life curve 28
Tool materials 43
– Abrasive 295
– Cemented carbide 45
– Ceramic 46
– Diamond tools 47
– High-speed steel 43
Tool mountings 334, 335
Tools for
– Abrasive belt grinding 297
– Broaching 234
– Drilling 119
– Grinding 272
– Honing 301
– Lapping 311
– Milling 207
– Reaming 133
– Sawing 155
– Turning 73
Tooth forms (Sawing) 156, 157
Turning technology 51
Turning tools 73
Twist drill 119
- Up milling 173
- Variations for dimensions without tolerance 364
– Tool shanks for milling cutters 369
– Tool shanks with steep taper 368
– Tool tapers 364, 366

Vee-form milling cutter 200
Volume of removed material 39

Wear types 25

Wedge angle 13

Wheel mounting 280

Work-holding chucks

– 3-jaw chuck 6

– Arbour 64

– Collet 63

– Faceplate 60

– Machine table 209

Working angle 11

Working plane 6, 16

Working reference plane 15