

## Introduction to ultra-high-speed optical transmission technology

Hans-Georg Weber<sup>1</sup> and Masataka Nakazawa<sup>2</sup>

<sup>1</sup> Fraunhofer Institute for Telecommunications, Heinrich-Hertz-Institut  
Einsteinufer 37, 10587 Berlin, Germany  
Email: hgweber@hhi.fhg.de

<sup>2</sup> Research Institute of Electrical Communication, Tohoku University  
2-1-1 Katahira, Aoba-ku, Sendai-shi, Miyagi-ken 980-8577, Japan  
Email: nakazawa@riec.tohoku.ac.jp

**Abstract.** This paper serves as an introduction to this volume on ultra-high-speed optical transmission technology. It reviews ultra-high-speed data transmission in optical fibers, which is essentially the same as optical time division multiplexing (OTDM) transmission technology. The research work in this field is driven by the need to increase the transmission capacity and controllability of fiber optic networks as well as by an interest in investigating the feasibility of high-speed data transmission in fiber. The chapter summarizes OTDM components and describes results of OTDM-transmission experiments. In addition, it outlines the chapters of this volume, which describe the considered topics in detail.

### 1. The Challenge of OTDM

The rapid increase in data traffic in communication networks has led to a demand for higher transmission capacities. New fibers may need to be installed from time to time. However, the costs are high and lead times may be long. Therefore, finding a way to increase the fiber transmission capacity is the target of many studies. The transmission capacity per fiber is given by the number of wavelength division multiplexing (WDM) channels multiplied by the time division multiplexing (TDM) bit rate per channel. The past has seen considerable interest in the use of WDM to increase the total transmission capacity. For instance, a 10-Tbit/s transmission capacity was achieved in 2001 using WDM systems with about 260 wavelength channels and a TDM bit rate of 40 Gbit/s [1,2]. However, for very large numbers of wavelength channels (e.g., a few thousand), such factors as wavelength management, power consumption, and footprint will probably limit the usefulness of increasing the number of WDM channels

and will favor a higher TDM bit rate in terms of increasing the total transmission capacity. The motivation for higher TDM bit rates also arises from the effort to reduce the cost per transmitted information bit. A higher TDM bit rate will make it possible to reduce the number of transmitters and receivers and to increase both the spectral and space efficiency of WDM systems. Indeed, in the past the TDM bit rate was steadily increased in installed fiber transmission systems. In the early 1990s and in about 1995, respectively, TDM bit rates of 2.5 and 10 Gbit/s were introduced in commercial fiber transmission systems. This TDM bit rate has now been increased to 40 Gbit/s. These bit rates are all based on electrical signal processing (electrical TDM, ETDM). The next generation TDM bit rate will be 160 Gbit/s. As electrical signal processing is currently unavailable at this bit rate, many laboratories are investigating optical TDM (OTDM) technology. The basics of OTDM technology have been described in several review articles [3–5] and will be discussed below.

The most challenging view as regards OTDM technology is that optical networks will evolve into “photonic networks”, in which ultrafast optical signals of any bit rate and modulation format will be transmitted and processed from end to end without optical-electrical-optical conversion. With this as the target, OTDM technology presents us with the challenge of investigating and developing high-speed optical signal processing and exploring the ultimate capacity for fiber transmission in a single wavelength channel. We must study how the advantages of high TDM bit rates are eventually eroded by an increase in detrimental effects. A higher TDM bit rate makes transmission systems more vulnerable to chromatic dispersion (CD) and polarization-mode dispersion (PMD), as well as creating the need for a higher optical signal-to-noise ratio (OSNR) in the wavelength channel. A higher OSNR is obtained by employing a higher signal power, and this will make the system more sensitive to fiber non-linearity. On the other hand, the need for a high signal power may be reduced by other means such as distributed Raman amplification, advanced optical modulation formats and the use of forward error correction (FEC).

From another viewpoint, OTDM technology is considered to be an interim technique with which to study high-speed data transmission in fiber. In this sense, OTDM will be replaced by ETDM as soon as electrical signal processing becomes available at the required TDM bit rate. This is currently the case with a TDM bit rate of 40 Gbit/s and will probably reach a TDM bit rate of 160 Gbit/s in the future. Recent advances in high-speed electronic ICs based on SiGe technology [6], broadband low drive voltage modulators [7] and waveguide pin detectors [8] indicate that full electronic TDM systems operating at 80 Gbit/s and above are already feasible. For example, an ETDM receiver working at 85 Gbit/s has recently been demonstrated [9]. From this standpoint, the main task as regards OTDM technology is to investigate the feasibility of ultrahigh-speed data transmission as a prerequisite to the development of ETDM technology.

The “photonic network” appears to be a task for the distant future and ETDM technology will dominate commercial transmission systems in the near future. Nevertheless, some OTDM components may find applications in current ETDM systems. Optical pulse sources will be used in ETDM systems with an RZ-modulation format. OTDM demultiplexers already perform better than ETDM receivers at data rates of 80 Gbit/s. We may expect communication networks to be based on an appropriate combination of WDM, ETDM and OTDM technologies. Also, OTDM components, such

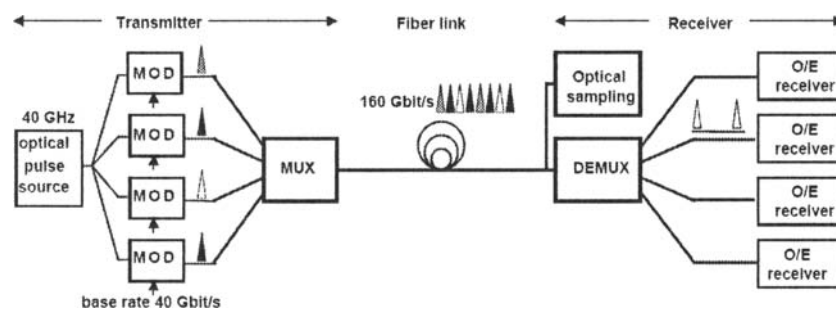

Fig. 1. Schematic view of a 160-Gbit/s OTDM transmission system.

as pulse sources, optical gates and clock recovery devices are already being employed in optical sampling systems for waveform and signal quality monitoring.

## 2. OTDM Transmission System

Figure 1 is a schematic illustration of a 160-Gbit/s OTDM transmission system as an example. The essential component on the transmitter side is an optical pulse source. The repetition frequency of a generated pulse train depends on the base data rate (ETDM data rate). The system shown in Fig. 1 has a base data rate of 40 Gbit/s. The 40-GHz optical pulse train is coupled into four optical branches, in which modulators (MOD) driven by 40 Gbit/s electrical data signals generate 40 Gbit/s optical return to zero (RZ) data signals. The modulation formats include on-off keying (OOK), differential phase shift keying (DPSK), and differential quadrature phase shift keying (DQPSK). The format depends on the modulation format of the electrical data signal and the appropriate modulator. The four optical data signals (TDM channels) are bit-interleaved by a multiplexer (MUX) to generate a multiplexed 160-Gbit/s optical data signal. Multiplexing can be such that all bits of the multiplexed data signal have the same polarization (SP multiplexing) or adjacent bits have alternating (orthogonal) polarization (AP multiplexing). Moreover, the controllability of the optical phases of pulses in adjacent bit slots is an important feature of an OTDM system. On the receiver side, the essential component is an optical demultiplexer (DEMUX), which separates the four base rate data signals (TDM channels) for subsequent detection and electrical signal processing.

The laboratory systems described in this book are frequently simplified on the transmitter side by adopting a set-up with only one modulator, which is combined with a pulse source for a 40-Gbit/s optical transmitter. This optical data signal is then multiplexed by a fiber delay line multiplexer to a 160-Gbit/s data signal using SP or AP multiplexing (see Fig. 2). The laboratory systems described in this book are also frequently simplified on the receiver side. That is, only one 40-Gbit/s TDM channel is selected and detected by one 40-Gbit/s optoelectric receiver at a given time. In a proper experiment all TDM channels are measured successively in this way.

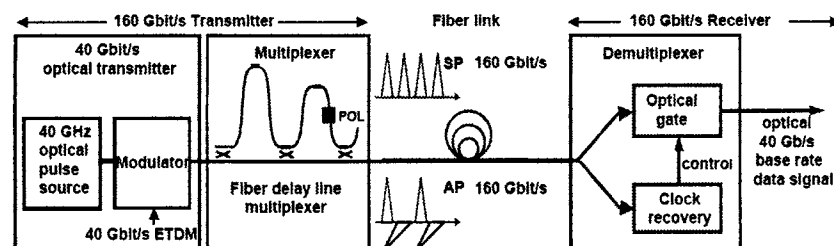

Fig. 2. Schematic view of a simplified 160-Gbit/s OTDM transmission system.

The DEMUX shown in Fig. 2 comprises two parts, an optical gate and a clock recovery device. The optical gate is a fast switch with a switching time that is shorter than the bit period (6.25 ps for 160 Gbit/s) of the multiplexed data signal. The clock recovery device provides the timing signal for the optical gate. Very often in papers on OTDM technology, the DEMUX is identified with the optical gate, and the clock recovery is considered as a separate unit next to the DEMUX.

The transmission system must be capable of compensating for chromatic dispersion (CD) and polarization mode dispersion (PMD), which both depend on the type of single-mode fiber used in the transmission system. For advanced high-speed transmission systems, it is desirable to employ techniques such as optical sampling to monitor the optical data signal with picosecond resolution. Chapter 17 (“Optical sampling techniques”, by Schmidt-Langhorst and Weber) reviews the techniques used in optical sampling systems to perform the ultrafast sampling of the signal under investigation.

For even more advanced systems, high-speed optical signal processing techniques must be developed not only for the point-to-point transmission shown in Fig. 1, but also for transmission nodes. Components and subsystems such as add-drop multiplexers [e.g., 10–13], wavelength converters [e.g., 14–17], modulation format converters [e.g., 18] and optical regenerators [e.g., 19,20] are also required. These topics are partly dealt with in chapter 6 (“Optical signal processing using nonlinear fibers”, by Watanabe) in the context of fiber-based optical signal processing and in chapters 5 (“High-speed optical signal processing using semiconductor optical amplifiers”, by Schubert et al.) and 8 (“Optical nonlinearities in semiconductor optical amplifier and electro-absorption modulator: their applications to all-optical regeneration”, by Usami and Nishimura) in the context of semiconductor optical amplifier and electroabsorption modulator based optical signal processing.

Figures 1 and 2 show the set-up of a one wavelength channel OTDM system. Chapters 13 (“Application of electroabsorption modulators for high-speed transmission systems”, by Lach et al.) and 15 (“Ultrafast optical technologies for large-capacity TDM/WDM photonic networks”, by Morioka) also provide examples of WDM/OTDM transmission systems comprising several wavelength channels.

### 3. Transmitter: Optical Pulse Source, Modulator, Multiplexer

High bit rate transmission demands reliable short pulse generation at high repetition frequencies. The pulse source must provide the following: a well-controlled repetition frequency and wavelength, transform limited pulses, a pulse width shorter than the bit period of the multiplexed data signal, a timing jitter much less than the pulse width, low amplitude noise, and a high extinction ratio (pedestal suppression). The pulse width should be less than one quarter of the bit period (1.5 ps for 160 Gbit/s) for SP multiplexing and less than one half of the bit period for AP multiplexing to avoid coherent beat noise between adjacent bits. Moreover, if some sort of phase modulation format such as a DPSK is used, there are further pulse source requirements, namely it must be highly stable in terms of phase and carrier wavelength.

Various pulse sources were used in the OTDM transmission experiments. Semiconductor mode-locked lasers (ML-LD) are becoming increasingly attractive, as they are stable, compact and viable for OTDM applications. In chapter 2 (“Semiconductor mode-locked lasers as pulse sources for high bit rate data transmission”, by Jiang et al.), the ML-LD is evaluated as a pulse source for high bit rate data transmission. This chapter compares various OTDM source technologies, explains the impact of timing jitter and amplitude noise on OTDM performance, and illustrates how to characterize OTDM source noise. Another important pulse source is the mode-locked fiber ring laser (ML-FRL). Chapter 3 (“Ultrafast mode-locked fiber lasers for high-speed OTDM transmission and related topics”, by Nakazawa) provides a detailed description of several types of ML-FRL, which are capable of generating picosecond to femtosecond optical pulse trains at repetition rates of 10 to 40 GHz in the 1.55  $\mu\text{m}$  region. The ML-FRL is a harmonically mode-locked laser, whereas the ML-LD is generally operated at the fundamental mode repetition frequency. Recently, a solid-state mode-locked laser, known as an erbium-glass oscillator pulse generating laser (ERGO-PGL), was successfully operated in a 160 Gbit/s transmission experiment [12]. This laser operates at the fundamental mode repetition frequency. It has very low amplitude and phase noise and a pulse width that is slightly larger than those of the ML-LD and ML-FRL.

Another pulse source is a CW laser externally modulated (CW-Mod) by a Mach-Zehnder modulator or an electroabsorption modulator (EAM). The application of this pulse source in 160 and 320 Gbit/s (AP multiplexing) OTDM transmission experiments is described in chapter 13 (“Application of electroabsorption modulators for high-speed transmission systems”, by Lach et al.). In general this type of pulse source does not provide optical pulses with a pulse width of less than about 3 ps. Some sort of subsequent pulse compression (PuC) and optical regeneration are needed to generate shorter pulses.

A pulse source of particular interest for WDM/OTDM applications is the super-continuum pulse generation (SC-pulse) described in chapter 15 (“Ultrafast optical technologies for large-capacity TDM/WDM photonic networks”, by Morioka). This pulse source provides short (<1 ps) optical pulses, whose pulse width and wavelength are both tunable. Moreover, this pulse source can be used as a multi-wavelength pulse source for WDM/OTDM systems.

The generated pulse train is modulated by using an EAM or a lithium-niobate ( $\text{LiNbO}_3$ ) modulator. Chapter 4 (“Ultra-high-speed  $\text{LiNbO}_3$  modulators”, by Noguchi) discusses state of the art ultrahigh-speed  $\text{LiNbO}_3$  modulators. The  $\text{LiNbO}_3$  modulator covers a very broad band. Moreover, its modulation characteristics, such as insertion

loss, driving voltage (half-wave voltage), and frequency response, have little dependence on wavelength in the 1.3 to 1.5  $\mu\text{m}$  range. In addition, the frequency chirping of a modulated optical signal can be reduced to almost zero.  $\text{LiNbO}_3$  modulators have been used as amplitude and phase modulators in many high bit rate transmission experiments. Chapter 13 (“Application of electroabsorption modulators for high-speed transmission systems”, by Lach et al.) describes the application of the EAM in OTDM experiments for data modulation as well as pulse carving, and this chapter also compares the EAM and the  $\text{LiNbO}_3$  modulator.

Most optical multiplexers (MUX) are of the kind depicted in Fig. 2. They are realized by using  $2 \times 2$  optical couplers and optical delay lines either as fiber devices or as planar lightwave circuits. These multiplexers are not “real” multiplexers, which combine TDM channels generated, for example, by different modulators (see Fig. 1) to provide a multiplexed data signal. The delay line multiplexers generate a high bit rate test signal for laboratory experiments by combining several replicas of one data signals with different relative delays. An important requirement for these “test multiplexers” is that there is no correlation between the adjacent bits of the multiplexed data signal. This is obtained by employing a delay time, which is long compared with the bit period of the input signal. These test multiplexers are described in more detail in chapter 13 (“Application of electroabsorption modulators for high-speed transmission systems”, by Lach et al.). An example of a “real” multiplexer is provided in chapter 15 (“Ultrafast optical technologies for large-capacity TDM/WDM photonic networks”, by Morioka). This multiplexer enables the multiplexing of eight different 20 Gbit/s data signals to one multiplexed 160 Gbit/s data signal by using an integrated planar lightwave circuit [21, 22]. Yet another “real” multiplexer is reported in [23] and described in chapter 13 (“Application of electroabsorption modulators for high-speed transmission systems”, by Lach et al.). It provides independent modulation of all TDM-channels and optical phase alignment between adjacent bits.

#### **4. OTDM-Receiver: Optical Demultiplexer, Clock Recovery Device, O/E-Receiver**

Various switching devices have been used for demultiplexing. In very high-speed transmission experiments, optical switching was based on fiber nonlinearity using cross phase modulation (XPM) or four wave mixing (FWM) in fibers [3–5]. A well-known example is the nonlinear optical loop mirror (NOLM) [24]. Chapter 14 (“Ultrafast OTDM transmission using novel fiber devices for pulse compression, shaping, and demultiplexing”, by Yamamoto and Nakazawa) describes the application of the NOLM as a DEMUX for a data rate of 640 Gbit/s, the fastest DEMUX reported so far. The advantage of fiber based switching devices is their potential for ultrafast switching due to the fast non-resonant nonlinearity of the fiber. The main drawback of these devices stems from the small optical nonlinearity of glass. For an optical switch, the product of control power times the fiber length of conventional fiber must be about 1 W km. In recent years, however, new fibers have been developed called “highly non-linear fibers” (HNLF). At present, the product of control power times fibre length of HNLF needs only to be about 0.1 W km mainly because of the smaller effective area of the HNLF. Chapter 6 (“Optical signal processing using nonlinear fibers”, by Watanabe) reports on all-optical signal processing using HNLF for demultiplexing and other ap-

plications. Another type of new optical fiber is the photonic crystal fiber [25]. Optical signal processing based on photonic crystal fiber is not explicitly reported in this book.

Another class of optical switching devices uses the high resonant nonlinearity in active semiconductor structures. Chapter 5 (“High-speed optical signal processing using semiconductor optical amplifiers”, by Schubert et al.) reports on optical gating devices based on XPM and FWM in a semiconductor optical amplifier (SOA). Examples of XPM based optical gates include the SOA in a Mach-Zehnder interferometer (SOA-MZI), the SOA in a polarization discriminating switch (SOA-UNI), and the SOA in a Sagnac interferometer (SLALOM). These devices have been used as DEMUX in several high-speed transmission experiments. Examples are the SOA-MZI DEMUX in transmission experiments at bit rates of up to 320 Gbit/s [26,27], and the SLALOM DEMUX in a 640-Gbit/s demultiplexing experiment, where 8 WDM channels, each carrying an 80-Gbit/s TDM data signal, were simultaneously demultiplexed in the time domain to 8 further WDM channels, each carrying a 10-Gbit/s TDM data signal [28]. The advantage of the SOA based switching devices is their small size and their low optical power requirement for all-optical switching. Moreover, these devices can be realized as photonic integrated circuits.

SOA- and fiber-based optical gates use all-optical switching. An optical signal controls the gate, which switches an optical data signal. Another optical gate used in many high-speed transmission experiments is the electroabsorption modulator (EAM). In this device an electrical control signal controls the gate that switches the optical data signal. This switch has been used for demultiplexing in many transmission experiments as described in chapter 13 (“Application of electroabsorption modulators for high-speed transmission systems”, by Lach et al.). Recently, an EAM was monolithically integrated with a photodiode and an electrical signal from the photodiode drove the EAM directly [29, 30].

The demultiplexers described above are capable of selecting only one TDM channel of the multiplexed data signal (single channel output operation). Multiple channel output operation can be achieved by a serial-parallel configuration of several of these switches. An example is reported in [31] and discussed in chapter 15 (“Ultrafast optical technologies for large-capacity TDM/WDM photonic networks”, by Morioka). This chapter also reports on the realization of optical switches that provide a multiple channel output directly in a single device. The reported examples utilize XPM-assisted chirp compensation in an optical fiber or FWM by employing linearly chirped square control pulses to generate different frequency components corresponding to independent TDM channels.

SOA- and EAM-based optical switching devices operate well at data rates of up to 160 Gbit/s. Their performance worsens considerably at higher data rates. Chapter 16 (“New optical device technologies for ultrafast OTDM systems”, by Sakurai and Kobayashi) reports on investigations into new optical device technologies, which will enable faster switching devices to be realized for future ultrafast OTDM transmission systems.

Clock recovery or timing extraction from a transmitted data signal is another key function in an OTDM receiver and in other subsystems such as add-drop multiplexers and 3R-regenerators. Several timing extraction techniques have been developed including phase-locked loops (PLL), the injection locking of pulse sources, and resonant oscillator circuits [4,5]. At data rates of 160 Gbit/s and beyond, clock recovery was most successfully achieved by using PLL configurations with an optical or opto-

electrical phase comparator. Chapters 5 (“High-speed optical signal processing using semiconductor optical amplifiers”, by Schubert et al.) and 15 (“Ultrafast optical technologies for large-capacity TDM/WDM photonic networks”, by Morioka) report on the application of SOAs as optical phase comparators using either FWM or XPM in an SOA and chapter 13 (“Application of electroabsorption modulators for high-speed transmission systems”, by Lach et al.) reports on the application of EAMs as optoelectrical phase comparators in a clock recovery circuit. SOA-based and EAM-based clock recovery devices have been operated at up to 400 [32] and 320 Gbit/s [33], respectively.

Many transmission experiments were also performed without recovering the clock signal from the multiplexed data signal, because an appropriate clock recovery device was unavailable. Two alternative approaches were used. A clock signal was generated at the transmitter and transmitted together with the data signal over the fiber at a separate wavelength (“clock transmitted”), or the multiplexer at the transmitter end was adjusted for slightly different pulse amplitudes (“clock modulation”) such that a simple photo detector was able to detect the clock signal at the receiver end.

In the OTDM experiments reported to date, the O/E receivers were operated at up to 40 Gbit/s. However, in laboratory experiments O/E receivers have already operated at data rates of up to about 80 Gbit/s [9]. Chapter 7 (“Ultrafast photodetectors and receivers”, by Bach) reports on ultrafast photodetectors and receivers. It is expected that ETDM transmission systems will soon be available for data rates up to 100 Gbit/s. This will most likely increase the base rate of OTDM systems from 40 to 100 Gbit/s.

## 5. Transmission Fiber, Compensation of Chromatic Dispersion and Polarization Mode Dispersion, 2R/3R-Regeneration

A data signal is degraded along a transmission line by attenuation, fiber non-linearity, chromatic dispersion (CD) and the polarization mode dispersion (PMD) of the fiber, and the accumulation of noise generated in the amplifier stages. These impairments can be partly compensated for, depending on the type of transmission fiber used.

For a 160-Gbit/s system, it is necessary to compensate not only for chromatic dispersion ( $D$  or  $\beta_2$ ) at the center wavelength of the pulse but also for the dispersion slope ( $dD/d\lambda$  or  $\beta_3$ ). The dispersion slope produces oscillations near the trailing edge of the data pulse even if the center wavelength of the pulse is adjusted to the zero-dispersion point of the path-averaged dispersion. Currently, the most mature dispersion compensation technique is based on dispersion compensating fibres (DCF), which compensate simultaneously for both  $D$  and  $dD/d\lambda$ . DCF, also sometimes known as high-slope dispersion compensating fiber (HS-DCF), has become an essential optical component supporting high-speed large capacity optical transmission. DCF has further evolved into dispersion-managed optical fiber transmission lines. Chapter 9 (“Optical fibers and fiber dispersion compensators for high-speed optical communication”, by Nishimura) reports on DCF and dispersion-managed optical transmission lines as well as on advanced optical fiber such as ultra-low loss or ultra-low nonlinearity fiber and various types of dispersion-modified fiber.

Dispersion compensation using DCF is insufficient for very high bit rate transmission (640 Gbit/s and beyond) in most fibers. Higher order dispersion terms ( $\beta_4$ ) have to be taken into account. This is dealt with in chapter 11 (“Higher-order dispersion compensation using phase modulators”, by Pelosi and Suzuki). This chapter focuses



on the use of a phase modulation technique that has been effectively employed in the fastest OTDM fiber transmission experiments using OOK modulation format reported to date [see chapter 14 (“Ultrafast OTDM transmission using novel fiber devices for pulse compression, shaping, and demultiplexing”, by Yamamoto and Nakazawa)].

Various types of transmission fiber and their associated DCF have been investigated for high-speed data transmission. Examples are standard single-mode fiber (SMF,  $D \cong 17$  ps/km/nm at  $\lambda = 1550$  nm), dispersion shifted fiber (DSF,  $D \cong 0.1$  ps/km/nm), and various types of non-zero dispersion shifted fiber (NZDSF,  $D \cong 4\text{--}8$  ps/km/nm), e.g., TrueWave<sup>TM</sup>, LEAF<sup>TM</sup> and TeraLight<sup>TM</sup>. Additionally, there are several types of dispersion-managed fiber (DMF) such as “TeraLight<sup>TM</sup>-Reverse TeraLight<sup>TM</sup>”, SMF-reverse dispersion fiber (SMF-RDF) and “Ultrawave<sup>TM</sup> Fiber” (SLA-IDF). The DMF represents a pair of transmission fibers, which together compensate for  $D$  and  $dD/d\lambda$  over a wide wavelength range. For example Ultrawave<sup>TM</sup> Fiber comprises Super Large Area fiber (SLA,  $D \cong 20$  ps/km/nm) and Inverse Dispersion Fiber (IDF,  $D \cong -44$  ps/km/nm).

The tolerances as regards residual dispersion or residual DCF length are particularly crucial for high-speed systems. For instance, for a data rate of 160 Gbit/s over 160 km of SMF, the 3 dB tolerance (an increase in the pulse width by a factor of two) is  $\pm 1.2$  ps/nm. This corresponds to a DCF fiber length tolerance of  $\pm 12$  m or an SMF fiber length tolerance of  $\pm 75$  m. To maintain such small tolerances over a large environmental temperature range requires automatic dispersion compensation in addition to the DCF fiber. Various tunable dispersion compensators have been proposed [34–37]. In particular, the chirped fiber Bragg grating (FBG) is a key device for tunable dispersion compensation. Chapter 10 (“Fiber Bragg gratings for dispersion compensation in optical communication systems”, by Sumetsky and Eggleton) presents an overview of FBG fabrication principles and applications with emphasis on the chirped FBG used for dispersion compensation in high-speed optical communication systems. An example of a tunable dispersion compensator is also discussed in chapter 15 (“Ultrafast optical technologies for large-capacity TDM/WDM photonic networks”, by Morioka).

High-speed transmission experiments are commonly performed in the quasi-linear (pseudo-linear) transmission regime, where the nonlinear length is much greater than the dispersion length [e.g., 38]. A high local dispersion is advantageous for this transmission regime, provided that the path-averaged dispersion and dispersion slope are close to zero. The short pulses of the data signal disperse very quickly in the fiber, spreading into many adjacent timeslots before the original pulse sequence is restored by dispersion compensation. Therefore, the peak power of the pulses is low for most of the path along the fiber. Consequently, fibers with high dispersion  $D$  are most appropriate for high-speed transmission. For example, with 160 Gbit/s data transmission, impressive results with transmission spans of up to 2,000 km have been obtained using NZDSF [39]. However, 160 Gbit/s data transmission over the Ultrawave<sup>TM</sup> Fiber with its high local dispersion and low non-linearity achieved a transmission distance of more than 4,000 km [40]. In these experiments, intra-channel FWM is the main degradation factor as regards data signals with high optical powers.

PMD is also a severe limitation with respect to high bit rate data transmission. PMD is caused by a slight birefringence of the fiber and of other components in the transmission link. Based on the example cited above, a PMD value of less than 0.07 ps/ $\sqrt{\text{km}}$  is needed to realize a low penalty 160 Gbit/s transmission over a 160-km fiber link. Modern fiber such as Ultrawave<sup>TM</sup> Fiber has a PMD value of less than 0.05

Table 1. Examples of ultra-high-speed optical transmission experiments.

Date	TDM bit rate (Gbit/s)	WDM channel	Modulation format	Transmission length (km, fiber)	Span length (km, repeater)	Pulse source	Demux	Recovery	Institute	Ref.
03/95	160	1	OOK, AP	200 DSF	25, EDFA	ML-FRL+PuC	POL+NOLM	clock modulation	NTT	46
05/95	200	1	OOK, SP	100 DSF	20, 40, EDFA	SC-pulse	FWM in Fiber	PLL, FWM in SOA	NTT	47
05/96	400	1	OOK, SP	40 SMF	unrepeated	SC-pulse	FWM in Fiber	PLL, FWM in SOA	NTT	48
09/97	200	7	OOK, SP	50 DSF	unrepeated	SC-pulse	FWM in Fiber	PLL, FWM in SOA	NTT	52
04/98	640	1	OOK, SP	60 SMF	unrepeated	ML-FRL+PuC	NOLM	clock modulation	NTT	49
05/99	160	19	OOK, SP	40 DSF	unrepeated	SC-pulse	FWM in Fiber	PLL, FWM in SOA	NTT	53
09/99	160	1	OOK, AP	300 TW	100, EDFA	CW+Mod+PuC	2 EAM	resonant-oscillator	Lucent	61
03/00	320	1	OOK, AP	200 TW	100, Raman	CW + Mod	POL+2 EAM	resonant-oscillator	Lucent	38
09/00	160	1	OOK, SP	160 SMF	unrepeated	ML-LD	SOA-MZI	transmitted	HHI	54
11/00	1280	1	OOK, AP	70 SMF +RDF	unrepeated	ML-FRL+PuC	POL+NOLM	transmitted	NTT	51
03/01	160	6	OOK, AP	400 TW	100, Raman	SC-pulse	2 EAM	resonant-oscillator	Lucent	67
03/01	160	1	OOK, SP	116 SMF, field trial	unrepeated	ML-LD	SOA-UNI	transmitted	HHI	55
09/01	160	1	OOK, SP	200 TW-RS, LEAF	unrepeated	CW+Mod+PuC	3 EAM	resonant-oscillator	Agere	62
08/03	160	4	OOK, AP, CS-RZ	225 NZ-DSF	75, EDFA	CW + Mod	POL+2 EAM	resonant-oscillator	KDDI	71
09/03	160	1	OOK, SP, CS-RZ	640 SMF	80, Raman	CW + Mod	2 EAM	PLL	OKI	23
09/03	160	8	OOK, AP, CS-RZ	85 TerraLight-Ultra	unrepeated	CW + Mod	1 EAM +POL	resonant-oscillator	Alcatel	69
09/03	160+7%FEC	7	OOK, AP, CS-RZ	600 SMF	100, Raman	CW + Mod	1 EAM +POL	transmitted	Alcatel	70
09/03	160	8	OOK, SP	140 SMF	unrepeated	SC-pulse	SOA-MZI	transmitted	FESTA /OKI/NEC	57
10/03	160	1	DPSK, SP	410, SLA+IDF	80, EDFA	ML-LD	1 EAM	EO-PLL, EAM	HHI	75
11/03	160+7%FEC	6	DPSK, AP	2000 TW-RS	100, Raman	CW + Mod	1 EAM, 40Gbps	clock modulation	Lucent	39
02/04	160	1	OOK, SP	160, SMF+RDF	80, Raman	SC-pulse	all channel	transmitted	NTT/ Stanford Univ.	22
07/04	160	1	DPSK, SP	200 SMF, field trial	50, EDFA	CW+Mod+PuC	2 EAM, 40Gbps	EO-PLL, EAM	KDDI/ NICT	77
09/04	160	1	OOK, SP	275 SMF, field trial	69, EDFA	solid state	FWM in SOA	EO-PLL, EAM	Siemens/ BT	58
09/04	160+7%FEC	8	OOK, AP, CS-RZ	430 SMF, field trial	71, EDFA	CW + Mod	1 EAM +Pol	resonant-oscillator	Alcatel/ FT/ DT	45
09/04	320	10	OOK, SP	40, SMF	unrepeated	SC-pulse	SOA-MZI	transmitted	FESTA /OKI/NEC	26
09/04	640	1	DPSK, AP	160 SLA+IDF	80, EDFA	ML-FRL	POL+NOLM	EO-PLL, EAM	HHI / Fujitsu	80
09/05	160+7%FEC	1	DPSK, AP	4300 SLA+IDF	80, Raman	ML-LD	1 EAM, 40Gbps	EO-PLL, EAM	HHI/ Lucent(G)	40
09/05	640	1	DQPSK, AP	480 SLA+IDF	80, EDFA	ML-LD	POL+ 1 EAM	EO-PLL, EAM	HHI	84
02/06	1280	1	DQPSK, AP	240 SLA+IDF	80, EDFA	solid state	POL+NOLM	EO-PLL, EAM	HHI/Fujitsu	85
02/06	2400+7%FEC	1	DQPSK, AP	160 SLA+IDF	80, EDFA	solid state	POL+NOLM	clock modul.+PLL	HHI/Fujitsu	85

ps/ $\sqrt{\text{km}}$ . On the other hand, older installed fiber generally has a larger PMD value. Unlike CD, PMD is much more difficult to compensate for because it changes greatly with time and wavelength in a non-deterministic way. Therefore, automatic (adaptive) PMD compensation is required. Chapter 12 (“PMD-compensation techniques”, by Rosenfeldt and Brinkmeyer) deals with PMD compensation techniques. Adaptive PMD compensation has been demonstrated for data rates of up to 160 Gbit/s [41–45]. In most ultrahigh bit rate transmission experiments, PMD (first order) was compensated for by manually adjusting the polarization of the data signal at the transmission link input.

For advanced transmission systems, 3R-regeneration (re-amplification, re-shaping, re-timing) is needed to reduce the transmission impairments, which are associated with waveform distortions caused by fiber transmission as well as with noise and jitter accumulation. There has been little experimental work on this topic as regards high bit rate data transmission. Chapter 6 (“Optical signal processing using nonlinear fibers”, by Watanabe) reports on a 160-Gbit/s 3R-regenerator experiment [19]. Chapter 8 (“Optical nonlinearities in semiconductor optical amplifier and electro-absorption modulator: their applications to all-optical regeneration”, by Usami and Nishimura) provides some references to 2R and 3R regenerator experiments for data rates below 160 Gbit/s.

## 6. Transmission Experiments

In this review we focus on the recent developments with respect to OTDM transmission experiments as early transmission experiments have been discussed in previous review articles [3–5]. Table 1 is a summary of important and recent high bit rate transmission experiments at TDM bit rates of 160 Gbit/s and beyond. Many of the pioneering OTDM-transmission experiments were performed by NTT and are described in chapter 15 (“Ultrafast optical technologies for large-capacity TDM/WDM photonic networks”, by Morioka). Examples include 160 Gbit/s soliton transmission over 200 km DSF [46], 200 Gbit/s transmission over 100 km DSF [47], 400 Gbit/s over 40 km SMF [48], 640 Gbit/s over 60 km and 92 km SMF [49,50] and finally 1.28 Tbit/s over 70 km DMF (SMF+RDF) [51]. In addition to these single wavelength channel transmission experiments, chapter 15 (“Ultrafast optical technologies for large-capacity TDM/WDM photonic networks”, by Morioka) also describes pioneering OTDM/WDM experiments performed by NTT such as 1.4 Tbit/s (200 Gbit/s  $\times$  7  $\lambda$ ) over 50 km DSF [52] and 3 Tbit/s (160 Gbit/s  $\times$  19  $\lambda$ ) over 40 km DSF [53]. These experiments combine ultrafast OTDM and ultra-wideband WDM technologies.

In these experiments, the terminal equipment mainly comprised fiber devices. The pulse source in the transmitter was either a mode-locked fiber ring laser (ML-FRL) followed by an optical pulse compressor (PuC) or a pulse source based on supercontinuum generation (SC-pulse). The demultiplexer in the OTDM-receiver was an optical gate based either on a nonlinear optical loop mirror (NOLM) or on four-wave-mixing (FWM) in fiber. An exception was the optical clock recovery device, which comprised a PLL with a phase comparator based on FWM in a semiconductor optical amplifier (SOA). EDFAs were used as in-line amplifiers.

The NTT work represents investigations on the physical limits of high-speed fiber transmission and the search for appropriate data generation, transmission and demultiplexing techniques to extend these limits. An extraordinary 1.28 Tbit/s (640 Gbit/s  $\times$

2 polarization-division multiplexing) single wavelength channel transmission experiment is described in detail in chapter 14 (“Ultrafast OTDM transmission using novel fiber devices for pulse compression, shaping, and demultiplexing”, by Yamamoto and Nakazawa). This chapter covers the adiabatic soliton compression technique, which compresses the optical pulses of an ML-FRL, a technique for eliminating the pedestals of the compressed optical pulses, and an all-optical demultiplexing technique employing a NOLM with very small walk-off.

An alternative to fiber-based optical signal processing is the employment of semiconductor devices for optical signal processing in the transmitter and receiver of the OTDM system. In particular, the SOA has long been considered a key device for optical signal processing. Chapter 5 (“High-speed optical signal processing using semiconductor optical amplifiers”, by Schubert et al.) describes the technology of SOA-based devices such as optical gates, optical clock recovery devices and optical add-drop multiplexers. These devices have been used in several transmission experiments [54–58,26,12,22]. Examples of single wavelength channel transmission include unrepeated 160 Gbit/s transmission over 160 km SMF using a hybrid SOA-MZI DEMUX [54], the first 160-Gbit/s field trial involving unrepeated transmission over 116 km field-installed SMF using an SOA-UNI DEMUX [55] and a 160 Gbit/s field trial over various link lengths of installed fiber of up to 275 km SMF using a DEMUX based on FWM in a SOA [58,12]. The latter field experiment is of particular interest because it also includes a 160 Gbit/s add-drop node based on gain-transparent operation of a SOA [see chapter 5 (“High-speed optical signal processing using semiconductor optical amplifiers”, by Schubert et al.)]. This is the first OTDM networking experiment using deployed fiber. Also of particular importance is the first 160 Gbit/s OTDM transmission experiment with all-channel independent modulation and all-channel simultaneous demultiplexing achieved by using a multiplexer and a demultiplexer based on periodically poled lithium niobate and SOA hybrid integrated planar lightwave circuits [22]. This transmission experiment is described in detail in chapter 15 (“Ultrafast optical technologies for large-capacity TDM/WDM photonic networks”, by Morioka). A hybrid-integrated SOA-MZI DEMUX was operated in two OTDM/WDM transmission experiments, namely, 1.28 Tbit/s ( $160 \text{ Gbit/s} \times 8\lambda$ ) unrepeated transmission over 140 km SMF [57] and 3.2 Tbit/s ( $320 \text{ Gbit/s} \times 10\lambda$ ) transmission over 40 km SMF [26]. In these experiments the spectral efficiencies were 0.4 and 0.8 bit/s/Hz, respectively.

At present, the SOA based optical gate is probably not the most popular choice for demultiplexing applications in 160 Gbit/s transmission systems. Another semiconductor device, the EAM, has been developed into a very effective component for optical signal processing. In pioneering experiments, British Telecom (BT) demonstrated the application of the EAM for OTDM data generation and demultiplexing [59,60]. Lucent Technologies reported the first 160 Gbit/s transmission experiment, which used the EAM as a key device in the transmitter and the receiver [61]. This investigation also stimulated similar experiments in many other laboratories [62–65], because 160 Gbit/s transmission became viable without such sophisticated devices for demultiplexing as interferometric optical gates or FWM configurations based on SOAs or fibers, and without sophisticated optical pulse sources. The EAM was used as an optical gate in the demultiplexer, as a basic element in the clock recovery circuit and as a device for optical pulse generation (CW + Mod). Moreover, the EAM-based demultiplexer is polarization insensitive, which is difficult to achieve with the fiber-

based and SOA-based demultiplexers. Also, the EAM-based demultiplexer does not need an optical pulse source to operate the optical gate. The simpler technology of the EAM-based OTDM-system also stimulated 320 Gbit/s transmission experiments using AP-multiplexing [66,38] and several  $N \times 160$  Gbit/s OTDM/WDM transmission experiments [67–71,45]. Chapter 13 (“Application of electroabsorption modulators for high-speed transmission systems”, by Lach et al.) focuses on OTDM transmission technology based on EAMs. This chapter reviews the various applications of the EAM in the transmitter and receiver in ultra-high speed OTDM-transmission systems and also presents the results of single channel and WDM/OTDM fiber transmission experiments.

In the experiments mentioned above, the modulation format was on-off-keying (OOK). Moreover, in most of these experiments the relative phase of adjacent pulses (RZ-signals) was arbitrary, because in general no effort was made in these experiments to adjust and stabilize the delay line multiplexers for a well-defined relative phase of the adjacent pulses. However, the controllability of the optical phase alignment between adjacent bits is an important feature of an OTDM system [72]. The effect of a well-defined relative phase of adjacent data pulses in the multiplexed data signal is expected to increase the tolerance of the transmission system with respect to CD and fiber nonlinearity and it will increase the spectral efficiency. Techniques for realizing optical phase alignment have been introduced [73,74] and several OTDM and OTDM/WDM transmission experiments have been performed using such formats as “carrier-suppressed return-to-zero (CS-RZ)”, in which the optical pulses in adjacent bit slots have a relative phase shift of  $\pi$  [23,69–71,45].

Recently, several OTDM-transmission experiments have been performed using modulation format differential phase shift keying (DPSK) [75–80, 39,40]. In combination with balanced detection, 160 Gbit/s DPSK transmission provided a system performance that was more than 3 dB better than transmission with the OOK modulation format [76]. The increased system margin can be used to extend the transmission length or to reduce the optical power requirements. On the other hand, additional components are needed in the transmitter and receiver. In particular, the DPSK demodulator in the receiver needs to be actively matched to the transmitter wavelength, which increases the system complexity. Nevertheless, the improvement in the system performance is significant and worth the additional system cost and complexity. The increased system margin also made it possible to realize a 640-Gbit/s DPSK, AP transmission over a 160 km dispersion managed fiber link [80].

In the past, many high-bit-rate transmission experiments were “proof of feasibility” experiments. It was sufficient simply to obtain a system that was stable for the few minutes needed to perform BER measurements. Recently, it was also shown that OTDM transmission systems can have long-term stability [78,79]. In a 160-Gbit/s DPSK transmission over a 320-km fiber link, BER measurements revealed, that the system operated without any error for more than 5 hours. This corresponds to a BER of about  $10^{-15}$ . The first errors were detected after 5 hours and these were caused by a slight drifting of some parts of the system with increases in the environmental temperature. There were 32 errors within 10 hours. After 10 hours the system was readjusted and error-free performance was again obtained. No PMD compensator was required in this experiment because of the high quality of the Ultrawave™ Fiber used. Similar results were also obtained using a 334-km SMF fiber link including a PMD mitigation scheme [79]. In both experiments, the transmission system comprised a

semiconductor mode-locked laser (ML-LD) in the transmitter and two EAMs in the demultiplexer (one in the optical gate and one in the clock recovery). If this system is equipped with an automatic stabilization circuit and FEC, it can probably be operated error free for many years. The system has a stability appropriate for applications in a deployed transmission link.

Some further recent transmission experiments concern DQPSK transmission with data rates of 160 Gbit/s and higher [82-85]. DQPSK transmission provides a bit rate that is twice the symbol bit rate. Based on 40 Gbit/s ETDM technology, the application of DQPSK provides 80 Gbit/s data transmission. In [82,83] this was further combined with polarization-division multiplexing (AP multiplexing) to generate a 160-Gbit/s data signal. In this experiment, 40 WDM channels, each carrying a 160 Gbit/s data signal generated in this way, were transmitted over a 324-km SMF fiber link. The system was operated above the FEC limit. This corresponds to a 5.94-Tbit/s error-free transmission conditional on the use of FEC. A spectral efficiency of 1.6 bit/s/Hz was obtained. In another experiment, the 160-Gbit/s OTDM-SP-multiplexing transmission technology was upgraded to 640 Gbit/s by applying the modulation format DQPSK and polarization-division multiplexing (AP multiplexing). A 640-Gbit/s DQPSK data signal was transmitted over 480 km DMF (SLA-IDF) error-free without FEC [84].

Most recently, DQPSK transmission with AP multiplexing was also realized at 1.28 Tbit/s over 240 km and 2.56 Tbit/s over 160 km fiber link [85]. For 1.28 Tbit/s, error-free ( $\text{BER} < 10^{-9}$ ) transmission was obtained for all tributaries of the 1.28 Tbit/s data signal. For 2.56 Tbit/s transmission, the system performed nearly error-free ( $\text{BER} \approx 10^{-9}$ ) in the back-to-back configuration and revealed BER-values  $\leq 10^{-5}$  after 160 km transmission. BER values of less than  $10^{-4}$  result in an effective BER  $< 10^{-12}$  if standard FEC (assuming a 7% overhead) is used. This FEC would reduce the payload to 2.4 Tbit/s.

## References

1. K. Fukuchi, T. Kasamatsu, M. Morie, R. Ohhira, T. Ito, K. Sekiya, D. Ogasahara, and T. Ono, "10.92 Tb/s ( $273 \times 40$  Gb/s) triple-band/ultra-dense WDM optical-repeated transmission experiment" in Proc. Optical Fiber Communication Conference, OFC 2001, postdeadline papers, PD 24 (2001).
2. S. Biego, Y. Frignac, G. Charlet, W. Idler, S. Borne, H. Gross, R. Dischler, W. Poehlmann, P. Tran, C. Simonneau, D. Bayart, G. Veith, A. Jourdan, J.-P. Hamaide, "10.2 Tbit/s ( $256 \times 42.7$  Gbit/s PDM/WDM) transmission over 100 km TeraLight fiber with 1.28 bit/s/Hz spectral efficiency" in Proc. Optical Fiber Communication Conference, OFC 2001, postdeadline papers, PD 25 (2001).
3. S. Kawanishi, "Ultrahigh-speed optical time-division-multiplexed transmission technology based on optical signal processing", IEEE J. Quantum Electron. **34**, 2064-2079 (1998).
4. M. Saruwatari, "All-optical signal processing for Tera bit/s optical transmission", IEEE J. Select Topics Quantum Electron. **6**, 1363-1374 (2000).
5. M. Saruwatari, "All-optical time-division multiplexing technology" in *Fiber Optic Communication Devices*, edited by N. Grote, H. Venghaus (Springer-Verlag, Berlin, 2001).
6. A. Joseph, D. Coolbaugh, D. Haraime, G. Freeman, S. Subbanna, M. Doherty, J. Dunn, C. Dickey, D. Greenberg, R. Groves, M. Meghelli, A. Rylyakov, M. Sorna, O. Schreiber, D. Herman, and T. Tanji, "0.13  $\mu\text{m}$  210 GHz  $f_T$  SiGe HBTs—expanding the horizons of

- SiGe BiCMOS", International Solid-State Circuits Conference, ISSCC, Digest of Technical papers, pp. 180–181 (2002).
7. Y. Yu, R. Lewen, S. Irmscher, U. Westergren, L. Thylen, U. Eriksson, and W.S. Lee, "80 Gb/s ETDM Transmitter with a Traveling-Wave Electroabsorption Modulator", in Proc. Optical Fiber Communication Conference, OFC 2005, Paper OWE1 (2005).
  8. H.-G. Bach, A. Beling, G.G. Mekonnen, R. Kunkel, D. Schmidt, W. Ebert, A. Seeger, M. Stollberg, and W. Schlaak, "InP-Based Waveguide-Integrated Photodetector with 100 GHz Bandwidth", IEEE J. Select. Topics on Quantum Electron. **10** (4), 668–672 (2004).
  9. K. Schuh, B. Junginger, E. Lach, A. Klekamp, E. Schlag, "85.4 Gbit/s ETDM receiver with full rate electronic clock recovery", in Proc. European Conference on Optical Communication, ECOC 2004, PDP Th4.1.1 (2004).
  10. O. Kamatani and S. Kawanishi, "Add/drop operation for 100 Gbit/s optical signal based on optical wavelength conversion by four-wave mixing", Electron. Lett. **32**, 911–913 (1996).
  11. C. Schubert, C. Schmidt, S. Ferber, R. Ludwig, and H.G. Weber, "Error-free all-optical add-drop multiplexing at 160 Gbit/s", Electron. Lett. **39**, 1074–1076 (2003).
  12. J.P. Turkiewicz, E. Tangdionga, G. Lehmann, H. Rohde, W. Schairer, Y.R. Zhou, E.S.R. Sikora, A. Lord, D.B. Payne, G.-D. Khoe, and H. de Waardt, "160 Gbit/s OTDM networking using deployed fiber", J. Lightwave Technol. **23**, 225–235 (2005).
  13. H.F. Chou, J.E. Bowers, and D.J. Blumenthal, "Compact 160-Gb/s Add-Drop Multiplexing with a 40-Gb/s Base-Rate", Optical Fiber Communication Conf., 2004, PDP28 (2004).
  14. S. Nakamura, Y. Ueno, and K. Tajima, "168-Gb/s all-optical wavelength conversion with a symmetric-Mach-Zehnder-type switch", Photon. Technol. Lett. **13**, 1091–1093 (2001).
  15. J. Leuthold, C. Joyner, B. Mikkelsen, G. Raybon, J. Pleumeekers, B. Miller, K. Dreyer, and C. Burrus, "100 Gbit/s all-optical wavelength conversion with integrated SOA delayed-interference configuration", Electron. Lett. **36**, 1129–1130 (2000).
  16. J. Hansryd, P.A. Andrekson, M. Westlund, J. Li, and P.-O. Hedekvist, "Fiber-based optical parametric amplifiers and their applications", IEEE J. Select. Topics Quantum Electron. **8**, 506–520 (2002).
  17. F. Futami, R. Okabe, Y. Takita, and S. Watanabe, "Transparent wavelength conversion at up to 160 Gb/s by using supercontinuum generation in a nonlinear fiber", Proc. Optical Amplifiers and Applications, OAA 2003 at Otaru, Japan, Paper MD07 (2003).
  18. S. Ferber, R. Ludwig, F. Futami, S. Watanabe, C. Boerner, C. Schmidt-Langhorst, L. Molle, K. Habel, M. Rohde, and H.G. Weber, "160 Gbit/s regenerating conversion node", in Proc. Optical Fiber Communication Conference, OFC 2004, Los Angeles, CA, USA, paper ThT2 (2004).
  19. S. Watanabe, R. Ludwig, F. Futami, C. Schubert, S. Ferber, C. Boerner, C. Schmidt-Langhorst, J. Berger, and H.G. Weber, "Ultrafast all-optical 3R-regeneration", IEICE Trans. Electron. **E87-C** (7), 1114–1118 (2004).
  20. P.V. Mamyshev, "All-optical data regeneration based on self-phase modulation effect", in Proc. European Conference on Optical Communications, ECOC 1998, Madrid, Spain, Volume 1, pp. 475–476 (1998).
  21. T. Ohara, H. Takara, I. Shake, K. Mori, S. Kawanishi, S. Mino, T. Yamada, M. Ishii, T. Kitoh, T. Kitagawa, K.R. Parameswaran, and M.M. Fejer, "160 Gbit/s optical-time-division multiplexing with PPLN hybrid integrated planar lightwave circuit", IEEE Photon. Technol. Lett. **15**, 302–304 (2003).

22. T. Ohara, H. Takara, I. Shake, K. Mori, K. Sato, S. Kawanishi, S. Mino, T. Yamada, M. Ishii, I. Ogawa, T. Kitoh, K. Magari, M. Okamoto, R.V. Roussev, J.R. Kurz, K.R. Parameswaran, and M.M. Fejer, "160-Gb/s OTDM transmission using integrated all-optical MUX/DEMUX with all-channel modulation and demultiplexing", *IEEE Photon. Technol. Lett.* **16**, 650–652 (2004).
23. H. Murai, K. Masatoshi, H. Tsuji, and K. Fujii, "Single Channel 160 Gbit/s Carrier-Suppressed RZ Transmission over 640 km with EA Modulator based OTDM Module", *ECOC 2003*, paper Mo.3.6.4, Rimini.
24. K.J. Blow, N.J. Doran, and B.P. Nelson, "Demonstration of the nonlinear fibre loop mirror as an ultrafast all-optical demultiplexer", *Electron. Lett.* **26**, 962–963 (1990).
25. A. Bjarklev, J. Broeng, and A.S. Bjarklev, *Photonic Crystal Fibers* (Kluwer Academic Publishers, Dordrecht, The Netherlands, 2003).
26. A. Suzuki, X. Wang, Y. Ogawa, and S. Nakamura, "10 × 320 Gbit/s (3.2 Tbit/s) DWDM/OTDM transmission by semiconductor based devices", *Proc. ECOC 2004*, paper Th4.1.7.
27. K. Tajima, S. Nakamura, and A. Furukawa, "Hybrid-integrated symmetric Mach-Zehnder all-optical switches and ultrafast signal processing" *IEICE Trans. Electron.* **E87-C** (7), 1119–1125 (2004).
28. S. Diez, R. Ludwig, and H.G. Weber, "All-optical switch for TDM and WDM/TDM systems demonstrated in a 640 Gbit/s demultiplexing experiment", *Electron. Lett.* **34**, 803 (1998).
29. S. Kodama, T. Yoshimatsu, and H. Ito, "320 Gbit/s error-free demultiplexing using ultrafast optical gate monolithically integrating a photodiode and electroabsorption modulator", *Electron. Lett.* **39** (17), 1269–1270 (2003).
30. S. Kodama, T. Yoshimatsu, and H. Ito, "500-Gbit/s demultiplexing operation of monolithic PD-EAM gate", postdeadline paper Th4.2.8, *ECOC 2003*, Rimini.
31. I. Shake, H. Takara, K. Uchiyama, I. Ogawa, T. Kitoh, T. Kitagawa, M. Okamoto, K. Magari, Y. Suzuki, and T. Morioka, "160 Gbit/s full optical time-division demultiplexing using FWM of SOA-array integrated on PLC", *Electron Lett.* **38**, 37–38 (2002).
32. O. Kamatani and S. Kawanishi, "Prescaled Timing extraction from 400 Gbit/s optical signal using a phase lock loop based on four-wave mixing", *IEEE Photon. Technol. Lett.* **8**, 1094–1096 (1996).
33. C. Boerner, V. Marembert, S. Ferber, C. Schubert, C. Schmidt-Langhorst, R. Ludwig, and H.G. Weber, "320 Gbit/s clock recovery with electro-optical PLL using a bidirectionally operated electroabsorption modulator as phase comparator" in *Proc. Optical Fiber Communication Conference, OFC 2005*, paper OTuO3 (2005).
34. B. J. Eggleton, B. Mikkelsen, G. Raybon, A. Ahuja, J.A. Rogers, P.S. Westbrook, T.N. Nielsen, S. Stulz, and K. Dreyer, "Tunable dispersion compensation in a 160 Gb/s TDM system by voltage controlled chirped fiber Bragg grating" *IEEE Photon. Technol. Lett.* **12**, 1022–1024 (2000).
35. C.K. Madsen, "Integrated waveguide allpass filter tunable dispersion compensator", *OFC' 2002*, TuT1.
36. T. Inui, T. Komukai, M. Nakazawa, K. Suzuki, K.R. Tamura, K. Uchiyama, and T. Morioka, "Adaptive dispersion slope equalizer using a nonlinearly chirped fiber Bragg grating pair with a novel dispersion detection technique", *IEEE Photon. Technol. Lett.* **14**, 549–551 (2002).
37. S. Wakabayashi, A. Baba, H. Moriya, X. Wang, T. Hasegawa, and A. Suzuki, "Tunable dispersion and dispersion slope compensator based on two twin chirped FBGs with temperature gradient for 160 Gbit/s transmission." *IEICE Trans. Electron.* **E87-C**, 1100–1105 (2004).



38. B. Mikkelsen, G. Raybon, R.-J. Essiambre, A.J. Stentz, T.N. Nielsen, D.W. Peckham, L. Hsu, L. Gruner-Nielsen, K. Dreyer, and J.E. Johnson, "320 Gbit/s single-channel pseudolinear transmission over 200 km nonzero-dispersion fiber", *IEEE Photon. Technol. Lett.* **12**, 1400–1402 (2000).
39. A.H. Gnauck, G. Raybon, P.G. Bernasconi, J. Leuthold, C.R. Doerr, and L.W. Stulz, "1 Tb/s  $6 \times 170.6$  Gb/s transmission over 2000 km NZDF using OTDM and RZ-DPSK", *IEEE Photon. Technol. Lett.* **15** (11), 1618–1620 (2003).
40. S. Weisser, S. Ferber, L. Raddatz, R. Ludwig, A. Benz, C. Boerner, H.G. Weber, "Single- and Alternating Polarization 170 Gbit/s Transmission up to 4000 km using Dispersion-Managed Fiber and All-Raman Amplification", *IEEE Photon. Technol. Lett.* **18** (12), 1320–1322 (2006).
41. M. Westlund, H. Sunnerud, J. Li, J. Hansryd, M. Karlsson, P.O. Hedekvist, and P.A. Andrekson, "Long-term automatic PMD compensation for 160 Gbit/s RZ transmission", *Electron. Lett.* **38**, 982–983 (2002).
42. T. Miyazaki, M. Daikoku, I. Morita, T. Otani, Y. Nagao, M. Suzuki, and F. Kubota, "Stable 160 Gbit/s DPSK transmission using a simple PMD compensator on the field photonic network test bed of JGN II", *Proc. OECC 2004*, PD-1-3.
43. F. Buchali, W. Baumert, M. Schmidt, and H. Buelow, "Dynamic distortion compensation in a 160 Gb/s RZ OTDM system: adaptive 2 stage PMD compensation", *Optical Fiber Communication Conf.*, pp. 589–590 (2003).
44. S. Kieckbusch, S. Ferber, H. Rosenfeldt, R. Ludwig, A. Ehrhardt, E. Brinkmeyer, and H.G. Weber, "Automatic PMD compensator in a single-channel 160 Gb/s transmission over deployed fiber using RZ-DPSK modulation format" *J. Lightwave Technol.* **23** (1), 165–171 (2005).
45. M. Schmidt, M. Witte, F. Buchali, E. Lach, E. Le Rouzic, S. Salaun, S. Vorbeck, and R. Leppla, "8  $\times$  170 Gbit/s DWDM Field Transmission Experiment over 430 km SSMF Using Adaptive PMD Compensation", *ECOC 2004 Stockholm*, PDP Th4.1.2.
46. M. Nakazawa, K. Suzuki, E. Yoshida, E. Yamada, T. Kitoh, and M. Kawachi, "160 Gbit/s soliton data transmission over 200 km", *Electron. Lett.* **31**, 565–566 (1995).
47. S. Kawanishi, H. Takara, T. Morioka, O. Kamatani, and M. Saruwatari, "200 Gbit/s, 100 km time-division-multiplexed optical transmission using supercontinuum pulses with prescaled PLL timing extraction and all-optical demultiplexing", *Electron. Lett.* **31**, 816–817 (1995).
48. S. Kawanishi, H. Takara, T. Morioka, O. Kamatani, K. Takiguchi, T. Kitoh, and M. Saruwatari, "Single channel 400 Gbit/s time-division-multiplexed transmission of 0.98 ps pulses over 40 km employing dispersion slope compensation", *Electron. Lett.* **32**, 916 (1996).
49. M. Nakazawa, E. Yoshida, T. Yamamoto, E. Yamada, and A. Sahara, "TDM single channel 640 Gbit/s transmission experiment over 60 km using 400 fs pulse train and walk-off free, dispersion flattened nonlinear optical loop mirror", *Electron. Lett.* **34**, 907–908 (1998).
50. T. Yamamoto, E. Yoshida, K.R. Tamura, K. Yonenaga, and M. Nakazawa, "640 Gbit/s optical TDM transmission over 92 km through a dispersion managed fiber consisting of single-mode fiber and reverse dispersion fibre", *IEEE Photon. Technol. Lett.* **12**, 353–355 (2000).
51. M. Nakazawa, T. Yamamoto, and K. R. Tamura, "1.28 Tbit/s–70 km OTDM transmission using third-and fourth-order simultaneous dispersion compensation with a phase modulator", *Electron. Lett.* **36**, 2027–2029 (2000).
52. S. Kawanishi, H. Takara, K. Uchiyama, I. Shake, O. Kamatani, and H. Takahashi, "1.4 Tbit/s (200 Gbit/s  $\times$  7 ch) 50 km optical transmission experiment", *Electron. Lett.* **33**, 1716–1717 (1997).

53. S. Kawanishi, H. Takara, K. Uchiyama, I. Shake, and K. Mori, "3 Tbit/s (160 Gbit/s  $\times$  19 channel) optical TDM and WDM transmission experiment", *Electron. Lett.* **35** (10), 826–827 (1999).
54. R. Ludwig, U. Feiste, S. Diez, C. Schubert, C. Schmidt, H.J. Ehrke, and H.G. Weber, "Unrepeated 160 Gbit/s RZ single-channel transmission over 160 km of standard fibre at 1.55  $\mu$ m with hybrid MZI optical DEMUX", *Electron. Lett.* **36**, 1405–1406 (2000).
55. U. Feiste, R. Ludwig, C. Schubert, J. Berger, C. Schmidt, H.G. Weber, B. Schmauss, A. Munk, B. Buchold, D. Briggmann, F. Kueppers, and F. Rumpf, "160 Gbit/s transmission over 116 km field-installed fibre using 160 Gbit/s OTDM and 40 Gbit/s ETDM", *Electron. Lett.* **37**, 443–445 (2001).
56. T. Yamamoto, U. Feiste, J. Berger, C. Schubert, C. Schmidt, R. Ludwig, and H.G. Weber, "160Gbit/s demultiplexer with clock recovery using SOA-based interferometric switches and its application to 120 km fiber transmission", *ECOC'01, Amsterdam, Tu.L.2.6*.
57. A. Suzuki, X. Wang, T. Hasegawa, Y. Ogawa, S. Arahira, K. Tajima, and S. Nakamura, "8  $\times$  160Gb/s (1.28Tb/s) DWDM/OTDM unrepeated transmission over 140 km standard fiber by semiconductor-based devices", *ECOC 2003, Rimini, paper Mo3.6.1*.
58. J.P. Turkiewicz, E. Tangdionga, G.-D. Khoe, H. de Waardt, W. Schairer, H. Rohde, G. Lehmann, E.S.R. Sikora, Y.R. Zhou, A. Lord, and D.B. Payne, "Field trial of 160 Gbit/s OTDM add/drop node in a link of 275 km deployed fiber", in *Proc. Optical Fiber Commun. Conf. 2004, Los Angeles, CA, PDPI*.
59. D.D. Marcenac, A.D. Ellis, and D.G. Moodie, "80 Gbit/s OTDM using electroabsorption modulators", *Electron. Lett.* **34** (1), 101–103 (1998).
60. A.D. Ellis, J.K. Lucek, D. Pitcher, D.G. Moodie, and D. Cotter, "Full 10  $\times$  10 Gbit/s OTDM data generation and demultiplexing using electroabsorption modulators", *Electron. Lett.* **34** (18), 1766–1767 (1998).
61. B. Mikkelsen, G. Raybon, R.-J. Essiambre, K. Dreyer, Y. Su, L.E. Nelson, J.E. Johnson, G. Shtengel, A. Bond, D.G. Moodie, and A.D. Ellis, "160 Gbit/s single-channel transmission over 300 km nonzero-dispersion fiber with semiconductor based transmitter and demultiplexer", *ECOC 1999, postdeadline paper 2-3, Nice (1999)*.
62. J. Yu, K. Kojima, N. Chand, M.C. Fischer, R. Espindola, and T.G.B. Mason, "160 Gb/s single-channel unrepeated transmission over 200 km of non-zero dispersion shifted fiber", *Proc. ECOC 2001 paper PD M.1.10 (2001)*.
63. J.-L. Augé, M. Cavallari, M. Jones, P. Kean, D. Watley, and A. Hadjifotiou, "Single channel 160 Gbit/s OTDM propagation over 480 km of standard fiber using a 40 GHz semiconductor mode-locked laser pulse source", *OFC 2002, paper TuA3, Anaheim (2002)*.
64. E. Lach, M. Schmidt, K. Schuh, B. Junginger, G. Veith, and P. Nouchi, "Advanced 160 Gb/s OTDM system based on wavelength transparent 4  $\times$  40 Gb/s ETDM transmitters and receivers", *OFC 2002 Anaheim, paper TuA2*.
65. H. Murai, M. Kagawa, H. Tsuji, K. Fujii, Y. Hashimoto, and H. Yokoyama, "Single Channel 160 Gbit/s (40 Gbit/s  $\times$  4) 300 km Transmission Using EA Modulator based OTDM Module and 40 GHz External Cavity Mode-locked LD", *ECOC 2002, paper 2.1.4, Copenhagen*.
66. M. Schmidt, E. Lach, K. Schuh, M. Schilling, P. Sillard, and G. Veith, "Unrepeated 320 Gbit/s (8  $\times$  40 Gbit/s) OTDM transmission over 80 km TeraLight<sup>TM</sup>-reverse TeraLight<sup>TM</sup> fiber link", *ECOC 2003, We.4.P.117, Rimini*.
67. B. Mikkelsen, G. Raybon, B. Zhu, R.-J. Essiambre, P.G. Bernasconi, K. Dreyer, L.W. Stulz, and S.N. Knudsen, "High spectral efficiency (0.53 bit/s/Hz) WDM transmission of 160 Gb/s per wavelength over 400 km of fiber", *OFC 2001, paper ThF2-1, Anaheim*.

68. K. Schuh, M. Schmidt, E. Lach, B. Junginger, A. Klekamp, G. Veith, and P. Sillard, "4×160 Gbit/s DWDM / OTDM transmission over 3×80 km TeraLight™-Reverse TeraLight™-fibre", ECOC 2002, paper 2.1.2, Copenhagen (2002).
69. M. Schmidt, K. Schuh, E. Lach, M. Schilling, and G. Veith, "8×160 Gbit/s (1.28 Tbit/s DWDM transmission with 0.53 bit/s/Hz spectral efficiency using single EA-modulator based RZ pulse source and demux", ECOC 2003, paper Mo3.6.5, Rimini.
70. E. Lach, K. Schuh, M. Schmidt, B. Junginger, G. Charlet, P. Pecci, and G. Veith, "7×170 Gbit/s (160 Gbit/s + FEC overhead) DWDM transmission with 0.53 bit/s/Hz spectral efficiency over long haul distance of Standard SMF", Proc. ECOC 2003 paper PD Th4.3.5.
71. M. Daikoku, T. Otani, and M. Suzuki, "160 Gb/s Four WDM Quasi-linear transmission over 225 km NZ-DSF with 75 km spacing", IEEE Photon. Technol. Lett. **15** (8), 1165–1167 (2003).
72. S. Randel, B. Konrad, A. Hodzic, and K. Petermann, "Influence of bitwise phase changes on the performance of 160 Gbit/s transmission systems", ECOC 2002 Copenhagen Proc., Vol.3, paper P3.31 (2002).
73. M. Kagawa, H. Murai, H. Tsuji, and K. Fujii, "Performance comparison of bitwise phase-controlled 160 Gbit/s signal transmission using an OTDM multiplexer with phase-correlation monitor", in Proc. ECOC 2004, paper We 4.P.109 (2004).
74. Y. Su, L. Moller, C. Xie, R. Ryf, X. Liu, X. Wei, and S. Cabot, "Ultra high-speed data signals with alternating and pairwise alternating optical phases", J. Lightwave Technol. **23** (1), 26–31 (2005).
75. A. Beling, H.-G. Bach, D. Schmidt, G.G. Mekonnen, R. Ludwig, S. Ferber, C. Schubert, C. Boerner, B. Schmauss, J. Berger, C. Schmidt, U. Troppenz, and H.G. Weber, "Monolithically integrated balanced photodetector and its application in OTDM 160 Gbit/s DPSK transmission", Electron. Lett. **39**, 1204–1205 (2003).
76. S. Ferber, R. Ludwig, C. Boerner, A. Wietfeld, B. Schmauss, J. Berger, C. Schubert, G. Unterboersch, and H.G. Weber, "Comparison of DPSK and OOK modulation format in 160 Gbit/s transmission system", Electron. Lett. **39** (20), 1458–1459 (2003).
77. T. Miyazaki, M. Daikoku, I. Morita, T. Otani, Y. Nagao, M. Suzuki, and F. Kubota, "Stable 160 Gbit/s DPSK transmission using a simple PMD compensator on the field photonic network test bed of JGN II", Proc. OECC 2004, PD-1-3.
78. S. Ferber, R. Ludwig, C. Boerner, C. Schubert, C. Schmidt-Langhorst, M. Kroh, V. Marembert, and H.G. Weber, "160 Gbit/s DPSK transmission over 320 km fibre link with high long-term stability", Electron. Lett. **41**, 200–202 (2005).
79. F. Ferber, C. Schmidt-Langhorst, R. Ludwig, C. Boerner, C. Schubert, V. Marembert, M. Kroh, and H.G. Weber, "160 Gbit/s OTDM long-haul transmission with long-term stability using RZ-DPSK modulation format" IEICE Trans. Commun. **E88-B** (5), 1947–1954 (2005).
80. V. Marembert, C. Schubert, S. Ferber, K. Schulze, C. Schmidt-Langhorst, C. Boerner, M. Kroh, R. Ludwig, S. Watanabe, F. Futami, R. Okabe, and H.G. Weber, "Single-channel 640 Gbit/s DPSK Transmission over a 160 km Fibre Link", Proc. Europ. Conf. on Opt. Comm. (ECOC'04), Stockholm, Sweden, 2004. Post-deadline paper Th4.4.2.
81. A.H. Gnauck and P.J. Winzer, "Optical phase-shift-keyed transmission", J. Lightwave Technol. **23** (1), 115–130 (2005).
82. A. Fauzi Abas Ismail, D. Sandel, A. Hidayat, B. Milivojevic, S. Bhandare, H. Zhang, and R. Noe, "2.56 Tbit/s, 1.6 bit/s/Hz, 40 Gbaud RZ-DQPSK polarization division multiplex transmission over 273 km of fiber", OptoElectronic and Communication Conference, OECC 2004, Yokohama, Japan, PD-paper PD1-4 (2004).

83. B. Milivojevic, A.F. Abas, A. Hidayat, S. Bhandare, D. Sandel, R. Noé, M. Guy, and M. La-pointe, "1.6-bit/s/Hz, 160-Gbit/s, 230-km RZ-DQPSK Polarization Multiplex Transmission with Tunable Dispersion Compensation", *IEEE Photon. Technol. Lett.* **17** (2), 495 (2005).
84. S. Ferber, C. Schubert, R. Ludwig, C. Boerner, C. Schmidt-Langhorst, and H.G. Weber, "640 Gbit/s DQPSK Single-channel Transmission over 480 km Fibre Link", *Electron. Lett.* **41**, (22), 1234–1235 (2005).
85. H.G. Weber, S. Ferber, M. Kroh, C. Schmidt-Langhorst, R. Ludwig, V. Marembert, C. Boerner, F. Futami, S. Watanabe, C. Schubert, "Single Channel 1.28 Tbit/s and 2.56 Tbit/s DQPSK Transmission", *Electron. Lett.* **42**, 178–179 (2006).