



# Design Guidelines for Precast Structures with Cladding Panels in Seismic Zones

A. Colombo<sup>1</sup> and G. Toniolo<sup>2</sup>(✉)

<sup>1</sup> Assobeton, Italian Association of Precast Industry, Milan, Italy

<sup>2</sup> Department of Civil and Environmental Engineering,  
Politecnico di Milano, Milan, Italy  
giandomenico.t@gmail.com

**Abstract.** The paper presents a summary of the results of the experimental and analytical research on Improved fastening systems of cladding wall panels of precast buildings in seismic zones, performed within the scope of the European Project Safeclassing (EU Programme FP7-SME-2012-2 – Grant Agreement n. 314122), as codified in the pertinent documents issued by the research Consortium in terms of Design Guidelines for practical applications. Further than the investigation on the current fastening systems and the related acceptability analysis for existing structures, the paper deals with the specific design criteria for the isostatic, integrated and dissipative fastening systems that should be the basis for the new precast constructions in seismic zones.

## 1 Introduction

The experience of recent earthquakes, like L'Aquila 2009, Lorca 2011 and Emilia 2012 (see Fig. 1), showed the inadequacy of the present design criteria of the fastenings of the cladding wall panels. In addition to this one, another widespread serious deficiency has been noticed in buildings not designed for seismic action: the loss of bearing of beams and floor elements in dry simple supports that entrust the transmission of horizontal forces only to friction without mechanical restrainers (see Fig. 2). Proper connection devices are needed able to transfer horizontal forces also in absence of the gravity action. And this is valid also with reference to the possible lateral overturning of beams. These connection devices should be dimensioned taking into account the stiffening effects of the cladding panels with respect to the response of the bare frame structure.

For what concerns the former deficiency, the basic principle shall be that the fall of cladding wall panels under earthquake action shall be prevented following the same requirement of no collapse stated for the main structure by Eurocode 8. To this end the fastening devices and the whole connections of wall panels shall be verified for the effects of the seismic action in terms of forces and/or displacements as calculated through the proper structural analysis.

Following this principle, the structural analysis of precast buildings under seismic action shall properly take into account the role of cladding panels in the seismic response of the overall construction assembly. The models used in the analysis shall represent as close as possible the real arrangement of the construction, including panels



**Fig. 1.** Emilia 2012 – panel collapse



**Fig. 2.** Emilia 2012 – beam fall

and relative connections. Specific indications are given in the following clauses with reference to the systems of cladding connections discussed below.

The precast structures considered are frame systems made of columns and beams connected with horizontal floor diaphragms. In particular the roofs can provide rigid, deformable or null diaphragm action. To this frame system, for the peripheral cladding, a set of wall panels is added that, depending on the type of connections to the structure, may not interfere with the frame behaviour or may interfere leading to the interaction between the panels and the frame and to an increased stiffness of the system. In this dual wall-frame system a set of dissipative connections may be present able to attenuate the seismic response. All these structural systems have to be possibly analysed with proper specific calculation models.

## 2 General

As primary type of analysis for the current design practice the linear elastic analysis with response spectrum is proposed as regulated by Clause 4.3.3 of Eurocode 8, where the effects of energy dissipation at the ultimate limit state are represented by the behaviour factor  $q_p$  (see 5.11.1.4 of Eurocode 8). In particular from the analysis the forces and displacements on the connections of the panels are expected for the necessary pertinent verifications.

For new constructions the following suggestions refer to the modern production of precast concrete structural elements through processes under quality control as regulated by the present European harmonised standards.

With reference to the provisions of Chap. 5 of Eurocode 8, these structures, when provided with isostatic systems of wall panel connections, can have all the characteristics to be considered in ductility class high “DCH” (ductile reinforcement, proper detailing, overproportioned connections). However the use for frame structures of the high  $q_o$  factor given by Table 5.1 of Eurocode 8 to this class could lead to an excessive deformability incompatible with the requirements of the damage limitation state, with floor drifts larger than 1%. To fulfil this limit state a larger proportioning in size of the columns could be necessary (corresponding to a lower  $q_o$  factor), aware that in this way the frame structure will result over-dimensioned in strength. In any case it is highly recommended to apply the rules of DCH for reinforcement ductility, member detailing and connection over-proportioning (with  $k_p = 1,0$ ). In particular, for a full exploitation of the ductility resources in compression of the longitudinal bars of columns, in the critical regions of the columns a spacing of stirrups  $s \leq 3,5\phi$  should be adopted, with  $\phi$  diameter of the longitudinal bars.

If an integrated system of wall panel connections is adopted, the resulting dual wall-frame structure could be classified in ductility class medium “DCM” with a lower behaviour factor.

For all connection systems, a ratio  $\alpha_u/\alpha_1 = 1,0$  shall be taken, due to the null or low level of structural redundancy.

## 3 Existing Buildings

A structural analysis may be required for the verification of the seismic capacities of existing buildings, in terms of resistance and stability under the expected seismic action. Following the results of this verification, proper interventions of upgrading or retrofitting could be decided. These interventions should be performed according to the provisions of Eurocode 8 Part 3 and relevant National Annex. When it is technically and economically possible, a retrofitting should be made with the full fulfilment of the code requirements for new constructions. Otherwise the upgrading may correspond to an improvement of the capacity that doesn't reach the level required in the zone for the new constructions. In such a case lower return periods of the earthquake can be used leading to lower peak ground accelerations compared to those used for the new buildings in the zone. At present some countries allow the reduction factors as low as 0,6. In all cases the damage limitation requirement can be disregarded.

In the case of existing buildings originally not designed for seismic action, the analysis should be based on the assumption of a low ductility class for which a behaviour factor  $q = 1,5$  shall be adopted. If the existing buildings were designed for seismic action, higher behaviour factors can be used, if justified by the calculations made and the structural details adopted at the time of construction.

While the elastic modal spectrum analysis is the first choice in the current design practice, more refined inelastic analysis might be required in some cases, due to the highly complex non-linear properties of the panel-to-structure interaction, in order to obtain more reliable and less onerous results.

For seismic loading, the deformation property of the current fastening devices, like the hammer-head straps of Fig. 3, has a double course. In the horizontal direction parallel to the plane of the panels, a low interaction between the panel and the bare frame may be expected until a certain deformation threshold is not overcome. Within this deformation limit, the panel connection system behaves essentially as isostatic and relatively simple structural models can be used, basically neglecting the structure-to-cladding interaction.

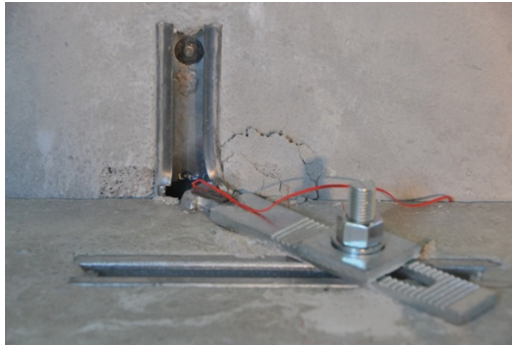
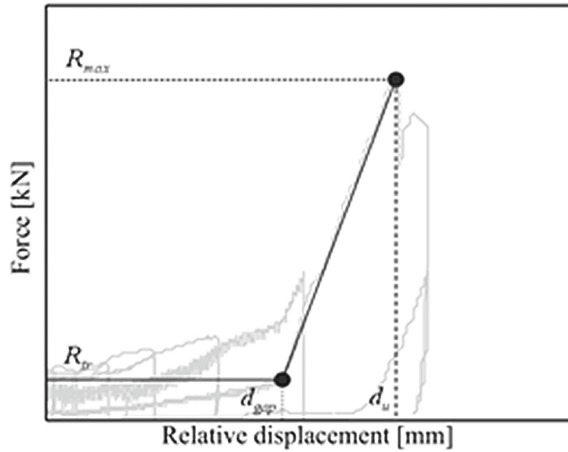

**Fig. 3.** Test on a hammer-head strap connection

When the quoted deformation limit is overcome, the free movement is stopped and more complex models should be used considering the interaction between the panels and the bare structure through the fastening devices. Figure 4 shows the elasto-plastic behaviour of the quoted hammer-head strap and a related possible model.

Anyway the consequent safety verifications will possibly demonstrate the inadequacy of the panel connection systems. In such a case proper upgrading or retrofitting interventions should be made. Any intervention of upgrading or retrofitting of panel connections on existing buildings should be made only when the adequacy of all the remaining parts of the structure has been verified to be compliant with the requirements of the chosen level of seismic resistance.

A little invasive technique of intervention on existing buildings to prevent the fall of wall panels under earthquake conditions consists of short slack cables connecting the panel to the main structural element as shown for vertical panels in Fig. 5.



**Fig. 4.** Cyclic behaviour of hammer-head strap

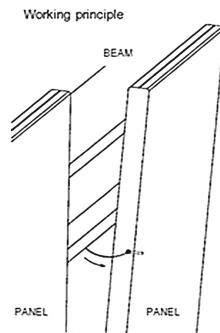

**Fig. 5.** Anti-fall restrainers

Considering that under earthquake conditions, after the possible failure of the original fastenings, the motion of panels is completely out of control, this solution can be used only for a quick upgrading of existing buildings in order to ensure their operativeness for a transitory period, waiting for a more reliable intervention.

Folded steel plates can be used, instead of the too rigid steel angles, in existing buildings to retrofit or upgrade the connections of horizontal panels to the structure (see Fig. 6). They ensure a good elastic and plastic deformability able to avoid the very high force response to the seismic action proper of the stiff wall systems. The installation of the steel folded plates doesn't require any special care for tolerances since they can be shaped in site on the existing situation and attached to column and panel with post-installed drilled fasteners.



**Fig. 6.** Folded plate angle

Folded steel plates can be effectively used also in new constructions. Figure 7 shows the use of folded steel plates for the connection of horizontal panels to the adjacent columns. Any panel is seated on a couple of steel brackets that ensure a vertical support independently from the other panels. Four folded steel plates are then fixed at the corners providing full translational restraints in all directions with a hyperstatic overall arrangement.

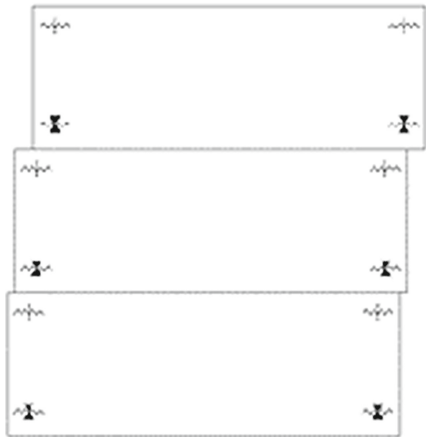

**Fig. 7.** Use of folded plates in horizontal panels

In the in-plane horizontal direction the folded plates have the elasto-plastic behaviour described in Fig. 8. In the vertical direction they can add a fixed bilateral restraint or leave a displacement freedom depending on the type of fastening on the column. The elastic deformability in the horizontal direction can attenuate the effects of thermal expansion.

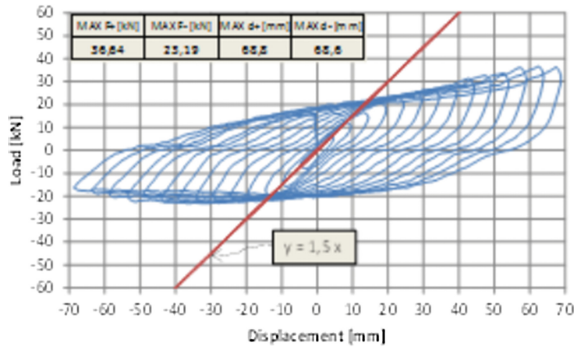

Fig. 8. Cyclic test on folded plate angle

## 4 Isostatic Connection System

In order to ensure the pure frame behaviour of the resisting structure, the connection system of the wall panels shall actually allow without reaction the large displacements of the frame structure under seismic action, except for possible minor unintended reaction effects due to friction or sealing. In this case one shall adopt sliding connection devices with adequate capacities (such as  $\pm 150$  mm or greater) or pinned connectors for free rotations.

It should be stated beforehand that at present the isostatic systems, adapted for seismic purposes as described below, are of easy application with a sufficient reliability.

Considering that the vertical panels are placed over the foundation beam, to which they transmit their weight, and are supported horizontally by the roof beam with connections placed close to the top, the arrangements to obtain an isostatic connection system for these panels are those shown in Fig. 9. The first solution adopts hinged lower and upper supports so to have a *pendulum behaviour* for any single panel (see Fig. 9a). The second solution adopts fixed supports at the base of the panels and two sliding connections to the structure at the upper position so to have a *cantilever behaviour* uncoupled from the structure (see Fig. 9b). The third solution adopts a simple seating of the panels on bearings placed at the two edges of the base side together with a hinged connection to the structure at the upper position so to have a *rocking behaviour* for large displacements (see Fig. 9c). For all the three solutions, in the out-of-plane direction the panels are supported with an isostatic pendulum scheme (see Fig. 9d).

In the pendulum arrangement (Fig. 9a), for a given top displacement  $d$  the adjacent vertical sides of the panels display a relative slide of  $bd/h$  where  $h$  is the height of the upper support and  $b$  is the width of the panels. In the meantime the two adjacent sides get closer by a minor quantity that requires in any case a free spacing between the panels (few millimetres) closed by the sealant. The sealing between the adjacent panels may give a minor reaction to the motion that can be neglected. The rotating base supports of the panels may display a friction reaction to the motion that has very small (negligible) dissipative effects on the seismic response. Since only vertical compression

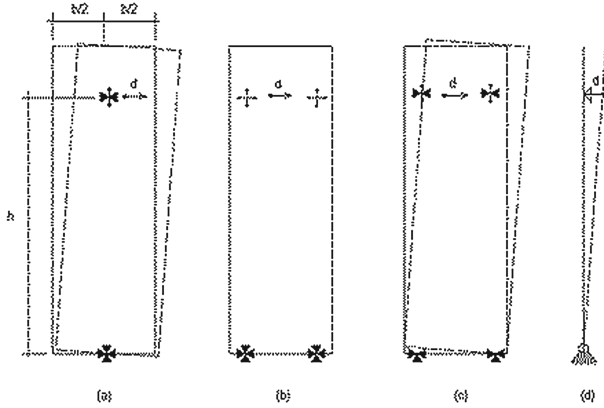

Fig. 9. Isostatic connection systems of vertical panels

forces are expected at the base supports, these can consist of simple seatings able to provide only an unilateral restraint in the vertical downwards direction. To allow for thermal expansion, the upper supports may be made of one or two lateral vertical slide channel bars able to transmit only horizontal forces.

The cantilever arrangement (Fig. 9b) keeps the panels still during the motion of the structure because of the horizontal slide channel bars placed at the upper position. To allow for thermal expansion vertical channel bars may be coupled to the horizontal ones (one in the beam and one in the panel). Sensible friction effects may arise due to the contemporary orthogonal forces caused by the biaxial vibratory motion. The base support of the panels can be provided with reinforcing bars protruding from the bottom and anchored by bond within corrugated sleeves inserted in the foundation and filled with no-shrinking mortar. Other types of dry mechanical connections may be adopted for the base support of the panels.

The rocking arrangement (Fig. 9) consists of the seating of the panels on the foundation through unilateral bearings that work only in compression. The two edges of the base side of the panel alternatively rise up during the rocking. Small horizontal actions applied to the upper connection of any single panel are equilibrated by its weight until they are  $\leq Gb/(2h)$ , where  $G$  is the weight of the panel,  $b$  is its width and  $h$  is the height of the applied horizontal action. In this condition the panels behave as integrated in the structure that becomes a dual wall-frame system with a much higher global stiffness. Under seismic action therefore the reacting system has an initial high horizontal stiffness that decreases when that limit is overcome and the panels begin to rock, behaving as isostatic. In the rotated position the panel, seated in its edge active bearing, provides a stabilizing constant horizontal force  $H = Gb/(2h)$ . At the reverse motion the panel seats back again on the two base lateral bearings restoring its initial stable equilibrium. The analysis of such vibration motion requires calculation codes with refined algorithms for the solution of the non linear equations.

The horizontal panels are connected externally to the adjacent columns to which they transmit their weight, being restrained horizontally by the same connections. The lowest panels can be seated directly with their weight on the foundation elements.



In this paper only the isostatic hanging (see Fig. 10a) and seated (see Fig. 10b) equivalent solutions are considered. The superimposed panels shall have a free spacing at the joint between the adjacent sides to allow the relative slide motion without friction. This joint is sealed with proper material (silicone) that may introduce a minor reaction effect. Any single panel is provided by two upper or lower vertical supports placed at the ends and fixed to the columns. One of them provides also the horizontal restraint in the plane of the panel. To allow for thermal expansion, the opposite one gives no horizontal reaction in the plane of the panel. At the opposite lower or upper side two couples of sliding connections are placed allowing the free horizontal and vertical displacements. All the four corner connections provide a fixed horizontal support orthogonal to the panel.

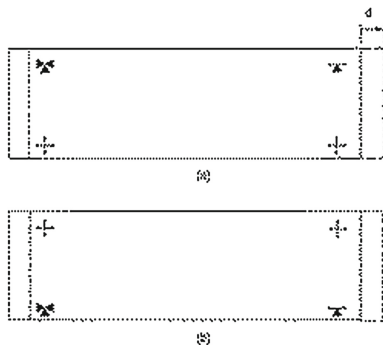

**Fig. 10.** Isostatic connection systems of horizontal panels

For buildings with isostatic arrangements of wall panel connections, the structural analysis under seismic action can refer to the frame system following the current design practice of such structures.

## 5 Integrated Connection Systems

In the integrated system the connections of each panel are arranged with a hyperstatic set of fixed supports. With this arrangement of connections the panels participate to the seismic response of the structure within a dual wall-frame system which has a much higher stiffness and a lower energy dissipation capacity compared to a pure frame and this leads to a structural seismic response with higher forces and lower displacements. The panel connections shall be proportioned by consequence, not with a local calculation based on the mass of the single panel, but from the analysis of the overall structural assembly with its global mass.

The adoption of an integrated system has also some side effects such as those of a strong engagement of the floor diaphragm action necessary to take the inertia forces of the floors to the lateral resisting walls. This can lead to very high joint forces.

A typical hyperstatic arrangement of connections is shown in Fig. 11 for vertical panels. Four fastenings are used, one for each corner, the lower two attached to the bottom foundation beam with fixed connections, the upper two attached to the top beam with vertically sliding connections that allow the free thermal expansion of the panel. With this arrangement any panel acts as a vertical cantilever beam clamped at its bottom and pinned at its top.

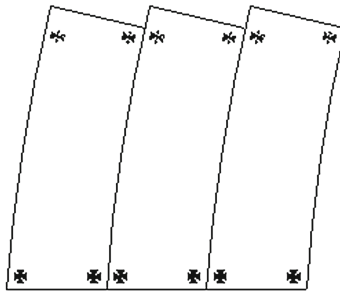

Fig. 11. Integrated connection system of vertical panels

Different types of base fixed connecting mechanisms can be adopted, like the connections with protruding bars, with bolted shoes and with bolted plates. Independently from the type of connection, a gap should be left during construction between the panel and the supporting beam, which is filled with high strength, non-shrinking grout after mounting the panels. The purpose of this bed of mortar is to form a uniform contact between the panel and the supporting beam, necessary to ensure friction and prevent sliding.

Due to the large in-plane stiffness of the panels in their integrated arrangement, significant internal forces can develop during strong earthquakes. Openings in the panels reduce their local strength and, therefore, appropriate resistance verifications should be performed.

Figure 12 shows a hyperstatic arrangement of connections for horizontal panels. Four fixed fastenings are used, one for each corner, attached to the contiguous columns. With this arrangement any panel acts as a horizontal beam clamped at its ends.

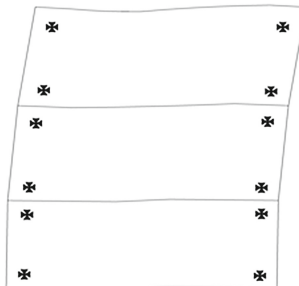

Fig. 12. Integrated connection system of horizontal panels

In case of horizontal panels, the fixed connections applied to the columns affect significantly their deformation during earthquakes, inducing the development of high local forces. Additionally, the insertion of adequate fastening devices in the reduced dimensions of the columns without endanger their resistance could be a difficult construction problem. For these reasons horizontal panel arrangement in integrated systems are not recommended.

## 6 Dissipative Connection Systems

Between the two extreme solutions of isostatic systems, with their large displacement demand, and integrated systems, with their high force demand, the dissipative systems of cladding connections offer an intermediate solution able to keep displacements and forces within lower predetermined limits.

In this section two structural arrangements are considered, one for vertical panels and one for horizontal panels. Actually in Sect. 3 a third arrangement has been presented, again for horizontal panels and the use of folded plates angles.

For vertical panels, starting from the isostatic pendulum arrangement of fastenings of Fig. 9a, a number of dissipative mutual connectors are added between the panels, opposing the relative slide at their vertical joints. Figure 13a shows this solution where the zig-zag lines indicate the position of the inter-panel dissipative devices. An equivalent solution, with an lower energy dissipation efficiency, can be obtained starting from the isostatic rocking system of Fig. 9c.

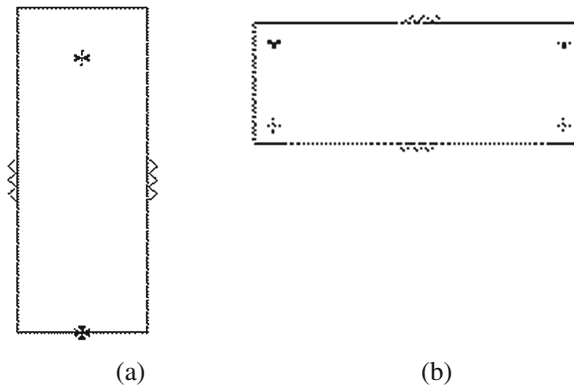

**Fig. 13.** Dissipative connection arrangements (a) for vertical, (b) for horizontal panels

For horizontal panels, starting from the isostatic hanging arrangement of fastenings of Fig. 10a, a number of dissipative mutual connectors are added between the panels, opposing the relative slide at their joints. An equivalent solution can be obtained starting from the isostatic seated arrangement of Fig. 10b.

The dissipative devices considered in this paper are the friction based connectors, the multi-slit plates and the steel cushions.

The friction devices are made of two steel T shape parts that are fixed with a symmetrical set of bolted fasteners to the adjacent panels in special recesses and coupled with two lateral bolted steel plates, as shown in Fig. 14. The length of the slotted holes made in the web of the T shape profiles gives the limit to the reciprocal slide between the parts. The tightening torque given to the bolts, controlled by dynamometric wrench, activates the friction between the plates determining the slip threshold shear force. Two brass sheets are interposed between the steel plates and the profiles to ensure the stability of the repeated slide cycles.

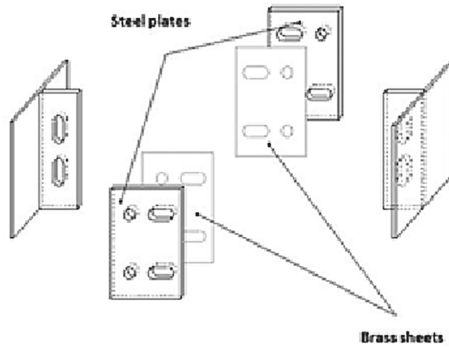

Fig. 14. Friction based dissipative devices

A centred longitudinal shear is transmitted through this device, limited to the threshold value. The cyclic dissipative behaviour is shown by the experimental diagram of Fig. 15; it can be represented with a good approximation by a rigid-pseudo plastic model. After a strong friction engagement the bolts shall be released for re-centring of the structure and re-tightened; the same steel plates and brass sheets can be re-used with the same potential behaviour.

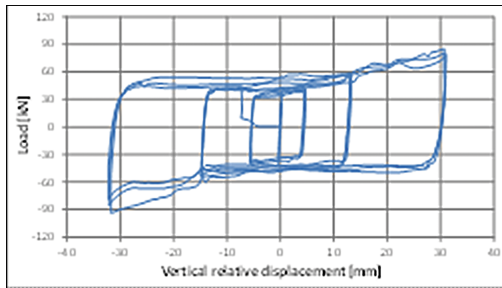
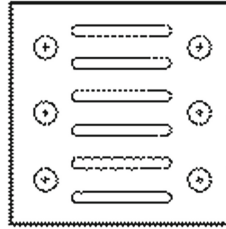

Fig. 15. Force-displacement cycles for friction devices

The multi-slit devices considered in this paper have a composition similar to the friction devices, where the two lateral solid steel plates used in the latter devices are replaced by as many lateral plates provided with slits of various shapes and sizes. The slits isolate a number of slender strips and in this way move the shear behaviour of the solid plates to a flexural diffused behaviour of the single strips which is suitable for energy dissipation (see Fig. 16).



**Fig. 16.** A type of multi-slit dissipative device

The cyclic dissipative behaviour is shown by the experimental diagram of Fig. 17; it can be represented with a good approximation by a bi-linear hardening model. After significant plastic deformations, the multi-slit devices shall be removed for re-centring the structure and replaced with new ones.

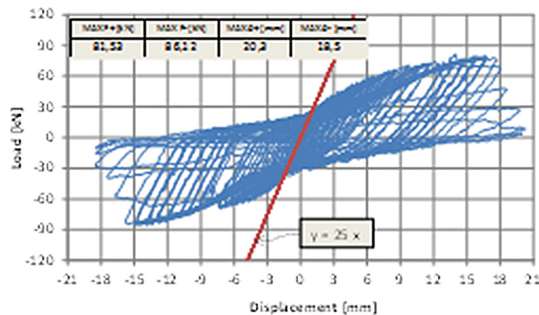

**Fig. 17.** Force-displacement cycles for multi-slit devices

The steel cushions considered in this document are made of a flattened ring-shape plate that is fixed with central fasteners to the adjacent panels in special recesses as shown in Fig. 18a. They can be utilized wherever multi-slit and friction devices are used. They can transmit longitudinal shear forces with the deformation mechanism described in Fig. 18b.

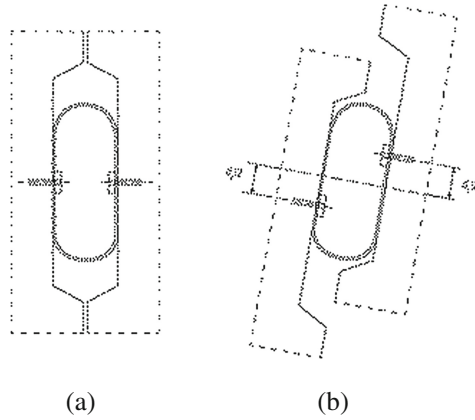

**Fig. 18.** Steel cushion and its deformation mechanism

The cyclic dissipative behaviour is shown by the experimental diagram of Fig. 19; it can be represented by an approximate bi-linear hardening model or by more accurate algebraic curves. After significant plastic deformations, the steel cushions shall be removed for re-centring the structure and replaced with new ones.

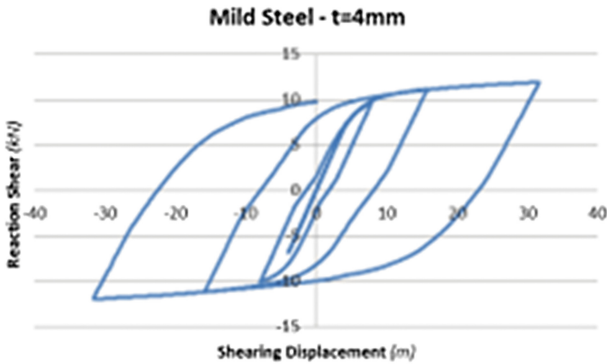

**Fig. 19.** Force-displacement cycles for steel cushions

With reference to vertical panels, in terms of roof drift  $d_x$  of an one-storey building, the relative slide play  $\pm s_z$  between two adjacent panels (see Fig. 20) leads to  $d_x = \pm s_z h/b$  that, for the common dimensions of the panels, corresponds to about three times its value.

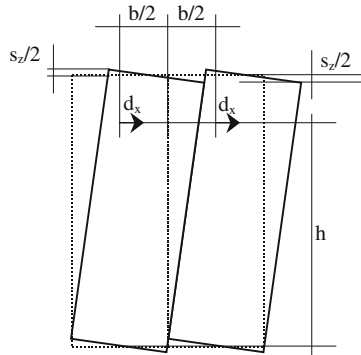

**Fig. 20.** Displacement mechanism of vertical panels

Figure 21 shows the forces transmitted between the panels and the frame structure, where (a) is the end panel that transmits a relevant vertical force to the foundation, (b) is an internal panel that exchanges vertical shear forces at both sides.

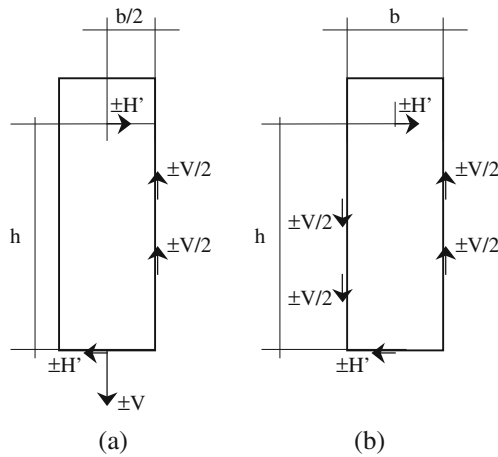

**Fig. 21.** Forces applied to (a) end panel, (b) internal panel

The horizontal resistance contributions can be deduced from the rotation equilibrium in terms of the shear  $V$  transmitted by the joint connections:

$$H' = V b / (2h) \quad H = V b / h$$

If  $V$  is the threshold force of the rigid-pseudo plastic model of a friction dissipative device, the sum  $F$  of these horizontal forces corresponds to the maximum response of the structure. Compared to the maximum response  $F_{max}$  of the integrated dual

wall-frame system, where the initial high stiffness is given by the large walls with fixed panel connections, this response leads to the required reduction (behaviour) factor

$$q = F_{\max} / F$$

The calculation of  $F_{\max}$  can be referred to the total vibrating mass of the building and to the maximum spectral response of the site. The equation above can be used to proportion the dissipative devices in number and strength assuming a proper (conservative) value of the  $q$  factor.

## 7 Conclusions

Recent earthquakes pointed out the often inadequate fastening systems of cladding panel to the main structure. For this residual weak point the last European research project Safecladding developed the proper design criteria, indicating the possible solutions of isostatic, integrated or dissipative connections. The first one is the simplest to be applied with the use of available products. The second solution draws very high seismic forces in the structural joints and need new improved connection devices. The third solution is at present out of the current construction experience, but it seems very promising for an effective application. The experience in the new constructions of these solutions will solve the questions still open for a generalised routine praxis.

**Acknowledgments.** In the present paper the authors summarized the outcome of the wide experimental and analytical research on Improved fastening systems of cladding wall panels of precast buildings in seismic zones, performed within the European Project Safecladding (EU Programme FP7-SME-2012-2 – Grant Agreement n. 314122). The work has been carried out by the research providers on the basis of the tasks committed to each of them. The results have been codified in the two detailed Design Guidelines for practical applications quoted in the References (Safecladding Project 2015a, b). The intellectual paternity belongs to the single research groups and to the consortium as a whole that assured an organic co-ordination of the different contributions.

With reference to the research of concern with its different activities, a mention shall be devoted to the research providers, with Dr. Paolo Negro and Mr. Marco Lamperti for ELSA Lab. of the JRC (Ispra), Prof. Matej Fischinger and Prof. Tatjana Isakovic for Ljubljana group, Prof. Ioannis Psycharis for Athens group, Prof. Fabio Biondini and Dr. Bruno Dal Lago for Milan group, Prof. Faruk Karadogan and Prof. Ercan Yuksel for Istanbul group, in addition to Mr. Claudio Pagani and Antonello Gasperi for the Company BS Italia and the authors of this paper themselves.

The national industrial associations were represented by Mr. Bulent Tokman (TPCA, Turkey), Mr. Alejandro Lopez (ANDECE, Spain), Mr. Thomas Sippel (VBBF, Germany), in addition to Assobeton (Italy) and the Turkish Company YAPI. The general manager of the research project was Mr. Alessio Rimoldi of the international association of the precast industry BIBM.



## References

- Safecladding Project (2015a) Design guidelines for precast structures with cladding panels, Deliverable 6.1
- Safecladding Project (2015b). Design guidelines for wall panel connections, Deliverable 6.2