

Joachim Wink  
Fatemeh Mohammadipanah  
Javad Hamedi *Editors*

# Biology and Biotechnology of Actinobacteria

 Springer

---

# Biology and Biotechnology of Actinobacteria

---

Joachim Wink  
Fatemeh Mohammadipanah  
Javad Hamedi  
Editors

# Biology and Biotechnology of Actinobacteria

 Springer

*Editors*

Joachim Wink  
Microbial Strain Collection;  
Helmholtz-Centre for Infection Research  
Braunschweig  
Germany

Fatemeh Mohammadipanah  
College of Science  
University of Tehran  
Tehran  
Iran

Javad Hamed  
College of Science  
University of Tehran  
Tehran  
Iran

ISBN 978-3-319-60338-4      ISBN 978-3-319-60339-1 (eBook)  
DOI 10.1007/978-3-319-60339-1

Library of Congress Control Number: 2017955832

© Springer International Publishing AG 2017

This work is subject to copyright. All rights are reserved by the Publisher, whether the whole or part of the material is concerned, specifically the rights of translation, reprinting, reuse of illustrations, recitation, broadcasting, reproduction on microfilms or in any other physical way, and transmission or information storage and retrieval, electronic adaptation, computer software, or by similar or dissimilar methodology now known or hereafter developed.

The use of general descriptive names, registered names, trademarks, service marks, etc. in this publication does not imply, even in the absence of a specific statement, that such names are exempt from the relevant protective laws and regulations and therefore free for general use.

The publisher, the authors and the editors are safe to assume that the advice and information in this book are believed to be true and accurate at the date of publication. Neither the publisher nor the authors or the editors give a warranty, express or implied, with respect to the material contained herein or for any errors or omissions that may have been made. The publisher remains neutral with regard to jurisdictional claims in published maps and institutional affiliations.

Printed on acid-free paper

This Springer imprint is published by Springer Nature  
The registered company is Springer International Publishing AG  
The registered company address is: Gewerbestrasse 11, 6330 Cham, Switzerland

---

## Preface

Actinobacteria are Gram positive organisms characterized by normally having a high mol% G+C ratio, filamentous or non-filamentous morphologies, and some members that produce spores through a differentiated developmental life cycle. The Class Actinobacteria comprises 6 classes, 6 orders, 14 suborders, and 56 families. The number of introduced genera of this taxon and their physiological diversity proposes that taxonomical identification of this group will be a dynamic process in future. Actinobacteria are autochthonous inhabitants of soil and marine and often among the dominant population of their ecosystems and may occur in extreme environments.

Members of the class Actinobacteria and the development of mankind are inseparably connected. The knowledge of this bacterial group goes back to the year 1839 when Corda identified *Actinomyces bovis* as the organism being responsible for bone swellings in bovine and to the year 1882 when Robert Koch identified *Mycobacterium tuberculosis* as the pathogen being responsible for tuberculosis. Since the 1940s, the history of antibiotic discovery and development is inseparably connected to Actinobacteria and especially to members of the genus *Streptomyces*. Streptomycin was the first antibiotic on market produced by an Actinobacterium and was developed in Waksman's laboratories. Today, we know that Actinobacteria exhibit large genomes (often more than 8 MB), which is one of the reasons for their potency to produce so many different bioactive metabolites. Actinobacteria of diverse genera like *Streptomyces*, *Saccharopolyspora*, *Amycolatopsis*, *Micromonospora*, and *Actinoplanes* are the producers of clinically used antibiotics and many other compounds that are used in pharmacy, agriculture, veterinary, animal husbandry, industry, and many other biotechnological fields.

Many of Actinobacteria are soil bacteria, but also pathogenic or saprophytic organisms belong to this group. Many of them show a characteristic differentiation by forming conidia that are usually regarded as spores. The conidia are arranged in spore chains, sporangia, or are found as single spores on sporophores. This high variation in their morphological form made taxonomy very difficult from the early beginning on. The cell differentiation we find in Actinobacteria is unique in microbiology and has been considered as model organisms to study the differentiation in Prokaryotes.

Actinobacteria are the most promising source of small bioactive molecules, and it is estimated that only 10% of actinobacterial bioactive chemicals have been

discovered to date. In this regard, the number and diversity of biosynthetic gene clusters in their genome justify their bioprospecting for new biological discovery. Actinobacterial sources estimate for about 45% of all microbial bioactive metabolites with 7,600 of these compounds (80%) being produced by the *Streptomyces* species. With more than 600 validly described species, *Streptomyces* is the largest genus in the bacterial world. Many of them have been isolated all over the world during industrial screening programs for many different purposes. However, rare Actinobacteria are also ubiquitous. Predominant and rare Actinobacteria surrounding us present in various ecosystems as free living, symbionts, or pathogens. They live in various soil, freshwater, seas and oceans, on surfaces of plants and animals, and into their cells or their cavities. Some actinobacteria can live in extreme environments, such as hot deserts, polar sites, acidic or alkaline soil and water or deep sea, and many other unusual habitats.

Despite the large number of studies on physiology, genetics, ecology, and applications of Actinobacteria, no up-to-date and comprehensive reference book covering all the mentioned aspects has been published until now. This book will see the emergence of insights about growth life cycle, cellular components, taxonomy, genetics, physiology, metabolism, and biotechnological applications to the name of fascinating aspects of Actinobacterial biology. We hope this book will contribute to a true understanding of all biological aspects of Actinobacteria.

Braunschweig, Germany  
Tehran, Iran  
Tehran, Iran

Joachim Wink  
Fatemeh Mohammadipanah  
Javad Hamedi

---

# Contents

<b>1 Introduction</b> .....	1
Javad Hamed and Joachim Wink	
<b>2 The Cellular Structure of Actinobacteria</b> .....	5
Javad Hamed and Naghmeh Poorinmohammad	
<b>3 Growth and Life Cycle of Actinobacteria</b> .....	29
Javad Hamed, Naghmeh Poorinmohammad, and Reyhaneh Papiran	
<b>4 Classification and Taxonomy of Actinobacteria</b> .....	51
Fatemeh Mohammadipanah and Mona Dehhaghi	
<b>5 The Genetic System of Actinobacteria</b> .....	79
Horbal Lilya and Luzhetskyy Andriy	
<b>6 Ecology and Habitat Distribution of Actinobacteria</b> .....	123
D.İ. Kurtböke	
<b>7 Physiology of Actinobacteria</b> .....	151
Olga Genilloud	
<b>8 Regulation of Secondary Metabolites of Actinobacteria</b> .....	181
Wolfgang Wohlleben, Agnieszka Bera, Yvonne Mast, and Evi Stegmann	
<b>9 Symbiosis and Pathogenicity of Actinobacteria</b> .....	233
Yitayal S. Anteneh and Christopher M.M. Franco	
<b>10 The Role of Actinobacteria in Biotechnology</b> .....	269
Javad Hamed, Naghmeh Poorinmohammad, and Joachim Wink	
<b>11 Practical Aspects of Working with Actinobacteria</b> .....	329
Joachim Wink, Fatemeh Mohammadipanah, and Hamed Kazemi Shariat Panahi	
<b>12 Post-genomic Studies and Systems Biology of Actinobacteria: A Brief Overview</b> .....	377
Naghmeh Poorinmohammad and Javad Hamed	

Javad Hamedí and Joachim Wink

Actinobacteria, as one of the largest bacterial phyla, is a dominant group of microorganisms being widely distributed in various terrestrial and aquatic ecosystems. These Gram-positive, high G+C content bacteria have received much attention in terms of studying its biology, majorly as they have been found to be tremendously potent in producing medically and industrially relevant secondary metabolites. This extensive secondary metabolism has led to the discovery of more than 120 antibiotics, different enzymes, enzyme inhibitors, and many other useful products from actinobacterial sources, discussion on which is one of the main focuses of the current book.

Apart from being designated as a controversial kind of microorganism when first discovered, namely, prokaryotic equivalent of fungi, the primary motivator for increasing the interest for biological basic studies on actinobacteria was the discovery and observation of their vast biotechnologically related potentials. That is to say, although being popularly accepted as a basic science, microbiology generally implements a bottom-up approach in studying microorganisms (including actinobacteria), and this seems to be an inherent property of the field. This is while other well-developed basic sciences such as *botany* or *zoology* have been basically formed on the basis of a top-down approach in which the objects being studied are considered, regardless to their importance in terms of application and consequently their potentials will be revealed after gaining an evenly developed knowledge.

The mentioned approach of microbiology consequently has resulted in an unbalanced and uneven development of basic biological knowledge for microorganisms,

---

J. Hamedí (✉)

Department of Microbial Biotechnology, School of Biology and Center of Excellence in Phylogeny of Living Organisms, College of Science, University of Tehran, Tehran, Iran

Microbial Technology and Products Research Center, University of Tehran, Tehran, Iran  
e-mail: [jhamedí@ut.ac.ir](mailto:jhamedí@ut.ac.ir)

J. Wink

Helmholtz Center for Infection Research, Braunschweig, Germany



having more basic information on those showing more application potencies. This pattern is also true in case of actinobacteria.

Accordingly, the understanding of the actinobacterial biology has been based on merely a few model organisms which are either medically important pathogens such as *Mycobacteria* or biotechnologically relevant producers including mainly *Streptomyces*. This is while there are many other actinobacterial groups with insignificant basic biological knowledge of which *Coriobacteriaceae*, *Catenulisporales*, the class *Thermoleophila*, as well as many other taxa within this group can be named. However, it is also important to note that the yet-existing limitations in turning uncultured actinobacteria to cultivable ones are another shortcoming in understanding these bacteria which must be taken into account. Yet the first steps to better and fully understand these bacteria to uncover their further potentials owe to addressing the problem of unevenly distributed basic biology of actinobacterial members.

Even though the taxonomic characterization has a very long tradition starting with its morphological features, today there are many open questions which also cannot be easily solved by sequence analysis of the organisms. Currently, many groups have their focus on the molecular characterization and the expressed features are often neglected. As the taxonomic description of novel actinobacteria can only be done by the use of a polyphasic approach, one aim of the book is to give an overview on the methods which can be used in the laboratory, even the more classic ones.

The search for novel antibiotics came into focus again in the last years because of the resistance development of many bacteria especially the nosocomial ones and the upcoming role of the so-called neglected diseases. The role of actinobacteria in this search for the future is still open, but the editors think that this class of bacteria is still one of the most promising groups even in the future. Therefore, we need more understanding of the biological role, the environment, and the bacterial communities for the isolation and identification of potential metabolite producers in the nature. Also the presentation of a straightforward identification procedure of interesting isolates is very important.

In this regard, the chapters of the present book are intended to provide a comprehensive view on the currently available issues relating to the biology and biotechnology of actinobacteria to hopefully depict and introduce the correct path for the development of a significant balanced understanding of the biology of this bacterial group.

Topics reviewed include all aspects of actinobacteria biology from their cellular properties, physiology, taxonomy, and genetics to their ecology and symbiosis. Despite these, their most important biotechnological traits are reviewed in the closing chapters to better elucidate the targeted trajectory which must be acquired to comprehensively cover the knowledge on actinobacteria as one of the most important bacterial phyla in medicine, industry, environment, and energy disciplines. As the final chapter of this book, the role of rapidly progressing omics data analysis and computational tools in the study of actinobacteria is also reviewed at a glance to not only stay synchronized with the novel paradigms of the post-genomic era of biology

---

but also to introduce these tools as efficient implementations to address the mentioned problem of unbalanced knowledge of actinobacteria in a time- and cost-effective manner.

Hopefully, the book will be of particular value to basic microbiologists and biotechnologists to unravel the great world of actinobacteria as well as bioinformaticians and molecular biologist who are trying to exploit biological data to find and address the existing biological problems with the aid of, namely, post-genomics approaches.

Javad Hamedi and Naghmeh Poorinmohammad

---

## 2.1 Diversity of Cell Morphology in Actinobacteria

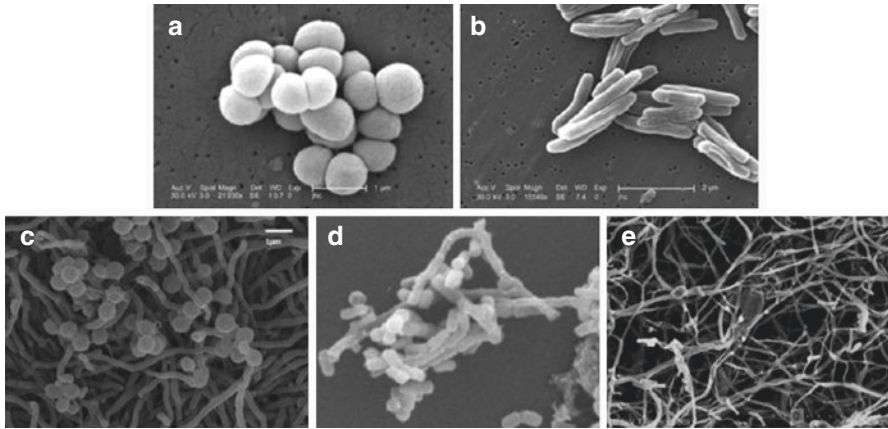
Encompassing more than 200 genera, actinobacterial members display remarkable variation in terms of cell morphology ranging from cocci in *Micrococcus* (Fig. 2.1a), rods in *Mycobacterium* (Fig. 2.1b), branched hyphae bearing spores such as *Micromonospora* (Fig. 2.1c), and mycelia that fragment into coccid and rod-shaped cells in *Nocardia* (Fig. 2.1d) to those actinobacteria which are produced from branched aerial hyphae of 0.5–2  $\mu\text{m}$  in diameter like *Streptomyces* (Fig. 2.1e) (Qinyuan Li et al. 2016). It should be noted that in most cases, the actinobacterial life cycle presents different morphologies such as in *Arthrobacter* sp. which is depicted in Fig. 2.2.

Furthermore, depending on the culture condition, the cell morphology can differ. Accordingly, *Acidothermaceae* grows as slender filaments when the carbon source is glucose or cellobiose, and it grows as short rods when the carbon source is cellulose or xylan (Rosenberg et al. 2014).

Actinobacteria are currently classified and characterized using a polyphasic approach in which the microscopic morphological characteristics are of important indices. However, morphological profile cannot be often “exclusively” attributed to a specific actinobacterial taxon due to the high variation (Girard et al. 2013). For instance, members of the family *Actinomycetaceae* generally show properties such as Gram-stain-positive, straight or slightly curved rods some of which tend to form

---

J. Hamedi (✉) • N. Poorinmohammad  
Department of Microbial Biotechnology, School of Biology and Center of Excellence in Phylogeny of Living Organisms, College of Science, University of Tehran, Tehran, Iran  
Microbial Technology and Products Research Center, University of Tehran, Tehran, Iran  
e-mail: [jhamedi@ut.ac.ir](mailto:jhamedi@ut.ac.ir)



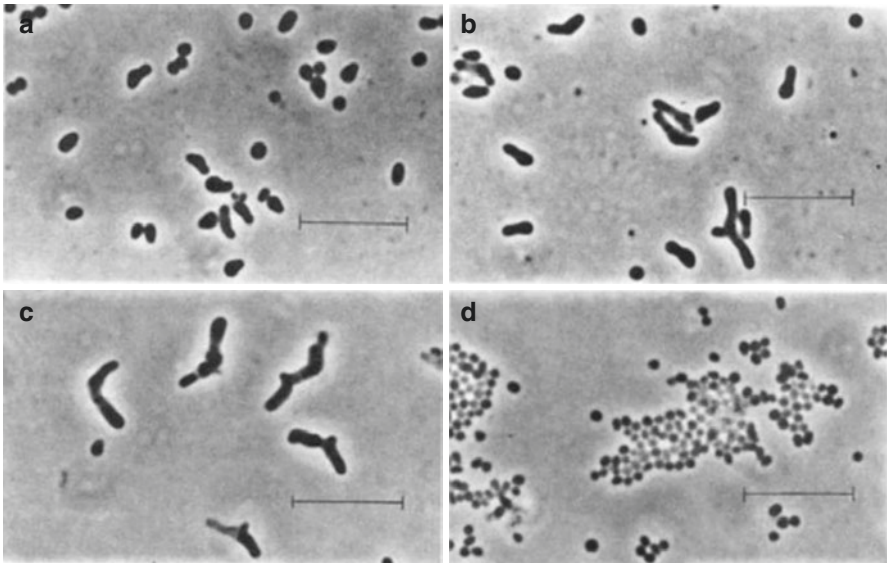
**Fig. 2.1** Scanning electron microscope (SEM) images of (a) cocci of *Micrococcus luteus* (from Centers for Disease Control and Prevention (CDC), Public Health Image Library (PHIL), ID#:9761), (b) rods of *Mycobacterium tuberculosis* (from CDC, PHIL, ID#:9997), (c) branched hyphae of *Micromonospora schwarzwaldensis* (Gurovic et al. 2013), (d) fragmenting mycelia of *Nocardia asteroides* (Ribeiro et al. 2008), and (e) branched aerial hyphae of *Streptomyces mangrovisoli* (Ser et al. 2015)

branched filaments in which fragmentation occurs and rod-shaped or coccoid forms appear. However, the genus *Mobiluncus* (Fig. 2.3a) within this family exclusively exhibits curved, non-branching rods with which stains Gram-variable to Gram-negative although they possess a multilayered Gram-positive cell wall without an outer membrane (Hoyle and McCartney 2012). Some others form pleomorphic rods that occur singly or in many-celled chains or clumps; thus, they are not filamentous or spore forming such as the family *Bifidobacteriaceae* (Fig. 2.3b) (Rosenberg et al. 2014).

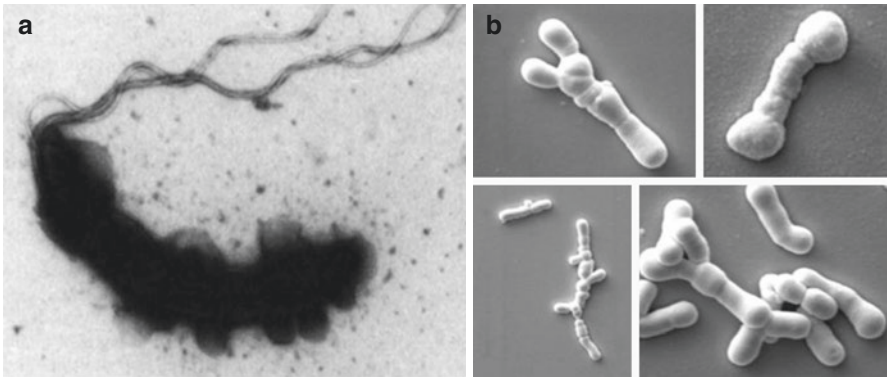
Table 2.1 summarizes the distribution of overall cell shape observed in the most-studied actinobacterial families.

### 2.1.1 Mycelium

Mycelial actinobacteria, e.g., members of *Streptomyces* genus, have a complex life cycle, which is considered in Chap. 3 in detail. Generally, there are two types of mycelia being developed by actinomycetes: substrate and aerial mycelia. Substrate or vegetative mycelium developed from the outgrowth of a germinating spore which grows on the surface of the culture medium to absorb nutrients. Some of these structures can produce pigments responsible for the colors of the substrate and aerial mycelia which



**Fig. 2.2** Different morphological traits of *Arthrobacter globiformis* (a) after 6 h (rod to cocci), (b) after 12 h, (c) after 24 h, and (d) after 3 days (cocci). Bars = 10  $\mu\text{m}$  (from Jones and Keddie 2006)



**Fig. 2.3** Specific morphology of some actinobacteria (a) curve rods of *Mobiluncus curtisii* subsp. *curtisii* BV345-16 (here the flagella is also shown) (from Spiegel and Roberts 1984) and (b) different micrographs of pleomorphic bifidobacteria isolates (from Awasti et al. 2016)

also can be used for the identification of actinobacteria. Aerial hyphae, as the name denotes, grow into the air when the vegetative mycelium develops to a certain stage and will develop a reproductive hyphae producing spores. The aerial hyphae are enclosed in a fine sheath which does not exist in substrate mycelia (Ensign 1978).

**Table 2.1** The distribution of cell morphology among actinobacterial families (Data are collected from the books “Bergey’s Manual of Systematic Bacteriology” and “The Prokaryotes” as well as the web site of “List of prokaryotic names with standing in nomenclature (LSPN)” through [www.bacterio.net](http://www.bacterio.net), accessed August 2016)

Actinobacterial members		Cell shape			
Family	Number of genera within the family	Rod	Cocci	Rod-cocci	Filamentous
Acidimicrobiaceae	5	*		*	*
Acidothermaceae	1	*			*
Actinomycetaceae	8	*	*	*	*
Actinospicaceae	1				*
Beutenbergiaceae	4	*	*		
Bifidobacteriaceae	7	*			
Bogoriellaceae	3			*	
Brevibacteriaceae	1	*	*		
Catenulisporaceae	1	*	*		*
Cellulomonadaceae	6	*		*	*
Conexibacteraceae	1	*			
Coriobacteriaceae	14	*		*	
Corynebacteriaceae	4	*			
Cryptosporangiaceae	2				*
Demequinaceae	2	*			
Dermabacteraceae	4			*	
Dermacoccaceae	11			*	
Dermatophilaceae	5		*	*	
Dietziaceae	1	*	*	*	
Euzebyaceae	1	*			
Frankiaceae	2				*
Gaiellaceae	1	*			
Geodermatophilaceae	3				*
Glycomycetaceae	3				*
Iamiaceae	2	*		*	*
Intrasporangiaceae	23	*	*		*
Jiangellaceae	2				*
Jonesiaceae	1		*		
Kineosporiaceae	5	*	*		*
Microbacteriaceae	42	*	*		*
Micrococcaceae	15	*		*	
Micromonosporaceae	32				*
Mycobacteriaceae	2	*			
Nakamurellaceae	3		*	*	
Nitriliruptoraceae	1		*		
Nocardiaceae	8	*	*	*	*
Nocardiodaceae	9	*	*		*

**Table 2.1** (continued)

Actinobacterial members		Cell shape			
Family	Number of genera within the family	Rod	Cocci	Rod-cocci	Filamentous
Nocardiopsaceae	8				*
Patulibacteraceae	1	*			
Promicromonosporaceae	7	*	*	*	*
Propionibacteriaceae	17	*	*		
Pseudonocardiaceae	31				*
Rarobacteraceae	1	*			
Ruaniaceae	2		*	*	
Rubrobacteraceae	1	*	*		
Sanguibacteraceae	1	*			
Segniliparaceae	1		*		
Solirubrobacteraceae	1	*			
Sporichthyaceae	1				*
Streptomycetaceae	10				*
Streptosporangiaceae	13				*
Thermoleophilaceae	1	*			
Thermomonosporaceae	6				*
Tsukamurellaceae	1	*		*	

Actinobacteria form a substrate mycelium in both submerged and solid-grown cultures, while aerial hyphae are differentiated specifically on solid surfaces. There are also exceptions in terms of mycelium formation. For instance, *Sporichthya* sp. produces short chains of aerial mycelium dividing into motile spores on an agar medium held by the holdfast, but no substrate mycelium formation is observed. The family *Micromonosporaceae* is also identified to develop extensive substrate mycelium while producing rudimentary aerial hyphae, or in some cases, no aerial mycelium is developed. Other actinobacterial taxa with absent aerial mycelium include some *Mycobacteria*, *Kineosporia*, and *Rhodococci* as well as the genus *Intrasporangium* and *Tsukamurella spumae* (O’Leary 1989; Rosenberg et al. 2014).

It is important to note that the morphological differentiation of actinobacteria, especially those with more extensive morphological differentiation such as *Streptomyces*, is tightly regulated and controlled by a truly organized mechanism through relevant genes. For more details regarding the regulation and morphogenetics, see Chap. 3.

### 2.1.2 Resistant Form of the Cells

Bacterial cells possess various differentiation states by which they form resistant non-vegetative cells as survival strategies under environmental challenges and unfavorable conditions. Accordingly, different resistant forms of bacterial cells are

observed such as endospores mainly in Bacilli and Clostridia, exospores which are as durable as endospores but form outside by growing or budding out from one end of the cell, cysts of *Azotobacter*, resting forms in the non-spore-forming *Arthrobacter*, and conidia in actinobacteria. Endospores are extremely resistant to heat ( $>100^{\circ}\text{C}$ ), many chemicals (i.e., acids, bases, alcohol, chloroform), desiccation, and radiation due to the spore's inherent properties such as high concentration of specific DNA-protecting proteins as well as the dehydration of the cytoplasm and impermeability of the endospore coat. *Azotobacter* species, the diazotroph Gram-negative Proteobacteria famous for their biopolymer production in biotechnology, form cysts which, unlike endospores, can only resist desiccation and some chemicals but not the high temperature. The genus *Arthrobacter* forms cyst-like resting cells with extremely lowered metabolism under unfavorable environments such as in response to conditions of severe carbon and energy deficiency.

The actinobacterial "conidia," which are commonly called spores, are part of the reproductive process, although they are also capable of surviving for long periods of time. Thus, conidia are involved in both replication and survival, while cysts and spores are merely for survival strategies. Here, we use the more commonly used phrase of "spores" instead of the correct term "conidia" for actinobacterial-resistant form of cell.

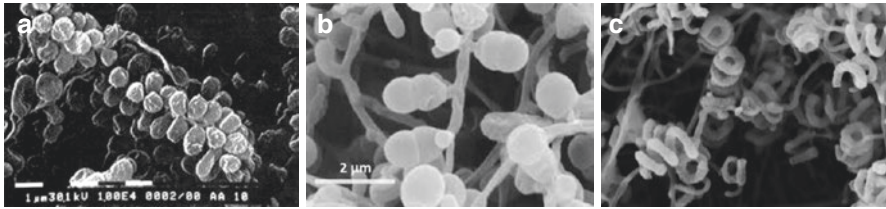
Classic actinomycetes form well-developed substrate mycelia and develop branched aerial hyphae on the vegetative mycelia and can produce spores directly or in the form of sack-like ultrastructures.

The ability of forming such complicated structures (spores, sporangia, and sporangiospore) as well as the pattern of substrate mycelium fracture, the number of spores and their position, the shape of sporangia, and whether the sporangiospore has flagella or not are used in the classification of some actinobacteria.

These spores can be organized as single in *Saccharomonospora* (Fig. 2.4a), bispores in *Microbispora* (Fig. 2.4b), or spiral chains of multiple spores such as in *Streptomyces* (Fig. 2.4c). However, in some genera such as *Nocardia*, *Mycobacterium*, and *Rhodococcus*, the developed mycelia fragment into coccoid or rod-shaped elements.

In general, actinobacterial spores are formed by hyphal origin which is further classified into three subtypes, namely, arthrospores (subdivision of sheathed hypha) as in *Streptomyces*, *Actinopolyspora*, *Nocardia*, etc.; aleuriospore (subdivision of sheathless hypha) in *Micromonospora*, *Saccharopolyspora*, etc.; and fragmentation spores of *Rhodococcus*, *Nocardiopsis*, etc. as mentioned before. Some other actinobacteria especially *Frankia* species have special vesicles called sporangia containing whether aplanospores (non-motile) or planospores (motile). Planospores or motile spores can possess a single flagellum per spore (monotrichous) or appear with multiple flagella with different arrangements around the cell. Planospores can be seen in *Sporichthya*, *Ampullariella*, *Spirillospora*, and *Catenuloplanes*. These motile spores possess a kind of smooth surface, while aplanospores can have





**Fig. 2.4** Different spore organization in actinobacteria. (a) *Saccharomonospora glauca* (Greiner-Mai et al. 1988), (b) *Microbispora corallina* (Nakajima et al. 1999), and (c) *Streptomyces* sp. MN 2 (Kumar et al. 2014)

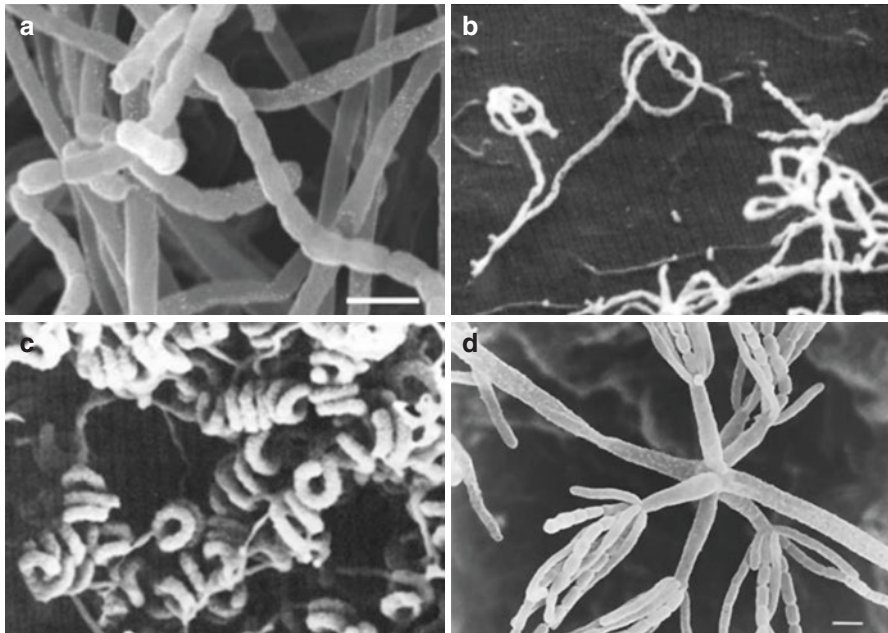
different surface characteristics whether smooth or rough with warty, hairy, spiny, or rugose ornamentations. Aplanospores are also produced by *Micromonospora*, *Streptomyces*, *Actinomadura*, and *Microtetraspora* (Locci 2006).

It must be noted that in some individual genus or even species, two kinds of spores can be formed such as in *Nocardia* which is able to produce both fragmentation spores and arthrospores. On the other hand, spores do not form exclusively on aerial hyphae, and the formation of spores may also originate from the vegetative mycelium that has been observed in *Actinobifida* and some members of *Streptomyces* (Kalakoutskii and Agre 1976).

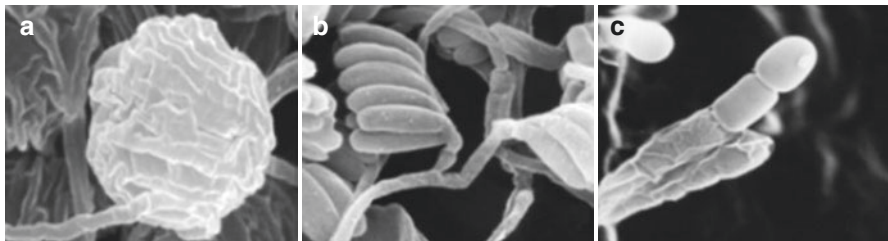
Spores produced in the form of chains are 2 to more than 50 spores long depending on the genus and are thicker than the mycelium when they are arranged in short chains, while long spore chains are equal with the hyphae in diameter (Li et al. 2016). Long spore chains (up to 100 spores) have been observed in *Streptomyces*, *Nocardioides*, *Streptovercillium*, and *Kitasatospora*, and the genera *Actinomadura*, *Sporichthya*, *Catellatospora*, *Saccharopolyspora*, and some *Nocardia* produce short chains of spores (Mayilraj et al. 2006; Taddei et al. 2006; Rosenberg et al. 2014). Long spore chains of *Streptomyces* differ in terms of spatial organization and are classified as rectiflexibile type (Fig. 2.5a), retinaculiaperti type (Fig. 2.5b), spira type (Fig. 2.5c), and verticillati type (Fig. 2.5d) (Qinyuan Li et al. 2016).

Generally, the shape of actinobacterial spores is often spherical, although other shapes may be observed such as cuboid in *Chainia*, oval in *Actinomadura*, or claviform spores of *Dactylosporangium*. Moreover, mature spores usually show a variety of colors such as white, pink, gray, blue, and so on.

Sporangia, the bag-like structures for the development and release of spores, also vary vastly on the basis of shape and size. They are formed whether on substrate or aerial mycelium and can be globose (Fig. 2.6a) (*Spirillospora*, *Streptosporangium*), cylindrical (Fig. 2.6b) (*Planomonospora*, *Planobispora*), claviform (Fig. 2.6c) (*Dactylosporangium*), and in other shapes while they are 2–50  $\mu\text{m}$  with most of them being 10  $\mu\text{m}$  in size (O’Leary 1989).

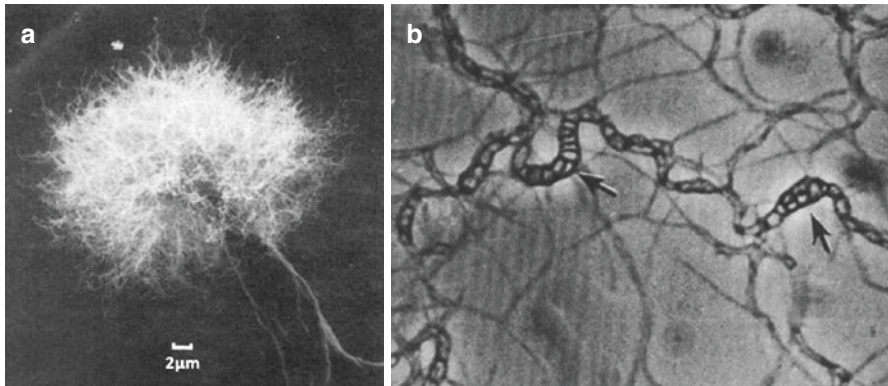


**Fig. 2.5** Morphology of the long spore chains of *Streptomyces* species. (a) *Streptomyces plumbi-resistens* (Guo et al. 2009), (b) *Streptomyces vinaceus* (Ludwig et al. 2012), (c) *Streptomyces hygroscopicus* (Ludwig et al. 2012), and (d) *Streptomyces verticillus* (Produced by Harada and Hamada)



**Fig. 2.6** Sporangia morphology in some actinobacteria. (a) *Spirillospora albida* (Produced by Vobis), (b) *Planomonospora parontospora* (Produced by Hayakawa, Iino, and Nonomura), and (c) *Dactylosporangium fulvum* (Produced by Shomura)

Just like spores, sporangia have different types based on the number of spores. Sporangia with few spores may be called oligosporous sporangia while polysporous ones contain numerous spores as the name denotes. Most of the actinobacterial members forming sporangium produce planospores although exceptions exist as for *Stretosporangium* and *Kutzneria*.

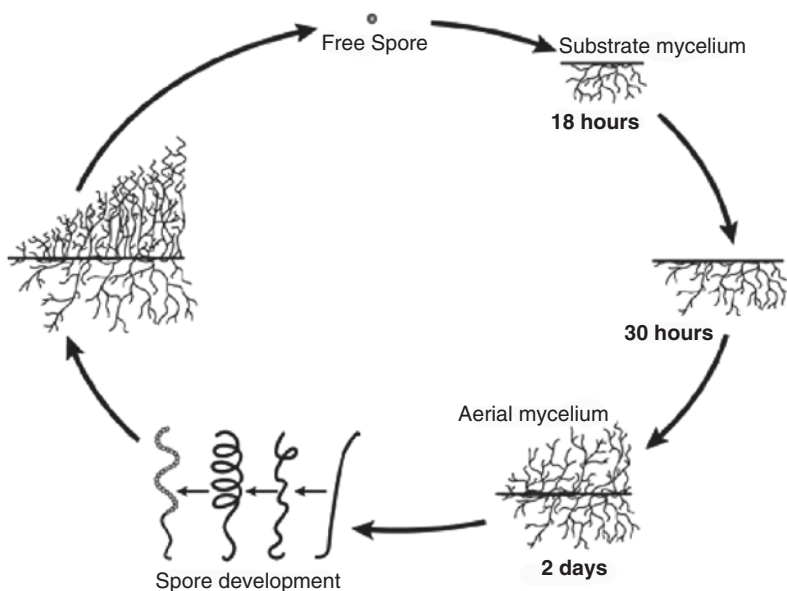


**Fig. 2.7** Sporangia-like structures. (a) Synnemata in *Actinosynnema* (Hasegawa et al. 1978), (b) sclerotia (arrows) in *Chainia barodensis* (Ganju and Iyengar 1974)

Finally, there are other less-studied types of reproductive structures reported in actinobacteria such as columnar hyphal structures called synnemata (Fig. 2.7a) which bear chains of conidia in *Actinosynnema* (Land et al. 2009) and sclerotia (Fig. 2.7b) in some *Streptomyces* and *Chainia* (Subramanian 2016).

Generally, actinobacterial developmental life cycle is uniquely complex, especially in case of actinomycetes which form spores and mycelium. Their life cycle involves coordinated multicellular development with both physiological and morphological differentiation of several cell types as discussed. The life cycle of actinobacteria is specially studied for *Streptomyces*. This genus has been the subject of intense genetic and molecular biology research, while there are little or no information regarding the developmental process of many other actinobacterial members which is an issue to be addressed.

Typically, when a *Streptomyces* spore encounters appropriate conditions in terms of environmental and nutritional factors, it germinates and grows to form the hyphae which then grow by tip extension and further branches into the vegetative mycelium. When conditions become unfavorable, both production of secondary metabolites and morphological differentiation are initiated. In this condition, aerial hyphae break the surface tension and grow into the air and subsequently switch from extension to septation. The aerial hyphae become divided by a developmentally controlled form of cell division into long chains of prespore compartments, which then develop the mature spore (Fig. 2.8). It is important to note that the importance of studying the mentioned features especially in the identification of these bacteria is directedly discussed in Chap. 11.



**Fig. 2.8** *Streptomyces coelicolor* life cycle (From Angert 2005)

## 2.2 Cell Envelope

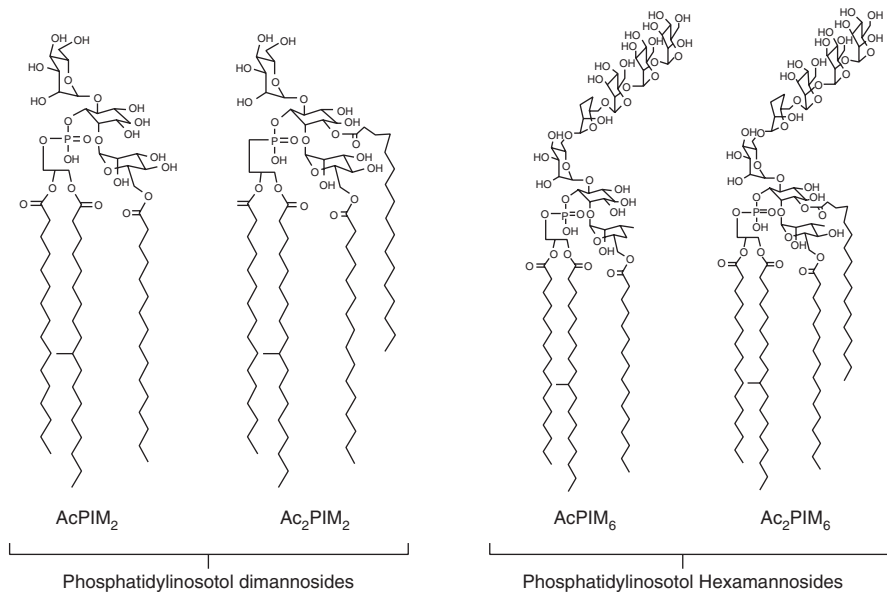
Bacterial cell envelope is acceptably defined as the membrane(s) and other structures that surround and protect the cytoplasm of the bacteria. This multilayered structure is quite complex and serves as an important element in the living and survival of the organism with sophisticated mechanisms (Silhavy et al. 2010).

Apart from determining cell shape and permeability, bacterial cell envelope serves as the interface for interacting with other bacteria, environment, and the host if it is pathogen. Thus, the study of this compartment is of great importance especially in medicine and biotechnologically relevant processes (Braun et al. 2015). Moreover, chemotaxonomy which is shown to be an effective strategy for the classification of actinobacteria is concerned with the distribution of specific chemicals of the actinobacteria cell envelope such as amino acid, sugar, polar lipids, menaquinones, and mycolic and fatty acids (Diagne et al. 2013).

The study of actinobacterial cell envelope is generally limited to the most important pathogenic members such as the distinctive family of *Corynebacteriaceae* including mainly *Mycobacterium*, *Rhodococcus*, and *Nocardia* as well as the biotechnological workhorses within the family like *Corynebacterium glutamicum*. Therefore, in this chapter, these organisms are mostly considered to as model organisms for the study of cell envelope (Fig. 2.11).

## 2.2.1 Plasma Membrane

The plasma membrane of the mentioned bacteria does not differ widely from other bacteria. In the case of this plasma membrane, an unusual lipid named diacyl phosphatidylinositol dimannoside (Fig. 2.8) is reported to be the dominant component of the inner leaflet in *Mycobacteria* which is proved to cause the general drug resistance in this genus due to its effect on the membrane fluidity which slows the influx of the drugs (Bansal-Mutalik and Nikaido 2014). In addition to the conventional plasma membrane which does not differ with other bacteria (comprising mainly phosphatidylglycerol), *Corynebacteriaceae* possess an outer layer of lipids surrounding the cell wall, which is different from the inner membrane, as in Gram-negative bacteria. This means that this unusual property among Gram-positive bacteria gives *Corynebacteriaceae* an extra outer permeability barrier. This outer membrane is an asymmetrical bilayer which is about two times thicker than the plasma membrane in *Corynebacteriaceae* (Brennan and Nikaido 1995), although *Corynebacteria* lack the periplasmic-like space which is present in *Mycobacteria*. The aforementioned thickness is reported to be due to phosphatidylinositol mannosides (PIMs) (Fig. 2.9) of the outer leaflet which are restricted to the members of actinomycetes (Brennan and Nikaido 1995).



**Fig. 2.9** Different types of PIMs.  $AcPIM_2$  monoacyl phosphatidylinositol dimannosides,  $Ac_2PIM_2$  diacyl phosphatidylinositol dimannosides,  $AcPIM_6$  monoacyl phosphatidylinositol hexamannosides,  $Ac_2PIM_6$  diacyl phosphatidylinositol hexamannosides

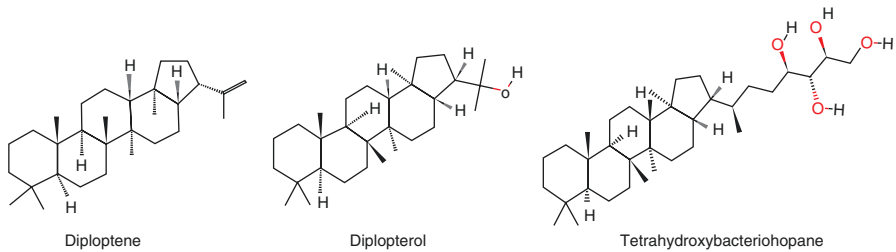
The inner layer of the asymmetrical outer membrane majorly consists of mycolic acid (2-alkyl branched, 3-hydroxy long-chain fatty acids) which is covalently attached to arabinogalactan units in the cell wall. The length of carbon chain in mycolic acid is shorter in *Corynebacteria* than that in *Mycobacteria*, being C<sub>22</sub> to C<sub>36</sub> and C<sub>60</sub> to C<sub>90</sub>, respectively (Schluesener et al. 2005). Rhodococcal mycolic acids are of intermediate length typically with 28–54 carbons in total (Sutcliffe et al. 2010). The outer leaflet is composed of different anchored glycolipids, glycopeptidolipids, sulfolipids, and phospholipids. The mycobacterial phospholipids are mostly the derivatives of phosphatidic acid such as phosphatidylglycerol, phosphatidylethanolamine, cardiolipins, phosphatidylinositol, and PIMs (Brennan and Nikaido 1995). There are also some lipids found in small amounts showing no structural roles in the plasma membrane, but they rather seem to have functional effects as sugar donors, among which the two well-studied examples are polyprenol phosphomannose (PPM) and decaprenol phosphoarabinose (DPA). They are donors for mannose and arabinose, respectively (Crellin et al. 2013).

The polysaccharides of the outer membrane are primarily composed of a high-molecular-mass glucan and arabinomannans (Puech et al. 2001).

Since the outer membrane exerts a permeability barrier in this family, substance exchange, especially for water-soluble molecules, along the cell envelope is performed via many specific and nonspecific proteins located in the outer membrane. In *M. tuberculosis*, more than 140 of these proteins are predicted through genome mining, while many of them are still not fully characterized (Song et al. 2008). For instance, the nonspecific protein named MspA is the main porin responsible for the transport of glucose, metal ions, phosphate, and amino acids in *Mycobacteria* which possess an octameric 16-stranded  $\beta$ -barrel structure (Niederweis et al. 1999). The anion channel PorB of *Corynebacterium glutamicum* and the cation channel Rv1968 in *Rhodococcus jostii* are other examples of such porins (Sutcliffe et al. 2010). The elucidation of the structure of such porins in pathogenic actinobacteria will help in finding inhibitors as a drug target to fight against the bacterium; however, only few of them are characterized in terms of 3D structure. Additionally, there are other types of proteins in the outer membrane which are responsible for the transport of low-abundance solutes for which the porin pathway is not efficient (Niederweis et al. 2010). Interestingly, since *Mycobacteria* can use lipids as carbon source for growth, there are also protein channels found in the outer membrane such as Mce4 which enables cholesterol to enter the cell (Pandey and Sasseti 2008).

Other membrane-associated components are a few types of polyterpenes shown to be associated with the protection against photolytic damage. Mycobacterial carotenoid is one of these products which causes the yellowish orange color in *M. kansasii* (Brennan and Nikaido 1995). There are also respiratory isoprenoid quinones in the cytoplasmic and mitochondrial membrane found to date merely in actinobacteria. The number of isoprene units and hydrogenated double bonds in different actinobacteria is of considerable value in the chemotaxonomy of these bacteria (Rousseaux et al. 2001).

As another membrane component, hopanoids, the structurally and biosynthetically similar components to sterols of eukaryotes, can be reviewed for their existence and role in some actinobacteria. Hopanoids are structurally diverse; however, some of the most common structures are illustrated in Fig. 2.10.



**Fig. 2.10** Chemical structure of some common hopanoids

In general, hopanoids or bacteriohopanepolyols (BHPs) are a class of pentacyclic triterpenoids which are generally localized in the cytoplasm, outer membrane, and also in association with other specialized bacterial membranes such as the thylakoid membranes in cyanobacteria and in the vesicle envelope of the root nodule symbionts *Frankia* sp. (Welander et al. 2009; Sáenz et al. 2015). Eukaryotic sterols such as cholesterol are responsible for modulating the membrane order, and hopanoids are shown to perform the same role in bacteria except that the condensing and ordering effect of these components is elucidated to be weaker than that of cholesterol (Poger and Mark 2013), although it significantly contributed in the membrane functionality.

As hopanoid-containing actinobacteria are *Frankia* sp. and the nitrogen-fixing actinomycetes, these triterpenoids are produced in extremely high levels in these bacteria. Hopanoids are the most abundant lipids in the nitrogen-fixing vesicles of this genus (diazovesicles which will be discussed later in this chapter) and are believed to be efficient in protecting the nitrogenase against oxygen by acting as a major physical barrier as they represent up to 87% of the total vesicle lipids detected (Nalin et al. 2000). Hopanoids which are produced in nearly half of all analyzed bacterial species have proven to be physiologically important due to their critical role in membrane dynamics during different stresses. For instance, the membrane condensing hopanoids of *Streptomyces coelicolor* is proposed to have possible roles in stress alleviation in aerial mycelium by diminishing water permeability across the membrane (Poralla et al. 2000) although they are verified to be not essential for growth when the gene for hopanoid biosynthesis was mutated (Seipke and Loria 2009).

## 2.2.2 Cell Wall

Actinobacteria possess a cell wall containing peptidoglycan (PG) layer of 20–80 nm thickness. Twenty percent of the cell dry weight is represented by the cell wall of which around 60% is the PG weight. The remaining weight is due to the presence of different macromolecules such as lipids, polysaccharides, proteins, and teichoic acids in which some of them are free while others are attached to the PG.

Conventionally, bacterial PG is a polymer containing  $\beta$ 1–4 linked *N*-acetylglucosamine (NAG) and *N*-acetylmuramic acid (NAM) units as well as a chain of amino acids connected to NAM. In actinobacteria, variations in the amino acid sequence of these peptide chains together with their mode of cross-linkage give clues for their classification.

The amino acid of position 3 in the peptide chain is the most helpful index for the classification of actinobacteria based on cell envelope compositions. This position can be occupied with *meso*- and *LL*-diaminopimelic acid, *L*-ornithine, *L*-lysine, and *L*-diaminobutyric acid (Roy et al. 2007).

Apart from peptidoglycan, the cell wall of actinobacterial members also includes arabinogalactan (AG), lipomannan, and lipoarabinomannan. Many of the sugar polymers of the cell wall, such as AG, are important due to their role in immunological reactions of the host, when talking about pathogenic actinobacteria. There are several antibiotics targeting AG such as ethambutol, since the absence or defect in AG is verified to cause growth defects (Alderwick et al. 2006; Seidel et al. 2007).

The cell wall core of *Mycobacteria* is composed of PG covalently attached to AG via phosphoryl-Nacetylglucosaminosyl-rhamnosyl linkage units (PGlcNAc-Rha), while AG esterifies to long-chain mycolic acids which is the main component of the inner leaflet of the outer layer. This is while in other Gram-positive bacteria, wall teichoic acids (WTA) are covalently attached to PG (Grzegorzewicz et al. 2016).

Although lipoteichoic acid (LTA) is suggested to be available merely in Firmicutes, they are reported in two actinobacterial genera, namely, *Agromyces* and *Streptomyces* (Potekhina et al. 1982; Greiner-Mai et al. 1987), as well as in *Thermobifida fusca* which was suggested to have roles in the cell envelope homeostasis (Rahman et al. 2009).

Another major compartment of actinobacterial cell wall is teichuronic acids, the heteropolymeric polysaccharides composed of a uronic acid along with amino sugars and neutral monosaccharides which are linked to a polymer of whether amino acids or glycerol phosphates (Tul'skaya et al. 2011). They are of common cell wall components of actinobacteria such as *Propionibacterium*, *Corynebacterium*, *Catellatospora*, *Actinoplanes*, *Streptomyces*, and *Kribbella* (Tul'skaya et al. 2011).

### 2.2.3 Surface Layer and Capsule

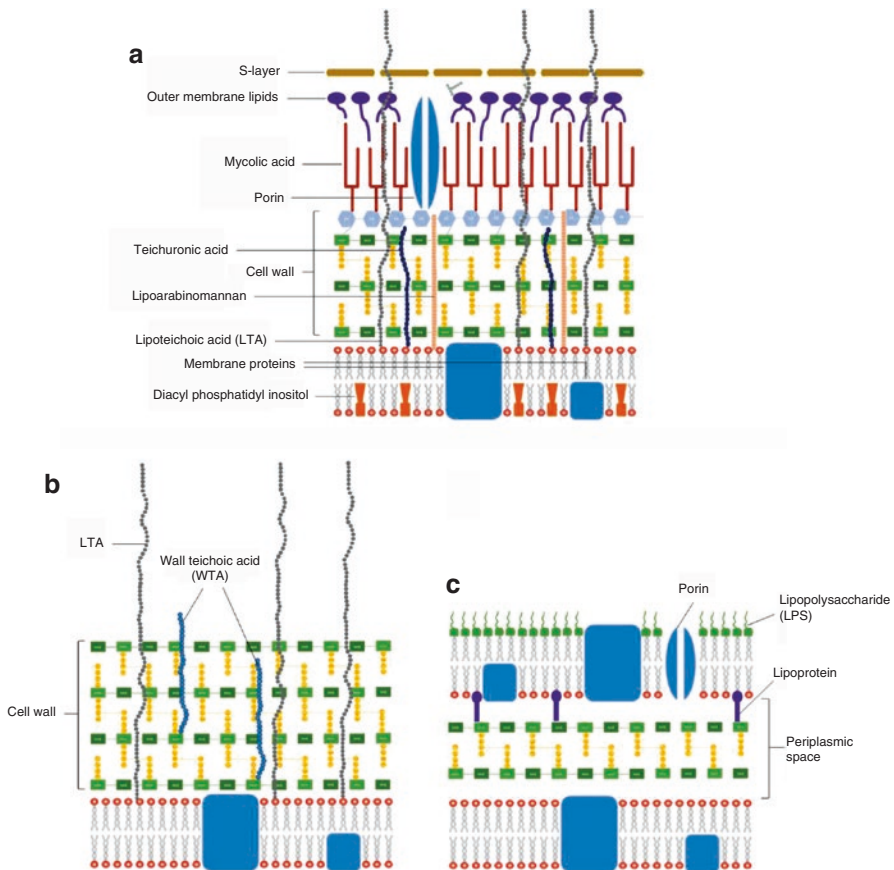
Surface layer or S-layer is a crystalline monomolecular outermost layer of cell envelope composed of identical proteins or glycoproteins found in the cell envelope of various bacterial taxonomic groups as well as in some members of actinobacteria. Cells equipped with S-layer can efficiently withstand the osmotic pressure. Moreover, it is proposed that the existence of this layer which serves as the interface between the cell and its environment would give the functionality as a selective sieve to the cell by which the passage of low-molecular-weight solutes is allowed while excluding large molecules or structures (such as viruses) (Guerrero 2000).

*C. glutamicum* possesses an S-layer composed of PS2 proteins. PS2 is a 52 kDa protein which forms an S-layer with hexagonal lattice symmetry (Peyret et al. 1993). This layer has been shown to give the bacterium an extreme resistance to protease and detergents. The S-layer is attached to the cell wall majorly via tight hydrophobic interactions. The C-terminal segment of PS2 is hydrophobic, and any defect in this segment has been shown to result in the secretion of this protein to the medium. As a biotechnological point of view, since bacteria with S-layer express the relating protein in high amounts and within an efficient expression system, they can be biotechnologically studied and used for heterologous protein expression procedures (Bayan et al. 2003).



*Rhodococcus equi* which is a human and animal pathogen actinobacterium produces capsular polysaccharides which are structurally diverse acidic heteropolysaccharides consisting of acetal-linked pyruvate or lactic acid ether substituents. Other actinobacteria such as *Thermomonospora*, *Arthrobacter*, *Acidothermus*, and *Nitrospirillum* also produce capsules (Rosenberg et al. 2014). Although capsules are not observed by capsule staining, *Actinobaculum* is reported to have a fringelike outer coat external to the cell wall in thin section electron micrographs (Rosenberg et al. 2014).

Some pathogenic *Mycobacteria* also produce capsules as a thick layer in the outermost part of the cell. *M. tuberculosis* and *M. kansasii* possess glucan and protein-containing capsules, while in the case of *M. leprae*, capsule is comprised of phenolic glycolipids (Daffé 2015) (Fig. 2.11).



**Fig. 2.11** The schematic cell envelope of *Corynebacteriaceae*. (a) Gram-positive (b) and Gram-negative cell envelope (c) are also depicted for quick comparison. *Notes:* (1) Dimensions are not fully considered; (2) Gram-positives and Gram-negatives may also contain S-layer; (3) Not all the depicted components in “a” are found altogether in every member of *Corynebacteriaceae* (see text) and many of other actinobacteria, e.g., *Micrococcus luteus* has pattern “b”

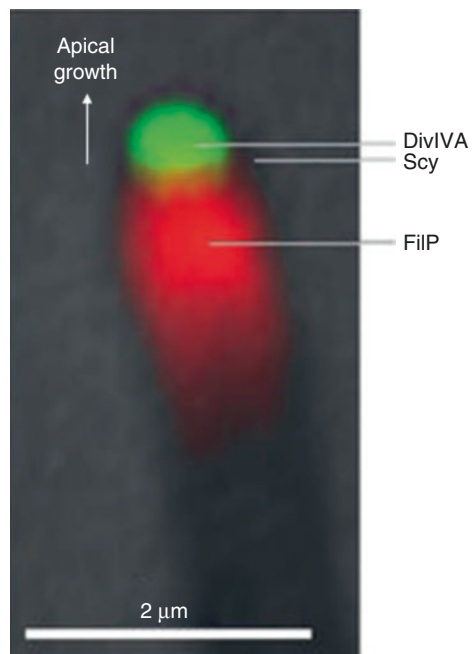
## 2.3 Cytoplasm

### 2.3.1 Cytoskeleton

One of the major components of bacterial cytoplasm is the “cytoskeleton,” which is required for cell shape determination, cell division, and motility (Graumann 2009). Cytoskeletal proteins are ubiquitous among bacteria such as FtsZ, MreB/Mbl, and crescentin which are the homologues of eukaryotic tubulin, actin, and intermediate filaments, respectively, as well as unique bacterial cytoskeletal proteins such as MinD and bactofilins.

*Streptomyces* have an extremely elaborated cytoskeleton which is more complicated than other bacteria which can be explained by their hyphal growth (Celler et al. 2013). *Streptomyces* possess besides FtsZ and MreB/Mbl a large number of proteins with coiled-coil structural elements. In these bacteria, as well as other Gram-positives, DivIVA exists but with divergent function: in *S. coelicolor*, DivIVA is essential for growth in and localizes to tips to drive apical growth. Here, the over-expression of Scy, a novel coiled-coil cytoskeleton protein which colocalizes with DivIVA, results in establishing growth nuclei for apical growth and branching by sequestering the DivIVA (Lin and Thanbichler 2013). The intermediate filament protein (FilP) localizes near the DivIVA/Scy at the hyphal tip which is proposed to have roles in mechanically controlling the cell shape (Fig. 2.12).

Moreover, actinobacteria possess actinobacterial-specific regulators of FtsZ which is essential in the initiation and development of cell division. FtsW is involved



**Fig. 2.12** Cytoskeleton proteins contributing in the apical growth of *Streptomyces coelicolor* (Adapted from Fuchino et al. 2013)

in the positive regulation of cell division in *Mycobacteria* which does not show any homology with its similar molecules within other bacterial genera. Another example is DivS which suppresses the cell division in *Corynebacteria*. The existence of these specific proteins lacking in other bacteria proves the complexity of the actinobacterial cell division and growth (Letek et al. 2012).

### 2.3.2 Inclusion Bodies

Intracytoplasmic storage compartments called inclusion bodies are widespread among bacteria as well as eukaryotes in which nutrients are accumulated. Lipophilic storage elements represent an efficient form of energy storage since lipids provide more energy than carbohydrates and proteins. This form is found mainly in eukaryotes, although there are few bacteria belonging to the actinobacteria able to store triacylglycerols such as *Mycobacterium* and *Nocardia*. The formation of polyhydroxyalkanoic acid (PHA) inclusions has been also reported in *Nocardia*, *Streptomyces*, *Kineosphaera*, and *Rhodococcus* species (Matias et al. 2009). It is important to note that the granules of PHAs can also be visualized inside the spores (Matias et al. 2009).

Other than PHA and triacylglycerol, other lipids can also be accumulated in actinobacteria. In this regard, *Nocardia* can accumulate glycerides and straight-chain waxes when grown on specific hydrocarbons (Alvarez et al. 1996).

Pallerla et al. have reported the presence of volutin granules, the intracellular storages of complexed inorganic polyphosphate, in *C. glutamicum* which is accumulated for about 18–37% of its total cell volume (Pallerla et al. 2005). The formation of polyphosphate (or metachromatic) granules was previously reported in *C. diphtheriae*, identification of which is performed via staining with toluidine blue or Neisser stains and was a diagnostic tool to discriminate the highly pathogenic *C. diphtheriae* with other corynebacteria (Mac Faddin 1985).

### 2.3.3 Bacterial Microcompartments (BMCs)

BMCs are organelles composed of merely proteins which were previously believed to be phages due to their polyhedral and polygonal shape. They organize diverse metabolisms by encapsulating the relevant enzymes of the metabolic process and are generally used to optimize pathways with toxic or volatile intermediates. When these compartments are lacking, the accumulation of such toxic compounds would result in cellular toxicity. On the other hand, they might diffuse from the membrane to the environment which is unfavorable due to carbon loss. There are different types of well-known BMCs such as carboxysome, 1,2-propanediol utilization (Pdu), and ethanolamine utilization (Eut) microcompartments which diffuse polar molecules such as CO<sub>2</sub>, propionaldehyde, and acetaldehyde, respectively. The latter two compounds are cytotoxic, and these BMCs contain enzymes to produce nontoxic derivatives, while carboxysomes benefit in CO<sub>2</sub> fixation due to bringing high concentrations of relevant enzyme, substrate, and cofactors together (Chowdhury et al. 2014).

It is suggested that the genes encoding BMCs have been subjected to frequent horizontal gene transfer and are thus widespread among the bacterial phyla. BMC gene cluster has been found in many actinobacteria with their relevant enzyme. *Mycobacterium smegmatis* (aldehyde dehydrogenase), *Nakamurella multipartite* (aldehyde dehydrogenase, glutathione-dependent formaldehyde dehydrogenase), and *Solibacter usitatus* (aldehyde dehydrogenase, aldolase, dihydrodipicolinate synthase) are some of these examples (Kerfeld et al. 2010).

---

## 2.4 Other Cellular Structures

### 2.4.1 Vesicles

Gas vesicles are cytoplasmic gas-filled bubbles, whose function is to control the organism's floatation process in aqueous environments. They have been widely studied in cyanobacteria as well as halophilic archaea; they are also reported in actinobacteria distributed in soil and aqueous environments.

The envelope of these vesicles is consisted of a specific type of amphiphilic proteins, namely, gas vesicle proteins (Gvps), whose genes (*gvp*) can be mined in bacteria to predict the presence of gas vesicles. The occurrence of orthologues of the eight essential *gvp* genes has been reported in *Streptomyces* sp. which are verified to be in duplicate or even triplicate in the genomes of these bacteria. However, the actual synthesis of these vesicles should be experimentally validated. The alternative function of Gvps in these bacteria is suggested to be in the osmotic stress response (Shively 2006). Other actinobacterial members such as *Saccharopolyspora erythraea*, *Rhodococcus* sp., and *Amycolatopsis balhimycina* also contain a *gvp* gene cluster. However, the discovery of the "diazovesicles" in *Frankia* sp. is a better example in this regard. *Frankia* are filamentous, nitrogen-fixing actinomycetes which live as microsymbionts in many plant hosts. During nitrogen-limited aerobic conditions in culture and in several types of actinorhizal root nodules, *Frankia* develops stalked, spherical vesicles that develop from hyphal branches. These vesicles are covered with a lipid-abundant layer which mainly consists of hopanoids, and due to this, hopanoid level in *Frankia* is among the highest level among bacteria (Dobritsa et al. 2001). This lipid envelope forms a barrier to oxygen which in turn will protect the nitrogenase enzyme.

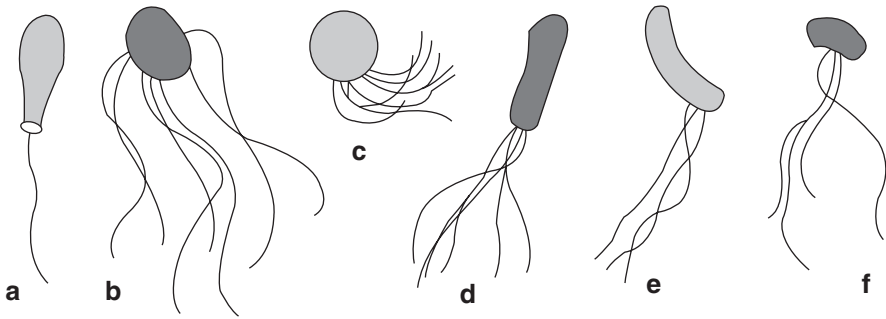
### 2.4.2 Flagella and Pili

As previously mentioned, actinobacterial taxa such as *Actinoplanes*, *Planomonospora*, *Dactylosporangium*, *Ampullariella*, *Spirillospora*, *Planobispora*, and *Dermatophilus* produce motile spores possessing flagella with different numbers and organizations. Although all types of flagellation are found in these bacteria, peritrichous flagellation is rather rare (Kalakoutskii and Agre 1976). Furthermore, flagellated spore released from old sporangia has been identified to be non-motile in *Actinoplanes* sp.; however, the motility can be restored if a suitable carbon and energy source is added to the solution. These bacteria can resynthesize flagella if kept in suitable medium with

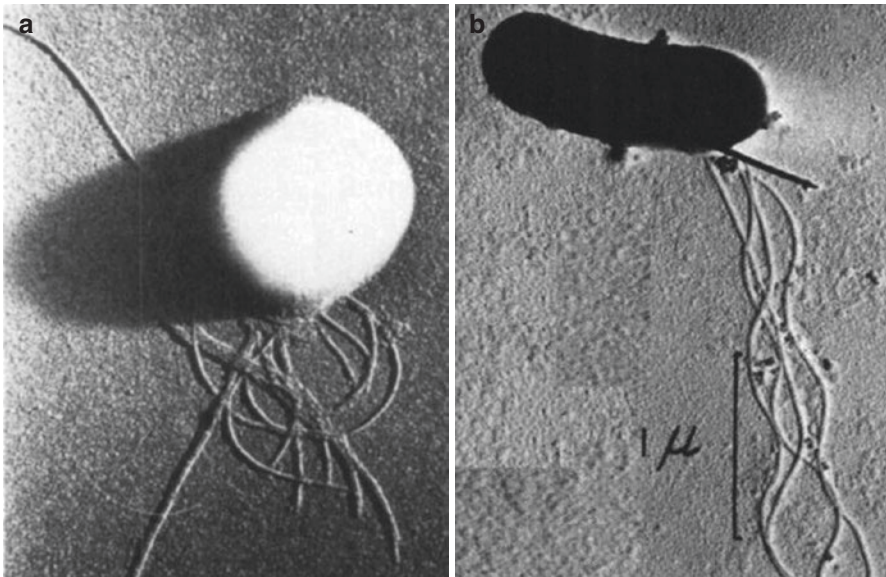
sufficient amino acid and carbon sources when deflagellated via methods such as ultrasound treatment (Kalakoutsii and Agre 1976).

The flagella may appear around the spore through different organizations as can be seen in Fig. 2.13.

As a few examples, *Actinoplanes* sp. have globose motile spores with a polar tuft of flagella (Fig. 2.14a); *Spirillospora*, on the other hand, is reported to have rod-shaped spores, usually slightly bent, with a tuft of flagella in a subpolar location (Fig. 2.14b), and the speed of motility is higher than other motile actinobacterial spores (Higgins et al. 1967). The study of the detailed structure of actinobacterial spore flagella is limited, and further investigations are needed.



**Fig. 2.13** Flagellar organizations of actinobacterial spores. (a) Monopolar monotrichous, (b) peritrichous, (c) polytrichous, (d) monopolar polytrichous (lophotrichous), (e) subpolar polytrichous, and (f) lateral polytrichous



**Fig. 2.14** The motile spores of (a) *Actinoplanes ferrugineus* (Palleroni 1979) and (b) *Spirillospora* sp. (Higgins et al. 1967)

Pili are protein structures that extend from the surface of bacterial cells to allow the bacteria to adhere to their environment (Gerlach and Hensel 2007).

Pili are of important virulence factors of pathogenic bacteria and oral flora since they enable these bacteria to attach the molecules on various host tissues. Moreover, only few Gram-positive bacteria have been reported to possess pili, and if they elaborate these filaments, they have shown to be both shorter and thinner than pili of Gram-negative pathogens (Ton-That and Schneewind 2003). However, there are many members within actinobacteria able to elaborate pili. Pathogen *Corynebacterium diphtheriae* contains adhesive pili on its surface which play prominent roles in its adhesion to different host tissues. There are also genes of the subunits of adhesive pili discovered in *Corynebacterium ulcerans* genome. Pili are important in interbacterial interactions between oral *Streptococci* and *Actinomyces* in the mouth. *A. viscosus* and *A. naeslundii* have two types of pili where one of them is involved in attachment of the bacteria to hard surfaces in the mouth and the other is responsible for the coaggregation reactions with other bacteria (Bowden 1996). *Actinomyces oris* possess pili which comprise two subunits, namely, FimA and FimB, the fimbrillins of shaft and tip, respectively. These subunits can be important targets for exploring novel intervention strategies to control plaque biofilm formation (Mishra et al. 2010).

Different pilus structures can be also formed in a bacterium; *C. diphtheriae* were believed to assemble a pilus structure comprising the subunits SpaA and two minor proteins, SpaB and SpaC; however, later a different pilus type containing the different subunits SpaD, SpaE, and Spa was characterized in this bacteria which are independently assembled and completely different to that of SpaABC (Gaspar and Ton-That 2006).

Generally, pilus subunit molecules (pilins) are localized by non-covalent association within the cell wall envelope specifically PG in Gram-positive bacteria and outer membrane in Gram-negatives. The length of most actinobacterial pili ranged from 0.2 to 3  $\mu\text{m}$  with the diameter of 2–6 nm (Yanagawa and Honda 1976).

## Conclusions

Actinobacteria, the highly evolved Gram-positive bacterial taxon, representing complex life cycle, are abundant in various aqueous and terrestrial environments and have become well adapted to live in these situations via different strategies whether on the genome-scale regulations or cellular structural properties. Although great developments are observed in the field of gene regulation studies as well as studies of actinobacterial applications and biotechnology, the consideration of methods for investigation of basic biological concepts of these bacteria such as their cell morphology and structure needs more attention. Various studies should be conducted to uncover the cell biology of especially less-studied actinobacteria to finally acquire the ability of better understanding their potentials.

## References

- Alderwick LJ et al (2006) Identification of a novel arabinofuranosyltransferase (AftA) involved in cell wall arabinan biosynthesis in *Mycobacterium tuberculosis*. *J Biol Chem* 281(23):15653–15661
- Alvarez HM et al (1996) Formation of intracytoplasmic lipid inclusions by *Rhodococcus opacus* strain PD630. *Arch Microbiol* 165(6):377–386
- Angert ER (2005) Alternatives to binary fission in bacteria. *Nat Rev Microbiol* 3(3):214–224
- Awasti N et al (2016) Probiotic and functional characterization of bifidobacteria of Indian human origin. *J Appl Microbiol* 120:1021–1032
- Bansal-Mutalik R, Nikaido H (2014) Mycobacterial outer membrane is a lipid bilayer and the inner membrane is unusually rich in diacyl phosphatidylinositol dimannosides. *Proc Natl Acad Sci* 111(13):4958–4963
- Bayan N et al (2003) Mycomembrane and S-layer: two important structures of *Corynebacterium glutamicum* cell envelope with promising biotechnology applications. *J Biotechnol* 104(1):55–67
- Bowden GH (1996) *Actinomyces, Propionibacterium propionicus, and streptomyces*. University of Texas Medical Branch at Galveston, Galveston
- Braun V et al (2015) The bacterial cell envelope: structure, function, and infection interface. *Int J Med Microbiol* 305(2):175
- Brennan PJ, Nikaido H (1995) The envelope of mycobacteria. *Annu Rev Biochem* 64(1):29–63
- Celler K et al (2013) Multidimensional view of the bacterial cytoskeleton. *J Bacteriol* 195(8):1627–1636
- Chowdhury C et al (2014) Diverse bacterial microcompartment organelles. *Microbiol Mol Biol Rev* 78(3):438–468
- Crellin PK et al (2013) Metabolism of plasma membrane lipids in *Mycobacteria* and *Corynebacteria*, Lipid Metabolism. INTECH Open Access Publisher. doi:[10.5772/52781](https://doi.org/10.5772/52781)
- Daffé M (2015) The cell envelope of tubercle bacilli. *Tuberculosis* 95:S155–S158
- Diagne N et al (2013) Use of *Frankia* and actinorhizal plants for degraded lands reclamation. *Bio Med Res Int* 2013:1–9
- Dobritsa SV et al (2001) Hopanoid lipids in *Frankia*: identification of squalene-hopene cyclase gene sequences. *Can J Microbiol* 47(6):535–540
- Ensign JC (1978) Formation, properties, and germination of actinomycete spores. *Annu Rev Microbiol* 32(1):185–219
- Fuchino K et al (2013) Dynamic gradients of an intermediate filament-like cytoskeleton are recruited by a polarity landmark during apical growth. *Proc Natl Acad Sci* 110(21):E1889–E1897
- Ganju P, Iyengar M (1974) Micromorphology of some sclerotial actinomycetes and development of their sclerotia. *Microbiology* 82(1):35–48
- Gaspar AH, Ton-That H (2006) Assembly of distinct pilus structures on the surface of *Corynebacterium diphtheriae*. *J Bacteriol* 188(4):1526–1533
- Gerlach RG, Hensel M (2007) Protein secretion systems and adhesins: the molecular armory of Gram-negative pathogens. *Int J Med Microbiol* 297(6):401–415
- Girard G et al (2013) A novel taxonomic marker that discriminates between morphologically complex actinomycetes. *Open biology* 3(10):130073
- Graumann PL (2009) Dynamics of bacterial cytoskeletal elements. *Cell Motil Cytoskeleton* 66(11):909–914
- Greiner-Mai E et al (1988) Taxonomic revision of the genus *Saccharomonospora* and description of *Saccharomonospora glauca* sp. nov. *Int J Syst Evol Microbiol* 38(4):398–405
- Greiner-Mai E et al (1987) Morphological and biochemical characterization and emended descriptions of thermophilic actinomycetes species. *Syst Appl Microbiol* 9(1–2):97–109

- Grzegorzewicz AE et al (2016) Assembling of the *Mycobacterium tuberculosis* Cell Wall Core. *J Biol Chem.* doi:10.1074/jbc.M116.739227
- Guerrero R (2000) Brock biology of microorganisms. Prentice Hall, Upper Saddle River, NJ
- Guo JK et al (2009) *Streptomyces plumbiresistens* sp. nov., a lead-resistant actinomycete isolated from lead-polluted soil in north-west China. *Int J Syst Evol Microbiol* 59(6):1326–1330
- Gurovic MSV et al (2013) *Micromonosporaschwarzwaldensis* sp. nov., a producer of telomycin, isolated from soil. *Int J Syst Evol Microbiol* 63(10):3812–3817
- Hasegawa T et al (1978) New Genus of the Actinomycetales: *actinosynnema* gen. nov. *Int J Syst Evol Microbiol* 28(2):304–310
- Higgins M et al (1967) Flagellated actinomycetes. *J Bacteriol* 93(4):1446–1451
- Hoyles L, McCartney AL (2012) *Mobiluncus* in Bergey's Manual of Systematics of Archaea and Bacteria, Springer: 126–139
- Jones D, Keddie RM (2006) The genus *Arthrobacter*. The prokaryotes. Springer, New York, pp 945–960
- Kalakoutskii L, Agre NS (1976) Comparative aspects of development and differentiation in actinomycetes. *Bacteriol Rev* 40(2):469
- Kerfeld CA et al (2010) Bacterial microcompartments. *Microbiology* 64(1):391
- Kumar V et al (2014) An actinomycete isolate from solitary wasp mud nest having strong antibacterial activity and kills the *Candida* cells due to the shrinkage and the cytosolic loss. *Front Microbiol* 5:446
- Land M et al (2009) Complete genome sequence of *Actinosynnema mirum* type strain (101 T). *Stand Genomic Sci* 1(1):46
- Letek M et al (2012) Cytoskeletal proteins of actinobacteria. *Int J Cell Biol* 2012:1–10
- Li Q et al (2016) Cultural, physiological, and biochemical identification of actinobacteria in *Actinobacteria\_Basics and Biotechnological Application*, INTECH Open Access Publisher. doi:10.5772/61462
- Lin L, Thanbichler M (2013) Nucleotide-independent cytoskeletal scaffolds in bacteria. *Cytoskeleton* 70(8):409–423
- Locci R (2006) *Actinomyces* spores. eLS
- Ludwig W et al (2012) Road map of the phylum Actinobacteria. *Bergey's manual® of systematic bacteriology*. Springer, New York, pp 1–28
- Mac Faddin JF (1985) Media for isolation-cultivation-identification-maintenance of medical bacteria. Williams & Wilkins, Baltimore
- Matias F et al (2009) Polyhydroxyalkanoates production by actinobacteria isolated from soil. *Can J Microbiol* 55(7):790–800
- Mayilraj S et al (2006) *Kitasatospora sampliensis* sp. nov., a novel actinobacterium isolated from soil of a sugar-cane field in India. *Int J Syst Evol Microbiol* 56(3):519–522
- Mishra A et al (2010) The *Actinomyces oris* type 2 fimbrial shaft FimA mediates co-aggregation with oral streptococci, adherence to red blood cells and biofilm development. *Mol Microbiol* 77(4):841–854
- Nakajima Y et al (1999) *Microbispora corallina* sp. nov., a new species of the genus *Microbispora* isolated from Thai soil. *Int J Syst Evol Microbiol* 49(4):1761–1767
- Nalin R et al (2000) High hopanoid/total lipids ratio in *Frankia* mycelia is not related to the nitrogen status. *Microbiology* 146(11):3013–3019
- Niederweis M et al (2010) Mycobacterial outer membranes: in search of proteins. *Trends Microbiol* 18(3):109–116
- Niederweis M et al (1999) Cloning of the *mspA* gene encoding a porin from *Mycobacterium smegmatis*. *Mol Microbiol* 33(5):933–945
- O'Leary WM (1989) Practical handbook of microbiology. CRC press, Boca Raton
- Pallerla SR et al (2005) Formation of volutin granules in *Corynebacterium glutamicum*. *FEMS Microbiol Lett* 243(1):133–140
- Palleroni NJ (1979) New species of the genus *Actinoplanes*, *Actinoplanes ferrugineus*. *Int J Syst Evol Microbiol* 29(1):51–55



- Pandey AK, Sasseti CM (2008) Mycobacterial persistence requires the utilization of host cholesterol. *Proc Natl Acad Sci* 105(11):4376–4380
- Peyret J et al (1993) Characterization of the *mspB* gene encoding PS2, an ordered surface-layer protein in *Corynebacterium glutamicum*. *Mol Microbiol* 9(1):97–109
- Poger D, Mark AE (2013) The relative effect of sterols and hopanoids on lipid bilayers: when comparable is not identical. *J Phys Chem B* 117(50):16129–16140
- Poralla K et al (2000) Hopanoids are formed during transition from substrate to aerial hyphae in *Streptomyces coelicolor* A3 (2). *FEMS Microbiol Lett* 189(1):93–95
- Potekhina N et al (1982) Isolation of lipoteichoic acid from *Streptomyces levoris*. *Mikrobiologiya* 52(3):434–437
- Puech V et al (2001) Structure of the cell envelope of corynebacteria: importance of the non-covalently bound lipids in the formation of the cell wall permeability barrier and fracture plane. *Microbiology* 147(5):1365–1382
- Qinyuan Li XC, Jiang Y, Jiang C (2016) Morphological identification of actinobacteria. *Actinobacteria - Basics and Biotechnological Applications*. DD Dhanasekaran, InTech
- Rahman O et al (2009) Macroamphiphilic components of thermophilic actinomycetes: identification of lipoteichoic acid in *Thermobifida fusca*. *J Bacteriol* 191(1):152–160
- Ribeiro MG et al (2008) Nocardiosis: an overview and additional report of 28 cases in cattle and dogs. *Rev Inst Med Trop Sao Paulo* 50(3):177–185
- Rosenberg E et al (2014) *The Prokaryotes: actinobacteria*. Springer, Berlin, Heidelberg
- Rousseaux S et al (2001) Isolation and characterisation of new Gram-negative and Gram-positive atrazine degrading bacteria from different French soils. *FEMS Microbiol Ecol* 36(2–3):211–222
- Roy S et al (2007) Combining alders, frankiae, and mycorrhizae for the revegetation and remediation of contaminated ecosystems. *Botany* 85(3):237–251
- Sáenz JP et al (2015) Hopanoids as functional analogues of cholesterol in bacterial membranes. *Proc Natl Acad Sci* 112(38):11971–11976
- Schluesener D et al (2005) Mapping the membrane proteome of *Corynebacterium glutamicum*. *Proteomics* 5(5):1317–1330
- Seidel M et al (2007) Topology and mutational analysis of the single Emb arabinofuranosyltransferase of *Corynebacterium glutamicum* as a model of Emb proteins of *Mycobacterium tuberculosis*. *Glycobiology* 17(2):210–219
- Seipke RF, Loria R (2009) Hopanoids are not essential for growth of *Streptomyces scabies* 87-22. *J Bacteriol* 191(16):5216–5223
- Ser H-L et al (2015) Presence of antioxidative agent, Pyrrolo [1, 2-a] pyrazine-1, 4-dione, hexahydro-in newly isolated *Streptomyces mangrovisoli* sp. nov. *Front Microbiol*. 6:854
- Shively JM (2006) *Complex intracellular structures in prokaryotes*. Springer Science & Business Media, New York
- Silhavy TJ et al (2010) The bacterial cell envelope. *Cold Spring Harb Perspect Biol* 2(5):a000414
- Song H et al (2008) Identification of outer membrane proteins of *Mycobacterium tuberculosis*. *Tuberculosis* 88(6):526–544
- Spiegel CA, Roberts M (1984) *Mobiluncus* gen. nov., *Mobiluncus curtisii* subsp. *curtisii* sp. nov., *Mobiluncus curtisii* subsp. *holmesii* subsp. nov., and *Mobiluncus mulieris* sp. nov., curved rods from the human vagina. *Int J Syst Evol Microbiol* 34(2):177–184
- Subramanian N (2016) Studies on the production of sclerotia by antibiotic producing chainiiae
- Sutcliffe IC et al (2010) The rhodococcal cell envelope: composition, organisation and biosynthesis. *Biology of Rhodococcus*. Springer, Heidelberg, pp 29–71
- Taddei A et al (2006) Isolation and identification of *Streptomyces* spp. from Venezuelan soils: Morphological and biochemical studies. *I. Microbiol Res* 161(3):222–231
- Ton-That H, Schneewind O (2003) Assembly of pili on the surface of *Corynebacterium diphtheriae*. *Mol Microbiol* 50(4):1429–1438

- Tul'skaya E et al (2011) Teichuronic and teichulosonic acids of actinomycetes. *Biochem Mosc* 76(7):736–744
- Welander PV et al (2009) Hopanoids play a role in membrane integrity and pH homeostasis in *Rhodopseudomonas palustris* TIE-1. *J Bacteriol* 191(19):6145–6156
- Yanagawa R, Honda E (1976) Presence of pili in species of human and animal parasites and pathogens of the genus *Corynebacterium*. *Infect Immun* 13(4):1293–1295

Javad Hamedi, Naghmeh Poorinmohammad,  
and Reyhaneh Papiran

---

## 3.1 Life Cycle of Actinobacteria

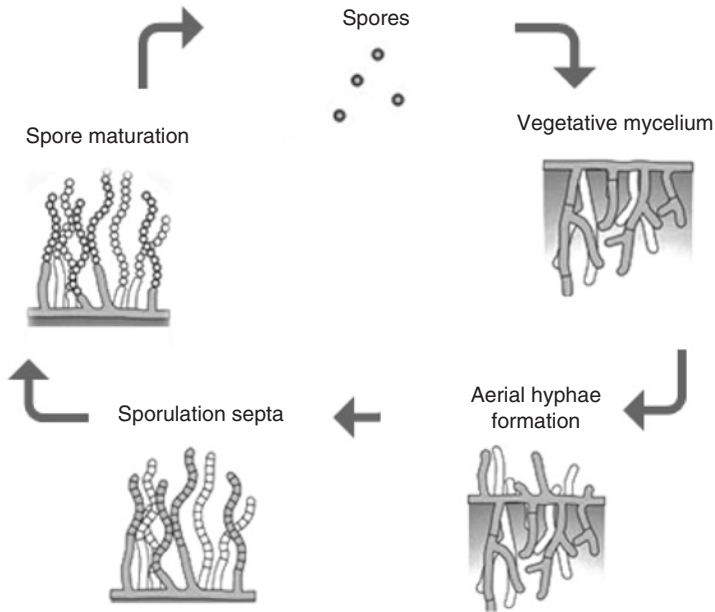
A range of life cycles are observed within actinobacteria which are reasonably unique among prokaryotes. The most distinguishing feature in the developmental cycle of actinobacteria is observed in actinomycetes. This differentiated taxon performs their growth with the formation of branching hyphae which then form a vegetative mycelium, while they disperse through spores that form on specialized reproductive structures called aerial hyphae. Thus, their life cycle resembles in many ways the life cycle of filamentous fungi.

Because of their economic importance in producing secondary metabolites such as antibiotics, the best-studied life cycle is that of the genus *Streptomyces*. When the spore of a *Streptomyces* is in favorable conditions and nutrients, it germinates and tends to form hyphae which grow by tip extension and finally form a substrate mycelium. When sufficient nutrients are not available to the cells or other signals are encountered, many morphological differentiations will occur. For instance, aerial hyphae are formed. Aerial hyphae are then divided into prespore chains through a controlled process of cell division. Mature spores with thick coats are then formed to continue the life cycle (Fig. 3.1).

---

J. Hamedi (✉) • N. Poorinmohammad • R. Papiran  
Department of Microbial Biotechnology, School of Biology  
and Center of Excellence in Phylogeny of Living Organisms,  
College of Science, University of Tehran, Tehran, Iran

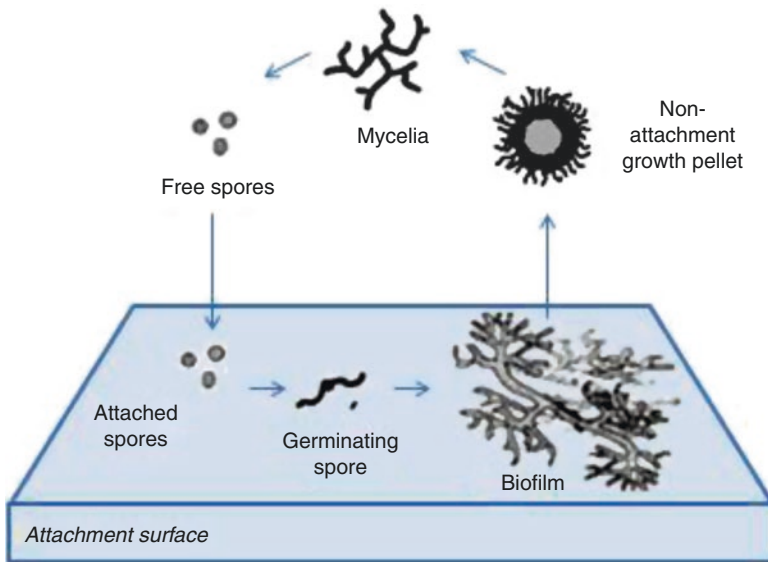
Microbial Technology and Products Research Center,  
University of Tehran, Tehran, Iran  
e-mail: [jhamedi@ut.ac.ir](mailto:jhamedi@ut.ac.ir)



**Fig. 3.1** The life cycle of streptomycetes

There may be some extensions in terms of life cycle stages in different actinomycetes. For instance, in the cellulose-degrading actinobacterium, *Thermobifida fusca*, biofilm formation is reported to apparently represent a major component of its life cycle. *T. fusca* forms biofilm in both nutritive and nonnutritive surfaces (Alonso et al. 2008). The study by Alonso et al. showed that in the life cycle of this actinomycete, cellulose is specifically colonized by aleuriospores, which germinate, grow, and degrade cellulose, ultimately developing into biofilms. The life cycle completes by detachment of cells from the biofilm in the form of aleuriospore or mycelial fragments which can in turn produce mycelial pellets (Fig. 3.2).

There are other types of life cycles within actinobacteria such as the rod-coccus life cycle in rhodococci (Fuhrmann et al. 1997). This life cycle starts with the coccus or short rod stage after which different organisms show various types of succession with more or less complex morphological stages to complete their life cycle. In many, cocci may germinate only into short rods, while others can form filaments as well as show elementary branching. There are also reports on producing extensively branched hyphae in the most differentiated forms. Finally, by the fragmentation of these filaments or rods, cocci can be produced to complete the cycle (Goodfellow et al. 1998).



**Fig. 3.2** Life cycle of biofilm forming *T. fusca*

### 3.2 Differentiation in Actinobacteria

Morphological development as the result of nutrient starvation is well studied in *Streptomyces* genus. Actually, nutritional downshift, especially in the case of nitrogen and carbon sources and guanosine tetraphosphate (GTP), is the most common condition associated with sporulation (Glazebrook et al. 1990; McCormick and Flärdh 2012). Also, genome-wide transcriptome analysis of a group of signaling molecules, called SCBs (*S. coelicolor* butanolides), revealed that  $\gamma$ -butyrolactone system has regulatory effect on morphological differentiation of the bacteria (D'Alia et al. 2011). In addition, microbial interactions such as predation and competition between microorganisms in natural environment can also affect *Streptomyces* differentiation (Pérez et al. 2011).

When adequate aerial biomass is generated through tip extension, aerial growth is stopped by a transmitted signal followed by beginning the sporulation process. The aim of sporulation is increasing the cells' resistance against various chemical and physical stresses. For sporulation, first of all, aerial hypha is subjected to a completely different kind of cell division from vegetative hypha, called as sporulation-specific cell division, a process which is initiated by formation of many symmetrical septa called sporulation septa (Barka et al. 2016;

McCormick and Flårdh 2012). The remarkable difference between vegetative septa, i.e., cross walls, and sporulation septa is the degree of cell separation that resulted from each form of septa. Cross walls lead to physically unseparated cells, forming a multicellular structure of bacteria, like channels containing connected compartments. In contrast, a complete separation of cells is observed by sporulation septa (Jakimowicz and van Wezel 2012).

Spore maturation occurred after sporulation septation. During spore maturation, a thick spore wall is formed through the inside assembling of the prespore. In addition, some nucleoid-associated proteins are involved in prevention of DNA spore from damages to maintain its integrity. The last event in prespore maturation is producing a pigment such as the gray color pigment in *S. coelicolor* (McCormick and Flårdh 2012).

### 3.2.1 Aerial Growth

In many actinomycetes, vertically developing filaments may be observed after germ tube extrusion and mycelia formation, which is called aerial hyphae. The network of aerial hyphae then forms a cover on the colony surface of these bacteria. As previously mentioned, aerial hyphae break the surface tension and escape the environment in which vegetative mycelium was formed and grows out to the air as the name denotes. This structure will be divided into chains of immature spores under a tight and complex controlled cell division. The matured spores then can spread and form mycelia.

Aerial growth in actinomycetes is directly dependent on the nutritional situation as well as the type of mechanical support. Cannibalism of the mycelium biomass from which the emerging aerial hyphae are being formed is one of the most important sources of nutrients which require extracellular protease cascade activation. This will lead to the conversion of millions of spores from a few milligrams of the vegetative mycelium which is a reasonable strategy to survive. On the other hand, the physical support on which the hyphae can grow is provided by some amphipathic proteins and peptides secreted from the cells and is assembled on the surface of the aerial hyphae. Of these proteins, chaplins and rodlins can be named as well as SapB and SapT peptides to fulfill the requirement of correct aerial growth which is described below (Capstick et al. 2007; Ekkers et al. 2014).

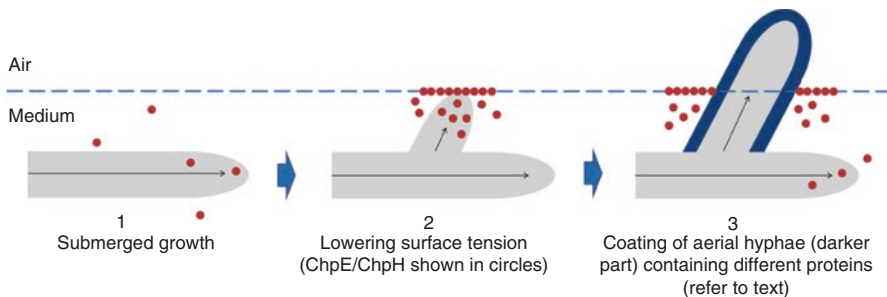
The orientation of aerial growth into the air is aided by a hydrophobic sheath covering the aerial hyphae called the rodlet layer which does not exist in vegetative mycelia. Rodlet layer is composed of paired rods with 8–12 nm in width and up to 450 nm in length. This layer is proved to be very similar to those found on the surfaces of aerial structures of filamentous fungi and is made from self-assembly of

proteins called hydrophobins. This coat together with surfactant materials such as SapB and SapT produced by aerial hyphae helps its growth from aqueous environment into the air (Claessen et al. 2004).

In a rich medium, but not minimal ones, SapB and SapT, non-antibiotic lanthionine-containing peptides, are produced in different actinomycetes species and function as a biosurfactant necessary for aerial growth. However, during the development on either minimal or rich medium, chaplins which are a group of eight secreted, surface-active proteins (ChpA-H) are produced in *Streptomyces coelicolor* (Elliot et al. 2003). It is reported that both the Sap peptides and chaplin proteins are needed for normal aerial hyphae formation on rich medium by exerting their surface tension reduction activity; however, the interplay of these two biosurfactant groups should be revealed (Capstick et al. 2007). Other than their important role in aerial hyphae formation, chaplin proteins have also been reported to affect the ultrastructure of the rodlet layer (Di Berardo et al. 2008).

Generally, a brief model of aerial growth in *S. coelicolor* and the role of hydrophobin proteins/peptides are as follows: (1) submerged growth of mycelium in the culture medium secretes ChpE and ChpH which in turn dramatically decrease the water surface tension; (2) the newborn hyphae emerge and start to produce ChpA-H which will be assembled as an insoluble film at the position where the hyphal cell wall and air phase meet; and (3) the hydrophobic chaplin layer further induces the formation of the ultrastructure of the rodlet layer by rodlin proteins (RdlA and RdlB) (Claessen et al. 2003) (Fig. 3.3).

It is important to note that the aerial growth in actinomycetes is performed by apical extension through the addition of newly synthesized wall material to the tip of the hyphae (Gray et al. 1990). The initiation of new branches on the vegetative mycelium and later this apical growth is mainly driven by the function of directed DivIVA which is a cytoskeletal-like protein reported to have several roles in Gram-positive bacteria such as in polar growth, cell division, and chromosome segregation (Kaval and Halbedel 2012). This coiled-coil protein localizes at the pole of the



**Fig. 3.3** Aerial growth in *S. coelicolor* with the help of chaplins and rodlins

hyphae and functions as a polar recruitment factor. The so-called polarisome formed at the tip of the hyphae by the aid of DivIVA is then broken off to form daughter polarisomes which in turn determine the next position for the growth of other new emerging hyphae. In other words, newborn polarisome is left behind and in turn will recruit more DivIVA proteins. As the daughter polarisome reaches a specific size dose, the new branch will start to grow (Flårdh et al. 2012).

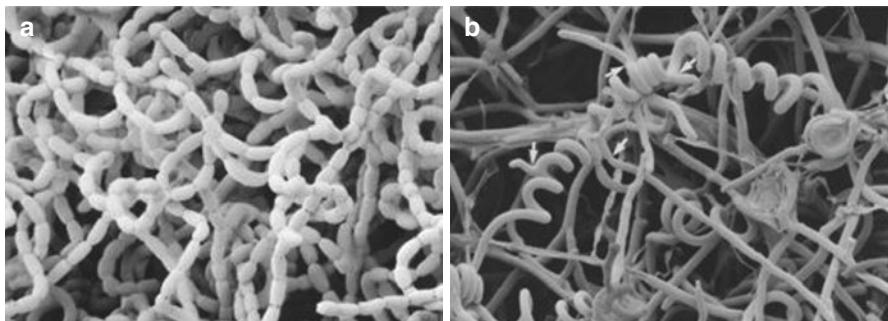
As mentioned, aerial growth involves a complex developmental program whose elements are yet to be discovered.

### 3.2.2 Developmental Regulators

The isolates which are not able to form aerial mycelium are referred to as Bld phenotype, and also the mutant colonies that remained white, i.e., the spore pigments are not produced, are called the Whi phenotype (Hopwood et al. 1970). Apart from a few isolates of Whi phenotype that only failed in pigment synthesis step, in others, cessation of sporulation occurred during different stages (McCormick and Flårdh 2012). Isolation of *whi* mutants led scientists to identify the key sporulation regulators.

*WhiA*, *whiB*, *whiG*, *whiH*, *whiI*, and *whiJ*, known as early *whi* genes, are required for early sporulation stages of aerial hyphae including formation of sporulation septa.

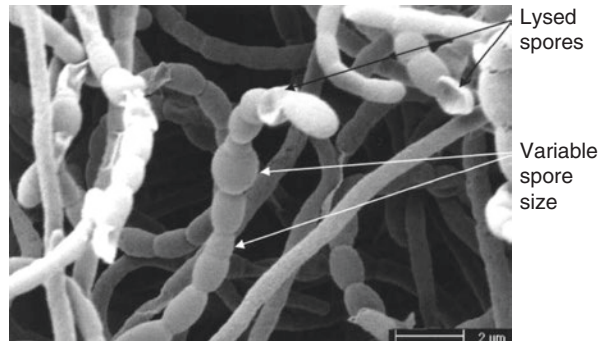
The phenotypes of *whiA* and *whiB* and also double mutants are identical with long and highly coiled hyphae lacking sporulation septa and condensed nuclei (Fig. 3.4), indicating the key role of *whiA* and *whiB* for cessation of further aerial extension (Ainsa et al. 2000; Chater and Chandra 2006). *WhiA* and *whiB* act coordinately through an unknown mechanism which might occur when the proteins reach a critical concentration or as a response to a cellular signal. The cluster harboring *whiA* gene is conserved among Gram-positive bacteria. Also, the presence of *whiA* homologues has been detected in *Fusobacteria* and *Thermotoga*. In contrast, WhiB-like proteins (Wbl), a large family of WhiB homologues, featured by four conserved cysteine residues, have been found only in actinobacteria (Ainsa et al. 2000; McCormick and Flårdh 2012).



**Fig. 3.4** Scanning electron image of *whiA*-deficient mutant of *Streptomyces coelicolor* A3 (2). (a) Chains of uniccular spores in wild-type strain and (b) coiled aerial hypha of mutant strain without sporulation septa (Arrows show a number of branches immersed from the coiled hyphae). (Ainsa et al. 2000)



**Fig. 3.5** Scanning electron image of *whiD*-deficient mutant of *Streptomyces coelicolor* A3 (2) (Molle et al. 2000)



Sequencing *whiD* gene in *Streptomyces coelicolor* A3 (2) revealed that the protein is a homologue of WhiB protein with high amino acid sequence similarity. Also, the four cysteine residues present in WhiB primary sequence have been detected in the case of WhiD. Regarding this perfect conservation, it is suggested that these four residues may act as ligands for a metal cofactor such as zinc, copper, or an iron-sulfur cluster or that they may be involved in intramolecular disulfide bond formation. *whiB*, *whiD* have also been identified only in members of actinobacteria (Molle et al. 2000).

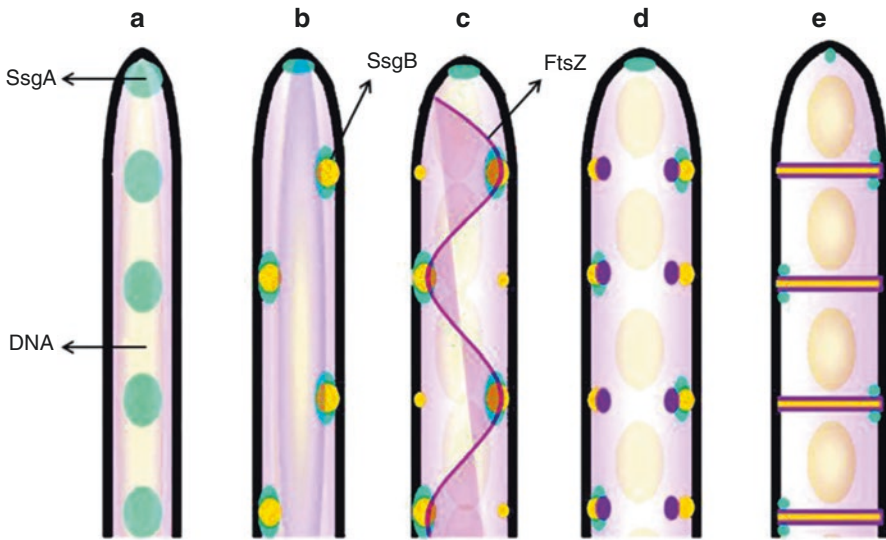
The phenotype of *whiD*-null mutants of *Streptomyces coelicolor* A3 (2) was distinguished from wild type with varied spore size, the emergence of spore lysis, and also irregular partitioning of spore compartment indicating the involvement of WhiD in initiation of sporulation septation (Fig. 3.5) (Molle et al. 2000).

Also, *whiH* and *whiI* are two regulatory genes controlled by RNA polymerase sigma factor  $\sigma^{\text{WhiG}}$  which are required for spore formation at initiation of sporulation. Mutation in *whiG* is epistatic on *whiH* and *whiI*, resulting in blockage of differentiation progression in aerial hyphae (Chater 1975; Flårdh et al. 1999). According to a suggested model, *whiA/whiB* and *whiG/whiH/whiI* are the two parallel but converging pathways required for sporulation (McCormick and Flårdh 2012).

### 3.2.3 Sporulation

#### 3.2.3.1 Sporulation-Specific Cell Division

Cell division as a non-vital process for *Streptomyces* growth occurs during sporulation and is initiated by forming a ladder of Z-rings. In contrast to other bacteria, FtsZ is not the first component of divisome localizing at the division site of *Streptomyces*. In this filamentous bacterium, SsgA first localizes at the future division site where cell wall remodeling occurs and forms foci at the arrival site of SsgB, the protein that recruits FtsZ. SsgB and SsgA are the members of the family of SsgA-like proteins (SALPs), a group of proteins limited to morphologically complex actinomycetes. The non-sporulating phenotypes of the SsgA and SsgB null mutants have occurred exclusively in sporulating actinomycetes. A direct



**Fig. 3.6** Steps of Z-ring formation in *Streptomyces* aerial hyphae. (a) Formation of foci by SsgA, (b) localization of SsgA and SsgB at alternating sides, (c) formation of long spiral-like filaments of FtsZ at alternating sides, (d) strong interaction of SsgA with membrane, and (e) formation of Z-ring (Willemse et al. 2011)

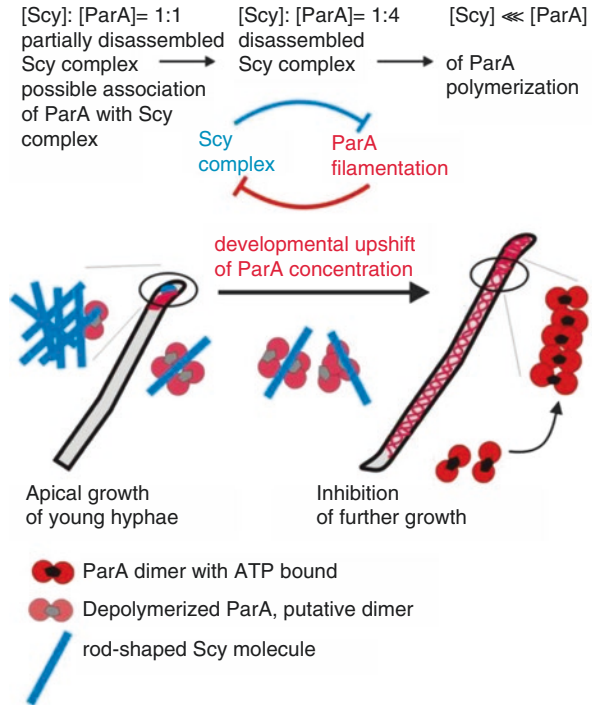
relationship has been suggested between the number of SLAPs and the complexity degree of the actinobacteria morphology (Traag and van Wezel 2008). SsgB activates polymerization of long protofilaments of FtsZ of around 450 nm. Indeed, FtsZ proteins must accumulate to an appropriate level through the function of WhiA as the direct activator of FtsZ expression (Bush et al. 2013; Willemse et al. 2011) (Fig. 3.6).

### 3.2.3.2 Chromosome Segregation

In contrast to vegetative and aerial hypha of *Streptomyces* species in which multiple chromosomes remain unseparated and uncondensed, during sporulation, numerous copies of chromosomes are segregated and condensed in synchronized manner (Jakimowicz and van Wezel 2012). ParAB system is the segregation process responsible system. ParA is an ATPase distributed along the saprogenic aerial hyphae, and ParB is located on the multiple *parS* sites, adjacent to *oriC*, in the form of nucleoprotein complex and traps DNA loops (McCormick and Flärth 2012). ParB is responsible to organize the linear chromosome into nucleoprotein complexes located in regular distance from each other to guarantee the further presence of each genome copy in prespores (Dedrick et al. 2009).

Initiation of sporulation is mediated by ParA-ParJ interaction. ParJ is an actinobacteria-specific protein, required for proper chromosome segregation in sporulating hyphae through involving in stabilizing ParA monomers and inhibition of their polymerization before sporulation septation (Ditkowski et al. 2013).

**Fig. 3.7** Model of ParA-Scy interaction in *Streptomyces*-sporulating hyphae (Donczew et al. 2016)



Also, it has been reported that the interaction of ParA with Scy, a tip-associated protein, plays an important role in controlling *S. coelicolor* tip extension and ParA mutants were elongated. ParA and Scy have negative regulation effect on each other, i.e., Scy inhibits ParA polymerization, and reciprocally, ParA inhibits Scy assembly into higher-order structures (Ditkowski et al. 2013). (Fig. 3.7).

Regarding dynamic polymerization of ParAs and their function, ParAs are considered as the cytoskeleton proteins (Ditkowski et al. 2013).

In the final stage of chromosome segregation, two proteins are involved, Smc and FtsK, a condensation protein and a septum-localized DNA motor protein, respectively. The FtsK homologue in *Bacillus subtilis* is SpoIIIE, a protein that is responsible to chromosome transportation during septum closure. The absence of FtsK in *S. coelicolor* increases DNA instability. SsfA is a member of SpoIIIE/FtsK family that is expressed specifically in sporogenic hyphae and is needed for correct chromosome condensation in coordination with SmeA (Jakimowicz and van Wezel 2012).

### 3.2.3.3 Spore Maturation

MreB and Mb1 are the two actin-like proteins (actin homologues) acting as the first molecules in spore wall maturing stage belonging to the large *Streptomyces* spore wall synthesis complex (SSSC). The other parts of this SSSC are MerC, MerD, Pbp2, and the RodA-FtsW-like protein Sfr. The interaction of the SSSC

proteins with each other and also with the protein responsible for wall teichoic acid, SCO2584, is required for proper spore wall assembly (Heichlinger et al. 2011; Kleinschnitz et al. 2011). Developmental regulation of cell wall assembly stage during sporulation is due to overexpression of *merBCD* and *pbp2-sfr* operon promoter (Burger et al. 2000). Also, developmental regulation of *mbll* strictly occurs at the late sporulation steps. Any mutation in SSSC complex parts results in appearance of thin spore wall with higher stress sensitivity (Heichlinger et al. 2011).

Since *Streptomyces* spore wall is assembled from the inside (in contrast to other bacteria), the presence of the four cell wall hydrolase genes including *rpfa*, *swlA*, *swlB*, and *swlC* which are required for degrading or remodeling the original peptidoglycan layer of the aerial hypha is necessary (Haizer et al. 2009).

Differentiation of *Streptomyces* aerial hyphae into mature spores makes them capable to survive in quiescent state for long periods of time and withstand desiccation and other challenging conditions. In *Bacillus* endospores, small, acid-soluble, DNA-binding proteins (SASPs) and dipicolinic acid (DPA) complexed with  $Ca^{2+}$  are responsible for maintaining the spore DNA integrity. However, SASP and DAP homologues have not been detected in *Streptomyces* spores, yet, but other nucleoid-associated proteins are contributed in protecting nucleic acid structure (McCormick and Flårdh 2012).

### 3.2.3.4 Control of *Streptomyces* Sporulation

The study of SLAP knockout in *S. coelicolor* indicated the role of SLAPs not only in sporulation-specific cell division (SsgA and SsgB) but in the whole sporulation process from initiation of septal peptidoglycan synthesis to the separation of spores from the maturing prespore chain, including proper chromosome condensation (SsgC), spore wall synthesis (SsgD), autolytic spore wall separation

**Table 3.1** The phenotype and time of activity of SLAP mutant during sporulation of *S. coelicolor* (Noens et al. 2005)

Gene	Phenotype of SALP mutants	Timing of activity
<i>ssgA</i>	Conditional non-sporulating phenotype; enhanced expression stimulates sporulation-specific cell division	Septum initiation
<i>ssgB</i>	Strictly non-sporulating phenotype, very large (“immortal”) colonies	Correlates temporally to growth cessation of aerial hyphae before onset of sporulation
<i>ssgC</i>	Irregular spores, imperfect segregation of DNA, very long ladders of spore septa	Controls septum site initiation and DNA segregation
<i>ssgD</i>	Aberrant spore wall	Lateral cell wall synthesis
<i>ssgE</i>	Predominantly single spores due to accelerated autolysis	Correct timing of spore dissociation
<i>ssgF</i>	Short spore chains; old spores were stained with WGA at the outside of the spore poles; rotated spores	Final stages of spore separation
<i>ssgG</i>	Septa are regularly skipped, without affecting DNA segregation. Many spores exactly two, three, or four times the normal size	Controls septum site localization

(SsgE, SsgF), and exact septum localization (SsgG) (Table 3.1) (Noens et al. 2005).

### 3.2.3.5 Spore Germination

Spore germination, as the first step of *Streptomyces* development, comprises a sequence of three stages including darkening, swelling, and germ tube emergence. Divalent cations of calcium, magnesium, and iron and also the spore energy reserves are needed for darkening step. Calcium accumulates in the spore covers and released during sporulation. In contrast to darkening, swelling needs exogenous carbon source. For germ tube emergence, additional nitrogen and carbon source is required. Like spore formation, cell wall hydrolases play an important role at the germination step (Yagüe et al. 2013).

### 3.2.3.6 *Streptomyces* Programmed Cell Death

Programmed cell death (PCD) is defined as an active cellular suicide which is shown to occur in eukaryotes as well as in many bacteria in response to both abiotic and biotic stresses. In prokaryotes, PCD is believed either to occur during the developmental life cycle of certain bacteria or to remove damaged cells from a population in response to a wide variety of stresses. Although programmed cell death occurs both in eukaryotic and prokaryotic cells, little is known about the regulation mechanism of bacterial suicide process at the molecular level, in contrast to eukaryotic apoptosis. A proteomic analysis revealed that PCD in *S. coelicolor* was accompanied by the involvement of several enzymes functioning in degradation of cellular macromolecules, regulatory proteins, and stress-induced proteins. Oxidative stress has been suggested as the cause or result of PCD due to antioxidant increased levels, associated with PCD. Further investigations are needed to identify PCD-regulating pathways and its position in *Streptomyces* biology (Manteca and Sanchez 2010).

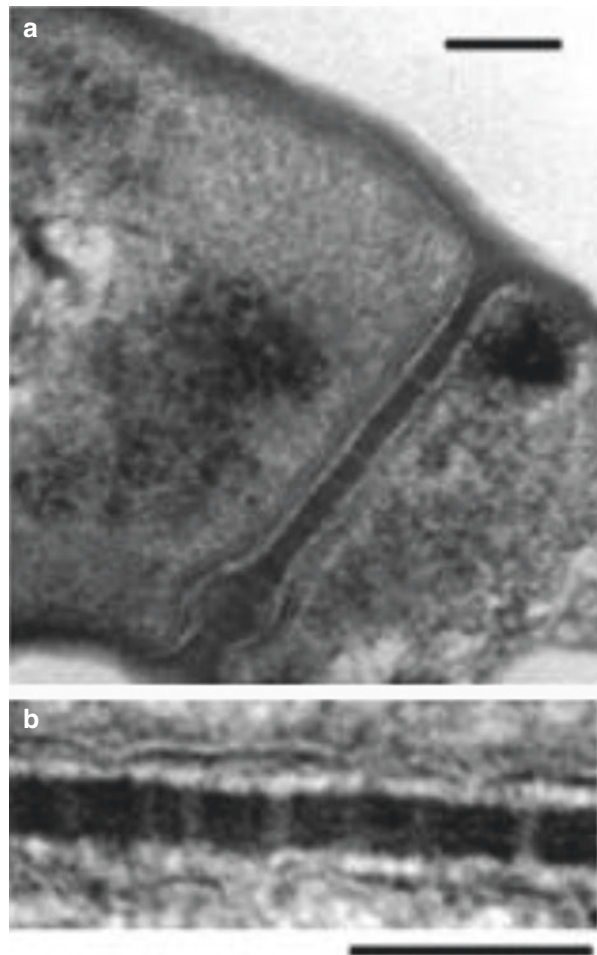
## 3.2.4 Cell Division

Bacterial cell division is mostly governed by the tubulin-like protein FtsZ with GTPase activity which polymerizes and assembles the Z-ring in the mid-cell. The so-called Z-ring then recruits other proteins needed for cell division and cell wall synthesis which will then comprise an ultrastructure called divisome.<sup>1</sup> A complex regulatory mechanism with several proteins controls the spatiotemporal occurrence of cell division. Although basics of cell division are common among most *Eubacteria*, this spatiotemporal regulation greatly differs in actinobacteria. This means that no homologues for the positive and negative regulators of cell division in other bacteria such as the best-studied *E. coli* or *B. subtilis* are found in actinobacteria. These bacteria implement a different and specific set of proteins (FtsQ, FtsL, DivIC, FtsW, and FtsI) for this purpose which show differences in their functions (Errington et al. 2003).

---

<sup>1</sup>A dynamic multiprotein assembly localizing at mid-cell to synthesize the stress-bearing peptidoglycan and to constrict all cell envelope layers

Due to the unique life cycle of actinomycetes, cell division in these bacteria is thought to occur in two ways: vegetative septation leading to cross walls in the substrate mycelium and developmentally regulated sporulation/reproductive septation. It is important to note that for both types of cell division, one gene for FtsZ exists, and the mutants of this gene showed blocked cell division for both types (McCormick 2009). Moreover, nonfilamentous actinobacteria also show some differences in their cell division procedure in comparison to other orders of bacteria which is being discussed in this section. It is important to note that since cell division is reported to be not essential for growth of the hyphae in streptomycetes, they are favorable candidates for the study of cell division mechanisms (McCormick 2009). Therefore, most of the findings regarding cell division in actinomycetes are gained through experimentations on these organisms.



**Fig. 3.8** (a) Transmission electron microscopy of cross walls in vegetative mycelium of *S. coelicolor*. (b) The vegetative septum channels (bars 100 nm) (Adopted from Jakimowicz and van Wezel 2012)

### 3.2.5 Vegetative Septation

During the growth in vegetative mycelium, there are cross walls infrequently formed at irregular intervals which are also not always uniform in width and appearance. These cross walls do not cause the subsequent separation of the hyphal compartments; however, high-resolution imaging experiments revealed that there are channels which allow the transport of components over the membrane (Fig. 3.8). Therefore, a connected multicellular network along the actinobacterial hypha is produced (Jakimowicz and van Wezel 2012). These cross walls are also occasionally found in aerial hyphae but yet different to that of sporulation septa (Flårdh and Buttner 2009).

In general, the sporulation mechanism of actinomycetes, especially the model actinobacteria *S. coelicolor*, is better studied than its vegetative cell division process; thus less information is available. A time-lapse microscopy study in *S. coelicolor* by Jyothikumar et al. revealed some more information about the vegetative cell division. Accordingly, it was reported that the frequency of vegetative septa formation can vary between species of actinomycetes, and the culture conditions can affect this frequency. They have revealed for the first time that despite the previous thought that the daughter compartment of vegetative mycelium creates a new extension site by branching and subsequently this emerging extension will be partitioned through a novel septum, branching occurs before rings of FtsZ-EGFP and septa are formed (Jyothikumar et al. 2008).

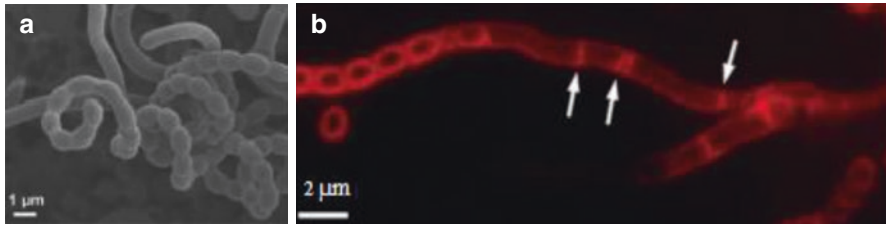
Conclusively, both growth and branching of vegetative mycelium hyphae take place prior to the formation of FtsZ-EGFP rings. Thus, FtsZ is believed to be essential in marking sites for septation in *S. coelicolor*. Jyothikumar et al. suggested that the major role of septum formation in vegetative mycelium is to prevent cytoplasmic leakage in the event of a breach of the hyphal walls following a trauma such as phage lysis (Jyothikumar et al. 2008).

#### 3.2.5.1 Reproductive Septation

Once aerial hypha is formed as previously discussed, tens of spores are formed by the synchronous formation of sporulation septa. In contrast to vegetative septa, they are all positioned at exactly the same distance and uniformly produced in a way that there is normally one septum between each chromosome (Fig. 3.9). The sporulation septation will also result in the complete physical separation of new compartments (spores) which will be further released in the environment. Here, the aerial hyphae are divided into several rounded spores with regular size. These septa are also thicker than cross walls.

This is performed by the assembly of FtsZ into regularly spaced, ladder-like structures in the aerial hyphae. The average spacing in *S. coelicolor* is reported to be about 1.3  $\mu\text{m}$  (Schwedock et al. 1997). Each sporulation septum is formed as a double annulus growing toward the center of the hypha although the wall of the parent hypha does not contribute to the formation of the spore wall (Wildermuth and Hopwood 1970).

Obviously the massive assembly of ladder-like ultrastructure of FtsZ requires a cell-specific upregulation of FtsZ transcription (Kwak et al. 2001) together with the exact control of septum location and time. This developmental control involves



**Fig. 3.9** (a) Spore chain produced on aerial hyphae, (b) fluorescent microscopy of sporogenic aerial hyphae (vegetative septa are visible in the non-sporulating part of the aerial hypha) (From Jakimowicz and van Wezel 2012)

**Table 3.2** Important genes involved in sporulation control in *S. coelicolor*

Gene	Function	Reference
<i>whiG</i>	An RNA polymerase sigma factor; key regulator of the commitment of aerial hyphae to sporulation	Mendez and Chater (1987)
<i>whiH</i>	A member of the GntR family of repressors; required for the orderly sporulation septation	Flårdh and Buttner (2009)
<i>whiA</i>	A <i>whiG</i> -independent converging pathway that controls sporulation in aerial hyphae	Flårdh and Buttner (2009)
<i>whiI</i>	A response regulator; autoregulator	Flårdh and Buttner (2009)
<i>whiB</i> and <i>whiD</i>	Transcription factors or might be disulfide reductases	Flårdh and Buttner (2009)
<i>sigF</i>	Affects prespore maturation	Flårdh and Buttner (2009)
<i>whiE</i>	Specifies the synthesis of the gray polyketide spore pigment	Flårdh and Buttner (2009)
<i>ssgA</i> and the SALP genes	Inhibits branching and induces sporulation	Flårdh and Buttner (2009)
<i>sepG</i>	Coordinates sporulation-specific cell division and nucleoid organization	Zhang et al. (2016)
<i>samR</i>	Essential gene for the environmental response	Tan et al. (2002)
<i>ssgR</i>	Positively regulates <i>ssgA</i>	Kim et al. (2015)
<i>atrA</i>	Direct control of <i>ssgR</i>	Kim et al. (2015)
<i>mreB</i>	Influences the assembly of the spore cell wall	Mazza et al. (2006)

many regulatory proteins, many of which are specific to the actinobacterium being studied which are summarized in Table 3.2.

In sum, the localization of sporulation septum is determined by the positive control of SsgB which recruits FtsZ. Prior to this phenomenon, SsgB interacts briefly with SsgA and becomes activated. It is noteworthy to mention that the highly symmetrical spacing of sporulation septa (or the localization of SsgB itself) is recently predicted to be governed by the function of SepG which plays an important role in



the stable localization of SsgB to future septum sites and contributes to the maintenance of chromosome compaction (Zhang et al. 2016).

A third type of septum called basal septum is reported. This kind of septa has been observed at the base of sporogenic hyphae in submerged cultures of *S. griseus* and is shown to play roles in delimiting a part of the hyphae allowing increased expression of *ftsZ* and thus acts as a sporulation septation inducer (Jakimowicz and van Wezel 2012). Other roles for this kind of septum (here called “subapical stem”) are also reported by Dalton et al. which denotes that they can be found at the base of nascent aerial hyphae and helps to proceed the compartment-specific gene expression (Dalton et al. 2007).

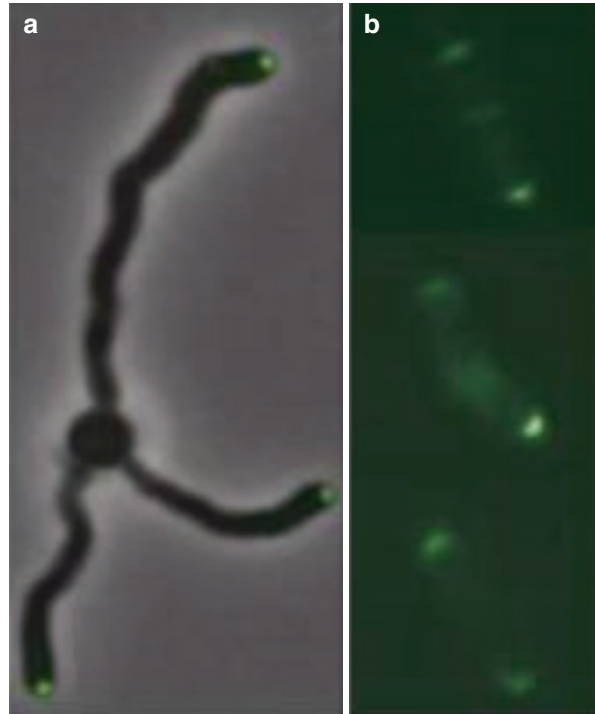
### 3.2.5.2 Cell Division in Nonfilamentous Actinobacteria

Although the core divisome components in cell division are similar to actinomycetes, there are some detail differences observed in rod-shaped actinobacteria. In this regard, unlike the filamentous nature of *Streptomyces*, *Corynebacteriaceae* such as *Mycobacterium* and some other mycolate-producing actinobacteria (*Corynebacterium*, *Gordonia*, *Nocardia*, and *Rhodococcus*) are shown to generally possess a rod-shaped morphology. Therefore, although all these bacteria fall in actinobacterial taxon, due to this difference, *Corynebacteriaceae* display small differences in their developmental stages as being described.

As an important difference in the cell division procedure of *Corynebacteriaceae* with *Streptomyces* sp., the bipolarity of the growth in these bacteria can be named, while *Streptomyces* possess a multipolar growth along the mycelium (Singh et al. 2013).

On the other hand, the apical growth mode present in *Corynebacteriaceae* is suggested to benefit these bacteria in a way that it allows a better-coordinated assembly of the complex cell envelope layers. As in *Streptomyces*, *Mycobacteria* and *Corynebacteria* also implement a DivIVA homologue (Wag31 Kang et al. 2008) for their apical growth which is a tropomyosin-like coiled-coil protein that forms oligomers at the growth tips. However, apparently the DivIVA homologues in *Mycobacterium* and *Corynebacterium* assemble in the two cell poles (Fig. 3.10). By studying different microorganisms possessing DivIVA, it is suggested that there are conserved localization signals for this protein which similarly exist in the division site of the owner cells with different taxonomies. Of these signals is the negative curvature of cell poles which attracts the recruitment of DivIVA for further initiating the cell division (or cell elongation in *Streptomyces*) (Halbedel et al. 2009). However, the function of this protein in facilitating cell division whether in the mid-cell or the poles is determined by phosphorylation. In *Mycobacteria*, the procedure is regulated by PknA and PknB which are serine/threonine protein kinases and phosphorylate the DivIVA protein to further activate it. The phosphorylation site of DivIVA is not conserved in *Streptomyces*; thus, it is possible that the two kinases may not be present in these bacteria, although a homologue for PknB has been reported in *B. subtilis* which was essential in directing spore germination upon recognition of peptidoglycan

**Fig. 3.10** Multipolar versus bipolar apical growth of *Streptomyces* (a) and *Mycobacterium* (b); (Green: green fluorescent protein (GFP)-fused DivIVA) (Adopted from Wang et al. 2009)



fragments released by other bacteria growing in close vicinity (Kang et al. 2005). Conclusively, other than its role in cell division, DivIVA must be studied to see if it plays any role in exiting of *Mycobacterium* and/or *Streptomyces* from dormancy (Scherr and Nguyen 2009).

*Mycobacteria* and *Corynebacteria* can form rod-shaped cells in the absence of the helical MreB homologues. This cytoskeleton protein aids growth by facilitating the formation of newly synthesized peptidoglycan along it. However, *Corynebacterium* and *Mycobacterium* lacking this protein are shown to display a more flexible mode of apical growth in which peptidoglycan precursors are added exclusively at cell poles mainly by the help of DivIVA, RodA, and penicillin-binding protein 1a (PBP1a) and PBP1b (Donovan and Bramkamp 2014).

As shown in Fig. 3.10b, *Mycobacteria* (also true for *Corynebacteria*) are known to form a V shape during the late stages of cell division called “snapping” cell division. This unusual morphology during cell separation is because while the plasma membrane and peptidoglycan form the septa during Z-ring constriction, the thick layers of cell envelope lipids remain intact. Therefore, when the cell divides by hydrolyzing the peptidoglycan linking the daughter cells together, the outer layers are still intertwined. Subsequently, this V-shaped splitting of cells is caused by an uneven snapping of these outer layers (Hett and Rubin 2008).

Moreover, although mostly all rod-shaped bacteria produce two daughter cells with identical sizes, in rod-shaped actinobacteria such as *Mycobacteria*, polar

growth results in daughter cells of different sizes through a process which is called asymmetric cell division. The exact mechanism through which this asymmetric division occurs is still unknown. However, there are two models proposed in this regard. In one model, it is believed that growth at both cell poles is symmetric until cytokinesis.<sup>2</sup> Further, growth becomes faster at the old pole (maternal pole) until the cells separate completely to form unequally sized cells (Santi et al. 2013). In contrast, in the other model, the two cell poles elongate at different rates throughout the whole cell cycle in a manner that the old pole elongates at faster rates (Joyce et al. 2012). Whether first or second model is likely to be the true mechanism, it is believed that asymmetric cell division in *Mycobacteria* causes a heterogeneity in terms of cell size which helps this pathogen to be able to actively grow in the range of host microenvironments (Kieser and Rubin 2014). Studying the tolerance to antibiotics in this heterogenic population is also of great interest.

As another difference in the cell division of rod-shaped actinobacteria, White et al. have reported that the *M. tuberculosis* FtsZ protein possesses a 20-fold slower GTP-dependent polymerization and a weaker GTPase activity in comparison with other bacteria (White et al. 2000). Further, the reason was suggested to be due to the residues of its C-terminus which may inhibit polymerization, imposing a lower rate, while the N-terminus is shown to be conserved and is involved in FtsZ-FtsZ interaction (Hett and Rubin 2008). Although the evolutionary benefit or the advantage of this system to the cell is still unexplored, these findings especially in pathogens such as *Mycobacteria* can greatly help the drug target identification and treatment procedures of the diseases caused by these organisms.

In conclusion, rod-shaped actinobacteria undergo the same general procedure of cell division that other bacteria follow; however, there are differences in terms of the type and function of proteins regulating the cell division as described. It is important to note that many of these differences are yet unexplored and understanding such fundamental procedures may help us understand more complex processes such as pathogenesis and virulence and the physiological information required for biotechnological approaches.

---

### 3.3 Factors Affecting Growth and Differentiation in Actinobacteria

There are many environmental variables having pronounced effects on growth and differentiation of actinomycetes. Among the effects of culture components, there are examples such as the inhibition of septation in *Nocardiaceae* by the limitation of manganese as well as the key effect of gas and temperature in determining mycelioid or diphtheroid growth in *Actinomyces* sp. and *Arthrobacter* sp., respectively. Carbon source also can temporarily affect mycelium growth by reducing the rate of

---

<sup>2</sup>The process in which a plasma membrane forms in the mid-cell region of a mother cell during cell division

mycelium formation. For instance, in some streptomycetes septate, nocardioforms were formed instead of mycelia on synthetic media with fructose. There are also factors stimulating mycelium formation and cell septation such as decreased temperature of incubation, decreased relative humidity (surface cultures), and the addition of Tween 80 in *Nocardia* sp. In these bacteria, carbon sources such as starch, glycogen, and more specifically glucose have led to extension of mycelium and cease in fragmentation (Kalakoutsii and Agre 1976).

Unlike the previously accepted issue that there is a possible relationship of the growth rate and morphogenesis in some actinomycetes such as *Nocardia* sp., studies on the kinetics of hyphal growth and branching in *Streptomyces* sp. showed no relationship between growth rate increases and branch numbers (Miguélez et al. 1992).

The effects of nutrients on sporulation of ten *Streptomyces* have been also studied, and results showed that media containing mineral sources of nitrogen act better than organic nitrogen sources. However, as a more general result, it is better to conclude from different studies that nutrients have rather variable effects on sporulation of *Streptomyces* spp. as the difference in concentration of carbon, nitrogen, or phosphorus sources causes differences in their ratios and subsequently may form growth-restricting conditions (Kontroab et al. 2007). Moreover, it was also reported that the sporulation in the submerged culture of several *Streptomyces* spp. is better triggered when some nutrients especially phosphorus are exhausted. Daza et al. have also suggested that the ratio between  $\text{Ca}^{2+}$  and phosphate or nucleotides is critical in inducing sporulation in submerged cultures. They have reported that the effect may be caused by the reduction of GTP by high concentrations of  $\text{Ca}^{2+}$  and thus activation of stringent response which is correlated with differentiation and sporulation in *Streptomyces* sp. (Daza et al. 1989). Amino acids like methionine and tryptophan (Palazzotto et al. 2015), humic and fulvic acids, biotin, and also complex organic media are also factors reported to be favorable for sporulation (Kontro et al. 2005).

Other than nutrient requirements, pH values might be critical for sporulation and hyphal formation in actinomycetes, since slightly alkaline pH ranges favor spore formation (Kontro et al. 2005). Regarding aerial hyphae formation and growth, narrow temperature optima are reported in comparison to vegetative growth. However, exact information on suppressive effects of environmental factors on aerial hypha information is still lacking and needs additional attention.

Conclusively, there is an extreme flexibility and plasticity regarding actinobacterial growth and differentiation in response to different environmental factors. The comprehensive study of these factors not only can give useful information for their physiology but also can be extremely beneficial to be used in fermentation technology as many of these bacteria are industrially important strains used for the production of many secondary metabolites such as antibiotics.

## Conclusions

There have been much effort to unravel the physiology of bacterial growth and cell division within actinobacteria. Since this taxon comprises both pathologically important (e.g., *Mycobacterium tuberculosis* and *Corynebacterium diphtheria*) and biotechnologically relevant strains (e.g., *Corynebacterium glutamicum* and *Streptomyces griseus*), exact information on their growth and cell division dynamics is essential in designing treatment or production enhancement strategies. Regarding the importance of growth studies, the somehow-recent observation that actinobacterial spores can produce secondary metabolites such as antibiotics or the possibility of spore formation in liquid cultures can greatly help in biotechnological productions. However, most of the aforementioned studies in actinobacteria have been performed on a few model organisms such as *S. coelicolor* and few members of *Mycobacteriaceae* and *Corynebacteriaceae*. Therefore, to confidently claim that all aspects of actinobacterial growth and differentiation together with their molecular basis and dynamics are unraveled, there are much work yet to be performed such as producing useful microscopy images, related gene functional annotations, and experimental validations as well as performing comparative studies to present accurate actinobacterial growth and cell division models.

## References

- Ainsa J, Ryding N, Hartley N, Findlay K, Bruton C, Chater K (2000) WhiA, a protein of unknown function conserved among gram-positive bacteria, is essential for sporulation in *Streptomyces coelicolor* A3 (2). *J Bacteriol* 182(19):5470–5478
- Alonso A, Pomposiello P, Leschine S (2008) Biofilm formation in the life cycle of the cellulolytic actinomycete *Thermobifida fusca*. *Biofilms* 2008:1–11
- Barka EA, Vatsa P, Sanchez L, Gaveau-Vaillant N, Jacquard N, Klenk H-P et al (2016) Taxonomy, physiology, and natural products of Actinobacteria. *Microbiol Mol Biol Rev* 80(1):1–43
- Burger A, Sichler K, Kelemen G, Buttner M, Wohlleben W (2000) Identification and characterization of the mre gene region of *Streptomyces coelicolor* A3 (2). *Mol Gen Genet MGG* 263(6):1053–1060
- Bush MJ, Bibb MJ, Chandra G, Findlay KC, Buttner MJ (2013) Genes required for aerial growth, cell division, and chromosome segregation are targets of WhiA before sporulation in *Streptomyces venezuelae*. *MBio* 4(5):e00684–e006613
- Capstick DS, Willey JM, Buttner MJ, Elliot MA (2007) SapB and the chaplins: connections between morphogenetic proteins in *Streptomyces coelicolor*. *Mol Microbiol* 64(3):602–613
- Chater K (1975) Construction and phenotypes of double sporulation deficient mutants in *Streptomyces coelicolor* A3 (2). *Microbiology* 87(2):312–325
- Chater KF, Chandra G (2006) The evolution of development in *Streptomyces* analysed by genome comparisons. *FEMS Microbiol Rev* 30(5):651–672
- Claessen D, Rink R, de Jong W, Siebring J, de Vreugd P, Boersma FH et al (2003) A novel class of secreted hydrophobic proteins is involved in aerial hyphae formation in *Streptomyces coelicolor* by forming amyloid-like fibrils. *Genes Dev* 17(14):1714–1726

- Claessen D, Stokroos I, Deelstra HJ, Penninga NA, Bormann C, Salas JA et al (2004) The formation of the rodlet layer of streptomycetes is the result of the interplay between rodlines and chaplins. *Mol Microbiol* 53(2):433–443
- D'Alia D, Eggle D, Nieselt K, Hu WS, Breitling R, Takano E (2011) Deletion of the signalling molecule synthase ScbA has pleiotropic effects on secondary metabolite biosynthesis, morphological differentiation and primary metabolism in *Streptomyces coelicolor* A3 (2). *Microb Biotechnol* 4(2):239–251
- Dalton KA, Thibessard A, Hunter JI, Kelemen GH (2007) A novel compartment, the 'subapical stem' of the aerial hyphae, is the location of a sigN-dependent, developmentally distinct transcription in *Streptomyces coelicolor*. *Mol Microbiol* 64(3):719–737
- Daza A, Martin JF, Dominguez A, Gil JA (1989) Sporulation of several species of *Streptomyces* in submerged cultures after nutritional downshift. *Microbiology* 135(9):2483–2491
- Dedrick RM, Wildschutte H, McCormick JR (2009) Genetic interactions of smc, ftsK, and parB genes in *Streptomyces coelicolor* and their developmental genome segregation phenotypes. *J Bacteriol* 191(1):320–332
- Di Berardo C, Capstick DS, Bibb MJ, Findlay KC, Buttner MJ, Elliot MA (2008) Function and redundancy of the chaplin cell surface proteins in aerial hypha formation, rodlet assembly, and viability in *Streptomyces coelicolor*. *J Bacteriol* 190(17):5879–5889
- Ditkowski B, Holmes N, Rydzak J, Donczew M, Bezulska M, Ginda K et al (2013) Dynamic interplay of ParA with the polarity protein, Scy, coordinates the growth with chromosome segregation in *Streptomyces coelicolor*. *Open biology* 3(3):130006
- Donczew M, Mackiewicz P, Wróbel A, Flårdh K, Zakrzewska-Czerwińska J, Jakimowicz D (2016) ParA and ParB coordinate chromosome segregation with cell elongation and division during *Streptomyces* sporulation. *Open biology* 6(4):150263
- Donovan C, Bramkamp M (2014) Cell division in Corynebacterineae. *Front Microbiol* 5:132
- Ekkers DM, Claessen D, Galli F, Stamhuis E (2014) Surface modification using interfacial assembly of the *Streptomyces* chaplin proteins. *Appl Microbiol Biotechnol* 98(10):4491–4501
- Elliot MA, Karoonuthaisiri N, Huang J, Bibb MJ, Cohen SN, Kao CM, Buttner MJ (2003) The chaplins: a family of hydrophobic cell-surface proteins involved in aerial mycelium formation in *Streptomyces coelicolor*. *Genes Dev* 17(14):1727–1740
- Errington J, Daniel RA, Scheffers D-J (2003) Cytokinesis in bacteria. *Microbiol Mol Biol Rev* 67(1):52–65
- Flårdh K, Buttner MJ (2009) *Streptomyces* morphogenetics: dissecting differentiation in a filamentous bacterium. *Nat Rev Microbiol* 7(1):36–49
- Flårdh K, Findlay KC, Chater KF (1999) Association of early sporulation genes with suggested developmental decision points in *Streptomyces coelicolor* A3 (2). *Microbiology* 145(9):2229–2243
- Flårdh K, Richards DM, Hempel AM, Howard M, Buttner MJ (2012) Regulation of apical growth and hyphal branching in *Streptomyces*. *Curr Opin Microbiol* 15(6):737–743
- Fuhrmann C, Soedarmanto I, Lämmle C (1997) Studies on the Rod-Coccus life cycle of *Rhodococcus equi*. *J Veterinary Med Ser B* 44(1–10):287–294
- Glazebrook MA, Doull JL, Stuttard C, Vining LC (1990) Sporulation of *Streptomyces venezuelae* in submerged cultures. *Microbiology* 136(3):581–588
- Goodfellow M, Alderson G, Chun J (1998) Rhodococcal systematics: problems and developments. *Antonie Van Leeuwenhoek* 74(1–3):3–20
- Gray D, Gooday G, Prosser J (1990) Apical hyphal extension in *Streptomyces coelicolor* A3 (2). *Microbiology* 136(6):1077–1084
- Haiser HJ, Yousef MR, Elliot MA (2009) Cell wall hydrolases affect germination, vegetative growth, and sporulation in *Streptomyces coelicolor*. *J Bacteriol* 191(21):6501–6512
- Halbedel S, Visser L, Shaw M, Wu LJ, Errington J, Marenduzzo D, Hamoen LW (2009) Localisation of DivIVA by targeting to negatively curved membranes. *EMBO J* 28(15):2272–2282
- Heichlinger A, Ammelburg M, Kleinschnitz E-M, Latus A, Maldener I, Flårdh K et al (2011) The MreB-like protein Mbl of *Streptomyces coelicolor* A3 (2) depends on MreB for proper localization and contributes to spore wall synthesis. *J Bacteriol* 193(7):1533–1542

- Hett EC, Rubin EJ (2008) Bacterial growth and cell division: a mycobacterial perspective. *Microbiol Mol Biol Rev* 72(1):126–156
- Hopwood DA, Wildermuth H, Palmer HM (1970) Mutants of *Streptomyces coelicolor* defective in sporulation. *Microbiology* 61(3):397–408
- Jakimowicz D, van Wezel GP (2012) Cell division and DNA segregation in *Streptomyces*: how to build a septum in the middle of nowhere? *Mol Microbiol* 85(3):393–404
- Joyce G, Williams KJ, Robb M, Noens E, Tizzano B, Shahrezaei V, Robertson BD (2012) Cell division site placement and asymmetric growth in mycobacteria. *PLoS One* 7(9):e44582
- Jyothikumar V, Tilley EJ, Wali R, Herron PR (2008) Time-lapse microscopy of *Streptomyces coelicolor* growth and sporulation. *Appl Environ Microbiol* 74(21):6774–6781
- Kalakoutskii L, Agre NS (1976) Comparative aspects of development and differentiation in actinomycetes. *Bacteriol Rev* 40(2):469
- Kang C-M, Abbott DW, Park ST, Dascher CC, Cantley LC, Husson RN (2005) The Mycobacterium tuberculosis serine/threonine kinases PknA and PknB: substrate identification and regulation of cell shape. *Genes Dev* 19(14):1692–1704
- Kang C-M, Nyayapathy S, Lee J-Y, Suh J-W, Husson RN (2008) Wag31, a homologue of the cell division protein DivIVA, regulates growth, morphology and polar cell wall synthesis in mycobacteria. *Microbiology* 154(3):725–735
- Kaval KG, Halbedel S (2012) Architecturally the same, but playing a different game: the diverse species-specific roles of DivIVA proteins. *Virulence* 3(4):406–407
- Kieser KJ, Rubin EJ (2014) How sisters grow apart: mycobacterial growth and division. *Nat Rev Microbiol* 12(8):550–562
- Kim SH, Traag BA, Hasan AH, McDowall KJ, Kim B-G, van Wezel GP (2015) Transcriptional analysis of the cell division-related *ssg* genes in *Streptomyces coelicolor* reveals direct control of *ssgR* by AtrA. *Antonie Van Leeuwenhoek* 108(1):201–213
- Kleinschnitz EM, Heichlinger A, Schirmer K, Winkler J, Latus A, Maldener I et al (2011) Proteins encoded by the MRE gene cluster in *Streptomyces coelicolor* A3 (2) cooperate in spore wall synthesis. *Mol Microbiol* 79(5):1367–1379
- Kontro M, Lignell U, Hirvonen MR, Nevalainen A (2005) pH effects on 10 *Streptomyces* spp. growth and sporulation depend on nutrients. *Lett Appl Microbiol* 41(1):32–38
- Kontroab M, Lignella U, Hyvärinen A, Vahteristö M, Hirvonen M, Nevalainen A (2007) Nutrient effects on ten *Streptomyces* spp. sporulation, in *Communicating Current Research and Educational Topics and Trends in Applied Microbiology*. Formatex 137–142
- Kwak J, Dharmatilake AJ, Jiang H, Kendrick KE (2001) Differential regulation of *ftsZ* transcription during septation of *Streptomyces griseus*. *J Bacteriol* 183(17):5092–5101
- Manteca A, Sanchez J (2010) *Streptomyces* developmental cycle and secondary metabolite production. *Curr Res Technol Educ Top Appl Microbiol Microb Biotechnol* 1:560–566
- Mazza P, Noens EE, Schirmer K, Grantcharova N, Mommaas AM, Koerten HK et al (2006) MreB of *Streptomyces coelicolor* is not essential for vegetative growth but is required for the integrity of aerial hyphae and spores. *Mol Microbiol* 60(4):838–852
- McCormick JR (2009) Cell division is dispensable but not irrelevant in *Streptomyces*. *Curr Opin Microbiol* 12(6):689–698
- McCormick JR, Flärth K (2012) Signals and regulators that govern *Streptomyces* development. *FEMS Microbiol Rev* 36(1):206–231
- Mendez C, Chater KF (1987) Cloning of *whiG*, a gene critical for sporulation of *Streptomyces coelicolor* A3 (2). *J Bacteriol* 169(12):5715–5720
- Miguélez EM, Martín C, Manzanal MB, Hardisson C (1992) Growth and morphogenesis in *Streptomyces*. *FEMS Microbiol Lett* 100(1–3):351–359
- Molle V, Palframan WJ, Findlay KC, Buttner MJ (2000) *WhiD* and *WhiB*, homologous proteins required for different stages of sporulation in *Streptomyces coelicolor* A3 (2). *J Bacteriol* 182(5):1286–1295
- Noens EE, Mersinias V, Traag BA, Smith CP, Koerten HK, van Wezel GP (2005) SsgA-like proteins determine the fate of peptidoglycan during sporulation of *Streptomyces coelicolor*. *Mol Microbiol* 58(4):929–944

- Palazzotto E, Renzone G, Fontana P, Botta L, Scaloni A, Puglia AM, Gallo G (2015) Tryptophan promotes morphological and physiological differentiation in *Streptomyces coelicolor*. *Appl Microbiol Biotechnol* 99(23):10177–10189
- Pérez J, Muñoz-Dorado J, Braña AF, Shimkets LJ, Sevillano L, Santamaría RI (2011) *Myxococcus xanthus* induces actinorhodin overproduction and aerial mycelium formation by *Streptomyces coelicolor*. *Microb Biotechnol* 4(2):175–183
- Santi I, Dhar N, Bousbaine D, Wakamoto Y, McKinney JD (2013) Single-cell dynamics of the chromosome replication and cell division cycles in mycobacteria. *Nat Commun* 4:2470
- Scherr N, Nguyen L (2009) Mycobacterium versus Streptomyces—we are different, we are the same. *Curr Opin Microbiol* 12(6):699–707
- Schwedock J, McCormick J, Angert E, Nodwell J, Losick R (1997) Assembly of the cell division protein FtsZ into ladder-like structures in the aerial hyphae of *Streptomyces coelicolor*. *Mol Microbiol* 25(5):847–858
- Singh B, Nitharwal RG, Ramesh M, Pettersson B, Kirsebom LA, Dasgupta S (2013) Asymmetric growth and division in Mycobacterium spp.: compensatory mechanisms for non-medial septa. *Mol Microbiol* 88(1):64–76
- Tan H, Tian Y, Yang H, Liu G, Nie L (2002) A novel Streptomyces gene, samR, with different effects on differentiation of Streptomyces ansochromogenes and *Streptomyces coelicolor*. *Arch Microbiol* 177(3):274–278
- Traag BA, van Wezel GP (2008) The SsgA-like proteins in actinomycetes: small proteins up to a big task. *Antonie Van Leeuwenhoek* 94(1):85–97
- Wang S-B, Cantlay S, Nordberg N, Letek M, Gil JA, Flärdh K (2009) Domains involved in the in vivo function and oligomerization of apical growth determinant DivIVA in *Streptomyces coelicolor*. *FEMS Microbiol Lett* 297(1):101–109
- White EL, Ross LJ, Reynolds RC, Seitz LE, Moore GD, Borhani DW (2000) Slow polymerization of Mycobacterium tuberculosis FtsZ. *J Bacteriol* 182(14):4028–4034
- Wildermuth H, Hopwood D (1970) Septation during sporulation in *Streptomyces coelicolor*. *Microbiology* 60(1):51–59
- Willemsse J, Borst JW, de Waal E, Bisseling T, van Wezel GP (2011) Positive control of cell division: FtsZ is recruited by SsgB during sporulation of Streptomyces. *Genes Dev* 25(1):89–99
- Yagüe P, López-García MT, Rioseras B, Sánchez J, Manteca Á (2013) Pre-sporulation stages of Streptomyces differentiation: state-of-the-art and future perspectives. *FEMS Microbiol Lett* 342(2):79–88
- Zhang L, Willemsse J, Claessen D, van Wezel GP (2016) SepG coordinates sporulation-specific cell division and nucleoid organization in *Streptomyces coelicolor*. *Open biology* 6(4):150164



Fatemeh Mohammadipannah and Mona Dehghaghi

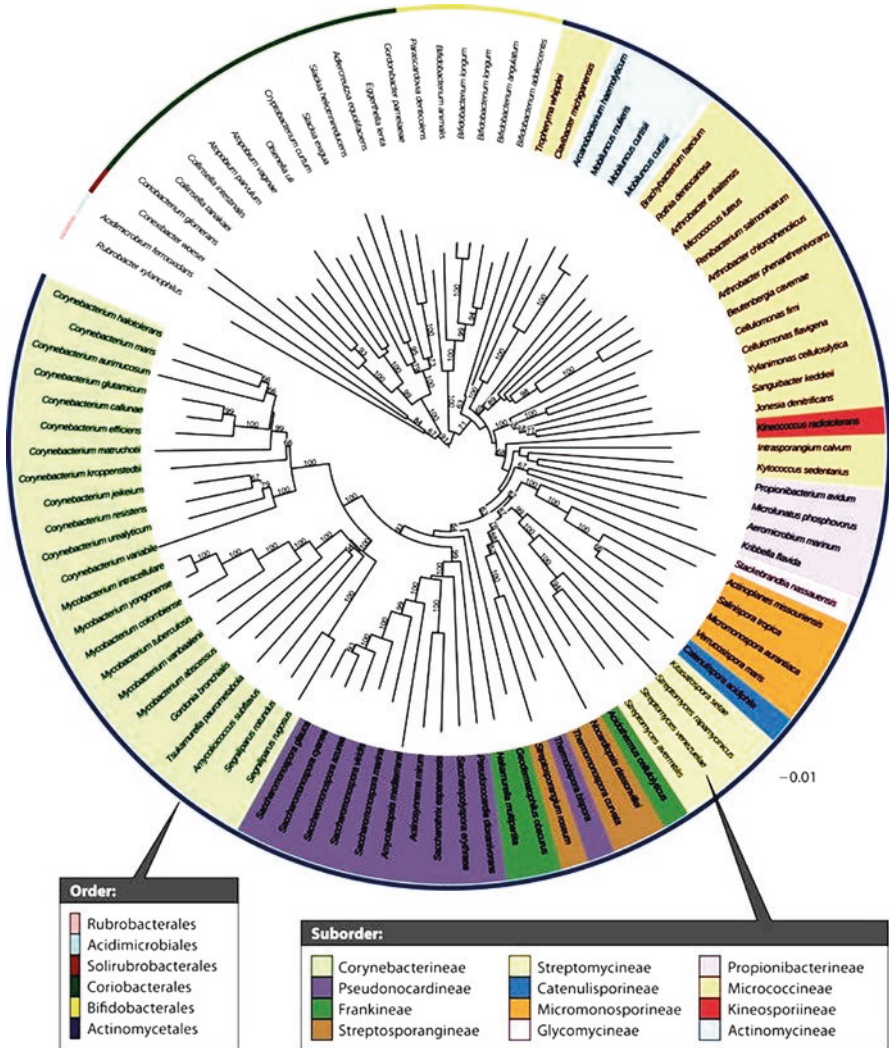
## 4.1 Current Status in Actinobacterial Taxonomy

Taxonomic position of the phylum *Actinobacteria* is proposed well through the 16S rRNA analyses. There are six classes in the phyla *Actinobacteria* including *Rubrobacteria*, *Thermoleophilia*, *Coriobacteriia*, *Acidimicrobiia*, *Nitriliruptoria*, and *Actinobacteria*, 5 subclasses, 6 orders, and 14 suborders (Ludwig et al. 2012). The order *Actinomycetales* belongs to the class *Actinobacteria* that is now limited to the members of the family *Actinomycetaceae*. Therefore, while 43 families within the phylum *Actinobacteria* are classified to class *Actinobacteria*, the 5 other classes constitute only 10 families (Ludwig et al. 2012). The immense recent expansion in the development of genome sequence data has supplied detailed understandings of genome evolution and made it easier to categorize microorganisms at the level of genera and family accurately. Figure 4.1 indicates the phylogenetic tree of sequenced Actinobacterial genera.

The class *Actinobacteria* consists of orders that were previously organized as suborders within the order *Actinomycetales* such as *Bifidobacteriales* and *Jiangellales* (Zhi et al. 2009; Tang et al. 2011). In the class, two clades are present; the first clade includes orders *Actinopolysporales*, *Glycomycetales*, *Corynebacteriales*, *Micromonosporales*, *Jiangellales*, *Propionibacteriales*, and *Pseudonocardiales*, and the second clade consists of the orders *Actinomycetales*, *Kineosporiales*, *Bifidobacteriales*, and *Micrococcales*. In addition, the order *Frankiales* is not considered as a clade and forms independent lineages at the base of tree including families *Frankiaceae*, *Acidothermaceae*, *Cryptosporangiaceae*, *Nakamurellaceae*, *Geodermatophilaceae*, and *Sporichthyaceae* (Ludwig et al. 2012).

---

F. Mohammadipannah (✉) • M. Dehghaghi  
Department of Microbial Biotechnology, School of Biology and Center of Excellence in  
Phylogeny of Living Organisms, College of Science, University of Tehran, Tehran, Iran  
e-mail: [fmohammadipannah@ut.ac.ir](mailto:fmohammadipannah@ut.ac.ir)



**Fig. 4.1** A genome-based phylogenetic tree for 97 genome sequences of the phylum *Actinobacteria* (Barka et al. 2016)

### 4.2 Classic and Recent Criteria in Taxonomical Classification of *Actinobacteria*

Classification and taxonomy of *Actinobacteria* was primarily based on phenotypic criteria, in which limited characteristics of *Actinobacteria* like morphological, chemical, and physiological features were investigated. Morphology of colony, spores chain, color of substrate and aerial mycelium, and diffusible pigments are still important factors in differentiation of genera but do not provide adequate

information for classification of this phylum. The current classification of *Actinobacteria* is based on 16S rRNA sequences. However, there is wide attention in the use of other molecular markers to construct phylogenetic trees and resolve limitations accompanied by 16S rRNA gene-based classification. Notably, nucleotide variations in multiple rRNA operons and horizontal gene transfer of 16S rRNA genes tend to have relatively unstable relationships between taxa in phylogenetic trees (Sentausa and Fournier 2013).

The classification of prokaryotes currently is based on the combination of phenotypic, chemotaxonomic, and genotypic information that is called polyphasic taxonomy (Schleifer 2009). Phenotypic methods applied for taxonomy analysis include morphology, antigenic features, growth range, metabolic production, pathogenesis, and ecology of microorganism. While the extensive use of polyphasic taxonomic approaches has improved the taxonomy resolution of phylum *Actinobacteria*, there are remarkable problems in some genera like *Streptomyces* that 16S rRNA gene and phenotypic features are not always sufficient for new species description (Girard et al. 2013).

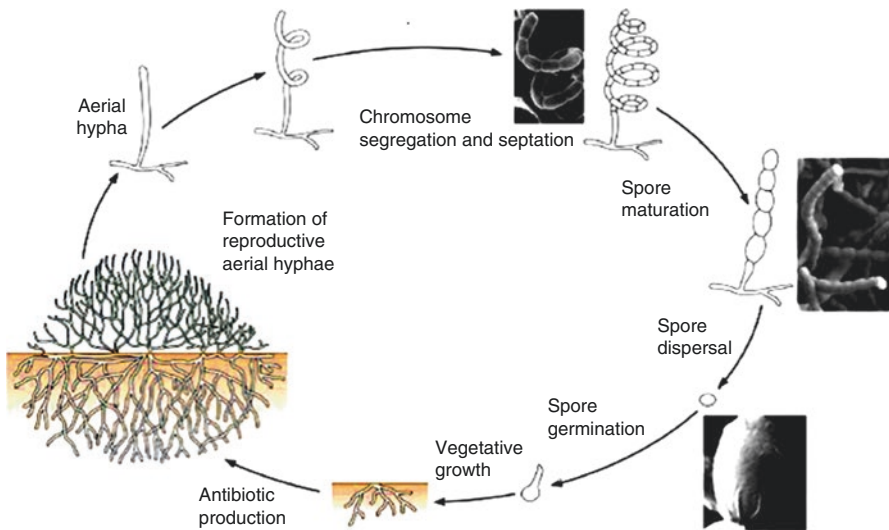
Whole genome sequences of bacteria have provided accurate information about bacterial systematics. Several genetic indices have been used to taxonomic analysis, remarkably DDH. The value of DDH of 70% has been suggested as a threshold for the description of species members. In addition, the average nucleotide identity (ANI) and multilocus sequence typing/multilocus sequence analysis (MLSA) have been recommended as alternative genetic taxonomic criteria (Konstantinidis and Tiedje 2005; Goris et al. 2007). Next-generation sequencing (NGS) method is rapidly increasing the number of sequenced bacteria, a faster approach that accelerates the accumulation of bacterial sequences data. Phylogenetic tree reconstruction using full genome provides more information and improves the resolution of relatedness between taxa.

---

## 4.3 Phenetic Classification

### 4.3.1 Microscopic and Macroscopic Morphology

Classification of *Actinobacteria* genera was primarily based on morphological features (Barka et al. 2016). Morphological characteristics are still fundamental criteria in description of different taxa, while they are not considered as sufficient determinants to individualize different genera. Standard media for the International Streptomyces Project have been used for cultivation and characterization of *Streptomyces* species (Shirling and Gottlieb 1966). These media are used to describe strain characteristics such as color of colony, spore, and aerial and substrate mycelium and diffusible pigment characteristics. Strains are cultivated in shaking flasks in liquid medium in standard condition and are transferred to the ISP media, which can be in microplate format. Growth, reverse color, aerial mycelium, spore production, and soluble pigment are described using RAL color code. The enzyme tyrosinase is responsible for the first step in the melanin biosynthesis and could only be



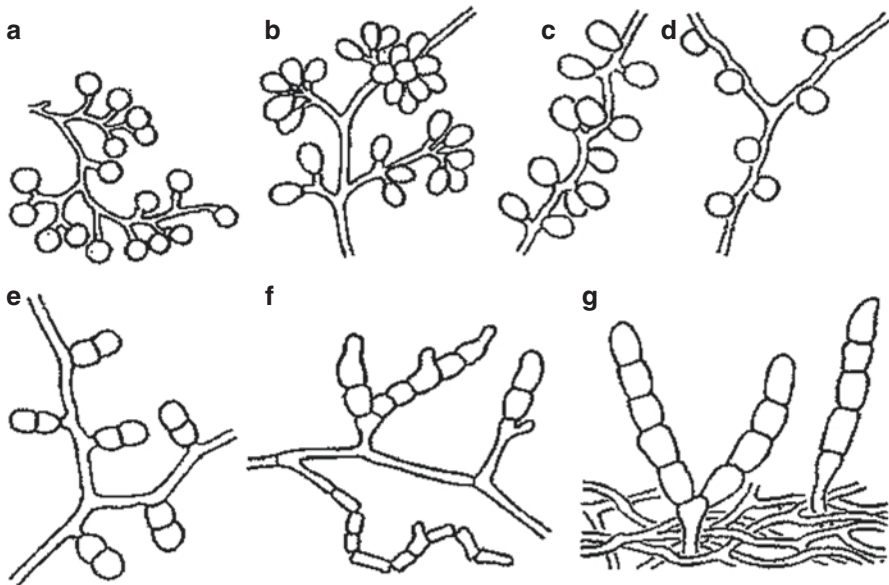
**Fig. 4.2** Life cycle of sporulating *Actinobacteria*

found in melanin-positive strains using the production assessment on ISP 6 and ISP 7 media. *Actinobacteria* represents diverse morphologies, including coccoid or rod-coccoid in *Micrococcus* and *Arthrobacter*, fragmented hyphae in *Nocardia* spp., and highly differentiated branched mycelium in *Streptomyces* spp. Figure 4.2 represents the life cycle of sporulating *Actinobacteria*.

Shape and structure of filaments are various according to the genus. For example, *Corynebacteria* do not form mycelia, while *Rhodococci* produce only elongated filaments without true mycelium (Locci and Schaal 1980; Flärdh 2003). In some species of *Actinomyces*, various morphologies of filaments, which may be totally straight or wavy with different degrees of branching, can be observed (Goodfellow 2012). A highly branched substrate mycelium is found in *Actinopolyspora* with mostly non-fragmented substrate hyphae. Simple to sophisticated branched substrate hyphae, which often are fragmented to rod-shaped and non-motile structures, occur in *Nocardia* members (Goodfellow 2012). The presence of spore chains, sporangia, and single spores, the fragmentation of aerial or substrate mycelium, or the type of spore chain morphology (recti-flexibilis, retinaculum-apertum spira, verticillus) are investigated in light microscopic characterization (Fig. 4.3).

*Actinobacteria* produce a variety of spore types either free or encapsulated in sporangia (Fig. 4.4) that are valuable in taxonomy of *Actinobacteria* (Goodfellow et al. 1984). Mostly, they form spores with hyphal origin that can be found singly or in chains of different lengths (Cross 1968).

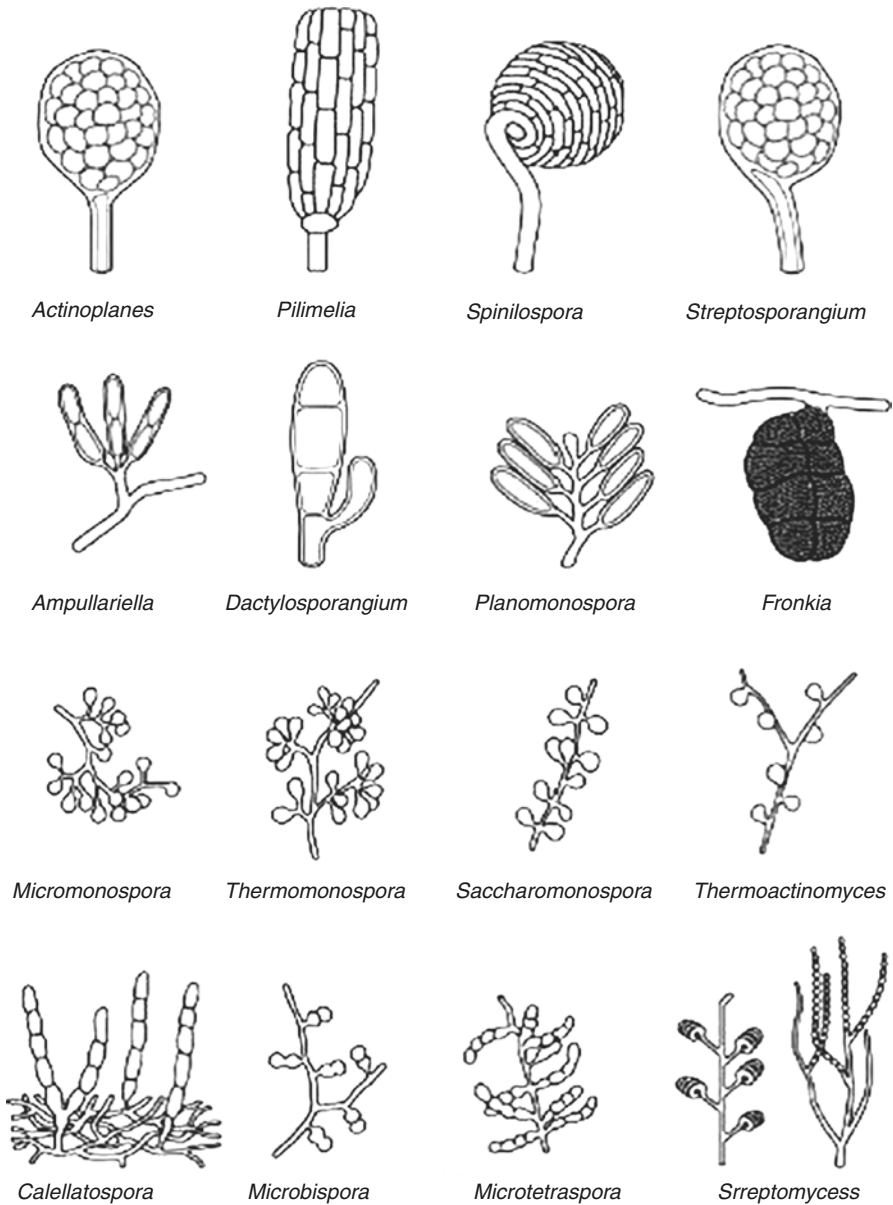
Surface of the spores themselves can also be used to distinguish between different species using scanning electron microscopy. They may be smooth, warty, spiny,



**Fig. 4.3** Types of spore chains in *Actinobacteria*

or hairy (Pridham et al. 1958). Long chains of spores are formed on aerial mycelium of genera *Streptomyces*, *Nocardiopsis*, and *Kitasatospora*, although in some species of genus *Streptomyces* short chains of large conidia are present on aerial mycelia. Some genera of *Actinobacteria* have sporangia with motile spores (*Oerskovia*, *Promicromonospora*, *Actinoplanes*), spores with flagella (*Ampullariella*), and spherical spores on the surface of colony (*Actinoplanes*), whereas *Cattellatospora* and *Glycomyces* form short chains of conidia without sporangia structure (Goodfellow 2012). The number of formed spores on spore chain is a critical factor in order to differentiate the genera. The genus *Microtetraspora* produces chains of conidia with 2–6 spores, while *Microbispora* forms chains with longitudinal pairs. The genera *Saccharopolyspora*, *Sporicthya*, and *Actinomadura* produce short spore chains, while *Streptomyces* species have long chains of spores (Pridham et al. 1958).

*Actinobacteria* produce several pigments that make differences in color of colonies, medium, and aerial mycelium based on their water solubility. These pigments are depicted in several colors including red, violet, green, yellow, gray, brown, and black. Production of pigments depends on medium substances, culture condition, and age of the strain. Melanins are polymers with diverse structures and produced by a broad range of organisms. These pigments are usually brown to black and are used in cosmetics and pharmaceutical products (Dastager et al. 2006). *Actinobacteria* members produce a dark pigment, melanin, which is considered valuable for taxonomic relatedness (Arai and Mikami 1972).



**Fig. 4.4** Morphological features of spores in different genera of *Actinobacteria* (Barka et al. 2016)

#### 4.4 Physiological/Metabolic Characteristics

Physiological characteristics are used for identification of *Actinobacteria* species based on their differences in physiological properties. Physiology and metabolism of *Actinobacteria* differ from one species to another, so they can be applied for

taxonomy studies. *Actinobacteria* are ubiquitous microorganisms that are found in a broad range of ecosystems. They are able to utilize macromolecules such as proteins, lignin, hemicellulose, chitin, and cellulose. *Actinobacteria* consume a variety of organic compounds and are able to grow on various substrates. Most of the genera are mesophilic, but there are some species that grow at high and low temperatures. Some are able to grow under acidic or alkaline conditions, while generally they prefer neutral pH (7.0–7.5). The physiological characteristic can be done in microplate format and automated monitoring of biology systems or ready strips of API® strips such as API Coryne and API ZYM or API 20 E. Growth similar or higher than the positive control is considered positive which even can be calculated by software such as OPM (Vaas et al. 2013). This section represents some important physiological aspects of *Actinobacteria* used in taxonomical description of *Actinobacteria*.

#### 4.4.1 Nutritional Requirements

Most *Actinobacteria* are chemoorganotrophic and non-fastidious microorganisms. All Actinobacterial members have glycolysis pathway (Embden-Meyerhof-Parnas) (Cochrane 1961). On the other hand, Entner-Doudoroff pathway is not used by *Actinobacteria*. Many *Actinobacteria* can switch between two pathways, glycolysis and hexose monophosphate shunt, during secondary metabolism (Kieser et al. 2000). They are able to use monosaccharides and disaccharides such as fructose, galactose, glucose, glycerol, maltose, mannitol, raffinose, rhamnose, sucrose, and xylose and polysaccharides like starch and cellulose as sole carbon source. Inorganic ( $\text{NH}_4^+$  or  $\text{NO}_3^-$ ) and organic (urea) nitrogen sources are used for growth. Degradation of compounds like esculin, Tween 80, xanthine, gelatin, and casein is observed among several genera (Goodfellow 2012). *Actinobacteria* synthesize various enzymes to hydrolyze organic compounds and macromolecules. Therefore, complex compounds like malt extract, oatmeal, and yeast extract increase the growth rate (Dworkin et al. 2005).

#### 4.4.2 Growth Conditions

##### 4.4.2.1 Temperature

The response of species to temperature variations is a valuable approach to differentiation of strains. The optimum temperature for most species of *Actinobacteria* is 25–35°C although several thermophilic and psychrophilic species have been described. Psychrophilic microorganisms grow between <0 and 20°C with optimum growth at <10°C, and psychrotolerants grow optimally at 7–15°C. Psychrophilic and psychrotolerant *Actinobacteria* are found in permafrost, sea ice, and saline springs of the Arctic; in permafrost, dry mineral soils, and lakes of the Antarctic; and in glaciers and ice-covered sites. *Actinobacteria* represent psychrophilic members in genera *Arthrobacter*, *Brachybacterium*, *Cryobacterium*, *Frigoribacterium*, *Glaciibacter*, *Kocuria*, and *Modestobacter*.

Thermophilic bacteria are categorized based on their temperature of growth. Facultative thermophiles grow between 50 and 65°C, and obligate thermophiles

can grow at temperatures between 65 and 70°C but do not grow below 40°C. Temperature variation has effect on spore's germination of thermophilic *Actinobacteria*. Germination of spores shows changes at temperatures above and below 55°C as high temperatures lead to reduction in the germination process (Foerster 1978).

Thermophilic *Actinobacteria* are obligate aerobe and chemoorganotrophs, although there are thermophilic genera such as *Streptomyces thermoautotrophicus* (Gadkari et al. 1990) and *Acidithiomicrobium* sp. (Norris et al. 2011) which they are obligate chemoautotrophs and grow in presence of CO<sub>2</sub> + H<sub>2</sub> and sulfur, respectively. Facultative chemoautotrophy in *Streptomyces* strain G26 (Bell et al. 1988) and facultative methylotrophy in *Amycolatopsis methanolica* (De Boer et al. 1990) have been recorded among thermophilic *Actinobacteria*.

#### 4.4.2.2 pH

Most *Actinobacteria* grow at neutrophilic conditions and at pH ranging from 5.0 to 9.0 where the optimum pH is 6.5–8.0; however, acidophilic and alkaliphilic genera have been described. The acidophilic *Actinobacteria* that grow optimally between pH values 1.8–4 belong to genera *Acidimicrobium*, *Ferrimicrobium*, *Ferrithrix*, *Aciditerrimonas*, *Acidothermus*, *Catenulispora*, *Streptacidiphilus*, and *Streptomyces* (Rosenberg et al. 2014). Studies showed that acidotolerant actinomycetes mostly are predominant in genera *Micromonospora* and *Streptomyces* variable in acidic soils (Zakalyukina et al. 2002).

Alkaliphilic *Actinobacteria* are classified in three categories: alkaliphilic (grow optimally at pH 10–11), moderately alkaliphilic (grow in a pH range of 7–10), and alkalitolerant *Actinobacteria* (grow in the pH range between 6 and 11). Alkaliphilic *Actinobacteria* occur in haloalkaliphiles, haloalkalitolerants, or thermobiotic environments (Shivlata and Satyanarayana 2015). Alkaliphilic genera include *Arthrobacter*, *Cellulomonas*, *Corynebacterium*, *Dietzia*, *Janibacter*, *Jiangella*, *Kocuria*, *Zhihengliuella*, *Nesterenkonia*, *Nocardiopsis*, *Nitriliruptor*, *Gordonida*, *Marmoricola*, and *Streptomyces* (Rosenberg et al. 2014).

#### 4.4.2.3 NaCl Tolerance

Halophilic and halotolerant *Actinobacteria* investigations clearly indicate the relatively heterogeneous physiological characteristics among different genera. *Actinobacteria* with halotolerant or halophilic characteristics and various requirements for salts that can be found in more than 66 genera from 28 families are reported. The highest percentage of halophilic or halotolerant species is found in *Nocardiopsis* genus with 16 halophilic species. The highest salt tolerance can be observed in *Actinopolyspora algeriensis* and *Actinopolyspora mzabensis*, with the ability to grow in the presence of up to 32% NaCl (w/v). The other species of this genus including *Actinopolyspora saharensis*, *Actinopolyspora halophila*, *Actinopolyspora egyptensis*, and *Actinopolyspora righensis* have optimum growth in 15–20% NaCl (w/v). The widest range for NaCl tolerance was reported in *Rubrobacter braccarensis* that tolerates 3–30% (w/v) salt concentration (Hamedi et al. 2015).



### 4.4.3 Antibiotic Sensitivity

The sensitivity toward different antibiotics is a helpful tool in differentiating between the species in *Actinobacteria*. The antibiotics susceptibility pattern of strains is one of the physiological parameters that can be used for classification of *Actinobacteria*.

### 4.4.4 Enzymatic Activity and Degradation Activity

*Actinobacteria* produce a wide variety of extracellular enzymes that are important for differentiation between species. Production of enzymes like lipase,  $\beta$ -glucosidase,  $\beta$ -galactosidase,  $\alpha$ -maltosidase, *N*-acetyl- $\beta$ -glucosaminidase, urease, trypsin, alkaline phosphatase, esterase, leucine arylamidase, cystine arylamidase, acid phosphatase, and  $\alpha$ -fucosidase has been evaluated for describing of Actinobacterial strains. Lignocellulolytic enzymes are secreted by *Actinobacteria* to hydrolyze lignocellulose, the most abundant biomass on earth. Among lignocellulase-producing *Actinobacteria*, *Cellulomonas fimi*, *Microbispora bispora*, and *Thermobifida fusca* have been described widely (Saini et al. 2015). Alkaline proteases are produced by some *Actinobacteria* members like *Streptomyces clavuligerus* (Thumar and Singh 2009), *Nocardiosis* sp. (Moreira et al. 2003), *Cellulosimicrobium cellulans* (Ferracini-Santos and Sato 2009), and *Saccharomonospora viridis* (Jani et al. 2012). Most *Streptomyces* species possess chitinase genes, enabling them to hydrolyze chitin in nature (Chater et al. 2010). Chitinolytic activity of *Actinoplanes philippinensis*, *Actinoplanes missouriensis*, and *Streptomyces clavuligerus* also has been used as biocontrol agent (Gadelhak et al. 2005).

---

## 4.5 Molecular Classification

### 4.5.1 16S rRNA Gene Sequence

Gene similarity in 16S rRNA has been considered as a significant molecular marker in taxonomy of prokaryotes due to it being universal, relatively stable, and highly conserved. Consequently, analysis of the 16S rRNA sequences has been kept as a preferable approach for classification of bacterial isolates. However, the 16S rRNA gene also shows limitations as a molecular marker including being highly conserved in some genera, nucleotide variations among multiple rRNA operons, and the possibility of horizontal gene transfer (HGT) of these genes between taxa (Ramasamy et al. 2014). The 16S rRNA gene similarity value has been suggested 97% for delineation of new species (Stackebrandt and Goebel 1994), but recently a cutoff value of 98.7–99% has been proposed for different orders (Stackebrandt and Ebers 2006). The EzTaxon server was developed to include the collection of all valid sequences which also provide calculation of pairwise similarity, multiple sequence alignment, and phylogenetic algorithms for tree construction (Chun et al. 2007).

### 4.5.2 Alternative Genes for Phylogenetic Analysis of *Actinobacteria*

Phylogeny of *Actinobacteria* involves alternative molecular markers that are mainly restricted to particular groups of this phylum. RpoB, RecA, DnaK, GrpE, GyrB, GroEL, YchF, RpoB, and SecY genes have been used to construct phylogenetic relationships between particular groups of *Actinobacteria* like bifidobacteria, mycobacteria, and *Streptomyces* members (Devulder et al. 2005; Guo et al. 2008; Leblond-Bourget et al. 1996; Shivannavar et al. 1996; Adékambi et al. 2011).

A multigene method was used to phylogenetic analysis of mycobacteria species by Devulder et al. (2005). In this study, the 16S rRNA gene as universal and conservative gene among bacteria, the gene *hsp65* that belongs to a family of heat shock protein (Hsp) genes which are present in all mycobacteria, the gene *rpoB* ( $\beta$ -subunit of RNA polymerase), and the gene *sod* (metalloenzyme) were subjected to phylogenetic analysis. The results indicated that the combination of different genes causes remarkable increases in the robustness of the phylogenetic tree in genus *Mycobacterium* (Devulder et al. 2005). The gene *rpoB*-based classification approach also was used for phylogenetic relationships of *Frankia* strains (Bernèche-D'Amours et al. 2011). The *gyrB* gene ( $\beta$ -subunit of DNA gyrase) was used for discrimination between *Kribbella*-type strains, which made a higher resolution compared to 16S rRNA gene (Kirby et al. 2010).

### 4.5.3 DNA-DNA Hybridization and ANI Value

Genomic approaches provide an accurate tool in description of bacteria. DNA-DNA hybridization (DDH) methods have been introduced since the 1960s, in order to assess the taxonomical relatedness of bacteria. Wayne et al. (1987) presented a value of 70% hybridization as a cutoff standard for species delineation. DDH main requirements include (1) comparison between the genomic DNA (gDNA) of the test bacterium and the gDNA of the type strain bacteria, (2) dissociation of both DNA double strands and DNA fragments, and (3) reannealing of fragments through temperature declining (Auch et al. 2010). The similarity indices in correlating with DDH value including genome BLAST distance phylogeny (GBDP) (Henz et al. 2005), average nucleotide identity (ANI), and the maximal unique matches index (MUMi) (Deloger et al. 2009) have introduced more efficiency compared to two genome sequences. Among these, Konstantinidis and Tiedje (2007) have proposed a higher range of threshold values according to the average nucleotide identity (ANI) of genome sequences which is based on a correlation between ANI and DDH values (Goris et al. 2007; Chan et al. 2012). ANI values between 95 and 96% are equal to DDH value of 70% and can be assumed for species discrimination (Goris et al. 2007; Richter and Rosselló-Móra 2009).

#### 4.5.4 Whole Genome Sequencing

Comprehension of prokaryote phylogeny has been extensively based on highly conserved small subunit rRNA (Woese 1987). Currently, complete genome sequencing is considered as a powerful tool in systematic of prokaryotes. Among the Actinobacterial species, *M. tuberculosis* was sequenced for the first time in 1998 (Cole et al. 1998). The features of some sequenced representatives of Actinobacterial genomes are summarized in Table 4.1. *Actinobacteria* have both circular and linear genome. Most of Actinobacterial genomes showed circular forms of genome, while in some genera like *Streptomyces*, *Actinomyces*, *Amycolatopsis*, *Actinoplanes*, *Streptoverticillium*, and *Micromonospora*, genomes were linear (Redenbach et al. 2000).

#### 4.5.5 Phylogeny of *Actinobacteria* Based on Whole Genome Analysis

For a long time, 16S rRNA gene has been used as an acceptable molecular marker to construct the prokaryotic phylogenetic tree (Woese and Fox 1977). In addition, other ribosomal RNA genes have also been applied to study bacterial taxonomy. Currently, phylogenetic analysis of phylum *Actinobacteria* is based on 16S rRNA gene and individual genes in case of particular groups. However, single-gene phylogeny seems to be unstable and cannot reflect the true evolutionary history of complex groups (Alam et al. 2010).

In contrast, whole genome-based phylogeny analysis shows the higher resolution of inner branches at species level and in addition eliminates the restrictions addressed in single-gene taxonomy analysis. Verma et al. (2013) have reconstructed a phylogenetic tree of 90 Actinobacterial genomes based on single genes (16S rRNA genes, 23S rRNA genes, and protein sequences of 94 conserved genes for single-based gene phylogeny) and whole genome sequences. Results of this approach showed inconsistencies in both maximum-likelihood trees and neighbor-joining trees of members of *Frankiales* and *Propionibacteriales* as they are not found to be in agreement with each other. Among the used methods, alignment-free phylogeny was found to be robust and reliable for phylogenetic studies of phylum *Actinobacteria* (Verma et al. 2013).

#### 4.5.6 Molecular Typing

##### 4.5.6.1 Pulsed-Field gel Electrophoresis (PFGE)

This technique relies on separation of large DNA fragments obtained by restriction enzymes. PFGE has been commonly used for genotyping and genetic fingerprinting especially in epidemiological studies of pathogenic bacteria (Besser 2015). PFGE has also been shown as a reliable and reproducible technique in typing of

**Table 4.1** Data of sequenced *Actinobacteria* genomes up to 2103

<i>Actinobacterium</i>	Genome size (bp)	%G+C content	Number of ORFs	Number of rRNA operons	Reference
<i>Amycolatopsis mediterranei</i> U32	10,236,715	71.3	9228	4	Zhao et al. (2010)
<i>Bifidobacterium longum</i> NCC2705	2,266,000	60	1730	4	Schell et al. (2002)
<i>Corynebacterium diphtheriae</i> NCTC 13129	2,488,635	53.5	2320	5	Cerdeño-Tárraga et al. (2003)
<i>Corynebacterium efficiens</i> YS-314	3,147,090	63.4	2950	5	Nishio et al. (2003)
<i>Corynebacterium glutamicum</i> ATCC 13032	3,309,401	53.8	2993	5	Ikeda and Nakagawa (2003)
<i>Corynebacterium jeikeium</i> K411	2,462,499	61.4	2104	3	Tauch et al. (2005)
<i>Frankia alni</i> ACN14a	7,497,934	72	6786	2	Normand et al. (2007)
<i>Frankia</i> sp. strain Cc13	5,433,628	70	4618	2	NCBI source NC_007777
<i>Frankia</i> sp. strain QA3	7,590,853	72.6	6493	3	Sen et al. (2013)
<i>Kocuria rhizophila</i> DSM 11926	2,697,540	71.6	2357	3	Takarada et al. (2008)
<i>Leifsonia xyli</i> subsp. <i>xyli</i> CTCB07	2,584,158	67.7	2351	1	Monteiro-Vitorello et al. (2004)
<i>Mycobacterium avium</i> subsp. <i>paratuberculosis</i> K-10	4,829,781	69.3	4350	1	Li et al. (2005)
<i>Mycobacterium bovis</i> AF2122/97	4,345,492	65.6	3953	1	Garnier et al. (2003)
<i>Mycobacterium leprae</i> TN	3,268,203	57.7	1605	1	Cole et al. (2001)
<i>Mycobacterium marinum</i>	6,636,827	65.7	5424	1	Stinear et al. (2008)
<i>Mycobacterium tuberculosis</i> H37Rv	4,411,532	65.6	3994	1	Cole et al. (1998)
<i>Mycobacterium tuberculosis</i> CDC1551	4,403,836	65.6	4250	1	Fleischmann et al. (2002)
<i>Mycobacterium</i> sp. (strain MCS)	5,705,448	68	5391	2	NCBI source NC_008146
<i>Nocardia farcinica</i> IFM10152	6,021,225	70.8	5674	3	Ohnishi et al. (2008)
<i>Propionibacterium acnes</i> KPA171202	2,560,265	60	2297	3	Brüggemann et al. (2004)
<i>Propionibacterium freudenreichii</i> CIRM-BIA1	2,616,384	67	2439	2	Falentin et al. (2010)
<i>Saccharopolyspora erythraea</i> NRRL23338	8,212,805	71.1	7264	4	Oliynyk et al. (2007)

**Table 4.1** (continued)

<i>Actinobacterium</i>	Genome size (bp)	%G+C content	Number of ORFs	Number of rRNA operons	Reference
<i>Streptomyces coelicolor</i> A3	8,667,507	72	7769	6	Bentley et al. (2002)
<i>Streptomyces avermitilis</i> MA-4680	9,025,608	70	7577	6	Ikeda et al. (2003)
<i>Streptomyces griseus</i> IFO 13350	8,545,929	72.2	7138	6	Ohnishi et al. (2008)
<i>Thermobifida fusca</i> YX	3,642,249	67	3110	4	Lykidis et al. (2007)
<i>Tropheryma whipplei</i> TW08/27	925,938	46	783	1	Bentley et al. (2003)
<i>Tropheryma whipplei</i> Twist	927,303	46	808	1	Raoult et al. (2003)

nonpathogenic bacteria. This method has been used for tracing the evolutionary history (Ventura et al. 2007) and chromosome diversity or similarity assessment within *Actinomycetales* (Kirby 2011). This technique has been applied for differentiation of clinically important *Nocardia* species in order to control the spread of nocardial diseases (Blümel et al. 1998). Clinical isolates of *Mycobacterium* strains involved in prevalent outbreaks (*M. abscessus*, *M. chelonae*, and *M. fortuitum*) have been studied for their patterns in PFGE profiles using restriction endonucleases *AseI*, *DraI*, and *XbaI* (Zhang et al. 2004).

#### 4.5.6.2 Multilocus Sequence Typing (MLST)

Multilocus sequence typing (MLST) is a molecular technique for characterization of bacterial species using variations in internal housekeeping gene fragments. MLST provides opportunity to investigate the evolution and population structure of bacteria (Maiden 2006). MLST has presented an approach to assist in identification and classification of some genera in subclass *Actinobacteridae* including *Mycobacterium*, *Microbacterium*, *Bifidobacterium*, *Microbispora*, and *Streptomyces*. A core set of genes for MLST analysis of subclass *Actinobacteridae* has been introduced that include *ychF*, *rpoB*, and *secY* genes which has shown to be a valid tool for identification and taxonomic analysis of this subclass (Adékambi et al. 2011). *Streptomyces* is a complex genus in phylum *Actinobacteria*, and systematic of this group is exceptionally important due to their industrial significance. A multilocus sequence analysis using six housekeeping genes including *atpD*, *gyrB*, *recA*, *rpoB*, *trpB*, and 16S rRNA from 53 valid strains has been performed for *Streptomyces griseus*. Studies demonstrated that multilocus sequence analysis is accurate and can be used for other *Streptomyces* species identification (Guo et al. 2008).

*Streptomyces albus* subsp. *albus* NRRL B-1811<sup>T</sup> comprises a cluster accompanied with four other species including *S. almquistii*, *S. flocculus*, *S. gibsonii*, and *S. rangoonensis*. Multilocus sequence analysis using housekeeping genes of

*atpD*, *gyrB*, *recA*, *rpoB*, and *trpB* was used to differentiate nearly identical 16S rRNA genes species and suggested a reclassification of *Streptomyces* species (Labeda et al. 2014).

Phytopathogenic *Streptomyces* members also have been classified using MLST method recruiting four housekeeping genes, *atpD*, *recA*, *rpoB*, and *trpB*. Also this method was applied in identification of strains isolated from plants without the need to conduct DNA-DNA hybridization (Labeda 2011).

Although most classification of the genus *Microbispora* is based on 16S rRNA gene sequences, phylogenetic trees of this genus have difficulties in taxonomic analysis and are not reliable. 16S-*gyrB*-*rpoB* gene sequences have also been used in classification of *Microbispora* species. Taxonomic analysis based on MLST showed significant probability support (Savi et al. 2016).

#### 4.5.6.3 Random Amplified Polymorphism Deoxyribonucleic Acid (RAPD)

RAPD detects available polymorphism between strains by showing differences among amplified DNA fragments. This method is used as a powerful tool for gene mapping, phylogenetic analysis, and bacterial identification (Micheli et al. 1994). This method has already been used successfully for differentiation of *Mycobacterium tuberculosis* isolates in epidemiological studies. Application of RAPD technique for region separating the genes 16S and 23S rRNA of *M. tuberculosis* isolates indicated higher resolution compared to whole genome-based RAPD (Abed et al. 1995). This method has been used for developing specific probes for *Streptomyces* genus and also a strain-specific probe for *Streptomyces lydicus* WYEC108 (Roberts and Crawford 2000). *Actinobacteria* producing hydrolytic enzymes have been identified by the RAPD fingerprinting using 20 different primers as *Streptomyces* genus (Boroujeni et al. 2012).

#### 4.5.6.4 Ribotyping

Ribotyping method is applied in taxonomic analysis, epidemiological, and population studies. In silico genomic analysis revealed that the observed polymorphisms indicate restriction fragment length polymorphisms (RFLPs) of the housekeeping genes existed in flank chromosomal rRNA gene sequences (Bouchet et al. 2008). *Nocardia* species may cause granulomatous and systematic infections in human in soft tissues, skin, pulmonary tracts, and the brain. Ribotyping of *Nocardia asteroides* and related strains has been developed in 1996, and four ribotypes were identified (Eshraghi 2015). Ribotyping provides a rapid approach for detection of pathogenic *Nocardia* strains. In another study, clinically significant *Nocardia* strains were distinguished using ribotyping method by a combination of *EcoRV* gene restriction endonuclease patterns plus an rDNA probe that categorized them in 19 different groups (Işik and Goodfellow 2010). Automated ribotyping has been used for identification of thermophilic *Actinobacteria* isolated from pulp and recycled fiber. Accordingly, this method showed reproducibility in discrimination of *Nocardiosis* and *Streptomyces* species (Suihko et al. 2006).

#### 4.5.6.5 MALDI-TOF Mass Spectrometry

Matrix-assisted laser desorption ionization time-of-flight mass spectrometry (MALDI-TOF MS) is considered as an accurate and reliable method in differentiation of Actinobacterial species. According to the taxonomic studies, polyphasic identification of *Streptomyces* species has been proven to be time-consuming and expensive. MALDI-TOF MS was applied by Loucif et al. (2014) for rapid identification of *Streptomyces* species isolated from environmental samples. This study revealed that whole cell protein extraction of *Streptomyces* cells with trifluoroacetic acid provided reproducible spectra for MALDI-TOF MS and resolved the challenge of filamentous nature of *Streptomyces* species (Loucif et al. 2014).

MALDI-TOF MS was used for identification of clinically important *Actinobacteria* such as *Corynebacterium*, *Actinomyces*, *Bifidobacterium*, and *Propionibacterium* genera. The study showed the reliability of MALDI-TOF MS in identification of Gram-positive bacteria (Schulthess et al. 2014). In addition, specificity of MALDI-TOF MS has been proved for identification of *Mycobacterium* and *Nocardia* species (Buckwalter et al. 2016).

---

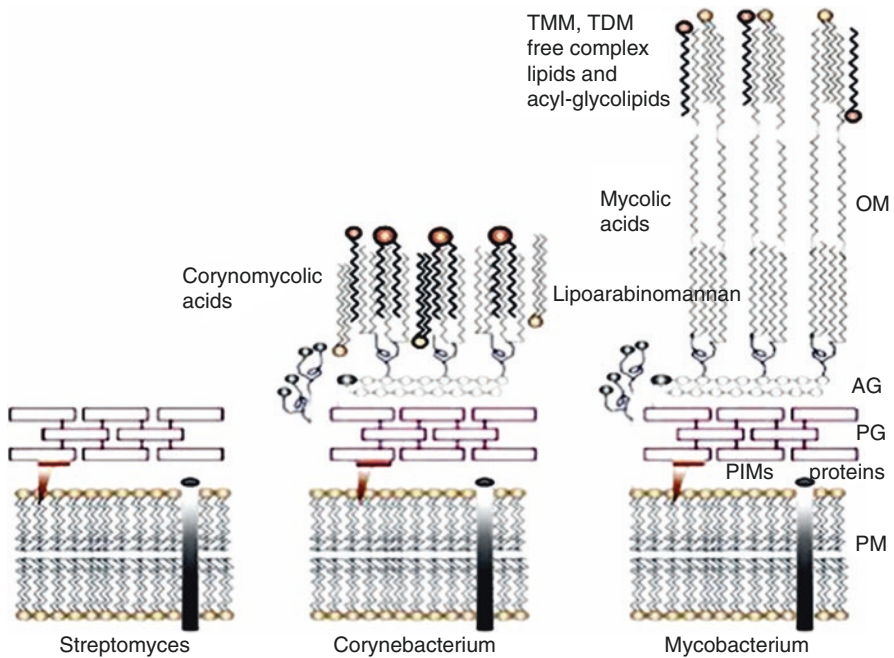
## 4.6 Chemical Classification

Chemotaxonomy refers to study of chemical components of cells which are used in classification of microorganisms (Goodfellow and Minnikin 1985). The chemical constituents of Actinobacterial cells have played an important role in the classification of these Gram-positive bacteria (Lechevalier et al. 1971). The most important bacterial cell components in chemotaxonomy studies are cell wall fatty acids, amino acids, menaquinones, sugars, and ratio of DNA bases (Goodfellow and O'Donnell 1989; Williams 1989). In this section, main chemical parameters that are critical in taxonomy of *Actinobacteria* are presented.

### 4.6.1 Cell Wall Chemical Composition

*Actinobacteria* could be classified into distinct groups at the generic level based on their cell wall composition. For such classification, the cell wall amino acids and whole cell sugars have become widely applied as the taxonomic markers (Prauser 1976).

The cell walls of Actinobacterial species depict the usual structure and chemical constituents of other Gram-positive bacteria (Schleifer and Kandler 1972). They show a homogeneous layer with 16–35 nm thickness under electron microscope. The peptidoglycan, which accounts for 20% of the cell dry weight, contains  $\beta$ 1–4 linked *N*-acetylglucosamine and *N*-acetylmuramic acid. Tetrapeptide L-Ala–D-Glu–LLA2pm–D-Ala is present in cell wall of *Streptomyces* cross-linked by pentaglycine bridge from the D-alanine to the amino group of the D-carbon of LLA2pm (Schleifer and Kandler 1972). The position three in the peptide side chain of *Actinobacteria* is placed by lysine, meso-DAP, or LL-DAP. The cell wall



**Fig. 4.5** Comparison of the cell wall structures from *Streptomyces*, *Corynebacterium*, and *Mycobacterium*. In *Streptomyces*, as in other Gram-positive bacteria, the cell wall consists of a peptidoglycan layer (PG) that covers the cytoplasmic membrane (PM)

compositions change during sporulation as in submerged mycelium LL-DAP and glycine (wall chemotype I) occur, while in spores, only *meso*-DAP could be found (wall chemotype III) (Takahashi et al. 1984).

The cell wall of *Actinobacteria* as in other Gram-positive bacteria consists of a peptidoglycan, although in some genera such as *Mycobacterium*, *Nocardia*, *Corynebacterium*, and *Rhodococcus*, it is composed of a peptidoglycan containing a thick layer meso-diaminopimelic acid linked to arabinogalactan. This layer is esterified by long-chain fatty acids, which are known as mycolic acids (Fig. 4.5).

Sugars could be detected in the whole cell hydrolysates that are part of the cell wall polysaccharides and based on four sugar patterns recognized in *Actinobacteria*. In some cases, xylose, galactose, and arabinose were reported as diagnostic sugars. In *Streptomyces* members, typically mannose, ribose, and glucose were recorded in small amounts (Dworkin et al. 2005). Five sugar patterns have been described in classification of mesodiaminopimelic acid containing *Actinobacteria* (Lechevalier et al. 1971), on the basis of the presence of certain sugars (arabinose and galactose; madurose; no diagnostic sugars; arabinose and xylose; rhamnose), although, in general, eight cell wall chemotypes (Table 4.2) have been described according to the combination of the amino acids and cell wall sugars to differentiate *Actinobacteria*.



**Table 4.2** Different types of cell wall components in *Actinobacteria* (Barka et al. 2016)

Cell wall type	Major components	Genera
I	LL-DAP, glycine, no sugar	<i>Arachnia</i> , <i>Nocardiooides</i> , <i>Pimelobacter</i> , <i>Streptomyces</i>
II	<i>meso</i> -DAP, glycine, arabinose, xylose	<i>Actinomyces</i> , <i>Actinoplanes</i> , <i>Ampulariella</i> , <i>Catellatosporia</i> , <i>Dactylosporangium</i> , <i>Glycomyces</i> , <i>Micromonospora</i> , <i>Pilimelia</i>
III	<i>meso</i> -DAP, madurose (3- <i>O</i> -methyl-D-galactose)	<i>Actinocorallia</i> , <i>Actinomadura</i> , <i>Dermatophylus</i> , <i>Frankia</i> , <i>Geodermatophilus</i> , <i>Kitasatospora</i> , <i>Maduromycetes</i> , <i>Microbispora</i> , <i>Microtetraspora</i> , <i>Nonomuraea</i> , <i>Planobispora</i> , <i>Planomonospora</i> , <i>Planotetraspora</i> , some <i>Frankia</i> spp., <i>Spirillosporina</i> , <i>Streptosporangium</i> , <i>Thermoactinomyces</i> , <i>Thermomonospora</i>
VI	<i>meso</i> -DAP, arabinose, galactose	<i>Micropolyspora</i> , <i>Nocardioforms</i>
V	Deprived of DAP; possesses lysine and ornithine	<i>Actinomyces</i>
VI	Deprived of DAP; variable presence of aspartic acid, galactose	<i>Arcanobacterium</i> , <i>Actinomyces</i> , <i>Microbacterium</i> , <i>Oerskovia</i> , <i>Promicromonospora</i>
VII	Deprived of DAP; diaminobutyric acid, glycine, with lysine variable	<i>Agromyces</i> , <i>Clavibacter</i>
VIII	Deprived of DAP; ornithine	<i>Aureobacterium</i> , <i>Curtobacterium</i> , <i>Cellulomonas</i>

#### 4.6.2 Cell Membrane Isoprenoid Quinones

Menaquinones are classified as respiratory compounds that are present in the cytoplasmic membranes of many bacteria and play an important role in electron transport chain. Menaquinones are the only type of isoprenoid quinones present in *Actinobacteria*. However, the type of structure of these compounds can be applied for the Actinobacterial taxonomy (Collins and Jones 1981). Parameters that are taxonomically important cover methylation and demethylation, length, and degree of saturation of the C-3 side chain and side chain cyclization of menaquinones (Collins et al. 1988). Most *Actinobacteria* represent quinones with saturated isoprenoid side chain at position 3 of the naphthoquinone ring. *Streptomyces* members have highly hydrogenated isoprenoid chains, and three to four isoprene units usually are saturated (Dworkin et al. 2005). Table 4.3 represents the major menaquinones of different families of *Actinobacteria*.

#### 4.6.3 Cell Membrane Phospholipids

Phospholipids are the most important polar lipids in bacterial cell membranes, including phosphatidylcholine, phosphatidylethanolamine, phosphatidylglycerol, diphosphatidylglycerol, phosphatidylserine, phosphatidylinositol, and

**Table 4.3** Major menaquinones of Actinobacterial families (Goodfellow 2012)

Family	Major menaquinones
<i>Acidimicrobiaceae</i>	MK-9(H8)
	MK-10(H10)
	MK-(H8)
<i>Actinomycetaceae</i>	MK-9
	MK-10(H4)
	MK-9(H4)
	MK-8
<i>Actinopolysporaceae</i>	MK-9(H4)
<i>Beutenbergiaceae</i>	MK-8(H4)
<i>Actinospicaceae</i>	MK-9(H6)
	MK-9(H4)
	MK-9(H8)
<i>Cellulomonadaceae</i>	MK-9(H4)
	MK10(H4)
<i>Conexibacteraceae</i>	MK-7 or derivatives
<i>Patulibacteraceae</i>	MK-7 or derivatives
<i>Solirubrobacteraceae</i>	MK-7 or derivatives
<i>Coriobacteriaceae</i>	DMMK-6
	MK-6
<i>Corynebacteriaceae</i>	MK-8(H2)
	MK-9(H2)
<i>Cryptosporangiaceae</i>	MK-9(H6)
<i>Dermabacteraceae</i>	MK 7
	MK8 or MK9
<i>Dermatophilaceae</i>	MK-8(H4)
<i>Dietziaceae</i>	MK-8(H2)
<i>Gaiellaceae</i>	MK-7
<i>Geodermatophilaceae</i>	MK-9(H4)
<i>Glycomycetaceae</i>	MK10(H4), MK10(H6)
	MK11(H4), MK11(H6)
<i>Iamiaceae</i>	MK-9(H4) or MK-9(H8)
<i>Intrasporangiaceae</i>	MK-8(H4)
<i>Jonesiaceae</i>	MK-9
<i>Ruaniaceae</i>	MK-8(H4)
<i>Bogoriellaceae</i>	MK-8(H4)
<i>Kineosporiaceae</i>	MK-9(H4)
	MK-9(H2), or MK-8(H2)
<i>Micrococcaceae</i>	MK-7
	MK-8
	MK-9
	MK-10
<i>Micromonosporaceae</i>	MK-9
	MK-10

**Table 4.3** (continued)

Family	Major menaquinones
<i>Mycobacteriaceae</i>	MK-9(H2)
<i>Nakamurellaceae</i>	MK-8(H4)
<i>Nocardiaceae</i>	MK-8(H4) cyclo
	MK-9(H2)
	MK-8(H2)
<i>Nocardioideaceae</i>	MK-8(H4)
	MK9(H6)
	MK-10(H6)
<i>Nocardiopsaceae</i>	MK-10(H8)
<i>Promicromonosporaceae</i>	MK-9(H4)
<i>Propionibacteriaceae</i>	MK-9(H4)
<i>Pseudonocardiaceae</i>	MK-9(H4)
<i>Rubrobacteraceae</i>	MK-8
<i>Sanguibacteraceae</i>	MK-9(H4)
<i>Rarobacteraceae</i>	MK-9
<i>Segniliparaceae</i>	MK-8(H4)
	MK-8(H2)
<i>Sporichthyaceae</i>	MK-9(H6)
	MK-9(H8)
<i>Streptomycetaceae</i>	MK-9(H6)
	MK-9(H8)
<i>Streptosporangiaceae</i>	MK-9(H2)
	MK-9(H4)
	MK-9(H6)
<i>Thermoleophilaceae</i>	MK-7(H4)
<i>Tsakamurellaceae</i>	MK-9

other phosphatidylglycolipids (Wang and Jiang 2016). Phospholipid composition of cell membrane has been studied for taxonomic classification of *Actinobacteria*, and five main groups of phospholipid typing have been described (Table 4.4). Diphosphatidylglycerol could be found in most members of *Actinobacteria*, while phosphatidylcholine is rarely found in *Actinobacteria*. Phosphatidylethanolamine, phosphatidylinositol, and phosphatidylinositol mannosides are detected in most of *Actinobacterial* species, while phosphatidylglycerol is less abundant. Members of genera *Micromonospora*, *Mycobacterium*, *Nocardia*, *Microellbosporia*, *Actinoplanes*, and *Streptomyces* contain phosphatidylethanolamine as a major phospholipid. Phosphatidylcholine is present in genera *Actinomadura*, *Micropolyspora*, *Nocardia*, and *Pseudonocardia*, and phosphatidyl methylethanolamine is also found in this group. Phospholipids containing glucosamine occur in genera *Microbispora*, *Streptosporangium*, *Oerskovia*, and *Promicromonospora* (Lechevalier et al. 1977). In addition, heptadecenoic acid has never been found in major forms of phospholipids in

**Table 4.4** Phospholipid types of Actinobacteria cell membrane (Lechevalier et al. 1977)

Phospholipid types	Characteristic phospholipid	Genus
P I	No nitrogenous phospholipids	<i>Actinomadura</i> , <i>Corynebacterium</i> , <i>Microtetraspora</i> , <i>Nocardioides</i>
P II	Only one nitrogenous phospholipid phosphatidylethanolamine	<i>Actinoplanes</i> , <i>Chania</i> , <i>Dactylosporangium</i> , <i>Microellobosporia</i> , <i>Micromonospora</i> , <i>Micropolyspora</i> , <i>Mycobacterium</i> , <i>Nocardia</i> , <i>Streptomyces</i>
P III	Phosphatidylcholine and characteristic phospholipid	<i>Actinomadura</i> , <i>Micropolyspora</i> , <i>Nocardia</i> , <i>Pseudonocardia</i>
P VI	Glucosamine-containing phospholipids	<i>Intrasporangium</i> , <i>Microbispora</i> , <i>Streptosporangium</i> ,
P V	Phosphatidylglycerol and glucosamine-containing phospholipids	<i>Oerskovia</i> , <i>Promicromonospora</i>

*Actinobacteria* but is present in other bacteria (O'Leary 1975). Some species of *Actinomadura*, *Corynebacterium*, *Microtetraspora*, and *Nocardioides* contain no major amounts of nitrogen-containing phospholipids (Lechevalier et al. 1977).

#### 4.6.4 Cell Membrane Fatty Acid Pattern

Fatty acid analysis of cell membrane contributes to characterization and classification of *Actinobacteria*. The differences in carbon chain length and the presence of saturated and unsaturated fatty acids, methyl groups, cyclopropane, and hydroxyl fatty acids are all considered as taxonomical values. Diagnostic fatty acids should constitute more than 2% of strain fatty acid content. Biosynthetic pathways of fatty acids have revealed that branched fatty acids synthesis is present in *Actinobacteria*. 2-Methylbutyrate as substrate leads to *anteiso*-branched fatty acids, while *iso*-branched fatty acids with even and odd numbers of carbon atoms are composed from isovalerate and isobutyrate, respectively (Gago et al. 2011). Table 4.5 shows the different fatty acid patterns that have been found in *Actinobacteria*.

#### 4.6.5 Cell Membrane Mycolic Acid Type

Mycolic acids are  $\alpha$ -branched, or  $\beta$ -hydroxylated fatty acids form a second permeability barrier in cell wall of mycobacteria, and *Corynebacteria* mycoloyl residues are linked to arabinogalactan or trehalose to generate mycoloyl arabinogalactan and trehalose monomycolate and trehalose dimycolate, respectively (Brennan 2003). Mycolic acids are composed of very long-chain fatty acids (carbon chains between 60 and 90) in *Mycobacterium* species, while in other

**Table 4.5** Fatty acid patterns in Actinobacterial genera

	Type	1a	1b	1c	2a	2b	2c	2d	3a	3b	3c	3d	3e	3f	3g
Fatty acid															
Iso-15:		–	–	–	1	4 <sup>a</sup>	2	3	–	4 <sup>a</sup>	2	1	2	2	2
Anteiso-15:0		–	–	–	–	2	3	2	–	1	1	1	–	1	1
Iso-16:0		–	–	–	3 <sup>a</sup>	2 <sup>a</sup>	3 <sup>a</sup>	4 <sup>a</sup>	2 <sup>a</sup>	2 <sup>a</sup>	3 <sup>a</sup>	3 <sup>a</sup>	4 <sup>a</sup>	4 <sup>a</sup>	4 <sup>a</sup>
16:0		3 <sup>a</sup>	3 <sup>a</sup>	3 <sup>a</sup>	2	1	1	2	3	–	1	1	1	1	1
10-Methyl 16:0		–	2	–	–	–	–	–	1	–	–	–	–	–	–
Iso-17:0		–	–	–	1 <sup>a</sup>	3 <sup>a</sup>	1 <sup>a</sup>	2 <sup>a</sup>	1	2	1	1	1	1	1
Anteiso-17:0		–	–	–	1 <sup>a</sup>	1 <sup>a</sup>	2 <sup>a</sup>	2 <sup>a</sup>	–	2	1	3 <sup>a</sup>	1	1	2
17:0		–	–	–	1	–	–	1	1	1	2	1	–	2	1
17:1		–	–	–	1	–	–	1	1 <sup>a</sup>	2 <sup>a</sup>	1 <sup>a</sup>	1 <sup>a</sup>	1 <sup>a</sup>	2 <sup>a</sup>	1 <sup>a</sup>
10-Methyl 17:0		–	1	–	–	–	–	–	1 <sup>a</sup>	1 <sup>a</sup>	2 <sup>a</sup>	2 <sup>a</sup>	1 <sup>a</sup>	1 <sup>a</sup>	1 <sup>a</sup>
Iso-18:0		–	–	–	1	–	–	1 <sup>a</sup>	1	–	1	1	–	–	–
18:0		1 <sup>a</sup>	1 <sup>a</sup>	1 <sup>a</sup>	–	–	–	1 <sup>a</sup>	1	–	1	1	–	–	–
18:1		3 <sup>a</sup>	3 <sup>a</sup>	2 <sup>a</sup>	–	–	–	2 <sup>a</sup>	2 <sup>a</sup>	1	–	2 <sup>a</sup>	–	–	–
10-Methyl 18:0		–	3 <sup>a</sup>	–	–	–	–	–	2 <sup>a</sup>	–	–	2 <sup>a</sup>	–	–	–
OH2		–	–	–	2 <sup>a</sup>	–	v	–	–	–	2 <sup>a</sup>	–	–	1 <sup>a</sup>	1 <sup>a</sup>
Cyclo 19		–	–	2 <sup>a</sup>	–	–	–	–	–	–	–	–	–	–	–

1 = 1–5%, 2 = 5–15%, 3 = 15–25%, 4 > 25%, v = variable, usually less than 2%

<sup>a</sup>Diagnostic fatty acids

*Actinobacteria*, they contain complex of saturated and unsaturated fatty acids with shorter carbon chains (carbon chains between 22 and 36 in corynomycolic acid) (Minnikin and Goodfellow 1979).

## References

- Abed Y, Davin-Regli A, Bollet C, De Micco P (1995) Efficient discrimination of *Mycobacterium tuberculosis* strains by 16S-23S spacer region-based random amplified polymorphic DNA analysis. *J Clin Microbiol* 33(5):1418–1420
- Adékambi T, Butler RW, Hanrahan F, Delcher AL, Drancourt M, Shinnick TM (2011) Core gene set as the basis of multilocus sequence analysis of the subclass Actinobacteridae. *PLoS One* 6(3):e14792
- Alam MT, Merlo ME, Takano E, Breitling R (2010) Genome-based phylogenetic analysis of *Streptomyces* and its relatives. *Mol Phylogenet Evol* 54(3):763–772
- Arai T, Mikami Y (1972) Chromogenicity of *Streptomyces*. *Appl Microbiol* 23(2):402–406
- Auch AF, Jan M, Klenk H-P, Göker M (2010) Digital DNA-DNA hybridization for microbial species delineation by means of genome-to-genome sequence comparison. *Stand Genomic Sci* 2(1):117
- Barka EA, Vatsa P, Sanchez L, Gaveau-Vaillant N, Jacquard C, Klenk H-P, Clément C, Ouhdouch Y, van Wezel GP (2016) Taxonomy, physiology, and natural products of Actinobacteria. *Microbiol Mol Biol Rev* 80(1):1–43
- Bell J, Colby J, Williams E (1988) CO oxidoreductase from *Streptomyces* strain G26 is a molybdenum hydroxylase. *Biochem J* 250(2):605–612

- Bentley SD, Chater KF, Cerdeno-Tarraga A-M, Challis GL, Thomson N, James KD, Harris DE, Quail MA, Kieser H, Harper D (2002) Complete genome sequence of the model actinomycete *Streptomyces coelicolor* A3 (2). *Nature* 417(6885):141–147
- Bentley SD, Maiwald M, Murphy LD, Pallen MJ, Yeats CA, Dover LG, Norbertczak HT, Besra GS, Quail MA, Harris DE (2003) Sequencing and analysis of the genome of the Whipple's disease bacterium *Tropheryma whipplei*. *Lancet* 361(9358):637–644
- Bernèche-D'Amours A, Ghinet MG, Beaudin J, Brzezinski R, Roy S (2011) Sequence analysis of *rpoB* and *rpoD* gene fragments reveals the phylogenetic diversity of actinobacteria of genus *Frankia*. *Can J Microbiol* 57(3):244–249
- Besser J (2015) Pulsed-Field Gel Electrophoresis for Disease Monitoring and Control. In: Jordan K, Dalmasso M (eds), Pulse field gel electrophoresis. *Methods Mol Biol*, Humana Press, Series volume 1301, pp 3
- Blümel J, Blümel E, Yassin A, Schmidt-Rotte H, Schaal K (1998) Typing of *Nocardia farcinica* by pulsed-field gel electrophoresis reveals an endemic strain as source of hospital infections. *J Clin Microbiol* 36(1):118–122
- Boroujeni ME, Das A, Prashanthi K, Suryan S, Bhattacharya S (2012) Enzymatic screening and random amplified polymorphic DNA fingerprinting of soil *Streptomyces* isolated from Wayanad District in Kerala, India. *J Biol Sci* 12(1):43–50
- Bouchet V, Huot H, Goldstein R (2008) Molecular genetic basis of ribotyping. *Clin Microbiol Rev* 21(2):262–273
- Brennan PJ (2003) Structure, function, and biogenesis of the cell wall of *Mycobacterium tuberculosis*. *Tuberculosis* 83(1):91–97
- Brüggemann H, Henne A, Hoster F, Liesegang H, Wiezer A, Strittmatter A, Hujer S, Dürre P, Gottschalk G (2004) The complete genome sequence of *Propionibacterium acnes*, a commensal of human skin. *Science* 305(5684):671–673
- Buckwalter S, Olson S, Connelly B, Lucas B, Rodning A, Walchak R, Deml S, Wohlfiel S, Wengenack N (2016) Evaluation of matrix-assisted laser desorption ionization–time of flight mass spectrometry for identification of *Mycobacterium* species, *Nocardia* species, and other aerobic Actinomycetes. *J Clin Microbiol* 54(2):376–384
- Cerdeño-Tárraga A, Efstratiou A, Dover L, Holden M, Pallen M, Bentley S, Besra G, Churcher C, James K, De Zoysa A (2003) The complete genome sequence and analysis of *Corynebacterium diphtheriae* NCTC13129. *Nucleic Acids Res* 31(22):6516–6523
- Chan JZ, Halachev MR, Loman NJ, Constantiniidou C, Pallen MJ (2012) Defining bacterial species in the genomic era: insights from the genus *Acinetobacter*. *BMC Microbiol* 12(1):1
- Chater KF, Biró S, Lee KJ, Palmer T, Schrepf H (2010) The complex extracellular biology of *Streptomyces*. *FEMS Microbiol Rev* 34(2):171–198
- Chun J, Lee J-H, Jung Y, Kim M, Kim S, Kim BK, Lim Y-W (2007) EzTaxon: a web-based tool for the identification of prokaryotes based on 16S ribosomal RNA gene sequences. *Int J Syst Evol Microbiol* 57(10):2259–2261
- Cochrane V (1961) Physiology of actinomycetes. *Ann Rev Microbiol* 15(1):1–24
- Cole S, Brosch R, Parkhill J, Garnier T, Churcher C, Harris D, Gordon S, Eiglmeier K, Gas S, Barry CR (1998) Deciphering the biology of *Mycobacterium tuberculosis* from the complete genome sequence. *Nature* 393(6685):537–544
- Cole S, Eiglmeier K, Parkhill J, James K, Thomson N, Wheeler P, Honore N, Garnier T, Churcher C, Harris D (2001) Massive gene decay in the leprosy bacillus. *Nature* 409(6823):1007–1011
- Collins M, Jones D (1981) Distribution of isoprenoid quinone structural types in bacteria and their taxonomic implication. *Microbiol Rev* 45(2):316
- Collins MD, Kroppenstedt RM, Támaoka J, Komagata K, Kinoshita T (1988) Structures of the tetrahydrogenated menaquinones from *Actinomadura angiospora*, *Faenia rectivirgula*, and *Saccharothrix australiensis*. *Curr Microbiol* 17(5):275–279
- Cross T (1968) Thermophilic actinomycetes. *J Appl Bacteriol* 31(1):36–53
- Dastager S, Li W-J, Dayanand A, Tang S-K, Tian X-P, Zhi X-Y, Xu L-H, Jiang C-L (2006) Separation, identification and analysis of pigment (melanin) production in *Streptomyces*. *Afr J Biotechnol* 5(8):1131–1134

- De Boer L, Dijkhuizen L, Grobben G, Goodfellow M, Stackebrandt E, Parlett J, Whitehead D, Witt D (1990) *Amycolatopsis methanolica* sp. nov., a facultatively methylotrophic actinomycete. *Int J Syst Evol Microbiol* 40(2):194–204
- Deloger M, El Karoui M, Petit M-A (2009) A genomic distance based on MUM indicates discontinuity between most bacterial species and genera. *J Bacteriol* 191(1):91–99
- Devulder G, de Montclos MP, Flandrois J (2005) A multigene approach to phylogenetic analysis using the genus *Mycobacterium* as a model. *Int J Syst Evol Microbiol* 55(1):293–302
- Dworkin M, Falkow S, Rosenberg E, Schleifer K, Stacebrandt E (2005) *The Prokaryotes, Archaea and bacteria: Firmicutes, Actinomycetes*, vol 3. Springer, Heidelberg, p 998
- Eshraghi S (2015) Molecular typing of *Nocardia* species. *J Med Bacteriol* 1(1–2):38–45
- Falentin H, Deutsch S-M, Jan G, Loux V, Thierry A, Parayre S, Maillard M-B, Dherbécourt J, Cousin FJ, Jardin J (2010) The complete genome of *Propionibacterium freudenreichii* CIRM-BIA1 T, a hardy Actinobacterium with food and probiotic applications. *PLoS One* 5(7):e11748
- Ferracini-Santos L, Sato HH (2009) Production of alkaline protease from *Cellulosimicrobium cellulans*. *Braz J Microbiol* 40(1):54–60
- Flärdh K (2003) Growth polarity and cell division in *Streptomyces*. *Curr Opin Microbiol* 6(6):564–571
- Fleischmann R, Alland D, Eisen JA, Carpenter L, White O, Peterson J, DeBoy R, Dodson R, Gwinn M, Haft D (2002) Whole-genome comparison of *Mycobacterium tuberculosis* clinical and laboratory strains. *J Bacteriol* 184(19):5479–5490
- Foerster HF (1978) Effects of temperature on the spores of thermophilic actinomycetes. *Arch Microbiol* 118(3):257–264
- Gadelhak GG, El-Tarabily KA, AL-Kaabi FK (2005) Insect control using chitinolytic soil actinomycetes as biocontrol agents. *Int J Agric Biol* 7(4):627–633
- Gadkari D, Schricker K, Acker G, Kroppenstedt RM, Meyer O (1990) *Streptomyces thermoautotrophicus* sp. nov., a thermophilic CO- and H<sub>2</sub>-oxidizing obligate chemolithoautotroph. *Appl Environ Microbiol* 56(12):3727–3734
- Gago G, Diacovich L, Arabolaza A, Tsai S-C, Gramajo H (2011) Fatty acid biosynthesis in actinomycetes. *FEMS Microbiol Rev* 35(3):475–497
- Garnier T, Eiglmeier K, Camus J-C, Medina N, Mansoor H, Pryor M, Duthoy S, Grondin S, Lacroix C, Monsempe C (2003) The complete genome sequence of *Mycobacterium bovis*. *Proc Natl Acad Sci* 100(13):7877–7882
- Girard G, Traag BA, Sangal V, Mascini N, Hoskisson PA, Goodfellow M, van Wezel GP (2013) A novel taxonomic marker that discriminates between morphologically complex actinomycetes. *Open Biol* 3(10):130073
- Goodfellow M (2012) Phylum XXVI. Actinobacteria phyl. nov. In: *Bergey's manual® of systematic bacteriology*. Springer, New York, pp 33–2028
- Goodfellow M, Minnikin DE (1985) *Chemical methods in bacterial systematics*. Academic Press, London, pp 1–15
- Goodfellow M, O'Donnell A (1989) Search and discovery of industrially significant Actinomycetes. In: *Baumberg S, Hunter IS, Rhodes PM (eds) Microbial products: new approaches*, Society for General Microbiology Symposium No. 44. Cambridge University Press, Cambridge, pp 343–383
- Goodfellow M, Mordarski M, Williams ST (1984) *The biology of the Actinomycetes*. Academic Press, London
- Goris J, Konstantinidis KT, Klappenbach JA, Coenye T, Vandamme P, Tiedje JM (2007) DNA–DNA hybridization values and their relationship to whole-genome sequence similarities. *Int J Syst Evol Microbiol* 57(1):81–91
- Guo Y, Zheng W, Rong X, Huang Y (2008) A multilocus phylogeny of the *Streptomyces griseus* 16S rRNA gene clade: use of multilocus sequence analysis for streptomycete systematics. *Int J Syst Evol Microbiol* 58(1):149–159
- Hamedi J, Mohammadipanah F, Panahi HKS (2015) Biotechnological exploitation of Actinobacterial members. In: *Halophiles*. Springer, Cham, pp 57–143

- Henz SR, Huson DH, Auch AF, Nieselt-Struwe K, Schuster SC (2005) Whole-genome prokaryotic phylogeny. *Bioinformatics* 21(10):2329–2335
- Ikeda M, Nakagawa S (2003) The *Corynebacterium glutamicum* genome: features and impacts on biotechnological processes. *Appl Microbiol Biotechnol* 62(2–3):99–109
- Ikeda H, Ishikawa J, Hanamoto A, Shinose M, Kikuchi H, Shiba T, Sakaki Y, Hattori M, Ōmura S (2003) Complete genome sequence and comparative analysis of the industrial microorganism *Streptomyces avermitilis*. *Nat Biotechnol* 21(5):526–531
- İşik K, Goodfellow M (2010) Molecular fingerprinting of some clinically significant *Nocardia* and related strains by restriction polymorphism ribosomal RNA analyses. *Turk J Biol* 34(4):355–365
- Jani SA, Chudasama CJ, Patel DB, Bhatt PS, Patel HN (2012) Optimization of extracellular protease production from alkali thermo tolerant actinomycetes: *Saccharomonospora viridis* SJ-21. *Bull Environ Pharmacol Life Sci* 1(6):84–92
- Kieser TB, Bibb MJ, Buttner MJ, Chater KF, Hopwood DA (2000) Practical *Streptomyces* genetics. John Innes Foundation, Norwich
- Kirby R (2011) Chromosome diversity and similarity within the Actinomycetales. *FEMS Microbiol Lett* 319(1):1–10
- Kirby BM, Everest GJ, Meyers PR (2010) Phylogenetic analysis of the genus *Kribbella* based on the *gyrB* gene: proposal of a *gyrB*-sequence threshold for species delineation in the genus *Kribbella*. *Antonie Van Leeuwenhoek* 97(2):131–142
- Konstantinidis KT, Tiedje JM (2005) Genomic insights that advance the species definition for prokaryotes. *Proc Natl Acad Sci U S A* 102(7):2567–2572
- Konstantinidis KT, Tiedje JM (2007) Prokaryotic taxonomy and phylogeny in the genomic era: advancements and challenges ahead. *Curr Opin Microbiol* 10(5):504–509
- Labeda DP (2011) Multilocus sequence analysis of phytopathogenic species of the genus *Streptomyces*. *Int J Syst Evol Microbiol* 61(10):2525–2531
- Labeda D, Doroghazi J, Ju K-S, Metcalf W (2014) Taxonomic evaluation of *Streptomyces albus* and related species using multilocus sequence analysis and proposals to emend the description of *Streptomyces albus* and describe *Streptomyces pathocidini* sp. nov. *Int J Syst Evol Microbiol* 64(3):894–900
- Leblond-Bourget N, Philippe H, Mangin I, Decaris B (1996) 16S rRNA and 16S to 23S internal transcribed spacer sequence analyses reveal inter- and intraspecific *Bifidobacterium* phylogeny. *Int J Syst Evol Microbiol* 46(1):102–111
- Lechevalier H, Lechevalier MP, Gerber NN (1971) Chemical composition as a criterion in the classification of actinomycetes. *Adv Appl Microbiol* 14:47–72
- Lechevalier MP, De Bievre C, Lechevalier H (1977) Chemotaxonomy of aerobic actinomycetes: phospholipid composition. *Biochem Syst Ecol* 5(4):249–260
- Li L, Bannantine JP, Zhang Q, Amonsin A, May BJ, Alt D, Banerji N, Kanjilal S, Kapur V (2005) The complete genome sequence of *Mycobacterium avium* subspecies *paratuberculosis*. *Proc Natl Acad Sci U S A* 102(35):12344–12349
- Locci R, Schaal KP (1980) Apical growth in facultative anaerobic actinomycetes as determined by immunofluorescent labeling. *Zentralblatt für Bakteriologie 1 Abt Originale A, Medizinische Mikrobiologie. Infektionskrankheiten und Parasitologie* 246(1):112–118
- Loucif L, Bendjama E, Gacemi-Kirane D, Rolain J-M (2014) Rapid identification of *Streptomyces* isolates by MALDI-TOF MS. *Microbiol Res* 169(12):940–947
- Ludwig W, Euzéby J, Schumann P, Busse HJ, Trujillo ME, Kämpfer P, Whitman WB (2012) Road map of the phylum Actinobacteria. In: *Bergey's manual® of systematic bacteriology*. Springer, New York, pp 1–28
- Lykidis A, Mavromatis K, Ivanova N, Anderson I, Land M, DiBartolo G, Martinez M, Lapidus A, Lucas S, Copeland A (2007) Genome sequence and analysis of the soil cellulolytic actinomycete *Thermobifida fusca* YX. *J Bacteriol* 189(6):2477–2486
- Maiden MC (2006) Multilocus sequence typing of bacteria. *Annu Rev Microbiol* 60:561–588
- Micheli MR, Bova R, Pascale E, D'Ambrosio E (1994) Reproducible DNA fingerprinting with the random amplified polymorphic DNA (RAPD) method. *Nucleic Acids Res* 22(10):1921



- Minnikin D, Goodfellow M (1979) Lipid composition in the classification and identification of acid-fast bacteria, Society for Applied Bacteriology symposium series. Academic Press, London, pp 189–256
- Monteiro-Vitorello CB, Camargo LE, Van Sluys MA, Kitajima JP, Truffi D, Do Amaral AM, Harakava R, De Oliveira JC, Wood D, De Oliveira MC (2004) The genome sequence of the gram-positive sugarcane pathogen *Leifsonia xyli* subsp. *xyli*. *Mol Plant-Microbe Interact* 17(8):827–836
- Moreira K, Porto T, Teixeira M, Porto A, Lima Filho J (2003) New alkaline protease from *Nocardioopsis* sp.: partial purification and characterization. *Process Biochem* 39(1):67–72
- Nishio Y, Nakamura Y, Kawarabayasi Y, Usuda Y, Kimura E, Sugimoto S, Matsui K, Yamagishi A, Kikuchi H, Ikeo K (2003) Comparative complete genome sequence analysis of the amino acid replacements responsible for the thermostability of *Corynebacterium efficiens*. *Genome Res* 13(7):1572–1579
- Normand P, Lapierre P, Tisa LS, Gogarten JP, Alloisio N, Bagnarol E, Bassi CA, Berry AM, Bickhart DM, Choisine N (2007) Genome characteristics of facultatively symbiotic *Frankia* sp. strains reflect host range and host plant biogeography. *Genome Res* 17(1):7–15
- Norris PR, Davis-Belmar CS, Brown CF, Calvo-Bado LA (2011) Autotrophic, sulfur-oxidizing actinobacteria in acidic environments. *Extremophiles* 15(2):155–163
- O’Leary WM (1975) The chemistry of microbial lipids. *CRC Crit Rev Microbiol* 4(1):41–63
- Ohnishi Y, Ishikawa J, Hara H, Suzuki H, Ikenoya M, Ikeda H, Yamashita A, Hattori M, Horinouchi S (2008) Genome sequence of the streptomycin-producing microorganism *Streptomyces gri-seus* IFO 13350. *J Bacteriol* 190(11):4050–4060
- Oliynyk M, Samborsky M, Lester JB, Mironenko T, Scott N, Dickens S, Haydock SF, Leadlay PF (2007) Complete genome sequence of the erythromycin-producing bacterium *Saccharopolyspora erythraea* NRRL23338. *Nat Biotechnol* 25(4):447–453
- Prauser H (1976) Actinomycetes: the boundary microorganisms (Arai T, ed). Toppan Company, Tokyo
- Pridham T, Hesseltine C, Benedict R (1958) A guide for the classification of streptomycetes according to selected groups. Placement of strains in morphological sections. *Appl Microbiol* 6(1):52
- Ramasamy D, Mishra AK, Lagier J-C, Padhmanabhan R, Rossi M, Sentausa E, Raoult D, Fournier P-E (2014) A polyphasic strategy incorporating genomic data for the taxonomic description of novel bacterial species. *Int J Syst Evol Microbiol* 64(2):384–391
- Raoult D, Ogata H, Audic S, Robert C, Suhre K, Drancourt M, Claverie J-M (2003) Tropheryma whipplei twist: a human pathogenic Actinobacteria with a reduced genome. *Genome Res* 13(8):1800–1809
- Redenbach M, Scheel J, Schmidt U (2000) Chromosome topology and genome size of selected actinomycetes species. *Antonie Van Leeuwenhoek* 78(3–4):227–235
- Richter M, Rosselló-Móra R (2009) Shifting the genomic gold standard for the prokaryotic species definition. *Proc Natl Acad Sci* 106(45):19126–19131
- Roberts MA, Crawford DL (2000) Use of randomly amplified polymorphic DNA as a means of developing genus- and strain-specific *Streptomyces* DNA probes. *Appl Environ Microbiol* 66(6):2555–2564
- Rosenberg E, DeLong EF, Lory S, Stackebrandt E, Thompson F (2014) The prokaryotes: Actinobacteria. Springer, Berlin Heidelberg
- Saini JK, Saini R, Tewari L (2015) Lignocellulosic agriculture wastes as biomass feedstocks for second-generation bioethanol production: concepts and recent developments. *3 Biotech* 5(4):337–353
- Savi D, Aluizio R, Galli-Terasawa L, Kava V, Glienke C (2016) 16S-gyrB-rpoB multilocus sequence analysis for species identification in the genus *Microbispora*. *Antonie Van Leeuwenhoek* 109(6):801–815
- Schell MA, Karmirantzou M, Snel B, Vilanova D, Berger B, Pessi G, Zwahlen M-C, Desiere F, Bork P, Delley M (2002) The genome sequence of *Bifidobacterium longum* reflects its adaptation to the human gastrointestinal tract. *Proc Natl Acad Sci* 99(22):14422–14427

- Schleifer KH (2009) Classification of bacteria and archaea: past, present and future. *Syst Appl Microbiol* 32(8):533–542
- Schleifer KH, Kandler O (1972) Peptidoglycan types of bacterial cell walls and their taxonomic implications. *Bacteriol Rev* 36(4):407
- Schulthess B, Bloemberg GV, Zbinden R, Böttger EC, Hombach M (2014) Evaluation of the Bruker MALDI Biotyper for identification of Gram-positive rods: development of a diagnostic algorithm for the clinical laboratory. *J Clin Microbiol* 52(4):1089–1097
- Sen A, Beauchemin N, Bruce D, Chain P, Chen A, Davenport KW, Deshpande S, Detter C, Furnholm T, Ghodhbhane-Gtari F (2013) Draft genome sequence of *Frankia* sp. strain QA3, a nitrogen-fixing actinobacterium isolated from the root nodule of *Alnus nitida*. *Genome Announc* 1(2):e00103–e00113
- Sentausa E, Fournier PE (2013) Advantages and limitations of genomics in prokaryotic taxonomy. *Clin Microbiol Infect* 19(9):790–795
- Shirling ET, Gottlieb D (1966) Methods for characterization of *Streptomyces* species I. *Int J Syst Evol Microbiol* 16(3):313–340
- Shivannavar C, Katoch V, Sharma V, Patil M, Katoch K, Bharadwaj V, Sharma R, Bhatia A, Agrawal B (1996) Determination of mycobacterial phylogeny on the basis of immunological relatedness of superoxide dismutases. *Int J Syst Evol Microbiol* 46(4):1164–1169
- Shivlata L, Satyanarayana T (2015) Thermophilic and alkaliphilic Actinobacteria: biology and potential applications. *Front Microbiol* 6:1014
- Stackebrandt E, Ebers J (2006) Taxonomic parameters revisited: tarnished gold standards. *Microbiol Today* 33(4):152
- Stackebrandt E, Goebel B (1994) Taxonomic note: a place for DNA-DNA reassociation and 16S rRNA sequence analysis in the present species definition in bacteriology. *Int J Syst Evol Microbiol* 44(4):846–849
- Stinear TP, Seemann T, Harrison PF, Jenkin GA, Davies JK, Johnson PD, Abdellah Z, Arrowsmith C, Chillingworth T, Churcher C (2008) Insights from the complete genome sequence of *Mycobacterium marinum* on the evolution of *Mycobacterium tuberculosis*. *Genome Res* 18(5):729–741
- Suihko M-L, Kroppenstedt R, Stackebrandt E (2006) Occurrence and characterization of actinobacteria and thermoactinomycetes isolated from pulp and board samples containing recycled fibres. *J Ind Microbiol Biotechnol* 33(3):183–191
- Takahashi Y, Kuwana T, Iwai Y, Omura S (1984) Some characteristics of aerial and submerged spores of *Kitasatosporia setalba*. *J Gen Appl Microbiol* 30(3):223–229
- Takarada H, Sekine M, Kosugi H, Matsuo Y, Fujisawa T, Omata S, Kishi E, Shimizu A, Tsukatani N, Tanikawa S (2008) Complete genome sequence of the soil actinomycete *Kocuria rhizophila*. *J Bacteriol* 190(12):4139–4146
- Tang SK, Zhi XY, Wang Y, Shi R, Lou K, Xu LH, Li WJ (2011) *Haloactinopolyspora alba* gen. nov., sp. nov., a halophilic filamentous actinomycete isolated from a salt lake, with proposal of *Jiangellaceae* fam. nov. and *Jiangellineae* subord. nov. *Int J Syst Evol Microbiol* 61(1):194–200
- Tauch A, Kaiser O, Hain T, Goesmann A, Weisshaar B, Albersmeier A, Bekel T, Bischoff N, Brune I, Chakraborty T (2005) Complete genome sequence and analysis of the multiresistant nosocomial pathogen *Corynebacterium jeikeium* K411, a lipid-requiring bacterium of the human skin flora. *J Bacteriol* 187(13):4671–4682
- Thumar JT, Singh SP (2009) Organic solvent tolerance of an alkaline protease from salt-tolerant alkaliphilic *Streptomyces clavuligerus* strain Mit-1. *J Ind Microbiol Biotechnol* 36(2):211–218
- Vaas LA, Sikorski J, Hofner B, Fiebig A, Buddruhs N, Klenk H-P, Göker M (2013) opm: an R package for analysing OmniLog® phenotype microarray data. *Bioinformatics* 29(14):1823–1824
- Ventura M, Canchaya C, Tauch A, Chandra G, Fitzgerald GF, Chater KF, van Sinderen D (2007) Genomics of Actinobacteria: tracing the evolutionary history of an ancient phylum. *Microbiol Mol Biol Rev* 71(3):495–548
- Verma M, Lal D, Kaur J, Saxena A, Kaur J, Anand S, Lal R (2013) Phylogenetic analyses of phylum *Actinobacteria* based on whole genome sequences. *Res Microbiol* 164(7):718–728

- Wang Y, Jiang Y (2016) Chemotaxonomy of Actinobacteria. In: Dhanasekaran D, Jiang Y. Actinobacteria - Basics and Biotechnological Applications. InTech Press, pp 113–139
- Wayne L, Brenner D, Colwell R, Grimont P, Kandler O, Krichevsky M, Moore L, Moore W, Murray R, Stackebrandt E (1987) Report of the ad hoc committee on reconciliation of approaches to bacterial systematics. *Int J Syst Evol Microbiol* 37(4):463–464
- Williams S (1989) Genus *Streptomyces* Waksman and Henrici 1943. In: Williams ST, Sharpe ME, Holt JG (eds) *Bergey's manual of systematic bacteriology*, vol 4. Williams and Wilkins, Baltimore, pp 2452–2492
- Woese CR (1987) Bacterial evolution. *Microbiol Rev* 51(2):221
- Woese CR, Fox GE (1977) Phylogenetic structure of the prokaryotic domain: the primary kingdoms. *Proc Natl Acad Sci* 74(11):5088–5090
- Zakalyukina YV, Zenova G, Zvyagintsev D (2002) Acidophilic soil actinomycetes. *Microbiology* 71(3):342–345
- Zhang Y, Yakrus MA, Graviss EA, Williams-Bouyer N, Turenne C, Kabani A, Wallace RJ (2004) Pulsed-field gel electrophoresis study of *Mycobacterium abscessus* isolates previously affected by DNA degradation. *J Clin Microbiol* 42(12):5582–5587
- Zhao W, Zhong Y, Yuan H, Wang J, Zheng H, Wang Y, Cen X, Xu F, Bai J, Han X (2010) Complete genome sequence of the rifamycin SV-producing *Amycolatopsis mediterranei* U32 revealed its genetic characteristics in phylogeny and metabolism. *Cell Res* 20(10):1096–1108
- Zhi XY, Li WJ, Stackebrandt E (2009) An update of the structure and 16S rRNA gene sequence-based definition of higher ranks of the class Actinobacteria, with the proposal of two new sub-orders and four new families and emended descriptions of the existing higher taxa. *Int J Syst Evol Microbiol* 59(3):589–608

Horbal Lilya and Luzhetskyy Andriy

---

## 5.1 Introduction

The taxonomic order *Actinobacteria* includes soil-dwelling, free-living and saprophytic mycelial bacteria (*Streptomyces*, *Amycolatopsis*, *Actinoplanes*, *Nocardia*, *Micromonospora*, *Kitasatospora*), as well as the causative agents of tuberculosis and leprosy (*Mycobacterium tuberculosis* and *Mycobacterium leprae*). Because the hallmark of the former is the ability to produce over two-thirds of the naturally derived antibiotics, anti-tumour agents and immunosuppressants that are currently in use (Baltz 2008; Demain and Sanchez 2009), our chapter will mainly focus on these bacteria. They are characterised by a complex life cycle that starts with spore germination, the development of substrate mycelia and then the formation of aerial mycelia and spores, which are correlated with secondary metabolite production (SM) (Flärth and Buttner 2009; McCormick and Flärth 2012). The role of the latter in the host cell is still a subject of debate. The most widely distributed notion is that SMs play a role in “microbial communication” (Barka et al. 2015; Ostash et al. 2012). However, these molecules have a broad application in the medicinal, veterinary and agriculture setting. Thus, since the discovery of streptomycin, the first antibiotic isolated from mycelial *Actinobacteria* in 1940, these microorganisms have received a great deal of attention and saved millions of lives. However, because these bacteria are widely distributed in the environment and are well studied, there is a problem of the frequent “rediscovery” of the same chemical compounds (so-called low hanging fruits) (Bachmann et al. 2014; Katz and Baltz 2016). For

---

H. Lilya

Pharmaceutical Biotechnology, University of Saarland, 66123 Saarbrücken, Germany

L. Andriy (✉)

Pharmaceutical Biotechnology, University of Saarland, 66123 Saarbrücken, Germany

Helmholtz Institute for Pharmaceutical Research Saarland, 66123 Saarbrücken, Germany

e-mail: [Andriy.Luzhetskyy@helmholtz-hzi.de](mailto:Andriy.Luzhetskyy@helmholtz-hzi.de)

example, streptothricin is found in approximately 10% of randomly collected soil actinomycetes (Baltz 2008). Until the first *Streptomyces* genome was sequenced (Bentley et al. 2002), it was anticipated that one strain could produce no more than 3–4 metabolites, and thus, the notion that *Actinobacteria* are already exhausted as producers of new bioactive compounds was the dominant theory at the end of the twentieth century. This was one of the reasons why many pharmaceutical companies withdrew from drug discovery programmes. However, a new boost in this field of *Actinobacteria* came with the advent of relatively inexpensive next-generation sequencing (NGS) technologies. Based on the analysis of the huge amount of available genetic information, it became obvious that the chromosome of these bacteria contains a hidden wealth of secondary metabolite gene clusters, most of which are silent or poorly expressed under traditional screening conditions (Bentley et al. 2002; Ohnishi et al. 2008; Omura et al. 2001; Tokovenko et al. 2016). This gave birth to a new approach, currently known as “genome mining”, and it was realised that access to the genome sequence of a strain provides the possibility to unlock the biosynthetic potential of a microorganism using different molecular genetic approaches. In this chapter, we discuss the strategies and methodologies applied for the genome sequencing of *Actinobacteria* and the influence of the wealth of the genetic information obtained regarding the drug discovery field and approaches and genetic tools that are used for the rational strain improvement and the metabolic engineering of these bacteria.

---

## 5.2 Sequencing Technologies to Determine the Genetics of *Actinobacteria* and the General Features of Their Genomes

Mycelial *Actinobacteria* are bacteria with a complex life cycle that have huge genomes, in comparison with other known bacteria (Hopwood 2006; Reeves et al. 1998; Redenbach et al. 2000). The first *Streptomyces* genome of the best known representative of the genus, *Streptomyces coelicolor* A3(2), was sequenced in the late 1990s with the use of an automated dideoxynucleotide method developed by Sanger (Bentley et al. 2002; Mardis 2013). This was the most widely used technique at that time; however, it was too expensive and laborious to become a method of choice for routine whole-genome sequencing, which required the creation, sorting and sequencing of genomic libraries prior to full genome assembly (Bentley et al. 2002). Therefore, the urgent need for inexpensive and more accurate technologies, which provided the possibility of overcoming fragment cloning and amplification in *E. coli*, forced the development of second-generation sequencing (SGS). Of the latter, we included 454 pyrosequencing (by 454 Life Science) (Margulies et al. 2005; Loman et al. 2012), Solexa/Illumina (Illumina Inc.) (Lam et al. 2012), SOLiD (now Thermo Fisher Scientific/Life Technologies) and Ion Torrent (now Thermo Fisher Scientific/Life Technologies) (Mardis 2008; Quail et al. 2012). Currently, the first two are the technologies of choice because of their lower cost, high throughput and accuracy. SGS technologies rely on the sequencing of clusters of amplified molecules.

The initial third-generation sequencing (TGS) technology was launched in 2011 by Pacific Biosciences in California and referred to as “PacBio” (Eid et al. 2009). Another technology that is still in its developmental phase is the Oxford Nanopore Technologies (ONT) MinION (Laver et al. 2015). TGS technologies perform the sequencing of a single molecule in real time; therefore, only a small amount of starting material is required, there is no need for an amplification step, there are no cycles of polymerisation and termination, and it can provide a read length exceeding several kilobases. For instance, the longest single read of the MinION technology was 98 kb. However, the error-rate of the latter is 38.2%, which limits its ability to compete with the current sequencing technologies on the market. In addition, TGS performs direct RNA sequencing, whereas SGS sequences cDNA.

Currently, there are three technologies that are widely used for the de novo sequencing of genomes of mycelial *Actinobacteria*: 454 pyrosequencing, Illumina MiSeq and PacBio. In 2012, Illumina bested 454 sequencing with an increasingly high-accuracy read length, the highest output and the lowest cost per base. All of the above-mentioned technologies have their pros and cons. One main drawback of Illumina is the short length of the reads that very often lead to an inability to assemble long repetitive sequences found in the biosynthetic gene clusters of polyketide syntheses (PKS) and non-ribosomal peptide synthetases (NRPS), ribosomal RNA operons and terminal inverted repeats. In such clusters, regions with an identity close to 100% often exist (Gomez-Escribano et al. 2015). The problem of misassembly can be tackled using the sequencing of two different libraries of short and long insert sizes. PacBio provides an average read length over 10 kb, and it can thus easily resolve highly similar repetitive sequences. In addition, PacBio can successfully analyse stretches of sequences that are difficult to read, even by Sanger sequencing (Gomez-Escribano et al. 2015). The main limitation of PacBio technology is the resolution of the G and C homopolymers. This problem is mainly related to the assembly algorithm rather than the sequencing chemistry, and it leads to deletions and, as a consequence, frameshifts that can easily be solved using the “GC Frame Plot”, PCR-amplification and Sanger sequencing. The 454 sequencing technology has the same problem that leads to insertions and frameshifts.

To date, the genome of *Streptomyces leeuwenhoekii* was sequenced using both Illumina and PacBio technologies (Gomez-Escribano et al. 2015). Based on the obtained data, the authors proposed a new strategy to obtain a complete de novo sequence of a genome of interest. This strategy is based on the use of both technologies for genome sequencing, the assembly of both data sets and the use of the Illumina contigs to correct the PacBio nucleotide omissions/additions (Gomez-Escribano et al. 2015).

The development of relatively cheap NGS technologies with a high accuracy led to the explosion of actinobacterial genome sequencing. In the period from 2001 to 2003, only three actinobacterial genomes were sequenced. With the advent of SGS and TGS, the numbers greatly increased. Thus, in 2009 and 2014, 28 and 231 genomes were sequenced, respectively (Gomez-Escribano et al. 2015). In general, in the middle of 2014, there were 1203 complete and draft genomes of *Actinobacteria* available in the NCBI database.

Considering the sequencing data and the results of the molecular analysis, it is postulated that the chromosome of *Streptomyces* is linear with telomere-like structures, whereas the chromosomes of the representatives of *Saccharopolyspora*, *Amycolatopsis*, *Micromonospora* and *Actinoplanes* genera are circular (Oliynyk et al. 2007; Stegmann et al. 2014; Hirsch et al. 2013; Yamamura et al. 2012). However, it is important to emphasise that there is heterogeneity even within the same genus. For instance, the chromosome of *Amycolatopsis orientalis* is supposed to be linear, whereas the *Amycolatopsis mediterranei* chromosome is described as circular (Jeong et al. 2013; Redenbach et al. 2000; Zhao et al. 2010b). An identical observation was conducted for *Nocardia asteroides* (linear chromosome) and *Nocardia farcinica* (circular chromosome) (Redenbach et al. 2000; Ishikawa et al. 2004). The linearity of the *Streptomyces* chromosome was established by pulsed-field gel electrophoresis and other molecular analyses (Lin et al. 1993) including the presence of genes in the chromosome associated with the linearity, such as *tpg* (encoding terminal protein that is linked to the end of the chromosome), *tap* (which codes for a telomere-associated protein that is important for replication of the linear chromosome) and *ttr* (encoding protein that is present close to the end of chromosome and is important for its mobilisation) (Kirby 2011). Considering the fact that the linear chromosome of *Streptomyces* reverts to a circular form relatively easy and that the genetic machine needed for the replication and stable inheritance of the latter is present in the cell, it has been proposed that a linear chromosome was the result of the recombination event between the linear plasmid and an ancestral circular chromosome (Chen et al. 2002). There are only a few other known bacteria besides mycelial *Actinobacteria* that have linear chromosomes: *Agrobacterium tumefaciens* (Allardet-Servent et al. 1993) and *Borrelia* (Ferdows and Barbour 1989). The main features of the mycelial *Actinobacteria* chromosome are summarised in Table 5.1.

Based on the sequence data, mycelial *Actinobacteria* and *Myxobacteria* have the largest chromosomes and number of genes in their genomes (Table 5.1) (in comparison with other known bacteria). This may reflect the complex life cycle that includes the formation of substrate and aerial mycelium, the germination and formation of spores (McCormick and Flärth 2012), the complexity and variability of the soil environment that these bacteria inhabit and their huge secondary metabolite repertoire (Baltz 2011, 2016; Manivasagan et al. 2014). A 5.01 Mb *Streptomyces* sp. SPB74 genome contains 4933 predicted protein-coding sequences and is one of the smallest among the *Streptomyces* species sequenced to date (Kirby 2011). *Streptomyces bingchenggensis* and *Streptomyces rapamycinicus* NRRL5491 have the largest sequenced *Actinobacterial* genomes to date, which are 11.94 Mb and 12.7 Mb, respectively, and are composed of 10,023 and 10,425 predicted protein-coding sequences (Wang et al. 2010; Baranasic et al. 2013). Usually, the size of the *Actinobacteria* genome is 8.0–10.0 Mb (*S. coelicolor* A3(2), 8.7 Mb; *Streptomyces avermitilis* MA4680, 9.0 Mb; *Streptomyces griseus* IF13350, 8.5 Mb; *Amycolatopsis japonica*, 8.9 bp; *Actinoplanes missouriensis* 431(T), 8.7 bp; *Actinoplanes friulienensis*, 9.3 Mb; and *Sacch. erythraea*, 8.2 Mb) (Bentley et al. 2002; Omura et al. 2001; Ohnishi et al. 2008; Stegmann et al. 2014; Yamamura et al. 2012; Rückert et al.

**Table 5.1** Genome features of mycelial Actinobacteria

Features/strain	Topology	GC content, %	Genome length	CDs number	Assigned function	Hypothetical proteins or no function predicted	Plasmid	rRNA operon	tRNA	tmRNA	Number of gene clusters
<i>S. coelicolor</i>	Linear	72.1	8667.507	7769	5124	2645	2, free replicon	6	63	1	23
<i>S. albus</i>	Linear	73.3	6841.649	5832	4665	1172	0	7	66	1	22
<i>S. avermitilis</i>	Linear	70.7	9025.608	7574	4563	3011	1, linear	6	68	1	30
<i>S. griseus</i>	Linear	72.2	8545.929	7138	4464	2674	0	6	66	1	34
<i>S. fulvissimus</i>	Linear	71.5	7905.758	7027	5194	1833	0	6	73	-	32
<i>S. leeuwenhoekii</i>	Linear	73	7903.895	7057	4599	2458	2, circular and linear	6	65	-	34
<i>S. hygrosopicus</i>	Linear	71.9	10,145.833	8849	7362	1487	2, circular and linear	6	68	-	29
<i>S. bingchenggensis</i>	Linear	70.8	11,936.683	10,023	6419	3604	0	-	-	-	23
<i>Kutzneria albidia</i>	Circular	70.6	9874.926	8822	6648	2174	-	3	47	-	46
<i>A. mediterranei</i>	Circular	71.3	10,236.715	9228	6441	1913	2, integral	4	52	-	25
<i>A. japonica</i>	Circular	68.89	8961.318	8298			1	4	55	-	30
<i>Sacch. erythraea</i>	Circular	71.1	8212.805	7197	4777	2421	2, integral	4	50	1	25
<i>A. missouriensis</i>	Circular	70.82	8773.466	8204	5463	2741	0	6	58	1	-
<i>N. farcinica</i>	Circular	70.8	6021.225	5683	2962	1153	2, free replicon	3	53	-	14
<i>M. lupini</i>		71.96	7327.024	7054				10 genes	77	-	
<i>K. setae</i>	Linear	74.2	8783.278	7569	4049	3520	0	9	74	1	24



2014; Oliynyk et al. 2007), and the GC content is over 70%. In general, 70–80% of the predicted coding DNA sequences (CDS) have assigned putative functions, whereas the remaining 20–30% are annotated as genes that code for hypothetical proteins. The replication origin, *oriC*, which may contain up to 20 DnaA box-like sequences (Jakimowicz et al. 1998), is typically located in the middle of the chromosome. However, exceptions rarely occur, such as in the case of *S. avermitilis*, where 776 kb are shifted away from the centre and towards the right end of the chromosome (Ikeda et al. 2003). Generally, the chromosome consists of a “core” region that is 5–6 Mb and contains essential genes and variable “arms” regions or “contingency” loci coding for probable non-essential functions (Hopwood 2006). The *S. coelicolor* chromosome contains uneven “arms” that are approximately 1.5 Mb (left arm) and 2.3 Mb (right arm) long (Bentley et al. 2002). The size of the terminal inverted repeats (TIRs) in *S. coelicolor* is more than 1 Mb, whereas the length of the TIRs in *Streptomyces hygroscopicus* is only 14 bp, which is one of the shortest TIRs found in *Actinomycetes* (Wu et al. 2012). A comparative analysis of the *S. avermitilis* genome with *S. coelicolor* and other bacteria using pairwise BLASTP searches revealed that 5283 (69%) genes have orthologues in *S. coelicolor* A3(2), 1966 (26%) genes have orthologues in *M. tuberculosis* and only 21% have orthologues in *E. coli* (1593 genes) or *B. subtilis* (1586 genes) (Ikeda et al. 2003). A comparison of the core region of *S. coelicolor* A3(2) with the circular chromosome of *Mycobacterium tuberculosis* and *Corynebacterium diphtheriae* showed syntenic features in gene content and location (Bentley et al. 2002). Typically, *Actinobacteria* genomes contain six rRNA operons, more than 60 tRNA genes and one tmRNA gene (Table 5.1) (Ohnishi et al. 2008). However, there are exceptions: the chromosome of *S. albus* has seven operons that could be a reason for the fast growth of this strain (Zaburanyi et al. 2014); the chromosome of *Sacch. erythraea* with four sets of rRNA genes, each containing, unusually, a duplicated 5S rRNA gene (Oliynyk et al. 2007); and the chromosome of *Micromonospora* strain L5 with only two rRNA operons (Hirsch et al. 2013). An additional unique feature of the *Sacch. erythraea* genome is the presence of the *sel* operon (*selA-D*) for the production of selenocysteine tRNA, which recognises the UGA stop codon (Oliynyk et al. 2007).

The genomes of *Actinobacteria* show a strong emphasis on regulation that might be a consequence of the huge size of the former and reflect plasticity of these bacteria to complex and variable soil environments. On average, 9–15% of genes code for predicted regulatory proteins. The sigma factors are bacterial transcription initiation proteins that recruit RNA polymerase and enable its binding to a specific promoter. The genome of *E. coli*, which is on average twice as small as that of *S. coelicolor*, contains seven sigma factors (Blattner et al. 1997). There are 65 sigma factors in *S. coelicolor*, and 45 are extra-cytoplasmic function (“ECF”) sigma factors (Bentley et al. 2002). There are 94 putative sigma factors in the genome of *A. mediterranei*, and 80 of them are the “ECF” type. The *S. albus* chromosome contains 35 sigma factors, and 25 are “ECF”, which is the smallest number among fully annotated *Streptomyces* genomes. The genome of *Sacch. erythraea* codes for 38 potential sigma factors. Many genes encode for regulators that belong to different known families of regulatory proteins, namely, LysR, LacI, ROK, GntR, TetR, IclR, AraC, AsnC and MerR. There are

85 sensor kinases and 79 response regulators identified in the genome of *S. coelicolor*, which probably constitute regulatory pairs (Bentley et al. 2002), whereas the number of two component regulatory systems in the genome of *A. mediterranei* is greater with 89 paired and 43 unpaired (Zhao et al. 2010b). An interesting feature of *Actinobacteria* is the presence of serine/threonine kinases in their genomes (Bentley et al. 2002), which are notable hallmarks of eukaryotic genomes; however, they are also identified in some other bacteria but in a much smaller quantity.

The huge number of predicted transporters (8–10%) and secreted proteins (10%) reflects the ability of these bacteria to transport and utilise different nutrients from the soil and resist various drugs because some of the transporters are drug pumps.

Numerous resistance genes to different antibiotics, namely, vancomycin, moenomycin, beta-lactams, kirromycin, rifampicin, chloramphenicol, daunorubicin, bicyclomycin, camphor, tetracycline and indolmycin, have been identified in the genomes of *Actinobacteria* (Bentley et al. 2002; Oliynyk et al. 2007; Omura et al. 2001; Ohnishi et al. 2008). The multidrug resistance of these bacteria is most likely related to their ability to produce a variety of biologically active compounds.

On average, *Actinobacteria* chromosomes contain at least 20–25 gene clusters of potentially bioactive compounds and new chemical scaffolds that might be a source of new drugs (Bentley et al. 2002; Oliynyk et al. 2007; Omura et al. 2001; Ohnishi et al. 2008). Currently, the chromosome of *S. bingchengensis* contains 53 (Wang et al. 2013), that of *S. rapamycinicus* contains 52 (Baranasic et al. 2013) and that of *Kutzneria albida* contains 48 putative gene clusters (Rebets et al. 2014b). According to recent studies, bacteria with large genomes devote 0.8–3.0 Mb of their chromosomal DNA to secondary metabolite gene clusters (Baltz 2017). Therefore, with the combination of genome mining and approaches of synthetic biology, metabolic engineering has opened up a plethora of new interesting compounds that await discovery in these bacteria.

With the exception of linear chromosomes, most of the *Actinomycetes* genomes contain either linear or circular plasmids (Table 5.1). The largest linear plasmid currently identified is pSCL4 in the genome of *Streptomyces clavuligerus* ATCC 27064, which is known for the production of biotechnologically important secondary metabolites (Medema et al. 2010). The size of the plasmid is 1.8 Mb, and it does not contain genes essential for primary metabolism; however, it is packed with secondary metabolite gene clusters, namely, staurosporine, moenomycin, beta-lactams and enediynes. The genome of *S. hygrosopicus* 5008 contains two plasmids: one that is linear (164.57 kb) and one that is circular (73.28 kb) (Wu et al. 2012).

---

### 5.3 Reporter Genes for *Actinobacteria*

Most of the biosynthetic gene clusters identified by genome sequencing are silent in laboratory conditions. Therefore, an investigation and understanding of the regulatory mechanisms that control morphological differentiation and secondary metabolite production can open the way to new interesting bioactive compounds and scaffolds and help to construct strain-overproducers. Thus, there is a need for

reporters that permit the study and deciphering of the expression of genes from their promoters under different conditions and in the presence or absence of various regulatory proteins and other controlling elements (e.g. signals and ligands).

The application of *E. coli*'s LacZ as a reporter, which is easily observed and quantitatively detectable, revolutionised the field of gene expression assessment in prokaryotes. However, attempts to utilise LacZ as a reporter for mycelial *Actinobacteria* failed because most of them are characterised by quite high endogenous beta-galactosidase activity, and the mutants that were deprived of this activity were characterised by pleiotropic defects (Eckhardt et al. 1987). Therefore, other known reporters were adopted for these microorganisms, namely, EGFP, RFP, GusA, MelC, XylE, BpsA, RppA, Amy, Neo and Cat (Table 5.2). All of these systems have their own advantages and limits.

**Table 5.2** Reporter systems for mycelial *Actinobacteria*

Reporter	Description	Source
<i>gusA</i>	Codes for the beta-glucuronidase, performs conversion of beta-glucuronides into chromogenic, chemiluminescent or fluorescent products. Can be applied for quantitative and visual assessment of gene expression in solid and liquid media. Requires substrate	<i>E. coli</i>
<i>bpsA</i>	Codes for non-ribosomal peptide synthetase responsible for the biosynthesis of a blue pigment—indigoidine. Can be applied for quantitative and visual assessment of gene expression in solid and liquid media. Does not require addition of any substrate; however depends on endogenous presence of tryptophan	<i>S. aureofaciens</i>
<i>egfp</i>	Encodes enhanced green fluorescence protein. Can be detected in vivo and in vitro. The system is characterised by photobleaching and high background due to a high level of autofluorescence in mycelial <i>Actinobacteria</i> . In vivo quantification is not possible	Jellyfish <i>Aequorea victoria</i>
<i>mRFP</i>	Encodes for monomeric red fluorescence protein. Can be detected in vivo and in vitro. In vivo quantification is not possible	<i>Discosoma</i> sp.
<i>luxAB</i>	Code for the $\alpha$ - and $\beta$ -subunits of a heterodimer luciferase enzyme. This enzyme catalyses oxidation of long-chain aldehydes and reduced flavin mononucleotide. Requirement for the system is addition of the substrate— <i>n</i> -aldehyde decanal. Can be detected in vivo and in vitro. Quantitative measurement in vivo is possible	<i>Vibrio harvei</i>
<i>luxABCDE</i>	Code for the $\alpha$ - and $\beta$ -subunits of a heterodimer luciferase enzyme and for the proteins that produce a tetradecanal that is a substrate for the enzyme. The system is very sensitive; the enzyme is rapidly degradable that allows temporal investigation of gene expression. However, the enzymatic reaction is dependent on fatty acid pools, which vary in different growth conditions	<i>Photorhabdus luminescens</i>

**Table 5.2** (continued)

Reporter	Description	Source
<i>rppA</i>	Codes for type III polyketide synthase that is responsible for the production of 1,3,6,8-tetrahydroxynaphthalene which spontaneously oxidises to a dark-red quinone flaviolin. Visual assessment of gene expression as well as quantitative spectrophotometric measurement are possible. The system has low sensitivity and depends on the pool of malonyl-CoA in the cell	<i>Sacch. erythraea</i>
<i>amy</i>	Codes for $\alpha$ -amylase that is involved in starch digestion. Visual assessment of gene expression as well as quantitative spectrophotometric measurement are possible. Low sensitivity of a system	<i>Streptomyces griseus</i>
<i>xylE</i>	Encodes catechol 2,3-dioxygenase. Requires substrate catechol. Can be detected in vivo and in vitro. Low sensitivity	<i>Pseudomonas putida</i>
<i>melC</i>	Encodes for the tyrosinase operon involved in the biosynthesis of melanin. Can be detected in vivo and in vitro. Low sensitivity	<i>S. glaucescens</i>
<i>neo</i>	Codes for aminoglycoside phosphotransferase. Neomycin/kanamycin resistance. Activity can be detected in vivo and in vitro. Low sensitivity	Tn5
<i>cat</i>	Codes for chloramphenicol acetyltransferase from Tn9. Chloramphenicol resistance. Low sensitivity	Tn9

One of the most widely used reporters to date is based on the *gusA* gene that codes for beta-glucuronidase and performs the conversion of beta-glucuronides into chromogenic, chemiluminescent or fluorescent products (Myronovskyi et al. 2011). The GC content of the *gusA* gene from *E. coli* was adopted for *Actinobacteria*, which allowed the efficient expression of the gene and the application of its product as a versatile reporter in these bacteria. The GusA reporter system is easily used, and the substrates are inexpensive and do not require the presence of any additional cofactors, which provides an opportunity for the visual and quantitative analysis of gene expression. In addition, the enzyme is extremely stable and thus tolerant to various assay conditions (e.g. pH and temperature), and N- and C-terminal fusions to other proteins do not significantly impair its activity. Two vectors were reported for monitoring the expression of genes and operons at transcriptional and translational levels using the GusA reporter. The first one, pGUS, is used for transcriptional fusions with promoters (Myronovskyi et al. 2011). It is based on the pSET152 integrative vector (Kieser et al. 2000) containing promoterless *gusA*, an apramycin resistance gene and spectinomycin, which is surrounded with terminators to prevent a read-through. In certain cases, for instance, when there is a need to find mutants with increased expression of the gene of interest, it is important to have a reporter with reduced sensitivity that provides a distinct difference in the signal intensity only when the transcription level is significantly increased. Thus, variants of the *gusA* gene with different start codons (ATG, CTG and TTG), which are characterised by various sensitivities, have been created. The pGUSHL4aadA vector is used

to monitor a translation of the gene of interest (Myronovskyi et al. 2011). It is based on a pTESa marker-free integrative vector (Siegl et al. 2010) and contains the *gusA* gene without a start codon, the HL4 helical linker (Arai et al. 2001) and apramycin and spectinomycin resistance markers (Myronovskyi et al. 2011). Both vectors are efficiently used for the study of gene expression in various *Actinobacterial* strains (Myronovskyi et al. 2011; Siegl et al. 2013; Horbal et al. 2013a, b; Fleige and Steinbüchel 2014). In addition, the GusA reporter was successfully applied for the construction of the library of semi-synthetic constitutive promoters based on the *ermEp1* promoter (Siegl et al. 2013), theophylline riboswitch (Rudolph et al. 2013). This reporter system was also applied for the estimation of the heterologous promoter strength in the teicoplanin producer *Actinoplanes teichomyceticus* (Horbal et al. 2013b). In general and considering the data for GusA activity obtained in *Actinobacteria* and other prokaryotes, GusA seems to be the reporter that currently provides the highest level of sensitivity.

Considering that GusA activity can be easily visually detected, another utilisation of this system is for the selection of the second crossover events. For this purpose, two vectors, pKGLP2 and pKG1139, were created (Myronovskyi et al. 2011). Both of them contain multiple cloning sites (MCS) for the insertion of the DNA region of interest and the *gusA* reporter gene under the control of the thiostrepton promoter (*tipAp*). The main difference is that pKGLP2 is a suicide vector, and pKG1139 contains a thermo-sensitive origin of replication in actinomycetes. Utilisation of these vectors facilitates the selection of clones with the second crossovers. Thus, clones with the first crossover or that contain free plasmid will turn dark blue after being overlaid with 5-brom-4-chlor-3-indoxyl- $\beta$ -D-glucuronide; the clones with the second crossover will lose the backbone of the plasmid, and thus the *gusA* gene, and will become uncoloured.

Another relatively new reporter system was created based on a *bpsA* gene from *S. aureofaciens*, which encodes non-ribosomal peptide synthetase that is responsible for the biosynthesis of the blue pigment indigoidine (Knirschova et al. 2015). Two vectors were created. The pBPSA1 vector contains the promoterless *bpsA* gene and is used for the quantitative and visual assessment of gene expression. The other one, pAMR4, is for the gene inactivation and selection of the second crossover clones. The advantage of this system in comparison with GusA is that it does not require the addition of any substrate. However, it utilises and thus depends on the presence of endogenous tryptophan.

The other widely used system is based on the enhanced green fluorescence protein (EGFP) (Sun et al. 1999). Earlier attempts to utilise the wild-type green fluorescence protein (GFP) from the jellyfish *Aequorea victoria* as a reporter in *Streptomyces* failed and is most likely due to the relatively AT-rich nature of the former and the presence of three TTA codons in the gene, translation of which is developmentally regulated in these bacteria (Chandra and Chater 2008). EGFP contains two amino acid substitutions, namely, Ser65Thr and Phe64Leu, which enhance the fluorescence 35-fold in comparison with the wild-type GFP. The version of the *egfp* gene with optimised codon usage for mammals and without TTA codons was successfully adopted for the expression in mycelial *Actinobacteria* (Sun et al. 1999).

Several promoter-probe vectors, pIJ8630, pIJ8660 and pIJ8668, were constructed (Sun et al. 1999). All of them contain the promoterless *egfp* gene, the MCS poly-linker for promoter cloning and the apramycin resistance gene for selection. The pIJ8630 and pIJ8660 vectors site-specifically integrate into the chromosome through the *attP* site and the integrase gene (*int*) from the  $\phi$ C31 phage. pIJ8668 is a derivative of pIJ8660 that lacks the  $\phi$ C31 attachment site and the *int* gene and thus might be used for the transcriptional fusion between the *egfp* gene and the gene of interest at its native chromosomal locus via homologous recombination integration. The EGFP-based reporter system was used for the investigation of regulatory gene expression, protein localization and promoter assessment in various *Actinobacterial* strains: *S. coelicolor*, *Streptomyces globisporus*, *Streptomyces lividans*, *Streptomyces ansochromogenes* and *Actinoplanes friuliensis* (Sun et al. 1999; Rebets et al. 2005; Xie et al. 2007; Wagner et al. 2009). The main drawbacks of this system are photobleaching and high background due to a high level of autofluorescence in mycelial *Actinobacteria*.

Another fluorescence protein, the monomeric red fluorescence protein (mRFP1), which is a derivative of a red fluorescence protein (DsRed) from *Discosoma* sp., was adapted for use in *Actinobacteria* (Nguyen et al. 2007). The main advantage of the RFP reporter system over EGFP is that most of the mycelial *Actinobacterial* strains pose a much lower level of autofluorescence. Two integrative vectors, pMU-2 and pMU-3, containing the promoterless *mRFP* gene are available for promoter and gene fusions (Nguyen et al. 2007). They differ from each other by the integration system into a chromosome. For example, pMU-2 utilises the  $\phi$ C31-based integrase, whereas pMU-3 integrates via the  $\phi$ BT1 phage integration system. The mRFP1 protein was successfully applied for the investigation of cell type-specific gene expression and protein localization in *S. coelicolor* (Nguyen et al. 2007). The availability of two fluorescence reporters, EGFP and mFRP, enables their use in two-colour imaging and fluorescence resonance energy transfer (FRET).

A luciferase reporter system that is widely used for the temporal and spatial study of gene expression in prokaryotes has also been widely used in *Actinobacteria* (Schauer et al. 1988; Craney et al. 2007). The first luciferase reporter was developed based on the *luxA* and *luxB* genes from *Vibrio harveyi* encoding for the  $\alpha$ - and  $\beta$ -subunits of a heterodimer luciferase enzyme. This enzyme catalyses the oxidation of long-chain aldehydes and reduced flavin mononucleotide (FMN) ( $\text{FMNH}_2 + \text{RC HO} + \text{O}_2 = \text{FMN} + \text{RCOOH} + \text{H}_2\text{O} + \text{light}$ ) (Hastings and Gibson 1963). Because FMN is present in the cell, the only requirement for the system is the supplementation of the reaction mixture with long-chain aldehydes (*n*-aldehyde decanal). The latter can be added exogenously as a vapour and does not influence bacterial growth. The replicative pRS1105 vector contains the promoterless *luxAB* cassette and enables its use for transcriptional fusions. This vector was utilised for the assessment of gene expression of various genes including *bldA*, *sapA* and *endoH* (Schauer et al. 1988; Sohaskey et al. 1992). The main drawback of the *luxAB*-based system is the necessity to add a substrate exogenously. Therefore, another luciferase system that utilises *luxA*, *B*, *C*, *D* and *E* genes from *Photobacterium luminescens* was developed for use in *Actinobacteria* (Craney et al. 2007). The latter three proteins are

responsible for the production of a tetradecanal required for the reaction; therefore, there is no longer a need to supply it. The luciferase system has no background luminescence and is very sensitive. In addition, the enzyme is rapidly degradable, which allows the temporal investigation of gene expression, and it is tolerant to gene fusions; consequently, a spatial assessment of proteins is also possible. The main disadvantage of this system is the complexity of the enzymatic reaction and its dependence on fatty acid pools, which vary under different growth conditions.

Recently, an additional reporter system based on RppA from *Sacch. erythraea* was developed for mycelial *Actinobacteria* (Magdevska et al. 2010). RppA codes for the type III polyketide synthase that is responsible for the production of 1,3,6,8-tetrahydroxynaphthalene, which spontaneously oxidises to a dark-red quinone flaviolin and provides a visual assessment of gene expression and a quantitative spectrophotometric measurement. The system proved to be efficient and applicable to a wide range of *Streptomyces* strains: *S. coelicolor* and three industrially important species including *Streptomyces tsukubaensis*, *Streptomyces cinamonensis* and *Streptomyces rimosus*. However, the main drawback of the system is the low sensitivity and dependence on the pool of malonyl-CoA in the cell.

The *amy* gene from *S. griseus* coding for  $\alpha$ -amylase that is involved in starch digestion was adapted for use as a reporter in *Nocardia* strains (Chary et al. 1997). It is easy to determine its activity on solid agar plates based on the appearance of the starch digestion zones and in liquid culture by spectrophotometric assays. The Amy reporter system was used for the assessment of promoter activity in the cephamycin gene cluster (Chary et al. 1997). Despite the ease of the use and analysis of this reporter, its main drawback is low sensitivity in comparison with the other reporter systems, for instance, to the Gus system.

Several reporter systems based on neomycin or chloramphenicol resistance genes were previously developed for *Actinobacteria* (Cadenas et al. 1991; Hodge et al. 1995). The major drawback of these systems is low sensitivity, and thus, it is impossible to use them in quantitative assays. This is also a problem for the *xylE*-based reporter from *Pseudomonas putida*, which encodes catechol 2,3-dioxygenase (Ingram et al. 1989), and *melC* from *Streptomyces glaucescens*, which codes for the tyrosinase operon involved in the biosynthesis of melanin (Paget et al. 1994).

---

## 5.4 Vectors for Mycelial *Actinobacteria*

Molecular genetics approaches provide information regarding gene function, morphological differentiation, secondary metabolite production and the regulation of these processes and metabolic flux. This information could be used in metabolic engineering and biotechnology for rational strain improvement and drug discovery. The great variety of shuttle vectors provides an opportunity to integrate, delete or overexpress regions of the DNA of interest in *Actinobacteria*. There are three major types of vectors that are used for mycelial *Actinobacteria*: suicide vectors that can integrate into the genome by homologous recombination and might be used for gene inactivation; replicative vectors that contain the appropriate actinobacterial origin of replication and can thus be autonomously maintained in a cell; and integrative

vectors that site-specifically integrate into a genome using bacteriophage's integrase systems (Table 5.3, Fig. 5.1).

Non-replicative vectors (Fig. 5.1) are widely used for gene deletions and gene replacement experiments. Among the most popular suicide vectors for mycelial

**Table 5.3** Vectors for mycelial *Actinobacteria*

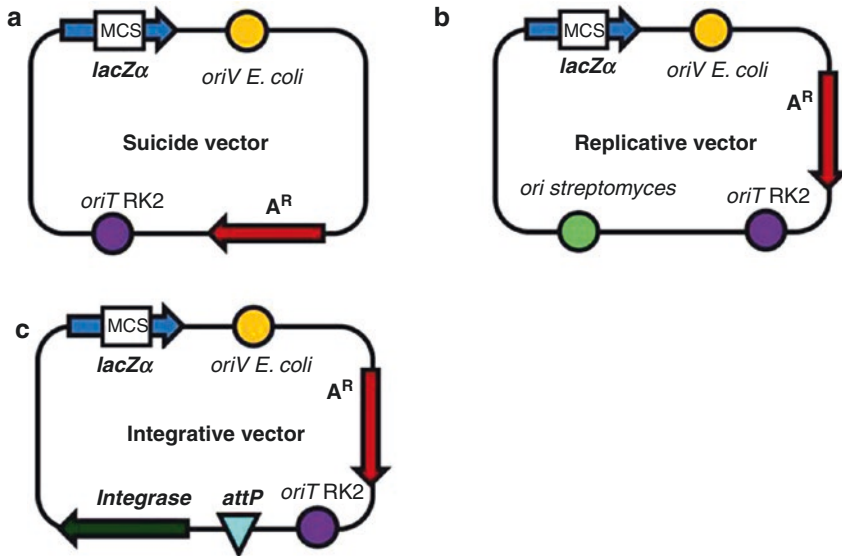
Plasmid	Size, kb	Description	Source
<i>Suicide</i>			
pOJ260	3.5	Am <sup>R</sup> , rep pUC, RK2 <i>oriT</i>	Derivative of pKC787
pKC1138	6.6	Am <sup>R</sup> , xylE, rep pUC, RK2 <i>oriT</i>	Derivative of pOJ260 with the deletion of <i>KpnI</i> to <i>SpeI</i> sites
pKC1132	3.5	Am <sup>R</sup> , rep pUC, RK2 <i>oriT</i>	Derivative of pHJL401
pKC1250	3.8	Sp <sup>R</sup> , rep p15A, RK2 <i>oriT</i>	Derivative of pKC978
pSET151	6.2	Thio <sup>R</sup> , Ap <sup>R</sup> , xylE, rep pUC, RK2 <i>oriT</i>	Derivative of pHJL401
<i>Replicative</i>			
<i>Derivatives of pIJ101, high copy number</i>			
pIJ101	8.83	<i>ori</i> of replication in <i>Streptomyces</i> , <i>tra</i> locus, <i>sti</i> locus, <i>korA</i> repressor, <i>oriT</i> , <i>kilA</i> , <i>kilB</i>	Plasmid from <i>S. lividans</i> ISP5434
pHZ1358	8.26	<i>ori</i> of replication in <i>Streptomyces</i> , <i>tra</i> locus, <i>korA</i> repressor, <i>oriT</i> , <i>kilA</i> , <i>kilB</i>	Derivative of pIJ101
pIJ102	4.0	<i>ori</i> of replication in <i>Streptomyces</i> , <i>sti</i> locus, <i>kilA</i> , <i>kilB</i>	Derivative of pIJ101
pIJ103	3.9	<i>ori</i> of replication in <i>Streptomyces</i> , <i>sti</i> locus, <i>kilA</i> , <i>kilB</i>	Derivative of pIJ101
pIJ104	4.9	<i>ori</i> of replication in <i>Streptomyces</i> , <i>sti</i> locus, <i>kilA</i> , <i>kilB</i>	Derivative of pIJ101
pIJ350	5.0	Thio <sup>R</sup> , <i>ori</i> of replication in <i>Streptomyces</i> , <i>sti</i> locus, <i>kilA</i> , <i>kilB</i>	Derivative of pIJ102
pIJ702	5.8	melC, Thio <sup>R</sup> , <i>ori</i> of replication in <i>Streptomyces</i> , <i>sti</i> locus, <i>kilA</i> , <i>kilB</i>	Derivative of pIJ350
pANT849	5.34	Thio <sup>R</sup> , <i>snpA</i> gene promoter, <i>ori</i> of replication in <i>Streptomyces</i> , <i>sti</i> locus, <i>kilA</i> , <i>kilB</i>	Derivative of pANT42
pSOK101	7.1	<i>ori</i> of replication in <i>E. coli</i> , Am <sup>R</sup> , Thio <sup>R</sup> , <i>oriT</i> RK2, <i>ori</i> pOJ101	Derivative of pWHM3
<i>Medium to low copy number</i>			
pKC1139	6.5	<i>ori</i> pUC, <i>ori</i> pSG5, <i>lacZa</i> , Am <sup>R</sup> , <i>oriT</i> RK2,	Derivative of pOJ260
pKC1218	5.8	<i>ori</i> pUC, <i>ori</i> SCP2*, <i>lacZa</i> , Am <sup>R</sup> , <i>oriT</i> RK2	Derivative of pOJ260
pKC1218E	6.0	<i>ori</i> pUC, <i>ori</i> SCP2*, <i>lacZa</i> , Am <sup>R</sup> , <i>oriT</i> RK2, <i>ermEp</i> *	Derivative of pOJ260
pOJ446	10.4	<i>ori</i> pUC, <i>ori</i> SCP2*, <i>oriT</i> RK2, Am <sup>R</sup> , <i>cos</i> sites (3)	Derivative of pKC505

(continued)



**Table 5.3** (continued)

Plasmid	Size, kb	Description	Source
pGM446	10.3	<i>ori</i> pUC, <i>ori</i> pSG5, Thio <sup>R</sup> , Am <sup>R</sup> , <i>ori</i> T, <i>cos</i> sites (3)	Derivative of pOJ446
<i>Integrative</i>			
pSET152	5.5	<i>ori</i> pUC, $\phi$ C31-based integrative vector, <i>ori</i> T RK2, Am <sup>R</sup> , <i>lacZa</i>	Derivative of pKC912A16
pOJ436	11.1	<i>ori</i> pUC, $\phi$ C31-based integrative vector, <i>ori</i> T RK2, Am <sup>R</sup> , <i>cos</i> sites (3)	Derivative of pKC731
pOJ444	35.3	$\phi$ C31-based integrative vector, <i>ori</i> T RK2, Am <sup>R</sup> , Km <sup>R</sup> , <i>cos</i> sites (3), <i>loxP</i> , <i>PI</i> packing system, <i>PI</i> replicon	Derivative of pNS582tet14AD10
pTO1		<i>ori</i> pBR322, $\phi$ C31-based integrative vector, Ap <sup>R</sup> , Thio <sup>R</sup> , <i>ori</i> RK2	
pTES	5.9	<i>ori</i> ColE1, erythromycin gene resistance promoter ( <i>ermEp</i> ), Am <sup>R</sup> , <i>ori</i> RK2, $\phi$ C31-based integrative vector, <i>loxP</i> sites for excision	Derivative of pSET152
pSTREPTOBAC5	16.0	<i>ori</i> pUC, Am <sup>R</sup> , $\phi$ C31-based integrative vector, <i>ori</i> RK2	Derivative of pBACe3.6
pPAC-S2	22.5	<i>ori</i> pUC, neomycin resistance gene, Thio <sup>R</sup> , <i>sacB</i> , $\phi$ C31-based integrative vector	Derivative of pCYPAC2
pRT801	5.2	$\phi$ BT1-based integrative vector, <i>ori</i> pUC, <i>ori</i> T RK2, Am <sup>R</sup> , <i>lacZa</i>	Derivative of pSET152
pMS81	5.3	$\phi$ BT1-based integrative vector, <i>ori</i> pUC, <i>ori</i> T RK2, Hyg <sup>R</sup> , <i>lacZa</i>	Derivative of pRT801
pMS82	5.3	$\phi$ BT1-based integrative vector, <i>ori</i> pUC, <i>ori</i> T RK2, Hyg <sup>R</sup> , <i>lacZa</i>	Derivative of pRT801
pSBAC	12.0	<i>ori</i> V and <i>ori</i> 2 for replication in <i>E. coli</i> , <i>repE</i> , for copy number regulation; <i>parA</i> , <i>B</i> , <i>C</i> , for partitioning F plasmid DNA, Am <sup>R</sup> , <i>ori</i> RK2, $\phi$ BT1-based integrative vector	Derivative of pCC1BAC
pKT02	6.07	Thio <sup>R</sup> , Ap <sup>R</sup> , <i>ori</i> replication in <i>E. coli</i> $\phi$ BT1-based integrative vector	Derivative of pIC20R
pSOK804	5.3	Am <sup>R</sup> , <i>ori</i> replication in <i>E. coli</i> , <i>ori</i> T RK2, $\phi$ BT1-based integrative vector	Derivative of pKT02
pTOS	5.4	<i>ori</i> ColE1, Am <sup>R</sup> , <i>ori</i> RK2, <i>rox</i> sites for excision, VWB-based integrative vector	Derivative of pSOK804
pSAM	10.92	<i>int</i> and <i>xis</i> genes for integration and excision, <i>rep</i> gene for replication, <i>tra</i> and <i>spd</i> genes for plasmid transfer and spreading	Plasmid from <i>S. ambifaciens</i> ATCC15154
pPM927	13.0	<i>ori</i> pBR322, Sp <sup>R</sup> , Thio <sup>R</sup> , <i>ori</i> T RK2, <i>int</i> and <i>xis</i> genes	Derivative of pSAM
pKU462		<i>ori</i> pMB1, TG1-based integration vector, Km <sup>R</sup>	



**Fig. 5.1** Schematic representation of vectors used in genetics of mycelial *Actinobacteria*. (a) Suicide; (b) replicative; (c) integrative.  $A^R$  antibiotic resistance marker, *lacZα* gene that encodes  $\beta$ -galactosidase, *ori* origin of replication, *oriT* origin of conjugal transfer, MCS multiple cloning sites, *attP* integrase recognition sites

*Actinobacteria* are pOJ260, pSET151, pKC1132, pKC1138 and pKC1250 (Table 5.3) (Bierman et al. 1992; Kieser et al. 2000). These vectors contain the RK2 origin of transfer (Guiney and Jakobson 1983) and, thus, might be transferred into *Actinobacteria* strains via intergeneric conjugation with *E. coli*. They also contain an *E. coli* replication function from pUC (Yanisch-Perron et al. 1985), PA15 (Chang and Cohen 1978) or P1 (Sternberg 1990a, b) and, therefore, might be used for routine cloning in *E. coli*. For this purpose, they contain MCS within the *lacZα* gene that facilitates the easy detection of recombinant clones. Markers for selection in *E. coli* and *Streptomyces* were incorporated into these vectors: pOJ260 (apramycin-resistant gene,  $Am^R$ ), pKC1138 ( $Am^R$ ), pKC1132 ( $Am^R$ ) and pKC1250 (spectinomycin,  $Sp^R$ ). The pSET151 vector contains the thiostrepton resistance gene for selection in *Streptomyces* and ampicillin ( $Ap^R$ ) for *E. coli*. Because these vectors are widely used for gene substitutions via homologous recombination, the *xylE* reporter gene from *Pseudomonas* was incorporated into pSET151 and pKC1138, which facilitates the selection of the clones with the second crossover event. Colonies that contain the integrated vector will produce yellow pigment after the conversion of the colourless substrate catechol into hydroxyumuconic semialdehyde (Ingram et al. 1989), whereas clones that lose the vector backbone, and consequently *xylE*, will stay uncoloured.

There are many replicative plasmid vectors (Fig. 5.1) known and used for Gram-negative bacteria and low GC content Gram-positive bacteria; however, an absolute majority of them cannot be maintained in mycelial *Actinobacteria*, especially *Streptomyces*. Therefore, all of the replicative vectors carry the origins of replication from native plasmids isolated from *Actinobacteria*. There are several low- and high-copy number vectors for these bacteria (Table 5.3). pIJ101 is an autonomous 8.83 kb plasmid from *S. lividans* ISP5434 that exists at 40–300 copies per chromosome, which is the highest natural copy number described so far for *Actinobacteria*. It contains a *Streptomyces* origin of replication; the *tra* locus, which is essential for plasmid transfer between *Streptomyces*; the *sti* locus, which confers strong incompatibility (causes the accumulation of single-strand plasmids in the host); the *korA*-encoding repressor for *tra*; *clt*-*cis*-acting transfer function (probably *oriT*); *kilA*, which is the promoter and aminoterminal region of *tra*; and *kilB*, which is the lethal gene when expressed in the absence of *korB* (a regulator for *kilB*) (Kieser et al. 2000). The deletion of the 574 bp DNA region containing the *sti* locus from pIJ101 yielded a highly unstable plasmid pHZ1358, which is widely used for targeted gene disruption and replacement experiments in many *Streptomyces*, as well as *Actinoplanes* hosts (Sun et al. 2002; Enríquez et al. 2006; Truman et al. 2008). Several derivatives of pIJ101 lacking the region for conjugation transfer, pIJ102 (4.0 kb), pIJ103 (3.9 kb) and pIJ104 (4.9 kb), have been described. These plasmids naturally occur in the *S. lividans* strain and have been used for the construction of the first generation of *Actinobacteria* replicative vectors. For example, pIJ350 is a derivative of pIJ102 that contains the thiostrepton resistance marker obtained from *S. azureus* (Kieser et al. 1982). Based on pIJ350, the pIJ702 vector, one of the most widely used derivatives of the pIJ plasmids family, was generated after the incorporation of the tyrosinase gene (*mel*) from *S. antibioticus* (Katz et al. 1983). The regulatory region of the *mel* gene has three unique sites for the *Sst*I, *Bgl*II and *Sph*I restriction endonucleases, which permits the easy recognition of colonies containing the insertion of the DNA of interest and is thus unable to convert tyrosine into the black pigment melanin. The main drawback of the pIJ vectors described above is that they do not contain the *E. coli* origin of replication; consequently, manipulations in this strain are impossible, and all constructions should be performed in *S. lividans*, which is very complicated. Another disadvantage is that they can be transferred into *Actinobacteria* by protoplast transformation (the efficiency can reach up to  $5 \times 10^6$  transformants per mg of DNA), which is a laborious procedure that very often has not been established for non-model strains. Despite these drawbacks, the pIJ702 vector was successfully utilised in many *Streptomyces* strains and *A. orientalis* and *Thermomonospora fusca* (Matsushima et al. 1987; Pidcock et al. 1985). Given the high copy number of this plasmid, numerous genes were overexpressed in *S. lividans* and some other actinobacterial strains, which provided high yields of the product of interest, for instance, xylanase, which is an enzyme that is useful in the degradation of some industrial and agricultural wastes (Iwasaki et al. 1986; Mondou et al. 1986).

Using the pIJ101 origin of replication, the high-copy number expression vector pANT849 was constructed (Table 5.3). pANT849 contains the thiostrepton resistance gene and the *snpA* protease gene promoter that is regulated by SnpR

(Lampel et al. 1992). It was shown that the expression of the reporter protein from this promoter was 50 times higher than that from the *melC1* promoter. These vectors were used for the expression of genes in *S. lividans* (Dickens and Strohl 1996; Dickens et al. 1996). Another vector with the *ori* pIJ101 is pSOK101, which also contains the *E. coli* origin of replication and might be used for gene cloning in *E. coli* (Zotchev et al. 2000). This vector also has apramycin and thiostrepton resistance genes and the RK2 origin of conjugal transfer, *oriT*. It was applied for the gene expression in *Streptomyces*; however, this multicopy origin appeared to be non-functional in *Actinoplanes* (Horbal et al. 2012). Four other widely used vectors with the *ori* pIJ101 replicon are pUWL218, pUWL219, pUWL-SK and pUWL-KS (Wehmeier 1995). They contain the ampicillin and thiostrepton resistance genes for selection in *E. coli* and *Streptomyces*, respectively, the ColE1 origin of replication in *E. coli*, the *lacZ* gene for the blue-white selection of recombinant plasmids and MCS with a number of unique cloning sites.

The most widely used medium- to low-copy number replicative vectors are pKC1139, pKC1218, pKC1218E and pOJ446 (Table 5.3). The pKC1139 vector is a derivative of pOJ260 (Bierman et al. 1992). It was obtained via the cloning of the temperature-sensitive replicon *ori* pSG5 of *S. ghanaensis* from pSW344E. This vector contains a pUC origin of replication in *E. coli*, *lacZ $\alpha$*  with multiple cloning sites, an apramycin resistance gene (*aac(3)IV*) and the RK2 origin of conjugal transfer (*oriT*). It occurs at a copy number of 20–50. Due to the presence of the thermo-sensitive *ori* pSG5, the replication of the plasmid is impaired at temperatures >34°C. This vector was efficiently used for transposon delivery, the inactivation of genes via homologous recombination, complementation and gene overexpression (Ikeda et al. 1993; Horbal et al. 2010, 2014a; Ostash et al. 2009, 2015; Li et al. 2010; Myronovskyy et al. 2009). The main drawback of this vector is that *ori* pSG5 is not functional in some mycelial *Actinobacteria*; for instance, conjugal transfer of this vector was not possible for the known bottromycin producer *S. sp.* BC16019 (unpublished).

Plasmid pKC1218 was constructed via the insertion of the SCP2\* replicon into pOJ260 (Larson and Hershberger 1984, 1986). It contains an *E. coli* origin of replication, the *lacZ $\alpha$*  gene, multiple cloning sites, the apramycin resistance gene marker and the RK2 origin of conjugal transfer *oriT* (Bierman et al. 1992). Thus, this plasmid can be transferred into *Actinobacteria* via conjugation. The derivative of pKC1218 was obtained via the insertion of a strong erythromycin gene resistance promoter (*ermEp*<sup>\*</sup>) into the MCS region, which resulted in pKC1218E. However, one should consider the absence of the ribosomal binding site (RBS) after the promoter during the construction design. This vector was efficiently used in various *Streptomyces* strains (Myronovskyy et al. 2009) and in *Actinoplanes* (Horbal et al. 2012). The cosmid vector pOJ446 contains the SCP2\* replicon, the apramycin resistance gene, the RK2 origin of conjugal transfer *oriT* and three *cos* sites and can accept DNA insertions up to 45 kb. This vector has been widely used for the cloning and expression of gene clusters in *Streptomyces* (Cone et al. 1998; Gould et al. 1998). The derivative of pOJ446, pGM446, was used for expression in *Micromonospora* (Rose and Steinbüchel 2002). Unlike pOJ446, it contains the pSG5 origin of replication and the thiostrepton resistance gene.

The main drawback of the above-mentioned replicative vectors is that they require antibiotic selection to be stably maintained in the host cell. This is not feasible for recombinant strains cultivated under industrial conditions. Therefore, there is a need for integrative vectors that site-specifically integrate into the chromosome and do not require selective pressure for maintenance in the cell. Site-specific integration has clear advantages for the integration via homologous recombination because it does not depend on the length of the homology arms and is much more efficient and stable. There are numerous integrative vectors developed for mycelial *Actinobacteria*, which utilise various integration phage systems (Table 5.3). These systems originate from temperate bacteriophages  $\phi$ C31, BT1, VWB, TG1 and  $\mu$ 1/6 (Lomovskaya et al. 1971; Gregory et al. 2003; Anné et al. 1984; Farkasovská et al. 2007; Myronovskiy and Luzhetskyy 2013; Baltz 2012). They utilise an integrase protein that belongs to the serine or tyrosine family of recombinases and catalyse recombination between *attP* (located on the vector) and *attB* (located on the chromosome of bacteria) sites, resulting in the integration of the DNA of interest into the chromosome. The number of integrations into a chromosome depends on the quantity of *attB* sites in the latter.

Vectors that utilise the integrative systems from the  $\phi$ C31 bacteriophage are the most widely used in the genetics of mycelial *Actinobacteria*. These include pSET152, pOJ436 and pOJ444 (Table 5.3). The pSET152 plasmid and the pOJ436 cosmid contain MCS within the *lacZ $\alpha$*  gene and the pUC origin of replication to enable cloning in *E. coli*, Am<sup>R</sup> and the RK2 origin of transfer *oriT*. In addition, the pOJ436 vector contains three *cos* sites for in vitro packaging into lambda phage (Bierman et al. 1992; Kieser et al. 2000). This cosmid can be used for cloning DNA fragments up to 45 kb. However, in the case of using the cosmid for the in vitro packaging into the lambda phage head, the size of the insertion should not exceed 35 kb. The pOJ444 vector is designed to use a P1 packing system and thus it contains a P1 packing site (*pac*) and two directly oriented *loxP* sites to cyclise the packed DNA once it is injected into *E. coli* expressing Cre recombinase (Nagy 2000). In addition, it carries the neomycin resistance gene (*neo*) for selection, the  $\phi$ C31 integration system, the P1 replicon for maintenance in *E. coli* and the RK2 origin of transfer. It was shown that the pOJ444 system can stably maintain up to 100 kb fragments (Sternberg 1990a, b).

It is worth noting that pTES is another integrative vector for marker-free expression in *Actinomycetes*. It contains the ColE1 origin of replication in *E. coli*, the erythromycin resistance gene promoter (*ermEp*) for gene expression, Am<sup>R</sup> for selection, the  $\phi$ C31 integrase gene and the *attP* site and the RK2 origin of transfer. The integrase gene, the *attP* site and MCS are surrounded by the *loxP* sites. After the pTES plasmid with a gene of interest is integrated into a chromosome, its backbone containing *ori* ColE1, Am<sup>R</sup>, *oriT* and integrase can be removed after the expression of Cre (Herrmann et al. 2012). The vectors described above were successfully used for expression, not only in *Streptomyces* but also in *Actinoplanes*, *Actinomadura*, *Arthrobacter*, *Micromonospora*, *Nocardia*, *Rhodococcus* and *Nonomuraea* (Voeykova et al. 1998; Stinchi et al. 2003; Li et al. 2003; Ha et al. 2008; Horbal et al. 2012; Baltz 2012), which proves their wide utility.

The pRT801 (Baltz 2012), pMS81 and pMS82 (Gregory et al. 2003) integrative vectors utilise an alternative integration system from bacteriophage  $\phi$ BT1. The number of integrations into the genome depends on the quantity of the respective *attB* site in the chromosome. These vectors are a good alternative for the  $\phi$ C31-based vectors, in the case if  $\phi$ C31-*attB* sites are not present in the genome. The pRT801 vector is a derivative of pSET152, in which the *attP/int*- $\phi$ C31 locus was substituted with the *attP/int*- $\phi$ BT1 fragment. In addition, this vector contains the  $\text{Am}^R$  gene, the origin of conjugal transfer, MCS and the origin of replication in *E. coli*. The pMS81 and pMS82 vectors are derivatives of pRT801 that contain the hygromycin resistance gene instead of apramycin. The utility of the described vector molecules was previously shown in various *Streptomyces* strains: *S. fradiae*, *S. avermitilis*, *S. venezuelae*, *S. ghanaensis* and *S. nogalater*.

The pTOS (Herrmann et al. 2012), pKT02 (Van Mellaert et al. 1998) and pSOK804 (Sekurova et al. 2004) vectors utilise an integration system that originates from the VWB bacteriophage. The VWB integrase belongs to the tyrosine recombinase family. The pKT02 vector contains the backbone of the pIC20R and the thiostrepton resistance gene for selection in *Streptomyces*. However, this plasmid does not contain the origin of conjugal transfer; therefore, it can be delivered into *Streptomyces* cells only by protoplast transformation. The efficiency of the latter procedure is much lower in comparison with conjugation. The pSOK804 vector was constructed via the ligation of the 2.3 kb *SphI/HindIII* fragment from pKT02 to a 3.0 kb *SphI/HindIII* fragment of pSET152. Thus, it contains an origin of replication in *E. coli*, an origin of transfer that makes it more convenient than pKT02 and the  $\text{Am}^R$  gene.

Recently, a marker-free expression integrative vector, pTOS, was constructed (Herrmann et al. 2012). It harbours the *colE1* origin of replication in *E. coli*, the VWB *int-attP* system, the RK2 origin of transfer, the *rox* sites and the  $\text{Am}^R$  gene. After the vector with the gene of interest is integrated into the chromosome of the strain, its backbone containing the resistance marker can be deleted upon the expression of Dre recombinase (Herrmann et al. 2012).

One more alternative is pSAM2, which is an integrative vector found in *S. ambofaciens* ATCC15154 (Kuhstoss et al. 1989). It contains the *int* gene, whose product resembles bacteriophages recombinases, the *xis* gene involved in plasmid excision, the *attP* site for integration, the *rep* gene for replication and the *tra* and *spd* genes that are responsible for plasmid transfer and spreading (Sezonov et al. 1995). The pPM927 vector is a derivative of the pSAM2 natural vector. It harbours the *E. coli* pBR329 replicon, the thiostrepton and spectinomycin resistance genes, an origin of transfer, the *int* and *xis* genes from pSAM2 and the thiostrepton-inducible promoter for gene expression (Smokvina et al. 1990). These vectors were successfully transferred into the following *Streptomyces* strains: *S. ambofaciens*, *S. lividans*, *S. toyo-caensis*, *S. hygroscopicus*, *S. avermitilis*, *S. aureofaciens*, *S. coelicolor* and *S. fradiae* (Wang et al. 2009; Novakova et al. 2010; Zhao et al. 2010a; Liu et al. 2010).

The pKU462 integrative vector utilises the integration system from the temperate bacteriophage TG1. It contains the pMB1 origin of replication in *E. coli*, a kanamycin resistance gene for selection, the *int-attP* system from TG1 and an origin of

conjugal transfer (Morita et al. 2009). It was previously used for the DNA integration in *S. avermitilis* (Jiang et al. 2009).

Plasmid and cosmid vectors have a loading capacity of 15 and 45 kb, respectively. However, the size of many biosynthetic gene clusters for natural products is larger than the average insert size of a cosmid vector. Thus, to overcome this problem, bacterial artificial chromosomes (BACs) and P1-derived artificial chromosomes (PACs), which can carry large DNA inserts of 100–300 kb, have been used for mycelial *Actinobacteria* including pPAC-S2 (Sosio et al. 2000) and pSTREPTOBAC5 (Miao et al. 2005). They are replicative in *E. coli* and integrative in *Streptomyces*. The integration at the *attB* site on the chromosome of *Streptomyces* is mediated by  $\phi$ C31. pSTREPTOBAC5 is based on the *E. coli* F factor (Alduina and Gallo 2012). It contains the RK2 origin of conjugal transfer, the Am<sup>R</sup> gene and the  $\phi$ C31-*attP* integration system. The pPAC-S2 harbours an origin of replication in *E. coli*, neomycin and thiostrepton resistance genes, the *sacB* gene that codes for levansucrase and converts sucrose to levan that accumulates in the cell periplasm and is toxic for the cell (Pelicic et al. 1996) and the  $\phi$ C31-*attP* integration system. These BACs were successfully used for the expression of different gene clusters (iso-migrastatin, daptomycin, meridamycin and tautomycetin) in a broad range of expression hosts: *S. albus*, *S. avermitilis*, *S. coelicolor*, *S. lividans* and *Streptomyces* sp. CK4412 (Komatsu et al. 2010; Tetzlav et al. 2006; Miao et al. 2005; Liu et al. 2009; Penn et al. 2006).

Recently, the pSBAC vector utilising the  $\phi$ BT1-*attP* integration system was created (Liu et al. 2009). It contains *oriV* and *ori2* for replication in *E. coli*; the *repE* gene for replication and regulation of its copy number; and *parA*, *B* and *C* for partition to daughter cells during division and to ensure the stable maintenance of BAC, Am<sup>R</sup>, the RK2 origin of transfer and the  $\phi$ BT1-*attP* integration system. This BAC was previously utilised for the heterologous expression of tautomycin (Nah et al. 2015) and meridamycin gene clusters (Liu et al. 2009).

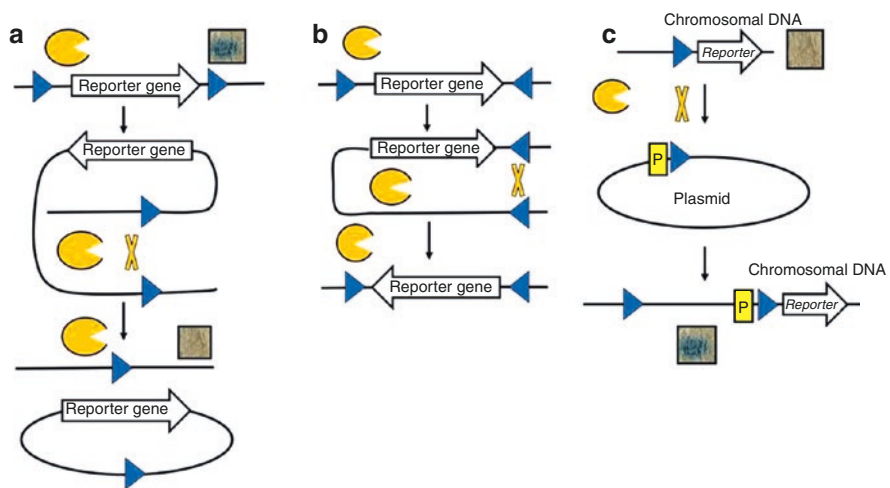
---

## 5.5 Genetic Toolkit for the Manipulation of Mycelial *Actinobacteria*

At least one-third of the putative ORFs in the genomes of *Actinobacteria* have no assigned function, and their role is unknown. Currently, our understanding of their function and interaction is far from complete (i.e. it is in the “infant” stage). Different molecular genetic tools were developed to study gene functions, to perform genome rearrangements in *Actinobacteria* and to activate silent gene clusters. Here, we present some of the recently developed techniques. For more detailed information, we refer the reader to several reviews that provide comprehensive insights (Herrmann et al. 2012; Baltz 2012; Myronovskiy et al. 2013; Bilyk and Luzhetskyy 2016). Site-specific recombination techniques (SSR); marker-free excision systems; programmed endonucleases, such as Cas9; transposon mutagenesis; and various controlling elements have been developed for mycelial *Actinobacteria*.

### 5.5.1 Site-Specific Recombination Tools

Site-specific genome recombination tools have been described for various bacteria, including Gram-positive and Gram-negative bacteria, and they represent a powerful toolkit for genome manipulations. The most widely used enzymes are the Cre recombinase from the P1 phage, the FLP recombinase from *Saccharomyces cerevisiae* and the Dre recombinase from D6 phage. All three belong to a class of tyrosine recombinases and share a common reaction mechanism of recombination that involves strand cleavage, exchange and ligation (Sadowski 1995). In addition, they recognise short target sequences in the genome and perform bidirectional recombination, which results in the excision, inversion or integration of the DNA region depending on the orientation of the target recognition sites (Fig. 5.2). After the DNA excision, one recognition site remains in the genome that precludes the iterative use of these systems due to possible unwanted genome rearrangements. The successful application of these recombinases for genome engineering in different organisms including pro- and eukaryotes is due to their simplicity and high efficiency. All three enzymes do not require any cofactors for the reaction, and their target sites are well established and small enough to be easily introduced into any region of interest. Currently, the main applications of SSR technologies are for the construction of unmarked mutants (Suzuki et al. 2005), the marker-free expression of foreign genes (Schweizer 2003), the deletion of large DNA segments (Suzuki et al. 2005), the targeting of heterologous DNA into the chromosome (Kuhstoss et al. 1991) and the in vivo cloning of DNA regions (Schweizer 2003).



**Fig. 5.2** Schematic depiction of reactions catalysed by recombinases. (a) Excision; (b) inversion; (c) integration. Recognition sites are denoted as *blue triangles*



One of the first and most widely used SSRs is Cre. It recombines DNA at two 34 bp recognition sites named *loxP* (locus of crossover (x) in P1) (Hoess et al. 1982). The *loxP* sequence consists of two 13 bp inverted repeats linked together by an 8 bp internal region. The first report of the application of Cre recombinase in *Streptomyces* occurred in 2006 from the laboratory of M. Smith (Khodakaramian et al. 2006). The efficiency of the resistance marker excision was 60–90%. However, this system has not acquired wide applicability, which is probably because of the inconvenience of the method for the *cre* gene delivery. Afterwards, the codon-optimised version of the *cre* gene was created and efficiently utilised for marker removal in various *Actinobacteria* including *Streptomyces*, *Micromonospora*, *Kitasatospora* and *Saccharothrix* (Fedoryshyn et al. 2008a; Herrmann et al. 2012; Siegl and Luzhetskyy 2012; Lopatniuk et al. 2015). The efficiency of marker removal was close to 100% in all of the tested strains. Recently, it was shown that the Cre/*loxP* system can be used to perform large genome deletions up to 1.5 Mb (Komatsu et al. 2010). With the aim of the iterative use of Cre for marker excision and to minimise genetic instability, different heterotypic *lox* sites containing mutations within the inverted repeats (*loxLE* and *loxRE*) were designed and used in plants and mammals (Branda and Dymecki 2004; Leibig et al. 2008). However, we showed that Cre recognises the double-mutated site at a very high frequency in *Actinomycetes*. Thus, the risk of undesired genome rearrangements is very high if Cre is iteratively used in combination with *loxLE* and *loxRE* (Herrmann et al. 2012).

Flp is an alternative tyrosine recombinase that recognises defined 34 bp target sites named FRT (Flp recombinase recognition target). They consist of two 13 bp palindromic sequences separated by an 8 bp spacer region. The efficient expression of the *flp* synthetic gene with GC content optimised for *Streptomyces* was recently reported in different *Actinobacteria*, namely, *S. coelicolor* M145, *S. lividans* TK24 and *Saccharothrix espanaensis* (Fedoryshyn et al. 2008b; Herrmann et al. 2012). However, the frequency of *frt*-flanked resistance gene excision from the chromosome of actinomycetes ranged from 10 to 40%, which is significantly lower in comparison with Cre.

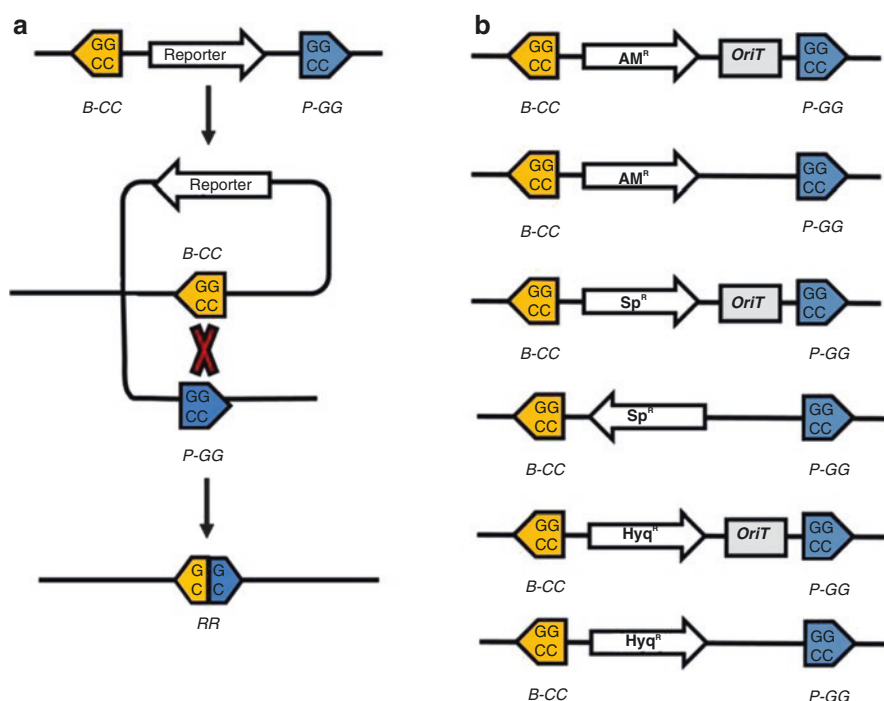
One more SSR recently established for use in *Actinobacteria* is Dre. Dre catalyses recombination between two 32 bp *rox* sites (region of crossover (X-over)) (Sauer and McDermott 2004). A functional expression of the synthetic *dre* gene with the codon usage optimised for *Streptomyces* was performed in different *Actinobacteria*, namely, the *Saccharothrix*, *Streptomyces* and *Micromonospora* genera (Herrmann et al. 2012). The important feature of the above-mentioned recombinases is their heterospecificity: Cre does not catalyse recombination at *rox* and *frt* sites, FLP does not catalyse recombination at *lox* and *rox* sites, and finally, Dre does not catalyse recombination at *lox* and *frt* sites. Thus, together, they represent a compatible SSR toolkit and might be used simultaneously in the genetic background of the same strain for different purposes.

Another marker excision system utilises the products of the *int* and *xis* genes from the pSAM2 vector and catalyses marker removal from the genome via recombination between the *attL* and *attR* sites. Several cassettes containing an antibiotic resistance marker surrounded with the *attL* and *attR* sites have been constructed and

efficiently utilised for *Streptomyces* (Raynal et al. 2006). In summary, Cre, Flp, Dre and Int/Xis SSR systems might be used for the deletion of at least four antibiotic markers in the genetic background of a single strain.

### 5.5.2 Iterative Marker-Free Excision System

All of the above-described marker-free excision recombinases are susceptible to the same problem: they cannot be used iteratively because they leave an active recognition site in the genome. However, projects on strain improvement require the manipulation of dozens or hundreds of loci that will lead to genome minimization, the improvement of precursor supply and cluster activation. Thus, there is a need for a system that will not leave an active recognition site on the chromosome and might thus be used iteratively for genome editing purposes. This type of system was recently created. It utilises  $\phi$ C31 integrase and its mutated *att* sites and is called an iterative marker-free excision system (IMES) (Myronovskiy et al. 2014). The system can efficiently delete DNA regions that are located in between the inversely oriented B-CC and P-GG sites (Fig. 5.3). These sites are derivatives of *attB* and *attP*



**Fig. 5.3** Schematics of fragment excision using recombinase and mutant attachment sites. (a) The *phiC31* integrase recombinates with inversely oriented B-CC and P-GG sites and leads to the formation of an RR site. (b) Antibiotic resistance cassettes for DNA deletion experiments

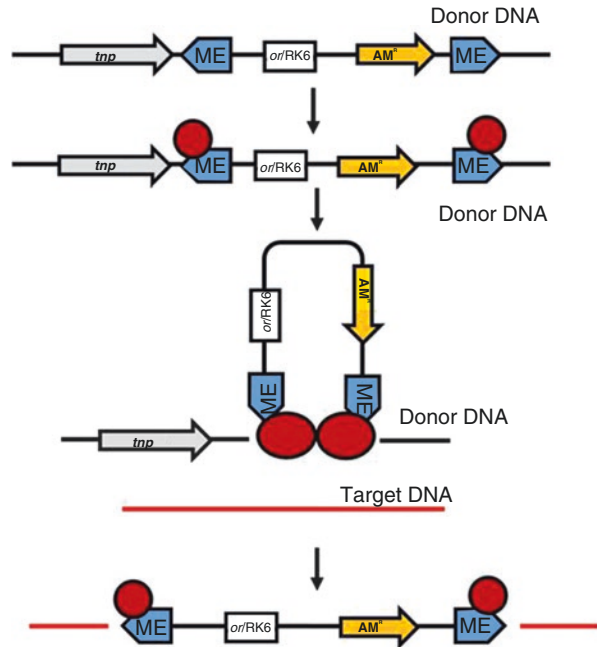
by the substitution of the central core TT dinucleotide with CC and GG. The RR site that evolves as a result of deletion is a joining product of the right shoulders of B-CC and P-GG. It was reported that RR sites do not recombine between one another, and the recombination efficiency between RR and P-GG or RR and B-CC is lower than 0.1 and 1%, respectively. Therefore, IMES might be used for the editing of multiple genomes without the risk of unwanted genome perturbations. Several cassettes carrying apramycin, spectinomycin or hygromycin resistance genes surrounded with P-GG and B-CC sites were created and successfully applied for gene and DNA fragment deletions (Fig. 5.3). One siderophore cluster and two terpenoid clusters that have a size of less than 10 kb, as well as one non-ribosomal peptide gene cluster whose size exceeds 60 kb, were easily deleted using this system from the chromosome of *S. albus* J1074 (Myronovskiy et al. 2014). The efficiency of even a large fragment excision is 100%. In general, this system is easier to use than *Cre/loxP* because the deletion of a DNA fragment of interest might be performed in two steps, and there is no need for additional vectors for recombinase expression because all of the components of the system are located *in cis*.

### 5.5.3 Transposon Mutagenesis in Mycelial Actinobacteria

The huge amount of genetic information that results from next-generation genome sequencing programmes requires methods that will provide the opportunity (relatively quickly) to identify the role of the thousands of genes in a microbial life cycle. Transposon mutagenesis is a valuable tool for deciphering gene function and the genetic analysis of strains, generating gene–operon fusions to a reporter, providing physical or genetic landmarks for the cloning of adjacent DNAs and locating primer binding sites for DNA sequence analysis (Damasceno et al. 2010; Petzke and Luzhetskyy 2009; Weaden and Dyson 1998). Transposon mutagenesis is widely used for both Gram-positive and Gram-negative bacteria (Gehring et al. 2000; Goryshin et al. 2000; Grabher and Wittbrodt 2008).

Several attempts were made to establish a transposon mutagenesis technique for mycelial *Actinobacteria*. One of the first was the Tn4556 transposon that belongs to the Tn3 family and was originally isolated from *Streptomyces fradiae*. Derivatives of this transposon, Tn4560 and Tn4563 (Chung 1987; Schauer et al. 1991), with viomycin and lincomycin resistance genes, respectively, were created and used for *in vivo* mutagenesis in *S. coelicolor* and *S. avermitilis*. However, their random transposition occurs only at temperatures of 37°C or higher (Ikeda et al. 1993). IS493 (a class I insertion sequence) found in *S. lividans* and its derivative Tn5096 containing apramycin resistance gene *aac(3)IV* were developed for mutagenesis in *Streptomyces* spp.; however, they have a strong insertion bias into DNA regions with low G/C content (Solenberg and Baltz 1991). A derivative of the Tn5 transposon, Tn5493, was applied for transposon mutagenesis in *S. lividans*; however, its efficiency in other *Streptomyces* was very low (Volf and Altenbuchner 1997). An improved version of the Tn5 transposon was successfully developed for *Actinobacteria* (Petzke and Luzhetskyy 2009). This version of the transposon contains optimised

**Fig. 5.4** Schematic representation of transposon integration into the chromosome using copy and paste mechanism



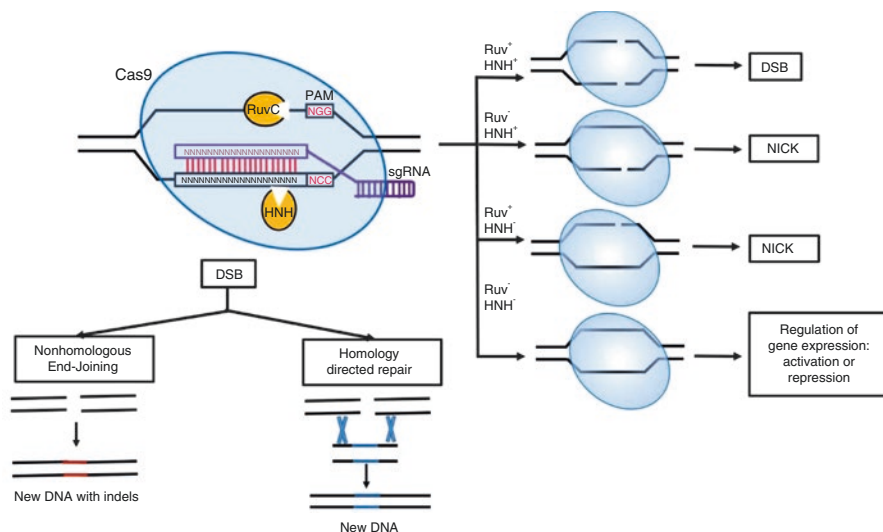
Tn5 mosaic end sequences (ME) and the GC-rich synthetic *tnp(a)* gene that encodes a hyperactive transposase, which binds more efficiently to the transposon ends and performs transposition using a “cut and paste” mechanism (Steiniger et al. 2006). An apramycin resistance gene and the R6K origin of replication, which allows the easy cloning of the insertion site directly from the chromosome, are located in between the ME sequences (Fig. 5.4). This system was successfully applied to several *Streptomyces* strains, namely, *S. coelicolor*, *S. lividans*, *S. albus*, *S. globisporus* and *S. fradiae* (Petzke and Luzhetskyy 2009; Horbal et al. 2013a, b). The insertion frequency for the Tn5 derivative is 98% of the transformed *S. coelicolor* cells. A minor drawback of this system is that Tn5 transposon insertions are slightly biased to GC-rich sequences (Fernández-Martínez et al. 2011). To overcome gaps in chromosome coverage attributed to insertion site biases, another system based on the mariner *himar1* transposon, which requires the presence of a TA dinucleotide for insertion, might be used. This system utilises the synthetic GC-rich *himar1* transposase gene and inverted terminal repeats (ITRs). Several vectors, pHAH, pHTM, pHSM and pHAM, containing all of the elements that are necessary for transposition, were created (Bilyk et al. 2013). First, three plasmids contain the temperature-sensitive replicon *ori* pSG5, and they can thus be easily lost after mutagenesis in non-permissive conditions. The pHAM vector does not contain the origin of replication for *Streptomyces*; therefore, all of the colonies obtained after conjugation are already transposon mutants. The advantage of this system is that there is no need to get rid of the plasmid. In addition, mini-transposons are equipped with the *loxP* or *rox* sites that allow the excision of the resistance marker using Cre or Dre

recombinases and their further utilisation in the same genetic background. The *Himar1* transposon was successfully applied for transposon mutagenesis in *S. coelicolor* and *S. albus* (Bilyk et al. 2013).

Recently, the mini-transposon encoding apramycin resistance gene *aac(3)IV*, within its inverted repeats (IRs) boundaries and utilising the IS204 transposase from *Nocardia asteroides* YP21, was adopted for efficient mutagenesis in *Streptomyces* (Zhang et al. 2012). All of the elements necessary for transposition are located on the pDZY101 plasmid that has only an *E. coli* origin of replication, and after conjugal transfer, all of the colonies are transposon mutants. This system is characterised by the random distribution of insertions and genetic stability.

### 5.5.4 Programmed Endonucleases, Cas9

Conventional gene editing in mycelial *Actinobacteria* is based on homologous recombination (HR) and utilises suicide or replicative vectors. However, in most cases, this is a cumbersome and time-consuming procedure because the efficiency of HR is rather low, depends on the length of the homology arms and varies from strain to strain. The efficacy of HR might be improved via the introduction of double-strand DNA breaks (DSBs) into the DNA region of interest. DSBs can be repaired in two ways. In the presence of the homology template, the ends can be efficiently joined by homologous double-crossover recombination (Fig. 5.5). If there is no homology template available, then DSBs can be repaired via non-homologous end joining (NHEJ) (Fig. 5.5) (Pastwa and Błasiak 2003). This is a



**Fig. 5.5** Various CRISPR-Cas9 applications for genome editing. *RuvC* and *HNH* nuclease domains, *DSB* double-strand DNA break

highly error-prone process that leads to indels (insertion and deletions) and might thus be used for gene disruption.

There are several known mega-endonucleases that can introduce DSB into DNA, and they are *SceI* and *DmoI*. The former was adopted for use in *Streptomyces* (Siegl et al. 2010). However, the main drawback of *SceI* and *DmoI* is that they are sequence dependent; they recognise an 18 bp specific sequence and then introduce a DSB. Therefore, to perform a DSB using *SceI*, there is first the need to introduce its recognition site into the region of interest, which is not convenient. Consequently, there was a need for programmed endonucleases that can target any region of interest on the chromosome. There are several programmed endonucleases including transcription activator-like effector nucleases (TALENs), zinc finger proteins and CRISPR-Cas9 that were developed for prokaryotes, mammals and yeast (Boissel et al. 2014; Porteus and Carroll 2005; Kennedy and Cullen 2015). Currently, the most widely used and popular is the CRISPR-Cas9 system due to its high efficacy, simplicity in use and programming. Recently, this system was adopted for *Streptomyces* as well (Cobb et al. 2015; Huang et al. 2015; Tong et al. 2015; Zeng et al. 2015). It utilises the Cas9 protein from *Streptococcus pyogenes*. The CRISPR-Cas9 system requires three components to perform DSBs in DNA. These are the Cas9 protein that contains two nuclease domains, CRISPR RNA (crRNA) that contains the target sequence (an average of 20 bp long) and is fused to tracrRNA that is always the same and is needed to form a complex with the Cas9 protein and a protospacer adjacent motif (PAM) NGG (where N is any nucleotide) that should be located adjacent to the 3'-end of target sequence on chromosomal DNA (Fig. 5.5). The CRISPR-Cas9 system that utilises NHEJ for genome editing also contains the LigD protein that is an ATP-dependent DNA ligase (Pastwa and Błasiak 2003). Three different vectors with the CRISPR-Cas9 system were developed and applied for rational genome editing in *S. coelicolor*, *S. lividans*, *S. pristinaespiralis* and *S. viridochromogenes*. All of the systems perform gene or cluster deletions with 70–100% frequency in the presence of homology templates. The simultaneous targeting of several genes also proved to be efficient (Cobb et al. 2015; Huang et al. 2015). In the absence of a template for homology-directed repair, the DNA region of interest is repaired via NHEJ that leads to a library of mutants with deletions of variable size around the targeted sequence (Fig. 5.5) (Tong et al. 2015). Furthermore, the efficiency is lower and strongly depends on the sequence of crRNA.

The main drawback of the CRISPR-Cas9 editing tool, not only in *Streptomyces* but also in *E. coli*, yeast and mammals, is a relatively high level of off-target effects. Based on a catalytically dead variant of Cas9, a system named CRISPRi was constructed for the precise and reversible control of gene expression (Fig. 5.5) (Tong et al. 2015). In summary, RNA-guided DNA editing technology CRISPRs/Cas9 might be applied to introduce double-strand breaks into genomes and to direct subsequent site-specific insertions/deletions or the replacement of genetic material with high efficiency and relative ease in various *Streptomyces*. This system opens new horizons for rational genome engineering and strain improvement in *Actinobacteria*.

### 5.5.5 Controlling Elements for Transcription Regulation

Genetic information in the cell is transferred from DNA to RNA and to proteins via transcription and translation processes, respectively. Many structural elements, namely, promoters, ribosomal binding sites (RBSs), terminators and 5'- and 3'-untranslated regions (UTRs), influence the efficacy of these processes. In addition, a myriad of regulatory proteins and small non-coding RNAs (e.g. riboswitches and ribozymes) govern the expression of a gene. Thus, a precise understanding of the regulation of gene expression on the above-mentioned levels and the interaction of regulatory genetic elements is needed because this information will pave the way for the rational re-factoring of regulatory networks and secondary metabolite gene clusters with the aim of strain improvement and increased metabolite production. Regulation of bacterial gene expression on the level of transcription is the most relevant. Many efforts were made to engineer promoters that are able to control gene expression. Such promoters are supposed to trigger the expression of a variety of biosynthetic gene clusters unless they are silent under laboratory conditions. Usually, such clusters are organised into operons that control expression of genes to various levels and thus provide a balanced expression of different genes. Therefore, there is a need in the library of promoters with different strengths to fine-tune the expression of genes in clusters.

The transcription of a gene is performed by an RNA polymerase holoenzyme that contains five subunits, which constitute the core enzyme plus a sigma subunit that is responsible for the recognition and binding to the respective promoter (Murakami and Darst 2003). Different sigma subunits bind to corresponding promoters and regulate their activity. There are 65 sigma factors in *S. coelicolor*, including housekeeping *hrdB*, which suggests that they play an important role in the regulation of gene expression. An analysis and comparison of 139 putative promoter sequences in *Streptomyces* revealed that at least 29 fall into a group and are similar to those recognised by eubacterial RNA polymerases containing  $\sigma^{70}$ -like subunits because they contain the -35 hexamer (TTGACA) and the -10 hexamer (TATAAT), and the -10 and -35 hexamers of these promoters are 16–18 nucleotides apart. Some of them, such as SEP2 (Jaurin and Cohen 1985), SEP3 (Jaurin and Cohen 1985), SEP6 (Jaurin and Cohen 1985), SEP8 (Forsman and Jaurin 1987) and pIJIOIA-p (Buttner and Brown 1987), were shown to be functional in *E. coli* (Strohl 1992). The others contain a wide diversity of sequences. Some of them have similarities in the -10 and -35 regions. The main features of these promoters are a very high GC content in comparison with *E. coli* promoters (57–62% versus 43%). In addition, the distance between the -10 and -35 regions is not necessarily in the range of 16–18 nucleotides. Thus, they are not expected to be functional in *E. coli* (e.g. *ermEp*) (Strohl 1992). Therefore, few heterologous promoters from other bacteria will be functional in mycelial *Actinobacteria*.

One of the first, most widely used and well-described constitutive promoters for *Actinobacteria* was the *ermEp* of the erythromycin resistance gene from *Sacch. erythraea* (Bibb et al. 1985). The region upstream of the erythromycin resistance gene contains two promoters: *ermEp1* and *ermEp2*. Both promoters show

considerable similarity to the  $-10$  sequence of the consensus prokaryotic promoter, whereas the  $-35$  sequence shows greater variability. The spacing between the  $-10$  and  $-35$  regions of *ermEp2* is close to the optimal distance (17 bp); however, the distance in *ermEp1* is 14 bp. The GC composition is 62% for *ermEp1* and is 65% for *ermEp2*. Based on *ermEp1*, an enhanced version of the erythromycin promoter (*ermEp\**) was constructed via the deletion of 3 bp (TGG) in the  $-35$  region. This promoter is characterised by a much higher transcription activity (Schmitt-John and Engels 1992). It was successfully used for the expression of genes and gene clusters in various *Streptomyces*. The expression of the positive regulator *ttmRIV* under the control of *ermEp\** led to enhanced tetracycline production in *S. hygroscopicus* (Cui et al. 2015). Improved biosynthesis of 7 $\alpha$ -methoxycephalosporin C in *S. clavuligerus* was achieved after the overexpression of *cmcI* and *cmcJ* from *ermEp\** (Shao et al. 2014). Placing the *aurIP* regulator under the *ermEp\** promoter causes the overproduction of angucycline-like antibiotic auricin in *S. aureofaciens* (Novakova et al. 2011). Expression of the jadomycin gene cluster from the *ermEp\** promoter led to its overproduction in *S. venezuelae* (Zheng et al. 2007). The activation of pladienolide production in *S. avermitilis* was achieved via placing the *pldR* transcriptional regulator under the control of *ermEp\** (Komatsu et al. 2010).

Another strong promoter (*SF14p*) developed for *Streptomyces* possesses two times stronger activity than *ermEp\** and was obtained from the *S. ghanaensis* phage 119 (Labes et al. 1997). In general, *SF14p* contains two tandemly arranged promoters (14-lp and p14-11p) with overlapping and adjacent  $-10$  and  $-35$  regions, respectively, that are recognised by the major RNA polymerase enzyme but with different efficiency (Labes et al. 1997). However, despite its higher activity, this promoter did not find wide utility in *Streptomyces* genetics (for unknown reasons).

Based on the promoter of the *kasO* regulatory gene that encodes for the activator of a coelimycin P1 gene cluster in *S. coelicolor* A3, a new constitutive and highly active promoter *kasOp\** was constructed (Wang et al. 2013). This was achieved by the deletion of the operator-binding sites for ScbR1 and R2 upstream of the core region and a mutation in the internal ScbR-binding site. The *kasOp\** promoter showed higher activity than *ermEp\** and *SF14p* in the three streptomycetes hosts tested: *S. coelicolor*, *S. venezuelae* and *S. avermitilis* (Wang et al. 2013). This promoter was applied for actinorhodin overproduction. Several attempts were made to utilise the promoters of some of housekeeping genes because in most cases, they should have a high level of activity; however, they might be susceptible to different internal and external signals in the cells (Rebets et al. 2014a).

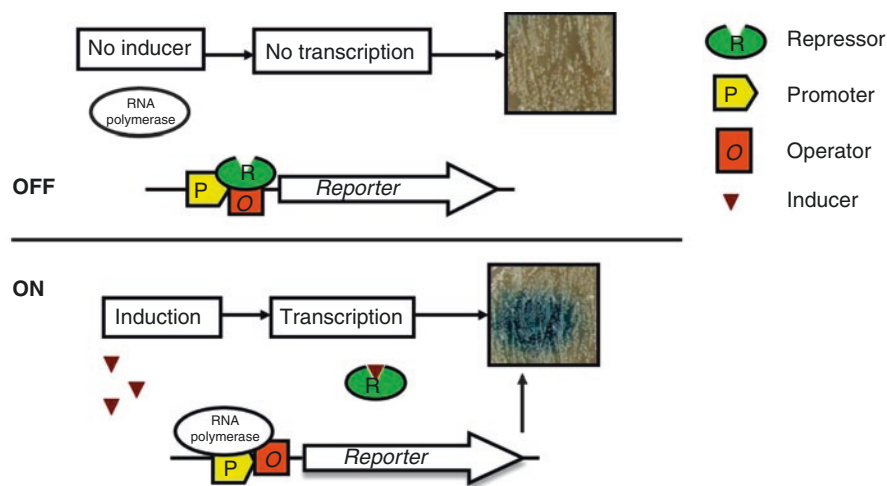
To avoid or at least reduce the influence of host factors, promoters from different organisms or semi- and synthetic elements might be used for gene expression regulation. Recently, a library of semi-synthetic constitutive promoters based on consensus  $-10$  and  $-35$  sequences of *ermEp1* was created (Siegl et al. 2013). For this purpose, the nucleotides located upstream, in between and downstream of these sequences were randomly synthesised. As a result, promoters with a strength ranging from 2 to 319% in comparison with *ermEp1* were obtained. The strongest promoter in the library is two times more active than *ermEp1*. These promoters were successfully applied for the creation of a library of inducible promoters



(Horbal et al. 2014a; Horbal and Luzhetskyy 2016) and for the activation of gene cluster expression (Myronovskiy et al. 2016).

Another collection of constitutive promoters was obtained through a randomization of the spacer regions upstream, in between and downstream of the consensus  $-10$  and  $-35$  sequences of *Streptomyces* promoters belonging to the  $\sigma^{70}$ -like family (Strohl 1992; Seghezzi et al. 2011). However, none of the obtained promoters exceeded the strength of *ermEp1*.

Constitutive promoters provide certain constant level of a gene expression in the cell. However, because metabolite of interest or its intermediates might be toxic to a bacterial cell, there is a significant demand in the ability to switch on a biosynthetic pathway at a desired time point in the production process and repress it during biomass accumulation. Therefore, inducible expression systems are required to address this issue. In addition, a library of inducible promoters of various strengths is necessary to simultaneously modulate the transcription of many genes. Several inducible expression systems have been described for mycelial *Actinobacteria* (Holmes et al. 1993; Herai et al. 2004; Rodríguez-García et al. 2005; Rudolph et al. 2013; Horbal et al. 2014a; Horbal and Luzhetskyy 2016; Wang et al. 2016). All of them utilise the common principle of gene regulation and are comprised of the following components: regulator (in most cases repressor, however, can be an activator), promoter with operator site for repressor or activator binding and inducer (Fig. 5.6). When inducer is absent in the cell, then repressor binds to the promoter region and in this way precludes the access of RNA polymerase; thus the transcription is blocked. Upon adding the inducer, the latter interacts with the repressor and causes its dissociation from the promoter region (Fig. 5.6). As a result, RNA polymerase binds and performs transcription of gene of interest. In the case of activator, its binding recruits RNA polymerase to the promoter region or stimulates formation of the open RNA complex (Canals et al. 2012).



**Fig. 5.6** Schematic depiction of inducible system functioning based on repressor and its ligand

Several inducible systems based on a repressor protein and respective promoter that is induced with tiny amounts of antibacterial agent were constructed for *Actinobacteria*. One of the first utilises TipA protein that belongs to the MerR family of repressors, binds to the *tipAp* promoter and uses thiostrepton as an inducer (Holmes et al. 1993). Integrative and replicative vectors containing this inducible system were constructed to control gene expression (Smokvina et al. 1990; Takano et al. 1995). Another inducible system is based on TetR repressor from the Tn10 transposon and uses anhydro- and tetracycline as inducers (Rodríguez-García et al. 2005). Several inducible promoters were created via placing tetracycline operators in between, up- or downstream of the  $-10$  and  $-35$  consensus sequences of the *ermEp1* promoter from *Sacch. erythraea*. The *tcp830* promoter proved to be the most effective of the synthetic ones for providing strong promoter activity when induced and efficient repression. Recently, a new inducible system based on oxytetracycline responsive regulator OtrR, the *otrO* operator and the *otrB* promoter was constructed and named *Potr\** (Wang et al. 2016). It is characterised by the high level of induction and low level of leaky expression in the offstage. In addition, the *Potr\** promoter in the fully induced stage showed much higher level of activity than widely used constitutive promoters *ermEp\** and *kasOp\**. Finally, the *Potr\** expression system was applied to activate the expression of a silent jadomycin biosynthetic gene cluster in *S. venezuelae*. Despite the quite high expression level and versatility of above-mentioned systems, the main drawbacks of all of them are a leakage in the offstage and utilisation of bioactive compounds as inducers that might influence physiology of the cell and cause unknown outcomes. In addition, application of such systems with the combination of described inducers in industrial strains is impossible. Thus, alternative systems that use not toxic, absolutely safe and cheap inducers are required as well. One of the first such systems was based on GylR repressor and the *gylP1/P2* promoter and utilised glycerol as an inducer (Hindle and Smith 1994). However, this system is leaky and does not provide high level of expression, and in the case of the *A. teichomyceticus* strain, it provides constitutive level of gene expression (Horbal et al. 2013a, b).

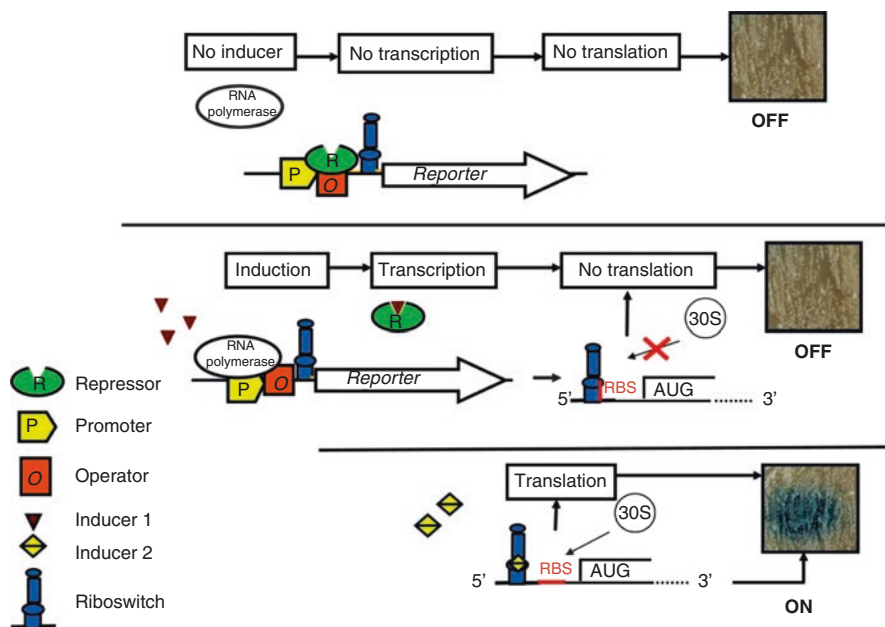
The PnitA-NitR system is based on expression mechanism of *Rhodococcus rhodochrous* J1 nitrilase, which is highly induced by an inexpensive and safe inducer *ε*-caprolactam (Herai et al. 2004). This system has proven to be tight and hyper-inducible, providing expression level higher than thiostrepton or tetracycline systems, as well as versatile, since it is functional in various *Streptomyces* strains (*S. coelicolor*, *S. avermitilis* and *S. griseus*). However, NitR system appears to be perfect for protein overproduction from high-copy number plasmids; it did not gain wide application for the control of biosynthetic pathways and other purposes.

Recently, two new inducible systems that utilise inexpensive and safe inducers were reported (Horbal et al. 2014a). A cumate (*p*-isopropylbenzoic acid)-inducible gene switch that is based on the CymR regulator, the operator sequence (*cmt*) from the *Pseudomonas putida* cumate degradation operon and the P21 synthetic promoter was developed for *Actinobacteria*. The resorcinol-inducible expression system is composed of the RolR regulator and the PA3 promoter fused with the operator (*rolO*) from the *Corynebacterium glutamicum* resorcinol catabolic operon. Using

the *gusA* ( $\beta$ -glucuronidase) gene as a reporter, it was shown that these expression systems are tightly regulated and hyper-inducible (Horbal et al. 2014a). The activity of the uninduced promoters is low in both cases. The systems are also dose dependent, which allows modulation of a gene expression even from a single promoter. In addition, the cumate system is versatile, given that it is functional in different *Actinomycetes*. Finally, a library of cumate-inducible promoters that allow fine-tuning expression of several genes/operons within the clusters is available (Horbal and Luzhetskyy 2016).

In general, the common feature of most of the expression systems described above is that they are not orthogonal and transcription is driven with the host RNA polymerases, which govern expression of numerous genes in the cell. The only system that is completely orthogonal is based on T7 RNA polymerase (RNAP) and T7 promoter and is widely used for *E. coli* and some other bacteria (Equbal et al. 2013; Drepper et al. 2005; Temme et al. 2012; Golomb and Chamberlin 1974). An advantage of T7 polymerase is that its promoters are completely inactive in the absence of the polymerase. In addition, this polymerase is characterised by a very high activity, elongating chains about five times faster than *E. coli* RNA polymerase (250 nucleotides per s compared with 50 in the case of *E. coli*), and can generate long mRNAs above 11 kb (Golomb and Chamberlin 1974; Studier and Moffatt 1986). Furthermore, this polymerase is insensitive to rifampicin treatment; therefore, the synthesis of all RNA molecules, as a consequence of proteins in the cell, can be blocked with the exception of those transcribed by the T7 polymerase. Taking into account the advantages of this system, attempts to adopt this one for *Streptomyces* were made as well. Two plasmids, one (pFXTipAT7) carrying T7 polymerase coding gene (codon optimised for expression in *Streptomyces*) under the control of thiostrepton-inducible promoter and the second one (pFX583) that contains neomycin resistance gene for selection and T7 promoter with MCS for cloning gene of interest, were constructed (Lussier et al. 2010). The efficacy of the system was demonstrated by overexpressing the *xln2* gene that encodes truncated version of xylanase A. No xylanase activity was detected in the absence of the inducer indicating the tightness of the system. However, the amount of the protein produced in the onstage was relatively low in comparison with that what can be obtained with noninducible *Streptomyces* expression systems.

Recently, a novel scaffolding architecture of an inducible regulatory device, named dual control system, was developed for *Actinobacteria* (Fig. 5.7) (Horbal and Luzhetskyy 2016). This system is completely silent in the offstage and enables a gene expression control at both transcriptional and translational levels (Fig. 5.7). Several variants of dual control system were described. They are based on cumate or resorcinol switches that are responsible for the regulation of gene expression at the transcriptional level (Horbal et al. 2014a) and the theophylline riboswitch (Rudolph et al. 2013) or the hammerhead ribozyme (Horbal et al. 2014a) that govern translation initiation. These are the tightest systems that are created for *Actinobacteria* to date. These devices function as AND gates, which are completely silent in the absence of both inputs and, at the same time, are highly inducible when both are present simultaneously. The effectiveness of the cumate-riboswitch dual



**Fig. 5.7** Operation of dual control system based on transcriptional repressor and theophylline riboswitch that control translation. *AUG* start codon, *30S* small subunit of ribosome, *RBS* ribosomal binding site

control system for the control of toxic compound production (pamamycin) in *S. albus* was demonstrated. A complete silence of the system in the offstage gives an opportunity to turn on the production of a natural product of interest at certain time point, for example, in the case of toxic products, it might be after biomass accumulation. Such a programmed behaviour of the dual control system allows accurately to control biosynthesis even of toxic products and in this way overcome their toxicity for the cells.

## Conclusion

In summary, a new direction in the genetics of *Actinobacteria* has evolved that is called “genome mining” and provides access to silent secondary metabolite pathways that were not known before and might be the source of new and fascinating natural products with unique structures and activities. Thus, there is a demand for reliable, bioinformatic-based analysis and prediction tools for potentially interesting pathways for activation. Because in most cases, native producers are not amenable for genetic manipulations and to avoid complex regulatory networks that exist in the host cell, well-defined chassis strains and synthetic Biobricks (promoters, RBSs and terminators) are utilised for their heterologous expression. There are a number of potential surrogate hosts derived from well-studied *Streptomyces* strains, such as *S. lividans*, *S. coelicolor* and *S. albus*,

or obtained from industrial producers. However, because of the diversity and complexity of natural compounds, even these highly productive hosts are not ideal and require rational multiple genetic modifications to obtain overproducers. Regardless, there is a large range of genetic engineering approaches, including ones that were not described above, for rational strain improvement and the genetic manipulation of *Actinobacteria*, although the simultaneous multiplex editing of their genomes is still a challenge. Thus, such techniques need to be established for mycelial *Actinobacteria* to accelerate rational strain improvement and gain access to new bioactive NPs. Another problem is the activation of the silent gene cluster that still requires tremendous and time-consuming efforts and is not 100% efficient because of unknown reasons. In general, the successful activation of gene clusters exceeds the simple substitution of native promoters with well-defined constitutive or inducible replacements. Therefore, a better understanding of the physiology of the strain, the biochemical mechanisms of compound biosynthesis and resistance, the metabolic flux of precursors, the tuning of the gene and the protein expression levels is required to force the biosynthesis of the compound of interest. It is clear that with the further development of functional genomics, metabolomics and systems, biology of mycelial *Actinobacteria*, together with other molecular biology and analytic techniques, will “decrypt the secrets” for turning on metabolite biosynthesis and will consequently reveal a hidden wealth of fascinating chemical compounds that might be produced by these bacteria.

**Acknowledgment** The research work in the laboratory of Andriy Luzhetskyy was supported by the European Commission under the 7th Framework Program through the “Collaborative Project” action “STREPSYNTH” grant No. 613877 and through the ERC starting grant EXPLOGEN No. 281623.

---

## References

- Alduina R, Gallo G (2012) Artificial chromosomes to explore and to exploit biosynthetic capabilities of actinomycetes. *J Biomed Biotechnol* 462049. doi:[10.1155/2012/462049](https://doi.org/10.1155/2012/462049)
- Allardet-Servent A, Michaux-Charachon S, Jumas-Bilak E, Karayan L, Ramuz M (1993) Presence of one linear and one circular chromosome in the *Agrobacterium tumefaciens* C58 genome. *J Bacteriol* 175(24):7869–7874
- Anné J, Wohlleben W, Burkardt HJ, Springer R, Pühler A (1984) Morphological and molecular characterisation of several actinophages isolated from soil which lyse *Streptomyces cattleya* or *Streptomyces venezuelae*. *J Gen Microbiol* 130:2639–2649
- Arai R, Ueda H, Kitayama A, Kamiya N, Nagamune T (2001) Design of the linkers which effectively separate domains of a bifunctional fusion protein. *Protein Eng* 14:529–532
- Bachmann BO, Van Lanen SG, Baltz RH (2014) Microbial genome mining for accelerated natural products discovery: is a renaissance in the making? *J Ind Microbiol Biotechnol* 41(2):175–184
- Baltz R (2017) Gifted microbes for genome mining and natural product discovery. *Journal of Industrial Microbiology & Biotechnology* 44(4–5):573–588
- Baltz RH (2008) Renaissance in antibacterial discovery from actinomycetes. *Curr Opin Pharmacol* 8(5):557–563

- Baltz RH (2011) Strain improvement in actinomycetes in the postgenomic era. *J Ind Microbiol Biotechnol* 38(6):657–666
- Baltz RH (2012) *Streptomyces* temperate bacteriophage integration systems for stable genetic engineering of actinomycetes (and other organisms). *J Ind Microbiol Biotechnol* 9(5):661–672
- Baltz RH (2017) Gifted microbes for genome mining and natural product discovery. *J Ind Microbiol Biotechnol* 44(4–5):573–588
- Baranasic D, Gacesa R, Starcevic A, Zucko J, Blazic M, Horvat M, Gjuracic K, Fujs S, Hranueli D, Kosec G, Cullum J, Petkovic H (2013) Draft genome sequence of *Streptomyces rapamycinicus* strain NRRL 5491, the producer of the immunosuppressant rapamycin. *Genome Announc* 1(4):e00581–e00513
- Barka EA, Vatsa P, Sanchez L et al (2015) Taxonomy, physiology, and natural products of actinobacteria. *Microbiol Mol Biol Rev* 80(1):1–43
- Bentley SD, Chater KF, Cerdeno-Tarraga AM et al (2002) Complete genome sequence of the model actinomycete *Streptomyces coelicolor* A3(2). *Nature* 417:141–147
- Bibb MJ, Janssen GR, Ward JM (1985) Cloning and analysis of the promoter region of the erythromycin resistance gene (*ermE*) of *Streptomyces erythraeus*. *Gene* 38(1–3):215–226
- Bierman M, Logan R, O'Brien K, Seno ET, Rao RN, Schonher BE (1992) Plasmid cloning vectors for the conjugal transfer of DNA from *Escherichia coli* to *Streptomyces* spp. *Gene* 116(1):43–49
- Bilyk O, Luzhetskyy A (2016) Metabolic engineering of natural product biosynthesis in actinobacteria. *Curr Opin Biotechnol* 42:98–107
- Bilyk B, Weber S, Myronovskiy M, Bilyk O, Petzke L, Luzhetskyy A (2013) In vivo random mutagenesis of streptomycetes using mariner-based transposon Himar1. *Appl Microbiol Biotechnol* 97(1):351–359
- Blattner FR, Plunkett G, Bloch CA, Perna NT, Burland V, Riley M, Collado-Vides J, Glasner JD, Rode CK, Mayhew GF, Gregor J, Davis NW, Kirkpatrick HA, Goeden MA, Rose DJ, Mau B, Shao Y (1997) The complete genome sequence of *Escherichia coli* K-12. *Science* 277:1453–1474
- Boissel S, Jarjour J, Astrakhan A et al (2014) megaTALs: a rare-cleaving nuclease architecture for therapeutic genome engineering. *Nucleic Acids Res* 42(4):2591–2601
- Branda CS, Dymecki SM (2004) Talking about a revolution: the impact of site-specific recombinases on genetic analyses in mice. *Dev Cell* 6(1):7–28
- Buttner MJ, Brown NL (1987) Two promoters from the *Streptomyces* plasmid pIJ101 and their expression in *Escherichia coli*. *Gene* 51(2–3):179–186
- Cadenas RF, Martín JF, Gil JA (1991) Construction and characterization of promoter-probe vectors for *Corynebacteria* using the kanamycin-resistance reporter gene. *Gene* 98(1):117–121
- Canals A, Blanco AG, Coll M (2012)  $\sigma$ 70 and PhoB activator: getting a better grip. *Transcription* 3(4):160–164
- Chandra G, Chater KF (2008) Evolutionary flux of potentially *bldA*-dependent *Streptomyces* genes containing the rare leucine codon TTA. *Antonie Van Leeuwenhoek* 94(1):111–126
- Chang AC, Cohen SN (1978) Construction and characterization of amplifiable multicopy DNA cloning vehicles derived from the P15A cryptic miniplasmid. *J Bacteriol* 134(3):1141–1156
- Chary VK, de la Fuente JL, Liras P, Martin JF (1997) Amy as a reporter gene for promoter activity in *Nocardia lactamdurans*: comparison of promoters of the cephamycin cluster. *Appl Environ Microbiol* 63(8):2977–2982
- Chen CW, Huang CH, Lee HH, Tsai HH, Kirby R (2002) Once the circle has been broken: dynamics and evolution of *Streptomyces* chromosomes. *Trends Genet* 18(10):522–529
- Chung ST (1987) Tn4556, a 6.8-kilobase-pair transposable element of *Streptomyces fradiae*. *J Bacteriol* 169(10):4436–4441
- Cobb RE, Wang Y, Zhao H (2015) High-efficiency multiplex genome editing of *Streptomyces* species using an engineered CRISPR/Cas system. *ACS Synth Biol* 4(6):723–728
- Cone MC, Petrich AK, Gould SJ, Zabriskie TM (1998) Cloning and heterologous expression of blasticidin S biosynthetic genes from *Streptomyces griseochromogenes*. *J Antibiot (Tokyo)* 51(6):570–578

- Craney A, Hohenauer T, Xu Y, Navani NK, Li Y, Nodwell J (2007) A synthetic luxCDABE gene cluster optimized for expression in high-GC bacteria. *Nucleic Acids Res* 35(6):e46
- Cui H, Ni X, Shao W et al (2015) Functional manipulations of the tetracycline positive regulatory gene *ttmRIV* to enhance the production of tetracycline A and nystatin A1 in *Streptomyces hygroscopicus*. *J Ind Microbiol Biotechnol* 42(9):1273–1282
- Damasceno JD, Beverley SM, Tosi LR (2010) A transposon toolkit for gene transfer and mutagenesis in protozoan parasites. *Genetica* 138(3):301–311
- Demain AL, Sanchez S (2009) Microbial drug discovery: 80 years of progress. *J Antibiot* 62:5–16
- Dickens ML, Strohl WR (1996) Isolation and characterization of a gene from *Streptomyces* sp. strain C5 that confers the ability to convert daunomycin to doxorubicin on *Streptomyces lividans* TK24. *J Bacteriol* 178(11):3389–3395
- Dickens ML, Ye J, Strohl WR (1996) Cloning, sequencing, and analysis of aklaviketone reductase from *Streptomyces* sp. strain C5. *J Bacteriol* 178(11):3384–3388
- Drepper T, Arvani S, Rosenau F, Wilhelm S, Jaeger KE (2005) High-level transcription of large gene regions: a novel T(7) RNA-polymerase-based system for expression of functional hydrogenases in the phototrophic bacterium *Rhodobacter capsulatus*. *Biochem Soc Trans* 33(Pt 1):56–58
- Eckhardt T, Strickler J, Gorniak L, Burnett WV, Fare LR (1987) Characterization of the promoter, signal sequence, and amino terminus of a secreted beta-galactosidase from “*Streptomyces lividans*”. *J Bacteriol* 169(9):4249–4256
- Eid J, Fehr A, Gray J et al (2009) Real-time DNA sequencing from single polymerase molecules. *Science* 323:133–138
- Enríquez LL, Mendes MV, Antón N, Tunca S, Guerra SM, Martín JF, Aparicio JF (2006) An efficient gene transfer system for the pimaricin producer *Streptomyces natalensis*. *FEMS Microbiol Lett* 257(2):312–318
- Eqbal MJ, Srivastava P, Agarwal GP, Deb JK (2013) Novel expression system for *Corynebacterium acetoacidophilum* and tools. *Appl Microbiol Biotechnol* 97(17):7755–7766
- Farkasovská J, Klucar L, Vlcek C, Kokavec J, Godány A (2007) Complete genome sequence and analysis of the *Streptomyces aureofaciens* phage mu1/6. *Folia Microbiol* 52:347–358
- Fedorushyn M, Welle E, Bechthold A, Luzhetskyy A (2008a) Functional expression of the Cre recombinase in actinomycetes. *Appl Microbiol Biotechnol* 78(6):1065–1070
- Fedorushyn M, Petzke L, Welle E, Bechthold A, Luzhetskyy A (2008b) Marker removal from actinomycetes genome using Flp recombinase. *Gene* 419(1–2):43–47
- Ferdows MS, Barbour AG (1989) Megabase-sized linear DNA in the bacterium *Borrelia burgdorferi*, the Lyme disease agent. *Proc Natl Acad Sci U S A* 86(15):5969–5973
- Fernández-Martínez LT, Del Sol R, Evans MC et al (2011) A transposon insertion single-gene knockout library and new ordered cosmid library for the model organism *Streptomyces coelicolor* A3(2). *Antonie Van Leeuwenhoek* 99(3):515–522
- Flärth K, Buttner MJ (2009) *Streptomyces* morphogenetics: dissecting differentiation in a filamentous bacterium. *Nat Rev Microbiol* 7(1):36–49
- Fleige C, Steinbüchel A (2014) Construction of expression vectors for metabolic engineering of the vanillin-producing actinomycete *Amycolatopsis* sp. ATCC 39116. *Appl Microbiol Biotechnol* 98(14):6387–6395
- Forsman M, Jaurin B (1987) Chromogenic identification of promoters in *Streptomyces lividans* by using an ampC beta-lactamase promoter-probe vector. *Mol Gen Genet* 210(1):23–32
- Gehring AM, Nodwell JR, Beverley SM, Losick R (2000) Genomewide insertional mutagenesis in *Streptomyces coelicolor* reveals additional genes involved in morphological differentiation. *Proc Natl Acad Sci U S A* 97:9642–9647
- Golomb M, Chamberlin M (1974) A preliminary map of the major transcription units read by T7 RNA polymerase on the T7 and T3 bacteriophage chromosomes. *Proc Natl Acad Sci U S A* 71(3):760–764
- Gomez-Escribano JP, Castro JF, Razmilic V et al (2015) The *Streptomyces leeuwenhoekii* genome: de novo sequencing and assembly in single contigs of the chromosome, circular plasmid pSLE1 and linear plasmid pSLE2. *BMC Genomics* 16:485
- Goryshin I, Jendrisak J, Hoffman L, Meis R, Reznikoff WS (2000) Insertional transposon mutagenesis by electroporation of released Th5 transposition complexes. *Nat Biotechnol* 18:97–100

- Gould SJ, Hong ST, Carney JR (1998) Cloning and heterologous expression of genes from the kinamycin biosynthetic pathway of *Streptomyces murayamaensis*. *J Antibiot (Tokyo)* 51(1):50–57
- Grabher C, Wittbrodt J (2008) Recent advances in meganuclease- and transposon-mediated transgenesis of medaka and zebrafish. *Methods Mol Biol* 461:521–539
- Gregory MA, Till R, Smith MC (2003) Integration site for *Streptomyces* phage phiBT1 and development of site-specific integrating vectors. *J Bacteriol* 185:5320–5323
- Guiney DG, Yakobson E (1983) Location and nucleotide sequence of the transfer origin of the broad host range plasmid RK2. *Proc Natl Acad Sci U S A* 80(12):3595–3598
- Ha HS, Hwang YI, Choi SU (2008) Application of conjugation using phiC31 att/int system for *Actinoplanes teichomyceticus*, a producer of teicoplanin. *Biotechnol Lett* 30:1233–1238
- Hastings JW, Gibson QH (1963) Intermediates in the bioluminescent oxidation of reduced flavin mononucleotide. *J Biol Chem* 238:2537–2554
- Heraï S, Hashimoto Y, Higashibata H, Maseda H, Ikeda H, Omura S, Kobayashi M (2004) Hyper-inducible expression system for streptomycetes. *Proc Natl Acad Sci U S A* 101(39):14031–14035
- Herrmann S, Siegl T, Luzhetskya M et al (2012) Site-specific recombination strategies for engineering actinomycete genomes. *Appl Environ Microbiol* 78(6):1804–1812
- Hindle Z, Smith CP (1994) Substrate induction and catabolite repression of the *Streptomyces coelicolor* glycerol operon are mediated through the GylR protein. *Mol Microbiol* 12(5):737–745
- Hirsch AM, Alvarado J, Bruce D et al (2013) Complete genome sequence of *Micromonospora* strain L5, a potential plant-growth-regulating actinomycete, originally isolated from *Casuarina equisetifolia* root nodules. *Genome Announc* 1(5) pii: e00759-13. doi:10.1128/genomeA.00759-13
- Hodge DR, Thompson DM, Panayiotakis A, Seth A (1995) Transcriptional activation analysis by the chloramphenicol acetyl transferase (CAT) enzyme assay. *Methods Mol Biol* 37:409–421
- Hoess RH, Ziese M, Sternberg N (1982) P1 site-specific recombination: nucleotide sequence of the recombinating sites. *Proc Natl Acad Sci U S A* 79(11):3398–3402
- Holmes DJ, Caso JL, Thompson CJ (1993) Autogenous transcriptional activation of a thiostrepton induced gene in *Streptomyces lividans*. *EMBO J* 12(8):3183–3191
- Hopwood DA (2006) Soil to genomics: the *Streptomyces* chromosome. *Annu Rev Genet* 40:1–23
- Horbal L, Luzhetskyy A (2016) Dual control system – a novel scaffolding architecture of an inducible regulatory device for the precise regulation of gene expression. *Metab Eng* 37:11–23
- Horbal L, Rebets Y, Rabyk M et al (2010) Characterization and analysis of the regulatory network involved in control of lipomycin biosynthesis in *Streptomyces aureofaciens* Tü117. *Appl Microbiol Biotechnol* 85(4):1069–1079
- Horbal L, Zaburanny N, Ostash B, Shulga S, Fedorenko V (2012) Manipulating the regulatory genes for teicoplanin production in *Actinoplanes teichomyceticus*. *World J Microbiol Biotechnol* 28(5):2095–2100
- Horbal L, Fedorenko V, Bechthold A, Luzhetskyy A (2013a) A transposon-based strategy to identify the regulatory gene network responsible for landomycin E biosynthesis. *FEMS Microbiol Lett* 342(2):138–146
- Horbal L, Kobylyanskyy A, Yushchuk O et al (2013b) Evaluation of heterologous promoters for genetic analysis of *Actinoplanes teichomyceticus* – producer of teicoplanin, drug of last defense. *J Biotechnol* 168(4):367–372
- Horbal L, Fedorenko V, Luzhetskyy A (2014a) Novel and tightly regulated resorcinol and cumate-inducible expression systems for *Streptomyces* and other actinobacteria. *Appl Microbiol Biotechnol* 98(20):8641–8655
- Huang H, Zheng G, Jiang W, Hu H, Lu Y (2015) One-step high-efficiency CRISPR/Cas9-mediated genome editing in *Streptomyces*. *Acta Biochim Biophys Sin Shanghai* 47(4):231–243. doi:10.1093/abbs/gmv007
- Ikeda H, Takada Y, Pang CH, Tanaka H, Omura S (1993) Transposon mutagenesis by Tn4560 and applications with avermectin-producing *Streptomyces avermitilis*. *J Bacteriol* 175(7):2077–2082
- Ikeda H, Ishikawa J, Hanamoto A et al (2003) Complete genome sequence and comparative analysis of the industrial microorganism *Streptomyces avermitilis*. *Nat Biotechnol* 21:526–531



- Ingram C, Brawner M, Youngman P, Westpheling J (1989) xylE functions as an efficient reporter gene in *Streptomyces* spp.: use for the study of galP1, a catabolite-controlled promoter. *J Bacteriol* 171(12):6617–6624
- Ishikawa J, Yamashita A, Mikami Y et al (2004) The complete genomic sequence of *Nocardia farcinica* IFM 10152. *Proc Natl Acad Sci U S A* 101(41):14925–14930
- Iwasaki A, Kishida H, Okanishi M (1986) Molecular cloning of a xylanase gene from *Streptomyces* sp. No. 36a and its expression in streptomycetes. *J Antibiot (Tokyo)* 39(7):985–993
- Jakimowicz D, Majka J, Messer W et al (1998) Structural elements of the *Streptomyces orificans* region and their interactions with the DnaA protein. *Microbiology* 144(Pt 5):1281–1290
- Jaurin B, Cohen SN (1985) *Streptomyces* contain *Escherichia coli*-type A + T-rich promoters having novel structural features. *Gene* 39(2–3):191–201
- Jeong H, Sim YM, Kim HJ et al (2013) Genome sequences of *Amycolatopsis orientalis* subsp. *orientalis* strains DSM 43388 and DSM 46075. *Genome Announc* 1(4). pii: e00545-13. doi:[10.1128/genomeA.00545-13](https://doi.org/10.1128/genomeA.00545-13)
- Jiang J, Tetzlaff CN, Takamatsu S et al (2009) Genome mining in *Streptomyces avermitilis*: a biochemical Baeyer–Villiger reaction and discovery of a new branch of the pentalenolactone family tree. *Biochemist* 48:6431–6440
- Katz L, Baltz RHJ (2016) Natural product discovery: past, present, and future. *J Ind Microbiol Biotechnol* 43(2–3):155–176
- Katz E, Thompson CJ, Hopwood DA (1983) Cloning and expression of the tyrosinase gene from *Streptomyces antibioticus* in *Streptomyces lividans*. *J Gen Microbiol* 129(9):2703–2714
- Kennedy EM, Cullen BR (2015) Bacterial CRISPR/Cas DNA endonucleases: a revolutionary technology that could dramatically impact viral research and treatment. *Virology* 479–480:213–220
- Khodakaramian G, Lissenden S, Gust B et al (2006) Expression of Cre recombinase during transient phage infection permits efficient marker removal in *Streptomyces*. *Nucleic Acids Res* 34(3):e20
- Kieser T, Hopwood DA, Wright HM, Thompson CJ (1982) pIJ101, a multi-copy broad host-range *Streptomyces* plasmid: functional analysis and development of DNA cloning vectors. *Mol Gen Genet* 185(2):223–228
- Kieser T, Bibb MJ, Buttner MJ, Chater KF, Hopwood DA (2000) *Practical Streptomyces genetics*. John Innes Foundation, Norwich
- Kirby R (2011) Chromosome diversity and similarity within the Actinomycetales. *FEMS Microbiol Lett* 319(1):1–10
- Knirschova R, Novakova R, Mingyar E, Bekeova C, Homerova D, Kormanec J (2015) Utilization of a reporter system based on the blue pigment indigoidine biosynthetic gene *bpsA* for detection of promoter activity and deletion of genes in *Streptomyces*. *J Microbiol Methods* 113:1–3
- Komatsu M, Uchiyama T, Omura S, Cane DE, Ikeda H (2010) Genome-minimized *Streptomyces* host for the heterologous expression of secondary metabolism. *Proc Natl Acad Sci U S A* 107(6):2646–2651
- Kuhstoss S, Richardson MA, Rao RN (1989) Site-specific integration in *Streptomyces ambofaciens*: localization of integration functions in *S. ambofaciens* plasmid pSAM2. *J Bacteriol* 171:16–23
- Kuhstoss S, Richardson MA, Rao RN (1991) Plasmid cloning vectors that integrate site-specifically in *Streptomyces* spp. *Gene* 97:143–146
- Labes G, Bibb M, Wohlleben W (1997) Isolation and characterization of a strong promoter element from the *Streptomyces ghanaensis* phage I19 using the gentamicin resistance gene (*aacC1*) of Tn 1696 as reporter. *Microbiology* 143(Pt 5):1503–1512
- Lam ET, Hastie A, Lin C et al (2012) Genome mapping on nanochannel arrays for structural variation analysis and sequence assembly. *Nat Biotechnol* 30:771–776
- Lampel JS, Aphale JS, Lampel KA, Strohl WR (1992) Cloning and sequencing of a gene encoding a novel extracellular neutral proteinase from *Streptomyces* sp. strain C5 and expression of the gene in *Streptomyces lividans* 1326. *J Bacteriol* 174(9):2797–2808
- Larson JL, Hershberger CL (1984) Shuttle vectors for cloning recombinant DNA in *Escherichia coli* and *Streptomyces griseofuscus* C581. *J Bacteriol* 157(1):314–317

- Larson JL, Hershberger CL (1986) The minimal replicon of a streptomycete plasmid produces an ultrahigh level of plasmid DNA. *Plasmid* 15(3):199–209
- Laver T, Harrison J, O'Neill PA et al (2015) Assessing the performance of the Oxford Nanopore Technologies MinION. *Biomol Detect Quantif* 3:1–8
- Leibig M, Krismer B, Kolb M, Friede A, Götz F, Bertram R (2008) Marker removal in staphylococci via Cre recombinase and different lox sites. *Appl Environ Microbiol* 74(5):1316–1323
- Li X, Zhou X, Deng Z (2003) Vector systems allowing efficient autonomous or integrative gene cloning in *Micromonospora* sp. strain 40027. *Appl Environ Microbiol* 69:3144–3151
- Li L, Guo J, Wen Y, Chen Z, Song Y, Li J (2010) Overexpression of ribosome recycling factor causes increased production of avermectin in *Streptomyces avermitilis* strains. *J Ind Microbiol Biotechnol* 37(7):673–679
- Lin YS, Kieser HM, Hopwood DA, Chen CW (1993) The chromosomal DNA of *Streptomyces lividans* 66 is linear. *Mol Microbiol* 10(5):923–933
- Liu H, Jiang H, Haltli B, Kulowski K, Muszynska E, Feng X, Summers M, Young M, Graziani E, Koehn F, Carter GT, He M (2009) Rapid cloning and heterologous expression of the meridamycin biosynthetic gene cluster using a versatile *Escherichia coli*-*streptomyces* artificial chromosome vector, pSBAC. *J Nat Prod* 72(3):389–395
- Liu G, HY O, Wang T et al (2010) Cleavage of phosphorothioated DNA and methylated DNA by the type IV restriction endonuclease ScoMcrA. *PLoS Genet* 6:e1001253
- Loman NJ, Constantinidou C, Chan JZ et al (2012) High-throughput bacterial genome sequencing: an embarrassment of choice, a world of opportunity. *Nat Rev Microbiol* 10:599–606
- Lomovskaya ND, Emejianova LK, Alikhanian SI (1971) The genetic location of prophage on the chromosome of *Streptomyces coelicolor*. *Genetics* 68(3):341–347
- Lopatniuk M, Ostash B, Makitrynsky R, Walker S, Luzhetskyy A, Fedorenko V (2015) Testing the utility of site-specific recombinases for manipulations of genome of moenomycin producer *Streptomyces ghanaensis* ATCC14672. *J Appl Genet* 56(4):547–450
- Lussier FX, Denis F, Shareck F (2010) Adaptation of the highly productive T7 expression system to *Streptomyces lividans*. *Appl Environ Microbiol* 76(3):967–970
- Magdevska V, Gaber R, Goranovič D et al (2010) Robust reporter system based on chalcone synthase *rppA* gene from *Saccharopolyspora erythraea*. *J Microbiol Methods* 83(2):111–119
- Manivasagan P, Kang KH, Sivakumar K, Li-Chan EC, Oh HM, Kim SK (2014) Marine actinobacteria: an important source of bioactive natural products. *Environ Toxicol Pharmacol* 38(1):172–188
- Mardis E (2008) Next-generation DNA sequencing methods. *Annu Rev Genomics Hum Genet* 9:387–402
- Mardis ER (2013) Next-generation sequencing platforms. *Annu Rev Anal Chem (Palo Alto, Calif)* 6:287–303
- Margulies M, Egholm M, Altman WE et al (2005) Genome sequencing in microfabricated high-density picolitre reactors. *Nature* 437:376–380
- Matsushima P, McHenney MA, Baltz RH (1987) Efficient transformation of *Amycolatopsis orientalis* (*Nocardia orientalis*) protoplasts by *Streptomyces* plasmids. *J Bacteriol* 169(5):2298–2300
- McCormick JR, Flärdh K (2012) Signals and regulators that govern *Streptomyces* development. *FEMS Microbiol Rev* 36:206–231
- Medema MH, Trefzer A, Kovalchuk A et al (2010) The sequence of a 1.8-mb bacterial linear plasmid reveals a rich evolutionary reservoir of secondary metabolic pathways. *Genome Biol Evol* 2:212–224
- Miao V, Coeffett-LeGal M-F, Brian P et al (2005) Daptomycin biosynthesis in *Streptomyces roseosporus*: cloning and analysis of the gene cluster and revision of peptide stereochemistry. *Microbiology* 151:1507–1523
- Mondou F, Shareck F, Morosoli R, Kluepfel D (1986) Cloning of the xylanase gene of *Streptomyces lividans*. *Gene* 49(3):323–329
- Morita K, Yamamoto T, Fusada N et al (2009) The site-specific recombination system of actinophage TG1. *FEMS Microbiol Lett* 297(2):234–240

- Murakami KS, Darst SA (2003) Bacterial RNA polymerases: the whole story. *Curr Opin Struct Biol* 13(1):31–39
- Myronovskiy M, Luzhetskyy A (2013) Genome engineering in actinomycetes using site-specific recombinases. *Appl Microbiol Biotechnol* 97(11):4701–4712
- Myronovskiy M, Welle E, Fedorenko V, Luzhetskyy A (2011) Beta-glucuronidase as a sensitive and versatile reporter in actinomycetes. *Appl Environ Microbiol* 77(15):5370–5383
- Myronovskiy M, Tokovenko B, Manderscheid N, Petzke L, Luzhetskyy A (2013) Complete genome sequence of *Streptomyces fulvissimus*. *J Biotechnol* 168:117–118
- Myronovskiy M, Rosenkränzer B, Luzhetskyy A (2014) Iterative marker excision system. *Appl Microbiol Biotechnol* 98(10):4557–4570
- Myronovskiy M, Brötz E, Rosenkränzer B, Manderscheid N, Tokovenko B, Rebets Y, Luzhetskyy A (2016) Generation of new compounds through unbalanced transcription of landomycin A cluster. *Appl Microbiol Biotechnol* 100(21):9175–9186
- Myronovskyy M, Ostash B, Ostash I, Fedorenko V (2009) A gene cloning system for the siomycin producer *Streptomyces sioyaensis* NRRL-B5408. *Folia Microbiol (Praha)* 54(2):91–96
- Nagy A (2000) Cre recombinase: the universal reagent for genome tailoring. *Genesis* 26(2):99–109
- Nah HJ, Woo MW, Choi SS, Kim ES (2015) Precise cloning and tandem integration of large polyketide biosynthetic gene cluster using *Streptomyces* artificial chromosome system. *Microb Cell Factories* 14:140
- Nguyen KD, Au-Young SH, Nodwell JR (2007) Monomeric red fluorescent protein as a reporter for macromolecular localization in *Streptomyces coelicolor*. *Plasmid* 58(2):167–173
- Novakova R, Kutas P, Feckova L, Kormanec J (2010) The role of the TetR-family transcriptional regulator AurI R in negative regulation of the auricin gene cluster in *Streptomyces aureofaciens* CCM 3239. *Microbiology* 156:2374–2383
- Novakova R, Rehakova A, Feckova L, Kutas P, Knischova R, Kormanec J (2011) Genetic manipulation of pathway regulation for overproduction of angucycline-like antibiotic auricin in *Streptomyces aureofaciens* CCM 3239. *Folia Microbiol (Praha)* 56(3):276–282
- Ohnishi Y, Ishikawa J, Hara H et al (2008) Genome sequence of the streptomycin-producing microorganism *Streptomyces griseus* IFO 13350. *J Bacteriol* 190:4050–4060
- Oliynyk M, Samborskyy M, Lester JB et al (2007) Complete genome sequence of the erythromycin-producing bacterium *Saccharopolyspora erythraea* NRRL23338. *Nat Biotechnol* 4:447–453
- Omura S, Ikeda H, Ishikawa J et al (2001) Genome sequence of an industrial microorganism *Streptomyces avermitilis*: deducing the ability of producing secondary metabolites. *Proc Natl Acad Sci U S A* 98(21):12215–12220
- Ostash B, Doud EH, Lin C et al (2009) Complete characterization of the seventeen step moenomycin biosynthetic pathway. *Biochemist* 48(37):8830–8841
- Ostash B, Ostash I, Horbal L, Fedorenko V (2012) Exploring and exploiting gene networks that regulate natural products biosynthesis in actinobacteria. *Nat Prod J* 3(3):189–198
- Ostash B, Yushchuk O, Tistechok S et al (2015) The *adpA*-like regulatory gene from *Actinoplanes teichomyceticus*: in silico analysis and heterologous expression. *World J Microbiol Biotechnol* 31(8):1297–1301
- Paget MS, Hintermann G, Smith CP (1994) Construction and application of streptomycete promoter probe vectors which employ the *Streptomyces glaucescens* tyrosinase-encoding gene as reporter. *Gene* 146(1):105–110
- Pastwa E, Błasiak J (2003) Non-homologous DNA end joining. *Acta Biochim Pol* 50(4):891–908
- Pellic V, Reyrat JM, Gicquel B (1996) Expression of the *Bacillus subtilis* *sacB* gene confers sucrose sensitivity on mycobacteria. *J Bacteriol* 178(4):1197–1199
- Petzke L, Luzhetskyy A (2009) In vivo Tn5-based transposon mutagenesis of *Streptomyces*. *Appl Microbiol Biotechnol* 83(5):979–986
- Pidcock KA, Montencourt BS, Sands JA (1985) Genetic recombination and transformation in protoplasts of *Thermomonospora fusca*. *Appl Environ Microbiol* 50(3):693–695
- Porteus MH, Carroll D (2005) Gene targeting using zinc finger nucleases. *Nat Biotechnol* 23(8):967–973

- Quail MA, Smith M, Coupland P et al (2012) A tale of three next generation sequencing platforms: comparison of ion torrent, Pacific biosciences and illumina MiSeq sequencers. *Genomics* 13:341. doi:10.1186/1471-2164-13-341
- Raynal A, Karray F, Tuphile K, Darbon-Rongère E, Pernodet JL (2006) Excisable cassettes: new tools for functional analysis of *Streptomyces* genomes. *Appl Environ Microbiol* 72(7):4839–4844
- Rebets Y, Ostash B, Luzhetskyy A et al (2005) DNA-binding activity of LndI protein and temporal expression of the gene that upregulates landomycin E production in *Streptomyces globisporus* 1912. *Microbiology* 151(Pt 1):281–290
- Rebets Y, Brötz E, Tokovenko B, Luzhetskyy A (2014a) Actinomycetes biosynthetic potential: how to bridge in silico and in vivo? *J Ind Microbiol Biotechnol* 41(2):387–402
- Rebets Y, Tokovenko B, Lushchik I et al (2014b) Complete genome sequence of producer of the glycopeptide antibiotic Aculeximycin *Kutzneria albidia* DSM 43870T, a representative of minor genus of Pseudonocardiaceae. *BMC Genomics* 15:885
- Redenbach M, Scheel J, Schmidt U (2000) Chromosome topology and genome size of selected actinomycetes species. *Antonie Van Leeuwenhoek* 78(3–4):227–235
- Reeves AR, Post DA, Vanden Boom TJ (1998) Physical-genetic map of the erythromycin-producing organism *Saccharopolyspora erythraea*. *Microbiology* 144(Pt 8):2151–2159
- Rodríguez-García A, Combes P, Pérez-Redondo R, Smith MC, Smith MC (2005) Natural and synthetic tetracycline-inducible promoters for use in the antibiotic producing bacteria *Streptomyces*. *Nucleic Acids Res* 33(9):e87
- Rose K, Steinbüchel A (2002) Construction and intergeneric conjugative transfer of a pSG5-based cosmid vector from *Escherichia coli* to the polyisoprene rubber degrading strain *Micromonospora aurantiaca* W2b. *FEMS Microbiol Lett* 211(2):129–132
- Rückert C, Szczepanowski R, Albersmeier A et al (2014) Complete genome sequence of the actinobacterium *Actinoplanes friuliensis* HAG010964, producer of the lipopeptide antibiotic friulimycin. *J Biotechnol* 178:41–42
- Rudolph MM, Vockenhuber MP, Suess B (2013) Synthetic riboswitches for the conditional control of gene expression in *Streptomyces coelicolor*. *Microbiology* 159:1416–1422
- Sadowski PD (1995) The Flp recombinase of the 2-microns plasmid of *Saccharomyces cerevisiae*. *Prog Nucleic Acid Res Mol Biol* 51:53–91
- Sauer B, McDermott J (2004) DNA recombination with a heterospecific Cre homolog identified from comparison of the pac-c1 regions of P1-related phages. *Nucleic Acids Res* 32(20):6086–6095
- Schauer AT, Nelson AD, Daniel JB (1991) Tn4563 transposition in *Streptomyces coelicolor* and its application to isolation of new morphological mutants. *J Bacteriol* 173(16):5060–5067
- Schauer A, Raney M, Santamaria R et al (1988) Visualizing gene expression in time and space in the filamentous bacterium *Streptomyces coelicolor*. *Science* 240(4853):768–772
- Schmitt-John T, Engels JW (1992) Promoter constructions for efficient secretion expression in *Streptomyces lividans*. *Appl Microbiol Biotechnol* 36(4):493–498
- Schweizer HP (2003) Applications of the *Saccharomyces cerevisiae* FLP-FRT system in bacterial genetics. *J Mol Microbiol Biotechnol* 5:67–77
- Seghezzi N, Amar P, Koebmann B, Jensen PR, Virolle MJ (2011) The construction of a library of synthetic promoters revealed some specific features of strong *Streptomyces* promoters. *Appl Microbiol Biotechnol* 90(2):615–623
- Sekurova ON, Brautaset T, Sletta H et al (2004) In Vivo Analysis of the Regulatory Genes in the Nystatin Biosynthetic Gene Cluster of *Streptomyces noursei* ATCC 11455 reveals their Differential Control over Antibiotic Biosynthesis. *J Bacteriol* 186(5):1345–1354
- Sezonov G, Hagège J, Pernodet JL, Friedmann A, Guérineau M (1995) Characterization of pra, a gene for replication control in pSAM2, the integrating element of *Streptomyces ambifaciens*. *Mol Microbiol* 17(3):533–544
- Shao L, Huang JJ, Yu Y, Li MX, Pu T, Kan SD, Chen DJ (2014) Improvement of 7 $\alpha$ -methoxycephalosporins production by overexpression of cmcJ and cmcI controlled by promoter ermEp\* in *Streptomyces clavuligerus*. *J Appl Microbiol* 117(6):1645–1654

- Siegl T, Luzhetskyy A (2012) Actinomycetes genome engineering approaches. *Antonie Van Leeuwenhoek* 102(3):503–516
- Siegl T, Petzke L, Welle E, Luzhetskyy A (2010) I-SceI endonuclease: a new tool for DNA repair studies and genetic manipulations in streptomycetes. *Appl Microbiol Biotechnol* 87(4):1525–1532
- Siegl T, Tokovenko B, Myronovskiy M, Luzhetskyy A (2013) Design, construction and characterisation of a synthetic promoter library for fine-tuned gene expression in actinomycetes. *Metab Eng* 19:98–106
- Smokvina T, Mazodier P, Boccard F, Thompson CJ, Guéroux M (1990) Construction of a series of pSAM2-based integrative vectors for use in actinomycetes. *Gene* 94(1):53–59
- Sohaskey CD, Im H, Schauer AT (1992) Construction and application of plasmid- and transposon-based promoter-probe vectors for *Streptomyces* spp. that employ a *Vibrio harveyi* luciferase reporter cassette. *J Bacteriol* 174(2):367–376
- Solenberg PJ, Baltz RH (1991) Transposition of Tn5096 and other IS493 derivatives in *Streptomyces griseofuscus*. *J Bacteriol* 173(3):1096–1104
- Sosio M, Giusino F, Cappellano C, Bossi E, Puglia AM, Donadio S (2000) Artificial chromosomes for antibiotic-producing actinomycetes. *Nat Biotechnol* 18(3):343–345
- Stegmann E, Albersmeier A, Spohn M et al (2014) Complete genome sequence of the actinobacterium *Mycolatopsis japonica* MG417-CF17(T) (=DSM 44213T) producing (S,S)-N,N'-ethylenediaminedisuccinic acid. *J Biotechnol* 189:46–47
- Steiniger M, Metzler J, Reznikoff WS (2006) Mutation of Tn5 transposase beta-loop residues affects all steps of Tn transposition: the role of conformational changes in Tn5 transposition. *Biochemist* 45(51):15552–15562
- Sternberg N (1990a) Bacteriophage P1 cloning system for the isolation, amplification, and recovery of DNA fragments as large as 100 kilobase pairs. *Proc Natl Acad Sci U S A* 87(1):103–107
- Sternberg NL (1990b) Alternatives to YACs. *Genet Anal Tech Appl* 7(5):126–132
- Stinchi S, Azimonti S, Donadio S, Sosio M (2003) A gene transfer system for the glycopeptide producer *Nonomuraea* sp. ATCC39727. *FEMS Microbiol Lett* 225(1):53–57
- Strohl WR (1992) Compilation and analysis of DNA sequences associated with apparent streptomycete promoters. *Nucleic Acids Res* 20(5):961–974
- Studier FW, Moffatt BA (1986) Use of bacteriophage T7 RNA polymerase to direct selective high-level expression of cloned genes. *J Mol Biol* 189(1):113–130
- Sun J, Kelemen GH, Fernández-Abalos JM, Bibb MJ (1999) Green fluorescent protein as a reporter for spatial and temporal gene expression in *Streptomyces coelicolor* A3(2). *Microbiology* 145:2221–2227
- Sun Y, Zhou X, Liu J et al (2002) ‘*Streptomyces nanchangensis*’, a producer of the insecticidal polyether antibiotic nanchangmycin and the antiparasitic macrolide meilingmycin, contains multiple polyketide gene clusters. *Microbiology* 148:361–371
- Suzuki N, Nonaka H, Tsuge Y, Inui M, Yukawa H (2005) New Multiple-Deletion Method for the *Corynebacterium glutamicum* Genome, Using a Mutant *lox* Sequence. *Appl Environ Microbiol* 71(12):8472–8480
- Takano E, White J, Thompson CJ, Bibb MJ (1995) Construction of thiostrepton-inducible, high-copy-number expression vectors for use in *Streptomyces* spp. *Gene* 166(1):133–137
- Temme K, Hill R, Segall-Shapiro TH, Moser F, Voigt CA (2012) Modular control of multiple pathways using engineered orthogonal T7 polymerases. *Nucleic Acids Res* 40(17):8773–8781. Epub 2012 Jun 28
- Tetzlav CN, You Z, Cane DE, Takamatzu S, Êmura S, Ikeda H (2006) A gene cluster for biosynthesis of the sesquiterpene antibiotic pentalenolactone in *Streptomyces avermitilis*. *Biochemist* 45:6179–6186
- Tokovenko B, Rebets YU, Luzhetskyy A (2016) Automating assessment of the undiscovered biosynthetic potential of Actinobacteria. doi:[10.1101/036087](https://doi.org/10.1101/036087)
- Tong Y, Charusanti P, Zhang L, Weber T, Lee SY (2015) CRISPR-Cas9 based engineering of actinomycetal genomes. *ACS Synth Biol* 4(9):1020–1029
- Truman AW, Fan Q, Röttgen M, Stegmann E, Leadlay PF, Spencer JB (2008) The role of *cep15* in the biosynthesis of chloroeremomycin: reactivation of an ancestral catalytic function. *Chem Biol* 15(5):476–484

- Van Mellaert L, Mei L, Lammertyn E, Schacht S, Anné J (1998) Site-specific integration of bacteriophage VWB genome into *Streptomyces venezuelae* and construction of a VWB-based integrative vector. *Microbiology* 144(Pt 12):3351–3358
- Voeykova T, Emelyanova L, Tabakov V, Mkrtumyan N (1998) Transfer of plasmid pTO1 from *Escherichia coli* to various representatives of the order Actinomycetales by intergeneric conjugation. *FEMS Microbiol Lett* 162(1):47–52
- Volff JN, Altenbuchner J (1997) High frequency transposition of the Tn5 derivative Tn5493 in *Streptomyces lividans*. *Gene* 194:81–86
- Wagner N, Osswald C, Biener R, Schwartz D (2009) Comparative analysis of transcriptional activities of heterologous promoters in the rare actinomycete *Actinoplanes friuliensis*. *J Biotechnol* 142(3–4):200–204
- Wang SB, Cantlay S, Nordberg N, Letek M, Gil JA, Flärth K (2009) Domains involved in the in vivo function and oligomerization of apical growth determinant DivIVA in *Streptomyces coelicolor*. *FEMS Microbiol Lett* 297:101–109
- Wang XJ, Yan YJ, Zhang B et al (2010) Genome sequence of the milbemycin-producing bacterium *Streptomyces bingchenggensis*. *J Bacteriol* 192(17):4526–4527
- Wang W, Li X, Wang J, Xiang S, Feng X, Yang K (2013) An engineered strong promoter for streptomycetes. *Appl Environ Microbiol* 79(14):4484–4492
- Wang W, Yang T, Li Y et al (2016) Development of a synthetic oxytetracycline-inducible expression system for *Streptomyces* using de novo characterized genetic parts. *ACS Synth Biol* 5(7):765–773
- Weaden J, Dyson P (1998) Transposon mutagenesis with IS6100 in the avermectin-producer *Streptomyces avermitilis*. *Microbiology* 144(Pt 7):1963–1970
- Wehmeier UF (1995) New multifunctional *Escherichia coli*-*Streptomyces* shuttle vectors allowing blue-white screening on XGal plates. *Gene* 165(1):149–150
- Wu H, Qu S, Lu C et al (2012) Genomic and transcriptomic insights into the thermo-regulated biosynthesis of validamycin in *Streptomyces hygroscopicus* 5008. *BMC Genomics* 13:337
- Xie Z, Li W, Tian Y, Liu G, Tan H (2007) Identification and characterization of sawC, a whiA-like gene, essential for sporulation in *Streptomyces ansochromogenes*. *Arch Microbiol* 188(6):575–582
- Yamamura H, Ohnishi Y, Ishikawa J et al (2012) Complete genome sequence of the motile actinomycete *Actinoplanes missouriensis* 431(T) (= NBRC 102363(T)). *Stand Genomic Sci* 7(2):294–303
- Yanisch-Perron C, Vieira J, Messing J (1985) Improved M13 phage cloning vectors and host strains: nucleotide sequences of the M13mp18 and pUC19 vectors. *Gene* 33(1):103–119
- Zaburannyi N, Rabyk M, Ostash B, Fedorenko V, Luzhetskyy A (2014) Insights into naturally minimised *Streptomyces albus* J1074 genome. *BMC Genomics* 15:97
- Zeng H, Wen S, Xu W et al (2015) Highly efficient editing of the actinorhodin polyketide chain length factor gene in *Streptomyces coelicolor* M145 using CRISPR/Cas9-CodA(sm) combined system. *Appl Microbiol Biotechnol* 99(24):10575–10585
- Zhang X, Bao Y, Shi X, Ou X, Zhou P, Ding X (2012) Efficient transposition of IS204-derived plasmids in *Streptomyces coelicolor*. *J Microbiol Methods* 88(1):67–72
- Zhao C, Huang T, Chen W, Deng Z (2010a) Enhancement of the diversity of polyoxins by a thymine-7-hydroxylase homolog outside the polyoxin biosynthesis gene cluster. *Appl Environ Microbiol* 76:7343–7347
- Zhao W, Zhong Y, Yuan H et al (2010b) Complete genome sequence of the rifamycin SV-producing *Amycolatopsis mediterranei* U32 revealed its genetic characteristics in phylogeny and metabolism. *Cell Res* 20(10):1096–1108
- Zheng JT, Wang SL, Yang KQ (2007) Engineering a regulatory region of jadomycin gene cluster to improve jadomycin B production in *Streptomyces venezuelae*. *Appl Microbiol Biotechnol* 76(4):883–888
- Zotchev S, Haugan K, Sekurova O, Sletta H, Ellingsen TE, Valla S (2000) Identification of a gene cluster for antibacterial polyketide-derived antibiotic biosynthesis in the nystatin producer *Streptomyces noursei* ATCC 11455. *Microbiology* 146(Pt 3):611–619

D.İ. Kurtböke

---

## 6.1 Introduction

Following the pioneering research that revealed bioactive potential of *Actinomycetales* including the production of potent therapeutic agents such as the antibiotics (Waksman and Woodruff 1940), an intensive search for new and active isolates for this order of actinobacteria started throughout the world, and thousands of species were isolated and screened (Nolan and Cross 1988). Most of the isolation procedures involved random approaches with large-scale, indiscriminate sampling of the environment and the subsequent screening of the isolates for detection of bioactive compounds for pharmaceutical and industrial use (Nolan and Cross 1988). While industrial bioactivity screening techniques became increasingly effective, the early approaches to the isolation of bioactive actinobacteria remained inadequate in terms of generation of sound understanding on the existence and the functional diversity of the actinoflora layers of microflora in their natural environments (Goodfellow and Williams 1983). However, with the advancements in the molecular biology field including the postgenomic tools, our eco-taxonomical understanding on microorganisms is now moving into an advance level. This chapter will thus expand from the pre-genomic era studies and will provide an overview related to the generation of in-depth understanding on the true or transitory occurrence, diversity and eco-functional roles of *Actinomycetales* in diverse habitats using powerful molecular tools.

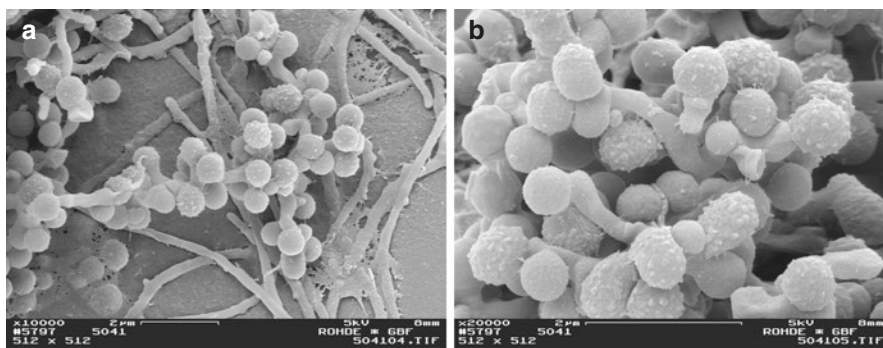
---

D.İ. Kurtböke  
GeneCology Research Centre and Faculty of Science,  
Health, Education and Engineering, School of Science and Engineering,  
University of the Sunshine Coast,  
Maroochydore DC, QLD 4558, Australia  
e-mail: [ikurtbok@usc.edu.au](mailto:ikurtbok@usc.edu.au)

## 6.2 Actinobacteria in Natural and Man-Made Environments

Intraclass relatedness of the class actinobacteria currently reveals the presence of nine orders (refer to LPSN [Bacterio.net](http://www.bacterio.net), accessed 31-01-2017 at <http://www.bacterio.net/-classifphylo.html>). In this chapter, “actinobacteria” will only refer to the “actinomycetes” covering the members of the order *Actinomycetales* in the historical sense. Again in this chapter, to accommodate the historical reasons, the order “*Actinomycetales*” will also include the newly created orders *Frankiales*, *Geodermatophiales*, *Kineosporiales* and *Micrococcales* (refer to LPSN [Bacterio.net](http://www.bacterio.net), accessed 31-01-2017 at <http://www.bacterio.net/-classifphylo.html>) as they were part of this order until recently.

The members of the order *Actinomycetales* are found in many habitats ranging from terrigenous, marine, aquatic, tidal flat ecosystems (Stevens et al. 2007) to aerial, extreme environments as well as in symbiotic associations with a variety of macroorganisms such as marine sponges, tunicates (Lee et al. 2001), ants (Poulsen et al. 2005) and termites (Kurtböke et al. 2015). Due to their hydrolytic abilities, they can contribute towards biodegradation of many recalcitrant compounds such as the ones associated with the faecal bacterial community of an African millipede (Oravecz et al. 2002). Examples include their ability to dissolve rubber gaskets in the water supply systems, grow in jet fuel tanks and stain plastics (Hedrick et al. 1968; Lechevalier 1974, 1981). To be able to understand the existence of actinobacteria in natural environments, information on their dormancy, sporulation (see Chap. 3 of this book) and the roles of their metabolites (e.g. antibiotics) produced in nature is also required. Early direct microscopic observations provided evidence on aerial mycelium formation and sporulation, mostly likely by streptomycetes in natural environments (Kubiena and Renn 1935; Starkey 1938; Erikson 1947a,b, b; Johnston and Cross 1976; Kalakoutskii and Agre 1976). Types of sporulation characteristics of actinomycetes in laboratory cultures were reported to be also observed in soil (Kalakoutskii and Agre 1976) (see Fig. 6.1 for the development of *Micromonospora* spores under laboratory cultivation on oatmeal agar. Note the transformation from smooth spore surface to warty one upon maturation).



**Fig. 6.1** Development of spores by a *Micromonospora* species (USC-5041) isolated in Sunshine Coast, Australia



Microbial metabolites exhibit a wide range of biological activities such as defence, regulation and communication (Bérdy 2012), and in nature, they will only be produced after receipt of specific signals, such as from the environment (stress) or from surrounding microorganisms (symbionts or competitors) (Zhu et al. 2014). Antibiotic secretions were also reported to be linked to biofilm formation (De Carvalho and Fernandes 2010) as well as acting as signals that enable symbiotic relationships between different organisms (Zhu et al. 2014). Bacteria can also produce molecules that prevent the attachment, growth and/or survival of challenging organisms in competitive environments (De Carvalho and Fernandes 2010). Pleiotropic switching, the simultaneous expression of sporulation and antibiotic biosynthesis, was also related to the defence roles of antibiotics (Stone and Williams 1992).

---

### 6.3 Actinobacteria in Terrestrial Habitats

Members of the order *Actinomycetales* constitute the significant component of soil microflora with viable counts over one million per gramme, although their numbers in waterlogged, anaerobic and acidic soils were reported to be lower ( $\times 10^2$ – $10^3$  per gramme dry weight of soil) (Goodfellow and Williams 1983). In relatively dry, humic, calcareous soils, actinobacteria, mostly the species of streptomycetes, form the dominant fractions of such soil microbiota (Goodfellow and Williams 1983). They are also found to be the constituents of litter, humus, dung, soil and even rock surfaces in greater numbers compared with the other natural environments they might be located (Cross 1981; Goodfellow and Williams 1983). They have also been associated in endophytic and actinorhizal relationships with plants as well as with mycorrhizae (Secilia and Bagyaraj 1987) and contributing significantly towards healthy plant establishments (for comprehensive review, see Lechevalier 1988).

Streptomycetes in soil were reported to be in dormant states in the form of arthrospores and chlamydo spores that germinate in the occasional presence of exogenous nutrients. New spore formations were found upon rapid mycelia colonization of organic substrates (Lloyd 1969; Mayfield et al. 1972). Streptomycete spores can also be dispersed above the soil when soil aggregates are disturbed by rain or wind (Lloyd 1969), and within the soil, dispersal of these spores is affected by the movement of water and arthropods (Ruddick and Williams 1972). Conversely, non-spore-forming genera such as *Arthrobacter* were suggested to exist long periods as resting cocci (Luscombe and Gray 1974). Early studies using direct observations or homogenization methods indicated that dilution plate technique mostly revealed colonies of streptomycetes originating from spores (Goodfellow and Williams 1983; Lloyd 1969; Mayfield et al. 1972). Motile, peritrichously flagellated zoospores in sporangia on substrate mycelium for *Actinoplanes* species (Couch and Koch 1962; Higgins 1967; Kalakoutskii and Kusnetsov 1964; Willoughby 1976; Willoughby et al. 1972) as well as motile spores in vesicles for *Pilimelia* were also reported (Kane 1966). Motile cells of *Actinosynnema pretiosum* subsp. *auranticum*, a rare actinobacterial genus member, were also observed (Tanida et al. 1984).

Although nutrient availability was shown to be a major factor controlling the activities of actinobacteria in soil, various other factors such as temperature, pH, humidity and moisture content were also found to influence their activities. Soil type was indicated to exert an influence as can season and climate, as well as seasonal changes in different climatic regions. Temperature also was shown to have a determining effect on the size and composition of the actinobacterial populations in soil. Pre-metagenomical era studies conducted using conventional approaches indicated that the numbers of streptomycetes in grassland were higher in summer (Küster 1976), nocardiae were most numerous in winter (Orchard 1981), and *Streptomyces malachiticus* (Küster 1970) and *Nocardia otitidis-caviarium* were confined to sub-tropical and tropical soils (Schaal and Bickenbach 1978).

pH was also found to be a major factor determining the distribution and activities of soil actinobacteria with an optimum existence around pH 7.0. The existence of neutrophilic streptomycetes in acidic soils was claimed to be due to the periodic occurrence of microsites of higher pH, produced by ammonification of substrates such as amino acids and chitin and initiated by acidophilic or aciduric soil microorganisms. These factors were also shown to influence the tolerance of neutrophilic actinobacterial spores to acidity (Flowers and Williams 1977; Khan and Williams 1975; Williams and Mayfield 1971). Alkali pH tolerance was also shown for actinobacteria (Mikami et al. 1982). Examples include *Streptomyces caeruleus* isolated from a Canadian salt lake that was found to grow at pH 6.5–9.5 (Taber 1960).

Moisture tension and aeration of soils that are intimately related were also found to affect soil microflora such as the major moisture content changes in Australian soils following rainstorms followed by subsequent drying process resulted in significant shifts in soil actinobacterial populations (Keast et al. 1984). Low moisture tensions (pF 1.0) lowered the radial growth of streptomycetes in soil but encouraged the maximum growth of mud-dwelling micromonosporae at pF 1.0 (Cross 1981).

Almost all soils contain a significant proportion of clay and humic colloidal materials, and adsorption occurs between colloids, microbial cells and their extracellular products, markedly affecting microbial activity at micro-environmental level (Chenu and Stotzky 2002). Addition of calcium montmorillonite to growth media used to cultivate *Streptomyces*, *Micromonospora* and *Nocardia* species accelerated their growth, glucose utilization and carbon dioxide evolution (Martin et al. 1976). Pesticides and herbicides were also shown to exert an influence on the actinobacterial populations. They can be detrimentally impacted or use these chemicals as growth substrates; examples include nocardiae that were found to utilize various fungicides as sole carbon and nitrogen sources (Bachofer et al. 1973). Hydrocarbon additions to soils were reported to stimulate *Arthrobacter* growth (Jensen 1975), and nocardiae and rhodococci were frequently found in petroleum-contaminated soils (Nesterenko et al. 1977).

With the use of current molecular approaches, our understanding is now expanding at an explosive rate related to the ecophysiology of actinobacteria in natural environments (Riesenfeld et al. 2004). A recent microcosmal experiment using a metagenomic technique, designed to assess the effect of benzene, toluene, ethylbenzene and xylenes (BTEX) on an indigenous bacterial community in a Daejeon forest soil, revealed the negative impact of such chemicals on actinobacterial community

(Ji et al. 2007). Chemical fertilizer and organic manure inputs were also reported to negatively impact indigenous actinoflora of paddy soils (Zhang et al. 2012).

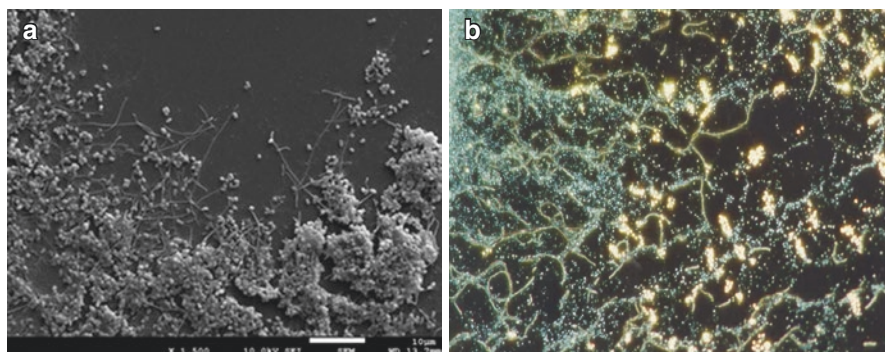
Until the late 1990s, the correlations between gross measurements of factors in the environment from which isolates originated and their responses to variation of the factors in laboratory culture formed the basis of our understanding on the responses of actinobacteria to physical and chemical factors. Determination of the limits and optima for the growth as well as the limits of viability was done using the correlation studies between in situ and in vitro (Williams 1986). However, in-depth research data required to conclude the subtle effects of spatial and temporal variations of factors within then studied environments were insufficient. This was mostly due to the effects of frequently random and destructive nature of the sampling procedures that was then used. Moreover, continually fluctuating factors which are difficult to measure such as aeration and moisture tension made macro-scale measurement of the environmental factors again then difficult (Williams 1986). However, with the emergence of effective in situ molecular techniques from the 1990s onwards, detection of the physiologically active roles of microorganisms in their native microbial communities has been possible (Felske et al. 1997; Hill et al. 2000). In addition, metagenomic and small subunit rRNA analyses revealed the genetic diversity of bacteria, archaea, fungi and viruses in soil (Fierer et al. 2007b), and the specific amplification of genes encoding 16S rRNA enabled the analysis of soil actinobacterial communities (Griffiths et al. 2004; Heuer et al. 1997). Molecular biological evidence also revealed the occurrence of uncultured members of the actinobacterial line of descent in different environments and geographical locations (Rheims and Stackebrandt 1999; Rheims et al. 1999) including detection of novel actinobacterial lineages in marine and terrestrial environments (McVeigh et al. 1996; Stach et al. 2003). Tracking microbial ecology through the use of molecular and genomic tools has become possible (Hirsch et al. 2010; López-García and Moreira 2008). Together with these molecular detection techniques, the effective multivariate analysis methods also facilitated the generation of in-depth knowledge in ecology and systematics (Ramette 2007). Biogeography has also emerged as a cornerstone approach to study diversity patterns of microorganisms at different biogeographic patterns within the context of evolutionary and ecological contexts (Ramette and Tiedje 2007). Impacts of evolutionary and ecological forces at microbial genotype level could also be identified (Ramette and Tiedje 2007).

Molecular advances have also brought new insights into the full understanding of the roles of *Actinomycetales* in the soil environments. One example is the definition of *Arabidopsis* root microbiome and its relationship with the soil microbial community. Through such advancements, extent of interactions between the endophytes and the host plants is revealed such as which bacterial genes are selected on the surface and internal root colonization (Bulgarelli et al. 2012; Hirsch and Mauchline 2012; Lundberg et al. 2012). Transcriptomics and proteomics are facilitating towards increased understanding related to when and where these genes are expressed as well as generation of sound understanding on the contribution of rhizosphere bacteria to both disease resistance and nutrient cycling such as the one illustrated in *Arabidopsis* model plant system. In the near future, a full understanding of the plant-microorganism-soil system gained through molecular advances will

be utilized to optimize plant health, nutrition and yields in sustainable agriculture (Bulgarelli et al. 2012; Hirsch and Mauchline 2012; Lundberg et al. 2012).

*Actinomycetales* members have also been known to contribute towards decomposition of complex components of soil, litter and composts such as starch, chitin, pectin, cellulose, hemicelluloses and lignocelluloses (Crawford 1988; Goodfellow and Williams 1983; McCarthy and Williams 1992; Williams and Robinson 1981). With these activities, they become an integral part in the recycling of materials in nature as well as contributing towards waste removal (for comprehensive review, see Crawford 1988). Chitin-decomposing actinomycetes associated with spores of a vesicular-arbuscular mycorrhizal fungus in field soil were also reported (Ames et al. 1989). Molecular advancements are also now aiding towards information generation into the enzymatic activities of actinobacteria in nature such as the molecular analysis of a bacterial chitinolytic community in an upland pasture (Metcalf et al. 2002). Functional screening of metagenomic libraries for genes involved in microbial biodegradation is now possible such as the aromatic compound (Suenaga et al. 2007) or lignocellulose degradation genes during composting (Wang et al. 2016). Through such molecular advances, detection of functional genes and linking them to the microbial community compositions as well as their functions in soils and composts is now possible (Waldrop et al. 2000), and such hydrolytic mechanisms *Actinomycetales* possess might be linked to their functionally conserved genes (McCarthy and Williams 1992).

*Actinomycetales* members can also cause disease such as tuberculosis, leprosy and actinomycoses in humans and farm animals. Presence of motile zoospores might also contribute towards disease dissemination such as the “lumpy wool” of sheep caused by *Dermatophilus congolensis* infections (Ambrose 1996). Their spores can also be dispersed into farm and related agricultural storage and processing plants and can cause allergic alveolitis leading to farmer’s lung, mushroom worker’s lung and tobacco workers’ lung disease as well as byssinosis and bagassosis (for comprehensive review, see Lacey 1988). Example photos of such spores originating from a *Saccharomonospora* isolate from sugar cane bagasse samples in Queensland, Australia, are illustrated in Fig. 6.2.



**Fig. 6.2** *Saccharomonospora* spores from an isolate obtained from sugar cane bagasse: (a) electron micrograph and (b) phase-contrast microscopy of the released spores (blue) from single spore-bearing clusters (white)

Biologically active members of the soil actinobacteria also produce the strong odour of freshly cultivated soils (Gerber and Lechevalier 1965; Zaitlin and Watson 2006), the characteristic property of compounds that are geosmin and 2-methylisoborneol and produced mostly by streptomycetes (Klausen et al. 2005).

Mitri and Foster (2013) investigated the social adaptations of microbial phenotypes through production of compounds that affect other cells. Examples include the secretion of enzymes to help other cells and the release of toxins to kill and phenotype that increases the fitness of another cell and that evolved at least in part because of this effect compete with neighbours. Microbial volatile organic compounds (mVOCs) were also reported to be part of the communication network that keeps microhabitats in balance, and morphological and phenotypical alterations and reactions that occur in microorganisms were also reported to be due to the presence of mVOCs (Effmert et al. 2012). Furthermore, these mVOCs were reported to be capable of interacting with plants in the soil environment and may promote plant growth directly, through induced systemic resistance (ISR), or indirectly, through suppression of phytopathogens (biocontrol) (Santoro et al. 2015).

These traits defined including at molecular level will define the ecological classification of soil bacteria (Fierer et al. 2007a), which in the long run will generate a holistic understanding on the ecophysiology and functional diversity of actinobacteria in diverse terrestrial habitats as well as contribute towards the design of effective culture-dependent techniques to recover the representatives of diverse functional groups of actinobacteria.

---

## 6.4 Actinobacteria in Aquatic and Marine Habitats

Marine actinobacteria, in particular the ones isolated from nearshore environments (e.g. shallow coastal sediments), were reported to be taxonomically related to known terrestrial genera and thus most likely to be originating from the dormant spores deposited in these environments from terrestrial runoffs (for comprehensive review, see Cross 1981). One interesting example has been the occurrence of *Rhodococcus coprophilus* in stream sediments and lake muds. These organisms can be isolated from dung of domesticated herbivores, and its coccal survival stage contaminates grass in pastures or hay used during the winter months for fodder. It remains viable after ingestion by these farm animals and passage through the rumen. Once excreted, it is washed into streams and rivers and can be isolated in high numbers from stream sediments and lake mud. The ratio of *R. coprophilus* to other actinomycetes in stream water samples can thus provide a useful index for detecting the presence of dairy farm effluents (Rowbotham and Cross 1977).

Molecular and advanced sampling procedures (Bull et al. 2000, 2005) have also revealed the existence of truly marine-adapted actinobacteria. Examples include *Rhodococcus marinonascens* (Helmke and Weyland 1984) as well as the novel genus *Salinispora* (Mincer et al. 2002; Maldonado et al. 2005; Ahmed et al. 2013; Jensen et al. 2015) with reported widespread distribution of its species in marine environments (Jensen and Mafnas 2006; Freel et al. 2012). Further studies described these new genus members as a monophyletic clade within the family

*Micromonosporaceae* (Mincer et al. 2002) and their genomic islands harbouring functional traits that were linked to their adaptation in marine environments (Penn et al. 2009). *Salinisporae* resistance to osmotic down-shocks was also investigated by Bucarey et al. (2012) through the transfer of *mscL* gene from a *Micromonospora* strain that was capable of growth on media prepared with deionized water into *S. tropica* strain CNB-440. This single-copy, chromosomal genetic complementation yielded a recombinant *Salinispora mscL* strain that subsequently demonstrated an increased capacity to survive osmotic down-shock. The loss of *mscL* gene resulted with the failure of the *Salinispora* sp. to grow in low-osmotic-strength media that provided evidence on the marine adaptation and enhanced survival of the *S. tropica* transformant.

Molecular-level studies such as the one described above will reveal information on the true adaptational mechanisms resulting in the survival of actinobacteria in diverse aquatic habitats. Examples include, the detection of new actinobacterial species from the hydrothermal vent fluids in the Mariana Trough (~–2850 m) and Suiyo Seamount (~–1390 m) (Naganuma et al. 2007; Thornburg et al. 2010) and from hydrothermally active sediments of the Guaymas Basin (~–2005 m) (Teske et al. 2002; Thornburg et al. 2010). Possible actinobacterial presence was also reported for the guts of these vent invertebrates (Baross and Deming 1985; Thornburg et al. 2010).

Marine aggregate-associated bacteria have also been reported to be actively involved in the production of inhibitory compounds during interspecific interactions and the actinobacterial fraction displaying the highest inhibitory activity among the isolates from German Wadden Sea (Grossart et al. 2004). Such inhibitory activity was suggested to greatly influence interspecific interactions and impacting microbial degradation and remineralization of particulate organic matter in aquatic environments (Grossart et al. 2004).

Micromonosporae, the second largest bioactive fraction of actinobacteria (Tiwari and Gupta 2012), were also reported to contribute towards degradation of organic and recalcitrant matter in aquatic and marine environments (Cross 1981). They have been frequently located in nearshore and offshore marine sediments (Bredholt et al. 2008; Eccleston et al. 2008). de Menezes et al. (2008) using DNA gyrase B gene sequencing identified cellulose-degrading micromonosporae from fresh water lakes, and the most cellulolytic cluster members were closely related to *Micromonospora chalcea*. Wu et al. (2008) using a microarray-based characterization method defined the microbial community functional structure and heterogeneity in marine sediments from the Gulf of Mexico. Their findings indicated the presence of chitinolytic actinobacteria in the sediment samples other than micromonosporae such as the species of the genera *Arthrobacter*, *Cellulomonas*, *Amycolatopsis*, *Kurthia* and *Streptomyces*.

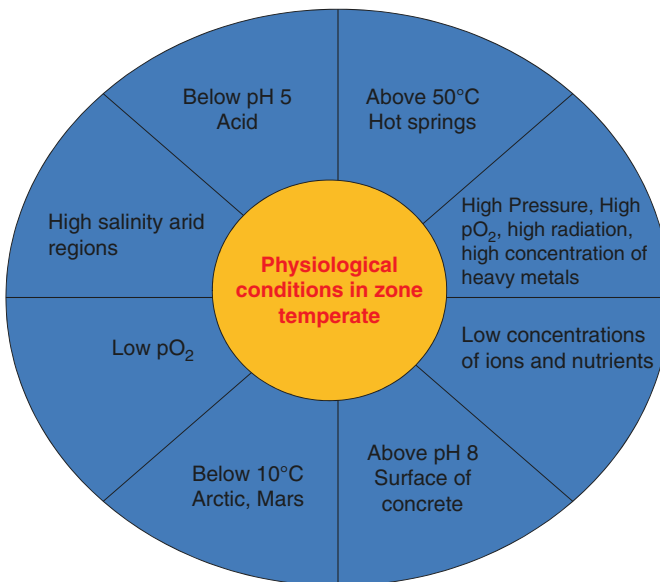
The phylogenetic affiliation of the phylotypes and the broad salinity range studies of the Wadden Sea Gram-positive bacterial community isolates by Grossart et al. (2004) indicated that these group of bacteria are well adapted and have become indigenous to such marine environment and because of their high potential to degrade various biopolymers, the members of these Gram-positive bacterial

community are important in the turnover and decomposition of organic matter in this ecosystem (Grossart et al. 2004).

Stach et al. (2003) examined actinobacterial diversity in a deep Atlantic Ocean sediment by comparing phylogenetic diversity and estimating species number using a number of statistical methods. Their findings indicated that species richness decreased with sediment depth with a concomitant decrease in genetic diversity and an increase in the level of dominance such as the formation of distinct species corresponding to separate ecological units. Pontarp et al. (2013) also revealed that habitat characteristics and environmental stress can “filter” a community so that only closely related species can persist. They also concluded that non-random phylogenetic signal might imply a relationship between ecologically relevant characteristics and species relatedness. Actinobacterial members of environmental communities should thus be examined under the definition of Pontarp et al. (2013).

## 6.5 Actinobacteria in Extreme Habitats

*Actinobacteria* were considered almost ubiquitous until the late 1980s (Lechevalier (1981). This was due to their infrequently encounters at extreme environments (see the chart by Bachofen 1986) (Fig. 6.3). However, again with the emergence of effective molecular tools, their existence is increasingly being reported at such extreme



**Fig. 6.3** Environmental factors which cause inhibition of growth and metabolism beyond certain limits. *Inner circle*: the so-called physiological range, conditions which are acceptable for men and in which most of higher organisms and a lot of microorganisms show the highest activity of life (from Bachofen 1986)

environments (Bull 2011). Examples include their association with the algal photosynthetic biofilms found in extreme acidic streams in Río Tinto (Huelva, Spain) (Souza-Egipsy et al. 2008) as well as the detection of the presence of *Mycobacterium* in this environment (García-Moyano et al. 2007). Liu et al. (2014) reported the abundance of *Actinobacteria* at the phylum level (*Acidimicrobiales* and *Rubrobacterales*) in an extreme and heterogeneous environment of mine tailings in China. Their findings indicated that the presence of actinobacteria was affected largely by  $\text{Fe}^{3+}$  concentrations. As they were reported to oxidize iron and sulphides previously (Clark and Norris 1996), Liu et al. (2014) suggested that there might be a role for *Actinobacteria* in the biogeochemical processes at this tailing site.

In Antarctic mineral soils, although high-frequency actinobacterial phylotype signals were detected, only few of these sequences matched to known phylotypes at >95% indicating the presence of yet-to-be-cultured psychrotrophic actinobacterial species (Smith et al. 2006). Other extreme habitats that received significant attention to identify their actinobacterial components include the Mariana Trench sediments collected at a depth of -10,898 m (Pathom-Aree et al. 2006). Hyperarid soils of the Atacama Desert (Bull and Asenjo 2013; Okoro et al. 2009), the high-altitude Andean Lakes (Ordoñez et al. 2009) and wetlands (Dib et al. 2008) and the anthropogenic extreme environments such as the ones with hyper-alkalinity and hypersalinity as well as contaminated with industrial residues containing chromium and iron (Brito et al. 2013) were also found to contain actinobacterial members. Subsurface rock colonization was reported to enhance the ability of microorganisms to resist radiation and desiccation due to the shielding effect of the rock matrix (Dong and Yu 2007). Molecular microbial diversity assessment studies, related to the endolithic colonization of silica-rich rhyolitic glass (obsidian) in a barren terrestrial volcanic environment located in Iceland, revealed that from the 47 bacterial sequences affiliated to six divisions, the most dominant division was reported to relate to *Actinobacteria* (Herrera et al. 2009). A radioresistant and psychrotrophic *Kocuria* sp. was also isolated from Ab-e-Siah radioactive spring (Asgarani et al. 2012). Radiotolerance has also been reported for actinobacteria in Tataouine desert (Chanal et al. 2006). Lipid storage in high-altitude Andean Lake associated extremophiles and its mobilization under stress conditions for a UV-resistant *Rhodococcus* sp. was reported (Urbano et al. 2013). Actinobacteria such as *Streptomyces coelicolor* A3(2) was reported to synthesize ectoine and 5-hydroxyectoine upon the imposition of either salt (0.5M NaCl) or heat stress (39 °C) (Bursy et al. 2008). Similarly, when desiccation-specific responses for *R. jostii* was investigated to define the genes and genetic mechanisms involved during desiccation stress, induced biosynthetic pathway for the compatible solute ectoine synthesis was also reported (LeBlanc et al. 2008).

Molecular identification of microbiota inhabiting an Antarctic cryoconite hole also revealed the presence of actinobacteria (Christner et al. 2003). Poly-extremophilism which refers to the combination of few different traits such as high-level salt tolerance, alkaline pH and elevated temperatures was reported to contribute towards survival of bacteria in such environments (Bowers et al. 2009).

The natural saline environments usually contain 4–30% NaCl, and adaptation to salinity by microorganisms is not only confined to aquatic and marine environments (e.g. salt marshes). The natural saline environments can also be located in terrestrial



environments such as increasing area of salt-affected cultivated soils throughout the world. Although these environments were reported to contain various ions that might interfere with uptake of water as well as being toxic to microbiota, they can also harbour taxonomically diverse bacterial groups with modified physiological and structural characteristics under the prevailing saline conditions (Zahran 1997). The majority of these bacteria can synthesize specific compatible organic osmolytes; as a result, they can osmoregulate (Zahran 1997). These characteristics empower them to survive in saline environments and contribute towards degradation of plant remains, fixing the nitrogen, and produce bioactive metabolites (Zahran 1997). Examples include isolation of a new actinobacterial species *Kocuria aegyptia* from a saline, alkaline desert soil in Egypt by Li et al. (2006). Actinobacteria in hypogean environments were also reported (Saiz-Jimenez and Groth 1999).

Current molecular advances (e.g. metagenomic approach with GeoChip-based functional gene arrays) also bring further evidence shaping the definition of functional ecology of bacteria inhabiting in extreme environments such as the Antarctic Dry Valley (Chan et al. 2013). Contribution to significant biochemical processes was identified for actinobacteria in these environments such as their ability to catabolize complex aromatic compounds in the studies.

Again metagenomical approaches will reveal the extent of microbial life in extreme temperature environments (Lewin et al. 2013). Bioinformatics will also aid to extract meaningful conclusions from the data. Kopcakova et al. (2014) stressed the urgent need for database extension for reliable identification of bacteria from extreme environments using MALDI-TOF mass spectrometry. Industrial needs will also aid towards generation of increased understanding on existence and functional diversity of extremophiles such as the thermostable enzyme producer ones such as the detection of extracellular enzymes from culturable *Actinobacteria* from the South Shetland Islands, Antarctica (Lamilla et al. 2016).

Another important development has been in the field of aero-microbiology that has provided evidence on the distribution of airborne microbial assemblages (Yamaguchi et al. 2012) as well as revealing the diversity of viable cells in the high atmosphere (Barberán et al. 2014). Dust coming from the large deserts on Earth, such as the Sahara, was shown to travel long distances and be dispersed over thousands of square kilometres as well as depositing in distant and different environments and seeding nonindigenous microbial representatives in such environments (e.g. remote oligotrophic alpine lakes) (Barberán et al. 2014). Dust-borne transport of microorganisms, particularly over aquatic environments, was indicated to be enhanced due to tolerable humidity levels and attenuation of UV by the particle load of the various dust clouds (Griffin 2007; Griffin et al. 2001).

---

## 6.6 Phages of Actinobacteria

Actinophages are viruses that infect the members of the order *Actinomycetales* and mostly belong to three viral families of *Myoviridae*, *Siphoviridae* and *Podoviridae* (see Figure 1 in Ackermann et al. 1985). Type species of actinophages for certain genera of the order *Actinomycetales* were described such as for the *Arthrobacter* (AN25S-1),

*Kurthia* (7/26), *Actinomyces* (Av-1), *Mycobacterium* (lacticola), *Streptomyces* (SV2), *Micromonospora* (ØUW21), *Thermomonospora* (Ø115A and Ta<sub>1</sub>) and *Micropolyspora* (Ø-150A) (Ackermann et al. 1985). *Siphoviridae* group of phages are the most common ones for *Actinomycetales* (Ackermann 2001, 2006). Cubic and filamentous phages were reported to be rare for actinophages (Ackermann et al. 1985) as well as the ones with contractile tails (Ackermann, personal communication 1995). Recent metagenomic and small subunit rRNA analyses revealed the genetic diversity between the soil and other natural environment-associated viruses. Soil is the main reservoir for actinophages (Robinson and Corke 1959). The most abundant actinophage types observed in the soil samples were reported to be similar to phages that infect the soil bacteria *Actinoplanes*, *Mycobacterium* and *Streptomyces* (Fierer et al. 2007b; Kutzner 1961; Pringsulaka et al. 2002). A group of bacteriophages specific to *Faenia rectivirgula* (Kempf et al. 1987) to *Actinomadura* species (Kurtböke et al. 1993a) and to *Nocardia restrictus* (Riverin et al. 1970) were also detected.

Like other bacteriophages, the actinophages can also impact host populations via several mechanisms including predation and alteration of host phenotype by genetic interactions (Marsh and Wellington 1994). The dynamic survival of phase populations in soil thus requires infective interactions with host populations which are actively growing (Marsh and Wellington 1994). As a result, the phase survival is limited by the activity of soil bacteria, and during the periods of inactivity phase, populations must adopt strategies to survive (Marsh and Wellington 1994). One of the most effective strategies used by phages was reported to be the lysogeny in soil that has a distinct advantage over virulence for phase and host survival (Marsh and Wellington 1994). Herron and Wellington (1990) suggested that temperate phase can introduce a gene into a population of streptomycetes in soil where lysogens persist and serve to spread the gene by spontaneous release of phase when nutrients are available.

Early studies on the detection of actinophages were reported to date back to 1936 (Hesseltine 1960). Following the lysis of streptomycin-producing strains of *Streptomyces griseus* that subsequently displayed strong proteolytic activity, the term “actinophage” was coined by the Waksman’s group (Reilly et al. 1947). Interest grew further due to the fact that most industrial cultures of antibiotic-producing actinomycetes were the lysogenic ones (Anné et al. 1990; Dowding and Hopwood 1973; Klaus et al. 1979, 1981; Lomovskaya et al. 1972; Shirai et al. 1991). In the later years, actinophage studies were conducted to detect and understand host-controlled restriction modification systems (e.g. *Micromonospora purpurea*) (Meyertons et al. 1987), and their further utilization as tools for genetic exchange for the bioactive members of the industrially important *Streptomyces* species (e.g. *Streptomyces coelicolor*) gained importance (Chater and Wilde 1976; Diaz et al. 1989). Phase-resistant mutants of antibiotic producer genera were also used to obtain superior producers. Examples include *S. erythreus* (Donadio et al. 1986), vancomycin-producing *Amycolatopsis* species (Parekh et al. 2000) and gentamicin-producing *Micromonospora purpurea* (Kikuchi and Perlman 1977).

Phase typing was also used for most *Actinomycetales* genera (Bradley and Anderson 1958; Bradley et al. 1961; Prauser 1970; Kurtböke 1996) to elucidate relationships between species as well as among species, genera and families. Such specific phase susceptibility was due to the adsorption to host receptors which were

present in only a very limited number of closely related species (Bradley et al. 1961; Korn-Wendisch and Schneider 1992). Wellington and Williams (1981) in conjunction with their extensive numerical phenetic study of the genus *Streptomyces* also investigated the phase susceptibility of the species to define the boundaries of the genus by the phase activity. Polyvalent streptophages recognized the host boundaries in agreement with the classification of the genus *Streptomyces* used in those days, and these phages were found to be family specific for the *Streptomycetaceae*. Phase cross infectivity was also recorded for then valid genera, *Chainia*, *Actinopycnidium*, *Actinosporangium*, *Microellobosporia* and *Kitasatoa*, indicating their close relatedness. These findings were in agreement with the subsequent amended description of the genus *Streptomyces* which catered all these above-listed genera within its genus boundaries (Goodfellow et al. 1986a, b, c). On the other hand, *Nocardioides* was found to be resistant to the *Streptomyces* phages and preserved its independent genus status (Prauser 1984; Williams et al. 1980), as well as the genera *Sporichthya* and *Kineosporia* (Prauser 1984). Most phages isolated against *Streptomyces* species since the studies begun have been reported to be polyvalent (El-Tarabily et al. 1995). Very few species-specific phages were reported such as the phase Ø2 for *S. albus* (Prauser and Falta 1968) and phase streptomycini III for *S. griseus* (Rautenstein 1967).

*Mycobacterium* phages (mycobacteriophages) have also received significant interest in terms of their contribution to the host pathogenicity. They provided essential tools for mycobacterial research, including reporter genes, mutagenesis and recent full genome sequences which indicated their further contributions into tuberculosis genetics (Hatfull 2014). Pedulla et al. (2003) studied genomic comparisons of mycobacteriophages and illustrated their roles in the horizontal gene transfer and a much broader involvement of these phages in the host virulence. They also suggested the roles of these recombinant events which lead to the inclusion of many unexpected genes including those implicated in mycobacterial infections and autoimmune diseases such as the human lupus. Detection of genome architectures of numerous mycobacteriophages revealed considerable sequence diversity and specificity, again providing a suite of tools for use in the mycobacterial genetic research (Dedrick et al. 2016). Similarly genome and proteome analysis of phase E3 infecting the soil-borne pathogen *Rhodococcus equi* brought new insights into host-phase interactions (Salifu et al. 2013).

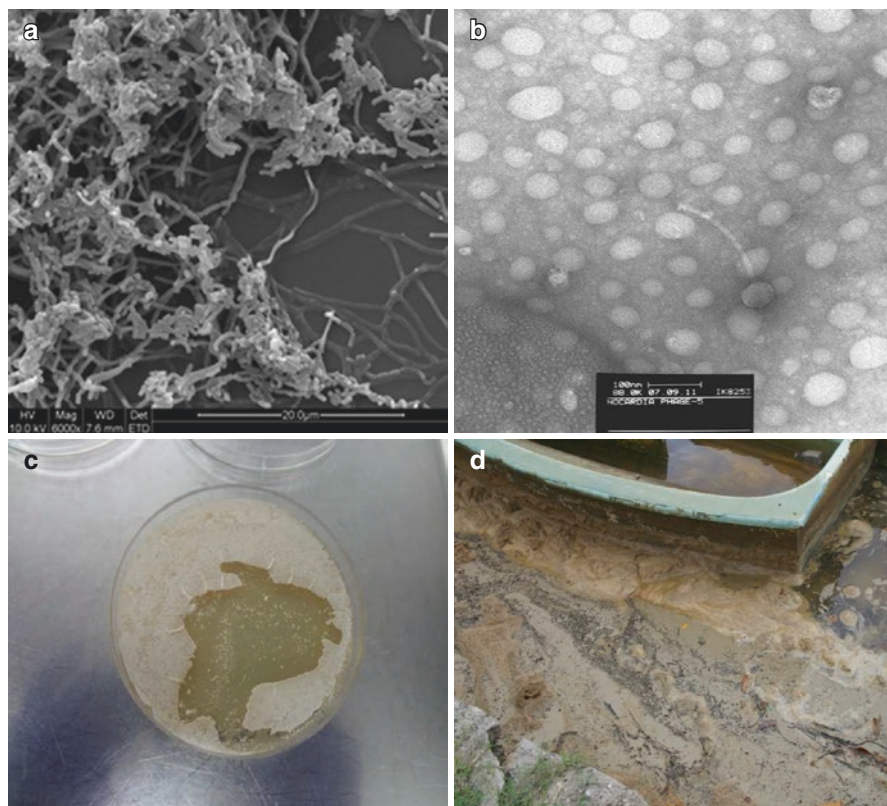
Prokaryotic CRISPR-Cas systems were reported to confer resistance to viral infection and thus mediate bacteria-phase interactions. Comparative genomic studies on a number of *Salinispora* strains confirmed recurring encounters with related phages as well as geographically confined mobile genetic elements (Wietz et al. 2014). These findings were suggested to be related to the presence of complex CRISPR-mediated interactions between *Salinispora* spp. and foreign genetic elements that might subsequently influence the ecology and evolution of this marine-adapted genus (Wietz et al. 2014).

Before the emergence of metagenomical tools that generate information on the host bacterial diversity in a selected substrate, actinophages were also used as indicators of the presence of rarely detected *Actinomycetales* genera (Williams et al. 1993; Kurtböke 2003, 2005, 2011; Kurtböke and French 2007). One of the recent examples that was related to the isolation of indicator phages, from the foaming sea

waters, surrounding beach and sand dune samples obtained from the Sunshine Coast region of Australia, revealed the presence of *Nocardiaceae* and *Pseudonocardiaceae* in such environments, and as a result, their subsequent selective isolations from these environments were achieved (Fig. 6.4) (Kurtböke 2016).

Association of the members of *Nocardiaceae* and *Pseudonocardiaceae* with foaming events frequently encountered in waste water treatment plants is well documented (Goodfellow et al. 1998; Lechevailier 1974; Soddell and Seviour 1990). Control of these foaming events in the activated sludge plants was attempted via the use of actinophages specific towards the members of these families by the researchers of La Trobe University over the last 15 years (Dyson et al. 2015; Petrovski et al. 2011, 2012; Thomas et al. 2002). Extensive genome-level studies on the phages isolated were subsequently conducted by these researchers enabling them to select obligatory lytic representatives of their phase library to be used to control foaming events in activated sludge plants (Dyson et al. 2015; Petrovski et al. 2011).

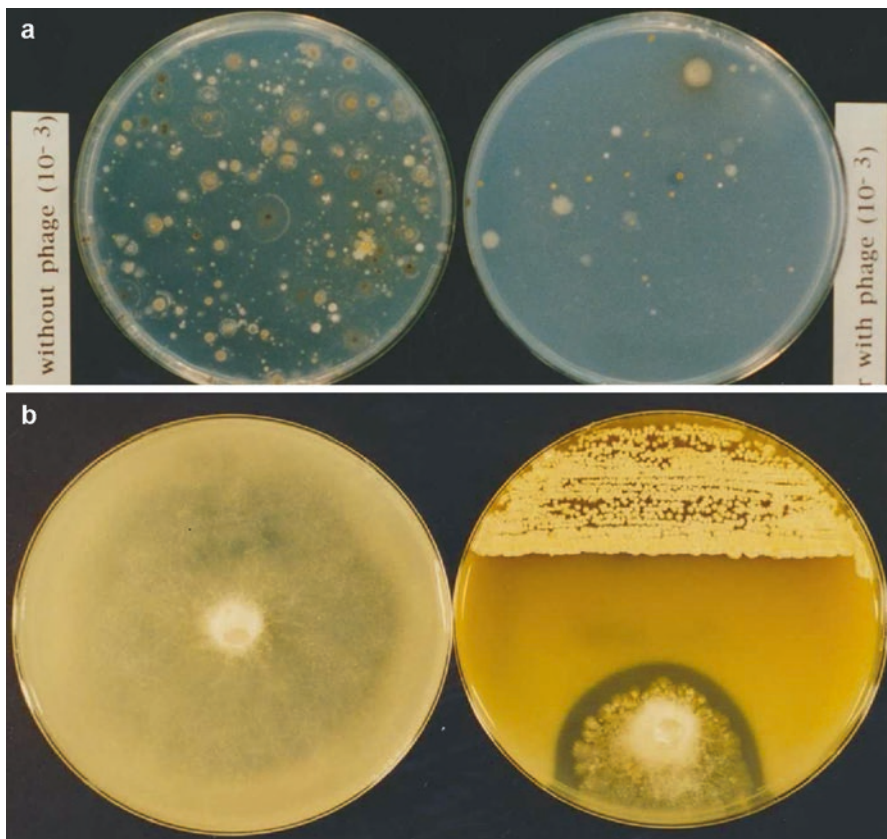
In a similar approach, phages specific to *Nocardiaceae* and *Pseudonocardiaceae*, which were isolated from the foaming sea waters of the Sunshine Coast region of Australia (Kurtböke 2008, 2016), were tested for their foam-forming ability in laboratory using aseptic conditions in the presence and absence of their specific phages.



**Fig. 6.4** Detection of (a) *Nocardia* species and (b and c) specific phage for this genus from (d) polluted marine environments of the Sunshine Coast, Australia

Created foams by these bacteria in sterile sea water-containing flasks with addition of different types of oils (e.g. peanut, vegetable, macadamia, olive, etc.) immediately lost their stability and collapsed when family-specific phages were added into the growing and foam-producing cultures of these families.

Actinophages have also successfully been used to deselect unwanted taxa on the isolation plates for the target-directed selective isolation of different *Actinomycetales* genera (Kurtböke and Williams 1991; Kurtböke et al. 1992; Kurtböke 2003, 2009). Streptomycetes or common bacteria overgrowing rare actinobacterial taxa by producing large colonies or through the production of inhibitory compounds on the isolation plates were removed using their polyvalent phages which improved the efficacy of culturability of rare actinomycetes (Kurtböke et al. 1992, 1993b; Kurtböke 2003, 2009). Such approach enabled the isolation of many non-streptomycete actinobacteria via the removal of overgrowing and common streptomycete colonies from isolation plates via the phase battery (El-Tarabily et al. 1995) (Fig. 6.5) to isolate antifungal actinomycetes for biological control purposes of plant pathogenic fungi (e.g. *Phytophthora* and *Pythium*) (El-Tarabily et al. 1996, 1997).



**Fig. 6.5** (a) Selective isolation of non-streptomycete actinobacteria using polyvalent streptophages to detect antifungal compound producing members of actinobacteria including (b) phase-resistant novel streptomycete species (El-Tarabily et al. 1996)

Actinophages have also been used as agrobiological control agents against bacterial phytopathogens including potato scab-causing *Streptomyces* species (Mckenna et al. 2001; Ogiso and Seishi 1999; Żaczek et al. 2015). Isolation of phase from the “lumpy wool” of sheep was also reported with potential to control *Dermatophilus congolensis* (Patten et al. 1994). They have also been used to prevent and control tuberculosis in the form of respirable aerosols (Hatfull and Vehring 2016).

For successful biological control implementation in the field, in-depth information on the host-phase interactions is required. Koskella (2013) presented evidence on phase-mediated selection of bacterial communities and bacterial-mediated selection of phase communities in nature. Such selection processes in a reciprocal fashion were claimed to play a key role in shaping the microbiota of their eukaryotic hosts, thus their likely protection from pathogens and pests. Bacteriophages have also been used as biological control agents or biopesticides (for comprehensive review, see Svircev et al. 2011). However, Meaden and Koskella (2013) cautioned about the possible adverse ecological effects of application of high concentrations of phages in the environment which might have on natural microbial communities leading to phase-mediated environmental perturbation as well as development of phase-resistant bacteria species.

Actinophages were also reported to encode for toxin productions by their hosts such as *Corynebacterium* (Freeman and Morse 1952; Groman 1953, 1955; Wagner and Waldor 2002) and *Rathayibacter toxicus* (former *Clavibacter toxicus*) (McKay et al. 1993; Ophel et al. 1993) which both have serious human (e.g. *Corynebacterium diphtheriae*) (Cerdeño-Tárraga et al. 2003) and animal health implications such as the annual rye grass toxicity (Riley and Gooden 1991). Again advance molecular tools provide further understanding on the exotoxin encoding mobile genetic elements in the natural environments including the phages (Casas et al. 2010).

On the other hand, in the recent years through functional viral metagenomics, identification of phase lysins (Schmitz et al. 2010) and production of bacteriophage-encoded lysins have also been possible (Dorval Courchesne et al. 2009). Virolysin encoded by *Actinomyces naeslundii* phase Av-1 was reported to prevent gingivitis and root surface caries formation by *Actinomyces naeslundii* which was resistant to lysozymes but sensitive to virolysins (Dorval Courchesne et al. 2009).

Currently advancing metagenomical studies are again enabling the assessment of the genetic diversity of the entire viral communities (virosphere) via the analysis of shotgun libraries of the total viral DNAs (Hambly and Suttle 2005) as well as bringing new insights on the viral mediated diversification of microbial diversity (Weinbauer and Rassoulzadegan 2004). All these molecular advances will result in increased understanding of host-phase interactions and their specificity in natural environments (Díaz-Muñoz and Koskella 2014; Koskella and Meaden 2013) and bacteria-phase coevolution as a driving source of ecological and evolutionary processes in microbial communities (Meaden and Koskella 2013; Koskella and Brockhurst 2014).

## 6.7 Conclusions: Impact of Molecular Advances on Actinobacterial Ecology and Future Directions

Actinobacteria are a successful group of bacteria that occur in a multiplicity of natural and man-made environments. Most are saprophytic, whereas some form parasitic and mutualistic associations with plants and animals and contribute towards the recycling of nutrients (Goodfellow and Williams 1983). Emerging metagenomical tools are now bringing new insights into their distribution, population dynamics, growth rates, degradative properties, survival, or dispersal or the factors governing the germination of dormant propagules of most actinomycete taxa natural environments.

High-throughput sequencing of RNA transcripts (RNA-seq) makes investigations possible revealing diverse physiologies from uncultured microorganisms in their natural habitat. Metatranscriptomes also shed light on microbial metabolism in situ as well as providing critical clues on target-directed recovery of uncultured microorganisms (Bomar et al. 2011). Knowledge generated on the nutritional preferences of bacteria design of selective culture medium becomes possible such as (i) choosing a condition under which the desired organism is rapidly proliferating, (ii) focusing on highly expressed genes encoding hydrolytic enzymes and (iii) binding proteins and (iv) transporters (Bomar et al. 2011).

Multifactorial metabolic exchange and quorum sensing during microbial interactions in nature were reported to not only influence the survival of microorganisms but also contribute towards morphological and developmental processes of the neighbouring microbial communities (Phelan et al. 2011; Ernebjerg and Kishony 2012). Accordingly, application of rigid ecological categories based on the culture representatives of microorganisms will not be possible any longer, and molecular advances will redefine such categories (Ernebjerg and Kishony 2012) including the eco-functional diversity of the most bioactive order *Actinomycetales*.

---

## References

- Ackermann HW (2001) Frequency of morphological phase descriptions. *Arch Virol* 146:843–857
- Ackermann HW (2006) Classification of bacteriophages. In: Calender R (ed) *The bacteriophages*. Oxford University Press, Oxford, pp 8–16
- Ackermann HW, Berthiaume L, Jones LA (1985) New actinophage species. *Dermatol Int* 23(3):121–130
- Ahmed L, Jensen PR, Freel KC, Brown R, Jones AL, Kim BY, Goodfellow M (2013) *Salinispora pacifica* sp. nov., an actinomycete from marine sediments. *A Van Leeuw* 103(5):1069–1078
- Ambrose NC (1996) The pathogenesis of dermatophilosis. *Trop Anim Health Prod* 28:29S–37S
- Ames RN, Mihara KL, Bayne HG (1989) Chitin-decomposing actinomycetes associated with a vesicular–arbuscular mycorrhizal fungus from a calcareous soil. *New Phytol* 111(1):67–71
- Anné J, Van Mellaert L, Decock B, Van Damme J, Van Aerschot A, Herdewijn P, Eyssen H (1990) Further biological and molecular characterization of actinophage VWB. *Microbiologica* 136(7):1365–1372
- Asgarani E, Soudi MR, Borzooee F, Dabbagh R (2012) Radio-resistance in psychrotrophic *Kocuria* sp. ASB 107 isolated from Ab-e-Siah radioactive spring. *J Environ Radioact* 113:171–176

- Bachofen R (1986) Microorganisms in extreme environments. *Experientia* 42(11-12):1179–1182
- Bachofer R, Oltmanns O, Lingens F (1973) Isolation and characterization of a *Nocardia*-like soil-bacterium, growing on carboxanilide fungicides. *Arch Microbiol* 90(2):141–149
- Barberán A, Henley J, Fierer N, Casamayor EO (2014) Structure, inter-annual recurrence, and global-scale connectivity of airborne microbial communities. *Sci Total Environ* 487:187–195
- Baross JA, Deming JW (1985) The role of bacteria in the ecology of black-smoker environments. *Bull Biol Soc Washing* 6:355–371
- Bérdy J (2012) Thoughts and facts about antibiotics: where we are now and where we are heading. *J Antibiot* 65:385–395
- Bomar L, Maltz M, Colston S, Graf J (2011) Directed culturing of microorganisms by use of meta-transcriptomics. *MBio* 2(2):e00012-11. doi:[10.1128/mBio.00012-11](https://doi.org/10.1128/mBio.00012-11)
- Bowers KJ, Mesbah NM, Wiegel J (2009) Biodiversity of poly-extremophilic Bacteria: Does combining the extremes of high salt, alkaline pH and elevated temperature approach a physico-chemical boundary for life? *Saline Syst* 5:9
- Bradley SG, Anderson DL (1958) Taxonomic implication of actinophage host-range. *Science* 128(3321):413–414
- Bradley SG, Anderson DL, Jones LA (1961) Phylogeny of actinomycetes as revealed by susceptibility to actinophage. *Dev Ind Microbiol* 2:223–237
- Bredholt H, Fjærvik E, Johnsen G, Zotchev SB (2008) Actinomycetes from sediments in the Trondheim fjord, Norway: diversity and biological activity. *Mar Drugs* 6(1):12–24
- Brito EM, Piñón-Castillo HA, Guyoneaud R, Caretta CA, Gutiérrez-Corona JF, Duran R, Reyna-López GE, Nevárez-Moorillón GV, Fahy A, Goñi-Urriza M (2013) Bacterial biodiversity from anthropogenic extreme environments: a hyper-alkaline and hyper-saline industrial residue contaminated by chromium and iron. *Appl Microbiol Biotechnol* 97(1):369–378
- Bucarey SA, Penn K, Paul L, Fenical W, Jensen PR (2012) Genetic complementation of the obligate marine actinobacterium *Salinispora tropica* with the large mechanosensitive channel gene *mscL* rescues cells from osmotic downshock. *Appl Environ Microbiol* 78(12):4175–4182
- Bulgarelli D, Rott M, Schlaeppli K et al (2012) Revealing structure and assembly cues for *Arabidopsis* root-inhabiting bacterial microbiota. *Nature* 488(7409):91–95
- Bull AT (2011) Actinobacteria of the extremobiosphere. In: Horikoshi K (ed) *Extremophiles Handbook*. Springer, Japan, pp 1203–1240. doi:[10.1007/978-4-431-53898-1\\_58](https://doi.org/10.1007/978-4-431-53898-1_58)
- Bull AT, Asenjo JA (2013) Microbiology of hyper-arid environments: recent insights from the Atacama Desert, Chile. *A Van Leeuw* 103(6):1173–1179
- Bull AT, Ward AC, Goodfellow M (2000) Search and discovery strategies for biotechnology: the paradigm shift. *Microbiol Mol Biol Rev* 64:573–606
- Bull AT, Stach JEM, Ward AC, Goodfellow M (2005) Marine actinobacteria: perspectives, challenges, future directions. *A Van Leeuw* 87:65–79
- Bursy J, Anne U, Kuhlmann AU et al (2008) Synthesis and uptake of the compatible solutes ectoine and 5-Hydroxyectoine by *Streptomyces coelicolor* A3(2) in response to salt and heat stresses. *Appl Environ Microbiol* 74(23):7286–7296
- Casas V, Magbanua J, Sobrepeña G, Kelley ST, Maloy SR (2010) Reservoir of bacterial exotoxin genes in the environment. *Int J Microbiol* 2010:754368. doi:[10.1155/2010/754368](https://doi.org/10.1155/2010/754368)
- Cerdeño-Tárraga AM, Efstratiou A, Dover LG et al (2003) The complete genome sequence and analysis of *Corynebacterium diphtheriae* NCTC13129. *Nucleic Acids Res* 31(22):6516–6523
- Chan Y, Van Nostrand JD, Zhou J, Pointing SB, Farrell RL (2013) Functional ecology of an Antarctic dry valley. *Proc Natl Acad Sci* 110(22):8990–8995
- Chanal A, Chapon V, Benzerara K et al (2006) The desert of Tataouine: an extreme environment that hosts a wide diversity of microorganisms and radiotolerant bacteria. *Environ Microbiol* 8(3):514–525
- Chater KF, Wilde LC (1976) Restriction of a bacteriophage of *Streptomyces albus* G involving endonuclease SalI. *J Bacteriol* 128(2):644–650
- Chenu C, Stotzky G (2002) Interactions between microorganisms and soil particles: an overview. In: Huang PM, Bollag J-M, Senesi N (eds) *Interactions between soil particles and microorgan-*



- isms: Impact on the terrestrial ecosystem. IUPAC. John Wiley & Sons, Ltd, Manchester, UK, pp 1–40
- Christner BC, Kvitko BH II, Reeve JN (2003) Molecular identification of bacteria and eukarya inhabiting an Antarctic cryoconite hole. *Extremophiles* 7(3):177–183
- Clark DA, Norris PR (1996) *Acidimicrobium ferrooxidans* gen. nov., sp. nov.: mixed-culture ferrous iron oxidation with *Sulfobacillus* species. *Microbiologica* 142:785–790
- Couch JN, Koch WJ (1962) Induction of motility in the spores of some Actinoplanaceae (Actinomycetales). *Science* 138:987
- Crawford DL (1988) Biodegradation of agricultural and urban wastes. In: Goodfellow M, Williams ST, Mordarski M (eds) *Actinomycetes in biotechnology*. Academic Press, London, pp 433–459
- Cross T (1981) Aquatic actinomycetes: a critical survey of the occurrence, growth and role of actinomycetes in aquatic habitats. *J Appl Bacteriol* 50(3):397–423
- De Carvalho CCCR, Fernandes P (2010) Production of Metabolites as Bacterial Responses to the Marine Environment. *Mar Drugs* 8:705–727
- de Menezes AB, Lockhart RJ, Cox MJ, Allison HE, McCarthy AJ (2008) Cellulose degradation by micromonosporas recovered from freshwater lakes and classification of these actinomycetes by DNA gyrase B gene sequencing. *Appl Environ Microbiol* 74(22):7080–7084
- Dedrick RM, Mavrich TN, Ng WL, Cervantes Reyes JC, Olm MR, Rush RE, Jacobs-Sera D, Russell DA, Hatfull GF (2016) Function, expression, specificity, diversity and incompatibility of actinobacteriophage parABS systems. *Mol Microbiol* 101(4):625–644
- Diaz LA, Hardisson C, Rodicio MR (1989) Isolation and characterization of actinophages infecting *Streptomyces* species and their interaction with host restriction-modification systems. *Microbiologica* 135(7):1847–1856
- Díaz-Muñoz SL, Koskella B (2014) Bacteria-phase interactions in natural environments. *Adv Appl Microbiol* 89:135–183
- Dib J, Motok J, Zenoff VF, Ordoñez O, Farías ME (2008) Occurrence of resistance to antibiotics, UV-B, and arsenic in bacteria isolated from extreme environments in high-altitude (above 4400 m) Andean wetlands. *Curr Microbiol* 56(5):510–517
- Donadio S, Paladino R, Costanzi I, Sparapani P, Schreil W, Iaccarino M (1986) Characterization of bacteriophages infecting *Streptomyces erythreus* and properties of phase-resistant mutants. *J Bacteriol* 166(3):1055–1060
- Dong H, Yu B (2007) Geomicrobiological processes in extreme environments: A review. *Episodes* 30(3):202–216
- Dorval Courchesne NM, Parisien A, Lan CQ (2009) Production and application of bacteriophage and bacteriophage-encoded lysins. *Recent Pat Biotechnol* 3(1):37–45
- Dowding JE, Hopwood DA (1973) Temperate bacteriophages for *Streptomyces coelicolor* A3(2) isolated from soil. *Microbiologica* 78(2):349–359
- Dyson ZA, Tucci J, Seviour RJ, Petrovski S (2015) Lysis to Kill: Evaluation of the lytic abilities, and genomics of nine bacteriophages infective for *Gordonia* spp. and their potential use in activated sludge foam biocontrol. *PLoS One* 10(8):e0134512. doi:[10.1371/journal.pone.0134512](https://doi.org/10.1371/journal.pone.0134512)
- Eccleston GP, Brooks PR, Kurtböke DI (2008) The occurrence of bioactive Micromonosporae in aquatic habitats of the sunshine coast in Australia. *Marine Drugs* 6(2):243–261
- Effmert U, Kalderás J, Warnke R, Piechulla B (2012) Volatile mediated interactions between bacteria and fungi in the soil. *J Chem Ecol* 38(6):665–703
- El-Tarabily KA, Kurtböke DI, Hardy G (1995) Partial characterization of *Streptomyces* phages isolated from the soils of jarrah forest in Western Australia. *Actinomycetes* 6(1):7–15
- El-Tarabily KA, Sykes ML, Kurtböke DI, Hardy GESJ, Barbosa AM, Dekker RFH (1996) Synergistic effects of a cellulase-producing *Micromonospora carbonacea* and an antibiotic producing *Streptomyces violaceus* on the suppression of *Phytophthora cinnamomi* root rot of *Banksia grandis*. *Can J Bot* 74:618–624
- El-Tarabily KA, Hardy GESJ, Sivasithamparam K, Hussein AM, Kurtböke DI (1997) The potential for the biological control of cavity spot disease of carrots caused by *Pythium coloratum* by streptomycete and non-streptomycete actinomycetes. *New Phytol* 137(3):495–507

- Erikson D (1947a) Differentiation of the vegetative and sporogenous phases of the actinomycetes: 1. The lipid nature of the outer wall of the aerial mycelium. *Microbiology* 1(1):39–44
- Erikson D (1947b) Differentiation of the vegetative and sporogenous phases of the actinomycetes: 2. Factors affecting the development of the aerial mycelium. *Microbiology* 1(1):45–52
- Ernebjerg M, Kishony R (2012) Distinct growth strategies of soil bacteria as revealed by large-scale colony tracking. *Appl Environ Microbiol* 78(5):1345–1352
- Felske A, Rheims H, Wolterink A et al (1997) Ribosome analysis reveals prominent activity of an uncultured member of the class Actinobacteria in grassland soils. *Microbiologica* 143(9):2983–2989
- Fierer N, Bradford MA, Jackson RB (2007a) Toward an ecological classification of soil bacteria. *Ecology* 88(6):1354–1364
- Fierer N, Breitbart M, Nulton J et al (2007b) Metagenomic and small-subunit rRNA analyses reveal the genetic diversity of bacteria, archaea, fungi, and viruses in soil. *Appl Environ Microbiol* 73(21):7059–7066
- Flowers TH, Williams ST (1977) Measurement of growth rates of streptomycetes: comparison of turbidimetric and gravimetric techniques. *Microbiology* 98(1):285–289
- Freel KC, Edlund A, Jensen PR (2012) Microdiversity and evidence for high dispersal rates in the marine actinomycete ‘*Salinispora pacifica*’. *Environ Microbiol* 14(2):480–493
- Freeman VJ, Morse IU (1952) Further observations on the change to virulence of bacteriophage-infected avirulent strains of *Corynebacterium diphtheriae*. *J Bacteriol* 63(3):407–414
- García-Moyano A, González-Toril E, Aguilera A, Amils R (2007) Prokaryotic community composition and ecology of floating macroscopic filaments from an extreme acidic environment, Rio Tinto (SW, Spain). *Syst Appl Microbiol* 30(8):601–614
- Gerber NN, Lechevalier HA (1965) Geosmin, an earthy-smelling substance isolated from actinomycetes. *Appl Microbiol* 13(6):935–938
- Goodfellow M, Williams ST (1983) Ecology of actinomycetes. *Annu Rev Microbiol* 37(1):189–216
- Goodfellow M, Williams ST, Alderson G (1986a) Transfer of *Elytrosporangium brasiliense* Falcão de Morais et al., *Elytrosporangium carpinense* Falcão de Morais et al., *Elytrosporangium spirale* Falcão de Morais et al., *Microellobosporia cinerea* Cross et al., *Microellobosporia flava* Cross et al., *Microellobosporia grisea* (Konev et al.) Pridham and *Microellobosporia violacea* (Tsyganov et al.) Pridham to the genus *Streptomyces*, with emended description of the species. *Syst Appl Microbiol* 8:48–54
- Goodfellow M, Williams ST, Alderson G (1986b) Transfer of *Chainia* species to the genus *Streptomyces* with emended description of species. *Syst Appl Microbiol* 8:55–60
- Goodfellow M, Williams ST, Alderson G (1986c) Transfer of *Actinosporangium violaceum* Krasil’nikov and Yuan, *Actinosporangium vitaminophilum* Shomura et al. and *Actinopycnidium caeruleum* Krasil’nikov to the genus *Streptomyces*, with emended description of the species. *Syst Appl Microbiol* 8:61–64
- Goodfellow M, Stainsby FM, Davenport R, Chun J, Curtis T (1998) Activated sludge foaming: the true extent of actinomycete diversity. *Water Sci Technol* 37(4–5):511–519
- Griffin DW (2007) Atmospheric movement of microorganisms in clouds of desert dust and implications for human health. *Clin Microbiol Rev* 20(3):459–477
- Griffin DW, Garrison VH, Herman JR, Shinn EA (2001) African desert dust in the Caribbean atmosphere: microbiology and public health. *Aerobiologia* 17:203–213
- Griffiths BS, Kuan HL, Ritz K et al (2004) The relationship between microbial community structure and functional stability, tested experimentally in an upland pasture soil. *Microb Ecol* 47(1):104–113
- Groman NB (1953) Evidence for the induced nature of the change from nontoxigenicity to toxigenicity in *Corynebacterium diphtheriae* as a result of exposure to specific bacteriophage. *J Bacteriol* 66(2):184–191
- Groman NB (1955) Evidence for the active role of bacteriophage in the conversion of nontoxigenic *Corynebacterium diphtheriae* to toxin production. *J Bacteriol* 69(1):9–15

- Grossart HP, Schlingloff A, Bernhard M, Simon M, Brinkhoff T (2004) Antagonistic activity of bacteria isolated from organic aggregates of the German Wadden Sea. *FEMS Microbiol Ecol* 47(3):387–396
- Hambly E, Suttle CA (2005) The virosphere, diversity, and genetic exchange within phase communities. *Curr Opin Microbiol* 8(4):444–450
- Hatfull GF (2014) Molecular genetics of mycobacteriophages. *Microbiology Spectrum* 2(2):1–36
- Hatfull GF, Vehring R (2016) Respirable bacteriophage aerosols for the prevention and treatment of tuberculosis. In: Hickey AJ, Misra A, Fourie PB (eds) *Delivery systems for tuberculosis prevention and treatment*. John Wiley & Sons, Ltd, Chichester, UK, pp 277–291
- Hedrick HG, Reynolds RJ, Crum MG (1968) Identification and viability of microorganisms from jet-fuel samples. *Dev Ind Microbiol* 9:415–425
- Helmke E, Weyland H (1984) *Rhodococcus marinonascens* sp. nov., an actinomycete from the sea. *Int J Syst Evol Microbiol* 34(2):127–138
- Herrera A, Cockell CS, Self S, Blaxter M, Reitner J, Thorsteinsson T, Arp G, Dröse W, Tindle AG (2009) A cryptoendolithic community in volcanic glass. *Astrobiology* 9(4):369–381
- Herron PR, Wellington EMH (1990) New method for extraction of streptomycete spores from soil and application to the study of lysogeny in sterile amended and nonsterile soil. *Appl Environ Microbiol* 56(5):1406–1412
- Hesseltine CW (1960) Relationships of the Actinomycetales. *Mycologia* 52(3):460–474
- Heuer H, Krsek M, Baker P, Smalla K, Wellington EM (1997) Analysis of actinomycete communities by specific amplification of genes encoding 16S rRNA and gel-electrophoretic separation in denaturing gradients. *Appl Environ Microbiol* 63(8):3233–3241
- Higgins ML (1967) Release of sporangiospores by a strain of *Actinoplanes*. *J Bacteriol* 94:495–498
- Hill GT, Mitkowski NA, Aldrich-Wolfe L, Emele LR, Jurkonie DD, Ficke A, Maldonado-Ramirez S, Lynch ST, Nelson EB (2000) Methods for assessing the composition and diversity of soil microbial communities. *Appl Soil Ecol* 15(1):25–36
- Hirsch PR, Mauchline TH (2012) Who's who in the plant root microbiome? *Nat Biotechnol* 30(10):961–962
- Hirsch PR, Mauchline TH, Clark IM (2010) Culture-independent molecular techniques for soil microbial ecology. *Soil Biol Biochem* 42(6):878–887
- Jensen PR, Mafnas C (2006) Biogeography of the marine actinomycete *Salinispora*. *Environ Microbiol* 8(11):1881–1888
- Jensen PR, Moore BS, Fenical W (2015) The marine actinomycete genus *Salinispora*: a model organism for secondary metabolite discovery. *Nat Prod Rep* 32(5):738–751
- Jensen V (1975) Bacterial Flora of Soil after Application of Oily Waste. *Oikos* 26(2):152–158
- Ji SC, Kim D, Yoon JH, Lee CH (2007) Metagenomic analysis of BTEX-contaminated forest soil microcosm. *J Microbiol Biotechnol* 17(4):668–672
- Johnston DW, Cross T (1976) Actinomycetes in lake muds: dormant spores or metabolically active mycelium? *Freshw Biol* 6(5):465–470
- Kalakoutskii LV, Agre NS (1976) Comparative aspects of development and differentiation in Actinomycetes. *Bacteriol Rev* 40(2):469–524
- Kalakoutskii LV, Kusnetsov VD (1964) A new species of the genus *Actinoplanes* Couch-A. *armenicus* and some peculiarities of its mode of spore formation. *Mikrobiologija* 33:613–621
- Kane WD (1966) A new genus of Actinoplanaceae, *Pilimelia*, with a description of two species *Pilimelia terevasa* and *Pilimelia anulata*. *J Elisha Mitchell Sci Soc* 82:220–230
- Keast D, Rowe P, Bowra B, Sanfelieu L, Stapley EO, Woodruff HB (1984) Studies on the ecology of West Australian actinomycetes: Factors which influence the diversity and types of actinomycetes in Australian soils. *Microb Ecol* 10(2):123–136
- Kempf A, Greiner-Mai E, Schneider J, Korn-Wendisch F, Kutzner HJ (1987) A group of actinophages of *Faenia rectivirgula*. *Curr Microbiol* 15(5):283–285
- Khan MR, Williams ST (1975) Studies on the ecology of actinomycetes in soil-VIII: distribution and characteristics of acidophilic actinomycetes. *Soil Biol Biochem* 7(6):345–348
- Kikuchi M, Perlman D (1977) Bacteriophages infecting *Micromonospora purpurea*. *J Antibiot* 30(5):423–424

- Klaus S, Triebel H, Hartmann M et al (1979) Molecular characterization of the genomes of actinophages SH3, SH10, SH11, and SH12 infecting *Streptomyces hygroscopicus*. *Mol Gen Genet* 172(3):319–327
- Klaus S, Krügel H, Süss F, Neigenfind M, Zimmermann I, Taubeneck U (1981) Properties of the temperate actinophage SH10. *Microbiology* 123(2):269–279
- Klausen C, Nicolaisen MH, Strobel BW, Warnecke F, Nielsen JL, Jørgensen NO (2005) Abundance of actinobacteria and production of geosmin and 2-methylisoborneol in Danish streams and fish ponds. *FEMS Microbiol Ecol* 52(2):265–278
- Kopcakova A, Stramova Z, Kvasnova S, Godany A, Perhacova Z, Pristas P (2014) Need for database extension for reliable identification of bacteria from extreme environments using MALDI TOF mass spectrometry. *Chem Pap* 68(11):1435–1442
- Korn-Wendisch F, Schneider J (1992) Phase typing—a useful tool in actinomycete systematics. *Gene* 115(1):243–247
- Koskella B (2013) Phase-mediated selection on microbiota of a long-lived host. *Curr Biol* 23(13):1256–1260
- Koskella B, Brockhurst MA (2014) Bacteria–phase coevolution as a driver of ecological and evolutionary processes in microbial communities. *FEMS Microbiol Rev* 38(5):916–931
- Koskella B, Meaden S (2013) Understanding bacteriophage specificity in natural microbial communities. *Viruses* 5(3):806–823
- Kubiena W, Renn CE (1935) Micropedological studies of the influence of different organic compounds upon the microflora of the soil. *Zentralbl Bakteriol Parasitenkd Infektionskr Hyg Abt* 2(91):267–292
- Kurtböke DI (1996) Present role of phase typing in reliable actinomycete identification schemes. In: Locci R, Lechevalier H, Williams ST (eds) *Actinomycetes*, vol VII. Publication of the International Centre for Theoretical and Applied Ecology, Gorizia, Italy, pp 28–33
- Kurtböke DI (2003) Use of bacteriophages for the selective isolation of rare actinomycetes. In: Kurtböke DI (ed) *Selective isolation of rare actinomycetes*. Queensland Complete Printing Services, Australia, Nambour, Queensland, pp 9–54. isbn:0-646-42910-8
- Kurtböke DI (2005) Actinophages as indicators of actinomycete taxa in marine environments. *A Van Leeuw* 87(1):19–28
- Kurtböke DI (2008) ‘Chocolate mousse’ on Sunshine Coast beaches. *Microbiology Australia* 29(2):104–105
- Kurtböke DI (2009) Use of phase-battery to isolate industrially important rare actinomycetes. In: Adams HT (ed) *Contemporary trends in bacteriophage research*. NOVA Science Publishers, New York, pp 119–149
- Kurtböke DI (2011) Exploitation of phase battery in the search for bioactive actinomycetes. *Appl Microbiol Biotechnol* 89(4):931–937
- Kurtböke DI (2016) Actinomycetes in biodiscovery: genomic advances and new horizons. In: Gupta VK, Sharma GD, Tuohy MG, Gaur R (eds) *The handbook of microbial resources*. CAB International Publications, Oxfordshire, UK, pp 567–590
- Kurtböke DI, French JRJ (2007) Use of phase battery to investigate the actinoflora layers of termite-gut microflora. *J Appl Microbiol* 103(3):722–734
- Kurtböke DI, Williams ST (1991) Use of actinophage for selective isolation purposes: current problems. *Actinomycetes* 2(2):31–36
- Kurtböke DI, Chen C-F, Williams ST (1992) Use of polyvalent phase for reduction of streptomycetes on soil dilution plates. *J Appl Bacteriol* 72:103–111
- Kurtböke DI, Murphy NE, Sivasithamparam K (1993a) Use of bacteriophage for the selective isolation of thermophilic actinomycetes from composted eucalyptus bark. *Can J Microbiol* 39:46–51
- Kurtböke DI, Wilson CR, Sivasithamparam K (1993b) Occurrence of *Actinomadura* phase in organic mulches used for avocado plantations in Western Australia. *Can J Microbiol* 39:389–394
- Kurtböke DI, French JRJ, Hayes RA, Quinn R (2015) Eco-taxonomic insights into actinomycete symbionts of termites for discovery of novel bioactive compounds. *Adv Biochem Eng Biotechnol* 147:111–135

- Küster E (1970) Notes on the taxonomy and ecology of *S. malachiticus* and related species. In: Prauser H (ed) *The actinomycetales*. VEB Gustav Fisher Verlag, Jena, pp 169–172
- Küster E (1976) Ecology and predominance of soil streptomycetes. In: Arai T (ed) *Actinomycetes; the boundary microorganisms*. Toppan Co., Tokyo, pp 109–121
- Kutzner HJ (1961) Specificity of actinophages within a selected group of *Streptomyces*. *Pathobiology* 24(2):170–191
- Lacey J (1988) Actinomycetes as biodeteriogens and pollutants of the environment. In: Goodfellow M, Williams ST, Mordarski M (eds) *Actinomycetes in biotechnology*. Academic Press, London, pp 359–432
- Lamilla C, Pavez M, Santos A, Hermosilla A, Llanquino V, Barrientos L (2016) Bioprospecting for extracellular enzymes from culturable Actinobacteria from the South Shetland Islands, Antarctica. *Polar Biol* 40:719–726. doi:10.1007/s00300-016-1977-z
- LeBlanc JC, Goncalves ER, Mohn WW (2008) Global response to desiccation stress in the soil actinomycete *Rhodococcus jostii* RHA1. *Appl Environ Microbiol* 74(9):2627–2636
- Lechevalier H (1974) Distribution et rôle des actinomycètes dans les eaux. *Bull Inst Pasteur* 72:159–175
- Lechevalier MP (1981) Ecological associations involving actinomycetes. In: Schaal K, Pulverer G (eds) *Actinomycetes*, Zbl Bakt Suppl. 11. Gustav Fisher Verlag, Stuttgart, New York, pp 159–166
- Lechevalier MP (1988) Actinomycetes in agriculture and forestry. In: Goodfellow M, Williams ST, Mordarski M (eds) *Actinomycetes in biotechnology*. Academic Press, London, pp 327–358
- Lee YK, Lee JH, Lee HK (2001) Microbial symbiosis in marine sponges. *J Microbiol*, Seoul, Korea 39(4):254–264
- Lewin A, Wentzel A, Valla S (2013) Metagenomics of microbial life in extreme temperature environments. *Curr Opin Biotechnol* 24(3):516–525
- Li WJ, Zhang YQ, Schumann P et al (2006) *Kocuria aegyptia* sp. nov., a novel actinobacterium isolated from a saline, alkaline desert soil in Egypt. *Int J Syst Evol Microbiol* 56(4):733–737
- Liu J, Hua ZS, Chen LX et al (2014) Correlating microbial diversity patterns with geochemistry in an extreme and heterogeneous environment of mine tailings. *Appl Environ Microbiol* 80(12):3677–3686
- Lloyd AB (1969) Dispersal of streptomycetes in air. *Microbiologica* 57(1):35–40
- Lomovskaya ND, Mkrumian NM, Gostimskaya NL, Danilenko VN (1972) Characterization of temperate actinophage  $\phi$ C31 isolated from *Streptomyces coelicolor* A3 (2). *J Virol* 9(2):258–262
- López-García P, Moreira D (2008) Tracking microbial biodiversity through molecular and genomic ecology. *Res Microbiol* 159(1):67–73
- Lundberg DS, Lebeis SL, Paredes SH et al (2012) Defining the core *Arabidopsis thaliana* root microbiome. *Nature* 488(7409):86–90
- Luscombe BM, Gray TRG (1974) Characteristics of *Arthrobacter* grown in continuous culture. *Microbiologica* 82(2):213–222
- Maldonado LA, Fenical W, Jensen PR, Kauffman CA, Mincer TJ, Ward AC, Bull AT, Goodfellow M (2005) *Salinispora arenicola* gen. nov., sp. nov. and *Salinispora tropica* sp. nov., obligate marine actinomycetes belonging to the family Micromonosporaceae. *Int J Syst Evol Microbiol* 55(5):1759–1766
- Marsh P, Wellington EMH (1994) Phase-host interactions in soil. *FEMS Microbiol Ecol* 15(1-2):99–107
- Martin JP, Filip Z, Haider K (1976) Effect of montmorillonite and humate on growth and metabolic activity of some actinomycetes. *Soil Biol Biochem* 8(5):409–413
- Mayfield CI, Williams ST, Ruddick SM, Hatfield HL (1972) Studies on the ecology of actinomycetes in soil IV. Observations on the form and growth of streptomycetes in soil. *Soil Biol Biochem* 4(1):79–86
- McCarthy AJ, Williams ST (1992) Actinomycetes as agents of biodegradation in the environment—a review. *Gene* 115(1-2):189–192

- McKay AC, Ophel KM, Reardon TB, Gooden JM (1993) Livestock deaths associated with *Clavibacter toxicus*/*Anguina* sp. infection in seedheads of *Agrostis avenacea* and *Polypogon monspeliensis*. *Plant Dis* 77(6):635–641
- Mckenna F, El-Tarabily KA, Hardy GESJ, Dell B (2001) Novel in vivo use of a polyvalent *Streptomyces* phase to disinfect *Streptomyces* scabies-infected seed potatoes. *Plant Pathol* 50:666–675
- McVeigh HP, Munro J, Embley TM (1996) Molecular evidence for the presence of novel actinomycete lineages in a temperate forest soil. *J Ind Microbiol* 17(3-4):197–204
- Meaden S, Koskella B (2013) Exploring the risks of phase application in the environment. *Front Microbiol* 4:358
- Metcalfe AC, Krsek M, Gooday GW et al (2002) Molecular analysis of a bacterial chitinolytic community in an upland pasture. *Appl Environ Microbiol* 68(10):5042–5050
- Meyertons JL, Tilley BC, Lechevalier MP, Lechevalier HA (1987) Actinophages and restriction enzymes from *Micromonospora* species (Actinomycetales). *J Industrial Microbiol* 2(5):293–303
- Mikami Y, Miyashita K, Arai T (1982) Diaminopimelic acid profiles of alkalophilic and alkaline-resistant strains of actinomycetes. *Microbiologica* 128(8):1709–1712
- Mincer TJ, Jensen PR, Kauffman CA, Fenical W (2002) Widespread and persistent populations of a major new marine actinomycete taxon in ocean sediments. *Appl Environ Microbiol* 68:5005–5011
- Mitri S, Foster KR (2013) The genotypic view of social interactions in microbial communities. *Annu Rev Genet* 47:247–273
- Naganuma T, Miyoshi T, Kimura H (2007) Phylotype diversity of deep-sea hydrothermal vent prokaryotes trapped by 0.2- and 0.1- $\mu$ m-pore-size filters. *Extremophiles* 11(4):637–646
- Nesterenko OA, Kasumova SA, Kvasnikov EI (1977) Microorganisms of the genus *Nocardia* and the “rhodochrous” group in the soils of the Ukrainian SSR. *Mikrobiologiya* 47(5):866–870
- Nolan RD, Cross T (1988) Isolation and screening of actinomycetes. In: Goodfellow M, Williams ST, Mordarski M (eds) *Actinomycetes in biotechnology*. Academic Press, London, pp 1–32
- Ogiso H, Seishi A (1999) Identification of two types of actinophages parasitic to potato common scab pathogens in Hokkaido, Japan. *土と微生物* 53(1):37–43
- Okoro CK, Brown R, Jones AL, Andrews BA, Asenjo JA, Goodfellow M, Bull AT (2009) Diversity of culturable actinomycetes in hyper-arid soils of the Atacama Desert, Chile. *A Van Leeuw* 95(2):121–133
- Ophel KM, Bird AF, Kerr A (1993) Association of bacteriophage particles with toxin production by *Clavibacter toxicus*, the causal agent of annual ryegrass toxicity. *Phytopathology* 83(6):676–681
- Oravec O, Nyirő G, Márialigeti K (2002) A molecular approach in the analysis of the faecal bacterial community in an African millipede belonging to the family Spirostreptidae (Diplopoda). *Eur J Soil Biol* 38(1):67–70
- Orchard V (1981) The ecology of *Nocardia* and related taxa. *Zentralblatt für Bakteriologie, Parasitenkunde, Infektionskrankheiten und Hygiene, Abteilung I, Supplement* 6:429–434
- Ordoñez OF, Flores MR, Dib JR, Paz A, Farías ME (2009) Extremophile culture collection from Andean lakes: extreme pristine environments that host a wide diversity of microorganisms with tolerance to UV radiation. *Microb Ecol* 58(3):461–473
- Parekh S, Vinci VA, Strobel RJ (2000) Improvement of microbial strains and fermentation processes. *Appl Microbiol Biotechnol* 54(3):287–301
- Pathom-Aree W, Stach JEM, Ward AC, Horikoshi K, Bull AT, Goodfellow M (2006) Diversity of actinomycetes isolated from Challenger Deep sediment (10,898 m) from the Mariana Trench. *Extremophiles* 10(3):181–189
- Patten KM, Lindsay D, Kurtböke DI (1994) Isolation of *Dermatophilus congolensis* phase from the “Lumpy Wool” of sheep. *Lett Appl Microbiol* 20:199–203
- Pedulla ML, Ford ME, Houtz JM et al (2003) Origins of highly mosaic mycobacteriophage genomes. *Cell* 113(2):171–182

- Penn K, Jenkins C, Nett M et al (2009) Genomic islands link secondary metabolism to functional adaptation in marine Actinobacteria. *The ISME Journal* 3(10):1193–1203
- Petrovski S, Dyson ZA, Quill ES et al (2011) An examination of the mechanisms for stable foam formation in activated sludge systems. *Water Res* 45(5):2146–2154
- Petrovski S, Tillett D, Seviour RJ (2012) 0 Genome sequences and characterization of the related *Gordonia* phages GTE5 and GRU1 and their use as potential biocontrol agents. *Appl Environ Microbiol* 78(1):42–47
- Phelan VV, Liu W-T, Pogliano K, Dorrestein PC (2011) Microbial metabolic exchange—the chemotype-to-phenotype link. *Nat Chem Biol* 8(1):26–35. doi:10.1038/nchembio.739
- Pontarp M, Sjöstedt J, Lundberg P (2013) Experimentally induced habitat filtering in marine bacterial communities. *Mar Ecol Prog Ser* 477:77–86
- Poulsen M, Cafaro M, Boomsma JJ, Currie CR (2005) Specificity of the mutualistic association between actinomycete bacteria and two sympatric species of *Acromyrmex* leaf-cutting ants. *Mol Ecol* 14(11):3597–3604
- Prauser H (1970) Application of actinophages on taxonomy of Actinomycetales. *Publ Fac Sci Univ J E Purkyne Brno K47*:123–126
- Prauser H (1984) Phase host ranges in the classification and identification of gram-positive branched and related bacteria. In: Ortiz-Ortiz L, Bojalil LF, Yakoleff V (eds) *Biological, biochemical, and biomedical aspects of actinomycetes*. Academic Press, Orlando, pp 617–633
- Prauser H, Falta R (1968) Phase sensitivity, cell wall composition and taxonomy of actinomycetes. *Zeitschrift für allgemeine Mikrobiologie* 8(1):39–46
- Pringsulaka O, Chavanich S, Doi K, Ogata S (2002) Changes in the population of a wide host range actinophage isolated from Thai Soil and host streptomycetes in Thai and Japanese soil. *Actinomycetologica* 16(2):21–25
- Ramette A (2007) Multivariate analyses in microbial ecology. *FEMS Microbiol Ecol* 62(2):142–160
- Ramette A, Tiedje JM (2007) Biogeography: an emerging cornerstone for understanding prokaryotic diversity, ecology, and evolution. *Microb Ecol* 53(2):197–207
- Rautenstein J (1967) Use of actinophages for the classification of Actinomycetales. *Int J Syst Evol Microbiol* 17(2):157–163
- Reilly HC, Harris DA, Waksman SA (1947) An actinophage for *Streptomyces griseus*. *J Bacteriol* 54(4):451–466
- Rheims H, Stackebrandt E (1999) Application of nested polymerase chain reaction for the detection of as yet uncultured organisms of the class Actinobacteria in environmental samples. *Environ Microbiol* 1(2):137–143
- Rheims H, Felske A, Seufert S, Stackebrandt E (1999) Molecular monitoring of an uncultured group of the class Actinobacteria in two terrestrial environments. *J Microbiol Methods* 36(1):65–75
- Riesenfeld CS, Schloss PD, Handelsman J (2004) Metagenomics: genomic analysis of microbial communities. *Annu Rev Genet* 38:525–552
- Riley IT, Gooden JM (1991) Bacteriophage specific for the *Clavibacter* sp. associated with annual ryegrass toxicity. *Lett Appl Microbiol* 12(5):158–160
- Riverin M, Beaudoin J, Vezina C (1970) Characterization of a nocardioophage for *Nocardia restrictus*. *J Gen Virol* 6(3):395–407
- Robinson JB, Corke CT (1959) Preliminary studies on the distribution of actinophages in soil. *Can J Microbiol* 5(5):479–484
- Rowbotham TJ, Cross T (1977) Ecology of *Rhodococcus coprophilus* and associated actinomycetes in fresh water and agricultural habitats. *J Gen Microbiol* 100:231–240
- Ruddick SM, Williams ST (1972) Studies on the ecology of actinomycetes in soil V. Some factors influencing the dispersal and adsorption of spores in soil. *Soil Biol Biochem* 4(1):93–103
- Saiz-Jimenez C, Groth I (1999) Actinomycetes in hypogean environments. *Geomicrobiol J* 16(1):1–8
- Salifu SP, Valero-Rello A, Campbell SA et al (2013) Genome and proteome analysis of phase E3 infecting the soil-borne actinomycete *Rhodococcus equi*. *Environ Microbiol Rep* 5(1):170–178

- Santoro M, Cappellari L, Giordano W, Banchio E (2015) Production of volatile organic compounds in PGPR. In: Cassán FD, Okon Y, Creus, CM (eds) Handbook for Azospirillum. Springer International Publishing, pp 307–317
- Schaal KP, Bickenbach H (1978) Soil occurrence of pathogenic nocardiae. Zentralblatt für Bakteriologie, Parasitenkunde, Infektionskrankheiten und Hygiene, Abteilung I, Supplement 6:429–434
- Schmitz JE, Schuch R, Fischetti VA (2010) Identifying active phase lysins through functional viral metagenomics. *Appl Environ Microbiol* 76(21):7181–7187
- Secilia J, Bagyaraj DJ (1987) Bacteria and actinomycetes associated with pot cultures of vesicular-arbuscular mycorrhizas. *Can J Microbiol* 33(12):1069–1073
- Shirai M, Nara H, Sato A, Aida T, Takahashi H (1991) Site-specific integration of the actinophage R4 genome into the chromosome of *Streptomyces parvulus* upon lysogenization. *J Bacteriol* 173(13):4237–4239
- Smith JJ, Tow LA, Stafford W, Cary C, Cowan DA (2006) Bacterial diversity in three different Antarctic cold desert mineral soils. *Microb Ecol* 51(4):413–421
- Soddell JA, Seviour RJ (1990) Microbiology of foaming in activated sludge plants. *J Appl Bacteriol* 69(2):145–176
- Souza-Egipsy V, González-Toril E, Zettler E et al (2008) Prokaryotic community structure in algal photosynthetic biofilms from extreme acidic streams in Río Tinto (Huelva, Spain). *Int Microbiol* 11:251–260
- Stach JE, Maldonado LA, Ward AC, Goodfellow M, Bull AT (2003) New primers for the class Actinobacteria: application to marine and terrestrial environments. *Environ Microbiol* 5(10):828–841
- Starkey RL (1938) Some influences of the development of higher plants upon the microorganisms in the soil. VI. Microscopic examination of the rhizosphere. *Soil Sci* 45:207–249
- Stevens H, Brinkhoff T, Rink B, Vollmers J, Simon M (2007) Diversity and abundance of Gram positive bacteria in a tidal flat ecosystem. *Environ Microbiol* 9(7):1810–1822
- Stone MJ, Williams DH (1992) On the evolution of functional secondary metabolites (natural products). *Mol Microbiol* 6(1):29–34
- Suenaga H, Ohnuki T, Miyazaki K (2007) Functional screening of a metagenomic library for genes involved in microbial degradation of aromatic compounds. *Environ Microbiol* 9(9):2289–2297
- Svircev AM, Lehman SM, Sholberg P, Roach D, Castle AJ (2011) Phase biopesticides and soil bacteria: multilayered and complex interactions. In: Witzany G (ed) *Biocommunication in soil microorganisms*. Springer Berlin, Heidelberg, pp 215–235
- Taber WA (1960) Evidence for the existence of acid-sensitive actinomycetes in soil. *Can J Microbiol* 6(5):503–514
- Tanida S, Hasegawa T, Higashide E, Yoneda M (1984) Motile cells of *Actinosynnema pretiosum* subsp. *auranticum*, a rare actinomycete. *J Gen Appl Microbiol* 30:461–467
- Teske A, Hinrichs KU, Edgcomb V, de Vera Gomez A, Kysela D, Sylva SP, Sogin ML, Jannasch HW (2002) Microbial diversity of hydrothermal sediments in the Guaymas Basin: evidence for anaerobic methanotrophic communities. *Appl Environ Microbiol* 68(4):1994–2007
- Thomas JA, Soddell JA, Kurtböke DI (2002) Fighting foam with phages? *Water Sci Technol* 46(1-2):511–518
- Thornburg CC, Zabriskie TM, McPhail KL (2010) Deep-Sea Hydrothermal Vents: Potential Hot Spots for Natural Products Discovery? *J Nat Prod* 73(3):489–499
- Tiwari K, Gupta RK (2012) Rare actinomycetes: a potential storehouse for novel antibiotics. *Cr Rev Biotechnol* 32(2):108–132
- Urbano SB, Albarracín VH, Ordoñez OF, Farías ME, Alvarez HM (2013) Lipid storage in high-altitude Andean Lakes extremophiles and its mobilization under stress conditions in *Rhodococcus* sp. A5, a UV-resistant actinobacterium. *Extremophiles* 17(2):217–227
- Wagner PL, Waldor MK (2002) Bacteriophage control of bacterial virulence. *Infect Immun* 70(8):3985–3993



- Waksman SA, Woodruff HB (1940) Bacteriostatic and bacteriocidal substances produced by soil actinomycetes. *Proc Soc Exp Biol Med* 45:609–614
- Waldrop MP, Balser TC, Firestone MK (2000) Linking microbial community composition to function in a tropical soil. *Soil Biol Biochem* 32(13):1837–1846
- Wang C, Dong D, Wang H, Müller K, Qin Y, Wang H, Wu W (2016) Metagenomic analysis of microbial consortia enriched from compost: new insights into the role of Actinobacteria in lignocellulose decomposition. *Biotechnol Biofuels* 9:22. doi:[10.1186/s13068-016-0440-2](https://doi.org/10.1186/s13068-016-0440-2)
- Weinbauer MG, Rassoulzadegan F (2004) Are viruses driving microbial diversification and diversity? *Environ Microbiol* 6(1):1–11
- Wietz M, Millán-Aguíñaga N, Jensen PR (2014) CRISPR-Cas systems in the marine actinomycete *Salinispora*: linkages with phase defense, microdiversity and biogeography. *BMC Genomics* 15(1):936
- Williams ST (1986) Actinomycete ecology—a critical evaluation. In: Szabo G, Biro S, Goodfellow M (eds) *Biological, biochemical and biomedical aspects of actinomycetes*. Kiado Press, Budapest, pp 693–700
- Williams ST, Mayfield CI (1971) Studies on the ecology of actinomycetes in soil III. The behaviour of neutrophilic streptomycetes in acid soil. *Soil Biol Biochem* 3(3):197–208
- Williams ST, Robinson CS (1981) The role of streptomycetes in decomposition of chitin in acidic soils. *Microbiologica* 127(1):55–63
- Williams ST, Wellington EMH, Tipler LS (1980) The taxonomic implications of the reactions of representative *Nocardia* strains to actinophage. *Microbiologica* 119(1):173–178
- Williams ST, Locci R, Beswick A, Kurtböke DI, Kuznetsov VD, Le Monnier FJ, Long PF, Maycroft KA, Palmit RA, Petrolini B, Quaroni S, Todd JI, West M (1993) Detection and identification of novel actinomycetes. *Res Microbiol* 144:653–656
- Willoughby LG (1976) Actinomycetes and actinophage in fresh water. In: 44th Annual Report for the year ended 31st March 1976. Ambleside, UK, Freshwater Biological Association
- Willoughby LG, Smith SM, Bradshaw RM (1972) Actinomycete virus in fresh water. *Freshw Biol* 2(1):19–26
- Wu L, Kellogg L, Devol AH, Tiedje JM, Zhou J (2008) Microarray-based characterization of microbial community functional structure and heterogeneity in marine sediments from the Gulf of Mexico. *Appl Environ Microbiol* 74(14):4516–4529
- Yamaguchi N, Ichijo T, Sakotani A, Baba T, Nasu M (2012) Global dispersion of bacterial cells on Asian dust. *Sci Report* 2:525. doi:[10.1038/srep00525](https://doi.org/10.1038/srep00525)
- Żaczek M, Weber-Dabrowska B, Górski A (2015) Phages in the global fruit and vegetable industry. *J Appl Microbiol* 118:537–556
- Zahran HH (1997) Diversity, adaptation and activity of the bacterial flora in saline environments. *Biol Fertil Soils* 25(3):211–223
- Zaitlin B, Watson SB (2006) Actinomycetes in relation to taste and odour in drinking water: myths, tenets and truths. *Water Res*, 9 40:1741–1753
- Zhang QC, Shamsi IH, DT X et al (2012) Chemical fertilizer and organic manure inputs in soil exhibit a vice versa pattern of microbial community structure. *Appl Soil Ecol* 57:1–8
- Zhu H, Sandiford SK, van Wezel GP (2014) Triggers and cues that activate antibiotic production by actinomycetes. *J Ind Microbiol Biotechnol* 41:371–386

Olga Genilloud

---

## 7.1 Introduction

Actinomycetes are saprophytic bacteria largely distributed in terrestrial and marine natural ecosystems that are able to colonize a broad diversity of substrates in a constantly changing physical and chemical environment. This group of bacteria has evolved to quickly adapt to these environmental changes and the competition from other microorganisms both in nutrient-rich and oligotrophic environments playing a key role in soil ecology. Most of the studies and interest in this group of bacteria have been focused for decades in their rich secondary metabolism and their ability to produce bioactive molecules with a broad range of applications in human health and biotechnology. The physiology and development of actinomycetes, the regulation of their primary metabolism, and the production of industrially important secondary metabolites have been extensively reviewed in the literature (Bibb 2005; Drew and Demain 1977; Dyson 2011; Hodgson 2000; Martín and Demain 1980; Van Wezel and McDowall 2011).

From an ecological perspective, actinomycetes and especially streptomycetes present unique metabolic capacities, and they are able to exploit from their soil and aquatic environments complex nutrient sources given their ability to scavenge nutrients from an environment that is frequently limiting in carbohydrates and nitrogen and phosphorous poor. Actinomycetes play an important role in the carbon and nitrogen turnover decomposing organic matter. They secrete extracellular enzymes such as cellulases, chitinases, lipases, amylases, and proteases that hydrolyze a wide range of polysaccharides and insoluble complex organic polymers (Chater et al. 2010). The broad range of regulated carbohydrate catabolic pathways found in

---

O. Genilloud

Fundación MEDINA Centro de Excelencia en Investigación de Medicamentos Innovadores en Andalucía, Av del Conocimiento, 34, 18016 Granada, Spain  
e-mail: [olga.genilloud@medinaandalucia.es](mailto:olga.genilloud@medinaandalucia.es)

actinomycetes to respond to the diversity of carbon sources and to compete and survive in the soil environment reflects the complexity of their primary metabolism. This regulation and the production of multiple bioactive secondary metabolites used to communicate or to fight competitors enable a species to survive in an environment dominated by other bacteria, fungi, insects, and nematodes. Whereas the production and regulation of secondary metabolites have been extensively studied in different species of actinomycetes, the primary metabolism pathways that involve catabolic and anabolic reactions leading to the synthesis of building blocks of proteins, nucleic acids, lipids, and structural polysaccharides have not been studied in most of the genera (Hodgson 2000). The processes related to primary metabolism ensure an increase in biomass and production of storage materials and are critical to explain the physiology and the nutritional requirements of these bacteria, as well as their role in the environment in connection with secondary metabolism. This chapter will focus on a general review of the main processes involved in actinomycetes primary metabolism and their links with secondary metabolism and does not pretend to cover exhaustively all the research performed in recent decades in the field. An important number of model strains of streptomycetes or industrially relevant secondary metabolites producers from other genera have been the subject of intensive studies, but still today there is limited knowledge about the physiological processes that govern the life cycle and primary metabolism of most families of actinomycetes, leaving this field of research open for exploration for a broad diversity of new microbial sources.

---

## 7.2 Growth Requirements

Actinomycetes exhibit a saprophytic lifestyle and can produce a large diversity of extracellular enzymes to digest complex polymeric substrates and import the resulting monomers and oligomers to be used for biomass generation and development of a primary substrate mycelium. As saprophytic degraders, actinomycetes have a mycelial lifestyle and grow as a filamentous mycelium with the ability to adhere and penetrate the surface of insoluble organic material derived from plants, fungi, and other organisms. The different families of extracellular hydrolyzing enzymes are key to ensure to the cell the supply of materials as nutrients for catabolism and anabolism. Actinomycetes have been reported to grow on the broadest diversity of nutrient sources, including in strict oligotrophic conditions (Williams 1985). They have been described to use simple sources of carbon and nitrogen sources, and a number of autotrophic species have been identified among moderate thermophiles (Bell et al. 1987; Gadkari et al. 1990). They present a complex life cycle involving differentiation stages associated to the sustained primary growth and mycelium development frequently coupled to the production of secondary metabolites. The primary substrate mycelium develops initially from the original spores or propagules extending as branching hyphae that ensure growth on the surface and within the matrix of the different substrates (Chater 1993; Goodfellow and Williams 1983). This hyphal colonization permits the access to the nutrients released by extracellular enzymes. When essential

nutrients become depleted, actinomycetes initiate a complex developmental program involving a colony differentiation characteristic of each taxonomic group that may range from the development of an aerial mycelium bearing single spores or spore chains of diverse morphology to more complex sporulating structures. Part of the mycelium is used as part of the developmental program to release nutrients required by the sporulation process (Manteca and Sanchez 2009). This differentiation is frequently associated to the production of tightly regulated secondary metabolites (Chater 1993; Takano 2006). Given the variability of their natural habitat, it has been proposed that *Streptomyces* spp. can also adapt to growth in oxygen-limiting or microaerophilic conditions. When submerged in standing liquid culture with a steep oxygen gradient, the hyphae may be growing under near anaerobic conditions (van Keulen et al. 2003). The genome sequence of *S. coelicolor* contains three operons that putatively encode a typical four-subunit respiratory nitrate reductase, a protein involved in anaerobic metabolism, suggesting that *S. coelicolor* possesses enzymes to accommodate metabolism under anoxic or microaerobic conditions, as do pathogenic actinomycetes such as corynebacteria and mycobacteria.

### 7.2.1 Carbon Sources

There is a wide range of carbohydrate substrates in the environment that can be used by actinomycetes. To respond to the diversity of carbon sources, actinomycetes can induce multiple carbohydrate catabolic pathways and secrete extracellular hydrolytic enzyme complexes to degrade insoluble polymers and get access to lower molecular weight utilizable compounds. There is a coordinated control involving both the induction and the carbon catabolite repression to regulate the synthesis of these hydrolytic enzyme complexes.

#### 7.2.1.1 Carbohydrate-Degrading Enzymes

The **extracellular polysaccharide-degrading enzymes** produced by actinomycetes include  $\alpha$ -amylases,  $\alpha$ -glucanases, cellulases, xylanases, chitinases, mannanases, and agarases. They catalyze the cleavage of complex carbohydrates into simpler units and are induced by a broad diversity of complex substrates (Chater et al. 2010; Hodgson 2000). Cellulose is the most abundant organic substrate, and it normally occurs in nature as a complex with hemicellulose containing xylan and lignin. Actinomycetes and especially *Streptomyces* play a key role in cellulose degradation and produce a complex of inducible degrading enzymes containing endoglucanases and exoglucanases, cellobiases, xylanases, and ligninases. In many cases, complex polysaccharides and breakdown products that can be transported in to the cell have been observed as the most efficient inducing agents of catabolic pathways and permeases of the compounds generated by the degrading enzymes. Although the specific responses and regulations observed are very variable and dependent on the strains, many cellulases can be repressed by glucose, cellobiose, or glycerol (Butler et al. 1999; Godden et al. 1989), whereas permeases are frequently repressed by amino acids. Different *Streptomyces* species produce inducible

endoxyylanases that can decompose xylan, a complex 1,4-linked xylose polysaccharide commonly containing side branches of arabinosyl, glucuronosyl, acetyl, uronyl, and mannosyl residues, into xylose units, and xylan degradation components can also be modified by other xylanases (Arhin et al. 1994; Johnson et al. 1988; MacKenzie et al. 1987).

Extracellular  $\alpha$ -amylases hydrolyze dextran in starch by catalyzing the cleavage of the  $\alpha$ -1,4 linkage between glucose units. Most of these enzymes are transcriptionally induced by starch or by maltose, although in *Streptomyces* species and some of them have been shown to be induced by maltose, maltotriose, and maltopentaose (Bahri and Ward 1990). These enzymes are transcriptionally repressed not only by glucose, glycerol, and mannitol but also by amino acids such as aspartate, arginine, and alanine (Grafe et al. 1986; Virolle et al. 1988).

The insoluble polysaccharide chitin is a major nutrient source for actinomycetes that are good degraders of chitins from insect exoskeletons, fungal cell walls, and marine invertebrates. They produce inducible endo- and exo-chitinases that hydrolyze  $\beta$ -1,4-linked acetylglucosamine residues. These enzymes are induced by chitin and repressed by glucose as shown in *S. lividans* (Chater et al. 2010; Robbins et al. 1992). Similarly inducible agarases and mannanases permit to degrade agar and mannans. The degradation products of this complex galactose polysaccharide can induce the enzyme production that is also repressed by glucose (Bibb et al. 1987). Endomannanases can degrade mannans releasing mannose, mannobiose, and mannotriose. Actinomycetes have been described to contain many other inducible disaccharide-degrading enzymes such as maltase,  $\beta$ -glucosidases, or  $\beta$ -galactosidases (Chater et al. 2010; Chatterjee and Vining 1981; King and Chater 1986).

### 7.2.1.2 Carbohydrate Uptake

Carbohydrate specific uptake systems for oligo and mono saccharides derived from the action of hydrolytic enzymes are mediated by multiple transport systems. Only in *S. coelicolor*, up to 54 potential carbohydrate uptake systems have been identified. They correspond to ABC permeases that can transport cellobiose, cellotriose,  $\alpha$ -glucosides, lactose, maltose, maltodextrins, ribose, xylose, and  $\beta$ -xylosides (Bertram et al. 2004). Both inducible and constitutive carbohydrate uptake systems have been described in *Streptomyces* species. The inducible carbohydrate systems are generally induced by the substrate, with affinities in the  $\mu$ M range similarly to those observed in other bacteria, whereas the constitutive transport systems show  $10^3$ -fold lower affinities. Glucose has also been shown to repress a number of inducible transport systems and inhibit a number of constitutive transport systems.

In bacteria, glucose is transported in the cell by a phosphoenolpyruvate-dependent phosphotransferase system (PTS) that only uses phosphoenolpyruvate as the phosphoryl donor and translocates sugar substrates into the cytoplasm with coordinated phosphorylations (Saier and Reizer 1994). Whereas *S. coelicolor* has a complete PTS system, glucose transport is mediated instead by a permease, the major facilitator superfamily transporter GlcP, with a preference in the utilization of N-acetylglucosamine (van Wezel et al. 2005). In fact, *S. coelicolor* lacks an orthologue of the catabolite control protein CcpA found in Gram-negative bacteria

(Piette et al. 2005), and glucose kinase plays an essential role in carbon catabolite repression (CCR). It has been proposed that glucose kinase would bind to the GlcP transporter and be released during transport of glucose (van Wezel et al. 2007). Mutants lacking a functional glucose kinase gene cannot grow on glucose and are deregulated in glucose repression of several genes under carbon catabolite repression. Glucose kinase converts glucose into glucose-6-phosphate which can enter as substrate among others in the glycolytic, the Entner-Doudoroff and the pentose phosphate pathways. The activity of glucose kinase depends on the carbon source and the growth phases (van Wezel et al. 2007). Furthermore, a study on the effect of amino acids on the uptake of glucose by *Micromonospora echinospora* has shown that the presence of amino acids reduce the uptake of glucose in complex media (Hoskisson et al. 2003). These results point to an intrinsic link between carbon and nitrogen metabolism and the possibility that a common intermediary such as 2-oxoglutarate plays a central role in this phenomenon. Whereas a membrane-bound phosphoenolpyruvate-dependent phosphotransferase system has not been found for glucose transport, there is evidence of a PEP phosphotransferase for fructose in different *Streptomyces* species (Brückner and Titgemeyer 2002; Titgemeyer et al. 1995).

The transport of disaccharides in different *Streptomyces* species involves ABC permeases as previously shown with maltose, cellobiose, and xylobiose (Schloesser et al. 1997; van Wezel et al. 1997). In *S. lividans*, the MsiK protein assists ABC transport systems and is induced by cellobiose and other disaccharides. The maltose-induced and glucose-repressed maltose transport systems *malEFG* from *S. coelicolor* are repressed by MalR. Repressor mutants present a constitutive expression of *malEFG* and loss of glucose repression (van Wezel et al. 1997). Similarly the MarR homologue Reg1 is required in *S. lividans* to repress the amylase and chitinase genes, and loss of the regulator leads to constitutive expression of the extracellular enzymes and lack of repression by glucose (Nguyen et al. 1997).

## 7.2.2 Nitrogen Sources

Soil is a nitrogen-poor environment, and nitrogen needs to be retrieved efficiently when it becomes available from nutrient-limiting environments. Actinomycetes require nitrogen to ensure biomass production as well as to synthesize a large diversity of secondary metabolites from amino acids that are used as key precursors. For this purpose these bacteria have developed a complex system to regulate nitrogen metabolism that permits to respond to the different environmental conditions and synthesize the essential enzymes involved in its efficient assimilation. Large part of their genome is devoted to the synthesis of hydrolytic enzymes to process macromolecules and convert these components in glutamine and glutamate.

### 7.2.2.1 Proteases and Peptidases and Amino Acid Transport

A large diversity of extracellular proteases and peptidases are produced by actinomycetes as complexes with hydrolytic activities including serinproteases, elastase, zinc-containing metalloendopeptidases, leucine peptidase, aminopeptidase,

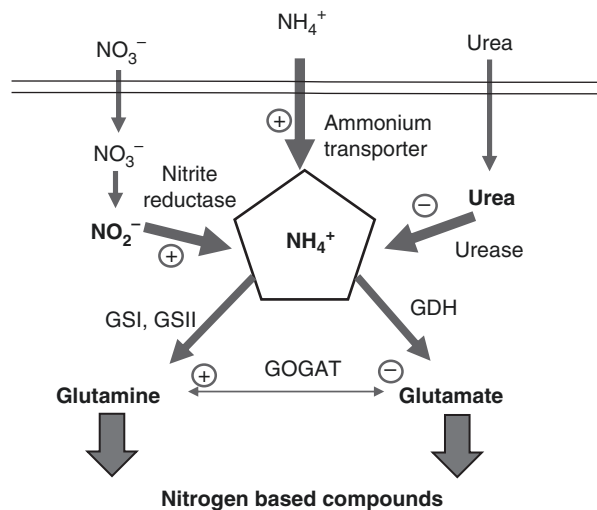
and carboxypeptidases (Chater et al. 2010; Pokorny et al. 1979; Tsuyuki et al. 1991). Extracellular proteases are involved in assimilating extracellular protein-derived nitrogen sources, but there is evidence of some extracellular proteases having a role in *Streptomyces* development (Chater et al. 2010). These proteins are synthesized as pre-proteins, and they are exported and activated after autocleavage of the signal peptide (Chang et al. 1990). Proteases are subject to different control in their regulation, including induction by protein catabolites and catabolite repression in the presence of ammonium or some free amino acids (Shin and Lee 1986) or a constitutive expression regulated by the growth rate and carbon and nitrogen catabolite repression. The production of extracellular aminopeptidases and carboxypeptidases has been reported in different *Streptomyces* species at the onset of the stationary phase, correlating the exhaustion of carbon sources (Uwajima et al. 1973). Other studies have shown an inhibition by amino acids suggesting a feedback by peptide cleavage products (Vosbeck et al. 1978). The constitutive extracellular metalloprotease from *S. clavuligerus* is only suppressed at high growth rates or by ammonium, suggesting both a role of stringent response and of nitrogen catabolite repression (Bascaran et al. 1990). The production of some aminopeptidases and endoproteases is also associated in *S. lividans*, as well as in *S. spheroids* and *S. aureofaciens*, to the glucose depletion in late exponential growth, suggesting a glucose repression of the complex (Aretz et al. 1989; Laluce and Molinari 1977). In *S. aureofaciens* the production of protease activity was directly dependent on the ratio between carbon and nitrogen sources (Laluce and Molinari 1977).

Some studies have focused on the peptide transport system in actinomycetes and have shown the existence of oligopeptide permeases in *S. coelicolor* A3(2) in mutants defective of aerial mycelium formation. The study of the bialaphos-resistant *bldK* mutants has identified a bialaphos transport system consisting of an ABC transporter with homology to oligopeptide permeases (Nodwell et al. 1996). Different classes of amino acid permeases have been described in *Streptomyces* species that can transport neutral, basic, and acidic amino acids. Transport of neutral amino acids is dependent on the growth rate and growth phase and is mediated by feedback regulation of intracellular amino acid pools affecting the synthesis and the efficiency of the permease (Alim and Ring 1976). In *S. lipmanii* leucine inhibits threonine, isoleucine, and valine permeases suggesting a common permease for these four amino acids (Kirkpatrick and Godfrey 1973). Cyclic nucleotides have been shown to be involved specifically in permease induction (Ring et al. 1977a). On the contrary acidic amino acids are transported in different forms according to the pH of the medium. They can be transported in their anionic form, as is the case of aspartate and glutamate, by specific energy-dependent permeases or in their zwitterionic forms by neutral amino acid permeases at higher rates (Fritsch and Gross 1983; Gross and Ring 1971). Basic amino acids can be transported by two energy-dependent systems, a constitutive system very specific for arginine and an inducible system transporting both arginine and lysine (Gross and Burkhardt 1973).

### 7.2.2.2 Sources of Ammonium and Ammonium Assimilation

Ammonium is one of the preferred nitrogen sources for actinomycetes that can be obtained mainly from the catabolism of amino acids as major sources, as well as from nitrate and urea. Glutamate and glutamine are key intermediates in the assimilation of ammonium and key nitrogen donors. These two amino acids receive their nitrogen atoms by two pathways, the glutamine synthetase/glutamate synthetase (GS/GOGAT) pathway and the glutamate dehydrogenase (GDH) pathway. The high ammonium affinity glutamine synthetase (GS) is used in nitrogen-limiting conditions to introduce ammonium in the metabolism whereas the low affinity glutamate dehydrogenase (GDH) is normally used in conditions of high nitrogen supply. The glutamine synthetase/glutamate synthetase (GS/GOGAT) pathway includes the key enzymes in bacterial nitrogen metabolism and in ammonium assimilation. GS produces glutamine from glutamate plus ammonia whereas GOGAT removes the amide group from glutamine and transfers it to  $\alpha$ -ketoglutarate to yield two glutamate molecules. In fact glutamine synthetases play a dual role both in nitrogen assimilation and L-glutamine synthesis (Sanchez and Demain 2002; Tyler 1978) (Fig. 7.1).

The nitrogen metabolism in *Streptomyces* is regulated by complex mechanisms where two different glutamine synthetase enzymes have been identified. Glutamine synthetase type I (GSI), the major GS occurring in prokaryotes, is encoded by the gene *glnA* (Wray and Fischer 1998; Hillemann et al. 1993). Glutamine synthetase type II (GSII), similar to eukaryotic GSs and encoded by the gene *glnII*, resembles plant GSII enzymes that were first described in the nitrogen-fixing bacteria *Rhizobium* and *Frankia*. Genome sequencing has revealed that *Streptomyces*, as well as many other actinobacteria, contains additional *glnA*-type genes shown to be nonfunctional. On the contrary the gene *glnII* is absent in strains of *Mycobacterium* and *Corynebacterium* (Behrmann et al. 1990; Harth et al. 2005; Reuther and



**Fig. 7.1** N metabolism in *S. coelicolor* (adapted from Wohlleben et al. 2011). Transcription is repressed (-) or stimulated (+) in response to nitrogen supply



Wohlleben 2007). In *S. coelicolor* both GS activities have been shown to be functional, although GSI ensures the major activity during vegetative growth. Whereas some GSII protein activity is observed in late growth phase and nitrogen-limiting conditions, the function of this eukaryotic-like GS is still unclear in *Streptomyces*, and they have not been detected in other related actinomycetes (Reuther and Wohlleben 2007).

Nitrogen metabolism in streptomycetes presents a complex regulation involving transcriptional and posttranslational regulatory steps in coordination with other primary metabolism processes that permit to respond to the variable external conditions. GSI and GSII are differentially regulated in *Streptomyces*. The nitrogen regulation of GSI in *S. coelicolor* is common to other bacteria. In response to excess of ammonium, GSI is inactivated by adenylation by the adenylyltransferase GlnE (Fink et al. 1999; Jiang and Ninfa 2009). Contrary to what is observed in other bacteria, GlnE is not under control of the uridylyltransferase/uridylyl-removing enzyme GlnD and the proteins GlnB and GlnK that belong to the P<sub>II</sub> signal transduction superfamily and are orthologues of the bacterial nitrogen-sensing proteins as part of the nitrogen regulation system (Atkinson and Ninfa 1998; Merrick and Edwards 1995). Different *Streptomyces* species (*S. cattleya*, *S. clavuligerus*, *S. coelicolor*, and *S. viridochromogenes*) show this posttranslational modification of GSI that has been proposed to be required to protect the intracellular pool of glutamate in conditions of ammonium excess (Wohlleben et al. 2011) and to avoid general repressive effects on secondary metabolite biosynthesis due to high ammonium concentrations in the growth medium. On the contrary, in conditions of nitrogen limitation, *glnA* is constitutively expressed throughout the developmental cycle, whereas *glnII* transcription increases upon morphological differentiation. The transcriptional expression level of several nitrogen metabolism genes is under control of the OmpR-like regulators GlnR and Gln RII that operate as modulators of gene expression (Fink et al. 2002). The global nitrogen activator/repressor GlnR controls all important routes for ammonium assimilation. In response to nitrogen limitation, GlnR activates the transcription of *glnA* and *glnII* encoding both GS in *S. coelicolor* as well as the transporter gene *amtB* and the putative nitrite reductase gene *nirB*. GlnR orthologues have also been identified from genome sequence analysis in other actinobacteria which show 60–80% homology to the *S. coelicolor* GlnR (Tiffert et al. 2008). Microarray studies have suggested that there might be a connection between the phosphate control exerted by PhoP and the overall nitrogen regulation mediated by GlnR (Rodríguez-García et al. 2007).

A global analysis of GlnR-DNA interactions in *Streptomyces venezuelae* using the ChIP on chip technology revealed that some potential targets of GlnR might be involved in pathways other than the nitrogen metabolism, including carbon metabolism, such as the TCA cycle, glycolysis pathway, and the pentose phosphate pathway (Pullan et al. 2011; Tiffert et al. 2011). Transcription of the *agl3* operon, encoding a putative ABC-type carbohydrate transporter and repressed by Agl3R, a GlnR-related regulator, is also directly negatively regulated by GlnR, providing a direct evidence for the close relationship between carbon and nitrogen metabolisms (Cen et al. 2016).

As previously mentioned, *Streptomyces* can also utilize nitrate and urea as source of nitrogen (Fig. 7.1). *S. venezuelae* has a nitrate reductase activity that is only used when ammonium is depleted (Shapiro and Vining 1984) and that is inhibited by L-histidine and L-asparagine as was reported in *S. cyanoviridis*. Under oxygen-limited conditions, actinomycetes can also denitrify nitrate to generate N<sub>2</sub>O and nitric oxide (Albrecht et al. 1997). The urease activity hydrolyzing urea into ammonium and carbon dioxide is regulated by the global nitrogen regulation and is suppressed in conditions of high ammonium supply (Bascaran et al. 1989).

### 7.2.3 Phosphorus Uptake and Regulation

Phosphorus is an essential component for bacterial growth and one of the major cell constituents, playing an important role in cell metabolism and as constituent of most cell macromolecules (Santos-Beneit et al. 2008). The preferred source of phosphorus in bacteria is inorganic phosphate (P<sub>i</sub>), which can enter the cell using at least two different transport systems, the high-affinity phosphate-specific ABC transporter Pst and the low-affinity phosphate inorganic transporter Pit. Phosphate metabolism in *Streptomyces* is under control of the *pho* regulon and modulated by the two-component signal transduction system PhoR-PhoP that promotes adaptation to low P<sub>i</sub> by increasing phosphate uptake and/or utilization of cellular polyphosphate reserves (Sola-Landa et al. 2003). The membrane protein kinase PhoR senses phosphate limitations, and the response regulator PhoP binds to DNA to control transcription of the *pho* regulon genes controlling genes involved both in primary and secondary metabolism.

The high-affinity phosphate-specific ABC transporter Pst is composed of four proteins encoded by the *pstSCAB* operon and included in the PHO regulon: the periplasmic phosphate-binding protein PstS, the integral membrane proteins PstA and PstC, and the ATP-binding subunit PstB (Rao and Torriani 1990). The low-affinity phosphate inorganic transporter Pit is a fast phosphate-uptake system dependent on the proton motive force. Whereas in *E. coli* the transmembrane protein Pit is the major P<sub>i</sub> uptake system when P<sub>i</sub> is in excess (Elvin et al. 1986; Rosenberg et al. 1977, 1979), *S. coelicolor* presents three P<sub>i</sub> transport systems (Pst, PitH1 and PitH2) with differential regulation. Pst and PitH2 work when P<sub>i</sub> is limited whereas PitH1 is the major transporter when P<sub>i</sub> is in excess. The *S. coelicolor* *pit* genes are clustered with distinct accessory genes and can also be classified according to their regulation. In *S. coelicolor* the expression of the *pstS* gene is under strict phosphate control (Díaz et al. 2005; Sola-Landa et al. 2005). Transcription of *pitH2* gene is also PhoP dependent, while *pitH1* is not (Santos-Beneit et al. 2008).

To survive P<sub>i</sub> starvation, *Streptomyces* can consume phosphorous from storage polyphosphates, nucleotides, and teichoic acids that need to be hydrolyzed before being transported in the cell (Martín and Demain 1980). Phosphate deprivation triggers the PHO regulon, and the production of extracellular enzymes involved in phosphate scavenging from organic phosphates. *S. coelicolor* contains at least four phosphatases, a phytase, and two glycerophosphodiester phosphodiesterase systems to hydrolyze

different organic phosphates (Apel et al. 2007; Rodríguez-García et al. 2007; Sola-Landa et al. 2008). The utilization of cellular polyphosphate reserves is mediated by polyphosphate kinase (PPK), an enzyme catalyzing the reversible polymerization of the  $\gamma$  phosphate of ATP into polyphosphate when the ATP/ADP ratio is high. The expression of the *ppk* gene in *S. lividans* is upregulated by the PhoP response regulator in  $P_i$ -limiting conditions. On the contrary, when the ATP/ADP ratio decreases, ATP can be generated from polyphosphate by PPK. In fact it has been suggested that in limiting polyphosphate conditions, upregulation of central carbon metabolism would respond to the low ATP/ADP ratio to generate ATP. When this takes place at the end of exponential growth, the products (reduced cofactors, ATP, carbon catabolites) could be derived to be used in the biosynthesis of secondary metabolites. PhoP-binding sites have also been found in gene clusters associated to the biosynthesis of cell wall polysaccharides (Ghorbel et al. 2006; Rodríguez-García et al. 2007).

Carbon and phosphate sources interact through several metabolic pathways, with different molecules being used as sensors of the intracellular C/P ratio. In *S. coelicolor* the level of extracellular phosphate-binding protein PstS responds to both phosphate limitation (Rodríguez-García et al. 2007; Sola-Landa et al. 2005) and carbon sources such as fructose or glucose (Díaz et al. 2005).

Phosphate control of many *pho* regulon genes is mediated by binding of PhoP to PHO operators formed by direct repeat units of 11 nucleotides. Transcriptomic studies have shown that several genes involved in nitrogen metabolism are regulated by phosphate (Rodríguez-García et al. 2007). PhoP binds to the *glnR* promoter, encoding GlnR, the major nitrogen regulator in *S. coelicolor*, but not to the *glnRII* promoter, suggesting a nitrogen regulatory system independent of PhoP. PhoP also binds to the promoters of *glnA* and *glnRII* encoding two glutamine synthetases and to the promoter of the *amtB-glnK-glnD* operon, encoding an ammonium transporter and two putative nitrogen-sensing/regulatory proteins. Expression from these promoter regions is drastically increased in a  $\Delta$ *phoP* mutant, demonstrating that they are repressed by PhoP (Rodríguez-García et al. 2009). A response to phosphate limitation, mediated by an increased PhoP level, is to reduce expression of genes involved in nitrogen utilization. The PhoP-negative control on nitrogen assimilation genes in phosphate-limiting conditions has been suggested as a way to utilize cell resources to obtain phosphate from the medium. The nitrogen source and phosphate regulatory networks interact in *Streptomyces* to provide an adaptation to nutritional changes and ensure a fine coordination of the utilization of the available nitrogen and phosphate sources.

---

### 7.3 Primary Metabolism

The main role of primary metabolism is to sustain growth and the synthesis of biomass. In actinomycetes, the regulation of primary metabolism reflects the nutrient-limited conditions of the environment and the adaptation of these saprophytic bacteria to survive in nutrient-limited conditions, with well-coordinated carbohydrate and nitrogen catabolic systems permitting the efficient utilization of the resources in soil.

### 7.3.1 Carbohydrate Catabolism

Actinomycetes primary metabolism is complex and characterized by the presence of multiple isoenzymes involved in single catalytic steps of glycolysis, the pentose phosphate and TCA cycle pathways. Isoenzymes are encoded by similar or homologous gene products, and although some pathways show a tight clustering of genes in operons, as found with the glycerol or trehalose pathways, normally the different gene copies of the central carbon metabolism do not cluster in operons as observed in other bacteria where primary metabolism pathways have a coordinated regulation of gene expression (van Keulen et al. 2011). Genes are scattered in the chromosome, and two or more isoenzymes can present different regulation depending on the carbon sources or the development stage. When glucose is available, utilization of other carbon sources is prevented, whereas in the absence of glucose, amino acids are then used as carbon source, providing Acyl-CoA for fatty acid synthesis. This differential regulation would permit to modulate a more complex carbon metabolism distributing fluxes through different pathways (Moore et al. 2002).

In *Streptomyces* the glycolytic enzyme glucose kinase converts glucose to glucose-6-phosphate (G6P) that can enter following different pathways as substrate of the glucose phosphate isomerase, the glucose-6-phosphate dehydrogenase, the pentose phosphate pathway, and the glucose-6-phosphatase (Fig. 7.2). Glucose-6-phosphatase also plays a role in carbon catabolite repression (CCR), an activity that is independent of the kinase activity.

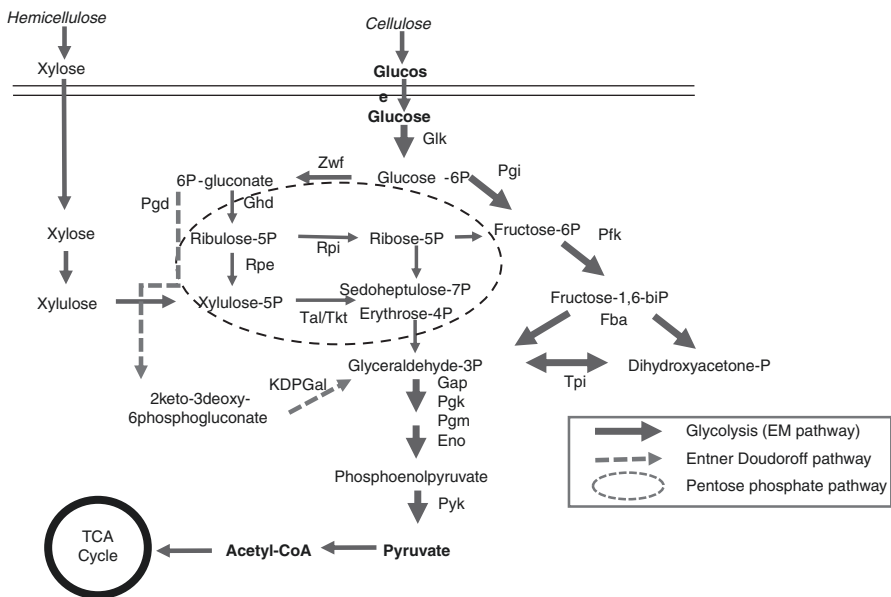


Fig. 7.2 Main pathways of carbohydrate catabolism

In the case of the glucose metabolism, the Embden-Meyerhof (EM) pathway is the most important glycolytic pathway as it is used to generate ATP and provide precursors for secondary metabolism. The EM pathway is regulated at the level of the glycolytic enzyme phosphofructokinase (Pfk), and in *S. coelicolor* only one of the three Pfk isoenzymes that present high sequence similarity has been shown to be important in glycolysis (Alves et al. 1997). The content of homologous Pfk enzymes is variable depending on the *Streptomyces* species studied and apparently have different specific functions (van Keulen et al. 2011). The Pfk of *S. coelicolor* belongs to the family A group III with no or limited allosteric regulation and is also found in other actinomycetes (*Amycolatopsis methanolica*, *Propionibacterium*, *Frankia*). Actinomycetes can differ in the phosphoryl donor, and several species of *Salinispora tropica*, *Saccharopolyspora erythraea*, or *Thermobifida fusca* produce PPI-dependent phosphofructokinases, whereas in *Rhodococcus jostii* or *Corynebacterium glutamicum*, they are ATP dependent (van Keulen et al. 2011). Similarly only one of the two isoforms of the glyceraldehyde-3-phosphate dehydrogenase is expressed in primary metabolism in *S. arenae* (Hodgson 2000). Contrary to the majority of bacteria that use the EM pathways or the hexose monophosphate shunt, streptomycetes cannot grow anaerobically on glucose and are obligate aerobes (Albrecht et al. 1997).

Actinomycetes can also metabolize glucose via glycolysis and the pentose phosphate pathway (PPP) (Gunnarsson et al. 2004). It has been observed that in glucose-grown cells of different *Streptomyces* species, an increase in growth rate parallels an increased flux of the PPP that disappears when growth is prevented. These results have suggested that the main role of the PPP is the generation of biomass precursors (Borodina et al. 2008).

The Entner-Doudoroff (ED) pathway is unusual in actinomycetes, but it has been shown to be active in several actinomycetes such as *Nonomuraea* or *S. tenebrarius* (Borodina et al. 2005; Gunnarsson et al. 2004). Furthermore, the genomes of *Saccharopolyspora erythraea*, *Rhodococcus jostii*, *Saccharomonospora viridis*, *Actinosynnema mirum*, and *Nocardioopsis dassonvillei* have been found to contain homologues of 6-phosphogluconate dehydratase gene. On the contrary an active ED pathway was not observed in *S. coelicolor*, *S. avermitilis*, *S. scabies*, and *S. griseus*.

Streptomycetes can grow on acetate or aliphatic compounds, reactions that provide TCA intermediates for the synthesis of amino acids. The tricarboxylic acid cycle is active and complete in *Streptomyces* and essential in the supply of precursors to secondary metabolism. Citrate synthase is inhibited by ATP and induced by AMP, but NAD has no effect on its activity. In streptomycetes a PEP carboxylase is involved in oxaloacetate formation. The enzyme is stimulated by acetyl-CoA, whereas it is inhibited by nucleoside triphosphates, succinate, aspartate, and citrate (Vorisek et al. 1969). Several isozymes of malate dehydrogenase have been described with differential response to oxaloacetate. Some of the strains use acetate poorly and lack the enzymes malate synthase and citrate lyase (Dekleva and Strohl 1988). The lack of isocitrate lyase required an alternative route to glyoxylate, and glyoxylate biosynthetic pathway was proposed from the identification of two genes essential for acetate utilization and encoding the crotonyl-coenzyme A reductase (ccr) and a vitamin B12-dependent mutase (meaA)

(Han and Reynolds 1997). The two pathways synthesize glyoxylate from acetyl-CoA and require propionyl-CoA carboxylase (Bramwell et al. 1996).

In addition many anaplerotic enzymes can play an important role shuffling intermediates from the TCA cycle and the EM pathway in the absence of glycolytic carbon sources. *S. coelicolor* can grow on glutamine or asparagine as sole carbon sources, and the complete gluconeogenic pathway has been found in genomes of *S. avermitilis*, *S. coelicolor*, and *S. griseus* (Borodina et al. 2005). The enzyme malate dehydrogenase, normally used to generate NADPH for fatty acid synthesis, is repressed in *Streptomyces* in the presence of acetate and is only active in exponential growth paralleling the fatty acid synthesis, (Behal et al. 1969). The ability to grow on pyruvate or alanine on sole carbon source is due to the pyruvate phosphate dikinase activity that allows the interconversion of pyruvate into PEP, an enzyme that is induced by pyruvate or alanine. Some actinomycetes can secrete pyruvate and TCA intermediates to the medium when grown on glucose probably as a result from the imbalance between glycolysis and the TCA cycle. This secretion has been reported in some *Streptomyces* species growing both in exponential phase and entering the stationary phase (Dekleva and Strohl 1988).

Actinomycetes catabolize other carbohydrate sources following different specific pathways. Galactose catabolism is regulated by the products of the galactose operon galTEK in *S. lividans* that encodes a galactose-1-phosphate uridylyltransferase (GalT), a UDP-galactose-4-epimerase (GalE), and a galactose kinase (GalK) (Adams et al. 1988). The operon is under the control of both a galactose-inducible and glucose-repressed promoter as well as a constitutive promoter (Brawner et al. 1997). The requirement of galactose-1-phosphate and UDP-galactose for galactosyl lipid biosynthesis suggests the dual anabolic and catabolic role of both GalE and GalK. In the case of xylose, xylose isomerase is the first enzyme of xylose metabolism in *Streptomyces* interconverting xylose and xylulose. The enzyme also has a glucose isomerase activity converting glucose and fructose. This enzyme has been extensively studied in different species given its applications in food industry (Dauter et al. 1989). Two genes of the xylose catabolism pathway, the xylose isomerase gene *xylA* and the xylulose kinase gene *xylB*, are induced by xylose and repressed by glucose in different extension (Wong et al. 1991). The regulation of *xylA* has been studied in many species and shown to be inducible by xylose or xylan. Streptomycetes metabolize glycerol using a glycerol-inducible pathway involving a glycerol transport system repressed by glucose (GylC), a glycerol kinase (GylA), and a glycerol-3-phosphate dehydrogenase (GylB), and a repressor GylR encoding upstream of the operon (Biro and Chater 1987; Seno and Chater 1983)

### 7.3.2 Carbon Catabolite Repression and Stringent Response

Carbon catabolite repression (CCR) is exerted on extracellular and intracellular catabolic enzymes and ensures that the cell can use preferentially the different carbon sources available. Carbon catabolite repression is a global control system in streptomycetes and includes repression by glucose and other monosaccharides.

In most bacteria, the phosphoenolpyruvate-dependent phosphotransferase system (PTS) plays a major role in CCR, and PTS-mediated transport activates the cAMP-receptor protein or the catabolite control protein of Gram-negative or low-GC Gram-positive bacteria, respectively (Brückner and Titgemeyer 2002). In streptomycetes, glucose transport is mediated by the major facilitator superfamily transporter GlcP, and glucose stimulates glycolysis as well as the pentose phosphate pathway (van Wezel et al. 2005) and until recently CCR has been considered to be totally mediated by the glycolytic enzyme glucose kinase. Glucose kinase not only converts glucose to glucose-6-phosphate but also plays a key role in CCR, an effect independent of the glucose kinase activity and the flux of glucose. The ATP-dependent glucose kinase belongs to the group III family of glucose kinases that contain a ROK (Repressor of Kinases) signature found in diverse families of proteins (Titgemeyer et al. 1994). Glucose kinase is produced constitutively in *S. coelicolor* but the enzymatic activity is also dependent on the growth phase and carbon source (van Wezel et al. 2007). Mutants lacking glucose kinase are unable to grow on glucose as sole carbon source and present no glucose regulation in several carbon catabolite regulated genes (van Wezel et al. 2007). More recently, advanced proteomics analysis of a glucose kinase mutant has permitted to identify a second pathway for carbon control of primary metabolism independent of glucose kinase. It has been shown that if glucose kinase mainly mediates CCR for enzymes involved in primary and secondary metabolism and precursors for natural product synthesis, other pathways such as the enzymes of the urea cycle or the biosynthesis of  $\gamma$ -butyrolactone are under control of a glucose kinase-independent CCR, proposing a new model for CCR in streptomycetes (Gubbens et al. 2012). In fact, it was found that pyruvate phosphate dikinase involved in the production of PEP from pyruvate is massively repressed by glucose in a glucose kinase-independent action. Enzymes involved in amino acid metabolism and transport were strongly downregulated by glucose in the glucose kinase mutant. One of the proteins more intensively repressed was SCO0977, an enzyme that belongs to the family of signaling *N*-acetyltransferases involved in Acyl-CoA-dependent transfer. Furthermore, contrary to other sugar and amino acid transporters repressed as expected by glucose and dependent on glucose kinase, the xylose transporter was activated by glucose independently of glucose kinase.

Another regulatory point in *Streptomyces* metabolism is related to the morphological and metabolic differentiation and the stringent response that is normally triggered by nutrient limitation and cessation of growth. Most streptomycetes present a classic stringent response, and starvation for amino acids leads to an intracellular accumulation of ppGpp and pppGpp, nucleotides that are responsible for the inactivation of transcription of mRNAs, tRNAs, and other ribosomal operons, which is translated into a transient cessation of growth. In starvation conditions, RelA is activated by the binding of uncharged tRNAs to the ribosome under conditions of nitrogen and amino acid starvation inducing the production of (p)ppGpp by RelA from GTP and ATP. The level of (p)ppGpp is determined by the balance of two related activities, a pyrophosphokinase (or synthetase) and a

pyrophosphohydrolase. SpoT produces (p)ppGpp in response to several nutrient stresses, such as carbon, phosphate, iron, and fatty acid starvation. An increase of nucleotide ppGpp causes dramatic changes in the physiology, and stringent response enhances transcription of genes associated with growth, secondary metabolism, adaptation, survival, persistence, cell division, motility, development, and virulence (Potrykus and Cashel 2008). The exact mechanism by which ppGpp operates upon such a large number of genes needs to be clarified in close connection with secondary metabolism (Hesketh et al. 2007).

### 7.3.3 Carbon Storage Compounds

Different carbohydrates such as glycogen, trehalose, or triacylglycerols have been identified as carbon storage compounds. Glycogen has been reported to accumulate as reserve in the mycelium and the spores of different *Streptomyces* species, and its use has been related to the different development stages of the cells. The presence of glycogen was confirmed in *S. viridochromogenes* (A27) during the formation of the septa in aerial hyphae disappearing after spore maturation (Brana et al. 1982). Glycogen accumulation was demonstrated in the substrate mycelium at the onset of the aerial mycelium development, with reserves being used as the aerial mycelium was developed (Mendez et al. 1985). The analysis of the glycogen synthetic genes revealed two biosynthetic systems encoding isoenzymes operating in different cell development stages as shown for *S. coelicolor* A3(2) and *S. aureofaciens* (Homerova et al. 1996; Martin et al. 1977). Trehalose is a disaccharide found in the substrate mycelium of all *Streptomyces* that is synthesized from GDP-D-glucose and glucose-6-phosphate, contrary to what is found in insects and fungi that use as donor UDP-D-glucose (Elbein 1968; McBride and Ensign 1987). This disaccharide is cleaved by a trehalase to release glucose. The trehalase activity increased after spore germination whereas the trehalose phosphate synthase activity increased with cell mass production, supporting the role of the trehalose as carbon and energy storage in spores (Hey-Ferguson et al. 1973).

### 7.3.4 Nitrogen Metabolism

Together with carbon catabolite repression, nitrogen catabolite repression controls a large number of amino acid catabolism systems. Carbon catabolite repression is a global control system in streptomycetes and includes repression by glucose and other monosaccharides but does not play a large role in controlling amino acid metabolism as in other bacteria. In contrast, nitrogen catabolite repression plays a key role in control of primary metabolism. It has been shown in *S. clavuligerus* that glutamine synthetase, urease, or arginine catabolic enzymes are subject to ammonium repression whereas the enzymes involved in serine, proline, or histidine catabolism are not (Bascaran et al. 1990).



### 7.3.4.1 Amino Acid Catabolism

Different routes are followed to catabolize the families of amino acids introduced by permeases upon action of the extracellular proteases. Tryptophan is a precursor of NAD<sup>+</sup> biosynthesis in *S. antibioticus* as well as some secondary metabolites such as actinomycin D and streptonigrin and is catabolized in all studied streptomycetes. Most of the strains accumulate anthranilate and formyl-anthranilate as a result of this catabolism that proceeds via formyl-kynurenine to generate in two steps hydroxyl-anthranilate (Katz et al. 1984). Two isoenzymes have been identified for kynurenine formamidase, the second stage of the pathway. The first one is expressed constitutively in low levels and may be responsible of the NAD synthesis, and the second is induced during the production of actinomycin D. The metabolism of phenylalanine and tyrosine differs according to the strains studied. Phenylalanine ammonia-lyase has been shown to be responsible of the non-oxidative deamination to cinnamate in *S. verticillatus* (Emes and Vining 1970), whereas in *S. setoni* both phenylalanine and tyrosine can be completely metabolized via homogentisate. Tyrosinase also plays a role in the tyrosine metabolism to form melanin. Histidine can be processed via formyl glutamic acid. Histidases from *S. griseus* and *S. coelicolor* are regulated at posttranslational level and are inactivated by adenylation, whereas they are activated by urocanate, an activator of phosphorylated activator factor (Kroening and Kendrick 1989). Additionally, a histidine aminotransferase has been identified in *S. tendae* capable of transferring an amino group to pyruvate to form alanine. Proline catabolism involves a proline oxidase and a pyrroline-5-carboxylate dehydrogenase to form glutamate (Smith et al. 1995). Arginine is precursor of many secondary metabolites, and in *S. clavuligerus* it can be degraded by arginase and ornithine aminotransferase to glutamate and urea via ornithine and pyrroline-5-carboxylate. In *S. griseus*, arginine can be used both as carbon and nitrogen source to form aminobutyrate and succinate. Another route for arginine catabolism in streptomycin producing strains involves an amidinotransferase to form ornithine (Walker and Hnilica 1964). Branched amino acid catabolism proceeds via intermediates that are precursors of many secondary metabolites (Reynolds et al. 1988). Valine dehydrogenase is the first enzyme of the pathway and is responsible of the deamination of all the branched-chain amino acids valine, leucine, and isoleucine. This enzyme is induced at different levels by all three branched amino acids but is also subject to glucose repression and, as observed when cultured in the absence of valine, to suppression of activity by increasing concentration of ammonium (Vancura et al. 1987). The second enzyme in the pathway is an  $\alpha$ -keto acid dehydrogenase responsible of the oxidative decarboxylation of the branched-chain 2-oxo acid. The enzyme is induced by isovaline and repressed by ammonium (Lounes et al. 1995). Aspartate can be used as sole nitrogen source in *S. fradiae* given that it contains a glutamate:oxaloacetate transaminase (Lee and Lee 1993). Asparagine is hydrolyzed by asparaginase into aspartate and ammonium. The enzyme is subject to catabolite repression, whereas both asparagine and in less extent glutamine can operate as inducers (Mostafa 1979). Threonine is metabolized by threonine dehydratase and threonine aldolase (Vancura et al. 1988). Threonine dehydratase catalyzes the deamination to  $\alpha$ -ketobutyrate in many streptomycetes, a

precursor of propionate, and in *S. fradiae* is induced by the amino acid. Threonine aldolase is another catabolic enzyme and catalyzes the splitting into glycine and acetaldehyde that may be converted to acetyl-CoA.

Lysine is a precursor of many important secondary metabolites such as  $\beta$ -lactams (Kern et al. 1980), and its catabolism usually follows the cadaverine pathway to finally generate glutarate (Fothergill and Guest 1977) that is catabolized via glutaryl-CoA and the fatty acid degradation pathway. Cadaverine aminotransferase is the second enzyme of the pathway, and it can be found in all streptomycetes. The enzyme is induced by lysine and cadaverine and repressed by ammonium and glutamate (Madduri et al. 1989). The strains that produce  $\beta$ -lactams also contain a lysine  $\epsilon$ -aminotransferase, the first enzyme of the  $\alpha$ -amino adipate degradation, and uniquely involved in  $\beta$ -lactam biosynthesis (Madduri et al. 1989). Alanine is catabolized in some strains by deamination to form pyruvate by the alanine 2-oxoglutarate transaminase. Alternatively an alanine dehydrogenase that is found in all streptomycetes studied is also responsible of this catabolism. Ammonium and alanine can induce both enzymes in different levels according to the strains used (Novak et al. 1997). Serine dehydratase has been shown to be involved in serine metabolism in *S. clavuligerus* (Bascaran et al. 1989). The strain is unable to grow on serine as sole nitrogen source, suggesting its role in serine detoxification. There is little information about cysteine catabolism in streptomycetes, and the transsulfuration pathways could be considered a methionine catabolic pathway (Hagino and Nakayama 1968).

#### 7.3.4.2 Nucleotide Catabolism

Thymine is catabolized via  $\beta$ -aminoisobutyrate by reduction to dihydrothymine, formation of  $\beta$ -ureidoisobutyric acid, cleavage to urea and  $\beta$ -aminoisobutyrate, deamination to methylmalonyl semialdehyde, condensation to form methylmalonyl-CoA, and formation of succinyl-CoA (O'Hagan et al. 1995). In the case of purines, the salvage pathway permits their interconversion, but streptomycetes also contain several pathways of hypoxanthine oxidation to urate. The most usual intermediate is xanthine and 6,8-dihydroxypurine that can be further catabolized to urate (Ohe and Watanabe 1977). When cells enter in exponential phase, xanthine dehydrogenase is induced to ensure oxidation of hypoxanthine. Hypoxanthine can be used as sole carbon source, and the catabolic form of the pathway is proposed to release ammonium for nitrogen assimilation.

#### 7.3.4.3 Nitrogen Metabolite Biosynthesis

The shikimate pathway is responsible of the formation of chorismate, a common precursor of the aromatic amino acids tryptophan, phenylalanine, and tyrosine, as well as *p*-aminobenzoic acid, and is also precursor of NAD<sup>+</sup>. An important number of secondary metabolites are derived from intermediates of this pathway. Streptomycetes present only one form of isozyme of DAHP synthase (3-deoxy-D-arabinoheptulosonate-7-phosphate) described in bacteria for the first step of the shikimate pathway. The enzyme is regulated cooperatively by tryptophan and chorismate as shown for *S. antibioticus* (Murphy and Katz 1980). The third enzyme of the *S. coelicolor* shikimate pathway (3-dehydroquinate dehydratase) has the

characteristics of an inducible catabolic enzyme also found in fungi (White et al. 1990) and was observed as well in *S. hygrosopicus*, *Amycolatopsis methanolica*, and *Mycobacterium tuberculosis* (Euverink et al. 1992; Florova et al. 1998; Garbe et al. 1991). Chorismate is precursor of prephenate, anthranilate, and *p*-aminobenzoate. Prephenate dehydratases are insensitive to phenylalanine and tyrosine in *S. antibioticus* and *S. viridochromogenes*, whereas they are stimulated by tyrosine in *S. niveoruber* or by phenylalanine in *S. venezuelae* (Hodgson 2000). Two gene clusters are involved in the synthesis of the early and late enzymes of the tryptophan pathway in *S. coelicolor* and *S. venezuelae* (Hu et al. 1999; Paradkar et al. 1993). The anthranilate synthetase genes *trpE* and *trpG* were cloned by complementation with *trpE* and *trpG* mutants, and the whole genome sequence of *S. coelicolor* confirmed three *trpE* genes. Para-aminobenzoate is synthesized from chorismate by *p*-aminobenzoate synthetase and is a precursor of tetrahydrofolate as well as candidicin and fungimycin (Gil et al. 1985; Hodgson 2000).

The four amino acids glutamate, glutamine, arginine, and proline are members of the glutamate amino acids. Proline biosynthesis occurs from glutamate via  $\gamma$ -glutamyl phosphate, glutamate semialdehyde, and pyrroline-5-carboxylate (Hood et al. 1992). Arginine is synthesized from glutamate by initial acetylation followed by additional seven enzymatic steps and is precursor of many important molecules such as streptomycin, sinefungin, or clavulanic acid (Udaka 1966).

The metabolism of branched-chain amino acids valine, isoleucine, and leucine proceeds via intermediates of polyketide and polyether antibiotics (Reynolds et al. 1988). Isoleucine and valine are produced by the same enzymes but using different precursors:  $\alpha$ -acetolactate is used in the case of valine and the condensation of pyruvate and  $\alpha$ -ketobutyrate to form  $\alpha$ -aceto- $\alpha$ -hydroxybutyrate in the case of isoleucine. Leucine is synthesized via the isopropylmalate pathways, being the first intermediate  $\alpha$ -ketoisovalerate, a product of the valine pathway.

The aspartate family of amino acids includes aspartate, asparagine, lysine, threonine, and methionine. A number of important secondary metabolites are produced from lysine, including  $\beta$ -lactams. Lysine can be synthesized via the aminoadipate pathway or the diaminopimelate pathway. The use of the DAP pathway was confirmed in *S. griseus*, *S. venezuelae*, and *S. clavuligerus*, whereas in *S. antibioticus* and *S. lipmanii*, *S. lavendulae* used the aminoadipate pathway (Kirkpatrick and Godfrey 1973; Mendelovitz and Aharonowitz 1982; Sawada et al. 1977). The first enzymes that lead to DAP are aspartokinase and aspartate semialdehyde dehydrogenase. The product of aspartokinase is a precursor of methionine, threonine, and lysine. The stimulation of aspartokinase by lysine alone and the feedback inhibition by threonine plus lysine have been observed in several *Streptomyces* species (*S. clavuligerus*, *S. noursei*).

In the case of threonine, two enzymes, homoserine kinase and threonine synthase, are unique for its synthesis, whereas homoserine dehydrogenase is used for alanine that is synthesized from pyruvate following two reactions, a transamination by alanine:oxoglutarate transaminase (AOAT) or by an alanine dehydrogenase (ADH)-mediated condensation of ammonium with pyruvate. These enzymes are not shared by all *Streptomyces* species. *Streptomyces* with AOAT such as *S.*

*avermitilis*, *S. cyanogenus*, or *S. hygrosopicus* can generate alanine from glutamate, but other *Streptomyces* species such as *S. coelicolor* or *S. clavuligerus* only contain ADH.

Glycine is synthesized from serine by the transfer of a hydroxymethyl group from serine to tetrahydrofolate. In the case of methionine, this amino acid is synthesized by the transfer of a methyl group from methyl-tetrahydrofolate to homocysteine.

The metabolism of sulfur-containing amino acids in *Streptomyces* differs from the rest of the bacteria by the presence of enzymes of the transsulfuration pathway found in eukaryotes, allowing the transfer of sulfur from methionine to cysteine. The thiosulfate pathway involves the reduction of imported sulfur to sulfide and thiosulfate which is then condensed to O-acetylserine sulfhydrylase, to form S-sulfocysteine that is finally reduced to cysteine (Kitano et al. 1985; Nagawasa et al. 1984). The transsulfuration pathway in streptomycetes permits the interconversion of methionine in cysteine as shown in *S. clavuligerus*, *S. cattleya*, and *A. lactamdurans* (Kern and Inamine 1981). The enzyme cystathionine- $\gamma$ -lyase that cleaves L-cystathionine into cysteine is derepressed in sulfate-limited media and subjected to feedback regulation by cysteine. This enzyme is broadly distributed in many actinomycetes genera tested including *Streptomyces*, *Micromonospora*, *Micropolyspora*, and *Streptosporangium*, among others (Nagawasa et al. 1984). Another key enzyme is cystathionine  $\beta$ -synthase converting homocysteine to cystathionine. Methionine is synthesized from cystathionine and homocysteine precursors. Methionine is also a precursor of the methyl group donor S-adenosylmethionine, and once donated, S-adenosylhomocysteine can be hydrolyzed to adenosine and homocysteine, as reported in many actinomycetes, and the latter can be recycled in the synthesis of methionine (Walker and Duerre 1975).

---

## 7.4 Secondary Metabolites

In contrast to primary metabolites, secondary metabolites were defined originally as nonessential compounds produced by microorganisms not required for life maintenance and for which no apparent function could be identified. Nevertheless, the production of secondary metabolites is tightly regulated and well coordinated with the bacterial life cycle. These molecules have shown to be involved in mycelial development, to confer adaptative advantages to the survival in the environment given their bioactivity, as well as to play a role in symbiosis or microbial communication (Berdy 2005; Chater et al. 2010; Hodgson 2000).

In fact, the capacity to produce multiple secondary metabolites can reflect the selective use of some metabolites according to the primary metabolic flux and the available precursors in the cell. In laboratory conditions, these compounds are frequently produced at the end of the vegetative growth when cells enter stationary phase and develop aerial mycelium taking advantage of the nutrient released by the breakdown of vegetative hyphae. Secondary metabolites are synthesized from precursor molecules and building blocks provided by primary

metabolism, and regulation in primary metabolism is directly influencing secondary metabolism. Secondary metabolites production is dramatically affected by changes in the primary carbon and nitrogen metabolite fluxes that can increase the supply or limit the access to key precursors (Bibb 2005; Borodina et al. 2008; Olano et al. 2008; van Keulen et al. 2011; Wohlleben et al. 2011). There are numerous examples of mutants in primary glycolytic pathways affecting secondary metabolite production. These may involve the overproduction of some precursors or deletions preventing the synthesis of key metabolites of the biosynthesis of precursors of different antibiotics (Drew and Demain 1977; Sanchez and Demain 2002). The overproduction of malonyl-CoA, a common precursor of the synthesis of many polyketides, by overexpression of acetyl-CoA carboxylase, affects directly the production of these secondary metabolites as observed with actinorhodin in *S. coelicolor* (Ryu et al. 2006). The production of monensin by *S. cinnamomensis* is almost abolished by inactivation of crotonyl-CoA reductase, the enzyme that provides the precursor methylmalonyl-CoA (Li et al. 2004). The change from exponential growth phase to production phase can be paralleled by a change in the metabolic balance between the carbon flow into glycolysis and the pentose phosphate pathway, affecting the redox balance and the accumulation of other precursors (Borodina et al. 2008). RelA, the ribosome-associated ppGpp synthetase, is required for antibiotic production under conditions of nitrogen limitation as shown in *Streptomyces coelicolor* A3(2) and for cephamycin C production in *Streptomyces clavuligerus*, suggesting the direct role for ppGpp in activating the transcription of antibiotic biosynthetic genes (Hesketh et al. 2007).

From this perspective, and contrary to what we can observe in primary metabolism pathways, the genes associated to the production of secondary metabolites are frequently clustered and under the control of transcriptional regulators modulating of their expression. Clusters for secondary metabolites contain pathway-specific regulators that can include one to multiple single regulatory genes or transcription factors that directly activate transcription of biosynthetic enzymes. In addition, they can act individually or in combination as it is the case with the transcription factors ActII-ORF4 and StrR from *S. coelicolor* and *S. griseus* modulating the expression of actinorhodin and streptomycin, respectively. In the case of *S. griseus*, the transcription of the regulator is activated by a cascade of transcription activations mediated by the levels of the A-factor, a  $\gamma$ -butyrolactone that acts as a microbial hormone. The A-factor binds to the repressor of transcription ArpA and induces the transcription of AdpA, required for activation of transcription of strR, the pathway-specific regulatory gene for streptomycin production (Takano 2006; Van Wezel and McDowall 2011).  $\gamma$ -Butyrolactones are produced by many streptomycetes and by several other genera of actinomycetes, and most of them appear to be devoted to the regulation of secondary metabolism, being involved in the onset of secondary metabolism in several species. The virginiae butanolides (VB), IM-2 and SCB1, control, respectively, virginiamycin production in *Streptomyces virginiae*, showdomycin and minimycin in *Streptomyces lavendulae*, and the production of the pigmented antibiotics Act and Red in *S. coelicolor* (Takano 2006).

Many of the pathway-specific regulators belong to the SARP family (*Streptomyces* antibiotic regulatory proteins). ActII-ORF4 is the first regulator that was described with a complex regulation involving different regulators such as AbsA2, a response regulator of a two component signal transduction system that acts as negative regulator of several antibiotics produced by *S. coelicolor*. SARP regulator has been described to be associated with secondary metabolic gene clusters in *Streptomyces* as well as species of the genera *Mycobacterium*, *Nocardia*, *Thermobifida*, and *Lechevalieria* that encode aromatic polyketides (angucycline, daunorubicin, medemycin), ribosomally and non-ribosomally synthesized peptides (cinnamycin), undecylprodiginines, the type I polyketide monensin, and the  $\beta$ -lactam thienamycin.

LAL regulators (large ATP-binding members of the LuxR family) are another group of regulators related to the *E. coli* MalT from the LuxR family that have been found in many streptomycetes. LAL regulators can be found in the pikromycin cluster in *S. venezuelae*, the nystatin cluster in *S. noursei* (Brautase et al. 2000; Wilson et al. 2001), as well as in the amphotericin, candicidin, and geldanamycin clusters (Campelo and Gil 2002; Carmody et al. 2004; Rascher et al. 2003).

PtmR1 is another repressor of the biosynthesis of platensimycin and platencin identified in the platensimycin cluster in *S. platensis* (Smanski et al. 2009).

Carbon control of secondary metabolism is defined by the availability and type of carbohydrate. Secondary metabolite production is influenced by glucose and other carbohydrates not only by the extent of growth before the onset of the stringent response but also by CCR that will ensure that preferred carbon sources are used instead of other sources less favorable energetically. N-Acetylglucosamine (GlcNAc), along with glutamate, is preferred as a carbon source over glucose by *S. coelicolor*, but GlcNAc has additional effects, as it can also block the development and antibiotic production when added in rich media, whereas in minimal media these processes are accelerated (Rigali et al. 2008). DasR is another key regulator of secondary metabolite biosynthesis, and it was initially identified as a repressor of N-acetylglucosamine PTS genes that can bind to the promoter of ActII-ORF4. DasR operates as nutrient sensor and effector of metabolic changes. Its binding affinity is reduced by glucose-6P that is an intermediate of N-acetylglucosamine metabolism. The transcription factor DasR that binds to the promoters of genes involved in the metabolism and transport of GlcNAc is directly involved in sensing the levels of GlcNAc and regulating the production of antibiotics.

Numerous studies have shown that the source of nitrogen can influence the production of antibiotics that is frequently reduced by sources of nitrogen that favor growth (Sanchez and Demain 2002). The transcription of *glnR* gene that encodes the major regulator of nitrogen metabolism and other genes involved in ammonium transport and assimilation is also subjected to phosphate regulation and is repressed by PhoP (Rodríguez-García et al. 2009). In a number of biosynthetic pathways, conditions increasing amino acid formation may result in overproduction of secondary metabolites. Amino acids can function as inducers and turn on the production of secondary metabolites as it is the case of lysine for lysine- $\epsilon$ -aminotransferase in the cephamycin pathway of *Streptomyces clavuligerus* (Rius et al. 1996) or valine for

valine dehydrogenase of the tylosin process in *Streptomyces fradiae* (Nguyen et al. 1995). The level of phosphate in growth media may have a substantial effect on antibiotic production, and a high level in the culture medium prevents the production of many structurally diverse secondary metabolites and reflects repression of transcription of biosynthetic genes clusters (Martín and Demain 1980; Sola-Landa et al. 2003). This regulation is mediated by the PhoRP system that controls secondary metabolism and may be indirect, reflecting the inability to assimilate low levels of phosphate and maintain growth rate.

Similarly, disruption of zinc and iron homeostasis has been observed to influence secondary metabolism, and the effects on secondary metabolite production can be an indirect effect of the physiological stress.

---

### Conclusions

Future research in the physiology and regulation of the metabolism of *Streptomyces* spp. and other members of the actinomycetes and its influence on secondary metabolite production will benefit from the new functional genomic approaches and genome-scale metabolic analyses. These comparative approaches extended to a large number of wild-type strains will help to obtain a better insight of the global regulatory pathways that govern the interaction between primary and secondary metabolic processes among a large representation of this microbial community. With no doubts further work is required to understand what the different roles of the multiple copies of the primary metabolism genes are to respond to specific responses of the microbial cells and why different regulatory pathways have been evolved and take place specifically in individual strains.

Current knowledge accumulated from the evidence obtained from more than four decades has shown that both primary and secondary metabolism are elegantly interconnected in a complex network of regulatory signals that sense the environment and ensure the adaptation and survival in the microbial community. More comparative studies are still required to reveal common and unique trends that govern the expression and control of the metabolic pathways in a representative number of members of actinomycetes still unexplored to increase the chances of success in harnessing the extraordinary metabolic potential of these talented bacteria.

---

### References

- Adams CW, Fornwald JA, Schmidt FJ et al (1988) Gene organization and structure of the *Streptomyces lividans* gal operon. J bacterial 170:203–212
- Albrecht A, Ottow JCG, Benckiser G et al (1997) Incomplete denitrification (NO and N<sub>2</sub>O) from nitrate by *Streptomyces violaceoruber* and *S. nitrosporeus* revealed by acetylene inhibition and <sup>15</sup>N gas chromatography quadrupole mass spectrometry analyses. Naturwissenschaften 84:145–147
- Alim S, Ring K (1976) Regulation of amino acid transport in growing cells of *Streptomyces hydrogenans*. II: correlation between transport capacity and growth rate in chemostat culture. Arch Microbiol 111:105–110

- Alves AM, Euverink GJ, Bibb MJ, Dijkhuizen L (1997) Identification of ATP-dependent phosphofructokinase as a regulatory step in the glycolytic pathway of the actinomycete *Streptomyces coelicolor* A3 (2). *Appl Environ Microbiol* 63:956–961
- Apel AK, Sola-Landa A, Rodríguez-García A, Martín JF (2007) Phosphate control of *phoA*, *phoC* and *phoD* gene expression in *Streptomyces coelicolor* reveals significant differences in binding of PhoP to their promoter regions. *Microbiology* 153:3527–3537
- Aretz W, Koller KP, Riess G (1989) Proteolytic enzymes from recombinant *Streptomyces lividans* TK24. *FEMS Microbiol Lett* 65:31–36
- Arhin FF, Shareck F, Kluepfel D, Morosoli R (1994) Effects of disruption of xylanase-encoding genes on the xylanolytic system of *Streptomyces lividans*. *J Bacteriol* 176:4924–4930
- Atkinson MR, Ninfa AJ (1998) Role of GlnK signal transduction protein in the regulation of nitrogen assimilation in *Escherichia coli*. *Mol Microbiol* 29:431–447
- Bahri SM, Ward M (1990) Regulation of a thermostable  $\alpha$ -amylase of *Streptomyces thermoviolaceus* CUB74: maltotriose is the smallest inducer. *Biochimie* 72:8983–8895
- Bascaran V, Hardisson C, Brana AF (1989) Regulation of nitrogen catabolic enzymes in *Streptomyces clavuligerus*. *J Gen Microbiol* 135:2465–2474
- Bascaran V, Hardisson C, Brana AF (1990) Regulation of extracellular protease production in *Streptomyces clavuligerus*. *Appl Microbiol Biotechnol* 34:208–213
- Behal V, Cudlin J, Vanek Z (1969) Regulation of biosynthesis of secondary metabolites. *Folia Microbiol III* 14:117–120
- Behrmann I, Hillemann D, Pühler A, Strauch E, Wohlleben W (1990) Overexpression of a *Streptomyces viridochromogenes* gene (*glnII*) encoding a glutamine synthetase similar to those of eucaryotes confers resistance against the antibiotic phosphinothricyl-alanyl-alanine. *J Bacteriol* 172:5326–5334
- Bell JM, Falconer C, Colby J, Williams E (1987) CO metabolism in a thermophilic actinomycete, *Streptomyces* strains G26. *J Gen Microbiol* 133:3445–3456
- Berdy J (2005) Bioactive microbial metabolites. *J Antibiot* 58:1–26
- Bertram R, Schlicht M, Mahr K, Nothaft H, Saier MH Jr, Titgemeyer F (2004) In silico and transcriptional analysis of carbohydrate uptake systems of *Streptomyces coelicolor* A3(2). *J Bacteriol* 186:1362–1373
- Bibb MJ (2005) Regulation of secondary metabolism in Streptomycetes. *Curr Op Microbiol* 8:208–215
- Bibb MJ, Jones GH, Joseph R et al (1987) The agarase gene (*dagA*) of *Streptomyces coelicolor* A3(2): affinity purification and characterization of the cloned gene product. *J Gen Microbiol* 133:2089–2096
- Biro S, Chater KF (1987) Cloning of *Streptomyces griseus* and *Streptomyces lividans* genes for glycerol dissimilation. *Gene* 56:79–86
- Borodina I, Krabben P, Nielsen J (2005) Genome-scale analysis of *Streptomyces coelicolor* A3(2) metabolism. *Genome Res* 15:820–829
- Borodina I, Siebring J, Zhang J, Smith CP, van Keulen G, Dijkhuizen I, Nielsen J (2008) Antibiotic overproduction in *Streptomyces coelicolor* A3(2) mediated by phosphofructokinase deletion. *J Biol Chem* 283:25186–25199
- Bramwell H, Hunter IS, Coggins JR, Nimmo HG (1996) Propionyl-CoA carboxylase from *Streptomyces coelicolor* A3(2): purification of the enzyme, cloning of the *ppc* gene and overexpression of the protein in a streptomycete. *Biochem J* 293:131–136
- Brana AF, Manzanal MB, Hardisson C (1982) Characterization of intracellular polysaccharides of *Streptomyces*. *Can J Microbiol* 28:1320–1323
- Brautase T, Sekurova ON, Sletta H et al (2000) Biosynthesis of the polyene antifungal antibiotic nystatin in *Streptomyces noursei* ATCC 11455: analysis of the gene cluster and deduction of the biosynthetic pathway. *Chem Biol* 7:395–403
- Brawner ME, Matter SG, Babcock MJ, Westpheling J (1997) The *Streptomyces galP1* promoter was a novel RNA polymerase recognition sequence and is transcribed by a new RNA polymerase in vitro. *J Bacteriol* 179:3222–3231
- Brückner R, Titgemeyer F (2002) Carbon catabolite repression in bacteria: choice of the carbon source and autoregulatory limitation of sugar utilization. *FEMS Microbiol Lett* 209:141–148



- Butler MJ, Deutscher J, Postma PW, Wilson TJ, Galinier A, Bibb MJ (1999) Analysis of a ptsH homologue from *Streptomyces coelicolor* A3(2). *FEMS Microbiol Lett* 177:279–288
- Campelo AB, Gil JA (2002) The candicidin gene cluster from *Streptomyces griseus* IMRU 3570. *Microbiology* 148:51–59
- Carmody M, Byrne B, Murphy B et al (2004) Analysis and manipulation of amphotericin biosynthetic genes by means of modified phage KC515 transduction techniques. *Gene* 343:107–115
- Cen X-F, Wang J-Z, Zhao G-P et al (2016) Molecular evidence for the coordination of nitrogen and carbon metabolisms, revealed by a study on the transcriptional regulation of the agl3EFG operon that encodes a putative carbohydrate transporter in *Streptomyces coelicolor*. *Biochem Biophys Res Commun* 471:510–514
- Chang PC, Kuo TC, Tsugita A, Lee YHM (1990) Extracellular metalloprotease gene of *Streptomyces cacaoi*: structure, nucleotide sequence and characterization of the cloned gene product. *Gene* 88:87–95
- Chater KF (1993) Genetics of differentiation in *Streptomyces*. *Annu Rev Microbiol* 47:685–711
- Chater KF, Biro S, Lee KJ, Palmer T, Schrepf H (2010) The complex extracellular biology of *Streptomyces*. *FEMS Microbiol Rev* 34:171–198
- Chatterjee S, Vining LC (1981) Nutrient utilization in actinomycetes. Induction of  $\alpha$ -glucosidases in *Streptomyces venezuelae*. *Can J Microbiol* 27:639–645
- Dauter Z, Dauter M, Hemker J et al (1989) Crystallization and preliminary analysis of glucose isomerase from *Streptomyces albus*. *FEBS Lett* 247:1–8
- Dekleva ML, Strohl WR (1988) Biosynthesis of e-rhodomyconine from glucose by *Streptomyces* C5 and comparison with intermediary metabolism of other polyketide-producing streptomycetes. *Can J Microbiol* 34:1235–1240
- Díaz M, Esteban A, Fernández-Abalos JM et al (2005) The high-affinity phosphate-binding protein PstS is accumulated under high fructose concentrations and mutation of the corresponding gene affects differentiation in *Streptomyces lividans*. *Microbiology* 151:2583–2592
- Drew SW, Demain AL (1977) Effect of primary metabolism on secondary metabolism. *Annu Rev Microbiol* 31:343–356
- Dyson P (ed) (2011) *Streptomyces: molecular biology and biotechnology*. Caister Academic Press, Norfolk
- Elbein AD (1968) Trehalose phosphate synthesis in *Streptomyces hygroscopicus*: purification of guanosine diphosphate D-glucose:D-glucose-6-phosphate 1-glucosyl-transferase. *J Bacteriol* 96:1623–1631
- Elvin CM, Dixon NE, Rosenberg H (1986) Molecular cloning of the phosphate (inorganic) transport (*pit*) gene of *Escherichia coli* K12. Identification of the *pit+* gene product and physical mapping of the *pit*-*gor* region of the chromosome *Mol Gen Genet* 204:477–484
- Emes AV, Vining LC (1970) Partial purification and properties of L-phenylalanine ammonia-lyase from *Streptomyces verticillatus*. *Can J Biochem* 48:613–622
- Euverink GJW, Hessels GI, Vrijbloed JW et al (1992) Purification and characterization of a dual function 3-dehydroquinate dehydratase from *Amycolatopsis methanolica*. *J Gen Microbiol* 138:2449–2457
- Fink D, Falke D, Wohlleben W, Engels A (1999) Nitrogen metabolism in *Streptomyces coelicolor* A3(2): modification of glutamine synthetase I by an adenylyltransferase. *Microbiology* 145:2313–2322
- Fink D, Weibschuch N, Reuther J, Wohlleben W, Engels A (2002) Two transcriptional regulators GlnR and GlnRII are involved in regulation of nitrogen metabolism in *Streptomyces coelicolor* A3(2). *Mol Microbiol* 46:331–347
- Florova G, Denoya CD, Morgensten MR et al (1998) Cloning, expression and characterization of a type II 3-dehydroquinate dehydratase gene from *Streptomyces hygroscopicus*. *Arch Biochem Biophys* 350:298–306
- Fothergill JC, Guest JR (1977) Catabolism of L-Lysine by *Pseudomonas aeruginosa*. *J Gen Microbiol* 99:139–155
- Fritsch J, Gross W (1983) Studies on the transport of anions and zwitterions of acidic amino acids in *Streptomyces hydrogenans*. *Z Naturforsch* 38c:617–620

- Gadkari D, Schricker K, Acker G et al (1990) *Streptomyces thermoautotrophicus* sp. nov., a thermophilic CO<sub>2</sub>- and H<sub>2</sub>-oxidizing obligate chemolithotroph. *Appl Environ Microbiol* 56:3727–3734
- Garbe T, Servos S, Hawkins A et al (1991) The *Mycobacterium tuberculosis* shikimate pathway genes: evolutionary relationship between biosynthetic and catabolic 3-dehydroquinases. *Mol Gen Genet* 228:385–392
- Ghorbel S, Smirnov A, Chouayekh H, Sperandio B, Esnault C, Kormanec J, Virolle MJ (2006) Regulation of *ppk* expression and in vivo function of Ppk in *Streptomyces lividans* TK24. *J Bacteriol* 188:6269–6276
- Gil JA, Naharro G, Villanueva JR, Martin JF (1985) Characterization and regulation of *p*-aminobenzoic acid synthase from *Streptomyces griseus*. *J Gen Microbiol* 131:1279–1287
- Godden B, Legon T, Helvenstein P, Penninckx M (1989) Regulation of the production of hemi-cellulolytic and cellulolytic enzymes by a *Streptomyces* sp. growing on lignocellulose. *J Gen Microbiol* 135:285–292
- Goodfellow M, Williams ST (1983) Ecology of actinomycetes. *Annu Rev Microbiol* 37:189–216
- Grafe U, Bormann EJ, Roth M, Neigenfind M (1986) Mutants of *Streptomyces hygroscopicus* deregulated in amylase and  $\alpha$ -glucosidase formation. *Biotechnol Lett* 8:615–620
- Gross W, Burkhardt K-L (1973) Multiple transport systems for basic amino acid transport in *Streptomyces hydrogenans*. *Biochim Biophys Acta* 298:437–445
- Gross W, Ring K (1971) Effect of chloramphenicol on active amino acid transport. *FEBS Lett* 4:319–322
- Gubbens J, Janus M, Florea BI et al (2012) Identification of glucose kinase-dependent and—independent pathways for carbon control of primary metabolism, development and antibiotic production in *Streptomyces coelicolor* by quantitative proteomics. *Mol Microbiol* 86:1490–1507
- Gunnarsson N, Mortensen UH, Sosio M, Nielsen J (2004) Identification of the Entner-Doudoroff pathway in an antibiotic producing actinomycete species. *Mol Microbiol* 52:895–902
- Hagino H, Nakayama K (1968) Amino acid metabolism in microorganisms. IV: L-methionine decarboxylase produced by a *Streptomyces* strain. *Agric Biol Chem* 32:727–733
- Han L, Reynolds KA (1997) A novel alternate anaplerotic pathway to the glyoxylate cycle in streptomycetes. *J Bacteriol* 179:5157–5164
- Harth G, Maslesa-Galic S, Tullius MV, Horwitz MA (2005) All four *Mycobacterium tuberculosis* *glnA* genes encode glutamine synthetase activities but only GlnA1 is abundantly expressed and essential for bacterial homeostasis. *Mol Microbiol* 58:1157–1172
- Hesketh A, Chen WJ, Ryding J, Chang S, Bibb MJ (2007) The global role of ppGpp synthesis in morphological differentiation and antibiotic production in *Streptomyces coelicolor* A3(2). *Genome Biol* 8:R161
- Hey-Ferguson A, Mitchell M, Elbein AD (1973) Trehalose metabolism in germinating spores of *Streptomyces hygroscopicus*. *J Bacteriol* 116:1084–1085
- Hillemann D, Dammann T, Hillemann A, Wohlleben W (1993) Genetic and biochemical characterization of the two glutamine synthetases GSI and GSII of the phosphinothricyl-alanyl-alanine producer, *Streptomyces viridochromogenes* Tü494. *J Gen Microbiol* 139:1773–1783
- Hodgson DA (2000) primary metabolism and its control in streptomycetes: a most unusual group of bacteria. *Adv Microb Physiol* 42:47–238
- Homerova D, Benada O, Kofronova O et al (1996) Disruption of a glycogen-branching enzyme gene, *glgB*, specifically affects the sporulation-associated phase of glycogen accumulation in *Streptomyces aureofaciens*. *Microbiology* 142:1201–1208
- Hood DW, Heidstra R, Swoboda UK, Hodgson DA (1992) Molecular genetic analysis of proline and tryptophan biosynthesis in *Streptomyces coelicolor* A3(2): interaction between primary and secondary metabolism: a review. *Gene* 115:5–12
- Hoskisson PA, Sharples GP, Hobbs G (2003) The importance of amino acids as carbon sources for *Micromonospora echinospora* (ATCC 15837). *Lett Appl Microbiol* 36:268–271

- Hu DS, Hood DW, Heidstra R, Hodgson DA (1999) The expression of the *trpD*, *trpC* and *trpBA* genes in *Streptomyces coelicolor* A3(2) is regulated by growth rate and growth phase but not by feedback repression. *Mol Microbiol* 32:869–880
- Jiang P, Ninfa AJ (2009) Reconstitution of *Escherichia coli* glutamine synthetase adenylyltransferase from N-terminal and C-terminal fragments of the enzyme. *Biochemistry* 48:415–423
- Johnson KG, Harrison BA, Schneider H et al (1988) Xylan-hydrolyzing enzymes from *Streptomyces* spp. *Enzym Microb Technol* 10:403–409
- Katz E, Brown D, Hitchcock MJM et al (1984) Regulation of tryptophan metabolism and its relationship to actinomycin D synthesis. In: Ortiz-Ortiz L, Bojalil LF, Yakoleff V (eds) *Biological, biochemical and biomedical aspects of actinomycetes*. Academic Press, New York, pp 325–342
- Kern BA, Hendlin D, Inamine E (1980) L-lysine  $\epsilon$ -aminotransferase involved in cephamycin C synthesis in *Streptomyces lactamdurans*. *Antimicrob Agents Chemother* 17:679–685
- Kern BA, Inamine E (1981) Cystathionine  $\gamma$ -lyase activity in the cephamycin C producer *Streptomyces lactamdurans*. *J Antibiot* 34:583–589
- van Keulen G, Jonkers HM, Claessen D, Dijkhuizen L, Wösten HAB (2003) Differentiation and anaerobiosis in standing liquid cultures of *Streptomyces coelicolor*. *J Bacteriol* 185:1455–1458
- van Keulen G, Siebring J, Dijkhuizen L (2011) Central carbon metabolic pathways in *Streptomyces*. In: Dyson P (ed) *Streptomyces: molecular biology and biotechnology*. Caister Academic Press, Norfolk, pp 105–123
- King AA, Chater KF (1986) The expression of the *Escherichia coli* *lacZ* gene in *Streptomyces*. *J Gen Microbiol* 132:1739–1752
- Kirkpatrick JR, Godfrey OW (1973) The isolation and characterization of auxotrophs of the aspartic acid family from *Streptomyces lipmanii*. *Folia Microbiol* 18:90–101
- Kitano K, Nozaki Y, Imada A (1985) Selective accumulation of unsulfated carbapenem antibiotics by sulfate transport-negative mutants of *Streptomyces griseus* subsp. *cryophilus* C-19393. *Agric Biol Chem* 49:677–684
- Kroening TA, Kendrick KE (1989) Cascading regulation of histidine ammonia-lyase activity from *Streptomyces griseus*. *J Bacteriol* 171:1100–1105
- Laluce C, Molinari R (1977) Selection of a chemically defined medium for submerged cultivation of *Streptomyces aureofaciens* with high extracellular caseinolytic activity. *Biotechnol Bioeng* 19:1863–1884
- Lee SH, Lee KJ (1993) Aspartate aminotransferase and tylosin biosynthesis in *Streptomyces fradiae*. *Appl Environ Microbiol* 59:822–827
- Li CX, Florova G, Akopiants K, Reynolds KA (2004) Crotonyl-coenzyme A reductase provides methylmalonyl-CoA precursors for monensin biosynthesis by *Streptomyces cinnamomensis* in an oil-based extended fermentation. *Microbiology* 150:3463–3472
- Lounes A, Lebrihi A, Benslimane C et al (1995) Regulation of valine catabolism by ammonium in *Streptomyces ambofaciens*, producer of spiramycin. *Can J microbial* 31:304–311
- MacKenzie CR, Bilous D, Schneider H, Johnson KG (1987) Induction of cellulolytic and xylanolytic enzyme systems in *Streptomyces* spp. *Appl Environ Microbiol* 53:2835–2839
- Madduri K, Stuttard C, Vining LC (1989) Lysine catabolism in *Streptomyces* spp is primarily through cadaverine:  $\beta$ -lactam producers also make  $\alpha$ -amino adipate. *J Bacteriol* 171:299–302
- Manteca A, Sanchez J (2009) *Streptomyces* development in colonies and soils. *Appl Environ Microbiol* 75:2920–2924
- Martín JF, Demain AL (1980) Control of antibiotic synthesis. *Microbiol Rev* 44:230–251
- Martin MC, Schneider D, Bruton CJ et al (1977) A *glgC* gene essential only for the first two spatially distinct phases of glycogen synthesis in *Streptomyces coelicolor* A3(2). *J Bacteriol* 179:7784–7789
- McBride MJ, Ensign JC (1987) Metabolism of endogenous trehalose by *Streptomyces griseus* spores and by spores or cells of other actinomycetes. *J Bacteriol* 169:5002–5007
- Mendelovitz S, Aharonowitz Y (1982) Regulation of cephamycin C synthesis, aspartokinase, dihydrodipicolinic acid synthase and homoserine dehydrogenase by aspartic acid family amino acids in *Streptomyces clavuligerus*. *Antimicrob Agents Chemother* 21:74–84

- Mendez C, Brana AF, Manzanal MB, Hardisson C (1985) Role of substrate mycelium in colony development in *Streptomyces*. *Can J Microbiol* 31:446–450
- Merrick MJ, Edwards RA (1995) Nitrogen control in bacteria. *Microbiol Rev* 59:604–622
- Moore SA, Ronimus RS, Roberson RS, Morgan HW (2002) The structure of a pyrophosphate-dependent phosphofructokinase from the Lyme disease spirochete *Borrelia burgdorferi*. *Structure (Camb)* 10:659–671
- Mostafa SA (1979) production of L-asparaginase by *Streptomyces karnatakensis* and *Streptomyces venezuelae*. *Zbl Bakt II Abt* 134:429–436
- Murphy MF, Katz E (1980) regulatory control of 3-deoxy-D-arabino-heptulosonic acid 7-phosphate synthetase in *Streptomyces antibioticus*. *Can J Microbiol* 26:874–880
- Nagawasa T, Kanzaki H, Yamada H (1984) Cystathionine  $\gamma$ -lyase of *Streptomyces phaeochromogenes*: the occurrence of cystathionine  $\gamma$ -lyase in filamentous bacteria and its purification and characterization. *J Biol Chem* 252:5267–5273
- Nguyen KT, Frabcou F, Virolle MJ, Guerieu M (1997) Amylase and chitinase genes in *Streptomyces lividans* are regulated by reg1, a pleiotropic regulatory gene. *J Bacteriol* 179:6383–6390
- Nguyen KT, Nguyen LT, Behal V (1995) The induction of valine dehydrogenase activity from *Streptomyces* by L-valine is not repressed by ammonium. *Biotechnol Lett* 17:31–34
- Nodwell JR, McGovern K, Losick R (1996) An oligopeptide permease responsible for the import of an extracellular signal governing aerial mycelium formation in *Streptomyces coelicolor*. *Mol Microbiol* 22:881–893
- Novak J, Kopecky J, Vanek Z (1997) Nitrogen source regulates expression of alanine dehydrogenase isoenzymes in *Streptomyces avermitilis* in a chemically defined medium. *Can J Microbiol* 43:189–193
- O'Hagan D, Rogers SV, Duffin GR, Reynolds KA (1995) The biosynthesis of monensin-A: thymine,  $\beta$ -aminoisobutyrate and methacrylate metabolism in *Streptomyces cinnamomensis*. *J Antibiot* 48:1280–1287
- Ohe T, Watanabe Y (1977) Effect of glucose and ammonium on the formation of xanthine dehydrogenase of *Streptomyces* sp. (Studies on the control of purine base metabolism in *Streptomyces*. Part II). *Agric Biol Chem* 41:1161–1170
- Olano C, Lombo F, Mendez C, Salas JA (2008) Improving production of bioactive secondary metabolites in actinomycetes by metabolic engineering. *Metab Eng* 10:281–292
- Paradkar AS, Stuttard C, vining LC (1993) Location of the genes for anthranilate synthase in *Streptomyces venezuelae* ISP5230: genetic mapping after integration of the cloned genes. *J Gen Microbiol* 139:687–694
- Piette A, Derouaux A, Gerkens P et al (2005) From dormant to germinating spores of *Streptomyces coelicolor* A3(2): new perspectives from the *crp* null mutant. *J Proteome Res* 4:1699–1708
- Pokorny M, Lj V, Turk V et al (1979) *Streptomyces rimosus* extracellular proteases. 1: Characterization and evaluation of various crude preparations. *Eur J Appl Microbiol* 8:81–90
- Potrykus K, Cashel M (2008) ppGpp: still magical? *Rev Microbiol* 62:35–51
- Pullan T, Chandra G, Bibb MJ, Merrick M (2011) Genome-wide analysis of the role of GlnR in *Streptomyces venezuelae* provides new insights into global nitrogen regulation in actinomycetes. *BMC Genomics* 12:175. doi:10.1186/1471-2164-12-175
- Rao NN, Torriani A (1990) Molecular aspects of phosphate transport in *Escherichia coli*. *Mol Microbiol* 4:1083–1090
- Rascher A, Hu Z, Viswanathan N et al (2003) Cloning and characterization of a gene cluster for geldanamycin production in *Streptomyces hygroscopicus* NRRL 3602. *FEMS Microbiol Lett* 218:223–230
- Reuther J, Wohlleben W (2007) Nitrogen metabolism in *Streptomyces coelicolor*: transcriptional and post-translational regulation. *J Mol Microbiol Biotechnol* 12:139–146
- Reynolds KA, O'Hagan D, Gani D, Robinson JA (1988) Butyrate metabolism in streptomycetes. Characterization of an intramolecular vicinal interchange rearrangement linking isobutyrate and butyrate in *Streptomyces cinnamomensis*. *J Chem Soc Perkin Trans* 1:3195–3207

- Rigali S, Titgemeyer F, Barends S, Mulder S, Thomae AW, Hopwood DA, van Wezel GP (2008) feast or famine: the global regulator DasR links nutrient stress to antibiotic production by *Streptomyces*. *EMBO Rep* 9:670–675
- Ring K, Foit B, Ehle H (1977) Stimulation of active uptake of 2-aminobutyric acid in *Streptomyces hydrogenans* by exogenous dibutyryl cyclic AMP. *FEMS Microbiol Lett* 2:27–30
- Rius N, Maeda K, Demain AL (1996) Induction of L-lysine  $\epsilon$ -aminotransferase by L-lysine in *Streptomyces clavuligerus*, producer of cephalosporins. *FEMS Microbiol Lett* 144:207–211
- Robbins PW, Overbye K, Albright C et al (1992) Cloning and high-level expression of chitinase-encoding gene of *Streptomyces plicatus*. *Gene* 111:69–76
- Rodríguez-García A, Barreiro C, Santos-Beneit F, Sola-Landa A, Martín JF (2007) Genome-wide transcriptomic and proteomic analysis of the primary response to phosphate limitation in *Streptomyces coelicolor* M145 and in a  $\Delta$ phoP mutant. *Proteomics* 7:2410–2429
- Rodríguez-García A., Sola-Landa A, Apel K., Santos-Beneit and Martín J.F. (2009) Phosphate control over nitrogen metabolism in *Streptomyces coelicolor*: direct and indirect negative control of *glnR*, *glnA*, *glnII* and *amtB* expression by the response regulator PhoP. *Nucl. Acids Res* 37: 3230–3242
- Rosenberg H, Gerdes RG, Chegwidan K (1977) Two systems for the uptake of phosphate in *Escherichia coli*. *J Bacteriol* 131:505–511
- Rosenberg H, Gerdes RG, Harold FM (1979) Energy coupling to the transport of inorganic phosphate in *Escherichia coli* K12. *Biochem J* 178:133–137
- Ryu YG, Butler MJ, Chater KF, Lee KJ (2006) Engineering of primary carbohydrate metabolism for increased production of actinorhodin in *Streptomyces coelicolor*. *Appl Environ Microbiol* 72:7132–7139
- Saier MH Jr, Reizer J (1994) The bacterial phosphotransferase system: new frontiers 30 years later. *Mol Microbiol* 13:755–764
- Sanchez S, Demain AL (2002) Metabolic regulation of fermentation processes. *Enz Microbial Technol* 31:895–906
- Santos-Beneit F, Rodríguez-García A, Franco-Domínguez E, Martín JF (2008) Phosphate-dependent regulation of the low- and high-affinity transport systems in the model actinomycete *Streptomyces coelicolor*. *Microbiology* 154:2356–2370
- Sawada Y, Nakashima S, Taniyama H (1977) Biosynthesis of streptothricin antibiotics. VI: mechanisms of  $\beta$ -lysine and its peptide formation. *Chem Pharm Bull* 25:3210–3217
- Schloesser A, Kampers T, Schrempf H (1997) The *Streptomyces* ATP binding component MsiK assists in cellobiose and maltose transport. *J Bacteriol* 179:2092–2095
- Seno ET, Chater KF (1983) Glycerol catabolic enzymes and their regulation in wild-type and mutant strains of *Streptomyces coelicolor* A3(2). *J Gen Microbiol* 129:1403–1413
- Shapiro S, Vining LC (1984) Suppression of nitrate utilization by ammonium and its relationship to chloramphenicol production in *Streptomyces venezuelae*. *Can J Microbiol* 30:798–804
- Shin H-S, Lee KJ (1986) Regulation of extracellular alkaline protease biosynthesis in a strain of *Streptomyces* sp. Kor. *J Microbiol* 24:32–37
- Smanski MJ, Peterson RM, Rajska SR, Shen B (2009) Engineered *Streptomyces platensis* strains that overproduce antibiotics platensimycin and platencin. *Antimicrob Agents Chemother* 53:1299–1304
- Smith DDS, Wood NJ, Hodgson DA (1995) Interaction between primary and secondary metabolism in *Streptomyces coelicolor* A3(2): role of pyrroline-5-carboxylate dehydrogenase. *Microbiology* 141:1739–1744
- Sola-Landa A, Moura RS, Martín JF (2003) The two-component PhoR-PhoP system controls both primary metabolism and secondary metabolite biosynthesis in *Streptomyces lividans*. *Proc Natl Acad Sci U S A* 100:6133–6138
- Sola-Landa A, Rodríguez-García A, Apel AK, Martín JF (2008) Target genes and structure of the direct repeats in the DNA-binding sequences of the response regulator PhoP in *Streptomyces coelicolor*. *Nucleic Acids Res* 36:1358–1368
- Sola-Landa A, Rodríguez-García A, Franco-Domínguez E, Martín JF (2005) Binding of PhoP to promoters of phosphate-regulated genes in *Streptomyces coelicolor*: identification of PHO boxes. *Mol Microbiol* 56:1373–1385

- Takano E (2006)  $\gamma$ -butyrolactones: *Streptomyces* signaling molecules regulating antibiotic production and differentiation. *Curr Op Microbiol* 9:287–294
- Tiffert Y, Franz-Wachtel M, Fladerer C et al (2011) Proteomic analysis of the GlnR-mediated response to nitrogen limitation in *Streptomyces coelicolor* M145. *Appl Microbiol Biotechnol* 89:1149–1159
- Tiffert Y, Supra P, Wurm R, Wohlleben W, Wagner R, Reuther J (2008) The *Streptomyces coelicolor* GlnR regulon: identification of new GlnR targets and evidence for a central role of GlnR in nitrogen metabolism in actinomycetes. *Mol Biol* 67:861–880
- Titgemeyer F, Reizer J, Reizer A, Saier MH Jr (1994) Evolutionary relationships between sugar kinases and transcriptional repressors in bacteria. *Microbiology* 140:2349–2354
- Tsuyuki H, Kajiwara K, Fujita A et al (1991) Purification and characterization of *Streptomyces griseus* metalloendopeptidases I and II. *J Biochem* 110:339–344
- Tyler B (1978) Regulation of the assimilation of nitrogen compounds. *Annu Rev Biochem* 47:1127–1162
- Udaka S (1966) Pathway specific pattern of control of arginine biosynthesis in bacteria. *J Bacteriol* 91:617–621
- Uwajima T, Yoshikawa N, Terada O (1973) Production of aminopeptidase and carboxypeptidase by *Streptomyces peptidofaciens*. *Agric Biol Chem* 37:1517–1523
- Van Wezel G, McDowall KJ (2011) The regulation of the secondary metabolism of *Streptomyces*: new links and experimental advances. *Nat Prod Rep* 28:1311–1333
- Vancura A, Rezanka T, Marsalek J et al (1987) Effect of ammonium on the composition of fatty acids in *Streptomyces fradiae*, producer of tylosin. *FEMS Microbiol Lett* 48:357–260
- Vancura A, Rezanka T, Marsalek J et al (1988) Metabolism of threonine and fatty acids and tylosin biosynthesis in *Streptomyces fradiae*. *FEMS Microbiol Lett* 49:411–415
- Virolle MJ, Long CM, Chang S, Bibb MJ (1988) Cloning, characterization and regulation of an  $\alpha$ -amylase gene from *Streptomyces venezuelae*. *Gene* 74:321–334
- Vorisek J, Powell AJ, Vanek Z (1969) regulation of biosynthesis of secondary metabolites. IV: Purification and properties of phosphoenolpyruvate carboxylase in *Streptomyces aureofaciens*. *Folia Microbiol* 14:398–405
- Vosbeck KD, Greenberg BD, Ochoa MS et al (1978) Proteolytic enzymes of the K-1 strain of *Streptomyces griseus* obtained from a commercial preparation (pronase). *J Biol Chem* 253:257–260
- Walker RD, Duerre JA (1975) S-adenosylhomocysteine metabolism in various species. *Can J Biochem* 53:312–319
- Walker JD, Hnilica VS (1964) Developmental changes in arginine: X aminotransferase activity in streptomycin-producing strains of *Streptomyces*. *Biochim Biophys Acta* 89:473–482
- van Wezel G, Konig M, Mahr K, Nothaft H, Thomae AW, Bibb M, Titgemeyer F (2007) A new piece of an old jigsaw: glucose kinase is activated posttranslationally in a glucose transport-dependent manner in *Streptomyces coelicolor* A3(2). *J Mol Microbiol Biotechnol* 12:67–74
- van Wezel GP, Mahr K, Konig M, Traag BA, Pimentel-Schmitt EF, Willimek A, Titgemeyer F (2005) GlcP constitutes the major glucose uptake system of *Streptomyces coelicolor* A3(2). *Mol Microbiol* 55:624–636
- van Wezel GP, White J, Young P, Postma PW, Bibb MJ (1997) Substrate induction and glucose repression of maltose utilization by *Streptomyces coelicolor* A3(2) is controlled by *malR*, a member of the *lacI-galR* family of regulatory genes. *Mol Microbiol* 23:537–549
- White PJ, Young J, Hunter IS, Nimmo HG, Coggins JR (1990) The purification and characterization of 3-dehydroquinase from *Streptomyces coelicolor*. *Biochemical Journal* 265:735–738
- Williams ST (1985) Oligotrophy in soil: fact or fiction. In: Fletcher M, Floodgate GD (eds) *Bacteria in their natural environments*. Academic Press, London, pp 81–110
- Wilson DJ, Xue YQ, Reynolds KA, Sherman DH (2001) Characterization and analysis of the PikD regulatory factor in the pikromycin biosynthetic pathway of *Streptomyces venezuelae*. *J Bacteriol* 183:3468–3475
- Wohlleben W, Mast Y, Reuthler J (2011) Regulation of nitrogen assimilation in streptomycetes and other actinobacteria. In: Dyson P (ed) *Streptomyces: molecular biology and biotechnology*. Caister Academic Press, Norfolk, UK, pp 125–136

- 
- Wong HC, Ting Y, Lin HC et al (1991) Genetic organization and regulation of the xylose degradation genes in *Streptomyces rubiginosus*. *J Bacteriol* 173:6849–6858
- Wray LV Jr, Fisher SH (1998) Cloning and nucleotide sequence of the *Streptomyces coelicolor* gene encoding glutamine synthetase. *Gene* 71:247–256

---

# Regulation of Secondary Metabolites of *Actinobacteria*

# 8

Wolfgang Wohlleben, Agnieszka Bera, Yvonne Mast, and Evi Stegmann

---

## 8.1 Introduction

Regulation of secondary metabolite biosynthesis is a complex process, which depends on various factors and is mediated by global, as well as pathway-specific, regulators. As general factors, diverse physiological signals/conditions have been described to generally influence antibiotic biosynthesis, such as exposure to nutrient starvation/limitation (nutrient stress), reactive oxygen and nitrogen species (oxidative/nitrosative stress), membrane damage (envelope stress), elevated temperature (heat stress), and ribosome disruption (ribosomal stress) (Poole 2012; Bibb 2005).

---

## 8.2 Growth Rate and Nutritional Control During Secondary Metabolite Production

Antibiotic production in streptomycetes occurs generally in a growth-phase-dependent manner (Demain 1995). In liquid culture, antibiotic production (excluding lantibiotics) is limited to stationary phase and coincides with reduction in growth rate or even growth cessation that is often a consequence of nutrient(s) depletion

---

W. Wohlleben (✉) • Y. Mast • E. Stegmann  
Department of Microbiology/Biotechnology, Interfaculty Institute of Microbiology and Infection Medicine, University of Tübingen,  
Auf der Morgenstelle 28, 72076 Tübingen, Germany

German Centre for Infection Research (DZIF), Tübingen, Germany  
e-mail: [wolfgang.wohlleben@biotech.uni-tuebingen.de](mailto:wolfgang.wohlleben@biotech.uni-tuebingen.de)

A. Bera  
Department of Microbiology/Biotechnology, Interfaculty Institute of Microbiology and Infection Medicine, University of Tübingen,  
Auf der Morgenstelle 28, 72076 Tübingen, Germany



(Demain et al. 1983; Bibb 2005). In solid culture, antibiotic production is temporally correlated with morphological differentiation triggered through nutrient starvation. Numerous studies have shown that availability of carbon, phosphate, and nitrogen source can influence antibiotic production. Stimulatory or inhibitory effect of the particular nutrient on the antibiotic production is determined by the developmental program of the individual strain, type of the synthesized antibiotic, as well as variety of environmental stimuli and cultivation conditions employed (van Wezel and McDowall 2011).

### 8.2.1 Influence of Phosphate on Antibiotic Production

Although phosphate is indispensable for bacterial growth, phosphate limitation usually results in the stimulation of the antibiotic production in *Actinobacteria* (Martin 2004) (Table 8.1). The cellular response to phosphate limitation is controlled by the two-component system PhoR-PhoP, which is widely distributed across prokaryotes (Santos-Beneit 2015). PhoR (membrane sensor kinase) senses and transmits the phosphate scarcity signal to PhoP (OmpR/PhoP family response regulator), which elicits the appropriate response on transcriptional level. PhoP is able to recognize and bind to PHO boxes (GTTCACC in *S. coelicolor* (Sola-Landa et al. 2008)) located in the upstream regions of PhoP target genes. The PhoP regulon includes genes necessary for phosphate scavenging, transport, and storage (Martin 2004), such as *phoA*, *phoD* (encoding alkaline phosphatases) (Apel et al. 2007), *pstSCAB* (encoding phosphate transporter system), *pitH2* (encoding phosphate uptake system) (Sola-Landa et al. 2005), *ppk* (encoding polyphosphate kinase) (Chouayekh and Virolle 2002), *glpQ1* and *glpQ2* (encoding glycerophosphodiester phosphodiesterases (GDPD)) (Santos-Beneit et al. 2009a), and *SCO7697* (encoding phytase) (Boukhris et al. 2016; Sola-Landa et al. 2008). Apart from activation of pathways for phosphate scavenging, PhoP exerts its direct or indirect regulatory function on the cell wall/extracellular polymer biosynthesis, extracellular sugar phosphate assimilation (Tenconi et al. 2012), nitrogen assimilation, oxidative phosphorylation, nucleotide biosynthesis, and glycogen catabolism as well as on secondary metabolite production and morphological differentiation (Allenby et al. 2012). Direct implication of the PhoP regulator in the transcriptional control of secondary metabolite clusters was reported only for four bacteria: *S. lividans* (Sola-Landa et al. 2003), *S. coelicolor* (Santos-Beneit et al. 2009b; Fernández-Martínez et al. 2012; Thomas et al. 2012), *S. natalensis* (Mendes et al. 2007), and *S. avermitilis* (Yang et al. 2015). In *S. lividans*, deletion of *phoP* and *phoRP* resulted in an enhanced actinorhodin and undecylprodigiosin production on R5 medium (Sola-Landa et al. 2003). Deletion of *phoP* in *S. coelicolor* increased actinorhodin and undecylprodigiosin production on R5 medium but decreased antibiotic production on defined medium supplemented with starch (Santos-Beneit et al. 2009b; Fernández-Martínez et al. 2012; Thomas et al. 2012), indicating that the PhoP effect is more complex and seems to be media dependent. Production of pimaricin increased up to 80% in complex yeast extract-malt extract (YEME) or NBG media after deletion of *phoP* or

**Table 8.1** Examples of phosphate-controlled antibiotic production in *Actinobacteria*

Secondary metabolite	Producer	Optimal phosphate concentration for antibiotic production (mM)	Regulated target	References
Actinomycin	<i>S. antibioticus</i>	<17	NR (not reported)	Katz et al. (1958)
Actinorhodin	<i>S. lividans</i>	<0.37	Pathway-associated regulator AfsR2 Polyphosphate kinase Ppk	Sola-Landa et al. (2003), Chouayekh and Virolle (2002), Gunnarsson et al. (2003), and Shao et al. (2015b)
Actinorhodin Undecylprodigiosin	<i>S. coelicolor</i>	<1–2.5	Sigma-like protein AfsS RNA polymerase RpoZ RelA/SpoT homologue RshA	Santos-Beneit et al. (2011b), Santos-Beneit et al. (2009b), Doull and Vining (1990), Santos-Beneit et al. (2011a), and Ryu et al. (2007)
Antifungals	<i>S. aburaviensis</i> var. <i>ablastmyceticus</i>	0.4	NR	Raytapadar and Paul (2001)
Anthracycline	<i>S. peuceitius</i>	<1	NR	Dekleva et al. (1985)
Armentomycin	<i>S. sarmentosus</i>	<3	NR	He et al. (1995)
Avermectin	<i>S. avermitilis</i>	<0.05	Cluster-specific regulator AveR	Yang et al. (2015)
Avilamycin	<i>S. viridochromogenes</i> AS4.126	<10	Phosphofructokinase PfkA	Zhu et al. (2007)
Balhimycin	<i>Amycolatopsis balhimycina</i>	<0.6	NR	Maiti et al. (2010) and Gallo et al. (2010)
Candidin	<i>S. griseus</i>	<1	<i>p</i> -Aminobenzoic acid (PABA) synthase PabS	Asturias et al. (1990), Liras et al. (1977), and Martin (2004)
Cephalosporin	<i>S. clavuligerus</i> NRRL 3585	<20–25	Deacetoxycephalosporin C synthase CefE	Zhang and Demain (1991) and Aharonowitz and Demain (1977)

(continued)

Table 8.1 (continued)

Secondary metabolite	Producer	Optimal phosphate concentration for antibiotic production (mM)	Regulated target	References
Cephameycin	<i>S. cattleya</i>	<1	NR	Lilley et al. (1981) and Romero et al. (1984)
	<i>S. clavuligerus</i>	<20–25	NR	
Clavulanic acid	<i>S. clavuligerus</i>	<0.7	NR	Kirk et al. (2000) and Romero et al. (1984)
	<i>S. griseus</i>	<0.5	NR	
Cycloheximide	<i>S. griseus</i>	<0.5	NR	Abouzeid (1972)
Dalbavancin (A40926)	<i>Nomomuraea</i> sp.	<2	Cluster-specific regulator Dbv4	Alduina et al. (2007) and Gunnarsson et al. (2003)
Echinomycin (quinomycin A)	<i>S. echinatus</i>	50	NR	Formica and Waring (1983)
Erythromycin	<i>Saccharopolyspora erythraea</i>	<1	NR	Reeve and Baumberg (1998)
Frülimicin	<i>Actinoplanes früliensis</i>	<0.5	NR	Steinkämper et al. (2015)
Gentamicin	<i>Micromonospora purpurea</i>	<1.4	NR	Obregon et al. (1994)
Jadomycin	<i>S. venezuelae</i>	0.05–0.1	NR	Jakeman et al. (2006)
Kanamycin	<i>S. kanamyceticus</i>	5.7	NR	Basak and Majumdar (1975)
Levorin	<i>S. levoris</i>	<4	NR	Belousova et al. (1970)
Lincomycin	<i>S. lincolhensis</i>	<2.8	NR	Young et al. (1985)

Monamycin	<i>S. jamaicensis</i>	<0.14	NR	Hall and Hassall (1970)
NAI-107 lantibiotic	<i>Microbispora</i> sp. ATCC-PTA-5024	0.5–30	NR	Giardina et al. (2014)
Nanaomycin	<i>S. rosa</i> subsp. <i>notoensis</i>	<0.07	NR	Masuma et al. (1986)
Natamycin	<i>S. natalensis</i>	<6.84	NR	Farid et al. (2000)
Neomycin	<i>S. fradiae</i>	5.7	Alkaline phosphatase	Majumdar and Majumdar (1965, 1971)
Nikkomycin	<i>S. tendae</i>	<1	NR	Hegetreskatis et al. (1992)
Nourseothricin	<i>S. noursei</i>	0–0.1	NR	Müller et al. (1984)
Novobiocin	<i>S. niveus</i>	9–40	NR	Hoeksema and Smith (1961)
Nystatin	<i>S. noursei</i>	<2.2	NR	Tereshin (1976)
Oleandomycin	<i>S. antibioticus</i>	<1	NR	Torbochkina et al. (1965)
Oxytetracycline	<i>S. rimosus</i>	<1	Anhydrotetracycline oxygenase OtcC Tetracycline polyketide synthase OtcX (unknown function) and OtcY	McDowall et al. (1999)
Picromycin	<i>S. venezuelae</i>	30	NR	Yi et al. (2015)
Pimaricin (natamycin)	<i>S. natalensis</i>	<0.3	Formation of the polyketide aglycone PimS1, PimS4 Aminotransferase PimC P450 monooxygenase PimG	Farid et al. (2000) and Mendes et al. (2007)
Polyketide antibiotic SBR-22	<i>Streptomyces</i> sp. BT-408	7	NR	Cheng et al. (1995)
Pristinamycin	<i>S. pristinaespiralis</i>	<0.2	NR	Voelker and Altaba (2001)

(continued)

Table 8.1 (continued)

Secondary metabolite	Producer	Optimal phosphate concentration for antibiotic production (mM)	Regulated target	References
Pyrarazoloisoquinolinone (APHE-1 to APHE-4)	<i>S. griseocarneus</i> NCIMB 40447	40–100	NR	Cruz et al. (1999)
Spiramycin	<i>S. ambofaciens</i>	<10	Valine dehydrogenase Vdh Alkaline phosphatase	Lounes et al. (1996b)
Streptomycin	<i>S. griseus</i>	<15	Guanidinodeoxy- <i>scyllo</i> -inositol phosphatase	Miller and Walker (1970) and Walker and Walker (1971)
Tacrolimus	<i>S. tsukubaensis</i>	<2.5	NR	Martinez-Castro et al. (2013)
Tetracycline	<i>S. aureofaciens</i>	<0.1	Anhydrotetracycline oxygenase	Behal et al. (1982)
Thienamycin	<i>S. cattleya</i>	<0.3	NR	Lilley et al. (1981)
Tylosin	<i>Streptomyces</i> sp. T 59-235	<5	dTDP-D-glucose-4,6-dehydratase, dTDP-mycarose-forming enzyme system. SAM: macrocin	Madry and Pape (1982) and Vu-Trong et al. (1981)
	<i>S. fradiae</i> NRRL 2702	<3.4	O-methyltransferase, methylmalonyl-coenzyme A carboxyltransferase, propionyl-coenzyme A carboxylase	
Vancomycin	<i>Amycolatopsis orientalis</i>	<0.1	NR	McIntyre et al. (1996)
Viomycin	<i>S. vinaceus</i>	NR	Alkaline phosphatase	Pass and Raczynska-Bojanowska (1968)

*phoR-phoP* in *S. natalensis* (Mendes et al. 2007). Transcriptional analysis revealed that four genes from the pimarin cluster (*pimS1*, *pimS4*, *pimC*, and *pimG*) showed increased expression in the *phoP* mutant (Mendes et al. 2007). PhoP directly affects avermectin biosynthesis in *S. avermitilis* by repressing expression of the cluster-situated regulator AveR (Yang et al. 2015).

In several studies, a phosphate-dependent gene expression and activity of enzymes involved in secondary metabolite production were described, although no direct regulatory role of PhoP was detected. For instance, phosphate excess (7.5 mM) dramatically reduced expression of *pabS*, which encodes p-aminobenzoic acid (PABA) synthase involved in candicidin precursor biosynthesis in *S. griseus* (Asturias et al. 1990). Similarly high phosphate concentration abolished expression of the dalbavancin cluster-situated regulator Dbv4 in *Nonomuraea* sp. (Alduina et al. 2007). Interestingly, no PhoP-binding boxes were found in the promoter region of *dbv4*, as well as in the entire dalbavancin cluster, which suggests the involvement of an additional regulator or an indirect regulation by phosphate availability. Expression of three genes—*otcC* (encoding anhydrotetracycline oxygenase), *otcY* (encoding tetracycline polyketide synthase), and *otcX* (unknown function)—from the tetracycline cluster was observed only under phosphate-limiting conditions (McDowall et al. 1999).

In addition to PhoP-governed transcriptional regulation of several genes from different antibiotic clusters, activity of several enzymes was reported to be influenced by the phosphate level. Activity of three enzymes involved in tylosin biosynthesis (dTDP-D-glucose-4,6-dehydratase, dTDP-mycarose-forming enzyme system, and SAM: macrocin O-methyltransferase) in *Streptomyces T59-235* was significantly reduced under phosphate excess (30 mM) resulting in the inhibition of tylosin production (Madry and Pape 1982). High phosphate concentrations inhibited the activities of methylmalonyl-coenzyme A carboxyltransferase and propionyl-coenzyme A carboxylase during the production of tylosin in *S. fradiae* (Vu-Trong et al. 1981). The catalytic activity of deacetoxycephalosporin C synthase from *S. clavuligerus* was inhibited by high levels of phosphate in cephalosporin production medium (Zhang and Demain 1991). The phosphatases which catalyze the final biosynthetic step in some pathways cleaving biologically inactive phosphorylated intermediates are often regulated via feedback inhibition or repression by phosphate (Martin and Demain 1980). For instance, accumulation of the inactive phosphorylated derivative of streptomycin was a consequence of the repression of the guanidinodeoxy-scylo-inositol phosphate phosphatase in *S. griseus* (Miller and Walker 1970; Walker and Walker 1971). Production of viomycin (Pass and Raczynska-Bojanowska 1968), spiramycin (Lounes et al. 1996b), and neomycin (Majumdar and Majumdar 1971) was inhibited by phosphate excess, which directly repressed expression or inhibited the activity of alkaline phosphatases.

Besides phosphate regulatory effects on the gene expression and enzyme activity, also an indirect phosphate implication in antibiotic production was reported. Phosphate limitation triggers stringent response leading to an increased production of the alarmone (p)ppGpp. Under phosphate limitation, (p)ppGpp levels are

controlled by the *rshA* gene product, a bifunctional enzyme involved in both synthesizing and degrading (p)ppGpp (Ryu et al. 2007). The stringent factor (p)ppGpp was reported to stimulate secondary metabolism production and morphological differentiation in streptomycetes (Ochi 1986; Strauch et al. 1991). Deletion of *rshA* in *S. coelicolor* influenced mycelial morphology, accelerated sporulation, and completely abolished actinorhodin production (Ryu et al. 2007).

Whereas phosphate limitation in most cases induces antibiotic production, also opposite effects are known. High phosphate concentrations (10–50 mM) were reported to trigger antibiotic production, as shown among others for methylenomycin production in *S. coelicolor* A3(2), novobiocin production in *S. niveus* (Hoeksema and Smith 1961), picromycin production in *S. venezuelae*, and echinomycin (quinomycin A) production in *S. echinatus* (Formica and Waring 1983). Recently, a positive effect of high phosphate concentrations on the biosynthesis of the lantibiotic NAI-107 in *Microbispora* sp. ATCC-PTA-5024 was reported. In this study, phosphate positively influenced both growth and NAI-107 production up to a concentration of 5 mM. Higher phosphate concentrations (30 mM) did not prevent NAI-107 production. However, in the presence of phosphate excess, no further enhancement of NAI-107 production was observed (Giardina et al. 2014). Although the control of antibiotic production by phosphate has been profoundly studied, the molecular mechanism of this control in most investigated strains remains unclear.

Changes in the level of the inorganic phosphate influence both primary and secondary metabolism, forcing continuous adaptation of the cell to new conditions (Martin 2004; Martin et al. 2011). This “metabolic homeostasis,” in response to phosphate imbalance, is assured by the interaction or competition between PhoP and other global regulators related to nutrition such as GlnR (Rodriguez-Garcia et al. 2009), DasR (Rigali et al. 2008; van Wezel and McDowall 2011), and ArgR (Perez-Redondo et al. 2012). Additionally, a cross talk between PhoP and other pleiotropic regulators of secondary metabolite production and morphological differentiation, such as AtrA (Allenby et al. 2012) and AfsR (Santos-Beneit et al. 2009a, b, 2011a), helps to adjust the nitrogen, carbon, and secondary metabolism in *S. coelicolor* to phosphate availability (Santos-Beneit 2015; Martin et al. 2011).

### 8.2.2 Influence of Carbon on the Secondary Metabolite Production

Formation of secondary metabolites is not only influenced by phosphate availability, but it is also subjected to regulation by the nature and concentration of the carbon source. A rapidly assimilated carbon source, such as glucose, favors high growth rate and usually represses secondary metabolite production through carbon

catabolite repression (CCR) (Sanchez et al. 2010). The CCR mechanism ensures the selective utilization of carbon sources when more than one carbon source is present in the environment (Romero-Rodríguez et al. 2016; Sanchez et al. 2010). Depletion of glucose from the medium often derepresses CCR-affected genes and induces a “metabolic switch” necessary for the assimilation of an alternative carbon source. Depletion of glucose lowers the growth rate and leads usually to the induction of secondary metabolite production.

### 8.2.2.1 Carbon Catabolic Repression by Glucose in Streptomyces

Though the phosphoenolpyruvate-dependent phosphotransferase system (PTS) plays a dominant role in CCR in low-GC Gram-positive bacteria and Gram-negative enteric bacteria, a direct role of the PTS in CCR by glucose in streptomyces has not been demonstrated (Butler et al. 1999; Nothaft et al. 2003; Parche et al. 1999; Rigali et al. 2006). In *S. coelicolor*, CCR by glucose involves the regulatory and catalytic activity of the glucose kinase (Glk) (Kwakman and Postma 1994; Görke and Stülke 2008). Glk interacts with a glucose permease (GlcP) and converts glucose into glucose 6-phosphate (van Wezel et al. 2007). Unknown intracellular sugar metabolites activate Glk or an unknown factor that is required for posttranslational modification of this enzyme changing its catabolic activity into the regulatory one, resulting in CCR (van Wezel et al. 2007). In a *glk* deletion mutant, neither glucose nor any other readily usable carbon source exerts CCR (Görke and Stülke 2008). As Glk is not involved in the metabolism of alternative carbon sources, which are different from glucose, it was concluded that catabolic or regulatory activity of Glk, rather than the flux through Glk, is important for CCR (Kwakman and Postma 1994; Görke and Stülke 2008). This conclusion was supported by the observation that a heterologous Glk from *Zymomonas mobilis* restored glucose utilization, but not CCR, in *S. coelicolor* (Angell et al. 1994). Glk interacts with several proteins, such as glucose permease (GlcP) (van Wezel et al. 2005), protein SCO2127 (necessary for full activity of Glk) (Forero et al. 2012), and SblA (involved in phospholipid catabolism) that seemingly determine the regulatory and catalytic activity of this bifunctional enzyme during CCR (van Wezel and McDowall 2011). Although the role of CCR and its effect on the secondary metabolite production has been extensively studied in *S. coelicolor*, the precise regulatory mechanism of Glk has to be elucidated (Romero-Rodríguez et al. 2016; van Wezel and McDowall 2011). Recently, a high-density microarray approach applied to *S. coelicolor* M145 under glucose repressed and non-repressed conditions revealed that glucose influenced the expression of 651 genes. However, comparison of the transcriptomic profile of *S. coelicolor* M145 with that of a  $\Delta glk$  mutant complemented with a heterologous *glk<sub>Zm</sub>* gene from *Zymomonas mobilis* (insensitive to CCR) revealed differential expression of 134 genes. From these 91 were also affected by glucose, while only 43 appeared to be under control of Glk (Romero-Rodríguez et al. 2016). Most of the genes, of which expression was



influenced by glucose or Glk, encoded proteins involved in primary metabolism including glycolysis, pentose phosphate pathway, gluconeogenesis, as well as transport and utilization of secondary carbon sources such as maltose, xylose, glycerol, and glutamate (Romero-Rodríguez et al. 2016). In this study, 40 transcriptional factors associated with CCR were reported, including GlnR (Tiffert et al. 2011), Rok7B7 (Swiatek et al. 2013; Park et al. 2009), GntR-like SCO3264 (Romero-Rodríguez et al. 2016), or ArgR (Perez-Redondo et al. 2012) interlinking directly or indirectly secondary metabolite production with CCR (Romero-Rodríguez et al. 2016). Therefore, understanding the functions of the glucose-targeted transcriptional regulators and clarification of their transcriptional network will be the major step forward in unraveling links between CCR and secondary metabolite production.

### 8.2.2.2 Influence of Glucose on Secondary Metabolite Production

CCR by glucose is strictly strain and secondary metabolite pathway dependent (Table 8.2). For instance, concentration of above 0.1% glucose prevents actinorhodin production in *S. lividans* by repressing the expression of AfsR2 (Kim et al. 2001); however, *S. coelicolor* is still capable to produce actinorhodin in the presence of 2.5% glucose. Actinorhodin production is completely abolished when *S. coelicolor* was cultivated on R5 medium supplemented with 3.6% of glucose (Forero et al. 2012). In *S. peucetius* var. *caesius*, anthracycline and doxorubicin production were negatively affected by glucose concentrations above 1.8% (Escalante et al. 1999). The production of retamycin in *S. olindensis* was subjected to CCR by even higher glucose concentrations of 2.5%, whereas lowering the glucose concentration to 1.0% restored retamycin production (Inoue et al. 2007). Furthermore, an elevated initial glucose concentration negatively influenced chloramphenicol productivity, but did not delay the initiation of antibiotic biosynthesis in *S. venezuelae* batch cultivations (Bhatnagar et al. 1988). Although the CCR is normally caused by glucose, other rapidly metabolizable carbon sources, such as glycerol, maltose, mannose, sucrose, xylose, and citrate, can also cause repression (Sanchez and Demain 2002) (Table 8.2). For example, *S. niveus* prefers citrate as a carbon source in the presence of glucose, and only after citrate is exhausted from the medium, novobiocin is produced at the expense of glucose (Kominek 1972). In *S. clavuligerus*, cephamycin C production is subjected to CCR by glycerol (Aharonowitz and Demain 1978). The phenomenon of an abolished or delayed secondary metabolite biosynthesis due to CCR by glucose is not restricted solely to streptomycetes. Glucose represses the formation of many aminoglycoside antibiotics produced by actinomycetes, such as streptomycin, kanamycin, istamycin, and neomycin, via repression of biosynthetic enzymes (Piepersberg and Distler 1997; Demain 1989; Sanchez and Demain 2002). High glucose concentrations have also been reported to repress the formation of erythromycin in *Saccharopolyspora erythraea* (Sanchez and Demain 2002) and vancomycin in *Amycolatopsis orientalis* (Ayar-Kayali and Tarhan 2006).

**Table 8.2** Examples of carbon source-controlled secondary metabolite production in *Actinobacteria*

Secondary metabolite	Producer	Optimal concentration of carbon source for antibiotic production	Regulated target	References
2-Methylheptyl isonicotinate	<i>Streptomyces</i> sp. 201	Mannitol 1.5 g/L	NR (not reported)	Thakur et al. (2009)
Actinomycin IV	<i>S. parvulus</i>	Galactose 10 g/L Glucose 1 g/L	Hydroxykynureninase Kynurenine formamidase II Tryptophan pyrrolase	Brown et al. (1980) and Gallo and Katz (1972)
Actinorhodin	<i>S. lividans</i>	Glycerol 2.5 g/L	Pathway-specific regulator AfsR2	Kim et al. (2001) and Im et al. (2009)
Actinorhodin	<i>S. coelicolor</i>	Sucrose 340 g/L	NR	Elilbol and Mavituna (1998)
Actinorhodin	<i>S. coelicolor</i>	Glucose 5 g/L	AfsR2-like transcriptional regulator Glucose kinase G1k SCO2127—regulatory protein	Lee et al. (2009), Lee and Kim (2008), van Wezel and McDowall (2011), and Forero et al. (2012)
AK-111-81	<i>S. hygrosopicus</i>	Lactose 25 g/L	NR	Gesheva et al. (2005)
Anthracycline	<i>S. peuceitius</i>	Mannose 20 g/L	NR	Dekleva et al. (1985)
Armentomycin	<i>S. sarmentosus</i>	Starch 30 g/L	NR	He et al. (1995)
Avermectin	<i>S. avermitilis</i> <i>S. avermitilis</i> 14-12a	Starch 150 g/L	NR	Ikedda et al. (1988), Xu and Cen (1999), and Chen et al. (2016)
Avilamycin	<i>S. viridochromogenes</i>	Glucose 20 g/L	NR	Zhu et al. (2007)
Capuramycin	<i>S. griseus</i> SANK 60196	Maltose 30 g/L	NR	Muramatsu et al. (2006)
Cephameycin C	<i>S. clavuligerus</i>	Glycerol 5 g/L, starch 5 g/L, maltose 5 g/L	Cephameycin C synthetase Expandase	Aharonowitz and Demain (1978)
Cephameycin C	<i>S. lactamdurans</i>	Glucose 5 g/L	Deacetoxycephalosporin C synthase	Cortes et al. (1984)

(continued)

Table 8.2 (continued)

Secondary metabolite	Producer	Optimal concentration of carbon source for antibiotic production	Regulated target	References
Chloramphenicol	<i>S. venezuelae</i>	Glucose, lactose	Arylamine synthetase	Bhatnagar et al. (1988)
Erythromycin	<i>S. erythraea</i>	Glucose 15 g/L Glycerol 15 g/L	<i>S</i> -adenosylmethionine erythromycin- <i>O</i> - methyltransferase Methylmalonyl-CoA-mutase	Bermudez et al. (2006)
Erythromycin	<i>S. erythraea</i>	Glucose 1 g/L	Type I polyketide synthase	Reeve and Baumberg (1998)
Fungichromin	<i>S. pedanus</i> PMS-702	Glucose 5 g/L	NR	Huang et al. (2007)
Heliomycin	<i>S. olivocinereus</i> 11-98	Arabinose + glycerol Sucrose + glycerol	NR	Deianova et al. (1988)
Jadomycin B	<i>S. venezuelae</i> ISP 5230	Glucose 3 g/L	NR	Jakeman et al. (2006)
Kanamycin	<i>S. kanamyceticus</i> M27	Dextrose 15 g/L	NR	Pandey et al. (2005)
Kanamycin	<i>S. kanamyceticus</i>	Galactose 20 g/L	<i>N</i> -acetylkanamycin amidohydrolase	Basak and Majumdar (1975), Demain (1989), and Satoh et al. (1975)
Lincomycin	<i>S. lincolnensis</i>	Glucose 30 g/L	NR	Young et al. (1985)
Methylenomycin	<i>S. coelicolor</i> A3(2)	Fructose 10 g/L	NR	Hobbs et al. (1992)
Natamycin	<i>S. natalensis</i>	Glucose 20 g/L	NR	Farid et al. (2000)
	<i>S. gilvosporeus</i>	Glucose 38 g/L	NR	Chen et al. (2008a)
Neomycin	<i>S. fradiae</i>	Arabinose 1 g/L	Alkaline phosphatase	Demain (1989) and Bandyopadhyay and Majumdar (1974)
Niromycin	<i>S. endus</i> N40	Maltose 6 g/L	NR	El-Shirbiny et al. (2007)
Novobiocin	<i>S. niveus</i>	Citrate 6 g/L Glucose 30 g/L	NR	Kominek (1972)
Oleandomycin	<i>S. antibioticus</i>	Fructose 10 g/L	NR	Vilches et al. (1990)
Oxytetracycline	<i>S. rimosus</i>	Starch 20 g/L	NR	Yang and Lee (2001)

Pikromycin	<i>S. venezuelae</i>	Glucose 20 g/L + sucrose 139 g/L	NR	Yi et al. (2015)
Polyketide antibiotic SBR-22	<i>Streptomyces</i> BT-408	Glucose 10–12 g/L	NR	Sujatha et al. (2005)
Pyrazoloisouinolone	<i>S. griseocameus</i> NCIMB 40447	Glucose 7.5 g/L	NR	Cruz et al. (1999)
Pyroindomycin	<i>S. rugosporus</i> LL-42D005	Glucose 5–7.5 g/L Mannitol 5–7.5 g/L	NR	Abbanat et al. (1999)
Rapamycin	<i>S. hygrosopicus</i> MITC 4003	Fructose 27 g/L Fructose 20 g/L + mannose 5 g/L	NR	Dutta et al. (2014) and Kojima et al. (1995)
Simocyclinone	<i>S. antibioticus</i> Tü6040	Glycerol 20–25 g/L	NR	Theobald et al. (2000) and Schimana et al. (2001)
Spiramycin	<i>S. ambofaciens</i>	Dextrin 25 g/L + glucose 15 g/L	NR	Ashy et al. (1982)
Spiramycin	<i>S. ambofaciens</i>	Glucose 20 g/L	NR	Lounes et al. (1996b)
Streptomycin	<i>S. griseus</i>	Glucose 10 g/L	Mannosidostreptomycinase	Demain and Inamine (1970)
Tetracycline	<i>S. aureofaciens</i>	Sucrose 40 g/L	Anhydrotetracycline oxygenase	Erban et al. (1983)
Tetraene polyene HA-2-9J	<i>S. arenae</i> var. <i>ukrainiana</i>	Starch 10 g/L	NR	Gupte and Naik (1998)
Tylosin	<i>S. fradiae</i> TM-224-4 <i>S. fradiae</i>	Glucose 35 g/L	Methylmalonyl-coenzyme A carboxyltransferase, propionyl-coenzyme A carboxylase	Choi et al. (2007), Vu-Trong et al. (1980)
Vancomycin	<i>Amycolatopsis</i> <i>orientalis</i>	Glucose 15 g/L	NR	Ayar-Kayali and Tarhan (2006)
Viridomycin	<i>S. griseus</i>	Fructose 20 g/L	NR	Kurobane et al. (1987)

### 8.3 Regulatory Aspects of Nitrogen Metabolism

To respond to the changes in nitrogen availability, *Actinobacteria* have developed a complex regulatory system for nitrogen assimilation, comprising transcriptional and posttranslational control. The cellular response to nitrogen limitation on the transcriptional level is controlled by the global nitrogen response regulator GlnR, of which the regulatory role was broadly explored for *S. coelicolor* (Amin et al. 2016; Fink et al. 2002; Tiffert et al. 2008, 2011; Wray et al. 1991; Wray and Fisher 1993), *S. venezuelae* (Pullan et al. 2011), *M. smegmatis* (Amon et al. 2008; Jenkins et al. 2013), *M. tuberculosis* (Malm et al. 2009), *A. mediterranei* (Yu et al. 2007), and *S. erythraea* (Yao et al. 2014). The GlnR regulon in *S. coelicolor* comprises genes, which are directly involved in nitrogen assimilation, including the *amtB-glnK-glnD* operon (ammonium transporter AmtB—PII signal protein GlnK—adenylyltransferase GlnD), *nasA* (nitrate reductase), *nirB* (nitrite reductase), *ureA* (urease), *glnA* (glutamine synthetase I), *glnII* (glutamine synthetase II), *gdhA* (NADP-specific glutamate dehydrogenase), *nnaR* (HemD-like transcriptional regulator), and seven additional genes encoding proteins of unknown function (Amin et al. 2012; Reuther and Wohlleben 2007; Tiffert et al. 2008; Wang and Zhao 2009). Proteomic analysis demonstrated a more comprehensive regulatory role of GlnR in connection with central carbon metabolite pathways in *S. coelicolor* M145 (Tiffert et al. 2011). Over 50 proteins associated with amino acid biosynthesis and carbon metabolism have been shown to be differentially expressed between the parental strain *S. coelicolor* M145 and a *glnR* mutant (Tiffert et al. 2011). GlnR-mediated control of carbohydrate transport (Liao et al. 2015) and regulation of ectoine biosynthesis (Shao et al. 2015a, b) extended the role of GlnR beyond the regulation of nitrogen assimilation. Direct implication of GlnR in the transcriptional regulation of secondary metabolite cluster has been described only for validamycin biosynthesis in *S. hygroscopicus var. jinggangensis* 5008 (Qu et al. 2015). Here, GlnR was shown to act as an activator and repressor by binding within the *valK-valA* intergenic region of the validamycin gene cluster (Qu et al. 2015).

Nitrate assimilation in *S. coelicolor* undergoes cooperative control by two regulators: GlnR and NnaR. This was shown by the deletion of *glnR* or *nnaR*, which each resulted in a growth defect on defined solid medium with nitrate (Amin et al. 2012; Tiffert et al. 2008). Expression of the nitrate assimilatory genes in *S. coelicolor* (*nnaR*, *narK*, *nasA*, *nirBD*) is activated by GlnR under general nitrogen limitation. However, expression of nitrate assimilatory genes is enhanced by the synergistic binding of NnaR and GlnR in the presence of nitrate (Amin et al. 2012). Remarkably, a *nnaR* mutant showed a defect in aerial mycelium and spore formation, as well as in antibiotic production on defined solid medium supplemented with different nitrogen sources (Amin et al. 2012). This result indicates direct or indirect association of the NnaR regulator with secondary metabolite production not only during growth on nitrate.

Regulation of nitrogen metabolism in *S. coelicolor* is very complex and, depending on the conditions, involves additional control by other regulators, such as GlnRII (Fink et al. 2002), PhoP (Martin et al. 2011; Rodriguez-Garcia et al. 2009;

Santos-Beneit 2015; Sola-Landa et al. 2013; Wang et al. 2012), Crp (Gao et al. 2012), AfsR (Santos-Beneit et al. 2012), AfsQ1 (Wang et al. 2013), and ArgR (Perez-Redondo et al. 2012). Involvement of such regulation results in a fine-tuning of the nitrogen metabolism to the physiological requirements of the cell during growth and secondary metabolite production. PhoP exerts its negative control on the transcription of *glnR*, *glnA*, *glnII*, and *amtB-glnK-glnD* upon phosphate limitation (Rodriguez-Garcia et al. 2009). Crp plays an important role at the interface of primary and secondary metabolism. This pleiotropic regulator controls few genes from the nitrogen metabolism, including *glnA*, *glnII*, and *amtB-glnK-glnD* but not *glnR* (Gao et al. 2012). Crp also contributes directly to the regulation of multiple antibiotic clusters in *S. coelicolor* as well as affects the expression of enzymes needed for their precursor supply (Gao et al. 2012). AfsR is a positive regulator of actinorhodin and undecylprodigiosin biosynthesis in *S. lividans* and *S. coelicolor*. AfsR regulates expression of GlnR in the response to unknown nutrient stress stimulus adjusting thereby nitrogen metabolism during secondary metabolite production (Santos-Beneit et al. 2009a, b, 2011a, b, 2012). In *S. coelicolor*, the availability of glutamate is recognized by the two-component system AfsQ1-AfsQ2. AfsQ1 is a pleiotropic regulator involved in the control of actinorhodin, undecylprodigiosin, and CDA production via the direct transcriptional activation of the pathway-specific regulatory genes *actII-ORF4*, *redZ*, and *cdaR* encoding regulators for antibiotic biosynthesis (Chen et al. 2016; Wang et al. 2013). Moreover, AfsQ1 is implicated in the regulation of the nitrogen, carbon, and phosphate metabolism in the presence of glutamate (Wang et al. 2013). Glutamate is a key nitrogen precursor of many secondary metabolites and the most abundant intracellular metabolite in *S. coelicolor* described as a “trigger of metabolic switching” (Borodina et al. 2005; Nieselt et al. 2010; Wentzel et al. 2012a, b).

Regulation of nitrogen metabolism occurs not only on the transcriptional level; few examples of posttranslational regulation have also been described. In *S. coelicolor*, the posttranslational control of ammonium uptake is achieved by the interaction of GlnK—nitrogen sensor protein PII—with the ammonium transporter AmtB in dependence of ammonium level. GlnK is inactivated by the GlnD-mediated adenylation or specific proteolysis (removal of the three N-terminal amino acids) in response to high ammonium concentrations (Reuther and Wohlleben 2007). So far, it is not clear to what target the GlnK/GlnD system transfers its signal to. Deletion of GlnK resulted in the medium-dependent bald phenotype (no aerial mycelium or spores were formed) and abolished actinorhodin production (Waldvogel et al. 2011). Comparative transcriptomic analysis confirmed involvement of GlnK in the regulation of nitrogen metabolism and morphological differentiation, as well as secondary metabolite production in *S. coelicolor* M145 (Waldvogel et al. 2011). Another example of regulation on the posttranslational level was described for the glutamine synthetase GSI. The regulation of GSI occurs via the bifunctional adenylyltransferase GlnE, which is responsible for the reversible adenylation and deadenylation, depending on the nitrogen status of the cell (Reuther and Wohlleben 2007; Fink et al. 1999). Recently, also acetylation of GSI was reported for *S. erythraea* (You et al. 2016). The acetylation of GSI in *S. erythraea* did not influence enzyme

activity but modulated its interaction with the regulator GlnR and enhanced GlnR-DNA binding to the target promoter (You et al. 2016). Interestingly, posttranslational modifications of the GlnR regulator, such as phosphorylation and acetylation, influenced the GlnR-DNA binding and consequently expression of GlnR target genes under physiologically relevant conditions in *S. coelicolor* (Amin et al. 2016).

## 8.4 Influence of Nitrogen Sources on the Regulation of Secondary Metabolite Production

The nature and concentration of the nitrogen source are crucial for the regulation of secondary metabolite production in *Actinobacteria*. Ammonium is the preferred nitrogen source for most *Actinobacteria*. It can easily be assimilated by the glutamate dehydrogenase (GDH) at high ammonium concentrations or at lower ammonium concentration by the GS-GOGAT consisting of glutamine synthetase(s) (GSI, GSII) and glutamate synthetase (GOGAT). Almost all *Actinobacteria* possess both GDH and GS-GOGAT. Alternatively, ammonium can be assimilated via the cooperative activity of an alanine dehydrogenase (ADH) and an alanine transaminase (AT) (Novák et al. 1997) present additionally in the GDH and GS-GOGAT pathways. This has been shown for *S. venezuelae* (Shapiro and Vining 1983), *S. noursei* (Gräfe et al. 1977), *S. fradiae* (Vancura et al. 1989), *S. hygroscopicus* (Chipeva et al. 1991), *S. aureofaciens* (Vancurova et al. 1989), *S. clavuligerus* (Aharonowitz and Friedrich 1980), and *S. erythreus* (Roszkowski et al. 1969). However, not all ammonium assimilation systems are required simultaneously (Brana and Demain 1988).

Although the presence of high ammonium concentrations generally positively correlates with the growth rate, ammonium usually represses utilization of alternative nitrogen sources and delays the onset of secondary metabolite production. Thus, exhaustion of ammonium favors a lower growth rate and stimulates antibiotic production in many species including *S. hygroscopicus* (Chipeva et al. 1991), *S. pristinaespiralis* (Voelker and Altaba 2001), *S. noursei* (Jonsbu et al. 2000), *S. flocculus* (Wallace et al. 1990), *S. venezuelae* (Shapiro and Vining 1983, 1984), *S. lactamadurans* (Cortes et al. 1984), and others (Table 8.3). The repressing effect of ammonium ions could be successfully reduced by the addition of various ammonium-trapping agents, such as  $\text{Mg}_3(\text{PO}_4)_2 \times 8\text{H}_2\text{O}$  and  $\text{Ca}_3(\text{PO}_4)_2$  resulting in an increased production of different secondary metabolites, for example, spiramycin (Untrau et al. 1992; Lounes et al. 1995), streptonigrin (Wallace et al. 1990), gilvocarcin (Byrne and Greenstein 1986), tylosin (Masuma et al. 1983), cephalosporin (Brana et al. 1985), leucomycin (Omura et al. 1980), and nanaomycin (Tanaka et al. 1984). The mechanism of ammonium repression was elucidated for the biosynthesis of tylosin in *S. fradiae* and spiramycin in *S. ambofaciens* (Lebrihi et al. 1992; Lounes et al. 1996a). In both cases, ammonium directly inhibited the activity of enzymes involved in the catabolism of amino acids such as valine, threonine, leucine, and isoleucine, decreasing the precursor pool required for antibiotic biosynthesis. However, in some rare cases, the presence of high ammonium concentrations may favor the antibiotic production. For instance, production of the

**Table 8.3** Examples of nitrogen source-controlled secondary metabolite production in *Actinobacteria*

Secondary metabolite	Producer	Optimal concentration of the preferred nitrogen source	Regulated target	References
2-Methylheptyl isonicotinate	<i>Streptomyces</i> sp. 201	Asparagine 7 mM	NR (not reported)	Thakur et al. (2009)
AK-111-81	<i>S. hygroscopicus</i>	Ammonium succinate 10 mM	NR	Gesheva et al. (2005)
Antifungals	<i>S. aburaviensis</i> var. <i>ablastimyceticus</i> (MTCC 2469)	Asparagine 14 mM Ammonium nitrate 16 mM	NR	Raytapadar and Paul (2001)
Armentomycin	<i>S. armentosis</i>	Lysine 40–120 mM	NR	He et al. (1995)
Avermectin	<i>S. avermitilis</i>	Ammonium sulfate 11 mM	NR	Cimburková et al. (1988)
Avilamycin	<i>S. viridochromogenes</i>	Ammonium sulfate 10 mM	NR	Zhu et al. (2007)
Azalomycin B	<i>S. hygroscopicus</i>	Sodium nitrate 30 mM	NR	Jiang and Huang (2004)
Cephameycin C	<i>S. lactamidurans</i>	Ammonium 1 mM Asparagine 10 mM	NR	Cortes et al. (1984)
Cephameycin C	<i>S. catleya</i>	Asparagine 15 mM	NR	Khaoua et al. (1991)
Clavulanic acid	<i>S. clavuligerus</i>	Ammonium salts 0.6 mM	NR	Visser-Luirink et al. (2006)
Clavulanic acid	<i>S. clavuligerus</i>	Arginine 5 mM Ornithine 0.9 mM	NR	Chen et al. (2003)
Erythromycin	<i>S. erythraea</i>	Sodium nitrate 117 mM	NR	Stocks and Thomas (2001)
Fruilimicin	<i>A. friuliensis</i>	Arginine 9.5 mM + valine 8.5 mM	NR	Steinkämper et al. (2015)
Fungichromin	<i>S. padanus</i> PMS-702	Glutamate 34 mM	NR	Huang et al. (2007)
Gilvocarcin	<i>S. arenae</i> 2064	Ammonium sulfate 1.5 mM Aspartate 7.5 mM Glycine 13 mM	NR	Byrne and Greenstein (1986)

(continued)



Table 8.3 (continued)

Secondary metabolite	Producer	Optimal concentration of the preferred nitrogen source	Regulated target	References
Kanamycin	<i>S. kanamyceticus</i> M27	Sodium nitrate 60 mM	NR	Basak and Majumdar (1975)
Leucomycin	<i>S. kitasatoensis</i>	Ammonium salts 1 mM	NR	Omura et al. (1980)
Lincomycin	<i>S. lincolnensis</i>	Sodium nitrate 2.9 mM	NR	Young et al. (1985) and Lee et al. (2014)
Lincomycin	<i>S. lincolnensis</i>	Sodium nitrate excess	NR	Jin and Jiao (1997)
Lividomycin	Lividomycin producer M814	Sodium nitrate excess	NR	Zhou and Wang (1995)
Magnamycin	<i>S. halstedii</i>	Potassium nitrate 30 mM Cystine 8 mM Beta-alanine, 11 mM	NR	Ghonaim et al. (1980)
Meroparamycin	<i>Streptomyces</i> sp. MAR01	Sodium nitrate 10–20 mM	NR	El-Naggag et al. (2006)
NAI-107 lanthibiotic	<i>Microbispora</i> sp. ATCC-PTA-5024	Ammonium nitrate 25 mM Sodium nitrate 50–100 mM Ammonium chloride 50–100 mM	NR	Giardina et al. (2014) Bera and Walter (to be published)
Natamycin	<i>S. natalensis</i>	Sodium nitrate Ammonium sulfate Beef extract 8 g/L	NR	Farid et al. (2000)
Neocarzinostatin	<i>S. carzinostaticus</i> F-41	Asparagine and threonine	NR	Kudo et al. (1993)
Niromycin	<i>S. endus</i> N40	Asparagine 11 mM	NR	El-Shirbiny et al. (2007)
Oleandomycin	<i>S. antibioticus</i>	Aspartate 15 mM	NR	Vilches et al. (1990)
Polyketide antibiotic SBR-22	<i>Streptomyces</i> BT-408	Ammonium nitrate 125 mM	NR	Sujatha et al. (2005)
Pristinamycin	<i>S. pristinaespiralis</i>	Glutamate 88 mM	NR	Voelker and Altaba (2001)

Pyrazoloisoquinoline (APHE-1 to APHE-4)	<i>S. griseocarneus</i> NCIMB 40447	Lysine 13–14 mM	NR	Cruz et al. (1999)
Pyroindomycin	<i>S. rugosporus</i> LL-42D005	Arginine 20 mM + casein 5 g/L	NR	Abbanat et al. (1999)
Rapamycin	<i>S. hygroscopicus</i>	Ammonium sulfate 40 mM	NR	Lee et al. (1997)
Rifamycin B	<i>A. mediterranei</i> NCH	Potassium nitrate 178 mM	NR	El-Tayeb et al. (2004)
Rifamycin SV	<i>A. mediterranei</i>	Potassium nitrate 80 mM	NR	Shao et al. (2015a, b)
Simocyclinone	<i>S. antibioticus</i> Tü 6040	Glutamine 40 mM	NR	Schimana et al. (2001)
Simocyclinone	<i>S. antibioticus</i> Tü 6040	Lysine 20 mM Lysine	NR	Theobald et al. (2000)
Spiramycin	<i>S. ambofaciens</i>	Valine 50 mM	Valine dehydrogenase	Untrau et al. (1994), Lebrühi et al. (1992), and Lounes et al. (1995)
Tylosin	<i>S. fradiae</i>	Valine, leucine, isoleucine, threonine, 10 mM each	Aspartate aminotransferase Valine dehydrogenase Threonine dehydratase	Lee and Lee (1993), Omura et al. (1984), Lee (1997), and Vu-Trong and Gray (1987)
Viridomycin	<i>S. griseus</i>	Alanine 11 mM	NR	Kurobane et al. (1987)

ribosomally synthesized lantibiotic NAI-107 in *Microbispora* sp. ATCC-PTA-5024 is strongly stimulated by ammonium in a concentration range between 50 and 100 mM, whereas limitation of this nitrogen source completely abolished NAI-107 production (Bera and Walter to be published).

Instead of ammonium, nitrate can be assimilated by *Actinobacteria* as an alternative nitrogen source. Interestingly, not nitrate depletion but nitrate excess enhances secondary metabolite production in *Actinobacteria*—referred to as a “nitrate stimulating effect” (Jiao et al. 1979; Shao et al. 2015a). For instance, addition of 80 mM or 178 mM potassium nitrate into the fermentation medium reduced the growth rate and remarkably stimulated production of the rifamycin SV in *A. mediterranei* U32 (Shao et al. 2015a, b) and rifamycin B in *A. mediterranei* NCH (El-Tayeb et al. 2004), respectively. The “nitrate stimulating effect” was extensively investigated on the transcriptional and metabolic level in *A. mediterranei*. The presence of nitrate positively influenced expression of genes encoding enzymes involved in glycolysis, pentose phosphate pathway, and tricarboxylic acid cycle, leading to the enhanced acetyl-CoA production simultaneously resulting in a shift of the malonyl-CoA flux from the fatty acid biosynthesis to rifamycin SV biosynthesis (Shao et al. 2015b). A similar “nitrate stimulating effect” was shown in the production of the polyketide antibiotic SBR-22 in *Streptomyces BT-408*. However, in this case instead of potassium nitrate, ammonium nitrate was added to the fermentation medium (Sujatha et al. 2005). Nitrate was also the best nitrogen source for lincomycin, lividomycin, azalomycin B, meroparamycin, magnamycin, erythromycin, and MSW2000 production (Table 8.3), but the molecular mechanism of this nitrate-mediated stimulation has not been investigated so far.

Amino acids, especially glutamate, are also a very important source of nitrogen for the production of secondary metabolites. Glutamate catabolism involves the activity of the catabolic glutamate dehydrogenase (GdhB) resulting in the generation of alpha-ketoglutarate subsequently incorporated into the TCA cycle (Kim and Kim 2016). GdhB and glutamate utilization have been shown to interfere with *N*-acetylglucosamine metabolism governed by the transcriptional regulator DasR (Rigali et al. 2008), participating in the onset of secondary metabolism in *S. coelicolor* (Kim and Kim 2016). Elimination of the assimilatory glutamate dehydrogenase (GdhA) caused enhanced activity of GdhB and intracellular accumulation of alpha-ketoglutarate in *S. tsukubaensis* resulting in a shift of metabolic flux that enhanced tacrolimus biosynthesis (Huang et al. 2013). Glutamate can be utilized as nitrogen or carbon source and is preferred as a carbon source over glucose. It favors growth, as well as antibiotic production in *S. coelicolor* (van Wezel et al. 2005; Wentzel et al. 2012a) and *S. lividans* (D’Huys et al. 2011). Production of pristinamycin in *S. pristinaespiralis* was positively influenced by glutamate and arginine. However, glutamate was first consumed, and then glucose and arginine were used, indicating that glutamate was mainly used as an energy source (Voelker and Altaba 2001).

The nature and the concentration of amino acids used as a nitrogen source may enhance or affect antibiotic production depending on the secondary metabolite biosynthetic pathway and the host. For example, spiramycin production was positively influenced by lysine, isoleucine, and valine. But one amino acid, threonine, completely abolished spiramycin production in *S. ambofaciens* (Lebrihi et al. 1992).

However valine, leucine, isoleucine, and threonine have been shown to be good nitrogen sources for the production of tylosin in *S. fradiae*. Production of pyrazoloisoquinolinone antibiotics (APHE) was greatly enhanced by lysine, but supplementation of the production medium with histidine completely abolished APHE production in *S. griseocarneus* (Cruz et al. 1999). The influence of particular amino acids on antibiotic biosynthesis is determined by the chemical structures of the antibiotic itself, regulation of the biosynthetic pathway, and metabolic potential of the producing strain. Some amino acids can be directly incorporated in antibiotic molecules as precursors, or their amino groups can be transferred to specific intermediate products (Aharonowitz and Friedrich 1980; Cheng et al. 1995; Doull and Vining 1990; Martin and Demain 1980; Omura and Tanaka 1986).

While different nitrogen sources may stimulate or inhibit antibiotic production, general nitrogen limitation leads to activation of a global stringent response resulting in onset of antibiotic production. Nitrogen (and also glucose) limitation elicits global stringent response leading to an increased production of the alarmone (p)ppGpp. Under amino acids or glucose starvation, (p)ppGpp levels are controlled by the *relA* gene product. RelA is a bifunctional enzyme conferring both (p)ppGpp synthetase and hydrolase activities (Chakraborty and Bibb 1997). RelA deletion mutants were unable to produce antibiotics, actinorhodin, and undecylprodigiosin, as well as the stringent factor (p)ppGpp in *S. coelicolor* (Chakraborty et al. 1996). However, negative regulation of secondary metabolite biosynthesis by (p)ppGpp in a *S. clavuligerus* was also demonstrated. Although the *relA* deletion mutant in *S. clavuligerus* was affected in morphological differentiation and (p)ppGpp biosynthesis, production of antibiotics (clavulanic acid and cephamycin C) increased markedly compared to the wild type (Gomez-Escribano et al. 2008).

---

## 8.5 Signaling Molecules Governing Antibiotic Biosynthesis

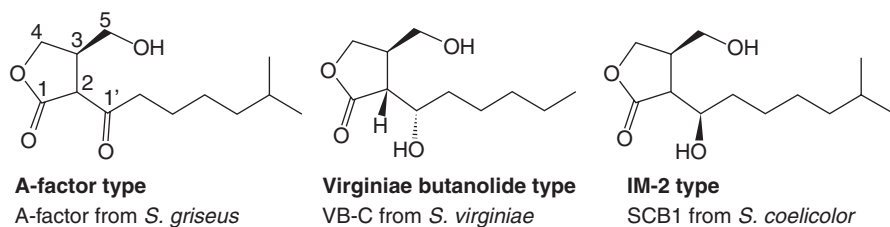
As described above (Sects. 8.2–8.4), antibiotic production in *Actinobacteria* can be influenced by many different physiological signals. The pathway-specific regulation of antibiotic biosynthesis most often is guided by organic low-molecular-weight compounds, such as  $\gamma$ -butyrolactones (GBLs). Thereby, the regulation principles are similar to those of the *N*-acylhomoserine lactone-driven quorum-sensing system in Gram-negative bacteria (Polkade et al. 2016). Quorum sensing is known to play a major role in the regulation of secondary metabolite production and/or morphogenesis in the phylum *Actinobacteria*, which constitutes one of the largest phyla among *Bacteria*. However, so far only 9 (2.6%) of 342 genera have proven experimental evidence for the use of quorum-sensing regulation systems, including *Actinoplanes*, *Amycolatopsis*, *Bifidobacterium*, *Kitasatospora*, *Leifsonia*, *Micromonospora*, *Mycobacterium*, *Propionibacterium*, and *Streptomyces*. Thereby, it is apparent that most of what is known about quorum sensing in *Actinobacteria* comes from studies of antibiotic-producing taxa, whereby the residual genera within the phylum are not explored extensively (Polkade et al. 2016). Due to this, we here will concentrate on the regulation processes in the well-studied antibiotic-producing genus *Streptomyces*.

### 8.5.1 $\gamma$ -Butyrolactone Signaling

GBL molecules trigger secondary metabolite synthesis in streptomycetes by a hormonelike modulatory *mechanism*. GBLs are synthesized during the early exponential growth phase. They diffuse freely through the cellular membrane and gradually accumulate in a growth-dependent manner, reaching their maximum concentration at about  $\sim 100$  nM at or near the middle of exponential phase (Horinouchi and Beppu 2007). When the GBL concentration reaches a certain critical threshold (which can lie between 1 and 1000 nM according to the antibiotic-producing organism) (Yang et al. 2015), a quorum sensing-like signaling cascade is switched on in an all-or-nothing principle, which affects the streptomycetal physiological and/or morphological differentiation. At least 60% of all *Streptomyces* species are suggested to produce GBLs (Yamada 1995), whereby phylogenetic analyses suggest that the actual number is even larger (Polkade et al. 2016). This corresponds to the finding from a BLAST analysis that each of nine *Streptomyces* genomes had one to three GBL synthase (*afsA*)-like genes, indicating that GBL effectors are a near-universal feature of streptomycetes (Niu et al. 2016).

Although the first GBL was described already  $\sim 50$  years ago (Khokhlov et al. 1967), still relatively little is known about the biological function and the synthesis of these hormonelike molecules in streptomycetes. To date, up to 20 GBL-like signaling molecules have been identified in different *Streptomyces* species, including *S. griseus*, *S. virginiae*, *S. coelicolor*, *S. lavendulae*, and *S. rochei* (Willey and Gaskell 2011; Takano et al. 2000; Arakawa et al. 2012). All GBL-like molecules have a characteristic 2-(1'-oxo or 1'-hydroxyalkyl)-3-hydroxymethylbutyrolactone skeleton. Due to minor differences in the chemical structure, they have been classified into three major groups based on the length and branching of the alkyl side chain and the reduction state and stereochemistry of the hydroxyl group at C-1 of the alkyl side chain: the A-factor type (1'-keto type) (e.g., A-factor from *S. griseus*), the virginiae butanolide type ((1'S)-hydroxy type) (e.g., VB-A-E from *S. virginiae*), and the IM-2 type ((1'R)-hydroxy type) (e.g., IM-2 from *S. lavendulae*, SCB1 from *S. coelicolor*) (Martín and Liras 2010) (Fig. 8.1).

Besides the abovementioned GBL-like substances, also chemically different small molecules have been found to act as signaling molecules, such as methylenomycin furan in *S. violaceoruber* and *S. coelicolor*, which induce methylenomycin production; avenolide in *S. avermitilis*, which induces avermectin biosynthesis; or

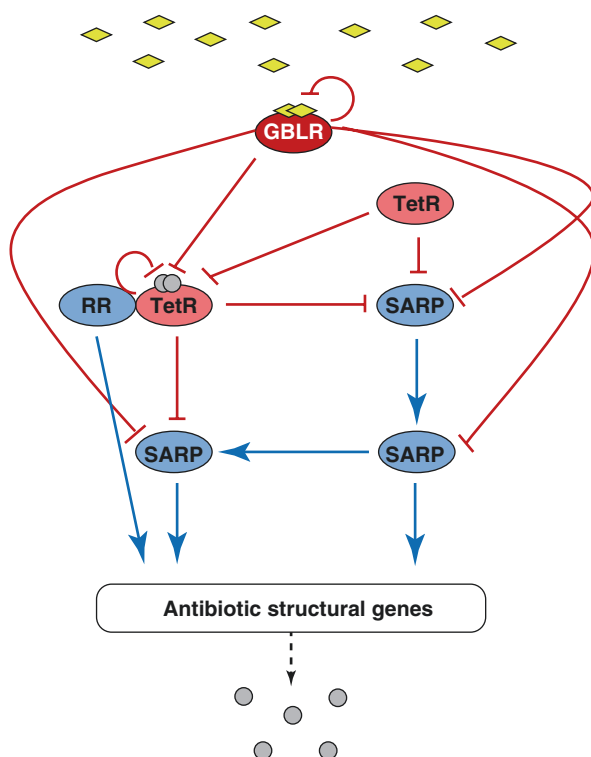


**Fig. 8.1** Chemical structure of different representatives of the three major groups of  $\gamma$ -butyrolactones

PI factor from *S. natalensis*, which induces primaricin production (Yamada 1999; Martín and Liras 2010). Thus, signaling is not only restricted to GBL-like molecules but also to chemically different substances.

However, all hormonelike effector molecules act in a similar mechanistic manner: They bind to their cognate receptor protein, which generally is a TetR-like protein that—in the absence of effector molecules—represses the transcription of its target gene(s). In the presence of a sufficient amount of signaling molecules, an effector/receptor complex is formed, which dissociates from the promoter region(s) of the respective target gene(s) and thus allows expression of the derepressed gene(s). Well-known examples for such an interaction are ArpA from *Streptomyces griseus* that senses the A-factor (Onaka and Horinouchi 1997), BarA from *S. virginiae* that binds virginiae butalones (Kinoshita et al. 1997), JadR3 sensing SVB1 in *S. venezuelae* (Zou et al. 2014), FarA binding IM-2 in *S. lavendulae* (Kitani et al. 1999), or AvaR1 sensing avenones in *S. avermitilis* (Kitani et al. 2011). The receptor protein generally acts as a superordinate regulator controlling the transcription of other regulatory gene(s), which in the end results in a hierarchical structured signaling cascade that drives the antibiotic biosynthesis (shown exemplarily in Fig. 8.2). The lowest end of the signaling cascade is characterized by (a) pathway-specific regulator(s) that directly activate(s) the transcription of the antibiotic biosynthetic genes, which ultimately leads to antibiotic production (Bignell et al. 2007; Suzuki et al. 2010; Mast et al. 2015).

**Fig. 8.2** Schematic model for antibiotic signaling cascade. Regulators are represented by ellipses. *GBLR*  $\gamma$ -butyrolactone receptor, *TetR* TetR-like regulator, *SARP* SARP-type regulator, *RR* response regulator. GBLs are indicated as yellow diamonds. Antibiotic and/or intermediates are shown as gray spheres. Arrows indicate transcriptional activation, perpendicular lines represent transcriptional repression. Dashed line illustrates antibiotic (intermediate) production



## 8.5.2 Antibiotics as Signaling Molecules

Interestingly, it was found that streptomycetes often harbor multiple putative GBL receptor homologues, which do not sense GBLs as effector molecules but instead antibiotics or intermediates thereof. Thus, these receptors were designated as “pseudo”-GBL receptors (Xu et al. 2010; Wang et al. 2011). Examples include ScbR2 from *S. coelicolor*, which binds actinorhodin and undecylprodigiosin as effectors (Wang et al. 2011), JadR2 from *S. venezuelae* which senses jadomycin and chloramphenicol (Zou et al. 2014), and Aur1R from *S. aureofaciens* which binds auricin as a ligand (Novakova et al. 2010). The suggested role of pseudo-GBL receptors is to coordinate antibiotic biosynthesis by binding and responding to antibiotics as signals (Xu et al. 2010). Thereby, the antibiotics act as autoregulators in a similar mechanistic way as the GBLs and control their own biosynthesis. Interestingly, some of these pseudo-GBL receptors can bind more than one and structurally different antibiotics implying that there is a cross-regulation between different biosynthetic pathways via these receptor proteins (Niu et al. 2016). The genes encoding pseudo-GLB receptors are usually under control of real GBL receptors. Occasionally, pseudo-GBL receptors are directly involved in the regulation of GBL biosynthesis, as they bind to the promoters of GBL biosynthetic genes (Wang et al. 2011). Thus, there is obviously a tight and highly coordinated interplay between different types of effectors that influence antibiotic biosynthesis, which involves feedback, as well as feed-forward mechanisms of regulatory control (Kormanec et al. 2014; Foulston and Bibb 2011).

However, not only GBL-receptor-type regulators have been found to sense antibiotics as ligands but also pathway-specific so-called “atypical” response regulators, such as RedZ from *S. coelicolor*, which binds undecylprodigiosin; JadR1 from *S. venezuelae*, which binds jadomycin (Wang et al. 2009); SimReg1 from *Streptomyces antibioticus*, which senses simocyclinone (Horbal et al. 2012); or SsaA from *Streptomyces* sp. SS, a more unique type of transcriptional regulator, that recognizes sansanmycin (Li et al. 2013). Thereby, the secondary metabolites act as autoregulators of their own biosynthesis and by binding to the response regulator abolish the transcriptional activation process (of antibiotic biosynthesis and/or resistance genes) in a concentration-dependent manner (Wang et al. 2009). Actually, the response to antibiotic signals may not only be transmitted by the transcriptional regulators alone but may also involve sigma factor/anti-sigma factor pairs that induce feed-forward antibiotic biosynthesis, for example, reported for microbisporicin production in *Microbispora corallina* (Foulston and Bibb 2011). Altogether, this unveils that regulation of antibiotic biosynthesis is highly complex and employs different types of effectors and transcriptional regulators.

## 8.5.3 Interspecies Signaling in Streptomycetes

A lot of research studies deal with a specific regulatory mechanisms in a given antibiotic-producing strain. However, only very few studies cover comprehensive regulatory networks that control antibiotic biosynthesis. The best investigated

system so far is the A-factor signaling cascade, which triggers streptomycin production as well as morphological differentiation in *S. griseus* (Horinouchi 2002; Horinouchi and Beppu 2007). Interestingly enough, there are several evidences by now that *Streptomyces*-derived antibiotic effectors can also serve as interspecies signaling molecules (Nodwell 2014), e.g., GBLs from different *Streptomyces* species have been found to resemble identical chemical structures (e.g., SVB1 from *S. venezuelae* and SCB1 from *S. coelicolor* (Zou et al. 2014)) implying that the respective effector producers can signal to each other. Besides, it has been shown that a given pseudo-GBL receptor can sense antibiotics from different *Streptomyces* species (ScbR2 from *S. coelicolor*, which normally senses actinorhodin and undecylprodigiosin, binds jadomycin—an antibiotic from *S. venezuelae* (Wang et al. 2014)), meaning that there is a cross talk between different antibiotic biosynthetic pathways. Overall, these few examples only allow a glimpse into the interwoven and interacting signaling machinery that influences antibiotic production and indicates that regulation of antibiotic biosynthesis is far more complex than previously thought. In future studies, such interactions might be elucidated with more advanced methods, for example, MS/MS-based networking techniques that enable the interrogation of specialized metabolites directly from microbial colonies (Fang and Dorrestein 2014).

## 8.5.4 Positive Control Mechanisms

Transcriptional activation of antibiotic biosynthetic genes can either occur through promoter eliciting activation upon binding of an appropriate signal to its cognate regulator or by a direct activation of the target gene(s) through a transcriptional activator protein. Hereby, the transcriptional activators generally act by either stabilizing the RNA polymerase-promoter complex or accelerating the transition of the open complex during *transcription* initiation (Romero-Rodríguez et al. 2015).

### 8.5.4.1 Two-Component Systems

Known activators of antibiotic biosynthesis include response regulators of two-component systems. Two-component systems consist of a sensor kinase that, in response to an effector molecule, phosphorylates and thereby activates a cognate response regulator, which in turn activates (or sometimes represses) the transcription of its target gene(s). Usually, the genes encoding the sensor kinase and the response regulator are co-localized. One example is represented by the two-component system AfsQ1-AfsQ2 from *S. coelicolor*, consisting of the sensor kinase AfsQ2 and the response regulator AfsQ1. Here, AfsQ1 has been shown to directly activate the coelimycin P2 (yCPK) biosynthetic genes and indirectly stimulate the production of actinorhodin, undecylprodigiosin, and the calcium-dependent antibiotic via activation of the respective pathway-specific regulator genes (*actII-ORF4*, *redZ*, and *cdaR*, respectively) (Wang et al. 2012; Chen et al. 2016). However, in the meanwhile also numerous examples are known for functional unpaired, so-called “orphan” or “atypical” response regulators that activate antibiotic gene transcription



(see Sect. 8.5.2), which suggests that these regulators are a more abundant phenomenon in antibiotic-producing streptomycetes. Thus, the term “orphan”—even if it is meant in relation to “response regulator”—may not be the most appropriate one.

#### 8.5.4.2 One-Component Systems

Actually, the predominant signal transduction systems in prokaryotes are represented by one-component systems (Ulrich et al. 2005). Such one-component system activators of antibiotic biosynthesis in streptomycetes include transcriptional regulators that belong to the family of LuxR-, SARP-, AraC/XylS-, or LysR-type regulators. Hereby, the sensor domain of the activator recognizes the effector molecule (except for the SARPs, which are not known to sense signals), whereas the DNA-binding domain binds to the promoter region of the target DNA and thereby activates gene transcription. Due to the significance of SARP-type regulators for the activation of diverse antibiotic biosyntheses, we here will concentrate only on this regulator type.

#### SARPs

One of the most prominent families of pathway-specific transcriptional activators is represented by the *Streptomyces* antibiotic regulatory proteins (SARPs); e.g., SARP genes were found within almost all biosynthetic gene clusters governing aromatic polyketide production (Rebets et al. 2008). This regulator type is rather phylum specific, since so far, SARPs have only been found in *Actinobacteria* and actually most of them are within streptomycetes (Romero-Rodríguez et al. 2015). Here, they generally act at the end of the signaling transduction cascade and directly activate the transcription of the antibiotic biosynthetic genes.

So far, numerous representatives of SARP-type regulators and their regulatory role have been described, such as ActII-ORF4 and RedD, which activate *actinorhodin* and undecylprodigiosin production in *S. coelicolor*, respectively (Chakraborty and Bibb 1997); TylS and TylT, inducing tylosin production in *S. fradiae* (Cundliffe 2006); PapR1, PapR2, and PapR4 that activate pristinamycin biosynthesis in *S. pristinaespiralis* (Mast et al. 2015; Mast and Wohlleben 2014); VmsS and VmsR inducing virginiamycin biosynthesis in *S. virginiae* (Pulsawat et al. 2009); or Aur1PR2 and Aur1PR3, which activate auricin biosynthesis in *S. aureofaciens* (Novakova et al. 2011) (Table 8.4). SARPs are characterized by a N-terminal bacterial transcriptional activation domain (BTAD) consisting of seven  $\alpha$ -helices and a C-terminal OmpR-like DNA-binding domain, which is predicted to interact with the major groove of the DNA (Wietzorrek and Bibb 1997; Tanaka et al. 2007). The SARP regulator induces gene transcription by binding to a tandemly arrayed set of heptameric repeats within the promoter region of the target gene. Hereby, the SARPs specifically bind to direct repeat sequences (5'-TCGAGSS-3') ~8 bp upstream of the -10 promoter element of the target genes and thereby overlap with the -35 region. As the -35 region normally is the binding site for transcriptional repressors and not activators, the SARP-driven transcriptional activation is suggested to occur via a unique mechanism: The SARP-specific repeat sequences are separated from each other by 11 or 22 bp, which corresponds to one or two turns of the DNA helix,

**Table 8.4** Examples for some prominent families of pathway-specific transcriptional regulators in *Streptomyces* species (for a detailed overview, see Romero-Rodríguez et al. 2015)

Family	HTH domain	Regulator	Antibiotic	Origin	Consensus binding motif (5'→3')	Reference
<i>(A) Transcriptional activators of antibiotic biosynthesis</i>						
AraC/XylS	C-terminal	AdpA	Streptomycin, grinoxazone	<i>S. griseus</i>	TGGCSNGWVY	Ohnishi et al. (2005)
		RapG	Rapamycin	<i>S. hygroscopicus</i>		Kuscer et al. (2007)
		TxtR	Thaxtomycin	<i>S. scabies</i>		Joshi et al. (2007)
		NamR4	Nanchangmycin	<i>S. nanchangensis</i>		Yu et al. (2012)
		SgcR2	Enediynes antibiotic C-1027	<i>S. globisporus</i>		Chen et al. (2010)
PAS-LuxR	N-terminal	PimM	Pimaricin	<i>S. natalensis</i>	CTVGGGAW WTCCCBAG	Antón et al. (2007)
		SenRII	Natamycin	<i>S. chattanoogaensis</i>		Du et al. (2009)
		AURJ3M	Aureofuscin	<i>S. aureofuscus</i>		Wei et al. (2011)
		CfaR	Coronafacoyl phytotoxin	<i>S. scabies</i>		Cheng et al. (2015)
		LAL (LuxR subfamily)	N-terminal	PimR		Pimaricin
FkbN	FK506 (tacrolimus)			<i>S. tsukubaensis</i>	Goranović et al. (2012)	
SanG	Nikkomycin			<i>S. ansochromogenes</i>	He et al. (2010)	
PolR	Polyoxin			<i>S. cacaoi</i>	Li et al. (2009)	
PteR	Filipin			<i>S. avermitilis</i>	Vicente et al. (2014)	
RapH	Rapamycin			<i>S. hygroscopicus</i>	Kuscer et al. (2007)	
AveR	Avermectin			<i>S. avermitilis</i>	Guo et al. (2014)	
ThnI	Thienamycin			<i>S. cattleya</i>	Rodríguez et al. (2008)	
FkbR	FK506 (tacrolimus)			<i>S. tsukubaensis</i>	Goranović et al. (2012)	
ClaR	Clavulanic acid			<i>S. clavuligerus</i>	Pérez-Redondo et al. (1998)	

(continued)

Table 8.4 (continued)

Family	HTH domain	Regulator	Antibiotic	Origin	Consensus binding motive (5'→3')	Reference		
SARP	N-terminal	ActII-Orf4	Actinorhodin	<i>S. coelicolor</i>	TCGAGXX	Arias et al. (1999)		
		PapR1, PapR2, PapR4	Pristinamycin	<i>S. pristinaespiralis</i>	TCGAGCC/G	Mast et al. (2015)		
		RedD	Undecylprodigiosin	<i>S. coelicolor</i>		Narva et al. (1990)		
		TyIT, TyIS	Tylosin	<i>S. fradiae</i>		Cundliffe (2006)		
		VmsR, VmsS	Virginiamycin	<i>S. virginiae</i>		Pulsawat et al. (2009)		
		NanR1, NanR2	Nanchangmycin	<i>S. nanchangensis</i>		Yu et al. (2012)		
		SrrW, SrrY, SrrZ,	Lankamycin, lankacidin	<i>S. rochei</i>		Arakawa et al. (2007)		
		AurIPR2, AurIPR3	Auricin	<i>S. aureofaciens</i>		Novakova et al. (2011)		
		AlpT, AlpU, AlpV	Alpomycin	<i>S. ambofaciens</i>		Aigle et al. (2005)		
		CcaR	Cephamicin, clavulamic acid	<i>S. clavuligerus</i>		Santamarta et al. (2002)		
		Resp. regulator	C-terminal	AurIP	Auricin	<i>S. aureofaciens</i>	TCCTTG	Novakova et al. (2005)
				VmsT	Virginiamycin	<i>S. virginiae</i>		Pulsawat et al. (2009)
		MarR	Central	PapR6	Pristinamycin	<i>S. pristinaespiralis</i>		Mast et al. (2015)
JadR1	Jadomycin			<i>S. venezuelae</i>		Wang et al. (2009)		
PenR	Pentalactone			<i>S. exfoliates</i>		Zhu et al. (2013)		
DeoR	N-terminal	PntR	Pentalactone	<i>S. arenae</i>		Zhu et al. (2013)		
		SdrA	Avermectin	<i>S. avermitilis</i>		Ulanova et al. (2013)		

(B) *Transcriptional repressors of antibiotic biosynthesis*

DeoR	N-terminal	SdrA	Oligomycin, filipin	<i>S. avermitilis</i>		Ulanova et al. (2013)
IcIR	N-terminal	DoxR	Doxorubicin	<i>S. peucetius</i>		Chaudhary et al. (2014)
GntR		PtmR1	Platencin	<i>S. platensis</i>		Yu et al. (2012)
		PtmR1	Platensimycin, platencin	<i>S. platensis</i>		Smanski et al. (2009)
TetR		LndYR	Landomycin	<i>S. globisporus</i>		Ostash et al. (2011)
		SpbR, PapR3, PapR5	Pristinamycin	<i>S. pristinaespiralis</i>	TNANAWACNNA CYNNCCGTTTKTTT	Mast et al. (2015)
		ArpA	Streptomycin	<i>S. griseus</i>		Ohnishi et al. (2005)
		AlpW	Kinamycin	<i>S. ambofaciens</i>		Bunet et al. (2011)
		AlpZ	Alpomycin	<i>S. ambofaciens</i>		Bunet et al. (2011)
		ArpA	Streptomycin	<i>S. griseus</i>		Onaka and Horinouchi (1997)
		Aur1R	Auricin	<i>S. aureofaciens</i>		Novakova et al. (2010)
		AvaR1	Avermectin	<i>S. avermitilis</i>		Kitani et al. (2011)
		BarA	Virginiamycin	<i>S. virginiae</i>		Kinoshita et al. (1997)
		BarB	Virginiamycin	<i>S. virginiae</i>		Matsuno et al. (2004)
		FarA	Showdomycin	<i>S. lavendulae</i>		Kitani et al. (1999)
		TyIP, TyIQ	Tylosin	<i>S. fradiae</i>		Cundliffe (2006)
	MarR		JadR3	Jadomycin	<i>S. venezuelae</i>	
Central		FdmR, FdmR2	Fredericamycin	<i>S. griseus</i> ATCC 49344		Chen et al. (2008)

N = A, C, G, T; V = G, A, C; B = G, T, C; W = A, T; K = G, T; S = G, C; Y = C, T

respectively. According to that, the two repeat sequences appear on the same face of the DNA and are cooperatively bound by two SARP monomers, whereas the RNA polymerase (RNAP) is bound at the opposite site of the DNA helix. This kind of stable ternary DNA-(SARP)<sub>2</sub>-RNAP complex is responsible for the transcriptional initiation (Tanaka et al. 2007).

### Interaction of Multiple Positive Regulators

In a given *Streptomyces* species, more than one SARP-type regulator can be involved in the transcriptional activation of antibiotic biosynthetic genes. In such a case, there is often a central, essential SARP activator, which controls the transcription of the hierarchical subordinate SARP regulator(s), such as SrrY controlling *srrZ* transcription in the lankamycin/lankacidin producer *S. rochei* (Yamamoto et al. 2008), VmsR governing *vmsS* transcription in the virginiamycin producer *S. virginiae* (Pulsawat et al. 2009), or PapR2 guiding *papR1* transcription in the pristinamycin producer *S. pristinaespiralis* (Mast et al. 2015). On the other hand, some of the subordinate regulators are suggested to have a “SARP helper” activity and contribute to transcriptional induction (e.g., PapR1 for pristinamycin production (Mast et al. 2015) or TylU for tylosin production (Bate et al. 2006)). However, there are also cascade examples where no such hierarchical SARP organization is described, for example, for Aur1PR3 and Aur1PR2 involved in auricin production, TylS and TylT involved in tylosin production, or NanR1 and NanR2 responsible for nanchangmycin production (Novakova et al. 2011; Bate et al. 2002; Yu et al. 2012; respectively).

As mentioned above, alongside the SARP-type regulators, there are numerous other transcriptional activators known to induce transcription of antibiotic biosynthetic genes (see above, Table 8.4). All regulatory systems have in common that there is generally one major pathway-specific activator that drives the whole antibiotic biosynthesis. Especially these regulators are of particular interest as they can efficiently be applied either for optimizing antibiotic production processes or for the activation of silent gene clusters in order to identify novel anti-infective agents (see Sect. 8.6).

### 8.5.5 Negative Control Mechanisms

Transcriptional repression of antibiotic biosynthetic genes can occur by binding of a repressor to its target promoter, which prevents access by the RNA polymerase and thereby inhibits transcriptional initiation. Transcription can also be repressed when a repressor competes with an activator for its cognate-binding position within the promoter region or when the repressor binds somewhere downstream of the promoter and thereby prevents elongation of the transcript (Romero-Rodríguez et al. 2015). Repressors of antibiotic biosynthesis in streptomycetes include transcriptional regulators that belong to the family of TetR-, LysR-, DeoR-, GntR-, or MarR-type regulators. Thereof, the TetR family of regulators is the most prominent one represented by more than 100 genes per species (Romero-Rodríguez et al. 2015). Thus, we here will concentrate on the regulatory principles of TetR-type regulators.

TetR-like regulators generally consist of an N-terminal DNA-binding domain with a HTH-motif and a C-terminal ligand-binding domain. In the absence of the cognate ligand, the DNA-binding domains of the TetR-like homodimer bind to AT-rich, symmetric, palindromic DNA sequences. These operator sequences often overlap with the promoter regions of the target genes. Thus, TetR binding to these operator sequences mostly blocks transcription of the genes. Upon binding of the cognate ligand to the C-terminal ligand-binding domain, the TetR-like regulator undergoes a conformational change that renders the repressor unable to bind DNA and thus allows transcription of the target genes (Ramos et al. 2005).

Different types of substances can serve as ligands, such as metals, GBLs, or antibiotics, as described above. The transcription of the antibiotic-related genes can either be released in a more direct way upon ligand-driven derepression of the TetR-like regulator, or additional regulatory genes are interposed so that the signal is transmitted rather indirectly (see Sect. 8.5.6).

An example for a simple ligand-dependent derepression is represented by the TetR-like regulator ActR from *S. coelicolor*, which after binding of *actinorhodin* or its intermediates is released from the promoter of the *actAB* operon encoding two *actinorhodin* exporter pumps. In this way, the binding of the antibiotic (intermediates) to the regulator allows expression of the *actinorhodin* exporters, which may protect the antibiotic-producing organism from self-killing (Xu et al. 2012; Tahlan et al. 2008). In a similar manner, the antibiotic simocyclinone and its intermediate from *S. antibioticus* lead to a derepression of the TetR-like regulator SimR allowing expression of the simocyclinone efflux pump SimX (Le et al. 2009).

### 8.5.6 Hierarchical Signaling Cascades

An example for a rather complex circuit is represented by the streptomycin signaling cascade of *Streptomyces griseus*, where the A-factor binds to its cognate GBL receptor ArpA, which is released from the promoter region of *adpA*. AdpA is a global transcriptional activator and among others activates the transcription of the pathway-specific regulatory gene *strR*, of which the gene product switches on the transcription of the streptomycin biosynthetic genes and thus induces streptomycin biosynthesis (Horinouchi 2002). In such a scenario, the whole signaling cascade controls the antibiotic biosynthesis in a quite intricate manner because all of the interposed regulators can be interfaces for further regulatory interactions (Fig. 8.2). By now, there are several examples for such hierarchical signaling cascades driving antibiotic biosynthesis, such as the regulatory networks controlling tylosin production in *S. fradiae* (Cundliffe 2006), virginiamycin biosynthesis in *S. virginiae* (Matsuno et al. 2004; Pulsawat et al. 2009), pristinamycin biosynthesis in *S. pristinaespiralis* (Mast et al. 2015), auricin production in *S. aureofaciens* (Kormanec et al. 2014), or lankacidin/lankamycin biosynthesis in *S. rochei* (Arakawa et al. 2007). However, a satisfactory paradigm that allows a broadly defined understanding on how such signaling cascades operate is missing so far. Undoubtedly, understanding the principles that guide antibiotic biosynthesis is a

prerequisite for a targeted regulator-based strain engineering in order to increase the production of known antibiotics or to elicit the activation of silent antibiotic gene clusters in order to find new anti-infectives (see Sect. 8.6). Both aspects have been dealt with, e.g., in analyses of the pristinamycin regulatory cascade from *S. pristinaespiralis*. A simple approach to increase antibiotic production is to inactivate cluster-situated repressors and/or overexpress pathway-specific activators. This has successfully been applied for pristinamycin production, where the yield of the antibiotic was increased after overexpressing the SARP activator genes *papR1* and *papR2* (100% more pristinamycin than the wild type) and deleting the TetR-like repressor gene *papR5* (300% more pristinamycin than the wild type) (Mast et al. 2015). Besides that, it was observed that the overexpression of PapR2 in *S. lividans* activates the silent undecylprodigiosin gene cluster (Mast personal communication).

---

## 8.6 Induction of Silent Secondary Metabolite Clusters by Manipulating Gene Regulation

The continuously increasing genome sequencing data have revealed the presence of numerous cryptic pathways in *Actinobacteria*, which might encode novel secondary metabolites with interesting biological activities. However, utilization of this hidden potential has been hindered by the observation that many of these gene clusters remain “silent” (or “cryptic” or poorly expressed) under laboratory conditions. Silent gene clusters are clusters that are implicated in the synthesis of secondary metabolites based on their sequence annotations, but for which the specific individual environmental signal required to trigger natural product biosynthesis is yet unknown. Expression of secondary metabolite clusters is typically under environmental and/or developmental control and is mediated by complex regulatory cascades (Osbourn and Field 2009; Osbourn 2010; Bibb 2005).

Numerous reviews summarized the methods and discussed the problems, which may arise during the procedure of activating silent clusters (e.g., Rutledge and Challis 2015; Katz and Baltz 2016; Gomez-Escribano et al. 2016; Bibb 2013; Valayil 2016). In this review, we will focus only on induction of silent clusters by manipulating gene regulation. To date, two general strategies have been employed in order to force expression of silent gene clusters: induction of secondary metabolite clusters in the native hosts (Sect. 8.6.1) or overcoming endogenous regulation by heterologous expression of the clusters (Sect. 8.6.2).

### 8.6.1 Induction of Silent Secondary Metabolite Clusters in the Native Host

One main prerequisite for the identification of novel natural products is the availability of methods for activating the expression of silent secondary metabolite clusters. Since native producers, which have the potential for the synthesis of novel

secondary metabolites, possess the appropriate resistance genes and provide the required precursors, activating gene expression directly in the native host is a preferred strategy.

### 8.6.1.1 Nontargeted Approaches to Induce Expression of Silent Clusters in the Native Producers

The synthesis of secondary metabolites is often induced by environmental stimuli (see above), but in most cases the specific signal is not yet known. Hence, culturing of microbes in diverse media, one of which hopefully providing the required stimulus, is a classic approach (often termed as OSMAC (one strain many compounds)) to activate silent gene clusters (Schiewe and Zeeck 1999; Abdelmohsen et al. 2014).

Additionally, many nontargeted approaches are described where the induction of gene expression was successful, e.g., by introduction of stress conditions (Doull et al. 1993; Yoon and Nodwell 2014; Iftime et al. 2016) or co-cultures with other microorganisms (Pettit 2009). Since production of secondary metabolites by microbes varies with composition of culture media and culture conditions (see Sects. 8.2–8.4), this approach combines two aspects of activation, the regulators and the elicitors.

The expression of biosynthetic gene clusters depends on a variety of pleiotropic transcriptional global regulators, which react on different (mostly unknown) stimuli. Regulators belonging to a particular class can be used to activate silent clusters in a heterologous host in a nontargeted manner. The manipulation of these regulators enables the production of compounds encoded by silent clusters as reported by McKenzie et al. (2010): The authors heterologously expressed AbsA1, the pleiotropic regulator of secondary metabolism from *S. coelicolor*, to activate pulvomycin production in *Streptomyces flavopersicus*, a metabolite not previously attributed to this species.

A recently developed screening platform for small molecule elicitors holds some promise for specific activation of selected gene cluster (Seyedsayamdost 2014). In this method, genetic reporter fusions monitor the activation of the silent cluster of interest, while high-throughput screening of small molecule libraries provides the candidate elicitors. Using this approach, two cryptic gene clusters in the pathogenic model organism *Burkholderia thailandensis* could be activated. Seyedsayamdost (2014) demonstrated that the majority of elicitors are antibiotics themselves, which kill *B. thailandensis* at high concentrations but act as inducers of secondary metabolism at low concentrations. One of these antibiotics, trimethoprim, served as a global activator of secondary metabolism by inducing at least five biosynthetic pathways (Seyedsayamdost 2014).

These examples demonstrate that apparently many rather unspecific induction events can be utilized to switch on expression of biosynthetic gene clusters.

### 8.6.1.2 Targeted Approaches to Induce Expression of Silent Clusters in the Native Producers

The above-described methods cannot be applied to induce the biosynthetic gene cluster of interest specifically. However, the provision of the genome sequences of the producer strains, the in silico identification of clusters by bioinformatics tools,



and the knowledge of main regulatory networks offer the possibility to target biosynthetic gene clusters individually. Manipulation of pathway-specific regulatory genes, comprising the deletion of repressors or the constitutive or controlled expression of activators, is a possible approach (Sect. 8.5.6).

In *S. ambofaciens*, the deletion of *alpW* encoding a TetR-like negative regulator resulted in the constitutive production of kinamycins (Bunet et al. 2011); in *S. coelicolor* A3(2), the synthesis of a type I polyketide (abCPK) and a yellow-pigmented secondary metabolite (yCPK) was activated after deleting a presumed pathway-specific regulatory gene (*scbR2*) that encodes a member of the  $\gamma$ -butyrolactone receptor family of proteins and which lies within the *cpk* biosynthetic gene cluster (Gottelt et al. 2010).

Besides the deletion of the negative regulators, another method to “deregulate” the expression of the biosynthetic gene is to constitutively express a particular regulatory gene activating a particular class of biosynthetic gene clusters independent of any stimuli. In *S. ambofaciens* ATCC23877, a putative regulatory gene encoding a regulator belonging to the LAL (Large ATP binding of the LuxR) family of proteins was identified. Its constitutive expression under the control of the strong *ermE*\* promoter triggered the biosynthesis of four glycosylated macrolides, named stambomycins A–D (Laureti et al. 2011).

Database searches identified genes encoding LAL regulators within numerous cryptic biosynthetic gene clusters in actinomycete genomes, suggesting that the constitutive expression of such pathway-specific activators represents a powerful approach for novel bioactive natural product discovery (Laureti et al. 2011).

Overexpression of positive regulatory genes in *Streptomyces albus* J1074 activated the biosynthesis of 6-epi-alteramides, candicidins, and antimycins (Olano et al. 2014).

Zhou et al. (2015) triggered the expression of the angucycline biosynthetic genes in *Streptomyces chattanoogensis* by overexpression of the pathway-specific activator gene under the constitutive *ermE*\* promoter.

In *Amycolatopsis japonicum*, the production of the type III glycopeptide ristomycin A (ristocetin) was activated by the heterologous expression of the balhimycin pathway-specific regulator gene *bbr*<sub>Aba</sub> (Shawky et al. 2007) from *Amycolatopsis balhimycina*, the producer of balhimycin (Spohn et al. 2014). The two related species *A. japonicum* and *A. balhimycina* each harbor a glycopeptide gene cluster including a gene encoding a regulator, *AjrR* and *Bbr*<sub>Aba</sub>, respectively. However, under standard growth conditions, *Bbr*<sub>Aba</sub> initiates the transcription of the balhimycin biosynthetic gene cluster in *A. balhimycina*, while *AjrR* does not induce the expression of the ristomycin biosynthetic genes in *A. japonicum* (Spohn et al. 2014).

Luo et al. (2015) systematically identified a panel of strong constitutive promoters, which were suitable to activate silent clusters in *Streptomyces*. Here, we describe two examples, where the insertion of the strong and constitutive *ermE*\* promoter in front of selected genes activates the production of secondary metabolites: (1) By insertion of the *ermE*\* promoter into two clusters in front of genes

encoding non-ribosomal peptide synthetase (NRPS), polyketide synthase (PKS)-NRPS hybrid and a cyclase/dehydrase, respectively, production of the blue pigment indigoidine and of two novel members of the polycyclic tetramate macrolactam family (6-epi-alteramides A and B) was activated in *S. albus* J1074 (Olano et al. 2014). (2) Insertion of the *ermE*\* promoter upstream of the lanthipeptide synthetase gene *stcL* resulted in the identification and isolation of streptocollin from *Streptomyces collinus* Tü 365, a new member of class IV lanthipeptides (Iftime et al. 2015).

The described examples demonstrate that the regulators (global or pathway specific) are a main factor in terms of expressing (silent) biosynthetic gene clusters. As the DNA-binding domains of defined regulator types are often highly similar to each other and since they often recognize equal DNA-binding motifs, it is a promising approach to compile and test a set of regulators that are able to activate antibiotic biosynthesis.

Guo et al. (2015) developed the reporter-guided mutant selection (RGMS) as a method for targeted activation of silent gene clusters. RGMS combines genome-scale random mutagenesis to generate genetic diversity and a promoter-reporter system to facilitate selection of mutants in which the transcription of the targeted gene cluster was activated. The main features of this methodology include cloning of key promoter sequences from the gene cluster of interest in front of a reporter cassette to construct the reporter plasmids, introduction of the plasmids into the target strain followed by classical mutagenesis (UV, NTG, etc.) to introduce genome-scale disturbances, and a selection system for identification of increased transcription from the target promoter in the mutant strains. The method can be used to unlock the complex regulatory circuits that often govern secondary metabolism. RGMS is a method to manipulate target gene(s) expression via genome-wide transmutations. Applying this method, two new anthraquinone aminoglycosides from *Streptomyces* sp. *PGA64* were identified (Guo et al. 2015).

## 8.6.2 Induction of Silent Secondary Metabolite Clusters by Heterologous Expression

Heterologous expression has become a major strategy due to advances in genetic manipulation and the development of suitable chassis for expression of gene clusters (Gomez-Escribano and Bibb 2012, 2014; Hwang et al. 2014; Luo et al. 2013; Ongley et al. 2013; Yamanaka et al. 2014). However, there are still many technical hurdles to overcome, which include the difficulty to clone large DNA fragments, the lack of concerted expression of the cloned genes, the limitation of precursor supply in the heterologous host, the toxicities of the end product or biosynthetic intermediates to the heterologous host, etc. Members of the order *Actinomycetales* are bacteria with high genomic G/C contents and a biased codon usage meaning that heterologous expression of biosynthetic gene clusters requires an adequate host, whose transcription and translation machinery is adapted to actinomycetal

genes. Because of the different needs at different stages of product discovery, development, and manufacturing, various expression hosts are needed (Baltz 2016). The host should be capable of expressing many structural classes of secondary metabolites with minimal interference from host secondary metabolites, it should be easily genetically manipulable, and it should be capable of producing large quantities of specific secondary metabolite structural classes (Baltz 2016). A number of *Streptomyces* strains have been developed as suitable chassis for expression of gene clusters. *S. albus* J1074 has one of the smallest streptomycetes genome (6.84 Mb), which can be considered as naturally minimized genome (Zaburanyi et al. 2014). *S. albus* J1074 has been used for the expression (Baltz 2010; Bilyk and Luzhetskyy 2014) of different types of secondary metabolites, e.g., steffimycin, an antitumor anthracycline (Gullón et al. 2006); moenomycin, a natural phosphoglycolipid antibiotic (Makitrynsky et al. 2010); the polyketide pamamycin with antibacterial activities; the polyketide antibiotic griseorhodin; mensacarcin, a potential antitumor polyketide; the antimycobacterial anthracycline antibiotic aranciamycin (Manderscheid et al. 2016); or the angucycline grecoacycline (Bilyk et al. 2016). Genome-minimized *S. avermitilis* strains (SUKA17 and SUKA22) were generated by Komatsu et al. (2010, 2013) by deleting 1.67 Mb of nonessential genes from the 9.03 Mb genome. Gomez-Escribano and Bibb (2012, 2014) constructed *S. coelicolor* strains where the active secondary metabolite gene clusters have been deleted. In addition, they possess an altered RNA polymerase and ribosome mutations, which positively affect antibiotic production in general (Hosaka et al. 2009). A number of recent publications described the successful heterologous expression of secondary metabolite gene clusters in *S. coelicolor* M1154, e.g., gene cluster encoded the synthesis of FK506 (tacrolimus), a clinically important immunosuppressant (Jones et al. 2013), of the class IV lanthipeptide streptocollin (Iftime et al. 2015) or of the polyketide antibiotics chaxamycins (Castro et al. 2015).

However, the production rates in the heterologous hosts frequently turn out to stay low, which might be due to either the missing coordination between the primary metabolism of the host and the specific demands of the introduced secondary metabolite pathway or the unbalanced general and specific regulatory events. Recently, a new strategy has been developed to directly screen for regulators in the host, which interact with introduced heterologous antibiotic biosynthetic pathways. The method combines an improved DNA affinity capturing assay with semiquantitative mass spectrometry and is suitable to identify proteins that bind to promoter regions of a given antibiotic gene cluster (Bekiesch et al. 2016). This method turned out to be a sensitive tool to identify new regulatory proteins that drive heterologous antibiotic biosynthesis.

**Acknowledgments** We gratefully acknowledge the *funding* received for our research from the DFG (SFB 766), the EU (FP7-LAPTOP), the BMBF ERA-IB (NAbUnAk), ERASysAPP (SYSTERACT), and the DZIF (TTU09.704; TTU 09.811). We also would like to thank all colleagues from the Interfaculty Institute of Microbiology and Infection Medicine for helpful discussions and all technicians and lab assistants that were involved in the different funding projects.

## References

- Abbanat D, Maiese W, Greenstein M (1999) Biosynthesis of the pyrroindomycins by *Streptomyces rugosporus* LL-42D005; characterization of nutrient requirements. *J Antibiot* 52:117–126
- Abdelmohsen UR, Cheng C, Viegelmann C et al (2014) Dereplication strategies for targeted isolation of new antityranosomal actinosporins A and B from a marine sponge associated *Actinokineospora* sp. EG49. *Mar Drugs* 12:1220–1244
- Abouzeid AZ (1972) Production of cycloheximide by *Streptomyces* sp. *Acta Microbiol Pol B* 4:83–86
- Aharonowitz Y, Demain AL (1977) Influence of inorganic phosphate and organic buffers on cephalosporin production by *Streptomyces clavuligerus*. *Arch Microbiol* 115:169–173
- Aharonowitz Y, Demain AL (1978) Carbon catabolite regulation of cephalosporin production in *Streptomyces clavuligerus*. *Antimicrob Agents Chemother* 14:159–164
- Aharonowitz Y, Friedrich CG (1980) Alanine dehydrogenase of the beta-lactam antibiotic producer *Streptomyces clavuligerus*. *Arch Microbiol* 125:137–142
- Aigle B, Pang X, Decaris B et al (2005) Involvement of AlpV, a new member of the Streptomyces antibiotic regulatory protein family, in regulation of the duplicated type II polyketide synthase alp gene cluster in Streptomyces ambofaciens. *J Bacteriol* 187:2491–2500
- Alduina R, Lo Piccolo L, D'Alia D et al (2007) Phosphate-controlled regulator for the biosynthesis of the dalbavancin precursor A40926. *J Bacteriol* 189:8120–8129
- Allenby NE, Laing E, Bucca G et al (2012) Diverse control of metabolism and other cellular processes in *Streptomyces coelicolor* by the PhoP transcription factor: genome-wide identification of in vivo targets. *Nucleic Acids Res* 40:9543–9556
- Amin R, Reuther J, Bera A et al (2012) A novel GlnR target gene, *nnar*, is involved in nitrate/nitrite assimilation in *Streptomyces coelicolor*. *Microbiology* 158:1172–1182
- Amin R, Franz-Wachtel M, Tiffert Y et al (2016) Post-translational serine/threonine phosphorylation and lysine acetylation: a novel regulatory aspect of the global nitrogen response regulator GlnR in *S. coelicolor* M145. *Front Mol Biosci* 3:38
- Amon J, Brau T, Grimrath A et al (2008) Nitrogen control in *Mycobacterium smegmatis*: nitrogen-dependent expression of ammonium transport and assimilation proteins depends on the OmpR-type regulator GlnR. *J Bacteriol* 190:7108–7116
- Angell S, Lewis CG, Buttner MJ et al (1994) Glucose repression in *Streptomyces coelicolor* A3(2): a likely regulatory role for glucose kinase. *Mol Gen Genet* 244:135–143
- Antón N, Mendes MV, Martín JF et al (2004) Identification of PimR as a positive regulator of pimaricin biosynthesis in *Streptomyces natalensis*. *J Bacteriol* 186:2567–2575
- Antón N, Santos-Aberturas J, Mendes MV et al (2007) PimM, a PAS domain positive regulator of pimaricin biosynthesis in *Streptomyces natalensis*. *Microbiology* 153:3174–3183
- Apel AK, Sola-Landa A, Rodriguez-Garcia A et al (2007) Phosphate control of *phoA*, *phoC* and *phoD* gene expression in *Streptomyces coelicolor* reveals significant differences in binding of PhoP to their promoter regions. *Microbiology* 153:3527–3537
- Arakawa K, Mochizuki S, Yamada K et al (2007)  $\gamma$ -Butyrolactone autoregulator-receptor system involved in lankacidin and lankamycin production and morphological differentiation in *Streptomyces rochei*. *Microbiology* 153:1817–1827
- Arakawa K, Tsuda N, Taniguchi A et al (2012) The butenolide signaling molecules SRB1 and SRB2 induce lankacidin and lankamycin production in *Streptomyces rochei*. *Chembiochem* 13:1447–1457
- Arias P, Fernández-Moreno M, Malpartida F (1999) Characterization of the pathway-specific positive transcriptional regulator for actinorhodin biosynthesis in *Streptomyces coelicolor* A3(2) as a DNA-binding protein. *J Bacteriol* 181:6958–6968
- Ashy MA, Abou-Zeid AA, El-Diwany AI et al (1982) Fermentative production of spiramycins. *Enzym Microb Technol* 4:20–24
- Asturias JA, Liras P, Martin JF (1990) Phosphate control of *pabS* gene transcription during candicidin biosynthesis. *Gene* 93:79–84

- Ayar-Kayali H, Tarhan I (2006) Vancomycin antibiotic production and TCA-glyoxalate pathways depending on the glucose concentration in *Amycolatopsis orientalis*. *Enzym Microb Technol* 38:727–734
- Baltz RH (2010) *Streptomyces* and *Saccharopolyspora* hosts for heterologous expression of secondary metabolite gene clusters. *J Ind Microbiol Biotechnol* 37:759–772
- Baltz RH (2016) Genetic manipulation of secondary metabolite biosynthesis for improved production in *Streptomyces* and other actinomycetes. *J Ind Microbiol Biotechnol* 43:343–370
- Bandyopadhyay SK, Majumdar SK (1974) Regulation of the formation of alkaline phosphatase during neomycin biosynthesis. *Antimicrob Agents Chemother* 5:431–434
- Basak K, Majumdar SK (1975) Mineral nutrition of *Streptomyces kanamyceticus* for kanamycin formation. *Antimicrob Agents Chemother* 8:391–395
- Bate N, Stratigopoulos G, Cundliffe E (2002) Differential roles of two SARP-encoding regulatory genes during tylosin biosynthesis. *Mol Microbiol* 43:449–458
- Bate N, Bignell DR, Cundliffe E (2006) Regulation of tylosin biosynthesis involving ‘SARP-helper’ activity. *Mol Microbiol* 62:148–156
- Behal V, Gregrova-Prusakova J, Hostalek Z (1982) Effect of inorganic phosphate and benzyl thiocyanate on the activity of anhydrotetracycline oxygenase in *Streptomyces aureofaciens*. *Folia Microbiol (Praha)* 27:102–106
- Bekiesch P, Franz-Wachtel M, Kulik A et al (2016) DNA affinity capturing identifies new regulators of the heterologously expressed novobiocin gene cluster in *Streptomyces coelicolor* M512. *Appl Microbiol Biotechnol* 100:4495–4509
- Belousova II, Lishnevskaja EB, El'gart RE et al (1970) Comparative study of synthesis of levorin and fatty acids by the mycelium of *Actinomyces levoris* Krass 26-I during its growth in native solutions of different times of fermentation. *Antibiotiki* 15:779–782
- Bermudez O, Padilla P, Huitron C et al (2006) Influence of carbon and nitrogen source on synthesis of NADP super(+)-isocitrate dehydrogenase, methylmalonyl-coenzyme A mutase, and methylmalonyl-coenzyme A decarboxylase in *Saccharopolyspora erythraea* CA340. *FEMS Microbiol Lett* 164:77–82
- Bhatnagar RK, Doull JL, Vining LC (1988) Role of the carbon source in regulating chloramphenicol production by *Streptomyces venezuelae*: studies in batch and continuous cultures. *Can J Microbiol* 34:1217–1223
- Bibb M (1996) The regulation of antibiotic production in *Streptomyces coelicolor* A3(2). *Microbiology* 142:1335–1344
- Bibb MJ (2005) Regulation of secondary metabolism in streptomycetes. *Curr Opin Microbiol* 5:208–215
- Bibb MJ (2013) Understanding and manipulating antibiotic production in actinomycetes. *Biochem Soc Trans* 41:1355–1364
- Bignell DR, Bate N, Cundliffe E (2007) Regulation of tylosin production: role of a TylP-interactive ligand. *Mol Microbiol* 63:838–847
- Bilyk B, Luzhetskyy A (2014) Unusual site-specific DNA integration into the highly active pseudo-*attB* of the *Streptomyces albus* J1074 genome. *Appl Microbiol Biotechnol* 98:5095–5104
- Bilyk O, Sekurova ON, Zotchev SB et al (2016) Cloning and heterologous expression of the grecco-cycline biosynthetic gene cluster. *PLoS One* 11:e0158682
- Borodina I, Krabben P, Nielsen J (2005) Genome-scale analysis of *Streptomyces coelicolor* A3(2) metabolism. *Genome Res* 15:820–829
- Boukhris I, Dulermo T, Chouayekh H et al (2016) Evidence for the negative regulation of phytase gene expression in *Streptomyces lividans* and *Streptomyces coelicolor*. *J Basic Microbiol* 56:59–66
- Brana AF, Demain AL (1988) Nitrogen control of antibiotic biosynthesis in actinomycetes. In: Sanchez-Esquivel S (ed) Nitrogen source control of microbial processes. CRC Press, Boca Raton, pp 99–119
- Brana AF, Wolfe S, Demain AL (1985) Ammonium repression of cephalosporin production by *Streptomyces clavuligerus*. *Can J Microbiol* 31:736–743

- Brown DD, Hitchcock MJ, Katz E (1980) Evidence for a constitutive and inducible form of kynurenine formamidase in an actinomycin-producing strain of *Streptomyces parvulus*. *Arch Biochem Biophys* 202:18–22
- Bunet R, Mendes MV, Rouhier N et al (2008) Regulation of the synthesis of the angucyclinone antibiotic alpomycin in *Streptomyces ambofaciens* by the autoregulator receptor AlpZ and its specific ligand. *J Bacteriol* 190:3293–3305
- Bunet R, Song L, Mendes MV et al (2011) Characterization and manipulation of the pathway-specific late regulator AlpW reveals *Streptomyces ambofaciens* as a new producer of kinamycins. *J Bacteriol* 193:1142–1153
- Butler MJ, Deutscher J, Postma PW et al (1999) Analysis of a *ptsH* homologue from *Streptomyces coelicolor* A3(2). *FEMS Microbiol Lett* 177:279–288
- Byrne KM, Greenstein M (1986) Nitrogen repression of gilvocarcin V production in *Streptomyces arenae* 2064. *J Antibiot (Tokyo)* 39:594–600
- Castro JF, Razmilic V, Gomez-Escribano JP et al (2015) Identification and heterologous expression of the chaxamycin biosynthesis gene cluster from *Streptomyces leeuwenhoekii*. *Appl Environ Microbiol* 81:5820–5831
- Chakraborty R, Bibb M (1997) The ppGpp synthetase gene (*relA*) of *Streptomyces coelicolor* A3(2) plays a conditional role in antibiotic production and morphological differentiation. *J Bacteriol* 179:5854–5861
- Chakraborty R, White J, Takano E et al (1996) Cloning, characterization and disruption of a (p) ppGpp synthetase gene (*relA*) of *Streptomyces coelicolor* A3(2). *Mol Microbiol* 19:357–368
- Chaudhary AK, Singh B, Maharjan S et al (2014) Switching antibiotics production on and off in actinomycetes by an IclR family transcriptional regulator from *Streptomyces peucetius* ATCC 27952. *J Microbiol Biotechnol* 24:1065–1072
- Chen GQ, Lu FP, Du LX (2008a) Natamycin production by *Streptomyces gilvosporeus* based on statistical optimization. *J Agric Food Chem* 56:5057–5061
- Chen KC, Lin YH, Wu JY et al (2003) Enhancement of clavulanic acid production in *Streptomyces clavuligerus* with ornithine feeding. *Enzym Microb Technol* 32:152–156
- Chen S, Zheng G, Zhu H et al (2016) Roles of two-component system AfsQ1/Q2 in regulating biosynthesis of the yellow-pigmented coelimycin P2 in *Streptomyces coelicolor*. *FEMS Microbiol Lett* 363(15) pii: fnw160
- Chen Y, Wendt-Pienkowski E, Shen B (2008b) Identification and utility of FdmR1 as a *Streptomyces* antibiotic regulatory protein activator for fredericamycin production in *Streptomyces griseus* ATCC 49344 and heterologous hosts. *J Bacteriol* 190:5587–5596
- Chen Y, Yin M, Horsman GP et al (2010) Manipulation of pathway regulation in *Streptomyces globosporus* for overproduction of the enediyne antitumor antibiotic C-1027. *J Antibiot (Tokyo)* 63:482–485
- Cheng YR, Hauck L, Demain AL (1995) Phosphate, ammonium, magnesium and iron nutrition of *Streptomyces hygroscopicus* with respect to rapamycin biosynthesis. *J Ind Microbiol* 14:424–427
- Cheng Z, Bown L, Tahlan K et al (2015) Regulation of coronafacoyl phytotoxin production by the PAS-LuxR family regulator CfaR in the common scab pathogen *Streptomyces scabies*. *PLoS One* 10:e0122450
- Chipeva V, Dumanova E, Todorov T et al (1991) Impact of nitrogen assimilation on regulation of antibiotic production in *Streptomyces hygroscopicus* 155. *Antibiot Khimioter* 36:5–8
- Choi D, Choi OY, Shin HJ et al (2007) Tylosin production by *Streptomyces fradiae* using raw cornmeal in airlift bioreactor. *J Microbiol Biotechnol* 17:1071–1078
- Chouayekh H, Virolle MJ (2002) The polyphosphate kinase plays a negative role in the control of antibiotic production in *Streptomyces lividans*. *Mol Microbiol* 43:919–930
- Cimburková E, Zima J, Novak J et al (1988) Nitrogen regulation of avermectins biosynthesis in *Streptomyces avermitilis* in a chemically defined medium. *J Basic Microbiol* 28:491–499
- Cortes J, Liras P, Castro JM et al (1984) Regulation of the biosynthesis of cephamycin C by *Streptomyces lactamdurans*. *Biochem Soc Trans* 12:863–864

- Cruz R, Arias ME, Soliveri J (1999) Nutritional requirements for the production of pyrazoloisoquinolinone antibiotics by *Streptomyces griseocarneus* NCIMB 40447. *Appl Microbiol Biotechnol* 53:115–119
- Cundliffe E (2006) Antibiotic production by actinomycetes: the janus faces of regulation. *J Ind Microbiol Biotechnol* 33:500–506
- D’Huys PJ, Lule I, Van Hove S et al (2011) Amino acid uptake profiling of wild type and recombinant *Streptomyces lividans* TK24 batch fermentations. *J Biotechnol* 152:132–143
- Deianova OA, Vinogradova KA, Polin AN (1988) Kinetic aspects of the relation of the growth of the producer and the biosynthesis of heliomycin depending on the carbon source in the medium. *Antibiot Khimioter* 33:253–257
- Dekleva ML, Titus JA, Strohl WR (1985) Nutrient effects on anthracycline production by *Streptomyces peucetius* in a defined medium. *Can J Microbiol* 31:287–294
- Demain AL (1989) Carbon source regulation of idiolite biosynthesis in actinomycetes. In: Shapiro S (ed) Regulation of secondary metabolism in actinomycetes. CRC Press, Boca Raton, pp 127–134
- Demain AL (1995) Emerging concepts of secondary metabolism in actinomycetes. *Actinomycetological* 9:98–117
- Demain AL, Inamine E (1970) Biochemistry and regulation of streptomycin and mannosidostreptomycinase (alpha-D-mannosidase) formation. *Bacteriol Rev* 34:1–19
- Demain AL, Aharonowitz Y, Martln J-F (1983) Metabolic control of secondary biosynthetic pathways. In: Vining LC (ed) Biochemistry and genetic regulation of commercial and important antibiotics. Addison-Wesley, London, pp 49–72
- Doull JL, Vining LC (1990) Nutritional control of actinorhodin production by *Streptomyces coelicolor* A3(2)—suppressive effects of nitrogen and phosphate. *Appl Microbiol Biotechnol* 32:449–454
- Doull JL, Ayer SW, Singh AK, Thibault P (1993) Production of a novel polyketide antibiotic, jadomycin B, by *Streptomyces venezuelae* following heat shock. *J Antibiot (Tokyo)* 46:869–871
- Du YL, Chen SF, Cheng LY et al (2009) Identification of a novel *Streptomyces chattanoogensis* L10 and enhancing its natamycin production by overexpressing positive regulator ScnRII. *J Microbiol* 47:506–513
- Dutta S, Basak B, Bhunia B et al (2014) Kinetics of rapamycin production by *Streptomyces hygrosopicus* MTCC 4003. *3 Biotech* 4:523–531
- Elibol M, Mavituna F (1998) Effect of sucrose on actinorhodin production by *Streptomyces coelicolor* A3(2). *Process Biochem* 33:307–311
- El-Naggar MY, El-Assar SA, Abdul-Gawad SM (2006) Meroparamycin production by newly isolated *Streptomyces* sp. strain MAR01: taxonomy, fermentation, purification and structural elucidation. *J Microbiol* 44:432–438
- El-Shirbiny SA, Ghaly MF, El-Ayoty YM et al (2007) Niromycin A: an antialgal substance produced by *Streptomyces endus* N40. *Res J Microbiol* 2:606–618
- El-Tayeb OM, Hussein MMM, Salama AA et al (2004) Optimization of industrial production of rifamycin B by *Amycolatopsis mediterranei*. II. The role of gene amplification and physiological factors in productivity in shake flask. *Afr J Biotechnol* 3:273–280
- Erban V, Novotná J, Běhal V et al (1983) Growth rate, sugar consumption, chlortetracycline production and anhydrotetracycline oxygenase activity in *Streptomyces aureofaciens*. *Folia Microbiol* 28:262–267
- Escalante L, Ramos I, Imriskova I et al (1999) Glucose repression of anthracycline formation in *Streptomyces peucetius* var. *caesius*. *Appl Microbiol Biotechnol* 52:572–578
- Fang J, Dorrestein PC (2014) Emerging mass spectrometry techniques for the direct analysis of microbial colonies. *Curr Opin Microbiol* 19:120–129
- Farid MA, El-Enshasy HA, El-Diwany AI et al (2000) Optimization of the cultivation medium for natamycin production by *Streptomyces natalensis*. *J Basic Microbiol* 40:157–166
- Fernández-Martínez LT, Santos-Beneit F, Martín JF (2012) Is PhoR–PhoP partner fidelity strict? PhoR is required for the activation of the *pho* regulon in *Streptomyces coelicolor*. *Mol Gen Genomics* 287:565–573

- Fink D, Falke D, Wohlleben W et al (1999) Nitrogen metabolism in *Streptomyces coelicolor* A3(2): modification of glutamine synthetase I by an adenylyltransferase. *Microbiology* 145: 2313–2322
- Fink D, Weissschuh N, Reuther J et al (2002) Two transcriptional regulators GlnR and GlnRII are involved in regulation of nitrogen metabolism in *Streptomyces coelicolor* A3(2). *Mol Microbiol* 46:331–347
- Forero A, Sanchez M, Chavez A et al (2012) Possible involvement of the *sco2127* gene product in glucose repression of actinorhodin production in *Streptomyces coelicolor*. *Can J Microbiol* 58:1195–1201
- Formica JV, Waring MJ (1983) Effect of phosphate and amino acids on echinomycin biosynthesis by *Streptomyces echinatus*. *Antimicrob Agents Chemother* 24:735–741
- Foulston L, Bibb M (2011) Feed-forward regulation of microbisporicin biosynthesis in *Microbispora corallina*. *J Bacteriol* 193:3064–3071
- Gallo G, Alduina R, Renzone G et al (2010) Differential proteomic analysis highlights metabolic strategies associated with balhimycin production in *Amycolatopsis balhimycina* chemostat cultivations. *Microb Cell Factories* 9:95
- Gallo M, Katz E (1972) Regulation of secondary metabolite biosynthesis: catabolite repression of phenoxazinone synthase and actinomycin formation by glucose. *J Bacteriol* 109:659–667
- Gao C, Hindra, Mulder D et al (2012) Crp is a global regulator of antibiotic production in *Streptomyces*. *MBio* 3(6):e00407–e00412
- Gao H, Liu M, Liu J et al (2009) Medium optimization for the production of avermectin B1a by *Streptomyces avermitilis* 14-12A using response surface methodology. *Bioresour Technol* 100:4012–4016
- Gesheva V, Ivanova V, Gesheva R (2005) Effects of nutrients on the production of AK-111-81 macrolide antibiotic by *Streptomyces hygroscopicus*. *Microbiol Res* 160:243–248
- Ghonaim SA, Khalil AM, Abouzeid AA et al (1980) Factors affecting fermentative production of magnamycin by *Streptomyces halstedii*. *Agric Waste* 2:31–36
- Giardina A, Alduina R, Gallo G et al (2014) Inorganic phosphate is a trigger factor for *Microbispora* sp. ATCC-PTA-5024 growth and NAI-107 production. *Microb Cell Factories* 13:133
- Gomez-Escribano JP, Bibb MJ (2012) Engineering *Streptomyces coelicolor* for heterologous expression of secondary metabolite gene clusters. *Microb Biotechnol* 4:207–215
- Gomez-Escribano JP, Bibb MJ (2014) Heterologous expression of natural product biosynthetic gene clusters in *Streptomyces coelicolor*: from genome mining to manipulation of biosynthetic pathways. *J Ind Microbiol Biotechnol* 41:425–431
- Gomez-Escribano JP, Martín JF, Hesketh A et al (2008) *Streptomyces clavuligerus* relA-null mutants overproduce clavulanic acid and cephamycin C: negative regulation of secondary metabolism by (p)ppGpp. *Microbiology* 154:744–755
- Gomez-Escribano JP, Alt S, Bibb MJ (2016) Next generation sequencing of actinobacteria for the discovery of novel natural products. *Mar Drugs* 14. pii: E78
- Goranovič D, Blažič M, Magdevska V et al (2012) FK506 biosynthesis is regulated by two positive regulatory elements in *Streptomyces tsukubaensis*. *BMC Microbiol* 12:238
- Görke B, Stülke J (2008) Carbon catabolite repression in bacteria: many ways to make the most out of nutrients. *Nat Rev Microbiol* 6:613–624
- Gottelt M, Kol S, Gomez-Escribano JP et al (2010) Deletion of a regulatory gene within the *cpk* gene cluster reveals novel antibacterial activity in *Streptomyces coelicolor* A3(2). *Microbiology* 156:2343–2353
- Gräfe U, Bocker H, Thrum H (1977) Regulative influence of o-aminobenzoic acid on the biosynthesis of nourseothricin in cultures of *Streptomyces noursei* JA 3890b. II. Regulation of glutamine synthetase and the role of the glutamine synthetase/glutamate synthase pathway. *Z. Allg Mikrobiol* 17:201–209
- Gullón S, Olano C, Abdelfattah MS et al (2006) Isolation, characterization, and heterologous expression of the biosynthesis gene cluster for the antitumor anthracycline steffimycin. *Appl Environ Microbiol* 72:4172–4183



- Gunnarsson N, Bruheim P, Nielsen J (2003) Production of the glycopeptide antibiotic A40926 by *Nonomuraea* sp. ATCC 39727: influence of medium composition in batch fermentation. *J Ind Microbiol Biotechnol* 30:150–156
- Guo F, Xiang S, Li L et al (2015) Targeted activation of silent natural product biosynthesis pathways by reporter-guided mutant selection. *Metab Eng* 28:134–142
- Guo J, Zhao J, Li L et al (2010) The pathway-specific regulator AveR from *Streptomyces avermitilis* positively regulates avermectin production while it negatively affects oligomycin biosynthesis. *Mol Gen Genomics* 283:123–133
- Gupte TE, Naik SR (1998) Optimisation of nutritional requirements and process control parameters for the production of HA-2-91, a new tetraene polyene antibiotic. *Hindustan Antibiot Bull* 40:5–13
- Hall MJ, Hassall CH (1970) Production of the monamycins, novel depsipeptide antibiotics. *Appl Microbiol* 19:109–112
- He JY, Vining LC, White RL et al (1995) Nutrient effects on growth and armentomycin production in cultures of *Streptomyces armentosus*. *Can J Microbiol* 41:186–193
- He X, Li R, Pan Y et al (2010) SanG, a transcriptional activator, controls nikkomycin biosynthesis through binding to the sanN-sanO intergenic region in *Streptomyces ansochromogenes*. *Microbiology* 156:828–837
- Hegetreskatis D, King R, Wolf H, Gilles ED (1992) Nutritional control of nikkomycin and juglomycin production by *Streptomyces tendae* in continuous culture. *Appl Microbiol Biotechnol* 36(4):440–445
- Hobbs G, Obanye AI, Petty J et al (1992) An integrated approach to studying regulation of production of the antibiotic methylenomycin by *Streptomyces coelicolor* A3(2). *J Bacteriol* 174:1487–1494
- Hoeksema H, Smith CG (1961) Novobiocin. *Prog Ind Microbiol* 3:91–139
- Horbal L, Rebets Y, Rabyk M et al (2012) SimReg1 is a master switch for biosynthesis and export of simocyclinone D8 and its precursors. *AMB Express* 2:1
- Horinouchi S (2002) A microbial hormone, A-factor, as a master switch for morphological differentiation and secondary metabolism in *Streptomyces griseus*. *Front Biosci* 7:2045–2057
- Horinouchi S, Beppu T (2007) Hormonal control by A-factor of morphological development and secondary metabolism in *Streptomyces*. *Proc Jpn Acad Ser B Phys Biol Sci* 83:277–295
- Hosaka T, Ohnishi-Kameyama M, Muramatsu H et al (2009) Antibacterial discovery in actinomycetes strains with mutations in RNA polymerase or ribosomal protein S12. *Nat Biotechnol* 27:462–464
- Huang D, Li S, Xia M et al (2013) Genome-scale metabolic network guided engineering of *Streptomyces tsukubaensis* for FK506 production improvement. *Microb Cell Factories* 12:1–18
- Huang J-W, Shih H-D, Huang H-C et al (2007) Effects of nutrients on production of fungichromin by *Streptomyces padanus* PMS-702 and efficacy of control of *Phytophthora infestans*. *Can J Plant Pathol* 29:261–267
- Hwang KS, Kim HU, Charusanti P et al (2014) Systems biology and biotechnology of *Streptomyces* species for the production of secondary metabolites. *Biotechnol Adv* 2:255–268
- Iftime D, Jasyk M, Kulik A et al (2015) Streptocollin, a type IV lanthipeptide produced by *Streptomyces collinus* Tü 365. *Chembiochem* 16:2615–2623
- Iftime D, Kulik A, Härtner T et al (2016) Identification and activation of novel biosynthetic gene clusters by genome mining in the kirromycin producer *Streptomyces collinus* Tü 365. *J Ind Microbiol Biotechnol* 43:277–291
- Ikeda H, Kotaki H, Tanaka H et al (1988) Involvement of glucose catabolism in avermectin production by *Streptomyces avermitilis*. *Antimicrob Agents Chemother* 32:282–284
- Im J-H, Lee M-J, Lee SY et al (2009) A putative secreted solute binding protein, SCO6569 is a possible AfsR2-dependent down-regulator of actinorhodin biosynthesis in *Streptomyces coelicolor*. *Process Biochem* 44:373–377
- Inoue OO, Netto WS, Padilla G et al (2007) Carbon catabolite repression of retamycin production by *Streptomyces olindensis* ICB20. *Braz J Microbiol* 38:58–61
- Jakeman DL, Graham CL, Young W et al (2006) Culture conditions improving the production of jadomycin B. *J Ind Microbiol Biotechnol* 33:767–772

- Jenkins VA, Barton GR, Robertson BD et al (2013) Genome wide analysis of the complete GlnR nitrogen-response regulon in *Mycobacterium smegmatis*. *BMC Genomics* 14:301
- Jiang S, Huang WY (2004) Improvement of fermentation conditions for azalomycin B produced by *Streptomyces hygroscopicus* NND-52-C. *Chin J. Bioprocess Eng* 2:53–57
- Jiao RS, Chen YM, Wu MG et al (1979) Studies on the metabolic regulation of biosynthesis of rifamycin by *Nocardia (Amycolatopsis) mediterranei* I. The stimulative effect of nitrate on biosynthesis of rifamycin SV by *Nocardia mediterranei*. *Acta Phytophysiol Sin* 5:395–402
- Jin Z, Jiao R (1997) Stimulative effects of nitrate and magnesium salts on biosynthesis of lincomycin by *Streptomyces lincolnensis*. *Chin Biochem J* 13:709–715
- Jones AC, Gust B, Kulik A et al (2013) Phage p1-derived artificial chromosomes facilitate heterologous expression of the FK506 gene cluster. *PLoS One* 8:e69319
- Jonsbu E, Ellingsen TE, Nielsen J (2000) Effects of nitrogen sources on cell growth and production of nystatin by *Streptomyces noursei*. *J Antibiot (Tokyo)* 53:1354–1362
- Joshi MV, Bignell DR, Johnson EG et al (2007) The AraC/XylS regulator TxtR modulates thaxtomin biosynthesis and virulence in *Streptomyces scabies*. *Mol Microbiol* 66:633–642
- Katz E, Pienta P, Sivak A (1958) The role of nutrition in the synthesis of actinomycin. *Appl Microbiol* 6:236–241
- Katz L, Baltz RH (2016) Natural product discovery: past, present, and future. *J Ind Microbiol Biotechnol* 43:155–176
- Khaoua S, Lebrihi A, Germain P et al (1991) Cephamycin C biosynthesis in *Streptomyces cattleya*: nitrogen source regulation. *Appl Microbiol Biotechnol* 35:253–257
- Khokhlov AS, Tovarova II, Borisova LN et al (1967) The A-factor, responsible for streptomycin biosynthesis by mutant strains of *Actinomyces streptomycin*. *Dokl Akad Nauk SSSR* 177:232–235
- Kim E-S, Hong H-J, Choi C-Y et al (2001) Modulation of actinorhodin biosynthesis in *Streptomyces lividans* by glucose repression of *afsR2* gene transcription. *J Bacteriol* 183:2198–2203
- Kim SH, Kim BG (2016) NAD(+)-specific glutamate dehydrogenase (EC.1.4.1.2) in *Streptomyces coelicolor*; in vivo characterization and the implication for nutrient-dependent secondary metabolism. *Appl Microbiol Biotechnol* 100:5527–5536
- Kinoshita H, Ipposhi H, Okamoto S et al (1997) Butyrolactone autoregulator receptor protein (BarA) as a transcriptional regulator in *Streptomyces virginiae*. *J Bacteriol* 179:6986–6993
- Kirk S, Avignone-Rossa CA, Bushell ME (2000) Growth limiting substrate affects antibiotic production and associated metabolic fluxes in *Streptomyces clavuligerus*. *Biotechnol Lett* 22:1803–1809
- Kitani S, Kinoshita H, Nihira T et al (1999) *In vitro* analysis of the butyrolactone autoregulator receptor protein (FarA) of *Streptomyces lavendulae* FRI-5 reveals that FarA acts as a DNA-binding transcriptional regulator that controls its own synthesis. *J Bacteriol* 181:5081–5084
- Kitani S, Miyamoto KT, Takamatsu S et al (2011) Avenolide, a *Streptomyces* hormone controlling antibiotic production in *Streptomyces avermitilis*. *PNAS* 108:16410–16415
- Kojima I, Cheng YR, Mohan V et al (1995) Carbon source nutrition of rapamycin biosynthesis in *Streptomyces hygroscopicus*. *J Ind Microbiol* 14:436–439
- Komatsu M, Uchiyama T, Omura S et al (2010) Genome-minimized *Streptomyces* host for the heterologous expression of secondary metabolism. *PNAS* 107:2646–2651
- Komatsu M, Komatsu K, Koizumi H et al (2013) Engineered *Streptomyces avermitilis* host for heterologous expression of biosynthetic gene cluster for secondary metabolites. *ACS Synth Biol* 2:384–396
- Kominek LA (1972) Biosynthesis of novobiocin by *Streptomyces niveus*. *Antimicrob Agents Chemother* 1:123–134
- Kormanec J, Novakova R, Mingyar E et al (2014) Intriguing properties of the angucycline antibiotic auricin and complex regulation of its biosynthesis. *Appl Microbiol Biotechnol* 98:45–60
- Kudo K, Suto T, Yoshida Y et al (1993) Improved production of a chromophore component of antitumor antibiotic neocarzinostatin (NCS) by addition of threonine in a chemically defined medium. *J Ferment Bioeng* 75:223–225
- Kurobane I, Dale PL, Vining LC (1987) Characterization of new viridomycins and requirements for production in cultures of *Streptomyces griseus*. *J Antibiot (Tokyo)* 40:1131–1139

- Kuščer E, Coates N, Challis I et al (2007) Roles of rapH and rapG in positive regulation of rapamycin biosynthesis in *Streptomyces hygroscopicus*. *J Bacteriol* 189:4756–4763
- Kwakman JH, Postma PW (1994) Glucose kinase has a regulatory role in carbon catabolite repression in *Streptomyces coelicolor*. *J Bacteriol* 176:2694–2698
- Laureti L, Song L, Huang S et al (2011) Identification of a bioactive 51-membered macrolide complex by activation of a silent polyketide synthase in *Streptomyces ambofaciens*. *PNAS* 108:6258–6263
- Le TB, Fiedler HP, den Hengst CD et al (2009) Coupling of the biosynthesis and export of the DNA gyrase inhibitor simocyclinone in *Streptomyces antibioticus*. *Mol Microbiol* 72:1462–1474
- Lebrihi A, Lamsaif D, Lefebvre G et al (1992) Effect of ammonium ions on spiramycin biosynthesis in *Streptomyces ambofaciens*. *Appl Microbiol Biotechnol* 37:382–387
- Lee HN, Kim ES (2008) Actinorhodin biosynthesis is negatively regulated by a putative AfsR2-dependent secreted solute binding protein, SCO6569 in *Streptomyces coelicolor*. *J Biotechnol* 136:S69–S69
- Lee HN, Im JH, Lee MJ et al (2009) A putative secreted solute binding protein, SCO6569 is a possible AfsR2-dependent down-regulator of actinorhodin biosynthesis in *Streptomyces coelicolor*. *Process Biochem* 44:373–377
- Lee MS, Kojima I, Demain AL (1997) Effect of nitrogen source on biosynthesis of rapamycin by *Streptomyces hygroscopicus*. *J Ind Microbiol Biotechnol* 19:83–86
- Lee SH (1997) Ammonium ion affecting tylosin production by *Streptomyces fradiae* NRRL 2702 in continuous culture. *Lett Appl Microbiol* 25:349–352
- Lee SH, Lee KJ (1993) Aspartate aminotransferase and tylosin biosynthesis in *Streptomyces fradiae*. *Appl Environ Microbiol* 59:822–827
- Lee Y, Lee M, Choi Y et al (2014) Optimization of cultivation medium and fermentation parameters for lincomycin production by *Streptomyces lincolnensis*. *Biotechnol Bioprocess Eng* 19:1014
- Li Q, Wang L, Xie Y et al (2013) SsaA, a member of a novel class of transcriptional regulators, controls sansanmycin production in *Streptomyces* sp. strain SS through a feedback mechanism. *J Bacteriol* 195:2232–2243
- Li R, Xie Z, Tian Y et al (2009) polR, a pathway-specific transcriptional regulatory gene, positively controls polyoxin biosynthesis in *Streptomyces cacaoi* subsp. *asoensis*. *Microbiology* 155:1819–1831
- Liao CH et al (2015) Nitrogen regulator GlnR controls uptake and utilization of non-phosphotransferasesystem carbon sources in actinomycetes. *Proc Natl Acad Sci U S A* 112(51):15630–15635
- Lilley G, Clark AE, Lawrence GC (1981) Control of the production of cephamycin-C and thienamycin by *Streptomyces cattleya* Nrrl 8057. *J Chem Technol Biotechnol* 31:127–134
- Liras P, Villanueva JR, Martin JF (1977) Sequential expression of macromolecule biosynthesis and candidin formation in *Streptomyces griseus*. *J Gen Microbiol* 102:269–277
- Lounes A, Lebrihi A, Benslimane C et al (1995) Regulation of valine catabolism by ammonium in *Streptomyces ambofaciens*, producer of spiramycin. *Can J Microbiol* 41:800–808
- Lounes A, Lebrihi A, Benslimane C et al (1996a) Effect of nitrogen carbon ratio on the specific production rate of spiramycin by *Streptomyces ambofaciens*. *Process Biochem* 31:13–20
- Lounes A, Lebrihi A, Benslimane C et al (1996b) Regulation of spiramycin synthesis in *Streptomyces ambofaciens*: effects of glucose and inorganic phosphate. *Appl Microbiol Biotechnol* 45:204–211
- Luo Y, Huang H, Liang J et al (2013) Activation and characterization of a cryptic polycyclic tetramate macrolactam biosynthetic gene cluster. *Nat Commun* 4:2894
- Luo Y, Zhang L, Barton KW et al (2015) Systematic identification of a panel of strong constitutive promoters from *Streptomyces albus*. *ACS Synth Biol* 4:1001–1010
- Madry N, Pape H (1982) Formation of secondary metabolism enzymes in the tylosin producer *Streptomyces* T 59-235. *Arch Microbiol* 131:170–173
- Maiti SK, Singh KP, Lantz AE et al (2010) Substrate uptake, phosphorus repression, and effect of seed culture on glycopeptide antibiotic production: process model development and experimental validation. *Biotechnol Bioeng* 105:109–120
- Majumdar MK, Majumdar SK (1965) Effects of minerals on neomycin production by *Streptomyces fradiae*. *Appl Microbiol* 13:190–193

- Majumdar MK, Majumdar SK (1971) Synthesis of neomycin by washed mycelium of *Streptomyces fradiae* and some physiological considerations. *Folia Microbiol (Praha)* 16:285–292
- Makitrynsky R, Rebets Y, Ostash B et al (2010) Genetic factors that influence moenomycin production in streptomycetes. *J Ind Microbiol Biotechnol* 37:559–566
- Malm S, Tiffert Y, Micklinghoff J et al (2009) The roles of the nitrate reductase NarGHJI, the nitrite reductase NirBD and the response regulator GlnR in nitrate assimilation of *Mycobacterium tuberculosis*. *Microbiology* 155:1332–1339
- Manderscheid N, Bilyk B, Busche T et al (2016) An influence of the copy number of biosynthetic gene clusters on the production level of antibiotics in a heterologous host. *J Biotechnol* 232:110–117
- Martin JF (2004) Phosphate control of the biosynthesis of antibiotics and other secondary metabolites is mediated by the PhoR-PhoP system: an unfinished story. *J Bacteriol* 186:5197–5201
- Martin JF, Demain AL (1980) Control of antibiotic biosynthesis. *Microbiol Rev* 44:230–251
- Martin JF, Liras P (2010) Engineering of regulatory cascades and networks controlling antibiotic biosynthesis in *Streptomyces*. *Curr Opin Microbiol* 13:263–273
- Martin JF, Sola-Landa A, Santos-Beneit F et al (2011) Cross-talk of global nutritional regulators in the control of primary and secondary metabolism in *Streptomyces*. *Microb Biotechnol* 4:165–174
- Martinez-Castro M, Salehi-Najafabadi Z, Romero F et al (2013) Taxonomy and chemically semi-defined media for the analysis of the tacrolimus producer '*Streptomyces tsukubaensis*'. *Appl Microbiol Biotechnol* 97:2139–2152
- Mast Y, Wohlleben W (2014) Streptogramins—two are better than one! *Int J Med Microbiol* 304:44–50
- Mast Y, Guezguez J, Handel F et al (2015) A complex signaling cascade governs pristinamycin biosynthesis in *Streptomyces pristinaespiralis*. *Appl Environ Microbiol* 81:6621–6636
- Masuma R, Tanaka Y, Omura S (1983) Ammonium ion-depressed fermentation of tylosin by the use of a natural zeolite and its significance in the study of biosynthetic regulation of the antibiotic. *J Ferment Technol* 61:607–614
- Masuma R, Tanaka Y, Tanaka H et al (1986) Production of nanaomycin and other antibiotics by phosphate-depressed fermentation using phosphate-trapping agents. *J Antibiot (Tokyo)* 39:1557–1564
- Matsuno K, Yamada Y, Lee CK et al (2004) Identification by gene deletion analysis of *barB* as a negative regulator controlling an early process of virginiamycin biosynthesis in *Streptomyces virginiae*. *Arch Microbiol* 181:52–59
- McDowall KJ, Thamchaipenet A, Hunter IS (1999) Phosphate control of oxytetracycline production by *Streptomyces rimosus* is at the level of transcription from promoters overlapped by tandem repeats similar to those of the DNA-binding sites of the OmpR family. *J Bacteriol* 181:3025–3032
- McIntyre JJ, Bull AT, Bunch AW (1996) Vancomycin production in batch and continuous culture. *Biotechnol Bioeng* 49:412–420
- McKenzie NL, Thaker M, Koteva K et al (2010) Induction of antimicrobial activities in heterologous streptomycetes using alleles of the *Streptomyces coelicolor* gene *absA1*. *J Antibiot (Tokyo)* 63:177–182
- Mendes MV, Tunca S, Anton N et al (2007) The two-component *phoR-phoP* system of *Streptomyces natalensis*: inactivation or deletion of *phoP* reduces the negative phosphate regulation of pimaricin biosynthesis. *Metab Eng* 9:217–227
- Miller AL, Walker JB (1970) Accumulation of streptomycin-phosphate in cultures of streptomycin producers grown on a high-phosphate medium. *J Bacteriol* 104:8–12
- Müller PJ, Haubold G, Menner M et al (1984) Effect of phosphate on the biosynthesis of nourseothricin by *Streptomyces noursei* Ja-3890b. *Z Allg Mikrobiol* 24:555–564
- Muramatsu Y, Arai M, Sakaida Y et al (2006) Studies on novel bacterial translocase I inhibitors, A-500359s. V. Enhanced production of capuramycin and A-500359 A in *Streptomyces griseus* SANK 60196. *J Antibiot (Tokyo)* 59:601–606
- Narva KE, Feitelson JS (1990) Nucleotide sequence and transcriptional analysis of the *redD* locus of *Streptomyces coelicolor* A3(2). *J Bacteriol* 172:326–333

- Niesel K, Battke F, Herbig A et al (2010) The dynamic architecture of the metabolic switch in *Streptomyces coelicolor*. *BMC Genomics* 11:1–9
- Niu G, Chater KF, Tian Y et al (2016) Specialised metabolites regulating antibiotic biosynthesis in *Streptomyces* spp. *FEMS Microbiol Rev* 40:554–573
- Nodwell JR (2014) Are you talking to me? A possible role for  $\gamma$ -butyrolactones in interspecies signalling. *Mol Microbiol* 94:483–485
- Nothaft H, Dresel D, Willimek A et al (2003) The phosphotransferase system of *Streptomyces coelicolor* is biased for N-acetylglucosamine metabolism. *J Bacteriol* 185:7019–7023
- Novák J, Kopecký J, Vaněk Z (1997) Nitrogen source regulates expression of alanine dehydrogenase isoenzymes in *Streptomyces avermitilis* in a chemically defined medium. *Can J Microbiol* 43:189–193
- Novakova R, Homerova D, Feckova L et al (2005) Characterization of a regulatory gene essential for the production of the angucycline-like polyketide antibiotic auricin in *Streptomyces aureofaciens* CCM 3239. *Microbiology* 151:2693–2706
- Novakova R, Kutas P, Feckova L et al (2010) The role of the TetR-family transcriptional regulator AurIR in negative regulation of the auricin gene cluster in *Streptomyces aureofaciens* CCM 3239. *Microbiology* 156:2374–2383
- Novakova R, Rehakova A, Kutas P et al (2011) The role of two SARP family transcriptional regulators in regulation of the auricin gene cluster in *Streptomyces aureofaciens* CCM 3239. *Microbiology* 157:1629–1639
- Obregon AM, Escalante L, Gonzalez R et al (1994) Physiological studies on gentamicin phosphate repression of antibiotic formation. *J Antibiot (Tokyo)* 47:1442–1446
- Ochi K (1986) Occurrence of the stringent response in *Streptomyces* sp. and its significance for the initiation of morphological and physiological differentiation. *J Gen Microbiol* 132:2621–2631
- Ohnishi Y, Yamazaki H, Kato JY et al (2005) AdpA, a central transcriptional regulator in the A-factor regulatory cascade that leads to morphological development and secondary metabolism in *Streptomyces griseus*. *Biosci Biotechnol Biochem* 69:431–439
- Olano C, García I, González A et al (2014) Activation and identification of five clusters for secondary metabolites in *Streptomyces albus* J1074. *Microb Biotechnol* 7:242–256
- Omura S, Tanaka Y (1986) Biosynthesis of tylosin and its regulation by ammonium and phosphate. In: Kleinkauf H, Döhren HV, Dormauer H, Nesmann G (eds) Regulation of secondary metabolite formation. VCH Publishers, Berlin, pp 306–332
- Omura S, Tanaka Y, Kitao C et al (1980) Stimulation of leucomycin production by magnesium phosphate and its relevance to nitrogen catabolite regulation. *Antimicrob Agents Chemother* 18:691–695
- Omura S, Taki A, Matsuda K et al (1984) Ammonium ions suppress the amino acid metabolism involved in the biosynthesis of protylonolide in a mutant of *Streptomyces fradiae*. *J Antibiot (Tokyo)* 37:1362–1369
- Onaka H, Horinouchi S (1997) DNA-binding activity of the A-factor receptor protein and its recognition DNA sequences. *Mol Microbiol* 24:991–1000
- Ongley SE, Bian X, Neilan BA et al (2013) Recent advances in the heterologous expression of microbial natural product biosynthetic pathways. *Nat Prod Rep* 30:1121–1138
- Osborn A (2010) Secondary metabolic gene clusters: evolutionary toolkits for chemical innovation. *Trends Genet* 26:449–457
- Osborn AE, Field B (2009) Operons. *Cell Mol Life Sci* 66:3755–3775
- Ostash B, Rebets Y, Myronovskyy M et al (2011) Identification and characterization of the *Streptomyces globisporus* 1912 regulatory gene *IndYR* that affects sporulation and antibiotic production. *Microbiology* 157:1240–1249
- Pandey A, Shukla A, Majumdar SK (2005) Utilization of carbon and nitrogen sources by *Streptomyces kanamyceticus* M27 for the production of an antibacterial antibiotic. *Afr J Biotechnol* 4:909–910
- Parche S, Schmid R, Titgemeyer F (1999) The phosphotransferase system (PTS) of *Streptomyces coelicolor* identification and biochemical analysis of a histidine phosphocarrier protein HPr encoded by the gene *ptsH*. *Eur J Biochem* 265:308–317

- Park SS, Yang YH, Song E et al (2009) Mass spectrometric screening of transcriptional regulators involved in antibiotic biosynthesis in *Streptomyces coelicolor* A3(2). *J Ind Microbiol Biotechnol* 36:1073–1083
- Pass L, Raczynska-Bojanowska K (1968) On the inhibition mechanisms of viomycin synthesis by inorganic phosphate. *Acta Biochim Pol* 15:355–367
- Pérez-Redondo R, Rodríguez-García A, Martín JF et al (1998) The *clnR* gene of *Streptomyces clavuligerus*, encoding a LysR-type regulatory protein controlling clavulanic acid biosynthesis, is linked to the clavulanate-9-aldehyde reductase (*car*) gene. *Gene* 211:311–321
- Perez-Redondo R, Rodriguez-Garcia A, Botas A et al (2012) ArgR of *Streptomyces coelicolor* is a versatile regulator. *PLoS One* 7:e32697
- Pettit RK (2009) Mixed fermentation for natural product drug discovery. *Appl Microbiol Biotechnol* 83:19–25
- Piepersberg W, Distler J (1997) Aminoglycosides and sugar components in other secondary metabolites. In: Rehm H-J, Reed G (eds) *Biotechnology. Products of secondary metabolism* (Kleinkauf H, von Döhren H, eds), 2nd edn, vol 7. VCH, Weinheim, pp 397–488
- Polkade AV, Mantri SS, Patwekar UJ et al (2016) Quorum sensing: an under-explored phenomenon in the phylum actinobacteria. *Front Microbiol* 7:131
- Poole K (2012) Bacterial stress responses as determinants of antimicrobial resistance. *J Antimicrob Chemother* 67:2069–2089
- Pullan ST, Chandra G, Bibb MJ et al (2011) Genome-wide analysis of the role of GlnR in *Streptomyces venezuelae* provides new insights into global nitrogen regulation in actinomycetes. *BMC Genomics* 12:175
- Pulsawat N, Kitani S, Fukushima E et al (2009) Hierarchical control of virginiamycin production in *Streptomyces virginiae* by three pathway-specific regulators: VmsS, VmsT, and VmsR. *Microbiology* 155:1250–1259
- Qu S, Kang Q, Wu H et al (2015) Positive and negative regulation of GlnR in validamycin A biosynthesis by binding to different loci in promoter region. *Appl Microbiol Biotechnol* 99:4771–4783
- Ramos JL, Martinez-Bueno M, Molina-Henares AJ et al (2005) The TetR family of transcriptional repressors. *Microbiol Mol Biol Rev* 69:326–356
- Raytapadar S, Paul AK (2001) Production of an antifungal antibiotic by *Streptomyces aburaviensis* 1DA-28. *Microbiol Res* 155:315–323
- Rebets Y, Dutko L, Ostash B et al (2008) Function of *lanI* in regulation of landomycin A biosynthesis in *Streptomyces cyanogenus* S136 and cross-complementation studies with *Streptomyces* antibiotic regulatory proteins encoding genes. *Arch Microbiol* 189:111–120
- Reeve LM, Baumberg S (1998) Physiological controls of erythromycin production by *Saccharopolyspora erythraea* are exerted at least in part at the level of transcription. *Biotechnol Lett* 20:585–589
- Reuther J, Wohlleben W (2007) Nitrogen metabolism in *Streptomyces coelicolor*: transcriptional and post-translational regulation. *J Mol Microb Biotechnol* 12:139–146
- Rigali S, Nothhaft H, Noens EE et al (2006) The sugar phosphotransferase system of *Streptomyces coelicolor* is regulated by the GntR-family regulator DasR and links N-acetylglucosamine metabolism to the control of development. *Mol Microbiol* 61:1237–1251
- Rigali S, Titgemeyer F, Barends S et al (2008) Feast or famine: the global regulator DasR links nutrient stress to antibiotic production by *Streptomyces*. *EMBO Rep* 9:670–675
- Rodríguez M, Núñez LE, Braña AF et al (2008) Identification of transcriptional activators for thienamycin and cephamycin C biosynthetic genes within the thienamycin gene cluster from *Streptomyces cattleya*. *Mol Microbiol* 69:633–645
- Rodríguez-García A, Sola-Landa A, Apel K et al (2009) Phosphate control over nitrogen metabolism in *Streptomyces coelicolor*: direct and indirect negative control of *glnR*, *glnA*, *glnIII* and *amtB* expression by the response regulator PhoP. *Nucleic Acids Res* 37:3230–3242
- Romero J, Liras P, Martin JF (1984) Dissociation of cephamycin and clavulanic acid biosynthesis in *Streptomyces clavuligerus*. *Appl Microbiol Biotechnol* 20:318–325

- Romero-Rodríguez A, Robledo-Casados I, Sánchez S (2015) An overview on transcriptional regulators in *Streptomyces*. *Biochim Biophys Acta* 1849:1017–1039
- Romero-Rodríguez A, Rocha D, Ruiz-Villafan B et al (2016) Transcriptomic analysis of a classical model of carbon catabolite regulation in *Streptomyces coelicolor*. *BMC Microbiol* 16:77
- Roszkowski J, Rafalski A, Raczynska-Bojanowska K (1969) Alanine and alanine dehydrogenase in *Streptomyces erythreus*. *Acta Microbiol Pol B* 1:59–68
- Rutledge PJ, Challis GL (2015) Discovery of microbial natural products by activation of silent biosynthetic gene clusters. *Nat Rev Microbiol* 13:509–523
- Ryu YG, Kim ES, Kim DW et al (2007) Differential stringent responses of *Streptomyces coelicolor* M600 to starvation of specific nutrients. *J Microbiol Biotechnol* 17:305–312
- Sanchez S, Demain AL (2002) Metabolic regulation of fermentation processes. *Enzym Microb Technol* 31:895–906
- Sanchez S, Chavez A, Forero A et al (2010) Carbon source regulation of antibiotic production. *J Antibiot* 63:442–459
- Santamarta I, Rodriguez-Garcia A, Pérez-Redondo R et al (2002) CcaR is an autoregulatory protein that binds to the *ccaR* and *cefD-cmcl* promoters of the cephamycin C-clavulanic acid cluster in *Streptomyces clavuligerus*. *J Bacteriol* 184:3106–3113
- Santos-Beneit F (2015) The Pho regulon: a huge regulatory network in bacteria. *Front Microbiol* 6:402
- Santos-Beneit F, Rodriguez-Garcia A, Apel AK et al (2009a) Phosphate and carbon source regulation of two PhoP-dependent glycerophosphodiester phosphodiesterase genes of *Streptomyces coelicolor*. *Microbiology* 155:1800–1811
- Santos-Beneit F, Rodriguez-Garcia A, Sola-Landa A et al (2009b) Cross-talk between two global regulators in *Streptomyces*: PhoP and AfsR interact in the control of *afsS*, *pstS* and *phoRP* transcription. *Mol Microbiol* 72:53–68
- Santos-Beneit F, Barriuso-Iglesias M, Fernandez-Martinez LT et al (2011a) The RNA polymerase omega factor RpoZ is regulated by PhoP and has an important role in antibiotic biosynthesis and morphological differentiation in *Streptomyces coelicolor*. *Appl Environ Microbiol* 77:7586–7594
- Santos-Beneit F, Rodriguez-Garcia A, Martin JF (2011b) Complex transcriptional control of the antibiotic regulator *afsS* in *Streptomyces*: PhoP and AfsR are overlapping, competitive activators. *J Bacteriol* 193:2242–2251
- Santos-Beneit F, Rodriguez-Garcia A, Martin JF (2012) Overlapping binding of PhoP and AfsR to the promoter region of *glnR* in *Streptomyces coelicolor*. *Microbiol Res* 167:532–535
- Satoh A, Ogawa H, Satomura Y (1975) Role and regulation mechanism of kanamycin acetyltransferase in kanamycin biosynthesis. *Agric Biol Chem* 39:2331–2336
- Schiewe HJ, Zeeck A (1999) Cineromycins, gamma-butyrolactones and ansamycins by analysis of the secondary metabolite pattern created by a single strain of *Streptomyces*. *J Antibiot (Tokyo)* 52:635–642
- Schimana J, Walker M, Zeeck A et al (2001) Simocyclinones: diversity of metabolites is dependent on fermentation conditions. *J Ind Microbiol Biotechnol* 27:144–148
- Seyedsayamdost MR (2014) High-throughput platform for the discovery of elicitors of silent bacterial gene clusters. *PNAS* 111:7266–7271
- Shao Z, Wei Z, Wang Y et al (2015a) “Nitrate stimulating effect” in *Amycolatopsis mediterranei*—from discovery to mechanistic studies. *Chin J Biotechnol* 31:845–856
- Shao ZH, Ren SX, Liu XQ et al (2015b) A preliminary study of the mechanism of nitrate-stimulated remarkable increase of rifamycin production in *Amycolatopsis mediterranei* U32 by RNA-seq. *Microb Cell Factories* 14:75
- Shapiro S, Vining LC (1983) Nitrogen metabolism and chloramphenicol production in *Streptomyces venezuelae*. *Can J Microbiol* 29:1706–1714
- Shapiro S, Vining LC (1984) Suppression of nitrate utilization by ammonium and its relationship to chloramphenicol production in *Streptomyces venezuelae*. *Can J Microbiol* 30:798–804
- Shawky RM, Puk O, Wietzorrek A et al (2007) The border sequence of the balhimycin biosynthesis gene cluster from *Amycolatopsis balhimycina* contains *bbR*, encoding a StrR-like pathway-specific regulator. *J Mol Microbiol Biotechnol* 13:76–88

- Smanski MJ, Peterson RM, Rajski SR et al (2009) Engineered *Streptomyces platensis* strains that overproduce antibiotics platensimycin and platencin. *Antimicrob Agents Chemother* 53:1299–1304
- Sola-Landa A, Moura RS, Martin JF (2003) The two-component PhoR-PhoP system controls both primary metabolism and secondary metabolite biosynthesis in *Streptomyces lividans*. *PNAS* 100:6133–6138
- Sola-Landa A, Rodriguez-Garcia A, Franco-Dominguez E et al (2005) Binding of PhoP to promoters of phosphate-regulated genes in *Streptomyces coelicolor*: identification of PHO boxes. *Mol Microbiol* 56:1373–1385
- Sola-Landa A, Rodriguez-Garci A, Apel AK et al (2008) Target genes and structure of the direct repeats in the DNA-binding sequences of the response regulator PhoP in *Streptomyces coelicolor*. *Nucleic Acids Res* 36:1358–1368
- Sola-Landa A, Rodriguez-Garcia A, Amin R et al (2013) Competition between the GlnR and PhoP regulators for the *glnA* and *amtB* promoters in *Streptomyces coelicolor*. *Nucleic Acids Res* 41:1767–1782
- Spohn M, Kirchner N, Kulik A et al (2014) Overproduction of Ristomycin A by activation of a silent gene cluster in *Amycolatopsis japonicum* MG417-CF17. *Antimicrob Agents Chemother* 58:6185–6196
- Steinkämper A, Schmid J, Schwartz D et al (2015) Development of cultivation strategies for friulimycin production in *Actinoplanes friuliensis*. *J Biotechnol* 195:52–59
- Stocks SM, Thomas CR (2001) Viability, strength, and fragmentation of *Saccharopolyspora erythraea* in submerged fermentation. *Biotechnol Bioeng* 75:702–709
- Strauch E, Takano E, Baylis HA et al (1991) The stringent response in *Streptomyces coelicolor* A3(2). *Mol Microbiol* 5:289–298
- Sujatha P, Bapi Raju KV, Ramana T (2005) Studies on a new marine *Streptomyces* BT-408 producing polyketide antibiotic SBR-22 effective against methicillin resistant *Staphylococcus aureus*. *Microbiol Res* 160:119–126
- Suzuki T, Mochizuki S, Yamamoto S et al (2010) Regulation of lankamycin biosynthesis in *Streptomyces rochei* by two SARP genes, *srrY* and *srrZ*. *Biosci Biotechnol Biochem* 74: 819–827
- Swiatek MA, Gubbens J, Bucca G et al (2013) The ROK family regulator Rok7B7 pleiotropically affects xylose utilization, carbon catabolite repression, and antibiotic production in *Streptomyces coelicolor*. *J Bacteriol* 195:1236–1248
- Tahlan K, Yu Z, Xu Y et al (2008) Ligand recognition by ActR, a TetR-like regulator of actinorhodin export. *J Mol Biol* 383:753–761
- Takano E, Nihira T, Hara Y et al (2000) Purification and structural determination of SCB1, a gamma-butyrolactone that elicits antibiotic production in *Streptomyces coelicolor* A3(2). *J Biol Chem* 275:11010–11016
- Tanaka A, Takano Y, Ohnishi Y et al (2007) AfsR recruits RNA polymerase to the *afsS* promoter: a model for transcriptional activation by SARPs. *J Mol Biol* 369:322–333
- Tanaka Y, Masuma R, Omura S (1984) Control of ammonium ion level for efficient nanaomycin production. *J Antibiot (Tokyo)* 37:1370–1375
- Tenconi E, Jourdan S, Motte P et al (2012) Extracellular sugar phosphates are assimilated by *Streptomyces* in a PhoP-dependent manner. *Antonie Van Leeuwenhoek* 102:425–433
- Tereshin IM (1976) Polyene antibiotics—present and future, E R Squibb lectures on chemistry of microbial products. University of Tokyo Press, Tokyo, pp 136–142
- Thakur D, Bora TC, Bordoloi GN et al (2009) Influence of nutrition and culturing conditions for optimum growth and antimicrobial metabolite production by *Streptomyces* sp. 201. *J Mycol Med* 19:161–167
- Theobald U, Schimana J, Fiedler HP (2000) Microbial growth and production kinetics of *Streptomyces antibioticus* Tü 6040. *Antonie Van Leeuwenhoek* 78:307–313
- Thomas L, Hodgson DA, Wentzel A et al (2012) Metabolic switches and adaptations deduced from the proteomes of *Streptomyces coelicolor* wild type and *phoP* mutant grown in batch culture. *Mol Cell Proteomics* 11:M111 013797



- Tiffert Y, Supra P, Wurm R et al (2008) The *Streptomyces coelicolor* GlnR regulon: identification of new GlnR targets and evidence for a central role of GlnR in nitrogen metabolism in actinomycetes. *Mol Microbiol* 67:861–880
- Tiffert Y, Franz-Wachtel M, Fladerer C et al (2011) Proteomic analysis of the GlnR-mediated response to nitrogen limitation in *Streptomyces coelicolor* M145. *Appl Microbiol Biotechnol* 89:1149–1159
- Torbochkina LI, Dormidoshina TA, Navol'neva IN (1965) The path of pyruvic acid synthesis in act. *Erythreus* and act. *Antibioticus* strains producing macrolide antibiotics. *Biokhimiia* 30: 388–394
- Ulanova D, Kitani S, Fukusaki E et al (2013) SdrA, a new DeoR family regulator involved in *Streptomyces avermitilis* morphological development and antibiotic production. *Appl Environ Microbiol* 79:7916–7921
- Ulrich LE, Koonin EV, Zhulin IB (2005) One-component systems dominate signal transduction in prokaryotes. *Trends Microbiol* 13:52–56
- Untrau S, Lebrihi A, Germain P et al (1992) Lysine catabolism in *Streptomyces ambofaciens* producer of macrolide antibiotic, spiramycin. *Curr Microbiol* 25:313–318
- Untrau S, Lebrihi A, Lefebvre G et al (1994) Nitrogen catabolite regulation of spiramycin production in *Streptomyces ambofaciens*. *Curr Microbiol* 28:111–118
- Valayil JM (2016) Activation of microbial silent gene clusters: genomics driven drug discovery approaches. *Biochem Anal Biochem* 5:276
- van Wezel GP, McDowall KJ (2011) The regulation of the secondary metabolism of *Streptomyces*: new links and experimental advances. *Nat Prod Rep* 28:1311–1333
- van Wezel GP, Mahr K, König M et al (2005) GlcP constitutes the major glucose uptake system of *Streptomyces coelicolor* A3(2). *Mol Microbiol* 55:624–636
- van Wezel GP, König M, Mahr K et al (2007) A new piece of an old jigsaw: glucose kinase is activated posttranslationally in a glucose transport-dependent manner in *Streptomyces coelicolor* A3(2). *J Mol Microbiol Biotechnol* 12:67–74
- Vancura A, Vancurova I, Volc J et al (1989) Alanine dehydrogenase from *Streptomyces fradiae*. Purification and properties. *Eur J Biochem* 179:221–227
- Vancurova I, Vancura A, Volc J et al (1989) A further characterization of alanine dehydrogenase from *Streptomyces aureofaciens*. *J Basic Microbiol* 29:185–189
- Vicente CM, Santos-Aberturas J, Payero TD et al (2014) PAS-LuxR transcriptional control of filipin biosynthesis in *S. avermitilis*. *Appl Microbiol Biotechnol* 98:9311–9924
- Vilches C, Mendez C, Hardisson C et al (1990) Biosynthesis of oleandomycin by *Streptomyces antibioticus*: influence of nutritional conditions and development of resistance. *J Gen Microbiol* 136:1447–1454
- Visser-Luirink G, De Laat WTA, Klop JM (2006) Fermentation of clavulanic acid at a controlled level of ammonia. *USP (US 6991925 B2)* 6:991–925
- Voelker F, Altaba S (2001) Nitrogen source governs the patterns of growth and pristinamycin production in '*Streptomyces pristinaespiralis*'. *Microbiology* 147:2447–2459
- Vu-Trong K, Gray PP (1987) Influence of ammonium on the biosynthesis of the macrolide antibiotic tylosin. *Enzyme Microb Technol* 9:590–593
- Vu-Trong K, Bhuwathanapun S, Gray PP (1980) Metabolic regulation in tylosin-producing *Streptomyces fradiae*: regulatory role of adenylate nucleotide pool and enzymes involved in biosynthesis of tylosin precursors. *Antimicrob Agents Chemoth* 17:519–525
- Vu-Trong K, Bhuwathanapun S, Gray PP (1981) Metabolic regulation in tylosin producing *Streptomyces fradiae* phosphate control of tylosin biosynthesis. *Antimicrob Agents Chemoth* 19:209–212
- Waldvogel E, Herbig A, Battke F et al (2011) The PII protein GlnK is a pleiotropic regulator for morphological differentiation and secondary metabolism in *Streptomyces coelicolor*. *Appl Microbiol Biotechnol* 92:1219–1236
- Walker MS, Walker JB (1971) Streptomycin biosynthesis. Separation and substrate specificities of phosphatases acting on guanidinodeoxy-scylo-inositol phosphate and streptomycin-(streptidino)phosphate. *J Biol Chem* 246:7034–7040

- Wallace KK, Payne GF, Speedie MK (1990) Ammonium effects on streptonigrin biosynthesis by *Streptomyces flocculus*. *J Ind Microbiol* 6:43–48
- Wang J, Zhao GP (2009) GlnR positively regulates nasA transcription in *Streptomyces coelicolor*. *Biochem Biophys Res Commun* 386:77–81
- Wang J, Wang W, Wang L et al (2011) A novel role of ‘pseudo’ $\gamma$ -butyrolactone receptors in controlling  $\gamma$ -butyrolactone biosynthesis in *Streptomyces*. *Mol Microbiol* 82:236–250
- Wang L, Tian X, Wang J et al (2009) Autoregulation of antibiotic biosynthesis by binding of the end product to an atypical response regulator. *PNAS* 106:8617–8622
- Wang R, Mast Y, Wang J et al (2013) Identification of two-component system AfsQ1/Q2 regulon and its cross-regulation with GlnR in *Streptomyces coelicolor*. *Mol Microbiol* 87:30–48
- Wang W, Ji J, Li X et al (2014) Angucyclines as signals modulate the behaviors of *Streptomyces coelicolor*. *PNAS* 111:5688–5693
- Wang Y, Cen XF, Zhao GP et al (2012) Characterization of a new GlnR binding box in the promoter of *amtB* in *Streptomyces coelicolor* inferred a PhoP/GlnR competitive binding mechanism for transcriptional regulation of *amtB*. *J Bacteriol* 194:5237–5244
- Wei J, Meng X, Wang Q (2011) Enhanced production of aureofuscin by over-expression of AURJ3M, positive regulator of aureofuscin biosynthesis in *Streptomyces aureofuscus*. *Lett Appl Microbiol* 52:322–329
- Wentzel A, Bruheim P, Øverby A et al (2012a) Optimized submerged batch fermentation strategy for systems scale studies of metabolic switching in *Streptomyces coelicolor* A3(2). *BMC Syst Biol* 6:1–16
- Wentzel A, Sletta H, Consortium S et al (2012b) Intracellular metabolite pool changes in response to nutrient depletion induced metabolic switching in *Streptomyces coelicolor*. *Metabolites* 2:178–194
- Wietzorrek A, Bibb M (1997) A novel family of proteins that regulates antibiotic production in streptomycetes appears to contain an OmpR-like DNA-binding fold. *Mol Microbiol* 25:1177–1184
- Willey JM, Gaskell AA (2011) Morphogenetic signaling molecules of the streptomycetes. *Chem Rev* 111:174–187
- Wray LV Jr, Fisher SH (1993) The *Streptomyces coelicolor glnR* gene encodes a protein similar to other bacterial response regulators. *Gene* 130:145–150
- Wray LV Jr, Atkinson MR, Fisher SH (1991) Identification and cloning of the *glnR* locus, which is required for transcription of the *glnA* gene in *Streptomyces coelicolor* A3(2). *J Bacteriol* 173:7351–7360
- Xu G, Wang J, Wang L et al (2010) ‘Pseudo’ $\gamma$ -butyrolactone receptors respond to antibiotic signals to coordinate antibiotic biosynthesis. *J Biol Chem* 285:27440–27448
- Xu Y, Willems A, Au-Yeung C et al (2012) A two-step mechanism for the activation of actinorhodin export and resistance in *Streptomyces coelicolor*. *MBio* 3:e00191-12
- Xu Z, Cen P (1999) Stimulation of avermectin B1a biosynthesis in *Streptomyces avermitilis* by feeding glucose and propionate. *Biotechnol Lett* 21:91–95
- Yamada Y (1995) Butyrolactone autoregulators, inducers of secondary metabolites, in *Streptomyces*. *Actinomycetologica* 9:57–65
- Yamada Y (1999) Autoregulatory factors and regulation of antibiotic production in *Streptomyces*. In: England R, Hobbs G, Bainton N, McRoberts DL (eds) *Microbiol signalling and communication*. Society for General Microbiology, Cambridge University Press, Cambridge, pp 177–196
- Yamamoto S, He Y, Arakawa K et al (2008)  $\gamma$ -Butyrolactone-dependent expression of the *Streptomyces* antibiotic regulatory protein gene *srrY* plays a central role in the regulatory cascade leading to lankacidin and lankamycin production in *Streptomyces rochei*. *J Bacteriol* 190:1308–1316
- Yamanaka K, Reynolds KA, Kersten RD et al (2014) Direct cloning and refactoring of a silent lipopeptide biosynthetic gene cluster yields the antibiotic taromycin A. *PNAS* 111:1957–1962
- Yang R, Liu X, Wen Y et al (2015) The PhoP transcription factor negatively regulates avermectin biosynthesis in *Streptomyces avermitilis*. *Appl Microbiol Biotechnol* 99:10547–10557
- Yang S-S, Lee C-M (2001) Effect of culture media on protease and oxytetracycline production with mycelium and protoplasts of *Streptomyces rimosus*. *World J Microbiol Biotechnol* 17:403–410

- Yao LL, Liao CH, Huang G et al (2014) GlnR-mediated regulation of nitrogen metabolism in the actinomycete *Saccharopolyspora erythraea*. *Appl Microbiol Biotechnol* 98:7935–7948
- Yi JS, Kim MS, Kim SJ et al (2015) Effects of sucrose, phosphate, and calcium carbonate on the production of pikromycin from *Streptomyces venezuelae*. *J Microbiol Biotechnol* 25:496–502
- Yoon V, Nodwell JR (2014) Activating secondary metabolism with stress and chemicals. *J Ind Microbiol Biotechnol* 41:415–424
- You D, Yin BC, Li ZH et al (2016) Sirtuin-dependent reversible lysine acetylation of glutamine synthetases reveals an autofeedback loop in nitrogen metabolism. *PNAS* 113:6653–6658
- Young MD, Kempe LL, Bader FG (1985) Effects of phosphate, glucose, and ammonium on cell growth and lincomycin production by *Streptomyces lincolnensis* in chemically defined media. *Biotechnol Bioeng* 27:327–333
- Yu H, Yao YF, Liu Y et al (2007) A complex role of *Amycolatopsis mediterranei* GlnR in nitrogen metabolism and related antibiotics production. *Arch Microbiol* 188:89–96
- Yu Q, Du A, Liu T et al (2012) The biosynthesis of the polyether antibiotic nanchangmycin is controlled by two pathway-specific transcriptional activators. *Arch Microbiol* 194:415–426
- Yu Z, Smanski MJ, Peterson RM et al (2010) Engineering of *Streptomyces platensis* MA7339 for overproduction of platencin and congeners. *Org Lett* 12:1744–1747
- Zaburannyi N, Rabyk M, Ostash B et al (2014) Insights into naturally minimised *Streptomyces albus* J1074 genome. *BMC Genomics* 15:97
- Zhang J, Demain AL (1991) Regulation of ACV synthetase in penicillin—and cephalosporin-producing microorganisms. *Biotechnol Adv* 9:623–641
- Zhou XY, Wang HZ (1995) Study of lividomycin produced by lividomycin producer M814. *J Zhejiang Univ Technol* 23:67–72
- Zhou Z, Xu Q, Bu Q et al (2015) Genome mining-directed activation of a silent angucycline biosynthetic gene cluster in *Streptomyces chattanoogensis*. *Chembiochem* 16:496–502
- Zhu CH, Lu FP, He YN et al (2007) Regulation of avilamycin biosynthesis in *Streptomyces viridochromogenes*: effects of glucose, ammonium ion, and inorganic phosphate. *Appl Microbiol Biotechnol* 73:1031–1038
- Zhu D, Wang Y, Zhang M et al (2013) Product-mediated regulation of pentalenolactone biosynthesis in *Streptomyces* species by the MarR/SlyA family activators PenR and PntR. *J Bacteriol* 195:1255–1266
- Zou Z, Du D, Zhang Y et al (2014) A  $\gamma$ -butyrolactone-sensing activator/repressor, JadR3, controls a regulatory mini-network for jadomycin biosynthesis. *Mol Microbiol* 94:490–505

Yitayal S. Anteneh and Christopher M.M. Franco

---

## 9.1 Actinobacterial Symbiosis with Microorganisms and Insects

### 9.1.1 Actinobacterial Symbiosis with Microorganisms

There is not much information about the symbiotic interaction between actinobacteria and other microorganisms. One common documented symbiotic interaction is between streptomycetes and rhizosphere fungi, where the bacteria promote the growth of the fungi (Maier et al. 2004). Specifically, formation of mycelia in the fly agaric (a known mycorrhizal fungus of Norway spruce) enhanced by auxofuran, a compound secreted by *Streptomyces* sp. AcH 505 (Riedlinger et al. 2006). Co-culturing of the two symbionts promoted the synthesis of auxofuran and WS-5995B (a powerful anti-plant pathogenic fungus) by *Streptomyces* sp. AcH 505. In the same manner, the interaction led to changes in the growth pattern, cytoskeletal structure, and levels of gene expression in fly agaric (Schrey et al. 2007).

### 9.1.2 Actinobacterial Symbiosis with Insects

Insects account for the largest percentage of all living things on earth and known by their active interactions with a myriad of microorganisms at different parts of their body (May 1988). Insects–microbe interactions mostly lead to remarkable promotion of host fitness with few exceptions which result in unwanted outcome (Douglas

---

Y.S. Anteneh • C.M.M. Franco (✉)  
Medical Biotechnology, School of Medicine, Flinders University,  
Adelaide, SA 5001, Australia  
e-mail: [ante0012@uni.flinders.edu.au](mailto:ante0012@uni.flinders.edu.au); [Chris.Franco@flinders.edu.au](mailto:Chris.Franco@flinders.edu.au)

1998). Frequently, the microorganisms provide vital nutrient components which the host cannot synthesize or are available in low levels in their diet (Douglas 1998; Zientz et al. 2004), and in return the insect host provides protection against disease causing agents (Scarborough et al. 2005; Scott et al. 2008).

### 9.1.2.1 Actinobacterial Nutritional Interaction with Insects

Unlike with other microorganisms (Kaltenpoth 2009), nutritional interaction between insects and actinobacteria is not common. One documented symbiosis occurs between some species of Hemiptera like *Pyrrhocoris apterus*, *Rhodnius prolixus*, and *Triatoma infestans* with a few genera of actinobacteria, namely *Coriobacterium*, *Rhodococcus*, and *Corynebacterium* at different parts of their body including their guts (Ben-Yakir 1987; Durvasula et al. 2008; Haas and König 1988).

The insect host acquired microorganisms from their parents (transmitted vertically) or through coprophagy (horizontally) (Durvasula et al. 2008; Kaltenpoth et al. 2009). Researchers have two views (Hill et al. 1976) about the importance of microbes to the insect host and mostly acknowledged the indispensable contribution of microbes for reproduction and development of their host (Ben-Yakir 1987; Durvasula et al. 2008; Baines 1956; Harington 1960). This beneficial interaction is manifested between microbes and *R. prolixus*, where microbes contribute to the host need for crucial vitamins (Hill et al. 1976; Baines 1956; Harington 1960).

Some species of gammaproteobacteria interact with tsetse fly and this finding highlights that, in addition to actinobacteria, some other bacteria also play a similar role in different insect hosts (Akman et al. 2002; Nogge 1981). In addition to the above insect species, some researchers isolated actinobacterial from the guts of termites and they highlight that the microbes may play a role for digestion of lignocelluloses (Breznak 1982; König and Varma 2006). As indicated above, the nutritional interaction between insects and actinobacteria was not studied well and further investigation to reveal what is going on in this symbionts is mandatory (König et al. 2006).

### 9.1.2.2 The Relationship Between Actinobacteria and Fungus-Growing Insects

Among many insect–microbe interactions, the most commonly investigated is the interaction between actinobacteria and leaf-cutting ants (Hymenoptera). The ants get their nutritional requirement from the growing fungal garden which are markedly affected by *Escovopsis*, a pathogenic fungus (Currie and Stuart 2001). The ants utilize different mechanisms (Currie and Stuart 2001; Bot et al. 2002) to protect their nutrient source and one of them is the protective role of actinobacteria (Currie et al. 1999). One such type of interaction is the role played by the genus *Pseudonocardia* (Currie et al. 2006). This actinobacterium grows in the cuticle of the ants and secretes inhibitory compounds (dentigerumycin) against *Escovopsis* without any effect on the fungus garden (Haeder et al. 2009a; Oh et al. 2009a). Some also report the ability of *Pseudonocardia* to produce in vitro agents that

inhibit the growth of *Escovopsis* (Oh et al. 2009a; Carr et al. 2012). Besides *Pseudonocardia*, other microorganisms also play vital parts to protect the fungus garden (Haeder et al. 2009b; Kost et al. 2007; Mueller et al. 2008; Sen et al. 2009). One good example is a *Streptomyces* sp. which produces candididin, an inhibitor of *Escovopsis* (Haeder et al. 2009b).

It has been observed that compounds produced by symbiotic actinobacteria exhibit different activities. On one side, *Pseudonocardia* and *Amycolatopsis* strains which were isolated from different ant species display a broad spectrum antifungal activity including the fungus garden (Sen et al. 2009). Opposite to this, in vivo infection of *Acromyrmex* nests with *Escovopsis* and *Pseudonocardia* revealed the protective role of the bacteria against the fungal pathogen (Poulsen et al. 2010).

In addition to ants, actinobacteria can also provide nutritional protective role for fungus-growing pine beetles (*Dendroctonus frontalis*) (Scott et al. 2008; Hulcr et al. 2011). In this interaction, *Streptomyces* provide antifungal compounds called mycangimycin which inhibits beetles pathogenic fungus (*Ophiostoma minus*) without causing any harm to the fungus garden (Scott et al. 2008; Oh et al. 2009b). The oral secretion of some species of beetles like *Dendroctonus rufipennis* contains actinobacteria such as a *Micrococcus luteus* which has potent antifungal activities (Cardoza et al. 2006).

### 9.1.2.3 Symbiont Actinobacteria Protect the Insect Host Against Pathogens

In addition to protecting the nutritional resources of the host, symbiotic actinobacteria also protect the insect itself against pathogens, parasitoids or predators (Scarborough et al. 2005; Kaltenpoth et al. 2005; Oliver et al. 2003). One of the most common pathogenic defenses is observed between digger wasps (genus *Philanthus*) and Candidatus *Streptomyces philanthi* (Kaltenpoth et al. 2005; Kaltenpoth et al. 2006). The symbiont *Streptomyces* grow in the special body part of female wasps (Goettler et al. 2007) and release several antibiotics (Kroiss et al. 2010) effective against different disease causing agents of the wasps (Koehler et al. 2013). This type of defensive interaction observed in more than 30 species of the genus *Philanthus* and highlight this interaction between *Streptomyces* and wasps are specific (Kaltenpoth et al. 2006).

---

## 9.2 Symbiosis and Pathogenicity in Human

### 9.2.1 Actinobacterial Symbiosis with Human

The human body is home to complex communities of microorganisms. There are about  $10^{14}$  microorganisms resident in the human body, which is nearly tenfold more compared to the total human cells (Savage 1977). These microorganisms are distributed in different anatomical sites of the body and their distribution is affected by the physicochemical nature of each site. Bacteria, due to their widespread

existence in the environment and ability to metabolize various substrates, are the most common symbionts of humans and other organisms (Dethlefsen et al. 2007; Turnbaugh et al. 2009). Many bacteria of the phylum Actinobacteria are common inhabitants of the human body and are considered as the part of normal microbial flora. *Corynebacterium*, *Rothia*, *Actinomyces*, and *Bifidobacterium* are the most common genera of actinobacteria encountered in the human body and their relative number at a particular site was most of the time associated with the health status of the host (Cho and Blaser 2012).

The following are the body distribution of common symbiotic actinobacteria in humans.

#### *Corynebacterium*

*Corynebacterium* belongs to the family Corynebacteriaceae within the suborder Corynebacterineae. The bacteria are distributed in different sites of the human body such as the trunk, legs, ear, nose, and mouth (Lemon et al. 2010). Most species of *Corynebacterium* such as *Corynebacterium jeikeium* are not associated with human disease with the exception of toxigenic *Corynebacterium diphtheria* which leads to a life threatening disease (Gao et al. 2007).

#### *Rothia*

*Rothia* belongs to the family Micrococcaceae within the suborder Micrococccineae. *Rothia dentocariosa* is the most common representative of the group and the bacteria are the common flora of the oral cavity and pharynx (Aas et al. 2005; Zaura et al. 2009).

#### *Actinomyces*

The genus *Actinomyces* is a member of the family Actinomycetaceae within the suborder Actinomycineae. *Actinomyces oris* is the most common representative of the group and like *Rothia*, this genus is the normal resident of oral cavity (Aas et al. 2005).

#### *Bifidobacterium*

*Bifidobacterium* belongs to the family Bifidobacteriaceae in the order Bifidobacteriales. *Bifidobacterium longum* is a representative species of the group and they are normally distributed in the gastrointestinal system. With the exception of *Bifidobacterium dentium*, which is an opportunistic pathogen that colonizes the oral cavity, most of the species are nonpathogenic and mostly activate the host immune system and produce pathogen inhibitory substances (Miao and Davies 2010).

Even though there is much that is not known about the specific symbiotic role of microorganisms in humans, as a group microbial flora plays roles with respect to nutrition and defending the body against pathogenic organisms. Nutritionally, microbial flora in the intestine contributes to digestion of food particles through production of vital enzymes, vitamin synthesis, and epithelial cells development

(Tappenden and Deutsch 2007). Symbiotic microorganisms also defend the human body against pathogenic microorganisms in various ways. Microbial symbionts can enhance the overall resistance of the host and thus make them allocate large amounts of resources to defend themselves; microbial symbionts can provide protection to their host by competitively excluding pathogenic microorganisms; their interaction with symbiotic microorganisms can stimulate or prime the host's immune system and thereby improve host defense against pathogens, and finally, microorganisms can produce bioactive compounds or their precursors and thereby contribute to their host's defensive chemistry (Piel 2004; Piel 2009).

## 9.2.2 Actinobacterial Human Diseases

Actinobacteria have been associated with a range of disease, where some are well known such as tuberculosis, leprosy, and diphtheria and the rest, such as nocardiosis and periodontal disease, gaining recent attention. This section will concentrate on the less well-known diseases caused by actinobacteria.

### 9.2.2.1 Actinomycetoma

Mycetoma, also known as Madura foot, is a subcutaneous disease caused by fungi (eumycetoma) and actinobacteria (actinomycetoma). The disease is distributed across the world, but most cases are between latitudes 30°N and 15°S (van de Sande 2013). A high prevalence of the disease is observed in some parts of Asia, Africa, and Latin America, where farmers are the most severely affected subset of the population (Samy et al. 2014).

#### *Causative Agents*

Mycetomas due to actinobacteria are responsible for 60% of the total disease burden in the world. *Nocardia brasiliensis*, *Nocardia asteroides*, *Actinomadura madurae*, *Actinomadura pelletieri*, and *Streptomyces somaliensis* are the most common agents of actinomycetoma and their relative frequency varies depending on geographical area and climate (Develoux et al. 1995).

#### *Pathogenesis*

Mycetoma which is caused either by bacteria (actinomycetoma) or fungi (eumycetoma) manifest by similar clinical pictures. The infection process commences following a traumatic inoculation of the bacteria into the skin followed by characteristic skin changes like tumescence with abscesses, nodules, sinuses (Fahal et al. 1998; Fahal et al. 2014), and exudate of granules from skin openings (Vera-Cabrera et al. 2012). Even though it is not clear at present why some individuals develop mycetoma while others do not, serological surveys in endemic areas indicated that those having antibodies did not develop disease and mycetoma cases may be attributed due to deficient cell mediated immunity (Mahgoub et al. 1977).



Three types of tissue reactions which are similar to tuberculosis can be recognized in the mycetoma disease process. During type 1 reaction, neutrophils engulf the grains or occasionally invade the grain and cause its fragmentation. Granulation tissues made of macrophages, lymphocytes, and plasma cells further occupy spaces outside the zone of neutrophils. There is a dominance of mononuclear cells in the periphery of where fibrous tissue is found compared to other cell types. This reaction also leads to hypertrophy of arterioles and edema in nerve cells. There are also cases of hypertrophy and hyperplasia in the sweat glands. The composition of tissue is altered in cases of type 2 reaction where grains are engulfed by macrophages and multinucleated cells rather than neutrophils. Finally, in type 3, a well-organized epithelioid granuloma with Langhans' giant cells is formed. With the exception of some fungal particles in the center of the tissue, type 3 reactions are similar to type 1 and 2. In more advanced cases, fibrosis replaces lymphoid tissue and plasma cells with Russell's bodies are also present. Both the innate and adaptive immune system together with several factors like hormonal status determine the prognosis of mycetoma (Fahal et al. 1995; Millán-Chiu et al. 2011).

#### *Diagnosis and Treatment*

Actinomycetoma are diagnosed mainly by observation of typical signs and symptoms at the level of skin, and microscopic observation of the nature of granules helps to identify the causative agents. Furthermore, culturing of the granules for specific causative agents is also possible though the identification is not straightforward. Table 9.1 contains some of the characteristic microscopic observation of granules (Welsh et al. 2012).

The treatment of choice for mycetoma varies depending on the causative agents. In the case of eumycetoma, the current practice in most tropical countries are combinations of antimycotic agents with surgical removal of the affected area. The first line of drugs for eumycetoma is Itraconazole which is administered for a long period of time (Lee et al. 1995). It can also be treated with a combination of antibiotics for more than a month, where trimethoprim–sulfamethoxazole are considered as the standard drugs (Ramam et al. 2000).

**Table 9.1** Causative agents of actinomycetoma grouped by appearance of typical intralesional grains (Welsh et al. 2012)

Agents	Color of grains
<i>Nocardia asteroides</i>	White
<i>Nocardia brasiliensis</i>	White
<i>Nocardia caviae</i>	White to yellow
<i>Nocardia farcinica</i>	White to yellow
<i>Nocardia transvalensis</i>	White
<i>Nocardia dassonvillei</i>	Cream
<i>Actinomadura madurae</i>	White to yellow or pink
<i>Actinomadura pelletieri</i>	Red
<i>Streptomyces somaliensis</i>	Yellow to brown

### 9.2.2.2 Nocardiosis

Nocardiosis is a general term for a rare disease of skin, lung, and different organs of the body with various degree of severity. The infection occurs both in immunocompetent and immunocompromised individuals.

#### *Causative agents*

Nocardiosis is caused by aerobic actinobacteria of the genus *Nocardia*. *Nocardia* differ from *Actinomyces* based on their mycolic acid content and the ability to grow in the presence of oxygen. There are more than 80 species of *Nocardia* and about 33 responsible in causing of human infection (Brown-Elliott et al. 2006a; Roth et al. 2003). Human infection mainly results due to *N. asteroides* complex which encompasses many species, where *Nocardia farcinica* is the most virulent compared to others (Wilson 2012).

#### *Pathogenesis*

*Nocardia* species are not a component of normal human flora but are distributed ubiquitously in the environment (Goodfellow and Williams 1983). At the level of the skin infection that results following a traumatic inoculation of the organisms, and from this site the bacteria spread to different parts of the body. In contrast, infection in the lung occurs following appearance of the organisms in the site from blood. Depending on the immune status of the patients, the site of infection, and the virulence of the bacteria, the clinical observation of nocardiosis varies. Suppurative necrosis and abscess are the most common manifestations of nocardiosis at the site of primary infection and the disseminated clinical picture observed mainly those with immunocompromised (Beaman and Beaman 1994).

Neutrophils and local macrophages contribute to the initial host response to nocardiosis. They inhibit and limit the spread of infection for certain degree until a specific cell-mediated response can occur. Different populations of T lymphocytes mediate a vital role in inhabiting the spread of the bacteria as it observed in different experiments in mice (Beaman and Beaman 1994; Deem et al. 1983; King et al. 1999). Even though the role of humoral immunity is not clearly identified, few studies highlight the role of antibodies to facilitate clearance of the bacteria from the circulation (Beaman 1992; Davis-Scibienski and Beaman 1980). The role of B cells for the pathogenesis of nocardial infection is not clearly indicated (Rico et al. 1982). Depending on the sites of infection, nocardiosis can be clinically present with abscesses and nodular manifestations on the lung (Georghiou and Blacklock 1992; McNeil and Brown 1994; Minero et al. 2009), skin (Smego and Gallis 1984), and different internal organs, mainly liver, kidney, and spleen (Wilson 2012; Wilson et al. 1989).

#### *Diagnosis and Treatment*

Definitive diagnosis of nocardiosis is established by microscopic observation of characteristic hyphae that form a branch at right angles. In addition, observation of acid-fast bacteria from tissue section stained by either modified Kinyoun or the Fite-Faraco staining methods is helpful (McNeil and Brown 1994).

The current drug of choice for treatment of nocardiosis are sulfonamides. Trimethoprim–sulfamethoxazole is an alternative treatment though some species such as *Nocardia otitidiscaviarum*, *Nocardia nova*, and *N. farcinica* have already developed some degree of resistance (Lerner 1996; McNeil et al. 1995). In addition to the abovementioned drugs, a number of  $\beta$ -lactam antibiotics like ceftriaxone and cefotaxime, and minocycline can be used as alternatives (Cercenado et al. 2007).

### 9.2.2.3 Actinomycosis

Actinomycosis is an infection of soft tissue that leads to sinus formation in the skin like nocardiosis. The infection occurs in all individuals irrespective of their immune status, and most of the time the clinical observation resembles tuberculosis and malignancy (Wong et al. 2011).

#### *Causative Agents*

Actinomycosis is caused by different species of *Actinomyces* which is only found in mammalian hosts. Most cases of human infection result from *Actinomyces israelii*, *Actinomyces gerencseriae*, *Actinomyces turicensis*, *Actinomyces radingae*, *Actinomyces europaeus*, *Actinomyces naeslundii*, *Actinomyces odontolyticus*, *Actinomyces viscosus*, and *Actinomyces meyeri* (Clarridge and Zhang 2002; Cone et al. 2003; Fazili et al. 2012; Pulverer et al. 2003).

#### *Pathogenesis*

Normally, *Actinomyces* exist in the oral cavity of humans and poor oral hygiene and dental caries increases the risk of infection. Any trauma in the gastrointestinal system may be attributed for initiation of the infection process (Bennhoff 1984; Eng et al. 1981). Once infection is established, the inflammatory system induces a manifestation such as an indurated area, suppuration, and sinus. In some occasion, a characteristic sulfur granules ooze out from the sinus. Generally, for a clinical picture of actinomycosis observed in human cases, namely cervicofacial, thoracic, abdominopelvic, and cerebral actinomycosis depending on the final tissue or organs primarily affected by the bacteria (Bennhoff 1984). On very rare occasions in some species of *Actinomyces*, uncommon disease such as otitis and diabetic foot ulcers (Drancourt et al. 1993; Wüst et al. 1995), and risk factors like presence of intrauterine–intravaginal devices promote the development of actinomycosis (Fiorino 1996).

#### *Diagnosis and Treatment*

The confirmatory diagnosis of actinomycosis depends on the observation of the causative agent from sterile sites. Sometimes, the characteristic sulfur granules may not appear during microbial diagnosis depending on type of the disease. Culture, Gram stain, and serology are other alternatives for diagnosis of actinomycosis depending on the site of infection (Bennhoff 1984; Lewis et al. 1995; Miller et al. 1995; Ng et al. 2012). Cases of actinomycosis are treated easily with  $\beta$ -lactams particularly penicillin G or amoxicillin (Smith et al. 2005).

#### 9.2.2.4 Whipple Disease

Whipple disease is an uncommon systemic infection caused by an unusual actinobacterium (Raoult et al. 2000; Relman et al. 1992). The disease was first discovered by George Hoyt Whipple in 1907 and considered the only disease of gastrointestinal system associated with malabsorption. However, recent observations indicate that this disease can affect most parts of the body (Relman et al. 1992; Herrmann et al. 2014), with low prevalence (Arnold et al. 2012).

##### *Causative Agents*

*Tropheryma whipplei* is the only species of this genus associated with human cases, though the relationship with its human host is still not well understood. The bacterium has unique properties compared to other actinobacteria: a rod-shaped gram-positive bacterium with a much smaller genome of 927,303 base pairs, low G+C content of 46%, deviation from Koch's postulates, and the ability to grow in human fibroblast cell lines (Raoult et al. 2000; Crapoulet et al. 2006).

##### *Pathogenesis*

By observing its closest relatives in soil, researchers speculate that the source of *T. whipplei* is environmental though it can only survive in humans or human cell lines (Crapoulet et al. 2006). However, further observation revealed that *T. whipplei* exclusively depends on humans for the disease process (Cunningham et al. 2015). The main factors contributing to the clinical picture are infiltration of the bacteria into different sites of the body and the response of host immune system which incorporates it into macrophages (Dray et al. 2007; Patel et al. 2008). These factors lead to the destruction of vital organs and result different sign symptoms such as abdominal pain and diarrhea, as a result of the infiltration of the organisms into the lamina propria of the small bowel thus affecting the normal function of villous (Cunningham et al. 2015). Beyond the gastrointestinal system, *T. whipplei* causes destruction of joints (O'Duffy et al. 1999), heart (Celard et al. 1999; Gubler et al. 1999), and central nervous system (Gerard et al. 2002) but is found rarely in the lungs (Kelly et al. 1996).

##### *Diagnosis and Treatment*

The diagnosis of Whipple's disease is established by microscopic observation of the causative agents from biopsy of duodenal endoscopy using Periodic acid–Schiff stain (Schneider et al. 2008). Furthermore, immunohistochemical and molecular testing are available for diagnosis of infection (Schneider et al. 2008).

Treatment is over a two-year period with penicillin, ampicillin, tetracycline, or co-trimoxazole (Bai et al. 2004). Treatments lasting less than a year have an approximate relapse rate of 40%. Recently, the treatment has changed to doxycycline with hydroxychloroquine for 12–18 months, with sulfonamides (sulfadiazine or sulfamethoxazole) added for treatment of neurological symptoms (Fenollar et al. 2007).

### 9.2.2.5 *Corynebacterium* Infections

The genus corynebacteria consists of rod-shaped, catalase-positive, aerobic, or facultative anaerobic gram-positive bacteria. Even though the organisms commonly exist in different body sites of humans including the skin, upper respiratory tract, gastrointestinal tract, and urogenital tract, relatively few are pathogenic. The most known of these is the etiologic agent of diphtheria, *C. diphtheriae*. Other pathogenic nondiphtherial corynebacteria include *Corynebacterium ulcerans*, *Corynebacterium pseudotuberculosis*, *Corynebacterium pyogenes*, *Corynebacterium aquaticum*, *Corynebacterium pseudodiphtheriticum* Group D2—also known as *Corynebacterium urealyticum*, Group E, and *C. jeikeium*, group JK (Coyle and Lipsky 1990; Van den Velde et al. 2006).

#### *Pathogenesis of Diphtheria*

Diphtheria is a disease characterized by local inflammation, mainly in the upper respiratory tract, caused by *C. diphtheria*. *C. diphtheria* infection is typically characterized by a local inflammation, usually in the upper respiratory tract, associated with toxin-mediated cardiac and neural disease. The major factor responsible for pathogenesis is diphtheria toxin, a potent polypeptide cytotoxic agent. Initial attachment of the bacteria at the infection site is the crucial step for pathogenesis, and once attachment is established the bacteria releases the toxin which causes protein biosynthesis to stop, resulting in cell death. The infection is mainly characterized by formation of a thick, gray, leathery membrane in the upper respiratory tract and in the worst case it blocks normal air flow. In addition to this, other toxin mediated damage occurs in different sites of the body including the heart, kidney, and central nervous system which may lead to death (De Zoysa et al. 2005; Mandlik et al. 2007; Moreira et al. 2003; Rogers et al. 2011).

#### *Pathogenesis of Diphtheroid*

Large number of corynebacteria species such as *C. ulcerans*, *C. pseudotuberculosis*, and *C. pyogenes* are responsible for causing diphtheroids and the clinical picture depends on the affected sites. The causative agents are responsible for causing skin ulcers, bacteremia and sepsis, endocarditis, prosthetic device infection, pneumonia, septic arthritis, osteomyelitis, peritonitis, suppurative lymphadenitis, prostatitis, chronic or recurrent cystitis, bladder stones, pyelonephritis, and keratitis (Camello et al. 2009; DeWinter et al. 2005; Ivanov et al. 2009; Lee et al. 2005; Manzella et al. 1995; Otsuka et al. 2005; Suzuki et al. 2007; Tarr et al. 2003; Turk et al. 2007).

#### *Diagnosis of Corynebacterium Infections*

Both clinical and microbiological examination are helpful for accurate diagnosis of *Corynebacterium* infections. Culture, histology (Albert's stain), toxin detection, and molecular techniques help to confirm cases of disease (Efstratiou et al. 2000; Bernard 2012; Torres et al. 2013).

The treatment choice of *Corynebacterium* infections depends on the type of the disease. In case of diphtheria, a range of treatment options are available such as antitoxin (Park and Atkinson 1898), and a variety of antibiotics (erythromycin or

procaine penicillin, clarithromycin, and clindamycin) (Kneen et al. 1998; Engler et al. 2001; Zasada et al. 2010). Different types of diphtheroids can also be successfully treated with different antibiotics like penicillin, macrolides, rifampin, and fluoroquinolones (Riegel et al. 1996).

### 9.2.2.6 *Mycobacterium tuberculosis*

After HIV, *Mycobacterium tuberculosis* is the next most deadly infectious diseases among adults. *M. tuberculosis* causes infection only in human and its existence in latent form contributes the infection spread to nearly 35% of individuals worldwide. Each year about 8 million TB cases are detected which is responsible for deaths of nearly 1.7 million people. In 2014, according to WHO 9.6 million individuals were diagnosed with TB and about 15% died (Lonroth and Raviglione 2008; Dheda et al. 2016).

#### *Causative Agents*

Most cases of classical TB disease are attributed to *M. tuberculosis*, *Mycobacterium bovis*, *Mycobacterium africanum*, *Mycobacterium microti*, *Mycobacterium canettii*, *Mycobacterium caprae*, and *Mycobacterium pinnipedii* (Van Soolingen et al. 1997).

The genus *Mycobacterium* contains a cell envelope unique for the group. The envelope is composed of a core of peptidoglycan, arabinogalactan, and mycolic acids which are covalently linked to each other and lipoarabinomannan, a molecule believed to be interacting with the plasma membrane (McNeil and Brennan 1991). The presence of mycolic acid in their cell wall makes these bacteria resistant to different harsh environmental conditions including antibiotic exposure (Daffe and Draper 1998). *Mycobacteria* exhibit different microbial properties including lack of motility, sporulation, and various morphological forms and are weakly gram-positive, acid-fast bacilli that appear microscopically as straight or slightly curved rods, 1–4  $\mu\text{m}$  in length and 0.3–0.6  $\mu\text{m}$  wide (Barry et al. 1998).

#### *Pathogenesis*

The infection cycle of TB disease starts with inhalation of aerosols containing tubercle bacilli. The majority of the bacilli are trapped by the upper respiratory defense and only a few reach the lower part of the lung and establish infection in alveoli macrophages (Frieden et al. 2003). Once the bacteria are engulfed by macrophage, a series of changes occur which both lead to successful control of the disease and establish latency or development of active disease (Frieden et al. 2003; Jensen et al. 2005).

The outcome of TB infection is governed by the balance between host defense and bacteria (van Crevel et al. 2002; American Thoracic Society 2000). In circumstance where the immune system is intact, the bacteria will not produce any observable symptoms and most of the time the infection process ends with activation of the adaptive immune system including T lymphocyte and ultimately establish latency (van Crevel et al. 2002). In some occasions, the bacteria continue multiplying in the macrophage and result in different types of changes including granuloma formation, caseous lesions, and necrosis (Rosenkrands et al. 2002; Dheda et al. 2005). In the

case of a depressed immune system, the bacteria rather than be confined to the lungs will undergo dissemination and the bacilli appear in different parts of the body such as CNS and lymphatic system (Dheda et al. 2005).

Due to unknown reasons, few individuals experience secondary diseases following activation of latent TB. In most cases, reactivation occurs in the form of extrapulmonary TB which affects almost all internal body parts without any observable pulmonary manifestations (Tufariello et al. 2003; Hernandez-Pando et al. 2000; De Backer et al. 2006).

Individuals with active primary or secondary TB present various specific and nonspecific sign and symptom such as cough, vomiting of blood, night sweating, and weight loss (Dheda et al. 2016).

### *Diagnosis and Treatment*

A combination of clinical and microbiological data is important to reach a decision about the TB infection status of an individual (Bento et al. 2011). The most common techniques for the routine diagnosis of TB include a chest X-ray, detection of acid-fast bacilli, and sputum culture. Sometimes, interferon- $\gamma$  and tuberculin skin test are also used in some parts of the world (Escalante 2009; Lange et al. 2011).

The unusual structures of mycobacteria which prevent the entrance of antibiotics contribute to the difficulty in effective treatment of TB (Brennan and Nikaido 1995). For effective treatment, combination of anti-TB drugs is a must, where isoniazid and rifampicin are the most common combination available for routine anti-TB treatment (Lawn and Zumla 2011). The common practice for treatment of new TB cases involve administration of rifampicin, isoniazid, pyrazinamide, and ethambutol for the first two months followed by rifampicin and isoniazid for the next four months (Lawn and Zumla 2011).

### **9.2.2.7 Nontuberculous Mycobacterial Infections**

More recently, mycobacterium infections other than *M. tuberculosis* (TB) are getting clinical relevance. The infection is most of the time observed in the lung, lymphatic system, and skin (Chan and Iseman 2013).

### *Causative Agents*

The causative agents of nontuberculous mycobacteria widely distribute in the environment where huge amount of them are isolated from soil and water (Falkinham 2011). The organisms are highly resistant to common disinfectant and antibiotics due to biofilm formation (Schulze-Robbecke et al. 1992; Falkinham 2007). Nontuberculous mycobacteria are mostly categorized on the basis of growth rate as fast growers (*Mycobacterium abscessus*) and sluggish one such as *Mycobacterium avium complex* (Griffith et al. 2007).

### *Pathogenesis*

Individual acquires nontuberculous mycobacteria mainly through contact with infected water and soil. Inhalation, ingestion, and traumatic inoculation are the most common means by which the bacteria get access to the human host. There are no

documented cases of person-to-person or animal-to-person transmission of nontuberculous mycobacteria (Kankya et al. 2011).

Like TB, nontuberculous mycobacteria affect most parts of the body where pulmonary cases account the major portion (94% of all nontuberculous mycobacteria cases). In the lung, nontuberculous mycobacteria persist for long period of time with development of a range of clinical pictures including difficulty in breathing, night sweats, and production of purulent sputum (Griffith et al. 2007). Nontuberculous mycobacteria in rare occasion are responsible in causing of hot tube lung, a hypersensitivity pneumonitis, manifested by fever, cough, and difficulty in breathing (Khor et al. 2001). When nontuberculous mycobacteria occur in immunocompromised individuals, more disseminated form of the disease results with varied sign and symptoms depending on the target organ or tissue affected (von Reyn et al. 2002). Unlike TB, nontuberculous mycobacteria infection of the lymphatic system is rare and results in enlargement of lymph nodes at different sites of the body (Wolinsky 1979).

### *Diagnosis and Treatment*

Diagnosis of nontuberculous mycobacteria infection depends on observation of sign and symptoms which are supported by radiologic abnormalities and microbiologic cultures (Griffith et al. 2007). In order to facilitate clearance and reduce development of drug resistance, treatment of nontuberculous mycobacteria involves multiple antimicrobial agents. Macrolides, ethambutol, and rifamycin are the three drugs of choice. Macrolides are the most effective agents, but because of drug resistance monotherapy is not recommended. Depending on the patients status, daily therapy or intermittent, 3-times-weekly, therapy may be appropriate. Although no specific macrolide has been shown to be superior, it is generally considered that clarithromycin may be more effective whereas azithromycin is usually better tolerated (Griffith et al. 2001; Kobashi and Matsushima 2003; Tanaka et al. 1999; Wallace et al. 1996).

---

## **9.3 Actinobacterial Symbiosis and Pathogenicity in Animals**

### **9.3.1 Actinobacterial Symbiosis with Animals**

Actinobacteria adapt to survive in diverse habitats such as marine environments and within plants, and some are also known to establish intimate interaction with a range of animals including both invertebrate and vertebrates. Even though the guts of animals are not well studied, actinobacteria are known to establish close interaction with the intestinal tracts of most animals. These bacteria reside in the guts of animals either in the form of symbionts or commensals and contribute towards the successful digestion of food particles. Furthermore, the presence of these symbiotic bacteria colonizes the digestive systems of animals. Symbiotic interactions are essential for survival and reproduction because they play a crucial role in nutrition, detoxification, growth performance, and protection against



pathogenic bacteria. Some symbiotic actinobacterial species, i.e., probiotics, control bacterial diseases in livestock poultry (Maciorowski et al. 2007) and aquaculture (Defoirdt et al. 2011; Tendencia and Verreth 2011).

Actinobacteria contribute immensely towards maintaining a continuous supply of calories to animals through the conversion of various food stuffs including glycan into useable form (Bayer et al. 2008). Latha et al. (Latha and Dhanasekaran 2013) isolated various actinobacteria from feces of goats and chickens that can produce extracellular digestive enzymes, having the ability to breakdown different carbohydrate, protein, and lipid. Tan et al. (Tan et al. 2009) also reported the same observation where actinobacteria facilitate digestion of the goat's diet through production of enzymes. In addition to this, animals also get help from symbiotic microorganisms to protect themselves from pathogenic microorganisms. Microorganisms usually use three different ways to protect their host animal from pathogen. These are secretion of inhibitory compounds against pathogens, occupation of pathogen attachment sites in host, and activation of host immune system against pathogens.

### 9.3.2 Actinobacterial Diseases in Animals

Actinobacteria are also responsible for causing a range of disease both in human and animals. This section will focus on some common actinobacterial diseases of animals.

#### 9.3.2.1 Animal Nocardiosis

Animal nocardiosis is an opportunistic infection with no history of transmission from one animal to another. The disease occurs in most animals with various clinical presentations (Beaman and Sugar 1983).

##### *Causative Agents*

*Nocardia*, the causative agent of nocardiosis, has a worldwide distribution with more than 90 identified species where 30 of them known in causing of disease in animal. *N. asteroides* complex, *N. brasiliensis*, *Nocardia pseudobrasiliensis*, *Nocardia transvalensis*, and *N. otitidiscaviarum* are the most common species identified from animal disease (Roth et al. 2003; Brown-Elliott et al. 2006b; Kiska et al. 2002; Steingrube et al. 1995).

##### *Pathogenesis*

The causative agents of animal nocardiosis are widely distributed in the environment (Goodfellow and Williams 1983). Infections in livestock and companion animals caused by *Nocardia* spp. are acquired by inhalation, traumatic percutaneous introduction of the microorganism, ingestion, or by the intramammary route. The occurrence of disease and infective *Nocardia* spp. may vary geographically, influenced by animal management practices as well as environmental factors, such as dry, dusty, or windy conditions (Goodfellow and Williams 1983; Kirpensteijn and Finland 1992). Once the pathogen entered the animal host, the

balance between pathogen factors and host defense determines the fate of the infection process. These intracellular organisms are able to inhibit phagosome–lysosome fusion in neutrophils and macrophages because of the presence of mycolic acids in their bacterial cell wall. *Nocardia* is also resistant to acids, oxidative enzymes, and other enzymatic mechanisms of phagocytic cells. The bacteria antagonize the effect of neutrophils with the help of mycolic acids, major cell wall components of the bacteria, and contribute to the disease process further by releasing cell damaging toxins (Beaman and Beaman 1994; Corti and Villafane-Fiotti 2003).

Various disease manifestations were observed in animal nocardiosis. Mastitis is the most common observation in cattle where the udder becomes enlarged, edematous, and sometimes for draining sinus with granules (Ribeiro et al. 2008). Nocardiosis in horses, also known as equine nocardiosis, leads to symptoms such as severe pneumonia, pleuritis, disseminated abscesses in organs, cutaneous lesions, mycetomas (Biberstein et al. 1985), and rarely, abortion (Erol et al. 2012a). Nocardiosis in cats and dogs display several types of symptoms. Skin lesions in the form of abscesses, ulcer, or mycetoma appear in different parts of their body. At the lungs, difficulty in breathing, cough, and nasal discharge are a common observation. Most internal organs including kidney and liver are affected with common clinical picture of single or multiple lesions (Ribeiro et al. 2008; Bradney 1985; Tilgner and Anstey 1996).

#### *Diagnosis and Treatment*

The routine diagnosis of animal nocardiosis depends on data from epidemiological, clinical, and microbiological investigations. In a clinical laboratory, nocardiosis is diagnosed by culturing of different specimens on artificial media where the bacteria produce a characteristic morphology (Kiska et al. 2002; Saubolle and Sussland 2003). Other laboratory tests like Modified Ziehl–Neelsen stain and differential cell count aid for diagnosis of nocardiosis (Brown-Elliott et al. 2006a; Ribeiro et al. 2008).

The best practice for treatment of animal nocardiosis is prolonged administration of antibiotics (Corti and Villafane-Fiotti 2003; Marino and Jaggy 1993) and surgical removal of the affected parts (Kirpensteijn and Fingland 1992; Bradney 1985; Tilgner and Anstey 1996). Several options of antibiotics including  $\beta$ -lactam and trimethoprim–sulfonamides are available for treatment of animal nocardiosis (Harada et al. 2009).

#### **9.3.2.2 Dermatophilosis**

The disease was first described in 1910 by Van Saceghem (Van Saceghem 1915) in the Belgian Congo as “contagious dermatitis” (*dermatose contagieuse*) in cattle. In 1926, the disease was named as streptothricosis or lumpy wool disease to refer to the disorder observed in sheep, a name that was later abandoned to avoid etiological confusion (Dean et al. 1961). Since then, cases of dermatophilosis are reported from several animals such as cows, sheep, and horses, but it is also observed in goats and pigs. The disease is rarely found in dogs and cats (Zaria 1993). In humans, very few cases have been reported (Burd et al. 2007; Harman et al. 2001).

### *Causative Agents*

*Dermatophilus congolensis* is the organism responsible for dermatophilosis, and they are under the family of Dermatophilaceae, and order Actinomycetales. They are gram positive, have two morphological forms (hyphae and motile zoospores), and can grow at different levels of oxygen (Gordon and Edwards 1963; Robert 1961).

### *Pathogenesis*

Even though attempts to isolate *Dermatophilus* from the soil were not successful, the bacteria may be soil saprophyte. Infection in animals is expected to result either following contact with infected animal, contaminated environment, or due to insect bite (Zaria 1993).

The infection is generally confined to the skin and appears as a proliferative and exudative dermatitis with subsequent formation of scabs. The infection process may be acute, subacute, or chronic (Zaria 1993). *D. congolensis* is usually limited to the epidermis, attacking the keratin of the stratum corneum of skin, hair, and wool of infected animals. The first step in the infection process is the adherence of zoospores into the skin, an area where the host defense mechanism is compromised. Conditions like low CO<sub>2</sub> concentration facilitate the spread of zoospores to the target site at which they transform to hyphae. This hyphal form is responsible for epidermal cell penetration and dissemination to different target sites. The inflammatory cascade that is initiated during hyphal penetration contributes to the development of observable clinical pictures (Robert 1961; Chatikobo et al. 2004; Abu-Samra 1979).

The clinical picture of dermatophilosis differs from animal to animal. In cattle, the most common presentations are formation of lesions, yellow-green scabs, and hair loss as observed in different body parts (Ali-Emmanuel et al. 2003; Loria et al. 2005). Almost similar signs and symptoms as in cattle appear in horses with rare experience of scabs (Szczepanik et al. 2006). Dermatophilosis in sheep also known as lumpy wool infections is characterized by formation of crusts in dorsal body parts, and appearance of pyramid shaped scabs in the wool fibers (Sekin et al. 2002).

### *Diagnosis and Treatment*

The diagnosis of dermatophilosis depends on the clinical picture, microscopy, and culturing of bacteria in different media such as blood agar. The bacteria display various types of colony characteristics, pigment production, and hyphae formation (Zaria 1993; Kaya et al. 2000).

Organisms are susceptible to a wide range of antimicrobials such as erythromycin, spiramycin, penicillin G, ampicillin, chloramphenicol, streptomycin, amoxicillin, tetracyclines, and novobiocin. Long-acting oxytetracycline for 2 days –1 day apart is curative in 85% of cattle and 100% of sheep, compared with cure rates of 71% in cattle and 80% in sheep for a single dose. In food-producing animals, topical applications of lime sulfur are a cost-effective adjuvant to antibacterial therapy (Zaria 1993).

### 9.3.2.3 Caseous Lymphadenitis in Sheep and Goats

Caseous lymphadenitis is a long-lasting inflammation of lymph nodes in animals, mostly in sheep and goats. The diseases distribute worldwide and have economic importance due to negative effect on hide and wool industries (Braga et al. 2006; Rizvi et al. 1997; Dorella et al. 2006).

#### *Causative Agent*

*C. pseudotuberculosis* is the bacterium responsible for causing caseous lymphadenitis. They are under the genus *Corynebacterium*, family Corynebacteriaceae, sub-order Corynebacterineae, order Actinomycetales, subclass Actinobacteridae, and class Actinobacteria (Stackebrandt et al. 1997). The detailed microbial components of these bacteria resemble those of *Rhodococcus*, *Mycobacterium*, and *Nocardia*. *C. pseudotuberculosis* occurs in multiple morphological forms and can survive inside and outside of host cells (Dorella et al. 2006).

#### *Pathogenesis*

Both symptomatic and asymptomatic animals with caseous lymphadenitis are the sources of infection, and they are responsible for contamination of the environment where other animals can easily acquire it. The infection process mostly occurs after traumatic injury where the bacteria get access to deep tissue and establish the first phase of infection (Baird and Fontaine 2007; O'Reilly et al. 2008). In rare circumstance, the bacteria may get access to animal body either through ingestion or inhalation. From the primary site of infection, the bacteria with the help of lymphatic system reach to lymph nodes and other body parts of animal to establish the final stage of infection process. The continuous interaction of several bacterial and host factors is responsible for initiation of inflammatory reaction at the target sites which leads to development of typical abscess of caseous lymphadenitis (Dorella et al. 2006; Paton 2010). At its advanced stage, caseous lymphadenitis is known with unique clinical presentation pronounced by abscesses in surface lymph node. Sometimes, lesion may occur in the internal organs such as lung and mediastinal lymph nodes (Fontaine and Baird 2008). In severe cases, purulent discharges may ooze out from enlarged lymph nodes and release to the surrounding environments (Dorella et al. 2006; Williamson 2001).

#### *Diagnosis and Treatment*

*C. pseudotuberculosis* can be successfully isolated on microbiological media and isolation is mostly performed in the presence of oxygen. Factors like serum facilitate the growth rate of this bacterium (Oreiby 2015). *C. pseudotuberculosis* infection in sheep and goats can also be diagnosed using several methods such as gene detection, serology, and antitoxin neutralization (Baird and Fontaine 2007; Oreiby 2015; Cetinkaya et al. 2002). Unlike most actinobacterial disease of animal, caseous lymphadenitis is not successfully treated with antibiotics. The most common practices for treating this disease involve abscess drainage, cleaning with 10% iodine, and even removal of infected lymph nodes (Nozaki et al. 2000; Olson et al. 2002).

### 9.3.2.4 Nocardioform Placentitis in Horses

Nocardioform placentitis is a horse disease reported for the first time in the USA by late 1980s (Donahue and Williams 2000; Hong et al. 1993). Nocardioform actinomycetes, a group of gram-positive branching bacteria, is responsible in causing of nocardioform placentitis. Three species of nocardioform actinomycetes, namely *Streptomyces*, *Amycolatopsis*, and *Crossiella equi* are frequently isolated from cases of horse placentitis (Donahue et al. 2002; Labeda et al. 2003; Labeda et al. 2009). A 2012 study of horses in Kentucky revealed that *C. equi* and *Amycolatopsis* share 85.5% of the total cases of nocardioform placentitis (Erol et al. 2012a).

#### *Pathogenesis*

There is insufficient information about mode of transmission and infection process of nocardioform placentitis. It is believed that the bacteria from primary entry site reach into the placenta through blood. Different pathological changes are observed at the level of placenta including necrosis and mucopurulent discharges. Hyperplastic changes also occur in villous, allantoic, and chorionic epithelium. All these changes lead placental insufficiency which affects the normal developmental cycle of the fetus. Clinically, nocardioform placentitis is manifested by late term abortion, still-birth, and prematurity (Hong et al. 1993).

#### *Diagnosis and Treatment*

Diagnosis of nocardioform placentitis solely depends on clinical observation as culturing of causative agents from placenta is not possible (Erol et al. 2012b). Clinical diagnosis is largely based on ultrasonographic examination of the uteroplacental junction (LeBlanc 2010).

Nocardioform actinomycetes responsible for placentitis respond to a range of antibiotics. Doxycycline, linezolid, minocycline, amikacin, ceftriaxone, amoxicillin–clavulanic acid, and TMP–SMX can be used for treatment of cases (Erol et al. 2012b; Rose et al. 2008; Uhde et al. 2010).

---

## 9.4 Actinobacterial Symbiosis and Pathogenicity with Plants

### 9.4.1 Actinobacterial Symbiosis with Plants

Actinobacteria also associate with plants both as symbionts and pathogens. Endophytic actinobacteria are ubiquitous in most plant species, particularly in those growing in the field, and they form intimate associations with their plant hosts without any detrimental symptoms. *Frankia* appears to be the only actinobacterial genus that forms a special organelle, an actinorhizal nodule that results from colonization of certain host plants.

Some endophytic actinobacteria have been reported to promote the growth of their host plants as well as to reduce disease symptoms caused by plant pathogens and various environmental stresses. On the contrary, it was observed that axenic plants display a lower degree of stress tolerance (Hallmann et al. 1997).

In exchange for nutrition and protection, the endophytic actinobacteria grant improved fitness to the host plants by producing a variety of bioactive metabolites. Growth stimulation of plants by endophytes is usually via the production of phytohormones, biocontrol of phytopathogens through production of antibiotics or siderophores, nutrient competition, and induction of systemic disease resistance (Bailey et al. 2006; Benhamou et al. 1998; Idris et al. 2004; Ramamoorthy et al. 2001).

### *Frankia*

Actinobacteria of genus *Frankia* and actinorrhizal plants, which encompass over 220 angiosperm species belonging to 8 families and 25 genera, form an actinorrhizal symbiosis (Wheatley 2009) that results in the development of root nodules (Mallet and Roy 2014; Benson and Silvester 1993). The genus *Frankia* adopts four morphological forms—hyphae, vesicles, sporangia, and reproductive torulose hyphae (Diem and Dommergues 1985). The vesicles harbor the enzyme nitrogenase which fixes atmospheric nitrogen either symbiotically or saprophytically (Normand et al. 2007). Inside the root nodule, *Frankia* fixes nitrogen, by converting atmospheric N<sub>2</sub> into biologically useful ammonia, which meets most of the plant's nitrogen requirements. This symbiosis allows actinorrhizal plants to invade and proliferate in soils that are low in nitrogen (Benson and Silvester 1993).

### *Non-Frankia Actinobacterial Symbionts*

Endophytic actinobacteria, like their counterparts found in soil, are prolific antibiotic producers. It is believed that antibiotics are the major mechanism in the biocontrol of plant pathogens. In order to study this function, Igarashi and his colleagues isolated about 400 actinobacteria strains from leaves, stems, and roots of plants. The fermentation products of some isolates demonstrated inhibitory activities against phytopathogenic fungi and bacteria (Igarashi et al. 2002a). A similar study with metabolites produced by a *Streptomyces* sp. collected from *Allium fistulosum* could suppress the infection of *Alternaria brassicicola* on Chinese cabbage seedlings (Igarashi et al. 2000). This protection depends on the production of fistupyrene, a novel plant protective compound. The findings from these experiments suggest that endophytic actinobacteria have the potential to produce antimicrobial compounds which probably contribute to competition with other microorganisms in host plants (Igarashi et al. 2002a; Igarashi et al. 2000). However, we have yet to see the evidence of production of any antibiotic in the rhizosphere.

Kloepper and Schroth first defined bacteria that enhance plant growth following inoculation onto seeds (Kloepper and Schroth 1978). These plant growth-promoting rhizobacteria (PGPR) promote plant growth directly via production of plant growth regulators (Patten and Glick 2002), enhanced iron availability via production of siderophores (Carrillo-Castañeda et al. 2002), nitrogen fixation (Madhaiyan et al. 2009), promoting symbiosis between nitrogen-fixing microorganisms or mycorrhiza and plants (Poole et al. 2001), solubilization of mineral phosphate (Hamdali et al. 2008), and alleviation of stress (Siddikee et al. 2010). Researchers isolated pteridic acids A and B produced by an endophytic *Streptomyces hygrosopicus*

TP-A045 that originated from plant *Pteridium aquilinum*, which has plant growth promotion activity by production of auxin (Igarashi et al. 2002b). Comparable to growth acceleration observed in indole acetic acid, these compounds at a concentration of 1 nM accelerated the formation of adventitious roots in hypocotyls of kidney beans. Even though it is not proven in plants, several species of *Streptomyces* including *Streptomyces violaceus*, *Streptomyces griseus*, *Streptomyces exfoliates*, *Streptomyces coelicolor*, and *Streptomyces lividans* were reported to secrete indole-3-acetic acid (IAA) when provided with L-tryptophan in in vitro experiments (Manulis et al. 1994). Recently, Meguro et al. (Hasegawa et al. 2006a) reported a *Streptomyces* sp. MBR-52 that accelerated emergence and elongation of plant adventitious roots.

Actinobacteria not only produce plant growth promoters, some also benefit their host plant by producing plant growth inhibitors which are harmful to herbs. Herbicidin H from *Streptomyces* sp. strain SANK 63997 was isolated from leaves of *Setaria viridis* var. *pachystachys*, and *g*-glutamylmethionine sulfoximine, a metabolite from strain SANK 62597 of *Microbispora* sp. recovered from *Carex kobomugi*, was converted to methionine sulfoxide which has strong herbicidal activity. Furthermore, strain SANK 61299 of *Dactylosporangium* sp. isolated from *Cucubalus* sp. was found to produce streptol and two plant growth inhibitors that inhibit germination of *Brassica rapa* (Tiwari and Gupta 2013; Hasegawa et al. 2006b). Gebhardt et al. discovered new phenazine compounds, endophenazines A-D, produced by *Streptomyces anulatus* in fermentation broth, which showed herbicidal activity against *Lemna minor* (duckweed) (Gebhardt et al. 2002). Caruso et al. isolated 71 actinobacteria from tissues of *Taxus* species and found that 10 strains (*Actinomadura*, *Actinoplanes*, *Kitasatospora*, *Micromonospora*, *Nocardioforme*, and *Streptomyces* spp.) produced taxanes, including taxol, and terpenoids which are known as the inhibitors of microtubule polymerization that are essential for host cells division, inter- and intracellular transportation (Caruso et al. 2000).

Recently, endophytic actinobacteria have proven to be effective, reliable biocontrol agents that can control pathogenic microorganisms that threaten food production. The current practice for control of pathogen in plants, the use of chemicals, introduces nontarget harmful effects to the environment and susceptible to development of resistance (Compant et al. 2005). As a result of this, biological control has been considered an alternative means of reducing the use of agrochemicals in food production. The earliest biocontrol effects of endophytic actinobacteria reported by Smith where *Micromonospora* sp. was isolated from tissue section of an apparently healthy tomato plant showed a strong inhibitory effect to *Fusarium oxysporum* f. sp. *lycopersici*. He was able to re-isolate this strain, suggesting its endophytic residence in tomato (Smith 1957).

Taechowisan and Lumyong isolated 59 endophytic actinobacteria from the roots of *Zingiber officinale* and *Alpinia galanga* and most of them showed anti-fungal activity against *Candida albicans* and phytopathogenic fungi (Taechowisan and Lumyong 2003). Similarly, Tian et al. isolated 274 actinobacteria strains from surface-sterilized roots and leaves of field-grown rice plants and found that

about 50% of these strains showed antagonism to some fungal pathogens, including the rice blast fungus (Tian et al. 2004). Both reports failed to provide any evidence whether the isolated actinobacteria have any effect in field experiments. Coombs et al. (Coombs et al. 2004) reported detailed biocontrol effects of endophytic actinobacteria *in planta*. In their experiment, 38 strains of endophytic actinobacteria isolated from surface-sterilized wheat and barley roots were tested against wheat root pathogens such as *Gaeumannomyces graminis*, *Rhizoctonia solani*, and *Pythium* spp. They demonstrated that 17 of the isolates displayed statistically significant activity *in planta* against *G. graminis* var. *tritici* and some were able to control the development of disease symptoms in treated wheat plants exposed to the former two pathogens in field soil (Coombs et al. 2004).

There are several mechanisms by which endophytic biological control agent exhibits to protect their host plant against pathogenic microorganisms, including production of antibiotics and cell wall-degrading enzymes, competition for nutrients and space in and around the host plant, and induction of host resistance (Liu et al. 2012).

Plant roots secrete several nutrients that include organic acids, amino acids, sugars, vitamins, enzymes, purines/nucleosides, inorganic ions and gases, phytosiderophores, phenolics, and flavonoids (Dakora and Phillips 2002). The essential nutrients support a wide range of microorganisms, some of which can suppress phytopathogens. In case of potato scab disease in disease-conducive soil, competition for nutrients and antibiotic production were considered to be the two mechanisms by which suppression of pathogen achieved by non-pathogenic *Streptomyces scabiei* and *Streptomyces diastatochromogenes*, respectively (Neeno-Eckwall et al. 2001). Pathogen suppression through competition for iron has been another type of competition as the iron concentration in the rhizosphere is extremely low (Pal and Gardener 2006). The involvement of siderophores in pathogen suppression has been reported for several actinobacteria (Khamna et al. 2009; Macagnan et al. 2008; Sontag et al. 2006), including *Streptomyces albovinaceus*, *S. griseus*, and *Streptomyces virginiae* which inhibit the germination of basidiospores of *Moniliophthora perniciosa* (Macagnan et al. 2008).

Plants exhibit two types of nonspecific defense that gives resistance to a broad spectrum of pathogens: induced systemic resistance (ISR) and systemic acquired resistance (SAR). The type of resistance induced by rhizobacteria is called ISR and the one induced by pathogen and salicylic acid (SA) is called SAR (Schuhegger et al. 2006). Actinobacteria that are endophytic to wheat have been shown to induce defense pathways in *Arabidopsis* (Conn et al. 2008). These endophytic actinobacteria induced a low level of SAR and JA/ET gene expression. However, upon pathogen challenge, endophyte treated plants showed high level of gene expression compared with non-treated controls. In contrast to the common understanding that pathogens induce SAR pathways, Conn et al. (Conn et al. 2008) reported that the endophytic actinobacteria were able to induce both the SAR and JA/ET pathways. Induction of JA/ET pathway resulted in resistance to the bacterial pathogen *Erwinia* (now *Pectobacterium*) *carotovora* subsp. *carotovora* and induction of the SAR pathway resulted in resistance to the fungal pathogen *F. oxysporum* (Conn et al. 2008).



## 9.4.2 Actinobacterial Diseases in Plants

As discussed above, most actinobacteria interact positively with plant hosts. However, there are also some strains of actinobacteria which cause disease in plants. The scab of potatoes (*Solanum tuberosum* L.) is one of the few actinobacteria associated diseases in plants. Three main types of potato scabs were described in the literature: common scab, netted scab, and russet scab. Common scab is characterized by deep or shallow-pitted lesions on potato tubers. It has been rated among the top five diseases of potatoes by seed producers in the USA (Dees and Wanner 2012). The same symptoms are found in other root crops including carrot, radish, beet, and turnip (Bouchek-Mechiche et al. 1998; Archuleta and Easton 1981).

### *Causative Agents*

Actinobacteria of the genera *Streptomyces* are the most common agents, even though there are other bacteria associated with scab formation in plants. Phytopathogenic *Streptomyces* spp. comprise only a handful of species, including the well-studied examples *Streptomyces scabies* (Lambert and Loria 1989a), *Streptomyces acidiscabies* (Lambert and Loria 1989b), *Streptomyces turgidiscabies* (Miyajima et al. 1998), *Streptomyces europaeiscabiei* (Bouchek-Mechiche et al. 2000a), *Streptomyces stelliscabiei* (Bouchek-Mechiche et al. 2000a), *Streptomyces luridiscabiei*, *Streptomyces puniscabiei*, and *Streptomyces niveiscabiei* (Park et al. 2003). These pathogens have a broad host range but are found predominantly affecting potatoes (Loria et al. 2003).

### *Pathogenesis*

The pathogenesis of streptomycetes for the process of scab formation is different from other plant pathogenic bacteria. Regardless of plant host or tissue, entry occurs through expanding plant tissues without the requirement for natural openings or wounds, and pathogen growth proceeds both intra- and intercellularly. Clark and his colleague were the first to report penetration and internal colonization of plant host tissues by plant pathogenic *Streptomyces* (Clark and Matthews 1987). *Streptomyces ipomoeae* which grew on the surface of sweet potato fibrous roots produced an extensive hyphal networks with short branches developed along hyphae. Hyphal growth extended into the lumen of cells, through cell walls into adjacent cells.

These pathogens produce a suite of phytotoxins, secreted proteins, and phytohormones that manipulate host physiology to their advantage. Pathogenicity is considered to be an acquired phenotype because virulence factors reside on a mobilizable pathogenicity island that confers the ability to cause disease (Kers et al. 2005). The production of the phytotoxin thaxtomin, a dipeptide that is a potent inhibitor of cellulose biosynthesis, is associated with pathogenicity (Johnson et al. 2007). The biosynthesis and regulation of production of thaxtomin is well characterized (Johnson et al. 2009; Joshi et al. 2007).

Our understanding of virulence mechanisms of phytopathogenic *Streptomyces* spp. extends beyond thaxtomin and Nec1 to define the pathogenome, which includes secreted proteins and secondary metabolites (Bignell et al. 2010). Scab-causing streptomycetes possess a conserved saponin-degrading enzyme, characterized in *S. scabies*

87-22 (Seipke and Loria 2008). *S. turgidiscabies* Car8 causes the formation of leafy galls that is due to the expression of a biosynthetic gene cluster for the phytohormone, cytokinin (Joshi and Loria 2007). Multiple virulence determinants are secreted by *S. scabies* 87-22 via the twin-arginine transport (FAOSTAT, 2014) pathway and are required for full development of disease symptoms (Joshi et al. 2010). These Tat-dependent virulence determinants include a lipoprotein, a cell surface protein tethered to the outer surface of the membrane in gram-positive bacteria via a lipid modification (Hutchings et al. 2009).

Though streptomycetes are generally not thought of as plant pathogens, there are a number of *Streptomyces* species that are very successful pathogens of roots and other underground plant structures (Bouček-Mechiche et al. 2000b; Bukhalid et al. 2002; Loria et al. 2006).

---

## References

- Aas JA, Paster BJ, Stokes LN, Olsen I, Dewhirst FE (2005) Defining the normal bacterial flora of the oral cavity. *J Clin Microbiol* 43(11):5721–5732
- Abu-Samra MT (1979) A study of the ultrastructure and the life cycle of *Dermatophilus congolensis*. *J Vet Med Ser B* 26(2):110–124
- Akman L, Yamashita A, Watanabe H, Oshima K, Shiba T, Hattori M et al (2002) Genome sequence of the endocellular obligate symbiont of tsetse flies, *Wigglesworthia glossinidia*. *Nat Genet* 32(3):402–407
- Ali-Emmanuel N, Moudachirou M, Akakpo JA, Quetin-Leclercq J (2003) Treatment of bovine dermatophilosis with *Senna alata*, *Lantana camara* and *Mitracarpus scaber* leaf extracts. *J Ethnopharmacol* 86(2–3):167–171
- American Thoracic Society (2000) Diagnostic standards and classification of tuberculosis in adults and children. This official statement of the American Thoracic Society and the Centers for Disease Control and Prevention was adopted by the ATS Board of directors, July 1999. This statement was endorsed by the Council of the Infectious Disease Society of America, September 1999. *Am J Respir Crit Care Med* 161(4 Pt 1):1376–1395
- Archuleta J, Easton G (1981) The cause of deep-pitted scab of potatoes. *Am Potato J* 58(8):385–392
- Arnold CA, Moreira RK, Lam-Himlin D, De Petris G, Montgomery E (2012) Whipple disease a century after the initial description: increased recognition of unusual presentations, autoimmune comorbidities, and therapy effects. *Am J Surg Pathol* 36(7):1066–1073
- Bai JC, Mazure RM, Vazquez H, Niveloni SI, Smecuol E, Pedreira S et al (2004) Whipple's disease. *Clin Gastroenterol Hepatol* 2(10):849–860
- Bailey B, Bae H, Strem M, Roberts D, Thomas S, Crozier J et al (2006) Fungal and plant gene expression during the colonization of cacao seedlings by endophytic isolates of four *Trichoderma* species. *Planta* 224(6):1449–1464
- Baines S (1956) The role of the symbiotic bacteria in the nutrition of *Rhodnius prolixus* (Hemiptera). *J Exp Biol* 33(3):533–541
- Baird GJ, Fontaine MC (2007) *Corynebacterium pseudotuberculosis* and its role in ovine caseous lymphadenitis. *J Comp Pathol* 137(4):179–210
- Barry CE 3rd, Lee RE, Mdluli K, Sampson AE, Schroeder BG, Slayden RA et al (1998) Mycolic acids: structure, biosynthesis and physiological functions. *Prog Lipid Res* 37(2–3):143–179
- Bayer EA, Lamed R, White BA, Flint HJ (2008) From cellulosomes to cellulosomes. *Chem Rec* 8(6):364–377
- Beaman BL (1992) *Nocardia* as a pathogen of the brain: mechanisms of interactions in the murine brain—a review. *Gene* 115(1–2):213–217

- Beaman BL, Beaman L (1994) *Nocardia* species: host-parasite relationships. *Clin Microbiol Rev* 7(2):213–264
- Beaman BL, Sugar AM (1983) *Nocardia* in naturally acquired and experimental infections in animals. *J Hyg* 91(3):393–419
- Benhamou N, Kloeppe JW, Tuzun S (1998) Induction of resistance against *Fusarium* wilt of tomato by combination of chitosan with an endophytic bacterial strain: ultrastructure and cytochemistry of the host response. *Planta* 204(2):153–168
- Bennhoff DF (1984) Actinomycosis: diagnostic and therapeutic considerations and a review of 32 cases. *Laryngoscope* 94(9):1198–1217
- Benson DR, Silvester W (1993) Biology of *Frankia* strains, actinomycete symbionts of actinorhizal plants. *Microbiol Rev* 57(2):293–319
- Bento J, Silva AS, Rodrigues F, Duarte R (2011) Diagnostic tools in tuberculosis. *Acta Med Portuguesa* 24(1):145–154
- Ben-Yakir D (1987) Growth retardation of *Rhodnius prolixus* symbionts by immunizing host against *Nocardia (Rhodococcus) rhodnii*. *J Insect Physiol* 33(6):379–383
- Bernard K (2012) The genus *Corynebacterium* and other medically relevant coryneform-like bacteria. *J Clin Microbiol* 50(10):3152–3158
- Biberstein E, Jang S, Hirsh D (1985) *Nocardia asteroides* infection in horses: a review. *J Am Vet Med Assoc* 186(3):273–277
- Bignell DR, Huguet-Tapia JC, Joshi MV, Pettis GS, Loria R (2010) What does it take to be a plant pathogen: genomic insights from *Streptomyces* species. *Antonie Van Leeuwenhoek* 98(2):179–194
- Bot A, Ortius-Lechner D, Finster K, Maile R, Boomsma JJ (2002) Variable sensitivity of fungi and bacteria to compounds produced by the metapleural glands of leaf-cutting ants. *Insect Soc* 49(4):363–370
- Bouček-Mechiche K, Guerin C, Jouan B, Gardan L (1998) *Streptomyces* species isolated from potato scabs in France: numerical analysis of “biotype-100” carbon source assimilation data. *Res Microbiol* 149(9):653–663
- Bouček-Mechiche K, Gardan L, Normand P, Jouan B (2000a) DNA relatedness among strains of *Streptomyces* pathogenic to potato in France: description of three new species, *S. europaeiscabiei* sp. nov. and *S. stelliscabiei* sp. nov. associated with common scab, and *S. reticuliscabiei* sp. nov. associated with netted scab. *Int J Syst Evol Microbiol* 50(Pt 1):91–99
- Bouček-Mechiche K, Gardan L, Normand P, Jouan B (2000b) DNA relatedness among strains of *Streptomyces* pathogenic to potato in France: description of three new species, *S. europaeiscabiei* sp. nov. and *S. stelliscabiei* sp. nov. associated with common scab, and *S. reticuliscabiei* sp. nov. associated with netted scab. *Int J Syst Evol Microbiol* 50(1):91–99
- Bradney IW (1985) Vertebral osteomyelitis due to *Nocardia* in a dog. *Aust Vet J* 62(9):315–316
- Braga WU, Chavera AE, González AE (2006) Clinical, humoral, and pathologic findings in adult alpaca with experimentally induced *Corynebacterium pseudotuberculosis* infection. *Am J Vet Res* 67(9):1570–1574
- Brennan PJ, Nikaido H (1995) The envelope of mycobacteria. *Annu Rev Biochem* 64:29–63
- Breznak JA (1982) Intestinal microbiota of termites and other xylophagous insects. *Annu Rev Microbiol* 36:323–343
- Brown-Elliott BA, Brown JM, Conville PS, Wallace RJ (2006a) Clinical and laboratory features of the *Nocardia* spp. based on current molecular taxonomy. *Clin Microbiol Rev* 19(2):259–282
- Brown-Elliott BA, Brown JM, Conville PS, Wallace RJ Jr (2006b) Clinical and laboratory features of the *Nocardia* spp. based on current molecular taxonomy. *Clin Microbiol Rev* 19(2):259–282
- Bukhalid RA, Takeuchi T, Labeda D, Loria R (2002) Horizontal transfer of the plant virulence gene, *necl1*, and flanking sequences among genetically distinct *Streptomyces* strains in the Diastatochromogenes cluster. *Appl Environ Microbiol* 68(2):738–744
- Burd EM, Juzych LA, Rudrik JT, Habib F (2007) Pustular dermatitis caused by *Dermatophilus congolensis*. *J Clin Microbiol* 45(5):1655–1658

- Camello TC, Souza MC, Martins CA, Damasco PV, Marques EA, Pimenta FP et al (2009) *Corynebacterium pseudodiphtheriticum* isolated from relevant clinical sites of infection: a human pathogen overlooked in emerging countries. *Lett Appl Microbiol* 48(4):458–464
- Cardoza YJ, Klepzig KD, Raffa KF (2006) Bacteria in oral secretions of an endophytic insect inhibit antagonistic fungi. *Ecological Entomology* 31(6):636–645
- Carr G, Derbyshire ER, Caldera E, Currie CR, Clardy J (2012) Antibiotic and antimalarial quinones from fungus-growing ant-associated *Pseudonocardia* sp. *J Nat Prod* 75(10):1806–1809
- Carrillo-Castañeda G, Muñoz JJ, Peralta-Videa J, Gomez E, Tiemann K, Duarte-Gardea M et al (2002) Alfalfa growth promotion by bacteria grown under iron limiting conditions. *Adv Environ Res* 6(3):391–399
- Caruso M, Colombo A, Fedeli L, Pavesi A, Quaroni S, Saracchi M et al (2000) Isolation of endophytic fungi and actinomycetes taxane producers. *Ann Microbiol* 50(1):3–14
- Celard M, de Gevigny G, Mosnier S, Buttard P, Benito Y, Etienne J et al (1999) Polymerase chain reaction analysis for diagnosis of *Tropheryma whippelii* infective endocarditis in two patients with no previous evidence of Whipple's disease. *Clin Infect Dis* 29(5):1348–1349
- Cercenado E, Marín M, Sánchez-Martínez M, Cuevas O, Martínez-Alarcón J, Bouza E (2007) In vitro activities of tigecycline and eight other antimicrobials against different *Nocardia* species identified by molecular methods. *Antimicrob Agents Chemother* 51(3):1102–1104
- Cetinkaya B, Karahan M, Atil E, Kalin R, De Baere T, Vaneechoutte M (2002) Identification of *Corynebacterium pseudotuberculosis* isolates from sheep and goats by PCR. *Vet Microbiol* 88(1):75–83
- Chan ED, Iseman MD (2013) Underlying host risk factors for nontuberculous mycobacterial lung disease. *Semin Respir Crit Care Med* 34(1):110–123
- Chatikobo P, Kusina N, Hamudikuwanda H, Nyoni O (2004) A monitoring study on the prevalence of dermatophilosis and parafilariosis in cattle in a smallholder semi-arid farming area in Zimbabwe. *Trop Anim Health Prod* 36(3):207–215
- Cho I, Blaser MJ (2012) The human microbiome: at the interface of health and disease. *Nat Rev Genet* 13(4):260–270
- Clark C, Matthews SW (1987) Histopathology of sweet potato root infection by *Streptomyces ipomoea*. *Phytopathology* 77(10):1418–1423
- Clarridge JE 3rd, Zhang Q (2002) Genotypic diversity of clinical Actinomycetes species: phenotype, source, and disease correlation among genospecies. *J Clin Microbiol* 40(9):3442–3448
- Compant S, Duffy B, Nowak J, Clement C, Barka EA (2005) Use of plant growth-promoting bacteria for biocontrol of plant diseases: principles, mechanisms of action, and future prospects. *Appl Environ Microbiol* 71(9):4951–4959
- Cone LA, Leung MM, Hirschberg J (2003) *Actinomyces odontolyticus* bacteremia. *Emerg Infect Dis* 9(12):1629–1632
- Conn VM, Walker AR, Franco CM (2008) Endophytic actinobacteria induce defense pathways in *Arabidopsis thaliana*. *MPMI* 21(2):208–218
- Coombs JT, Michelsen PP, Franco CM (2004) Evaluation of endophytic actinobacteria as antagonists of *Gaeumannomyces graminis* var. *tritici* in wheat. *Biol Control* 29(3):359–366
- Corti ME, Villafane-Fioti MF (2003) Nocardiosis: a review. *Int J Infect Dis* 7(4):243–250
- Coyle MB, Lipsky BA (1990) Coryneform bacteria in infectious diseases: clinical and laboratory aspects. *Clin Microbiol Rev* 3(3):227–246
- Crapoulet N, Barbry P, Raoult D, Renesto P (2006) Global transcriptome analysis of *Tropheryma whippelii* in response to temperature stresses. *J Bacteriol* 188(14):5228–5239
- van Crevel R, Ottenhoff TH, van der Meer JW (2002) Innate immunity to *Mycobacterium tuberculosis*. *Clin Microbiol Rev* 15(2):294–309
- Cunningham S, Maulucci F, Zufferey P, Ribic C, Maillard MH (2015) Whipple's disease, when to think about it? *Revue Medicale Suisse* 11(484):1582. 4–6
- Currie CR, Stuart AE (2001) Weeding and grooming of pathogens in agriculture by ants. *Proc Biol Sci* 268(1471):1033–1039

- Currie CR, Scott JA, Summerbell RC, Malloch D (1999) Fungus-growing ants use antibiotic-producing bacteria to control garden parasites. *Nature* 398(6729):701–704
- Currie CR, Poulsen M, Mendenhall J, Boomsma JJ, Billen J (2006) Coevolved crypts and exocrine glands support mutualistic bacteria in fungus-growing ants. *Science (New York, NY)* 311(5757):81–83
- Daffe M, Draper P (1998) The envelope layers of mycobacteria with reference to their pathogenicity. *Adv Microb Physiol* 39:131–203
- Dakora FD, Phillips DA (2002) Root exudates as mediators of mineral acquisition in low-nutrient environments. *Plant Soil* 245(1):35–47
- Davis-Scibienski C, Beaman BL (1980) Interaction of alveolar macrophages with *Nocardia asteroides*: immunological enhancement of phagocytosis, phagosome-lysosome fusion, and microbicidal activity. *Infect Immun* 30(2):578–587
- De Backer AI, Mortelet KJ, De Keulenaer BL, Parizel PM (2006) Tuberculosis: epidemiology, manifestations, and the value of medical imaging in diagnosis. *JBR-BTR: organe de la Societe royale belge de radiologie (SRBR) = orgaan van de Koninklijke Belgische Vereniging voor Radiologie (KBVR)* 89(5):243–250
- De Zoysa A, Efstratiou A, Hawkey PM (2005) Molecular characterization of diphtheria toxin repressor (*dtxR*) genes present in nontoxigenic *Corynebacterium diphtheriae* strains isolated in the United Kingdom. *J Clin Microbiol* 43(1):223–228
- Dean D, Gordon M, Severinghaus C, Kroll E, Reilly J (1961) Streptothricosis: a new zoonotic disease. *N Y State J Med* 61(8):1283–1287
- Deem RL, Doughty FA, Beaman BL (1983) Immunologically specific direct T lymphocyte-mediated killing of *Nocardia asteroides*. *J Immunol (Baltimore, MD: 1950)* 130(5):2401–2406
- Dees MW, Wanner LA (2012) In search of better management of potato common scab. *Potato Res* 55(3–4):249–268
- Defoirdt T, Sorgeloos P, Bossier P (2011) Alternatives to antibiotics for the control of bacterial disease in aquaculture. *Curr Opin Microbiol* 14(3):251–258
- Dethlefsen L, McFall-Ngai M, Relman DA (2007) An ecological and evolutionary perspective on human-microbe mutualism and disease. *Nature* 449(7164):811–818
- Develoux M, Ndiaye B, Dieng MT (1995) Mycetomas in Africa. *Sante (Montrouge, France)* 5(4):211–217
- DeWinter LM, Bernard KA, Romney MG (2005) Human clinical isolates of *Corynebacterium diphtheriae* and *Corynebacterium ulcerans* collected in Canada from 1999 to 2003 but not fitting reporting criteria for cases of diphtheria. *J Clin Microbiol* 43(7):3447–3449
- Dheda K, Booth H, Huggett JF, Johnson MA, Zumla A, Rook GA (2005) Lung remodeling in pulmonary tuberculosis. *J Infect Dis* 192(7):1201–1209
- Dheda K, Barry CE 3rd, Maartens G (2016) Tuberculosis. *Lancet (London, England)*. 387(10024):1211–1226
- Diem HG, Dommergues Y (1985) In vitro production of specialized reproductive torulose hyphae by *Frankia* strain ORS 021001 isolated from *Casuarina junghuhniana* root nodules. *Plant Soil* 87:17–29
- Donahue JM, Williams NM (2000) Emergent causes of placentitis and abortion. *Vet Clin North Am Equine Pract* 16(3):443–56, viii
- Donahue JM, Williams NM, Sells SF, Labeda DP (2002) *Crossiella equi* sp. nov., isolated from equine placentas. *Int J Syst Evol Microbiol* 52(Pt 6):2169–2173
- Dorella FA, Pacheco LG, Oliveira SC, Miyoshi A, Azevedo V (2006) *Corynebacterium pseudotuberculosis*: microbiology, biochemical properties, pathogenesis and molecular studies of virulence. *Vet Res* 37(2):201–218
- Douglas AE (1998) Nutritional interactions in insect-microbial symbioses: aphids and their symbiotic bacteria *Buchnera*. *Annu Rev Entomol* 43:17–37
- Drancourt M, Oules O, Bouche V, Peloux Y (1993) Two cases of *Actinomyces pyogenes* infection in humans. *Eur J Clin Microbiol Infect Dis* 12(1):55–57

- Dray X, Vahedi K, Delcey V, Lavergne-Slove A, Raskine L, Bergmann JF et al (2007) *Mycobacterium avium* duodenal infection mimicking Whipple's disease in a patient with AIDS. *Endoscopy* 39(Suppl 1):E296–E297
- Durvasula RV, Sundaram RK, Kirsch P, Hurwitz I, Crawford CV, Dotson E et al (2008) Genetic transformation of a Corynebacterial symbiont from the Chagas disease vector *Triatoma infestans*. *Exp Parasitol* 119(1):94–98
- Efstratiou A, Engler KH, Mazurova IK, Glushkevich T, Vuopio-Varkila J, Popovic T (2000) Current approaches to the laboratory diagnosis of diphtheria. *J Infect Dis* 181(Suppl 1):S138–S145
- Eng RH, Corrado ML, Cleri D, Cherubin C, Goldstein EJ (1981) Infections caused by *Actinomyces viscosus*. *Am J Clin Pathol* 75(1):113–116
- Engler K, Warner M, George R (2001) *In vitro* activity of ketolides HMR 3004 and HMR 3647 and seven other antimicrobial agents against *Corynebacterium diphtheriae*. *J Antimicrob Chemother* 47(1):27–31
- Erol E, Sells SF, Williams NM, Kennedy L, Locke SJ, Labeda DP et al (2012a) An investigation of a recent outbreak of nocardioform placentitis caused abortions in horses. *Vet Microbiol* 158(3–4):425–430
- Erol E, Williams NM, Sells SF, Kennedy L, Locke SJ, Donahue JM et al (2012b) Antibiotic susceptibility patterns of *Crossiella equi* and *Amycolatopsis* species causing nocardioform placentitis in horses. *J Vet Diagn Investig* 24(6):1158–1161
- Escalante P (2009) Tuberculosis. *Ann Intern Med* 150(11):ITC61–IT614. quiz ITV6
- Fahal AH, el Toum EA, el Hassan AM, Mahgoub ES, Gumaa SA (1995) The host tissue reaction to *Madurella mycetomatis*: new classification. *J Med Vet Mycol* 33(1):15–17
- Fahal A, El Hassan A, Abdelalla A, Sheik H (1998) Cystic mycetoma: an unusual clinical presentation of *Madurella mycetomatis* infection. *Trans R Soc Trop Med Hyg* 92(1):66–67
- Fahal A, Mahgoub el S, El Hassan AM, Abdel-Rahman ME, Alshambaty Y, Hashim A et al (2014) A new model for management of mycetoma in the Sudan. *PLoS Negl Trop Dis* 8(10):e3271
- Falkinham JO 3rd (2007) Growth in catheter biofilms and antibiotic resistance of *Mycobacterium Avium*. *J Med Microbiol* 56(Pt 2):250–254
- Falkinham JO 3rd (2011) Nontuberculous mycobacteria from household plumbing of patients with nontuberculous mycobacteria disease. *Emerg Infect Dis* 17(3):419–424
- FAOSTAT 2014. Available from: <http://faostat.fao.org/site/567/DesktopDefault.aspx#ancor>
- Fazili T, Blair D, Riddell S, Kiska D, Nagra S (2012) *Actinomyces meyeri* infection: case report and review of the literature. *J Infect* 65(4):357–361
- Fenollar F, Puechal X, Raoult D (2007) Whipple's disease. *N Engl J Med* 356(1):55–66
- Fiorino AS (1996) Intrauterine contraceptive device-associated actinomycotic abscess and *Actinomyces* detection on cervical smear. *Obstet Gynecol* 87(1):142–149
- Fontaine M, Baird G (2008) Caseous lymphadenitis. *Small Rumin Res* 76(1):42–48
- Frieden TR, Sterling TR, Munsiff SS, Watt CJ, Dye C (2003) Tuberculosis. *Lancet* (London, England) 362(9387):887–899
- Gao Z, Tseng CH, Pei Z, Blaser MJ (2007) Molecular analysis of human forearm superficial skin bacterial biota. *Proc Natl Acad Sci U S A* 104(8):2927–2932
- Gebhardt K, Schimana J, Krastel P, Dettner K, Rheinheimer J, Zeeck A et al (2002) Endophenazines AD, new phenazine antibiotics from the arthropod associated endosymbiont *Streptomyces anulatus*. I. Taxonomy, fermentation, isolation and biological activities. *J Antibiot* 55(9):794–800
- Georghiou PR, Blacklock ZM (1992) Infection with *Nocardia* species in Queensland. A review of 102 clinical isolates. *Med J Aust* 156(10):692–697
- Gerard A, Sarrot-Reynauld F, Liozon E, Cathebras P, Besson G, Robin C et al (2002) Neurologic presentation of Whipple disease: report of 12 cases and review of the literature. *Medicine* 81(6):443–457
- Goettler W, Kaltenpoth M, Herzner G, Strohm E (2007) Morphology and ultrastructure of a bacteria cultivation organ: the antennal glands of female European beeswolves, *Philanthus Triangulum* (hymenoptera, Crabronidae). *Arthropod Struct Dev* 36(1):1–9
- Goodfellow M, Williams ST (1983) Ecology of actinomycetes. *Annu Rev Microbiol* 37:189–216

- Gordon MA, Edwards MR (1963) Micromorphology of *Dermatophilus congolensis*. J Bacteriol 86:1101–1115
- Griffith DE, Brown BA, Girard WM, Griffith BE, Couch LA, Wallace RJ Jr (2001) Azithromycin-containing regimens for treatment of *Mycobacterium avium* Complex lung disease. Clin Infect Dis 32(11):1547–1553
- Griffith DE, Aksamit T, Brown-Elliott BA, Catanzaro A, Daley C, Gordin F et al (2007) An official ATS/IDSA statement: diagnosis, treatment, and prevention of nontuberculous mycobacterial diseases. Am J Respir Crit Care Med 175(4):367–416
- Gubler JG, Kuster M, Dutly F, Bannwart F, Krause M, Vogelin HP et al (1999) Whipple endocarditis without overt gastrointestinal disease: report of four cases. Ann Intern Med 131(2):112–116
- Haas F, König H (1988) *Coriobacterium glomerans* gen. Nov., sp. nov. from the intestinal tract of the red soldier bug. Int J Syst Evol Microbiol 38(4):382–384
- Haeder S, Wirth R, Herz H, Spiteller D (2009a) Candicidin-producing *Streptomyces* support leaf-cutting ants to protect their fungus garden against the pathogenic fungus *Escovopsis*. Proc Natl Acad Sci U S A 106(12):4742–4746
- Haeder S, Wirth R, Herz H, Spiteller D (2009b) Candicidin-producing *Streptomyces* support leaf-cutting ants to protect their fungus garden against the pathogenic fungus *Escovopsis*. Proc Natl Acad Sci 106(12):4742–4746
- Hallmann J, Quadt-Hallmann A, Mahaffee W, Kloepper J (1997) Bacterial endophytes in agricultural crops. Can J Microbiol 43(10):895–914
- Hamdali H, Hafidi M, Virolle MJ, Ouhdouch Y (2008) Growth promotion and protection against damping-off of wheat by two rock phosphate solubilizing actinomycetes in a P-deficient soil under greenhouse conditions. Appl Soil Ecol 40(3):510–517
- Harada H, Endo Y, Sekiguchi M, Setoguchi A, Momoi Y (2009) Cutaneous nocardiosis in a cat. J Vet Med Sci 71(6):785–787
- Harington J (1960) Synthesis of thiamine and folic acid by *Nocardia rhodnii*, the micro-symbiont of *Rhodnius prolixus*. Nature 188:1027
- Harman M, Sekin S, Akdeniz S (2001) Human dermatophilosis mimicking ringworm. Br J Dermatol 145(1):170–171
- Hasegawa S, Meguro A, Shimizu M, Nishimura T, Kunoh H (2006a) The ceramic bead that is suitable for a carrier of plant-rooting accelerator, *Streptomyces* sp. MBR-52. J Jap Soc Antibiot 20(2):23–29
- Hasegawa S, Meguro A, Shimizu M, Nishimura T, Kunoh H (2006b) Endophytic actinomycetes and their interactions with host plants. J Jap Soc Antibiot 20(2):72–81
- Hernandez-Pando R, Jeyanthan M, Mengistu G, Aguilar D, Orozco H, Harboe M et al (2000) Persistence of DNA from *Mycobacterium tuberculosis* in superficially normal lung tissue during latent infection. Lancet (London, England). 356(9248):2133–2138
- Herrmann MD, Neumayr A, Essig A, Spiess J, Merk J, Moller P et al (2014) Isolated Whipple's endocarditis: an underestimated diagnosis that requires molecular analysis of surgical material. Ann Thorac Surg 98(1):e1–e3
- Hill P, Campbell JA, Petrie IA (1976) *Rhodnius prolixus* and its symbiotic actinomycete: a microbiological, physiological and behavioural study. Proc R Soc London Ser B 194(1117):501–525
- Hong CB, Donahue JM, Giles RC Jr, Petrites-Murphy MB, Poonacha KB, Roberts AW et al (1993) Etiology and pathology of equine placentitis. J Vet Diagn Investig 5(1):56–63
- Hulcr J, Adams AS, Raffa K, Hofstetter RW, Klepzig KD, Currie CR (2011) Presence and diversity of *Streptomyces* in *Dendroctonus* and sympatric bark beetle galleries across North America. Microb Ecol 61(4):759–768
- Hutchings MI, Palmer T, Harrington DJ, Sutcliffe IC (2009) Lipoprotein biogenesis in gram-positive bacteria: knowing when to hold 'em, knowing when to fold 'em. Trends Microbiol 17(1):13–21
- Idris R, Trifonova R, Puschenreiter M, Wenzel WW, Sessitsch A (2004) Bacterial communities associated with flowering plants of the Ni hyperaccumulator *Thlaspi goesingense*. Appl Environ Microbiol 70(5):2667–2677

- Igarashi Y, Ogawa M, Sato Y, Saito N, Yoshida R, Kunoh H et al (2000) Fistupyrone, a novel inhibitor of the infection of Chinese cabbage by *Alternaria brassicicola*, from *Streptomyces* sp. TP-A0569. *J Antibiot* 53(10):1117–1122
- Igarashi Y, Iida T, Sasaki T, Saito N, Yoshida R, Furumai T (2002a) Isolation of actinomycetes from live plants and evaluation of antiphytopathogenic activity of their metabolites. *J Japanese Soc Antibiot* 16(1):9–13
- Igarashi Y, Iida T, Yoshida R, Furumai T (2002b) Pteridic acids a and B, novel plant growth promoters with auxin-like activity from *Streptomyces hygroscopicus* TP-A0451. *J Antibiot* 55(8):764–767
- Ivanov IB, Kuzmin MD, Gritsenko VA (2009) Microflora of the seminal fluid of healthy men and men suffering from chronic prostatitis syndrome. *Int J Androl* 32(5):462–467
- Jensen PA, Lambert LA, Iademarco MF, Ridzon R (2005) Guidelines for preventing the transmission of *Mycobacterium tuberculosis* in health-care settings, 2005. *MMWR Recommend Rep* 54(Rr-17):1–141
- Johnson EG, Joshi MV, Gibson DM, Loria R (2007) Cello-oligosaccharides released from host plants induce pathogenicity in scab-causing *Streptomyces* species. *Physiol Mol Plant Pathol* 71(1):18–25
- Johnson EG, Krasnoff SB, Bignell DR, Chung WC, Tao T, Parry RJ et al (2009) 4-Nitrotryptophan is a substrate for the non-ribosomal peptide synthetase TxtB in the thaxtomin a biosynthetic pathway. *Mol Microbiol* 73(3):409–418
- Joshi MV, Loria R (2007) *Streptomyces turgidiscabies* possesses a functional cytokinin biosynthetic pathway and produces leafy galls. *MPMI* 20(7):751–758
- Joshi MV, Bignell DR, Johnson EG, Sparks JP, Gibson DM, Loria R (2007) The AraC/XylS regulator TxtR modulates thaxtomin biosynthesis and virulence in *Streptomyces scabies*. *Mol Microbiol* 66(3):633–642
- Joshi MV, Mann SG, Antelmann H, Widdick DA, Fyans JK, Chandra G et al (2010) The twin arginine protein transport pathway exports multiple virulence proteins in the plant pathogen *Streptomyces scabies*. *Mol Microbiol* 77(1):252–271
- Kaltenpoth M (2009) Actinobacteria as mutualists: general healthcare for insects? *Trends Microbiol* 17(12):529–535
- Kaltenpoth M, Gottler W, Herzner G, Strohm E (2005) Symbiotic bacteria protect wasp larvae from fungal infestation. *Curr Biol* 15(5):475–479
- Kaltenpoth M, Goettler W, Dale C, Stubblefield JW, Herzner G, Roeser-Mueller K et al (2006) Candidatus *Streptomyces philanthi*, an endosymbiotic streptomycete in the antennae of *Philanthus* digger wasps. *Int J Syst Evol Microbiol* 56(Pt 6):1403–1411
- Kaltenpoth M, Winter SA, Kleinhammer A (2009) Localization and transmission route of *Coriobacterium glomerans*, the endosymbiont of pyrrhocorid bugs. *FEMS Microbiol Ecol* 69(3):373–383
- Kankya C, Muwonge A, Djonje B, Munyeme M, Opuda-Asibo J, Skjerve E et al (2011) Isolation of non-tuberculous mycobacteria from pastoral ecosystems of Uganda: public health significance. *BMC Public Health* 11:320
- Kaya O, Kirkan S, Unal B (2000) Isolation of *Dermatophilus congolensis* from a cat. *J Vet Med Ser B* 47(2):155–157
- Kelly CA, Egan M, Rawlinson J (1996) Whipple's disease presenting with lung involvement. *Thorax* 51(3):343–344
- Kers JA, Cameron KD, Joshi MV, Bukhalid RA, Morello JE, Wach MJ et al (2005) A large, mobile pathogenicity island confers plant pathogenicity on *Streptomyces* species. *Mol Microbiol* 55(4):1025–1033
- Khamna S, Yokota A, Lumyong S (2009) Actinomycetes isolated from medicinal plant rhizosphere soils: diversity and screening of antifungal compounds, indole-3-acetic acid and siderophore production. *World J Microbiol Biotechnol* 25(4):649–655
- Khoo A, Leslie KO, Tazelaar HD, Helmers RA, Colby TV (2001) Diffuse pulmonary disease caused by nontuberculous mycobacteria in immunocompetent people (hot tub lung). *Am J Clin Pathol* 115(5):755–762



- King DP, Hyde DM, Jackson KA, Novosad DM, Ellis TN, Putney L et al (1999) Cutting edge: protective response to pulmonary injury requires gamma delta T lymphocytes. *J Immunol* (Baltimore, MD: 1950) 162(9):5033–5036
- Kirpensteijn J, Fingland R (1992) Cutaneous actinomycosis and nocardiosis in dogs: 48 cases (1980–1990). *J Am Vet Med Assoc* 201(6):917–920
- Kiska DL, Hicks K, Pettit DJ (2002) Identification of medically relevant *Nocardia* species with an abbreviated battery of tests. *J Clin Microbiol* 40(4):1346–1351
- Kloepper J, Schroth M (1978) Plant growth-promoting rhizobacteria on radishes. In: Proceedings of the 4th international conference on plant pathogenic bacteria. Gilbert-Clarey, Tours, France
- Kneen R, Pham NG, Solomon T, Tran TM, Nguyen TT, Tran BL et al (1998) Penicillin vs. erythromycin in the treatment of diphtheria. *Clin Infect Dis* 27(4):845–850
- Kobashi Y, Matsushima T (2003) The effect of combined therapy according to the guidelines for the treatment of *Mycobacterium avium* Complex pulmonary disease. *Internal medicine* (Tokyo, Japan) 42(8):670–675
- Koehler S, Doubtsky J, Kaltenpoth M (2013) Dynamics of symbiont-mediated antibiotic production reveal efficient long-term protection for bee wolf offspring. *Front Zool* 10(1):3
- König H, Varma A (2006) Intestinal microorganisms of termites and other invertebrates. Springer Science and Business Media, New York
- König H, Fröhlich J, Hertel H (2006) Diversity and lignocellulolytic activities of cultured microorganisms. In: Intestinal microorganisms of termites and other invertebrates. Springer, New York, pp 271–301
- Kost C, Lakatos T, Bottcher I, Arendholz WR, Redenbach M, Wirth R (2007) Non-specific association between filamentous bacteria and fungus-growing ants. *Naturwissenschaften* 94(10):821–828
- Kroiss J, Kaltenpoth M, Schneider B, Schwinger M-G, Hertweck C, Maddula RK et al (2010) Symbiotic streptomycetes provide antibiotic combination prophylaxis for wasp offspring. *Nat Chem Biol* 6(4):261–263
- Labeda DP, Donahue JM, Williams NM, Sells SF, Henton MM (2003) *Amycolatopsis kentuckyensis* sp. nov., *Amycolatopsis lexingtonensis* sp. nov. and *Amycolatopsis pretoriensis* sp. nov., isolated from equine placentas. *Int J Syst Evol Microbiol* 53(Pt 5):1601–1605
- Labeda DP, Price NP, Kroppenstedt RM, Donahue JM, Williams NM, Sells SF (2009) *Streptomyces atriruber* sp. nov. and *Streptomyces silaceus* sp. nov., two novel species of equine origin. *Int J Syst Evol Microbiol* 59(Pt 11):2899–2903
- Lambert D, Loria R (1989a) *Streptomyces scabies* sp. nov., nom. rev. *Int J Syst Evol Microbiol* 39(4):387–392
- Lambert D, Loria R (1989b) *Streptomyces acidiscabies* sp. nov. *Int J Syst Evol Microbiol* 39(4):393–396
- Lange C, Sester M, Sotgiu G, Giehler C, Girardi E, Bossink A et al (2011) Interferon- $\gamma$  release assays for diagnosis of active pleural tuberculosis: a developing world perspective. *Eur Respir J* 38(3):747–748
- Latha S, Dhanasekaran D (2013) Antibacterial and extracellular enzyme activities of gut actinobacteria isolated from *Gallus gallus Domesticus* and *Capra hircus*. *J Chem Pharm Res* 5(11):379–385
- Lawn SD, Zumla AI (2011) Tuberculosis. *Lancet* (London, England). 378(9785):57–72
- LeBlanc MM (2010) Ascending placentitis in the mare: an update. *Reproduction in domestic animals. Zuchtthygiene* 45(Suppl 2):28–34
- Lee MW, Kim JC, Choi JS, Kim KH, Greer DL (1995) Mycetoma caused by *Acremonium falci-forme*: successful treatment with itraconazole. *J Am Acad Dermatol* 32(5):897–900
- Lee PP, Ferguson DA Jr, Sarubbi FA (2005) *Corynebacterium striatum*: an underappreciated community and nosocomial pathogen. *J Infect* 50(4):338–343
- Lemon KP, Klepac-Ceraj V, Schiffer HK, Brodie EL, Lynch SV, Kolter R (2010) Comparative analyses of the bacterial microbiota of the human nostril and oropharynx. *MBio* 1(3)
- Lerner PI (1996) Nocardiosis. *Clin Infect Dis* 22(6):891–903

- Lewis R, McKenzie D, Bagg J, Dickie A (1995) Experience with a novel selective medium for isolation of *Actinomyces* spp. from medical and dental specimens. *J Clin Microbiol* 33(6):1613–1616
- Liu X, Bolla K, Ashforth EJ, Zhuo Y, Gao H, Huang P et al (2012) Systematics-guided bio-prospecting for bioactive microbial natural products. *Antonie Van Leeuwenhoek* 101(1):55–66
- Lonnroth K, Raviglione M (2008) Global epidemiology of tuberculosis: prospects for control. *Semin Respir Crit Care Med* 29(5):481–491
- Loria R, Coombs J, Yoshida M, Kers J, Bukhalid R (2003) A paucity of bacterial root diseases: *Streptomyces* succeeds where others fail. *Physiol Mol Plant Pathol* 62(2):65–72
- Loria GR, La Barbera E, Monteverde V, Sparagano OA, Caraccappa S (2005) Dermatophilosis in goats in Sicily. *Vet Rec* 156(4):120–121
- Loria R, Kers J, Joshi M (2006) Evolution of plant pathogenicity in *Streptomyces*. *Annu Rev Phytopathol* 44:469–487
- Macagnan D, Romeiro RS, Pomella AW (2008) Production of lytic enzymes and siderophores, and inhibition of germination of basidiospores of *Moniliophthora* (ex *Crinipellis*) *perniciosa* by phylloplane actinomycetes. *Biol Control* 47(3):309–314
- Maciorowski K, Herrera P, Jones F, Pillai S, Ricke S (2007) Effects on poultry and livestock of feed contamination with bacteria and fungi. *Anim Feed Sci Technol* 133(1):109–136
- Madhaiyan M, Poonguzhali S, Senthilkumar M, Sundaram S, Sa T (2009) Nodulation and plant-growth promotion by methylotrophic bacteria isolated from tropical legumes. *Microbiol Res* 164(1):114–120
- Mahgoub ES, Gumaa SA, El Hassan AM (1977) Immunological status of mycetoma patients. *Bulletin de la Societe de pathologie exotique et de ses filiales* 70(1):48–54
- Maier A, Riedlinger J, Fiedler H-P, Hampp R (2004) Actinomycetales bacteria from a spruce stand: characterization and effects on growth of root symbiotic and plant parasitic soil fungi in dual culture. *Mycol Prog* 3(2):129–136
- Mallet P, Roy S (2014) The symbiosis between *Frankia* and alder shrubs results in a tolerance of the environmental stress associated with tailings from the Canadian oil sands industry. *J Pet Environ Biotechnol* 5. doi:10.4172/2157-7463.1000180
- Mandlik A, Swierczynski A, Das A, Ton-That H (2007) *Corynebacterium diphtheriae* employs specific minor pilins to target human pharyngeal epithelial cells. *Mol Microbiol* 64(1):111–124
- Manulis S, Shafrir H, Epstein E, Lichter A, Barash I (1994) Biosynthesis of indole-3-acetic acid via the indole-3-acetamide pathway in *Streptomyces* spp. *Microbiology* 140(5):1045–1050
- Manzella JP, Kellogg JA, Parsey KS (1995) *Corynebacterium pseudodiphtheriticum*: a respiratory tract pathogen in adults. *Clin Infect Dis* 20(1):37–40
- Marino DJ, Jaggy A (1993) Nocardiosis. A literature review with selected case reports in two dogs. *J Vet Intern Med* 7(1):4–11
- May RM (1988) How many species are there on earth? *Science (New York, NY)* 241(4872):1441–1449
- McNeil M, Brennan P (1991) Structure, function and biogenesis of the cell envelope of mycobacteria in relation to bacterial physiology, pathogenesis and drug resistance; some thoughts and possibilities arising from recent structural information. *Res Microbiol* 142(4):451–463
- McNeil MM, Brown JM (1994) The medically important aerobic actinomycetes: epidemiology and microbiology. *Clin Microbiol Rev* 7(3):357–417
- McNeil MM, Brown JM, Hutwagner LC, Schiff TA (1995) Evaluation of therapy for *Nocardia asteroides* Complex infections. *Infect Dis Clin Pract* 4(4):287
- Miao V, Davies J (2010) Actinobacteria: the good, the bad, and the ugly. *Antonie Van Leeuwenhoek* 98(2):143–150
- Millán-Chiu BE, Hernández-Hernández F, Pérez-Torres A, Méndez-Tovar LJ, López-Martínez R (2011) In situ TLR2 and TLR4 expression in a murine model of mycetoma caused by *Nocardia brasiliensis*. *FEMS Immunol Med Microbiol* 61(3):278–287

- Miller PH, Wiggs LS, Miller JM (1995) Evaluation of API an-IDENT and RapID ANA II systems for identification of *Actinomyces* species from clinical specimens. *J Clin Microbiol* 33(2):329–330
- Minero MV, Marin M, Cercenado E, Rabadan PM, Bouza E, Munoz P (2009) Nocardiosis at the turn of the century. *Medicine* 88(4):250–261
- Miyajima K, Tanaka F, Takeuchi T, Kuninaga S (1998) *Streptomyces turgidiscabies* sp. nov. *Int J Syst Bacteriol* 48(Pt 2):495–502
- Moreira LO, Andrade AF, Vale MD, Souza SM, Hirata R Jr, Asad LM et al (2003) Effects of iron limitation on adherence and cell surface carbohydrates of *Corynebacterium diphtheriae* strains. *Appl Environ Microbiol* 69(10):5907–5913
- Mueller UG, Dash D, Rabeling C, Rodrigues A (2008) Coevolution between attine ants and actinomycete bacteria: a reevaluation. *Evolution* 62(11):2894–2912
- Neeno-Eckwall EC, Kinkel LL, Schottel JL (2001) Competition and antibiosis in the biological control of potato scab. *Can J Microbiol* 47(4):332–340
- Ng L, Sim J, Eng L, Menon S, Tan T (2012) Comparison of phenotypic methods and matrix-assisted laser desorption ionisation time-of-flight mass spectrometry for the identification of aero-tolerant *Actinomyces* spp. isolated from soft-tissue infections. *Eur J Clin Microbiol Infect Dis* 31(8):1749–1752
- Nogge G (1981) Significance of symbionts for the maintenance of an optimal nutritional state for successful reproduction in hematophagous arthropods. In: *Parasitology*. Cambridge University Press, New York, pp 10011–14211
- Normand P, Queiroux C, Tisa LS, Benson DR, Rouy Z, Cruveiller S et al (2007) Exploring the genomes of *Frankia*. *Physiol Plant* 130(3):331–343
- Nozaki C, Faria M, Machado T (2000) Extirpação cirúrgica dos abscessos da linfadenite caseosa em caprinos. *Arq Inst Biol* 67:187–189
- O'Reilly K, Green LE, Malone F, Medley G (2008) Parameter estimation and simulations of a mathematical model of *Corynebacterium pseudotuberculosis* transmission in sheep. *Prev Vet Med* 83(3):242–259
- O'Duffy JD, Griffing WL, Li CY, Abdelmalek MF, Persing DH (1999) Whipple's arthritis: direct detection of *Tropheryma whippelii* in synovial fluid and tissue. *Arthritis Rheum* 42(4):812–817
- Oh DC, Poulsen M, Currie CR, Clardy J (2009a) Dentigerumycin: a bacterial mediator of an antifungal symbiosis. *Nat Chem Biol* 5(6):391–393
- Oh DC, Scott JJ, Currie CR, Clardy J (2009b) Mycangimycin, a polyene peroxide from a mutualist *Streptomyces* sp. *Org Lett* 11(3):633–636
- Oliver KM, Russell JA, Moran NA, Hunter MS (2003) Facultative bacterial symbionts in aphids confer resistance to parasitic wasps. *Proc Natl Acad Sci U S A* 100(4):1803–1807
- Olson ME, Ceri H, Morck DW, Buret AG, Read RR (2002) Biofilm bacteria: formation and comparative susceptibility to antibiotics. *Can J Vet Res* 66(2):86–92
- Oreiby AF (2015) Diagnosis of caseous lymphadenitis in sheep and goat. *Small Rumin Res* 123(1):160–166
- Otsuka Y, Kawamura Y, Koyama T, Iihara H, Ohkusu K, Ezaki T (2005) *Corynebacterium resistens* sp. nov., a new multidrug-resistant coryneform bacterium isolated from human infections. *J Clin Microbiol* 43(8):3713–3717
- Pal K, Gardener BM (2006) Biological control of plant pathogens. The plant health instructor. doi:10.1094/phi-a-2006-1117-02
- Park WH, Atkinson JP (1898) The relation of the toxicity of diphtheria toxin to its neutralizing value upon antitoxin at different stages in the growth of culture. *J Exp Med* 3(4–5):513–532
- Park DH, Kim JS, Kwon SW, Wilson C, YM Y, Hur JH et al (2003) *Streptomyces luridiscabiei* sp. nov., *Streptomyces puniscabiei* sp. nov. and *Streptomyces niveiscabiei* sp. nov., which cause potato common scab disease in Korea. *Int J Syst Evol Microbiol* 53(Pt 6):2049–2054
- Patel SJ, Huard RC, Keller C, Foca M (2008) Possible case of CNS Whipple's disease in an adolescent with AIDS. *J Int Assoc Phys AIDS Care (Chicago, IL: 2002)* 7(2):69–73

- Paton MW (2010) The epidemiology and control of caseous lymphadenitis in Australian sheep flocks. Murdoch University, Perth
- Patten CL, Glick BR (2002) Role of *Pseudomonas putida* indoleacetic acid in development of the host plant root system. Appl Environ Microbiol 68(8):3795–3801
- Piel J (2004) Metabolites from symbiotic bacteria. Nat Prod Rep 21(4):519–538
- Piel J (2009) Metabolites from symbiotic bacteria. Nat Prod Rep 26(3):338–362
- Poole EJ, Bending GD, Whipps JM, Read DJ (2001) Bacteria associated with *Pinus Sylvestris*-*Lactarius Rufus* ectomycorrhizas and their effects on mycorrhiza formation in vitro. New Phytol 151(3):743–751
- Poulsen M, Cafaro MJ, Erhardt DP, Little AE, Gerardo NM, Tebbets B et al (2010) Variation in *Pseudonocardia* antibiotic defence helps govern parasite-induced morbidity in *Acromyrmex* leaf-cutting ants. Environ Microbiol Rep 2(4):534–540
- Pulverer G, Schutt-Gerowitt H, Schaal KP (2003) Human cervicofacial actinomycoses: microbiological data for 1997 cases. Clin Infect Dis 37(4):490–497
- Ramam M, Garg T, D'Souza P, Verma KK, Khaitan BK, Singh MK et al (2000) A two-step schedule for the treatment of actinomycotic mycetomas. Acta Derm Venereol 80(5):378–380
- Ramamoorthy V, Viswanathan R, Raguchander T, Prakasam V, Samiyappan R (2001) Induction of systemic resistance by plant growth promoting rhizobacteria in crop plants against pests and diseases. Crop Prot 20(1):1–11
- Raoult D, Birg ML, La Scola B, Fournier PE, Enea M, Lepidi H et al (2000) Cultivation of the bacillus of Whipple's disease. N Engl J Med 342(9):620–625
- Relman DA, Schmidt TM, MacDermott RP, Falkow S (1992) Identification of the uncultured bacillus of Whipple's disease. N Engl J Med 327(5):293–301
- von Reyn CF, Arbeit RD, Horsburgh CR, Ristola MA, Waddell RD, Tvaroha SM et al (2002) Sources of disseminated *Mycobacterium avium* infection in AIDS. J Infect 44(3):166–170
- Ribeiro MG, Salerno T, Mattos-Guaraldi AL, Camello TC, Langoni H, Siqueira AK et al (2008) Nocardiosis: an overview and additional report of 28 cases in cattle and dogs. Rev Inst Med Trop Sao Paulo 50(3):177–185
- Rico G, Ochoa R, Oliva A, Gonzalez-Mendoza A, Walker SM, Ortiz-Ortiz L (1982) Enhanced resistance to *Nocardia brasiliensis* infection in mice depleted of antigen-specific B cells. J Immunol 129(4):1688–1693
- Riedlinger J, Schrey SD, Tarkka MT, Hampp R, Kapur M, Fiedler HP (2006) Auxofuran, a novel metabolite that stimulates the growth of fly agaric, is produced by the mycorrhiza helper bacterium *Streptomyces* strain AcH 505. Appl Environ Microbiol 72(5):3550–3557
- Riegel P, Ruimy R, Christen R, Monteil H (1996) Species identities and antimicrobial susceptibilities of corynebacteria isolated from various clinical sources. Eur J Clin Microbiol Infect Dis 15(8):657–662
- Rizvi S, Green L, Glover M (1997) Caseous lymphadenitis: an increasing cause for concern. Vet Rec 140(22):586–587
- Robert DS (1961) The life cycle of *Dermatophilus dermatonomus*, the causal agent of ovine mycotic dermatitis. Aust J Exp Biol Med Sci 39:463–476
- Rogers EA, Das A, Ton-That H (2011) Adhesion by pathogenic corynebacteria. Adv Exp Med Biol 715:91–103
- Rose CE, Brown JM, Fisher JF (2008) Brain abscess caused by *Streptomyces* infection following penetration trauma: case report and results of susceptibility analysis of 92 isolates of *Streptomyces* species submitted to the CDC from 2000 to 2004. J Clin Microbiol 46(2):821–823
- Rosenkrands I, Slayden RA, Crawford J, Aagaard C, Clifton E III, Andersen P (2002) Hypoxic response of *Mycobacterium tuberculosis* studied by metabolic labeling and proteome analysis of cellular and extracellular proteins. J Bacteriol 184(13):3485–3491
- Roth A, Andreas S, Kroppenstedt RM, Harmsen D, Mauch H (2003) Phylogeny of the genus *Nocardia* based on reassessed 16S rRNA gene sequences reveals underspeciation and division of strains classified as *Nocardia asteroides* into three established species and two unnamed taxons. J Clin Microbiol 41(2):851–856

- Samy AM, van de Sande WW, Fahal AH, Peterson AT (2014) Mapping the potential risk of mycetoma infection in Sudan and South Sudan using ecological niche modeling. *PLoS Negl Trop Dis* 8(10):e3250
- van de Sande WW (2013) Global burden of human mycetoma: a systematic review and meta-analysis. *PLoS Negl Trop Dis* 7(11):e2550
- Saubolle MA, Sussland D (2003) Nocardiosis: review of clinical and laboratory experience. *J Clin Microbiol* 41(10):4497–4501
- Savage DC (1977) Microbial ecology of the gastrointestinal tract. *Annu Rev Microbiol* 31:107–133
- Scarborough CL, Ferrari J, Godfray HC (2005) Aphid protected from pathogen by endosymbiont. *Science* (New York, NY) 310(5755):1781
- Schneider T, Moos V, Loddenkemper C, Marth T, Fenollar F, Raoult D (2008) Whipple's disease: new aspects of pathogenesis and treatment. *Lancet Infect Dis* 8(3):179–190
- Schrey SD, Salo V, Raudaskoski M, Hampp R, Nehls U, Tarkka MT (2007) Interaction with mycorrhiza helper bacterium *Streptomyces* sp. AcH 505 modifies organisation of actin cytoskeleton in the ectomycorrhizal fungus *Amanita muscaria* (fly agaric). *Curr Genet* 52(2):77–85
- Schuhegger R, Ihring A, Gantner S, Bahnweg G, Knappe C, Vogt G et al (2006) Induction of systemic resistance in tomato by N-acyl-L-homoserine lactone-producing rhizosphere bacteria. *Plant Cell Environ* 29(5):909–918
- Schulze-Robbeke R, Janning B, Fischeder R (1992) Occurrence of mycobacteria in biofilm samples. *Tuber Lung Dis* 73(3):141–144
- Scott JJ, Oh DC, Yuceer MC, Klepzig KD, Clardy J, Currie CR (2008) Bacterial protection of beetle-fungus mutualism. *Science* (New York, NY) 322(5898):63
- Seipke RF, Loria R (2008) *Streptomyces scabies* 87-22 possesses a functional tomatinase. *J Bacteriol* 190(23):7684–7692
- Sekin S, Elitok ÖM, Elitok B, Suay A (2002) Natural ovine dermatophilosis: clinical aspects and efficacy of penicillin/streptomycin treatment. *Turk J Vet Anim Sci* 26(5):1013–1019
- Sen R, Ishak HD, Estrada D, Dowd SE, Hong E, Mueller UG (2009) Generalized antifungal activity and 454-screening of *Pseudonocardia* and *Amycolatopsis* bacteria in nests of fungus-growing ants. *Proc Natl Acad Sci U S A* 106(42):17805–17810
- Siddikee MA, Chauhan PS, Anandham R, Han GH, Sa T (2010) Isolation, characterization, and use for plant growth promotion under salt stress, of ACC deaminase-producing halotolerant bacteria derived from coastal soil. *J Microbiol Biotechnol* 20(11):1577–1584
- Smego RA Jr, Gallis HA (1984) The clinical spectrum of *Nocardia brasiliensis* infection in the United States. *Rev Infect Dis* 6(2):164–180
- Smith G (1957) Inhibition of *Fusarium oxysporum* f. *lycopersici* by a species of *Micromonospora* isolated from tomato. *Phytopathology* 47(7):429–432
- Smith AJ, Hall V, Thakker B, Gemmell CG (2005) Antimicrobial susceptibility testing of *Actinomyces* species with 12 antimicrobial agents. *J Antimicrob Chemother* 56(2):407–409
- Sontag B, Gerlitz M, Paululat T, Rasser HF, Grun-Wollny I, Hansske FG (2006) Oxachelin, a novel iron chelator and antifungal agent from *Streptomyces* sp. GW9/1258. *J Antibiot* 59(10):659–663
- Stackebrandt E, Rainey FA, Ward-Rainey NL (1997) Proposal for a new hierarchic classification system, Actinobacteria classis nov. *Int J Syst Evol Microbiol* 47(2):479–491
- Steingrube VA, Brown BA, Gibson JL, Wilson RW, Brown J, Blacklock Z et al (1995) DNA amplification and restriction endonuclease analysis for differentiation of 12 species and taxa of *Nocardia*, including recognition of four new taxa within the *Nocardia asteroides* Complex. *J Clin Microbiol* 33(12):3096–3101
- Suzuki T, Iihara H, Uno T, Hara Y, Ohkusu K, Hata H et al (2007) Suture-related keratitis caused by *Corynebacterium macginleyi*. *J Clin Microbiol* 45(11):3833–3836
- Szczepanik M, Golynski M, Pomorska D, Wilkolek P, Taszkun I, Kovalik M (2006) Dermatophilosis in a horse—a case report. *Bull Vet Inst Pulawy* 50(4):619
- Taechowisan T, Lumyong S (2003) Activity of endophytic actinomycetes from roots of *Zingiber officinale* and *Alpinia galanga* against phytopathogenic fungi. *Ann Microbiol* 53(3):291–298

- Tan H, Deng Z, Cao L (2009) Isolation and characterization of actinomycetes from healthy goat faeces. *Lett Appl Microbiol* 49(2):248–253
- Tanaka E, Kimoto T, Tsuyuguchi K, Watanabe I, Matsumoto H, Niimi A et al (1999) Effect of clarithromycin regimen for *Mycobacterium avium* Complex pulmonary disease. *Am J Respir Crit Care Med* 160(3):866–872
- Tappenden KA, Deutsch AS (2007) The physiological relevance of the intestinal microbiota—contributions to human health. *J Am Coll Nutr* 26(6):679s–683s
- Tarr P, Stock F, Cooke R, Fedorko D, Lucey D (2003) Multidrug-resistant *Corynebacterium striatum* pneumonia in a heart transplant recipient. *Transpl Infect Dis* 5(1):53–58
- Tendencia EA, Verreth JA (2011) Temperature fluctuation, low salinity, water microflora: risk factors for WSSV outbreaks in *Penaeus monodon*. *The Israeli J Aquacult Bamidgheh* 63:548
- Tian X, Cao L, Tan H, Zeng Q, Jia Y, Han W et al (2004) Study on the communities of endophytic fungi and endophytic actinomycetes from rice and their antipathogenic activities in vitro. *World J Microbiol Biotechnol* 20(3):303–309
- Tilgner SL, Anstey SI (1996) Nocardial peritonitis in a cat. *Aust Vet J* 74(6):430–432
- Tiwari K, Gupta RK (2013) Diversity and isolation of rare actinomycetes: an overview. *Crit Rev Microbiol* 39(3):256–294
- Torres LFC, Ribeiro D, Hirata R Jr, Pacheco LGC, Souza MC, LSd S et al (2013) Multiplex polymerase chain reaction to identify and determine the toxigenicity of *Corynebacterium* spp with zoonotic potential and an overview of human and animal infections. *Mem Inst Oswaldo Cruz* 108(3):272–279
- Tufariello JM, Chan J, Flynn JL (2003) Latent tuberculosis: mechanisms of host and bacillus that contribute to persistent infection. *Lancet Infect Dis* 3(9):578–590
- Turk S, Korrovits P, Punab M, Mandar R (2007) Coryneform bacteria in semen of chronic prostatitis patients. *Int J Androl* 30(2):123–128
- Turnbaugh PJ, Hamady M, Yatsunenko T, Cantarel BL, Duncan A, Ley RE et al (2009) A core gut microbiome in obese and lean twins. *Nature* 457(7228):480–484
- Uhde KB, Pathak S, McCullum I Jr, Jannat-Khah DP, Shadomy SV, Dykewicz CA et al (2010) Antimicrobial-resistant nocardia isolates, United States, 1995–2004. *Clin Infect Dis* 51(12):1445–1448
- Van den Velde S, Lagrou K, Desmet K, Wauters G, Verhaegen J (2006) Species identification of corynebacteria by cellular fatty acid analysis. *Diagn Microbiol Infect Dis* 54(2):99–104
- Van Saceghem R (1915) Dermatose contagieuse (impetigo contagieux). *Bull soc path Exot* 8:354–359
- Van Soolingen D, Hoogenboezem T, De Haas PE, Hermans PW, Koedam MA, Teppema KS et al (1997) A novel pathogenic taxon of the *Mycobacterium tuberculosis* complex, Canetti: characterization of an exceptional isolate from Africa. *Int J Syst Evol Microbiol* 47(4):1236–1245
- Vera-Cabrera L, Salinas-Carmona MC, Waksman N, Messeguer-Perez J, Ocampo-Candiani J, Welsh O (2012) Host defenses in subcutaneous mycoses. *Clin Dermatol* 30(4):382–388
- Wallace RJ Jr, Brown BA, Griffith DE, Girard WM, Murphy DT (1996) Clarithromycin regimens for pulmonary *Mycobacterium avium* Complex. The first 50 patients. *Am J Respir Crit Care Med* 153(6 Pt 1):1766–1772
- Welsh O, Vera-Cabrera L, Welsh E, Salinas MC (2012) Actinomycetoma and advances in its treatment. *Clin Dermatol* 30(4):372–381
- Wheatley R (2009) Nitrogen-fixing leguminous symbioses. Nitrogen fixation: origins, applications and research progress. Volume 7. Edited by MJ Dilworth, EK James, JI Sprent and WE Newton. AA Dordrecht, The Netherlands: Springer Science.(2008), pp. 402,£ 115.50. ISBN 97-1-4020-3545-6. *Exp Agric* 45(02):239–240
- Williamson LH (2001) Caseous lymphadenitis in small ruminants. *Vet Clin North Am Food Anim Pract* 17(2):359–71, vii
- Wilson JW (2012) Nocardiosis: updates and clinical overview. *Mayo Clin Proc* 87(4):403–407
- Wilson JP, Turner HR, Kirchner KA, Chapman SW (1989) Nocardial infections in renal transplant recipients. *Medicine* 68(1):38–57

- Wolinsky E (1979) Nontuberculous mycobacteria and associated diseases. *Am Rev Respir Dis* 119(1):107–159
- Wong VK, Turmezei TD, Weston VC (2011) Actinomycosis. *BMJ (Clin Res Ed)* 343:d6099
- Wüst J, Stubbs S, Weiss N, Funke G, Collins M (1995) Assignment of *Actinomyces pyogenes*-like (CDC coryneform group E) bacteria to the genus *Actinomyces* as *Actinomyces radingae* sp. nov. and *Actinomyces turicensis* sp. nov. *Lett Appl Microbiol* 20(2):76–81
- Zaria LT (1993) *Dermatophilus congolensis* infection (Dermatophilosis) in animals and man! An update. *Comp Immunol Microbiol Infect Dis* 16(3):179–222
- Zasada AA, Baczevska-Rej M, Wardak S (2010) An increase in non-toxicogenic *Corynebacterium diphtheriae* infections in Poland—molecular epidemiology and antimicrobial susceptibility of strains isolated from past outbreaks and those currently circulating in Poland. *Int J Infect Dis* 14(10):e907–ee12
- Zaura E, Keijsers BJ, Huse SM, Crielaard W (2009) Defining the healthy "core microbiome" of oral microbial communities. *BMC Microbiol* 9(1):1–12
- Zientz E, Dandekar T, Gross R (2004) Metabolic interdependence of obligate intracellular bacteria and their insect hosts. *Microbiol Mol Biol Rev* 68(4):745–770

Javad Hamed, Naghmeh Poorinmohammad,  
and Joachim Wink

---

## 10.1 Color Codes of Biotechnology

Generally, biotechnology has been undergone several classifications based on the service and benefit it gives. One of the most popularly used classifications is the color code of biotechnology where a color is attributed to a specific area where biotechnology can greatly help. Table 10.1 illustrates this classification. Although several other colors are also defined by some authors such as dark biotechnology connected with bioterrorism and biological weapons or violet one, which deals with law and ethical and philosophic issues, Table 10.1 shows the most popular and feasible code being used to classify biotechnology.

Microorganisms are well known for their great potential in every single area mentioned in Table 10.1, from their implementation in producing high-value antibiotics, organic acids, and ethanol to the production of therapeutic recombinant proteins. In this regard, the wide metabolic potential of actinobacteria has resulted in a huge attention being attracted to these bacteria in a biotechnological perspective. Other than antibiotics for the production of which actinobacteria are famous, various metabolites are found to be produced by these bacteria being beneficial in different sections of medical, environmental, and industrial concept.

---

J. Hamed (✉) • N. Poorinmohammad  
Department of Microbial Biotechnology, School of Biology and Center of Excellence in  
Phylogeny of Living Organisms, College of Science, University of Tehran, Tehran, Iran  
Microbial Technology and Products Research Center, University of Tehran, Tehran, Iran  
e-mail: [jhamed@ut.ac.ir](mailto:jhamed@ut.ac.ir)

J. Wink  
Helmholtz Center for Infection Research, Braunschweig, Germany



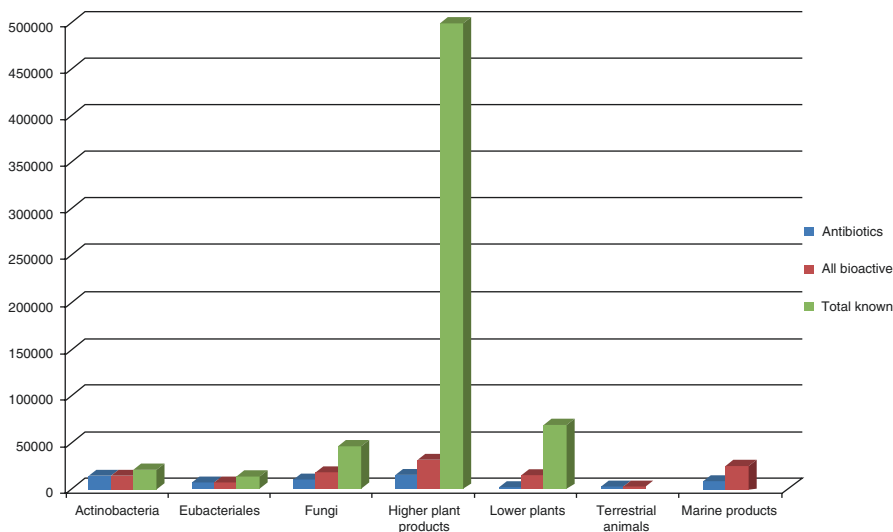
**Table 10.1** Color code of biotechnology

Color	Area of biotechnological activity and application
Red	Medicine, health and diagnostics
White	Industrial process and products
Green	Agriculture
Yellow	Nutrition, food and feed
Blue	Aquaculture, marine and coastal-related processes
Grey	Environmental issues
Gold	Bioinformatics and nanotechnology

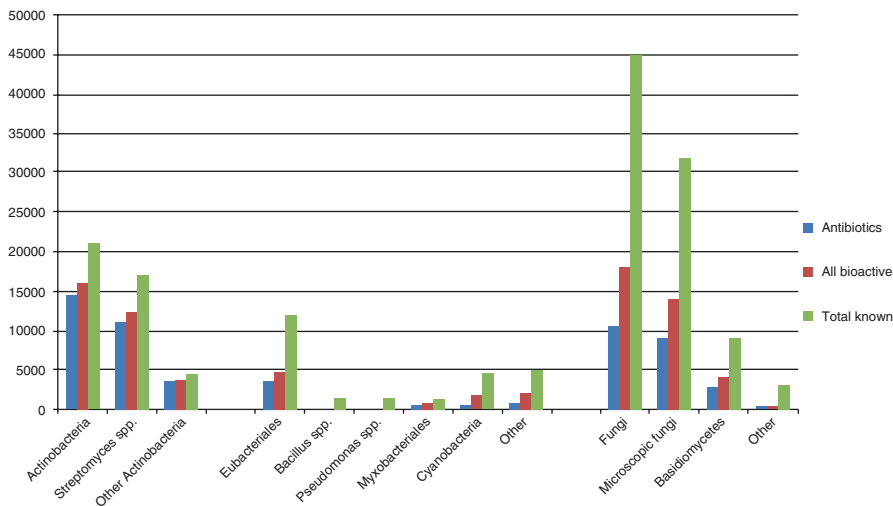
The role of actinobacteria in each of the fields mentioned in Table 10.1 is tremendous and the focus in this chapter.

## 10.2 Actinobacteria and Red Biotechnology

In the 1940s, the discovery of actinomycin and streptomycin in Selman Waksman's laboratory at Rutgers was the starting point for a unique role of microorganisms, the search on bioactive secondary metabolites within the actinobacteria with a special focus on antibiotics and their industrial use for many years. If we look to the number of known secondary metabolites from nature, actinobacteria are only one group of producers besides the majority of plant metabolites (Fig. 10.1). But if we look, on the other hand, on the number of antibiotics and other bioactive compounds, we can see that actinobacteria have a high potential; about 16,000 bioactive compounds from actinobacteria are known today, from which 14,500 are antibiotics (Fig. 10.2). Within the actinobacteria, *Streptomyces* is still the most potent genus with 12,400 known bioactive compounds (11,000 antibiotics); meanwhile from other actinobacteria, additional 3600 bioactive compounds (3400 antibiotics) are known. Many antibiotics from actinobacteria are used in medicine, but there are also many other indications where bioactive metabolites from actinobacteria are used commercially. For a comprehensive overview about the history of antibiotics research, see also (Luepke et al. 2017). In the next chapters, we will give an overview on the different groups of bioactive compounds with a focus on antibiotics which is related to the number of isolated compounds.



**Fig. 10.1** Number of natural products (data are based on Bérđy 2015)

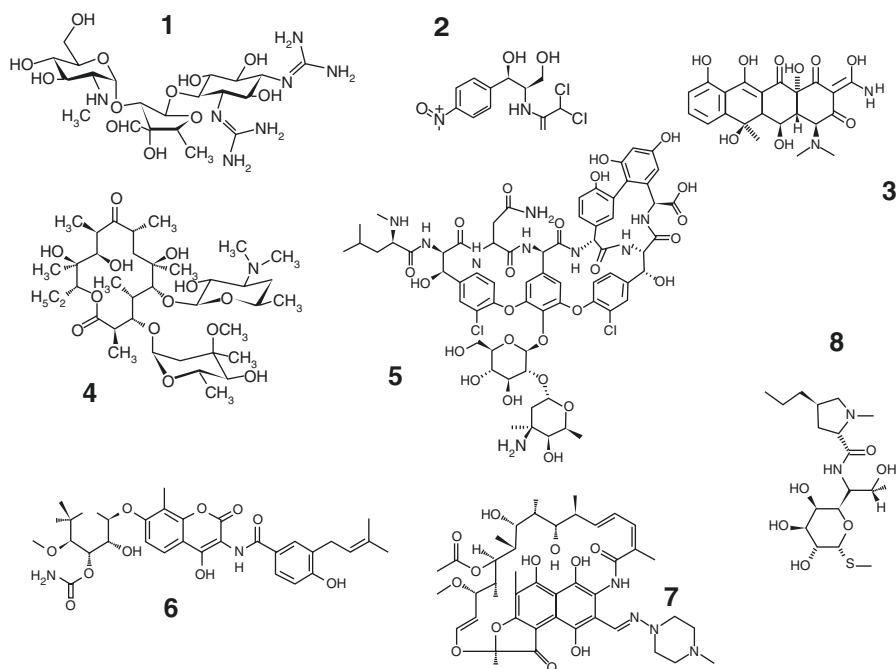


**Fig. 10.2** Number of natural products (data are based on Bérđy 2015)

## 10.2.1 Antibacterial Agents

### 10.2.1.1 The “Golden Era”

Today we know about 50,000 metabolites with antibiotic activity from natural origin, about 30,000 from microorganisms, including fungi (Bérđy 2015). From this huge number, about 190 are used therapeutically. From this, 130 are from microorganisms, mainly Actinobacteria, and are produced by fermentation.



**Fig. 10.3** Antibiotics from the “golden era.” 1 streptomycin, 2 chloramphenicol, 3 oxytetracycline, 4 erythromycin, 5 vancomycin, 6 lincomycin, 7 rifamycin, 8 novobiocin

Semisynthetic products are 55 and only 5 synthetic ones. The first antibiotic which still is on the market, the aminoglycoside *streptomycin*, was isolated in Selman Waksman’s laboratories (Fig. 10.3, 1). The producer of the compound is *Streptomyces anulatus* subsp. *griseus* (former *S. griseus*) and was published in 1944 by Schatz et al. Aminoglycosides like streptomycin are high potent broad-spectrum antibiotics. Aminoglycosides bind to the protein S12 in the 30S subunit of the ribosome and influence the binding of the formylmethionine tRNA to the ribosome which inhibits the correct initiation of the protein biosynthesis. Streptomycin is still in clinical use, it was the first antibiotic used against tuberculosis, and furthermore it showed activity against several other diseases that were not helped by penicillin. For the co-discovery of streptomycin, Waksman was awarded the Nobel Prize in 1952. Resistances against aminoglycosides are based on alteration of the ribosomal binding sites (streptomycin only), decreased uptake, and/or accumulation of the drug in bacteria and the bacterial expression of enzymes which modify the antibiotic and thereby inactivate it (Davies and Wright 1997; Mingeot-Leclercq et al. 1999).

From a culture of *Streptomyces venezuelae*, the antibiotic *chloramphenicol* (Fig. 10.3, 2) was isolated in the 1940s (Ehrlich et al. 1947, 1948). Gottlieb et al. (1948) described the broad-spectrum activity against Gram-positive and Gram-negative bacteria as well as anaerobes, spirochetes, rickettsiae, chlamydiae, and mycoplasma. Chloramphenicol binds reversibly to the 50S subunit of the ribosome where it suppresses the peptidyl transferase activity and inhibits the transfer of amino acids to the growing peptide chain. It was introduced to the market as chloromycetin in 1949 and was the first synthetically produced antibiotic (Rebstock et al. 1949).

*Streptomyces aureofaciens* and *S. rimosus* were the first described producers of antibiotics of the *tetracycline* group, namely, chlortetracycline (Duggar 1948) and oxytetracycline, respectively (Fig. 10.3, 3) (Finlay et al. 1950). Tetracyclines bind to receptors at the 30S subunit of the ribosome and inhibit the binding of the transfer RNA to the ribosomal complex. Therefore, new amino acids cannot elongate the polypeptide chain and the protein biosynthesis is interrupted. Tetracyclines are bacteriostatic and in high doses also bactericide. Most of the tetracycline resistance genes were found to be associated with plasmids, transposons, conjugative transposons, or integrons (Chopra and Roberts 2001), which leads to an increased probability of transfer between bacteria. Resistance genes code for enzymes which inactivate the drug, for efflux pumps or modification of the target at the ribosome (McMurry and Levy 2000). Even there are many resistant pathogens, tetracyclines are still of therapeutic interest especially after different semisynthetic approaches (Chopra and Roberts 2001). The structurally atypical broad-spectrum tetracycline, chelocardin, is produced by *Amycolatopsis sulphurea* (Mitscher et al. 1970; Oliver et al. 1962) and has recently become of scientific interest again due to its still unknown mode of action. Today compounds can be biosynthetically modified in order to optimize the pharmacological properties.

*Erythromycin* (Fig. 10.3, 4) produced by *Saccharopolyspora erythraea* (formerly *Streptomyces erythreus*) (McGuire et al. 1952) was the first macrolide compound which was developed to market as an antibiotic. Macrolides are macrocyclic polyketides which typically consist of a 12–16-member macrocyclic lactone with a glycosidic-linked amino sugar. Macrolides bind to the 23S ribosomal RNA in the 50S subunit of the ribosome. This binding inhibits the translocation of the protein biosynthesis. As most of the macrolides are very hydrophobic, the penetration through the outer membrane may be difficult. From this point many resistances arise. Further resistance mechanisms have been reported basing on target mutation or modification, a number of effective efflux pumps, and on plasmid coding esterases which inactivate the antibiotic (Leclercq 2002).

Glycopeptides were first isolated from cultures of members of the genus *Amycolatopsis* in the 1950s, which were mainly classified as *Nocardia* or *Streptomyces* species at that time. Glycopeptides are nonribosomal coded cyclic peptides which are glycosylated and in some cases also halogenated. *Vancomycin*

(Fig. 10.3, 5) was the first compound of this class and described as an antibiotic from *Streptomyces orientalis* (*Amycolatopsis orientalis*) by McCormick et al. (1954). The compound was isolated during a research program of Eli Lilly and came available for clinical use in 1958 (Jovetic et al. 2010). Mainly basing on the side effects it took until 1980 that vancomycin was used as an alternative antibiotic against multiresistant *Staphylococci*. Vancomycin is a third-line antibiotic which should only be used if other antibiotics show no effect basing on the resistance of the infecting bacteria. Glycopeptide antibiotics inhibit the bacterial cell wall biosynthesis by forming a complex with the terminal L-lysine-D-alanyl-D-alanyl groups of the cell wall element murein. So they block elements which are necessary for the cross-linking in the cell wall of Gram-positive bacteria basing on five glycine moieties (pentaglycine bridge). As a result, the necessary elements for the cross-linking (*N*-acetylglucosamine, *N*-acetylmuramic acid) cannot be fitted to the growing bacterial cell wall. Basing on the increasing osmotic pressure, cell walls without this cross-linking are destabilized. Resistance against glycopeptides is in most cases based on the expression of an alternative D-Ala/D-Ala ligase, which modifies the chain containing D-lactate at the N-terminus. Basing on this modification, the binding of the hydrogen bonds between the glycopeptide and the side chain is reduced to the factor 1000. Especially enterococci have established this type of resistance (Weigel 2003). Some bacteria also show natural intrinsic mechanisms of resistance against glycopeptides.

Another glycopeptide antibiotic, ristocetin (ristomycin), was first described by Grundy et al. (1955) from *Amycolatopsis lurida*. Today a number of glycopeptide antibiotics are known (Kahne et al. 2005) which can also be used as a taxonomic marker within the genus *Amycolatopsis* (Wink et al. 2004).

The producer of *lincomycin* (Fig. 10.3, 6) is *Streptomyces lincolnensis* which was isolated from a soil sample collected in Lincoln, Nebraska, in 1955 and later described by Mason et al. (1963). In the same year, the in vitro activity against Gram-positive bacteria was reported by Lewis. He found that the mode of action of lincomycin is very similar to those of macrolides. So both compound classes, even if they are chemically different (lincomycin contains propylproline, a derivative of proline, and the amino sugar methylthiolincosamide, a derivative of the C8 sugar octose), bind to the 50S subunit of the bacterial ribosome and inhibit the protein biosynthesis. The antibiotic is especially active against Gram-positive bacteria as staphylococci and streptococci and is used in the treatment of infections of the respiratory tract. The resistant mechanisms are similar to those of macrolides. Lincomycin belongs to the class of the lincosamides as well as the semisynthetic compound clindamycin, which is eight times more active (Meyers et al. 1969).

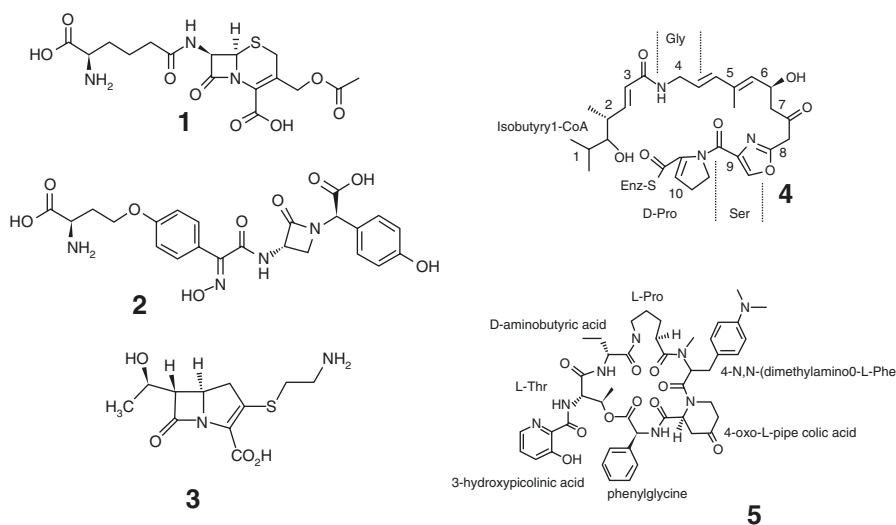
*Rifamycins* (Fig. 10.3, 7), substances of the ansamycin family, are antibiotics which are originally produced by members of the genus *Amycolatopsis* (Sensi et al. 1958; Wink et al. 2003). The first described rifamycin producer is a typical example of incorrect classification and renaming of antibiotic-producing actinobacteria at this time. Originally described as *Streptomyces mediterranei* (Margalith and Beretta 1960), the strain was later renamed *Nocardia mediterranei* and even later

*Amycolatopsis mediterranei* (Lechevalier et al. 1986). Rifamycin B, which chemical structure has been elucidated by Oppolzer et al. (1964), is the precursor of clinically used antibiotics. The mode of action of the ansamycins relies on the inhibition of the RNA syntheses by inhibiting the formation of the first phosphodiester bond in the RNA chain. They act at the  $\beta$ -subunit of the RNA polymerase and resistances can base on modification of this  $\beta$ -chain. The most important side effects of the ansamycins which are reported are a damage of the liver (hepatotoxic), a red orange color of body fluids basing on the compound color, and in some cases the red man syndrome. Due to these side effects, ansamycins were neglected as antibiotics for a long time. However, nowadays they became very important again in the treatment of mycobacteria like *Mycobacterium tuberculosis* and *M. leprae*. Also many semi-synthetic derivatives like rifamide, rifaximin, rifapentine, rifampicin, and rifabutin are on the market.

*Novobiocin* (Fig. 10.3, 8) is an aminocoumarin antibiotic which is also known as albamycin or cathomycin. The producing strain was originally described as *Streptomyces niveus* and has been reclassified as *S. sphaeroides* by Lanoot et al. (2002). The three chemical entities of an aminocoumarin are a benzoic acid derivative, a coumarin unit, and the sugar novobiocin (Heide 2014). Novobiocin is a potent inhibitor of the ATPase reaction which is catalyzed by the GyrB subunit of the DNA gyrase (Lewis et al. 1996). There is an overlapping of the binding sites of ATP and novobiocin at the binding sites of the gyrase molecule. Resistance to novobiocin results from modification of the enzyme, for example, exchanges of two amino acids in Gyr B of *Staphylococcus saprophyticus*: a glycine at position 85 and a lysine at position 140 (Vickers et al. 2007).

*Cephalosporins* are  $\beta$ -lactam antibiotics like penicillins and have been originally described as products from the fungus *Acremonium chrysogenum* (formerly *Cephalosporium acremonium*). In 1971, Nagarajan et al. from Eli Lilly reported the production of penicillin N and three derivatives of cephalosporin C as products from *Streptomyces* species. Higgins and Kästner from the same company described in the same year the producing strains as *Streptomyces clavuligerus* sp. nov. and *S. lipmanii* (Fig. 10.4, 1). These strains were also used for many studies of the production regulation (Aharonowitz and Demain 1978). Cephalosporins bind to the penicillin-binding proteins (PBPs) and inhibit the cell wall formation in proliferating bacteria. PBPs are enzymes in the inner wall of the bacterial cell membrane and are responsible for the structural integrity, the cell form, the cell division, the formation of capsule, the resistance to bacteriophages, and the regulation of autolysis. The  $\beta$ -lactam ring interacts with the PBPs and inhibits the synthesis of the cell wall. Most of the bacteria have four to eight PBPs. Resistance to  $\beta$ -lactams can occur by modification of the permeability of the outer membrane, modification of the PBPs, and also the production of  $\beta$ -lactamases.

Besides the cephalosporin type  $\beta$ -lactams, actinobacteria produce a wide variety of different compounds of this group, for instance, thienamycin (Fig. 10.4, 3), which was found as a product from *Streptomyces cattleya* in 1976 and described in 1979 from Merck Sharp and Dome (Kahan et al. 1979). This compound was the first naturally produced carbapenem antibiotic and is one of the most potent antibiotics



**Fig. 10.4** Antibiotics from the “golden era” II—1 cephalosporin C, 2 nocardicin, 3 thienamycin, 4 streptogramin A, 5 streptogramin B

showing high activity against Gram-positive and Gram-negative bacteria especially those which are resistant due to the production of  $\beta$ -lactamases. In the same year, Aoki et al. from Fujisawa published nocardicin (Fig. 10.3, 2), a monocyclic  $\beta$ -lactam from the fermentation of *Nocardia uniformis* subsp. *tsuyamanensis* (Hashimoto et al. 1976).

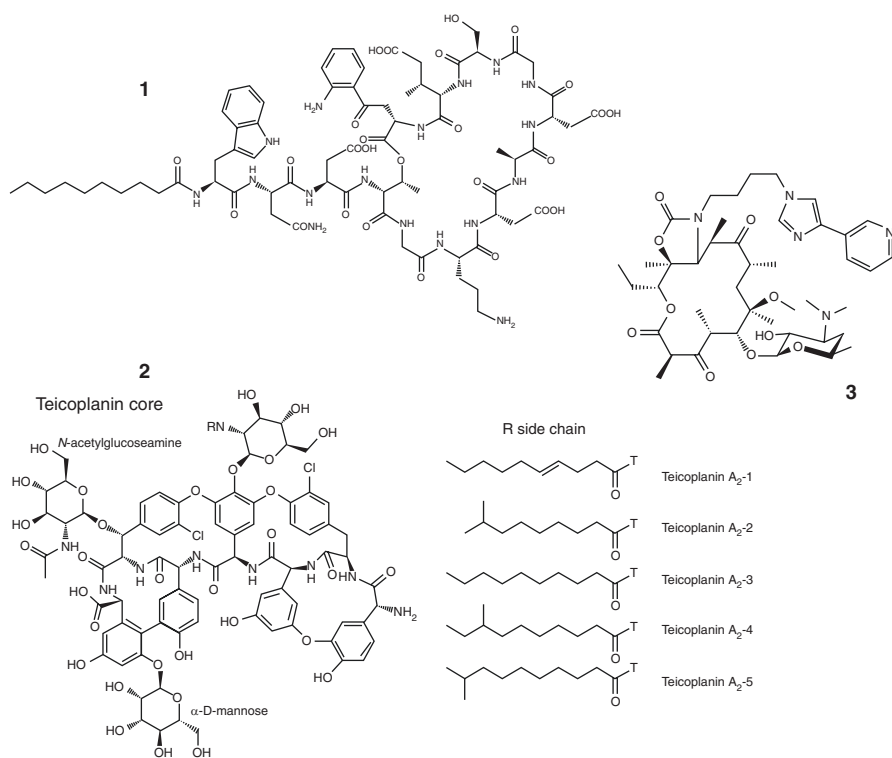
*Streptogramins* are the only described antibiotic class which is active by the synergistic effect of two structural nonrelated compounds. They are produced by *Streptomyces* and *Actinoplanes* species (Charney et al. 1953). Streptogramins came into interest as antibiotics basing on the upcoming resistance development in many pathogenic bacteria. Both subgroups bind at the P-domain of the 50S subunit at the ribosome and inhibit the elongation of the protein synthesis. The group A members of streptogramins are cyclic polyunsaturated macrolactones which contain peptide and polyketide elements (Fig. 10.4, 4). The group B members are branched cyclic hexa- or heptadepsipeptides (Khosla et al. 1999) (Fig. 10.4, 5). Given separately both compounds act bacteriostatically.

However, administered together they show bactericidal activity based on a synergistic effect due to a modified conformation at the 50S subunit. The binding of streptogramin A results in a 100-fold higher activity of streptogramin B. The first resistances have already been described shortly after the market launch and were based on a 23S-rRNA methylase which modifies the RNA molecule by methylation in a way that the interaction between antibiotic and ribosome is prevented. Some bacteria developed ABC transporters which are able to pump the streptogramins out of the cell actively. Today the streptogramins are only used for serious skin infections basing on streptococci and nosocomial lung infections caused by vancomycin-resistant enterococci.

### 10.2.1.2 The Next Generations

After a long period of starvation in antibiotic research, a group of novel lipopeptides was isolated from a culture of *Streptomyces roseosporus* and described in 1987 by Debono et al. from Eli Lilly. One of the lipopeptides was named daptomycin (Eisenstein et al. 2010) (Fig. 10.5, 1) and was developed later as an antibiotic by Cubist. Daptomycin has a bactericidal effect by integrating calcium dependent into the cell membrane of Gram-positive bacteria where the drug assumes the function of an ion channel. Once fixed into the membrane, the lipopeptide forms pores which lead to an efflux of potassium ions, resulting in a depolarization of the membrane potential. As a result, the bacterial DNA, RNA, and protein synthesis are influenced (LaPlante and Rybak 2004). Daptomycin is actually one of the most potent antibiotics on the market and is used for treatment of serious infections with Gram-positive pathogens like methicillin-resistant *Staphylococcus aureus* (MRSA) which became resistant against second-line antibiotics like vancomycin. As daptomycin is a relatively new antibiotic on the market up to now, only a few cases of resistances have been reported. Some *Staphylococcus aureus* strains have developed a regulatory adoption of the cell membrane and wall by mutation, resulting in resistance.

*Teicoplanin* (Fig. 10.5, 2) is a glycopeptide antibiotic which has originally been described as a product of *Actinoplanes teichomyeticus* (Wink et al. 2006;



**Fig. 10.5** The next-generation antibiotics. 1 daptomycin, 2 teicoplanin, 3 Ketec



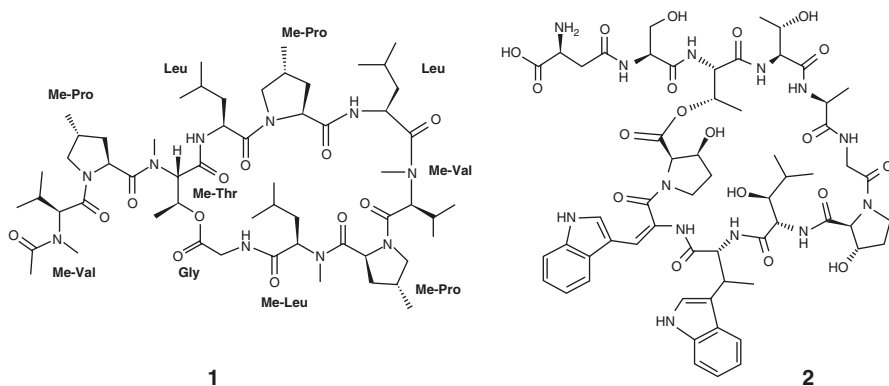
Somma et al. 1984). This compound has been marketed by Sanofi-Aventis under the trade name Targocid as a mixture of several compounds (teicoplanin A2-1 to A2-5 and RS-1 to RS-4). The core structure of all components is identical, but they can be distinguished according to different side chains and the glycosylation. Like other glycopeptides, teicoplanin targets the peptidoglycan synthesis. As an effective antibiotic against Gram-positive bacteria including methicillin-resistant *Staphylococcus aureus* and *Enterococcus faecalis* strains, Targocid is used in the treatment of such serious infections. Actually three new lipoglycopeptides, i.e., telavancin, dalbavancin, and oritavancin, have been registered for the treatment of infections with *S. aureus*, including MRSA (Hestekamp 2015).

Hoechst Marion Roussel (later Sanofi-Aventis) developed the semisynthetic erythromycin derivative *telithromycin*, brand name Ketek (Fig. 10.5, 3), which has been modified by substitution of a keto group for the cladinose sugar, addition of a carbamate ring in the lactone ring, and attachment of an alkyl-aryl moiety to this carbamate ring (Scheinfeld 2003). To achieve better acid stability, the carbon at position 6 has been methylated as is the case in clarithromycin (Griesgraber et al. 1996). Telithromycin was introduced onto the market between 2001 (Europe) and 2004 (United States). Like the classical macrolides, telithromycin interferes with the protein synthesis by binding to the 50S subunit of the ribosome. The affinity of telithromycin is approximately ten times higher than that of erythromycin. Furthermore, telithromycin binds simultaneously to two domains of 23S RNA of the 50S subunit, while the classical macrolides only bind to one (Zhanel et al. 2002).

### 10.2.1.3 Oldie Approach

In recent years, some companies, which are still focused on antibiotic research, started so-called oldie approaches. Many antibiotics were found, isolated and tested during the golden era of antibiotics between 1940 and 1970 (Luepke et al. 2017). However, their development has temporarily been suspended at that time, because the compounds could not be chemically modified in order to increase solubility/stability or they did not fit any longer into the companies' portfolio at that time. Some forgotten antibiotics which induced resistance in unproblematic bacterial strains or agents of previously neglected disease (e.g., many tropical infection diseases) has currently come back into focus.

In early screening programs for antibacterials at Rhone Poulenc, France, a strong activity in the culture extract of a *Streptomyces* isolate was detected. This strain was described in detail in a patent (Mancy et al. 1973), but the description remained incomplete and the name was never validated. This active substance, later called *griselimycin* (Fig. 10.5, 1) (Terlain and Thomas 1971), came again back into focus of research in the beginning of the twenty-first century due to its specific activity on mycolic acid-containing Gram-positive bacteria. In the meantime, both the identification and characterization of the biosynthesis gene cluster of griselimycin and methylgriselimycin (Broenstrup et al. 2012) and further taxonomic studies of the strain have been published (Wink et al. 2017). It was shown that new optimized derivatives of griselimycin inhibit the DNA polymerase sliding clamp DnaN of *M. tuberculosis*, both in vitro and in vivo (Kling et al. 2015).



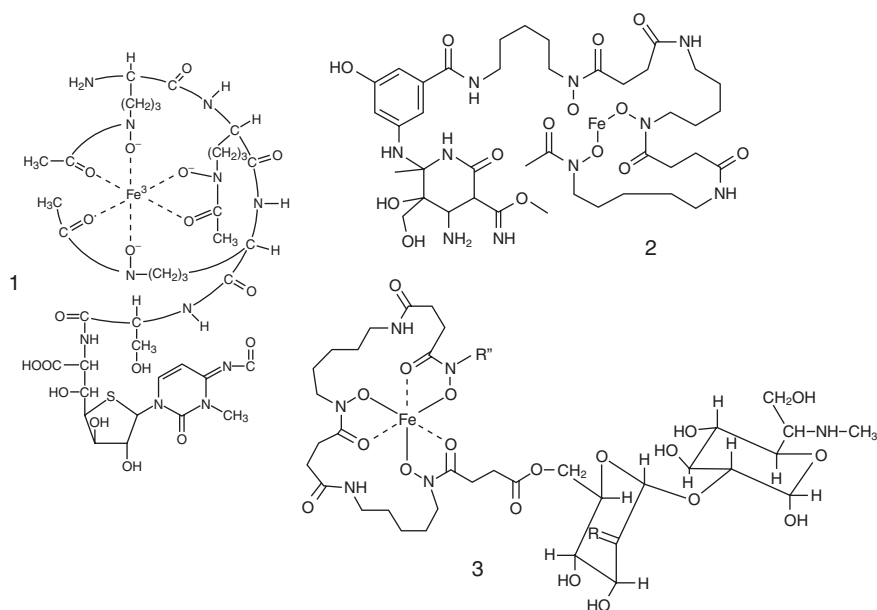
**Fig. 10.6** Antibiotics from the “oldie approach.” 1 griselimycin, 2 telomycin

*Telomycin* (Fig. 10.6, 2), depsipeptide antibiotic, was isolated by Bristol-Meyers Company in the 1950s, and the structure was published in 1967 by Sheehan et al. The compound was described as highly active against Gram-positive pathogens, but due to undesirable site effects, the further development has been stopped. The compound project was then revealed by scientists at Sanofi-Aventis. During fermentation studies, they could identify a number of precursors of telomycin, which in turn showed enhanced activity against Gram-positive bacteria (Fu et al. 2015). Due to its novel mode of action, telomycin lacks the cross resistance with several clinically important antibiotics. One of these compounds displays a strong activity against vancomycin-resistant enterococci (VRE).

#### 10.2.1.4 Siderophores

Siderophores are a group of typical secondary metabolites from microorganisms especially produced by Actinobacteria. As their biological activity is caused by forming chelates with metal ions like iron, they also show toxic side effects. New strategies in antibiotic research brought these compounds back into interest (Nagoba and Vedpathak 2011). On one hand, siderophores are used as “Trojan horses” as transporters through the cell membrane by coupling them with antibiotics (Möllmann et al. 2009), and on the other hand they can be coupled to anticlinins which act as transport vehicle to the pathogens within the patient (Gebauer and Skerra 2009; Schlehuber and Skerra 2005).

*Albomycin* (Fig. 10.7, 1) is an iron chelator which was first described by the Russian group of Gause and Brazhnikova (1951). They described the producer as *Actinomyces subtropicus* and the compound as a reddish, iron-containing peptide. Although albomycin was found to be active against Gram-positive cocci and Gram-negative bacteria and was also classified as nontoxic, a clinical application failed because of high resistance development to the antibiotic (Gause 1955). Another main problem was the low productivity of the producer strain. In 1985 the group of Hans Zähner described a further producing strain of albomycin belonging to the species *Streptomyces griseus* (Fiedler et al. 1985). Later studies showed that the active part of albomycin is a potent seryl-tRNA synthetase inhibitor (Stefanska



**Fig. 10.7** Siderophores. 1 albomycin, 2 ferrimycin, 3 salmycin

et al. 2000) and that this effective antibiotic also shows activity against problem causing germs like *Yersinia enterocolitica* and *Streptococcus pneumoniae* (Pramanik et al. 2007). Similar to albomycin are the *ferrimycins* (Fig. 10.7, 2) which have been reported by Bickel et al. (1960, 1966). The ferrimycins are active against Gram-positive bacteria by altering the protein biosynthesis. They are produced by *Streptomyces* species, e.g., *Streptomyces griseoflavus*.

Another iron chelator is *salmycin* (Fig. 10.7, 3) a product from *Streptomyces violaceus* (Vértesy et al. 1995). Salmycin has a siderophore moiety and an aminoglycoside moiety which are responsible for the antibiotic uptake in the bacterial cell and antibacterial activity, respectively.

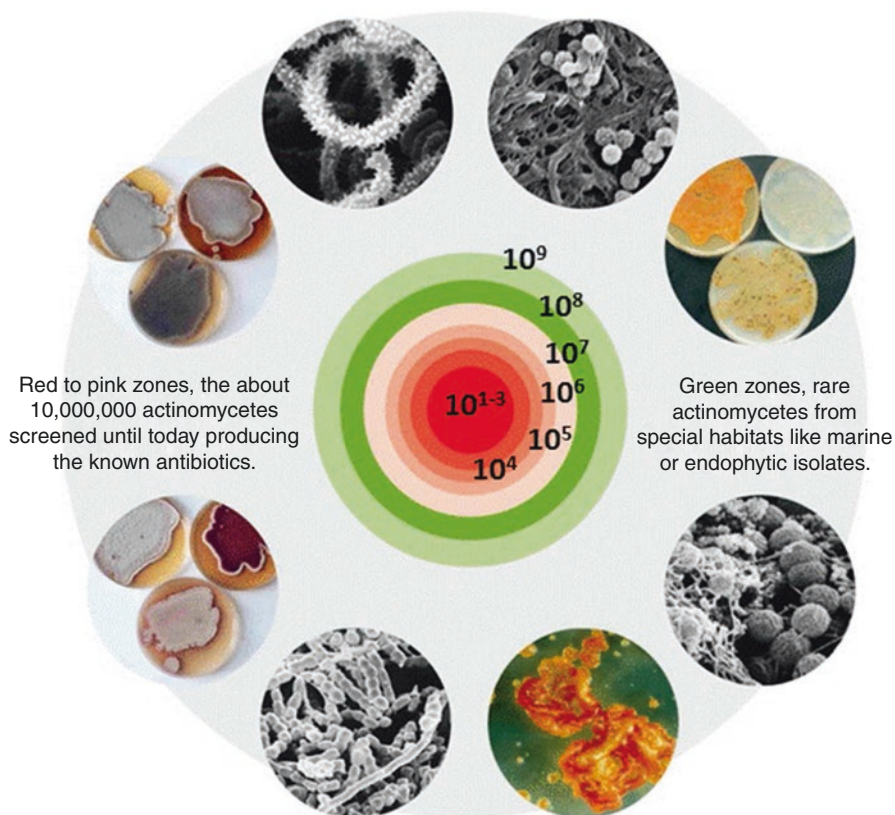
### 10.2.1.5 Conclusion and Outlook

After the golden era of antibiotics, many companies dropped their screening programs for antibiotics. As a result, we have a lack in the antibiotic pipeline today, although new therapeutics are urgently needed because of the rising number of resistant pathogenic bacteria (especially in hospitals) and the rising role of the neglected diseases, e.g., tuberculosis, tropical viruses, and so on. So the question rises whether actinobacteria are still a worthwhile source for novel antibiotics. This has been discussed by many authors during the last years. Baltz (2007), for example, pointed out the following problems/suggestions:

- Today only a small number of resources have been analyzed for actinobacteria, and many genera and species are waiting for their isolation.

- Actinobacteria are the producers of complex antibiotics, which can be modified by the use of combinatorial biosynthesis.
- The analysis of the actinobacteria genome sequences will lead us to many novel antimicrobial agents.

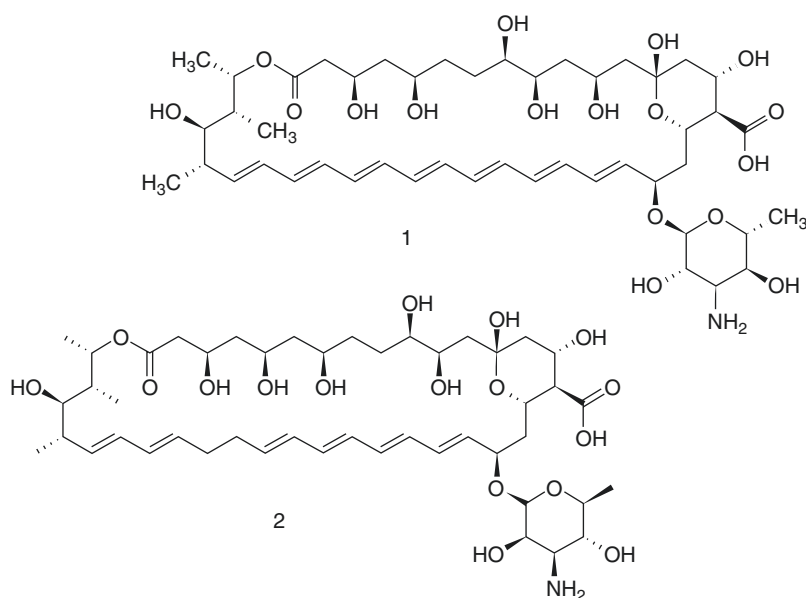
The selection of rare actinomycetes and strains from uncommon habitats will enrich the chance for novel antibiotics, so that we do not have to screen millions of extracts (see Fig. 10.7; Baltz 2006). With the access to biodiversity, development of new isolation methods, use of miniaturized screening approaches, high-throughput generation screening of extracts, and highly sophisticated screening approaches will lead us to new antibiotics in the future as well (Genilloud et al. 2011). Besides, biodiversity attention will focus more and more on the issue of using the genome potential (Müller and Wink 2014). Bode et al. (2002) showed that also with classical methods like variation of media or physical parameters, the production of secondary metabolites in actinobacteria can be influenced/increased so that novel compounds could be isolated (Fig. 10.8).



**Fig. 10.8** For the isolation of novel antibiotics, we should screen “rare” Actinobacteria and those from special habitats to avoid the screening of millions of extracts (based on Baltz 2006 and Müller and Wink 2014)

## 10.2.2 Antifungal Agents

Under the current antifungal therapeutics, only one class of compounds produced by actinobacteria plays an important role: the polyene macrolactones (Tanaka 1992). Nevertheless, today *amphotericin B* (Fig. 10.9, 1) is the only known compound available for systemic use against fungal infections. Amphotericin was described by Trejo and Bennett (1963) as a product of *Streptomyces nodosus*. The biosynthesis and biological properties were published by Gold et al. (Donovick et al. 1954). The drug in particular was used against infections caused by *Cryptococcus* and *zygomycetes* as well as against *Histoplasma* and blastomycosis. The polyenic compound interacts with the cell membrane building block ergosterol. Ergosterol is a component of the fungal and mycoplasma cell membrane but absent in mammals. Based on this interaction, the permeability of the membrane for potassium ions is increasing and the cell becomes leaky. On the other hand, the compound binds not selectively to ergosterol but also to the human stearines and from this results the toxicity of the compound. Today amphotericin B is mainly used for topical treatment of skin infections. To avoid side effects caused by intravenous use, amphotericin B is combined with liposomes or other lipid formulations. In addition to amphotericin B, *nystatin* is another antifungal polyenic compound which is already in clinical use. This drug was first described by Hazen and Brown (1950) and is produced by *Streptomyces noursei*. The strain was named after the family Nourse from whose garden soil the bacterium was isolated. The mode of action is similar to those of amphotericin B, and to date no resistances against these compounds were observed. Nystatin is mainly used prophylactically by immunosuppressed people with high risk for fungal infections like AIDS patients or cancer



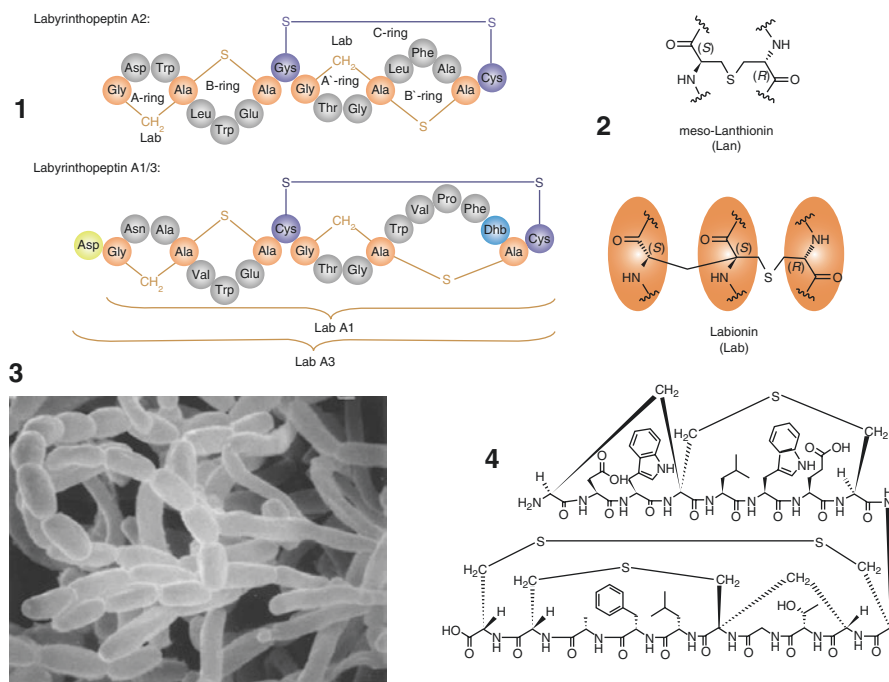
**Fig. 10.9** Antifungals. 1 amphotericin B, 2 nystatin

patients receiving chemotherapy. Nystatin is also widely used as antifungal in microbiological laboratories.

There were many approaches to develop special cell wall biosynthesis inhibitors as antifungals. Most of them are products of fungi like the candins, a group of glucan synthesis inhibitors. Some sphingolipid biosynthesis inhibitors have been found in the extracts of some actinobacteria (*Streptomyces* and *Micromonospora*) like rustmicin and galbonolide, two macrolides without any sugar moiety (Vicente et al. 2003).

### 10.2.3 Antiviral Agents: The Labyrinthopeptin Story

A number of antibiotics produced by Actinobacteria also show activity against viruses, like kanamycin and hygromycin against orthomyxoviruses, novobiocin and daunomycin against herpes viruses, and pepstatin, amphotericin, and doxorubicin against retroviruses (HIV). Anyway these substances are unimportant for the clinical treatment of viral infections (Takeshima 1992). Until today the chemically synthesized compound acyclovir in addition to some dideoxynucleotide analogues are the most important ones. In the last years, a new group of lantibiotics produced by an *Actinomadura* species comes more and more into focus of research as antiviral compounds. As these compounds have a special history which reflects the nonlinear way of compound development in pharmaceutical companies, this will be reported here (Fig. 10.10).



**Fig. 10.10** The labyrinthopeptins. 1 amino acid chain and sulfur bridges of the labyrinthopeptins, 2 structure of labionin, 3 spore chains of *Actinomadura namibiensis*, 4 structure of Labyrinthopeptin A2

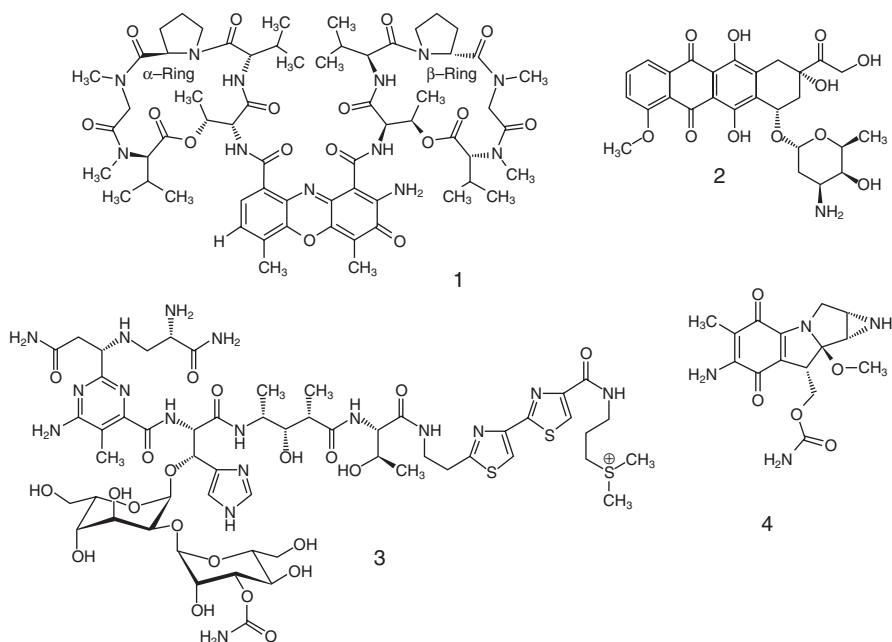
The story began in 1988, when a salmon-pink actinobacterium of the neglected groups was isolated from a soil sample collected in the Namib Desert, Namibia. The strain was screened in several programs, and a weak activity against influenza, herpesviruses, and adenoviruses was found. The active compounds were isolated and characterized as novel peptides. As this activity was not in a range of interest and the structure elucidation was not easy, the company dropped the project. Some years later, the strain was identified to be a novel species within the genus *Actinomadura* and was described as *Actinomadura namibiensis* from Wink et al. (2003). Remembering the novel peptidic structure cooperation with the group of Prof. Süssmuth was started. This group could identify the compounds as a novel class within the lantibiotics containing the novel amino acid labionin with a special sulfur bridge formation (Meindl et al. 2010). Before publishing the structure, the activity and structure were patented by the company Sanofi-Aventis in 2008. The strain produces three different *labyrinthopeptins*, whereby labyrinthopeptins A1 and A3 are the products of one structural gene and labyrinthopeptin A2 derives from a second. The company follows the pain killer activity against pain of labyrinthopeptin A2 for the next years but dropped it again mainly on the solubility. In between, a strong antiviral activity of labyrinthopeptin A1 against HIV and HSV was found (Féir et al. 2013). This activity in addition to further activities against other viruses is responsible that labyrinthopeptin or its derivatives are on intensive development and may get the first antiviral product from actinobacteria.

## 10.2.4 Antitumor Agents

### 10.2.4.1 Cytostatics

Actinomycin was the first substance isolated in initial screening programs in Waksman's lab in 1940. The producing microorganism of this polypeptide antibiotic is *Streptomyces antibioticus* subsp. *antibioticus* (formerly *Actinomyces antibioticus*) (Waksman and Woodruff 1940). As the compound was too toxic, it could not be used in antibacterial therapy in humans, even the compound showed interesting activity against a broad range of bacteria including tuberculosis (Waksman and Woodruff 1941). *Actinomycin D* (Fig. 10.11, 1) a product of *Streptomyces parvulus* was also the first antibiotic with anticancer activity and is still in use in antitumor therapy. The compound intercalates with the DNA and inhibits the opening of the double helix. In lower dosages, actinomycin D is an inhibitor of the DNA-dependent RNA synthesis by intercalation with the guanine nucleotides of the DNA. For the intercalation, the asymmetric phenoxazinone plays an important role because it binds selectively to the guanine- and cytosine-rich areas of the DNA. This binding at the DNA blocks the RNA polymerase. Actinomycin D is as Lyovac-Cosmegen® from MSD as cancer therapeutic on the market. Based on its mode of action, actinomycin has also become an important tool in molecular and cell biology (Hollstein 1974).

The anthracyclines (Brockmann and Niemeyer 1968) are a family of anticancer therapeutics. *Daunomycin* (Di Marco et al. 1964) and *Adriamycin* (Arcamone et al. 1969) are the best known ones (Fig. 10.11, 2). The compounds are products of



**Fig. 10.11** Tumor therapeutics from Actinobacteria: 1 actinomycin, 2 daunomycin, 3 bleomycin, 4 mitomycin

different species of the genus *Streptomyces*. *Streptomyces peucetius* (Grein et al. 1963), for example, is the producer of daunorubicin, one of the glycosylated anthracyclines. The mode of action is basing on the intercalation with the DNA. The DNA synthesis is influenced and topoisomerase II is inhibited. Cytostatic drugs of this group are used in the tumor treatment especially in mammary carcinoma, bronchial carcinoma, and lymphoma (Fujiwara et al. 1985).

*Streptomyces verticillus* (formerly *Streptoverticillium*) is the producer of the glycopeptide antibiotic *bleomycin* (Fig. 10.11, 3) and was first published by Umezawa et al. (1966). The therapeutic is a mixture of the two naturally occurring derivatives of bleomycin A2 and B2 (Takita et al. 1972). Bleomycin forms a complex with binary metal ions, mainly Fe (II). This complex is oxidized by a reactive oxygen type and is activated. This active complex leads to a radical reaction of a nucleotide in the small furrow of the DNA resulting in a DNA strand break and fragmentation of the DNA (Galm et al. 2005). The biosynthesis of bleomycin is a hybrid between polyketide and nonribosomal peptide biosynthesis (Shen et al. 1999).

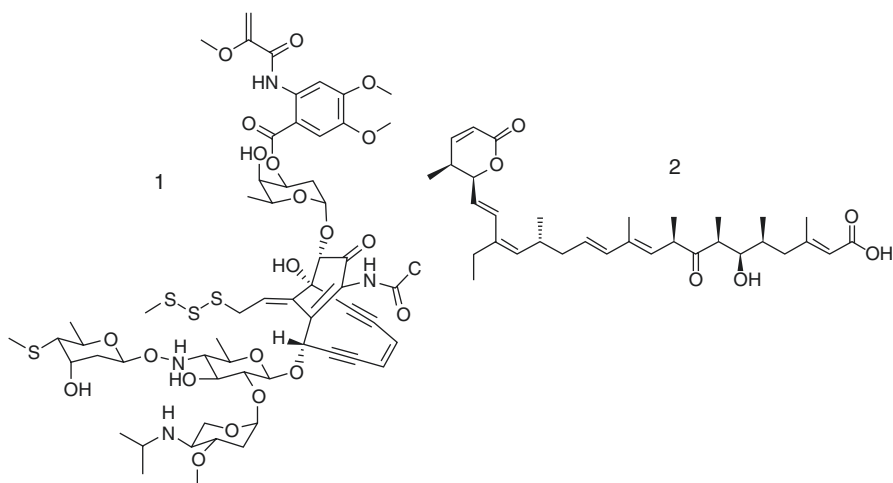
In 1956 *mitomycin C* (Fig. 10.11, 4) was isolated as an antibiotic from *Streptomyces caespitosus* (Hata et al. 1956). The compound is active against bacteria, viruses, and cancer cell lines and is nowadays used as a cytostatic agent. Mitomycin C intercalates between two strands of the DNA, leading to a covalent binding between these strands and preventing the dissociation, which is necessary for replication or transcription of the DNA. The irreparable damages at the DNA lead to cell apoptosis (Galm et al. 2005).



### 10.2.4.2 Toxins for Immunoconjugates

Highly toxic compounds are coming back into the interest of pharmaceutical companies as anticancer therapeutics basing on the technique to combine the toxins with specific antibodies. The toxin-carrying antibodies bind to an antigen on the target cell, the immunotoxin enters the cell, and the active compound (toxin) kills the tumor (Galm et al. 2005).

The endiine class of cytostatics or antibiotics is one of the most important in this category (Fig. 10.12, 1). *Esperamicins* and *calicheamicins* are the most popular compound groups. The detection and structure elucidation took place at two different companies at almost the same time. Esperamicins were products from Bristol Myers and the calicheamicins from American Cyanamid Company. The producer of the esperamicins is an *Actinomadura verrucosospora* strain, whereas calicheamicins are products of *Micromonospora echinospora*. Both compound groups were published in the same journal in the same year as a follow-up of a number of articles (Golik et al. 1987; Lee et al. 1987). The description of the strain taxonomy and additional natural compounds followed in the subsequent years (Lee et al. 1989; Maiese et al. 1989). The characteristic of the endiine (or enediyne) is an unsaturated core with two acetylenic groups that are conjugated to a double bond. The endiine structural moiety can react with the DNA, and by the formation of diradicals, the double strand can be damaged or broken. These damages are responsible for the cytotoxic effect of the endiines. They are very potent cell toxins with an activity which is about 1000-fold higher than in adriamycin. Within the calicheamicins, there are members that contain bromine and others that contain iodine; the latter were detected by adding sodium iodide to the fermentation broth, which leads to new compounds in much higher yields (Lee et al. 1989; Nicolaou and Dai 1991).

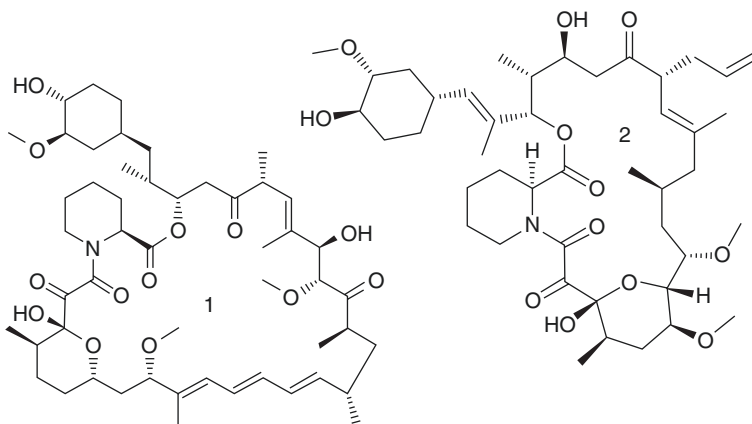


**Fig. 10.12** Toxins. 1 Enedis, 2 leptomycin

A second example for a high toxic compound that will be used in immunoconjugates is *leptomycin* (Fig. 10.12, 2). This compound was originally identified as an antifungal antibiotic produced by a *Streptomyces canosus* strain (Hamamoto et al. 1983). The antifungal activity of leptomycin was observed against *Schizosaccharomyces pombe* where it causes cell elongation and against *Mucor* strains where the substance causes hyphal swelling. Afterward, the effect in mammal cells was found, where leptomycin causes G1 cell cycle arrest. The mode of action of leptomycin B is the alkylation and inhibition of chromosomal region maintenance (CRMI). This protein is needed for the nuclear export of proteins (Kudo et al. 1998, 1999; Nishi et al. 1994). Therefore, leptomycin B is a potent cell cycle blocker.

### 10.2.5 Immunosuppressive Agents

Two macrolactone macrolides play an important role as immunosuppressant agents. Both are produced by *Streptomyces* species, and both show some structural homology but have different modes of action. The first is *rapamycin* (Fig. 10.13, 1) or sirolimus, a product of *Streptomyces rapamycinicus* (Kumar and Goodfellow 2008) which was originally described as *Streptomyces hygroscopicus* by Vezina et al. (1975). The strain was isolated from a soil sample collected on the Easter Island Rapa Nui. The compound was detected due to its antifungal activity, and the structure was described by Sehgal et al. (1975). The mode of action of rapamycin bases on inhibition of some cytokine connected signal transduction pathways by forming a complex with the protein mTOR (mammalian target of rapamycin), which is a serine/threonine kinase with a size of 282 kDa. As a result, the following activation and protein biosynthesis of the S6 kinase (p70SK6) is not possible, and the activation of the ribosomal protein S6 fails. The inhibition of mTOR inhibits the activation of the p34cdc2 kinase and therefore the complex formation with cyclin E. This results in the inhibition of activation as well as the transfer of the T-cells from the G1 phase to the S-phase in the cell cycle. Rapamycin is used together with



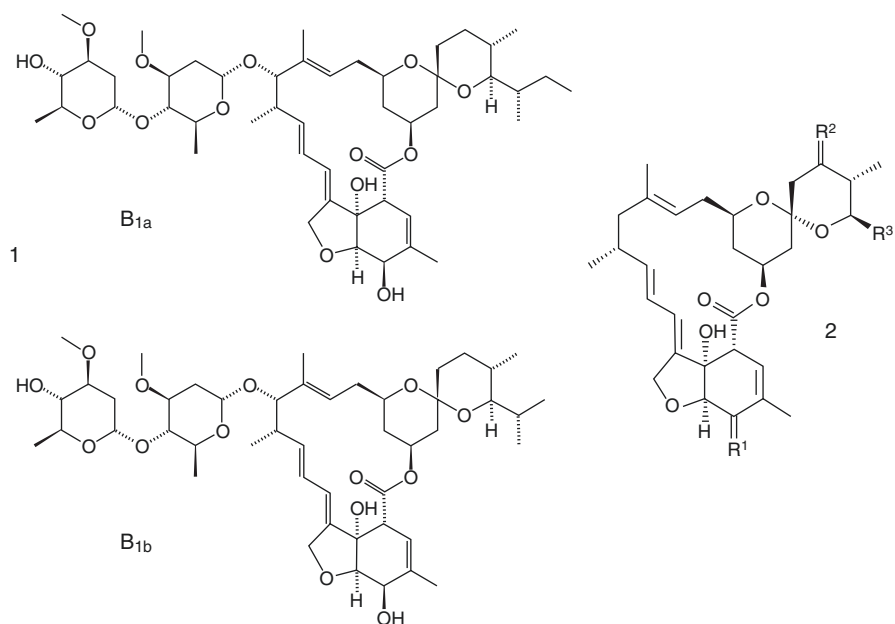
**Fig. 10.13** Immunomodulators. 1 Rapamycin, 2 FK 506

ciclosporin and some corticosteroids for suppression of the organ rejection after transplantations. Rapamycin could also be isolated from other actinobacteria like *Actinoplanes*, a species that also produces a number of analogues by microbial manipulation (Nishida et al. 1995).

The second macrolactone macrolide is *FK 506* (Fig. 10.13, 2), also called tacrolimus. This compound was described by Kino et al. (1987) as a fermentation product of *Streptomyces tsukubaensis* detected during a screening for inhibitors of IL-2 production. The in vitro immunosuppressive effect was described by the same author in the same year. Tacrolimus belongs to the group of the calcineurin inhibitors. The compound acts specific in the signal transduction and activation of T-cells. It binds to a cytosolic receptor, an immunophilin (FKBP12), within the target cell. The complex which is formed by the immunophilin and tacrolimus binds to the serine-threonine phosphatase calcineurin which now cannot be activated anymore. Basing on this the transcription and release of some cytokines (especially IL-2 but also c-myc, IL-3, TNF $\alpha$ , IFN- $\gamma$ ) in the T-cells is inhibited. As a result, the reaction of the immune system on the transplanted organ is inhibited. The mode of action of tacrolimus is more similar to that of ciclosporine than to that of sirolimus.

### 10.2.6 Antiparasite Agents

The *avermectins* (Fig. 10.14, 1) and the *milbemycins* (Fig. 10.14, 2) are two groups of 16-membered macrolactones from different *Streptomyces* species which



**Fig. 10.14** Antiparasites from actinobacteria: 1 avermectins, 2 milbemycin

show potent anthelmintic and insecticidal activities. Especially the avermectins came into public interest, when Satoshi Omura was awarded together with William C. Campbell the Nobel Prize for Medicine in 2015 (“the derivatives of which have radically lowered the incidence of river blindness and lymphatic filariasis, as well as showing efficacy against an expanding number of other parasitic diseases”). That was a clear signal for the upcoming role of the “neglected diseases” and their treatment.

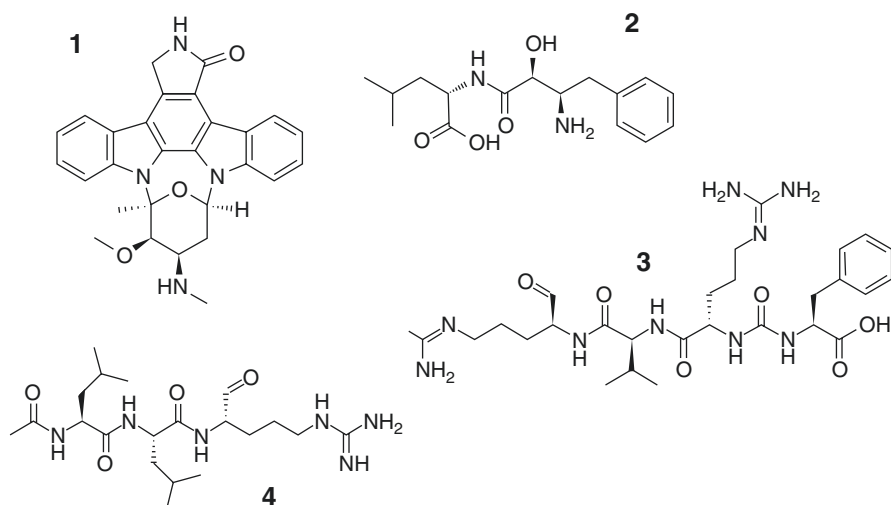
The history goes back to 1978, when the avermectin producer strain was isolated at the Kitasato Institute in Tokyo. In the same year, the strain was given to the laboratories of Merck Sharp and Dome for testing, and the anthelmintic activity was detected. In 1979, the researchers of this group described the avermectins as a new family of potent anthelmintic agents (Burg et al. 1979; Miller et al. 1979). The avermectins act at the invertebrate-specific glutamate-gated chloride channel by enhancing the effect of glutamate to this. As a result, the transmission of electrical activity in the nerve and muscle cells of the invertebrates is blocked (Bloomquist 1996, 2003). These compounds are not toxic for mammals, because they do not possess such ion channels (Bloomquist 1993). The proposed name of the producer *Streptomyces avermitilis* was validated by Kim and Goodfellow and also renamed by Takahashi from Kitasato Institute to *Streptomyces avermectinius*, both in 2002 (Kim and Goodfellow 2002; Takahashi et al. 2002).

The second group is the milbemycins, aglyca of the avermectins, and also 16-ring macrolide. They were first described by Takiguchi et al. (1980) as fermentation products of a *Streptomyces* strain. The taxonomy of the producing organism and some mutants followed 3 years later (Okazaki et al. 1983). Today 13 natural milbemycins are known. One is milbemycin oxim, a product of *Streptomyces hygroscopicus* subsp. *aureolacrimosus*. It enlarges the membrane permeability in invertebrate nerves or muscle cells for sodium ions by binding at glutamate- and GABA-activated channels. The result is a hyperpolarization of the cell membrane and a blocking of the activation transfer. The therapeutic use is much smaller than in the avermectins.

## 10.2.7 Enzyme Inhibitors

### 10.2.7.1 Enzyme Inhibitors: Products from Satoshi Omura’s and Hamano Umezawa’s Groups

*Staurosporine* (Fig. 10.15, 1) is one of the best-known enzyme inhibitors from actinobacteria. The compound was found by Satoshi Omura and coworkers in the culture of a *Streptomyces* isolate in 1977. Although the compound is not in clinical use, there were many approaches in this direction, and Omura called it “a potentially important gift from a microorganism” (Omura et al. 1995). The main activity is the inhibition of protein kinase, which results from the prevention of ATP binding to the kinase. The selectivity is low so that many protein kinases are inhibited. This is also the main reason why staurosporine did not yet reach the clinical phase. Omura described a number of different biological



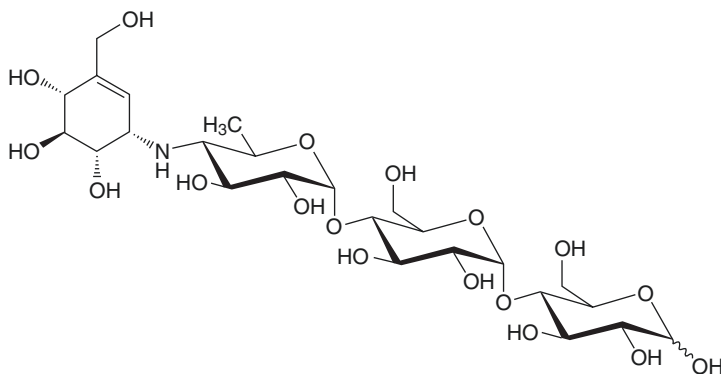
**Fig. 10.15** Enzyme inhibitors. 1 staurosporine, 2 bestatin, 3 leupeptin, 4 antipain

activities of staurosporine, like relaxation of smooth muscle, inhibition of platelet aggregation, neurotropic activity, blocking of cell cycle, antitumor activity, and activity against hyperplastic cell growth. The development over the last years suggests that the encapsulation in liposome nanoparticle might be a new way for a therapeutic use of staurosporine as an anticancer product (Mukthavaram et al. 2013).

The group of Hamano Umezawa in Tokyo has specialized on the screening of enzyme inhibitors from Actinobacteria for many years. Three examples which are well known and used in biochemistry but have not reached clinical use are the protease inhibitors *bestatin* (Ubimex/Fig. 10.15, 2) from *Streptomyces olivoreticuli* (Umezawa et al. 1976); *leupeptin* (Fig. 10.15, 3) from *Streptomyces roseus*, *S. roseochromogenes*, *S. chartreuse*, *S. albireticuli*, *S. thioluteus*, *S. lavendulae*, and *S. noboritoensis* (Aoyagi et al. 1969); and *antipain* (Fig. 10.15, 4) from a nonspecified *Streptomyces* (Umezawa et al. 1972).

### 10.2.7.2 $\alpha$ -Glucosidase Inhibitor Acarbose

*Acarbose* is a pseudotetrasaccharide and is used as an oral antidiabetic agent. Together with a number of structural-related pseudo-oligosaccharides, the compound is produced by a strain of the genus *Actinoplanes* (Müller et al. 1980). *Acarbose* is an inhibitor of the  $\alpha$ -glucosidase, an enzyme which catalyzes the hydrolysis of oligo-, tri-, and disaccharides to glucose in the gut. As a result, the blood sugar level after a meal is reduced (Müller 1989; Truscheit et al. 1981). Basing on this *acarbose* is used for treatment of diabetes mellitus type 2 and is sold by Bayer under the trade name *Glucobay* (Fig. 10.16).



**Fig. 10.16** Structure of acarbose

### 10.3 Actinobacteria and White Biotechnology

Converting living organisms into bio-factories for the sustainable production of a variety of materials using renewable sources is the goal of white or industrial biotechnology. The importance of industrial biotechnology is majorly due to its independency to traditional petrochemical feedstock with where “white” is referring to the positive environmental aspects linked to the application of industrial biotechnology. Other than environmental and ecological benefits, products of white biotechnology display better performance in comparison with chemical-based productions in terms of reaction rate and efficiency, purity of the final product, as well as the better energy consumption profile and lower chemical waste generation. Hence, white biotechnology has been widely accepting and is efficiently penetrated in all sectors of industrial productions (Soetaert and Vandamme 2006). The field integrates the application of different disciplines including microbiology, biochemistry, and molecular genetics as well as process technology and design. Here, the use of microbial cells and their biocatalysts has been greatly developed and efficient. In this section, the wide potentials of actinobacterial members in the field of white biotechnology are reviewed.

#### 10.3.1 Enzymes

More than 50% of the industrial enzymes are obtained from bacteria within which there is a wide array of enzymes derived from various genera of actinobacteria. Since these microorganisms are one of the ubiquitous dominant groups of bacteria, they are able to produce various kinds of extracellular enzymes which can decompose different materials. On the other hand, their enzymes have been proved to be more attractive than enzymes from other sources due to their higher stability and

substrate specificity reported by many studies (Jaouadi et al. 2010; Nawani et al. 2002; Zhang et al. 2011).

According to the results obtained from BRENDA database which is a comprehensive enzyme information system (Schomburg et al. 2002), more than 66,900 enzymes have been found today from actinobacteria among which there are several industrially important enzymes within which the most notable examples are discussed below.

### 10.3.1.1 Proteases

Hydrolases are the largest group of commercially applicable enzymes and are often of great demand. Among the hydrolases, microbial proteases (EC 3:4, 11–19, 20–24, 99) occupy an important platform and have been extensively studied (Nigam 2013). Depending on their catalytic pH optima, these enzymes are classified as acidic, neutral, or alkaline protease among which alkaline and neutral proteases own an important commercial share due to their use in detergent, leather tanning, silk, and food industry. Microbial alkaline proteases are accounting for more than 65% share of the mentioned industries, thus dominating the world enzyme market (Mienda et al. 2014). Although *Bacillus* spp. are the major producers of these enzymes industrially, actinobacteria show good promises. Alkaline proteases are majorly produced by *Streptomyces* spp. among actinobacteria. On the other hand, proteases obtained from *Nocardioopsis* spp. are being mostly employed as detergent additives as well as for depilation in leather industry (Moreira et al. 2002). Most importantly, a large variety of alkaliphile or alkalitolerant actinobacteria produces alkalistable proteases. Alkalistable proteases are potent candidates in industry since they are also thermostable and resistant in the presence of many organic solvents. Most recently there have been potent commercially relevant alkalistable proteases discovered from *Saccharomonospora viridis* SJ-21 whose optimum temperature and pH is 70 °C and 9, respectively (Jani et al. 2012), as well as a protease from *Nocardioopsis prasina* HA-4 with the mentioned factors being 55 °C and 7–10, respectively (Ningthoujam et al. 2009). Table 10.2 demonstrates the most important actinobacteria used in industrially relevant production of proteases.

Efforts in finding novel potent proteases are increasingly continued within actinobacterial species, and promising candidates are being screened and introduced to further enter the relevant industrial procedure (Gohel and Singh 2015; Rohamare et al. 2015; Touioui et al. 2015; Xin et al. 2015).

**Table 10.2** Major protease-producing actinobacteria

Organism	Important properties of the produced enzyme	Reference
<i>Arthrobacter protophormiae</i>	Broad range of optimum pH 11–12, high isoelectric point	Takegawa et al. (1993)
<i>Brevibacterium linens</i>	Stable over a pH range from 6 to 10, optimum pH 8	Juhász and Škárka (1990)
<i>Microbacterium</i> sp.	Stable over the pH range of 5–12, Ca <sup>2+</sup> required for enzyme activity, and stability in over 50 °C	Gessesse and Gashe (1997)
<i>Nocardiopsis dassonvillei</i>	Stable in the range of pH 4–8, optimum temperature 70 °C	Tsujibo et al. (1990)
<i>Nocardiopsis</i> sp.	Stable in the presence of oxidants and surfactants, active after 30 min in 80 °C	Moreira et al. (2002)
<i>Pimelobacter</i> sp. 2483	Optimum pH and temperature for the hydrolysis of casein 9 and 50 °C, respectively	Oyama et al. (1997)
<i>Streptomyces microflavus</i>	Neutral protease	Rifaat et al. (2005)
<i>Thermomonospora fusca</i>	Activity from 35 to 95 °C	Gusek and Kinsella (1987)

### 10.3.1.2 Amylases

Amylases are another group of main enzymes used in industry which hydrolyze the starch molecules into polymers composed of glucose units. These enzymes are produced by various organisms; however, microbial amylases have dominated the industrial sectors (Souza 2010). Amylases are widely used in pulp and paper, textile, laundry detergents, baking, brewing, juice industries, and generally in any starch processing industrial procedure with occupying 25% of the global enzyme markets. The genera *Nocardia* and *Streptomyces* display amyolytic activity when cultivated on media with maltose; therefore, the presence of these enzymes in actinobacteria is a well-known phenomenon (Mordarski et al. 1969). Table 10.3 shows the most important industrially viable amylases from actinobacteria. *S. erumpens* produces thermophilic and acidophilic amylases which can find applications in bakery, brewing, and alcohol industries. *Nocardiopsis* sp. also produces thermostable amylases with applications in paper and bakery industries. *S. hygrosopicus* and *S. praecox* are two actinobacteria which are being commercially used for the preparation of high maltose syrups to date.



**Table 10.3** Industrially important actinobacterial amylase producers

Organism	Important properties of the produced enzyme	Reference
<i>Streptomyces hygroscopicus</i>	Converts starch to maltose in 75% yield	McKillop et al. (1986)
<i>Streptomyces limosus</i>	Unstable above 45 °C but at 25 °C efficiently attacks raw starch granules	Fairbairn et al. (1986)
<i>Streptomyces praecox</i>	Converts maltotriose without appreciable formation of glucose	Suganuma et al. (1980)
<i>Streptomyces erumpens</i>	Thermostable	Kar and Ray (2008)
<i>Nocardiopsis</i> sp.	100% of residual activity at 70 °C	Stamford et al. (2001)
<i>Thermomonospora curvata</i>	Does not accumulate products repressive to cellulase production during growth on starch/cellulose ratios	Stutzenberger and Carnell (1977)
<i>Thermobifida fusca</i>	Maltotriose producing	Yang and Liu (2004, 2007)

### 10.3.1.3 Xylanases

Xylanase which hydrolases xylan, the second most abundant polysaccharide in nature, has the potential applications in food and feed industries for the production of D-xylose (an artificial sweetener), paper and pulp industries, as well as in biofuel production process from agricultural biomass (Dodd and Cann 2009; Viikari et al. 2007).

Microbial xylanases occur in the form of extracellular complexes like cellulases, and they comprise endo- and exo-xylanases which are different in substrate specificity. Mesophilic actinobacteria produce the endo-type xylanases among which many are found in *Streptomyces* spp. (Kluepfel et al. 1986; Marui et al. 1985; Nakajima et al. 1984). Most of the xylanases explored exhibit their optimum activity at 40–60 °C, and there are few thermophilic actinobacteria studied for the production of heat-resistant xylanases. *Thermomonospora* sp. is of the studied actinobacterial members producing thermostable xylanase whose optimum temperature is 60–70 °C and at pH from 5.0 to 8.0. Apart from being industrially relevant for food and feed industry, these enzymes are great candidates for biodegradation of hemicelluloses and xylanases as burden biomass (Vaijayanthi et al. 2016). Although there are an increasing number of xylanases discovered from actinobacteria, the commercially relevant xylanase producers from Actinobacteria phylum are *Thermomonospora fusca* used in paper and pulp industry (McCarthy et al. 1985), *Streptomyces* sp. Ab106 (McCarthy et al. 1985), and *Kocuria* sp. RM1 which is applicable in animal feed industry (Krishna et al. 2008).

### 10.3.1.4 Cellulases

Cellulases are produced by a large diversity of bacteria and fungi, and their synthesis is induced during their growth on cellulosic materials. These enzymes are classified into three main groups, endo-(1,4)- $\beta$ -D-glucanase (EC 3.2.1.4), exo-(1,4)- $\beta$ -D-glucanase (EC 3.2.1.91), and  $\beta$ -glucosidases (EC 3.2.1.21), which

**Table 10.4** Actinobacterial producers of cellulases

Organism	Important properties of the produced enzyme	Reference
<i>Thermomonospora</i> spp.	Thermostable proteases, produces in high titer	Ferchak and Pye (1980), Moreira et al. (1981), and Stutzenberger (1972)
<i>Streptomyces antibioticus</i>	Endo-cellulase, acts on carboxymethylcellulose	Enger and Sleeper (1965)
<i>Streptomyces flavogriseus</i>	Induced by xylan, effectively hydrolyze acid-swollen cellulose	Kluepfel and Ishaque (1982)
<i>Thermobifida fusca</i>	Efficient in degrading apple peel	Kim et al. (2005)
<i>Acidothermus cellulolyticus</i>	Thermostable	Mohagheghi et al. (1986)
<i>Streptomyces transformant</i> T3-1	Thermostable cellulase whose activity is stable at 50 °C for more than 7 days	Jang and Chen (2003)

differently catalyze the substrate, thus producing different products. Accordingly, exo-glucanase catalyzes at the ends of the cellulose chain and the end product would be  $\beta$ -cellobiose, while endo-glucanase produces glucan chains via random catalysis of glycosidic bonds. The latter group of cellulases or the  $\beta$ -glycosidases produces glucose with their substrates being specifically  $\beta$ -cellobiose disaccharides (Kuhad et al. 2011). Cellulases possess various applications in different industries such as being used in cellulose-based detergents, improved fabric quality and removal of excess dye from fabrics in textile industry, conversion of cellulosic materials to ethanol, and production of energy-rich animal feed in fermentation and bioconversion industry as well as its use in pulp and paper industry as co-additive for bleaching (Kuhad et al. 2011). Therefore, the increasing demand for cellulase production to be used in different industries requires an efficient and non-expensive strategy for which microbial resources are great candidates (Karmakar and Ray 2011).

Members of several mesophilic and thermophilic actinobacteria have been studied for their ability to degrade cellulose (Table 10.4). The cellulases of *T. fusca* and *Acidothermus cellulolyticus* have extensively been studied and are being used in bioethanol production from plant cell components (Kim et al. 2005; Mielenz 2001). *Streptomyces transformant* T3-1 is another thermostable cellulose producer whose enzyme is shown to be stable at 50 °C for more than 7 days and is one of the most industrially important cellulases within actinobacterial members (Jang and Chen 2003).

### 10.3.1.5 Other Enzymes

There is an array of other industrially important enzyme being produced by actinobacteria including laccases, dextranases, lipases, etc., which are potentially implemented in different industries. However, the production of these enzymes by actinobacteria is to some extent less studied in comparison to the previously described enzymes. Data on these enzymes are collected in Table 10.5.

**Table 10.5** Industrially important miscellaneous enzymes from actinobacteria

Enzyme	Producer organism	Application	Reference
Keratinase	<i>Thermomonospora curvata</i>	Pharmaceutical	Stutzenberger (1971)
	<i>Actinomadura keratinolytica</i> Cpt29	Leather industry	Habbeche et al. (2014)
Dextranase	<i>Streptomyces</i> sp. NK458	White sugar production	Purushe et al. (2012)
Laccase	<i>Thermobifida fusca</i>	Waste and textile dye treatment, hair coloring	Chen et al. (2013)
	<i>Streptomyces</i> sp. SB086	Waste and textile dye treatment	Fernandes et al. (2014)
Lipase	<i>Streptomyces rimosus</i> R6-554W	Thermostable lipase	Abramić et al. (1999)
	<i>Streptomyces lavendulae</i>	Cholesterol esterase used in clinical tests	Kamei et al. (1979)
	<i>Rhodococcus (Nocardia) erythropolis</i>	Cholesterol esterase used in clinical tests	Kurane et al. (1984)
Chitinase	<i>Streptomyces griseus</i>	Fungal cell wall degradation, utilization of chitin wastes	Kurane et al. (1984)
	<i>Streptomyces orientalis</i>	Fungal cell wall degradation	Tominaga and Tsujisaka (1976)
Pectinase	<i>Streptomyces lydicus</i>	Beverage and textile industry	Jacob et al. (2008)

### 10.3.2 Organic Acids

Although not the first microorganism of choice for industrial production of organic acids, *Corynebacterium glutamicum* as a prominent member of actinobacteria is reported to be able to produce some types of organic acids such as lactic acid, succinic acid, and acetic acid from glucose in mineral medium under oxygen deprivation (Inui et al. 2004). Consequently, Okino et al. introduced a new bioprocess for organic acid production implementing *C. glutamicum*. They have shown that organic acid production of bacterium under oxygen deprivation was more efficient than conventional fermentations in terms of volumetric productivity and dispensability of complex nutrients thus being promising for further use in larger scales (Okino et al. 2005). On the other hand, propionic acid is the by-product of cobalamin production by *Propionibacterium shermanii* and *Propionibacterium freudenreichii* that is crucial for efficient production of this vitamin as it acts as a neutralizer (Martens et al. 2002). However, it seems that by using in situ separation method for propionic acid removal, organic acid can be kept as the second product.

Generally, *Streptomyces* are reported to acidify the medium to a small degree anility of which is varying depending on the source of their isolation and low pH tolerance. Therefore, the search for organic acid production in these bacteria seems reasonable. Accordingly, *Streptomyces* have been reported to be capable of producing pyruvic, alpha-ketoglutaric, lactic, and succinic acid. However, this production

is inherently not industrially relevant in terms of yield, and further studies can be performed to optimize the production of such acids.

Although actinobacterial organic acids have not been yet entered commercially relevant phases, they could be good candidates due to their specific metabolic and physiological traits and can be improved for organic acid production via modern technologies such as in situ downstream processing, synthetic biology, or metabolic engineering if elucidated to be useful.

### 10.3.3 Microbial Biotransformation

Chemical reaction catalyzed by microbial cells or enzymes isolated from them is called biotransformation. The strategy is generally used for yielding metabolites with novel structure and function as in pharmaceutical research to discover or design new drugs (Pervaiz et al. 2013) as well as in bioremediation where hazardous compounds can be transformed to their nontoxic derivatives (Díaz 2008).

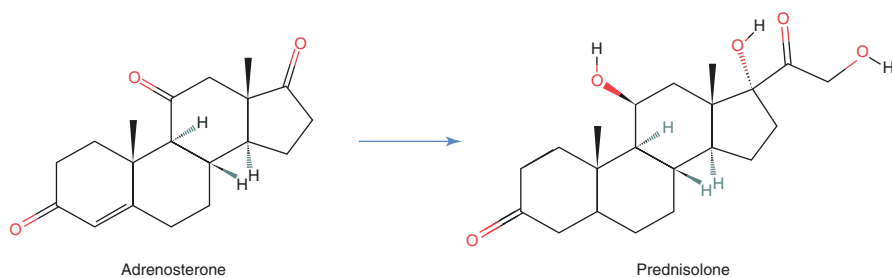
One of the industrially relevant biotransformation procedures is the transformation of nitrile compounds. Nitriles ( $RC \equiv N$ ) can be produced whether naturally (through anaerobic degradation of amino acids or by cyanogenic plants) or synthesized chemically. These compounds have various uses in the manufacturing process of glue and rubber. Furthermore, reduction of nitrile compounds provides a range of commercially important chemicals. However, they are thought to be persistent toxic materials in the environment which should be converted into nonhazardous compounds (Velankar et al. 2010). Biotransformation of nitrile compounds is performed via whole cells, cell extracts, and isolated enzymes in which members of actinobacteria show promises (Velankar et al. 2010). Enzymes used for the procedure are mesophilic or thermophilic nitrilases and nitrile hydrolase/amidases sourced from different bacteria including actinobacteria as well as fungi. *Arthrobacter nitroguajacolicus* (Shen et al. 2009), *Streptomyces* sp. (Nigam et al. 2009), *Rhodococcus ruber* (Zhang et al. 2009), *Nocardia* (Bhalla and Kumar 2005), and *Nitriliruptor alkaliphilus* ANL-iso2 (Sorokin et al. 2009) are of most important examples of actinobacterial producers of these enzymes which are reported to be potent in biotransformation of nitrile compounds in industry.

Synthesis of steroid hormones is another procedure being preferably performed via microbial transformation. Steroids are clinically used in different medical segments such as endocrinology, oncology, rheumatology, gynecology, etc. The production of different steroid-based drugs and hormones is currently being performed via combination of microbial biotransformation and chemical synthesis. Accordingly, many members of actinobacteria are capable of biotransforming steroid core to different derivatives. These reactions include dehydrogenation, double bond isomerization, oxidation of steroid alcohols, as well as double bond hydrogenation, hydroxylation, etc. (Donova 2007). Here, the ability to dehydrogenate C-C bonds within the steroid nucleus is a distinct feature of actinobacteria. Actinobacterial genera such as *Streptomyces*, *Actinoplanes*, *Corynebacterium*, *Arthrobacter*,

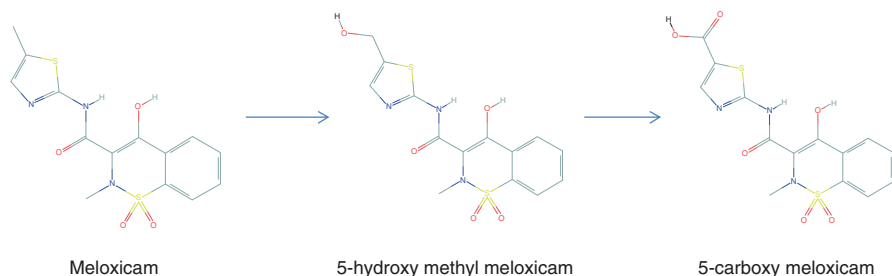
*Micromonospora*, *Nocardia*, *Rhodococcus*, *Gordonia neofelifaecis* (Liu et al. 2011), and *Mycobacterium* are known to be capable of effecting the mentioned diverse types of steroid transformation (Donova 2007; Donova and Egorova 2012). More importantly, microbiological 1(2)-dehydrogenation of 3-ketosteroids by actinobacterial species such as *Arthrobacter simplex* (Sebek and Perlman 1979) has been for more than 30 years, the base of technologies for manufacturing androsta-1,4-dien-3,17-dione (ADD) such as prednisolone (a corticosteroid) (Fig. 10.17) in pharmaceutical industry due to the high level of 3-ketosteroid-1(2)-dehydrogenase in these bacteria (Luthra et al. 2015).

As another example, *Streptomyces griseus* is reported by Gurram et al. to be capable of biotransforming meloxicam to 5-hydroxymethyl meloxicam in a higher yield and 5-carboxy meloxicam in trace amounts (Fig. 10.18) (Gurram et al. 2009). Meloxicam is a nonsteroidal anti-inflammatory drug (NSAID) developed for the treatment of rheumatoid arthritis and osteoarthritis which is sold in more than 30 countries worldwide. The pharmacokinetic and pharmacodynamics of the biotransformed products of this drug are found to be enhanced and thus can be promising drug candidates whose development is in progress (Pervaiz et al. 2013).

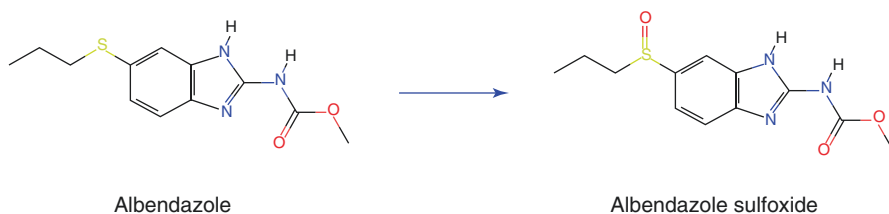
To better elucidate the actinobacteria's potential in biotransforming drug compounds, *Streptomyces griseus* can also transform albendazole (an antiparasitic compound) to albendazole sulfoxide (possess greater solubility in comparison to albendazole) (Prasad et al. 2010) (Fig. 10.19).



**Fig. 10.17** Chemical structure of prednisolone biotransformed from adrenosterone using actinobacterial potential



**Fig. 10.18** Biotransformation of meloxicam to its derivatives by *Streptomyces griseus*



**Fig. 10.19** Chemical structure of albendazole and its more water-soluble derivative

### 10.3.4 Biofuel

Currently there is an immense interest in biofuel research due to the great energy demand and increase in global fossil fuel prices. In the first-generation biofuel production, food crops such as sugar and wheat are the feedstocks. Since in this strategy food crops are being used while the lack of food is a serious global challenge, the second generation comes to address the problem where non-food crops such as wood and organic waste were studied for their potentials in biofuel production. Microorganisms are being vastly implemented in this research area for the production of different kinds of biofuels such as ethanol, hydrogen, biogas, and biodiesel from cheap and abundant raw materials such as cellulose, xylan, lignocellulose, and generally nonedible carbohydrates which are considered to as bioburdens (Elshahed 2010). Accordingly, as mentioned in Sect. 10.2.1, many actinobacterial species are potent in degrading cellulosic and hemicellulosic biomass (as burden biomasses) and therefore are candidates in an economic biofuel industry.

As an industrially performed process, in 2013, Actinogen announced an increase of up to 37% in ethanol production from glycerol. The research confirmed that Actinogen's system, which is based on actinomycetes from Western Australian soil samples, produces cellulases for conversion of cellulose to ethanol (Ltd 2013). In a more recent study, Hardter et al. have used genetically modified *Streptomyces coelicolor* A3 harboring synthetic genes *adhB* and *pdc* encoding an alcohol dehydrogenase and a pyruvate decarboxylase, for ethanol production up to 2.6 g/L, respectively (Hardter et al. 2012). *Streptomyces* was chosen because it has the capacity to withstand relatively low pH; high temperature; high sugar, salt, and ethanol concentrations; and other various harsh conditions, which could be used to develop an advanced biocatalyst and improve the commercial competitiveness of fuel ethanol production (Hardter et al. 2012). Moreover, a novel strategy is recently shown to be the implementation of microbial oils as feedstocks for biodiesel production which may be produced by yeast, fungi, and also actinobacteria. Although the study is its infancy, it has great promises in biofuel industry (Saraf and Hastings 2010). Actinobacteria can be indirectly used for similar strategy where their lipases can be used for the optimization of natural oils used for biodiesel production (Purushothaman 2015).

It should be noted that recently, biofuel production based on algal and cyanobacterial biomass has been also attracted attentions due to the fact that these organisms can use CO<sub>2</sub> as their carbon source and thus reduce the concerning amount of this

greenhouse gas from the atmosphere while at the same time being implemented as biofuel producing organisms, thus representing a promising future. On the other hand, actinobacteria with their astonishing catalytic potentials can be efficiently implemented to use the carbohydrate bioburden on the planet (containing mainly lignocellulose) which is produced  $150\text{--}170 \times 10^9$  tons annually (Hadar 2013) as their carbon source while using their metabolic potential for biofuel production.

---

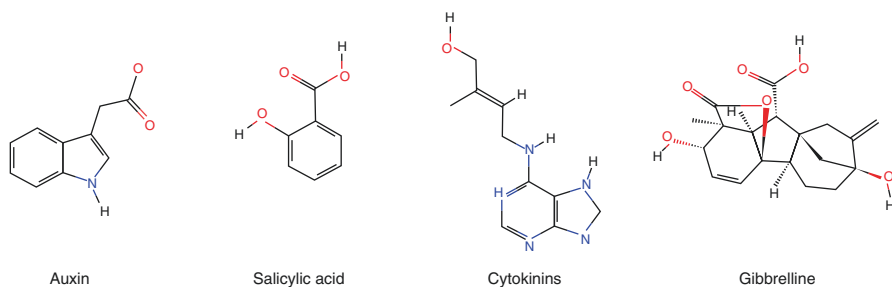
## 10.4 Actinobacteria and Green Biotechnology

The rising need for food supply due to the ever-increasing world population demands an efficient and sustainable agricultural productivity. Biotechnological innovations have been expanded widely to this area and have shown great promises. From genetically modified crops to strategies for optimizing the yield and quality traits of agricultural productions, green biotechnology is efficiently contributing. In general, there are three approaches in green biotechnology including the increasing of crop yield and growth control of unwanted plants, improving the tolerance of crops to abiotic stresses, and implementing plants as factories for the production of useful metabolites.

The role of microorganisms in achieving a sustainable agriculture is considerable due to the fact that there is a genetic dependency of plants on the beneficial functions provided by symbiotic cohabitants such as bacteria and fungi. Moreover, microorganisms are shown to significantly affect plant fitness and soil quality, thereby increasing the productivity of agriculture and stability of soil (Hamedi and Mohammadipanah 2015). Hence, the rational implementations of such potentials can be a good step in agricultural biotechnology. Since actinobacteria are distributed vastly in different environments such as soil and in association with plants, their application is also promising.

### 10.4.1 Biocontrol

Actinobacteria are widely distributed in association with plant in natural environments either as symbionts or parasites (Hamedi and Mohammadipanah 2015; Okazaki et al. 1995). These so-called endophytic bacteria usually give some physiological and environmental advantages to their host plants such as producing enzymes able to degrade the virulence factors of phytopathogens as well as increasing the drought, radiation, or heavy metal resistance of plants by regulating the biosynthesis of specific phytohormones (Hamedi and Mohammadipanah 2015). Among these advantages is that they sometimes make the host plants a kind of resistance to the plant's pathogens. Therefore, they can be rationally used as biocontrol agents. Being more predominantly investigated among actinobacteria, *Streptomyces* spp., isolated from the rhizosphere, are believed to be a very promising group of biocontrol agents of many plant pathogens whose functionality is mainly thought to be due to its antibiosis and degradation of phytotoxins



**Fig. 10.20** Structure of common phytohormones produced or modulated by symbiont actinobacteria

(El-Tarabily and Sivasithamparam 2006; Okazaki et al. 1995; Sabaratnam and Traquair 2002; Xiao et al. 2002). A comprehensive review of these actinobacteria can be studied in the study of Shimizu (2011). Examples of non-streptomycete actinobacteria are also reported for their use in biocontrol which include *Actinoplanes* spp. against *Pythium* damping-off (Khan et al. 1997) and *Microbispora* sp. against *Gaeumannomyces graminis* var. *tritici* in wheat (Coombs et al. 2004). Several actinobacteria produce phytohormones or modulate such hormones in plants. Members of the genera *Micromonospora*, *Streptomyces*, *Actinoplanes*, and *Frankia* are reported to produce or modulate the production of auxin, salicylic acid, cytokinins, and gibberellins, respectively (Fig. 10.20) (Hirsch and Valdés 2010; Lin et al. 2012; Scherlach and Hertweck 2009; Solans et al. 2011).

There are a number of commercially used products based on these plant growth-promoting actinobacteria in agriculture such as Actino-Iron<sup>®</sup> which contains *Streptomyces lydicus* strain WYEC 108 as an active fungicide ingredient, thus being used as a biocontrol commercial agent (Crawford et al. 2005).

Other than the role of actinobacteria in producing or modulating the phytohormones, many of them produce antimicrobial agents which can be used to fight against plant pathogens, many of which are commercially available. For instance, Plantomycin<sup>®</sup> which is bactericidal combination of actinobacterial antibiotics (mainly streptomycin from *Streptomyces griseus*) is being commercially used for the control of bacterial diseases in plants. Other examples are Kasumin<sup>™</sup>, Bio-Mycin, and Omycin which are kasugamycins from *Streptomyces kasugaensis* and act as antibacterial and antifungals for plant diseases. PH-D<sup>®</sup> Fungicide is also an antifungal product based on Polyoxin D from *Streptomyces cacaoi* var. *asoensis* which is also commercially available. More actinobacterial products used in biocontrol of crops can be found in Hamedi and Mohammadipanah (2015).

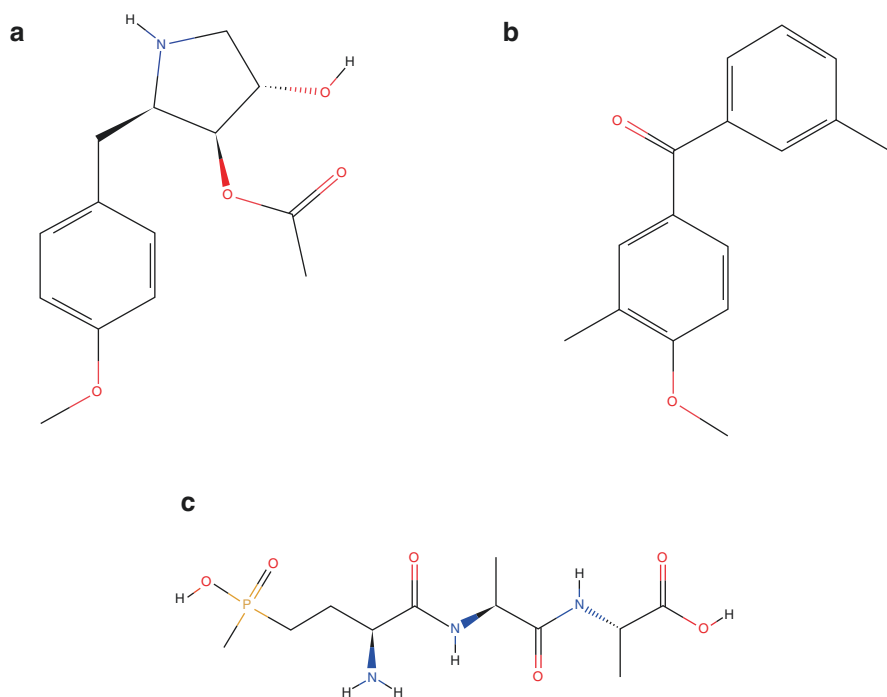
Although there are several commercial products and an increasing number of actinobacteria are being discovered as appropriate candidates for biocontrol of many plant-associated diseases, the important point to be kept in mind is that the development of appropriate bioformulation of products and delivery of the endophytic actinomycetes to viably implement them in practical agronomical production must be efficiently considered.



## 10.4.2 Herbicides and Insecticides

Bioherbicides especially microherbicides are shown to be effective for weed control and are becoming attractive for research and application due to the increase of global environmental consciousness. Bacteria and fungi are microbial sources of bioherbicides or phytotoxins. Anisomycin (Fig. 10.21a), a herbicide obtained from *Streptomyces toyocaensis*, provided the chemical basis for the development of synthetic commercial herbicides such as methoxyphenone (Fig. 10.21b) (Yamada et al. 1972). Anisomycin and methoxyphenone have been reported to display significant activity against barnyard grass as well as crabgrass (Saxena 2015). As another example of industrially relevant actinobacterial herbicides, bialaphos (Fig. 10.21c), which is being marketed in Japan as a broad-spectrum herbicide, was isolated from *Streptomyces viridochromogenes* (Sekizawa and Takematsu 2013).

Table 10.6 shows the most important actinobacterial herbicides being successfully implemented. Although the producer actinobacteria are mostly *Streptomyces* species, there are non-*Streptomyces* actinobacteria reported by Hamedí et al. such as *Nocardia*, *Nocardiopsis*, and *Micromonospora* which were verified to produce the necrosis and ethylene-inducing peptide (NEP)-like family of proteins [Nep-like proteins (NLPs)] as a recently discovered group of phytotoxins (Hamedí et al. 2015b).



**Fig. 10.21** Structure of actinobacterial herbicides: (a) anisomycin, (b) methoxyphenone, and (c) bialaphos

**Table 10.6** Applicable actinobacterial herbicides

Organism	Herbicide	Reference
<i>Streptomyces saganonensis</i>	Herbicides	Duke et al. (2000)
	Herbimycins	
<i>Streptomyces toyocaensis</i>	Anisomycins	Yamada et al. (1972)
<i>Streptomyces hygroscopicus</i>	Carbocyclic coformycin	Pillmoor (1998)
	Hydantocidin	
<i>Streptomyces</i> sp.	Phthoxazolin	YanChu (1993)
	Hydantocidin	
	Homoalanosin	
<i>Streptomyces viridochromogenes</i>	Bialaphos	Sekizawa and Takematsu (2013)

Nep1 is a bioherbicide protein effective against dicotyledonous weeds first isolated from *Fusarium oxysporum*. However, the gene encoding this protein (*nlp*) is also found in many actinobacteria including *Streptomyces* spp. as well as non-*Streptomyces* species which can represent candidates for the production of this bioherbicide (Hamedi et al. 2015b).

There are also various actinobacterial insecticides such as avermectins from *Streptomyces avermitilis* (Putter et al. 1981) which are mainly used in various crops such as citrus, pome fruits (e.g., apples and pears), vegetables, and cotton. Milbemectin—another avermectin derivative—is used to combat the many different mites in tea and pome fruits (e.g., apples). It acts also against pine wood nematode which devastates pine trees. Valinomycin (Heisey et al. 1988) and piericidins (Putter et al. 1981) are two other important insecticides produced by *Streptomyces griseus* and *Streptomyces* sp., respectively.

### 10.4.3 Animal Growth Promoters

After the introduction of antibiotics as therapeutic agents, their role in promoting growth in farm animals was soon discovered. The effect was observed firstly in chickens when feeding fermentation offal from the chlortetracycline production of *Streptomyces aureofaciens*. Since then several kinds of these compounds regarded to as antimicrobial growth promoters (AGPs) were discovered to enhance the growth and decrease the morbidity and mortality rate of farm animals (Butaye et al. 2003). Apparently, actinobacteria as a major source of antibiotics are of notable importance as a source for AGPs. A major part of commercially used AGPs includes those produced by actinobacterial species (especially streptomycetes) which are shown in Table 10.7.

The compounds are classified as non-ionophoretic and ionophore antibiotics. Ionophore antibiotics such as monensin, salinomycin, narasin, and lasalocid are extracted mainly from actinomycetes and usually *Streptomyces* spp. It must be noted that an ideal AGP to be used directly in human-related usages must not have antibiotic activity due to antibiotic resistance issues. Generally, although there are

**Table 10.7** Important AGPs produced from actinobacteria

AGP	Producer organism	Reference
Bambermycin (or meonomycin)	<i>Streptomyces bambergiensis</i>	Huber et al. (1964)
	<i>Streptomyces ghanaensis</i>	
	<i>Streptomyces geysirensis</i>	
	<i>Streptomyces ederenis</i>	
Monensin	<i>Streptomyces cinnamomensis</i>	Haney and Hoehn (1966)
Streptogramins	<i>Streptomyces virginiae</i>	Cocito et al. (1997)
	<i>Streptomyces pristinaspiralis</i>	
Avilamycin	<i>Streptomyces viridochromogenes</i>	Mertz et al. (1986)
Tylosin	<i>Streptomyces fradiae</i>	Hamill et al. (1961)
Salinomycin	<i>Streptomyces albus</i>	Butaye et al. (2003)
Narasin	<i>Streptomyces aureofaciens</i>	Droumev (1983)
Efrotomycin	<i>Nocardia lactamdurans</i>	Frost et al. (1976)

concerns on using AGPs and regulations have been exerted and caused the use of many important AGPs to be banned in some countries, many of them are being widely used in animal husbandry (Dibner and Richards 2005) such as bleomycin, tetracycline, and chlortetracycline (Modi et al. 2011).

## 10.5 Actinobacteria and Yellow Biotechnology

One of the oldest branches of biotechnology is perhaps the field associated with providing human and animal food which is classified as yellow biotechnology in the color code discussed before (although in another classification yellow biotechnology refers to biotechnology of insects). The application of ancient fermentation procedure for the production of wine, cheese, and bread by ancient civilizations can be categorized in this branch. However, currently the yellow biotechnology is mainly concerned with fortifying the nutritional value of human food (especially the production of functional foods) as well as animal feed (Kafarski 2012). Hereby, microbial processing is of great importance due to their vast metabolic and enzymatic potencies and feasibility of production among which the potential of actinobacteria is being discussed.

### 10.5.1 Vitamins

Microorganisms can be successfully used for the commercial production of many of the vitamins; the microbial production of vitamin B<sub>12</sub> (cobalamin), riboflavin, ascorbic acid, and β-carotene is believed to be economically more feasible. Accordingly, actinobacteria show good contributions in the production of many vitamins.

Vitamin B<sub>12</sub> is industrially produced by fermentation of many bacteria mainly by *Propionibacterium freudenreichii* which is able to produce this vitamin for about 206 mg/L as well as *Rhodospseudomonas protamicus* with 135 mg/L production (Martens et al. 2002) and also by *Streptomyces olivaceus* (Hall 1953) and *Propionibacterium shermanii* (Battersby et al. 1977) and to lesser extent by *Micromonospora* sp. (Martens et al. 2002), *Nocardia gardneri* (Balagurunathan and Radhakrishnan 2010), and *Nocardia* sp. (Burgess et al. 2009).

Moreover, in 2010, Falentin et al. reported that *Propionibacterium freudenreichii* possesses a complete enzymatic arsenal for de novo biosynthesis of amino acids and vitamins other than cobalamin (except pantothenate and biotin) (Falentin et al. 2010). As another example, vitamin D-pantothenate, whose production is dependent on the synthesis of the amino acid L-aspartate, can be produced via the well-known actinobacterium *Corynebacterium glutamicum* (Kalinowski et al. 2003). Riboflavin (vitamin B<sub>2</sub>) is reported to be produced in the genetically engineered *Corynebacterium ammoniagenes* which overexpress genes of the enzymes involved in riboflavin biosynthesis resulting in the 17-fold accumulation as much riboflavin as the host strain (Koizumi et al. 2000).

### 10.5.2 Amino Acids

Amino acid production has occupied a great industrial share as being applicable in the food, feed, pharmaceutical, and chemical industry as intermediates. In 2013, the fermentative production of L-glutamate and L-lysine alone was about more than five million tons (Wendisch 2014). Being more economically feasible, currently amino acids are being manufactured by microbial fermentation (Eggeling and Bott 2005). *Corynebacterium glutamicum*, a well-known member of actinobacteria, is the workhorse of fermentative amino acid production which has been used in food biotechnology for more than 50 years (Eggeling and Bott 2005).

During the last three decades, a large number of modern era strain optimization strategies such as genetic and system metabolic engineering, synthetic biology, and classical genetic manipulations were performed on *C. glutamicum* to make it produce and meet the market demand for various amino acids such as L-valine and L-lysine (Blombach et al. 2008; Takeno et al. 2010). L-Glutamic acid is the first and most important amino acid being industrially produced by *C. glutamicum*.

Other important actinobacteria (although used to a lesser extent due to low yield) employed for glutamic acid production belong to genera *Brevibacterium* and *Arthrobacter* (Shiio et al. 1963; Veldkamp et al. 1963). In general, L-lysine, methionine, L-threonine, L-tryptophan, L-valine, and isoleucine are industrially relevant amino acids being produced by *Corynebacteria* (Hermann 2003). As mentioned before, *Brevibacteria* are also implemented as actinobacterial candidates for industrial amino acid production. For instance, *Brevibacterium heali* was used for methionine production, and *Brevibacterium flavum* AJ12429 showed promises in L-arginine production (Ikeda 2003).

---

## 10.6 Actinobacteria and Blue Biotechnology

Blue or marine biotechnology which encompasses the application of biotechnological innovations based on the exploitation of aquatic resources benefits from the great diversity of these environments among which marine microorganisms are of great importance for biotechnological productions and services. Ranging from the discovery of different metabolites to bioremediation, aquatic microorganisms such as marine actinobacteria are being widely studied during the last two decades.

### 10.6.1 Aquaculture

With the rapidly growing global population, demand for food supplies including seafood supply for many countries is greatly increasing. Accordingly, aquaculture is of those food-producing sectors with a fast growing rate. However, disease outbreaks are significant constraints in aquaculture. Although different antimicrobials are being used to overcome the problem, there is a growing concern about antibiotic resistance caused by the misuses of such compounds, and therefore, their use is limited. In this context, probiotic microorganisms are being emergently employed as biological control agents toward a more sustainable aquaculture.

More generally microorganisms can be beneficial in three ways for aquaculture: (1) improvement in the aquacultural environment quality, (2) as biocontrol agents, and (3) the use of their biomass as food source for the nutrition for the sea organisms.

Actinobacteria are undoubtedly excellent producers of antimicrobial secondary metabolites and enzymes that decompose organic macromolecules; they are also tolerant to salt and different pH values, making the good probiotic candidates. Although dominant probiotics being proposed as biological control agents in aquaculture are mostly the lactic acid bacteria (LAB) and the genera *Bacillus*, *Pseudomonas*, or *Burkholderia* (Kesarcodi-Watson et al. 2008), recently there are numerous studies on the potential of actinobacteria (mostly *Streptomyces* spp.) in improving the aquaculture quality as mentioned in Table 10.8.

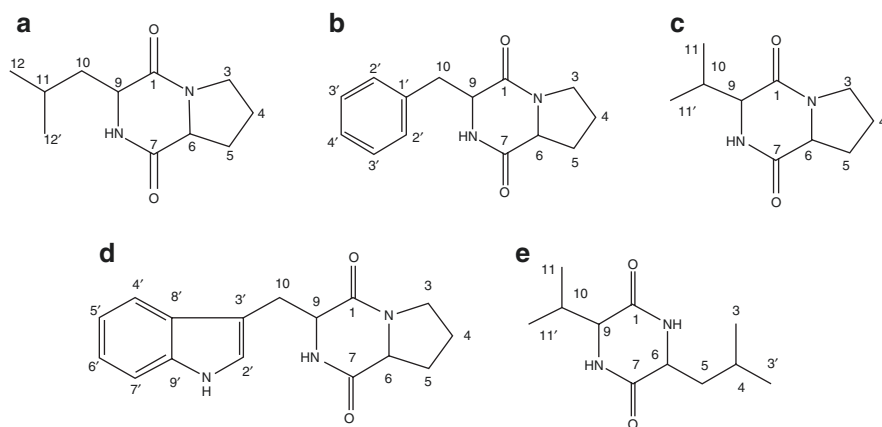
**Table 10.8** Actinobacterial members used in the improvement of aquaculture quality

Organism	Effect	Reference
<i>Streptomyces panacagri</i>	Against vibriosis	Bernal et al. (2015)
<i>Streptomyces flocculus</i>	Against vibriosis	
<i>Streptomyces cinerogriseus</i> A03, A05	Against vibriosis	You et al. (2005)
<i>Bifidobacterium</i> sp.	Promotes metamorphosis and increases the survival rate from nauplius to commercial juvenile shrimp by 55–60%	Zhou et al. (2009)
<i>Micrococcus luteus</i>	Against furunculosis	Irianto and Austin (2002)
<i>Streptomyces griseorubroviolaceus</i> A26, A42	Against vibriosis	You et al. (2005)
<i>Streptomyces</i> sp. AJ8	Against vibriosis	Jenifer et al. (2015)
<i>Streptomyces</i> sp.	Used as single cell protein	Dharmaraj and Dhevendaran (2010)
<i>Streptomyces fradiae</i>	Enhanced water quality by reducing ammonia level	Aftabuddin et al. (2013)
<i>Streptomyces</i> sp. JD9	Good colonization in the host intestine due to low pH resistance	Latha et al. (2016)
<i>Streptomyces rubrolavendulae</i> M56	Against vibriosis	Augustine et al. (2016)

Most of these actinobacteria possess the additional properties of being nontoxic, showing broad-spectrum antimicrobial activity against pathogens as well as having high survival rate in the animal gut and synergistic effect when used in a probiotic mixture, and thus are great candidates to be introduced as probiotics used in food industries such as aquaculture subsector. However, the most important limiting factor of using *Streptomyces* spp. in aquaculture is that they are the producers of geosmin and 2-methylisoborneol (MIB) which are off-flavors in aquatic products which lower the commercial value of the fish and should be overcome (Das et al. 2008; Rurangwa and Verdegem 2015).

### 10.6.2 Antifouling Compounds

Biofouling on marine infrastructure and aquaculture poses a serious problem to the extent that over US \$6.5 billion is spent annually to prevent the problem in marine industry worldwide (Bhadury and Wright 2004). In order to circumvent the issue, antifouling agents have been added to marine environments such as metal biocides (i.e., tributyltin (TBT) and copper) and antifouling paints containing irgarol, diuron, and chlorothalonil are of importance. However, due to their high toxicity for nontarget organisms, the scientific community is in search for safer alternatives (Thomas et al. 2001). In this respect, marine natural products serve as a promising source for discovering antifouling compounds. Accordingly, there have been numerous antifouling natural compounds isolated from marine organisms especially marine microorganisms for sustainable production (Xu et al. 2010). Generally, due to the hardships in cultivating marine bacteria and especially actinobacteria in comparison to the terrestrial species (Haglund et al. 2002), only a limited number of these organisms have been screened for the discovery of antifouling agents. Among these studies, *Streptomyces fungicidicus*, a deep sea isolate actinobacterium, was reported to produce the antifoulant diketopiperazines (Fig. 10.22) which inhibited the barnacle



**Fig. 10.22** Structure of different diketopiperazines isolated from *S. fungicidicus*. (a) Cyclo-(L-Leu-L-Pro); (b) Cyclo-(L-Phe-L-Pro); (c) Cyclo-(L-Val-L-Pro); (d) Cyclo-(L-Trp-L-Pro); (e) Cyclo-(L-Leu-L-Val)

larval attachment effectively (Li et al. 2006). *Streptomyces cinnabarinus* PK209 also was verified as another actinobacterium to produce a diterpene antifoulant in co-culture with *Alteromonas* sp. KNS-16 as an inducer reported by Cho et al. from a screening of more than 180 marine actinomycetes (Cho and Kim 2012). *S. praecox* 291-11 (Cho et al. 2012), *S. fradiae* (Prakash et al. 2015), *S. filamentosus* (Bavya et al. 2011), and *S. albidoflavus* strain UST040711-291 (Qian et al. 2012) are of the most important actinobacterial producers of effective antifouling agents which can be potentially used in antifouling coatings.

---

## 10.7 Actinobacteria and Gray Biotechnology

Gray biotechnology is in connection with the applications directly related to the environmental issues such as mainly contaminant removal and bioremediation. Accordingly, gray biotechnology effectively uses microorganisms and their biocatalysts to isolate and dispose of different substances such as heavy metals and hydrocarbons, with the added possibility of subsequently making use of these substances or by-products from this activity. Due to the microbial potency, gray biotechnology is commonly known as a quest for sustainable solutions to various environmental issues.

### 10.7.1 Recycling of Organic Compounds

Collection, treatment, and disposal of solid wastes are one of the basic economic problems because of environmental burdens, human health concerns, and ecosystem imbalance. The organic fraction of these wastes are believed to be a valuable resource, competent for being transformed into beneficial products especially via the enzymatic potential of microorganisms (Khalid et al. 2011).

Composting has become an increasingly important strategy for the treatment of largely accessible organic wastes which will result in not only acquiring the valuable compost product for raising crops but also the organic waste which will be disposed of safely. The process involves the interaction of different microorganisms within which actinobacterial species become dominant in its later stages. In general, actinobacterial members in compost include *Amycolatopsis*, *Microbispora*, *Planomonospora*, *Micrococcus*, *Saccharopolyspora*, *Micromonospora*, *Thermomonospora*, *Thermobifida*, *Thermobispora*, and *Streptomyces* (Shivlata and Satyanarayana 2015). The prevalence of these bacteria in compost is shown to suppress the growth of plant pathogens due to their ability in secreting antibiotics during the utilization of organic material in composting. This phenomenon is beneficial since the use of compost in order to enhance soil nutrients and also suppress the development of plant diseases becomes possible (Shivlata and Satyanarayana 2015).

Actinobacteria (members of the genera *Corynebacterium*, *Rhodococcus*, and *Streptomyces*) play an important role in the biological degradation process of composting especially for degradation of recalcitrant compounds such as lignocellulosic biomass (Lin and Ballim 2012). As mentioned before, actinobacteria can play vital roles in decomposition of organic material in the environment due to their versatile metabolic potentials. *Isoptericola chiayiensis* and *Isoptericola rhizophila* are reported to be able to hydrolyze organic matter into simpler forms which are further assimilated by plants (Kaur et al. 2014; Tseng et al. 2011). Many actinobacteria can perform the organic material recycling even in harsh environments. Chitin is produced by brine shrimp in bulk quantities in hypersaline soda lakes, and accordingly, the existence of haloalkaliphilic chitinolytic actinobacteria in hypersaline sediments and soda soils was reported. These actinobacteria including *Isoptericola halotolerans*, *Streptomyces sodiiphilus*, *Nocardiopsis* sp., and *Glycomyces harbinensis* are verified to be able to completely degrade chitin faster than other bacteria in such ecological situations (Sorokin et al. 2012).

## 10.7.2 Bioremediation of Toxic Agents

Other than having great metabolic versatility and being abundant in soil, many actinobacterial species are well adapted to harsh environments which make them promising candidates for bioremediation of toxic agents such as heavy metals, pesticides, and hydrocarbons.

### 10.7.2.1 Bioremediation of Heavy Metals

All metals display toxic effects when in high concentrations regardless to their essentiality or nonessentiality for the organism. Moreover, long-term persistence and accumulation of metals, especially heavy metals, in environments can aggravate this problem. For instance, Pb, one of the most persistent metals, has a soil retention time of 150–5000 years (Mani and Kumar 2014). There are different strategies for the remediation of heavy metals such as land filling and leaching, excavation and burial, or soil washing; however, they are mostly expensive and cause secondary issues. Bioremediation which implements the potential of biologic systems such as microorganisms is shown to be less costly, possesses more permanent effects, and is a noninvasive strategy since it does not change the environment profiles and leaves it intact (Mani and Kumar 2014).

Generally, being regarded to as the most toxic inorganic pollutants of soil, heavy metals are the most important group of bioremediation targets. Since many actinobacterial members possess mechanisms of resistance to heavy metals (Amoroso et al. 1998; Hamed et al. 2015a; Schmidt et al. 2005), many of them have been investigated for their potential in bioremediating heavy metals such as copper, nickel, chromium, etc. (Table 10.9).



**Table 10.9** Bioremediation potential of actinobacteria

Bioremediating actinobacteria	Target heavy metal	Reference
<i>Streptomyces</i> sp. F4	Cd (II) in liquid medium and soil microcosms	Manuel et al. (2013)
<i>Microbacterium liquefaciens</i>	Cr (VI)	Pattanapitpaisal et al. (2001)
<i>Streptomyces griseus</i>	Cr (VI)	Laxman and More (2002)
<i>Arthrobacter aurescens</i>	Cr (VI)	Rene’N et al. (2006)
<i>Streptomyces</i> sp. MC1	Cr (VI)	Polti et al. (2009)
<i>Amycolatopsis tucumanensis</i> DSM 45259	Bioimmobilization of Cu (II)	Albarracín et al. (2010)
<i>Streptomyces</i> sp.	Biosorption of Cd (II)	Siñeriz et al. (2009)
<i>Flexivirga alba</i> ST13	Cr (VI)	Sugiyama et al. (2012)
<i>Streptomyces</i> sp. BN3	Pb	El Baz et al. (2015)
<i>Promicromonospora</i> sp. UTMC 2243	Cd (II)	Hamedi et al. (2015a, b)

### 10.7.2.2 Bioremediation of Pesticides

Carbendazim, a broad-spectrum benzimidazole fungicide being widely used in agriculture, is a toxic pesticide to human and other animals. *Rhodococcus jialingiae* djl-6-2 and the consortium containing *Brevibacillus borstelensis* and *Streptomyces albobrisesolus* can efficiently biodegrade carbendazim and hence are candidates for the removal of the carbendazim-polluted soil (Arya and Sharma 2016; Arya et al. 2015).

As another example, *Amycolatopsis* M3-1 has been noted for its capacity to degrade the novel broad-spectrum herbicide ZJ0273 and its intermediates while using it as its sole carbon source (Cai et al. 2012).

Methoxychlor (MTX) is another toxic organochlorine pesticide having estrogenic activity. Although it has been banned in most countries, MTX is still being used in some agricultural products. A defined mixed culture of *Streptomyces* spp. was reported by Fuentes et al. which is capable for MTX removal by 56.4% in soil (Fuentes et al. 2014).

Generally, different genera of actinobacteria including *Arthrobacter*, *Clavibacter*, *Corynebacterium*, *Mycobacterium*, *Nocardia*, *Rhodococcus*, *Micromonospora*, *Nocardioides*, and *Streptomyces* are reported as pesticide-degrading actinobacteria which can degrade pentachlorophenol (PCP), organochlorines, organophosphates, sulfonyleureas, and many other pesticides efficiently (Schrijver and Mot 1999).

### 10.7.2.3 Bioremediation of Polycyclic Aromatic Hydrocarbons (PAHs)

PAHs are believed to be the most important pollutants due to their severe carcinogenicity, mutagenicity, and toxicity. Although various microbial species are capable of degrading PAHs in soil, actinobacteria are good candidates since they can consume a wide range of carbon sources including aromatic lignin molecules (Chaudhary et al. 2011). *Streptomyces rochei*, a biosurfactant-producing actinobacterium, has been reported to efficiently degrade 3–4-ring PAHs such as anthracene, fluorene, phenanthrene, and pyrene soil (Chaudhary et al. 2011). Other PAH-degrading actinobacteria includes *Mycobacterium* sp. strain PYR-1, *Mycobacterium* sp. strain RJGII-135, *Rhodococcus* sp. strain UW1, and *Gordonia* sp. strain BP9 capable of degrading fluoranthene, pyrene, chrysene, and both fluoranthene and pyrene, respectively (Kästner et al. 1994; Kelley et al. 1993; Schneider et al. 1996; Walter et al. 1991).

### 10.7.3 Protection from Corrosion

Corrosion, being defined as the deterioration of metals by interacting with its environment (oxygen, water, and microorganisms), causes huge economic loss. According to the World Corrosion Organization (WCO), the annual cost of corrosion worldwide is estimated to US \$2.2 trillion which is about more than 3% of the world's GDP and thus is a grave issue to be addressed. There are different corrosion control strategies being employed within which microorganisms also show potentials as they are able to change the electrochemical conditions at the metal-solution interface. The exerted changes can result in the induction or inhibition of the corrosion procedure (Lin and Ballim 2012).

Ponmariappan et al. have reported that an actinobacterium isolate is effective in controlling corrosion by decreasing the dissolved oxygen content (Ponmariappan et al. 2004). In another study, a significant reduction in the corrosion rate of steel was observed when the steel had been incubated in cultures of *Rhodococcus* sp. CI25 and *Streptomyces pilosus* DSM 40714 before exposed to the corrosive media which has further elucidated to be due to the formation of crystalline vivianite layer over the steel by *Rhodococcus* sp. CI25 (Volkland et al. 2000). *Streptomyces lunalinharesii* strain 235 is another actinobacterium whose effect in inhibition of *Bacillus subtilis*-related biocorrosion has been recently documented. The inhibitory effect was due to antimicrobial substance produced by the actinobacterium which makes this study the first report on the production of antimicrobial substances by actinomycetes against bacteria involved in biocorrosion (Pacheco da Rosa et al. 2013).

---

## 10.8 Actinobacteria and Gold Biotechnology

The ever-progressing biotechnology is being equipped with novel tools and techniques which accelerate the pace of its progression. These strategies are being assumed as a branch called gold biotechnology which mainly concerns with the integration of nanotechnology to biotechnology as well as the implementations of bioinformatics and in silico approaches to biotechnology. Since microbiology is being increasingly replete with huge amount of biological data available from accessible databases, the development of computational tools to extract knowledge from such data is greatly important, and the implementation of such tools in microbial biotechnology is inevitable. Therefore, these issues are being studied in a separate branch of gold biotechnology and are hereby reviewed in case of actinobacteria.

### 10.8.1 Bioinformatics

As fully discussed in previous sections, actinobacteria have been proved to be the important microbial sources for numerous natural products for over 70 years, and their metabolites have been used widely in medicine, agriculture, and industry (Weber et al. 2015). Although actinobacterial genome and metabolism are evolved to produce a diverse array of molecules, like other microorganisms that produce a desirable product, beneficial metabolites of wild strains have low yields and

productivities. Therefore, in order to reach an industrially relevant process, improvement of the microbial performance is of great importance to reach industrial strains. To do this, random mutagenesis or protoplast fusion and traditional bioprocess development methods have been classically used; however, none of these strategies provide exact understanding of systematic genetic perturbations and lead to improved strains (Otero and Nielsen 2010).

Today, with the development of affordable omics tools especially whole-genome sequencing, biology encounters a huge amount of data demanding careful analysis which is beyond the manual analysis, and therefore the field enters a new phase in the discovery, identification, and improvement in the yields of such molecules. Accordingly, through computational algorithms and in silico strategies, researchers are able to obtain a quantitative phenotypic description of their biological problem by constructing predictive mathematical models from the omics data available for the producer strain (Kohlstedt et al. 2010). These methods mainly regarded to as metabolic engineering are concerned with modeling the organisms' metabolic network and perform network analysis concepts to find hotspots for manipulation either via molecular genetics or other techniques to finally improve the production of metabolites or ameliorating the organisms' properties.

In case of actinobacteria, there are more than 1000 genome sequences as well as a plethora of other omics data available on biological databases for these organisms. When analyzing these so-called big data, these data not only indicate that actinobacteria have the capability to produce many more bioactive secondary metabolites than had been previously elucidated (Doroghazi et al. 2014) but also provide researchers with a systems view based on which they can rationally engineer the strain to improve the yield of a specific metabolite or enhance a biotechnological trait (being regarded to as systems metabolic engineering). For instance, genome guided overexpression of actinorhodin by *S. coelicolor* has been reported which led to a 20-fold increase in actinorhodin production (Murakami et al. 2011). Furthermore, comparative transcriptomics and proteomics studies have been employed to identify alterations in gene expression associated with overproduction of secondary metabolites in industrial *Streptomyces* strains (Chaudhary et al. 2013; Kim et al. 2007; Lee et al. 2009).

### 10.8.2 Production of Nanoparticles (NPs)

NPs are defined as particles with a diameter smaller than 100 nm in at least one dimension. In this size, materials display significantly different chemical and physical properties as well as emergent size-dependent properties, many of which cause specific applications for these materials. Intense scientific research is currently overcome the study of nanoparticles due to their discovered potentials in biomedical, optical, environmental health, space industries, chemical industries, and electrical fields (Iravani et al. 2014). There are different chemical-based

methods for the production of nanoparticles; however, the methods are often not eco-friendly due to the need of toxic chemicals for the production process (Iravani et al. 2014). Therefore, manufacturing of nanoparticles is currently being preferentially performed via exploring different bio-based syntheses mainly through microorganisms.

Actinobacteria can tolerate high concentrations of metal, and also the production of nanoparticles by actinobacteria has proved to show polydispersity property which prevents self-aggregation of nanoparticles (Shivlata and Satyanarayana 2015). The extracellular and intracellular productions of gold nanoparticles by *Thermomonospora* sp. and *Rhodococcus* sp., respectively, are the examples of actinobacterial production of nanoparticles (Ahmad et al. 2003a, b). The metal-resistant actinobacterium *Arthrobacter nitroguajacolicus* isolated from Andaliyan gold mine in northwest of Iran is also reported to be capable of producing gold nanoparticles of 40 nm size (Dehnad et al. 2015).

More recently, silver nanoparticles were reported to be produced by *Streptomyces naganishii* (MA7) which showed to cause antibacterial activity of the strain (Samundeeswari et al. 2012). Other examples of actinobacteria producing extracellular silver nanoparticles include *Streptomyces glaucus* (Tsubakhashvili et al. 2011), *Streptomyces hygroscopicus* (Sadhasivam et al. 2010), marine actinobacterium *Streptomyces albidoflavus* (Prakasham et al. 2012), and *Nocardiaopsis* sp. MBRC-1 (Manivasagan et al. 2013). Table 10.10 shows other actinobacterial producers of nanoparticles to better illustrate their potential in the field.

Generally, actinobacterial production of nanoparticles seems to be increased during the past years, and promising findings were obtained. However, optimizations regarding to the rate of production and reduction of production time must be exerted in order to make the process feasible.

**Table 10.10** Nanoparticles producing actinobacteria

Producer actinobacteria	Nanoparticle type/size (nm)	Activity	Reference
<i>Streptomyces viridogens</i>	Gold/18–20	Antibacterial	Balagurunathan et al. (2011)
<i>Streptomyces naganishii</i>	Silver/5–10	Anti-biofouling; anticancer; antioxidant	Shanmugasundaram et al. (2013)
<i>Thermomonospora</i> sp.	Gold/30–60	Biosensor	Torres-Chavolla et al. (2010)
<i>Streptomyces</i> sp. LK3	Silver/5	Antiparasitic	Karthik et al. (2014)
<i>Streptomyces</i> sp.	Gold/5–50	Antimalarial	Karthik et al. (2013)
<i>Nocardia farcinica</i>	Gold/15–20	Not determined	Oza et al. (2012)
<i>Streptomyces</i> sp. VITDDK3	Gold/90	Antifungal	Gopal et al. (2013)
<i>Gordonia amarae</i>	Gold/15–40	Biosensor	Bennur et al. (2016)

## References

- Abramić M, Leščić I, Korica T, Vitale L, Saenger W, Pigac J (1999) Purification and properties of extracellular lipase from *Streptomyces rimosus*. *Enzym Microb Technol* 25(6):522–529
- Aftabuddin S, Kashem MA, Kader MA, Sikder M, Hakim MA (2013) Use of *Streptomyces fradiae* and *Bacillus megaterium* as probiotics in the experimental culture of tiger shrimp *Penaeus monodon* (Crustacea, Penaeidae). *Aquacult Aquar Conserv Legislat* 6(3):253
- Aharonowitz Y, Demain AL (1978) Carbon catabolite regulation of cephalosporin production in *Streptomyces clavuligerus*. *Antimicrob Agents Chemother* 14(2):159–164
- Ahmad A, Senapati S, Khan MI, Kumar R, Ramani R, Srinivas V, Sastry M (2003a) Intracellular synthesis of gold nanoparticles by a novel alkalotolerant actinomycete, *Rhodococcus* species. *Nanotechnology* 14(7):824
- Ahmad A, Senapati S, Khan MI, Kumar R, Sastry M (2003b) Extracellular biosynthesis of monodisperse gold nanoparticles by a novel extremophilic actinomycete, *Thermomonospora* sp. *Langmuir* 19(8):3550–3553
- Albarracín VH, Amoroso MJ, Abate CM (2010) Bioaugmentation of copper polluted soil microcosms with *Amycolatopsis tucumanensis* to diminish phytoavailable copper for *Zea mays* plants. *Chemosphere* 79(2):131–137
- Amoroso MJ, Castro GR, Carlino FJ, Romero NC, Hill RT, Oliver G (1998) Screening of heavy metal-tolerant actinomycetes isolated from the Sali River. *J Gen Appl Microbiol* 44(2):129–132
- Aoyagi T, Takeuchi T, Matsuzaki A, Kawamura K, Kondo S, Hamada M et al (1969) Leupeptins, new protease inhibitors from actinomycetes. *J Antibiot* 22(6):283–286
- Arcamone F, Cassinelli G, Fantini G, Grein A, Orezzi P, Pol C, Spalla C (1969) Adriamycin, 14-hydroxydaimomycin, a new antitumor antibiotic from *S. Peuceetius* var. *caesius*. *Biotechnol Bioeng* 11(6):1101–1110
- Arya R, Sharma AK (2016) Bioremediation of Carbendazim, a Benzimidazole fungicide using *Brevibacillus borstelensis* and *Streptomyces albobrisesolus* together. *Curr Pharm Biotechnol* 17(2):185–189
- Arya R, Sharma R, Malhotra M, Kumar V, Sharma A (2015) Biodegradation aspects of carbendazim and sulfosulfuron: trends, scope and relevance. *Curr Med Chem* 22(9):1147–1155
- Augustine D, Jacob JC, Philip R (2016) Exclusion of *Vibrio* spp. by an antagonistic marine actinomycete *Streptomyces rubrolavendulae* M56. *Aquacult Res* 47(9):2951–2960
- Balagurunathan R, Radhakrishnan M (2010) Biotechnological, genetic engineering and nanotechnological potential of actinomycetes. In: Maheshwari DK, Dubey RC, Saravanamuthu R (eds) *Industrial exploitation of microorganisms*. IK, New Delhi, pp 302–321
- Balagurunathan R, Radhakrishnan M, Rajendran RB, Velmurugan D (2011) Biosynthesis of gold nanoparticles by actinomycete *Streptomyces viridogens* strain HM10. *Indian J Biochem Biophys* 48(5):331–335
- Baltz RH (2006) Marcel Faber roundtable: is our antibiotic pipeline unproductive because of starvation, constipation or lack of inspiration? *J Ind Microbiol Biotechnol* 33(7):507–513
- Baltz RH (2007) Antimicrobials from actinomycetes: back to the future. *Microbe* 2(3):125
- Battersby AR, McDonald E, Thompson M, Williams DC, Morris HR, Bykhovsky VY et al (1977) Biosynthesis of vitamin B<sub>12</sub>: structural studies on the corrinophyrins from *Propionibacterium shermanii* and the link with sirohydrochlorin. *Tetrahedron Lett* 18(25):2217–2220
- Bavya M, Mohanapriya P, Pazhanimurugan R, Balagurunathan R (2011) Potential bioactive compound from marine actinomycetes against biofouling bacteria. *Ind J Marine Sci* 40(4):578
- Bennur T, Khan Z, Kshirsagar R, Javdekar V, Zinjarde S (2016) Biogenic gold nanoparticles from the Actinomycete *Gordonia amarae*: application in rapid sensing of copper ions. *Sensors Actuators B Chem* 233:684–690
- Bérdy J (2015) Microorganisms producing antibiotics. In: *Antibiotics: current innovations and future trends*. Caister Academic Press, Norfolk, pp 49–64
- Bernal MG, Campa-Córdova ÁI, Saucedo PE, González MC, Marrero RM, Mazón-Suástegui JM (2015) Isolation and in vitro selection of actinomycetes strains as potential probiotics for aquaculture. *Vet World* 8(2):170–176

- Bhadury P, Wright PC (2004) Exploitation of marine algae: biogenic compounds for potential antifouling applications. *Planta* 219(4):561–578
- Bhalla TC, Kumar H (2005) *Nocardia globerula* NHB-2: a versatile nitrile-degrading organism. *Can J Microbiol* 51(8):705–708
- Bickel H, Gäumann E, Nussberger G, Reussner P, Vischer E, Voser W, Wettstein A, Zähler H (1960). Stoffwechselprodukte von Actinomyceten. Über die Isolierung und Charakterisierung der Ferrimycine A1 und A2, neuer Antibiotika der Sideromycin-Gruppe. *Helv Chim Acta* 43:2105–2118
- Bickel H, Mertens P, Prelog V, Seibl J, Walser A. (1966) Stoffwechselprodukte von Mikroorganismen – 53. Über die Konstitution von Ferrimycin A1. *Tetrahedron Suppl.* 8:171–179
- Blombach B, Schreiner ME, Bartek T, Oldiges M, Eikmanns BJ (2008) *Corynebacterium glutamicum* tailored for high-yield L-valine production. *Appl Microbiol Biotechnol* 79(3):471–479
- Bloomquist JR (1993) Toxicology, mode of action and target site-mediated resistance to insecticides acting on chloride channels. *Comp Biochem Physiol C: Pharmacol Toxicol Endocrinol* 106(2):301–314
- Bloomquist JR (1996) Ion channels as targets for insecticides. *Annu Rev Entomol* 41(1):163–190
- Bloomquist JR (2003) Chloride channels as tools for developing selective insecticides. *Arch Insect Biochem Physiol* 54(4):145–156
- Bode HB, Bethe B, Höfs R, Zeeck A (2002) Big effects from small changes: possible ways to explore nature's chemical diversity. *ChemBiochem* 3(7):619–627
- Brockmann H, Niemeyer J (1968) Die absolute Konfiguration der anthracyclinone. *Tetrahedron Lett* 9(45):4719–4724
- Broenstrup M, Koenig C, Toti L, Wink J, Leuschner W, Gassenhuber J et al (2012) Gene cluster for biosynthesis of griselimycin and methylgriselimycin. Google Patents
- Burg RW, Miller BM, Baker EE, Birnbaum J, Currie SA, Hartman R et al (1979) Avermectins, new family of potent anthelmintic agents: producing organism and fermentation. *Antimicrob Agents Chemother* 15(3):361–367
- Burgess CM, Smid EJ, van Sinderen D (2009) Bacterial vitamin B2, B11 and B12 overproduction: an overview. *Int J Food Microbiol* 133(1):1–7
- Butaye P, Devriese LA, Haesebrouck F (2003) Antimicrobial growth promoters used in animal feed: effects of less well known antibiotics on Gram-positive bacteria. *Clin Microbiol Rev* 16(2):175–188
- Cai Z, Chen Q, Wang H, He Y, Wang W, Zhao X, Ye Q (2012) Degradation of the novel herbicide ZJ0273 by *Amycolatopsis* sp. M3-1 isolated from soil. *Appl Microbiol Biotechnol* 96(5):1371–1379
- Charney J, Fisher W, Curran C, Machlowitz R, Tytell A (1953) Streptogramin, a new antibiotic. *Antibiot Chemother* 3(12):1283
- Chaudhary P, Sharma R, Singh SB, Nain L (2011) Bioremediation of PAH by *Streptomyces* sp. *Bull Environ Contam Toxicol* 86(3):268–271
- Chaudhary AK, Dhakal D, Sohng JK (2013) An insight into the “-omics” based engineering of streptomycetes for secondary metabolite overproduction. *BioMed Res Int* 2013:1–15
- Chen C-Y, Huang Y-C, Wei C-M, Meng M, Liu W-H, Yang C-H (2013) Properties of the newly isolated extracellular thermo-alkali-stable laccase from thermophilic actinomycetes, *Thermobifida fusca* and its application in dye intermediates oxidation. *AMB Express* 3(1):1–9
- Cho JY, Kim MS (2012) Induction of antifouling diterpene production by *Streptomyces cinnabarinus* PK209 in co-culture with marine-derived *Alteromonas* sp. KNS-16. *Biosci Biotechnol Biochem* 76(10):1849–1854
- Cho JY, Kang JY, Hong YK, Baek HH, Shin HW, Kim MS (2012) Isolation and structural determination of the antifouling diketopiperazines from marine-derived *Streptomyces praecox* 291-11. *Biosci Biotechnol Biochem* 76(6):1116–1121
- Chopra I, Roberts M (2001) Tetracycline antibiotics: mode of action, applications, molecular biology, and epidemiology of bacterial resistance. *Microbiol Mol Biol Rev* 65(2):232–260
- Cocito C, Di Giambattista M, Nyssen E, Vannuffel P (1997) The molecular mechanism of action of streptogramins and related antibiotics. *Infect Dis Ther Ser* 21:145–172
- Coombs JT, Michelsen PP, Franco CM (2004) Evaluation of endophytic actinobacteria as antagonists of *Gaeumannomyces graminis* var. *tritici* in wheat. *Biol Control* 29(3):359–366

- Crawford D, Kowalski M, Roberts M, Merrell G, Deobald L (2005) Discovery, development, and commercialization of a microbial antifungal biocontrol agent, *Streptomyces lydicus* WYEC108: history of a decade long endeavor. *Soc Ind Microbiol News* 55:88–95
- Das S, Ward LR, Burke C (2008) Prospects of using marine actinobacteria as probiotics in aquaculture. *Appl Microbiol Biotechnol* 81(3):419–429
- Davies J, Wright GD (1997) Bacterial resistance to aminoglycoside antibiotics. *Trends Microbiol* 5(6):234–240
- Dehnad A, Hamedí J, Derakhshan-Khadivi F, Abušov R (2015) Green synthesis of gold nanoparticles by a metal resistant *Arthrobacter nitroguajacolicus* isolated from gold mine. *IEEE Trans Nanobioscience* 14(4):393–396
- Dharmaraj S, Dhevendaran K (2010) Evaluation of *Streptomyces* as a probiotic feed for the growth of ornamental fish *Xiphophorus helleri*. *Food Technol Biotechnol* 48(4):497–504
- Di Marco A, Gaetani M, Orezzi P, Scarpinato B, Silvestrini R, Soldati M et al (1964) 'Daunomycin', a new antibiotic of the rhodomycin group. *Nature* 201:706–707
- Díaz E (2008) Microbial biodegradation: genomics and molecular biology. Horizon Scientific Press, Norfolk
- Dibner J, Richards J (2005) Antibiotic growth promoters in agriculture: history and mode of action. *Poult Sci* 84(4):634–643
- Dodd D, Cann IK (2009) Enzymatic deconstruction of xylan for biofuel production. *GCB Bioenergy* 1(1):2–17
- Donova M (2007) Transformation of steroids by actinobacteria: a review. *Appl Biochem Microbiol* 43(1):1–14
- Donova MV, Egorova OV (2012) Microbial steroid transformations: current state and prospects. *Appl Microbiol Biotechnol* 94(6):1423–1447
- Donovick R, Gold W, Pagano J, Stout H (1954) Amphotericins A and B, antifungal antibiotics produced by a streptomycete. I. In vitro studies. *Antibiot Annu* 3:579–586
- Dorghazi JR, Albright JC, Goering AW, Ju K-S, Haines RR, Tchalukov KA et al (2014) A roadmap for natural product discovery based on large-scale genomics and metabolomics. *Nat Chem Biol* 10(11):963–968
- Droumev D (1983) Review of antimicrobial growth promoting agents available. *Vet Res Commun* 7(1):85–99
- Duggar BM (1948) Aureomycin: a product of the continuing search for new antibiotics. *Ann N Y Acad Sci* 51(2):177–181
- Duke S, Dayan F, Romagni J, Rimando A (2000) Natural products as sources of herbicides: current status and future trends. *Weed Res (Oxf)* 40(1):99–112
- Eggeling L, Bott M (2005) Handbook of *Corynebacterium glutamicum*. CRC Press, Boca Raton
- Ehrlich J, Bartz QR, Smith RM, Joslyn DA (1947) Chloromycetin, a new antibiotic from a soil actinomycete. American Association for the Advancement of Science. *Science* 106(2757):417
- Ehrlich J, Gottlieb D, Burkholder PR, Anderson LE, Pridham T (1948) *Streptomyces venezuelae*, n. sp., the source of chloromycetin. *J Bacteriol* 56(4):467
- Eisenstein BI, Oleson FB, Baltz RH (2010) Daptomycin: from the mountain to the clinic, with essential help from Francis tally, MD. *Clin Infect Dis* 50(Suppl 1):S10–S15
- El Baz S, Baz M, Barakate M, Hassani L, El Gharmali A, Imzilin B (2015) Resistance to and accumulation of heavy metals by actinobacteria isolated from abandoned mining areas. *Sci World J* 2015:761834
- Elshahed MS (2010) Microbiological aspects of biofuel production: current status and future directions. *J Adv Res* 1(2):103–111
- El-Tarabily KA, Sivasithamparan K (2006) Non-streptomycete actinomycetes as biocontrol agents of soil-borne fungal plant pathogens and as plant growth promoters. *Soil Biol Biochem* 38(7):1505–1520
- Enger M, Sleeper B (1965) Multiple cellulase system from *Streptomyces antibioticus*. *J Bacteriol* 89(1):23–27
- Fairbairn D, Priest F, Stark J (1986) Extracellular amylase synthesis by *Streptomyces limosus*. *Enzym Microb Technol* 8(2):89–92

- Falentin H, Deutsch S-M, Jan G, Loux V, Thierry A, Parayre S et al (2010) The complete genome of *Propionibacterium freudenreichii* CIRM-BIA1 T, a hardy Actinobacterium with food and probiotic applications. *PLoS One* 5(7):e11748
- Ferchak J, Pye E (1980) Saccharification of cellulose by the cellulolytic enzyme system of *Thermomonospora* species. I. Stability of cellulolytic activities with respect to time, temperature and pH. *Biotechnol Bioeng* 22:1515–1526
- Féris G, Petrova MI, Andrei G, Huskens D, Hoorelbeke B, Snoeck R et al (2013) The lantibiotic peptide labyrinthopeptin A1 demonstrates broad anti-HIV and anti-HSV activity with potential for microbicidal applications. *PLoS One* 8(5):e64010
- Fernandes TAR, da Silveira WB, Passos FML, Zucchi TD (2014) Characterization of a thermotolerant laccase produced by *Streptomyces* sp. SB086. *Ann Microbiol* 64(3):1363–1369
- Fiedler H-P, Walz F, Döhle A, Zähler H (1985) Albomycin: studies on fermentation, isolation and quantitative determination. *Appl Microbiol Biotechnol* 21(6):341–347
- Finlay A, Hobby G, P'an S, Regna P, Routien J, Seeley D et al (1950) Terramycin, a new antibiotic. American Association for the Advancement of Science. *Science* 111:85–87
- Frost BM, Valiant M, Weissberger B, Dulaney E (1976) Antibacterial activity of efrotomycin. *J Antibiot* 29(10):1083–1091
- Fu C, Keller L, Bauer A, Brönstrup M, Froidbise A, Hammann P et al (2015) Biosynthetic studies of telomycin reveal new lipopeptides with enhanced activity. *J Am Chem Soc* 137(24):7692–7705
- Fuentes MS, Alvarez A, Saez JM, Benimeli CS, Amoroso MJ (2014) Use of actinobacteria consortia to improve methoxychlor bioremediation in different contaminated matrices. In: *Bioremediation in Latin America*. Springer, Cham, pp 267–277
- Fujiwara A, Hoshino T, Westley JW (1985) Anthracycline antibiotics. *Crit Rev Biotechnol* 3(2):133–157
- Galm U, Hager MH, Van Lanen SG, Ju J, Thorson JS, Shen B (2005) Antitumor antibiotics: bleomycin, enediyne, and mitomycin. *Chem Rev* 105(2):739–758
- Gause G (1955) Recent studies on albomycin, a new antibiotic. *Br Med J* 2(4949):1177
- Gause GF, Brazhnikova MG (1951) Die Wirkung von Albomycin gegen Bakterien. *Nov Med* 23:3–7
- Gebauer M, Skerra A (2009) Engineered protein scaffolds as next-generation antibody therapeutics. *Curr Opin Chem Biol* 13(3):245–255
- Genilloud O, González I, Salazar O, Martín J, Tormo JR, Vicente F (2011) Current approaches to exploit actinomycetes as a source of novel natural products. *J Ind Microbiol Biotechnol* 38(3):375–389
- Gessesse A, Gashe BA (1997) Production of alkaline protease by an alkaliphilic bacteria isolated from an alkaline soda lake. *Biotechnol Lett* 19(5):479–481
- Gohel S, Singh S (2015) Thermodynamics of a Ca<sup>2+</sup>-dependent highly thermostable alkaline protease from a haloalkaliphilic actinomycete. *Int J Biol Macromol* 72:421–429
- Golik J, Clardy J, Dubay G, Groenewold G, Kawaguchi H, Konishi M et al (1987) Esperamicins, a novel class of potent antitumor antibiotics. 2. Structure of esperamicin X. *J Am Chem Soc* 109(11):3461–3462
- Gopal JV, Thenmozhi M, Kannabiran K, Rajakumar G, Velayutham K, Rahuman AA (2013) Actinobacteria mediated synthesis of gold nanoparticles using *Streptomyces* sp. VITDDK3 and its antifungal activity. *Mater Lett* 93:360–362
- Gottlieb D, Bhattacharyya P, Anderson H, Carter H (1948) Some properties of an antibiotic obtained from a species of *Streptomyces*. *J Bacteriol* 55(3):409
- Grein A, Spalla C, Dimarco A, Canevazzi G (1963) Descrizione e classificazione di un attinomicete (*Streptomyces peucetius* sp. nova) produttore di una sostanza ad attività antitumorale-La Daunomicina. *Giorn Microbiol* 11(2):109–118
- Griesgraber G, Or YT, Chu DTW, Nilius AM, Johnson PM, Flamm RK et al (1996) 3-Keto-11, 12-carbazate derivatives of 6-O-methylerythromycin A synthesis and in vitro activity. *J Antibiot* 49(5):465–477
- Grundy W, Sinclair A, Theriault R, Goldstein A, Rickher C, Warren H Jr et al (1955) Ristocetin, microbiologic properties. *Antibiot Annu* 1956–1957:687–692
- Gurram SP, Rama P, Sivadevuni G, Solipuram MR (2009) Oxidation of meloxicam by *Streptomyces griseus*. *Iran J Biotechnol* 7(3):142–147



- Gusek TW, Kinsella JE (1987) Purification and characterization of the heat-stable serine proteinase from *Thermomonospora fusca* YX. *Biochem J* 246(2):511–517
- Habbeche A, Saoudi B, Jaouadi B, Haberra S, Kerouaz B, Boudelaa M et al (2014) Purification and biochemical characterization of a detergent-stable keratinase from a newly thermophilic actinomycete *Actinomadura keratinolytica* strain Cpt29 isolated from poultry compost. *J Biosci Bioeng* 117(4):413–421
- Hadar Y (2013) Sources for lignocellulosic raw materials for the production of ethanol. In: *Lignocellulose conversion*. Springer, Berlin Heidelberg, pp 21–38
- Haglund A-L, Törnblom E, Boström B, Tranvik L (2002) Large differences in the fraction of active bacteria in plankton, sediments, and biofilm. *Microb Ecol* 43(2):232–241
- Hall HH (1953) Method for the production of vitamin b12 by *Streptomyces olivaceus*. Google Patents
- Hamamoto T, Gunji S, Tsuji H, Beppu T (1983) Leptomycins A and B, new antifungal antibiotics. I. Taxonomy of the producing strain and their fermentation, purification and characterization. *J Antibiot* 36(6):639–645
- Hamedí J, Mohammadipناه F (2015) Biotechnological application and taxonomical distribution of plant growth promoting actinobacteria. *J Ind Microbiol Biotechnol* 42(2):157–171
- Hamedí J, Dehghani M, Mohammadipناه F (2015a) Isolation of extremely heavy metal resistant strains of rare actinomycetes from high metal content soils in Iran. *Int J Environ Res* 9(2):475–480
- Hamedí J, Moghimi H, Papiran R, Mohammadipناه F (2015b) Screening of phytotoxic activity and nlp genes from rhizosphere actinomycetes. *Ann Microbiol* 65(1):527–532
- Hamill R, Haney M Jr, Stamper M, Willey P (1961) Tylosin, a new antibiotic: II. Isolation, properties, and preparation of pesmycosin, a microbiologically active degradation product. *Antibiot Chemother* 11(5):328–334
- Haney ME Jr, Hoehn MM (1966) Monensin, a new biologically active compound. I. Discovery and isolation. *Antimicrob Agents Chemother* 7:349–352
- Hardter U, Luzhetska M, Ebeling S, Bechthold A (2012) Ethanol production in actinomycetes after expression of synthetic adhB and pdc. *Open Biotechnol J* 6(1):13–16
- Hashimoto M, Komori T, Kamiya T (1976) Nocardicin A, a new monocyclic beta-lactam antibiotic II. Structure determination of nocardicins A and B. *J Antibiot* 29(9):890–901
- Hata T, Hoshi T, Kanamori K, Matsumae A, Sano Y, Shima T, Sugawara R (1956) Mitomycin, a new antibiotic from *Streptomyces*. I. *J Antibiot* 9(4):141
- Hazen EL, Brown R (1950) Two antifungal agents produced by a soil actinomycete. *Science (New York, NY)* 112(2911):423–423
- Heide L (2014) New aminocoumarin antibiotics as gyrase inhibitors. *Int J Med Microbiol* 304(1):31–36
- Heisey RM, Huang J, Mishra SK, Keller JE, Miller JR, Putnam AR, D'Silva TD (1988) Production of valinomycin, an insecticidal antibiotic, by *Streptomyces griseus* var. *flexipertum* var. nov. *J Agric Food Chem* 36(6):1283–1286
- Hermann T (2003) Industrial production of amino acids by coryneform bacteria. *J Biotechnol* 104(1):155–172
- Hesterkamp T (2015) Antibiotics clinical development and pipeline. *Curr Top Microbiol Immunol* 398:447–474
- Hirsch AM, Valdés M (2010) *Micromonospora*: an important microbe for biomedicine and potentially for biocontrol and biofuels. *Soil Biol Biochem* 42(4):536–542
- Hollstein U (1974) Actinomycin. Chemistry and mechanism of action. *Chem Rev* 74(6):625–652
- Huber G, Schacht U, Weidenmüller H, Schmidt-Thomé J, Duphorn J, Tschesche R (1964) Meonomycin, a new antibiotic. II. Characterization and chemistry. *Antimicrob Agents Chemother* 5:737–742
- Ikeda M (2003) Amino acid production processes. In: *Microbial production of l-amino acids*. Springer, Berlin, pp 1–35
- Inui M, Murakami S, Okino S, Kawaguchi H, Vertès AA, Yukawa H (2004) Metabolic analysis of *Corynebacterium glutamicum* during lactate and succinate productions under oxygen deprivation conditions. *J Mol Microbiol Biotechnol* 7(4):182–196

- Iravani S, Korbekandi H, Mirmohammadi S, Zolfaghari B (2014) Synthesis of silver nanoparticles: chemical, physical and biological methods. *Res Pharm Sci* 9(6):385
- Irianto A, Austin B (2002) Use of probiotics to control furunculosis in rainbow trout, *Oncorhynchus mykiss* (Walbaum). *J Fish Dis* 25(6):333–342
- Jacob N, Poorna CA, Prema P (2008) Purification and partial characterization of polygalacturonase from *Streptomyces lydicus*. *Bioresour Technol* 99(14):6697–6701
- Jang H-D, Chen K-S (2003) Production and characterization of thermostable cellulases from *Streptomyces transformant T3-1*. *World J Microbiol Biotechnol* 19(3):263–268
- Jani SA, Chudasama CJ, Patel DB, Bhatt PS, Patel HN (2012) Optimization of extracellular protease production from alkali thermo tolerant actinomycetes: *Saccharomonospora viridis* SJ-21. *Bull Environ Pharmacol Life Sci* 1(6):84–92
- Jaouadi B, Abdelmalek B, Fodil D, Ferradji FZ, Rezik H, Zarái N, Bejar S (2010) Purification and characterization of a thermostable keratinolytic serine alkaline proteinase from *Streptomyces* sp. strain AB1 with high stability in organic solvents. *Bioresour Technol* 101(21):8361–8369
- Jenifer JSCA, Donio MBS, Michaelbabu M, Vincent SGP, Citarasu T (2015) Haloalkaliphilic *Streptomyces* spp. AJ8 isolated from solar salt works and its' pharmacological potential. *AMB Express* 5(1):1–12
- Jovetic S, Zhu Y, Marcone GL, Marinelli F, Tramper J (2010)  $\beta$ -lactam and glycopeptide antibiotics: first and last line of defense? *Trends Biotechnol* 28(12):596–604
- Juhász O, Škárka B (1990) Purification and characterization of an extracellular proteinase from *Brevibacterium linens*. *Can J Microbiol* 36(7):510–512
- Kafarski P (2012) Rainbow code of biotechnology. *CHEMIK Nauka-Technika-Rynek* 1(66):811–816
- Kahan J, Kahan F, Goegelman R, Currie S, Jackson M, Stapley E et al (1979) Thienamycin, a new beta-lactam antibiotic. I. Discovery, taxonomy, isolation and physical properties. *J Antibiot* 32(1):1–12
- Kahne D, Leimkuhler C, Lu W, Walsh C (2005) Glycopeptide and lipoglycopeptide antibiotics. *Chem Rev* 105(2):425–448
- Kalinowski J, Bathe B, Bartels D, Bischoff N, Bott M, Burkovski A et al (2003) The complete *Corynebacterium glutamicum* ATCC 13032 genome sequence and its impact on the production of L-aspartate-derived amino acids and vitamins. *J Biotechnol* 104(1):5–25
- Kamei T, Suzuki H, Matsuzaki M, Otani T, Kondo H, Nakamura S (1979) Cholesterol esterase produced by *Streptomyces lavendulae*. II. Purification and properties as a lipolytic enzyme. *Chem Pharm Bull* 27(7):1704–1707
- Kar S, Ray R (2008) Statistical optimization of alpha-amylase production by *Streptomyces erumpens* MTCC 7317 cells in calcium alginate beads using response surface methodology. *Polish J Microbiol* 57(1):49
- Karmakar M, Ray R (2011) Current trends in research and application of microbial cellulases. *Res J Microbiol* 6(1):41
- Karthik L, Kumar G, Keswani T, Bhattacharyya A, Reddy BP, Rao KB (2013) Marine actinobacterial mediated gold nanoparticles synthesis and their antimalarial activity. *Nanomedicine* 9(7):951–960
- Karthik L, Kumar G, Kirthi AV, Rahuman A, Rao KB (2014) *Streptomyces* sp. LK3 mediated synthesis of silver nanoparticles and its biomedical application. *Bioprocess Biosyst Eng* 37(2):261–267
- Kästner M, Breuer-Jammali M, Mahro B (1994) Enumeration and characterization of the soil microflora from hydrocarbon-contaminated soil sites able to mineralize polycyclic aromatic hydrocarbons (PAH). *Appl Microbiol Biotechnol* 41(2):267–273
- Kaur N, Rajendran MK, Kaur G, Shanmugam M (2014) *Isoptericola rhizophila* sp. nov., a novel actinobacterium isolated from rhizosphere soil. *Antonie Van Leeuwenhoek* 106(2):301–307
- Kelley I, Freeman J, Evans F, Cerniglia C (1993) Identification of metabolites from the degradation of fluoranthene by *Mycobacterium* sp. strain PYR-1. *Appl Environ Microbiol* 59(3):800–806
- Kesarodi-Watson A, Kaspar H, Lategan MJ, Gibson L (2008) Probiotics in aquaculture: the need, principles and mechanisms of action and screening processes. *Aquaculture* 274(1):1–14

- Khalid A, Arshad M, Anjum M, Mahmood T, Dawson L (2011) The anaerobic digestion of solid organic waste. *Waste Manag* 31(8):1737–1744
- Khan N, Filonow A, Singleton L (1997) Augmentation of soil with sporangia of *Actinoplanes* spp. for biological control of *Pythium damping-off*. *Biocontrol Sci Tech* 7(1):11–22
- Khosla R, Verma D, Kapur A, Aruna R, Khanna N (1999) Streptogramins: a new class of antibiotics. *Indian J Med Sci* 53(3):111–119
- Kim SB, Goodfellow M (2002) *Streptomyces avermitilis* sp. nov., nom. rev., a taxonomic home for the avermectin-producing streptomycetes. *Int J Syst Evol Microbiol* 52(6):2011–2014
- Kim YJ, Kim D-O, Chun OK, Shin D-H, Jung H, Lee CY, Wilson DB (2005) Phenolic extraction from apple peel by cellulases from *Thermobifida fusca*. *J Agric Food Chem* 53(24):9560–9565
- Kim YJ, Song JY, Moon MH, Smith CP, Hong S-K, Chang YK (2007) pH shock induces over-expression of regulatory and biosynthetic genes for actinorhodin production in *Streptomyces coelicolor* A3 (2). *Appl Microbiol Biotechnol* 76(5):1119–1130
- Kino T, Hatanaka H, Hashimoto M, Nishiyama M, Goto T, Okuhara M et al (1987) FK-506, a novel immunosuppressant isolated from a *Streptomyces*. I. Fermentation, isolation, and physico-chemical and biological characteristics. *J Antibiot* 40(9):1249–1255
- Kling A, Lukat P, Almeida DV, Bauer A, Fontaine E, Sordello S et al (2015) Targeting DnaN for tuberculosis therapy using novel griselimycins. *Science* 348(6239):1106–1112
- Kluepfel D, Ishaque M (1982) Xylan-induced cellulolytic enzymes in *Streptomyces flavogriseus*. *Dev Ind Microbiol* 23:389–396
- Kluepfel D, Shareck F, Mondou F, Morosoli R (1986) Characterization of cellulase and xylanase activities of *Streptomyces lividans*. *Appl Microbiol Biotechnol* 24(3):230–234
- Kohlstedt M, Becker J, Wittmann C (2010) Metabolic fluxes and beyond—systems biology understanding and engineering of microbial metabolism. *Appl Microbiol Biotechnol* 88(5):1065–1075
- Koizumi S, Yonetani Y, Maruyama A, Teshiba S (2000) Production of riboflavin by metabolically engineered *Corynebacterium ammoniagenes*. *Appl Microbiol Biotechnol* 53(6):674–679
- Krishna P, Arora A, Reddy MS (2008) An alkaliphilic and xylanolytic strain of actinomycetes *Kocuria* sp. RM1 isolated from extremely alkaline bauxite residue sites. *World J Microbiol Biotechnol* 24(12):3079–3085
- Kudo N, Wolff B, Sekimoto T, Schreiner EP, Yoneda Y, Yanagida M et al (1998) Leptomycin B inhibition of signal-mediated nuclear export by direct binding to CRM1. *Exp Cell Res* 242(2):540–547
- Kudo N, Matsumori N, Taoka H, Fujiwara D, Schreiner EP, Wolff B et al (1999) Leptomycin B inactivates CRM1/exportin 1 by covalent modification at a cysteine residue in the central conserved region. *Proc Natl Acad Sci* 96(16):9112–9117
- Kuhad RC, Gupta R, Singh A (2011) Microbial cellulases and their industrial applications. *Enzyme Res* 2011:280696
- Kumar Y, Goodfellow M (2008) Five new members of the *Streptomyces violaceusniger* 16S rRNA gene clade: *Streptomyces castelarensis* sp. nov., comb. nov., *Streptomyces himastatinicus* sp. nov., *Streptomyces mordarskii* sp. nov., *Streptomyces rapamycinicus* sp. nov. and *Streptomyces ruanii* sp. nov. *Int J Syst Evol Microbiol* 58(6):1369–1378
- Kurane R, Suzuki T, Fukuoka S (1984) Purification and some properties of a phthalate ester hydrolyzing enzyme from *Nocardia erythropolis*. *Appl Microbiol Biotechnol* 20(6):378–383
- Lanoob B, Vancanneyt M, Cleenwerck I, Wang L, Li W, Liu Z, Swings J (2002) The search for synonyms among streptomycetes by using SDS-PAGE of whole-cell proteins. Emendation of the species *Streptomyces aurantiacus*, *Streptomyces cacaoi* subsp. *cacaoi*, *Streptomyces caeruleus* and *Streptomyces violaceus*. *Int J Syst Evol Microbiol* 52(3):823–829
- LaPlante KL, Rybak MJ (2004) Daptomycin—a novel antibiotic against Gram-positive pathogens. *Expert Opin Pharmacother* 5(11):2321–2331
- Latha S, Vinothini G, Calvin DJD, Dhanasekaran D (2016) In vitro probiotic profile based selection of indigenous actinobacterial probiont *Streptomyces* sp. JD9 for enhanced broiler production. *J Biosci Bioeng* 121(1):124–131

- Laxman R, More S (2002) Reduction of hexavalent chromium by *Streptomyces griseus*. *Miner Eng* 15(11):831–837
- Lechevalier M, Prauser H, Labeda D, Ruan J-S (1986) Two new genera of nocardioform actinomycetes: *Amycolata* gen. nov. and *Amycolatopsis* gen. nov. *Int J Syst Evol Microbiol* 36(1):29–37
- Leclercq R (2002) Mechanisms of resistance to macrolides and lincosamides: nature of the resistance elements and their clinical implications. *Clin Infect Dis* 34(4):482–492
- Lee MD, Dunne TS, Siegel MM, Chang CC, Morton GO, Borders DB (1987) Calicheamicins, a novel family of antitumor antibiotics. 1. Chemistry and partial structure of calicheamicin gamma. II. *J Am Chem Soc* 109(11):3464–3466
- Lee MD, Manning JK, Williams DR, Kuck NA, Testa RT, Borders DB (1989) Calicheamicins, a novel family of antitumor antibiotics. 3. Isolation, purification and characterization of calicheamicins beta 1Br, gamma 1Br, alpha 2I, alpha 3I, beta 1I, gamma 1I and delta 1I. *J Antibiot* 42(7):1070–1087
- Lee H-N, Im J-H, Lee M-J, Lee SY, Kim E-S (2009) A putative secreted solute binding protein, SCO6569 is a possible AfsR2-dependent down-regulator of actinorhodin biosynthesis in *Streptomyces coelicolor*. *Process Biochem* 44(3):373–377
- Lewis RJ, Tsai FT, Wigley DB (1996) Molecular mechanisms of drug inhibition of DNA gyrase. *BioEssays* 18(8):661–671
- Li X, Dobretsov S, Xu Y, Xiao X, Hung OS, Qian P-Y (2006) Antifouling diketopiperazines produced by a deep-sea bacterium, *Streptomyces fungicidicus*. *Biofouling* 22(3):187–194
- Lin J, Ballim R (2012) Biocorrosion control: current strategies and promising alternatives. *Afr J Biotechnol* 11(91):15736–15747
- Lin L, Ge HM, Yan T, Qin YH, Tan RX (2012) Thaxtomin A-deficient endophytic *Streptomyces* sp. enhances plant disease resistance to pathogenic *Streptomyces scabies*. *Planta* 236(6):1849–1861
- Liu Y, Chen G, Ge F, Li W, Zeng L, Cao W (2011) Efficient biotransformation of cholesterol to androsta-1, 4-diene-3, 17-dione by a newly isolated actinomycete *Gordonia neofelifaecis*. *World J Microbiol Biotechnol* 27(4):759–765
- Ltd LE (2013) Actinogen collaboration with Leaf Energy Ltd on certain bacterial strains from the Actinomycetes family relevant to leaf energy's glycerol pretreatment process
- Luepke KH, Suda KJ, Boucher H, Russo RL, Bonney MW, Hunt TD, Mohr JF (2017) Past, present, and future of antibacterial economics: increasing bacterial resistance, limited antibiotic pipeline, and societal implications. *Pharmacotherapy: The Journal of Human Pharmacology and Drug Therapy* 37(1):71–84
- Luthra U, Khadpekar S, Trivedi A, Shetty A, Kumar H (2015) Biotransformation of 4-androstene-3, 17-dione to androst-1, 4-diene-3, 17-dione by nocardioideis simplex. *World J Pharm Pharm Sci* 4(11):1935–1943
- Maiese WM, Lechevalier MP, Lechevalier HA, Korshalla J, Kuck N, Fantini A et al (1989) Calicheamicins, a novel family of antitumor antibiotics. Taxonomy, fermentation and biological properties. *J Antibiot* 42(4):558–563
- Mancy D, Ninet L, Preud HJ (1973) Antibiotic 18,887 rp. Google Patents
- Mani D, Kumar C (2014) Biotechnological advances in bioremediation of heavy metals contaminated ecosystems: an overview with special reference to phytoremediation. *Int J Environ Sci Technol* 11(3):843–872
- Manivasagan P, Venkatesan J, Senthilkumar K, Sivakumar K, Kim S-K (2013) Biosynthesis, antimicrobial and cytotoxic effect of silver nanoparticles using a novel *Nocardioopsis* sp. MBRC-1. *BioMed Res Int* 2013:1–9
- Manuel SL, Erika K, Mauricio AC (2013) Cadmium bioremediation by a resistant *Streptomyces* strain. In: *Actinobacteria: application in bioremediation and production of industrial enzymes*. CRC Press, Boca Raton, p 122
- Margalith P, Beretta G (1960) Rifomycin. XI. Taxonomic study on *streptomyces mediterranei* nov. sp. *Mycopathol Mycol Appl* 13(4):321–330
- Martens J-H, Barg H, Warren M, Jahn D (2002) Microbial production of vitamin B12. *Appl Microbiol Biotechnol* 58(3):275–285

- Marui M, Nakanishi K, Yasui T (1985) Purification and properties of three types of xylanases induced by methyl  $\beta$ -xyloside from *Streptomyces* sp. *Agric Biol Chem* 49(12):3399–3407
- Mason D, Dietz A, DeBoer C (1963) Lincomycin, a new antibiotic. I. Discovery and biological properties. *Antimicrob Agents Chemother* 1962:554–559
- McCarthy AJ, Peace E, Broda P (1985) Studies on the extracellular xylanase activity of some thermophilic actinomycetes. *Appl Microbiol Biotechnol* 21(3–4):238–244
- McCormick MH, McGuire J, Pittenger G, Pittenger R, Stark W (1954) Vancomycin, a new antibiotic. I. Chemical and biologic properties. *Antibiot Annu* 3:606–611
- McGuire JM, Bunch R, Anderson R, Boaz H, Flynn E, Powell H, Smith J (1952) Ilotycin, a new antibiotic. *Antibiot Chemother (Northfield, IL)* 2(6):281–283
- McKillop C, Elvin P, Kenten J (1986) Cloning and expression of an extracellular  $\alpha$ -amylase gene from *Streptomyces hygroscopicus* in *Streptomyces lividans* 66. *FEMS Microbiol Lett* 36(1):3–7
- McMurry L, Levy S (2000) Tetracycline resistance in gram-positive bacteria. *Gram-positive pathogens*. ASM Press, Washington, DC, pp 660–677
- Meindl K, Schmiederer T, Schneider K, Reicke A, Butz D, Keller S et al (2010) Labyrinthopeptine—eine neue Klasse carbacyclischer Lantibiotika. *Angew Chem* 122(6):1169–1173
- Mertz JL, Peloso JS, Barker BJ, Babbitt GE, Ocolowitz JL, Simson VL, Kline RM (1986) Isolation and structural identification of nine avilamycins. *J Antibiot* 39(7):877–887
- Meyers BR, Kaplan K, Weinstein L (1969) Microbiological and pharmacological behaviour of 7-chloro-lincomycin. *Appl Microbiol* 17:653–655
- Mielenz JR (2001) Ethanol production from biomass: technology and commercialization status. *Curr Opin Microbiol* 4(3):324–329
- Mienda B, Yahya A, Galadima I, Shamsir M (2014) An overview of microbial proteases for industrial applications. *Res J Pharm Biol Chem Sci* 5:388–396
- Miller TW, Chaiet L, Cole DJ, Cole LJ, Flor JE, Goegelman RT et al (1979) Avermectins, new family of potent anthelmintic agents: isolation and chromatographic properties. *Antimicrob Agents Chemother* 15(3):368–371
- Mingeot-Leclercq M-P, Glupczynski Y, Tulkens PM (1999) Aminoglycosides: activity and resistance. *Antimicrob Agents Chemother* 43(4):727–737
- Mitscher LA, Juvarkar JV, Rosenbrook W Jr, Andres WW, Schenck JR, Egan RS (1970) Structure of chelocardin, a novel tetracycline antibiotic. *J Am Chem Soc* 92(20):6070–6071
- Modi C, Mody S, Patel H, Dudhatra G, Kumar A, Sheikh T (2011) Growth promoting use of antimicrobial agents in animals. *J Appl Pharm Sci* 1(8):33–36
- Mohagheghi A, Grohmann K, Himmel M, Leighton L, Updegraff D (1986) Isolation and characterization of *Acidothermus cellulolyticus* gen. nov., sp. nov., a new genus of thermophilic, acidophilic, cellulolytic bacteria. *Int J Syst Evol Microbiol* 36(3):435–443
- Möllmann U, Heinisch L, Bauernfeind A, Köhler T, Ankel-Fuchs D (2009) Siderophores as drug delivery agents: application of the “Trojan Horse” strategy. *Biometals* 22(4):615–624
- Mordarski M, Wiczorek J, Jaworska B (1969) On the conditions of amylase production by actinomycetes. *Arch Immunol Ther Exp* 18(3):375–381
- Moreira A, Phillips J, Humphrey A (1981) Production of cellulases by *Thermomonospora* sp. *Biotechnol Bioeng* 23(6):1339–1347
- Moreira K, Albuquerque B, Teixeira M, Porto A, Lima Filho J (2002) Application of protease from *Nocardiopsis* sp. as a laundry detergent additive. *World J Microbiol Biotechnol* 18(4):309–315
- Mukthavaram R, Jiang P, Saklecha R, Simbery D, Bharati R, Nomura N, Chao Y, Pastorino S (2013) High-efficiency liposomal encapsulation of the tyrosine kinase inhibitor leads to improve in vivo toxicity and tumor response profile. *Int J Nanomedicine* 8:3991–4006
- Müller L (1989) Chemistry, biochemistry and therapeutic potential of microbial  $\alpha$ -glucosidase inhibitors. In: *NoVel microbial products for medicine and agriculture*. Springer, New York, pp 109–116
- Müller R, Wink J (2014) Future potential for anti-infectives from bacteria—how to exploit biodiversity and genomic potential. *Int J Med Microbiol* 304(1):3–13

- Müller L, Junge B, Frommer W, Schmidt D, Truscheit E (1980) Acarbose (BAYg5421) and homologous  $\alpha$ -glucosidase inhibitors from actinoplanaceae. *Enzyme inhibitors*. Verlag Chemie, Weinheim, pp 109–122
- Murakami T, Burian J, Yanai K, Bibb MJ, Thompson CJ (2011) A system for the targeted amplification of bacterial gene clusters multiplies antibiotic yield in *Streptomyces coelicolor*. *Proc Natl Acad Sci* 108(38):16020–16025
- Nagoba B, Vedpathak DV (2011) Medical applications of Siderophores—a review. *Eur J Gen Med* 8(3):229–235
- Nakajima T, Tsukamoto K-I, Watanabe T, Kainuma K, Matsuda K (1984) Purification and some properties of an endo-1, 4- $\beta$ -d-xylanase from *Streptomyces* sp. *J Ferment Technol* 62(3):269–276
- Nawani N, Kapadnis B, Das A, Rao A, Mahajan S (2002) Purification and characterization of a thermophilic and acidophilic chitinase from *Microbispora* sp. V2. *J Appl Microbiol* 93(6):965–975
- Nicolaou K, Dai WM (1991) *Chemie und Biologie von Endiin-Cytostatica/Antibiotica*. *Angew Chem* 103(11):1453–1481
- Nigam PS (2013) Microbial enzymes with special characteristics for biotechnological applications. *Biomol Ther* 3(3):597–611
- Nigam V, Khandelwal A, Gothwal R, Mohan M, Choudhury B, Vidyarthi A, Ghosh P (2009) Nitrilase-catalysed conversion of acrylonitrile by free and immobilized cells of *Streptomyces* sp. *J Biosci* 34(1):21–26
- Ningthoujam DS, Kshetri P, Sanasam S, Nimaichand S (2009) Screening, identification of best producers and optimization of extracellular proteases from moderately halophilic alkalithermotolerant indigenous actinomycetes. *World Appl Sci J* 7(7):907–916
- Nishi K, Yoshida M, Fujiwara D, Nishikawa M, Horinouchi S, Beppu T (1994) Leptomycin B targets a regulatory cascade of *crm1*, a fission yeast nuclear protein, involved in control of higher order chromosome structure and gene expression. *J Biol Chem* 269(9):6320–6324
- Nlshida H, Sakakibara T, Aoki F, Saito T, Ichikawa K, Inagaki T et al (1995) Generation of novel rapamycin structures by microbial manipulations. *J Antibiot* 48(7):657–666
- Okazaki T, Ono M, Aoki A, Fukuda R (1983) Milbemycins, a new family of macrolide antibiotics: producing organism and its mutants. *J Antibiot* 36(4):438–441
- Okazaki T, Takahashi K, Kizuka M, Enokita R (1995) Studies on actinomycetes isolated from plant leaves. *Annu Rep Sankyo Res Lab* 47:97–106
- Okino S, Inui M, Yukawa H (2005) Production of organic acids by *Corynebacterium glutamicum* under oxygen deprivation. *Appl Microbiol Biotechnol* 68(4):475–480
- Oliver T, Prokop J, Bower R, Otto R (1962) Chelocardin, a new broad-spectrum antibiotic. I. Discovery and biological properties. *Antimicrob Agents Chemother*:583–591
- Omura S, Sasaki Y, Iwai Y, Takeshima H (1995) Staurosporine, a potentially important gift from a microorganism. *J Antibiot* 48(7):535–548
- Oppolzer W, Prelog V, Sensi P (1964) The composition of rifamycin B and related rifamycins. *Experientia* 20(6):336–339
- Otero JM, Nielsen J (2010) Industrial systems biology. *Biotechnol Bioeng* 105(3):439–460
- Oyama H, Kinjoh M, Watari M, Murao S (1997) Purification and characterization of an alkaline proteinase produced by *Pimelobacter* sp. Z-483. *J Ferment Bioeng* 84(4):351–353
- Oza G, Pandey S, Gupta A, Kesarkar R, Sharon M (2012) Biosynthetic reduction of gold ions to gold nanoparticles by *Nocardia farcinica*. *J Microbiol Biotechnol Res* 2:511–515
- Pacheco da Rosa J, Korenblum E, Franco-Cirigliano MN, Abreu F, Lins U, Soares R et al (2013) *Streptomyces lunalinharesii* strain 235 shows the potential to inhibit bacteria involved in bio-corrosion processes. *BioMed Res Int* 2013:309769
- Pattanapitpaisal P, Brown N, Macaskie L (2001) Chromate reduction by *Microbacterium liquefaciens* immobilised in polyvinyl alcohol. *Biotechnol Lett* 23(1):61–65
- Pervaiz I, Ahmad S, Madni M, Ahmad H, Khaliq F (2013) Microbial biotransformation: a tool for drug designing. *Appl Biochem Microbiol* 49(5):437–450
- Pillmoor JB (1998) Carbocyclic coformycin: a case study of the opportunities and pitfalls in the industrial search for new agrochemicals from nature. *Pestic Sci* 52(1):75–80

- Polti MA, García RO, Amoroso MJ, Abate CM (2009) Bioremediation of chromium (VI) contaminated soil by *Streptomyces* sp. MC1. *J Basic Microbiol* 49(3):285–292
- Ponmariappan S, Maruthamuthu S, Palaniswamy N, Palaniappan R (2004) Corrosion control by bacterial biofilms—an overview. *Corros Rev* 22(4):307–324
- Prakash S, Ramasubburayan R, Iyapparaj P, Arthi APR, Ahila NK, Ramkumar VS et al (2015) Environmentally benign antifouling potentials of triterpene-glycosides from *Streptomyces* fradiae: a mangrove isolate. *RSC Adv* 5(37):29524–29534
- Prakasham RS, Buddana S, Yannam S, Guntuku G (2012) Characterization of silver nanoparticles synthesized by using marine isolate *Streptomyces albidoflavus*. *J Microbiol Biotechnol* 22(5):614–621
- Pramanik A, Stroehrer UH, Krejci J, Standish AJ, Bohn E, Paton JC et al (2007) Albomycin is an effective antibiotic, as exemplified with *Yersinia enterocolitica* and *Streptococcus pneumoniae*. *Int J Med Microbiol* 297(6):459–469
- Prasad GS, Girisham S, Reddy S (2010) Microbial transformation of albendazole. *Indian J Expt Biol* 48:415–420
- Purushe S, Prakash D, Nawani NN, Dhakephalkar P, Kapadnis B (2012) Biocatalytic potential of an alkalophilic and thermophilic dextranase as a remedial measure for dextran removal during sugar manufacture. *Bioresour Technol* 115:2–7
- Purushothaman Y (2015) Process optimization and transesterification of *Jatropha curcas* L oil by *Actinomycetes* lipases for biodiesel production
- Putter I, Mac Connell J, Preiser F, Haidri A, Ristich S, Dybas R (1981) Avermectins: novel insecticides, acaricides and nematocides from a soil microorganism. *Experientia* 37(9):963–964
- Qian P, Xu Y, Zhou X, He H, Fusetani N, Dai W-M (2012) Antifouling furan-2-one derivatives. Google Patents
- Rebstock MC, Crooks HM, Controulis J, Bartz QR (1949) Chloramphenicol (chloromycetin). I IV. Ia chemical studies. *J Am Chem Soc* 71(7):2458–2462
- Rene N H, Apel WA, Thompson VS, Sheridan PP (2006) Low temperature reduction of hexavalent chromium by a microbial enrichment consortium and a novel strain of *Arthrobacter aureus*. *BMC Microbiol* 6(1):1
- Rifaat HM, Hassanein SM, El-Said OH, Saleh SA, Selim MS (2005) Purification and characterisation of extracellular neutral protease from *Streptomyces microflavus*. *Arab J Biotechnol* 9:51–60575
- Rohamare S, Gaikwad S, Jones D, Bhavnani V, Pal J, Sharma R, Chatterjee P (2015) Cloning, expression and in silico studies of a serine protease from a marine actinomycete (*Nocardia* sp. NCIM 5124). *Process Biochem* 50(3):378–387
- Rurangwa E, Verdegem MC (2015) Microorganisms in recirculating aquaculture systems and their management. *Rev Aquac* 7(2):117–130
- Sabaratnam S, Traquair JA (2002) Formulation of a *Streptomyces* biocontrol agent for the suppression of *Rhizoctonia* damping-off in tomato transplants. *Biol Control* 23(3):245–253
- Sadhasivam S, Shanmugam P, Yun K (2010) Biosynthesis of silver nanoparticles by *Streptomyces hygroscopicus* and antimicrobial activity against medically important pathogenic microorganisms. *Colloids Surf B: Biointerfaces* 81(1):358–362
- Samundeeswari A, Dhas SP, Nirmala J, John SP, Mukherjee A, Chandrasekaran N (2012) Biosynthesis of silver nanoparticles using actinobacterium *Streptomyces albogriseolus* and its antibacterial activity. *Biotechnol Appl Biochem* 59(6):503–507
- Saraf M, Hastings A (2010) Biofuels, the role of biotechnology to improve their sustainability and profitability. In: *Biodiversity, biofuels, agroforestry and conservation agriculture*. Springer, Dordrecht, pp 123–148
- Saxena S (2015) *Applied microbiology*. Springer, New Delhi
- Scheinfeld N (2003) Telithromycin: a brief review of a new ketolide antibiotic. *J Drugs Dermatol* 3(4):409–413
- Scherlach K, Hertweck C (2009) Triggering cryptic natural product biosynthesis in microorganisms. *Org Biomol Chem* 7(9):1753–1760

- Schlehuber S, Skerra A (2005) Anticalins as an alternative to antibody technology. *Expert Opin Biol Ther* 5(11):1453–1462
- Schmidt A, Haferburg G, Sineriz M, Merten D, Büchel G, Kothe E (2005) Heavy metal resistance mechanisms in actinobacteria for survival in AMD contaminated soils. *Chem Erde-Geochem* 65:131–144
- Schneider J, Grosser R, Jayasimhulu K, Xue W, Warshawsky D (1996) Degradation of pyrene, benz [a] anthracene, and benzo [a] pyrene by *Mycobacterium* sp. strain RJGII-135, isolated from a former coal gasification site. *Appl Environ Microbiol* 62(1):13–19
- Schomburg I, Chang A, Schomburg D (2002) BRENDA, enzyme data and metabolic information. *Nucleic Acids Res* 30(1):47–49
- Schrijver AD, Mot RD (1999) Degradation of pesticides by actinomycetes. *Crit Rev Microbiol* 25(2):85–119
- Sebek O, Perlman D (1979) Microbial transformation of steroids and sterols. *Microb Technol Microb Process* 1:483–496
- Sehgal S, Baker H, Vézina C (1975) Rapamycin (AY-22,989), a new antifungal antibiotic. II. Fermentation, isolation and characterization. *J Antibiot* 28(10):727–732
- Sekizawa Y, Takematsu T (2013) How to discover new antibiotics for herbicidal use. Paper presented at the natural products: proceedings of the 5th international congress of pesticide chemistry, Kyoto, Japan, 29 Aug–4 Sept 1982
- Sensi P, Greco A, Ballotta R (1958) Rifomycin. I. Isolation and properties of rifomycin B and rifomycin complex. *Antibiot Annu* 7:262–270
- Shanmugasundaram T, Radhakrishnan M, Gopikrishnan V, Pazhanimurugan R, Balagurunathan R (2013) A study of the bactericidal, anti-biofouling, cytotoxic and antioxidant properties of actinobacterially synthesised silver nanoparticles. *Colloids Surf B: Biointerfaces* 111:680–687
- Shen B, Du L, Sanchez C, Chen M, Edwards DJ (1999) Bleomycin biosynthesis in *Streptomyces verticillus* ATCC15003: a model of hybrid peptide and polyketide biosynthesis. *Bioorg Chem* 27(2):155–171
- Shen M, Liu Z-Q, Zheng Y-G, Shen Y-C (2009) Enhancing endo-nitrilase production by a newly isolated *Arthrobacter nitroguajacolicus* ZJUTB06-99 through optimization of culture medium. *Biotechnol Bioprocess Eng* 14(6):795–802
- Shiio I, Ôtsuka S-I, Katsuya N (1963) Cellular permeability and extracellular formation of glutamic acid in *Brevibacterium flavum*. *J Biochem* 53(5):333–340
- Shimizu M (2011) Endophytic actinomycetes: biocontrol agents and growth promoters. In: *Bacteria in agrobiology: plant growth responses*. Springer, Berlin, pp 201–220
- Shivlata L, Satyanarayana T (2015) Thermophilic and alkaliphilic actinobacteria: biology and potential applications. *Front Microbiol* 6:1014
- Siñeriz ML, Kothe E, Abate CM (2009) Cadmium biosorption by *Streptomyces* sp. F4 isolated from former uranium mine. *J Basic Microbiol* 49(S1):S55–S62
- Soetaert W, Vandamme E (2006) The impact of industrial biotechnology. *Biotechnol J* 1(7–8):756–769
- Solans M, Vobis G, Cassán F, Luna V, Wall LG (2011) Production of phytohormones by root-associated saprophytic actinomycetes isolated from the actinorhizal plant *Ochetophila triner-vis*. *World J Microbiol Biotechnol* 27(9):2195–2202
- Somma S, Gastaldo L, Corti A (1984) Teicoplanin, a new antibiotic from *Actinoplanes teichomyceticus* nov. sp. *Antimicrob Agents Chemother* 26(6):917–923
- Sorokin DY, van Pelt S, Tourova TP, Evtushenko LI (2009) Nitriliruptor alkaliphilus gen. nov., sp. nov., a deep-lineage haloalkaliphilic actinobacterium from soda lakes capable of growth on aliphatic nitriles, and proposal of Nitriliruptoraceae fam. nov. and Nitriliruptorales ord. nov. *Int J Syst Evol Microbiol* 59(2):248–253
- Sorokin D, Tourova T, Sukhacheva M, Mardanov A, Ravin N (2012) Bacterial chitin utilisation at extremely haloalkaline conditions. *Extremophiles* 16(6):883–894
- Souza PM (2010) Application of microbial  $\alpha$ -amylase in industry—a review. *Braz J Microbiol* 41(4):850–861



- Stamford T, Stamford N, Coelho L, Araujo J (2001) Production and characterization of a thermostable  $\alpha$ -amylase from *Nocardiopsis* sp. endophyte of yam bean. *Bioresour Technol* 76(2):137–141
- Stefanska AL, Fulston M, Houge-Frydrych CS, Jones JJ, Warr SR (2000) A potent seryl tRNA synthetase inhibitor SB-217452 isolated from a *Streptomyces* species. *J Antibiot* 53(12):1346–1353
- Stutzenberger FJ (1971) Cellulase production by *Thermomonospora curvata* isolated from municipal solid waste compost. *Appl Microbiol* 22(2):147–152
- Stutzenberger FJ (1972) Cellulolytic activity of *Thermomonospora curvata*: optimal assay conditions, partial purification, and product of the cellulase. *Appl Microbiol* 24(1):83–90
- Stutzenberger F, Carnell R (1977) Amylase production by *thermomonospora curvata*. *Appl Environ Microbiol* 34(2):234
- Suganuma T, Mizukami T, Moori K-I, Ohnishi M, Hiromi K (1980) Studies of the action pattern of an  $\alpha$ -amylase from *Streptomyces praecox* NA-273. *J Biochem* 88(1):131–138
- Sugiyama T, Sugito H, Mamiya K, Suzuki Y, Ando K, Ohnuki T (2012) Hexavalent chromium reduction by an actinobacterium *Flexivirga alba* ST13 T in the family Dermacoccaceae. *J Biosci Bioeng* 113(3):367–371
- Takahashi Y, Matsumoto A, Seino A, Ueno J, Iwai Y, Omura S (2002) *Streptomyces avermectinius* sp. nov., an avermectin-producing strain. *Int J Syst Evol Microbiol* 52(6):2163–2168
- Takegawa K, Mai L, Miyauchi C, Iwahara S (1993) Purification and characterization of alkaline proteinase from *Arthrobacter protophormiae*. Technical Bulletin of Faculty of Agriculture-Kagawa University, Japan
- Takeshima H (1992) Antiviral agents, in *The Search for Bioactive Compounds from Microorganisms*, Springer Science & Business Media: 45–62
- Takeo S, Murata R, Kobayashi R, Mitsuhashi S, Ikeda M (2010) Engineering of *Corynebacterium glutamicum* with an NADPH-generating glycolytic pathway for L-lysine production. *Appl Environ Microbiol* 76(21):7154–7160
- Tagiguchi Y, Mishima H, Okuda M, Terao M, Aoki A, Fukuda R (1980) Milbemycins, a new family of macrolide antibiotics: fermentation, isolation and physico-chemical properties. *J Antibiot* 33(10):1120–1127
- Takita T, Muraoka Y, Yoshioka T, Fujii A, Maeda K, Umezawa H (1972) The chemistry of bleomycin. IX. *J Antibiot* 25(12):755–758
- Tanaka Y (1992) Antifungal Agents in The search for bioactive compounds from microorganisms Satoshi Omura (ed.), Springer, New York
- Terlain B, Thomas J (1971) Structure of griselimycin, polypeptide antibiotic extracted *Streptomyces* cultures. I. Identification of the products liberated by hydrolysis. *Bull Soc Chim Fr* 6:2349–2356
- Thomas KV, Fileman TW, Readman JW, Waldock MJ (2001) Antifouling paint booster biocides in the UK coastal environment and potential risks of biological effects. *Mar Pollut Bull* 42(8):677–688
- Tominaga Y, Tsujisaka Y (1976) Purifications and some properties of two chitinases from *Streptomyces orientalis* which lyse *Rhizopus* cell wall. *Agric Biol Chem* 40(12):2325–2333
- Torres-Chavolla E, Ranasinghe RJ, Alcolija EC (2010) Characterization and functionalization of biogenic gold nanoparticles for biosensing enhancement. *IEEE Trans Nanotechnol* 9(5):533–538
- Touioui SB, Jaouadi NZ, Boudjella H, Ferradji FZ, Belhoul M, Rekić H et al (2015) Purification and biochemical characterization of two detergent-stable serine alkaline proteases from *Streptomyces* sp. strain AH4. *World J Microbiol Biotechnol* 31(7):1079–1092
- Trejo WH, Bennett R (1963) *Streptomyces nodosus* sp. n., the amphotericin-producing organism. *J Bacteriol* 85(2):436–439
- Truscheit E, Frommer W, Junge B, Müller L, Schmidt DD, Wingender W (1981) Chemie und Biochemie mikrobieller  $\alpha$ -Glucosidasen-Inhibitoren. *Angew Chem* 93(9):738–755
- Tseng M, Liao H-C, Chiang W-P, Yuan G-F (2011) *Isoptericola chiayiensis* sp. nov., isolated from mangrove soil. *Int J Syst Evol Microbiol* 61(7):1667–1670

- Tsibakhashvili NY, Kirkesali EI, Pataraya DT, Gurielidze MA, Kalabegishvili TL, Gvarjaladze DN et al (2011) Microbial synthesis of silver nanoparticles by *Streptomyces glaucus* and *Spirulina platensis*. *Adv Sci Lett* 4(11–12):3408–3417
- Tsujibo H, Miyamoto K, Hasegawa T, Inamori Y (1990) Purification and characterization of two types of alkaline serine proteases produced by an alkalophilic actinomycete. *J Appl Bacteriol* 69(4):520–529
- Umezawa H, Maeda K, Takeuchi T, Okami Y (1966) New antibiotics, bleomycin A and B. *J Antibiot* 19(5):200
- Umezawa S, Tatsuta K, Fujimoto K, Tsuchiya T, Umezawa H, Naganawa H (1972) Structure of antipain, a new sakaguchi-positive product of streptomycetes. *J Antibiot* 25(4):267–270
- Umezawa H, Aoyagi T, Suda H, Hamada M, Takeuchi T (1976) Bestatin, an inhibitor of aminopeptidase B, produced by actinomycetes. *J Antibiot* 29(1):97–99
- Vajjayanthi G, Vijayakumar R, Dhanasekaran D (2016) Actinobacteria—a biofactory of novel enzymes
- Velankar H, Clarke KG, du Preez R, Cowan DA, Burton SG (2010) Developments in nitrile and amide biotransformation processes. *Trends Biotechnol* 28(11):561–569
- Veldkamp H, Van Den Berg G, Zevenhuizen L (1963) Glutamic acid production by *Arthrobacter globiformis*. *Antonie Van Leeuwenhoek* 29(1):35–51
- Vétesy L, Aretz W, Fehlhaber HW, Kogler H (1995) Salmycin A–D, Antibiotika aus *Streptomyces violaceus*, DSM 8286, mit Siderophor-Aminoglycosid-Struktur. *Helv Chim Acta* 78(1):46–60
- Vezina C, Kudelski A, Sehgal S (1975) Rapamycin (AY-22,989), a new antifungal antibiotic. I. Taxonomy of the producing streptomycete and isolation of the active principle. *J Antibiot* 28(10):721–726
- Vicente M, Basilio A, Cabello A, Peláez F (2003) Microbial natural products as a source of antifungals. *Clinical microbiology and infection* 9(1):15–32
- Vickers AA, Chopra I, O’neill AJ (2007) Intrinsic novobiocin resistance in *Staphylococcus saprophyticus*. *Antimicrob Agents Chemother* 51(12):4484–4485
- Viikari L, Alapuranen M, Puranen T, Vehmaanperä J, Siika-Aho M (2007) Thermostable enzymes in lignocellulose hydrolysis. In: *Biofuels*. Springer, Berlin, pp 121–145
- Volkland HP, Harms H, Knopf K, Wanner O, Zehnder AJ (2000) Corrosion inhibition of mild steel by bacteria. *Biofouling* 15(4):287–297
- Waksman SA, Woodruff HB (1940) Bacteriostatic and bactericidal substances produced by a soil actinomycete. *Exp Biol Med* 45(2):609–614
- Waksman SA, Woodruff HB (1941) *Actinomyces antibioticus*, a new soil organism antagonistic to pathogenic and non-pathogenic bacteria. *J Bacteriol* 42(2):231
- Walter U, Beyer M, Klein J, Rehm H-J (1991) Degradation of pyrene by *Rhodococcus* sp. UW1. *Appl Microbiol Biotechnol* 34(5):671–676
- Weber T, Charusanti P, Musiol-Kroll EM, Jiang X, Tong Y, Kim HU, Lee SY (2015) Metabolic engineering of antibiotic factories: new tools for antibiotic production in actinomycetes. *Trends Biotechnol* 33(1):15–26
- Weigel A (2003) Triple-threat microbe gained powers from another bug. *Science* 302(5650):1488
- Wendisch VF (2014) Microbial production of amino acids and derived chemicals: synthetic biology approaches to strain development. *Curr Opin Biotechnol* 30:51–58
- Wink JM, Kroppenstedt RM, Ganguli BN, Nadkarni SR, Schumann P, Seibert G, Stackebrandt E (2003) Three new antibiotic producing species of the genus *Amycolatopsis*, *Amycolatopsis balhimycina* sp. nov., *A. tolypomycina* sp. nov., *A. vancoresmycina* sp. nov., and description of *Amycolatopsis keratiniphila* subsp. *keratiniphila* subsp. nov. and *A. keratiniphila* subsp. *nogabecina* subsp. nov. *Syst Appl Microbiol* 26(1):38–46
- Wink J, Gandhi J, Kroppenstedt RM, Seibert G, Sträubler B, Schumann P, Stackebrandt E (2004) *Amycolatopsis decaplanina* sp. nov., a novel member of the genus with unusual morphology. *Int J Syst Evol Microbiol* 54(1):235–239

- Wink JM, Kroppenstedt RM, Schumann P, Seibert G, Stackebrandt E (2006) *Actinoplanes liguriensis* sp. nov. and *Actinoplanes teichomyceticus* sp. nov. *Int J Syst Evol Microbiol* 56(9):2125–2130
- Wink J, Schumann P, Atasayar E, Klenk H-P, Zaburannyi N, Westermann M, Kämpfer P (2017) ‘*Streptomyces caelicus*’, an antibiotic-producing species of the genus *Streptomyces*, and *Streptomyces canchipurensis* Li et al. 2015 are later heterotypic synonyms of *Streptomyces muensis* Ningthoujam et al. 2014. *Int J Syst Evol Microbiol* 67(3):548–556
- Xiao K, Kinkel LL, Samac DA (2002) Biological control of Phytophthora root rots on alfalfa and soybean with *Streptomyces*. *Biol Control* 23(3):285–295
- Xin Y, Sun Z, Chen Q, Wang J, Wang Y, Luogong L et al (2015) Purification and characterization of a novel extracellular thermostable alkaline protease from *Streptomyces* sp. M30. *J Microbiol Biotechnol* 25(11):1944
- Xu Y, He H, Schulz S, Liu X, Fusetani N, Xiong H et al (2010) Potent antifouling compounds produced by marine *Streptomyces*. *Bioresour Technol* 101(4):1331–1336
- Yamada O, Kaise Y, Futatsuya F, Ishida S, Ito K, Yamamoto H, Munakata K (1972) Studies on plant growth-regulating activities of anisomycin and toyocamycin. *Agric Biol Chem* 36(11):2013–2015
- YanChu S (1993) New developments of agricultural antibiotic pesticide. *Trans (China)* 15(6):5–12
- Yang C-H, Liu W-H (2004) Purification and properties of a maltotriose-producing  $\alpha$ -amylase from *Thermobifida fusca*. *Enzym Microb Technol* 35(2):254–260
- Yang C-H, Liu W-H (2007) Cloning and characterization of a maltotriose-producing  $\alpha$ -amylase gene from *Thermobifida fusca*. *J Ind Microbiol Biotechnol* 34(4):325–330
- You J, Cao L, Liu G, Zhou S, Tan H, Lin Y (2005) Isolation and characterization of actinomycetes antagonistic to pathogenic *Vibrio* spp. from nearshore marine sediments. *World J Microbiol Biotechnol* 21(5):679–682
- Zhanel GG, Walters M, Noreddin A, Vercaigne LM, Wierzbowski A, Embil JM et al (2002) The ketolides: a critical review. *Drugs* 62(12):1771–1804
- Zhang J, Wang M, Sun H, Li X, Zhong L (2009) Isolation and characterization of *Rhodococcus ruber* CGMCC3090 that hydrolyzes aliphatic, aromatic and heterocyclic nitriles. *Afr J Biotechnol* 8(20):5467–5475
- Zhang J, Siika-Aho M, Puranen T, Tang M, Tenkanen M, Viikari L (2011) Thermostable recombinant xylanases from *Nonomuraea flexuosa* and *Thermoascus aurantiacus* show distinct properties in the hydrolysis of xylans and pretreated wheat straw. *Biotechnol Biofuels* 4(1):1
- Zhou Q, Li K, Jun X, Bo L (2009) Role and functions of beneficial microorganisms in sustainable aquaculture. *Bioresour Technol* 100(16):3780–3786

Joachim Wink, Fatemeh Mohammadipناه,  
and Hamed Kazemi Shariat Panahi

---

## 11.1 Morphological Investigation

### 11.1.1 Macroscopic

#### 11.1.1.1 The Aerial Mycelium and Its Color

More than other bacteria Actinobacteria, especially the mycelium forming ones impress by their appearance, the color of the aerial mycelium, of the substrate mycelium and also of pigments that diffuse into the agar (Cross 1989; Krasil'nikov 1979; Küster 1976) and the morphology of their differentiation stages (Gottlieb 1961) which will be described in the later chapters. The aerial mycelium which makes them look like a fungus and the often three dimensional shape of the colony. The color of the aerial mycelium has been used by many groups for a first classification (Flaig and Kutzner 1960; Ettlinger et al. 1958; Shirling and Gottlieb 1966; Tresner and Backus 1963). The main classification groups are: white, grey white, cream (*Streptomyces albus*); yellow-grey (*Streptomyces griseus*); rose, pale violet (*Streptomyces fradiae*, *Microbispora rosea*), rose-grey (*Streptomyces lavendulae*); pale brown, red brown (*Streptomyces fragilis*); pale blue, grey-blue (*Streptomyces viridochromogenes*); blue green (*Streptomyces glaucescens*, *Actinomadura rubrob-runnea*); pale green, green (*Streptomyces prasinus*, *Microtetraspora viridis*); pale grey, grey (*Streptomyces violaceoruber*, *Microtetraspora glauca*) (Blinov and Khokhlov 1970). By the description of the aerial mycelium color three points have

---

J. Wink (✉)

Helmholtz Centre for Infection Research, Braunschweig, Germany

e-mail: [Joachim.Wink@helmholtz-hzi.de](mailto:Joachim.Wink@helmholtz-hzi.de)

F. Mohammadipناه (✉) • H. Kazemi Shariat Panahi

Department of Microbial Biotechnology, School of Biology and Center of Excellence in

Phylogeny of Living Organisms, College of Science, University of Tehran,

14155-6455 Tehran, Iran

e-mail: [fmohammadipناه@ut.ac.ir](mailto:fmohammadipناه@ut.ac.ir)

to be kept in mind. The first is that the typical color is only expressed if the culture is also sporulating. Different species often sporulate on different media, so a number of agar cultures have to be prepared to get good results. The second is the diffusion of pigments from the substrate mycelium into the aerial mycelium which can have influences on the shade of the aerial mycelium. The third is the experience with many different Actinobacteria and their pigmentation, to do this grouping well. It is therefore very important to use the same media and culture conditions for all strains that will be compared. Over the years the use of the media from Shirling and Gottlieb (1966) from the “International Streptomyces Project/ISP” has been established in nearly all labs working with Actinobacteria (composition of media, see Sect. 11.2.1).

### 11.1.1.2 Color of the Substrate Mycelium and the Soluble Pigments

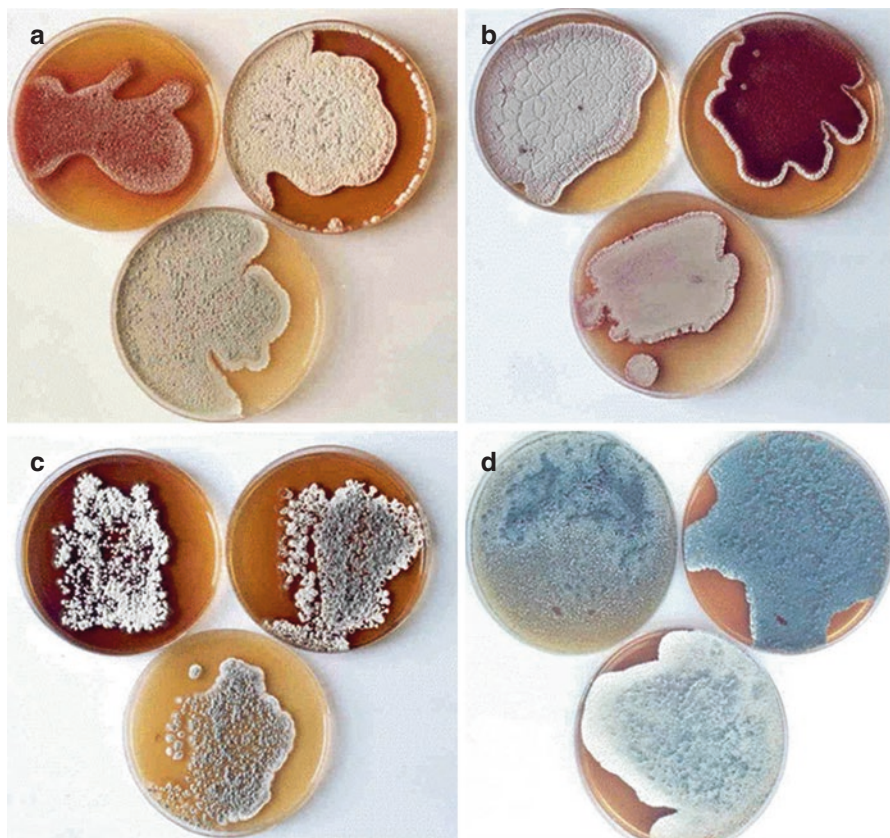
The colonies of Actinobacteria often impress by their variety of colors, especially within the substrate mycelium (see Fig. 11.1). For this pigmentation often mixtures of pigments are responsible. The most common pigments are: Carotenoids (*Actinoplanes*, *Micromonospora*), prodigiosins (*Actinomadura*, *Streptomyces*), naphthochinones (*Streptomyces*, e.g. protoactinorhodin), anthracycline-glycosides (*Streptomyces*, e.g.  $\beta$ -rhodomycin), phenozacinones (*Streptomyces*, e.g. actinomycine), diaza diphenochinone (*Arthrobacter*, *Corynebacterium*, e.g. nicotinblue), and diaza-indophenole (*Arthrobacter*, *Streptomyces*, e.g. indochrom). As the pigmentation of the substrate mycelium is one of the simple to detect characters it is often used even this character is influenced by much more factors than the color of the aerial mycelium, many of the pigments are secondary metabolites and their production varies also within one species. Pigment production is also depending on culture conditions and light. It is not possible to identify the responsible pigments exclusively on the basis of their color. For using pigments as a taxonomic marker the chemical structure has to be identified. Account must be taken that chemically different pigments can express the same color that a pigment can change its color basing on the pH, and that the color can be caused by a mixture of different pigments (Fig. 11.1).

In Table 11.1 an overview on the pigment characterization in Actinobacteria, mainly *Streptomyces* (basing on Kutzner et al. 1986) is given.

Exopigments influence the perception of endopigments. Therefore it is important to consider both. PH-sensitive pigments can be made visible by the addition of some droplets of 0.05 N NaOH or 0.05 N HCl to the agar plates (Shirling and Gottlieb 1966).

### 11.1.2 Microscopic Analyses

Within the class Actinobacteria typical bacterial cell forms like coccoid or rod shaped single cells, as described for *Micrococcus* or *Arthrobacter*, can be found. However, many species also grow in branched mycelia. Most of these mycelia forming genera can be differentiated on basis of their morphology, as described

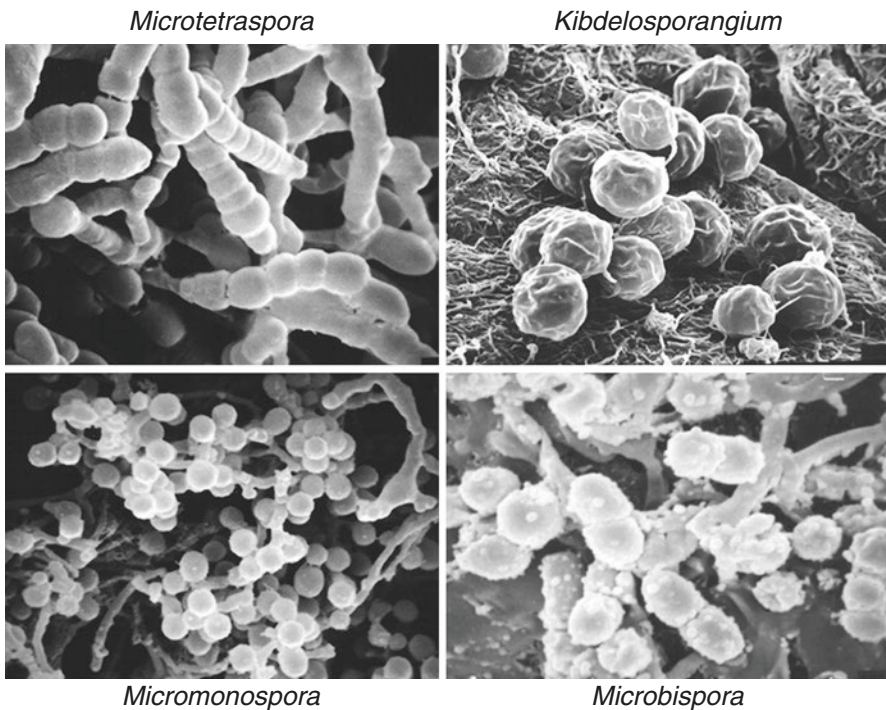


**Fig. 11.1** Color of aerial and substrate mycelium as well as soluble pigment formation in some *Streptomyces* species. The strains are cultured on GYM medium (upper left), ISP 2 (upper right), and ISP 3 (lower) for 14 days at 28°C. (a) *Streptomyces bellus*, (b) *S. californicus*, (c) *S. aurantiogriseus*, (d) *S. pharetrae*

for fungi. Not only well-developed substrate mycelium but also aerial mycelium with differentiation in spore chains, sporangia, or single spores occurs. These morphological features are used for taxonomic classification for a long time and are still characteristic for many species (Miyadoh and Gakkai 1997). Some genera had been named because of their morphological features as in the case of the monosporic *Micromonospora* (Cross 1981) or because of the spore pairs produced by *Microbispora* and *Planobispora*. Nowadays it is known from other genera that a morphological marker is not necessarily present in all species. For example, not all species of the genus *Microtetraspora* have 4 spores in one chain and the pseudosporangia, which has been described formerly as a characteristic of the genus *Kibdelosporangium*, can also be found in *Amycolatopsis* (Wink et al. 2004) (see Fig. 11.2).

**Table 11.1** Endo- and exopigment characterization in Actinobacteria

Color	Representatives
Orange–dark red (mainly endopigment)	<i>Micromonospora coerulea</i> , <i>Streptomyces cinnabarinus</i> , <i>S. griseoruber</i>
Red–blue–violet (mainly endopigment)	<i>Streptomyces californicus</i> , <i>S. cinereoruber</i> , <i>S. purpurascens</i>
Red violet–blue (endo – and/or exopigment)	<i>Streptomyces coelicolor</i> , <i>S. cyaneus</i> , <i>S. lateritius</i> , <i>S. violaceoruber</i>
Yellow orange–yellow green (endo- and exopigment)	<i>Streptomyces atroolivaceus</i> , <i>S. canaries</i> , <i>S. galbus</i> , <i>S. tendae</i>
Grey blue (mainly endopigment)	<i>Actinomadura rubrobrunnea</i> , <i>Microtetraspora glauca</i>
Green–green olive (endo- and exopigment)	<i>Streptomyces nigrifaciens</i> , <i>S. viridochromogenes</i>
Green (endo- and exopigment)	<i>Streptomyces geysiriensis</i> , <i>Nonomuraea salmonea</i>
Red brown–dark brown (endo- and exopigment)	<i>Streptomyces badius</i> , <i>S. phaeochromogenes</i> , <i>S. eurythermus</i>
Grey brown–black (endo- and/or exopigment)	<i>Streptomyces alboniger</i> , <i>S. hygrosopicus</i> , <i>S. violaceoniger</i>



**Fig. 11.2** Typical morphology of members of the genera *Microtetraspora* (*M. niveoalba*  $\times$  7500) having short spore chains, but not limited to four spores, *Kibdelosporangium* (*K. aridum*  $\times$  5000) forming pseudosporangium, *Micromonospora* (*M. sp.*  $\times$  7500) with single spores and *Microbispora* (*M. rosea* subsp. *rosea*  $\times$  10,000) with spore pairs in SEM

### 11.1.2.1 Formation of Sporangia

A number of genera form sporangia within the aerial mycelium, like *Streptosporangium* and *Spirillospora*, or directly on the substrate mycelium like *Actinoplanes* and *Pilimelia* (Bland and Couch 1981). These sporangia harbor many single spores which are arranged in different forms of spore chains within the sporangium envelop. In the genera *Planomonospora* and *Planobispora* small sporangia, carrying one or two spores, can be found. These morphological features can be detected well under light microscope, but obviously more details become visible using a scanning electron microscope (SEM; Figs. 11.2, 11.3 and 11.4) (Vobis 1985).

### 11.1.2.2 Formation of Spore Chains and the Spore Surface Ornamentation

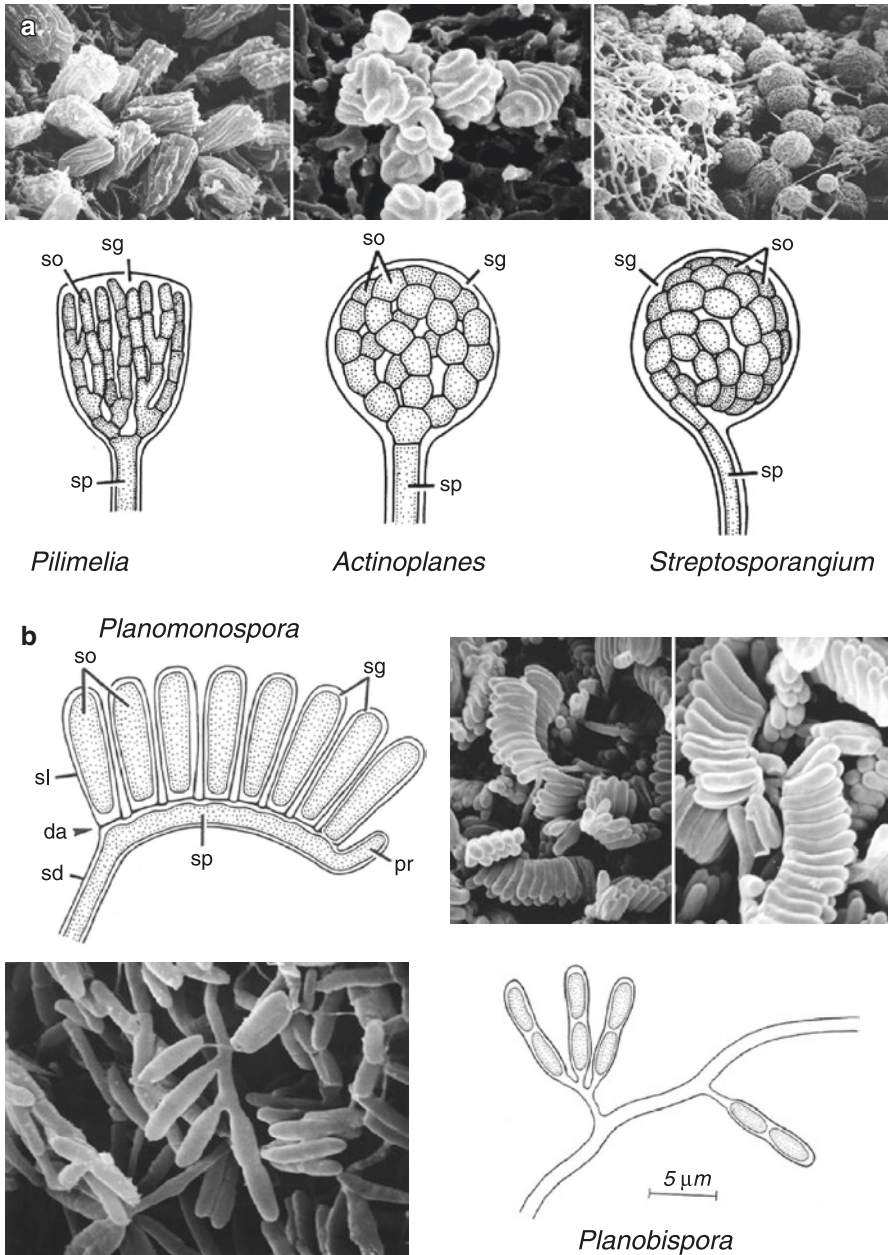
The morphology of spore chains is an important taxonomic marker for identification especially within the genus *Streptomyces* (Waksman 1961; Williams and Wellington 1981) (Table 11.2). In the ISP project for example, spore chain morphology has been described for all species and also many other authors based their species concept on this morphological character (see Table 11.3) (Hütter 1967; Shinobu 1958; Pridham et al. 1958). Different morphological spore chain types are shown in Fig. 11.4. Most authors use the following characterization: Rectiflexibilis, retinaculiaperti, spirals, or verticillus. Rectiflexibilis or RF includes spore chains which are straight line (Rectus) or wavy (Flexibilis). Retinaculum-Apertum or RA are spore chains shaped like a hook or a loop. Also spirals with one to two windings with a loose diameter belong to this type. The verticillus type was the eponym for the separate genus *Streptoverticillium* (Baldacci et al. 1966) for many years, until Witt and Stackebrandt (1990) proposed the transfer of the whole genus to *Streptomyces*, on the basis of high 16S rRNA sequence similarity. Within the verticillus type four subtypes can be differentiated: Monoverticillus (MV) with primary whorls, without spirals, monoverticillus-spira (MIV-S), also with primary whorls but with spirals, biverticillus (BIV), primary and secondary whorls without spirals, and biverticillus-spira (BIV-S), also primary and secondary whorls but with spirals.

Beside the morphology of the spore chain the ornamentation of the spore surface is often used as characteristic, especially within the genus *Streptomyces* (see also Table 11.2) (Dorokhova et al. 1969; Henssen 1970; Locci 1971; Tresner et al. 1961; Wildermuth 1972; Williams et al. 1972). The observation of the ornamentation is carried out with scanning electron microscopy. Beside the classical types smooth, hairy, spiny, and warty examples for additional characters, knobby and rugose, are shown in Fig. 11.5.

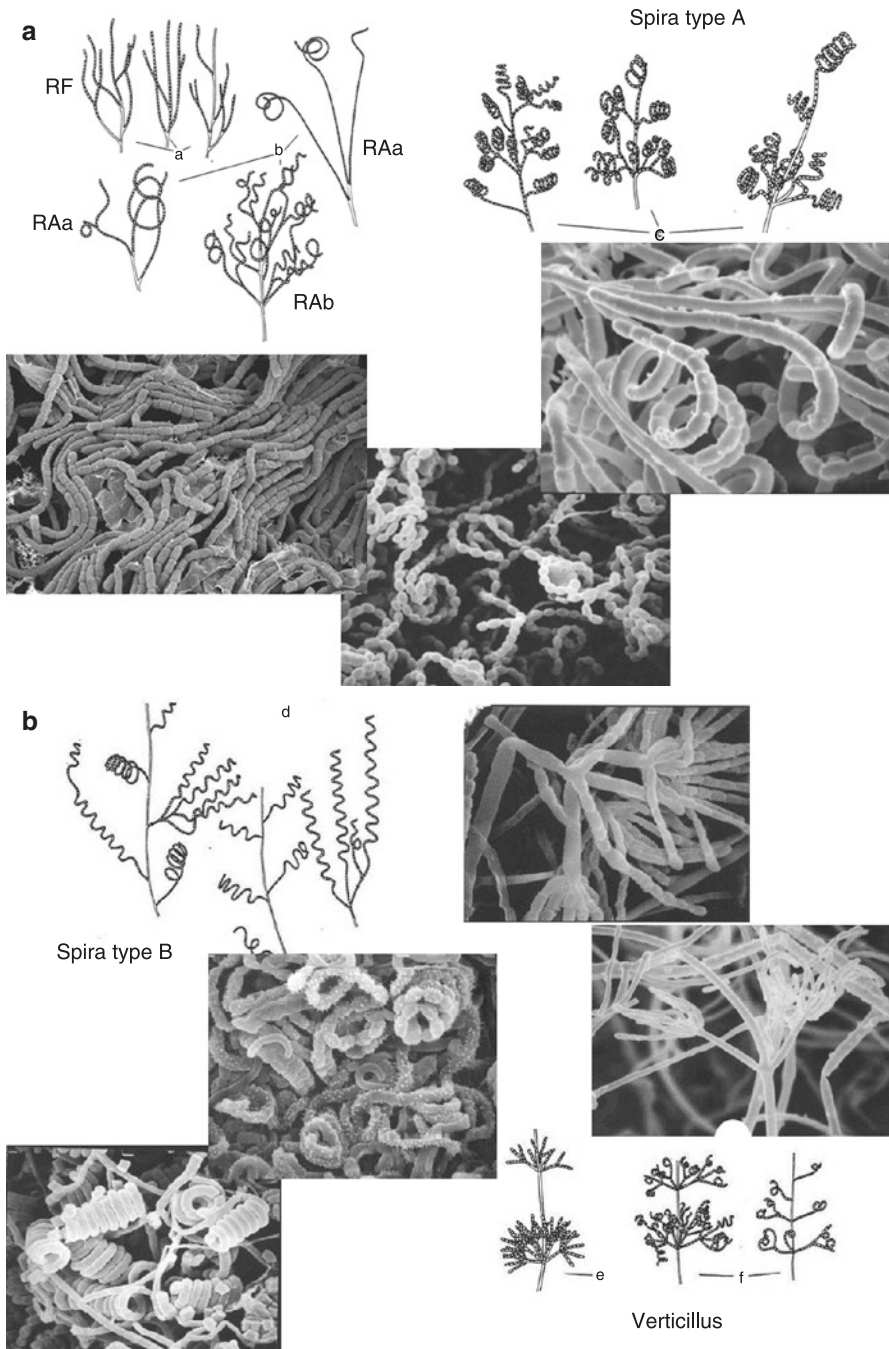
### 11.1.2.3 Light Microscopic Characterization

For light microscopic studies of Actinobacteria objectives with a long distance between objective and object can be used. Overgrown agar plates can directly be used as preparations. Therefore strains were cultivated on agar media as described for morphological characterization within this chapter. For light microscopy mainly





**Fig. 11.3** Sporangia formation in Actinobacteria. (a) Typical sporangia of *Pilimelia*, *Actinoplanes* and *Streptosporangium* in SEM and schematic drawing (so—spores, sg—mature sporangium, sp.—sporangiophore). (b) Sporangia of *Planomonospora parontospora* (sd—hyphal sheath, sp.—sporangiophore, pr—apical primordium, sg—sporangium, sp.—spore, sl—sporangiophore, da—diaphragm) and of *Planobispora rosea* (drawing and SEM picture are in parallel). (All pictures are taken from Wink Compendium of Actinobacteria or modified from Miyadoh and Gakkei 1997)



**Fig. 11.4** Spore chain morphology in *Streptomyces* in SEM and schematically (basing on Wink Compendium and Hütter 1967). (a) *Rectus flexibilis*, *Retinaculum apertum* and *Spira* type A; (b) *Spira* type B and *Verticillus*

**Table 11.2** Morphological characters within members of the genus *Streptomyces* (Williams et al. 1989)

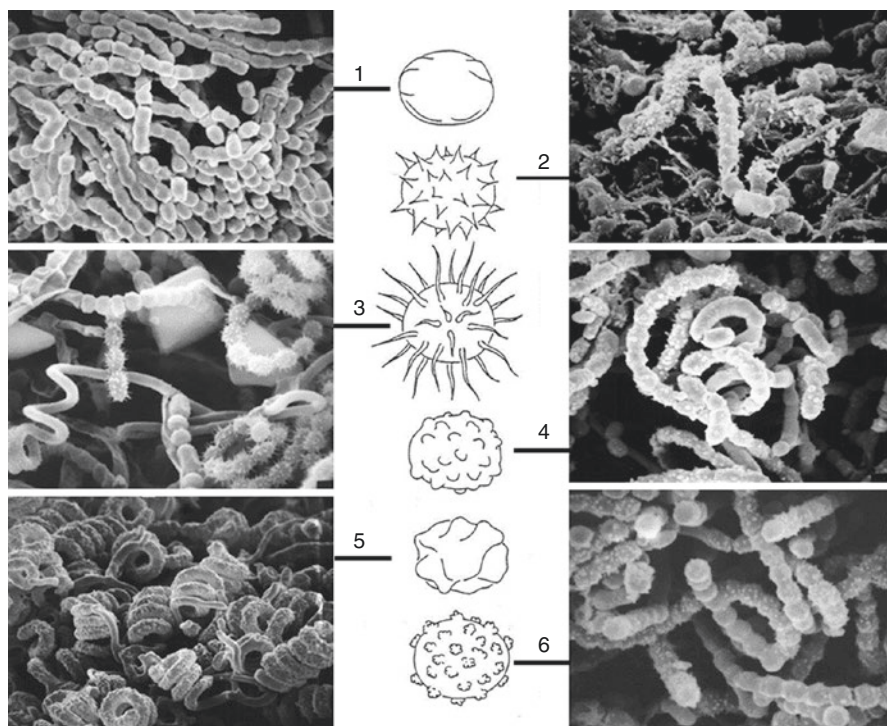
Characters	Character state
1. Spore chain morphology	Rectiflexibilis, retinaculiaperti or spirals
2. Spore surface ornamentation	Smooth, warty, hairy or rugose
3. Other morphological features	Fragmentation of substrate mycelium, sclerotia formation, sporulation in substrate mycelium
4. Color of spore mass	Blue, grey, green, red violet, white or yellow
5. Pigmentation of substrate	Yellow-brown (no distinctive pigment), blue, mycelium (colony reverse) green, red-orange or violet, pH sensitivity
6. Diffusible pigments	Yellow-brown, blue, green, red-orange or violet, pH sensitivity of pigments
7. Melanin pigment production	On peptone-yeast extract-iron and tyrosine agar

**Table 11.3** Use in morphological characters for species determination within the genus *Streptomyces* in history

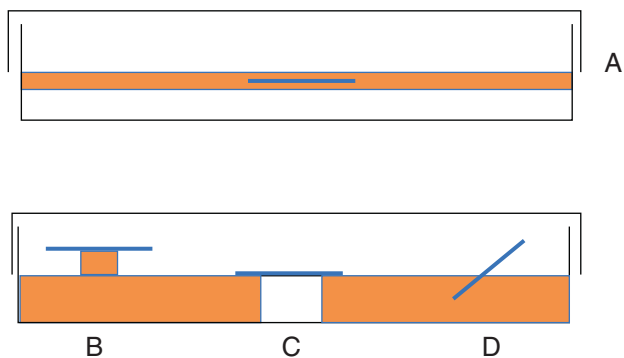
Investigator	Criterion or criteria used
Krainsky (1914)	Size of single-spore colonies
Waksman and Curtis (1916)	Proteolysis and formation of soluble pigment
Drechsler (1919)	Morphology of sporophores
Waksman (1919)	Formation of soluble pigment
Jensen (1930)	Formation of soluble pigment
Duché (1934)	Cultural characteristics
Krasilnikov (1941, 1949)	Morphology of sporophores
Baldacci et al. (1954)	Color of vegetative mycelium
Hesseltine et al. (1954)	Spore color and morphology of sporophores
Gauze et al. (1957)	Color of aerial and vegetative mycelium
Shirling and Gottlieb (1966)	Criteria of the ISP project

media with low turbidity were used. If normal light microscopic objectives are used, a number of methods using h cover plates can be applied (see Fig. 11.6).

1. The double layer method: Here in the petri dish a sterile cover plate is placed on a layer of water agar (1% agar in distilled water) and then covered again with a thin layer of the cultivation medium. The inoculum of the targeted strain is scratched into the agar so that it can grow up to the cover plate.
2. Agar block method: Here a small agar plug is cut out of the growth medium and is placed on top of it. The surface of the block is inoculated with a spore suspension of the actinobacterial strain and then covered with a sterile cover plate.



**Fig. 11.5** Spore ornamentation within the genus *Streptomyces* taken with SEM and shown schematically (based on Wink Compendium 2016 or modified after Miyadoh and Gakkei 1997). 1—smooth, 2—spiny, 3—hairy, 4—warty, 5—rugose, 6—verrucose



**Fig. 11.6** Preparation for light microscopy (details see text)

3. The furrow method: A small furrow is cut out of the agar and the walls are inoculated with the spore suspension, afterwards the furrow is covered by a cover plate.
4. The cover plate method: A sterile cover plate is placed slanted into the agar which is inoculated with the actinobacterial strain. This strain will then grow on the surface of the cover plate.

All these methods have in common that after incubation the cover slants will be collected and used for microscopy of the grown surface on top. The following characteristics can be analyzed: Spore chains and their morphology (Rf, RA, S, V), sporangia or single spores, fragmentation of aerial or substrate.

#### **11.1.2.4 Scanning Electron Microscopy**

Preparations of the strains can, for example, be performed using a modified method of Vobis and Kothe (1985) described by Wink (2003). The strains have to be cultivated on ISP 2 or ISP 3 medium or any special agar required for growth and differentiation at 28°C (or any other temperature required) over a period of 10 to 14 days. Out of these plates 1 cm<sup>2</sup>-pieces have to be cut and incubated in a solution of 4% glutaraldehyde in water for 24 h or longer. After washing with water (five times, 10 minutes each), the samples have to dehydrate by incubation in 2-methylglycerol (three times, 10 minutes each). The methyl glycerol has to be replaced by dry acetone (three times, 10 minutes each) and the samples have to be dried at the critical point using CO<sub>2</sub>. Then the samples have to be fixed on a brass cylinder and covered with gold using the sputtering system. This method can be used for all strains which form stable mycelium and are connected to the agar.

Strains which grow in single cells like coryneform bacteria have to be fixed on lysine coated glass plates. Therefore the glutaraldehyde-fixed samples have to be washed for 10 minutes in 30% ethanol, then for 10 minutes in 60% ethanol, and at least for 10 min in 90% ethanol. The suspension has to be decanted and the cells have to be transferred to the lysine plate and dried for a minute with air. Then the plate has to be washed two times for 10 minutes in pure ethanol. These samples have to also be dried by using the critical point drying method with CO<sub>2</sub>, fixed on brass cylinders and covered with gold.

### **11.1.3 Media Compositions for Growth Characterization**

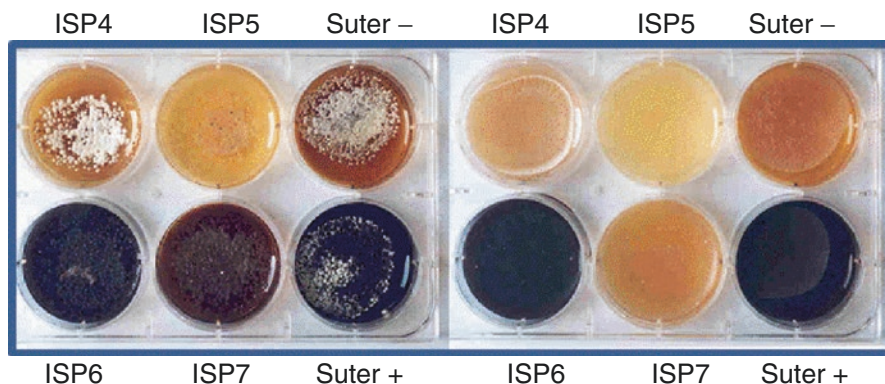
See Tables 11.4, 11.5, and 11.6

---

## **11.2 Physiological Investigation**

### **11.2.1 Formation of a Melanoid Pigment**

A lot of *Streptomyces* species, but also members of other genera of the Actinobacteria, form dark brown to black pigments on media containing tyrosine. The amino acid



**Fig. 11.7** Two examples of production of melanoid pigment in *Streptomyces* (*S. hawaiiensis*—left and *S. aurantiogriseus*—right) Wink Compendium (2016)

tyrosine is a component of peptones added to the media, but it can also be found in complex media with meat extract. The enzyme tyrosinase is responsible for the first step in the melanin biosynthesis and is only produced by melanin positive strains. Four different media can be used for the melanin characterization of Actinobacteria (Nitsch and Kutzner 1968). The first two (ISP6 and ISP7) were described by Shirling and Gottlieb (1966) for the ISP project and the third and fourth are mentioned in Kutzners (1981)’s manual of Actinomycetes. ISP6 is a peptone iron agar with yeast extract as a complex C-source, while ISP7 is a synthetic medium containing tyrosine. The last two media variations are based on a synthetically medium from Suter (1978), used with and without tyrosine. The pigment production of test strains is controlled after 5, 10, and 14 days and recorded by using “+” for a visible colony formation or “-“for none. In some cases an additional “(+)” is used if a brown exopigment is visible which might be correlated with melanin (Fig. 11.7). With this evaluation each strain can be assigned into one of four clusters, which are displayed in Tables 11.4, 11.5, and 11.6:

### 11.2.2 The Utilization of Carbon Sources

The ability to utilize different carbon sources plays an important role in bacterial species differentiation and therefore in characterizing Actinobacteria as well (Benedict et al. 1955; Zähler and Ettlinger 1957; Pridham and Gottlieb 1948; Nitsch and Kutzner 1973).

During testing ten different compounds are tested, based on the method of Shirling and Gottlieb (1966) under the use of the basal agar (Table 11.7):

10% stock solutions of the mentioned carbon sources have to be prepared (using demineralized water), sterilized by filtration and added to the basal medium after cooling it down to 60°C (after autoclaving). The final concentration has to be adjusted to 1%. During further testing, a plate containing only pure basal medium

**Table 11.4** The ISP media (Shirling and Gottlieb 1966) and Gym medium (modified ISP 2)

ISP2/ Yeast malt agar		ISP3/ Oat meal agar	
Malt extract	10.0 g/l	Oatmeal (Quaker white oats)	20.0 g/l
Yeast extract	4.0 g/l	Agar	18.0 g/l
Glucose	4.0 g/l	Deionized water	1000 ml
Agar	15.0 g/l	Trace salt solution	1 ml
Deionized water	1000 ml		
pH before sterilization	7.0	pH before sterilization	7.2
		1. Filter through cheese cloth after sterilization 2. Add trace salt solution	

ISP 4		ISP5	
Soluble starch	10.0 g/l	L-asparagine	1.0 g/l
(NH <sub>4</sub> ) <sub>2</sub> SO <sub>4</sub>	2.0 g/l	Glycerol	10.0 g/l
K <sub>2</sub> HPO <sub>4</sub>	1.0 g/l	K <sub>2</sub> HPO <sub>4</sub>	1 g/l
MgSO <sub>4</sub> ×7H <sub>2</sub> O	1.0 g/l	Trace salt solution	1 ml/l
NaCl	1.0 g/l	Agar	20 g/l
CaCO <sub>3</sub>	2.0 g/l	Deionized water	1000 ml
Agar	20.0 g/l	pH before sterilization	7.2
Deionized water	1000 ml		
pH before sterilization	7.3		

Trace salt solution ISP3		Trace salt solution ISP5	
FeSO <sub>4</sub> × 7H <sub>2</sub> O	0.1 g	1.0 g FeSO <sub>4</sub> × 7H <sub>2</sub> O	1.0 g
MnCl <sub>2</sub> × 4H <sub>2</sub> O 0.1 g	0.1 g	1.0 g MnCl <sub>2</sub> × 4H <sub>2</sub> O	1.0 g
ZnSO <sub>4</sub> × 7H <sub>2</sub> O 0.1 g	0.1 g	1.0 g ZNSO <sub>4</sub> × 7H <sub>2</sub> O	1.0 g
Deionized water	100 ml	Deionized water 100 ml	100 ml

ISP 6/Peptone iron agar <sup>a</sup>		ISP7/Oat meal agar <sup>a</sup>	
Peptone	15.0 g/l	Glycerol	15 g/l
Proteose peptone	5.0 g/l	L-tyrosine	0.5 g/l
Ferric ammonium citrate	0.5 g/l	L-asparagine	1.0 g/l
Sodium glycerophosphate	1.0 g/l	K <sub>2</sub> HPO <sub>4</sub>	0.5 g/l
Sodium thiosulfate-5-hydrate	0.126 g/l	NaCl	0.5 g/l
Yeast extract	1.0 g/l	FeSO <sub>4</sub> × 7H <sub>2</sub> O	0.01 g/l
Agar	20 g/l	Trace salt solution (5343)	1.0 ml/l
Deionized water	1000 ml	Agar	20.0 g/l
pH before sterilization	7.2	Deionized water	1000 ml
		pH before sterilization	7.3

GYM-Medium	
Glucose	4.0 g/l
Yeast extract	4.0 g/l
Malt extract	10.0 g/l

**Table 11.4** (continued)

GYM-Medium	
CaCO <sub>3</sub>	2.0 g/l
Agar	12 g/l
Deionized water	1000 ml
pH before sterilization	7.2
Using KOH to adjust pH	

<sup>a</sup>Melanoid pigment**Table 11.5** Classification of actinomycetes into four different clusters based on colony formation and melanin production on ISP6, ISP7, and Suter media

ISP6	ISP7	Suter		Cluster
		With Tyrosine	Without Tyrosine	
+	+	+	–	3
+	+	–	–	2
–	–	+	–	1
–	–	–	–	0

**Table 11.6** Composition of the Suter medium (Suter 1978)

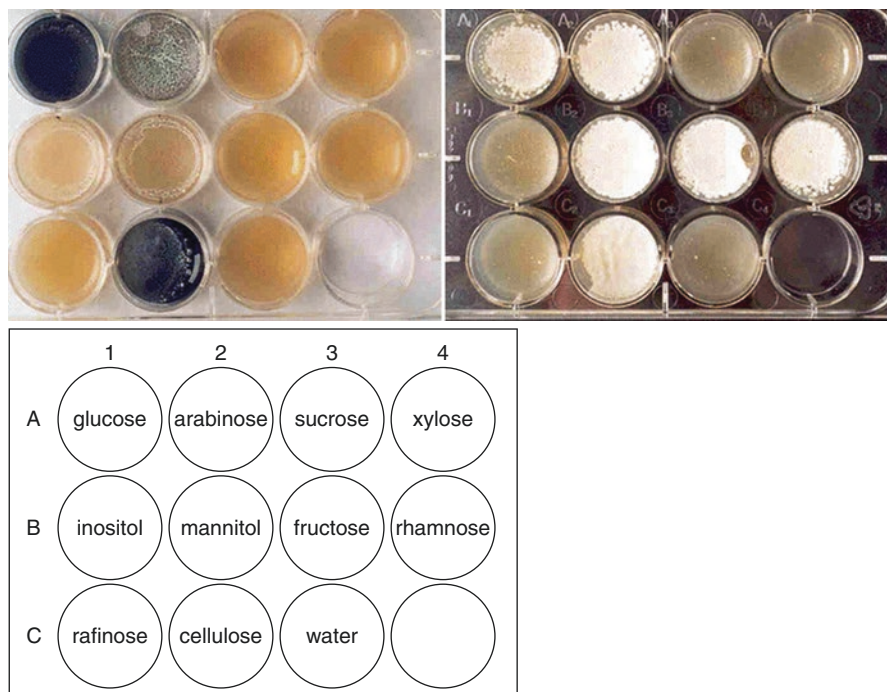
Synthetically Suter medium—production of melanoid pigment	
Glycerol	15.0 g/l
Tyrosine	1.0 g/l
L-arginine	5.0 g/l
L-glutamic acid	5.0 g/l
L-methionine	0.3 g/l
L-isoleucine	0.3 g/l
K <sub>2</sub> HPO <sub>4</sub>	0.5 g/l
MgSO <sub>4</sub> × 7H <sub>2</sub> O	0.2 g/l
Trace element solution 2 (5341)	1.0 ml/l
Agar	
pH before sterilization	
-Control medium is prepared without tyrosine	

Trace salt solution 5341	
FeSO <sub>4</sub> × 7H <sub>2</sub> O	10.0 g/l
MnSO <sub>4</sub> × 7H <sub>2</sub> O	40.0 g/l
ZnSO <sub>4</sub> × 7H <sub>2</sub> O	10.0 g/l
CuSO <sub>4</sub> × 5H <sub>2</sub> O	10.0 g/l
CaCl <sub>2</sub> × 2H <sub>2</sub> O	10.0 g/l



**Table 11.7** Different carbon sources used for the characterization of Actinomycetes

Carbon source	Abbreviation	Carbon source	Abbreviation
Arabinose	Ara	Mannitol	Man
Cellulose	Cel	Raffinose	Raf
Fructose	Fra	Rhamnose	Rha
Glucose	Glu	Sucrose	Suc
(Meso) inositol	Ino	Xylose	Xyl



**Fig. 11.8** The utilization of carbon resources in *Streptomyces*. *Upper*—*Streptomyces albobifaciens* and *S. albobinaceus*. *Lower*—position of the different carbon sources in the 12 well plate (Wink Compendium 2016)

and water should be used as negative control while one with glucose should serve as positive control (Fig. 11.8). The evaluation has to be carried out using the following scheme (Table 11.8):

### 11.2.3 Resistance to Sodium Chloride

The resistance to sodium chloride is a helpful tool in differentiating between all species of Actinobacteria, not only between those of the marine or halophilic habitats. The resistance test is carried out by analyzing the growth on basal medium

**Table 11.8** Growth classification in carbon source testing and basal medium (Shirling and Gottlieb 1966)

Observed growth is:	Symbol
Worse than negative control	–
Better than in negative control but not as good as in positive control	(+)
Similar to positive control	+
Better than positive control	++

## Basal medium for carbohydrate utilization

(NH <sub>4</sub> ) <sub>2</sub> SO <sub>4</sub>	2.64 g/l	1. Medium is solved in 900 ml deionized water and autoclaved
KH <sub>2</sub> PO <sub>4</sub>	2.38 g/l	2. Carbohydrates solutions with 10% of the 10 carbohydrates (2.4) are prepared
K <sub>2</sub> HPO <sub>4</sub>	4.31 g/l	3. After autoclaving, 100 ml of one of the sterile filtrated carbohydrate solutions are added (2.4)
MgSO <sub>4</sub> × 7H <sub>2</sub> O	1.0 g/l	
Agar	15.0 g/l	
Trace element solution three	1.0 ml/l	
Deionized water	1000 ml	
pH before sterilization	7.3	

## Trace element solution

CuSO <sub>4</sub> × 5H <sub>2</sub> O	0.64 g/l
FeSO <sub>4</sub> × 7H <sub>2</sub> O	0.11 g/l
ZnSO <sub>4</sub> × 7H <sub>2</sub> O	0.15 g/l
MnCl <sub>2</sub> × 4H <sub>2</sub> O	0.79 g/l
Deionized water	1000 ml

**Table 11.9** Medium composition for sodium chloride tolerance test (Shirling and Gottlieb 1966)

Sodium chlorite tolerance	
Casein peptone	10.0 g/l
Yeast extract	5.0 g/l
Agar	20 g/l
Deionized water	1000 ml
pH before sterilization	7.0

with 0, 2.5, 5.0, 7.5, and 10.0% of sodium chloride. After five to ten days of incubation the highest salt concentration at which growth is possible. In most cases there are no clear-cut borderlines between growth and no growth. Often there is good growth and formation of aerial mycelium without sodium chloride, while with increasing salt concentration the aerial mycelium is lost at the expense of a better substrate mycelium formation, until this mycelium formation comes to a stop as well (Table 11.9).

**Table 11.10** Medium composition for the evaluation of chitin degradation

Medium for chitin degradation	
Chitin, powdered	4.0 g/l
K <sub>2</sub> HPO <sub>4</sub>	0.7 g/l
KH <sub>2</sub> PO <sub>4</sub>	0.3 g/l
MgSO <sub>4</sub> × 7H <sub>2</sub> O	0.5 g/l
FeSO <sub>4</sub> × 7H <sub>2</sub> O	0.01 g/l
ZnSO <sub>4</sub> × 7H <sub>2</sub> O	0.001 g/l
MnCl <sub>2</sub> × 4H <sub>2</sub> O	0.001 g/l
Agar	12.0 g/l
pH before sterilization	8.0

### 11.2.4 Degradation of Chitin

Many Actinobacteria are able to grow on chitin as the only C- and N- source, while only a small number of other bacteria is able to do so (Jeunilaux 1955; Kuznetsov and Yangulova 1970; Reynolds 1954). Chitin positive organisms degrade the substrate to water soluble fragments and form a clear halo around the colony on the turbid medium. The strains have to be cultivated on the medium which is described afterwards and the formation of clear zones in the surrounding of the colony has to be observed (Table 11.10).

### 11.2.5 Test on Temperature and pH Optimum

For the detection of the optimal growth temperature a number of plates containing a sufficient growth medium for the according strain have to be inoculated and incubated at different temperatures (e.g., room temperature, 30, 37, and 44°C). Analogue characterization method can be used for the determination of pH optimum. In this case five plates of the optimal growth medium, adjusted to different pH-values (5, 6, 7, 8 and 9), have to be prepared and inoculated at 30°C for 1 week.

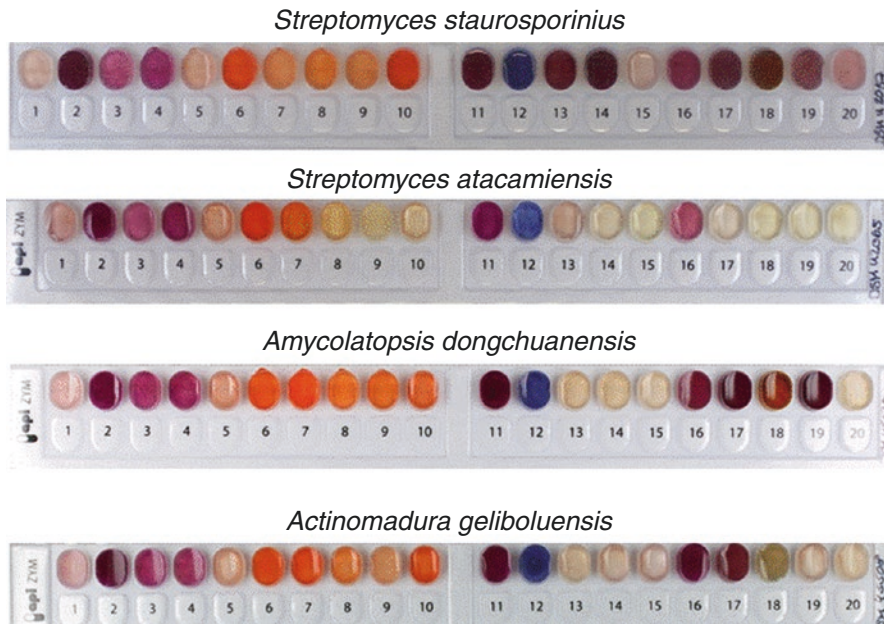
## 11.3 Biochemical Tests

### 11.3.1 Physiological Fingerprints with API® Stripes

A part of the physiological classification is the detection of enzymes which are produced by the Actinobacteria. In order to detect even small enzymatic activities, BioMérieux is offering a number of stripe based identification tests of which two are used in routine description of the Actinobacteria. The general approach is to transfer a defined volume of well-grown liquid culture onto a stripe containing different wells with different substrates which, in case of an enzymatic conversion, show a visible color reaction after incubation.

**Table 11.11** Enzymatic activities tested by the API Coryne system

Test	Reaction	Test	Reaction
Nit	Nitrate reduction	Pyz	Pyrazinamidase
PyrA	Pyrrolidonyl arylamidase	Pal	Alkaline phosphatase
Gur	Beta glucuronidase	Gal	Beta galactosidase
Glu	Alpha glucosidase	Nag	N-acetyl-beta glucosamidase
Esc	Esculin (beta glucosidase)	Ure	Urease
Gel	Gelatine (hydrolysis)		



**Fig. 11.9** Api Zym from different Actinobacteria (Wink Compendium 2016)

The first system used is the “API Coryne,” a test kit especially for the Propionibacterineae, Micrococcineae, and Corynebacterineae (MacFaddin 1980). The included tests and reactions are listed in Table 11.11:

The other system in use is the API Zym test stripe, a simple rapid system for the detection of bacterial enzymes (Humble et al. 1977) which has been successfully used for identification of Actinomycetaceae and related bacteria in the past (Kilian 1978) (Fig. 11.9). The following parameters are tested (Table 11.12).

For using the API tests, cultures have to be grown in shaking flasks for up to 2 weeks, depending on the strain. In most cases the cultures have to be diluted with water before testing because the biomass or produced exopigments hold the potential to interfere with the color reactions in the test tube. If a strain grows in big agglomerates, it has to be homogenized with an ultra turrax. The following procedure is due to the manufacturer’s manual:

**Table 11.12** Enzymatic activities tested by the API Zym system

No.	Enzyme	Substrate
2	Phosphatase alcaline	2-naphthyl phosphate
3	Esterase (C 4)	2-naphthyl butyrate
4	Esterase lipase (C 8)	2-naphthyl caprylate
5	Lipase (C 14)	2-naphthyl myristate
6	Leucine arylamidase	L-leucyl-2-naphthylamide
7	Valine arylamidase	L-valyl-2-naphthylamide
8	Cystine arylamidase	L-cystyl-2-naphthylamide
9	Trypsin	<i>N</i> -benzoyl-DL-arginine-2-naphthylamide
10	Chymotrypsin	<i>N</i> -glutaryl-phenylalanine-2-naphthylamide
11	Phosphatase acid	2-naphthyl phosphate
12	Naphthol-AS-BI-phosphohydrolase	Naphthol-AS-BI-phosphate
13	Galactosidase	6-Br-2-naphthyl-D-galactopyranoside
14	Galactosidase	2-naphthyl-D-galactopyranoside
15	Glucuronidase	Naphthol-AS-BI-D-glucuronide
16	Glucosidase	2-naphthyl-D-glucopyranoside
17	Glucosidase	6-Br-2-naphthyl-D-glucopyranoside
18	<i>N</i> -acetyl-glucoseamidase	1-naphthyl- <i>N</i> -acetyl-D-glucoseaminide
19	Mannosidase	6-Br-2-naphthyl-D-mannopyranoside
20	Fucosidase	2-naphthyl-L-fucopyranoside

#### Inoculation of the API test stripes

1. Preparing an incubation box by adding 5 ml of demineralized water into the honey-combed wells in order to create a humid atmosphere
2. Record the sample reference on the elongated flap of the tray
3. Remove an API stripe from its individual packaging
4. Place the strip in the incubation box
5. Using a pipette in order to dispense 65 µl of specimen solution into each cupule
6. Close the lid and incubate generally from 4 to 4.5 h at 37°C
7. Do not expose the strip to bright light
8. After incubation add one drop of ZYM A, and one drop of ZYM B reagent to each cupule

Let the color develop at least for five minutes.

## 11.4 Compendium of Actinobacteria

The Compendium of Actinobacteria is an electronic manual including the important bacterial groups of the actinomycetes compiled by PD Dr. Joachim Wink at the HZI-Helmholtz-Centre for Infection Research, Braunschweig (joachim.wink@helmholtz-hzi.de).

The species descriptions include the documentation of the colony growth in pictures as well as the microstructure by scanning electron microscopy. About 230 species belonging to more than 190 genera are described in the current version which will be emended every year.

The microorganisms have been cultivated and characterized in the laboratories of Sanofi-Aventis Germany and the Helmholtz-Centre for Infection Research during the last 20 years. The work is carried out in a strong collaboration with the DSMZ and its researchers. The methods for the taxonomic description of the Actinobacteria are documented in a separate PDF file on the homepage, also a PDF file with links to all single PDF files of the compendium—sorted by species name—and with links to the relevant DSM numbers can be downloaded (Fig. 11.10 and Table 11.13).

<https://www.dsmz.de/bacterial-diversity/compendium-of-actinobacteria.html>

---

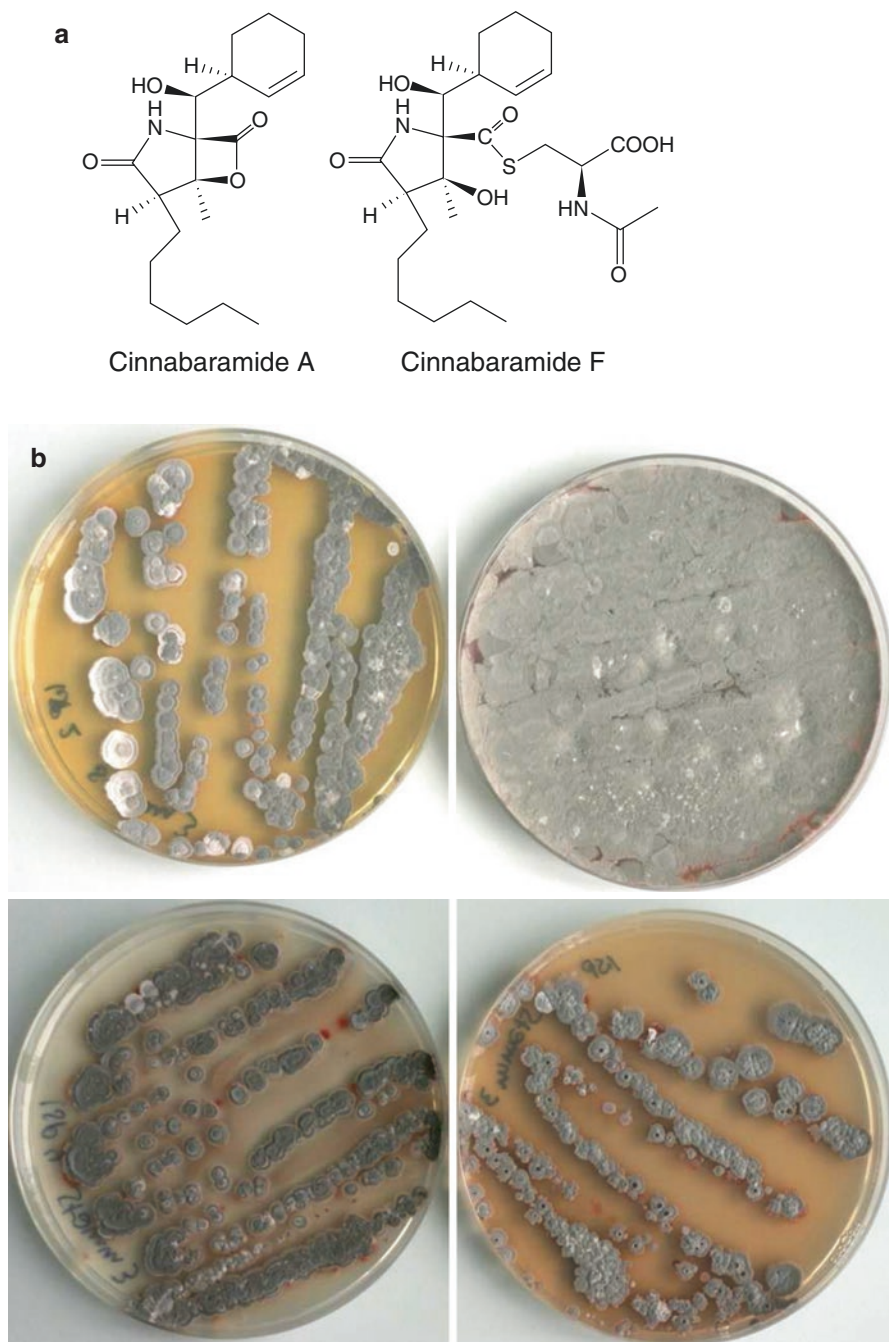
## 11.5 Genomic Analysis

Genomes of Actinobacteria have a size ranging from 1.93 MB in *Bifidobacterium animalis* subsp. *lactis* to 10.15 Mb in *Streptomyces scabies*. Their genomes contain as low as 1605 protein-encoding genes in *Mycobacterium leprae* to as high as 8983 of such genes in *Streptomyces scabies*. Up to 30 biosynthetic pathways of secondary metabolites has been identified through homology searching of genes encoding proteins involved in secondary metabolism. Among all actinobacterial genera, *Streptomyces* and *Kitasatospora* from *Streptomycetaceae*, *Salinispora* and *Micromonospora* from *Micromonosporaceae*, and *Saccharopolyspora* from *Pseudonocardiaceae* regularly possess more than 20 gene clusters for secondary metabolite production and dedicate more than 5% of their entire coding ability for this function, which can even reach to 10%. Generally, actinobacterial members with >5 Mb genomes and secondary genes positioned distal to the origin of replication gene *dnaA* are known as natural product-rich strains, whereas those containing small genomes ranging from 2–4 Mb harbors very less number of pathways for secondary metabolite production (Nett et al. 2009).

### 11.5.1 Sequence Similarity Search

DNA sequencing is considered as a beneficial tool for understanding of the biochemical nature or the biological function of the gene product. In a model organism (e.g., *Streptomyces coelicolor*), which sequences of various genes have been determined and extensive analysis has identified the functions of its genes, finding a gene with a sequence identical to that of model organism suggests a possibility that the new gene has the function similar to the model organism gene.

There are various methods for the alignment of a pair of sequences such as the diagram method or dot matrix, developed by Gibbs and McIntyre (1970) for comparing two amino acid and nucleotide sequences, and further developed through applying various filtering and color display schemes by Maizel and Lenk (1981); dynamic



**Fig. 11.10** Compendium of Actinobacteria, Excerpt of the dataset of *Streptomyces cinnabaragriseus*. (a) Secondary metabolites, (b) growth on different ISP media, (c) carbon utilization, (d) Scanning Electron Microscopy

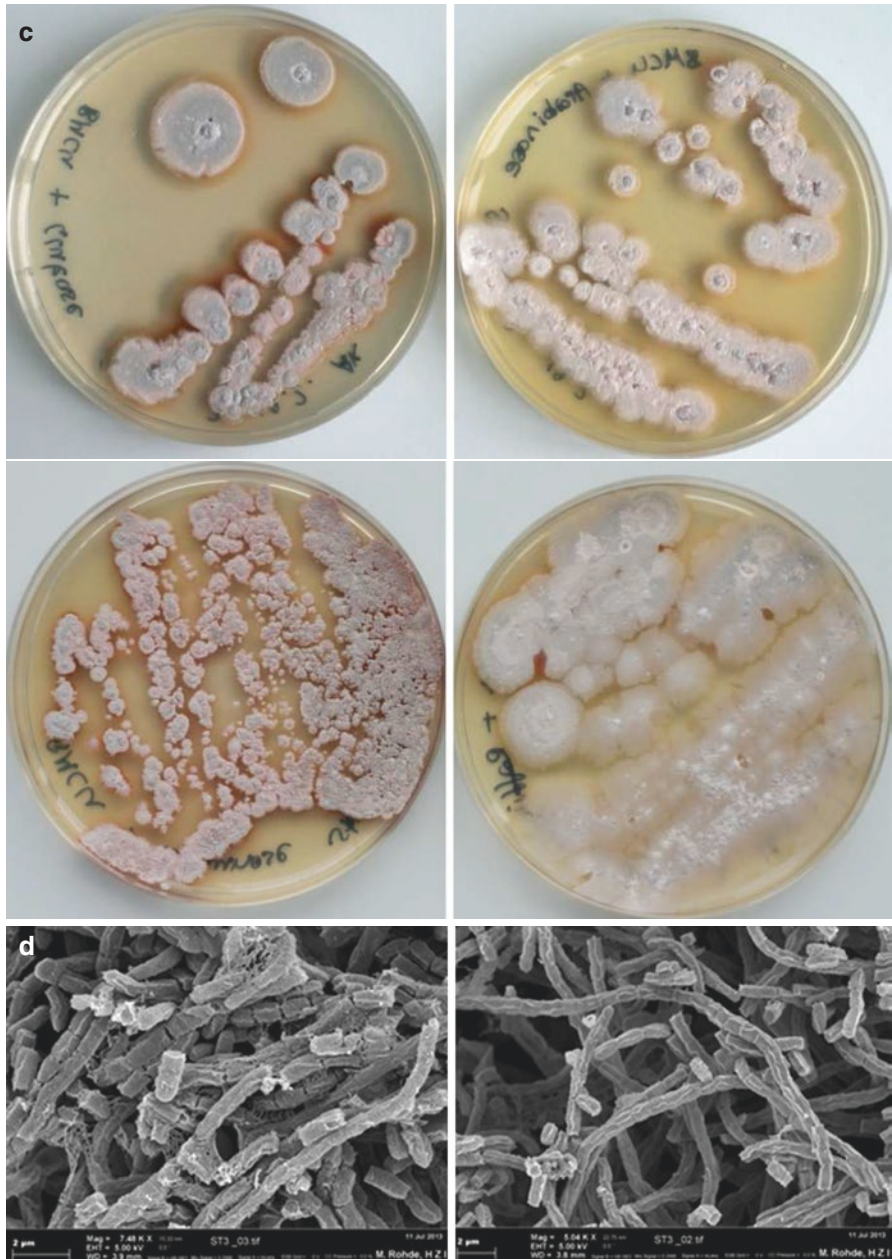


Fig 11.10 (continued)



**Table 11.13** Compendium of actinobacteria, excerpt of the dataset of *Streptomyces cinnabaragriseus*

Strain		DSM 101724
Genus		<i>Streptomyces</i>
Species		<i>cinnabaragriseus</i>
Status		Spec. nov.
Risk group		L1
References		
Author		Landwehr, W., Kämpfer, P., Schumann, P., Atasayar, E., Rohde, M., Mack, M., Martin, K., Stadler, M., Wink, J.
Title		Studies on taxonomy of members of the <i>Streptomyces cinnabarinus</i> cluster description of <i>Streptomyces cinnabaragriseus</i> spec. nov. and validation of <i>S. davawensis</i>
Journal		IJSEM
Year		In preparation
Morphology		
Agar	ISP 2—growth/G	Good
Agar	ISP 2—colony color/R	Honey yellow
Agar	ISP 2—aerial mycelium/A	Beige grey
Agar	ISP 2—soluble pigment/S	None
Agar	ISP 3—G	Good
Agar	ISP 3—R	Vermilion
Agar	ISP 3—A	Beige grey
Agar	ISP 3—S	None
Agar	ISP 4—G	Good
Agar	ISP 4—R	Red orange
Agar	ISP 4—A	Beige grey
Agar	ISP 4—S	None
Agar	ISP 5—G	Good
Agar	ISP 5—R	Black red
Agar	ISP 5—A	Beige grey
Agar	ISP 5—S	None
Agar	ISP 6—G	n.d.
Agar	ISP 6—R	n.d.
Agar	ISP 6—A	n.d.
Agar	ISP 6—S	n.d.
Agar	ISP 7—G	Good
Agar	ISP 7—R	Black red
Agar	ISP 7—A	Beige grey
Agar	ISP 7—S	Olive brown
	Sporechains/sporangia	Rf
	Spore surface	Smooth

**Table 11.13** (continued)

Strain		DSM 101724
Physiology		
Melanin		-/+
Temperature	Optimum	28
Use of carbohydrates	Glucose	+
Use of carbohydrates	Arabinose	+
Use of carbohydrates	Sucrose	+
Use of carbohydrates	Xylose	+
Use of carbohydrates	Inositol	+
Use of carbohydrates	Mannose	n.d.
Use of carbohydrates	Fructose	+
Use of carbohydrates	Rhamnose	+
Use of carbohydrates	Raffinose	+
Use of carbohydrates	Cellulose	–
Api zym	Phosphatase alkaline	+
Api zym	Esterase (C4)	+
Api zym	Esterase lipase (C8)	+
Api zym	Lipase (C14)	+
Api zym	Leucin arylamidase	+
Api zym	Valine arylamidase	+
Api zym	Cystine arylamidase	+
Api zym	Trypsin	V
Api zym	Chymotrypsin	–
Api zym	Phosphatase acid	+
Api zym	Naphthol-AS-BI-phosphohydrolase	+
Api zym	Alpha galactosidase	+
Api zym	Beta galactosidase	+
Api zym	Beta glucuronidase	–
Api zym	Alpha glucosidase	+
Api zym	Beta glucosidase	+
Api zym	<i>N</i> -acetyl-beta-glucosamidase	–
Api zym	Alpha mannosidase	+
Api zym	Alpha fucosidase	–

programming, which can detect sequence similarity that is interrupted by not very well-matched regions or that are present in one of the sequence only (e.g., deletions or insertions) (Mount 2004). In addition, there are methods allowing for aligning more number of sequences at the same time, which provide a way for search for a pattern in DNA sequences that may define an evolutionary track, processing signal in an RNA molecule or the binding site for a regulatory protein in a promoter region (Mount 2004).

FASTA and BLAST are the most commonly used programs for such similarity search. The former program, developed by Pearson and Lipman (1988), performs a quick database scan for short stretches of similar sequences between any sequence in a database and a new sequence. After breaking down each sequence into short parts a few sequence characters long, they are organized into a table indicating their location in the sequence. The similarity of regions is determined when one or more parts are present in both sequences, and especially when several parts can be joined. The latter program, developed by Altschul (1990), is available at the National Center for Biotechnology Information at the National Library of Medicine in Washington, DC Web site (<http://www.ncbi.nlm.gov/BLAST>), is the most extensively used facility for sequence analysis in the world, and provides similarity searching to all available sequences. Similar to FASTA, BLAST organizes short sequences words in each sequence under a table; however, it also discovers which of these words are most significant in order of indication of similarity between two sequences, followed by confining the scan to these words (Mount 2004).

### 11.5.2 Conventional Genome Sequencing

Assembling of sequences from fragments of DNA sequence (approximate length of 500 bp) are obtained using DNA sequencing machines as described here. DNA sequencing is begun by the purification of DNA fragments that has been cut from phage/plasmid clones or amplified by polymerase chain reaction (PCR), then they are denatured to single strands, followed by the hybridization of one of the strands to an oligonucleotide primer, which is complementary to an already known region on the DNA. During an automated process, heat-resistant *Taq* polymerase from a pool of deoxyribonucleotide triphosphates (dNTPs) is used to synthesize new strands of DNA from the end of primer in a single tube. This *Taq* polymerase contains a small amount of one of four fluorescent dichloro-rhodamine dye labeled chain-terminating nucleotides (ddNTPs). The polymerase keeps synthesizing the strands from the primer, until incorporation of ddNTP instead of dNTP, which terminates the synthesis. As the result, a nested set of labeled molecules are synthesized. The denaturing, reannealing, and synthesis processes may be recycled up to 25 times, after the removal of excess labeled ddNTPs, products are loaded on one lane of a polyacrylamide gel, and then electrophoresed. Fragments are separated based on their size, and the ladder of fragments is scanned by a laser within the sequencer for the presence of the four labeled ddNTPs, each emits light at a different wavelength band that is detectable by a digital camera. Finally the sequence of changes are plotted and read by a base-calling algorithm ddNTP (Mount 2004).

### 11.5.3 Submission of Sequences

It is recommended that all researchers submit their newly sequences directly to a valid database, for example, the DNA Databank of Japan (DDBJ; <http://www.ddbj.nig.ac.jp>); National Center for Biotechnology Information (NCBI), managing GenBank (<http://ncbi.nlm.nih.gov>); Joint Genome Institute's (JGI) Genome Portal (<http://www.genome.jgi.doe.gov>) or the European Molecular Biology Laboratory (EMBL)/EBI Nucleotide Sequence Database (<http://www.embl-heidelberg.de>). All these databases exchange their information with each other every day. To publish a new sequence, scientists receive a database accession number after probable revision of submitted entries to NCBI. However, scientists are better to verify the accuracy of sequences especially detection of chimeric sequences prior to submission to any database.

### 11.5.4 Gene Identification, Prediction and Annotation

The significance for accurate bacterial gene identifications is ever-growing with increasing rate of genome sequencing projects (Delcher et al. 1999). Sequencing of each genome produces thousands new genes that are submitted to public databases, which develop a foundation for further biological investigation of microorganisms. Gene identification is required for a number of techniques such as microarray analysis and knockout experiments (Delcher et al. 1999).

In prokaryotes, DNA sequences encoding proteins can be identified by searching in open reading frames (ORFs). Every sequence may have up to six possible reading frames, three on each strand at positions 1, 2, and 3 and proceeding in the 5' to 3' direction of a given sequence as well as the complementary sequence. The process of gene identification is facilitated in prokaryotes owing to the lack of introns, the transcription of protein encoding sequences of DNA into mRNA, and protein translation is directly done from not significantly modified mRNA. Moreover, genomes of bacteria are very gene-dense, and typically, protein-coding regions comprise more than 90% of the DNA sequence (Besemer and Borodovsky 1999; Borodovsky and McIninch 1993). In contrast with not protein-encoding ORFs, reading frames of a genomic sequence have long ORFs due to the lack of many in-frame stop codons (Mount 2004). To identify genes, newly obtained sequences are compared with well-annotated bacterial genome database by microbial gene-finding systems software. Genes are considered known if there is clear homology by the measurement of amino-acid similarity. Some of commonly used computational gene-finding software has been briefly described hereafter.

#### 11.5.4.1 Identification of Genes with GLIMMER

*Gene Locator and Interpolated Markov ModelER (GLIMMER)*, developed in 1988 (Salzberg et al. (1998) at The Institute for Genomic Research (TIGR) and improved by Delcher in 1999 (Delcher et al. 1999) and 2007 (Delcher et al. 1999, 2007), is a system opted for the identification of about 99% of all genes in microbial genomes when compared with published annotations (Delcher et al. 2007). This system can be

trained quickly using the desired genome sequence and utilizes interpolated Markov model (IMM), which is a generalization of Markov chain methods. *GLIMMER* can be applied for correct identification of genes within high GC-content genomes, such as actinobacterial genomes, which have numerous long ORFs interfering with predictions of genes due to their incorrect boundaries overlap (Delcher et al. 1999). *GLIMMER* version 3.02b is currently the latest version of the system, which is available at the website of Center for Computational Biology (CCB), Johns Hopkins University (<http://www.ccb.jhu.edu/software.shtml>). Running *Glimmer* is a two-step process: first, building a probability model of coding sequences, called an interpolated context model (ICM) is performed by the program *build-icm* from a set of training sequences obtained known genes in the genome, from long, non-overlapping ORFs in the genome, or from genes in a highly similar species/strains. Then, the *glimmer3* program is run to analyze the gene sequences and makes gene predictions. The new *Glimmer*, release 3.02b, predicts many start sites correctly, and has low false-positive rate, which results in higher accuracy in gene identification by the system.

#### 11.5.4.2 Identification of Genes with *GeneMarkS*

In 2001, *GeneMarkS* was developed by Besemer et al. It is an improved version of the gene-finding program *GeneMark.hmm*, and has prediction precision range of 83.2–94.4% on tested organisms (reference). The improved method is taking advantage of combining models of protein-coding and non-coding regions and models of regulatory sites near gene start within an iterative Hidden Markov model based algorithm (Besemer et al. 2001). The accurate translation start prediction and the refinement of protein sequence N-terminal data in this method provide the advantage of precise positioning of the upstream sequence of a gene. Consequently, sequence motifs associated with transcription and translation regulatory sites can be revealed and analyzed with better precision (Besemer et al. 2001). Currently, the latest version of gene prediction program *GeneMarkS* is 4.28 and is accessible at <http://www.exon.gatech.edu/Genemark/genemarks.cgi> with easy-working interface.

#### 11.5.4.3 Identification of Genes with *FrameD*

*FrameD* was initially developed for prediction of genes in bacterial genomes with high GC-content. The overprediction of many overlapping genes in GC-rich genomes of Actinobacteria can be occurred as most coding regions inherently induce mirror open reading frame on the reverse strand. *FrameD* is based on a weighted directed acyclic graph (DAG) model, designed in such a manner that each path in the graph represents a possible gene prediction, consistent with START and STOP codons use, and uses extended interpolated Markov models for building probabilistic models of coding sequences (Schiex et al. 2003). *FrameD* is implemented in C++ and can be found at <http://www.genopole.toulouse.inra.fr/bioinfo/FrameD/FD>, which allows users to specify the sequence and parameters, and in turn, provides gene prediction, sequence correction and translation, and has the ability to learn new models for new strains (Schiex et al. 2003). Users are provided with an option on probabilistic model whether to be estimated on existing bacterial genomes or to develop a new gene model. Additionally, the GC-content class (low or medium/high) and frameshift penalties, which reflects the sequence quality, must be determined. In a section, called

Protein similarities, users are provided with an optional choice to specify existing similarities between the protein sequence and the sequence, which is provided using “tabulated format” accessible in new versions of NCBI-BlastX program. Output parameters such as the layout of the prediction including image size, textual, graphical or both, and etc. can be controlled. *FrameD* performances have been compared to that of *GeneMarkS* and have a tendency to obtain higher sensitivity at the cost of a lower specificity for genomes having more than 50% GC (Schiex et al. 2003).

#### 11.5.4.4 Identification of Genes with *EasyGene*

In 2003, Larsen and Krogh developed gene-finder software based on hidden Markov model (HMM) that is estimated for a new prokaryotic genome. Automatically, a high quality training set of genes is extracted for genome and utilized in the estimation of the HMM. Then, the HMM scores putative genes and the statistical significance is calculated based on score and length of an ORF. The measure of statistical significance for one ORF is the expected value of ORFs in a megabase of random sequences at the identical significance level or better, where the random sequence contains the same statistics as the genome in the sense of third order Markov chain (Larsen and Krogh 2003). *EasyGene* provides comparable sensitivity to *GeneMarkS* and higher one than *Frame*. Although *EasyGene* and *Frame* are comparable in the respect of specificity, they have higher specificity than *GeneMarkS*. *GeneMarkS* has a log-odds score ability in the output to check the false high score for long ORFs which is caused due to rare occurrence of very long ORFs in random sequences, therefore genes of long sequence, for example 500 bp, have score below 0, then they are probably not real genes despite their length. This is an important discrimination as sometimes long non-coding ORFs occur in regions of repetitive DNA (Larsen and Krogh 2003). *EasyGene* is available at Central for Biological Sequence Analysis, Technical University of Denmark (DTU) website (<http://www.cbs.dtu.dk/services/EasyGene/>). To use this software, users are required to import single/several query sequences in FASTA format and customize their runs by deciding on model organism; R-value cutoff, indication of how likely it is to be just a non-coding ORF rather than a real gene; and suboptimal gene starts, which provides an alternative to default start codons.

#### 11.5.5 Microarray Analysis

Microarray analysis reveals which genes are expressed at a specific stage of the cell cycle, or particular external stimuli, and therefore, provides a global picture of gene expression for the genome. It can serve as a platform for the annotation of DNA sequences, the comparison of different genomes, and the observation of gene expression (Lee and Lee 2000). This type of information provides clues that will assist in the gene identification by determination of the related biological functions of genes and/or their contribution in biochemical pathways (Mount 2004). As the regulation of protein abundance in cells is done by regulation of mRNA, virtually all differences in cell state will be correlated to the alterations in the mRNA levels of many genes. Therefore, the only specific reagent required to calculate the abundance of mRNA for a given gene is a complementary DNA (cDNA) sequence (Schena et al. 1995), and

consequently, DNA microarray enables the exploration of thousands of genes simultaneously through hybridization of mRNA to a high-density array of immobilized probe sequences (Ball and Trevors 2002). A typical workflow for microarray analysis involves growing wild-type (wt) and mutant strains in defined conditions, the isolation of RNA, the isolation of mRNA, the synthesis of targets which is fluorescent (carbocyanine-labeled nucleotides Cy3-dCTP and Cy5-dCTP, red and green, respectively) or radioactive-labeled DNA derived from mRNA by RT-PCR, hybridization of targets to complementary probes of the array, scanning microarray, and analyzing intensified spots. Using this technique, the gene expression in microorganisms can be investigated under various growth conditions as well as environmental conditions (Ball and Trevors 2002). Additionally, genes involved in particular functions, for example, specific catabolic pathways, nitrogen fixation, antibiotic production, toxin production, or temperature resistance can be screened (Tanghe et al. 2000).

This approach has been successfully applied in global gene regulation in *Streptomyces griseus* by A-factor (2-isocapryloyl-3*R*-hydroxymethyl- $\gamma$ -butyrolactone), a bacterial hormone that triggers morphological differentiation and secondary metabolism. In this study, A-factor was added at specific concentration to mutant  $\Delta$ *afsA* at the middle of exponential growth phase, and then RNA samples were obtained from the cells grown followed by the addition of A-factor in various time fractions. The comparison of the transcriptomes with those obtained from cells grown in absence of A-factor evaluated the effects of A-factor on transcription of all protein-coding genes of *S. griseus*. Analysis of variance confirmed the different expression of 477 genes during the 12 h after the addition of A-factor (Hara et al. 2009). Additionally, in an older study, the effect of AdpA, a central transcriptional activator of secondary metabolism and morphogenesis in the A-factor regulatory cascade of the same genus has been revealed the direct or indirect activation of at least four of 34 gene cluster or genes of secondary metabolites production, including the streptomycin biosynthesis gene cluster (Ohnishi et al. 2008).

### 11.5.6 Functional Genomics

Genome sequences information have provided powerful tool for understanding cellular processes and analyzing bacterial metabolism. As genome information has increased, the studies have been concentrated mostly on comparative and functional genomics instead of structural genomics. Functional genomics studies the role and expression pattern of every gene in relation with other genes in the genome of an organism. DNA microarray technique attempts to examine numerous genes simultaneously using hybridization of mRNA and probes (Ball and Trevors 2002), and is the finding of genome transcriptional pattern and the determining of the differences in genetic profiles among different strains (Rick et al. 2001). The first step in the analysis of genes by microarray is primer designing for specific regions of genome. Generally, primers are designed for open reading frames (ORFs); however, ideal primers should contain both ORFs and the intergenic regions that include promoters and regulating elements (Lease and Belfort 2000). The computer programs such as PrimeArray or Primer 3 (<http://www-genome.wi.mit.edu/genome-software/other-primer3.html>) are commonly used for the primer design. Sometimes, primers

re-design and optimizations of reaction conditions are necessary to increase the yield of PCR amplification. In other way, the short oligonucleotides can be used instead of PCR products in DNA microarray. This oligonucleotide-based DNA microarray has advantages such as no need for amplification, fewer contaminations, less cross-hybridization, and high coverage of genome (Rick et al. 2001).

### 11.5.7 Comparative Genomics

The comparison of genes location, numbers and their roles as regulator or functional ones in a group of organisms refers to comparative genomics. Genomic information provides possibility to study and compare all proteins encoded by genomes of different strains with each other. XBASE (<http://www.xbase.bham.ac.uk>) is a bacterial genomes database with focus on comparative genomics. The system incorporates all bacterial full genome data from NCBI and WGS division of GenBank. The database of xBASE is updated every month after the new release of genome sequences in public databases. Currently the latest version is xBASE 2.0 (Chaudhuri et al. 2008). The Integrated Microbial Genomes (IMG) system provides comparative genome analysis, single cell genome analysis, and RNA sequence and biosynthetic cluster information. The analysis of public genome sequences (IMG/W: <http://www.img.jgi.doe.gov/w>), genome annotations (IMG/ER: <http://img.jgi.doe.gov/er>), and training in this area (IMG/EDU: <http://img.jgi.doe.gov/edu>) can be achieved by this genomic tool (Markowitz et al. 2014).

### 11.5.8 Genome Scanning in Actinobacteria

Genes requiring biosynthesis of secondary metabolites are generally clustered together in genome of bacteria (Martin and Liras 1989) which may be an advantage for the high-throughput genomics-guided approach in the identification of cryptic metabolic pathways (Zazopoulos et al. 2003). As an example, biosynthetic pathways of a variety of enediyne antitumor antibiotics-producing Actinobacteria have been uncovered by application of the genome analysis technique. Further, through comparative analysis, it was revealed that there is a conserved cassette including five genes that contains a novel family of polyketide synthase (PKS) and is involved in the synthesis of a highly reactive chromophore ring structure (Liu et al. 2002; Ahlert et al. 2002).

Short (700 bp) random genome sequence tags (GSTs) from a genomic DNA library of a bacterium are generated by a shotgun DNA sequencing approach. Sequence comparisons are used to identify GSTs of genes, involved in the secondary metabolite biosynthesis. Afterward, selected GSTs designed-screening probes are applied for the identification of cloned subgenomic fragments, such as bacterial artificial chromosomes (BACs) as well as cosmids, with the genes of interest and neighboring genes which together may represent a biosynthetic gene cluster. In the regard of the identification of gene clusters involved in natural product biosynthesis, genome analysis provides an efficient tool since it provides reasonable assurance of full genome representation by the analysis of a relatively small number of GSTs (Zazopoulos et al. 2003). A typical gene cluster involves in the formation of natural



product ranges in size from 20 to 200 kbs (Beyer et al. 1996; Schwecke et al. 1995), therefore it is expected that by analyzing every 1000 GSTs, any given gene cluster will be represented 2 to more than 20 times.

High-molecular-weight genomic DNA obtained from *Actinobacteria* were employed for generation of a small insert genomic sampling library (GSL) as well as a large-insert cluster identification library (CIL). GSL is generated by the sonication of DNA followed by agarose gel electrophoresis-prepared fragments of 1.5–3.0 kbp and cloning them into plasmid vectors. Even though, CIL is generated by partial digestion restriction endonuclease *Sau3A1*-aided fragmentation of genomic DNA to a size range of 30–50 kbs followed by cloning into cosmid vectors. Each GSL is represented to one thousand gene sequence tags (GSTs) (average read length, 700 bp), is translated into amino acid sequence, and will be compared within databases such as DECIPHER, Ecopia Bioscience Inc., Montreal, Canada; <http://www.ecopiabio.com>, and gene sequence likely to be involved in biosynthesis of natural products can be identified by applying the basic local alignment search tool protein database (BLASTP) software (<http://www.ncbi.nlm.nih.gov/>). An important parameter is the size and breadth of the database compared with, as the efficiency of the genome scanning approach depends on the discrimination power of primary and secondary metabolism genes from each other. Therefore, the probability of the identification of a particular gene cluster by the analysis of a given GSTs number will increase. For the isolation and the identification of enediyne biosynthesis genes from various enediyne-producing actinobacterial strains, a significant antitumor antibiotics (Doyle and Borders 1995) above approach was adopted. The presence of the conserved enediyne warhead cassette genes and other frequently found genes in biosynthetic loci encoding other classes of secondary metabolites were used in the identification of enediyne biosynthetic loci (Zazopoulos et al. 2003).

### 11.5.9 Molecular Cloning

Molecular cloning is a technique in the field of molecular biology, concerning the identification of molecular mechanisms and structures that are responsible for cell growth and development, differentiation, division, and metabolism as well as understanding of the function, structure, and regulation of genes and their products. More importantly, manipulation of molecules are key points of such processes and the observation of the changes in cells which can be implemented by molecular cloning (Davis 2012). In the regard of secondary metabolite production, *in vitro* interspecific recombination method of molecular cloning finds application to bioactive compound-producing bacteria and leads to enhanced metabolic production. However, to fulfill such approaches, genes responsible for biocompound synthesis must be isolated, analyzed, and even modified (Malpartida and Hopwood 1984). Example of this perspective is the recruitment of molecular cloning technique for isolation of complete genetic information necessary for the formation of actinorhodin, an aromatic polyketide pigment which belonged to isochromanonequinones class of antibiotic from *Streptomyces coelicolor* DNA. In this experiment, pIJ922 (25 kb) which developed from a 31-kb sex factor of *Streptomyces coelicolor*, known as the plasmid SCP\*, and has single site for restriction enzymes was used as cloning vector. The

cloned DNA was prepared by first purification of pIJ922 DNA using CsCl-ethidium bromide density gradient centrifugation, alkaline lysis, and digestion with *Bam*HI. Then the product was subjected to phenol extraction and linearized plasmid was mixed with chromosomal DNA from *act*<sup>+</sup> *S. coelicolor* strain which sized in the range of 15–30 kb (sucrose density gradient) by partial digestion with *Mbo*I. After ligation, cloned DNA was used to transform a mutant of *act* class V that was deficient in a late step of the biosynthesis of actinorhodin. Recombinants were identified by the generation of blue color on R2YE medium plates. Finally, a continuous segment of DNA was isolated and proved to be responsible for actinorhodin synthesis by complement activity of its production when cloned into actinorhodin non-producing *S. coelicolor*. Additionally, its introduction into *Streptomyces parvulus* also resulted in the antibiotic production (Malpartida and Hopwood 1984).

Another prominent impetus for the deduction of secondary metabolic biosynthesis pathways is the provision of a scaffold for developing a deep understanding of the mechanisms governing selectivity in key secondary metabolic biosynthetic enzymes that in turn suggests several strategies for engineering the production of novel secondary metabolites with enhanced or modified activities. For example, prodiginines, which belong to red-pigmented oligopyrrole antibiotics family, rendered medicinal potential as immunosuppressants and antitumor agents that are synthesized by several Actinobacteria. However, their toxicity has inhibited prodiginines application for medicine (Cerdeño et al. 2001). In 2001, sequence comparison was used to assign functions to the most of the genes in the previously sequenced undecylprodiginine and butyl-*meta*-cycloheptylprodiginine, several of which encode homologues of enzymes participated in fatty acid, non-ribosomal peptide, and polyketide biosynthesis. Consequently, a complete biosynthesis pathway for these compounds in *Streptomyces coelicolor* has been provided, and function of some genes in the cluster has been identified by gene knock-out experiments. Roles of five out of 23 genes could not be deduced because of their low similarity to genes of known function in the database. To conduct the study, *Escherichia coli* DH5 $\alpha$  and *Streptomyces coelicolor* strains M511 and M521 were used as the cloning hosts for the construction of plasmids and *red* gene deletion mutants, respectively. *E. coli* ET12567 was applied as the host for conjugational transfer of plasmids to *Streptomyces coelicolor*. pIJ4126, pIJ4136, pIJ4148, and pIJ6013 were used as cloning vector which contained portions of the *red* cluster. However, subcloning in *E. coli* was performed using pHJ2925 and pBLUESCRIPT SK+ vectors. Finally, gene deletions in *Streptomyces coelicolor* was fulfilled by vectors pKC1132 and pSET151 that were capable of conjugal transfer from *E. coli* to *Streptomyces* spp. (Cerdeño et al. 2001).

---

## 11.6 Metabolite Analysis

### 11.6.1 Applications and Significances of Dereplication

Actinobacteria provide numerous secondary metabolic products that can be exploited as bioresource materials aimed at the discovery of new medicines. However, the achievement of these exploitations is strongly under influence of the efficacy of performance of compound screening programs, which itself is depended on the availability of equipment,

labor and time investments necessary for the isolation and the structural elucidation of new metabolites with biological properties. Despite great improvements in analytical methods for the exploration of new natural compounds, the frequent isolation of known compounds after heavy investments of money and time resulted in slowed down or termination of natural product research activities by many pharmaceutical companies. However, the need for novel chemical structures from naturally occurred compounds is demanded by drug discovery industry. Therefore, a solution for considerable reduction in the expense, effort and timeline for chemical profiling of natural products is dereplication procedure, which is a term coined by Beutler et al. (1990) and can be defined as a process of quickly identifying known chemotypes (Beutler et al. 1990). Since structurally related or identical molecules share identical physical characteristics including chromatographic retention times, mass spectrometry (MS), ultraviolet (UV)-vis profiles, and nuclear magnetic resonance (NMR) chemical shifts, or biological properties; dereplication technique, to some extent, elucidates crude extracts to differentiate already identified natural products from novel compounds that are of interest (Yang et al. 2013).

### 11.6.2 Dereplication System and Hyphenation Possibilities

Dereplication requires reliable, rapid, robust, and sensitive analytical techniques to achieve an efficient identification of known secondary metabolites. Remarkable developments in separation science, high-throughput analytical and spectroscopic techniques provided various possible approaches with different advantages in sensitivity, resolution, or scale (mg vs  $\mu\text{g}$ ) for dereplication process. Some of these methods have been reviewed here.

High performance liquid chromatography (HPLC) is the most demanded technique to separate natural compounds due to its robustness, simplicity, and applicability to diverse compounds even with sophisticated chemical skeleton. Among other common chromatographic dereplication methods are ultra-high pressure liquid chromatography (UHPLC), with greater sensitivity, resolution, and reproducibility than the conventional HPLC and both techniques commonly referred to as liquid chromatography (LC); Thin layer chromatography (TLC or HPTLC), frequently used for the rapid identification of known compounds following pre-fractionation of a crude extract, or for the preliminary analysis of natural extracts; TLC-based bioautographic methods, allowing rapid localization of biologically potent compounds directly on TLC plates and gas chromatography (GC), used for dereplication of small volatile molecules, as well as flavor and aroma constituents (Hubert et al. 2015). However, two latter tools are not applicable for dereplication of a number of natural compounds.

Ultraviolet (UV) or photodiode array (DAD) detectors coupled with LC provide limited structural information recovered from peak retention times or UV spectral fingerprints and require standard molecules as reference for both identification and quantification purposes (Wolfender 2009). In contrast, MS and NMR are powerful instruments that provide knowledge about the structural diversity of the natural products (Hubert et al. 2015). The former is sensitive, rapid, accurate and high-throughput detection technique which characterizes trace-level natural products on the basis of exact mass, elemental composition, adducts, and fragmentation patterns. Therefore, equipping LC with high-resolution mass spectrometers including Fourier Transform (FT),

Time-of-Flight (TOF), or Orbitrap devices currently regarded as the most powerful screening tool for on-line identification of compounds in natural resources (Hubert et al. 2015). In addition, gas chromatography (GC)/MS is more suitable coupling for dereplication of hydrophobic or volatile small molecules such as fatty acids (Stavri et al. 2004) or aroma and flavor components (Molyneux and Schieberle 2007). Variability in raw datasets obtained from one mass analyzer to another, diversity in ionization processes as well as matrix effects on ionization suppression or enhancement, and different interpretation of MS data are amongst the major difficulty in application of MS for dereplication process (Hubert et al. 2015). The last problem can be partially solved with the implementation of computer for analysis of mass spectral data. Processing software for LC-MS, which facilitates peak recognition, ion extraction, organization and classification of data, includes MassHunter for Agilent, Bruker Data Analysis and Bruker Profile Analysis for Bruker, MarkerLynx™ for Waters or publicly accessible software such as MZmine, XCMS, and MET-IDEA, and are able to manage data from various instruments. Additionally, among computer tools assisting metabolite identification are ISIS, which is based on the prediction of fragmentation patterns by spectral comparisons; MetFusion, which utilizes substructures to determine spectral and chemical similarities; FT-BLAST, which is based on differentiation using a fragmentation tree database; and FingerID, which compares molecular structures after prediction of structural features (Hufsky et al. 2014). Another emerging technology in the field of natural products dereplication is LC/NMR, which allows direct comparison of metabolite profiles in small-scale extracts by  $^1\text{H}$  NMR. In the case of LC/SPE/NMR, natural extracts are separated by liquid chromatography, then analyte peak is trapped on solid phase extraction cartridges and concentrated, which also allows 2D NMR in the last step. These strategies greatly minimize re-isolation of already known products (Hubert et al. 2015).

NMR is by far the most potent method to unambiguously elucidate sophisticated structures of small compounds. High field magnets, capillary and cryogenic probes in addition to more sophisticated transforming software, for example, NMRbot Python scripts have improved the sensitivity of NMR to that of MS-based analytical methods (Clos II et al. 2013). However, solvent and pH introduce considerable chemical shift variations across samples, which are significant disadvantages of NMR-based dereplication methods. Additionally, the limited spectral dispersion as well as the complexity of signal patterns, especially in  $^1\text{H}$  NMR spectra, are challenging when crude natural products are investigated (Pauli et al. 2014). Today, acquisition of  $^{13}\text{C}$  spectra of natural metabolite mixtures with acceptable resolution and sensitivity, and in an appropriate timeline has been emerging due to the technical improvements in NMR spectrometers as well as its methodologies, for example, dynamic nuclear polarization (Hubert et al. 2015). To simplify interpretation of NMR spectra of natural crudes, diffusion ordered spectroscopy (DOSY) or total correlation spectroscopy (TOCSY) can be used.

### 11.6.3 Dereplication Workflows of Natural Products

Based on the workflow, dereplication can be categorized into five distinct groups. In the first category, annotated as DEREPI, chemical profile of a single natural resource is elucidated, and the spectroscopic data obtained is directly compared to natural metabolites of databases. In the context of this group, one crude natural sample is fractionated

to simplify the mixtures, which are then subjected to untargeted analysis by dereplication methods such as LC-DAD, LC-MS, NMR, LC-NMR followed by database search. This approach, which has been implemented as a strategy for dereplication of natural product by up to 16% of the total published works mentioning the term “dereplication” during a 24 years from 1990 to 2014, results in quick identification of the major known compounds present in an extract (Hubert et al. 2015). On the other hand, in the second group, known as DERE2, bioactivity-guided fractionation procedures are coupled with dereplication technique. The former procedures screen compounds with a predefined biological activity from those of inactive metabolites (Agarwal et al. 2014), whereas the latter technique minimizes the frequent issue of re-identification of known compounds. Almost 17% of the total examined articles, in a 24-year duration, have recruited DERE2 workflow, which is the same as DERE1 steps, except that in DERE2 either biological tests are conducted on all fractions obtained after fractionation and then only active fractions are analyzed, which results in the identification of known and active compounds; or all fractions are first analyzed and then biological tests are only conducted on fractions of unknown composition, which results in targeting new structures (Hubert et al. 2015). Interestingly, the main characteristic of the DERE3 is the ability to directly elucidate molecular structures within crude extracts of bacteria without any fractionation step. This dereplication approach leads to high-throughput chemical profiling of natural extract collections after direct and untargeted analysis of collected crude natural extract to obtain statistics pattern recognition, which in turn is checked with metabolite databases (Hubert et al. 2015). The described procedure has been applied in same number of article as DERE1 procedure. The fourth group, called “DEREP4,” is based on targeted chemical profiling, in which a predefined number of products or a specific chemical class of molecules is studied and the molecular structures are elucidated. This method is described in up to 18% of the total articles on dereplication in the same duration. The workflow consists of either fractionation of natural extract/s to simplify mixtures and then subjected to targeted analysis or direct exposure of the extracts to targeted analysis, which is done mostly by LC/MS in both approaches. Subsequently, information is compared with natural product databases. The main objective of DERE4-based studies is either to discover potentially toxic or undesired natural molecules of crude extracts or, in contrast, to explore a particular group of compounds displaying a particular biological activity (Hubert et al. 2015). Finally, dereplication methods in fifth group (DEREP5), covering almost 23% of the total surveyed articles in the period of consideration, are mainly based on phenotypic characteristics or genetic diversities to differentiate bacterial isolates at the level of species, hence adopting genetics and metabolic engineering as an integral part of dereplication strategies. Therefore, by applying metagenomic approaches, access to numerous gene sequences in microorganisms is provided (Hubert et al. 2015). A typical workflow of these approaches includes taxonomic dereplication of microbial strains by 16S rDNA gene sequencing or PCR-fingerprinting of large collections of isolates. Thereafter, phylogenetic similarities are correlated and discriminated strains are identified by clustering analysis known as taxonomic dereplication. Once taxonomical identification is achieved, promising ones will be determined through comparing information with a microbial strain database. Sensitive analytical instruments will be recruited for future investigations of metabolite profiles to discover potentially new bioactive metabolites and collection of above described processes can lead to the discovery of untapped bioactive molecules (Hubert et al. 2015).

## 11.6.4 Natural Product Databases

Availability and quality of natural metabolites libraries have a pivotal role in the achievement of accurate dereplication of known compounds. Some comprehensive dereplication databases will be discussed below.

### 11.6.4.1 The Dictionary of Natural Products (DNP)

The compilation of DNP is undertaken at Chapman & Hall with information on over 270,000 natural compounds. A characteristic feature of the software is the organization of closely related products; for example, where one compound is a glycoside or simple ester of another, information can be found into the same entry to simplify and display the underlying structural and biosynthetic relatedness of the molecules. Structure illustrations are drawn and numbered according to stereochemical and biogenetic relationship. Additionally, indexing of every natural product is done by structural/biogenetic type under one of approximately 1000 headings, providing the rapid location of all molecules in the category, even if they have undergone biogenetic modification and share different skeleton. This software is commercial and available at <http://www.chemnetbase.com>.

### 11.6.4.2 AntiBase

*AntiBase* is a commercial natural compound identifier and has provided 42,950 natural compound entries in its 2014 edition. Data from primary and secondary literature are obtained and carefully validated. A wide range of data including descriptive, physico-chemical, spectroscopic, and biological data in addition to information on origin and isolation, and a literature survey has been provided by *AntiBase*. Additionally, it can uniquely provide a prediction of  $^{13}\text{C}$ -NMR spectra for those molecules which lack measured spectra using the Wiley's proprietary NMR spectrum prediction algorithm. This software is available at Wiley website (<http://eu.wiley.com/WileyCDA/WileyTitle/productCd-3527338411.html>).

### 11.6.4.3 MarinLit

In 1970s, John Blunt and Murray Munro established *MarinLit* at the University of Canterbury, New Zealand. It is primarily adopted for the dereplication of marine natural products. It covers marine natural compounds in journal articles such as new and revised compounds, synthesis, ecology, and biological activities. Included with the software are the possibility to search on substructures, NMR structural features, calculated  $^{13}\text{C}$  and  $^1\text{H}$  NMR shift data, exact masses, chemical formula, UV  $\lambda_{\text{max}}$ , and  $\log \epsilon$  and their combination thereof. *MarinLit* is a commercial software and cited in 29,449 articles at the present time. It is available at Royal Society of Chemistry website (<http://pubs.rsc.org/marinlit/>).

## 11.6.5 Some Strategies for Dereplication

There are many different strategies for dereplication of naturally synthesized secondary metabolites based on the group of interest compounds and available instruments. Some of the important approaches have been outlined in this section.

### 11.6.5.1 Molecular Networking

A molecular network is a visual representation of the chemical similarity or the molecular relatedness of any provided set of compounds. In mass spectrometry-based molecular networking, structurally identical molecules which share similar MS/MS fragmentation patterns are recognized. This technique is implemented within three fundamental steps including the collection of MS/MS spectra, the generation of a molecular network using “cosine scores” to measure relatedness in MS/MS spectra and the visualization of correlations of large data sets using tools such as Cytoscape, and analyzing molecular network (Yang et al. 2013). The implementation of these steps results in the organization of natural products based on their similarities in MS/MS fragmentation patterns into molecular families, which makes them clustering together within a network (Nguyen et al. 2013). The developed network can be used for the simultaneous visual exploration of similar molecules, analogues, or compound families, in single or multiple data sets and establishes an extensive variety of biological resources (Nguyen et al. 2013).

### 11.6.5.2 HPLC Bioactivity Profiling Technique in Conjunction with Capillary Probe NMR

In this method, the dereplication process for bioactive extracts are initiated by subjecting crude extract to reversed-phase HPLC purification and fractionated in a microtiter plate (with constant maintenance of all HPLC parameters over years for reliable comparisons of data obtained). Various UV spectra and retention times are recorded for all present bioactive peaks and compared with an in-house library of known bacterial compounds. If no match could be found with the in-house UV library, then spectra of bioactive compounds in microtiter plate are obtained by capillary NMR probe (CapNMR). Subsequently, these spectra are examined for characteristic features that are compared with the *AntiMarin* (Blunt et al. 2006) database, a merged data from *MarinLit* and *AntiBase* software with almost 47,000 unique compounds, for dereplication purposes (see above). In addition, MS data can be incorporated to tighten the search within the databases. The described method requires microgram quantities of extract and uses the discriminating power of  $^1\text{H}$  NMR spectroscopy as a definitive dereplication tool (Lang et al. 2008).

### 11.6.5.3 Combination of Mass Spectrometric Metabolic Profiling and Genomic Analysis/Metabolomic Tools

The comprehensive analysis of small molecules with a molecular weight of less than 1000 D in a biological system under provided conditions is defined as metabolomics (Fiehn 2001). At biochemical level, these small molecules, metabolomes, are closely related to the phenotypes. Therefore they provide insight into the biological function (Van Der Werf et al. 2005).

An innovative method was developed for the discovery of novel natural compounds by taking advantages of mass spectrometric metabolic profiling and genomic analysis in 2015 (Kleigrewe et al. 2015). In this approach, the desired bacteria are subjected to genome sequencing and analysis to obtain their recognizable biosynthetic pathways, and this data are compared with their respective detected metabolomes using MS profiling. Thereafter, compounds are identified by MS-based molecular networking, and subsequently, are isolated and subjected to structure elucidation (Kleigrewe et al. 2015). The total number of compounds as well as compound classes present in a crude

natural product extract can be inferred by the mass spectrometric based metabolomics technique. Moreover, it is possible to develop tentative structural data on novel compounds by a technique which combines high-resolution mass spectrometry (HRMS) with the molecular ion isotopic pattern, and with MS<sup>2</sup>-based fragmentation analyses. Consequently, the combination of genomics and metabolomics provides the possibility of correlating the particular compounds to their respective gene clusters or vice versa (Medema et al. 2014; Kersten et al. 2011). Another approach of metabolomics-based dereplication for discovery of secondary metabolic products involves high-throughput selection of unique strains by the examination of their chemical profiles compared with the total available bacterial pattern through liquid chromatography-high resolution mass spectrometry (LC-HRSM) as well as NMR spectroscopy. The mass spectrometric data are compared with *AntiMarin* database, and subsequently, bacterial strains are differentiated with multivariate analysis by principal component analysis (PCA), in which similar metabolites-producing bacteria are grouped together, whereas those species producing distinct secondary metabolomes are observed as outliers. Additionally, NMR <sup>1</sup>H and correlation spectroscopy (COSY) can be applied to provide a chemical fingerprint of each bacterial strain and confirm the existence of functional groups. In the last step, combination of the results with taxonomic identification and bioassay screening information is performed, which helps to distinguish the potent strain for further metabolites isolation and purification work (Macintyre et al. 2014).

#### Some dereplication approaches using various workflows (newest to oldest)

Some examples of articles used dereplication categories 1 and 4 as an approach			
Chemical classes and natural sources discovered	Analytical method	Dereplication category	References
Four macrotetrolides homologous to nonactin and three related linear dimers from <i>Streptomyces</i> sp.	MS, LC/MS <sup>2</sup>	DEREP1	Crevelin et al. (2014)
Ten known compounds, including angucycline, diketopiperazine and b-carboline and three novel derivatives produced in the culture medium of <i>Actinokineospora</i> sp. EG49 grown in co-culture with <i>Nocardiopsis</i> sp.	NMR	DEREP1	Dashti et al. (2014)
Pyrrolamide compounds including congocidine and distamycin in fermentation culture of <i>Streptomyces netropsis</i>	Genome scanning and precursor ion scan MS	DEPREP4	Hao et al. (2014)
Hydroxylated fatty acids, antimycin compounds and three butenolides from a sponge-derived <i>Streptomyces</i> sp. with antibacterial and antifungal activities	LC/MS	DEREP1	Viegelmann et al. (2014)
Two known naphthocoumarins and one new naphthocoumarin from <i>Streptomyces sporoverrucosus</i>	HPLC–PDA/LC–MS combined to DNP, 2D NMR	DEREP1	Jain et al. (2013)



## Some examples of articles used dereplication categories 1 and 4 as an approach

Chemical classes and natural sources discovered	Analytical method	Dereplication category	References
Quantification of structurally diverse standard natural products	ELSD	DEREP1	Hou et al. (2012)
719 microbial natural product and mycotoxin standards	LC/DAD/ TOF-MS, MS/ MS under different ion-source settings	DEREP1	Nielsen et al. (2011)
Linear polyketides and tubercidin from <i>Actinopolyspora erythraea</i>	ID and 2D NMR	DEREP1	Zhao et al. (2011)
Streptothricin-like compounds in the fermentation broth of <i>Streptomyces qinlingensis</i>	Ion-pair LC/ ESI-MS	DEPREP4	Ji et al. (2008)
Two known antibiotics teicoplanin and phenelfamycin in several microbial crude extracts	LC/UV/ESI-MS/ MALDI-MS	DEPREP4	Ackermann et al. (1996)
Elaiophylin and geldanamycin in a range of microbial broths	CPC/DAD, LC-MS	DEPREP4	Alvi et al. (1995)

## Some examples of articles used dereplication categories 2, 3 and 5 as an approach

Strategy	Goal	Dereplication category	References
PCR analysis of 100 strains randomly selected from an actinomycete collection to evaluate their ability to biosynthesize aromatic polyketides, reduced polyketides, nonribosomal peptides, and diterpenoids	Extract prioritization by biosynthetic potential survey	DEREP5	Xie et al. (2014)
Investigation of <i>Streptomyces lavendulae</i> phenotypic cluster for production of lipstatin-like lipase inhibitors using a taxonomy-based dereplication with a public collections of strains and in vitro assays	Identification of potentially novel and useful industrial <i>Streptomyces</i> strains	DEREP5	Sladič et al. (2014)
Metabolomic analysis of antitrypanosomally active sponge-associated <i>Actinokineospora</i> sp. obtained in four fermentation conditions using HR-FT-MS and NMR combined to PCA, HCA and OPLS-DA	Identification of the best culture one strain-many-compounds conditions	DEPREP3	Abdelmohsen et al. (2014)
Metabolomic analysis of <i>Streptomyces</i> isolated from geographically varied environments using LC/MS combined to bucketing and presence-absence standardization strategy, PCA and HCA	Discrimination of microbial strains and identification of novel compounds	DEPREP3	Forner et al. (2013)

Some examples of articles used dereplication categories 2, 3 and 5 as an approach

Strategy	Goal	Dereplication category	References
Characterization of the pigment profiles of 400 bacterial isolates using MALDI-TOF-MS dendrograms	Taxa discrimination and identification of novel carotenoids with UVA-Blue light absorbing properties	DEPREP3	Stafsnes et al. (2013)
Cytotoxicity-guided identification of one unknown and one known compounds from Marine-derived <i>Streptomyces</i> sp. compounds	Microprobe NMR, ESIMS	DEREP2	Mahyudin et al. (2012)
Metabolomic analysis of marine-derived bacterial natural products using LC/MS with PCA	Strain prioritization in a drug discovery program	DEPREP3	Hou et al. (2012)
High-throughput LC/MS analysis of 16,025 microbial extracts, binning by nominal mass and retention time, data visualization by scattered plots and elimination of the ubiquitous peaks to focus on unique compounds	Investigation of extract chemical diversity	DEPREP3	Ito et al. (2011)
Metabolomic analysis of crude extracts obtained from actinomycetes in different cultivation medium by direct infusion MS and LC/MS	Identification of novel microbial metabolites	DEPREP3	Crevelin et al. (2010)
Explorative solid-phase extraction and ion-exchange chromatography for the chemical profiling of microbial extracts	Extract prioritization, mapping of biological activities	DEPREP3	Månsson et al. (2010)
Chemical screening of thirteen antibiotics and four cultivation broths by LC/DAD and fingerprint analysis based on polarity, UV spectra and acid-base properties	Identification of novel potent antibiotics among microbial metabolites	DEPREP3	Kameník et al. (2010)
Evaluation of the antimicrobial activity and subgrouping of 217 streptomycetes isolates from the water surface microlayer in Norway by phylogenetic analysis and 16S rDNAs sequencing. Seven isolates with identical 16S rDNA sequences were further studied for the presence of PKS type I genes	Investigation of Actinomycetes from the water surface microlayer as a source of new antimicrobial agents	DEREP5	Hakvåg et al. (2008)

Some examples of articles used dereplication categories 2, 3 and 5 as an approach

Strategy	Goal	Dereplication category	References
Chemical profiling of fungal or bacterial extracts using an HPLC bioactivity profiling/microtiter plate technique in conjunction with capillary probe NMR instrumentation and databases	Demonstration of the discriminating power of H-1 NMR as a dereplication tool	DEPREP3	Lang et al. (2008)
Identification of 26 closely related <i>Streptomyces</i> soil isolates using rDNA sequencing, MIDI fatty acid analysis, and LC-MS profiling of fermentation extract	Discrimination between morphologically similar strains	DEREP5	Ritacco et al. (2003)
Investigation of unusual strains of actinomycetes and filamentous fungi by reconstruction of gene clusters from small segment of cloned DNA and preparation of large-insert libraries	Detection of uncommon genera of soil microbes	DEREP5	Donadio et al. (2002)

**Some examples of different types of DNA microarrays for microbial systems (Rick et al. 2001)**

DNA	Surface or matrix	Reference
10–400-bp fragments	Microelectronics	Nanogen ( <a href="http://www.nanogen.com">http://www.nanogen.com</a> )
PCR products	Membrane	SigmaGenosys ( <a href="http://www.genosys.com">http://www.genosys.com</a> )
Oligonucleotides	Polacrylamide	Proudnikov et al. (1998)
Glass	Long oligonucleotides	Operon ( <a href="http://www.operon.com">http://www.operon.com</a> )
	Short oligonucleotides	Affymetrix ( <a href="http://www.affymetrix.com">http://www.affymetrix.com</a> )
	PCR products	DeRisi Eurogentec ( <a href="http://www.eurogentec.com">http://www.eurogentec.com</a> )

#### 11.6.5.4 Genomics-Guided Natural Products Discovery

There is significantly larger number of biosynthetic genes in Actinobacteria than metabolites actually isolated following their laboratory cultivations mainly due to totally dormant genes, partial activation of biosynthetic pathways under the growth conditions, or bioassay-guided isolation of specific compounds. Therefore, genomics-guided natural products discovery is considered fruitful by high-throughput scanning of secondary metabolite gene clusters (Farnet and Zazopoulos 2005; Singh and Pelaez 2008). The obtained data are then compared with a growing library of genes from various microorganisms which encode numerous known natural metabolites with maximal chemical diversity. This allows successful discovery of a number of gene clusters predicting a chemically diverse new structures (Singh and Pelaez 2008). Subsequently, these predicted novel structures can be produced by growing the strain under appropriate conditions, especially applying high-throughput cultivation methods, as well as their detection from fermentation media

by suitable analytical methods for these new predicted molecules (Singh and Pelaez 2008). A profound improvement of this method was performed by cultivation in 96-well plates with potential for automation, providing opportunities for the conduction of effective fermentations in multiple conditions, resulting in a decrease of scale as well as cost (Singh and Pelaez 2008). The mentioned improvement can vigorously increase the possibility for the exploration of the metabolic potential of Actinobacteria by biosynthetic genes activations as a result of modifications in growth conditions (Singh and Pelaez 2008).

#### 11.6.5.5 Mining Bacterial Genomes for New Biosynthetic Pathways

Employment of various techniques with the power of mining bacterial genomes can effectively lead to simplified discovery of new natural product as well as biosynthetic pathways. Some examples of these techniques in identification of the metabolic products of cryptic gene clusters will be discussed here.

Generally, the number of modules in the assembly line correlates perfectly with the number of metabolic building blocks, which have been incorporated into final product (Haynes and Challis 2007). The existence or extinct of domains with tailoring activities in individual modules usually allows prediction of the procedure in which an initially labeled metabolic building block is modified during the process of its incorporation into the natural metabolite (Fischbach and Walsh 2006; Challis 2008). Understanding of cryptic biosynthetic assembly lines can generally be obtained by employing bioinformatics analyses, which consequently leads to the prediction of significant physico-chemical properties of a metabolite of a cryptic biosynthetic system. Subsequently, these physico-chemical properties predicted are used to tighten the search of fermentation broths for products of cryptic pathways, and therefore to target only natural products of chemically interest (Challis 2008).

Genome-isotopic approach and *in vitro* reconstitution applied for the identification of cryptic biosynthetic systems, where substrates of enzymes in the pathways are predicted. One approach uses stable isotope-labeled putative precursors of the metabolic product to feed the bacterium having cryptic biosynthetic gene cluster. Then, 2D NMR experiments are applied to screen crude extracts obtained from the fermentation broth for the identification of labeled precursors-containing metabolites. The purification of these metabolites can be facilitated by using NMR-guided fractionation (Gross et al. 2007). On the other hand, the second approach employs the recombinant production of a biosynthetic enzyme in pure form, followed by its incubation with the predicted substrates of that enzyme. Then, structures of the product are determined (Challis 2008). When substrate specificity cannot be confidently predicted by bioinformatics analysis, both the directed approaches discussed previously, i.e. genome-isotopic and *in vitro* reconstitution methods are useless in the exploration of the metabolic products of cryptic biosynthetic pathways. In this case, more generic approaches, such as heterologous gene expression/comparative metabolic profiling and gene knockout/comparative metabolic profiling, are employed for the identification of metabolites of cryptic biosynthetic gene clusters (Corre and Challis 2007). In the former technique, inactivation of a gene within the cryptic biosynthetic gene cluster assumed to be crucial for metabolite biosynthesis is performed, then metabolite produced by wild-type organism is compared with

that of mutant by appropriate analytical methods, for example, LC-MS. Consequently, those metabolites that are present only in wild-type bacteria are possible products of the cryptic gene cluster, which are isolated and structurally characterized (Challis 2008). On the other side, the latter technique involves cloning of the whole biosynthetic gene cluster, commonly in a single cosmid or bacterial artificial chromosome (BAC) vector, and expressing in a heterologous host. The metabolites profile of extracts of the heterologous host lacking and containing the cloned cryptic biosynthetic gene cluster is compared by appropriate analytical techniques such as LC-MS. Those compounds that are only produced by the cloned host are possible metabolites of the cryptic biosynthetic pathway, which are purified and structurally elucidated as in the former approach (Challis 2008). The significant issue encountered in the heterologous expression/comparative metabolic profiling technique is the large size (40 kb) of natural product biosynthetic gene clusters which makes the clone of the entire cluster in a single vector very challenging. One solution is the application of multiple, mutually compatible expression vectors clone, although it has yet to be investigated (Challis 2006).

A common drawback of above techniques is inexpression of the cryptic biosynthetic gene cluster in heterologous host or wild-type organism. Although in vitro reconstitution method does not have the mentioned problem by deleting the biosynthetic genes from their regulatory context, it involves separate overexpression of each gene and purification of their synthesized metabolites which is laborious (Challis 2006). Therefore, cryptic or orphan biosynthetic gene clusters having potential to direct the synthesis of sophisticated novel natural metabolic compounds can be detected in genome sequences.

---

## References

- Abdelmohsen UR, Cheng C, Viegelmann C, Zhang T, Grkovic T, Ahmed S, Quinn RJ, Hentschel U, Edrada-Ebel R (2014) Dereplication strategies for targeted isolation of new antitrypanosomal actinosporins A and B from a marine sponge associated-*Actinokineospora* sp. EG49. *Mar Drugs* 12(3):1220–1244
- Ackermann BL, Regg BT, Colombo L, Stella S, Coutant JE (1996) Rapid analysis of antibiotic-containing mixtures from fermentation broths by using liquid chromatography-electrospray ionization-mass spectrometry and matrix-assisted laser desorption ionization-time-of-flight-mass spectrometry. *J Am Soc Mass Spectrom* 7(12):1227–1237
- Agarwal A, D'Souza P, Johnson TS, Dethe SM, Chandrasekaran C (2014) Use of in vitro bioassays for assessing botanicals. *Curr Opin Biotechnol* 25:39–44
- Ahlert J, Shepard E, Lomovskaya N, Zazopoulos E, Staffa A, Bachmann BO, Huang K, Fonstein L, Czisny A, Whitwam RE (2002) The calicheamicin gene cluster and its iterative type I enediyne PKS. *Science* 297(5584):1173–1176
- Alvi K, Peterson J, Hofmann B (1995) Rapid identification of elaiophyllin and geldanamycin in *Streptomyces* fermentation broths using CPC coupled with a photodiode array detector and LC-MS methodologies. *J Ind Microbiol* 15(2):80–84
- Altschul SF, Gish W, Miller W, Myers EW, Lipman DJ (1990) Basic local alignment search tool. *J Mol Biol* 215(3):403–410
- Baldacci E, Spalla C, Grein A (1954) The classification of the Actinomycetes species (*Streptomyces*). *Arch Microbiol* 20:347–357
- Baldacci E, Farina G, Locci R (1966) Emendation of the genus *Streptovercillium* Baldacci (1958) and revision of some species. *G Microbiol* 14:153–171

- Ball KD, Trevors J (2002) Bacterial genomics: the use of DNA microarrays and bacterial artificial chromosomes. *J Microbiol Methods* 49(3):275–284
- Benedict RG, Pridham TG, Lindenfelser LA, Hall HH, Jackson RW (1955) Further studies in the evaluation of carbohydrate utilization tests as aids in the differentiation of species of *Streptomyces*. *Appl Microbiol* 3:1–6
- Besemer J, Borodovsky M (1999) Heuristic approach to deriving models for gene finding. *Nucleic Acids Res* 27(19):3911–3920
- Besemer J, Lomsadze A, Borodovsky M (2001) GeneMarkS: a self-training method for prediction of gene starts in microbial genomes. Implications for finding sequence motifs in regulatory regions. *Nucleic Acids Res* 29(12):2607–2618
- Beutler JA, Alvarado AB, Schaufelberger DE, Andrews P, McCloud TG (1990) Dereplication of phorbol bioactives: Lyngbya Majuscula and Croton Cuneatus. *J Nat Prod* 53(4):867–874
- Beyer S, Distler J, Piepersberg W (1996) Thestr gene cluster for the biosynthesis of 5'-hydroxystreptomycin in *Streptomyces glaucescens* GLA. 0 (ETH 22794): new operons and evidence for pathway-specific regulation by StrR. *Mol Gen Genet* 250(6):775–784
- Bland CE, Couch JN (1981) The family Actinoplanaceae. In: Starr MP, Stolp H, Trüper HG, Balons A, Schlegel HG (eds) *The Prokaryotes – a handbook on habitats, isolation and identification of bacteria*. Springer Verlag, Berlin, pp 2004–2010
- Blinov NO, Khokhlov AS (1970) Pigments and taxonomy of actinomycetales. In: Prauser H (ed) *The Actinomycetales*, Jena Int. Symp. Tax, vol 1968. VEB Fischer Verlag, Jena, pp 145–154
- Blunt J, Munro M, Laatsch H (2006) AntiMarin database. University of Canterbury, Christchurch
- Borodovsky M, McIninch J (1993) Recognition of genes in DNA sequence with ambiguities. *Biosystems* 30(1):161–171
- Cerdeño AM, Bibb MJ, Challis GL (2001) Analysis of the prodiginine biosynthesis gene cluster of *Streptomyces Coelicolor* A3 (2): new mechanisms for chain initiation and termination in modular multienzymes. *Chem Biol* 8(8):817–829
- Challis GL (2006) Engineering *Escherichia Coli* to produce nonribosomal peptide antibiotics. *Nat Chem Biol* 2(8):398–400
- Challis GL (2008) Mining microbial genomes for new natural products and biosynthetic pathways. *Microbiology* 154(6):1555–1569
- Chaudhuri RR, Loman NJ, Snyder LA, Bailey CM, Stekel DJ, Pallen MJ (2008) xBASE2: a comprehensive resource for comparative bacterial genomics. *Nucleic Acids Res* 36(suppl 1):D543–D546
- Clos LJ II, Jofre MF, Ellinger JJ, Westler WM, Markley JL (2013) NMRbot: python scripts enable high-throughput data collection on current Bruker BioSpin NMR spectrometers. *Metabolomics* 9(3):558–563
- Corre C, Challis GL (2007) Heavy tools for genome mining. *Chem Biol* 14(1):7–9
- Crevelin E, de Moraes LB, de Melo IS (2010) Mass spectrometry in microbial metabolomic analysis as an analytical tool for dereplication strategy. *Planta Med* 76(12):P545
- Crevelin EJ, Crotti AE, Zucchi TD, Melo IS, Moraes LA (2014) Dereplication of *Streptomyces* sp. AMC 23 polyether ionophore antibiotics by accurate-mass electrospray tandem mass spectrometry. *J Mass Spectrom* 49(11):1117–1126
- Cross T (1981) The monosporic Actinomycetes. In: Starr MP, Stolp H, Trüper HG, Balons A, Schlegel HG (eds) *The Prokaryotes – a handbook on habitats, isolation and identification of bacteria*. Springer Verlag, Berlin, pp 2091–2102
- Cross T (1989) Growth and examination of Actinomycetes-some guidelines. In: Williams ST, Sharpe ME, Holt JG (eds) *Bergey's manual of systematic bacteriology*, vol 4. Williams and Wilkins, Baltimore, pp 2340–2343
- Dashti Y, Grkovic T, Abdelmohsen UR, Hentschel U, Quinn RJ (2014) Production of induced secondary metabolites by a co-culture of sponge-associated actinomycetes, *Actinokineospora* sp. EG49 and *nocardiopsis* sp. RV163. *Mar Drugs* 12(5):3046–3059
- Davis L (2012) *Basic methods in molecular biology*. Elsevier, Amsterdam
- Delcher AL, Harmon D, Kasif S, White O, Salzberg SL (1999) Improved microbial gene identification with GLIMMER. *Nucleic Acids Res* 27(23):4636–4641

- Delcher AL, Bratke KA, Powers EC, Salzberg SL (2007) Identifying bacterial genes and endosymbiont DNA with Glimmer. *Bioinformatics* 23(6):673–679
- Donadio S, Monciardini P, Alduina R, Mazza P, Chiocchini C, Cavaletti L, Sosio M, Puglia AM (2002) Microbial technologies for the discovery of novel bioactive metabolites. *J Biotechnol* 99(3):187–198
- Dorokhova LA, Agre NS, Kalakoutskii LV, Krasil'nikov NA (1969) Fine structure of sporulating hyphae and spores in a thermophilic actinomycete, *Micropolyspora rectivirgula*. *J Microsc* 8:845–854
- Doyle TW, Borders DB (1995) Enediynes antibiotics as antitumor agents. Marcel Dekker, New York
- Drechsler C (1919) Morphology of the genus *Actinomyces* II. *Bot Gaz* 67:147–168
- Duché J (1934) Les actinomyces du groupe *Albus*. *Encycl Mycol* VI:1–375
- Ettlinger L, Corbaz R, Hütter R (1958) Zur Systematik der Actinomyceten. 4. Eine Arzteilung der Gattung *Streptomyces* Waksman und Henricic. *Arch Microbiol* 31:326–358
- Farnet CM, Zazopoulos E (2005) Improving drug discovery from microorganisms. In: *Natural products*. Springer, Totowa, pp 95–106
- Fiehn O (2001) Combining genomics, metabolome analysis, and biochemical modelling to understand metabolic networks. *Comp Funct Genomics* 2(3):155–168
- Fischbach MA, Walsh CT (2006) Assembly-line enzymology for polyketide and nonribosomal peptide antibiotics: logic, machinery, and mechanisms. *Chem Rev* 106(8):3468–3496
- Flaig W, Kutzner H (1960) Beitrag zur Systematik der Gattung *Streptomyces* Waksman und Henrici. *Arch Microbiol* 35:105–138
- Forner D, Berrué F, Correa H, Duncan K, Kerr RG (2013) Chemical dereplication of marine actinomycetes by liquid chromatography–high resolution mass spectrometry profiling and statistical analysis. *Anal Chim Acta* 805:70–79
- Gauze GF, Preobrazhenskaya TP, Kudrina ES, Blinov NO, Ryabova ID, Sveshnikova MA (1957) Problems in the classification of antagonistic actinomycetes. State publishing house for medical literature (in Russian). Medzizg, Moscow
- Gibbs AJ, McIntyre GA (1970) The diagram, a method for comparing sequences. *FEBS J* 16(1):1–11
- Gottlieb D (1961) An evaluation of criteria and procedures in the description and characterization of the *Streptomyces*. *Appl Microbiol* 9:55–65
- Gross H, Stockwell VO, Henkels MD, Nowak-Thompson B, Loper JE, Gerwick WH (2007) The genomisotopic approach: a systematic method to isolate products of orphan biosynthetic gene clusters. *Chem Biol* 14(1):53–63
- Hakvåg S, Fjervik E, Josefsen KD, Ian E, Ellingsen TE, Zotchev SB (2008) Characterization of *Streptomyces* spp. isolated from the sea surface microlayer in the Trondheim fjord, Norway. *Mar Drugs* 6(4):620–635
- Hao C, Huang S, Deng Z, Zhao C, Yu Y (2014) Mining of the pyrrolamide antibiotics analogs in *Streptomyces netropsis* reveals the amidohydrolase-dependent “iterative strategy” underlying the pyrrole polymerization. *PLoS One* 9(6):e99077
- Hara H, Ohnishi Y, Horinouchi S (2009) DNA microarray analysis of global gene regulation by A-factor in *Streptomyces Griseus*. *Microbiology* 155(7):2197–2210
- Haynes SW, Challis GL (2007) Non-linear enzymatic logic in natural product modular megasynthases and-synthetases. *Curr Opin Drug Discov Devel* 10(2):203–218
- Henssen A (1970) Spore formation in thermophilic Actinomycetes. In: Prauser H (ed) *The Actinomycetales*, Jena Int. Symp tax, vol 1968. VEB Fischer Verlag, Jena, pp 205–210
- Hesseltine CW, Benedict RG, Pridham TG (1954) Useful criteria for species differentiation on the genus *Streptomyces*. *Ann N Y Acad Sci* 60:136–151
- Hou Y, Braun DR, Michel CR, Klassen JL, Adnani N, Wyche TP, Bugni TS (2012) Microbial strain prioritization using metabolomics tools for the discovery of natural products. *Anal Chem* 84(10):4277–4283
- Hubert J, Nuzillard JM, Renault JH (2015) Dereplication strategies in natural product research: how many tools and methodologies behind the same concept? *Phytochem Rev* 16:1–41

- Hufsky F, Scheubert K, Böcker S (2014) Computational mass spectrometry for small-molecule fragmentation. *Trends Anal Chem* 53:41–48
- Humble MW, King A, Phillips I (1977) API ZYM: a simple rapid system for the detection of bacterial enzymes. *J Clin Pathol* 30:275–277
- Hütter R (1967) Systematik der Streptomyceten unter besonderer Berücksichtigung der von ihnen gebildeten Antibiotika. *Bibl Microbiol* 6:1–382
- Ito T, Odake T, Katoh H, Yamaguchi Y, Aoki M (2011) High-throughput profiling of microbial extracts. *J Nat Prod* 74(5):983–988
- Jain SK, Pathania AS, Parshad R, Raina C, Ali A, Gupta AP, Kushwaha M, Aravinda S, Bhushan S, Bharate SB (2013) Chrysomycins A–C, antileukemic naphthocoumarins from *Streptomyces sporoverrucosus*. *RSC Adv* 3(43):21046–21053
- Jensen HL (1930) Actinomycetes in Danish soils. *Soil Sci* 30:59–77
- Jeunilaux C (1955) Production of exochitinase by *Streptomyces*. *CR Soc Biol* 149:1307–1308
- Ji Z, Wei S, Zhang J, Wu W, Wang M (2008) Identification of streptothricin class antibiotics in the early-stage of antibiotics screening by electrospray ionization mass spectrometry. *J Antibiot* 61(11):660
- Kameník Z, Hadacek F, Marečková M, Ulanova D, Kopecký J, Chobot V, Plháčková K, Olšovská J (2010) Ultra-high-performance liquid chromatography fingerprinting method for chemical screening of metabolites in cultivation broth. *J Chromatogr A* 1217(51):8016–8025
- Kersten RD, Yang YL, Xu Y, Cimermancic P, Nam SJ, Fenical W, Fischbach MA, Moore BS, Dorrestein PC (2011) A mass spectrometry-guided genome mining approach for natural product peptidogenomics. *Nat Chem Biol* 7(11):794–802
- Kilian M (1978) Rapid identification of Actinomycetaceae and related bacteria. *J Clin Microbiol* 8:127–133
- Kleigrew K, Almaliti J, Tian IY, Kinnel RB, Korobeynikov A, Monroe EA, Duggan BM, Di Marzo V, Sherman DH, Dorrestein PC (2015) Combining mass spectrometric metabolic profiling with genomic analysis: a powerful approach for discovering natural products from cyanobacteria. *J Nat Prod* 78(7):1671–1682
- Krainsky A (1914) Die Aktinomyceten und ihre Bedeutung in der Natur. *Zentralbl Bacteriol Parasitenkd Infektionskr Hyg Abt II* 41:649–688
- Krasil'nikov NA (1941) Guide to the bacteria and Actinomycetes (in Russian). Akad. Nauk SSSR, Moscow
- Krasil'nikov NA (1949) Guide to the bacteria and Actinomycetes. Akad. Nauk SSSR, Moscow
- Krasil'nikov NA (1979) Pigmentation of Actinomycetes and its significance in taxonomy. In: Prauser H (ed) *The Actinomycetales*, Jena Int. Symp. Tax, vol 1968. VEB Fischer Verlag, Jena, pp 123–131
- Küster E (1976) Chromogenicity of Actinomycetes. In: Arai T (ed) *Actinomycetes: the boundary microorganisms*. Toppa Company, Ltd., Tokyo, pp 43–54
- Kutzner HJ (1981) The family Streptomycetaceae. In: Starr MP, Stolp H, Trüper HG, Balons A, Schlegel HG (eds) *The prokaryotes: a handbook on habitats, isolation and identification of bacteria*. Springer Verlag, Berlin, pp 2028–2090
- Kutzner HJ, Kroppenstedt RM, Korn-Wendisch F (1986) Methoden zur Untersuchung von Streptomyceten und einigen anderen Actinomyceten. 4 Auflage. Technische Universität, Darmstadt
- Kuznetsov VD, Yangulova JV (1970) Utilization of medium containing chitin for isolation and quantitative enumeration of actinomycetes from soil. *Microbiologiya* 39:902–906
- Lang G, Mayhudin NA, Mitova MI, Sun L, van der Sar S, Blunt JW, Cole AL, Ellis G, Laatsch H, Munro MH (2008) Evolving trends in the dereplication of natural product extracts: new methodology for rapid, small-scale investigation of natural product extracts. *J Nat Prod* 71(9):1595–1599
- Larsen TS, Krogh A (2003) EasyGene—a prokaryotic gene finder that ranks ORFs by statistical significance. *BMC Bioinformatics* 4(1):1
- Lease RA, Belfort M (2000) A trans-acting RNA as a control switch in *Escherichia Coli*: DsrA modulates function by forming alternative structures. *Proc Natl Acad Sci* 97(18):9919–9924
- Lee PS, Lee KH (2000) Genomic analysis. *Curr Opin Biotechnol* 11(2):171–175



- Liu W, Christenson SD, Standage S, Shen B (2002) Biosynthesis of the enediyne antitumor antibiotic C-1027. *Science* 297(5584):1170–1173
- Locci R (1971) On the spore formation process in Actinomycetes. IV. Examination by scanning electron microscopy of the genera *Thermoactinomyces*, *Actinobifida* and *Thermomonospora*. *Riv Pat Vegetab Suppl* 7:63–80
- MacFaddin JF (1980) *Biochemical tests for the identification of medical bacteria*, 2nd edn. Williams & Wilkins Co., Baltimore
- Macintyre L, Zhang T, Viegelmann C, Martinez IJ, Cheng C, Dowdells C, Abdelmohsen UR, Gernert C, Hentschel U, Edrada-Ebel R (2014) Metabolomic tools for secondary metabolite discovery from marine microbial symbionts. *Mar Drugs* 12(6):3416–3448
- Mahyudin NA, Blunt JW, Cole AL, Munro MH (2012) The isolation of a new S-methyl benzothioate compound from a marine-derived *Streptomyces* sp. *Biomed Res Int* 2012:894708
- Maizel JV, Lenk RP (1981) Enhanced graphic matrix analysis of nucleic acid and protein sequences. *Proc Natl Acad Sci* 78(12):7665–7669
- Malpartida F, Hopwood D (1984) Molecular cloning of the whole biosynthetic pathway of a *Streptomyces* antibiotic and its expression in a heterologous host. *Nat Biotechnol* 309:462–464
- Månsson M, Phipps RK, Gram L, Munro MH, Larsen TO, Nielsen KF (2010) Explorative solid-phase extraction (E-SPE) for accelerated microbial natural product discovery, dereplication, and purification. *J Nat Prod* 73(6):1126–1132
- Markowitz VM, Chen IMA, Palaniappan K, Chu K, Szeto E, Pillay M, Ratner A, Huang J, Woyke T, Huntemann M (2014) IMG 4 version of the integrated microbial genomes comparative analysis system. *Nucleic Acids Res* 42(D1):D560–D567
- Martin JF, Liras P (1989) Organization and expression of genes involved in the biosynthesis of antibiotics and other secondary metabolites. *Annu Rev Microbiol* 43(1):173–206
- Medema MH, Paalvast Y, Nguyen DD, Melnik A, Dorrestein PC, Takano E, Breitling R (2014) Pep2Path: automated mass spectrometry-guided genome mining of peptidic natural products. *PLoS computational biology* 10(9):e1003822
- Miyadoh S, Gakkai NH (1997) *Atlas of Actinomycetes*. Asakura Publishing Co, Tokyo
- Molyneux RJ, Schieberle P (2007) Compound identification: a journal of agricultural and food chemistry perspective. *J Agric Food Chem* 55(12):4625–4629
- Mount DW (2004) *Bioinformatics: sequence and genome analysis*, 2nd edn. Cold Spring Harbour Laboratory Press, Cold Spring Harbour
- Nett M, Ikeda H, Moore BS (2009) Genomic basis for natural product biosynthetic diversity in the actinomycetes. *Nat Prod Rep* 26(11):1362–1384
- Nguyen DD, Wu CH, Moree WJ, Lamsa A, Medema MH, Zhao X, Gavilan RG, Aparicio M, Atencio L, Jackson C (2013) MS/MS networking guided analysis of molecule and gene cluster families. *Proc Natl Acad Sci* 110(28):E2611–E2620
- Nielsen KF, Månsson M, Rank C, Frisvad JC, Larsen TO (2011) Dereplication of microbial natural products by LC-DAD-TOFMS. *J Nat Prod* 74(11):2338–2348
- Nitsch B, Kutzner HJ (1968) Bildung eines melanoiden Pigments durch *Streptomyces griseus* auf synthetischen Medien mit Tyrosin. *Z Naturforsch* 23b:566
- Nitsch B, Kutzner HJ (1973) Wachstum von Streptomyceten in Schüttelagarkulturen: eine neue Methode zur Feststellung des C-Quellen-Spektrums. *Symp Tech Mikrobiol* 3:481–486
- Ohnishi Y, Ishikawa J, Hara H, Suzuki H, Ikenoya M, Ikeda H, Yamashita A, Hattori M, Horinouchi S (2008) Genome sequence of the streptomycin-producing microorganism *Streptomyces Griseus* IFO 13350. *J Bacteriol* 190(11):4050–4060
- Pauli GF, Chen SN, Lankin DC, Bisson J, Case RJ, Chadwick LR, Gödecke T, Inui T, Kronic A, Jaki BU (2014) Essential parameters for structural analysis and dereplication by 1H NMR spectroscopy. *J Nat Prod* 77(6):1473–1487
- Pearson WR, Lipman DJ (1988) Improved tools for biological sequence comparison. *Proc Natl Acad Sci* 85(8):2444–2448
- Pridham TG, Gottlieb D (1948) The utilization of carbon compounds by some Actinomycetales as an aid for species determination. *J Bacteriol* 56:107–114

- Pridham TG, Hesseltine CW, Benedict RG (1958) A guide for the classification of *Streptomyces* according to selected groups. Placement of strains in morphological sections. *Appl Microbiol* 6:52–79
- Proudnikov D, Timofeev E, Mirzabekov A (1998) Immobilization of DNA in polyacrylamide gel for the manufacture of DNA and DNA–oligonucleotide microchips. *Anal Biochem* 259(1):34–41
- Reynolds DM (1954) Exocellular chitinase from *Streptomyces* ssp. *J Gen Microbiol* 11:150–159
- Rick WY, Wang T, Bedzyk L, Croker KM (2001) Applications of DNA microarrays in microbial systems. *J Microbiol Methods* 47(3):257–272
- Ritacco F, Haltli B, Janso J, Greenstein M, Bernan V (2003) Dereplication of *Streptomyces* soil isolates and detection of specific biosynthetic genes using an automated ribotyping instrument. *J Ind Microbiol Biotechnol* 30(8):472–479
- Salzberg SL, Delcher AL, Kasif S, White O (1998) Microbial gene identification using interpolated Markov models. *Nucleic Acids Res* 26(2):544–548
- Schena M, Shalon D, Davis RW, Brown PO (1995) Quantitative monitoring of gene expression patterns with a complementary DNA microarray. *Science* 270(5235):467
- Schiex T, Gouzy J, Moisan A, de Oliveira Y (2003) FrameD: a flexible program for quality check and gene prediction in prokaryotic genomes and noisy matured eukaryotic sequences. *Nucleic Acids Res* 31(13):3738–3741
- Schwecke T, Aparicio JF, Molnar I, König A, Khaw LE, Haydock SF, Oliynyk M, Caffrey P, Cortes J, Lester JB (1995) The biosynthetic gene cluster for the polyketide immunosuppressant rapamycin. *Proc Natl Acad Sci* 92(17):7839–7843
- Shinobu R (1958) Physiological and cultural study for the identification of soil Actinomycetes species. *Mem Osaka Univ Arts Educ B Natur Science* 7:1–76
- Shirling EB, Gottlieb D (1966) Methods for characterization of *Streptomyces* species. *Int J Syst Bacteriol* 16:313–340
- Singh SB, Pelaez F (2008) Biodiversity, chemical diversity and drug discovery. In: Petersen F, Amstutz R (eds) *Natural compounds as drugs*, vol 1. Springer, Basel, pp 141–174
- Sladič G, Urukalo M, Kirn M, Lešnik U, Magdevska V, Benički N, Pelko M, Gasparič A, Raspor P, Polak T (2014) Identification of lipstatin-producing ability in *Streptomyces virginiae* CBS 314.55 using dereplication approach. *Food Technol Biotechnol* 52(3):276–284
- Stafsnes MH, Dybwad M, Brunsvik A, Bruheim P (2013) Large scale MALDI-TOF MS based taxa identification to identify novel pigment producers in a marine bacterial culture collection. *Antonie Van Leeuwenhoek* 103(3):603–615
- Stavri M, Schneider R, O'Donnell G, Lechner D, Bucar F, Gibbons S (2004) The antimicrobial components of hops (*Humulus Lupulus*) and their dereplication. *Phytother Res* 18(9):774–776
- Suter MA (1978) Isolierung von Melanin-negativen Mutanten aus *Streptomyces glaucescens*, vol 6276. Diss ETH Zürich, Zurich
- Tanghe A, Teunissen A, Van Dijck P, Thevelein J (2000) Identification of genes responsible for improved cryoresistance in fermenting yeast cells. *Int J Food Microbiol* 55(1):259–262
- Tresner HD, Backus EJ (1963) System for color wheels for streptomycete taxonomy. *Appl Microbiol* 11:335–338
- Tresner HD, Davies MV, Backus EJ (1961) Electron microscopy of *Streptomyces* spore morphology and its role in species differentiation. *J Bacteriol* 81:70–80
- Van Der Werf MJ, Jellema RH, Hankemeier T (2005) Microbial metabolomics: replacing trial-and-error by the unbiased selection and ranking of targets. *J Ind Microbiol Biotechnol* 32(6):234–252
- Viegelmann C, Margassery LM, Kennedy J, Zhang T, O'Brien C, O'Gara F, Morrissey JP, Dobson AD, Edrada-Ebel R (2014) Metabolomic profiling and genomic study of a marine sponge-associated *Streptomyces* sp. *Mar Drugs* 12(6):3323–3351
- Vobis G (1985) Spore development in sporangia-forming Actinomycetes. In: Szabo G, Biró S, Goodfellow M (eds.), *Proceedings of the Sixth International Symposium on Actinomycetes Biology*, Debrecen, Hungary, 26–30 August, 1985, pp 443–452

- Vobis G, Kothe HW (1985) Sporogenesis in sporangiate Actinomycetes. In: Pathak NC, Singh VP (eds) *Frontiers in applied microbiology*, vol 1. Print House, Lucknow
- Waksman SA (1919) Cultural studies of species of Actinomycetes. *Soil Sci* 8:71–215
- Waksman SA (1961) The Actinomycetes. II. Classification, identification and description of genera and species. The Williams and Wilkins Co., Baltimore, p 363
- Waksman SA, Curtis RE (1916) The actinomycetes of the soil. *Soil Sci I* 1(2):99–134
- Wildermuth H (1972) The surface structure of spores and aerial hyphae in *Streptomyces viridochromogenes*. *Arch Microbiol* 81:309–320
- Williams ST, Bradshaw RM, Colsterton JW, Forge A (1972) Fine structure of the sheath of some *Streptomyces* species. *J Gen Microbiol* 72:249–258
- Williams ST, Goodfellow M, Alderson G (1989) Genus *Streptomyces* Waksman and Henrici 1943, 339<sup>AL</sup>. In: Williams ST, Sharpe ME, Holt JG (eds) *Bergey's manual of systematic bacteriology*, vol 4. Williams and Wilkins, Baltimore, pp 2452–2492
- Williams ST, Wellington EMH (1981) The genera *Actinomadura*, *Actinopolyspora*, *Excillospora*, *Microbispora*, *Micropolyspora*, *Microtetraspora*, *Nocardiopsis*, *Saccharopolyspora*, and *Pseudonocardia*. In: Starr MP, Stolp H, Trüper HG, Balons A, Schlegel HG (eds) *The Prokaryotes: a handbook on habitats, isolation and identification of bacteria*. Springer Verlag, Berlin, pp 2103–2117
- Wink J (2003) Polyphasic taxonomy and antibiotic formation in some closely related genera of the family Pseudonocardiaceae. In: Pandalai SG (ed) *Recent research developments in antibiotics*. Transworld Research Network, Trivandrum, pp 97–140
- Wink J (2016) Compendium of Actinobacteria from Dr. Joachim M. Wink University of Braunschweig Copyright Dr. Joachim M. Wink, Helmholtz-Zentrum für Infektionsforschung <http://www.dsmz.de/bacterial-diversity/compendium-of-actinobacteria.html>
- Wink J, Gandhi J, Kroppenstedt RM, Seibert G, Straubler B, Schumann P, Stackebrandt E (2004) *Amycolatopsis decaplanina* sp. nov., a novel member of the genus with unusual morphology. *Int J Syst Evol Microbiol* 54:235–239
- Witt D, Stackebrandt E (1990) Unification of the genera *Streptoverticillium* and *Streptomyces*, and emendation of *Streptomyces* Waksman and Henrici 1943, 339a. *Syst Appl Microbiol* 13:361–371
- Wolfender JL (2009) HPLC in natural product analysis: the detection issue. *Planta Med* 75(7):719–734
- Xie P, Ma M, Rateb ME, Shaaban KA, Yu Z, Huang SX, Zhao LX, Zhu X, Yan Y, Peterson RM (2014) Biosynthetic potential-based strain prioritization for natural product discovery: a showcase for diterpenoid-producing actinomycetes. *J Nat Prod* 77(2):377–387
- Yang JY, Sanchez LM, Rath CM, Liu X, Boudreau PD, Bruns N, Glukhov E, Wodtke A, De Felicio R, Fenner A (2013) Molecular networking as a dereplication strategy. *J Nat Prod* 76(9):1686–1699
- Zähner H, Ettliger L (1957) Zur Systematik der Aktinomyceten. 3. Die Verwertung verschiedener Kohlenstoffquellen als Hilfsmittel zur Artbestimmung innerhalb der Gattung *Streptomyces*. *Arch Mikrobiol* 26:307–328
- Zazopoulos E, Huang K, Staffa A, Liu W, Bachmann BO, Nonaka K, Ahlert J, Thorson JS, Shen B, Farnet CM (2003) A genomics-guided approach for discovering and expressing cryptic metabolic pathways. *Nat Biotechnol* 21(2):187–190
- Zhao L-X, Huang S-X, Tang S-K, Jiang C-L, Duan Y, Beutler JA, Henrich CJ, McMahon JB, Schmid T, Bles JS (2011) Actinopolysporins A–C and tubercidin as a Pdc4 stabilizer from the halophilic actinomycete *Actinopolyspora erythraea* YIM 90600. *J Nat Prod* 74(9):1990–1995

Naghmeh Poorinmohammad and Javad Hamedí

---

## 12.1 Introduction

Next-generation sequencing (NGS) has made the high-throughput whole genome sequencing affordable and time efficient. Since the late 2000s, there are genome-sequencing projects being increasingly completed and published. According to the Genomes Online Database (GOLD) (Reddy et al. 2014), about 89,832 bacterial samples are reported for sequencing projects, among which 5041 genomes are completed, published, and publicly available via genome databases as of August 2016. To date, from these sequencing projects, 11.5% (10,299 samples) is reported to be belonging to the actinobacterial members (Fig. 12.1) within which there are 557 completed actinobacterial genomes being publicly available.

Although actinobacteria are more biotechnologically relevant in comparison with proteobacteria, the number of their published sequenced genomes shows to be lesser. This is due to the fact that there are several difficulties associated with actinobacterial genome sequencing as well as computing algorithms used for their genome assembly. These difficulties mainly arise from the high mol% G+C content as well as large genome size of these bacteria which affects the genome sequencing quality and completion (Gomez-Escribano et al. 2016). Moreover, the linear chromosome and plasmids of a number of actinobacteria (i.e., streptomycetes), together with the large terminal inverted repeats, make difficulties since they cannot be resolved via current sequencing technologies. Another challenge for actinobacterial genome sequencing is that the extraction of high molecular weight DNA of these bacteria, which should be prepared in high quality required for NGS library

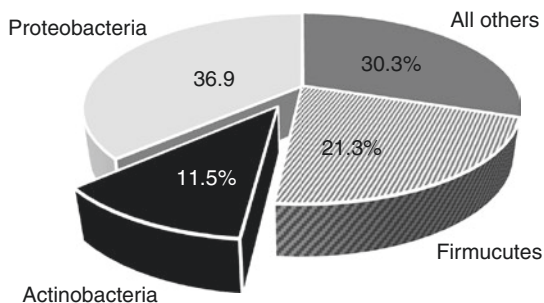
---

N. Poorinmohammad • J. Hamedí (✉)

Department of Microbial Biotechnology, School of Biology and Center of Excellence in Phylogeny of Living Organisms, College of Science, University of Tehran,  
14155-6455 Tehran, Iran

Microbial Technology and Products Research Center, University of Tehran, Tehran, Iran  
e-mail: [jhamedí@ut.ac.ir](mailto:jhamedí@ut.ac.ir)

**Fig. 12.1** Bacterial genome-sequencing projects shared by phylogenetic group (Data adopted from: <https://gold.jgi.doe.gov/statistics>, accessed on August, 2016)



construction, is not yet completely feasible (Gomez-Escribano et al. 2016). In fact, having these hardships for genome sequencing, the share of 11.5% seems to be considerable for actinobacteria.

The large number of completed genomic data via which the information of almost all cellular function can be investigated along with other omics data paves the way for the discovery of new omics and systems-level biological knowledge of interest in actinobacteria. This is complemented specially when coupled with highly efficient computational algorithms and tools. In particular, the approach is held by enabling strategies such as genome mining and systems-level approaches such as systems metabolic engineering and biological network analyses which will be discussed and are the main focus of this chapter.

## 12.2 Genome Mining

Indisputably, the traditional process of discovering new bioactive natural products from microbial sources is time-consuming and laborious with the unfavorable property of having high rates of rediscovery of metabolites (Zerikly and Challis 2009). On the other hand, a widely accepted fact is that bacterial genomes seem to contain many more biosynthetic gene clusters than estimated by the number of natural products discovered experimentally (Duncan et al. 2015). Accordingly, the massive number of publicly accessible microbial complete genomes is being used to mine for novel natural discoveries. This strategy simply implements the computational sequence comparison procedures in order to find genes of the enzymes likely to be involved in the biosynthesis of a natural product of interest located in the sequenced genome or set of genomes. Members of actinobacteria are of the best candidates for genome mining, due to the diverse metabolic potentials reported in these bacteria which are comprehensively discussed in the previous chapters.

It is important to note that the general concept is that only 3% of the natural product potential of even actinobacterial model organisms such as *Streptomyces* has been revealed (Duncan et al. 2015). In this regard, multiple genome mining studies have been performed to date, on different actinobacterial species with the help of accessible complete and annotated genomes. Table 12.1 shows some important

**Table 12.1** Novel natural products discovered via genome mining of some actinobacteria

Actinobacterial species	Genome mining gene target	Metabolite(s) name	Metabolite bioactivity	Reference
<i>Streptomyces coelicolor</i>	Terpene synthase gene cluster	(+)-epi-isozizaene	Antibiotic	Lin et al. (2006)
<i>Streptomyces marokkonensis</i> M10	Polyketide synthase 1 gene cluster	Two polyene metabolites: PF1 and PF2	Antibiotic	Chen et al. (2016)
<i>Salinispora pacifica</i> CNT-133	Salinosporamide biosynthesis gene cluster (Sp_sal)	Salinosporamide K	Anticancer (proteasome inhibitor)	Eustáquio et al. (2011)
<i>Streptosporangium</i> sp. CGMCC 4.7309	<i>hex</i> gene cluster	Hexaricins A–C	–	Tian et al. (2016)
<i>Streptomyces coelicolor</i>	Type III PKSs	Germicidins and isogermicidins	Antibiotic (iron chelator)	Song et al. (2006)
<i>Streptomyces coelicolor</i> M145	Trimodular nonribosomal peptide synthase (NRPS) CchH	Coelichelin	Antibiotic (iron chelator)	Lautru et al. (2005)
<i>Streptomyces avermitilis</i>	<i>sav76</i> (a terpene synthase)	Avermitilol	–	Chou et al. (2010)
<i>Salinispora arenicola</i> CNP193	Esterase gene	A 325-amino-acid esterase (SAestA)	Enzyme with remarkable stability in the presence of organic solvents	Fang et al. (2015)
<i>Streptomyces albus</i> J1074	General genome mining for secondary metabolites	Antimycin, 6-epi-alteramides, candicidin, indigoidine, and paulomycins	–	Olano et al. (2014)

studies of these projects along with their relative metabolites discovered. It is important to note that there are several whole genome annotations within which several predicted metabolite groups are predicted among *Streptomyces* species; however, Table 12.1 summarizes the experimented metabolites.

There are many more studies performed on actinobacterial species that mine their genomes to find novel secondary metabolites; however, many of them report only the novel gene cluster found and do not elucidate the resulting metabolite experimentally. This, however, is due to the fact that many of the predicted natural products through genome mining strategy are cryptic under the research situations. As a result, an important part of genome mining procedure for discovering novel metabolites is to awaken the cryptic gene clusters whose strategies are far from the concept of current chapter and can be reviewed elsewhere (Schlerlach and Hertweck 2009; Baltz 2011; Hu et al. 2011).

Performing genome mining strategies can be specially beneficial if being done on less-studied actinobacteria such as rare or marine actinobacterial species as naïve sources of novel metabolites which have been proven to be greatly potent in this regard (Tiwari and Gupta 2012; Zotchev 2012). As discussed in detail in Chap. 10, *Streptomyces* is the best characterized member of actinobacteria which is also being widely used as an industrial strain for production of more than 50% of commercial antibiotics along with other types of secondary metabolites such as enzyme inhibitors, antifungals, or antitumor agents (Blum et al. 1973; Reading and Cole 1977; Brautaset et al. 2000; Myles 2003). Due to the broad range of research focus to this genus for a long time, search for novel product or potential within this genus does not have much to give. This is of course not true for the newly discovered taxa within this genus as well as the cases in which we are looking for a novel compound in previously studied *Streptomyces* and also performing genome mining on newly published genome sequences of studied streptomycetes. In this regard, Table 12.2 shows the recent genome mining efforts within *Streptomyces* genus in which the discovered metabolites are not necessarily validated experimentally but rather show the importance of the approach in finding new metabolites.

**Table 12.2** Current genome mining studies on *Streptomyces* species

<i>Streptomyces</i> species	Metabolites/potentials	Reference
<i>Streptomyces exfoliatus</i> UC5319 and <i>Streptomyces arenae</i> Tü 469	Cytochrome P450s, CYP-161C3, and CYP161C2, responsible for the final step in the biosynthesis of the sesquiterpenoid antibiotic pentalenolactone	Zhu et al. (2011)
<i>Streptomyces</i> sp. MA37	Fluorinase beneficial in fluorination biotechnology	Deng et al. (2014)
<i>Streptomyces collinus</i> Tü 365	PKS, NRPS, PKS-NRPS hybrids, lanthipeptide, terpenes, and siderophores	Iftime et al. (2016)
<i>Streptomyces wadayamensis</i> A23	Antibiotic biosynthetic pathways	Angolini et al. (2016)
<i>Streptomyces</i> sp. TP-A0356	Polyketide synthases and nonribosomal peptide synthetases	Komaki et al. (2015)
<i>Streptomyces marokkonensis</i> M10	PKS, NRPS, PKS-NRPS hybrids, a lanthipeptide, and terpenes	Chen et al. (2016)
<i>Streptomyces</i> sp. strain CFMR 7	Two latex-clearing protein ( <i>lcp</i> ) genes	Nanthini et al. (2015)
<i>Streptomyces</i> sp. Tü 6176	Nataxazole biosynthesis pathway	Cano-Prieto et al. (2015)
<i>Streptomyces ambofaciens</i> ATCC 23877	PKS, NRPS, PKS-NRPS hybrids, and terpenes	Aigle et al. (2014)
<i>Streptomyces citricolor</i>	Germacradien-4-ol and (–)-epi- $\alpha$ -bisabolol synthases which reveal terpene diversity	Nakano et al. (2011)

Concentrating the post-genomic strategies to discover these potentials is shown to be greatly beneficial if being performed more efficiently on less-explored non-*Streptomyces* (or rare) actinobacteria such as members of the genera *Actinoplanes*, *Micromonospora*, *Microbispora*, *Salinispora*, *Actinomadura*, *Amycolatopsis*, *Kibdelosporangium*, *Kitasatospora*, *Saccharopolyspora*, *Planomonospora*, *Planobispora*, etc. (Lazzarini et al. 2000). There have been genome mining studies in these bacteria due to the availability of the completed genome of several rare actinomycetes. For instance, the 8,212,805 bp-genome of *Saccharopolyspora erythraea* which is currently being used for the industrial-scale production of the antibiotic erythromycin has been analyzed for its secondary metabolism showing more than 20 novel-predicted secondary metabolites (Oliynyk et al. 2007). *Salinispora tropica* – a marine actinobacterium – is another example on which genomic analysis has been done within which several previously non-observed products were predicted through genome mining from polyketides to pigments and a class I bacteriocin. Members of the genera *Frankia*, *Nocardia*, and *Rhodococcus* have been also analyzed, and different novel secondary metabolites (mostly nonribosomal peptides in *Rhodococcus jostii* RHA1) have been identified. Table 12.3 lists some of genome mining studies among rare actinobacteria.

In this regard, increasingly, the genome mining approach to discover secondary metabolism is being performed simultaneously with whole genome sequencing. Although different manual strategies are being implemented through genome mining such as multiple-sequence alignment and search for all the potential gene clusters for secondary metabolites in dozens of newly sequenced genomes, automatic algorithms and more user-friendly in silico procedures are greatly desired. There are tools developed to automatically perform efficient genome mining process which focuses on a specific group of secondary metabolites such as the semiautomated ClustScan (Starcevic et al. 2008), SMURF tool for fungal secondary metabolite biosynthesis gene clusters (Khaldi et al. 2010), and SBSPKS (Anand et al. 2010) and NP.searcher (Li et al. 2009) for PKs and NRPs. However, among these tools, antiSMASH (antibiotics & Secondary Metabolite Analysis Shell) can be implemented via a web server and stand-alone tool to automatically perform the genomic identification and analysis of biosynthetic gene clusters (BGCs) of any type in bacterial and fungal strains (Weber et al. 2015). The pipeline integrates the identification of gene clusters along with the chemical structure prediction which is of great importance. The tool is recently being widely used to discover actinobacterial BGCs from the draft or complete genomes published from these bacteria (Yamamura et al. 2014; Horn et al. 2015; Santos et al. 2015) and is promising for efficient genome mining projects performed on actinobacteria.



**Table 12.3** Predicted metabolite types within non-*Streptomyces* actinobacterial genomes

Non- <i>Streptomyces</i> actinobacteria	Predicted metabolite type	Reference
<i>Saccharopolyspora erythraea</i> NRRL2338	Nonribosomal peptides (NRPs)	Oliynyk et al. (2007)
	Lanthionine-containing peptide	
	Aromatic polyketide	
	Siderophores	
	Polyketides (PKs)	
<i>Salinispora tropica</i> CNB-440	Class I bacteriocin	Udwary et al. (2007)
	Carotenoid pigment	
	Yersiniabactin-like siderophore	
	Polyketide	
	Coelibactin	
<i>Actinoplanes</i> sp. SE50/110	NRPs	Schwientek et al. (2012)
	Polyketides	
	PK-NRP hybrid	
<i>Salinispora arenicola</i> CNS-205	PK-NRP hybrid	Udwary et al. (2007)
	Class I bacteriocin	
	Polyketide	
	Carotenoid pigments	
	Macrolide	
	Siderophore	
<i>Rhodococcus jostii</i> RHA1	Several NRPs	McLeod et al. (2006)
	Polyketides	
	PK-NRP hybrid	
<i>Amycolatopsis orientalis</i> HCCB10007	Polyketides	Xu et al. (2014)
	PK-NRP hybrid	
	Terpenoids	
	Lycopene	
	Carotene	
<i>Kibdelosporangium phytohabitans</i> KLBMP 1111	Several NRPs	Qin et al. (2015)
	Polyketides	
	Hybrid NRPS-PKS	
	Bacteriocin	
<i>Planomonospora sphaerica</i> JCM9374	Lanthionine-containing peptide	Dohra et al. (2016)
	Nonribosomal peptide	
	Bacteriocin	

## 12.3 Systems-Level Approaches

The primary goal of systems biology is to study the systemic properties and dynamic interactions of a biological object. This is performed through the integration of the huge experimental data available in biology, with mathematical modeling of the biological object (e.g., a cell) in the form of a network, since cells are made up of

many chemical components which form networks through their interactions. These networks, thus, have their “nodes” being the chemical components and many “links” describing the interaction of the nodes.

A cell comprises different kinds of networks on the basis of the nature of its nodes and links as well as the specific major function they perform. For instance, *metabolic network* is a network including metabolites as nodes interacting via enzymatic reactions as the links. Other assumed biological networks can be named as *gene regulatory network*, *signaling network*, *protein-protein interaction (PPI) network*, and more comprehensively, the *integrative* or *whole-cell network* which is constructed based on the integration of the data of all possible networks and their interactions which gives a more realistic view of a cell. However, due to the great complexity of a cell, the mathematical calculations for modeling and analysis such networks with high accuracy would be challenging and are yet to be perfectly addressed.

By the way, the first step of conducting a systems-level study on an organism requires an accurate modeled network of interest which itself demands sufficient experimental data as well as data derived from the whole genome of the biological system being studied. This is due to the fact that the information of almost all functions of a cell can be investigated and predicted from the genome data. Therefore, having sufficient omics data, one can think of having a modeled biological network to start the systems-scale analysis. Apparently, this is achieved through high-quality mathematical algorithms and pipelines performed by computational tools.

Herein, an overview of systems-scale approach to actinobacteria is being discussed to summarize the current progress in the field and elucidate the future path. Due to the diverse metabolic and application potentials of these bacteria which have been reviewed in Chap. 10, systems-level study of such bacteria would greatly enhance the resolution of our knowledge about them as well as a rational strategy to improve their potentials as biotechnologically favorable cell factories.

### 12.3.1 Metabolic Model Analysis

Since secondary metabolites are not involved in the growth of the host cell, it is produced in the scale of  $\mu\text{g}$  to  $\text{mg/L}$  which is sufficient for giving the strain a kind of selective advantage. On the other hand, industrial production of these compounds must be in the scale of  $\text{g/L}$ , and thus, the natural amount of secondary metabolites is much far from being industrially relevant. Classically, there have been different strategies implemented for strain improvement, such as screening for the highest-producing wild strain or performing random mutagenesis or protoplast fusion and then select the overproducing strain. However, by the introduction of recombinant DNA (rDNA) technology in 1972, the microbial biotechnology has been revived due to its capability of directed mutagenesis to improve the yields. The advancement of this technology has also allowed the emergence of the field of *metabolic engineering*.

Generally, in the era of rDNA technology, a secondary metabolite has been overproduced by deregulating the enzymatic pathway directly associated with its

biosynthesis, or it was performed by cloning the genes of the metabolite biosynthesis in a robust host organism such as *Escherichia coli*. Although higher yields were achieved for many metabolites through this strategy, the approach was not always successful due to the concept of metabolic network rigidity. This phenomenon is defined by the fact that there are strict mechanisms for controlling enzyme activity which has been evolved in order to maintain the carbon flux distribution in a way which is optimal for the growth of the organism. However, we must radically redirect the carbon flux distributions at key branch points in the primary metabolism, such as in glycolysis or pentose phosphate pathways as well as tricarboxylic acid (TCA) cycle to obtain the objective target of increasing yields of a specific secondary metabolite. Therefore, due to this nonlinear and complex nature of the metabolic control architectures, some other systemic insights must be gained rather than merely being able to perform rational genetic manipulations (Tethnol et al. 1984; Stephanopoulos 1999). Accordingly metabolic engineering has been introduced in the late 1990s to overcome the problem by genetic modification of a specific node in the primary metabolism for the purpose of enhancing the yield and productivity by enhancing the precursor supply, reducing flux toward competing pathways or unwanted by-products, overexpression of bottleneck enzymes, as well as amplifying the target gene cluster or heterologous expression of the whole biosynthetic pathway (Zabala et al. 2013; Bilyk and Luzhetskyy 2016). Mostly, a combination of these strategies can result better outputs. For instance, the production of mithramycin, a polyketide antitumor compound produced by *Streptomyces argillaceus*, was enhanced via metabolic engineering through multiple strategies: overexpressing either the phosphoglucomutase gene or the acetyl-CoA carboxylase gene in order to enhance the intracellular concentrations of glucose-1-phosphate and malonyl-CoA, respectively, as precursors as well as inactivating ADP-glucose pyrophosphorylase and acyl-CoA:diacylglycerol acyltransferase which also lead to the increase of the mentioned precursors. The study showed that each single alteration has led to the increase in mithramycin production; however, the combination of different strategies was the best for increasing mithramycin production (Zabala et al. 2013).

Due to the importance and variety of primary and secondary metabolism in actinobacteria, these bacteria were of the primary choices which undergone metabolic engineering approach, among which *Corynebacterium glutamicum* was of the very first actinobacteria, metabolically engineered to enhance its amino acid production (Ikeda and Katsumata 1992; Ikeda et al. 1993; Vallino and Stephanopoulos 1993). Table 12.4 lists other metabolically engineered actinobacteria for the improvement of productivity and yield.

It is important to note that the main step of performing this metabolic engineering approach is to elucidate the set of integrated pathways used in the biosynthesis of the interested metabolite to further analyze the flux distribution within these pathways. Metabolic flux analysis was performed using in vivo experimental methods such as isotope labeling to track the flux (Stephanopoulos 1999). Via this strategy, cells are cultivated using, e.g.,  $^{13}\text{C}$  isotope substrates, and then the distribution of isotopes in

**Table 12.4** Some of the important metabolic engineering tasks on actinobacterial species for yield improvement

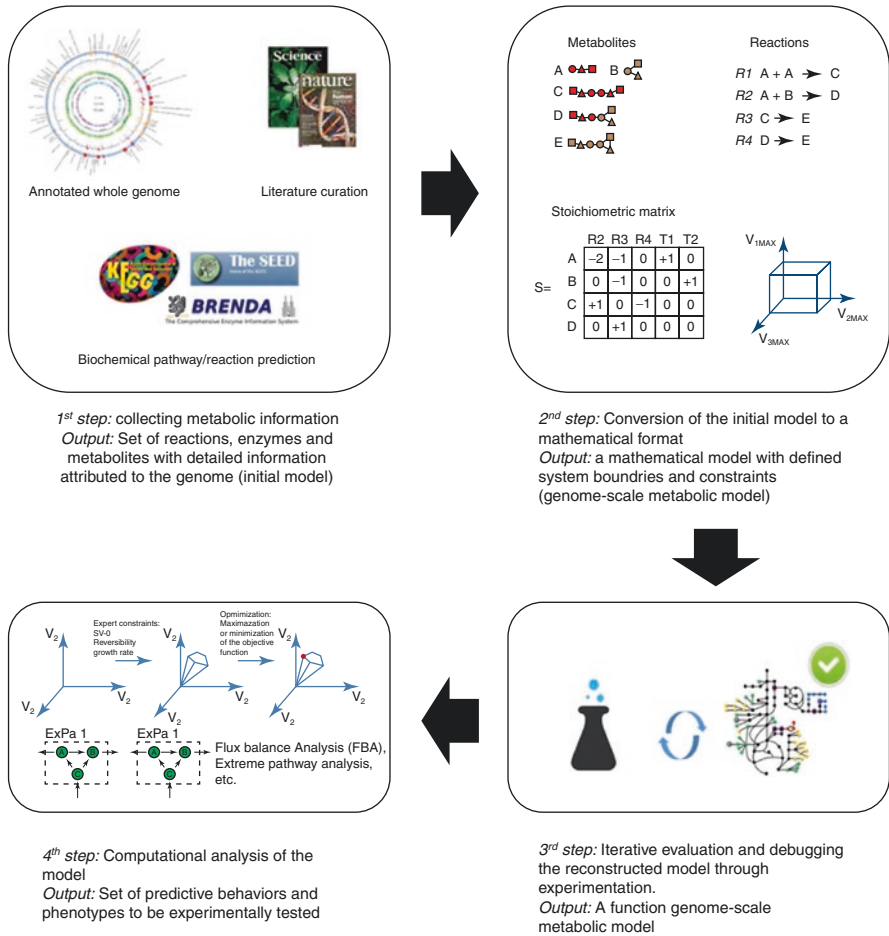
Actinobacteria	Target metabolite	Metabolite activity	Yield increase	Reference
<i>Streptomyces argillaceus</i>	Mithramycin	Antitumor	229%	Zabala et al. (2013)
<i>Streptomyces venezuelae</i>	Tylactone	Antibiotic	Tenfold	Jung et al. (2014)
<i>Streptomyces roseosporus</i>	Oxytetracycline	Antibiotic		Tang et al. (2011)
<i>Corynebacterium glutamicum</i>	Triacylglycerols	Nutritional lipid		
<i>Amycolatopsis</i> sp. strain ATCC 39116	Vanillin	Flavor	Fourfold	Fleige et al. (2016)
<i>Streptomyces coelicolor</i>	Actinorhodin	Antibiotic	Sixfold	Ryu et al. (2006)
<i>Streptomyces coelicolor</i> M512	Elloramycin	Antibiotic	8–26-fold	Freitag et al. (2006)
<i>Saccharopolyspora spinosa</i>	Spinosyns	Insecticidal	7.44–8.03-fold	Jha et al. (2014)
<i>Streptomyces clavuligerus</i>	Clavulanic acid	Antibiotic	Twofold	Li and Townsend (2006)
<i>Streptomyces peuceitius</i>	Doxorubicin	Antitumor	Fourfold	Niraula et al. (2010)

the metabolites is measured by analytical methods such as GC-MS or  $^{13}\text{C}$ -NMR which is further analyzed using computational algorithms to find intracellular fluxes. Metabolic engineering can then be performed via analysis of the output. However, an inherent problem with this strategy is the high cost and the expertise needed to perform the experimental procedures (Woolston et al. 2013). Accordingly, there are currently purely computational methods by which the flux analysis can be performed along with giving metabolic engineering a more holistic view with lower costs and time via the introduction of genome-scale metabolic model reconstructions and its further analysis strategies such as flux balance analysis (FBA) which are totally performed in silico. Therefore, systems biology is currently playing a crucial role in metabolic engineering by altering the metabolic flux distribution within an interested organism based on systematic strategies. Accordingly, with multiple microorganisms being sequenced, the reconstruction of a genome-scale metabolic model to gain comprehensive insight into microbial physiology is getting important.

As discussed before, the development of high-throughput techniques for deciphering genomes, transcriptomes, proteomes, and metabolomes together with computational tools and algorithms has paved the way for the emergence of systems-level concept in biology. Having this information, the interactions of biomolecules can be explored and used to model the network in which they work together. In this regard, reconstruction and study of metabolic networks using the genome and metabolome

data and in order to reveal the systems behavior of metabolism enable us to rationally manipulate these interactions for improving the strain in a desired way.

Currently, genome-scale metabolic models are generally reconstructed using the gene annotation data coupled with information about the reactions from available databases which attribute the known phenotype-genotype relationship to the genome of interest, and then this set of attributed reactions is converted to mathematical representation to achieve a computationally analyzable model. The overall work flow for genome-scale metabolic model reconstruction is depicted in Fig. 12.2.



**Fig. 12.2** The general overview of genome-based metabolic model reconstruction for further analysis

If the reconstructed models are proved to be accurate enough after relevant validations, the models can be efficiently used to study the systems behavior of the metabolism and find hotspots whose manipulation will result in the improved phenotype of interest (Oberhardt et al. 2009). Accordingly, the mathematical functional model will be implemented to perform often a linear programming procedure to find the optimal solution to our biological problem which is called an objective function. In the case of industrially important actinobacteria, the objective function could be maximizing the yield and productivity of a desired production and also growth rate of the strain, as well as minimizing the growth rate in case of pathogenic actinobacteria, although, the global analysis and study of the topological properties of the network can be also helpful especially in comparative studies. The optimization through this approach is mainly performed via a fully computational method called FBA. FBA calculates the flow of metabolites through the reconstructed metabolic network using defined constraints, and thus the maximum or minimum flow of metabolites can be calculated. Growth rate can also be analyzed through this method by introducing a reaction called biomass reaction to the model (Orth et al. 2010).

After the comprehensive computational analysis, strain improvement can be performed. This process being regarded to as “systems metabolic engineering” is being increasingly used in microbial biotechnology to enhance secondary metabolite production and development of cell factories, understanding the biology of microorganisms in systems level or finding drug targets in terms of pathogenic microorganisms.

Since actinobacteria comprise both pathogenic and biotechnologically important strains, the systems metabolic engineering can greatly help in all mentioned fields. In the past 10 years, multiple actinobacterial metabolic models have been reconstructed and implemented for systems metabolic engineering. Among these efforts, systems metabolic engineering of *Corynebacterium glutamicum* to enhance the production of amino acids has shown great promises such as achievement of up to 120 g/L lysine production (Becker et al. 2011). Another widely studied application of systems metabolic engineering in actinobacteria is to enhance antibiotic production especially in *Streptomyces* species (Kim et al. 2014). Table 12.5 lists the actinobacterial members whose genome-scale metabolic models have been reconstructed as of August 2016, along with the relevant application of the metabolic model analysis.

As mentioned before, there are currently more than 550 actinobacterial genomes available using which genome-scale metabolic models can be reconstructed at least those which have been studied in terms of physiology and metabolism. With the great pace in this era of research, it is predicted to have more metabolic models of actinobacteria by which the systems-level optimizations for biotechnological productions can be performed more feasibly.

**Table 12.5** Actinobacteria with reconstructed genome-scale metabolic network

Actinobacterial species	Model main application	Strategy	Reference
<i>Saccharopolyspora erythraea</i>	Enhancing erythromycin production	Maximizing growth rate in a constraint glucose uptake rate	Licona-Cassani et al. (2012)
<i>Mycobacterium tuberculosis</i>	Study the metabolism during infection	Predictions of gene essentiality to identify drug target candidates	Beste et al. (2007)
<i>Streptomyces coelicolor</i> A3(2)	Antibiotic production	Maximizing antibiotic production rate under limited glucose consumption rate and constrained biomass formation rate	Kim et al. (2014)
<i>Rhodococcus erythropolis</i>	Bioremediation and fuel desulfurization	Simulate growth in the absence of one component at a time to define minimal medium	Aggarwal et al. (2011)
<i>Corynebacterium glutamicum</i>	Amino acid production	Maximizing for lysine production and constraining biomass production at different levels	Kjeldsen and Nielsen (2009)
<i>Salinispora tropica</i> CNB-440	Study strain-specific adaptation	Determine growth rates for each medium condition one at a time to predict the strain's capacity to use a range of compounds as nutrients under minimal conditions	Contador et al. (2015)
<i>Bifidobacterium adolescentis</i> L2-32	Study gut microbiota interactions	Maximizing growth in different carbon sources	El-Semman et al. (2014)
<i>Streptomyces clavuligerus</i>	Antibiotic production	Gene knockout simulation under minimal medium condition	Medema et al. (2010)
<i>Streptomyces lividans</i> TK24	Heterologous protein production	Minimization of the total sum of absolute fluxes and the number of nonzero reactions and maximization of ATP yield per flux unit	D'Huys et al. (2012)
<i>Streptomyces roseosporus</i>	Daptomycin production	Maximization of daptomycin biosynthesis rate and specific growth rate	Huang et al. (2012)

### 12.3.2 Other Biological Network Analysis

The expression and transcription of enzymes responsible for the production of metabolites and advancement of the metabolic pathways are strictly regulated via various regulation procedures to maximize species competitiveness, and thus, the output is not always favorable for industrially relevant production. Moreover, regulatory mechanisms are interesting targets for therapeutic applications in the case of pathogenic bacteria. Therefore, understanding the regulatory mechanisms of bacteria in a systems view can perfectly complement the metabolic model analysis and engineering.

In bacteria, the transcriptional regulation is the most dominant gene regulation strategy for secondary metabolism where the regulation of sets of genes is coordinated by an operator which results in the operon organization in the bacterial genomes. These operons and genes can be under control of the same set of transcription factors (TFs) which then are called regulons (Liu et al. 2016). To study the mechanism of transcriptional regulation systematically, we need to identify these regulons and their relevant TFs which can lead to the construction of transcriptional regulatory network of the bacteria. To perform a genome-scale transcriptional regulation network modeling, after collecting the TF repertoire of the organism of interest via comparative genomics (required the whole genome) or proteomics assays (can be performed experimentally through high-throughput (HT) techniques or by performing literature survey), the transcription binding site relevant to each TF is also analyzed, and the overall network is graphically visualized using appropriate tools. There are also automated tools which computationally perform these steps as well as the regulon prediction such as PePPER (de Jong et al. 2012), RegPrecise (Novichkov et al. 2012), etc. After the integration of complementary data such as regulatory RNAs and completion of the final network which enhances the quality of the network, it can be converted to a mathematical model (as seen in the previous section) in order to make it computer readable and perform different analysis computationally. Moreover, these data can be mapped and integrated into metabolic models to improve model predictions and performance (Faria et al. 2014).

Although the field is much younger than metabolic modeling among actinobacterial members, there are species studied for their transcriptional regulatory networks such as *Corynebacterium glutamicum* (Schröder and Tauch 2013), *Mycobacterium tuberculosis* (Balázs et al. 2013), and *Corynebacterium jeikeium* K411 (Barzantny et al. 2012). The main application of these regulatory networks in the near future is believed to be mainly in activating silent BGCs especially among actinobacteria which comprise various yet-to-be-discovered secondary metabolites. Through systems understanding of the regulation on these BGCs, further strategies can be designed to activate the expression of these clusters which will lead to novel natural product discovery.



As a post-genomic era interest, the thorough knowledge of interactions between proteins in a given cell, whether direct or indirect, can provide a comprehensive description of cellular functions. For instance, the systematic study of signal transduction is greatly dependent on the investigation of the interactions among its contributed proteins. Protein-protein interaction (PPI) analysis is also helpful in studying the metabolism as in many biosynthetic processes enzymes interact with each other to produce their products.

Studying this phenomenon in systems level requires the construction of PPI network which gives the deep insight to the biological detail of such procedures. Studying the way in which one protein recognizes and binds to another protein in order to regulate its function in a holistic manner is helpful especially for drug target discovery and better understanding of the biological process behind the pathogenicity and virulence pathways. Therefore, not surprisingly, the PPI network study among actinobacteria is mostly performed on the pathogenic members such as *Mycobacterium tuberculosis*. Although sporadic data on the interaction between small number of actinobacterial proteins can be found in PPI databases such as STRING (Franceschini et al. 2013), the *M. tuberculosis* is the only actinobacterium whose PPI network is constructed based on HT method of bacterial two-hybrid and is available for further analysis specially the studies with their aim being on drug target discovery (Wang et al. 2010). Accordingly, similar data must be generated for biotechnological procedures using which the study of functional cellular metabolism in protein level can gain deep insights for the optimization of the strain and its production potentials.

It is important to note that implementing any type of HT data and their integration to biomolecular networks of the interested bacteria would greatly enhance the research vision as it gives a more realistic picture of the organism but is the yet-to-be-performed strategy on actinobacteria since there are limitations in accessing the HT omics data of these bacteria in comparison to bacterial model organisms such *E. coli* or *B. subtilis*.

---

## 12.4 Future Perspective

The systems-level research still covers a very small fraction of actinobacterial studies especially in the field of regulatory and integrative biomolecular network reconstruction and analysis. Although there is a great interest and output lie in performing such studies, it should be kept in mind that there is no other solution than performing HT experiments in order to yield sufficient high-quality data required for network reconstruction. Moreover, literature survey and text mining are of great importance when a high-quality model is desired.

All in all, an apparent shift from a component-based perspective to a systems-level view of biological systems is occurring which is the result of our ability in extensively producing HT data. Actinobacterial research is not an exception in this matter. Due to their great importance in key biotechnological productions as well as critical roles in medical bacteriology in the future, network

reconstructions and systems-scale study of these organisms are expected to dominate the research and industry resulting in a comprehensive rational design of cell factories as well as therapeutic strategies. Accordingly, the integrative biomolecular networks which comprise at the same time, metabolome, transcriptome, proteome, and even signaling and regulating small molecules are the favorable type of network to be analyzed which undoubtedly will become available due to the accelerated pace of HTdata generation and computational tools. Finally, it is important to remind that actinobacterial post-genomic research and systems-level studies depend strongly on more HT data to be able to efficiently step into this field with promising outputs.

---

## References

- Aggarwal S, Karimi I, Lee DY (2011) Reconstruction of a genome-scale metabolic network of *Rhodococcus erythropolis* for desulfurization studies. *Mol BioSyst* 7(11):3122–3131
- Aigle B, Lautru S, Spitteller D, Dickschat JS, Challis GL, Leblond P, Pernodet J-L (2014) Genome mining of *Streptomyces ambofaciens*. *J Ind Microbiol Biotechnol* 41(2):251–263
- Anand S, Prasad MR, Yadav G, Kumar N, Shehara J, Ansari MZ, Mohanty D (2010) SBSPKS: structure based sequence analysis of polyketide synthases. *Nucleic acids Res* 38:W487–W496
- Angolini CF, Gonçalves AB, Sigrist R, Paulo BS, Samborsky M, Cruz PL, Vivian AF, Schmidt EM, Eberlin MN, Araújo WL (2016) Genome Mining of Endophytic *Streptomyces wadayaensis* Reveals High Antibiotic Production Capability. *J Braz Chem Soc* 27(8):1465–1475
- Balázsi G, Igoshin OA, Gennaro ML (2013) The transcriptional regulatory network of mycobacterium tuberculosis. In: *Bacterial gene regulation and transcriptional networks*, vol 185–198
- Baltz RH (2011) Strain improvement in actinomycetes in the postgenomic era. *J Ind Microbiol Biotechnol* 38(6):657–666
- Barzantny H, Schröder J, Strotmeier J, Fredrich E, Brune I, Tauch A (2012) The transcriptional regulatory network of *Corynebacterium jeikeium* K411 and its interaction with metabolic routes contributing to human body odor formation. *J Biotechnol* 159(3):235–248
- Becker J, Zelder O, Häfner S, Schröder H, Wittmann C (2011) From zero to hero—Design-based systems metabolic engineering of *Corynebacterium glutamicum* for L-lysine production. *Metab Eng* 13(2):159–168
- Beste DJ, Hooper T, Stewart G, Bonde B, Avignone-Rossa C, Bushell ME, Wheeler P, Klamt S, Kierzek AM, McFadden J (2007) GSMN-TB: a web-based genome-scale network model of *Mycobacterium tuberculosis* metabolism. *Genome Biol* 8(5):1
- Bilyk O, Luzhetskyy A (2016) Metabolic engineering of natural product biosynthesis in actinobacteria. *Curr Opin Biotechnol* 42:98–107
- Blum RH, Carter SK, Agre K (1973) A clinical review of bleomycin—a new antineoplastic agent. *Cancer* 31(4):903–914
- Brautaset T, Sekurova ON, Sletta H, Ellingsen TE, Strøm AR, Valla S, Zotchev SB (2000) Biosynthesis of the polyene antifungal antibiotic nystatin in *Streptomyces noursei* ATCC 11455: analysis of the gene cluster and deduction of the biosynthetic pathway. *Chem Biol* 7(6):395–403
- Cano-Prieto C, García-Salcedo R, Sánchez-Hidalgo M, Braña AF, Fiedler HP, Méndez C, Salas JA, Olano C (2015) Genome Mining of *Streptomyces* sp. Tü 6176: characterization of the nataxazole biosynthesis pathway. *ChemBioChem* 16(10):1461–1473
- Chen L, Lai Y-M, Yang Y-L, Zhao X (2016) Genome mining reveals the biosynthetic potential of the marine-derived strain *Streptomyces marokkonensis* M10. *Synthetic Syst Biotechnol* 1(1):56–65

- Chou WK, Fanizza I, Uchiyama T, Komatsu M, Ikeda H, Cane DE (2010) Genome mining in *Streptomyces avermitilis*: cloning and characterization of SAV\_76, the synthase for a new sesquiterpene, avermitilol. *J Am Chem Soc* 132(26):8850–8851
- Contador C, Rodríguez V, Andrews B, Asenjo J (2015) Genome-scale reconstruction of *Salinispora tropica* CNB-440 metabolism to study strain-specific adaptation. *Antonie Van Leeuwenhoek* 108(5):1075–1090
- D’Huys P-J, Lule I, Vercammen D, Anné J, Van Impe JF, Bernaerts K (2012) Genome-scale metabolic flux analysis of *Streptomyces lividans* growing on a complex medium. *J Biotechnol* 161(1):1–13
- de Jong A, Pietersma H, Cordes M, Kuipers OP, Kok J (2012) PePPER: a webserver for prediction of prokaryote promoter elements and regulons. *BMC Genomics* 13(1):299
- Deng H, Ma L, Bandaranayaka N, Qin Z, Mann G, Kyeremeh K, Yu Y, Shepherd T, Naismith JH, O’Hagan D (2014) Identification of fluorinases from *Streptomyces* sp MA37, *Nocardia brasiliensis*, and *Actinoplanes* sp N902-109 by Genome Mining. *ChemBioChem* 15(3):364–368
- Dohra H, Suzuki T, Inoue Y, Kodani S (2016) Draft genome sequence of *Planomonospora sphaerica* JCM 9374, a rare actinomycete. *Genome Announc* 4(4):e00779–e00716
- Duncan KR, Crüsemann M, Lechner A, Sarkar A, Li J, Ziemert N, Wang M, Bandeira N, Moore BS, Dorrestein PC (2015) Molecular networking and pattern-based genome mining improves discovery of biosynthetic gene clusters and their products from *Salinispora* species. *Chem Biol* 22(4):460–471
- El-Semman IE, Karlsson FH, Shoae S, Nookaew I, Soliman TH, Nielsen J (2014) Genome-scale metabolic reconstructions of *Bifidobacterium adolescentis* L2-32 and *Faecalibacterium prausnitzii* A2-165 and their interaction. *BMC Syst Biol* 8(1):1
- Eustáquio AS, Nam SJ, Penn K, Lechner A, Wilson MC, Fenical W, Jensen PR, Moore BS (2011) The discovery of salinosporamide K from the marine bacterium “*Salinispora pacifica*” by genome mining gives insight into pathway evolution. *ChemBioChem* 12(1):61–64
- Fang Y, Wang S, Liu S, Jiao Y (2015) Discovery a novel organic solvent tolerant esterase from *Salinispora arenicola* CNP193 through genome mining. *Int J Biol Macromol* 80:334–340
- Faria JP, Overbeek R, Xia F, Rocha M, Rocha I, Henry CS (2014) Genome-scale bacterial transcriptional regulatory networks: reconstruction and integrated analysis with metabolic models. *Brief Bioinform* 15(4):592–611
- Fleige C, Meyer F, Steinbüchel A (2016) Metabolic Engineering of the Actinomycete *Amycolatopsis* sp. Strain ATCC 39116 towards Enhanced Production of Natural Vanillin. *Appl Environ Microbiol* 82(11):3410–3419
- Franceschini A, Szklarczyk D, Frankild S, Kuhn M, Simonovic M, Roth A, Lin J, Minguez P, Bork P, Von Mering C (2013) STRING v9. 1: protein-protein interaction networks, with increased coverage and integration. *Nucleic Acids Res* 41(D1):D808–D815
- Freitag A, Méndez C, Salas JA, Kammerer B, Li S-M, Heide L (2006) Metabolic engineering of the heterologous production of clorobiocin derivatives and elloramycin in *Streptomyces coelicolor* M512. *Metab Eng* 8(6):653–661
- Gomez-Escribano JP, Alt S, Bibb MJ (2016) Next Generation Sequencing of Actinobacteria for the Discovery of Novel Natural Products. *Mar Drugs* 14(4):78
- Horn H, Cheng C, Edrada-Ebel R, Hentschel U, Abdelmohsen UR (2015) Draft genome sequences of three chemically rich actinomycetes isolated from Mediterranean sponges. *Mar Genomics* 24:285–287
- Hu Y, Chou WK, Hopson R, Cane DE (2011) Genome mining in *Streptomyces clavuligerus*: Expression and biochemical characterization of two new cryptic sesquiterpene synthases. *Chem Biol* 18(1):32–37
- Huang D, Wen J, Wang G, Yu G, Jia X, Chen Y (2012) In silico aided metabolic engineering of *Streptomyces roseosporus* for daptomycin yield improvement. *Appl Microbiol Biotechnol* 94(3):637–649
- Iftime D, Kulik A, Härtner T, Rohrer S, Niedermeyer THJ, Stegmann E, Weber T, Wohlleben W (2016) Identification and activation of novel biosynthetic gene clusters by genome mining in the kirromycin producer *Streptomyces collinus* Tü 365. *J Ind Microbiol Biotechnol* 43(2–3):277–291

- Ikeda M, Katsumata R (1992) Metabolic engineering to produce tyrosine or phenylalanine in a tryptophan-producing *Corynebacterium glutamicum* strain. *Appl Environ Microbiol* 58(3):781–785
- Ikeda M, Ozaki A, Katsumata R (1993) Phenylalanine production by metabolically engineered *Corynebacterium glutamicum* with the *pheA* gene of *Escherichia coli*. *Appl Microbiol Biotechnol* 39(3):318–323
- Jha AK, Pokhrel AR, Chaudhary AK, Park S-W, Cho WJ, Sohng JK (2014) Metabolic engineering of rational screened *Saccharopolyspora spinosa* for the enhancement of spinosyns A and D production. *Mol Cells* 37(10):727
- Jung WS, Kim E, Yoo YJ, Ban YH, Kim EJ, Yoon YJ (2014) Characterization and engineering of the ethylmalonyl-CoA pathway towards the improved heterologous production of polyketides in *Streptomyces venezuelae*. *Appl Microbiol Biotechnol* 98(8):3701–3713
- Khalidi N, Seifuddin FT, Turner G, Haft D, Nierman WC, Wolfe KH, Fedorova ND (2010) SMURF: genomic mapping of fungal secondary metabolite clusters. *Fungal Genet Biol* 47(9):736–741
- Kim M, Sang Yi J, Kim J, Kim JN, Kim MW, Kim BG (2014) Reconstruction of a high-quality metabolic model enables the identification of gene overexpression targets for enhanced antibiotic production in *Streptomyces coelicolor* A3 (2). *Biotechnol J* 9(9):1185–1194
- Kjeldsen KR, Nielsen J (2009) In silico genome-scale reconstruction and validation of the *Corynebacterium glutamicum* metabolic network. *Biotechnol Bioeng* 102(2):583–597
- Komaki H, Ichikawa N, Hosoyama A, Fujita N, Igarashi Y (2015) Draft Genome Sequence of *Streptomyces* sp. TP-A0356, a Producer of Yatakemycin. *Genome Announc* 3(6):e01446–e01415
- Lautru S, Deeth RJ, Bailey LM, Challis GL (2005) Discovery of a new peptide natural product by *Streptomyces coelicolor* genome mining. *Nat Chem Biol* 1(5):265–269
- Lazzarini A, Cavaletti L, Toppo G, Marinelli F (2000) Rare genera of actinomycetes as potential producers of new antibiotics. *Antonie Van Leeuwenhoek* 78(3–4):399–405
- Li R, Townsend CA (2006) Rational strain improvement for enhanced clavulanic acid production by genetic engineering of the glycolytic pathway in *Streptomyces clavuligerus*. *Metab Eng* 8(3):240–252
- Li MH, Ung PM, Zajkowski J, Garneau-Tsodikova S, Sherman DH (2009) Automated genome mining for natural products. *BMC Bioinformatics* 10(1):1
- Licona-Cassani C, Marcellin E, Quek L-E, Jacob S, Nielsen LK (2012) Reconstruction of the *Saccharopolyspora erythraea* genome-scale model and its use for enhancing erythromycin production. *Antonie Van Leeuwenhoek* 102(3):493–502
- Lin X, Hopson R, Cane DE (2006) Genome Mining in *Streptomyces coelicolor*: Molecular Cloning and Characterization of a New Sesquiterpene Synthase. *J Am Chem Soc* 128(18):6022–6023
- Liu B, Zhou C, Li G, Zhang H, Zeng E, Liu Q, Ma Q (2016) Bacterial regulon modeling and prediction based on systematic cis regulatory motif analyses. *Sci Rep* 6:23030
- McLeod MP, Warren RL, Hsiao WW, Araki N, Myhre M, Fernandes C, Miyazawa D, Wong W, Lillquist AL, Wang D (2006) The complete genome of *Rhodococcus* sp. RHA1 provides insights into a catabolic powerhouse. *Proc Natl Acad Sci* 103(42):15582–15587
- Medema MH, Trefzer A, Kovalchuk A, van den Berg M, Müller U, Heijne W, Wu L, Alam MT, Ronning CM, Nierman WC (2010) The sequence of a 1.8-Mb bacterial linear plasmid reveals a rich evolutionary reservoir of secondary metabolic pathways. *Genome Biol Evol* 2:212–224
- Myles DC (2003) Novel biologically active natural and unnatural products. *Curr Opin Biotechnol* 14(6):627–633
- Nakano C, Kudo F, Eguchi T, Ohnishi Y (2011) Genome Mining Reveals Two Novel Bacterial Sesquiterpene Cyclases:(-)-Germacradien-4-ol and (-)-epi- $\alpha$ -Bisabolol Synthases from *Streptomyces citricolor*. *ChemBioChem* 12(15):2271–2275
- Nanthini J, Chia K-H, Thottathil GP, Taylor TD, Kondo S, Najimudin N, Baybayan P, Singh S, Sudesh K (2015) Complete genome sequence of *Streptomyces* sp. strain CFMR 7, a natural rubber degrading actinomycete isolated from Penang, Malaysia. *J Biotechnol* 214:47–48
- Niraula NP, Kim S-H, Sohng JK, Kim E-S (2010) Biotechnological doxorubicin production: pathway and regulation engineering of strains for enhanced production. *Appl Microbiol Biotechnol* 87(4):1187–1194

- Novichkov PS, Brettin TS, Novichkova ES, Dehal PS, Arkin AP, Dubchak I, Rodionov DA (2012) RegPrecise web services interface: programmatic access to the transcriptional regulatory interactions in bacteria reconstructed by comparative genomics. *Nucleic Acids Res* 40(W1):W604–W608
- Oberhardt MA, Palsson BØ, Papin JA (2009) Applications of genome-scale metabolic reconstructions. *Mol Syst Biol* 5(1):320
- Olano C, García I, González A, Rodríguez M, Rozas D, Rubio J, Sánchez-Hidalgo M, Braña AF, Méndez C, Salas JA (2014) Activation and identification of five clusters for secondary metabolites in *Streptomyces albus* J1074. *Microb Biotechnol* 7(3):242–256
- Oliynyk M, Samborsky M, Lester JB, Mironenko T, Scott N, Dickens S, Haydock SF, Leadlay PF (2007) Complete genome sequence of the erythromycin-producing bacterium *Saccharopolyspora erythraea* NRRL23338. *Nat Biotechnol* 25(4):447–453
- Orth JD, Thiele I, Palsson BØ (2010) What is flux balance analysis? *Nat Biotechnol* 28(3):245–248
- Qin S, Feng W-W, Xing K, Bai J-L, Yuan B, Liu W-J, Jiang J-H (2015) Complete genome sequence of *Kibdelosporangium phytohabitans* KLBMP 1111 T, a plant growth promoting endophytic actinomycete isolated from oil-seed plant *Jatropha curcas* L. *J Biotechnol* 216:129–130
- Reading C, Cole M (1977) Clavulanic acid: a beta-lactamase-inhibiting beta-lactam from *Streptomyces clavuligerus*. *Antimicrob Agents Chemother* 11(5):852–857
- Reddy T, Thomas AD, Stamatis D, Bertsch J, Isbandi M, Jansson J, Mallajosyula J, Pagani I, Lobos EA, Kyrpides NC (2014) The Genomes OnLine Database (GOLD) v. 5: a metadata management system based on a four level (meta) genome project classification. *Nucleic acids Res* 43:D1099–D1106
- Ryu Y-G, Butler MJ, Chater KF, Lee KJ (2006) Engineering of primary carbohydrate metabolism for increased production of actinorhodin in *Streptomyces coelicolor*. *Appl Environ Microbiol* 72(11):7132–7139
- Santos SN, Gacesa R, Taketani RG, Long PF, Melo IS (2015) Genome sequence of *Streptomyces caatingaensis* CMAA 1322, a new abiotic stress-tolerant actinomycete isolated from dried lake bed sediment in the Brazilian Caatinga biome. *Genome Announc* 3(5):e01020–e01015
- Scherlach K, Hertweck C (2009) Triggering cryptic natural product biosynthesis in microorganisms. *Org Biomol Chem* 7(9):1753–1760
- Schröder J, Tauch A (2013) The transcriptional regulatory network of corynebacterium glutamicum. In: *Corynebacterium glutamicum*. Springer, Berlin, pp 239–261
- Schwientek P, Szczepanowski R, Rückert C, Kalinowski J, Klein A, Selber K, Wehmeier UF, Stoye J, Pühler A (2012) The complete genome sequence of the acarbose producer *Actinoplanes* sp. SE50/110. *BMC Genomics* 13(1):1
- Song L, Barona-Gomez F, Corre C, Xiang L, Udwaray DW, Austin MB, Noel JP, Moore BS, Challis GL (2006) Type III polyketide synthase  $\beta$ -ketoacyl-ACP starter unit and ethylmalonyl-CoA extender unit selectivity discovered by *Streptomyces coelicolor* genome mining. *J Am Chem Soc* 128(46):14754–14755
- Starcevic A, Zucko J, Simunkovic J, Long PF, Cullum J, Hranueli D (2008) ClustScan: an integrated program package for the semi-automatic annotation of modular biosynthetic gene clusters and in silico prediction of novel chemical structures. *Nucleic Acids Res* 36(21):6882–6892
- Stephanopoulos G (1999) Metabolic fluxes and metabolic engineering. *Metab Eng* 1(1):1–11
- Tang Z, Xiao C, Zhuang Y, Chu J, Zhang S, Herron PR, Hunter IS, Guo M (2011) Improved oxytetracycline production in *Streptomyces rimosus* M4018 by metabolic engineering of the G6PDH gene in the pentose phosphate pathway. *Enzym Microb Technol* 49(1):17–24
- Tethmol M, Rapoport M, Rapoport T (1984) Network rigidity and metabolic engineering in metabolite overproduction. *Biol Chem* 259:9646
- Tian J, Chen H, Guo Z, Liu N, Li J, Huang Y, Xiang W, Chen Y (2016) Discovery of pentangular polyphenols hexaricins A–C from marine *Streptosporangium* sp. CGMCC 4.7309 by genome mining. *Appl Microbiol Biotechnol* 100(9):4189–4199
- Tiwari K, Gupta RK (2012) Rare actinomycetes: a potential storehouse for novel antibiotics. *Crit Rev Biotechnol* 32(2):108–132

- Udvary DW, Zeigler L, Asolkar RN, Singan V, Lapidus A, Fenical W, Jensen PR, Moore BS (2007) Genome sequencing reveals complex secondary metabolome in the marine actinomycete *Salinispora tropica*. *Proc Natl Acad Sci* 104(25):10376–10381
- Vallino JJ, Stephanopoulos G (1993) Metabolic flux distributions in *Corynebacterium glutamicum* during growth and lysine overproduction. *Biotechnol Bioeng* 41(6):633–646
- Wang Y, Cui T, Zhang C, Yang M, Huang Y, Li W, Zhang L, Gao C, He Y, Li Y (2010) Global protein–protein interaction network in the human pathogen *Mycobacterium tuberculosis* H37Rv. *J Proteome Res* 9(12):6665–6677
- Weber T, Blin K, Duddela S, Krug D, Kim HU, Brucoleri R, Lee SY, Fischbach MA, Müller R, Wohlleben W (2015) antiSMASH 3.0—a comprehensive resource for the genome mining of biosynthetic gene clusters. *Nucleic Acids Res* 43(W1):W237–W243
- Woolston BM, Edgar S, Stephanopoulos G (2013) Metabolic engineering: past and future. *Annu Rev Chem Biomol Eng* 4:259–288
- Xu L, Huang H, Wei W, Zhong Y, Tang B, Yuan H, Zhu L, Huang W, Ge M, Yang S (2014) Complete genome sequence and comparative genomic analyses of the vancomycin-producing *Amycolatopsis orientalis*. *BMC Genomics* 15(1):1
- Yamamura H, Ashizawa H, Hamada M, Hosoyama A, Komaki H, Otoguro M, Tamura T, Hayashi Y, Nakagawa Y, Ohtsuki T (2014) *Streptomyces hokutonensis* sp. nov., a novel actinomycete isolated from the strawberry root rhizosphere. *J Antibiot* 67(6):465–470
- Zabala D, Braña AF, Flórez AB, Salas JA, Méndez C (2013) Engineering precursor metabolite pools for increasing production of antitumor mithramycins in *Streptomyces argillaceus*. *Metab Eng* 20:187–197
- Zerikly M, Challis GL (2009) Strategies for the discovery of new natural products by genome mining. *ChemBioChem* 10(4):625–633
- Zhu D, Seo M-J, Ikeda H, Cane DE (2011) Genome mining in *Streptomyces*. Discovery of an unprecedented P450-catalyzed oxidative rearrangement that is the final step in the biosynthesis of pentalenolactone. *J Am Chem Soc* 133(7):2128–2131
- Zotchev SB (2012) Marine actinomycetes as an emerging resource for the drug development pipelines. *J Biotechnol* 158(4):168–175