

STRATEGIES FOR THE REVISION OF BAKE FURNACES

F. KellerAluminium & Chemie Rotterdam B.V.
NL - 3197 KJ BOTLEK - RotterdamSUMMARY

A large number of carbon plants, which produce anodes for the electrolytic production of aluminium are today more than 15 years old. The result is that some of the equipment has reached the end of its service life.

At the bake furnace the service life can be prolonged with partial repairs. With increasing furnace life, it becomes more and more difficult to find a correct connection between old and new furnace elements both as regards tightness and as regards possibility for thermal expansion. By-pass air penetration leads to a drop in efficiency. Uncontrollable forces lead to a slow self-destruction of the furnace.

A furnace modernization is described, where a total revision of the refractory part was realized with a production loss of only 4 months. The latest know-how regarding furnace construction was taken into account in this revision. At the same time the capacity was increased by 45%. Furnaces revised in this way allow an economic production of anodes of high quality.

INTRODUCTION

During the sixties the aluminium market was characterized by high growth percentages. To meet the demand, many new electrolysis and anode plants were built. After 15 to 20 years of service, several parts of the installation are near the end of their service life. In anode plants, about 70% of the capital is invested in the bake furnaces. The bake furnaces are also the elements which determine the production capacity of the anode plant. For all anode plants with ring-type furnaces, the maximum possible production can be determined as follows:

Production per year (tons):

8760 x number of fires x contents of sections (t)

 cycle time (hours)

Upholding an optimum anode quality becomes more difficult when a furnace gets older. If a deteriorating anode quality leads to a higher specific consumption, it causes an extra demand that can only be satisfied, according to the above formula, by a reduction of the cycle time.

If we try to keep up the bake temperature as before, this leads to overloading, causing a deterioration of the furnace even sooner. If because of this, the quality of the anodes decreases again, the result will be an even higher demand. In anode factories without sufficient spare capacity, this can lead to serious bottlenecks in the production.

In this lecture we are trying to show strategies to break this vicious circle. The lecture describes open ring-type bake furnaces as shown in figures 1 and 2. All essential conclusions apply more or less to hooded type furnaces as well.

State of the art 1965

During the sixties most of the anodes had sizes of 0.5 x 0.5 x 0.5 m to 1.0 x 0.5 x 0.5 m maximum (length x height x width). To bake these - according to today's standards - small anodes, sections with pit sizes of about 3 x 3 x 0.6 m could be used. Cranes with a capacity of 1 to 2 tons were sufficient. A suction capacity of 10 to 15 t/hour to handle filling material was considered most economic according to the labour costs and pneumatic transport techniques at that time. The design of the flues was rather empiric. The handling of the fuel quantity and draft to keep up the prescribed temperature/time curve was done manually.

The operation of this kind of furnace can be characterized as follows: at an average temperature of about 1050°C (measured in the filling material) differences in temperature of about 250° appeared between the hottest and the coolest part of the pit. A flue life of 40 to 60 fire cycles is typical.

It is difficult to determine the optimum maintenance and revision strategy for bake furnaces. The different parts of a furnace, such as flues, headwalls, sidewall and bottom insulation, cross-overs as well as the concrete shell all have different life expectancies. However, together they form the "bake furnace" system and therefore can only be repaired independently to a limited extent. Major repairs, i.e. reconstruction of a bake furnace, can only be executed with a considerable loss of production. Specific information to work out a cost-effectiveness account is hardly available. In spite of all the disadvantages, old furnaces are kept in operation until they show so many structural damages that production can no longer be ensured. It may then be necessary to build a completely new furnace in a



figure 1: Open ring-type bake furnace

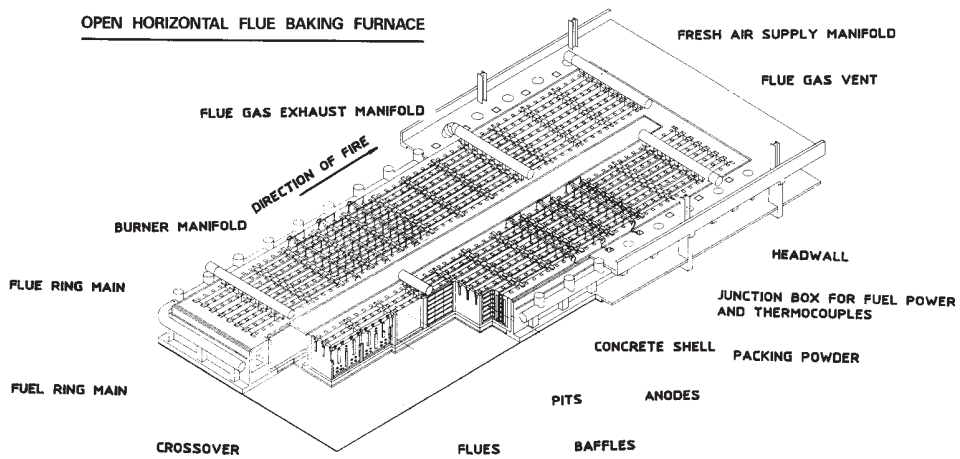

figure 2: Open ring-type bake furnace
(schematic diagram)

completely new building at short notice.

State of the art 1985

Modern electrolysis require anode sizes of about 1.5 x 1.0 x 0.5 m (length x width x height). The costs of energy, personnel and raw materials have grown more during the past 20 years than the price of aluminium. When the anode share of the production costs of aluminium is growing, the production of cheap, high quality anodes becomes more and more important. The baking process, the most expensive part of the production of anodes, therefore, needs careful consideration. That the signs of the times have been understood, can be seen from the many publications during the past few years regarding the dimensions of bake furnaces, the calculations of bake furnaces and the process controlled operation of bake furnaces. Some of these publications are mentioned in the references (1 - 5)

The sizes of the pits of modern bake furnaces are about 5 x 5 x 0.8 m (length, height, width). Cranes usually have a capacity of 6 or more tons. Modern pneumatic installations for filling material have a capacity of 40 to 50 t/hour. The use of a process control system enables a fully automatic operation of the bake furnaces. The process control system together with the optimization of the flow pattern in the flues leads to an even distribution of the temperature. At an average temperature of 1100°C, only differences in temperature of about 100° occur, while the surface has almost been doubled. Figure 3 shows the temperature distribution in a pit with a length and a height of 3.5 m, where the flow pattern has not yet been optimized, and figure 4 shows a process-controlled pit with a length and a height of approx. 5 m, that has been optimized.

In spite of the average higher temperatures, about 100 fire cycles can be reached with the right construction, the proper materials and a good temperature control due to the process-controlled operation of the furnaces. The specific energy consumption of modern bake furnaces is about 30 to 40% lower than that of old furnaces.

Strategies for revision of bake furnaces

Anode factories with old bake furnaces have a choice of 3 different revision strategies:

1. repairing the refractory material during operation.
2. building a new furnace in a new building.
3. completely revising the furnace in the existing building.

The above possibilities have the following advantages and disadvantages:

1. repairing the refractories on a regular basis during operation:

As long as the concrete shell has not been damaged the furnace can be kept in operation for an almost unlimited time by repairing the refractory material on a regular basis. A disadvantage of this method is, however, that it is almost impossible to install new parts, especially flues, in very old and already deformed furnaces in such a way that at the

same time the flues can be connected to the headwalls properly and a sufficient expansion possibility can be guaranteed. In practice air leaks occur, causing extra energy losses. Thermal expansion may lead to deformation of the refractories.

It is almost impossible to realize significant changes, e.g. new sizes of pits, with this type of maintenance. When the concrete walls have been damaged, it may be necessary to take the furnace out of operation, leading to supply problems.

2. building a new furnace in a new building:

Building a new furnace in its own new building enables us to take all technical developments regarding the building of furnaces and anode handling into consideration, without a production stop. The extra costs and the logistical disadvantages, however, are considerable. In general, every new place for a furnace building is less suitable from a logistics point of view.

3. completely revising the furnace in the existing building.

This possibility has the advantage that in the existing building new technologies can be taken into consideration. Parts of the installation such as the flue gas cleaning system, the furnace walls, the foundation and the building itself can still be used. However, the disadvantage is that during the revision, production is not possible. By careful planning and preparation it is possible to reduce the production break to 3.5 to 4 months, even when we are taking advantage of the revision to increase the production capacity.

The bar chart of this type of revision is shown in figure 5. It should be possible to cover the anode supply on the free market during this short revision time.

In the next paragraphs a revision of this kind will be described. Furthermore the actions to increase the lifetime of a bake furnace are indicated. This information will enable the reader to decide about the best possible strategy for revision regarding his own situation.

The Aluchemie anode factory in Rotterdam (The Netherlands) has 6 open ring-type furnaces. Originally the total production capacity amounted to about 230,000 t/year. Anodes are being produced for customers in Europe and overseas. Deliveries are based on longterm contracts as well as single orders. A growing demand forced us to increase the production capacity. The demand for longer, wider and higher anodes has made an adjustment of the flue sizes necessary. In 3 of our bake furnaces, a complete revision has been carried out. Figure 6 shows a furnace during revision. The overhaul has been very significant: the number of sections as well as the number of pits per section has been changed. To increase the capacity, the height of the furnace has been extended by 1 meter; the complete furnace equipment has been adjusted to the new situation and the cranes have been provided with new crane trolleys. As a result of these revisions, the capacity of each furnace has been increased from 38,000 t/year to approx. 55,000 t/year. The first of the revised furnaces has already gone through 50 fire cycles, and the refractories still look like new. We expect to be able to use this furnace for an average of at least 100 fire cycles of the first generation

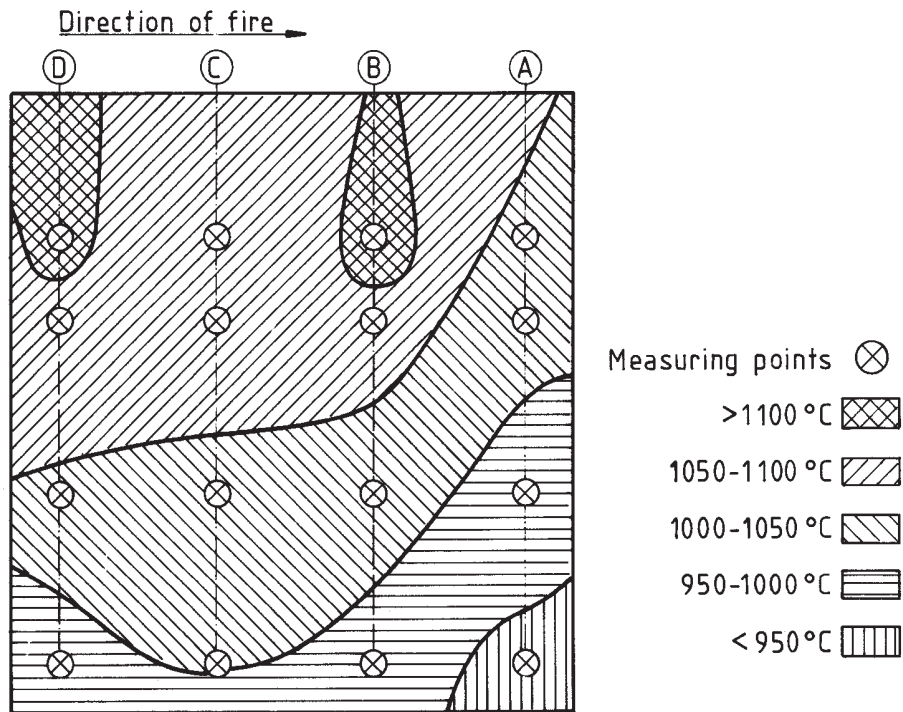

figure 3: Temperature distribution according to the "State of the art 1965"

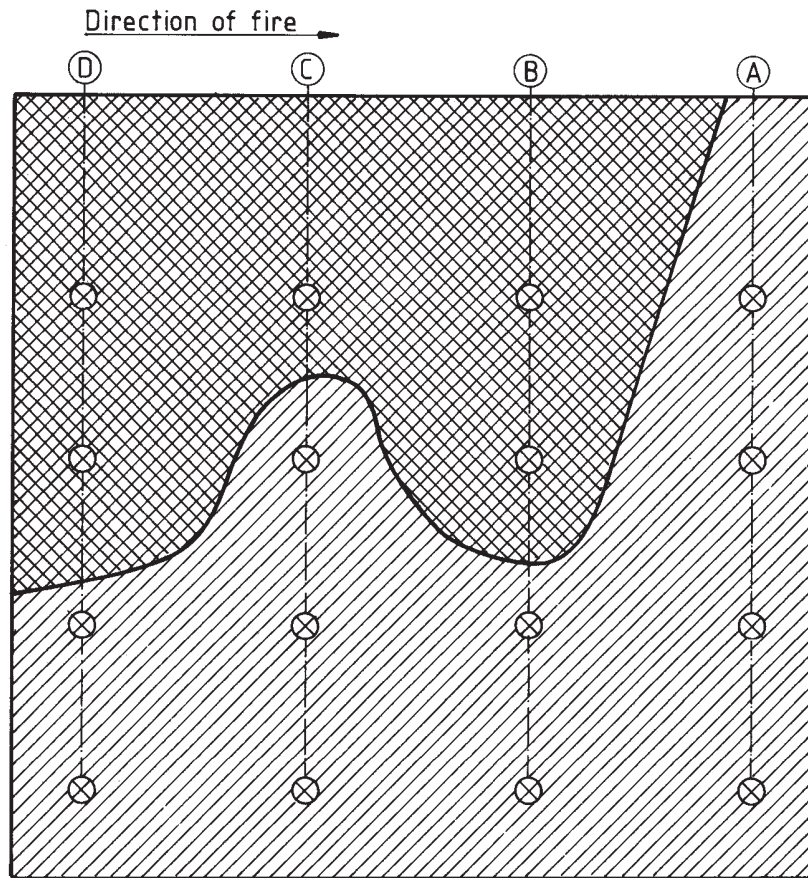

figure 4: Temperature distribution according to the "State of the art 1985"
(same scale as figure 3)

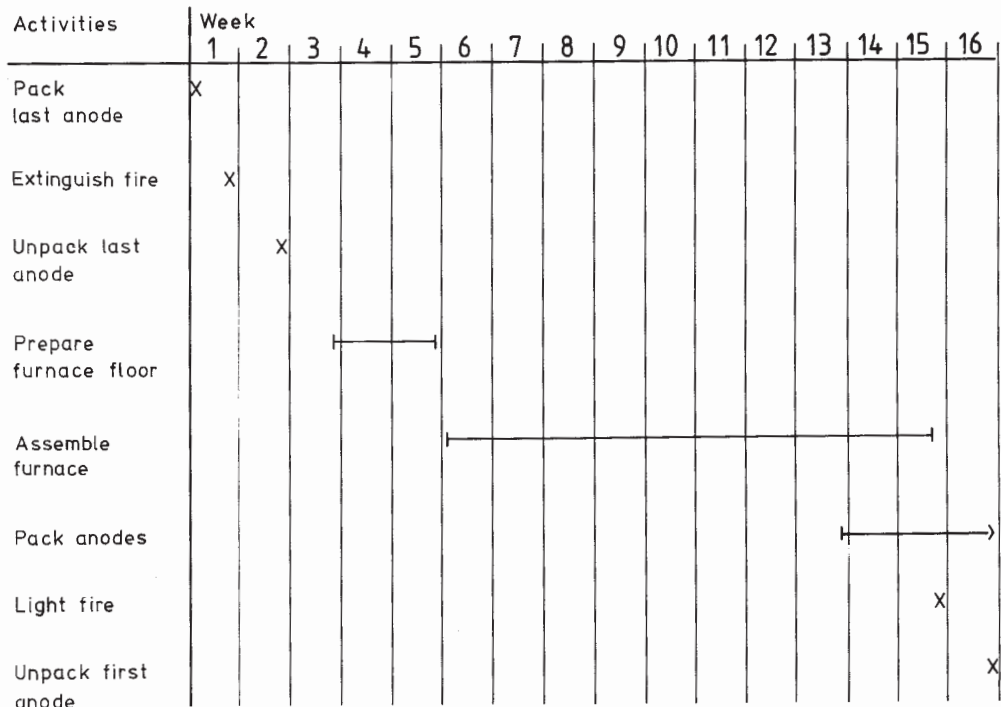

figure 5: Bar Chart Bake Furnace revision

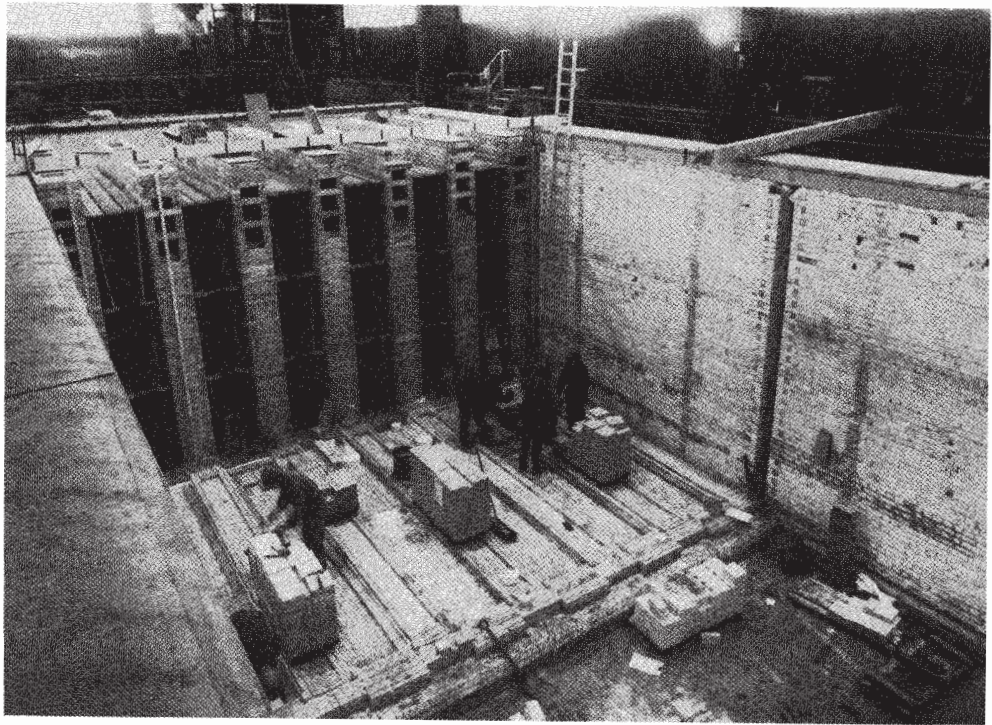

figure 6: Bake Furnace during revision

and at least 80 fire cycles of the second and third generations. Figure 7 shows a flue according to the 1965 technology after 50 fire cycles. To continue operation with such a flue is no longer possible. Figure 8 shows the flue of a revised furnace after 50 fire cycles.

To realize the objectives:

- production increase
- short revision time
- a long life expectancy of the revised furnaces,

the following points have to be considered:

1. Production increase:

- When the number of flues and the cycle time cannot be changed, an increase of the production is only possible by increasing the volume of the pits. Measurements carried out on the furnace building for many years had shown that increasing the height of the furnace by 1 meter was acceptable.

- Measurements showed that pits up to about 5 m height can be used without unacceptable deformation of the bottom layers of the anodes. Higher pits show, depending on the recipe, eventually unacceptable deformation of the bottom layers of the anodes.

- An increase in production consequently means an increase in the capacity of the cranes. After verification of the building statics according to today's sophisticated methods, it turned out that the safety tolerances of the constructions were such that only the cranes had to be reinforced slightly. After this modification, it was possible to replace the original crane with a weight of 55 t by a high capacity crane of 77 t weight.

2. Short revision time:

- The secret of the short revision time is based on very careful preparation. In the course of one year a detailed network planning was carried out. It turned out to be of the utmost importance that everybody concerned participated in this planning. As a lot of work had to be done at the same time in a small place, security aspects also had to be tested. It had to be avoided, for example, that work had to be done on top of each other on different levels without protection. Of favorable influence was that, thanks to the available building, we were not dependent on the weather conditions. Work could continue even during rain and cold.

- As the refractory material had to be brought into the furnace at a certain speed, special steps had to be taken. A separate crane was installed for instance, to ensure the supply of refractory material.

3. Measurements to reach a higher life expectancy:

- The economics of such a major overhaul are greatly influenced by whether the revised furnace has a higher life expectancy and lower maintenance costs. In this connection the following points are important:

- Construction of the furnace: of the utmost importance is for example the design of the expansion joints as well as the best possible sealing between the sidewall insulation and the concrete tub to prevent the filling material from leaking in between. This kind of constructive mistake has an immediate influence on the life of the furnace.

- Construction supervision: as a result of insufficient supervision as far as construction according to the drawing is concerned, an accurate operation with good results may not be possible. Discrepancies during construction may cause structural damages, even leading to destruction of the concrete shell.

- Quality of refractory material: increasing the size of the pits in general justifies the use of a better (and consequently more expensive) quality of refractories.

- Process-controlled operation: only by process controlled operation can the required temperature be maintained without too many fluctuations. In furnaces operated manually, it often happens that the maximum temperature of the refractories is exceeded, reducing the lifetime of the flues.

- Sufficient layers of filling material between the anodes and the pit wall: especially in times of high energy prices furnaces were built with extremely thin layers of filling material between the anodes and the pit walls. The advantage is that the dead volume which has to be heated is reduced. The disadvantage is that the slightest deformation of the flues makes it impossible to pack the anodes. The costs of an early replacement of the flues are generally higher than the savings on energy by reducing the dead volume.

- Preventive maintenance: in general maintenance work is done when further operation of the flue or headwall concerned is no longer possible. A system of preventive maintenance, where small repairs are executed based on regular inspections, considerably extends the service life of the refractories.

It would be exceeding the scope of this report to describe all relevant points in detail. The elements previously described show the basic aspects to be considered in every revision and operation. At Aluchemie we were lucky to know we had to meet long-term additional requirements, and our furnace buildings allowed a significant increase of the production capacity. As a result of extensive full scale tests, the result of the planned revisions could be predicted with a high probability. To facilitate a decision, figure 9 shows the furnace characteristics according to the technology of 1965 and 1985 respectively, i.e. before and after the general revision. The figures will enable others, operating bake furnaces, to interpret their furnace operation and to estimate the advantages to be gained by a general revision.

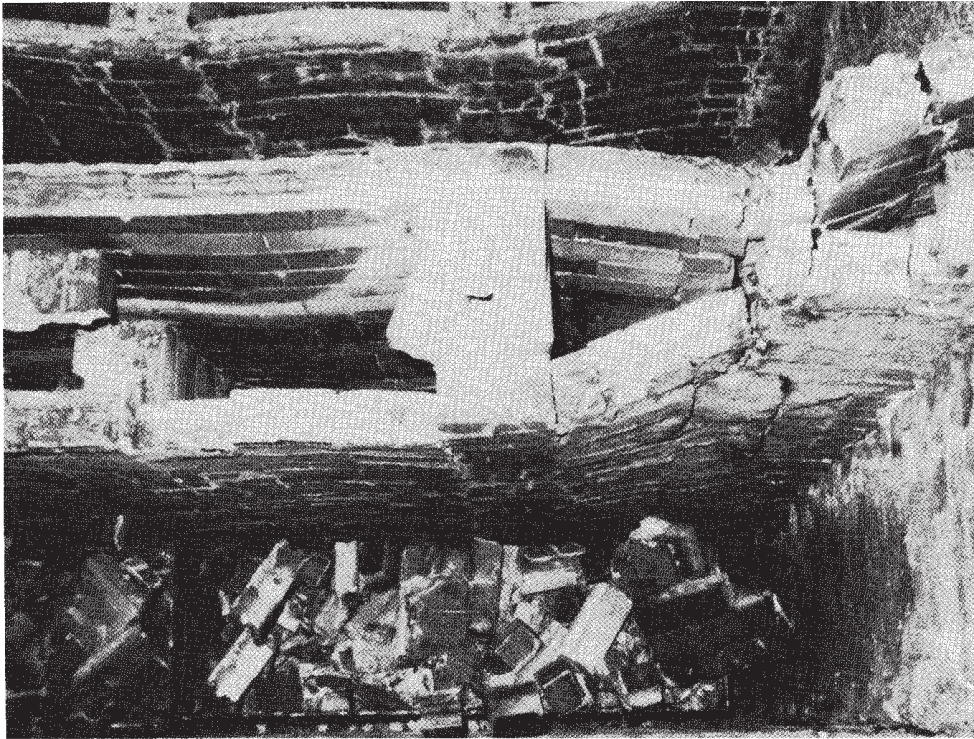

figure 7: Flue according to the "state of the art 1965"
after 50 fire cycles

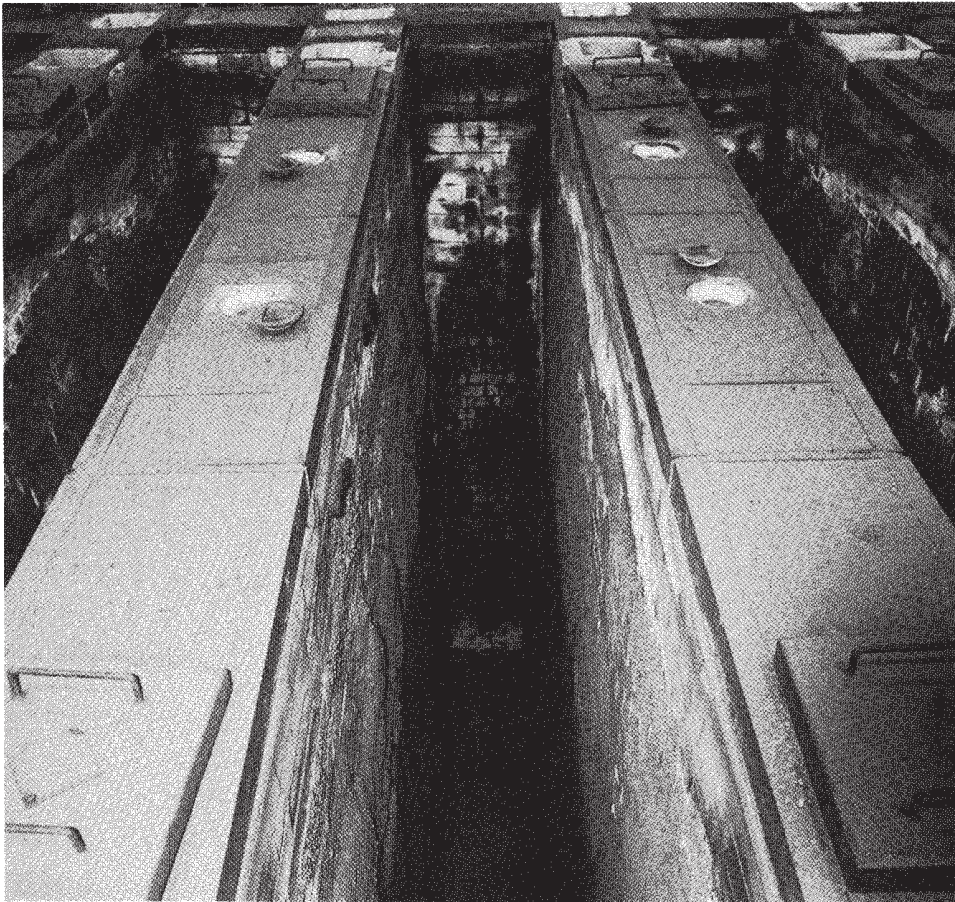

figure 8: Flue according to the "state of the art 1985"
after 50 fire cycles

		Model 1965	Model 1985
pit size (typical)	height	± 3700 mm	5000 mm
	width	600 mm	750 mm
	length	3500 mm	5000 mm
crane capacity	t	2	6
suction capacity	t/h	13	40
energy consumption (excl. energy input through binder & filling material)	GJ/t	4.0	2.8
filling material consumption	kg/t	18	12
manhours	h/t	0.22	0.16
flue life	fire cycle	50	100

figure 9: Typical data of bake furnaces

Conclusions

Bake furnaces, built according to the technology of the sixties no longer fulfil the present requirements regarding efficiency, maintenance and energy consumption. These furnaces often do not allow the production of the anode sizes required today by the electrolysis. Every major overhaul requires high capital investments. Revision times of over a year are not unusual. When a new building has to be erected to prevent delivery problems, the capital investments are even higher. As described and as executed in practice, it is possible to realize a complete revision with a production break of only 4 months. For such a period it should be possible to cover the demand for anodes on the free market.

Of course every single project has to be evaluated by its own border conditions, but in general it is true that much better results can be achieved with old furnaces by using all available modern appliances than was considered possible until recently.

The author hopes to have given some good hints to everybody responsible for the operation and modernization of bake furnaces.

Acknowledgements

The author wishes to thank Messrs. R. Engelsman, G.M. Peereboom, J. Middelburg and W. Venus of Aluchemie, as well as Mr. S. Oderbolz of Alusuisse for their contributions to this lecture and Messrs. Dr. W. Schmidt-Hatting of Alusuisse and W. Fischer of R + D Carbon for their critical review of the manuscript.

References

1. B.J. Racunas, L.L. Young and W.L. Proctor
"Energy Savings in Alcoa Carbon Baking Furnaces"
Aluminium Assoc. Aluminium Industry Energy Conservation Workshop VI (Proc. Conf.), Washington D.C., 9 - 10 Nov. 1981, 129 - 134
2. J.G. Peacey, J. Auton and J. Kaiser
"Reduced Fuel Consumption in Noranda Open-Pit Anode Baking Furnaces"
Light Metals (Atlanta) 1983, 777 - 789
3. S. Oderbolz and O. Mühlemann
"Recording and Interpreting Temperature Distribution in Open Bake Furnaces"
Light Metals (New York) 1978, 315 - 323
4. F. Keller and J.H.M. Disselhorst
"Modern Anode Bake Furnace Developments"
Light Metals (Chicago) 1981, 611 - 621
5. C.M. Benton, F.D. Arnold and H.M. Charlton
"Improvements in Carbon Baking Technology"
Light Metals (Dallas) 1982, 753 - 763