

Modelling & Simulation Architecture Supporting NATO Counter Unmanned Autonomous System Concept Development

Marco Biagini and Fabio Corona^(✉)

NATO Modelling & Simulation Centre of Excellence, Rome, Italy
{mscoe.cd01,mscoe.cd04}@smd.difesa.it

Abstract. The North Atlantic Treaty Organization (NATO) is dealing with possible future threats, which can be envisioned for the operational scenarios in the next twenty years. Allied Command for Transformation (ACT) is in charge to conduct Concept Development & Experimentation (CD&E) cycle for NATO, and a project named Counter Unmanned Autonomous Systems – (C)UAXS was initiated with the aim to deliver to the NATO Military Authorities a concept that provides taxonomy matrix, threats analysis and future capability implementation recommendations for countermeasures against UAXS in all operational domains, such as air, land, sea and cyberspace.

The NATO Modelling & Simulation Centre of Excellence (M&S CoE) received a Request For Support from ACT to collaborate with the CUAXS concept development process. The M&S CoE has previously started an initiatives regarding UAXS systems called Simulated Interactive Robotics Initiative (SIRI). In addition collaborating with several Science and Technology Organization panels working groups, focusing its efforts on interoperability between simulation environment and Command and Control (C2) systems, languages and data model (i.e., National Information Exchange Model). In this framework, the M&S CoE developed an M&S architectural model, exploiting also the Modelling & Simulation as a Service (MSaaS) paradigm, suitable to provide an initial idea of possible tools could be adopted and customized to support the CUAXS project, as in the Concept Development Assessment Game (CDAG) execution, through the verification and validation of Multi-domains UAXS and their countermeasures.

Keywords: Counter autonomous systems · SIRI · NIEM · MSaaS

1 Introduction

The continuous evolution of unmanned systems with autonomous or semi-autonomous functionalities, in civilian and military fields (dual use), urged the North Atlantic Treaty Organization (NATO) to deal with possible future threats, which can be envisioned for the operational scenarios in the next twenty years.

The Allied Command for Transformation (ACT) is in charge to conduct Concept Development & Experimentation (CD&E) cycle for NATO. The project named Counter Unmanned Autonomous Systems – (C)UAXS was initiated with the aim to

deliver to the NATO Military Authorities an operational concept. Furthermore providing taxonomy matrix, threats analysis and future capability implementation recommendations for countermeasures against UAxS in all operational domains, such as air, land, sea and cyberspace.

The NATO Modelling & Simulation Centre of Excellence (M&S CoE) received a Request For Support from ACT to collaborate with this concept development process. Therefore the Centre hosted and participated in the 3rd CUAxS project workshop. Moreover, the M&S CoE worked on robotics with initiatives like Simulated Interactive Robotics Initiative (SIRI), in collaboration with the US Joint Staff J6 Division. This initiative is focused on the interoperability between Multi-robots Systems and Command and Control (C2) systems using National Information Exchange Model (NIEM) Data Model. Regarding this particular interoperability issue, the M&S CoE is participating to the 145 working group of the NATO Modelling and Simulation Group, a panel of the Science and Technology Organization (STO), contributing to the development and standardization of the C2SIM language extension for autonomous systems.

This paper will outline the main aspects of the ACT CUAxS project, it will briefly illustrate the initiatives of the M&S CoE in the robotic field and its interoperability issues. In addition introducing the development of a M&S architecture aimed to support the CD&E activities related to the CUAxS project. Results of this approach will be illustrated as example of experimentation performed using the M&S architecture envisioned.

2 Counter Autonomous Systems (C)UxAxS Project

The CUAxS is a NATO ACT led CD&E project [1] whose aim is to deliver a capstone concept to define the requirements for NATO capability development addressing possible countermeasures against unmanned autonomous systems in the four dimensions (Air, Ground, Sea and C3IS - Command, Control, Communication & Information Systems) in whatever mission (armed or unarmed, combat or reconnaissance, etc.) and the protection of own UAxS.

The need for such countermeasures was born from a military perspective regarding UAxS and their increasing opportunities to be used in joint operations. In addition the level of autonomy of these systems will evolve quickly together with the technology. UAxS have the potential to be used across the whole spectrum of operational functions in low or high intensity conflicts, and by state and non-state actors in a defensive or offensive way.

The implementation of this concept is expected to contribute to the improvement of the overall situational awareness and defence capability. Moreover integrating the existing capabilities like counter-air, anti-surface and anti-submarine and ground defence. Therefore the project purposes are: to update the situational awareness about UAxS in the four dimensions, defining clearly the understanding of “autonomy” and the “level of human interaction” aspect; to identify the various threats to better determine the countermeasures and provide a better assessment about their implementation; to address a future possible CUAxS capability development according to the

full DOTMLPFI spectrum (Doctrine, Organization, Training, Materiel, Leadership, Personnel, Facilities and Interoperability).

These goals are expected to be achieved through the following actions:

- Providing a commonly agreed definition of autonomous systems;
- Providing a stratification matrix based on criteria allowing to define the level of autonomy of a system;
- Determining the threats that UAxS may represent;
- Addressing the impact of the concept across the DOTMLPFI spectrum;
- Providing some suggestions to facilitate the legal/ethical acceptance of the utilization of AxS countermeasures based on the stratification matrix;
- Suggesting a way ahead for a possible future implementation of a CUAxS capability.

The main deliverable of the CUAxS project will be the production of the concept document, moreover an experimentation phase is envisioned, comprehending a Disruptive Technology Assessment Game – DTAG [2] and a Concept Development Assessment Game – CDAG [3].

Both Assessment Games use vignettes within an overall military scenario. DTAG is used to assess the impact of technology on recognizable situations and CDAG is a qualitative analytical method for assessing concepts or conceptual documents. It can be used at various stages in the concept development process. During DTAG potential technologies or focus areas are identified, which are intended for the generation of Idea of Systems (IoS) cards. An IoS card is a card with the description of a potential new



Fig. 1. CDAG four phase process [3]

military system or capability. These IoS cards are then made available to players during a table-top based war game. This game aims to explore how the conduct of operations may change as a result of introduction of new technologies and unmanned autonomous systems. Furthermore investigating about the importance of relevant counter-measures to the IoS cards used in the game.

Likewise, the CDAG is an open table-top analytical war game played by concept developers and end users to assess concepts or elements of concept in an operational context. In the framework of the CUAXS project, CDAG is played to proof the concept using technology cards to simulate the future technologies or scenarios where countermeasures against UAXS are applied. The CDAG is executed in a four phase process as illustrated in Fig. 1.

3 M&S CoE Initiatives on UAXS

Before dealing with the involvement of the M&S CoE in the CUAXS project, a brief overview of the initiatives of the CoE on M&S and Robotics are here illustrated.

3.1 Simulated Interactive Robotics Initiative (SIRI)

Simulated Interactive Robotics Initiative (SIRI) is a cooperative project between the M&S CoE and the US Joint Staff J6, in collaboration with an Italian MoD contractor, the SSI company. It is focused on interoperability issues for integrating a Multi-robot System (MRS) in a Multinational Coalition Scenario [4]. In particular, the initiative is focused on exploring the use of National Information Exchange Model (NIEM) MilOps domain, an eXtensible Markup Language (XML)-based data model for message exchange in an unmanned systems environment.

NIEM seeks to enhance operational effectiveness and promote interoperability by allowing many organizations to access and utilize data and information. NIEM is a standardized format for eXtensible Markup Language (XML)-based data exchanges that serves as a model for information transmission between entities. The model provides a framework with consistent naming and design rules and a standard process for developing data exchanges, and is structured with a core containing common elements and several domains that can inherit elements and modify attributes to accommodate the specific needs of various communities. There are 16 existing domains, each managed by a domain steward who provides training, resolves technical issues, keeps the domain harmonized with the NIEM core and recommends new core components and processes. Information Exchange Packages and Documentation (IEPDs) containing XML schemas are stored in repositories at the domain and core levels and made available for future data interface development. IEPDs can be partially or fully reused, simplifying the development process and reducing the time and resources required for implementation [5].

Going into details, the reference operational scenario was called the Cooperative Multi-robot Information Exchange Demonstrator (COMIED), made of a swarm of Unmanned Ground Vehicles (UGVs), both virtual and real, a planning station and a

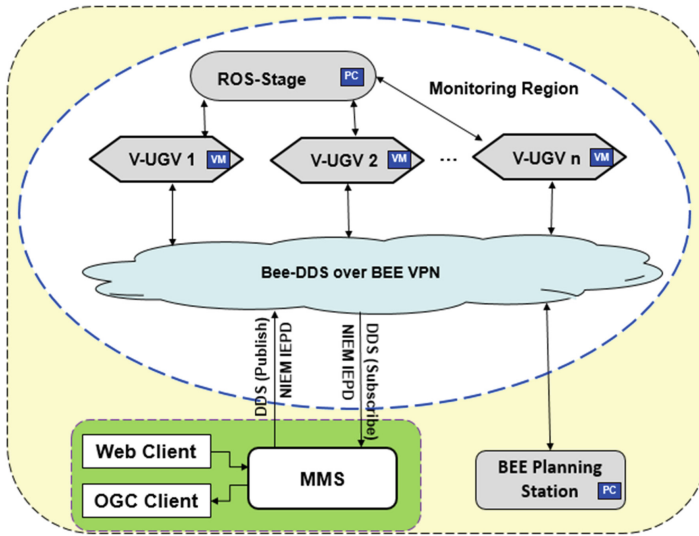

Fig. 2. SIRI overall architecture [4]

Mission Management Station (MMS). The UGVs were capable of coordinating their activities to explore the environment in a safe, efficient and effective way during the detection, identification, classification and neutralization of threats. The V-UGVs were developed based on the ROS/Stage [6] simulation environment. A customized version of the Data Distribution Service Standard (DDS), the BEE-DDS, was developed by the M&S CoE's contractor, to connect the various distributed nodes. Figure 2 shows this architecture.

A demonstration was conducted from April 2014 to April 2015 with a collaborative evaluation and effort between the NATO M&S CoE and the US Joint Staff J6, supported by the Georgia Tech Research Institute in Atlanta and the SSI company in Rome [7]. The Multi-robot System (MRS) was located in Rome (Italy) and was composed by a swarm of 4 networked Virtual UGVs and a real prototype. The MMS, based on the FalconView tool, was remotely connected from US via Virtual Private Network (VPN) over Internet. The event involved exchanging NIEM-conformant XML messaging messages between UGVs and the MMS, as well as sending NIEM-conformant XML messaging command messages from the MMS to the UGVs.

3.2 NATO STO IST 136 - Security Challenges for Multi-domain Autonomous and Unmanned C4ISR Systems

M&S CoE participated to the meeting of the 136 Specialist Team of the Information System Technology (IST), another STO panel [8]. The meeting took place at NATO Center for Maritime Research and Experimentation (CMRE) in La Spezia, Italy, in March 2016. It brought together experts and practitioners from NATO Nations, military agencies, industry and academy. During the event they were presented and

discussed the state-of-the-art developments and security challenges for multi-domain unmanned and autonomous Command, Control, Communications, Computers, Intelligence, Surveillance and Reconnaissance (C4ISR) systems. During the meeting a variety of topics and activities involving emerging models of synchronized operations, unmanned, autonomous and semi-autonomous systems UAxS's, with types of missions and C4ISR functions being performed, were explored.

Such venue had the ambition to combine the vision of the operational communities (ACT and NATO Headquarters), the strategic foresight of NATO bodies (CMRE and NATO Communications and Information Agency – NCIA), the technical insight of STO Panels, such as IST and NATO Modelling and Simulation Group (NMSG). Furthermore in order to start to address the security requirements and challenges regarding multi-domain UAxS's.

3.3 STO CSO NMSG 145 – Operationalization of Standardized C2-Simulation Interoperability

The M&S CoE participates to the NMSG 145 Research Task Group [9]. It has the aim to operationalize the Command and Control – Simulation environments (C2SIM) interoperability standards and technologies. In particular, the group is developing extensions to the unified C2SIM (Mission Scenario Development Language – MSDL/Coalition-Battle Management Language – C-BML) core Data Model for specific functional areas (e.g., Autonomous systems). They publicize also the standards development process and motivate suppliers to develop products, other than educate the community of practice on C2SIM technology. A final goal is to make recommendations for formalizing the C2SIM standard with a STANAG. The M&S CoE part of the subgroup is in charge to develop of the C2SIM extension for UAxS.

4 NATO ACT CUAxS CD&E Workshop

The M&S CoE hosted and participated at the 3rd workshop of the CUAxS project. The workshop goal was to make tangible progress on the concept development of the CUAxS. The outcomes of the experimentation phase of DTAG, which took place in Norfolk, VA (USA) in January 2016, were considered. Regarding the UAxS capability envisioned during the DTAG, were taken into account the functionalities of the UAxS and their “level of autonomy.” In particular, the autonomy concept was defined on the interaction basis with humans, independently from the technology level. Furthermore on the premises of the previous 2013–2014 Multinational Capability Development Campaign (MCDC) cycle [10]. This interaction, based on the operational scenario, comprehends both control and data link. In order to introduce a concise classification, this “level of autonomy” is characterized by a number in the range 0 to 6, from a fully controlled system to a totally independent one.

Another important element developed to support the CUAxS concept is the “Stratification matrix”. This matrix put in relationship the level of autonomy with the type of operations (the NATO Campaign themes) and the operational functional areas,

as defined in the Allied Joint Doctrine [11], or type of unit (i.e., combat, combat support, combat service support). Each row of this matrix refers to an operational scenario and it reports the suitable levels of autonomy depending on the kinds of operational unit, as reported in the columns.

Finally, the countermeasures development process advanced with the definition of the UAxS functionalities, in order to identify the possible vulnerabilities of these systems and, therefore, the countermeasures to exploit these weaknesses. In this framework, M&S CoE proposed to design an architectural concept based on M&S tools suitable to support the CUAxS concept development and experimentation activities and the implementation of these tools to support the Concept Development Assessment Game (CDAG) wargame [3].

5 Modelling & Simulation Architecture Supporting (C)UAXS CD&E Activity

In order to fully support ACT CD&E process, the M&S CoE is developing an M&S architectural model, in collaboration with other NATO and US bodies, industry and academia. The approach followed under the Modelling & Simulation as a Service (MSaaS) paradigm [12], as being developed by the MSG-136 research task group [13], is here exposed. The architectural model is following the recommendation for M&S experimental frameworks for Autonomous Systems [14, 15]. The main goals are the implementation of the following main capabilities:

- Interoperability between Robotic Operating System (ROS)-based UAxS and Standard\National\NATO C2\C4ISR systems, through the message exchange using NIEM Data Model and C2SIM language;
- Synthetic-Based Environment (SBE), implemented with a federation of systems, like Robot Scenario Generator and Animator (R-SGA), Networks and Communications Simulator (Cyberspace Arena), C2 systems and real Robot prototypes.

The SBE concept originates from the implementation and customization of an ongoing National (Italian) Military Research Program (PNRM), the Cyber Security Simulation Environment (CSSE). It arises from the need to study, through the use of advanced simulation systems, problems related to cyber threats facing the communications networks (tactical or infrastructured) of military units may be subjected engaged in.

In details, the architecture of the SBE is designed to integrate a federation of simulators and a real/virtual robotic environment, both interacting with real C2 systems. The simulation federation is based on an HLA Run-Time Infrastructure (RTI) and it is composed by: a Robot Scenario Generator and Animator (RSGA), responsible for the scenario management, including the terrain generation, entity and event interaction, and virtual robot representations in the scenario; a behavior generator for (C)UAXS, responsible for implementing the cooperative behavior of the autonomous systems; a Networks and Communications Simulator (Cyberspace Arena), such as a network simulator with the added capability to be stimulated by pretending cyber-attacks; virtual robots, built on ROS and implemented in virtual machines (VMs); real robots,

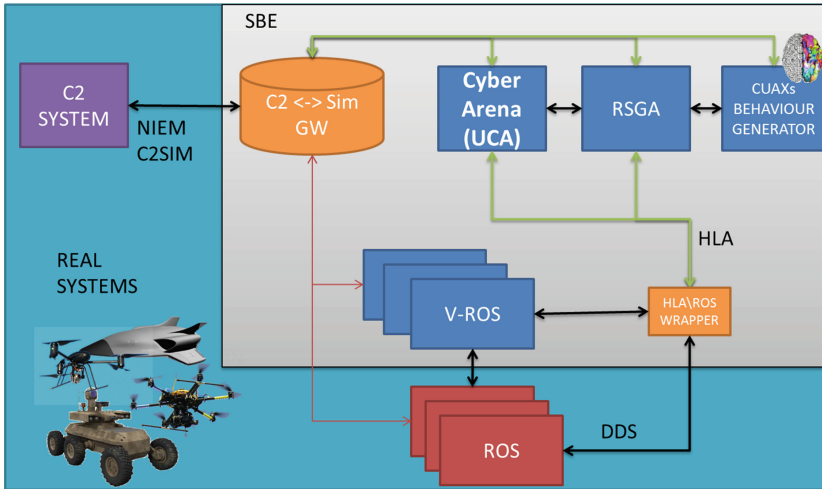

Fig. 3. Conceptual architecture of M&S tools to support the CUAxS project

which can be prototypes or commercial-of-the-shelf (COTS) products; an HLA/ROS wrapper, integrated in the VMs or as a separate component, which allows the federation of the robotic platforms, real or virtual, to the HLA RTI; real C2 systems, for the integration between the real and synthetic worlds; one or more gateways for communication and interoperability between C2 systems and the HLA federation. This environment will be integrated in a cloud infrastructure for providing and consuming M&S services under the MSaaS paradigm, as depicted in Fig. 3.

The acquired expertise on NIEM MilOps and C2Sim through previous experimental initiatives (SIRI) and participation to the MSG-145 will be exploited to use these languages for message exchange between C2 systems and UAxS. The aim is to realize mission control and feedback during a simulation involving UAxS, using standard languages and data models which can be used in the military and civilian worlds. In addition high level languages that are as close as possible to the human natural language in which standard military orders are issued.

This simulation environment is suitable to support the CDAG implementation and some of the execution phases introduced in the Sect. 2. With the effort to maintain the some level of the flexibility offered by the CDAG, the scenarios and the Orders of Battle (ORBATs) will be pre-set, using on-demand services like terrain generation and Computer Force Generated (CFG) service, through a Web interface.

The Concept and Technical Cards could be digitalized or substituted by simulation routines and added to the scenario of the vignette to be played. So, the planning phase of the CDAG can be performed with the simulation aid and the confrontation phase can be anticipated by the planned course of action run on the simulation environment. This will add automation at the CDAG execution, speeding the process and standardized way to record and analyze the results of the planned actions.

6 Conclusions

In conclusion, a M&S architecture is modelled to support the CD&E process in general. This architectural model is suitable to be used to run a gap analysis, performing a high level risk reduction and, finally, to provide an initial idea of possible tools could be adopted and customized to support the CUAXS project. These tools could be implemented to support the Concept Development Assessment Game (CDAG) phase, through the verification and validation of Multi-domains UAXS and their countermeasures. In addition, the tools could be used to verify the conceptual maturity level of autonomy and the stratification matrix (mission threats), outputs from ACT CUAXS workshop.

This study is intended as a contribution to the development of M&S tool to support innovative ideas for future capability implementations and recommendations for UAXS countermeasures.

References

1. NATO ACT CEI CAPDEV: Autonomous Systems Countermeasures (2016). <http://innovationhub-act.org/AxSCountermeasures>. Accessed May 2016
2. NATO STO SAS 082: Disruptive Technology Assessment Game - Evaluation and Validation (2012). <http://www.cso.nato.int/activities.aspx?pg=2&RestrictPanel=6&FMMod=0&OrderBy=0&OrderWay=2>. Accessed May 2016
3. NATO STO SAS 086: Maritime Situational Awareness: Concept Development Assessment Game (CDAG) (2010). <http://www.cso.nato.int/activities.aspx?pg=3&RestrictPanel=6&FMMod=0&OrderBy=0&OrderWay=2>. Accessed May 2016
4. SSI Finmeccanica Company: SIRI Operational Scenario, Taranto (2015)
5. NIEM: National Information Exchange Model (2016). <https://www.niem.gov/Pages/default.aspx>. Accessed May 2016
6. ROS: Robotic Operating System (ROS) Documentation (2016). <http://wiki.ros.org/>. Accessed May 2016
7. Litwiller, S., Weber, M., Klucznik, F.: Improving robotic and autonomous system information interoperability: standardizing data exchange with XML. In: Hodicky, J. (ed.) MESAS 2015. LNCS, vol. 9055, pp. 24–39. Springer, Rome (2015)
8. Byrum, F., Sidoran, J.: IST 136 Roadmap - Security Challenges for Multi-domain Autonomous and Unmanned C4ISR Systems (Draft - unpublished), STO CSO (2016)
9. NATO STO NMSG 145: Operationalization of Standardized C2-Simulation Interoperability. STO CSO - STO activities (2016). <http://www.cso.nato.int/activities.aspx?RestrictPanel=5>. Accessed May 2016
10. MCDC: Policy Guidance - Autonomy in Defence Systems (2014). <http://innovationhub-act.org/sites/default/files/u4/Policy%2520Guidance%2520Autonomy%2520in%2520Defence%2520Systems%2520MCDC%25202013-2014%2520final.pdf>. Accessed May 2016
11. NATO Standardization Agency: Allied Joint Doctrine - AJP 1.0 (D). NATO document, Brussels (2010)
12. Siegfried, R., Van den Berg, T., Cramp, A., Huiskamp, W.: M&S as a service: expectations and challenges. In: Fall Simulation Interoperability Workshop, Orlando, FL, USA, pp. 248–257 (2014)

13. NATO STO MSG 136: Modelling and Simulation as a Service. STO CSO - STO activities (2016). <http://www.cso.nato.int/activities.aspx?RestrictPanel=5>. Accessed May 2016
14. Hodicky, J.: Modelling and simulation in the autonomous systems' domain - current status and way ahead. In: Hodicky, J. (ed.) MESAS 2015. LNCS, vol. 9055, pp. 17–23. Springer, Heidelberg (2015)
15. Hodicky, J.: HLA as an experimental backbone for autonomous system integration into operational field. In: Hodicky, J. (ed.) MESAS 2014. LNCS, vol. 8906, pp. 121–126. Springer, Heidelberg (2014)