

History of Mechanism and Machine Science 31



Francesco Sorge  
Giuseppe Genchi *Editors*

# Essays on the History of Mechanical Engineering

 Springer

# **History of Mechanism and Machine Science**

Volume 31

## **Series editor**

Marco Ceccarelli

LARM: Laboratory of Robotics and Mechatronics

DICeM; University of Cassino and South Latium

Via Di Biasio 43, 03043 Cassino (Fr), Italy

[ceccarelli@unicas.it](mailto:ceccarelli@unicas.it)

## **Aims and Scope of the Series**

This book series aims to establish a well defined forum for Monographs and Proceedings on the History of Mechanism and Machine Science (MMS). The series publishes works that give an overview of the historical developments, from the earliest times up to and including the recent past, of MMS in all its technical aspects.

This technical approach is an essential characteristic of the series. By discussing technical details and formulations and even reformulating those in terms of modern formalisms the possibility is created not only to track the historical technical developments but also to use past experiences in technical teaching and research today. In order to do so, the emphasis must be on technical aspects rather than a purely historical focus, although the latter has its place too.

Furthermore, the series will consider the republication of out-of-print older works with English translation and comments.

The book series is intended to collect technical views on historical developments of the broad field of MMS in a unique frame that can be seen in its totality as an Encyclopaedia of the History of MMS but with the additional purpose of archiving and teaching the History of MMS. Therefore the book series is intended not only for researchers of the History of Engineering but also for professionals and students who are interested in obtaining a clear perspective of the past for their future technical works. The books will be written in general by engineers but not only for engineers.

Prospective authors and editors can contact the series editor, Professor M. Ceccarelli, about future publications within the series at:

LARM: Laboratory of Robotics and Mechatronics  
DICeM; University of Cassino and South Latium  
Via Di Biasio 43, 03043 Cassino (Fr)  
Italy  
email: [ceccarelli@unicas.it](mailto:ceccarelli@unicas.it)

More information about this series at <http://www.springer.com/series/7481>

Francesco Sorge · Giuseppe Genchi  
Editors

# Essays on the History of Mechanical Engineering

 Springer

*Editors*

Francesco Sorce  
Chemical, Management, Informatics  
and Mechanical Engineering  
University of Palermo  
Palermo  
Italy

Giuseppe Genchi  
Chemical, Management, Informatics  
and Mechanical Engineering  
University of Palermo  
Palermo  
Italy

ISSN 1875-3442

ISSN 1875-3426 (electronic)

History of Mechanism and Machine Science

ISBN 978-3-319-22679-8

ISBN 978-3-319-22680-4 (eBook)

DOI 10.1007/978-3-319-22680-4

Library of Congress Control Number: 2015951518

Springer Cham Heidelberg New York Dordrecht London

© Springer International Publishing Switzerland 2016

This work is subject to copyright. All rights are reserved by the Publisher, whether the whole or part of the material is concerned, specifically the rights of translation, reprinting, reuse of illustrations, recitation, broadcasting, reproduction on microfilms or in any other physical way, and transmission or information storage and retrieval, electronic adaptation, computer software, or by similar or dissimilar methodology now known or hereafter developed.

The use of general descriptive names, registered names, trademarks, service marks, etc. in this publication does not imply, even in the absence of a specific statement, that such names are exempt from the relevant protective laws and regulations and therefore free for general use.

The publisher, the authors and the editors are safe to assume that the advice and information in this book are believed to be true and accurate at the date of publication. Neither the publisher nor the authors or the editors give a warranty, express or implied, with respect to the material contained herein or for any errors or omissions that may have been made.

Printed on acid-free paper

Springer International Publishing AG Switzerland is part of Springer Science+Business Media  
([www.springer.com](http://www.springer.com))

# Preface

The twelfth PC Workshop on the History of Mechanism and Machine Science (MMS) was held at the Polytechnic School of the University of Palermo, Italy, in November 21–22, 2013, under the patronage of the IFToMM. It was organized by Profs. Marco Ceccarelli, Francesco Sorce, Marco Cammalleri, and Giuseppe Genchi and was hosted inside the Museum of Engines and Mechanisms of the University of Palermo, whose director and chief manager, F. Sorce and G. Genchi, respectively, are the editors of this book.

All workshops of the IFToMM Permanent Commission for the History of Mechanism and Machine Science are organized as limited-circle meetings with the aim of promoting the presentation of unpublished material and stimulating new interest in various historical developments in the fields of Mechanism and Machine Science. They want to open debates on many aspects associated with the birth and growth of mechanisms and machines from antiquity up to the present day: kinematics, dynamics, design methods, collections of models, teaching aids, historical biographies, individuals, institutions, etc. The first of these workshops was held in Admont, Austria, in 2002, and was followed nearly annually by eleven further meetings with parallel objectives. The focus of the 2013 HMMS Workshop in Palermo was, in particular, on the European History of Mechanism and Machine Science.

The idea of the present book originated after the workshop out of the desire to give a complete and extensive form to the abstracts that were proposed on that occasion. Most of these abstracts were turned into extended papers by the attending authors, collecting the information given in their oral presentations and enriching their work with new data and results from the ensuing historical researches. After acceptance from a review process, the extended papers were then distributed into separated parts of the book, collecting them in accordance with their themes, in which each paper constitutes, in practice, a chapter of the book and each section refers to a particular aspect of the history of mechanisms and machines.

- Part I is dedicated to several eminent scientists of the past, whose individual contributions may be considered as milestones in the history of MMS. In particular, this part offers a deep insight into certain advancements brought to scientific knowledge by renowned scholars such as Lagrange, Borgnis, Reuleaux, Ovazza and Frolov.
- Part II illustrates relevant aspects of the wide industrial development that has so deeply been involved in European civil life during the last two centuries. In particular, very interesting chapters are presented on various types of ancient mill installation in Abruzzo and Tuscany in Central Italy; on the sulfur mining industry of the nineteenth and twentieth centuries in Sicily; on the aviation industry in Romania at the beginning of the twentieth century; on the industrial progress in Southern Italy before the unification of the Kingdom of Italy and in Northern Italy before and after the unification.
- Part III concerns the history of machinery for fixed and moving application, and the history of transport in general. It addresses the pioneering development of technology in the field of motors and transport, and presents, in respective chapters: the collection of the Museum of Engines and Mechanisms of Palermo; the history of an ancient Spanish railway; and the devising of the first airships of the nineteenth century.
- Part IV is dedicated to human creativity in the field of mechanical and scientific devices, starting from ancient times up to the last century. The subjects cover machines built during the Renaissance on the basis of ancient designs of the Roman period; the bellows devices operated by falling water in use in the forges of the Middle Ages and the Renaissance; pendulum clock development through the centuries; the screw pumps conceived in Central Italy by Guido Ubaldo Del Monte at the dawn of the Renaissance; and the progress in the measurement methods for the shaft torsional stress state.
- Part V deals with several ingenious machines dating from the remote and recent past, all designed with the aim of relieving or replacing human manual work or setting in motion very huge structures. Starting from antiquity, very heavy carts are described in detail, together with their construction technique, the so-called Rathams or Thers, which were brought in procession by human and animal traction in ancient India. Moreover, operation of an automaton of the Hellenistic period is analyzed, which moved up and down upon a procession cart and had to be probably actuated by special mechanisms. Lastly, a survey is given on the history of robots in general, including some recent examples that were devised and built at the Polytechnic University of Milan near the end of the last century and are now exhibited in the Museum Leonardo da Vinci in Milan.

As mentioned in the brief description of Part III, the book contains a chapter on the Museum of Engines and Mechanisms of Palermo, in which collections of historical pieces are briefly described with the aid of a number of illustrative figures. The museum belongs to the museum system (Sistema Museale di Ateneo-MUSEIUNIPA) of the University of Palermo, together with the museums of Zoology, Geology, Radiology, the “Specola,” or Astronomic Observatory, and the

Botanical Garden. It was inaugurated in February 2011 and collects more than three-hundred items testifying to the development of the mechanical sciences in the last one hundred and fifty years of history. Its contents cover the fields of automotive and aircraft engines, stationary engines, hydraulic machines, laboratory, and didactic devices. Just to mention a few examples, we recall the following: the FIAT G.59 trainer aircraft of the 1950s, which has been recently restored by the Museum and represents one of the five remaining specimens in the world; the radial steam turbine Ljungstrom of the old electric power plant in Palermo; a rare Siemens Halske IIIa bi-rotary aero-engine, the crankshaft, and crankcase of which counter-rotated with opposite angular speeds. All the pieces were taken from the storerooms of the former Institute of Machines and were revived thanks to a scrupulous work of restoration, accompanied by careful historical research. The Museum is our own pride and the pride of the University of Palermo. Many scientific events have been hosted there, and many others are continuously programmed. Its choice as the venue for the twelfth PC Workshop on the History of Mechanism and Machine Science fit quite well with the themes of the meeting and it is hoped that other similar events will take place there in the future.

To sum up, despite the limited number of contributions, this volume shows a wide-ranging panorama on the historical progress of scientific and technical knowledge, mainly in the European environment. Hopefully, it may give new stimuli to all people involved in the history of Science and Technology.

Finally, the editors wish to express their gratitude to all people who have given their valuable contributions to this editorial project, and in particular, they thank all the authors and co-authors of the chapters for the enthusiasm they have put in preparing their admirable essays. Special thanks are devoted to the editorial staff of Springer for their helpful co-operation. Moreover, the editors owe a warm acknowledgment to their friend, Professor Marco Ceccarelli, for his precious suggestions during the groundwork and preparation of this book and for his assistance during the editorial process.

Palermo  
December 2014

Francesco Sorge  
Giuseppe Genchi



# Contents

## Part I Eminent Scientists of the Past

<b>Lagrange as a Historian of Mechanics</b> . . . . .	3
Agamenon R.E. Oliveira	
<b>Giuseppe Antonio Borgnis and His Handbook of Machine Designs</b> . . . .	15
Marco Ceccarelli	
<b>Tribute to Reuleaux</b> . . . . .	35
Roberto Bragastini	
<b>Elia Ovazza, Professor of TMM in Palermo Around the End of the 19th Century.</b> . . . . .	47
Marco Ceccarelli, Francesco Sorge and Giuseppe Genchi	
<b>Academician K.V. Frolov at Bauman Moscow State Technical University.</b> . . . . .	65
Olga Egorova and Gennady Timofeev	

## Part II History of Industrial Installations

<b>Historical Watermills. Architectural, Mechanical and Hydraulic Heritage</b> . . . . .	81
Mario Centofanti, Stefano Brusaporci and Vittorio Lucchese	
<b>The Mill at the Orbetello Lagoon: Mechanisms and Hydraulic Energy.</b> . . . . .	99
Emanuela Chiavoni	
<b>The Sulphur Mining Industry in Sicily.</b> . . . . .	111
Vincenzo Ferrara	
<b>The History of Aircraft Manufacturing at the Braşov IAR Plant.</b> . . . .	131
Horia Salcă and Dan Săvescu	

<b>Science, Technology and Industry in Southern Italy Before the Unification</b> . . . . .	159
Cesare Rossi and Marco Ceccarelli	
<b>Medium Size Companies of Mechanical Industry in Northern Italy During the Second Half of the 19th Century</b> . . . . .	181
Yibing Fang and Marco Ceccarelli	
<b>Part III History of Machinery and Transport</b>	
<b>The Museum of Engines and Mechanisms. More Than a Century of History of Technology</b> . . . . .	201
Riccardo Monastero and Giuseppe Genchi	
<b>History of the Trains Used on the Spanish Railway Line Madrid–Almorox</b> . . . . .	227
Daniel Fernández Caballero, Víctor Rodríguez de la Cruz, Julián Martín Jarillo and Manuel Esperón Miguez	
<b>Airship—The American Dream by Quirico Filopanti, 1851</b> . . . . .	241
Pier Gabriele Molari	
<b>Part IV Human Inventiveness for Mechanical and Scientific Devices</b>	
<b>Archimedes’ Screw in the Four Books “De Cochlea” by Guido Ubaldo del Monte [Santa Maria]—Venice—1615: The Engineering and the Language</b> . . . . .	255
Elena Magnini and Pier Gabriele Molari	
<b>On the Birth and Growth of Pendulum Clocks in the Early Modern Era</b> . . . . .	273
Francesco Sorge, Marco Cammalleri and Giuseppe Genchi	
<b>Machine Designs and Drawings in Renaissance Editions of de Architectura by Marcus Vitruvius Pollio</b> . . . . .	291
Michela Cigola and Marco Ceccarelli	
<b>Trompes or Water Bellows. A Way of Producing Wind Through the Fall of Water</b> . . . . .	309
Umberto Meneghetti	
<b>Determination of Torsional Stresses in Shafts: From Physical Analogies to Mathematical Models</b> . . . . .	327
Augusto Ajovalasit, Vincenzo Nigrelli, Giuseppe Pitarresi and Gabriele Virzì Mariotti	

**Part V Robots and Human-Driven Automata**

**The Automaton Nysa: Mechanism Design in Alexandria  
in the 3rd Century BC . . . . .** 347  
Teun Koetsier and Hanfried Kerle

**Hindu Temple Carts—Rathams . . . . .** 367  
J.S. Rao, Babaji Raja Bhonsle and Bigil Kumar

**Robots: An Evolving Species . . . . .** 389  
Alberto Rovetta and Vincenzo Iannone

**Part I**  
**Eminent Scientists of the Past**

# Lagrange as a Historian of Mechanics

Agamenon R.E. Oliveira

**Abstract** In the first and second parts of his masterpiece, *Analytical Mechanics*, dedicated to static and dynamics, respectively, Lagrange (1736–1813) describes in detail the development of both branches of mechanics from a historical point of view. In this paper, Lagrange’s important contribution (Lagrange 1989) to the history of mechanics is presented and discussed in tribute to the bicentennial year of his death.

## 1 Introduction

Lagrange was one of the founders of variational calculus, through which he derived the Euler-Lagrange equations. He also developed the method of Lagrange multipliers, which is a manner of finding local maxima and minima of a function subjected to constraints. He developed the method for solving differential equations known as the parameter variation method. In addition, he applied differential calculus to the theory of probabilities and did notable work in obtaining the solution of algebraic equations. Furthermore, in calculus, Lagrange introduced a new approach for the interpolation of the Taylor (1685–1731) series. His famous treatise known as the *Theory of Analytical Functions* contains the path that leads to the foundation of group theory, anticipating the work of Evariste Galois (1811–1832).

In mechanics, Lagrange studied specific problems, such as the three-body problem related to the motion of the earth, sun and moon. By means of his *Analytical Mechanics*, he transformed Newtonian mechanics (Newton 1952) into a branch of analysis, Lagrangian mechanics, which was a result of the application of variational calculus to mechanical principles. Through this work, rational

---

A.R.E. Oliveira (✉)

Polytechnic School of Rio de Janeiro, Federal University of Rio de Janeiro,  
Rio de Janeiro, Brazil  
e-mail: agamenon.oliveira@globocom

mechanics was able to fulfill the long-desired Cartesian aim of becoming a branch of pure mathematics.

In relation to problems later called applied mechanics, Lagrange, in the works known as the *Mélanges de Turin*, studied the propagation of sound, making an important contribution to the theory of vibrating strings. He used a discrete mass model to represent string motion consisting of  $n$  masses joined by weightless strings. Then, he solved the system of  $n + 1$  differential equations, when  $n$  tends to infinity, to obtain the same functional solution proposed by Euler (1707–1783). Lagrange also studied the integration of differential equations and made various applications to topics such as fluid mechanics, for which he introduced the Lagrangian function.

Lagrange's *Analytical Mechanics* was published in 1788, crowning a series of works and other important contributions previously developed by d'Alembert (1717–1783) and Euler (1952). This book presents a model of formalized theory with the same meaning that is now understood by modern physicists. The logical unity of this theory is based on the least action principle. However, the two dimensions of formalization and unification are the main characteristics of Lagrange's method.

## 2 Lagrange: A Biographical Note

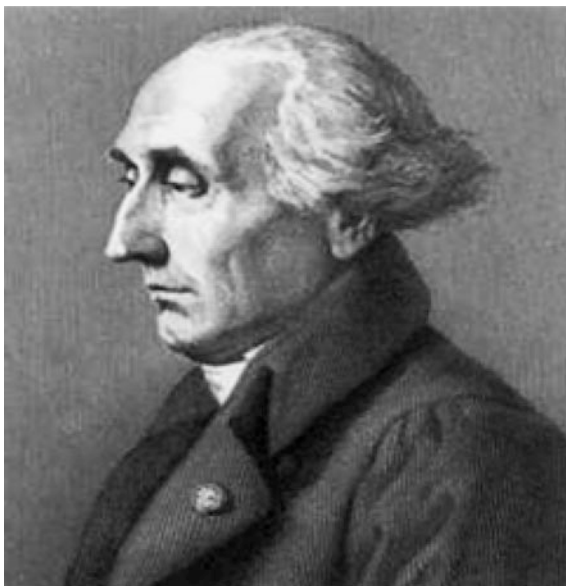
Joseph-Louis Lagrange was born in Turin on January 25, 1736, under the name of Giuseppe Lodovico Lagrangia (Fig. 1). His father, Giuseppe Francesco Lodovico Lagrangia, was Treasurer of the Office of Public Works and Fortifications in Turin. His mother was Teresa Grosso, the only daughter of a medical doctor from Cambiano near Turin. Lagrange was the eldest of their eleven children, but one of only two to live to adulthood.

Turin became the capital of the kingdom of Sardinia in 1720, sixteen years before Lagrange's birth. His family had French connections on his father's side. His grandfather was a French cavalry captain who had left France to work for the Duke of Savoy. For this reason, Lagrange always leaned towards his French ancestry. When he was young, he signed his name Lodovico LaGrange or Luigi Lagrange, using the French form of his family name.

Lagrange's interest in mathematics began when he read a copy of Halley's 1693 work on the use of algebra in optics. He was also attracted to physics by the excellent teaching of Francesco Ludovico Beccaria (1716–1781) at the College of Turin, leading him to decide to follow a career in mathematics.

*Mécanique Analytique* was written by Lagrange during his period in Berlin and was approved for publication by a committee from the Academy of Sciences consisting of Laplace (1749–1827), Cousin, Legendre (1752–1833) and Condorcet (1743–1794). This book summarized all the work done in the field of mechanics since the time of Newton (1642–1727), being notable for its use of the theory of differential equations. In 1810, Lagrange commenced a thorough revision of his

**Fig. 1** Joseph-Louis Lagrange (1736–1813)



masterpiece, but he was able to complete only about two-thirds of it before his death in Paris on April 10, 1813. He was buried in the same year in the Panthéon in Paris. The French inscription on his tomb reads:

Joseph-Louis Lagrange. Senator. Count of the Empire. Grand Officer of the Legion of Honour. Grand Cross of the Imperial Order of the Reunion. Member of the Institute and the Bureau of Longitude. Born in Turin on 25 January. Died in Paris on 10 April 1813.

### 3 Science and the French Revolution

The French revolution has great importance as a fundamental transformation of European society from the social, political and scientific viewpoints. Besides the intellectual and cultural changes before the takeover of power by the bourgeoisie in France, with direct consequences for scientific production over a long period of Lagrange's history, we should also mention other factors and aspects of this context.

The first important thing to note is the need of the new regime for new institutions in order to criticize and fight against the ideas of the *ancien régime*. These new institutions also appeared within the educational system as the best way to change mentalities and to prepare new technical and political elite to give continuity to the project of a new society announced by the Revolution.

The transformations in the educational system of France implied significant modifications in technical and professional education, because new creeds, new

knowledge and new technologies had emerged, making it necessary to teach them. The development of engineering and its teaching is important in this context. A reformation of engineering instruction was also necessary because war with other European countries had stimulated the construction of fortifications, roads and bridges, and the development of artillery. This new context propelled France to apply scientific principles to industry, with the result that the new engineering had to provide universal scientific knowledge, as well as tools and methods applicable to a diverse range of practical situations (Belhoste 2003). As we know, Lagrange played an important role in the context of these transformations. He was the first professor of analysis, appointed for the opening of the *École Polytechnique* in 1794. In 1795, the *École Normale* was founded with the aim of training school teachers. Lagrange taught courses on elementary mathematics there.

## 4 Historical Considerations in *Analytical Mechanics*

### 4.1 *First Part: Statics*

Lagrange began his history of statics by defining this discipline associated with the concept of force. He states:

Statics is the science of forces in equilibrium. We think, in general, of force or power as a cause, anything that impresses or tend to impress motion on the body under consideration; it is also by the quantity of impressed motion, or by its tendency, that a force or power must be estimated.

According to him, the objective of statics is to provide the laws that govern equilibrium. In this sense, equilibrium appears as the destruction of several forces that oppose and annihilate them. These laws are based on three general principles, namely: (a) the equilibrium of the lever; (b) the composition of motions; (c) virtual velocities. It is, thus, in the context of the historical development of these three principles that Lagrange rebuilds the history of statics.

Lagrange considers Archimedes (287–212 B.C.) to be the only scholar from ancient times to produce a theory of Mechanics, which is contained the latter's two books entitled *Aequiponderantibus*. Archimedes was also the author of the principle of the lever (Dijksterhuis 1987). In modern times, the contributions of Stevin (1548–1620), in his *Statics*, and Galileo (1564–1642), in his *Dialogues (Discorsi)* about motion, had transformed Archimedes' demonstration into a much more simple and useful concept (Galileo 1988). However, it seemed to Lagrange that ancient mathematicians did not know of a method for generalizing the principle of the lever to other simple machines, notably the inclined plane. This problem was also posed to the first modern mathematicians. Stevin presented the first exact solution to this problem independent of the lever theory. These considerations led him to the impossibility of perpetual motion (See *Elements of Statics and Hypomnemata Mathematica*).



The second fundamental principle of equilibrium is the composition of motions. It is assumed that when two forces are acting in different directions on a body, these two forces are equivalent to one following the diagonal of the parallelogram. In all cases in which there are several forces, the composition of two forces leads to a single force representing the whole system. For the equilibrium condition, this force must be zero if there is no fixed point. This conclusion is found in any book of Statics, particularly in Varignon's new mechanics (Blay 1992). In addition, he derived a theory of machines using this principle alone.

The origin of this principle is attributed by Lagrange to Galileo, specifically in the second Proposition of the Fourth Journey in his *Dialogues (Discorsi)*. Lagrange remarks that Galileo does not consider the full importance of the Principle in his theory of equilibrium.

The theory of composed motions can also be found in the writings of Descartes (1596–1650), Roberval (1602–1675), Mersenne (1588–1648), and Wallis (1616–1703). As mentioned above, Varignon (1654–1722) used this principle for machines in equilibrium. His project of a new mechanics, presented in 1687, had this objective.

Let us look at the third principle, virtual velocities. This is understood as the velocity acquired by a body whose equilibrium is not maintained. The principle states that, for the equilibrium, the powers are in inverse ratio to the virtual velocities, estimated in the direction of the powers. Lagrange attributes the discovery of this principle to Galileo in his *Dialogues (Discorsi)* (See the Scholium of the second proposition of the third Dialogue.). In this context, Galileo also defines the *moment* of some weight or of some power applied to a given machine as an action, energy, or *impetus* to move the machine in a way that equilibrium is maintained between two powers with the condition that the moments are equal and in contrary sense. The moment is always proportional to a power (force) multiplied by its virtual velocity.

This notion of moment that came from Galileo was adopted by Wallis in his *Mechanics*, published in 1669. He emphasizes the principle of equality of moments as the main foundation for Statics, and thus applies this theory to machines. In parallel, Descartes summarizes Statics in a unique principle, which, in fact, is the same as proposed by Galileo, though presented in a new and general form. This principle is based on the force necessary to elevate a weight to a height. Afterwards, it was used extensively to evaluate the capacity of a given machine or to compare machines with different capacities. The birth of applied mechanics, mainly through the work of Lazare Carnot (1753–1823), uses this mechanical model extensively (Oliveira 2012).

Another important principle described by Lagrange is Torricelli's principle. He was a famous disciple of Galileo and his principle is directly related to Galileo's concepts, in some cases being a direct consequence of Galileo's analysis. The principle states that when a system of bodies is in equilibrium, its center of gravity is in the lowest position. In the condition of equilibrium, the center gravity cannot go up or down due to infinitely small variations of position.

Lagrange enunciated the principle of virtual velocities in a general form as follows:

If in any system of bodies or material points, any one of them is submitted to forces, but the system is in the position of equilibrium and therefore we apply any small motion, as a consequence each point describes an infinitely small space which will express its virtual velocity; the addition of all forces multiplied by the displacement of its points of application following the direction of the force will be always zero, since we adopt as positive the displacements in the direction of the forces and as negative the displacements in opposite sense to the forces.

Lagrange also remarks that Jean Bernoulli (1667–1748) was the first to realize the great generality of the principle of virtual velocities, as well as its usefulness for solving statics problems. He mentions the letter addressed by Jean Bernoulli to Varignon in 1717 concerning this principle and other important developments, such as that of Maupertuis (1698–1759), who, in 1740, proposed to the Paris Academy of Sciences the name of the *Law of Rest*, and Euler, who developed it in his Memorials to the Berlin Academy in 1754.

## 4.2 *Second Part: Dynamics*

As in the previous section, Lagrange begins this topic defining dynamics by the effect that forces can cause on bodies, by accelerating or decelerating them. In addition, this science was entirely developed by modern mathematicians and physicists. Again, the name of Galileo arises as the one who presented the first fundamental concepts of dynamics. In addition, Galileo developed the kinematics of the free fall of heavy bodies, in which the law of inertia is also constantly present in the free fall, but so is the motion of projectiles. Before Galileo, forces were only discussed in the context of equilibrium conditions. In spite of the simplicity involving the falling of heavy bodies and the motion of projectiles, the determination of the laws governing these phenomena were unknown until Galileo. He took the first step and opened the way to advancing mechanics. Lagrange then refers to Galileo's masterpiece, calling it the *Dialogues About the New Science*, published in Leiden in 1637. Obviously, he means the *Discorsi*.

Following the development of mechanics, Lagrange studied Huygens' (1629–1695) contributions, especially the latter's findings on pendulum motion and the mathematization of centrifugal force, which were fundamental steps towards the discovery of universal gravitation. Huygens' construction of a bridge between Galileo and Newton was of great importance (Taton 1982).

Mechanics became a new science due to Newton's book known as *Mathematical Principles*, which appeared for the first time in 1687. With the invention of infinitesimal calculus, it was possible to transform the laws of motion into analytical equations.

The theory of motion produced by driven forces is based on general laws of any motion impressed on a given body. These laws are derived from known principles,

inertia force and composed motion. As in statics, Lagrange looks for general principles governing phenomena of dynamics using the category of force as a unifying concept. Thus, he identifies these two already-mentioned principles as the most general and fundamental. It is in the context of these two principles that Lagrange develops his historical considerations.

Galileo realized that the first principle enunciated and was derived from the laws governing the motion of projectiles through the composition of horizontal motion with constant velocity with the vertical up and down motion modified by gravity acceleration. The case of falling bodies with the velocity acquired being proportional to the elapsed time, or the vertical displacement proportional to the time squared, was an important achievement made by Galileo using geometrical considerations, in addition to experimental measurements with inclined planes.

After Galileo, Huygens discovered the laws of centrifugal forces of bodies in circular motion with constant velocity, and used this knowledge to compare forces. As a result, weight on the surface of the earth could be calculated as a centrifugal force. This was done in his *Horologium Oscillatorium*, published in 1673 (Huygens 1673).

Newton generalized this theory to any kind of curve, thereby developing the science for varied motions with accelerated forces. He used a geometrical method and occasionally analytical calculation, though instead of differential methods, he applied the series method. After Newton, the majority of mathematicians that developed the theory of motion only generalized Newton's theorems, introducing differential expressions to solve many kinds of problems.

Lagrange then explains how to solve a dynamical problem by using three different perpendicular directions and decomposing forces and accelerations in these directions. The forces in any direction can be calculated by equating on one side forces and on the other the second differential of space divided by the first differential of time squared. For curved trajectories, the decomposition had to be done in normal and tangential directions. Lagrange does not mention that it was Euler who applied this for the first time in 1752 in a manner different from Newton's second law (Truesdell 1983).

Lagrange describes how the problem of shocks between hard bodies was studied, explaining the result of these interactions by means of the analysis of quantities of motion. He mentions that it was Descartes who first realized the principle behind this phenomenon. However, as confirmed by Lagrange, Descartes made a mistake in the application of the principle, because he considered that the absolute quantity of motion was always conserved. After Descartes, Wallis was the first to have a clear idea of the principle and used it to discover the laws for the communication of motion in the context of shocks between hard and elastic bodies, as presented in his *Philosophical Transactions*, published in 1669, as well as in the third part of his treatise *De Motu*, which appeared in 1671.

One of the most important passages of Lagrange's text is dedicated to the d'Alembert principle. The *Treatise of Dynamics*, written by d'Alembert and published in 1743, presented a general and direct method for solving, or at least obtaining, the equations for practically any dynamic problem (d'Alembert 1743/1921).

The method proposed transformed the laws of bodies in motion to its equilibrium, thereby relating dynamics to statics. The principle enunciated by d'Alembert generalizes the work of some previous mathematicians, such as Jacques Bernoulli (1654–1705), with great simplicity.

We can enunciate the principle by studying the motion of various bodies which tend to move with velocities and in a direction so that changes in both are caused by their interactions. It is possible to visualize these motions as composed by what was really acquired and others that are destroyed in the interactions. If we consider only the final motions, the bodies animated with them are in equilibrium.

It is important to emphasize that d'Alembert made useful applications to mechanical problems. However, this principle does not provide the necessary equations for solving different dynamical problems, but rather provides the means to derive the equations from the conditions of equilibrium. Thus, by combining the principle with known principles of equilibrium, such as the lever principle or that of the composition of forces, we can find the equations for each problem with the help of some more or less complicated constructions. The difficulty is in evaluating the forces destroyed.

As discussed previously, the principle of virtual velocities leads us to a very simple analytical method for solving static problems. This same principle combined with the d'Alembert principle also provides a similar method for solving dynamical problems. Explaining this approach in more detail, the application of the principle of virtual velocities consists of the following methodology. For a given system containing several bodies that can be reduced to points being acted upon by any kind of force, if we apply to the system a small motion, each body displaces an infinitesimal space. If we multiply each force by the displacement of its point of application and add them for the whole system, the result is zero.

If we suppose the system is in motion, and considering that the velocities of each body can be decomposed in three fixed and perpendicular directions, the decrease of these velocities will represent the motions lost along the same directions and their increase will be the motions lost in the opposite directions. Thus, these lost motions will be expressed, in general, by the mass multiplied by the element of velocity and divided by the time element, and they will have contrary directions to the velocities. Using this approach, it is possible to obtain a general formula to represent the motions of bodies which will provide a solution for any dynamic problem.

One of the advantages of the above-mentioned formula is that it immediately offers the general equations which encompass the principles and known theorems about the *conservation of living forces*, the *conservation of the motion of the center of gravity*, the *conservation of the moments of rotation motion*, or the *principle of areas* and the *principle of least action*. These principles can be considered the general achievements of the dynamic laws and are the primary principles of this science. With this statement, Lagrange proposed to explain its origins and developments.

The first mentioned principle, the conservation of living forces, was initially presented by Huygens, but in a different form than the one known now. In its origins, the principle represented the equality between the descent and ascent of the

center of gravity of several heavy bodies, in which descending in a group but ascending separately, using the known properties of the gravity center, causes the space displaced by this center in any direction to be expressed by adding the products of the mass of each body by the space displaced in the same direction divided by the total mass. On the other hand, using Galileo's theorems, the vertical displacement of a heavy body is proportional to the square of the velocity acquired in free descent, as well as what can be reached by raising it to the same height. Based on these considerations, Huygens' principle can consider the motion of heavy bodies in which the sum of the products of the masses by the square of the velocities at each time is the same, since the bodies motion may be conjunct in any way, or that they displace freely to the same vertical heights. Huygens made these remarks in a short paper on the methods used by Jacques Bernoulli and the Marquis l'Hopital (1661–1704). Obviously, the principle postulated by Huygens is a particular application of the more general principle of conservation of energy, a concept which would appear only in the middle of the 19th century.

After these achievements, Daniel Bernoulli (1700–1782) derived from this principle the laws of fluid motion in vessels, which had not been previously dealt with. He reached his general principle in the Berlin memorials, published in 1748, in spite that his famous principle appears ten years before (Bernoulli 1968).

The great advantage of this principle is that it easily provides an equation between the velocities of the bodies and the variables which calculate their position in space in such a manner that, due to the characteristics of the problem, all these variables are reduced to one, with this equation being sufficient to solve the problem completely.

The second principle is due to Newton, who, at the beginning of his *Principia*, demonstrated that the state of rest or motion of the center of gravity of several bodies does not change through their reciprocal action. This implies that the center of gravity of the system is at rest or in uniform linear motion unless it meets some exterior obstacle. Obviously, this principle is useful for determining the center of gravity motion independent of the motions of individual bodies, as it can provide three equations between the bodies' coordinates and time.

The third principle, more recent than the other two, seems to have been discovered simultaneously in different ways by Euler, Daniel Bernoulli, and Le Chevalier d'Arcy (1723–1779). According to Euler and Daniel Bernoulli, this principle involves considering the motion of several bodies around a fixed center. Hence, the sum of the products of the mass of each body by the circular velocity around the center is always independent of the mutual action among the bodies and is conserved unless some exterior obstacle is found.

The principle enunciated by d'Arcy, which appeared in the Memorial he presented to the Paris Academy of Sciences in 1746, is that the sum of the products of the mass of each body by the area described by its vector radius around the fixed center is always proportional to time. This principle generalizes Newton's theorem about areas due to any centripetal forces.

Finally, the fourth principle is called the least action, in analogy with Maupertuis' principle of the same name, which had become famous. It involved

considering the motion of several bodies acting among them and then taking the sum of the products of the masses by the velocities and the spaces described as a minimum. Maupertuis had derived this from the laws of the reflection of light and refraction, as well as of mechanical shocks. These studies appear in two Memorials, one presented to the Academy of Sciences of Paris in 1744 and the other to the Berlin Academy (Maupertuis 1744).

Before being completely established as a principle, Euler made the first approach to it in his treatise on isoperimetric curves, printed in Lausanne in 1744, postulating that, in the trajectories described by central forces, the integral of the velocity multiplied by the curve element is always a maximum or a minimum. This property, which Euler did not recognize except for isolated bodies, as he mentioned, was extended to any motion of bodies acting among themselves, leading to this new general principle in which the sum of the products of the masses by the integrals of the velocities multiplied by the space elements is constant and a maximum or a minimum. It is a simple consequence of mechanical laws. This principle combined with the principle of the conservation of living forces following the rules of variational calculus directly provides all the necessary equations for solving each problem, giving rise to a method to solve problems of motion.

## 5 Final Remarks and Conclusion

One of the aims most sought by physicists throughout the years has been the finding of a principle, the simplest possible, or some basic fundamental principles, which could fit all natural phenomena. Some tried to do this, as Lagrange's analysis demonstrates. d'Alembert did the same. In his *Preliminary Discourse* in the *Treatise on Dynamics*, one reads: *If the principle of the inertia of force, of composed motion, and of equilibrium, are essentially different from each other, as we cannot prohibit happening; and if, on the other hand, these three principles are sufficient for mechanics, one can reduce this science to the least number of principles possible, and assume that on these three principles there can be established all the laws of motion for any body in any circumstances, as I have accomplished in this work.*

In his famous *Fundamental Principles of Equilibrium and Motion*, published in 1803, Lazare Carnot states: *There are two ways to see mechanics and its principles. The first one is by considering it as a theory of forces, the causes that impress motion. The second is by considering it as a theory of motions themselves.* Here, an important remark has to be made. Lagrangian mechanics is the development of mechanics using the second approach, the analysis of motions by themselves, as defined by Carnot. However, with respect to the history of mechanics, Lagrange adopts the concept of force to both statics and dynamics to explain its internal development, obviously because of the late development of the other concepts associated with motion that we know nowadays as the methods of energy.

Another important contribution made by Lagrange to the historical considerations of mechanics is that it highlights some developments which are not completely clear in the current literature. One example is his correct interpretation of d'Alembert's principle. As we know, from reading most mechanics or physics textbooks, this principle is always presented as a method for reducing a dynamical problem into one of statics. Lagrange, as in the original version of the d'Alembert principle, only considers the possibility of equilibrium where motions are destroyed. In other words, equilibrium means the conservation of the quantity of motion.

Lastly, the importance attributed by Lagrange in including historical considerations about the development of mechanics in his masterpiece only confirms that the internal development of science is not independent of its historical development.

## References

- Belhoste B (2003) *La Formation d'Une Technocratie*. Belin, 8, rue Féron 75278 Paris
- Bernoulli D (1968) *Hydrodynamics*. Dover Publication Inc., New York
- Blay M (1992) *La Science du Mouvement: De Galilée à Lagrange*. Belin, 8, rue Féron 75278 Paris
- d'Alembert JL (1921) *Traité de Dynamique*, vol 2. Gauthiers-Villars et Cie Éditions, Paris
- Dijksterhuis EJ (1987) *Archimedes*. Princeton University Press, Princeton
- Euler L (1952) *Methodus Inveniendi Lineas Curvas Maximi Minimive Proprietates Gaudentes*. In Leonhardi Euleri Opera Omnia, s. I, vol XXIV, Lausanne
- Galileo G (1988) *Discurso sobre as Duas Novas Ciências*, Museu de Astronomia e Ciências Afins, Rio de Janeiro
- Huygens C (1673) *Horologium oscillatorium* (Trans: Peyroux J, from Latin). Albert Blanchard Library, Paris
- Lagrange JL (1989) *Mécanique Analytique*. Éditions Jacques Gabay, Paris
- Maupertuis PLM (1744) *Accord des Différents Lois de la Nature qui Avaient Jusqu'ici Paru Incompatibles*. Memoires de l'Academie des Sciences de Paris
- Newton I (1952) *Mathematical principles of natural philosophy*. Great books of the Western World, London
- Oliveira ARE (2012) *The role of the concept of work in the development of applied mechanics*. SISFA 2012, Rome
- Taton R (1982) *Huygens et la France*. Librairie Philosophique J. Vrin, Paris
- Truesdell C (1983) *Essays in the history of mechanics*. Springer, Berlin

# Giuseppe Antonio Borgnis and His Handbook of Machine Designs

Marco Ceccarelli

**Abstract** Giuseppe Antonio Borgnis (1781–1863) was an Italian University professor, who contributed to TMM developments both in theory and practice through his teaching, professional activity, and publications. In this paper, his significant 9-volume handbook of machines, which included the first technical dictionary of terminology, is presented with an illustrative approach.

## 1 Introduction

Modern TMM (Theory of Machines and Mechanisms) was established as a result of the demand of industrial engineers at the beginning of the 19th century, mainly with formation in specific academic courses that were established all around Europe.

Giuseppe Antonio Borgnis was among the first pupils of the Ecole Polytechnique in Paris, and when back home he transferred his expertise to the University of Pavia, where he was engaged in a long life of teaching activity. In addition, he contributed to the development of professional skills with publication of a 9-volume handbook on machines that included the first volume on technical terminology to be used in Europe in the 19th century.

This paper is a first attempt to reconsider the figure of Borgnis and his work, along with an aim to reevaluate his contributions to the Italian academic frames in the modern development of theory and technology of machines.

---

M. Ceccarelli (✉)  
University of Cassino and South Latium, Cassino, Italy  
e-mail: ceccarelli@unicas.it



## 2 Biographical Notes on Giuseppe Antonio Borgnis

Giuseppe Antonio Borgnis (Fig. 1) (Ceccarelli 2014), was born on April 15, 1781, in Craveggia (Val Vegezzo in the province of Novara), Italy, from a well-established family, the father, Giovanni, being a banker in Paris. He was well-educated, showing a special interest in mathematical disciplines, and although the revolution of the time affected the family, he was able to graduate as an engineer. He got a position as a naval engineer in Venice, where he gained enough valuable knowledge to write a book on machines in 1809. The expertise apparent in the book led to his being appointed a member of the Venice Academy in 1812. This also granted him the opportunity to go to Paris to attend courses at the Ecole Polytechnique. In Paris, he deepened his knowledge of machine design, both in



**Fig. 1** A portrait of Giuseppe Antonio Borgnis (1781–1863). (His great-grandchild, Massimo Borgnis, is thankfully acknowledged for the portrait and additional biographical notes)

theoretical studies and practical applications. He evolved his views through Monge's approach, so as to propose his own classification on mechanism variety for machine applications. Developing his views in more detail, he published ten books from 1818 up to 1823, a collective handbook on machine design and application that served as a practical implementation of his new classification.

Once back in Italy, in 1826, he got a professor position at the University of Pavia as a temporary teacher of Applied Mathematics. Then, in 1840, he was appointed full professor of Applied Mathematics, also giving lectures on Civil and Road Architecture. Borgnis was elected Rector of the University of Pavia for the academic year 1842–43, as reported in the historical records of Pavia University (1878). Because of his reputation, he was an active member of the Royal Lombard Institute of Science, Humanities and Arts, and a member of the Royal Academy of Turin. He was also granted the honour of Knight of the Order of Saints Maurizio and Lazzaro by the Italian King Carlo Alberto. He died in Monza on August 16, 1863.

He was a well-reputed professor of applied mathematics and civil transportation architecture, combining his interests and activities in theory and engineering designs during the first period of the Industrial Revolution all around Italy, although he himself was in the northeast state within the Austro-Hungarian Empire.

The circulation of Borgnis's handbook was limited, mainly to within Italy, for at least two reasons, namely the rapidly changing political situation and the reduced influence of Italian Universities at international levels.

Just after the Restoration, subsequent to Napoleon's defeat, the Italian political situation was characterized by the re-establishment of the several kingdoms under the influence of different European countries. The changes and state fragmentation are summarized in Fig. 2. After several centuries existing as several small states, the fragmentation reached the status shown in Fig. 2a, referring to 1796 just before the

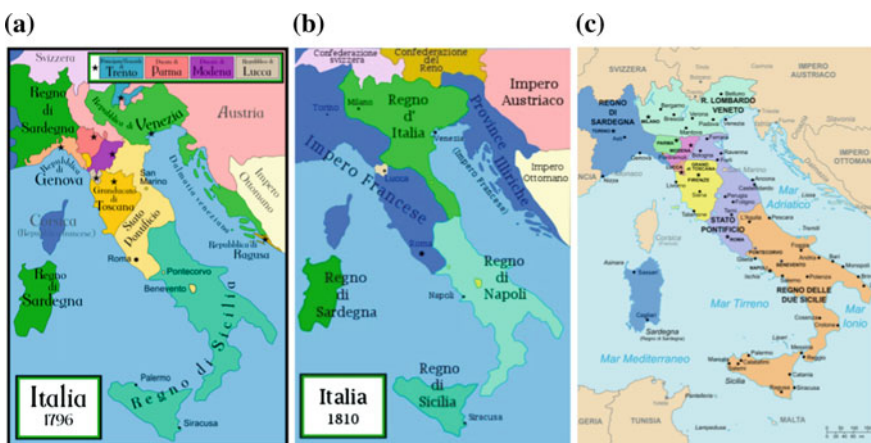


Fig. 2 Italian states in: a 1796; b 1810; c 1840

French Revolution. In Fig. 2b, the political situation around 1810 is represented, with the strong influence of France, as a result of the French Revolution, all over the North and Center of Italy. This is also why Borgnis was attracted to Paris as a place that he might enhance his machine expertise. In Fig. 2c, the restored situation from 1840 is illustrated, showing several kingdoms and North East Italy, which was soon included in the Austro-Hungarian Empire. But at that time, there were already considerable hopes and actions for the reunification of Italy. This is to note that Italian society of the time, although fragmented into several kingdoms, was very directed toward the possibility of a unique Italian kingdom, a goal that was actually achieved over the next two decades through the fighting of several wars and with participation of the population. This somewhat accounts for the fact that, in the subsequent decades of the 19th century, owing to the efforts towards reunification, attention was not paid to the circulation of academic works among those kingdoms, and, indeed, even after reunification, governmental programs for standardization of academic subsystems and consequent professional activities were given far greater emphasis than any attempt to circulate previous works. All this made plans for international collaboration within academic subsystems even more problematic.

Nevertheless, Borgnis's handbook was considered and used as a reference in professional activity. But in teaching and research as well, it served as an inspiration in machine analysis and machine classification, respectively.

### 3 Main Publications by Giuseppe Antonio Borgnis

Herein is a list of the main publications by Giuseppe Antonio Borgnis:

- Handbooks on Machine:
  1. “De la composition des machines” (450 pages, published in 1818) (Fig. 3) (Borgnis 1818a), which contains classification and description of mechanical devices in agreement with the approach proposed by Gaspard Monge. The treatise is accompanied by drawings of 1200 mechanical devices, which are also compared in terms of figure and operational characteristics. The classification is summarized in Tables, which give a synopsis of available mechanisms at that time.
  2. “Du mouvement des fardeaux” (334 pages, published in 1818) (Borgnis 1818b), which contains a description of mechanical design and operation characteristics of the machines that can be used for the transportation and lifting of all kind of weights.
  3. “Des machines employées dans les constructions diverses” (336 pages, published in 1818) (Borgnis 1818c), which describes the design and operation of machines that are used for construction in the field of civil engineering, hydraulic engineering, naval engineering and military applications.

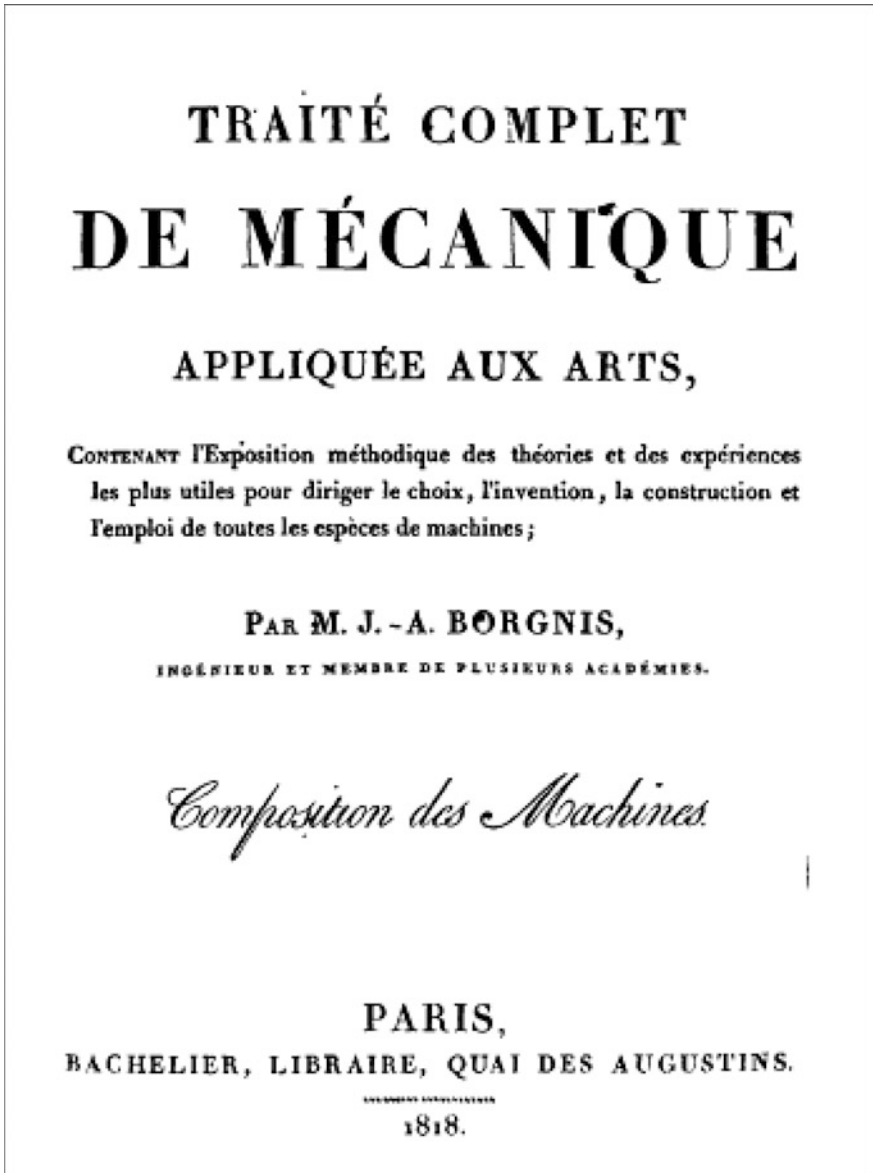


Fig. 3 Title page of the book on Composition of Machines by G.A. Borgnis published in 1818 (Borgnis 1818a)

4. “Des machines hydrauliques” (295 pages, published in 1819) (Borgnis 1819a), which contains an overview of machines that can be used in hydraulic systems. An in-depth study is reported for machines applied in agriculture and mining.
  5. “Des machines d’agriculture” (295 pages, published in 1819) (Borgnis 1819b), which contains descriptions of equipment and machines used in agriculture. Detailed studies are reported on mechanisms that are used for harvesting machines, winding and drilling machines, and devices for production of oil and wine.
  6. “Des machines employées dans diverses fabrications” (285 pages, published in 1819) (Borgnis 1819c), which contains the description of machines used in industrial plants for production of metal components, paper products, textile manufacture, and tannery products.
  7. “Des machines qui servent à confectionner les étoffes” (335 pages, published in 1820) (Borgnis 1820a), which contains descriptions of procedures for spinning vegetal or animal material, comparative analyses of mechanical means for industrial spinning and equipment of different kinds of machines for different kinds of products in textile manufacturing.
  8. “Des machines imitatives et des Machines théâtrales” (285 pages, published in 1820) (Borgnis 1820b), which contains a description of mechanical devices that are used for any kind of transportation or movement, including devices mimicking animal motions. The text includes an Appendix with interesting descriptions of old machines for theatres and how to adapt their use to current needs and other aims.
  9. “Théorie de la Mécanique usuelle” (published in 1821) (Borgnis 1821), which contains an introduction to the mechanics applied to practical industrial applications and refers to principles of Statics, Dynamics, and Hydraulics. Detailed descriptions and formulation are presented on primary mechanical transmissions.
- Terminology Technical Dictionary:  
Borgnis G.A., Dictionnaire de mécanique appliquée aux arts, Bachelier, Paris, 1823 (Borgnis 1823),
  - Other publications:  
1809: Studio delle macchine, Stamperia di Antonio Curti, Venezia (on the study of machines)  
1826: Delle Macchine Idrauliche: I trattati, Tip. Cardinali e Frulli, Bologna (treatises on hydraulic machines)  
1842: Elementi di statica architettonica, Gaspare Trufi Ed., Milano (fundamentals on Statics in Architecture)

Borgnis worked out the 9 volumes (Borgnis 1818a, b, c, 1819a, b, c, 1820a, b, 1821) of his machine handbook as a practical implementation of his classification of

TABLEAUX SYNOPTIQUES DES ORGANES MÉCANIQUES.  
ORDRE CINQUIÈME — RÉGULATEURS.  
CLASSE PREMIÈRE. — MODÉRATEURS

xxvii

ESPÈCES.	VARIÉTÉS.	INDICATION DES		
		Planch.	Figures.	Page.
<b>GENRE PREMIER. — Volans.</b>				
1	Volans à lentilles ou à roues.	26	13	785
2	Volans à palettes.	"	"	"
<b>GENRE DEUXIÈME. — Compensateurs qui corrigent de grandes irrégularités.</b>				
1	Condensateurs de forces.	31	1 et 2	788
2	Fusées.	26	16, 30 et 31	798
3	Courbes tournantes.	31	4	800
4	Contre-poids variables.	13	18 et 19	807
<b>GENRE TROISIÈME. — Compensateurs qui rendent le mouvement uniforme et règlent en même temps sa vitesse.</b>				
1	Échappemens à recul.	30	5	826
		26	22	827
		30	6	828
2	Échappemens à repos.	26	25	830
		30	7	832
		26	24	834
3	Échap. à vibrations libres.	30	3	831
		26	27	840
4	Échappemens à remontoir.	26	28	842
		26	29	844
<b>CLASSE DEUXIÈME. — DIRECTEURS.</b>				
<b>GENRE PREMIER. — Stateurs.</b>				
1	Stateurs réguliers.	27	1, 2 et 3	850
		30	2	857
		30	1	864
		"	"	870
2	Stateurs dont les suspensions variables sont cependant assujetties à des loix fixes.	28	1 et 2	873
3	Stateurs variables et libres qui produisent simultanément une suspension dans un sens et un renouvellement de mouvement dans un autre sens	27	6	877
		27	8	881
		31	3 et 11	882
		17	14	883
		26	14 et 15	884
		17	13	885
4	Stateurs libres qui ne produisent qu'une simple suspension	31	12	886
		31	5	"
		"	"	887
		31	13	887
		31	9	888
		31	6 et 7	889

Fig. 4 Beginning of the list of regulators in the table of machine classification in the book on Composition of Machines by G.A. Borgnis, Fig. 3 (Borgnis 1818a)

machines and mechanisms. He derived his classification as an extension of Monge’s classification published in the book by Lanz and Betancourt (1808). Borgnis’s criticism of Monge’s classification, that was based on the possibility of motion for input-output relationships, is completed by a view of practical engineering based on his professional experiences. Thus, in 1818, in his first book on *The Compositions of Machines*, Fig. 3 (Borgnis 1818a), he introduced a classification for the functioning of machines and mechanisms. He classified the machines in categories, namely Receivers, Communicators, Modifiers, Frames, Regulators, and Operators. Each category was organized into classes, a list of which is summarized in the tables at the beginning of the book, as shown in the example in Fig. 4. The structure of Borgnis’s classification is summarized in Table 1, with indication of the number of considered machines and mechanisms.

The last book of the Handbook is focused on the terminology, serving as the first technical dictionary in the form of a very early standardization of technical terms.

The Borgnis classification was considered in the next developments in machine classification, as cited, for example, by Willis (1841), as a basis for his improved views. The approach of analyzing machines and their mechanisms was also considered a reference for textbooks, like for example, for the book written by Carlo Giulio in 1841 (1846) at the school of engineering in Turin. Borgnis’s work was well known in the 19th century, but it was quickly forgotten within Italian academic fames, as indicated, for example, by its omission in the background for machine classification in the work by Francesco Masi (1883) in Bologna.

Nevertheless, the value of the Borgnis technical handbook, that is completed with the terminology dictionary, was considered of inspiration for several machine books, even in the second half of the 19th century, although not always explicitly cited. In addition, it was used as a technical reference for professionals for the entire 19th century.

**Table 1** Structure of Borgnis classification of machines and mechanisms, Borgnis (1818a)

Category	1					2		3					
Class	1	2	3	4	5	1	2	1	2	3	4	5	6
Genre	2	8	3	4	2	4	4	3	2	2	2	2	1
Type	16	17	10	7	8	11	7	6	4	5	6	4	1
Machines	45	28	18	10	11	59	27	7	10	11	8	10	1
Category	4				5			6					
Class	1	2	3	1	2	3	1	2	3	4	5		
Genre	3	2	3	3	3	3	4	5	3	2	5		
Type	8	7	9	10	7	8	13	9	9	13	19		
Machines	17	29	15	16	24	8	67	20	24	36	25		

## 4 An Illustrated Survey of the Handbook Collection

The collection of machines in Borgnis's handbook is organized within the tradition of *Theatrum Machinarum*, but with much greater technical content, as befits a book directed at experts in the fields of machinery. Each machine's design structure is described with operational characteristics outlined, and is supplemented by typical design drawings that are collected in tables at the end of each book. This description allows for derivation of formulations that do not appear in the text. Machines are grouped in each of the seven books of the collection published after the first book by their specific fields of application. The last additional book is devoted to theoretical aspects of the mechanical functioning of machines through the outlining of basic principles of Mechanics for design and analysis purposes, including formulation in the specific forms of the time that would need interpretation for modern expression.

The survey of machines in each book is completed with the most recent machines of the time, all of which were steam-powered machines. In his handbook of machines, Borgnis started with machines whose operation is based on human actions, with an early biomechanical approach. The value of human operation is recognized as necessary in some operations for which the machines cannot efficiently help or substitute for humans but are still a part of the task frame. This analysis also gave him the ability to consider solutions with what we would today call biomimetics design.

The illustration-based survey in this chapter, with Figs. 5, 6, 7, 8, 9, 10, 11, 12, 13 and 14 showing examples of the variety of machine solutions that Borgnis reports, can allow the reader to appreciate the book's encyclopaedic views, as well as the details that are used in the technical representations for each single machine and mechanism.

Figure 4 shows an example of the tables in (Borgnis 1818a) listing machines and mechanisms under Borgnis's classification, where each category is given with indication of the sub-classification, as indicated in Table 1. The reader can appreciate the way each category name is indicated, along with the other details of the classification. In particular, each machine unit is indicated in a row with a specific short descriptive name after a general group name, the referring table and figures also being listed together with the paragraph's location in the book. The figures are grouped into tables that are at the end of the book, as was the publishing tradition of the time.

Figure 5 is an example of a collection of simple mechanisms as components of more complex machines. In this table, attention is focused on mechanism schemes for mechanical transmissions as the most common mechanism types, such as linkages, cam systems and geared transmission, with synthetic drawings of design purposes that somehow include indication of the operation capabilities.

The two tables in Fig. 6 are examples of machines that are analyzed in the main book (Borgnis 1818a) and they show the importance that Borgnis gives both to simple human-actuated machines and the most recently developed steam powered



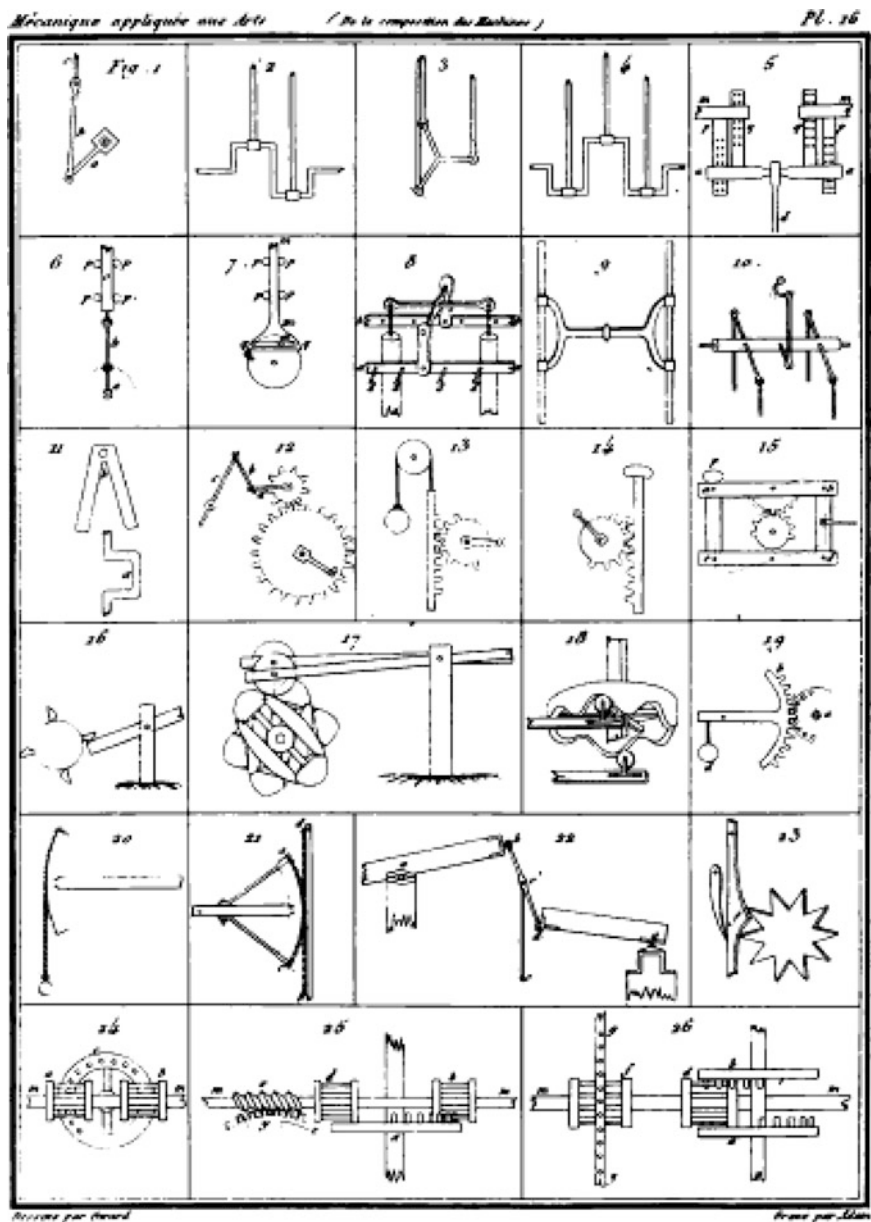
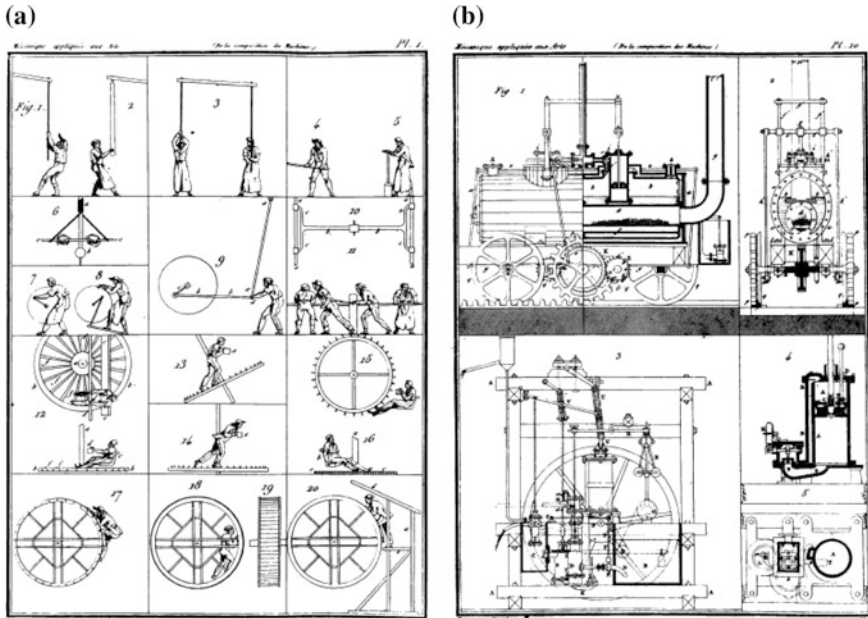


Fig. 5 Mechanism collection in the book on Composition of Machines by G.A. Borgnis in Fig. 3 (Borgnis 1818a)

machines of the time. Indeed, the human-powered machines in Fig. 6a are discussed not only for historical background but also to indicate the size of those basic machines and their standard power capability (with one or more humans in action). In Fig. 6b, the most modern machine of the time is illustrated with two emblematic examples, namely a locomotive and an industrial installation for power production. Both machines are drawn with a general mechanical design in which only some of the mechanisms are reported in detail.

Figure 7 shows two tables from book (Borgnis 1818b) in which components and grasping devices are shown lifting weights in different applications. In Fig. 7a, attention is addressed to the several solutions of pulley-cable unit with a mechanical design that works for compact efficient solutions. At the bottom of the table, the process for transporting and lifting an obelisk through the use of capstans with vertical axis for human actuation is shown. In the table of Fig. 7b, a collection of different grasping solutions are shown with mechanical drawings for practical implementation.

Figure 8 shows examples from book (Borgnis 1818c) of machines that are used in construction. The table in Fig. 8a shows solutions from elementary tools up to complex machinery. At the top of the tables, tools for manual operation are drawn, many of which resemble those still in use nowadays. Then, complex machines used



**Fig. 6** Examples of drawings in the book on Composition of Machines by G.A. Borgnis in Fig. 3 (Borgnis 1818a): **a** basic components with man-powered machines; **b** steam-powered machines

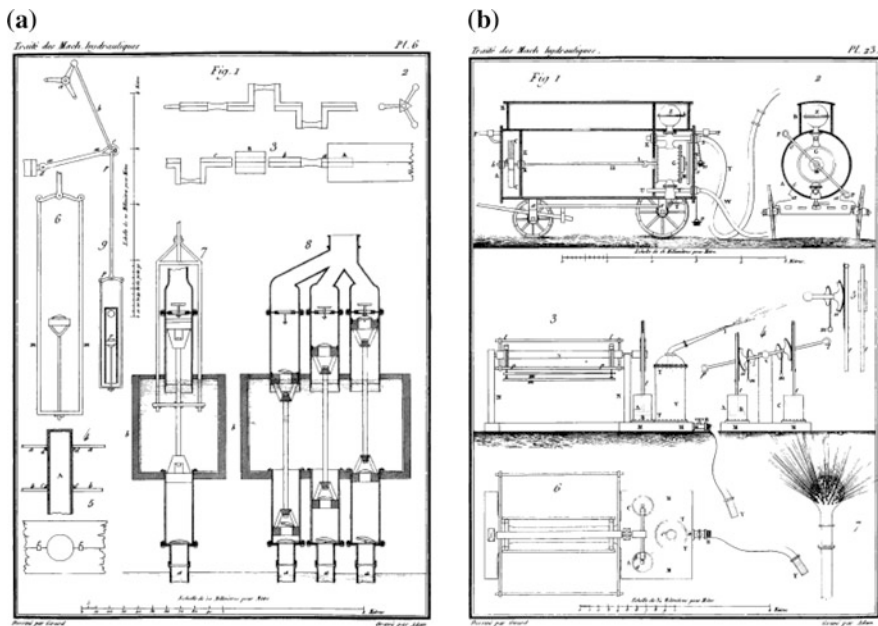


for the purpose of cutting construction elements out of either wood or other materials are illustrated.

The machine is shown with a mechanical design that also includes the hydraulic turbine as a power source. The drawings are composed from two views, namely a lateral perspective and a top view so that all the elements are clearly identified.

Hydraulic machines are specifically addressed in book (Borgnis 1819), since at the time, they were still a major power source with multiple applications. The examples in Fig. 9 illustrate significant examples of applications, namely in Fig. 9a, structures for pumping systems, and in Fig. 9b, solutions for transposable pumping systems. The drawings in Fig. 9a are relative to complex installations of mechanical design which have several pumping mechanisms working in parallel to effect the sort of large water flow that could be needed for cities (including king houses) and industries. The solution for a single-pump structure emphasises the guiding mechanism and the design size of the stroke element. Figure 9 shows the solution for a car that very likely could be used for firefighting applications. The other installations shown in the table are drawn with modular design, with differentiated elements and the power output of the hydraulic machine synthetically represented by the fluid flowing out of the end-effector of the machine.

The mechanization of agricultural activity is addressed specifically in book (Borgnis 1819) with machines that are designed for simple tasks and more industrial-like solutions. The examples in Fig. 10a refer to simple machines for

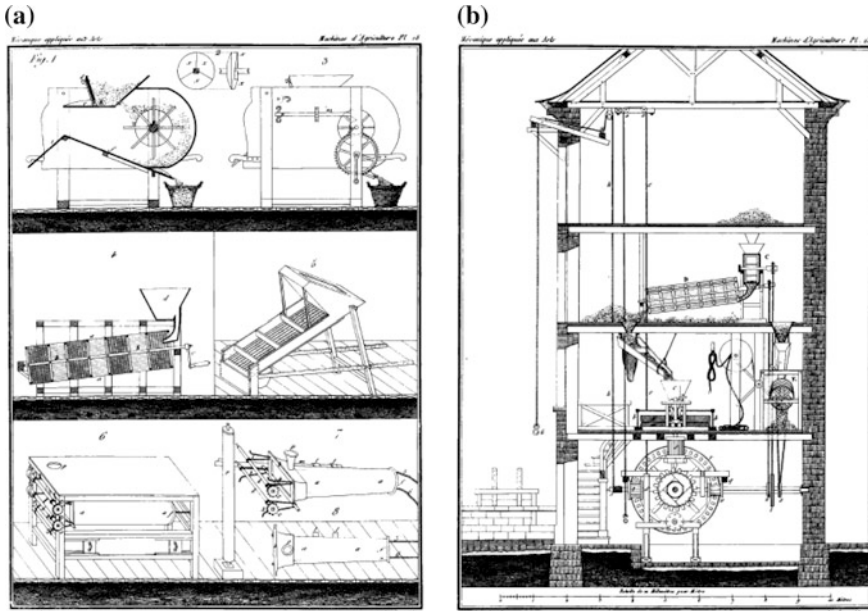


**Fig. 9** Examples of machine drawings in the book on Hydraulic Machines by Borgnis (1819a): **a** composed pumps; **b** fire-fighting applications

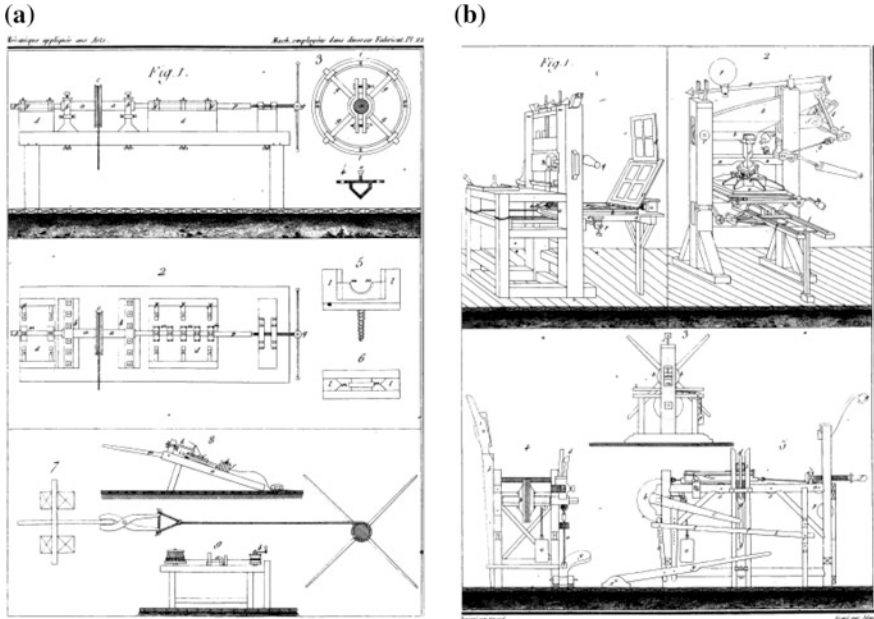
specific actions in the treatment of agricultural products through the use of fairly simple devices with transportable solutions. Figure 10b shows a mill structure with all its parts included in a large building. It is worth full to note that the drawing includes the crane for lifting the products to be milled and even the hydraulic turbine for the power source. Of course, primary attention is focused on the milling machine on the second floor of the building. However, the milling mechanism is not clearly represented, while the mechanical transmissions from the turbine to the milling machine are, shown with a gear system for the main power flow and cable systems for complementary machines in the milling building.

Figure 11 shows examples from book (Borgnis 1819) of machines built for manufacturing activities in several fields of developing industries. In particular, Fig. 11a illustrates machines for cable production that can be powered by proper power sources. In Fig. 11b machines for printing are shown with solutions that are still devoted to human manual actuation. However, the mechanism solutions are evolved in quite complex assemblies both for work precision and force transmission suitable for human operators.

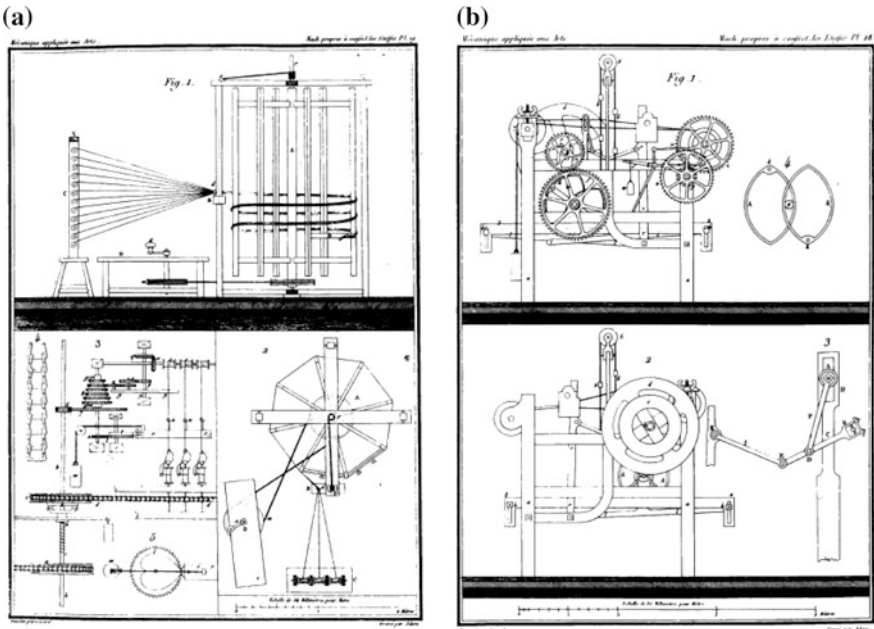
Specific attention is dedicated to textile manufacturing in book (Borgnis 1820) as one of the fields that experienced considerable advance in the early stages of the Industrial Revolution. The examples in Fig. 12 show the complexity of the machines having mechanical designs suitable for a certain automation and machine-powered solutions. Thus, the examples in Fig. 12a are relative to machines



**Fig. 10** Examples of machine drawings in the book on Machines for Agriculture by Borgnis (1819b): **a** machines for separation/selection of products; **b** mill machinery in a milling building



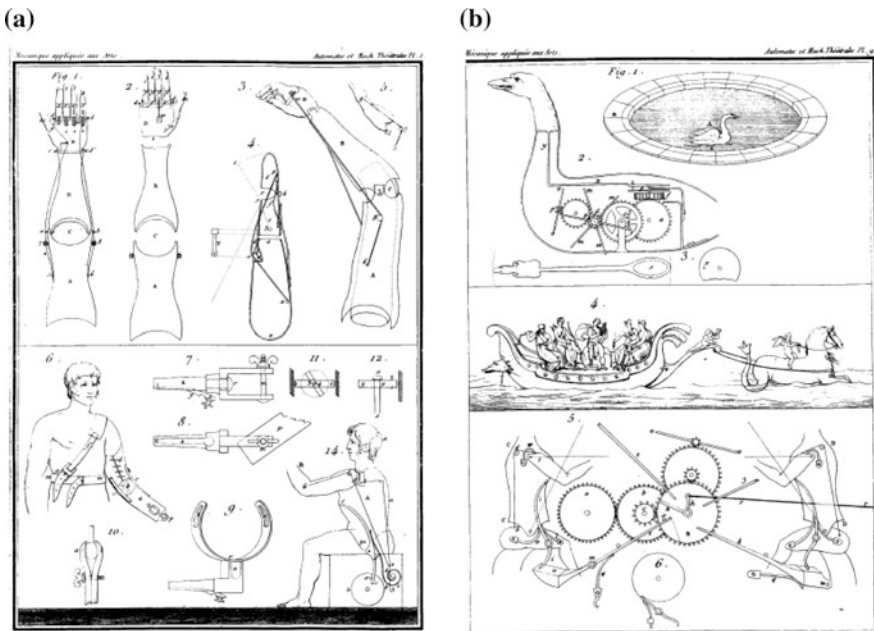
**Fig. 11** Examples of machine drawings in the book on Machines for Manufacturing by Borgnis (1819c): **a** machines for cable production; **b** printing machines



**Fig. 12** Examples of machine drawings in the book on Machines for Textile Production by Borgnis (1820a): **a** machines for thread composition; **b** mechanical loom

for the preparation of treads with different characteristics, while the examples in Fig. 12b concern the mechanical design of looms increasingly based on linkages and gears with the aim of improving both the automation and productivity of textile manufacturing.

The increasing expertise in machine design with automatic operation and advanced characteristics gave increasing importance to the design and use of automata for something other than leisure, as it had been used in the past. Thus, book (Borgnis 1820b) is specifically devoted to automata, although most of the practical applications are still directed toward theatre plays. The examples in Fig. 13 show solutions that can be even recognized as early examples of robots and modern applications. In fact, in Fig. 13a, devices are illustrated that can be recognized as applicable for prosthesis in arms and hands. The mechanical solutions are illustrated with joint designs and compact mechanical transmissions that are indicated for use by humans, but they can be understood as part of more complex artificial constructions. Thus, in Fig. 13b, automata are shown that have fully automatic operation with rational solutions, such as those seen in Vaucanson's duck, and new solutions, like the marine chariot driven by a horse, as basic characteristics of a machine collection representing both the past and the novel solutions. Significant is the exploded view at the bottom of the table in Fig. 13b that is related to the mechanical design of a humanoid with mechanical elements such as gears and linkages.

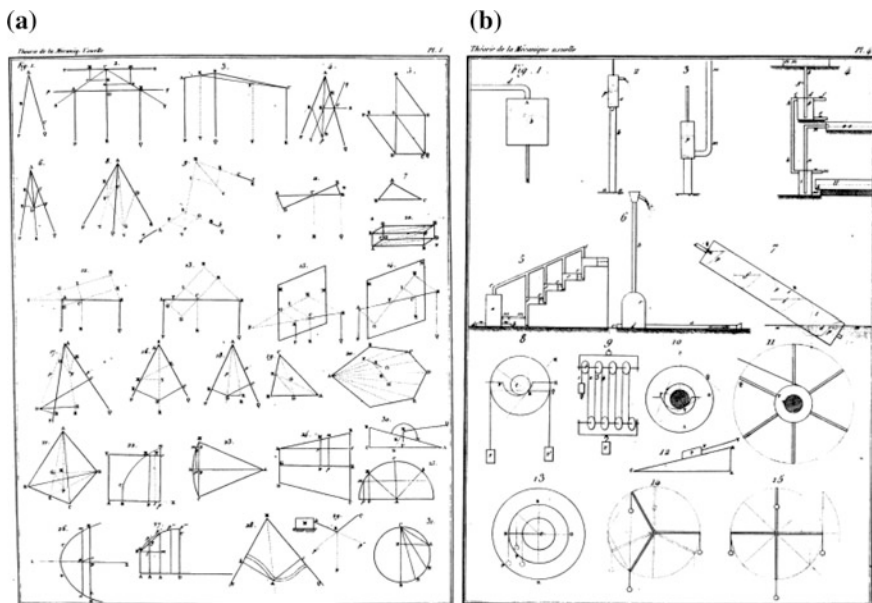


**Fig. 13** Examples of machine drawings in the book on Machines for Automata and Theatre by Borgnis (1820b): **a** basic components; **b** mechanical design of past automata

In Fig. 14, examples are given from book (Borgnis 1821) that are devoted to theoretical analysis of machine operation and design functionalities through specific studies for numerical evaluations with an early modern approach. Thus, in Fig. 14a, several kinematic schemes are drawn for analyzing motion properties and capabilities of mechanisms and machines. In Fig. 14b, mechanical models are elaborated for analyzing the force transmission in those machine elements. The aim of the book is to give schemes and procedures for analyzing and evaluating the mechanical operation of machinery.

The technical collection of machines led Borgnis to the need for a commonly accepted terminology for machinery as a natural complement to the language of the graphical representations. The 10th volume of the handbook (Borgnis 1823), Fig. 15, focuses on terminology and it can be considered a milestone work, being the first technical dictionary on mechanical engineering specifically focused on machines, as Borgnis himself stated in the book's preface. The terminology collection in the book was aimed at summarizing the most frequently used and most well-defined and accepted terms in machinery at the time. The terminology by Borgnis contains technical definitions and operation descriptions with theoretical background, including historical notes and indications of common applications.

The machine term is described by Borgnis as a "general name that is used for several combinations of mechanical devices which are used frequently in Industry. Within the Statics treatment, it is possible to distinguish the names of elementary



**Fig. 14** Examples of tables of drawings in the book on Theory of Usual Mechanics by G.A. Borgnis (1821): **a** scheme for motion studies; **b** schemes for statics and force transmission



machines of lever, pulley, inclined plan, screw, wedge and belt machine”. Specific mechanism components are properly indicated; for example, a crank is described as ‘a link that rotates about an axis and at whose extremity is applied a force. There are cranks with simple, double, triple structure’.

In general, Borgnis’s definitions are synthetic, but additional indications are suggested to the reader referring to other similar/linked terms. Specific mentions are given to literature on arguments of a wide topic. For example, in specifying the term ‘steam’ as also referring to steam machines, Borgnis added a rather long list of references on the topic, even mentioning past designers like Watt, Wolf, and Evans. Figure 16 shows an example of a text item referring to the piston element with the full above-mentioned terminology approach (Fig. 15).



**Fig. 15** Title page of the Dictionary of Mechanics Applied Machines by G.A. Borgnis published in 1823 (Borgnis 1823)

**PISTON.** *s. m.* Nom générique d'un plateau cylindrique qui se meut soit dans un corps de pompe, soit dans le cylindre d'une machine à vapeur ou d'une machine soufflante.

Il faut qu'un piston bouche exactement le cylindre dans lequel il se meut, sans cependant occasioner de frottement trop considérable. Les pistons sont environnés ou de bandes de cuir, ou de filasse que l'on comprime entre deux parties annulaires, réunies par des boulons à vis; ou bien des segmens circulaires sont placés sur le plateau du piston, et poussés en dehors par des ressorts; quelques-uns des pistons sont pleins, d'autres ont des ouvertures couvertes par des clapets. Dans ce dernier cas, il est essentiel que les soupapes soient aussi grandes qu'il est possible, sans nuire cependant à la solidité. Les soupapes doivent s'ouvrir avec facilité, et se fermer avec exactitude. (Ouvrages à consulter: Bélidor, *Architecture hydraulique*; — de Prony, *Nouvelle architecture hydraulique*; — Hachette, *Traité élémentaire des machines*; — notre *Traité des machines hydrauliques*, page 44; — *Composition des machines*, page 155; — Oliver Evans, *Manuel du constructeur des machines à vapeur*.)

Fig. 16 Example of terminology in the Dictionary of Mechanics Applied Machines by G.A. Borgnis in Fig. 15 (Borgnis 1823)

## 5 Conclusions

The book collection by Giuseppe Antonio Borgnis (1818–1823) can be considered significant not only as a historical source of reference for machines of his time but also as an early modern approach to the study of the variety of machines for rational design and operation. The rediscovery of Borgnis's handbook collection deserves specific attention, both in analysis of the work and its influence on machine development for design and teaching in the 19th century. The handbook collection is presented in an illustrated survey to show the technical content of the machine descriptions within a frame of original classification that was elaborated by Giuseppe Antonio Borgnis with a modern view. This paper is an attempt to revitalize interest in this valuable work and give all due credit to its author.

## References

- Borgnis GA (1818a) De la composition des machines. Bachelier, Paris
- Borgnis GA (1818b) Du mouvement des fardeaux. Bachelier, Paris
- Borgnis GA (1818c) Des machines employées dans les constructions diverses. Bachelier, Paris

- Borgnis GA (1819a) *Des machines hydrauliques*. Bachelier, Paris
- Borgnis GA (1819b) *Des machines d'agriculture*. Bachelier, Paris
- Borgnis GA (1819c) *Des machines employées dans diverses fabrications*. Bachelier, Paris
- Borgnis GA (1820a) *Des machines qui servent à confectionner les étoffes*. Bachelier, Paris
- Borgnis GA (1820b) *Des machines imitatives et des Machines théâtrales*. Bachelier, Paris
- Borgnis GA (1821) *Théorie de la Mécanique usuelle*. Bachelier, Paris
- Borgnis GA (1823) *Dictionnaire de mécanique appliquée aux arts*. Bachelier, Paris
- Ceccarelli M (2014) Giuseppe Antonio Borgnis (1781–1863). In: *Distinguished figures in mechanism and machine science—part 3. History of mechanism and machine science*, vol 26, pp 41–56
- Giulio CI (1846) *Sunti delle Lezioni di Meccanica applicata alle arti*. Tipografia Pomba, Torino
- Lanz JM, Betancourt A (1808) *Essai sur la composition des machines*. Bachelier, Paris
- Masi F (1883) *Manuale di Cinematica Applicata*. Zanichelli, Bologna
- Pavia University (1878) *Memories and documents for the history of Pavia University and its famous teachers—part 1: series of rectors and professors*, Pavia (in Italian)
- Willis R (1841) *Principle of mechanisms*. Longmans, London

# Tribute to Reuleaux

**Roberto Bragastini**

**Abstract** A tribute to Franz Reuleaux! Why? Let me introduce myself: I'm a mechanical engineer with a degree in philosophy, and a former manager of a world-wide manufacturing company (aluminium die-casting machines, that is to say, machines equipped with many kinematic mechanisms). The Workshop on the History of MMS organized in the field of MMS, (2013 IFToMM PC-21-22 November in Palermo, Italy) gives me the opportunity to dedicate a tribute to Franz Reuleaux, called the father of kinematics. The goal of this, my homage, is to “brush up the memory of Franz Reuleaux”. That’s all.

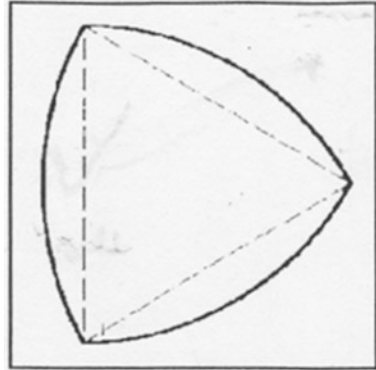
## 1 Introduction

I quote an essay that Prof. Teun Koetsier (Dept. of Mathematics, Faculty of Science, Vrije Universiteit, Amsterdam) wrote in 2000 for the International Symposium on the History of Machines and Mechanisms held at the University of Cassino, Italy, entitled “MMS emerges as a separate discipline. IV, 1”

“Franz Reuleaux.” “...the seventies and eighties of the nineteenth century represent a golden period... the industrial revolution led a continuous stream of new mechanism and machines, in particular, in Germany... the machine is, in the development of mankind, the essential element ... and Reuleaux is one of the first philosophers of technology. He emphasised the need for an independent unified science of machine.—Reuleaux was the first to define mechanism science as a separate discipline with the kinematics of mechanism at its core. In the 1860s, he developed his revolutionary ideas: he distinguishes motion in machines from motion in nature. Reuleaux gives the following definition of kinematics: “The study of those arrangements of the machine by which the mutual motions of its parts are determined. A machine cannot be said to consist of elements but as pairs of element””—Koetsier’s paper.

---

R. Bragastini (✉)  
San Gregorio di Catania, Italy  
e-mail: bragastini.roberto@alice.it

**Fig. 1** Reuleaux triangle

Ferguson, in 1963, wrote about Reuleaux's book "Theoretische Kinematik": "The ideas and concepts introduced have become so familiar to us that we are likely to underestimate his originality."

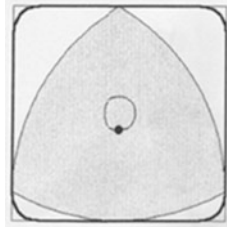
Lastly, I quote Prof. Francis Moon, the Joseph Ford Professor of Mechanical Engineering at Cornell University and currently curator of the Cornell Collection of kinematics models. "Reuleaux is cited as one of the greatest machine theorists."

I chose (see Fig. 1) for this tribute to Franz Reuleaux two of his most particularly original topics, one technical: "the curves of constant width"; the other ethnic: "the distinction between peoples with a highly developed technology and those without."

## 2 Curves of Constant Width

MAYBE, if you please, MAYBE the ingenuity of the curve of constant width cannot be ascribed entirely to Franz Reuleaux: there is some indication of the use of a cam in steam engine regulators and a drawing of Leonardo da Vinci (see Fig. 2), and there was something else made by Leonard Euler, and others. But the history of science is full of writers, inventors, and scientists whose works were put through all kinds of confirmation, denial, and conflicting checks. I can cite from the Bible all

**Fig. 2** Lunate drawing of Leonardo da Vinci



**Fig. 3** The rotation inside the square and the Harry Watt’s square drill

the way up until Newton and even the new field of science in which we do not know if a quantum of light is going to have a left or right split, according to an unclear and short law of probability. But this has nothing to do with my goal of speaking about Reuleaux.

Back to the constant width: it is a shape if the width does not depend on the direction. The curvilinear triangle is built as follows: take an equilateral triangle, drawn with three arcs with radius equal to the side, each centred at one of the vertices; this figure is known as a Reuleaux triangle. (See Fig. 3.)

Rotating the triangle, it covers most of the area of the enclosing square. This area is:

$$S = 2\sqrt{3} + \pi/6 - 3 = 0.98770,$$

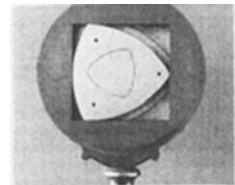
which looks pretty close to 1. (See Fig. 4.)

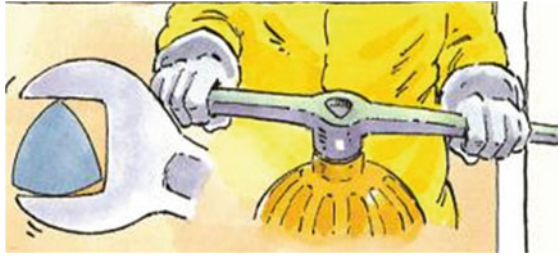
All the triangle curves of height  $h$  have the same perimeter  $2\pi h/3$ . Also, at each position of the triangle, the perpendiculars to the sides at this point of contact are concurrent with the instantaneous centre of rotation.

The mathematical curiosities I can immediately give are (from several books, magazines, newspapers, encyclopaedias, Gaeta notebook, Google, and Wikipedia):

1. Why is the cover of a manhole round? Because a circular lid won’t fall through the opening: it has a constant width. However, the circle isn’t the only curve of constant width.
2. The simplest such curve is the Reuleaux triangle. There is actually an infinite number of such curves, but only if the curves are built from any polygon with an odd number of sides.
3. In 1950, the firemen of Philadelphia chose, for the water cocks, the shape of a Reuleaux triangle (see Fig. 5) to avoid the use of the normal monkey wrench

**Fig. 4** Reuleaux model, Cornell collection of kinematics





**Fig. 5** Wrench shaping by triangle of Reuleaux

(next page). It is thus remarkable that, in 1876, from Philadelphia, Reuleaux wrote his famous letter about production within the German industries with the qualification: “cheap and bad”.

4. List of coins of constant width. Jordanian—Botswanaian—British—Cypriot—Canadian—Mauritian.
5. With which of these curves may it be possible to drill square holes (?—nearly and almost)
6. Why do we want coins to have a constant width? It makes it easier for vending machines to recognize them.
7. The base of the Pepto-Bismol (medicinal preparation) bottle is a Reuleaux triangle.
8. A bike built in 2009 by Mr. Guan Baihua (next page) in P.R.C. (See Fig. 6.)
9. Last but certainly not least (indeed, the most important utilization and exploitation): the Wankel engine.

The Wankel engine is a type of internal combustion engine which uses a rotary design instead of reciprocating pistons. The combustion chamber is an oval, epitrochoid-shaped with a roughly triangular rotor. (See Fig. 7.)

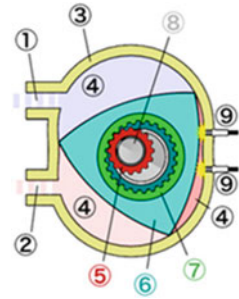
The engine was invented by engineer Felix Wankel (Lahr, August 13, 1902—Heidelberg, October 9, 1988). At the age of 17, he told friends that he had dreamed of constructing a car with a new type of engine, half turbine, half reciprocating. “It is my invention!” he said to them.

True to this prediction, he conceived the Wankel engine in 1924, and won his first patent in 1929.

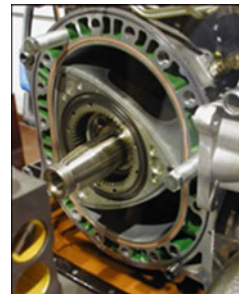
**Fig. 6** Bike with constant width wheels



**Fig. 7** 1 Injection nozzle, 2 exhaust nozzle, 3 external case, 4 combustion chamber, 5 central gear, 6 rotor, 7 internal gear, 8 main shaft, 9 sparking plug



**Fig. 8** Wankel engine



The pictures (see Fig. 8) I have chosen give an easy description of the cycle and the cross section of the motor where the triangle with Reuleaux’s constant width may be seen. The pictures, I think, are more convincing than many words.

Wankel rotary engines have been installed in a great variety of vehicles: automobiles, racing cars, aircrafts, go-karts, water crafts, power units, and, difficult as it may be to believe, “drones”.

Somewhere below you will find a very abundant bibliography (wherever, anywhere, everywhere) about all of the above concerning a lot of points of view I believe to be useless for taking into account the scientists who participated in this workshop, along with equally useless references and acknowledgements.

### 3 Manganismus

As I mentioned, the second part of the tribute to Franz Reuleaux is dedicated to a paper on his work presented at the “Kultur und Technik” conference (or “Technology and Civilization”), which examined the distinction between peoples with highly developed technologies and those without, held in Vienna on November 14th, 1884, for the Industrial Association of Lower Austria, and a second, published in an extra issue of “Glaser’s Annalen fuer Gewerbe und Bauwesen” on February 1st, 1885—b.d. XVI—p. 3—n. 133—Berlin-Lindenstrasse 80; a third published by the German Engineer Association-1885, bd 29—p. 24 and



a fourth in “Cultur und Technik” by Prometheus, Berlin, 1890, bd 1, n. 40; a fifth by Carl Weihe, “Franz Reuleaux und seine Kinematik” 1925; a sixth by W. Kunhardt published in the School of Minea Quarterly 1885, bd 7, p. 67, “The influence of the technical sciences upon general culture,” and a final one, published in Italian, by Maldonado.

I give you the first lines of a few of these papers:

No student of the world’s present state of general culture can have failed to observe the potent influence which the technical sciences of our day are exerting...

From the present status of the world’s culture, one cannot fail to discern the significant influence of our technology in qualifying us ...

Everybody who examines the present status of the civilization cannot notice of the great influence that the pressure by the scientific technology exerts ...

One may believe that the different versions (with absolute conceptual equality) are dedicated to different peoples or readers, but the lecture has attracted a great deal of interest. To explain the reason why I present these lectures, it is necessary to introduce Reuleaux’s ideas through his own similar words.

Do not expect a panegyric of the technics. Let me rather approached some questions:

In the first place, what position do the technical sciences occupy in the active solution of the great problem of general culture?

What, in its leading features, is the general method pursued by the technical sciences in the accomplishment of their ends?

What are the true ends and principles of technical education?

If we will compare our civilization with that of other nations (disregarding those that have not aspired to a written language) one will encounter peoples that for centuries had been the possessors of an advanced degree of culture: Chinese, Japanese, Indians, Persians, and Arabians; then where is the difference in the intellectual sphere that has allowed a separation between them and us? Where do we mark the point of distinction? How is it possible that England with a few thousand of her own troops rules the two hundred millions of India? How has it come to pass that we Atlantic nations are the only ones who have girt the globe with lines of railroad and of telegraph and furrowed the seas with powerful steamships and—the other five-sixths of mankind have not added a span and the same five-sixths are socially organized and highly cultivated? Let us ask, whence is the source of our material preponderance over them?”

I break now from the questions about the culture so as to introduce a marginal note by Reuleaux into the lecture:

It is about time that we should cease from repeating the myth of Omar’s destruction of the Alexandrian library. The capture of the city was not effected by Omar but by general Amru. [Author’s note: he means Amr ibn Al ASI.] The larger part of the library had been destroyed in the year 415 by a conflagration which was fanned into flame by fanatical Cyrillians at the time of unhappy Hypatia’s murder...

This notion was put forward in the year 1884: I can attest to the readers that the historian Franco Cardini, in an article in the July 26, 2009 issue of “Avvenire”, corroborated these facts.

Returning to Reuleaux...

“The spell which bound us was broken by our understanding when we found the forces of nature following in their operations no capricious will but working according to steadfast, unchangeable laws: the laws of nature: Goethe says (Deutsch–English–Italian):

Nach ewigen, ehernen, grosse Gesetzen muessen wir alle, unseres Dasein Kreise vollenden  
According to great laws, eternal, unchanging, we must all our earthly being's cycles complete.

Secondo eteme, grandi e ferree leggi, noi dobbiamo chiudere i cerchi della nostra esistenza

Let me interrupt at this point to say that the “DASEIN” of Goethe that preceded Heidegger’s ideas is extraordinary.

“The forces [getting back to Reuleaux] of nature which that advance taught us to look to for service are mechanical, physical and chemical; but the prerequisite to their utilization was a full equipment of mathematic and natural sciences: The entire apparatus we now apply, so to say, as a privilege. For the convenient designation of two systems serves us to select a special name. A penetration into nature’s secrets was revealed among the Medes and Persians and especially among the tribe of the Magi. Even the Greeks were so imbued with an appreciation of their knowledge that they called any skill device, any magic work that seemed appropriate to the word a “manganon” = μάγγανον, a Greek word from the Indo-European root word ‘mag’ or ‘mang’, as also seen in μάγγανεύμα = catapult, a powerful engine of war, with which the word travelled into the Middle Ages (Italian ‘mangano’, French ‘mangan’, English ‘mangle’). In the 17th century, when large machines were invented for rolling and smoothing linen, and the apparatus happened to possess a catapult, the accidental resemblance gave it its name, passing into all the languages of Europe, so that, as every housewife knows, if she sends out her washing, she is sending it to a “mangle.”

Let me rehabilitate the old word for our purposes and designate “manganism” as being control of the forces of nature and, on the other side, those which seem to stand as nature’s defender, mysteriously guarding her ways, as “naturism”. Indeed, we need not hesitate in asserting that to the manganistic nations belongs the empire of the earth.”

Having come to the end of our Reuleaux quote, at this point, allow me to make remarks and give some commentary:

Klemm (storia della tecnica—Milano-1959-, the industrious Leipzig collector) proposed the distinction between active and passive races.

The word “manganism”, as mentioned above, was of Indo-European origin: Plato in “Gorgia” uses the word to mean spell and sorcery, Herodotus and Stratton said that the Medes were masters of dreams. Maybe the tie between magic and the catapult is not easy to conceive of, but we must remember that the lever (able to raise big weights with small forces) was also thought of as being a deceiver and of magic origin.

Reuleaux quotes the Paduan Zonca in the book “Novo teatro di machine” Padova-1621—p. 34—“mangani, those machines for smooth and shining cloth and linen and an ancient powerful war engine for throwing large stones, darts, and other missiles.”

But Reuleaux had the Medes and the Persians and especially those among the tribe of the Magi in mind when he used the word ‘manganon’ in the lecture of 1884; I must return to “Lehrbuch der Kinematik” (the famous book of the father of kinematics), edited in 1874—Chap. VI—par. 48: “The beginning and the progress of the machines”, as Reuleaux puts it, “the creation of fire by inserting a wooden stick (see Figs. 9 and 10) into a wooden hole represents the first machine from anywhere in the world from any time”, and further, “... the [Greco-Roman] war machine, borrowing from eastern peoples the art of using the power of throwing stones, reached the epitome of perfection ... the turnbuckles (by piles, tendons, rope, naps and bowstring) are made with a special and peculiar flash of genius” (see Fig. 11).

Maybe the creation of manganons was, for Reuleaux, the best technology of the era (see pictures on the next page).

The lecture may appear racist, but it is necessary to understand the words used in the context of 1884: (1) Bismark and his colonial policy; (2) Reuleaux being a member of the Afro-German Association; (3) The second industrial revolution

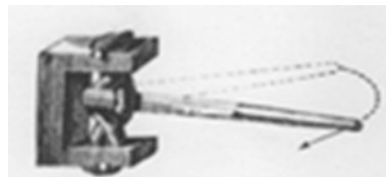
**Fig. 9** Lighting of fire



**Fig. 10** Lighting of fire



**Fig. 11** Turnbuckle



(1830–1890); (4) The extremely rapid population increase (800 million in 1750 up to almost 1200 million by 1850); (5) The life of Franz Reuleaux, as we know it:

1850, Polytechnic; 1852, Universitaet Friedrich II; 1856, machine construction theory; 1879, President Industrial Association; 1870, government adviser at the fairs of London, Paris, Vienna, Philadelphia, Sydney, Melbourne.

I cannot forget that Reuleaux, as a traveller, received the opportunity to write about almost all of mankind’s industrial activities at the time.

Concerning the mangle machine, I would like to tell you about a personal episode: In July of 2002, I was in the midst of a stint as a visiting student at Cornell University, working hard to finish my thesis on philosophy under the tutelage of Professor Francis Moon (the scientist/director of the Reuleaux Kinematic models collection, who was very kind and indulgent with me). We spoke for a long time about the words “mangle” and “manganism”. One afternoon, I had visited a supermarket in Ithaca and had overheard one of two housewives passing by me say to the other: “I have had a lot of trouble with my mangle machine.” (!!!!). A stroke of luck? Pure chance? Philosophical determinism? I don’t know, but I immediately gleaned as much information as I could from the housewife, and now I know that there is a mangle machine made by General Electric!!! (see pictures with Paul Newman and others). (See Figs. 12, 13, 14, 15, 16, 17, and 18).

Continuing with the tribute to Reuleaux, referring to his considerable human and technical resources, I remember that in a lecture called “ueber den Einfluss der Maschinen auf den Gewerbebetrieb” (‘the influence of the machine on industrial operations’), he quoted a poem by Antipater of Thessalonica or Sidon (the source



**Fig. 12** Manganon – Antica Stamperia Marchi 1633 - Santarcangelo (Italy)

**Fig. 13** Mangle machine



**Fig. 14** Mangle machine



**Fig. 15** Mangle machine



**Fig. 16** Advertisement of mangle machines with pin-up girl Belle Ringer



**Fig. 17** Belle Ringer advertises mangle machines on the nose of Liberator B 24 (World War Two)



**Fig. 18** Mangle machine

remains unclear) that calls forth a waterwheel, a mill, cogs, the golden age, one goddess and a bunch of nymphs, and praises the reduction in human labour:

hold back your hand from the mill, you grinding girls  
even if the cockcrow heralds the dawn, sleep on.  
for Demeter has imposed the labour of your hands on the nymphs,  
whollaping (skipping?) down upon the topmost part of the wheel, rotate its axle with  
encircling cogs,  
it turns the hollow weight of the millstones. If we learn to feast toilfree  
on the fruits of the earth, we taste again the golden age.

Long live the memory of Reuleaux!

Of course, I take responsibility for any mistakes I may have made in the many sources I have quoted.

Thank You.

# Elia Ovazza, Professor of TMM in Palermo Around the End of the 19th Century

Marco Ceccarelli, Francesco Sorge and Giuseppe Genchi

**Abstract** In this paper, the figure of Elia Ovazza, professor of TMM in Palermo around the end of the 19th century, is presented, along with his valuable legacy in regard to his activities in teaching, research, design and technology transfer. Short biographical notes outline his foremost life events and an illustrated survey explains his contributions.

## 1 Introduction

The second half of the 19th century can be considered the Golden Age for TMM (Theory of Machines and Mechanisms), since it was in that time that it was developed to high levels of knowledge and practical application. This took place primarily throughout Europe during the Industrial Revolution. But despite a very rich literature, certain relevant works and personalities have been forgotten in the present consideration of the History of TMM. This is the case with most of the Italian literature on Kinematics, and the Italian personalities are only now being re-discovered, together with their contributions regarding TMM success, both in the formation of engineers and research developments with practical applications in new machinery, as pointed out in Ceccarelli (2000, 2014).

While the history of the Mechanics of Machinery, along with its engineering aspects, has been the subject of studies mainly in terms of the history of science and technology, as in Capocaccia (1977), Dimarogonas (1903), Hartenberg and Denavit

---

M. Ceccarelli (✉)

University of Cassino and South Latium, Cassino, Italy  
e-mail: ceccarelli@unicas.it

F. Sorge · G. Genchi

Università degli Studi di Palermo, Palermo, Italy  
e-mail: francesco.sorge@unipa.it

G. Genchi

e-mail: giuseppe.genchi@unipa.it

(1956), Mesini and Mirri (2012), Singer et al. (2012), the history of Italian developments in the areas of the Mechanics of Machinery and TMM (Theory of Machines and Mechanisms) has not yet been given specific attention. In fact, although some works have been addressed specifically in relation to the Italian TMM of the past, as in Angotti et al. (2010), Cardone and La Mantia (2006), Curti and Grandi (1998), Dameri (2010), Della Pietra (2010), most Italian developments in TMM remain unknown to most historians, mainly in terms of personalities and their activities. Recently, attention has been directed specifically at the Italian history of TMM, both in terms of general frames, as in Ceccarelli (2014), Fang and Ceccarelli (2013, 2015), or specific figures, as in (Ceccarelli 2007, 2010, 2014a, 2014b). This paper is part of a project that aims to give a full view of modern achievements in Italian TMM by identifying significant figures in the 19th century and their contributions.

The Italian tradition in the field of Mechanics of Machinery goes back to the field's first studies in the 12th century and continues over the centuries through considerable contributions. In particular, the Mechanics of Machinery was given a great boost by the works of Galilei (1600), Del Monte (1577) in the 16th century, their influence resounding throughout the 18th century as well, as pointed out in Ceccarelli (1998). With this cultural background, new achievements were obtained in the Mechanics of Machinery, so that, in the 18th century, the Mechanics of Machinery and Mechanical Engineering were addressed as separate mature disciplines, independent of Mathematics. Thus, specific books were written and academic courses were established in several Italian Universities, likewise in the rest of Europe. These former developments created a very promising environment for modern enhancements. There are Italian personalities who are recognised and well known from the 17th and 18th centuries, for example, Branca (1629), Grandi (1739), Frisi (1777), Boscovich (1763), cited only for certain books published on the mechanics of rigid bodies and machinery. But the cultural influence of Italian Universities was reduced to the point that, in the 19th century, they were not considered centres of excellence as they had been in previous centuries. Nevertheless, activity continued to be carried out in the field of Mechanical Engineering, mainly with the aim of establishing modern views of the field. Moreover, specific developments were obtained and original contributions were proposed, including some with industrial implementations. However, these works circulated with a certain difficulty, even in Italy, probably because, at the beginning of the 19th century, there was still a considerable number of small kingdoms, and later, the major goal was the attempt to obtain organization through a solidified culture when the Italian nation was unified. Another reason Italian works may have been forgotten can be linked to the fact that the 19th century can still be considered as the recent past in Italian culture, and because of this, it is not yet considered worthy of attention. In fact, in Italian Libraries, the books of the past century are not classified in ancient funds, but neither are they catalogued in the modern database. Most times, they are just stored somewhere. In addition, although memory still exists of past figures, their works are sometimes considered to be out-of-date,



without taking into account their usefulness as an important basis for modern developments.

In the second half of the 19th century, Schools of Engineering were established in most of the Italian Universities, but it was only after the Decree of July 3, 1879 that the course “Kinematics Applied to Machinery” was introduced on a regular basis to the curricula as an important discipline for the formation of industrial engineers (Pugno 1959). Thus, textbooks (sometimes handwritten) can be found as having been published for regular academic courses on TMM or kinematics of machines in Turin, Milan, Padua, Pisa, Bologna, Rome, and Naples, where a tradition was well established within communities evolving toward a national identity. It is worth noting that, after the Italian reunification, there was a great effort to organize academic subsystems, and particularly a common subsystem for the education of engineers all around the country. The most important engineering schools are considered to be those in Turin, Milan, Bologna, Rome and Naples. In those universities, activities were also directed towards promoting the transfer to industrial subsystems, even with direct action of the professors, as reported in Fang and Ceccarelli (2013, 2015). In addition, there were great efforts to disseminate common subsystems, teaching and research, even going so far as to transfer professors from one city to another. This was the case for Elia Ovazza, who moved from Turin to Palermo, where he established a renewed team with significant modern activity in TMM.

In this chapter, the figure of Elia Ovazza is presented through reference to his main works, with the additional aim of showing the impact and significance of his contributions in the fields of Machine Design and the Mechanics of Machinery.

## **2 Notes on the History of the Engineering School in Palermo**

The decree of the Sicilian governor Antonio Mordini of October 7, 1860, after the conquest of Sicily by Garibaldi and just before its annexation into the new Kingdom of Italy, established the School of Application for Engineers and Architects within the Faculty of Physical and Mathematical Sciences of the Royal University of Palermo (Benfratello 2006). This Engineering School took the place of the former School of the Engineering Corps for Bridges and Roads and the Academy of the Chief-Plumbers, which had been founded in the second decade of the 19th century during the Kingdom of the Two Sicilies under the Bourbon kings. This period and its industrial aspects have still not yet been well studied, and attempts are underway to reconsider properly the situation in south Italy (Rossi and Ceccarelli 2013).

The first Engineering teachings were directed towards the fields of Architecture, Hydraulic and Mining Sciences, since they represented the bulk of professional requests from the Sicilian territory, because of the prevalent entrepreneurial

activities of the people in civil construction, agriculture production, and sulphur extraction.

But it was only at the end of the 19th century that the director, Prof. Michele Capitò, succeeded in introducing an industrial section into the School that was motivated by the industrial development in Sicily, as in many other European countries. In particular, very successful development was underway in Sicily, mainly through the economic power of the Florio family, whose members were rich traders and ship-owners. Since they were married to members of the Sicilian aristocracy, they enjoyed good relations with many reigning European houses, such as Romanov, Savoia or Hohenzollern, so that they were capable of spearheading significant activity throughout many European countries, in addition to their prominent entrepreneurial capabilities at home.

The arrival of Elia Ovazza from Turin at the Royal University of Palermo should be understood as taking place in that period of considerable ferment and successful evolution, which was destined to die out with the advent of World War I. Professor Ovazza was asked to teach “*Meccanica Applicata alle Macchine a Vapore*” (Mechanics of Steam Machines) at the School of Application for Engineers and Architects. Yet, his educational and research activity in Palermo lasted for nearly another three decades, until his retirement in 1927 (Ajovalasit and Tschinke 2006).

### 3 Biographical Notes

Elia Ovazza (Fig. 1) was born in 1852 in Turin and was educated in Civil Engineering at the Royal School of Engineering of the University of Turin (today the Technical University of Turin) where he received his engineering degree on October 8, 1876.

After professional experiences in and around Turin, while he maintained ties with academia as an assistant/pupil of Prof. Scipione Cappa, he was given a position as a professor in Palermo in 1899. He moved his family there, where they became so fully integrated into the social community, it became their new home base. The last three of his six grandchildren were born in Palermo, and to this day, his descendants continue to live in Palermo and Sicily.

He continued his academic career with intense activity in Palermo until his death in 1928, just after his retirement in 1927.

Although he centred his activity in Palermo, he continued to have contact with other universities in Italy. In particular, he had a specific teaching duty through the years 1907–1926 at the Royal School of Engineering of the University of Napoli, where he published books on bridges in 1899 and Machine Design in 1922.

The activity of Elia Ovazza, in teaching, design, and application of TMM (Theory of Machines and Mechanisms), can be thought of as typical of the period, during which formation of industrial engineers centred around TMM and industrial developments were based on machine designs with a strong basis in TMM research.

**Fig. 1** Portrait of Elia Ovazza (1852–1928), professor of Mechanics of Machinery in Palermo (The grand-child Elena Ovazza is gratefully acknowledged for the photos and additional biographical notes)



Elia Ovazza can be considered a brilliant Italian example of dedication to the academic teaching mission in the field of TMM. He established a well-respected tradition in Palermo in the area of mechanical engineering with a strong link to the surrounding community but also with consideration for the Italian national sub-systems. As proved by several documents still stored in the archives of the Museum of Engines and Mechanisms at the University of Palermo, (Monastero and Genchi 2012), during his stay in Palermo, Prof. Ovazza also carried out researches involving several experimental studies in the field of reciprocating internal combustion engines, with particular interest in synthesis gas stationary engines.

#### 4 Main Publications and Activities

In conjunction with the courses he taught, Ovazza prepared and published his lecture notes, as seen in the following list:

- On Bridges, 1899, (Ovazza 1899)
- Mechanics of Machinery—Kinematics, 1900, (Ovazza 1901)
- Shocks and Explosions—Lectures on Applied Dynamics, 1902, (Ovazza 1902)
- Mechanics of Machinery—Machines, 1907, (Ovazza 1907)

- Mechanics of Machinery—Steam Machines, 1908, (Ovazza 1908)
- On Hydraulic and Thermal Machines, 1919, (Ovazza 1919)
- Machine Designs, 1922, (Ovazza 1922)
- Lessons on Railways 1922–1924, 1924, (Ovazza 1924)

The works in the next list, related to the design activity that he linked to his research interests, show a wide range of expertise and results that, indeed, left a durable memory of his achievements:

- Ovazza E., The funicular polygon in Kinematics, Proceedings of the Royal Academy of Science of Turin, Turin, 1890, (Ovazza 1890).
- Ovazza E., Contribution to the theory of pneumatic springs, Proceedings of the Royal Academy of Science of Turin, Turin, 1902.
- Ovazza E., A study on the potentiality of railways, Journal of Railways and tram-ways, Milan, 1902.
- Ovazza E., An elementary explanation of functionality of injectors, Journal II Politecnico Milan, 1902.
- Ovazza E., Influence of springs on dynamic stresses, Journal Civil Engineering and Industrial arts, Turin 1902.
- Ovazza E., On water meters, Milan, 1905.
- Ovazza E., On a new design procedure of flywheels, Journal Monitore Tecnico, Milan, 1905.
- Ovazza E., Ergonomic instruments for very rapid engines, Journal Eletttricista, Roma, 1905.
- Ovazza E., Improvements of technical efficiency of steam engines, Journal Eletttricista, Roma, 1905.
- Ovazza E., Ergonomic experiences at the Institute of Machines of Royal School of Applications for Engineers in Palermo, Palermo, 1905.
- Ovazza E., Sicilian sources for Energy power, Journal La Sicilia Universitaria, Palermo, 1905.
- Ovazza E., Gas machines by Prof. Ferrero, Journal Monitore tecnico, Milan, 1905.

Particularly remarkable was his approach for teaching mechanism design and design results in machine developments.

Ovazza's teaching activity was mainly directed toward the fundamentals of TMM and design procedures for mechanisms and machines, including experimental validations, as documented by/in his lecture notes and the textbooks in the list above (Figs. 2, 3, 4, 5 and 6). He gave special attention to the fluid dynamics of machines as related to steam power engines.

In particular, he presented the Theory of Kinematics and Dynamics of machines by combining graphical procedures with analytical formulation, both for a characterization and design of machines with an approach that, although typical of his time, was based on his personal expertise and direct experiences. He linked the teaching with research and design activities for technology transfer, not only in the



Fig. 2 Title pages of the first teaching work by Elia Ovazza from his experiences in Turin

Sicilian region, but also with experimental activities of investigation and validation that took place at the Laboratory of Engines that he founded in Palermo.

Figure 3 shows a collection of educational models, mainly of wooden construction, which were built in that period by either German or Italian manufacturers (e.g., the Schröder Company of Darmstadt or other specialized companies, or even local craftsmen under direct supervision of Prof. Ovazza). They can be easily actuated to demonstrate their characteristic functionality, and were shown to the



**Fig. 3** Didactic models of elementary and complex mechanisms used in TTM lessons at the University of Palermo at the beginning of the 19th century, (Monastero and Genchi 2012). Courtesy of the Museum of Engines and Mechanisms

students during theoretical and practical lessons in the classrooms. All of them are now exhibited in a dedicated room of the Museum of Engines and Mechanisms at the University of Palermo (Monastero and Genchi 2012).

Similarly, Prof Ovazza was used to applying instruments in his research activity with equipment that he either acquired and adjusted or developed specifically for his testing. Figure 4 shows instruments that are stored in the Museum of Engines and Mechanisms that came from the laboratory that Ovazza organized for intense experimental activity, both for investigating phenomena and validating the functioning of designed devices.

Figure 5 shows an example page of a didactical treatise on Mechanics of Machinery (Ovazza 1901). The text and drawings were made personally by Elia Ovazza. The handwriting is quite clear and polished and the concepts are presented with an admirable clarity that is still valuable for modern teaching. (The same can be said about all of Prof. Ovazza's manuscripts.)



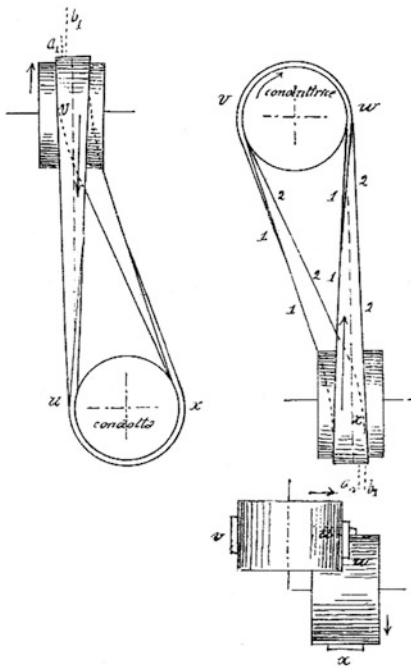
**Fig. 4** Instruments used in the experimental works of Elia Ovazza, as exhibited in Museum of Engines and Mechanisms, University of Palermo

Figure 6 shows an essential sketch of hyperboloid screws in which the geometric characteristics are emphasized for a clear explanation both of the design geometry and operation functionality.

Similarly, the clarity of explanation for teaching purposes is evident in Fig. 7 through which Prof. Ovazza explains both the theoretical thermodynamic diagram and real functioning diagram of a steam engine for his lectures on steam powered machines (Ovazza 1908). The purpose of the analysis is not only devoted to the proper action of a steam machine, but also gives hints for proper regulation and even design issues.

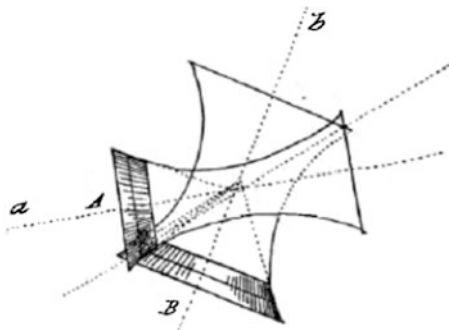
Figure 8 refers to lecture notes on the phenomena of impacts and explosions, the content of which includes both teaching parts and reports of recent results, both in experiences and new designs (Ovazza 1902). In particular, the sample page in Fig. 7 shows the description of a hammer machine with a double effect piston with a clear indication of the parts and their functioning.

Ovazza discussed specific studies and solutions in specific reports and short publications, like those mentioned above, not only so as to disseminate his results but mainly for the clear purpose of passing along a common Italian approach to developing machines and their backgrounds.



quindi s'immagina la cinghia di  
 vista in fibre longitudinali e fra  
 loro eguali, una di esse verrà ad  
 essere tanto più caricata quanto  
 più è vicina al bordo interno 1,2;  
 (ricordiamo che in dinamica dimo-  
 strasi che il carico è crescente logarit-  
 micamente coll'ampiezza dell'arco  
 abbracciato. Segue che la linea d'azio-  
 ne  $f$  della risultante delle tensioni  
 del cingolo non coincide con la linea  
 media del cingolo, ma è più vicina

**Fig. 5** A page from Lectures on Mechanics of Machinery by Elia Ovazza with special focus on Kinematics of belt transmissions (Ovazza 1901)



**Fig. 6** Modeling of skew gears in Lectures on Mechanics of Machinery by Elia Ovazza with special focus on Kinematics (Ovazza 1901)



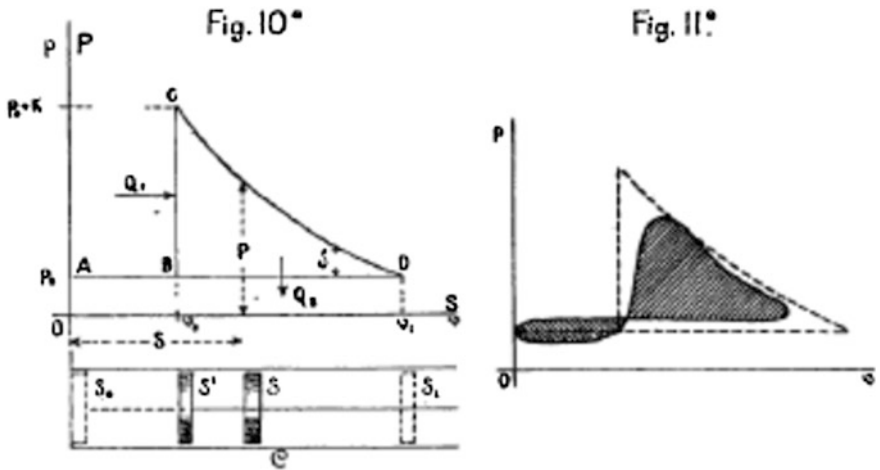


Fig. 7 Theoretical studies of steam machines in Lectures on Hydraulic and Thermal Machines by Elia Ovazza (Ovazza 1919)

## 5 A Survey of Ovazza’s Contributions

The scientific activity of Elia Ovazza was directed both towards educational purposes and technical interests, as per the mission that research in academic subsystems is aimed at producing well-formed new generations of engineers. Thus, Ovazza’s contributions were in teaching, and even his technical designs and research results were directed towards the aim of disseminating optimism throughout the realm of technical education, along with their inherent goal of solving open problems.

In particular, in Monastero and Genchi (2012), Ovazza studied the application of the theory of funicular polygons in the field of Kinematics by exploiting the analogy between the composition of the force vectors in Statics and the elementary rotation in Kinematics. This permitted him to solve, in an efficient and elegant way, the composition of 3D movements by means of an equilibrium approach.

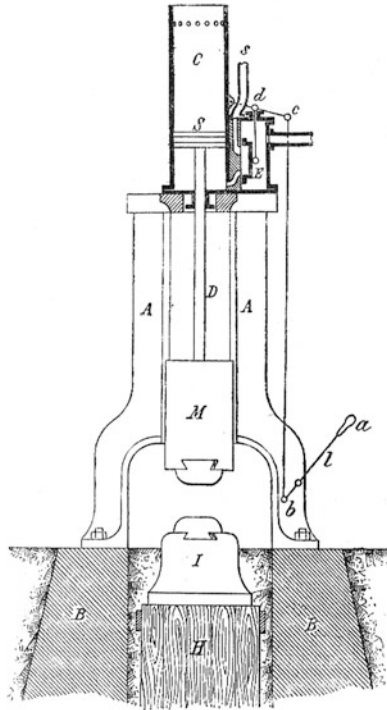
In the chapters on Kinematics in the treatise “Mechanics of Machinery” Ovazza (1901, 1907, 1908), several problems regarding the contact between rigid bodies are clearly presented and solved, as in the example in Fig. 9, from theoretical viewpoints, while applications are left to the readers. Specific attention is also addressed to design problems, as in the case of gears that were well understood as fundamental transmissions and a system for machine designs. An example of the general problems that Ovazza attached is shown in Fig. 6 for the skew gears.

Several other aspects and machine systems, including practical mechanisms and mechanical devices, are considered by Ovazza in his analyses through mathematical approaches that were given in graphical procedure for practical computations. Those procedures and their backgrounds can still be appreciated as useful means, not only for teaching the concepts behind machine design and their operation, but even as inspiration for modern computational algorithms.

— 32 —

sicchè il cassetto, come indica la figura, viene a mettere in comunicazione la camera inferiore del cilindro col tubo di scarica, ed il martello collo stantuffo cade liberamente sul pezzo che il fuciatore ha posato sopra l'incudine.

57. — La figura 9 rappresenta schematicamente il cilindro per maglio a doppio effetto.

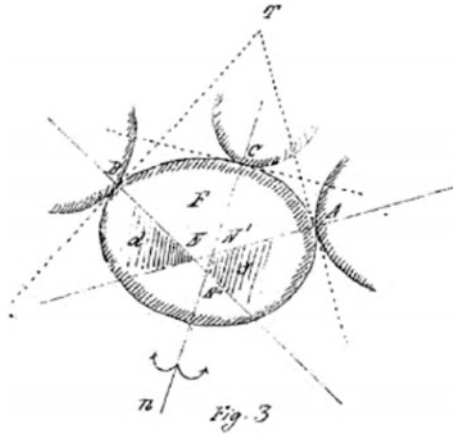


Lo specchio delle luci ha 3 condotti, uno centrale di scarica, gli altri per l'introduzione in una o nell'altra delle camere in cui lo stantuffo divide il cilindro.

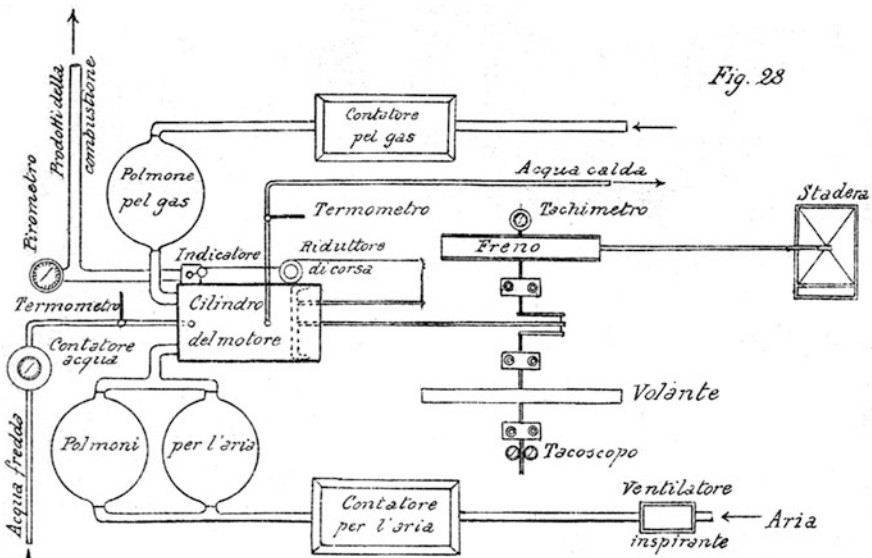
**Fig. 8** Title page and an inner page from *Lectures on Applied Dynamics* by Elia Ovazza with special focus on impacts and explosions (Ovazza 1902)

Elia Ovazza carried out a wide campaign of experimental tests on internal combustion engines (Ovazza 1905). For his testing activity, he also developed proper test-bed systems and testing procedures like the one shown in Fig. 10, which displays a remarkable amount of modernity in its approach to integration of assorted equipment from different engineering disciplines. Even the results, like those shown in Fig. 11, were of significant impact and can still nowadays be considered valuable for a characterization of engines.

His practice-oriented activity, both in teaching and research, can be appreciated in all his designs and the new designs in which remarkable evidence of such integration of teaching and research activities can be observed. Examples are shown



**Fig. 9** Analysis of multiple constraints in body frames in Lectures on Mechanics of Machinery by Elia Ovazza with special focus on Kinematics (Ovazza 1901)



**Fig. 10** Experimental setup for internal combustion engine tests in the Engine Laboratory (University of Palermo) at the beginning of the 19th century (Ovazza 1905)

in Figs. 12 and 13, which display novel designs for regulating valves and mechanical brakes, respectively. In particular, the designs for the regulating valves in Fig. 12 shows a novel concept of shaping the moving element or using a proper motion for the intercepting body. Figure 13 shows a new mechanical brake for

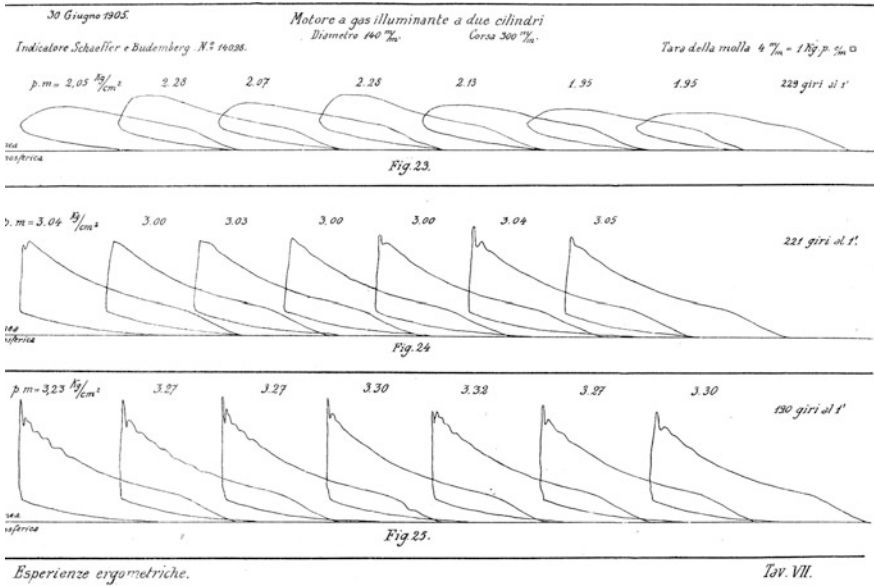


Fig. 11 In-cylinder pressure diagram from experimental tests on an internal combustion engine (Ovazza 1905)

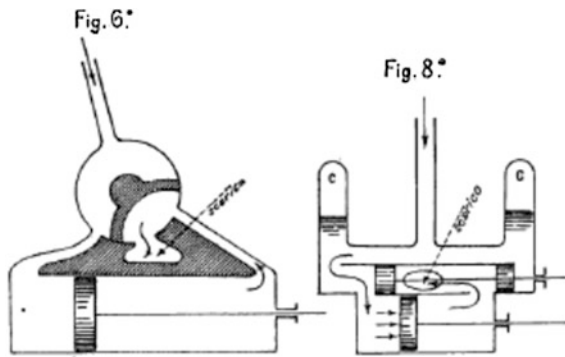
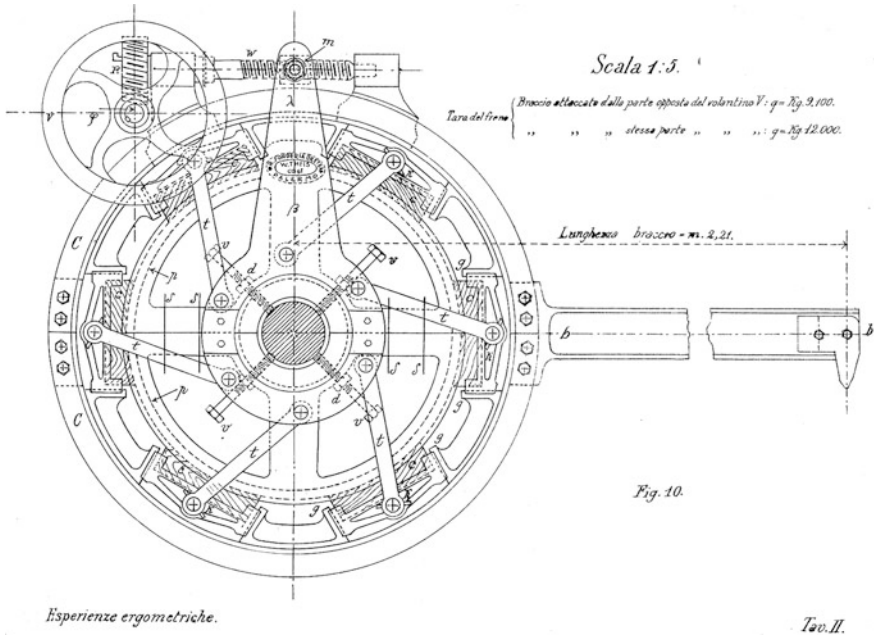


Fig. 12 Studies of new solutions for regulating valves in Lectures on Hydraulic and Thermal Machines by Elia Ovazza (Ovazza 1919)

testing engines by using a complex linkage-based system for efficient braking elements.

The mixture of teaching and design purposes in Ovazza’s work is even more evident in his writing on railway techniques (Ovazza 1924), a presentation organized in four volumes: Vol. 1: The vehicles and the railway; Vol. 2: Apparatus,



**Fig. 13** Brake for internal combustion engine test bench of the Engine Laboratory (University of Palermo) at the beginning of the 19th century (Ovazza 1905)

mechanisms and installation of railways; Vol. 3: Locomotives and railcar brakes; Vol. 4: Special railways.

This book, like some of his others, is still of current interest, and a few of them are still available for purchase as reprinted paperbacks.

## 6 Conclusions

This paper rediscovers the figure of Elia Ovazza as a very active academic with significant activity in teaching, research, design and technology transfer of expertise in TMM, whose legacy and contributions deserve renewed consideration for a full understanding of the evolution of TMM in Palermo and in the Italian subsystems.

## References

Ajovalasit A, Tschinke M (2006) Development of mechanical sciences in the University of Palermo. In: La Mantia FP (ed) Contributions for a History of Engineering School in Palermo. Fotograf, Palermo (in Italian)

- Angotti F, Pelosi G, Soldani S (2010) At the beginning of modern engineering: expertise and opportunities in Florence during XIX century. Firenze University Press, Firenze (in Italian)
- Benfratello G (2006) Historical profile of the Faculty of Engineering of Palermo. In: La Mantia FP (ed) Contributions for a History of Engineering School in Palermo. Fotograf, Palermo (in Italian)
- Boscovich R (1763) *Theoria philosophiae naturalis, Venetiae*
- Branca G (1629) *Le machine*, Roma
- Capocaccia AA (ed) (1977) *History of technique*. UTET, Torino (in Italian)
- Cardone V, La Mantia FP (2006) The history of engineering and engineering formation in Palermo e in Italia. CUES, Salerno (in Italian)
- Ceccarelli M (1998) Mechanism schemes in teaching: a historical overview. *ASME J Mech Des* 120:533–541
- Ceccarelli M (2000) Italian kinematic studies in XIXth century. In: Proceedings of IFToMM international symposium on history of machines and mechanisms HMM2000. Kluwer, Dordrecht, pp 197–206
- Ceccarelli M (2007) Giulio Mozzi (1730–1813). In: *Distinguished figures in mechanism and machine science: their contributions and legacies—Part 1*. Book series on history of machines and machine science, vol 1. Springer, Dordrecht, pp 279–293
- Ceccarelli M (2010) Francesco Masi (1852–1944). In: *Distinguished figures in mechanism and machine science: their contributions and legacies—Part 2*. Book series on history of machines and machine science, vol 7. Springer, Dordrecht, pp 141–162
- Ceccarelli M (2014a) Allievi Lorenzo (1856–1941). In: *Distinguished figures in mechanism and machine science—Part 3*. History of mechanism and machine science, vol 26, pp 1–17
- Ceccarelli M (2014b) Giuseppe Antonio Borgnis (1781–1863). In: *Distinguished figures in mechanism and machine science—Part 3*. History of mechanism and machine science, vol 26, pp 41–56
- Ceccarelli M (2014) A short history of mechanics of machinery in Italy. In: Proceedings of the fifth Italian conference on history of engineering. Ed Cuzzolin, Napoli, pp 87–102 (in Italian)
- Curti R, Grandi M (1998) *Learning a machine: industry and technical school in Bologna*. Ed. Compositori, Bologna (in Italian)
- Dameri A (2010) The Royal School of Engineering in Turin: teaching and experimental activity between XVIII and XIX centuries. In: Proceedings of the fifth Italian conference on history of engineering. Cuzzolin Ed., Napoli, pp 347–358 (in Italian)
- Della Pietra L (2010) Mechanics of machinery in Napoli. In: Proceedings of the fifth Italian conference on history of engineering. Cuzzolin Ed., Napoli, pp 713–634 (in Italian)
- Del Monte G (1577) *Mechanicorum liber*, Pesaro
- Dimarogonas AD (1903) The origins of the theory of machines and mechanisms. In: Erdman AG (ed) *Modern kinematics—developments in the last forty years*. Wiley, New York, pp 3–18
- Fang Y, Ceccarelli M (2013) Findings on Italian historical developments of machine technology in 19th century towards industrial revolution. In: Proceedings of the 11th IFToMM international symposium on science of mechanisms and machines (SYROM'13 Brasov). Springer, Dordrecht, pp 493–501
- Fang Y, Ceccarelli M (2015) Medium size companies of mechanical industry in North Italy during mid 19th Century (Chap. 11). In: *Discovers in the history mechanical engineering*. Springer, Dordercht
- Frisi P (1777) *Instituzioni di Meccanica, d'Idrostatica, d'Idrometria e dell'Architettura Statica, e Idraulica*, Galeazzi Regio Stampatore, Milano (in Italian)
- Galilei G (1600) *Le meccaniche*. In: Favaro A (ed) “Opere di Galileo”, Firenze, pp 1964–1966
- Grandi G (1739) *Instituzioni Meccaniche*, Firenze (in Italian)
- Hartenberg RS, Denavit J (1956) Men and machines ... an informal history, machine design, 3 May 1956, pp 75–82; 14 June 1956, pp 101–109; 12 July 1956, pp 84–93
- Mesini E, Mirri D (eds) (2012) *Science and technique in XVIII and XIX centuries*, CLUEB, Bologna (in Italian)

- Monastero R, Genchi G (2012) *Machines: energy and history—the museum system of Palermo University*. Plumelia, Palermo (in Italian)
- Ovazza E (1890) *The funicular polygon in kinematics*. Clausen Libraio, Torino (in Italian)
- Ovazza E (1899) *On bridges*. Royal School of Applications for Engineers in Napoli, Napoli (in Italian)
- Ovazza E (1901) *Mechanics of machinery—kinematics*. Royal School of Applications for Engineers in Palermo, Lit. Longo, Palermo (in Italian)
- Ovazza E (1902) *Shocks and explosions—lectures on applied dynamics*. S. Lattes & C. Librai Editori, Torino (in Italian)
- Ovazza E (1905) “*Esperienze Ergometriche*”, Regia Scuola d’Applicazione per Ingegneri ed Architetti in Palermo, Palermo (in Italian)
- Ovazza E (1907) *Mechanics of machinery—machines*. Royal School of Applications for Engineers in Palermo, Palermo (in Italian)
- Ovazza E (1908) *Mechanics of machinery—steam machines*. Royal School of Applications for Engineers in Palermo, Palermo (in Italian)
- Ovazza E (1919) *Lecture notes for the course on hydraulic and thermal machines*. Arti grafiche Cav. G. Castiglia, Palermo (in Italian)
- Ovazza E (1922) *Machine designs*. Royal School of Applications for Engineers in Napoli (in Italian)
- Ovazza E (1924) *Lessons on railways 1922–1924*. Avalle Ed., Turin (in Italian)
- Pugno GM (1959) *Storia del Politecnico di Torino*, Torino (in Italian)
- Rossi C, Ceccarelli M (2013) *Heavy industries in Southern Italy before the unification* (Chap. 10). In: *Discovers in the history mechanical engineering*. Springer, Dordercht
- Singer C et al (2012) *History of technology*. Boringhieri, Torino (Italian Edition)

# Academician K.V. Frolov at Bauman Moscow State Technical University

Olga Egorova and Gennady Timofeev

**Abstract** Konstantin Vasiljevich Frolov is considered to be one of the pioneers of vibration study in Russia. His contribution to the development of theoretical and applied mechanics is recognized worldwide. He established a new scientific branch, the biomechanics of a human being, and was the first to formulate the main problem of vibration isolation of a complex system: “Man-Machine-Environment”. Throughout the entirety of his activity, he contributed significantly to modern Mechanism and Machine Science (MMS) as an engineer, Director of the Institute for Machine Science (named after A.A. Blagonravov (IMASH RAN)), and Head of the “Theory of Mechanisms and Machines” (TMM) Chair at Bauman Moscow State Technical University.

## 1 Brief Biography

Konstantin Vasiljevich Frolov (Fig. 1) was born on July 22, 1932, in Kirov in the Kaluga region (Russian Federation) into a family of office employees. His mother, Alexandra Sergeevna Frolova, was a doctor and worked in X-ray offices at military and municipal hospitals. His father, Vasily Ivanovich Frolov, was arrested in 1937 and became a political prisoner. Later, he was rehabilitated and left the family to live in Kazakhstan (USSR).

K.V. Frolov was always open about the way his youth was affected by the terrifying period of World War II. Still, he was lucky and managed not only to survive but to obtain a good education. He attended the school intermittently, and

---

O. Egorova (✉) · G. Timofeev

Department of Theory of Mechanisms and Machines (TMM), National Research University, Bauman Moscow State Technical University (BMSTU), Baumanskaya Street 5, Moscow, Russia

e-mail: cuba2006@inbox.ru

G. Timofeev

e-mail: timga@bmstu.ru



**Fig. 1** Konstantin Vasiljevich Frolov



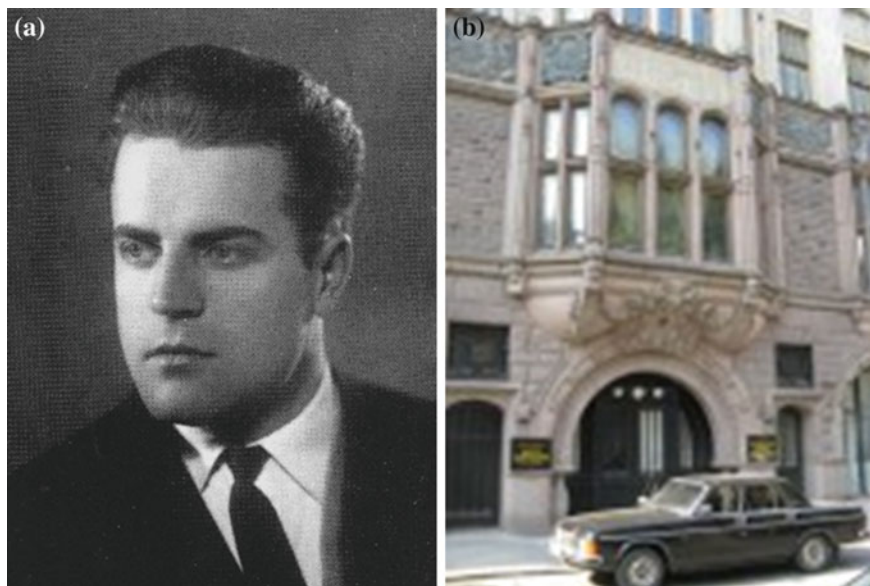
after the 7th grade (secondary school) entered the Lyudinovsk machine-building technical school, where, parallel to his studies, he actively worked in the laboratory of physics and electrical engineering, using his ham radio skills.

As a young boy, Konstantin dreamed of being a military pilot, but life had very different opportunities and fortunes in mind for him. Thus, in 1956, Frolov graduated with honors from Bryansk University of Transport Machinery (Russia), with a specialty in “Turbine construction”, and started working as an engineer at the Leningrad Metal Plant (LMZ), one of the largest power engineering enterprises in the Soviet Union at that time. There, he began his activity in the design bureau for steam and gas turbines. Very soon, in 1957, the young engineer began work at a new laboratory, called the “Vibration Study of Steam and Gas Turbines”, which was founded especially for the development of new methods of vibration testing of the turbines produced by LMZ.

Konstantin Frolov proved himself to be a skilled researcher, capable of experimental work. This was already evident from his first scientific publication, “Non-contact strain measurement”, in the Soviet scientific magazine “Energomachinostroenie”, 1957, No. 12. The article was devoted to the modern methods of vibration testing of steam and gas turbines compared with the latest achievements in the field of experimental researches obtained by domestic and foreign laboratories.

## 2 A Postgraduate Student

In autumn 1958, Konstantin Frolov (Fig. 2a) entered a Ph.D. program at the Institute for Machine Science (IMASH RAN, <http://eng.imash.ru>) in Moscow, now named after A.A. Blagonravov (Fig. 2b), joining the Institute’s staff. The famous Soviet scientist, Professor Victor Olimpanovich Kononenko, was appointed to be his thesis tutor. From that time on, Konstantin Vasiljevich would be connected with the Institute in perpetuity (1958–2007).



**Fig. 2** a Konstantin Frolov in the 1960s. b IMASH main building

Three years (1958–1961) as a young post-graduate student were devoted to interesting and highly significant research—the study of the influence of energy source properties on the stationary and non-stationary vibration of mechanical systems. The problem was that the increase in power and speed of modern machines while reducing the weight required careful dynamic research, including the vibration study.

In 1962, Frolov successfully defended his first thesis with the theme “Influence of energy source properties on vibration of autonomous systems”. In his thesis, the problem of the stability of various modes for the usual nonlinear, parametrical, and self-oscillatory systems was studied, as well as mathematically showing the link between the nonlinear system parameters and the energy source characteristics. In parallel with his postgraduate study of 1960, Konstantin Frolov attacked the problem of resonance states of solid bodies with nonlinear elastic links. As a result, the observed dependence of resonance states on an energy source was shown and proved through mathematical methods, as well as some new objective laws reflecting the influence of energy sources on the vibration of solid bodies being discovered and examined.

The young scientist’s success was noticed, and in 1964, Frolov was given the title of senior research assistant. Moreover, he was appointed to be the chief of a new laboratory, where he managed to combine his theoretical work, scientific publications and management duties.

**Fig. 3** Konstantin Vasiljevich Frolov in the late 1970s



In October 1975 (Fig. 3), after the death of academician A.A. Blagonravov, Frolov took his place as Director of IMASH RAN. From this point on, all the way up to his tragic death, he served as Head of the Institute, contributing much to its development and prosperity.

From K. Frolov's personal memoirs:

Here (IMASH RAN) I have found a way from being a post-graduate student to the academician and Director of the Institute. IMASH RAN became my life, my daily care, my pleasure, and sometimes my pain, my disappointment... I am happy that within more than 30 years... I am heading this wonderful collective of remarkable people, outstanding scientists, and employees of Institute for Machine Science of Russian Academy of Sciences.

### 3 Main Scientific Works

Having started his scientific activity with research on the general problems of TMM, durability and reliability of machines, and the theory of oscillation, Frolov would concentrate thereafter on the development of vibration technology and vibration isolation of a human being.

The list of scientific works by Konstantin Vasiljevich Frolov includes more than 500 titles. His series of works on machine dynamics were honored with the Gold Stodola Medal.

The most interesting results of Frolov's research works were published in fundamental monographs, textbooks and books:

“Applied Theory of Vibration Isolation Systems” (1989)

“Theory of vibration technics and technology” (1981)

“Scientific foundations of engineering progress” (1982)

“Membrane Vibration in a liquid” (1983)

“Methods of Machine Development and Modern Problems on Mechanical Engineering” (1984a)

“Vibration is a friend or enemy?” (1984b)

“Interaction of nonlinear oscillatory systems with power sources” (1985)

“Vibration Technology: Theory and Practice” (1991a, b)

“Theory of Mechanisms and Mechanics of Machines” (2002)

“Selecta. Vibration Technics” (2007)

From 1978 to 1981, he participated in a six-volume scientific edition titled “Vibrations in Engineering”, issued by the publishing house “Machinostroenie”, Moscow, acting as scientific editor for two volumes of this edition. His fundamental work “Science in strategy development” (1991), based on the results of his many-sided creative activity, should also be mentioned, as well as the Encyclopedias “Machine-building” and “Security of Russia”, for which he was the editor.

## 4 Teaching Activity

For more than 45 years, Konstantin Vasiljevich Frolov combined his research with teaching, and his contribution to the education of young scientists and engineers was equally remarkable. He was an excellent teacher, whose rich technical and scientific culture enabled him to offer interesting courses in the sphere of machine mechanics, machine parts, and dynamics. His lectures were always full of the latest information regarding achievements in international science and technology. He continued the Russian traditions and skillfully organized the educational process, promoting the introduction of modern methods of teaching.

From 1961 to 1976, he worked at the Moscow Technology Institute of Light Industry, and in 1973, he was elected their Department Chairman of “Theoretical Mechanics and Theory of Mechanisms and Machines”. He wrote a number of lecture courses, methodical study guides, and a new set of laboratory operation manuals.

As the Chairman, he insisted that each professor-lecturer should engage in very active scientific researches together with the students. In recognition of his overwhelming activity, Frolov was conferred, in 1971, with the academic status of Professor in the field of Mechanism and Machine Science.

In 1978, Konstantin Vasiljevich headed a Chair of “Theory of Mechanisms” (TM) at Bauman Moscow State Technical University (BMSTU, [www.bmstu.ru](http://www.bmstu.ru)) (Fig. 4), a position he maintained up to his death in 2007.



**Fig. 4** Main building of Bauman Moscow State Technical University

## **5 Bauman Moscow State Technical University**

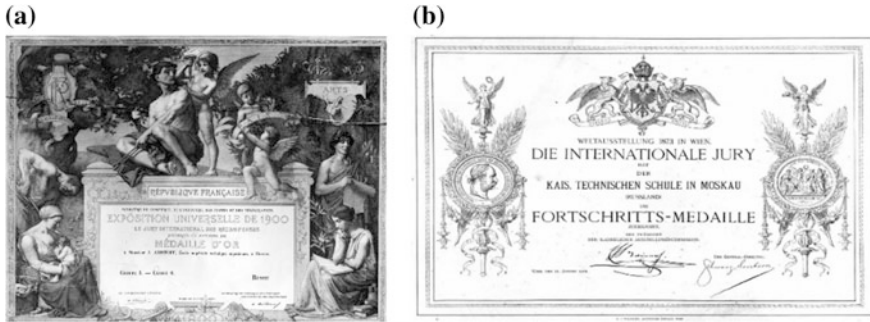
### ***5.1 Brief Historical Overview***

BMSTU was founded on July 1st, 1830, when the Emperor Nicholas I. of Russia (1796–1855), who is famous for having spread education throughout the Empire at all levels, approved the “Statute of Moscow Craft School”. The new school was founded for the training of young people in various crafts, as well as the fundamental sciences.

By 1868, the educational system implemented had proven so beneficial that MCS was reorganized into the Imperial Moscow Technical School (IMTS). The main purpose of IMTS was “to educate construction engineers, mechanical engineers and industrial technologists”.

IMTS’s educational system received recognition from all over the world. The “Russian method” became especially well-known after the Vienna World Exhibition (1873) where it was awarded the Big Gold Medal (Fig. 5b). IMTS was recognized as the best engineering educational institution in Russia and it joined the ranks of the world’s leading polytechnic schools. Soon after its first success, the famous “Russian method” had resulted in several 1st grade prizes at industrial exhibitions in Philadelphia (1876) and Paris (1900) (Fig. 5a).

After the triumph in the USA at the Philadelphia Centennial Exhibition, the then-President of the Massachusetts Institute of Technology (MIT), John Daniel Runkle (1870–1878), who was given a collection of Russian models for the training and laboratory practice of students, wrote to the director of IMTS, Professor Victor Karlovich Della-Vos:



**Fig. 5** a Paris, 1900; b Vienna, 1873

It's clear that engineering education in Russia is organized with great success...We're going to implement no other but this system here in the United States.

Runkle became aware of the “Russian method” because he was greatly impressed by the combination of theoretical and practical learning. Manual training was introduced into the institute curriculum largely at his insistence. In 1876, in Boston, John Runkle published a small brochure in English titled “The Russian system of shop-work instruction for Engineers and Machinists”, and the “Russian method” was integrated into the educational system of MIT.

The approach based on the “Russian method” was also taken up by Calvin Woodward of Washington University. This combination of tool and job analysis provided a basis for what would eventually become Taylorism.

A lot of outstanding scientists worked at IMTS: Dmitry Mendeleev, Nikolay Zhukovsky, Pafnuty Chebyshev, Sergey Chaplygin, A. Yerшов, Dmitry Sovetkin, Alexander Gavrilenko, etc.

During the Soviet period, IMTS was renamed the Bauman Moscow Higher Technical School (MHTS), named after N.E. Bauman. It continued teaching engineers for the machine tool industry and mechanical engineering as well. In 1938, new military departments were founded, and later, in 1948, a rocket department began work. Many famous scientists and engineers graduated from MHTS: aircraft and rocket designers Andrey Tupolev and Sergey Korolev; Nicholay Dollezhal, a key figure in the Soviet atomic bomb project and chief designer of the Soviet nuclear reactors; metallurgist and corresponding member Alexander Tselikov; cosmonauts; chief designers of plants and factories; etc.

Later, it was renamed the Bauman Moscow State Technical University (BMSTU). Throughout its long history, BMSTU has had a special responsibility for the development of national science and education, particularly in the field of engineering and technology. Today, Bauman Moscow State Technical University (Fig. 4) is one among 27 National Technological Universities in Russia and, as always, it is ranked first among Russian engineering educational institutions.

## 5.2 *Konstantin Vasiljevich Frolov at Bauman University*

Konstantin Vasiljevich Frolov started his career at Bauman Moscow State Technical University in 1978. He was one of the first to understand that no higher educational establishment or secondary technical school could give its graduates all the knowledge and skills needed to function efficiently at work. He voted for reforming the system of higher education so that it could make the institutions more flexible in responding to the needs of scientific and technological progress.

Frolov promoted the solution to this problem as being teaching the future researchers and engineers how to work independently from their first day at school, when the thirst for new knowledge and desire for constant study should come naturally to a present-day specialist. This was a pivot in the developing concept of uninterrupted learning. His words that “everyone must study and study constantly” are as relevant as ever, perhaps even more so now than in the last century.

Having received an excellent education, Frolov constantly aimed to address problems of training and effective application of the engineering staff. He promoted the Russian method of teaching born at BMSTU, which combined theoretical studies and engineering practice.

He put his enormous gifts to work giving life to all of his interesting ideas and improving the educational system. His dream was to organize a learning process in accordance with the current and future needs of industry, to train engineers who would be able to create competitive products, and to provide Russia with well-trained specialists who would be able to work at very high levels in enterprises, factories and plants.

Anyone who ever dealt with Konstantin Frolov recognized his unusually open mind. Endowed with a prodigious memory and remarkable work ethic, he fully engaged himself in guiding younger colleagues and subordinates, conducting doctoral theses, lecturing and even taking part in laboratory practice.

Frolov managed to equip the Bauman university lab with working models of industrial robots and to embed into the learning process a new course, “Manipulation robots”. He was also the editor of the original manual for higher technical schools and colleges, “Mechanics of industrial robots” (Frolov and Vorobiev 1988–1989) (Fig. 6), which was published in Moscow by the “Vicshaya Shkola” publishing house. Even today, in the 21st century, it can be used as a handbook for designers and experts in the field of industrial robotics.

Konstantin Vasiljevich appreciated not only the analytical and experimental, but also the organizational skills of his colleagues and students. He thought that such qualities as business acumen and the ability to understand people were crucial for leaders in modern science. He tried to push people with these talents and move them up the career ladder. He provided an “open door” policy for people capable of thinking creatively. Not coincidentally, more than thirty of his former post-graduate students became doctors of science and professors, and some of them later became corresponding members and academicians. The authors of this paper were also among those young students and postgraduates who, under his tutelage, managed to



Fig. 6 “Mechanics of industrial robots”, 1988–1989 (Frolov and Vorobiev)

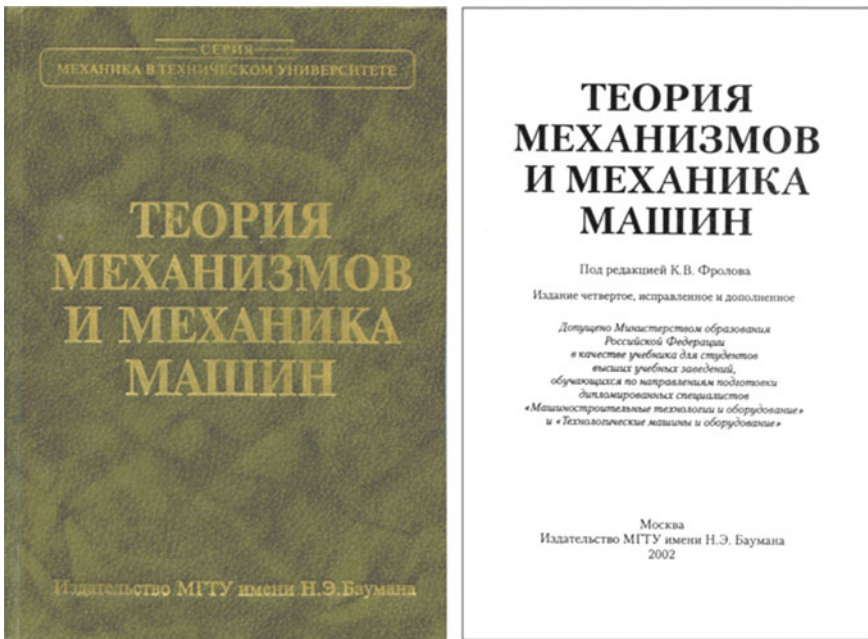


Fig. 7 “Theory of Mechanisms and Mechanics of Machines” textbook

graduate from the university, enter the postgraduate program and gain a degree of Doctor of Science.

His textbook (Fig. 7) “Theory of Mechanisms and Mechanics of Machines”, based on a new concept for teaching the “Theory of Mechanisms” course, has been published in four editions by BMSTU and is invaluable in helping students to learn TMM.



Frolov contributed much to the prosperity of Bauman University, being a “Board of Studies” member and a “Dissertation Council” member of the University.

## 6 History of Mechanism and Machine Science

Academician Frolov (Fig. 8) gave much of his attention to the History of Mechanism and Machine Science, as well as to scientific heritage in general and the role of prominent domestic and foreign scientists in the formation of modern scientific knowledge. He used to supplement his lectures with brief biographies of Russian scientists and their inventions, underlining their role in the success of Russian (Soviet) science. His book “Outstanding Soviet Scientists: Anatoly Arkadjevich Blagonravov”, written in cooperation with Arseny Arkadjevich Parhomenko and Mikhail Konstantinovich Uskov, was translated into English and enjoyed successful worldwide circulation.

Frolov dedicated a number of interesting historical lectures and articles to outstanding scientists: Michail Vasiljevich Lomonosov, Ivan Ivanovich Artobolevski, Victor Olimpanovich Kononenko, Leonardo da Vinci and Isaac Newton, in particular. His publication “Newton and Modern Mechanics” (Frolov 1988), devoted to the great English scientist, proves that mankind is obliged to Newton for ushering in a new epoch in the natural sciences: physics, astronomy, mathematics, and engineering, on the basis of facts that, for a period of more than 300 years after the initial publication of “Beginnings...”, appeared to be only insignificant amendments to Newton’s theories.

**Fig. 8** Academician  
Konstantin Vasiljevich Frolov



With this publication, Frolov demonstrated the important and instructive role of the History of Science and Technology. Firstly, we learn to appreciate what we possess today; secondly, the historical approach allows us to estimate the practical value of science; and lastly, the History of Science makes up for “short-sightedness” in estimates of discoveries already made and theories already developed. Newton’s scientific activity represents one of the brightest and most decisive stages in the evolution of human thought. His works marked a quantum leap in a long history of quantitative accumulation of knowledge of Nature. His theories were a huge contribution to the development of science and modern civilization as a whole.

## 7 Folov’s Awards

For the great services he performed for his Motherland, academician Konstantin Vasiljevich Frolov was given the title of Hero of Socialist Labour, awarded two Lenin Prizes (Gold Star), and State Prize. Among foreign prizes and awards, he earned the Aurel Stodola Gold Medal of the Slovak Academy of Science, the “Silver Medal” of the Czech Academy of Science “For services to science and humanity”, and the “Mikhail Pupin Gold Medal” (Yugoslavia).

Unfortunately, after serious illness, on November 18th, 2007, in Moscow, Academician Konstantin Vasiljevich Frolov passed away at only 75 years old. He had a rich life as a Man and a professional, dedicating himself to Mechanism and Machine Science, and the Applied Theory of Vibration Isolation Systems in particular. He was a very optimistic and goal-oriented person.

From K. Frolov’s personal memoirs:

The constant strong belief in good deeds and their fulfilment is the main source of optimism that always inspires me in finding the solutions to difficult problems.

## 8 Conclusions

Academician Konstantin Vasiljevich Frolov can be considered to be one of the great scientists of modern MMS. Through his extensive scientific activity, he was influential in numerous topics and contributed to the worldwide recognition of the Russian engineering school. His role in the development of mechanical engineering, the applied theory of mechanic vibrations and vibration studies, biomechanics (Man-Machine-Environment Systems), vibration isolation and vibroacoustic diagnostics, nuclear reactor strength, and safety (natural and technogenic) problems is inestimable. He contributed considerably to the development of the Russian method of engineering education promoted at Bauman Moscow State Technical University.

**Acknowledgments** The authors wish to thank the employees of the IMASH Library and of the BMSTU Library.

## References

- Achievements and Problems of Machine Science (2006). Devoted to the 70th anniversary of academician Konstantin Vasiljevich Frolov. Znanie, Moscow
- Achievements and Problems of Modern Theory of Machines (1984). VI World congress on the theory of machines and mechanisms, vol I, New York etc., pp 5–17
- Egorova OV (2012) History of engineering of Russian and Soviet scientists. *Terraspaces Sci Eng* 5 (2):147–153
- Egorova OV (2014) Konstantin Vasiljevich Frolov (1932–2007), distinguished people in mechanism and machine science, part 3. Springer, Berlin
- Egorova OV, Timofeev GA (2012) Konstantin Frolov continuing the Soviet School Traditions on MMS, history of mechanism and machine science, vol 15. Springer, Berlin
- Egorova OV, Tarabarin VB, Timofeev GA (2013) On the history of formation of the Russian School of Applied Mechanics, BMSTU. In: *Proceedings of Higher Educational Institutions, Machine Building*, vol 2, Moscow, pp 76–83
- Frolov KV (1970) Dependence on position of the dynamic characteristics of human operator subjected to vibration. *Dynamic response of biomechanical systems*, ASME
- Frolov KV (ed) (1978) *Vibrations in technics*, Reference book, vol 1–6. *Machinostroenie*, Moscow, 1978–1981, 1995, 1999
- Frolov KV (1984a) *Methods of machine development and problems of mechanical engineering*. *Machinostroenie*, Moscow
- Frolov KV (1984b) *Vibration is a friend or enemy?* Nauka, Moscow
- Frolov KV (1988) Newton and modern mechanics. In: *Nauka in USSR*, No. 6. pp 58–65
- Frolov KV (1998) Engineering science on the eve of the twenty-first century. In: *Engineering and reliability of machine problems*, No. 5, pp 3–12
- Frolov KV (2001) Documents for scientists bibliographies, RAS, issue 4. Nauka, Moscow, pp 10–39
- Frolov KV (ed) (2002) *Theory of mechanisms and mechanics of machines*. BMSTU, Moscow
- Frolov KV (2007) *Selecta*. In: *Vibration technics*, vol 1–2. Nauka, Moscow
- Frolov KV, Alifov AA (1985) *Interaction of nonlinear oscillatory systems with energy sources*. Nauka, Moscow
- Frolov KV, Alifov AA (1990) *Interaction of nonlinear oscillatory systems with energy sources*. Hemisphere Publishing Corporation, New York
- Frolov KV, Antonov VN (1983) *Membrane vibration in a liquid*. Nauka, Moscow
- Frolov KV, Furman FA (1980) *Applied theory of vibration protection systems*. *Machinostroenie*, Moscow
- Frolov KV, Furman FA (1989) *Applied theory of vibration isolation systems*. Hemisphere Publishing Corporation, New York
- Frolov KV, Gluharev KK (1971) *The classification and peculiarities of oscillatory systems with limited excitation*, Bratislava
- Frolov KV, Goncharevich IF (1981) *Theory of vibration technics and technology*. Nauka, Moscow
- Frolov KV, Goncharevich IF (1991a) *Vibration technology: theory and practice*. Mir, Moscow
- Frolov KV, Goncharevich IF (1991b) *Vibration technology. Theory and practice*. CRC Press, Boca Raton
- Frolov KV, Makhutov NA (eds) (1998–2007) *Security of Russia. Legal, social-economic and science and technology problems*, 35 vols. Znanie, Moscow
- Frolov KV, Mirkin AS (1997) *Vibrations, vibrational process and environment*. Znanie, Moscow

- Frolov KV, Vorobiev EI (1988–1989) Mechanics of industrial robots: manual for institutes, vol 3. Vicshaya Shkola, Moscow
- Frolov KV, Parkhomenko AA, Uskov MK (1982) Anatoly Arkadjevich Blagonravov. Nauka, Moscow
- Frolov KV, Parkhomenko AA, Uskov MK (1987) Machine science as a base of mechanical engineering. Nauka, Moscow
- Frolov KV, Dimentberg MF, Menyailov AI (1991a) Vibroacoustic diagnostics for machines and structures. Research Studies Press LTD. Taunton. Wiley, NewYork
- Frolov KV, Izrailev YuL, Makhutov NA (1991b) Thermal stresses and strength of turbines: calculation and design. Hemisphere Publishing Corporation, New York
- Soviets seen at crossroads over education: about KV Frolov, vol 10 (1998). The Boston Globe, Boston
- Timofeev GA, Frolov KV (1932–2007), Vestnik of MGTU named after Bauman, vol 4. MGTU, Moscow, pp 121–130. [http://en.wikipedia.org/wiki/John\\_Daniel\\_Runkle](http://en.wikipedia.org/wiki/John_Daniel_Runkle)

**Part II**  
**History of Industrial Installations**

# Historical Watermills. Architectural, Mechanical and Hydraulic Heritage

Mario Centofanti, Stefano Brusaporci and Vittorio Lucchese

**Abstract** Historic watermills are studied as a complex heritage given by the synergy of buildings, hydraulic works and mechanical elements. They are the result of processes of modification and stratification that have occurred over the centuries, interrelated to landscape and human history. In particular, the paper focuses on historic watermills in the territory of Teramo (Italy), aiming to understand the history, culture, economy, and technological evolution of the territory. Moreover although these mills are local phenomena, the solutions—in particular, those derived through an accurate, wise and pragmatic use of natural resources—can reveal traditional practices no longer known, recurrent in similar environmental contexts, that can explain common solutions of wider historical and territorial diffusion.

## 1 Introduction

In the territory of Teramo (Abruzzo Region—Italy), there are many mills, realized in the Middle Ages, used and transformed up until the twentieth century (Demangeot 1965; Feliciani and Pellegrini 1985; Pellegrini 1985; Franchi Dell’Orto 1991; Maestri et al. 1992; Costantini and Felice 1993; Cooperativa Arkè 1998; Ciampani 1999; Burri and Centofanti 2000; Liberato and Di Aldobrando 2001; Pellegrini 2003; Aceto 2006; Castellucci 2011; SIGEA 2011). Mills are specialized buildings, integrated into the rural and urban territorial settlements. They are an

---

M. Centofanti (✉) · S. Brusaporci · V. Lucchese  
DICEAA, Department of Engineering Faculty, University of L’Aquila,  
via G. Gronchi 18, 67100 L’Aquila, AQ, Italy  
e-mail: mario.centofanti@univaq.it

S. Brusaporci  
e-mail: stefano.brusaporci@univaq.it

V. Lucchese  
e-mail: vittoriolucchese@gmail.com

anthropic component of the landscape, denoting the use, transformation and modification of the territory, economy, technology and culture over the centuries. Mills are complex symbols of cultural heritage, a synthesis of architectural, hydraulic and mechanical components (Pirenne 1937; Grand and Delatouche 1950; Singer et al. 1958; van Slicher 1963; Duby 1968; Cortese 1997; Cigola and Ceccarelli 2011).

The paper presents the last results of a research on historical watermills carried on over several years by a research group at the Department of Civil, Environmental and Building Engineering—Architecture of L’Aquila University (Continenza and Brusaporci 2012; Di Donato 2012; Centofanti et al. 2013, 2014).

Centofanti wrote the first and third sections; Brusaporci the second, fourth, and seventh ones; and Lucchese the fifth and the sixth ones.

## **2 Watermills, the Shape of a Landscape, and the Complexity of Heritage**

When Tielden wrote his essay on heritage in 1957, he focused it on the concept of “Interpretation”. The paper—an historical reference in the field of cultural heritage preservation—deals with heritages universally recognized as such: National Parks, Objects in Museums, Historic Places. Therefore, the issue of interpretation first refers to the theme of communication.

The concept of heritage has evolved over the years, broadening the focus from the monument to its context, resulting in the entire historicized environment. At last, we have come to a more complex concept, with the integration of material and intangible heritage (Unesco Convention for the Safeguarding of Intangible Cultural Heritage, Paris 2003).

In parallel, the concept of landscape has also evolved, moving from the meaning of “nature” and “panorama” towards a contemporary integrated idea, through the combination of historical and aesthetic considerations with environmental and ecological ones. The European Landscape Convention (Florence, 2000) says: ““Landscape” means an area, as perceived by people, whose character is the result of the action and interaction of natural and/or human factors”. Therefore, the landscape configures as an indissoluble binomial of nature/man, the result of historical processes of transformation and modification, in which cultures occurred over time, human activities and natural contexts contributing to the overall environmental fabric.

Consequently, also referring to the characteristics of the territory under study, it’s very difficult—if not impossible—to draw a clear line between what is worthless and what is not, i.e., “monuments” versus “non-monuments”, because there are different critical value “levels”. The historic watermills are not, per se, subject to the laws of protection, but their study allows us to highlight their importance, because they compose the landscape, and they “reflect” the history: mills result from historical and cultural events that have occurred in past ages, and take part in defining territorial, social and economic mutations.

In addition, the mills not only have a diachronic stratification (for example, wooden or cast iron mechanisms), but they also modify in a diatopic way: although the territory in question is not wide, building types, mechanisms and hydraulic works take on different features depending on the characteristics of the waterways and the environment: in fact, mills' typologies, technologies and materials change according to the succession of landscapes along the river. At first, the river has a torrential regimen, by crossing an irregular mountain area, with marl limestone soils; then, the landscape is characterized by high hills, and the course of the river becomes more regular, less steep, richer in water. Mills have horizontal water wheels: they allow for making the most of the scarce and fast regimes, and of the low depth of the watercourse. Finally, the river goes down to the sea on alluvial soils, flowing in a wide and sinuous bed. And there are not only horizontal water wheels, but also vertical ones, in particular, for copper processing.

Recalling the arguments of Brandi in his "Theory of Restoration" (Brandi et al. 1963) with regard to the concept of "the whole" of a work of art, it is evident that the mills are cultural heritage composed of different components, each one modified and stratified: but architectural, mechanical and hydraulic artefacts together constitute the testimonial value of the actual mill. In this sense, each mill is made up of an inseparable unity of artefacts.

In conclusion, the concept of "Interpretation" comes back once again, because it retains a great validity if it is intended as the need to study, comprehend and communicate—to the scientific community but also to politicians and citizens—the historical and cultural, tangible and intangible values of mills, i.e. complex cultural heritages (Fig. 1).

### 3 Mill's Surveying

The research has been developed in stages. The first step involved the bibliographical and documental analysis, the study of current and historical cartography and toponyms, in order to identify sites where mills stood that no longer exist or where mills still stand in a state of ruin.

The second phase was the collection of data, in particular, through the design and use of analysis cards (Figs. 2 and 3).

Specifically, the cards have been structured according to the following fields:

- Identification and general data of the building: name, property, location, elevation above sea level; territorial mapping framework (1:25,000, orthophotos scale 10,000); accessibility; context description; current use.
- Survey of hydraulic works.
- Survey of the building: number of floors, height and area of the plans; age of first construction, primary changes, age of eventual abandonment; photographic survey; construction techniques (walls, floors, roofs, etc.); documental data, historical critical analysis.



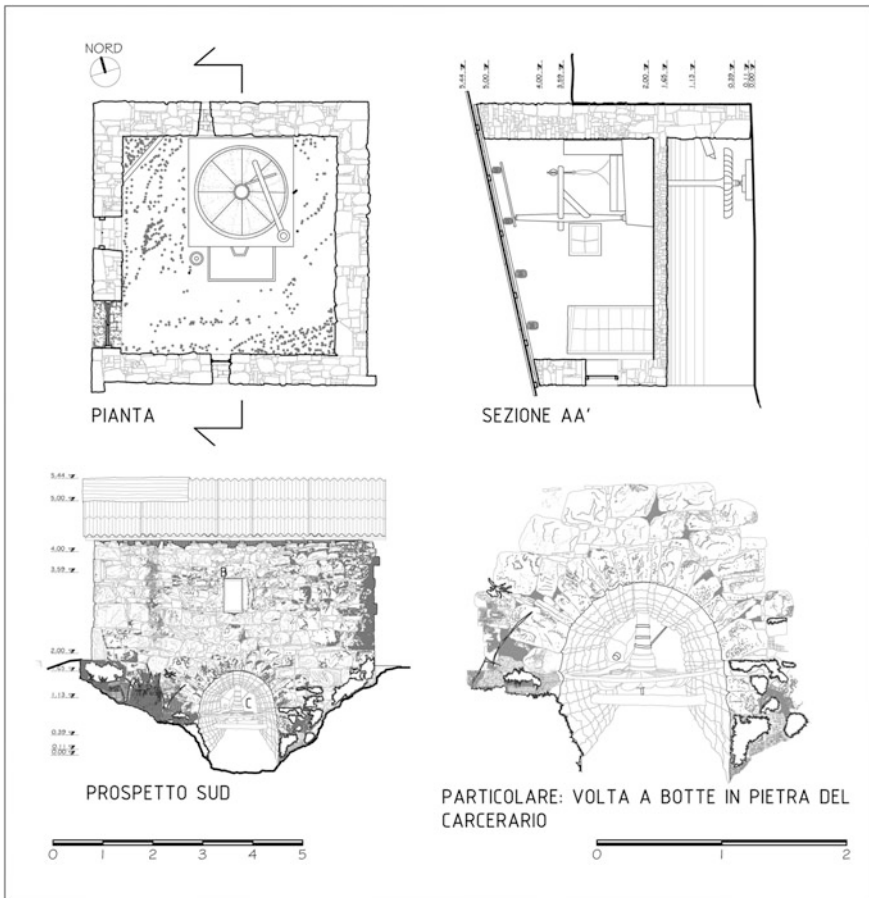


Fig. 1 The river, buildings and mechanisms in mountain, hill and coastal landscapes



Fig. 2 The mills in the Tordino river's valley





**Fig. 4** Architectural surveying of Fioli mill

by others for storage on the lower level and for residential and production use on the upper level. This shows how mills are linked to a sedentary economy.

The residential function and the more widespread use of brick lead to an enrichment of the architectural language, with the appearance of brick cornices, pilasters, and vaults. It is not uncommon to see the presence of different mills: the Villa Tordinia mill has horizontal wheels for grinding and a vertical wheel for copper processing.

These mechanisms were realized later and were witnesses to the process of the first industrialization between the 19th and 20th centuries.

Mills in hilly and coastal areas were used in the last century; therefore, they are largely in good condition and show greater phenomena of modification, including of the mechanisms, which are sometimes modernized with metallic elements. Mills in mountain areas, contrastingly, are mostly in a state of ruin or severely degraded (Fig. 4).

## 5 The Hydraulic Works

A mill is based on the use of water as an energy source, through water wheels. None of the mills on the Tordino are located directly on the river, so the functioning is made possible by hydraulic works necessary for the derivation of water from the river.

Intake works, no longer in existence in most cases, are made with stones, wood or soil sills or weirs. So, a part of the water stream, slightly elevated, flows through a diversion channel, called a “gora” (locally, a “forma” or “formale”) of variable length up to a few kilometers. Generally, at the beginning of the channel, a grid is placed to keep out solid sediment along with a spillway that allows you to adjust the inflow, returning the excesses to the river. At least twice a year, in early spring and early autumn, maintenance was done on the channel (Fig. 5).

In the vicinity of the mill, the channel widens into a storage reservoir, so as to regulate the flow rate. Then, from the reservoir, a second channel carries the water to the hydraulic wheel; in the last stretch, it narrows into a funnel shape to minimize the head losses and to maximize the pressure on the paddles of the wheel. Downstream of the mill, the water runs through the restitution channel and comes back into the river.

In most cases, the storage reservoir, due to its small size, simply needs to regulate the water flow and not to accumulate water resources for dry periods.

The hydraulic works allow for significant heads, according to the mountain sites with steep slopes. For example, in the Fioli mill, the head is about 13 m. A rapid



**Fig. 5** Hydraulic works of the Fioli mill: the diversion channel and the storage reservoir



**Fig. 6** Soil diversion channel photos. On the *right*, the last stretch of the channel, just upstream of the mill

assessment of the generated power can be provided by applying the well-known formula  $P = g Q H \mu$ , where  $g$  = gravity acceleration,  $Q$  = pipe water delivery,  $H$  = hydraulic head (m), and  $\mu$  = machine efficiency.

The power generated is highly dependent on the machine efficiency  $\mu$ , which, in conventional plants, is very low Reynolds (1984, p. 110), estimates an efficiency of no more than 5–15 %, Makkai (1981, p. 169), between 10 and 20 %. Foresti et al. (1984, p. 75), consider a value between 30 and 40 %, probably referring to mechanisms with many parts made of iron, which, in many parts of Italy in the 19th and 20th centuries, have replaced the similar wood. Using the values derived from the mills survey, estimating, for example, a water flow rate  $Q = 40$  l/s and an average efficiency  $\mu = 0.20$ , the power is  $P \approx 1$  kW (Fig. 6).

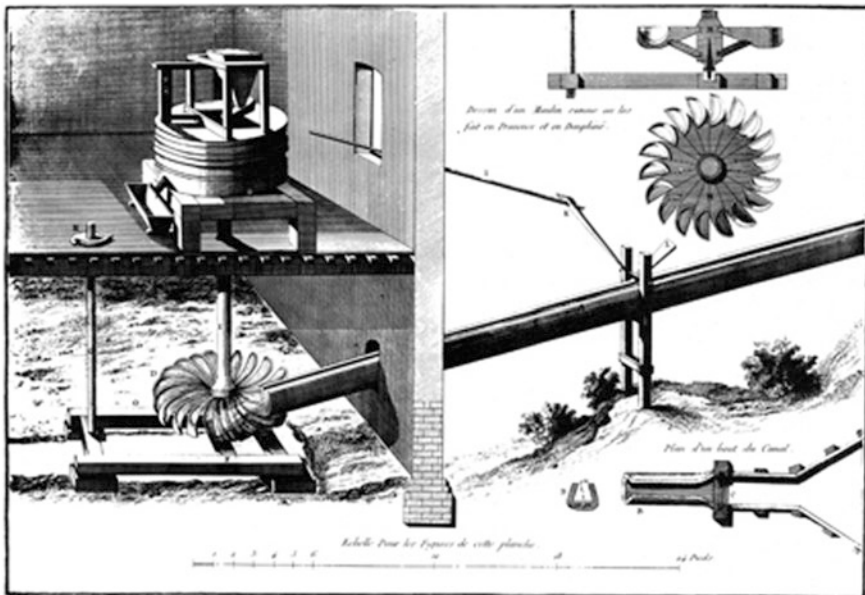
A specific case study is offered by the mills of Comignano, Servillo and Cortino, which use the waters of a tributary of the Tordino, a small mountain stream having, for most of the year, a very low discharge. Except for in the winter and spring periods of water abundance, these mills do not have the possibility of using the flow of the river to work in a continuous manner; therefore, it is necessary to realize a large storage water reservoir, called a “per le refogge”, upstream from the mill. The mills utilize the accumulated water in the reservoir until it is exhausted, and then have to wait until it fills up again. The working times are limited, whereas the water resource that can be used is related exclusively to the storage capacity of the reservoir, estimated at about  $900 \text{ m}^3$ . According to the previous assumptions, it would have an uptime to the mill equal to the ratio between the volume of the reservoir and the outlet flow:  $t = V/Q \approx 6$  h. It follows that, in summer and autumn, the mill could be used only for a limited number of hours during the day. This was probably for the purpose of having a working cycle to the day: during the night, the reservoir was filled, while during a few hours of the day, the accumulated water was

used to grind. All the others mills on the Tordino have an available minimum flow rate, high enough for continuous functioning, particularly downstream of the confluence with the Vezzola tributary. The head decrease, for a less steep river bed, is compensated by the substantial increase in derivable flow, thus maintaining sufficient power for the machinery of the mills to be used.

## 6 The Mechanisms

The mills for grinding on the Tordino River all have horizontal wheels. The only vertical wheel, as mentioned earlier, is used for copper processing in the Villa Tordinia mill (Fig. 7).

The technology of the horizontal wheel is the most widespread in central Italy, being the most suitable for harnessing the energy of rivers with low flow. Mills with horizontal wheels have two floors: on the lower floor, there is the wheel, resting with a punch (“punteruolo”) on a solid wood base (called “banchina”); the wheel has spoon-shaped paddles (called “palmule”) arranged almost vertically; these were originally made of oak wood. The water pressure on the paddles produces the rotation of the wheel which is transmitted to the mill, at the upper level, with a connecting shaft that crosses the ceiling.



**Fig. 7** Horizontal wheel watermill from *L'architecture hydraulique, ou l'art de conduire, d'élever et de ménager les eaux pour les différents besoins de la vie* (1737) by Bernard Forest de Belidor (1698–1761)

The traditional technology of horizontal wheel mills has remained essentially unchanged over the centuries, as shown in the number of historical studies and treatises (for example Ramelli 1588; Mariotte 1686; de Belidor 1737; Smeaton 1794), despite some improvements related to the use of the materials. In Fig. 8, we can observe an historical drawing of this kind of mill, a tract with the title *L'architecture hydraulique, ou l'art de conduire, d'élever et de ménager les eaux pour les différents besoins de la vie* (1737) by Bernard Forest de Belidor. Belidor realizes an axonometric cross-section and combines, in a single drawing, the interior and exterior of the building, highlighting the connections between the various mechanisms. It also shows, in plan and elevation, the horizontal wheel and the last part of the channel, with the narrowing that allows for minimization of the head losses. For centuries, in Italy, especially in the Apennines, this model has been used in the practice of construction, although it was less efficient than the vertical mill wheel, already known at the time of Vitruvius. Indeed, it was convenient for its greater simplicity of construction, and the lower costs of construction and maintenance. It was also sufficient for the needs of production of the mountain villages in which it was made. It is necessary to note that mathematicians and engineers, for a long time, were unable to achieve satisfactory results in their treaties and studies regarding the understanding of a mechanism that was used successfully for centuries in construction practice and was well known in the constructive knowledge of the artisans (Figs. 8, 9, 10 and 11).

For example, Parent and Polhem achieved incorrect results, reported in a portion of the Treaty of Belidor (for a greater knowledge of the history of waterwheels: Aliberti 2007; Bertrand 1978; Bloch 1963; Forbes et al. 1958a, b; Forbes 1965; Rouse and Ince 1957; Stowers 1958).

In traditional horizontal wheel watermills, the connecting shaft directly moves an upper millstone that rotates on a fixed inferior one. The grain is dropped into the central hole of the upper millstone from the “tramoggia” (a funnel square box); when ground, it accumulates in the “farinaio”, a robust container which also has the function of supporting the millstones. In order to obtain different products, you can

**Fig. 8** Millstone for cereal grinding



**Fig. 9** Undershot vertical water wheel for copper processing



**Fig. 10** Horizontal wheel of the Comignano mill



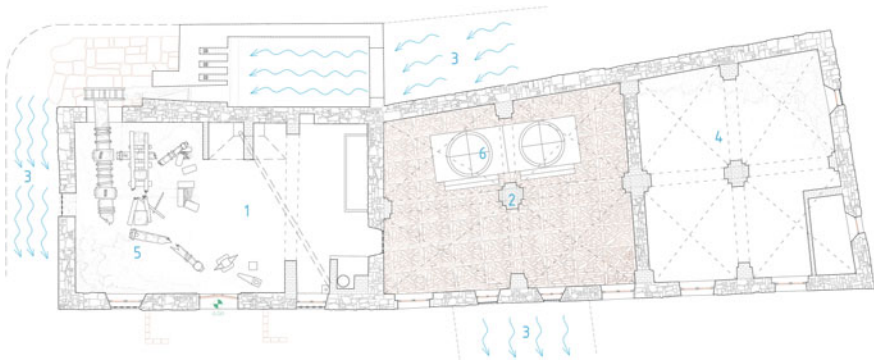
**Fig. 11** Metallic waterwheel in Faieto mill







**Fig. 12** Villa Tordinia mill



**Fig. 13** First floor of the Villa Tordinia mill. Legenda: 1 copper processing room; 2 cereal grinding room; 3 water streams; 4 storehouse; 5 copper processing mechanisms; 6 grinding mills

adjust the level of the upper millstone. Millstones have a rough surface and they were engraved with a pointed hammer, making spiral grooves, realized in opposite directions in the upper and inferior millstone. To obtain the best product, the rotation speed should be between 50 and 100 rpm, but in horizontal wheel mills (where one wheel revolution corresponds to a rotation of the mill) you generally have 15–20 rpm. Mills downstream, of greater dimensions, generally have two waterwheels and two millstones: one for wheat and one for other cereals. Between the end of the 19th and the beginning of the 20th centuries, wooden mechanisms were frequently replaced with cast iron ones, as in the Faieto and Sabatini mills. In three of the factories, in addition to the mill for grinding cereals, there was also an oil mill (called a “trappeto”), with presses for olives. The Faieto mill contained the only fulling mill in the entire Tordinio territory, although it was removed in 1905 (Figs. 12, 13, 14, 15, 16 and 17).



Fig. 14 Villa Tordinia grinding mechanisms

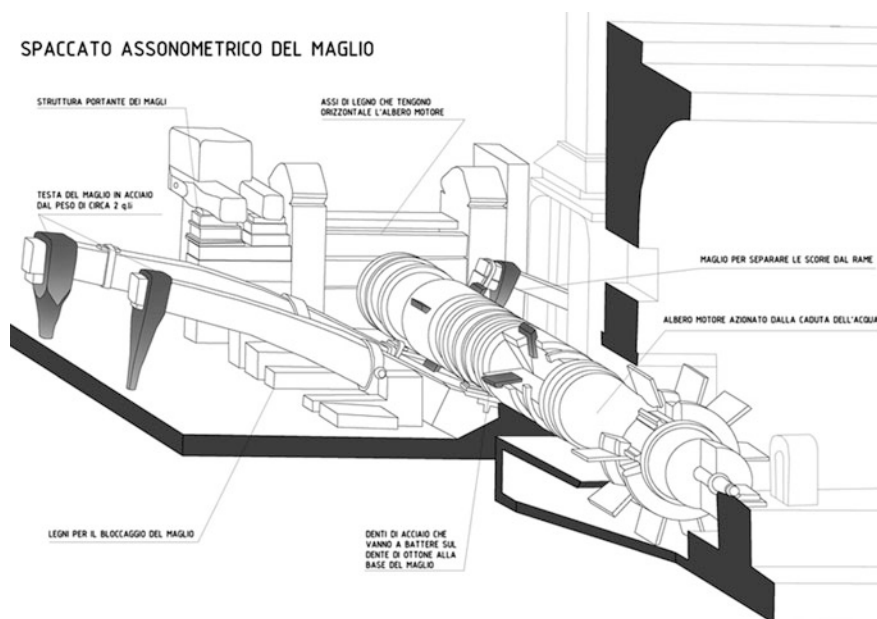


Fig. 15 Axonometric reconstructive scheme of copper processing mechanisms (re-worked version Clementi et al. 1985)



**Fig. 16** Photogrammetric three-dimensional reconstruction of the vertical wheel and camshaft for copper processing in Villa Tordinia mill. The reconstruction was realized with the software Autodesk 123D Catch



**Fig. 17** The hammer for copper processing in the Villa Tordinia mill

In Villa Tordinia, there are two cereal grinding mills and a mechanism for copper processing. This was realized after an expansion of the building occurred around the mid-19th century. The water head race runs along the side of the mill, directly moving a vertical wheel that activates the mechanisms for copper processing. The paddles of the vertical wheel have a flat surface, different from the spoon-shaped ones of the horizontal wheels.

For copper processing, water power is used to move two mechanisms: the hammer (“maglio”) for metal working and the bellows for furnace ventilation (useful for maintaining consistently high temperatures and avoiding sudden changes).

The waterwheel puts a camshaft directly into rotation that moves in the opposite direction of the hammer, shooting the bottom of the handle of the hammer, which has a fulcrum in an oscillation axis.

With the rotation of the camshaft, the hammer is lifted abruptly and, when the contact with the hammer handle finishes, it falls heavily on the anvil.

The speed of action of the hammer depends on the product of the cams number for the number of camshaft rotations in the unit of time, and it can be changed by maneuvering the gate so as to regulate the water flow.

The hammer heads have different weights, to generate different pressures, for copper plastic deformation or for forging it.

## 7 Conclusions

Watermills are complex systems, composed of buildings, hydraulic works and mechanisms, each one defined by the modification and stratification processes that occurred over the centuries, standing as testimonials to past cultures and events.

The progressive abandonment of mountain areas, countryside and smaller towns has led to the loss of the collective memory of material and immaterial heritage; it follows the need of the preservation of cultural historical heritage.

According to the actual meaning, a restoration is based on a heritage’s value knowledge. The watermills have many kinds of value: architectural and cultural, material and intangible.

Although this research is focused on the study of mills present in a small territory, we think that it could have a greater interest: first, because the adopted methodology of study presents a general nature, which can be used to analyze mills elsewhere; secondly, because, at the same time, historical mills are the outcome of local events, but they also present recurrent typological and technological solutions, useful for understanding other mills. This is for two reasons: mills are consequences of the environmental conditions, and similar contexts may be found in other remote areas; a mill’s technical solutions are the result of a tradition with roots in the Mediterranean world and the Roman Empire, and they were built even later according to notions diffused by the circulation of treaties and manuals.

We hope that the results of this research can promote two purposes: on the one hand, contributing to the knowledge of historic mills, addressed to the scientific community; on the other hand, disseminating that the mills—their buildings, mechanisms and hydraulic works—represent cultural heritage, fostering a widespread culture of conservation and valorization of the mills and their landscape.

## References

- Aceto F (2006) *Teramo e la valle del Tordino*. Tercas, Teramo
- Aliberti G (2007) *L'evoluzione delle tecniche molitorie in Italia nell'Ottocento*. Giunti e Barbera, Firenze
- Bertrand G (ed) (1978) *Histoire des techniques*. Gallimard, Paris
- Bloch M (1963) *Mélanges historiques*. SEVPEN, Paris
- Brandi C (1963) *Teoria del restauro di Cesare Brandi*. Lezioni raccolte da L. Vlad Borrelli, J. Raspi Serra e G. Urbani. Edizioni di Storia e Letteratura, Roma
- Burri E, Centofanti M (eds) (2000) *Parco Nazionale del Gran Sasso e Monti della Laga*. Carsa, Pescara
- Castellucci G (2011) *La memoria nel paesaggio*. Ricerche & Redazioni, Teramo
- Centofanti M, Brusaporci S, Di Donato A (2013) *Il sistema insediativo storico e gli opifici nei paesaggi lungo il fiume Tordino*. In: Conte A, Filippa M (eds) *Patrimonio e Siti UNESCO Memoria, Misura e Armonia*. Gangemi Editrice, Roma, pp 239–249
- Centofanti M, Brusaporci S, Di Donato A, Lucchese V (2014) *Architectures and mechanisms. Water mills for cereal grinding and copper processing*. In: IFToMM workshop on history of meachine and mechanism science—Palermo 2013. Edizioni Scientifiche e Artistiche, Napoli
- Ciampani D (1999) *I mulini idraulici nella valle del Tordino*. Andromeda, Colledara
- Cigola M, Ceccarelli M (2011) *Historical development of paper mills and their machines in South Latium during the nineteenth century*. In: Portilla JM, Ceccarelli M (eds) *History of machines for heritage and engineerig development*. Springer, London, pp 85–117
- Clementi A et al (1985) *Archeologia industriale nel Parco del Vera*. Università degli Studi dell'Aquila, L'Aquila
- Continenza R, Brusaporci S (2012) *Cultural heritages in Aterno Valley (Italy): historical watermills for cereals grinding*. In: Koetsier T, Ceccarelli M (eds) *Explorations in the history of machines and mechanisms*. Springer, Berlin, pp 261–275
- Cooperativa Arkè (1998) *Di pietre, legno ed acqua; i mulini della montagna teramana*. Cogecstre, Teramo
- Cortese ME (1997) *L'acqua, il grano, il ferro*. Edizioni All'Insegna del Giglio s.a.s, Firenze
- Costantini M, Felice C (eds) (1993) *Abruzzo e Molise. Ambienti e civiltà nella storia del territorio*. In: Cheiron-Materiali e strumenti di aggiornamento storiografico X, n. 19–20
- de Belidor BF (1737) *L'architecture hydraulique, ou l'art de conduire, d'élever et de ménager les eaux pour les différents besoins de la vie*, Paris
- Demangeot J (1965) *Geomorfologie des Abruzzes Adriatiques*. Memories et Documents du CNRS, Paris
- Di Donato A (2012) *Analisi, tutela, recupero e valorizzazione dei mulini lungo il corso del fiume Tordino*. Tesi di Laurea Corso di Laurea Magistrale in Ingegneria Edile-Architettura U.E. - Università degli Studi dell'Aquila, a.a. 2011–2012, relatore prof. Mario Centofanti, L'Aquila
- Duby G (1968) *Rural economy and country life in the medieval West*. University of Soth Carolina Press, Columbia
- Feliciani F, Pellegrini W (1985) *Archeologia industriale in Abruzzo*. Stabilimento litografico Gran Sasso, L'Aquila
- Forbes RJ (1965) *Studies in ancient technology*. EJ Brill, Leiden
- Forbes RJ et al (1958a) *Power*. In: Singer C et al (eds) *A history of technology*, vol II. Oxford University Press, Oxford, pp 589–622
- Forbes RJ et al (1958b) *Power to 1850*. In: Singer C et al (eds) *A history of technology*, vol IV. Oxford University Press, Oxford, pp 148–167
- Foresti F, Baricchi W, Tozzi Fontana M (eds) (1984) *I mulini ad acqua della valle dell'Enza*. Economia, tecnica, lessico. Grafis Edizioni, Casalecchio di Reno
- Franchi Dell'Orto L (ed) (1991) *La valle dell'alto Vomano ed i Monti della Laga*. Carsa, Pescara
- Grand R, Delatouche R (1950) *L'agriculture au Moyen Age: de la fin de l'Empire Romain au 16 siecle*. E. De Bocard, Paris

- Liberato G, Di Altobrando S (2001) I diciotto mulini dell'alto Tordino. ITGC Forti, Teramo
- Maestri D, Centofanti M, Dentoni Litta A (1992) Immagini di un territorio. L'Abruzzo nella cartografia storica 1550–1850. Regione Abruzzo, L'Aquila
- Makkai L (1981) Productivité et exploitation des sources d'énergie (XIIIe-XVIIe siècle). In: Mariotti S (ed) Produttività e tecnologie nei secoli XII-XVII, Atti della Terza Settimana di Studio dell'Istituto Internazionale di Storia Economica Datini F, Prato 23 aprile-29 aprile 1971, Firenze, pp 165–181
- Mariotte M (1686) *Traité du mouvement des eaux et des autres corps fluids*, Paris
- Pellegrini W (1985) *Macchinando per le vie del teramano*. Tecniche di lavoro e oggetti di altri tempi. Polis Edizioni, Atri
- Pellegrini W (2003) *Antiche industrie di farina olio e vino: documenti di storia del lavoro e delle tecnologie in agricoltura lungo i corsi di Vomano, Fino e Piomba*. Provincia di Teramo - Comunità montana, Cermignano
- Pirenne H (1937) *An economic and social history of medieval Europe*. Harcourt Brace, New York
- Ramelli A (1588) *Le diverse et artificiose machine del capitano Agostino Ramelli dal ponte della Tresia ingenerio del Christianissimo Re di Francia et di Pollonia*
- Reynolds TS (1984) Le radici medioevali della Rivoluzione industriale. In: *Le Scienze*, vol CXCIII, pp 110–121
- Rouse H, Ince S (1957) *History of hydraulics*. In: *La Houille Blanche*. Iowa Institute of Hydraulic Research, State University of Iowa
- SIGEA (2011) I mulini ad acqua: risorsa di ieri e di domani. *Geologia dell'Ambiente* 3/2011
- Singer C et al (1958) *A history of technology*. Oxford University Press, Oxford
- Slicher van Bath BH (1963) *Agrarian history of Western Europe*. Arnold, London
- Smeaton J (1794) *Experimental enquiry into the natural powers of wind and water to turn mills*, London
- Stowers A (1958) Watermills c 1500 c 1850. In: Singer C et al (eds) *A history of technology*, vol IV. Oxford University Press, Oxford, pp 1998–2122
- Tielden F (1957) *Interpreting our heritage*. The University of North Carolina Press, Chapel Hill

# The Mill at the Orbetello Lagoon: Mechanisms and Hydraulic Energy

Emanuela Chiavoni

**Abstract** The objective of this research was to investigate, by means of direct knowledge and analysis of historical sources, the running and mechanisms, including hydraulic, of the windmill on the Orbetello lagoon. Currently, evidence indicates that this particular architectural heritage was just one of nine historic mills that no longer perform their original function. Also, the conformation and characteristics of the lagoon are no longer the same as those of the period in which the mills arose.

## 1 History

Long out of use, the mill at Orbetello is located on the lagoon in the town's historic centre. Orbetello is a municipality in the province of Grosseto, known for the nature reserve in the middle of the lagoon, and joined to Monte Argentario by a road built on an embankment (the artificial dam was built in 1842 by Leopold II, Grand Duke of Tuscany), which divides the lagoon into two parts: the Levant and the Ponente. A rare postcard presented here depicts the Garibaldi theater and bathing establishment in the Levant lagoon on the left, and the Iris theater and bathing establishment in the Ponente lagoon on the right. Portions of Piazza Umberto I (now Piazza del Popolo), the Etruscan walls, the embankment, the mill and Monte Argentario can also be seen (Figs. 1 and 2). In 1913, the Società Nazionale Ferrovie e Tramvie of Rome inaugurated a railway line running along this embankment. The "Baccarini" train traveled between Orbetello and Porto Santo Stefano for thirty-odd years, until the line was bombed in 1944 (Fig. 3). Though many attempts were later made to repair the line, none met with success, and service along the route was never restored (Figs. 4 and 5).

---

E. Chiavoni (✉)  
SDRA, Rome, Italy  
e-mail: emanuela.chiavoni@uniroma1.it

**Fig. 1** Orbetello, the embankment and view of Monte Argentario, Torriti and Ulivi postcard, ca. 1910. In Savoi and Andruccetti (1994)



**Fig. 2** Orbetello, Iris theater and bathing establishment. In the foreground, the mill and the Iris bathing establishment, Carlo de Vitt postcard, ca. 1929. In Savoi and Andruccetti (1994)

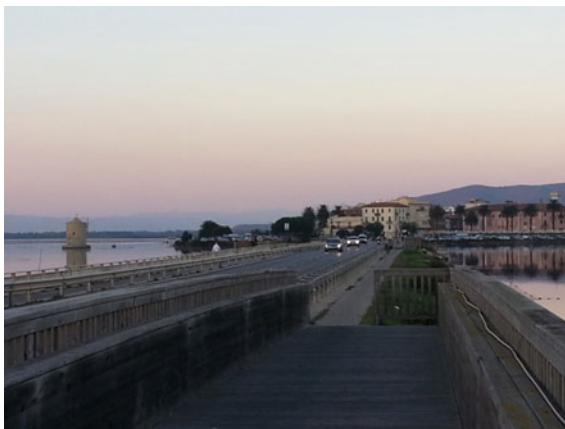


**Fig. 3** The embankment and railway line, original postcard photograph, property of Dalle Nogare, Armetti and C., Milano (1939). In Savoi and Andruccetti (1994)





**Fig. 4** Photograph of the embankment (Chiavoni 2014)



**Fig. 5** Photograph of the embankment with the mill in the foreground (Chiavoni 2014)



Construction of the mill probably dates back to the end of the 14th century or the start of the 15th, when, having become lords of Orbetello, the Counts Orsini (circa 1358) sponsored many new works in the town. In 1414, the mills were assigned to the community of Orbetello and were later purchased by private individuals. Unfortunately, there are no testimonies from that period, since the ancient documents stored in the Orbetello Municipal archive were lost or destroyed around 1454.

This is the only surviving mill of the nine that once stood in the area. They were all similar and arranged in a line within close range of each other. In the ancient texts, the words ‘pond’ and ‘lagoon’ are used indifferently, and even the term ‘marine lake’ appears, owing to its connection to the sea. The historical maps analysed dating from 1573 to 1742 show Orbetello’s system of mills, with a total of nine represented in some layouts but others showing fewer, as they had disappeared (Figs. 6 and 7). As time went on, all but the one remaining mill were destroyed. In

**Fig. 6** Historical map of Orbetello, circa 1647, approximately. Paper Color cm. 37 × 47 engraved copper Valerio Spada in Florence



**Fig. 7** Plant Orbetello; paper cm. 29 × 36 performed by Jacques Lagniet 1620–1672



addition to the windmills at Orbetello, the area boasted two others, one at Porto Ercole between Forte Filippo and Santa Caterina, and another at Talamone. There were also three watermills in the Argentario Valley belonging to the Chigi family, who had property in the area and were already engaged in trade there. Though nine mills seems too many for a population of around 2000 inhabitants, it has been suggested that the milling industry was particularly flourishing at the time, as the lagoon was more navigable than it is now and grain could thus be transported by sea. It is likely that all the mills were in operation until the early 1800s, after which the number of active mills continued to drop. Most were used only as storehouses until 1917, when Orbetello's western airfield was laid out.

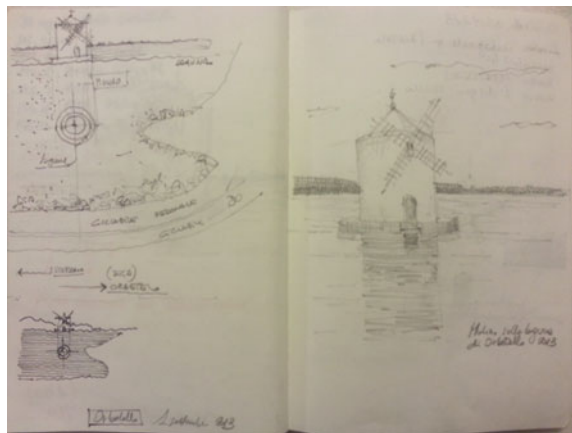
## 2 The Mill Today

The surviving windmill is cylindrical in form, with horizontal circular sections of 5.80 m in diameter on the outside and a wall thickness of around 68 cm (Fig. 8). It is around 6.95 m tall and covered on top by a cone measuring around 1.40 m in height. It rests on a wider base, again cylindrical in shape and measuring around 8.10 m in diameter, rising out of the water by around 80 cm (obviously, this varies greatly) (Figs. 9, 10 and 11).

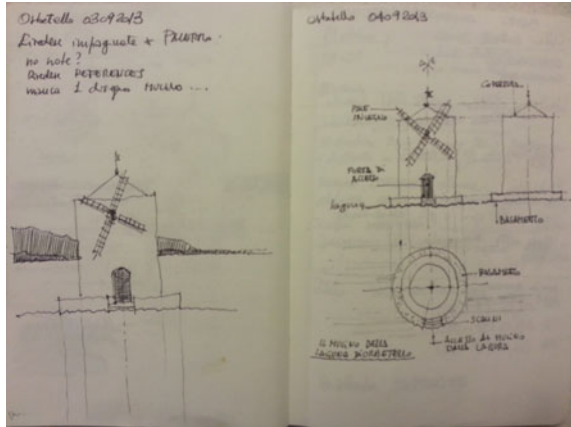
The original construction was built from stone and cement but, during restoration work in 1967 and again in 2000, other materials were inserted to fill in the damaged sections, and copper fixtures and finishings were added as protection from rainwater, along with four wooden sails with steel joints inspired by the design of the ancient sails represented in the engraving by C.H. Wilson in 1832, although smaller. According to some texts by A. Ademollo in 1800, later recovered and defended by Caciagli (1971) and which also appeared among the historical information regarding the Monumental Buildings of the municipality of Orbetello (Fig. 12), the system of nine mills probably ensured that the nutritional needs of the town were met, with the grinding of wheat taking place thanks to the movement of the water caused by the tides.

Wheat was transported to the mills on the small boats typically used on the lagoon in Orbetello and the mills “*did not grind the wheat by means of the wind and sails, as happened later, but thanks to a device driving the water from the pond itself*”. It is understood that, “*in former times, [the mills] exploited the ebb and flow of the seawater (particularly sensitive in Orbetello’s pond) which, every six hours or so, would enter and leave the pond from the tombolo at Giannella near the fish pond tower, causing a large-scale hydraulic phenomenon*”. The nine mills were probably placed in a line as a way of getting the most out of this regular movement of the waters and the constant currents. More recently, these hydraulic machines

**Fig. 8** Pen drawing (E. Chiavoni) of the mill today on the Lagoon (2012)



**Fig. 9** Pen drawing (E. Chiavoni) of the mill today on the Lagoon (2013)



**Fig. 10** Photograph of the mill today on the Orbetello Lagoon (Chiavoni 2012)



**Fig. 11** Photograph of the mill today on the Orbetello Lagoon (Chiavoni 2012)



were given sails to exploit wind power. The sails were directed in such a way as to best exploit the force of sirocco and mistral winds.

Today, in addition to embellishing the panorama around the lagoon, the mill is an important feature of the landscape, both because it bears witness to the system of mills of which it was a part (something known only to those who are familiar with the history of Orbetello), and because it evokes a time-honored practical function that was vital to mankind's survival. Every day, the mill's appearance changes with the passing hours and the shifting light, the shadows on its walls creating an entire palette of colors and effects. At certain times of day, the mill's reflection in the still waters of the lagoon gives us two simultaneous images, a real mill and its virtual twin, each equally entrancing. This architectural emergence attracts a steady stream of photographers, both professionals and passers-by. And for those whose work involves increasing our knowledge of cultural asserts, it is important to record and document the architectural heritage and its setting, not only through photography, but also with watercolor representations (Fig. 13).

Using color captures the characteristics of a subject more intensely, as well as enriching and completing our ability to convey all of the aspects that help make the reality we see before us recognizable (Fig. 14).



**Fig. 12** The Orbetello Mill—Survey Plate 23—Historical changes in built-up areas showing types of characteristic buildings

**Fig. 13** The Orbetello lagoon, watercolor sketch (E. Chiavoni)



It is, thus, a form of analysis that is essential for understanding architecture, a scientific process based on the recognition of shapes, spaces, volumes and proportions which starts with choosing among different methods and tools, favoring those that provide the most pliant means of achieving the best results, and which are, thus, most useful for representing things as they are. Surveying is used as a process of verification that makes it possible to retrace the history of the analyzed object, so that it can be maintained and valorized. It is the interpretative investigation that activates a process of analysis of the individual elements, and which then reassembles the various parts and finds the links that bind them together. The method of study starts from understanding, and drawing is the main author of this procedure; if well done, the graphical representations thus produced can also provide administrators with suggestions for better and more informed management.

**Fig. 14** The Orbetello mill, watercolor sketch (E. Chiavoni)



### 3 Hydraulic Mechanisms

G. Della Monaca's most recent text talks about *"the work done by the mills. There are seven located on the lagoon near the sea gate and others found inland from Porto Ercole and Talamone. The mills on the lagoon were not always working, however, thus, the mills at Porto Ercole were often used. There were even plans to activate a mill within the town walls of Orbetello as a solution for this inconvenience"*. Referring to this sentence, a footnote states that, *"there were nine windmills on the lagoon, but two of them were used for other purposes; the seventh was used as a shelter for fisherman and the last one as a deposit for drinking water from the Monte Argentario springs"*. A subsequent note in the same text states that, *"The mills at Orbetello were wind-driven, although a report written by the mayor of Orbetello, Domenico Maria Sances, dating back to 18 October 1809, suggests that they were later transformed into watermills: in the report, the mayor communicates the state of the watermills that are found in the outskirts of the town, as no windmills are known"*. The historical information that has so far reached us does not always correspond and is sometimes contradictory; so it is not possible to say with



certainty whether the mills on the lagoon in Orbetello started out as watermills or windmills, as stated by some, although several opinions agree that, in different periods and conditions, they alternated between both water energy and wind energy. Nor does an analysis of the surviving mill, which helps us understand its ancient architectural conformation, aid our understanding of how the mechanism exploiting water energy might have worked.

Definite sources have not been found, but some texts dealing directly with the problem of the hydraulic mechanism provide some indications. In the text by G. Caciagli, we read: “...we should assume that the “*buhrstone wheels*” that were used were powered directly by the driving wheels arranged horizontally inside the base of each mill and constantly submerged in water. Thus, the mechanism was “direct driven” via a single fixed shaft on the millstone which ground the wheat, provided there was no gear reducing device between the driving wheel and the “*buhrstone wheel*”. We can also assume that the alternating movement of the water required no special shape for the blades on the driving motors, but doubtless the constant immersion of the wheels in the seawater must have caused considerable lubrication and maintenance issues against inevitable oxidation. This would explain the later adoption of the sail system to exploit the power of the wind”.

## 4 Gearing

The *buhrstone mill* mentioned by Caciagli enabled the grinding of wheat and was one of the oldest types of mill in history. It probably consisted of two wheels made of very hard stone, only one of which was fixed while the other was allowed to rotate. These wheels have a number of grooves. It is thought that the wheat passed through the cone to reach the centre of the pulveriser and had to go through the space between the two wheels, after which it was broken up by the compression forces and finally expelled radially in ground form.

There were two varieties of this type of mill, one with a vertical wheel and the other in which the wheel was horizontal. The latter is likely to have been used in the mills on the lagoon. The horizontal wheel mill had small millstones that carried out an entire rotation every time the water wheel turned and only small quantities of current water were needed for them to function.

The horizontal wheel, or *ritrecine*, consisted of a central pole with recesses engraved into the larger, lower part. This mechanism was secured to the upper rotating millstone by means of an iron crossbar and was activated by water.

The aim of the research, which is still underway, is to contribute to our understanding of the system of mills on Orbetello's lagoon and how they operated in history, in order to safeguard and sustain the only remaining mill.

## 5 Conclusions

The study aimed to increase our knowledge of several of the area's features, including the Orbetello mill, and to identify methods and tools for valorization.

Attention focused on understanding not only the historical and architectural aspects, but also the hydrographic aspects of the machinery and gearing that influenced and characterized the mill. The attention devoted to the architectural aspects is closely linked to the survival—which is by no means to be taken for granted—of such distinctive elements as the millstones, sluices, sails, and mechanisms, which in this case cannot be completely recovered. From a methodological standpoint, this process can be achieved only by starting with a careful census of these cultural assets, identifying their location, classification, number, and dimensions, proceeding with historic and constructional studies until an understanding of their relationship with their surroundings is gained.

One of the aims is to answer the need for knowledge about this mill, which belonged in the past to a particular system of multiple mills related to other systems in the region, given that this building offers potential for repurposing. Only a thorough analysis of such buildings can make it possible to think in terms of development from the standpoint of the networks, systems and routes whereby we can rediscover the region's more recent history through the material testimony it has left behind. It is also important to highlight this building's value for culture and tourism in order to make it better known and appreciated at the regional and national levels.

Accordingly, it is necessary to improve and extend our knowledge of these cultural assets that are so closely linked to mankind's work, with particular reference to the specific system of production, and thus also raise awareness among public and private institutions and individuals of the importance of safeguarding this cultural heritage.

## References

- Caciagli G (1971) *Lo Stato dei Presidi*, Firenze
- Chiavoni E (2012) The drawings of machines by the great architects of the renaissance and Baroque Eras. In: *Explorations in the history of machines and mechanisms*. Proceedings of HMM2012. Springer, Dordrecht
- Chiavoni E (2014) Il sistema degli antichi mulini ad acqua nell'Alto Lazio. Conoscenza, documentazione e valorizzazione. In: *RE USO, 2° Convegno Internazionale : La cultura del restauro e della valorizzazione*. Temi e problemi per un percorso internazionale di conoscenza. Firenze 6–8 novembre 2014
- Graziani E (1985) *Il mio mulino*. In: *Dove e quando International*, Year., A.T.L.A. s.n.c. Pitigliano (GR)
- Savoi L, Andruccetti B (1994) *Orbetello una storia*, Editrice Caletta (kindly loaned by Giorgio Bastogi, Orbetello)
- Poletto A (2006) *La laguna dei mulini*, Ex Cogita Editore (Aggiungere Anno)

# The Sulphur Mining Industry in Sicily

Vincenzo Ferrara

**Abstract** A brief history of the Sicilian sulphur industry from the mid-19th to the mid-20th centuries. Inhumane working conditions of “zolfatari” and “carusi”. Machines for the extraction of ore. Trade and export of sulphur: French and British merchants. Systems for melting sulphur. The Herman Frasch process and the end of the Sicilian world sulphur monopoly. The Cozzo Disi sulphur mine in Casteltermini: project of restoring and transforming it into a “Museum Mine”. The role of sulphur in the Italian Government’s decision to colonize Libya. An adventurous Sicilian explorer: Ignazio Sanfilippo.

## 1 A Brief History of the Sicilian Sulphur Industry from the Mid-19th to the Mid-20th Centuries

Archaeological finds kept in Palermo and Agrigento museums show that sulphur was discovered in Sicily at an early date and that the native peoples (Sicanians, Sicels, Elymians) already used sulphur and exported it to Greece and Northern Africa from 900 BC. Moreover, studies indicate that, by the end of the 2nd century AD, a number of mines were active in Sicily employing slaves and criminals. Arab geographic literature from the 9th–11th centuries AD contains mentions of sulphur mines in Sicily where the high temperatures caused the loss of the miners’ hair and nails (Barone 1989).

The Industrial Revolution and the need for gunpowder were the main reasons for the growth of sulphur mining in Sicily in the late 1700s. Sulphur was also used to manufacture matches, in wine growing and to produce fertilizers, but the greatest request for Sicilian sulphur was connected to its use in the production of sulphuric acid, used as a reagent in the French and British chemical industries.

---

V. Ferrara (✉)  
Palermo, Italy  
e-mail: vferrara1948@libero.it

In this connection, Sicily emerged as the most important sulphur-producing area of the Industrial Age.

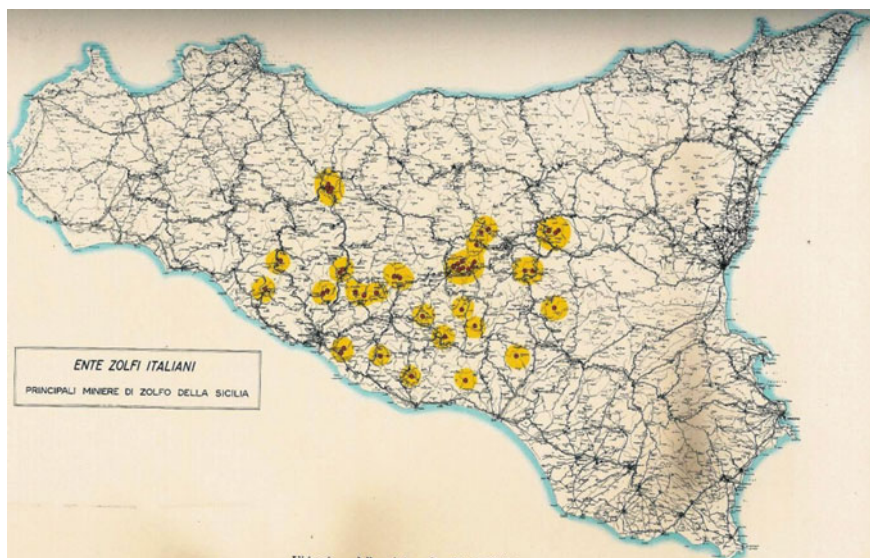
In the 19th century, the island was the world's primary commercial source of sulphur-bearing compounds and maintained its monopolistic position for over 150 years until the end of World War I.

A massive sulphur vein, in fact, the largest easily available sedimentary deposit of native sulphur in the world, called "Sicilian gold", extended principally into the provinces of Enna, Caltanissetta and Agrigento, where major mines were located (Fig. 1).

By 1832, there were already 190 mines operating in Sicily, mainly in the Caltanissetta and Agrigento areas, producing 90,000 tons of sulphur, 40,000 of which were exported (Squarzina 1963). In 1886, the number of mines had increased to 664, but only 373 of them were active, and in 1899, 733 mines were operating in Sicily with a total production of 537,093 tons of sulphur (Musco 1961).

Despite the rapid expansion, until after the unification of Italy in 1860, sulphur mining failed to transform that area into a significant industrial centre due to poor internal communications—there were hardly any railways in Sicily—backward technology, fragmentation of sulphur deposits into many small mines and lack of investment.

In most cases, the ownership of the mine and its operations were separate, because landlords rarely took an active part in the operations. The mines were managed by "gabello" through contracts that gave the landlords a fixed lease paid in kind called "estaglio" (generally, 15–20 % of the sulphur production). Other than that, all the economic benefits of production went to the "gabello", whose interest,



**Fig. 1** Major sulphur mines in Sicily

therefore, was that of investing as little as possible in efficiency, safety and modernization of the plants and speculating as much as possible between the “estaglio” and the activity expenses.

Flooding and fires were the most common reasons for abandoning a mine, since it would have been too expensive to control water and fire.

As a result, the industry remained primitive until the beginning of the 20th century, when massive investments improved the efficiency of some of the largest mines. This was also required by the necessity to challenge a powerful competitor: low cost American sulphur.

## 2 Inhumane Working Conditions of the “Zolfatari” and “Carusi”

Originally, Sicilian sulphur was extracted from open-pit mines. Later, the mining was done below the surface of the earth: in 1850, the average depth of Sicilian mines was only 19 m, in 1870, 50 m, and by 1890, the average depth had increased to 80 m, with a maximum of 195 m in two of them. At the beginning of the 20th century, the expansion of mining activity and some increased mechanization had brought the average depth to 300 m (Squarzina 1963).

Working conditions in Sicilian sulphur mines were inhumane and dangerous. Mining was still largely unmechanized and labour-intensive, with “zolfatari” (miners) working naked in the dark depths of the earth at a temperature of over 40 ° C in a poisonous atmosphere (Fig. 2).

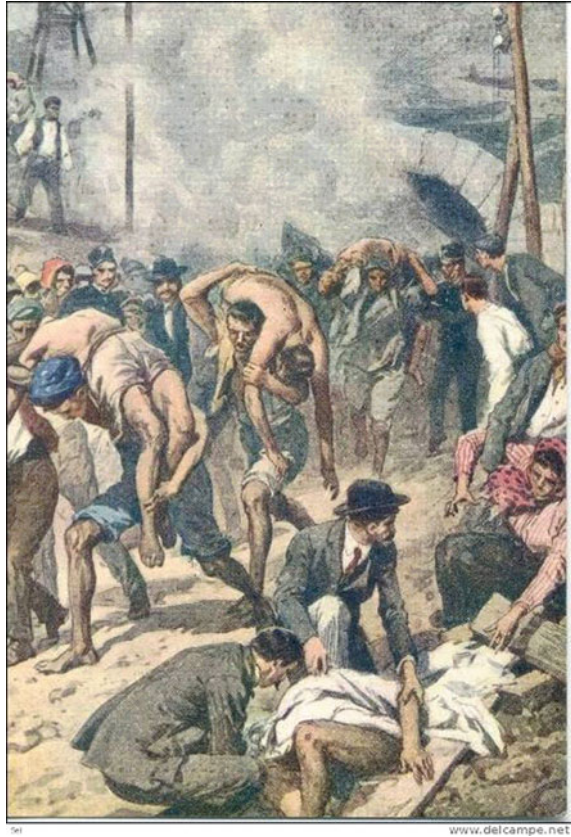
Tunnels were poorly ventilated and the air breathed by workers was humid and unhealthy. The only source of light in the galleries was given off by acetylene lamps or by ceramic lamps filled with oil and a wick inserted and ignited. The flame was exposed to the air. Safety lamps were still unknown.

Since sulphur dust is combustible, the smallest spark could cause a fire. When ventilation was not good, sulphur dust and other flammable gases could easily cause explosions and fires that could last for years.

Fig. 2 “Zolfatari”



**Fig. 3** 1916 Cozzo Disi mine disaster



One of the worst disasters caused by an explosion of gas, followed by the collapse of several galleries and an uncontrollable fire, took place in 1916 at the Cozzo Disi mine located near the village of Casteltermini (Agrigento), when 89 miners were killed and 39 injured (Fig. 3). It took a couple of years before the fire was extinguished and the bodies of the miners could be recovered. The only way to put out an extended fire was to build walls in order to seal off the stretch of tunnel where the fire took place so that oxygen would not feed the fire. This expedient was taken at Cozzo Disi, and in 1918, when the mine was re-opened, the director said that it was like walking through a cemetery, since human remains were found everywhere in the tunnels (Ferrara 2012).

At one time, miners were allowed to dig wherever they found a sulphur vein without any geological study or preparatory plan and with no regard for the safety or the future of the mine. Galleries and inclined shafts were not reinforced. Once the vein was exhausted, the old galleries were abandoned empty and no measures were taken to reinforce the stability of the mine and prevent its collapse. Weak supports

made of pine beams could not protect the workers from falling rocks and landslides, which caused numerous accidents.

Until the mid-19th century, in most Sicilian mines—especially the smallest—the lack of financial means did not allow for the use of wells or pumps to free tunnels from water. Flooding was then another cause of disasters. For the same reason, there were hardly any machines in use for the extraction and carrying of ore to the surface. This job was mainly done by “carusi” (Fig. 4).

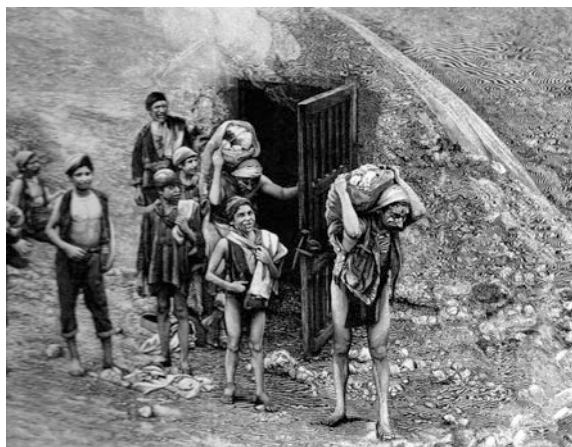
“Caruso” is the Sicilian dialect word for boy. “Carusi”, aged from six to fourteen years old, were engaged by miners to carry the crude ore in straw baskets from the extraction gallery up to the surface, where it was melted and refined. On each trip, they climbed endless steep stairs carrying a weight of about 25/30 kg for the youngest up to 70/80 kg for the oldest.

Each miner engaged from one to six boys to work for him. The miner purchased the “caruso” from his poor family by paying the “soccorsio morto” (dead help), a sum of money in the form of a loan, agreed upon according to the age and strength of the boy. Once this money was paid, as a matter of fact, the miner became the owner of the boy, who, from that moment, was his slave. The “caruso” could only obtain his freedom by repaying the “soccorsio morto”, but neither the poor parents nor the child would easily have found sufficient money for that, and so, many “carusi” remained slaves as adults.

This gruelling work caused frequent cases of curvature of the spine and deformation of the bones of the chest in the young boys. From 1881 to 1884, in the Sicilian mining district, among 3672 men submitted for medical examination, 1634 (44.5 %) were found unfit for soldiering (Squarzina 1963).

More than that, these children were frequently beaten and sexually abused by their masters, also as a result of week-long separations of husbands from wives (Fig. 5).

**Fig. 4** “Carusi”



**Fig. 5** “Carusi”

Salaries were very modest. According to official sources, in 1893, the daily wage of a “child caruso” was 0.60/0.95 Lira; that of an “adult caruso” was 1.70/2.00 Lira. A miner earned 2.00/2.70 Lira for 6/8 h of labour.

The payment of salaries was frequently late and it was often replaced by the “truck system”, a practice introduced by British merchants consisting of paying part of the wage in highly-priced and poor quality goods (food, tools, etc.) sold in stores opened in the mine area and managed by the same “gabello”.

As a result, their wages could suffer a reduction of about 25 %.

### 3 Machines for the Extraction of Ore

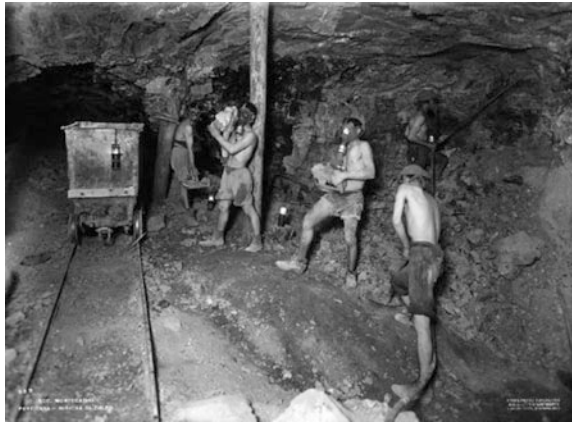
In small mines, carrying the ore to the surface by hand was profitable thanks to the “carusi’s” poor salaries. On the other hand, in mines which had a depth of 150 m or more, the transportation by “carusi” was too slow and expensive. It was, in fact, calculated that, in 1873, the cost of manual transportation of the ore was about 3/3.50 Lira/ton, while the cost of mechanical extraction was about 1.50 Lira. A more careful management, therefore, required more rational and modern transportation techniques. However, the investments needed for this innovation could only be found for large mines, while the small ones still continued to employ “carusi”.

The first primitive mechanical extraction systems adopted in the mid-19th century consisted of carrying the ore by hand to the collection gallery and unloading it onto wooden carriages (Fig. 6).

The carriage rails were simply flat iron bars fixed on wooden crossbeams and held by wedges. This system could only be used for a horizontal transportation anyway and took advantage of a slight slope existing between the piles already formed inside the gallery and outside. Loading and unloading was done by hand (Fig. 7).

Only in the second half of the 19th century did the largest mines begin to be equipped with properly inclined shafts. The most common ones had double rails, one for climbing carriages and one for descending ones. Heavily laden climbing



**Fig. 6** Wooden carriages**Fig. 7** Primitive mechanical extraction system

carriages were often operated by steam engines, while descending ones did not need an engine, but a brake.

In 1865, in 13 Sicilian mines, the extraction work done by “carusi” and mules had already been replaced by steam engines with a total power of 190 HP. Only a few years later, in 1872, 25 steam engines with a total power of 400 HP were in use in 21 mines. In the same period, the first extraction wells were installed in those Sicilian mines which could afford their high cost. Vertical wells, used for the ore transportation, as well as for the drainage of spring waters, reached an average depth of 60–120 m.

The first mechanized extraction system consisted of a masonry hoist tower installed over a well. At the top of the tower, pulleys connected to flat belts were operated by a steam winch in order to lift two elevators anchored to the well. The carriages full of ore were placed inside the elevator and hoisted to ground level.

The introduction of head frames, already experimented with in the coal mines of England, improved the extraction technique. Initially, they were made of wood:

four strong beams held together by horizontal or crossed wooden boards. They were 5–10 m high and had two revolving spools at the top operated by steam engines that made both of them spin simultaneously at the same speed but in opposite directions. In this way, while one spool wound the first rope pulling the full cage from the bottom, the other spool made the second empty cage descend.

A wooden or iron guide was fixed onto the sides of the well in order to direct the cage lifting and allow the elevators to be manoeuvred quickly while avoiding swinging and bumping.

After World War I, some head frames were built in reinforced concrete the structure of which did not differ from that of the wooden ones: the only difference was that the wooden beams and boards were replaced by walls in the form of a right-angled trapezium. Although they had the advantage of having a reduced cost, the continuous vibrations produced cracks in the cement coating protecting the metallic structure. This allowed infiltrations of rain water, which caused damage and, therefore, the life of the equipment was shortened (Cassetti 1989) (Fig. 8).

The most advanced head frames were built with iron or steel and could be up to 30 m high. They were also used as lifts for the workers and their tools. The special carriages elevated by these head frames could transfer the ore from the gallery all the way to the top of the head frame, where a collection container was placed. Conveyor belts then moved the carriages to a stock container from which the ore was automatically loaded onto trucks (Fig. 9).

A further technological improvement to mechanical extraction came in 1898, when the first system powered by electricity was installed in the Tallarita mine (Riesi).

At the end of the 19th century, all the large mines had extraction equipment and, therefore, more than 1/3 of the ore was carried to the surface mechanically (Squarzina 1963).

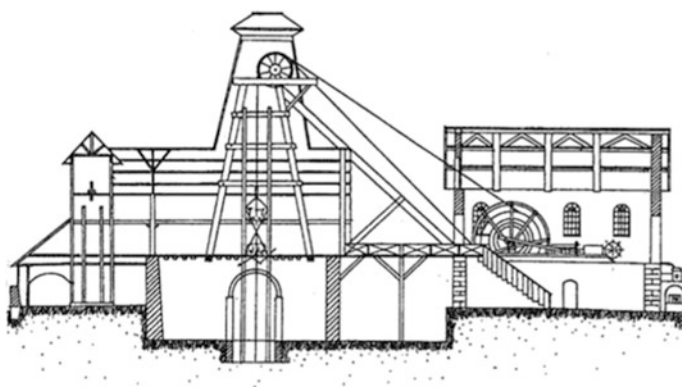


Fig. 8 Iuncio Testasecca mine: design of the extraction well

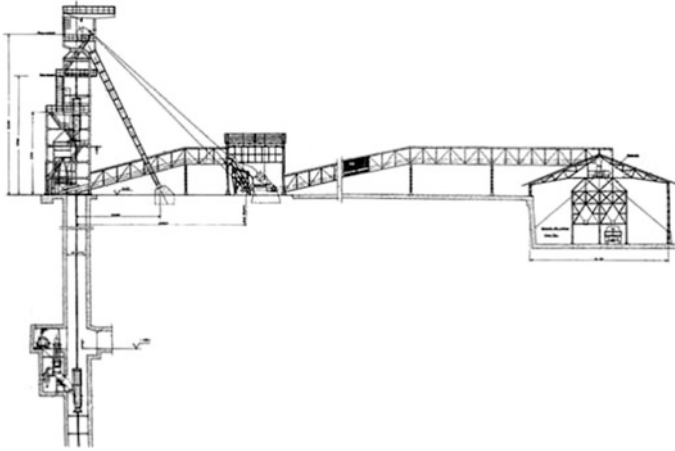


Fig. 9 Gessolungo mine: design of the extraction well

#### 4 Trade and Export of Sulphur: French and British Merchants

Trading of Sicilian sulphur was developed in the early 18th century. It was first exported by sailing boats and later by steamboats. The mineral extracted from the mines located in the Caltanissetta and Enna provinces was mainly transferred to the port of Catania, while Licata and Porto Empedocle were the ports of embarkation to which the sulphur from all the mines in the Agrigento province was taken by mules or carriages. Once there, it was unloaded onto small boats by men who carried the sulphur on their backs, walking chest deep in the water. The small boats then transported the load to the vessels anchored in deep waters. This happened all year round, even in winter.

In the early 19th century, the most important sulphur refineries and sulphuric acid plants were located in Marseilles (Kutney 2007), and France was the major market for Sicilian sulphur. This state of affairs gradually changed with the growth of numerous Leblanc plants in England, which replaced France as the major customer for Sicilian sulphur. By 1830, the Sicilian sulphur trade was dominated by British merchants, already operating in Sicily in the wine trade business. In the first half of the 19th century, Britain and France purchased most of the Sicilian sulphur through exclusive contracts (Cassetti 1989). In the years between 1833 and 1838, Britain imported 49 % of the entire Sicilian sulphur production and France 43 % (Barone 1989).

In 1838, even though Britain was the major buyer of Sicilian sulphur and despite existing agreements with British merchants, the Neapolitan government granted a monopoly for the trade of most of the production to the French company “**Taix, Aycard et C.**” This agreement took the business away from the British, causing a

diplomatic incident which produced a serious military escalation. The British Mediterranean fleet was made ready for war and sent to Naples. Fortunately, diplomacy prevailed and Taix, Aycard et C.'s monopoly was revoked by Ferdinand II against an expensive penalty paid to the French company.

A second attempt at commercial discipline on a voluntary basis started in 1896, when a Sicilian businessman, Ignazio Florio, formed a consortium for the control of the price and export of sulphur. The new joint-venture with British and French investors was named "**The Anglo-Sicilian Sulphur Company**". The company contracted the control of about two thirds of all Sicilian production through ten year sales contracts at a fixed guaranteed price. In this way, the Anglo-Sicilian managed to maintain price stability at a reasonable level during periods of price depression. This state of affairs might have gone on indefinitely had it not been for the entry of American-produced sulphur into the international chemical business. American competition caused a financial crisis for the Anglo-Sicilian, which had to fulfil their obligation to purchase most of the Sicilian sulphur production even though sales and export had considerably decreased.

In 1906, the Anglo-Sicilian was rescued by the Italian Government, which established the "**Consorzio Obbligatorio per l'Industria Zolfifera Siciliana**". This compulsory State consortium purchased the Anglo-Sicilian stock on hand, amounting to over 500,000 tons. A new law obliged the producers to store all their production in the new "Consorzio's" warehouses. They could receive immediate advances on their deposits, but the commerce and trade of sulphur was exclusively operated by the "Consorzio".

This consortium lasted until 1932, when it was replaced by "**Ufficio per la Vendita dello Zolfo Italiano**", in turn taken over by "**Ente Zolfi Italiani**" in 1940 (De Gregorio 1989). After World War II, the Sicilian sulphur industry was barely profitable. Mines survived only thanks to contributions granted by the Government, and Sicilian sulphur gradually became a Government social programme (Kutney 2007). In 1964, the few mines still operating were transferred to the Sicilian Regional Authority, "**Ente Minerario Siciliano**", which acknowledged that even the best mines were no longer competitive and started a gradual closing plan: the number of mines in activity declined from 24 in 1967 to 5 in 1975. In 1988, the last four mines were closed.

## 5 Systems for Melting Sulphur

The simplest method of sulphur purification was that of burning the ore and collecting the molten sulphur after eliminating contaminants.

The earliest system of melting adopted in Sicily was the "**calcarelle**". Until about 1850, it was the cheapest process employed to extract sulphur from rocks. This consisted simply of a circular stack of ore with a diameter of 1.50–2.00 m built in a sloped ditch with a depth of about 1.00 m at the back and 0.50 m at the front (Gatto 1928). The construction of the stack usually took two days and was left open

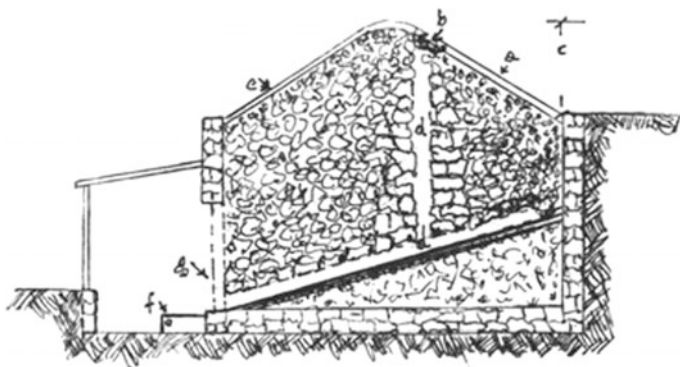
at the top. The mass, consisting of 3–4 m<sup>3</sup>, was ignited at the summit. On the third day, the molten sulphur flowed out through an opening called the “morto” and was collected in wooden buckets (“gaviti”). By this method, two thirds of sulphur contained in the ore was wasted, since it burned vast quantities of sulphuric acid into the air, which caused terrible damage to the vegetation in the neighborhood and, as a consequence, long legal disputes with the landowners.

After 1850, most “calcarelle” were replaced by “**calcaroni**”. These mainly differed from “calcarelle” in size: the diameter of “calcaroni” went from 5 to 30 m and the depth of the ditch was about 5 m at the back and 1 m at the front (Gatto 1928). The more advanced preparation, which included the addition of soil on top of the sulphur stack, and the more sophisticated piling technique allowed for a regulated combustion lasting 30/90 days. Once liquid, the sulphur could flow down the sloping hillside and be collected in the “gaviti”, where, once solidified, it formed blocks (“pani”) weighing 50/80 kg.

With the “calcaroni” process, 35/50 % of sulphur was still lost in the air (Fig. 10).

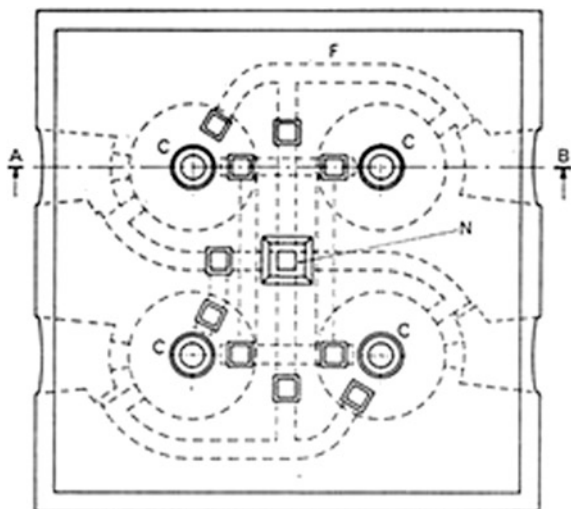
Better results were achieved with the **Gill’s furnace** invented by Robert Gill, a British engineer, director of the Gibellini Sulphur Company. This furnace, entirely made of concrete, was experimented with for the first time in 1880 in the Gibellini mine (Racalmuto). Gill’s process involved the use of a series of chambers (from a minimum of two to a maximum of six).

The main innovation of this furnace consisted in the possibility of recovering the combustion gas and using it again in the following chamber. Since the sulphur fumes produced by this furnace were very limited, the Gill’s furnace could operate continuously all the year round. The most common Gill’s furnace used in the Sicilian mines was the four-chamber one, which had a capacity of about 30 m<sup>3</sup> and a sulphur waste of only 7–10 %. Within a few years, this process was adopted in most Sicilian mines and became the most common method for melting sulphur. In 1890, the sulphur melted in Gill’s furnaces was 12 % of the whole production and increased to 64 % in 1905 (De Gregorio 1989) (Fig. 11).



**Fig. 10** Calcaroni

**Fig. 11** Four-chamber Gill's furnace



**Sanfilippo's ore roasting furnaces** were invented by Ignazio Sanfilippo, owner of sulphur mines in Casteltermini and General Technical Director of all the mines of the Société Générale des Soufres, Ignazio Florio's company operating in the sulphur industry. Sanfilippo invented a new furnace in 1901 which was patented in 1902 (Fig. 12).

In 1903, Sanfilippo invented a second and more advanced type of filtering pipe furnace, which was tested and used in numerous Sicilian mines.

Sanfilippo's furnaces were suitable for any kind of sulphur metallurgical treatment, but its speciality was that of being the only one, at that time, which could melt the sulphur still contained in the industrial waste ("ginisi") after fusion had been performed in "calcaroni" and Gill's furnaces.

Furthermore, Sanfilippo's furnace could be used for melting without any special preparation of the sulphur contained in the minute crude ore ("sterri"), which could not be efficiently treated in Gill's furnaces (Fig. 13).

"Sterri" and "ginisi" were still rich in residual sulphur, but were considered industrial waste and piled up in massive mounds, up to 40 m high, having the form of cones with cut apexes. The new invention produced the great advantage of extracting the significant percentage of sulphur still contained in the huge piles of ore at no extraction cost, since it was already at ground level. In addition, the new invention reduced the big industrial problem of finding additional land on which to store the waste (Ferrara 2012).

Sanfilippo's furnaces were adopted in some of the largest Sicilian mines and became one of the most popular systems for melting sulphur. It was calculated that, in 1905, 52 Sanfilippo's fusion chambers were operating in Sicily, with a total production of 4304 tons of sulphur.

At the end of the 19th century, several mines adopted **Steam furnaces**, which had the advantages of reducing the high cost of the Gill's and Sanfilippo's furnaces,

*Forno a canali filtranti sistema "Sanfilippo"  
 pel trattamento degli sterri di minerale solfifero*

Tav. V

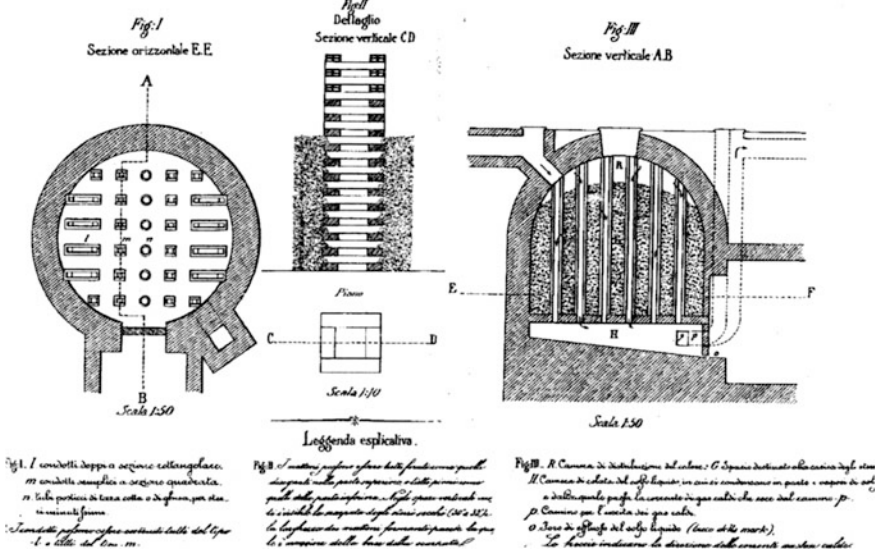


Fig. 12 Sanfilippo's filtering pipes furnace

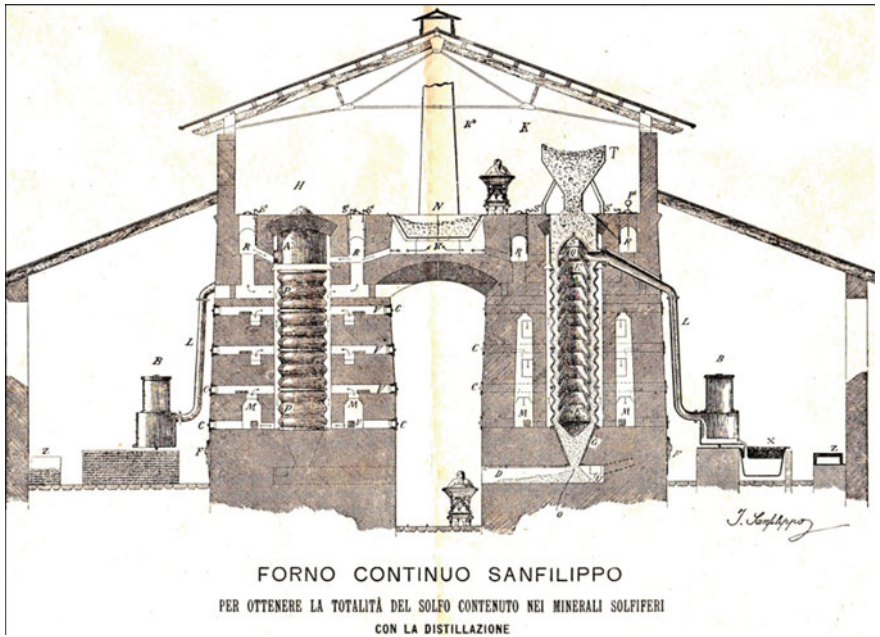


Fig. 13 Sanfilippo's ore roasting furnace

producing an excellent quality of sulphur, and having a very fast process. However, the disadvantage was the high loss of sulphur, calculated between 7 and 17 %, which made this device unsuitable for ore with a low content of sulphur.

After World War II, a higher grade of purity (99 %) of sulphur was obtained with the **Flotation process**, adopted only in a few large mines. But this attempt to modernize the industry came too late, when Sicilian sulphur was no longer competitive, and some mines never recovered from the high cost of this investment.

## 6 The Herman Frasch Process and the End of the Sicilian World Sulphur Monopoly

In December 1894, Herman Frasch, an American chemist of German origin, invented a new revolutionary technology for the extraction of sulphur from rich deposits in Louisiana and Texas. This process consisted of melting the sulphur while still deep in the ground by pumping in water heated to a temperature of above 119 °C, the fusion grade of sulphur, and then forcing the liquid sulphur up to the surface using compressed air (Fig. 14).

This hot-water sulphur mining process, after various attempts, was perfected and put into operation by the Union Sulphur Company—of which Herman Frasch was director—in 1906, in Louisiana and then in Texas.

For geological reasons, this new technology was not applicable to the Sicilian deposits. In 1898, Herman Frasch himself secretly tried his process in Porto Empedocle (AG). The attempt failed twice, confirming that his invention would have soon destroyed the Sicilian sulphur monopoly.

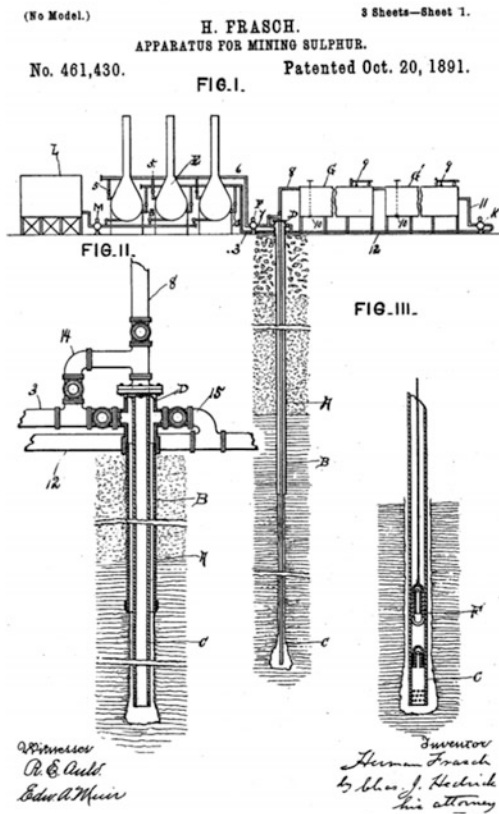
It goes without saying that the Frasch processed sulphur was produced at a very competitive cost and, in fact, it was sold at \$7.72 (US) a ton, less than half the price of the best Sicilian sulphur. Furthermore, the American sulphur was 99.5 % pure, as the melting process removed all types of impurities. In 1904, when American-produced sulphur entered the European market, the Anglo-Sicilian Company decided not to renew its contracts, and over one hundred Sicilian mines had to close.

Hardly any Sicilian sulphur was exported to the U.S., whilst American sulphur started being exported to some North European countries. In this competitive context, the price of sulphur continued to decline. In order to normalize the market, Italian and American authorities reached an agreement stating that two-thirds of the European market had to be left to the Sicilian producers, while only the remaining third was assigned to the American companies. The U.S. market was left open to competition. By 1914, the U.S. sulphur industry was ranking first in world production, well above Sicily.

The Sicilian sulphur monopoly was definitely over.



Fig. 14 Drawings of Herman Frasch's sulphur mining apparatus



### 7 The Cozzo Disi Sulphur Mine in Casteltermini: Project of Restoring and Transforming It into a “Museum Mine”

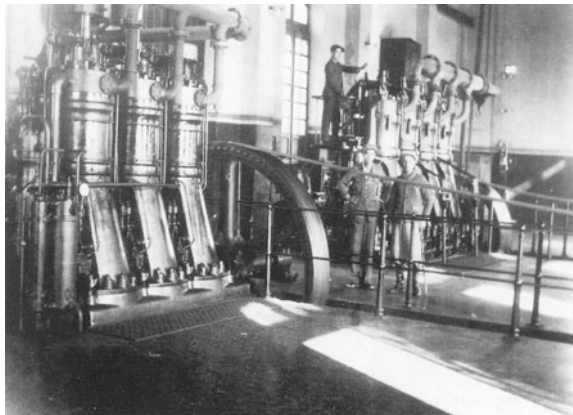
In order to fight the stiff competition from American sulphur, the largest Sicilian mine owners and “gabelloti” decided to invest the additional capital needed to modernize the production system and reduce its costs. One of the oldest sulphur mines was the Cozzo Disi located in Casteltermini.

There are records of open-air activity in this mine from the end of the 1700s and the first years of the 1800s, but proper underground extraction began in 1870 when the first galleries to the lower two levels were opened. The third level was opened in 1911 after upper levels were exhausted. From then on, extraction continued in deeper galleries, down to the 12th level. The total depth was of more than 300 m. At the beginning of the 20th century, the Cozzo Disi mine was the largest in Agrigento province and one of the most important in all of Sicily. This was due to the considerable extension of its deposits of sulphur, the purity of its ore, the absence of

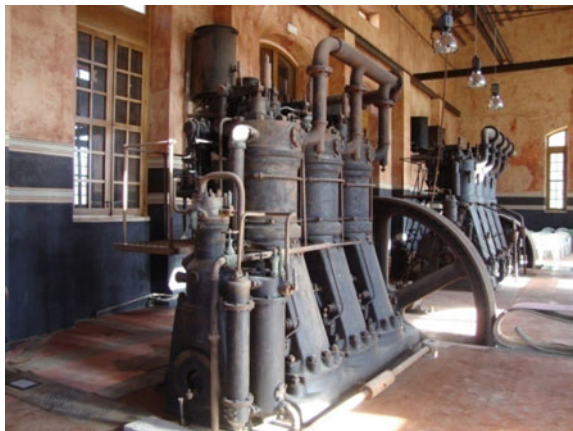
underground waters and the proximity to the railway station of Campofranco. After World War II, Cozzo Disi became one of the most important sulphur mines in Europe thanks to the installation of a modern floating system plant, which improved production considerably. However, the American sulphur competition also hit Cozzo Disi which, despite government subsidies, became unprofitable and had to start reducing its activity and number of employees. The active mining production lasted until 1988, but the mine was kept in a state of potential activity until 1991, when it was transferred to the cultural department of the Sicilian Region as a “museum mine”.

Since then, a long programme of restructuring and restoration has been ongoing with the participation of the MMS Historical Museum of the School of Engineering of Palermo University. This interesting site of industrial archaeology is expected to open to visitors in the near future (Figs. 15 and 16).

**Fig. 15** Cozzo Disi mine: old power station



**Fig. 16** Cozzo Disi mine: power station after restoration



## **8 The Role of Sulphur in the Italian Government's Decision to Colonize Libya. An Adventurous Sicilian Explorer: Ignazio Sanfilippo**

In 1911, sulphur was so important for the economy of Sicily and of all Italy that the fear of losing the world monopoly, already threatened by the Americans, was one of the causes, though minor in scale, which generated the Italo-Turkish war.

At the beginning of the 20th century, most European powers had already established one or more colonies in Northern Africa, while Italy had assured its non-interference policy in exchange for the promise that Libya, one of the last North African territories still not occupied by European states, would have been left to Italy.

At that time, the provinces of Tripolitania and Cyrenaica, later known as Libya, were under the domination of the Ottoman Empire, but their position in the Mediterranean Sea made this land a target of strategic importance to Italy. While waiting for the right time for occupation, Italy promoted a policy of “peaceful penetration” through Banco di Roma, one of the largest Italian banks at that time. The aim was to take possession of Libya gradually without having to fight for it.

For this purpose, Banco di Roma performed financial and commercial operations in Libya, such as maritime transportation, the construction of mills and an ice factory, the export of cereals, an ostrich feather industry, a sponge factory and, above all, the acquisition of land at a very high price. These operations were clearly unprofitable and generated suspicion on the part of the Ottoman Authorities about the real role of the bank. In fact, Banco di Roma had been urged to play this role by the Italian Government and under its subsidy. In other words, this was a case of private investment used as a tool of diplomacy.

Some travellers on their return to Italy from Libya had reported having seen “vast sulphur deposits” on the surface during their excursions (Giannò 1905). Should these reports have been confirmed, occupation of Libya by another country and exploitation of its sulphur deposits at a very low labour cost would have caused serious damage to the Sicilian sulphur industry and to the Italian economy in general.

It was therefore necessary to verify the information by sending an expert in sulphur research and processing for a secret exploration. The manager of the Tripoli branch of Banco di Roma—who was actually a secret agent under cover and not at all a banker—urged the Italian Foreign Ministry to take prompt action. The search for the right person was obviously done in Sicily where the largest and most important sulphur enterprise at that time was “Société Générale des Soufres”, a Sicilian-French company established in 1906 by Ignazio Florio in Paris to manage ten large mines located in the Enna, Caltanissetta and Agrigento provinces. The company employed about 7000 people and had an annual turnover of about 50,000 tons of sulphur.

The General Technical Director of the company was Ignazio Sanfilippo, co-owner and director of the sulphur mines in Casteltermini, expert in geology and

very well known in the sulphur industry, as well as for being the man behind several inventions. Ignazio Sanfilippo was then chosen to lead a dangerous secret expedition in order to verify the presence of sulphur and phosphate deposits in Tripolitania and Cyrenaica (Fig. 17).

The Sanfilippo Mission, made up of five Italians, left Tripoli on April 8, 1911, accompanied by a caravan of about seventy men and one hundred camels. The caravan included the Turkish military escort whose official task was to protect the Mission from attacks by Bedouin rebels (Ferrara 2012).

As a matter of fact, the Turkish Authorities were suspicious about the real purpose of the expedition and, therefore, the military escort had been ordered to control the Mission. For this reason, the Turkish Officer tried to impose significant restrictions on the Mission's operations, such as not allowing Sanfilippo to dig deeper than cm.20 for sample collection, limiting the length of excursions and impeding contacts with Arab chiefs. Turkish hostility and interference was partially solved by Sanfilippo, with the assistance of the Italian Consulate in Tripoli, by replacing the Turkish officer (Fig. 18).

In the meantime, diplomatic relations between Italy and Turkey had deteriorated and on September 28, 1911, the Italian Government sent the Turkish Sultan an ultimatum requesting the Ottoman Empire's consent to an Italian occupation of the Tripolitania and Cyrenaica provinces. Only 24 h later, on September 29, Italy declared war on Turkey (Del Boca 1993). The main claim contained in the ultimatum was the Ottomans' hostility to Italian enterprise in Libya, with a specific mention of the problems caused for the Italian Mineralogical Mission.

**Fig. 17** Ignazio Sanfilippo



**Fig. 18** Members of the caravan



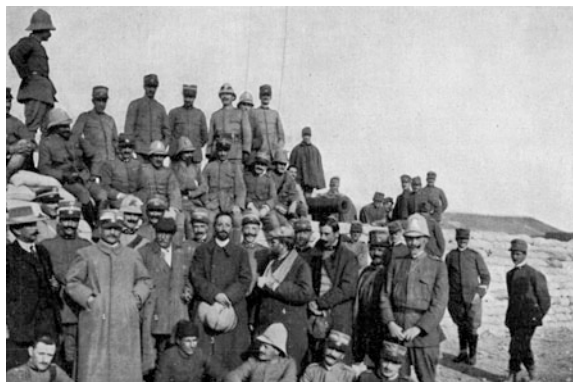
Mysteriously, neither Banco di Roma nor the Italian Consulate promptly advised the Mission of the imminent conflict (Grange 1994). As a result, the five Italian explorers had no chance to return to Tripoli and leave the country in time. They were taken prisoner by the same Turkish soldiers that had been assigned to the Mission for protection and conducted to the south of Fezzan in the Libyan desert.

The unbearable imprisonment lasted 13 months, during which time they were moved from one desert prison to another. The Italian explorers were forced to live in small dirty cells in extreme temperatures and allowed outside only a few hours a day. The food provided was extremely poor and they often had to drink water that, even after boiling, remained dirty and muddy. Any contact with Italy or with any international authority—even the International Red Cross—was strictly forbidden. Therefore, since they could not receive letters, medicine or parcels, they were in need of everything and in the dark about the political and military situation.

The Turkish soldiers considered them spies and, for that reason, constantly kept them under the threat of execution.

After lengthy negotiations, a peace treaty between Italy and Turkey was signed at Ouchy, Switzerland, on October 18, 1912, and on November 11, 1912, the Mission was finally freed (Fig. 19).

**Fig. 19** Liberation of the “Missione Sanfilippo”



Ignazio Sanfilippo received several honours, including the title of “cavaliere” of the Crown of Italy, personally presented to him by King Vittorio Emanuele III (Ferrara 2012). As soon as he returned home, he asked to be sent to Libya again to complete the exploration interrupted by the war and the imprisonment, but in the meantime, Libyan resistance had made those territories dangerous.

During the period of Fascism, other explorations confirmed that no sulphur deposits of industrial importance existed in Libya, but by then, the golden era of sulphur was already over.

## References

- Barone G (1989) Zolfare di Sicilia. In: Addamo S (ed). Sellerio, Palermo
- Cassetti M (1989) Zolfare di Sicilia. In: Addamo S (ed). Sellerio, Palermo
- De Gregorio P (1989) Economia e Società nell'area dello zolfo. S.Sciascia Editore, Caltanissetta
- Del Boca A (1993) Gli Italiani in Libia – Tripoli bel suol d'amore. Mondadori, Cles
- Ferrara V (2012) Ignazio Sanfilippo - Un Gattopardo nel Deserto. Lussografica, Caltanissetta
- Gatto M (1928) Trattamento Mineralurgico dei Minerali di Solfo. Tipografia Sociale Torinese, Torino
- Giannò S (1905) I bacini minerari della Tripolitania. Roma
- Grange JD (1994) L'Italie et la Méditerranée (1896–1911), vol II. Collection de l'École Française de Rome
- Kutney G (2007) Sulphur. History, technology, applications & industry. ChemTec Publishing, Toronto
- Musco G (1961) Lo Zolfo in Italia, atti del Convegno Nazionale dello Zolfo. Ente Zolfi Italiani, Litostampa Nomentana, Roma
- Squarzina F (1963) Produzione e commercio dello zolfo in Sicilia nel secolo XIX. ILTE, Torino

# The History of Aircraft Manufacturing at the Braşov IAR Plant

Horia Salcă and Dan Săvescu

**Abstract** This paper presents an overview of the history of the Braşov IAR Plant (Romanian Aeronautical Industry), taking into account the still unexplored sources (from public and private archives) that focus on its achievements. We can unre-servedly nominate this special factory as a “Pearl in the Crown” of the interwar Romanian industry, but—if we consider its achievements compared to the con-temporary world—it becomes apparent that it is unsurpassed in performance up until the present day by any Romanian company in the industrial field. Documents are also presented giving all the dates for the beginning of the aircraft factory at Braşov. It is good to know that, from the very beginning, it was a very good decision to build an airplane factory in Braşov, a town with a tradition of aircraft engineering. The paper presents aerial photos of the factory in 1938 and the evo-lution of products in this period (1927–1944). The factory’s exceptional achieve-ments (e.g., the IAR-80 airplane, and the IAR-7M engine) could only have occurred in a factory connected to the top performance in aviation of the time, a factory designed and built by modern principles, with a highly competent technical body. The paper also presents the symbols of the aeronautical industry in Romania and some of the engineers involved in aircraft construction at the time. The second part presents aircraft built at the Braşov IAR Plant under licence and of Romanian design, their characteristics and an addenda representing all airplanes made in the period 1924–1944.

---

H. Salcă (✉)

Spiru Haret University of Braşov, Braşov, Romania

e-mail: horia.salca@gmail.com

D. Săvescu

Transilvania University of Braşov, Braşov, Romania

e-mail: dsavescu@unitbv.ro

## 1 Human Dream of Flight, an Old Temptation

The urge to fly has been one of the most pressing human desires since the notion first occurred to us. If the wish came with the appearance of man, success only appeared after thousands of years. Beginning with birds, and the contemplation of flying, advanced by mythology, which is full of references to the idea of flying, a huge struggle was necessary for the fulfilment of a dream. Romanian fairy tales are full of kite-flying, and sometimes involve our historical legends, the winged horses of the Thracian cavaliers. Some examples of Romanian legends: master builder Manole, after completing construction of the “Curtea de Argeş” Monastery, was left on the roof by order of the ruler Neagoe Basarab (1512–1521), who feared the builder might construct another monastery, one even more beautiful. Manole made himself a pair of shingled wings, but they collapsed. In a similar story, the master builder of the Church of “Three Hierarchs” of Iaşi was left on the roof by the ruler Vasile Lupu (1634–1653); this builder also made himself a pair of wings and flew to the plain of Frumoasa (Beautiful), but there, a storm knocked him out of the sky.

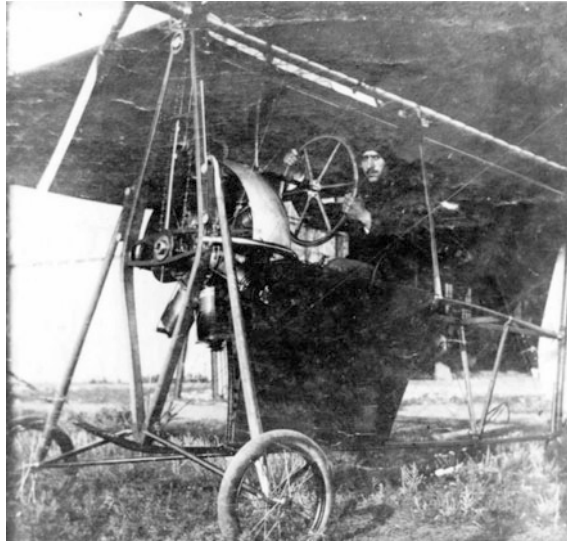
In the history of Romanian aircraft, it is necessary to mention the first flight to utilize a monoplane machine, heavier than air, with its own board instruments, realised by Traian Vuia at Montesson in 1906 (Figs. 1 and 2).

On Friday, June 4th through 17th, 1910, Aurel Vlaicu entered into the history of aeronautics with an airplane called the A. Vlaicu-1, making his first flight over Cotroceni airfield. After a number of unsuccessful attempts, he took off and flew about 50 m at a height of 3–4 m, followed by a light landing. One of Vlaicu’s hopes was to establish an air bridge between Romanians on both sides of the Carpathians, and on Saturday, September 13, 1913, he decided to make a bold attempt to realize

**Fig. 1** Traian Vuia and his first airplane (1906) (Bălan 1985)





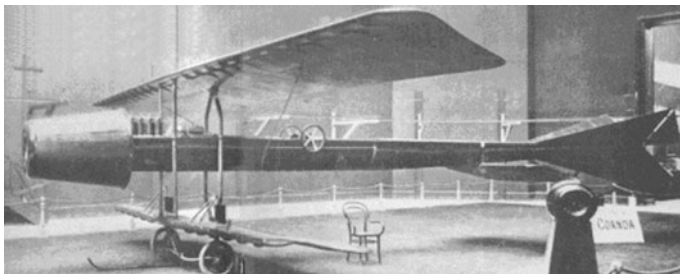


**Fig. 2** Aurel Vlaicu, June 4/17, 1910 (Bălan 1985)

this dream with a flight across that range, but unfortunately, there was a crash and he died.

With the support of the engineer Gustave Eiffel and scholar Paul Painlevé, who helped him to obtain the necessary approvals, Henri Coanda conducted preliminary aerodynamic experiments and built, in a bodywork hangar at Joachim Caproni, his first aircraft with reactive power, actually a jet plane without propellers, called conventionally the Coanda-1910. He presented this airplane to the Second International Aviation Paris Salon in 1910 (Fig. 3).

Since the establishment of the proto-space rocket by Conrad Haas, the first artificial satellite around the Earth (Sputnik I, 1957), the first spaceflight (Vostok I, April 12, 1961) to have an astronaut on board, Yuri Gagarin, the first flight around the Moon by American astronauts (Apollo 8, April 21–27, 1968), the moon landing



**Fig. 3** The first reactive airplane built by Henri Coandă (Bălan 1985)

with Neil Armstrong (Apollo 8,—July 21, 1969, at 2:56 GMT), design for space travel has meant constant struggle and the necessity for bold thinking.

In Romania, it was necessary to build a factory for aircraft and their engines, and the country's strategic position meant that many developments in international aviation materialized there between the two world wars (Negrescu 1976).

## 2 Documents and Committees at the Very Beginning (1924)



After World War I, aeronautical powers had large stocks of old aircraft made during the war that they wanted to sell. Therefore, bombers such as the Farman Goliath, Spad fighters 61 and De Havilland DH9, purchased by Romania as new aircraft, were actually old, recast and had made no minimum flight hours. The “Fokker” case, as it was called at the time, involving the purchase of a number of Fokker aircraft DXI, showed that the great aviation companies didn't respect the contractual provisions they had with countries like Romania, and the corruption and negligence that ensued at the reception of Romanian military commissions. These issues, which brought considerable financial losses to the Romanian State, strengthened the current of opinion which believed that “without a national aviation industry, we have to buy old and outdated material” (Gheorghiu 1981, 1982).

Around 1924, a good opportunity appeared in Romania: the opportunity to construct aircraft. It was established that it was necessary that 1580 aircraft be built in the subsequent 5 years. So, Romania was determined to build a plant for airplanes and aircraft engines. In order to purchase fighter and scout flyer aircraft, a technical committee was named by the authorities, composed of: Captain Commander Gheorghe Rujinski—Senior Director of Aeronautics (as Chairman), Captain Commander Constantin Beroniade—Director of the Aviation Department, Chef Engineer Gheorghe Negrescu—Aviation Arsenal Commander, and Engineer Stanislav Șeșefski—from the Technical Service of the Aviation Department. For the Reception Committee, the following men were recruited: Major in Aviation Ștefan Sănătescu, Captain in Aviation Gheorghe Bănciulescu, Engineer Michael Racoviță, Engineer Constantin Silișteanu, and Engineer Mihail Cioc, all of whom worked under coordination of the Crown Prince Carol—General Inspector in Aeronautics. The representatives from the government were: Tancred Constantinescu—the Ministry of Industry and Trade, Vintilă Brătianu—the Finance Ministry, and the

Governor of the National Bank of Romania, Mihai Oromolu. The participation of all of them, and many other personalities from the army and the civilian sector, helped boost contemporary opinion in regard to the good sense of establishing a Romanian Aeronautical Industry. We should make a special mention of Chef Engineer Ştefan Protopopescu, the head of the Technical Service of General Aeronautical Inspectorate, whom engineer Constantin Gheorghiu considered to be the true initiator of the establishment of the Braşov IAR Plant.

Because Romania intended to buy Siskin fighter aircrafts in early 1925, a technical committee went to Marthlesham Heath, where the technical service of the British Aeronautics industry was located, so as to evaluate the flight performance of this type of aircraft. Due to some incidents with the British directors, the idea of building the aircraft and an engine factory in Romania in collaboration with English factories (as was originally intended) was abandoned, and an agreement was subsequently reached with the French industry. Having established conditions, IAR entered the following factories: Lorraine-Dietrich for engines and Blériot—SPAD (“Société Anonyme Pour l’Aviation et ses Dérivés”) for aircraft. As to the choice of partners, the Romanian government representatives visited various aircraft and engine manufacturing companies, as follows: in England, de Havilland and Vickers for aircraft, Napier for engines, and Marconi for radio sets; in the Netherlands, Koolhoven and Fokker for planes; in France, Breguet, Blériot-SPAD, Farman, Nieuport and Caudron for aircraft, Scherk and CAMS for seaplanes, and Lorraine-Dietrich for engines; and in Italy, Savoia for seaplanes and Macchi for fighter airplanes.

In June of 1925, the Romanian Parliament adopted the *Law on industrial enterprises in connection with national defence*, which was promulgated by King Ferdinand I and published in the “Monitorul Oficial” (Official Gazette) no. 138/June 26, 1925. Its text was as follows (it was impossible to make a photocopy of the document):

***I, Ferdinand I,***

*By the Grace of God and the National Will, King of Romania,  
Legislative bodies passed and adopted, and we decree as follows:*

**Law on industrial enterprises in connection with national defence**

**Article 1.** *The state, represented by the Ministries of War and Industry and Trade, is authorized under order of the Ministry Council to take part in the construction of the following industrial enterprises related to national defence:*

- (a) *At the “Copşa Mică and Cugir Metallurgical Plants” for portable weapon manufacturing and also artillery weapons and ammunition;*
  - (b) *The “Romanian Aeronautical Industry—IAR” for airplane production.*
- The establishment of the first plant will be made under the rules of the commercialization law and the second setting will be made under the common law, and, keeping the general rules of the commercialization law, the State may dispense it through the formalities for authorization to operate, having the obligation to provide to the State the right to control it.*

**Article 2.** *The State will be able to guarantee the participating capital for the first enterprise of an annual dividend of 7 % for the first 10 years, and 6 % on the rest of the time, up to 40 years, and to the aircraft factory a dividend of 7 % only for the first 5 years. The State will be able to carry out some supply contracts with these countries for several years, taking the obligation only to the limits of amounts to be included in budgets and credits to be granted for this purpose, without orders to emulate power production of the respective factories.*

*The state will also give orders to the aircraft factory for a period not exceeding 10 years, taking the obligation to enroll in the department budgets the amounts needed to pay the orders of the contract. It may give to these companies the advantages of industrial law for borrowing materials, semi-finished and manufactured, only required to be installed at the factories.*

**Article 3.** *In any society in which the state is art and part, the statutes may, in derogation of the common law, provide for the shares belonging to the state, a plural voting, to provide such a necessary or agreed-upon Romanian majority.*

**Given in Sinaia, June 25, 1925, and signed by**

**King Ferdinand the 1st,**

**Tancred Constantinescu, Minister of Industry and Trade**

**G.G. Mărzescu, Minister of Justice**

**George Mărdărescu, Division General, Minister of War.**

This law was presented to the House of Representatives at its meeting on June 11, 1925, and was adopted unanimously by ninety-six votes (in 1925, the Vice President of the House of Representatives was Pompiliu Pisso, and the Secretary was Petre P. Gârboviceanu).

The law also passed during the Senate session of June 13, 1925, and was adopted by a majority of fifty-five votes against two (President, M. Pherekyde; Secretary, Sima Niculescu). King Ferdinand promulgated the law and ordered it to be invested with the seal of the State and published in the “Monitorul Oficial” (Official Gazette) (Mînzală 1995).

Ownership structure of Braşov IAR Plant in 1926

Ownership	Shares number	Shares value/lei	%
Romanian State	18,000	18,000,000	15
Industrial Credit N.S.	7250	7,250,000	6
Astra Vagoane Society	40,000	40,000,000	33.3
Lorraine Society	25,000	25,000,000	20.8
Blériot Society	15,000	15,000,000	12.5
Romanian Bank	3000	3,000,000	2.5
Marmorosch Blank&Co Bank	3000	3,000,000	2.5
Romanian Commercial Bank	2000	2,000,000	1.6
Chrissoveloni Bank	1000	1,000,000	0.8
Romanian Credit Bank	2000	2,000,000	1.6

(continued)

(continued)

Ownership	Shares number	Shares value/lei	%
Agricol Bank	1000	1,000,000	0.8
Romanian Discount Bank	1000	1,000,000	0.8
General Bank of Valachia	1000	1,000,000	0.8
Albina Bank	100	100,000	0.08
Central Bank of Cluj	350	350,000	0.29
Victoria Bank of Arad	300	300,000	0.25

After lengthy negotiations, which began on November 1, 1925, the contract was concluded for the establishment of the IAR Plant as a Limited Liability Company based in Bucharest, established with an initial capital of 120 million lei, allocated as follows:

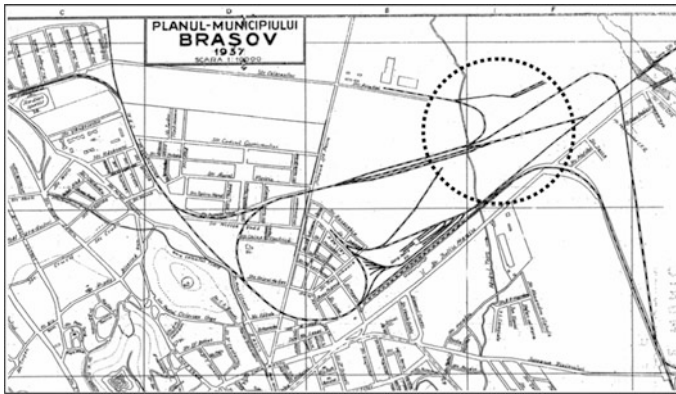
- Romanian State with a contribution of 18 million lei: 12 million representing the value of land in Braşov, where the factory and airfield construction were established, and 6 million in cash;
- 22 million lei in cash, the contribution of the Romanian Banking Group, consisting of Creditul Tehnic (Technical Loan), Banca Românească (Romanian Bank), Banca de Credit Român (Romanian Credit Bank), Banca de Scont (Discount Bank) and Banca Comercială (Commercial Bank);
- 40 million lei representing the financial contribution of “ASTRA” Vagoane (Coaches) of the Arad Company: 36 million lei, the value of the machinery and tools implemented at the Aircraft and Engines factory from Arad, transferred to IAR, and 4 million in cash;
- 40 million lei representing the financial contribution of the French Group, consisting of the Lorraine-Dietrich (for engines) and Blériot-SPAD (for airplanes) companies.

### 3 Land Position and First Products

The land on which the factory and airfield were built measured 340 yokes (approximately 2,233,700 m<sup>2</sup>). The positioning of the factory was a very good choice, being just near the railway station, which also allowed it to have internal railways.

In November 1925, the Romanian Ministry of War signed a contract with the two French companies for aircraft. At the same time, Romania began to build spare engines for products built in France until the entire installation in Braşov could be finalized. Exactly one year later, in November 1926, the Cells Plant was ready, and exactly one year after that, in November 1927, the Engines Plant was also ready to produce.

IAR received, in advance, an order for “Morane-Saulnier” school aircrafts, equipped with “Le Rhône” engines, and an order for 100 “Potez XXV” planes of observation, with Lorraine engines of 335,565 W (Fig. 4).



**Fig. 4** The Braşov map with the position of the I.A.R. Plant

In the beginning, IAR had, as general director, a French specialist, responsible for technical management, a Board and a commissioner from the government who would observe the work of the Board (Salcă 2006).

## 4 Factory Development

In February 1927, the General Inspectorate of Aviation appointed a committee, chaired by Major engineer George Negrescu and including the engineer Racoviţă and Major Bucur from the Genius Service of Aeronautics, to analyze the construction progress and determine whether the facilities were ready to begin filling orders for planes. After a careful examination of the buildings and installations, the Commission issued, on February 15, 1927, a report, which concluded that the plant could build, in the first year, only 100 aircraft, and in the coming years, could reach up to 350 planes per year. The findings prompted the ministry to issue a first order for planes at IAR Braşov—despite representations of foreign plants and their various Romanian supporters—which would consist of “Potez XXV” planes with Lorraine engines of 450 HP. The structure of IAR Braşov consisted of the main office in Bucharest, at No. 6 Anastase Simu Street, the two plants in Braşov, on the land described above, and an office in Paris (Fig. 5).

On October 11, 1927, the Braşov I.A.R. Plant was inaugurated with much fanfare at a ceremony attended by numerous representatives of the civil and military authorities from Romania and also foreign guests. Among these, we mention Ion I. C. Brătianu—Prime Minister, General P. Angheliescu—Minister of War, General Henri Berthelot—the French Government representative, Clinchant—French Ambassador in Bucharest, representatives of the French group: engineer Louis Blériot—director of the Society Blériot—SPAD, and Nicaise—Chairman of the Board of the Lorraine-Dietrich Company (engines), General Constantin Coandă—

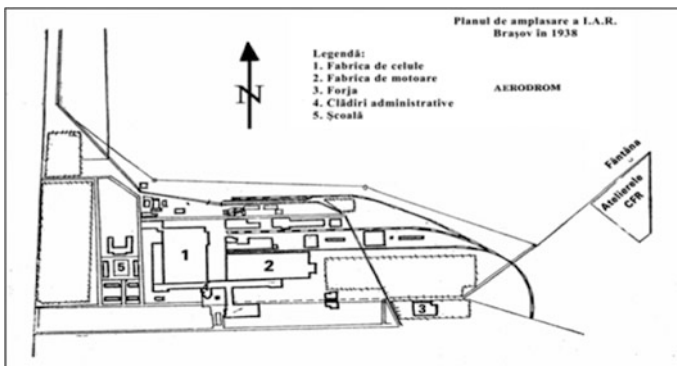


**Fig. 5** Paper consisting signatures of officials at the inauguration of the Cells Plant (Mînzală 1995)

president of the Board, generals: Rudeanu, Cantacuzino, Mircescu, Lăzărescu, Nicoleanu, many diplomats, officers and others (Fig. 6).

The important buildings are (see Legenda): (1) Fabrica de Celule (Cells Plant); (2) Fabrica de motoare (Engines Plant); (3) Forja (Forge); (4) Clădiri administrative (Administrative buildings); (5) Şcoală (School). It is very interesting to see the considerable care taken to have specialists and a school just near the plant (Fig. 7).

The design of the Assembly Hall (Cells Plant) was made by architect Grigore M. Cantacuzino and the construction of the plant was begun by a local inhabitant: engineer Tiberiu Eremie (1875–1938), born in Purcăreni, near Braşov, and educated at the Polytechnic School of Zürich. He also created buildings like: the “Union Hall” in Alba Iulia, the “Arch of Triumph” in Bucharest, the “Mausoleum” of



**Fig. 6** The Main map in 1938 (Salcă 2006)

**Fig. 7** Aerial view in 1929  
(Salcă 2006)



Mărășești, the Locomotive Factory of the Franco-Romanian society in Brăila, the Bucharest Ford Plants, etc.

Initially, two factories were built in the IAR area: the Engine factory and the Cells factory. Others were added later to build accessories during World War II, including weapons. One of the remarkable buildings, which still exists today, a vanguard realisation at the time, was the hangar with a parabolic section, opening about 60 m, with reinforced concrete arches, fixed at both ends of the bracing.

Manufacturing began with the implementation of licensed aircraft; the engines, at the beginning, were imported, the Romanian production only starting in Brașov in 1930 (Fig. 8).

The IAR factory had two major advantages from the beginning: first, the equipment and, second, the staff. Facilities were made with the most advanced machine tools, industrial machinery and equipment of the time, most acquired from the French partners, but also from Switzerland, the USA, Czechoslovakia, and later Germany and Sweden. An interesting fact is that, as a result of the self-endowment, especially in the years 1937–1939, the IAR were making original machines and aggregates, such as special machines for milling inner pistons or engine crankcase profiles. Throughout its entire existence, the IAR. was in the forefront of the Romanian industry, particularly in regard to equipment and performance. Regarding speciality personnel/staff, in the beginning, the IAR received a large group of engineers and technicians from the French companies Blériot-SPAD and

**Fig. 8** Aerial view in 1930  
(Mînzală 1995)





**Fig. 9** Polish Engineers signing documents supervised by I.V. Stalin



Lorraine-Dietrich, specialists from ASTRA Vagoane Arad (Brandenburg, Dumitru Barbieri, Ion Walner, Ştefan Urziceanu) and also young engineers who had graduated in Romania and abroad (this would become a real personnel policy of the plant, bringing the following engineers to work there: Carafoli, Crişan, Cionca, Gheorghiu, Persu, Mărdărescu, Gârnet, Cosereanu, Manicatide, Silimon). As the plant developed, the rest of the staff was recruited and further specialized.

After the occupation of Poland (in September 1939) by the German army, a lot of Polish refugees in Romania, specialists in aeronautics from Panstwowe Zakłady Lotnicze (PZL), a company with which IAR had collaborated in 1933 and who bought licenses for PZL-11F (1934) and PZL-24E (1937) aircraft, were included in the IAR Plant staff. One of these experts was engineer Witold Kasprzik, the famous manufacturer of gliders. Figure 9 shows some of the Polish engineers signing documents, under watch of a Soviet supervisor (I.V. Stalin).

In 1934, at the request of Elie Carafoli, director of the Cells Plant, construction was begun on a new hall for large airplanes (two-engine bombers, Savoia 79), which was opened in 1936.

In 1935, a project was initiated for the central administrative building, *the Casino*, located at the end of the two factories, with a view of the city. *The Casino*, composed of a ground floor and two floors above that, also consisted of a tower, which was begun in 1938. The top of the tower held a water tank, and water was pumped from its own fountain.

In 1937, it was decided, on the proposal of the Secretary of State for Air (led by Tancred Constantinescu and Ion Bastaki), that construction of the Poldi Forge would begin (information concerning this appears in the Journal of the Council of Ministers, no. 1531/July 22, 1937, signed by G. Tătărescu).

The general capital consisted of 40 million lei, and the distribution of it was as follows: 40 % to the IAR, and 60 % to the Poldihütte of Kladno Steelworks (Czechoslovakia), with a right to buy shares subscribed by Poldi in ten years.

The forge entered into service in June 1937 and was designed for a minimum annual capacity of steel forgings for 150 engines of 650 HP. It was located on a plot

of 23,800 m<sup>2</sup>, the property of IAR, and included a forge and a light alloy foundry. Management was provided by General Hentzescu and Ion Bastaki from IAR and F. Hummelberger and D. Sieber from Poldihütte. The works were not completed until December 1937. Most of the building and changes (expansions) performed after 1936 were made under the auspice of engineer and architect W. Schmitts and engineer C. Nicolau, both from Braşov. During 1937–1938, workshops were conducted by the prestigious architect Octav Doicescu (1902–1981), who designed, among other things, the halls of Colibaşi (1943–1944) and the Polytechnic Institute of Bucharest (1967). On October 28, 1938, the IAR limited company transformed from an autonomous state into a company under the direct leadership the Ministry of Air and Navy, led by General Paul Teodorescu. On this occasion, management was transferred to a steering committee comprised of General Engineer Gheorghe Negrescu, General Constantin Beroniade and engineer Aurel Persu, the latter of whom was general manager of IAR. The beginning of the war determined that all production would turn to fighter and scout flyer aircraft (Fig. 10).

At the proposal of the Air Undersecretary of State, Marshal Ion Antonescu, the IAR extension was approved in 1942, with two new factories: one for engines at Colibaşi-Pitesti and one for airscrew at Câmpulung. The Engines plant in Colibaşi was designed by a group of the Ministry of Construction, led by architect Octav Doicescu in cooperation with representatives from the Ministry of War. The IAR factory was sized to an output of 600 engines per month. The six halls, 5000 m<sup>2</sup> each, with a 20 m opening structure, were scattered in the forest, and it was covered with camouflage netting so that the plane would seem plain. The building work was completed in 1945. At the end of the war, they were taken over by Căile (Figs. 11 and 12). Ferate Române (Romanian Railways), later generating the Dacia plants. The airscrew plant at Câmpulung was installed in a former paper mill, refurbished and properly equipped. And, as it turned out, it would represent the future of our industry, creating the enterprise of ARO Câmpulung. However nothing was invested in expanding the plant in Braşov after 1942, when plans for dispersion were drawn up and submitted to the ruler at that time, Marshal Ion Antonescu.



**Fig. 10** The first aircraft in front of the hangar of the Cells Plant (Salcă 2006)

**Fig. 11** Two symbols of IAR: the main gate and the basorelief realized by C. Baraschi (Salcă 2006)



**Fig. 12** Some specialists from the IAR Plant in the early days (Oroveanu 1981)



## 5 Airplanes Built Under License at I.A.R.

The first types of aircraft built at the Braşov IAR Plant were under French license, like the Morane—Saulnier MS-35, an airplane with two-seats, the Morane-Saulnier MS-35 series, and a mono-plane with the wing above and an air-cooled rotary engine with an output of 80 HP, the Gnôme-Rhône type. Thirty aircraft were made up until 1927. The production at the Braşov IAR Plant continued with the Potez XXY, a biplane aircraft, under French license. 250 Potez XXY types were constructed, the manufacture beginning in 1929, followed, in 1934, by a series of 220 aircraft monoplanes, type Fleet—10G, having the wing up under American licence. In parallel, in 1930, the first airplane designed in Braşov appeared, the IAR 11-CV, the pioneer in the Romanian aircraft industry.

Production continued with airplanes under Polish licence, the PZL-11F type in 1934, the PZL-24 in 1935, and the PZL-24E starting in 1937. Production was followed by airplanes under Italian license, the Savoia Marchetti S-62 type in 1936, the JRS-79B in 1940, and the Nardi FN-305 in 1939. It is valuable to know that the Savoia Marchetti S-62 was a seaplane-based aircraft assembled at Constanţa, Romania. Following the Italian-licensed planes, the Fiesler Fi-156 Storch, under German license, was built in 1942, as was the competitive, high performance airplane, the Messerschmitt Me-109G, in 1944 (Gheorghiu 1981, 1982).

## 6 Airplanes Conceived at Braşov

Between 1930 and 1940, the specialists of IAR designed and developed 15 types of aircraft, the most advanced being the IAR-80 fighter aircraft and its derivative, the IAR-81 bomber, only 480 units of which were produced. After the first flight of a plane of its own design, more followed, including the IAR CV-11, designed by engineers Elie Carafoli and Lucien Virmoux (on a team which included Ion Grosu, Ştefan Urziceanu, Dumitru Barbieri, Vladimir Timoshenko, Ion Ciobanu and Ion Coşereanu), followed by aircraft types IAR-12, IAR -13, IAR-14, IAR-15, IAR-16, IAR-21, IAR-22, IAR-23, and later, in 1939, the IAR-80. The IAR-80 had variants, called the IAR-80A and IAR -80B, and derivative IAR-81 bomber variants, the IAR-81A, IAR-81B and IAR-81C (Gheorghiu 1981, 1982).

## 7 The Performing Aircraft I.A.R.-80

There can be no doubt that the IAR-80 was the best autochthon aircraft of all time and one with the finest performance in World War II, comparable, according to some specialists, in performance with the Messerschmitt Me-109G (Germany, 520 km/h), the Hawker-Hurricane (Great Britain, 570 km/h) and the Curtiss-Wright P-37 (USA, 550 km/h), ranking, in terms of speed, in fourth place after the

mentioned aircraft with 510 km/h, although some sources said that one of the improved variants reached 550 km/h. The design of this model began in late 1937 and was led by the engineer Ion Grosu, aimed at achieving a fighter aircraft of high performance at a time when the Polish PZL fighter was out of performance. The design team was composed of: Ion Grosu, Ion Coşereanu, Gheorghe Zotta, Radu Manicaticide and Ion Wallner. Since the model had outstanding performance in terms of speed and manoeuvrability, it was decided to move it into mass production.

The first test flight took place in 1938 and in early 1939, and was made by a test pilot, Dumitru (Pufi) Popescu. The hunting version was named the IAR-80, and a variable derived for bombing dives, with a locking system for bombs at the bottom, was called the IAR-81. In terms of construction, the IAR-80 aircraft was a monoplane, single seat and single engine, sleek lines, metallic wing of the “Gull” variety, a retractable undercarriage, a panoramic cabin with a sliding Plexiglass dome, a triple airscrew with variable pitch control, and a performing engine. It was the IAR 1000 A, K-14, manufactured in Braşov, that had 1040 HP developed by the engine. Other performance factors should be mentioned: high ceiling (10,500 m) and maximum speed of 510 km/h. Preparation for manufacturing was from October 1937 to February 1939, and approval took place in 1939. The equipment used was overwhelmingly Romanian. Many of the original solutions introduced by engineer Mircea Grosu-Viziru were subsequently taken over from the German’s aircrafts, e.g., from the Focke-Wulf 190 D9. The IAR-80 was manufactured and furnished for the Romanian army between spring 1942 and 1944, when production was replaced by the Messerschmitt Bf 109 G’s under a German license. Figures 14 and 15 show photos of the IAR-80 airplanes (Fig. 13) (Antoniu 1991).

Airplanes built under licence at Braşov IAR Plant. Characteristics

Aircraft type	Year	Licence Origin	Power (HP)	Altitude (m)	Speed (km/h)	Weight (kg)	Scale (m)	Length (m)	Height (m)
Morane-Saulnier	1927	France	80	4600	135	700	10.57	6.77	3.61
Potez XXT	1929	France	450	700	217	1960	14.10	9.20	3.64
PZL-11F	1934	Poland	600	10,000	300	1108	10.72	7.56	2.90
Fleet F-10G	1936	USA	130	3600	185	530	8.53	7.29	2.50
Savoia Marchetti	1936	Italy	750	4500	218	4150	16.66	12.26	4.19
PZL-24E	1937	Poland	870	10,500	430	1775	10.71	7.50	2.60
Nardi FN-305	1937	Italy	180	5000	300	858	8.47	7.13	2.15
Savoia Marchetti	1940	Italy	1200	7000	350	12,000	21.20	16.82	5.53
Fiesler Storch	1942	Germany	240	5090	175	930	14.25	9.75	3.76
Messerschmitt Me-109G	1944	Germany	1475	11,800	615	3400	9.92	8.85	3.20

Airplanes built at IAR Plant in Romanian design. Characteristics

Aircraft type	Power (HP)	Altitude (m)	Weight (kg)	Wings (m)	Length (m)	Height (m)	Maximum Speed (km/h)	Year
IAR-11	600	9000	1510	11.50	6.98	2.46	329	1930
IAR-12	450	7500	1540	11.70	7.32	2.50	294	1932
IAR-13	450	7500	1540	11.70	7.32	2.50	294	1933
IAR-14	450	7500	1540	11.70	7.32	2.50	294	1933
IAR-15	600	10,000	1707	11.00	8.29	2.70	351	1933
IAR-16	500	10,000	1650	11.70	7.37	2.80	342	1934
IAR-21	120	5500	850	12.00	7.00	2.50	190	1933
IAR-22	130	5000	880	11.53	7.50	2.02	193	1934
IAR-23	340	4100	1920	12.00	8.35	2.70	245	1934
IAR-24	350	4500	2030	12.00	8.35	2.70	280	1935
IAR-27	180	5000	948	9.10	7.41	2.40	180	1937
IAR-37	870	8000	3459	12.22	9.50	3.97	335	1937
IAR-38	700	7000	3100	13.20	9.56	3.80	220	1938
IAR-39	870	8000	3085	13.10	9.60	3.99	336	1939
IAR-80	1000	10,500	2550	10.50	8.90	3.60	510	1939

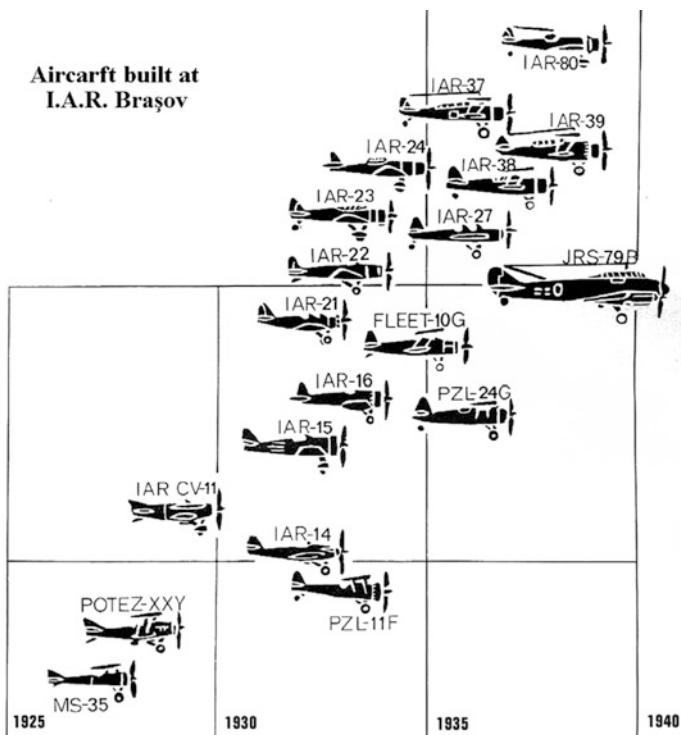


Fig. 13 Aircraft built at the Braşov IAR Plant (Salcă 2006)



**Fig. 14** Formartion of IAR-80 aircraft in flight (Gheorghiu 1981, 1982)

First, there was the campaign in the East, against the Soviet Union, in which IAR-80 aircraft fought with the Luftwaffe in noted actions against Soviet fighters and in bombing and reconnaissance missions. Then, in 1943–1944, before the massive Allied bombing of Bucharest and area refineries at Ploieşti, IAR-80 aircraft created havoc in the midst of enemy bombardment. After the Second World War, most IAR-80 were confiscated by the Soviets as “war reparations”. The joke at the time was: “Do you know Lavoisier’s principle?” And the answer was: “Nothing is lost, nothing is gained, it is transported” (Figs. 16, 17).



**Fig. 15** IAR-80 fighters (Salcă 2006)



**Fig. 16** The last survivor



**Fig. 17** IAR-80 squadron ready to fly

## **8 The Role of the Engineers of IAR in the Establishment of Higher Technical Education at Braşov**

Higher education at Braşov started in the fall of 1940, after the annexation of Northern Transylvania by Hungary following the Vienna Diktat, by transferring the site of the Academy of High Commercial and Industrial Studies from Cluj. It was initially set up in a location at No. 5 Lungă (Long) Street. The war ended in 1945, but the return of the Academy to Cluj was postponed, and in 1947, Braşov finally became an official school by an Act of March 31, maintaining that the headquarters of the Academy would be established at the Commercial “Andrei Bârseanu” School (now Building “T”). After education reform in 1948, the Institute of Forestry was established, located in the building of the Evangelical Lutheran School for Girls (now Building “S”), whose first director was Professor Emil G. Negulescu; in 1953, the name would be changed to the Forestry Institute. Also, in 1948, a group of engineers, members of the Asociația Generală a Inginerilor din România (General Association



of Engineers), AGIR, representing most of the former IAR Plant, founded the Institute of Mechanics in two buildings: one at No. 1 Postăvarul Street (now Building “N”) and one on Vlad Tepes Street (now Building “M”); the Institute’s first director was Werner Voinarovski. In 1956, the Institute of Mechanics and the Forestry Institute merged, creating the Polytechnic Institute of Braşov (HCM 1535/1956). In 1960, the Pedagogical Institute was established (the Order 3243/July 4, 1960 of the Minister of Education and Culture), located in the building at No. 1 Sadoveanu Street, near the Hotel Aro (now demolished). In 1971, by Decree no. 348/October 12, the Polytechnic Institute and the Pedagogical Institute also merged to form the University of Braşov, which, after 1989, took the name “Transilvania”. What does this section of the history of higher education at Braşov have to do with the IAR Plant at Braşov? The answer is that IAR engineers, trained in the best engineering schools in the country or in Europe, took the initiative and built in Braşov a system for extensive technical education, teachers often teaching more courses than were covered by the syllabus requirements of the study. Their role and influence were crucial to what is today the “Transilvania” University of Braşov.

## 9 Conclusions. What Has Happened Since 1944

In Romania, the 1925 initiative by King Ferdinand I and some very capable members of government began the country’s Aeronautical Industry. The beginning was difficult, but things got better after the wise decision to build a factory in Braşov, in the middle of the country.

Specialists involved in the aircraft industry were engineers with good training, some of whom had studied at universities in Western Europe, with a consistent tradition.

In the short history (1927–1944) of Braşov, many high performance aircraft and engines were built.

As is known, Romania was conquered by the Russians after WWII, and proceeded to destroy the industry involved in war products. This began with the IAR Factory, which was transformed into the tractor factory, while another portion of it became a ball bearings factory; in Câmpulung Muscel, the factory was transformed into an automotive ARO Factory, while at Cugir, production was changed to sewing machines a.s.o (Fig. 18).



**Fig. 18** The Braşov IAR Plant after the April 16, 1944 bombardment (Gheorghiu 1981, 1982)

Nowadays, just near Braşov, there exists a helicopter factory, ICA Ghimbav, developed with our French friends, and another factory in Craiova, which specializes in hunting aircraft of small dimensions, such as the IAR-99 Şoim, and is also dedicated to schooling and training. In 1982, in Bucharest, the single aircraft for passengers ROMBAC 1-11, English licence BAC 1-11, was built, having its first flight on March 23, 1983, from Bucharest to London.

The Braşov IAR Plant was destroyed by American bombs on April 16, 1944, Easter Day of that year.

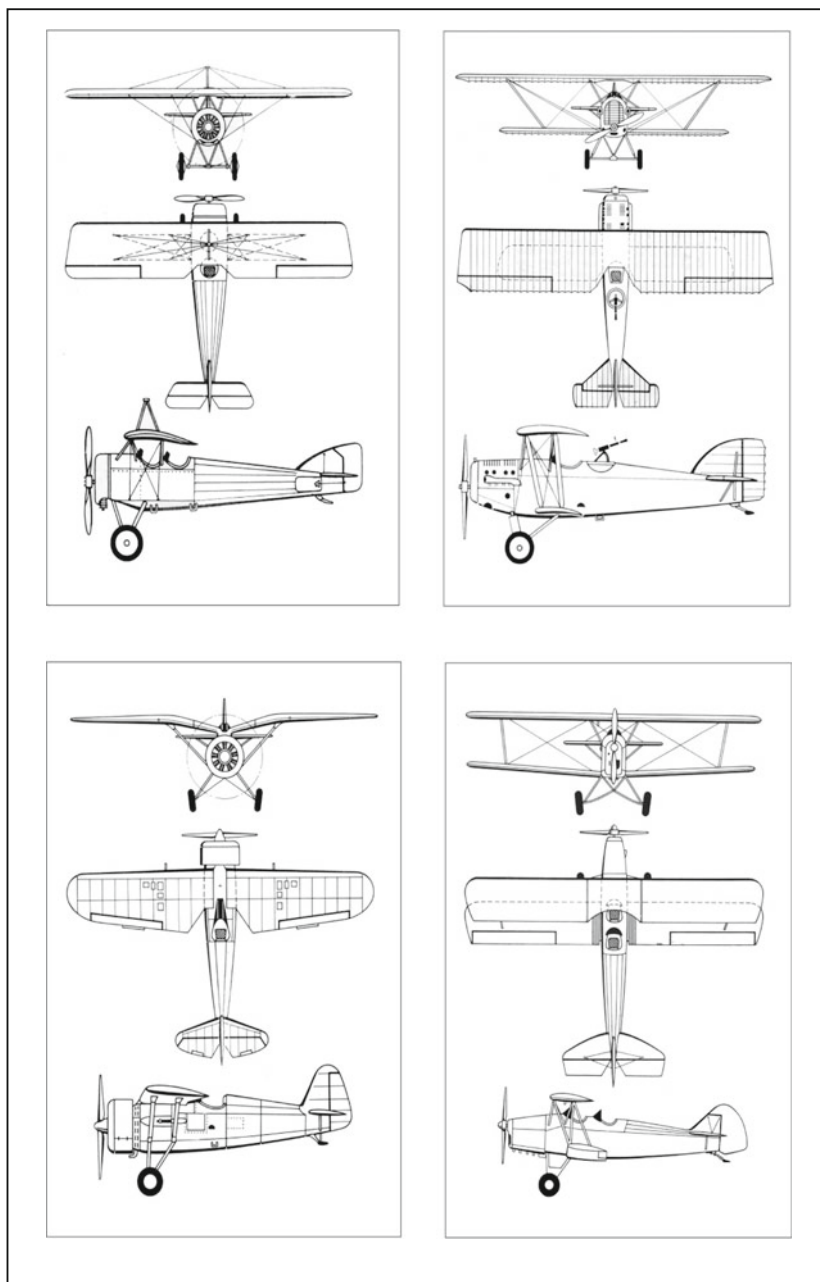
At Braşov, airplanes were first built under licence, and after that, taking into account the engineering support of inventors from the “Airplane School of Braşov”, airplanes were also designed there, including the IAR-80, which, as mentioned above, some believe ranks fourth in performance after the Messerschmitt Me-109G, the Hawker-Hurricane and the Curtiss-Wright P-37.

A lot of important engineers from IAR Braşov helped to realize the basis of the Politechnic Institute of Braşov as teaching professors. We recall here, in alphabetical order, the most important IAR engineers who went to university, with the subject/subjects taught specified: Mircea Bornemisa (Mathematical Analysis, Combustion and Heat Transfer, Heat Treatment and Furnaces), Iulian Cazacu (Casting Technology), Ion Cosereanu (Strength of Materials), Mircea Cristea (Electrical Engineering), Silviu Crisan (Machine Tools and Manufacturing Engineering) Gorun Kassargian (Thermodynamics, Heat Treatment), Vicenz Konradt (Foundry Equipment), Walter Leonhardt (Engines), Radu-Emil Mărdărescu (Engines, Automobile), Gheorghe Munteanu (Theoretical Mechanics), Emil Raţiu (Analytic Geometry, Lifting Machines, Hydraulic), Themistocle Redlov (Mechanics, Strength of Materials), Leopold Sauer (Cutting Tools), Enric Silianu (Theory of Mechanisms and Machines), Iosif Şilimon (Parts of Machines, Lifting Machines), Ovidiu Vătăşan (Metal Technology), Werner Voinarovski (first director) Constantin Wanyorek (Technology Metallurgical Processes), Zbigniew Winogrodzki (Machining Cutting). Having contributed to the advancement of high performance plants, these engineers have also contributed to the setting up and defining of the development of Braşov University.

### Addenda

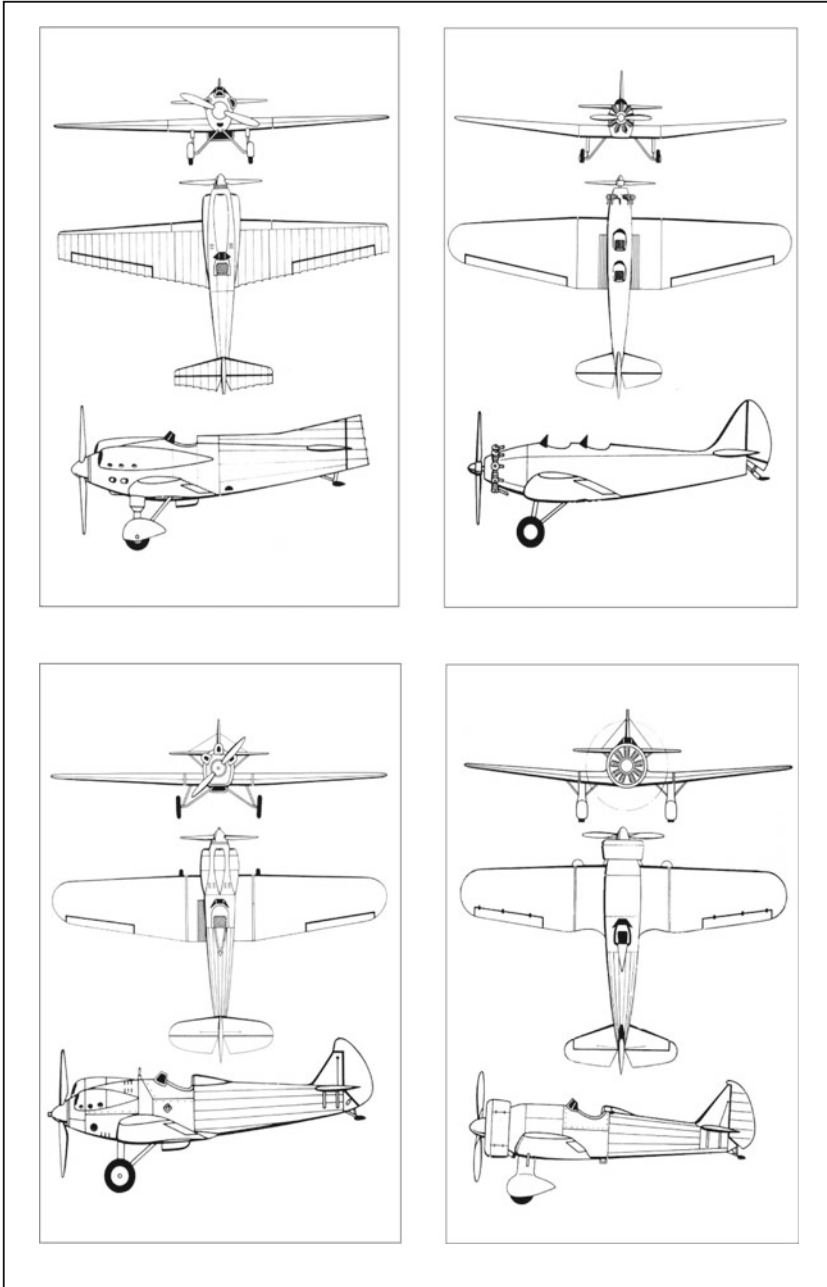
Airplanes produced at the Braşov IAR Plant in the period 1925–1944

<b>a</b> —Morane Saulnier MS 35	<b>h</b> —Fiesler Fi-156 Storch	<b>o</b> —IAR-22
<b>b</b> —Potez XXV	<b>i</b> —IAR CV-11	<b>p</b> —IAR-23
<b>c</b> —PLZ 11F	<b>j</b> —IAR-12	<b>r</b> —IAR-24
<b>d</b> —Fleet F-10G	<b>k</b> —IAR-14	<b>s</b> —IAR-27
<b>e</b> —Savoia Marchetti S-62 bis	<b>l</b> —IAR-15	<b>t</b> —IAR-37
<b>f</b> —Nardi FN-305	<b>m</b> —IAR-16	<b>u</b> —IAR-38
<b>g</b> —Savoia Marchetti JRS-79B	<b>n</b> —IAR-21	<b>v</b> —IAR-39
		<b>x</b> —IAR-80/81



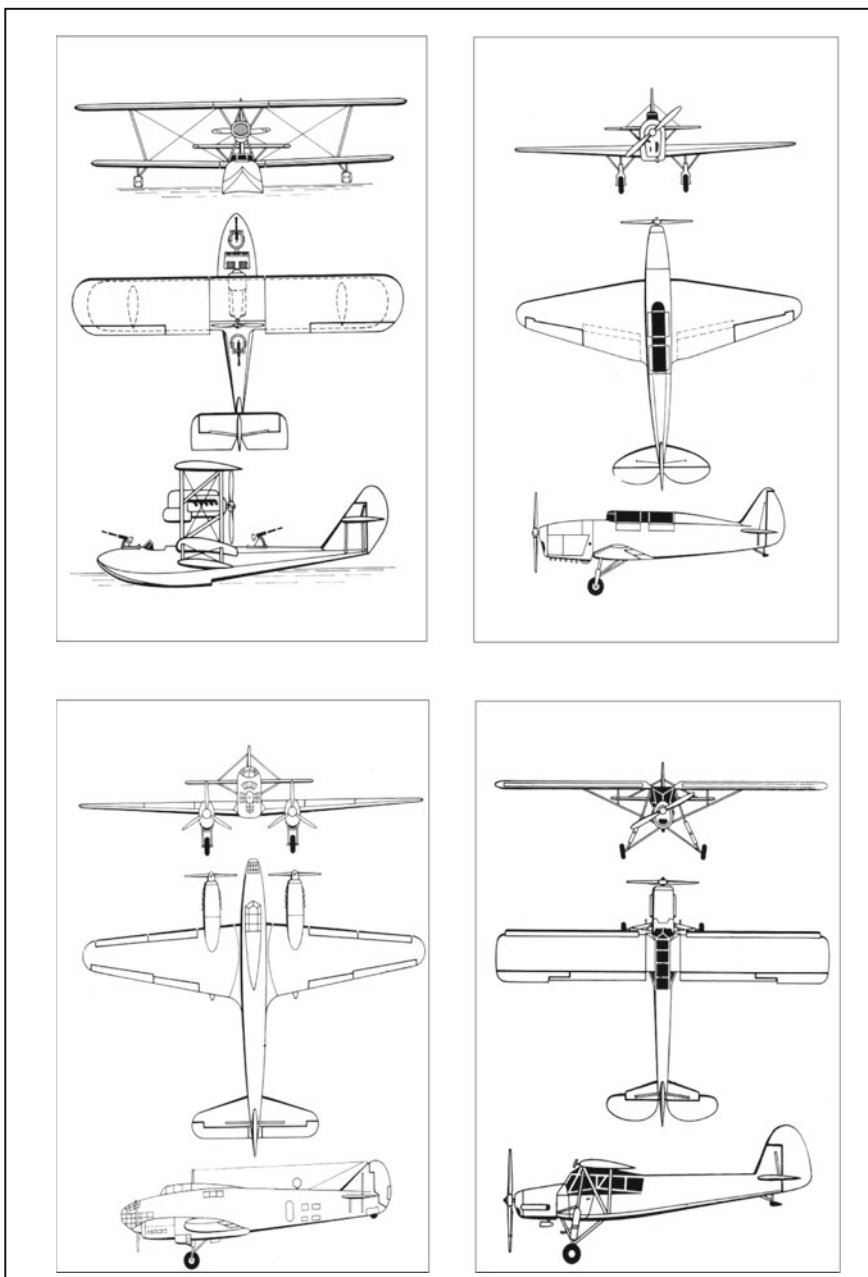
a, b – first line

c, d – second line



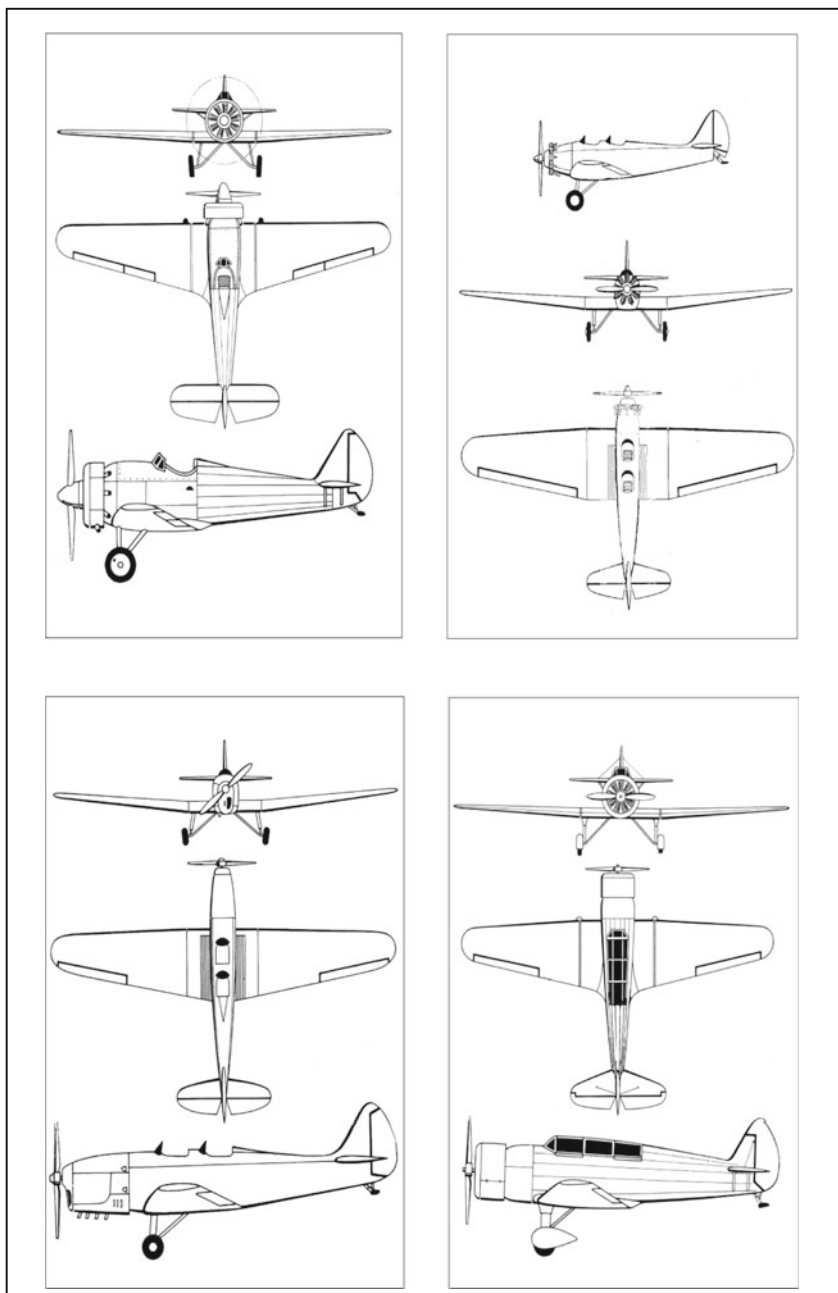
e, f – first line

g, h – second line



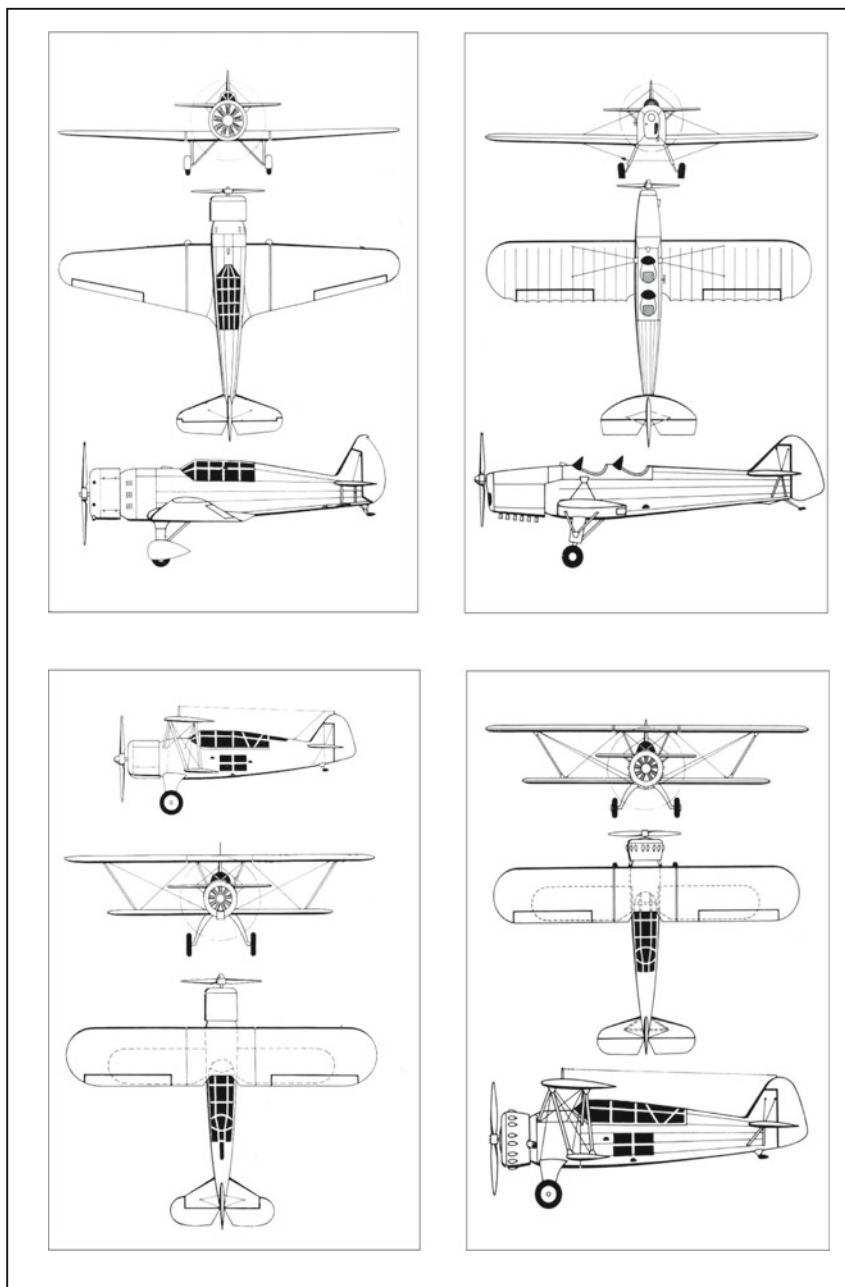
**i, j – first line**

**k, l – second line**



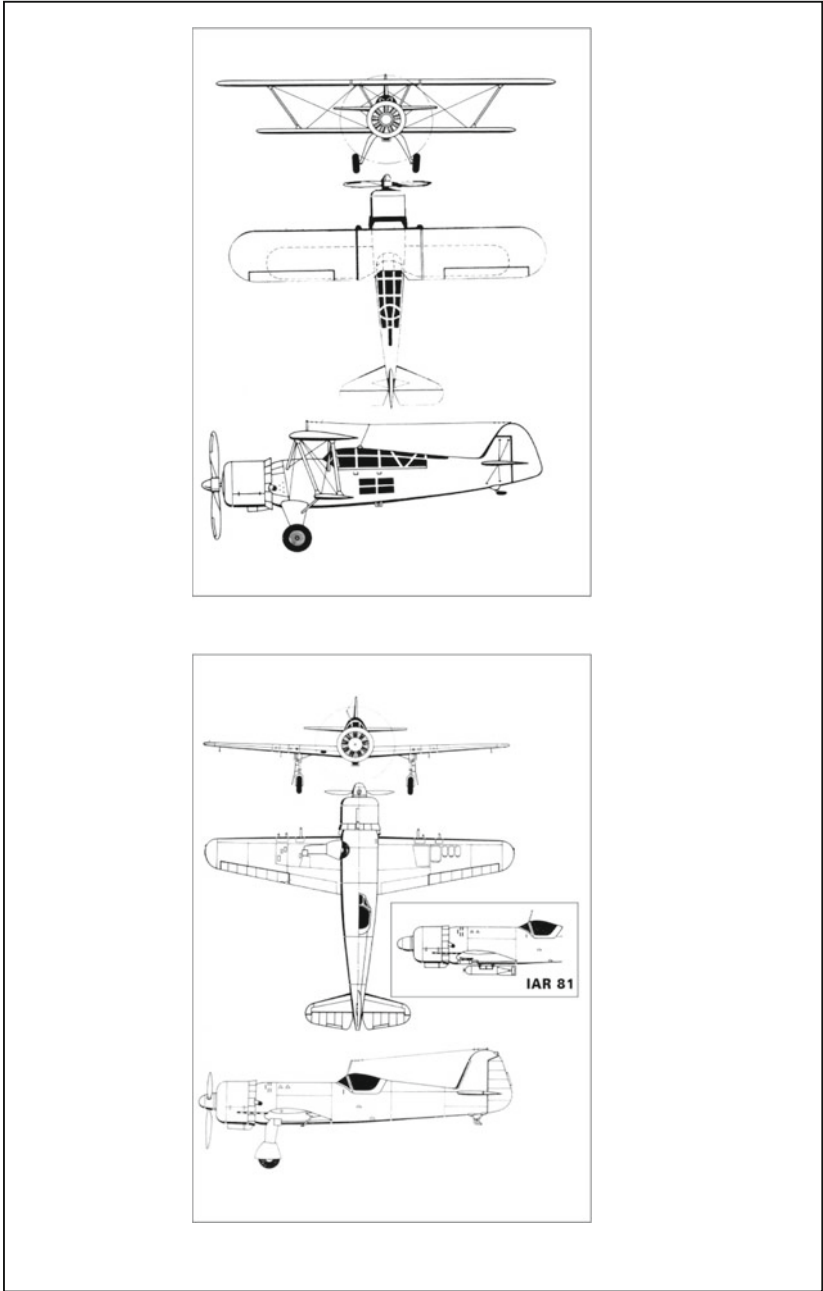
**m, n – first line**

**o, p – second line**



r, s – first line

t, u – second line



v – on the top

x – on the bottom



## References

- Antoniou D (1991) *De la IAR CV-11 la IAR-99*, în “Aeronautica”, nr. 1-2/1991, revistă magazin a Muzeului Aviaţiei, Bucureşti
- Bălan Ş (1985) Mihăilescu Nicolae – Istoria ştiinţei şi tehnicii în România. Date cronologice, Editura Academiei, Bucureşti
- Dénes B (1999) Romanian Air Force. The prime Decade, 1938–1947, Squadron/Signal Publications, Carrollton, Texas, USA
- Gheorghiu CC (1981) Zăgănescu, Florin – Din istoria industriei româneşti. Aviaţia, Editura Tehnică, Bucureşti, pp 14–73
- Gheorghiu CC (1982) Fabricile de avioane româneşti în perioada interbelică, Editura Tehnică, Bucureşti, pp 74–76
- Gujdu I, Iacobescu G, Ionescu O (1974) Romanian Aeronautical Constructions. 1905 – 1974. Military Publishing House, Bucharest
- <http://www.answers.com/topic/list-of-aircraft-engines>
- [http://www.enginehistory.org/featured\\_engines.htm](http://www.enginehistory.org/featured_engines.htm)
- <http://1000aircraftphotos.com/HistoryBriefs/HenschelHs123.htm>
- [http://en.wikipedia.org/wiki/Yakovlev\\_Yak-18](http://en.wikipedia.org/wiki/Yakovlev_Yak-18)
- <http://www.designation-systems.net/usmilav/engines.html>
- <http://www.ww2guide.com/engines.shtml>
- <http://www.aviation-history.com/engines/xr-7755.html>
- <http://www.aviation-history.com/engines/wr-1937.htm>
- <http://www.aviation-history.com/engines/radial.htm>
- <http://www.aviation-history.com/engines/rotary-theory.htm>
- <http://www.aviation-history.com/engines/clerget.htm>
- <http://www.aviation-history.com/engines/super.htm>
- [http://www.enginehistory.org/featured\\_engines.htm](http://www.enginehistory.org/featured_engines.htm)
- <http://www.aviation-history.com/engines/pr-2800.htm>
- <http://www.aviation-history.com/engines/rotary.htm>
- Mondey D (ed) (2003) The New Illustrated Encyclopedia of Aircraft. Greenwich Editions, London
- Negrescu G (1976) Un sfert de veac de aviaţie militară românească. Editura Militară, Bucureşti
- Oroveanu M (1981) Începuturile creaţiei aeronautice româneşti. 1880–1916. Editura Militară, Bucureşti
- Salcă H (2006) O istorie a Uzinei I. A. R. Braşov. Editura Universităţii Transilvania, Braşov, pp 101–131
- Mînzală J (1995) *70 de ani de la fondarea I.A.R.* Editura Duminiică, Braşov, pp 28–29
- Ionescu G (coord.) (1984) *Istoria aviaţiei române*, Editura Ştiinţifică şi Enciclopedică, Bucureşti, pp 206–231
- Zăgănescu F (1985) Aviaţia. Editura Ştiinţifică şi Enciclopedică, Bucureşti

# Science, Technology and Industry in Southern Italy Before the Unification

Cesare Rossi and Marco Ceccarelli

**Abstract** A review is presented on the main activities concerning Science, Technology and Industry in Southern Italy before the unification. These activities were often carried out with primacy in their fields. In the first part, a very short survey is presented on the history of the Kingdom of the Two Sicilies, which was the realm composed of Southern Italy and part of the central country. Comments are also made on the financial resources and welfare of the State. Then, the principal scientific studies, scientific agencies and main personalities are presented together, along with the technical achievements that represented primacies in that time. Then, the most important industries of the Kingdom of the two Sicilies, with prominent positions in the Italian Peninsula and throughout the rest of the world, are remembered. Both state industries (essentially the heavy industries) and private industries are remembered, the latter being mostly in the textile fields. Finally, a brief mention is made of the closing down of a great part of the industrial assets of the former Kingdom of the Two Sicilies.

## 1 Introduction

The Kingdom of the Two Sicilies, the realm composed of Southern Italy and a portion of the central part of the country, did not make a great contribution to the unification of Italy. On the contrary, that part of Italy was forced, in many respects, to join the unification after a short war between North and South and some further

---

C. Rossi (✉)

D.II University of Naples—"Federico II", Naples, Italy

e-mail: cesare.rossi@unina.it

M. Ceccarelli

DiCeM, University of Cassino and South Latium, Cassino, Italy

e-mail: ceccarelli@unicas.it

© Springer International Publishing Switzerland 2016

F. Sorge and G. Genchi (eds.), *Essays on the History of Mechanical Engineering*,

History of Mechanism and Machine Science 31,

DOI 10.1007/978-3-319-22680-4\_10

years of partisan warfare carried on in the mountain and rural areas (De Crescenzo et al. 2001; Grippo 2008). This is probably why the history of the primacy that was achieved in many fields in Southern Italy is not currently very widely known.

The main aim of this paper is to give a brief overview of the Science, Technology and Industry in Southern Italy and their primacy before the unification of Italy.



Fig. 1 The map and coat of arms of the Kingdom of the Two Sicilies

The Science, Technology and Industry of any country are not disconnected from the country itself, but tend to represent everywhere an essential outcome of the land and the whole population (including kings and statesmen) of which a country is composed. For this reason, there is considerable value in briefly summarizing some information about the territory of the Kingdom of the Two Sicilies. The Kingdom of the Two Sicilies was composed of lands in the Centre-South of the peninsula, as shown in the ancient map featured in Fig. 1.

The Kingdom of the Two Sicilies was the first Kingdom on the Italian Peninsula, since it was founded on Christmas Day of 1130 when, in the Cathedral of Palermo, with the approval of Pope Anacleto II, Ruggero II d'Altavilla was crowned king of all the lands shown in the map in Fig. 1.

Among the first kings, we must remember Federico II di Svevia (Honestaufen), who was called "Stupor Mundi" ("World's Wonder") for his many successful activities. Among these was his founding of the University of Naples on June 5th, 1224. Thus, the University of Naples, one of the world's oldest State Universities and the oldest in Italy, is now named "Federico II" after him.

In the final 126 years of the Kingdom, before the unification of Italy in 1861, it was held by the Royal Borbone delle Due Sicilie family. During this period of time, the Kingdom was prominent in many fields, such as welfare, medicine, science, technology, and industry (Acton 1961, 1968).

## 2 A Brief Survey on the Financial Resources and Welfare

Before the Unification, the financial reserves of the Kingdom were plentiful, such that social welfare in the Kingdom the Two Sicilies was considered to be the best in Italy and among the best in the world.

### 2.1 *Financial Resources*

Table 1 summarizes the financial reserves of the territories that composed Unified Italy before the unification. These data were given by the Italian Prime Minister Francesco Saverio Nitti (1900, 1903) to the Italian Parliament in 1919–1920.

It is possible to note that the Kingdom of the Two Sicilies alone held two thirds of the entire financial reserves of Italy. Moreover, the main coins circulating in the Kingdom had the exact value in silver or gold of the precious metal of which they were composed. For example, the one half ducato coin (the ducato was the monetary unit) was made up of a little more than 27 g of silver (in those days, silver was more valued than nowadays) and represented exactly that monetary value.

**Table 1** Financial reserves of the Italian States before unification

State	Millions of Italian Lire in gold
Italian name/English name	
Regno delle Due Sicile/Kingdom of the Two Sicilies	445.2
Lombardia/Lombardy	8.1
Ducato di Modena/Duke of Modena	0.4
Parma e Piacenza	1.2
Roma (1870)/Rome	35.3
Romagna, Marche e Umbria	55.3
Piemonte/Piedmont	27.0
Toscana/Tuscany	85.2
Venezia (1866)/Venice	12.7
Total	670.4

## 2.2 Social Welfare

Social welfare, being the care that a Government takes of its citizens, is the basis of almost any activity of a State. For this reason, the following examples are given of social welfare in the Kingdom of the Two Sicilies.

As opposed to what is sometimes believed, medicine and welfare were among the primacies of the Kingdom.

Some examples can be briefly summarized as follows:

- The first cost-free hospice for poor people. It was built in Naples in 1751 in order to host poor old people. Its area is 103,000 m<sup>2</sup> and the frontage is 354 m long, wider than that of the Reggia di Caserta (Caserta Royal Palace)
- The first cost-free medical care system, as first established at S. Leucio (Caserta) in 1789 and then progressively extended to the whole Kingdom
- The first housing project in Italy, as first established at S. Leucio (Caserta) in 1789
- The first anti-tubercular medical clinics in Italy in 1782
- The first psychiatric hospital in Italy (Reale Morotroffio di Aversa) in 1813
- The first Italian institute for deaf-mutes in 1835
- The largest number of orphanages, hospices, colleges, aid and welfare services in Italy
- The lowest infant mortality in Italy
- The largest number of medical doctors for the inhabitants of Italy
- The first vaccination against smallpox, obligatory in 1818 (the second pre-Italian State was the Piemonte in 1859)
- The first institution of schools for the social rehabilitation of criminals
- The first institution of support funds for widows and orphans
- The first institution of pension plans (with only 2 % deduction from salary)
- The first laws against vassalage and slavery in 1776–1831
- The lowest taxes in Europe
- The first free cemetery in Europe (Palermo)
- Cost-free assignments of government-owned fields to the peasants

In addition to the examples of primacy reported above, we must mention the social experiment carried out in San Leucio with the assignment of apartments equipped with running water and toilets to the workers in the textile industries and their families (statuto di San Leucio (o codice Leuciano 1789)).

Finally, it must be mentioned that the working day for those in the factories was 11 h long, while it was 14 h throughout most European countries and in the pre-unification Italian States.

### 3 Science

In this section, examples are given to illustrate the scientific level of the Kingdom.

One of the first aspects in regard to science involves the King himself and his own intellectual demeanor. It bears remembering that Federico II di Svevia. Federico II Honestaufen (Jesi, December 26, 1194—Fiorentino di Puglia, December 12, 1250), Duke of Swabia, Emperor of the Holy Roman Empire, King of Jerusalem and King of Southern Italy, was also called “Stupor mundi” (“Wonder of the World”), as mentioned above, for his extraordinary culture, energy, and ability. He invited many scientists, poets and artists to visit Palermo (the capital of the Kingdom in those days). He was himself an author of scientific works. Among his works, the most famous is probably the treatise “De arte venandi cum avibus” (“The Art of Hunting With Birds”), which is still considered the best treatise on falconry ever written. In Fig. 2, from top to bottom and from left to right, we see:



Fig. 2 Federico II di Svevia and “De arte venandi cum avibus”

Federico II, his ensigns, the treatise and some illustrations from the latter. There is good reason why the University of Naples is named after him.

### 3.1 *Seismology and Mineralogy*

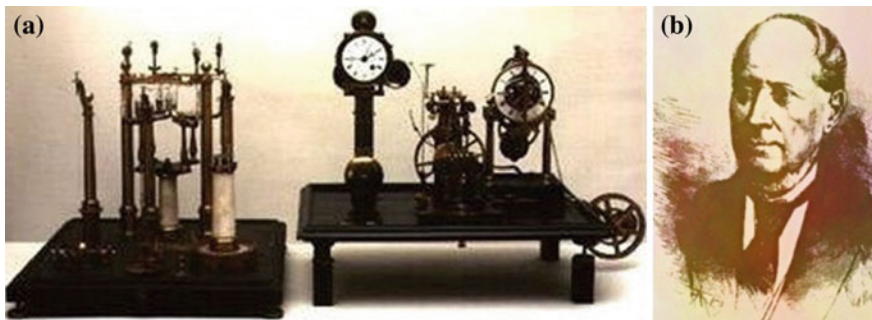
Figure 3 shows the Reale Osservatorio Vesuviano (Royal Vesuvian Observatory). It was built on the Vesuvius volcano in 1840 and represents the first Seismologic Institute in Italy.

Figure 4 shows the first electromagnetic seismograph in the world, invented and built in 1856 by Luigi Palmieri (1807–1896), who is shown in the right part of the figure.

Figure 5 shows the interiors of the first Mineralogical Museum in the world, founded in Naples in 1801.



**Fig. 3** Reale Osservatorio Vesuviano (Royal observatory of the Vesuvius)



**Fig. 4** The first electromagnetic seismograph in the world (a) and its inventor, Luigi Palmieri (b)



**Fig. 5** The first Mineralogical Museum in the world, established in Naples in 1801

### **3.2 *Cartography***

In the field of cartography, the so-called Neapolitan School was really very advanced. Figure 6 shows examples of their work. Figure 6a depicts a table from the First Maritime Code of the world, drawn by Michele Jorio in 1781. Figure 6b shows a table from the world's first maritime atlas, as drawn by Giovanni Antonio Rizzi Zannoni for Vol. 1 of the Maritime Atlas of the Two Sicilies (*Atlante Marittimo delle Due Sicilie*), published in 1792.

### **3.3 *Universities***

After its foundation as the first State University, the University of Naples “Federico II” was developed over time with prominent results. In 1754, the first Chair of Economics in the world was established there and was assigned to the famous economist Antonio Genovesi (1713, Castiglione in Salerno—1769, Napoli) (Fig. 7).

On November 18, 1808, the King of Naples Gioacchino Murat (Joachim Murat-Jordy, 1767–1815) founded the first School of Engineering in Italy at the University of Naples. It was initially named the Royal School for Bridges and Roads (*Real Scuola di ponti e strade*).



(a)



(b)



**Fig. 6** Examples of Neapolitan cartography: **a** table of maritime code drawn in 1781; **b** table from the world's first maritime atlas, as drawn in 1792

**Fig. 7** Antonio Genovesi,  
first professor of Economics  
in 1754



### **3.4 Further Scientific Primacies**

Further scientific primacies can be summarized as follows:

- The first astronomical observatory in Europe, established at Capodimonte in 1812
- The first chair of Astronomy in Italy, assigned in Naples to Pietro De Martino in 1734
- The Academy of Architecture, one of the first and most famous in Europe, established in Naples in 1802
- The first Italian Psychiatric Journal (published at the Reale Morotroffio di Aversa by Biagio Miraglia), founded in 1843
- The first modern Italian Botanical Garden (in Naples), established in 1807
- The first Italian Meteorological Observatory (at Vesuvius), established in 1839
- Archaeological excavations of Herculaneum and Pompeii, begun in 1748
- The Center for the Study of the Herculaneum Papyri, established in 1752
- The Archaeological Museum, established in 1777

## **4 Industry**

In 1856, during the World Universal Exposition in Paris, the Kingdom of the Two Sicilies was awarded as being the third country in the world to master industrialization.

In 1861, the Kingdom had about 10 million inhabitants, among whom about 3,130,000 were workers. About 1,600,000 worked in factories (the statistics are reported from a population census of Italy from 1861).

Moreover, the Kingdom owned a merchant fleet that was the second in the world to be established.

#### 4.1 *The Steelworks at Mongiana*

The largest and most important plants for the production of cast iron, iron, and steel were in Calabria at Mongiana. In Fig. 8, the location is shown on a map of southern Calabria.

The first documentation of the presence of steelworks in Calabria is dated from 1333, and again in 1523 under the rule of Carlo V d'Angiò. In 1773, the first modern steelworks were founded by order of King Carlo III. In 1840, they produced 1500 tons of cast iron. The blast furnaces were fed with coal obtained from the local oaks, which enabled the smelting of very pure cast iron. In Fig. 9, some of the remains of the plants are shown. Those plants were very advanced for their time, and, in fact, many engineers were sent to Mongiana from foreign nations to study its manufacturing process. In 1862, the steel produced at the Steelworks of Mongiana was awarded for its quality at the Industrial Exposition of London.

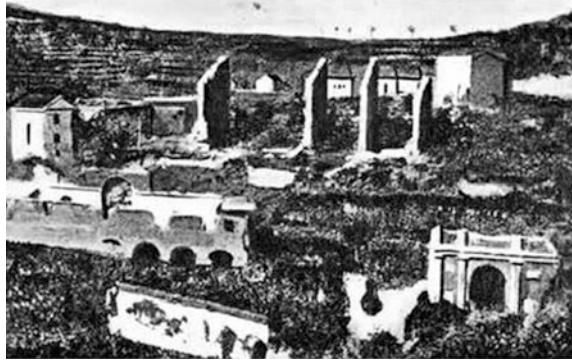
However, in the following decades, the steelworks were dismantled and closed.

The last director of the Mongiana steel mill was an engineer named Fortunato Savino (1808–1890). He made sure that all the tools and production equipment were designed and built in the homeland. He was also the founder of the Royal

**Fig. 8** Location of steelworks at Mongiana in Calabria



**Fig. 9** Remains of Mongiana's steelworks plants



Firearms Factory of Mongiana. After the unification of Italy, he became a full professor of Metallurgy at the University of Paris.

Using the iron produced in Mongiana, in 1832, the Bridge of Real Ferdinando over the river Garigliano was built. It was the first iron catenary suspension bridge in continental Europe. In Fig. 10, a technical drawing and a pictorial view of the bridge are shown.

## ***4.2 The Shipyards of Castellammare***

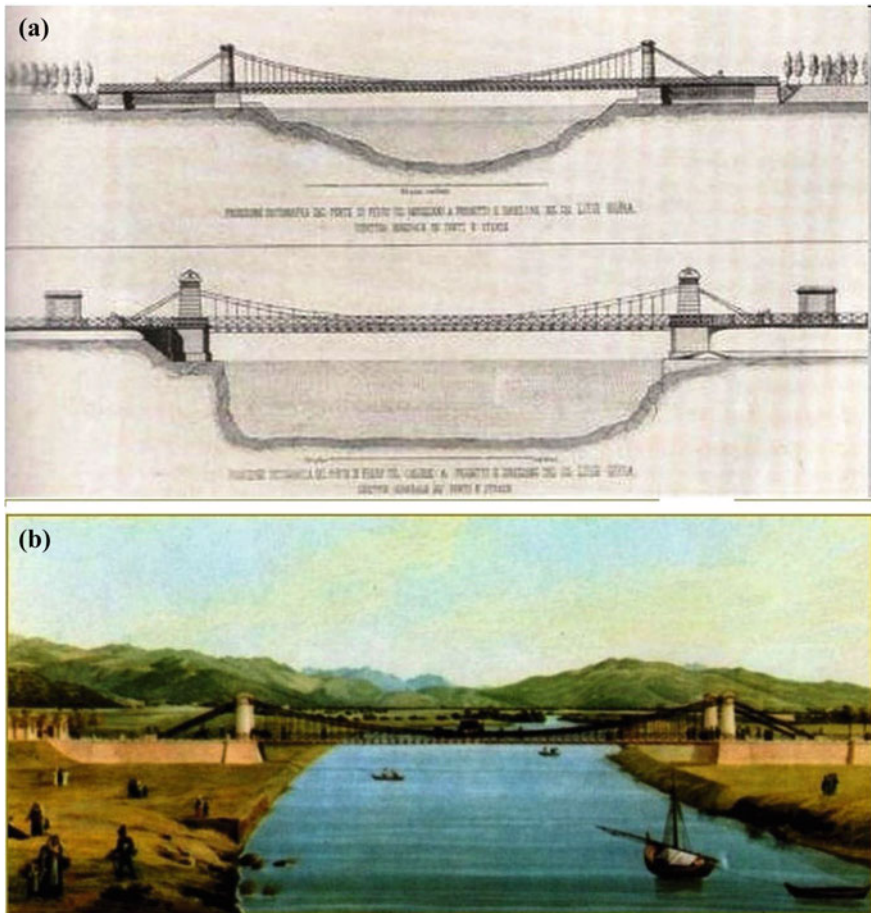
The Shipyards of Castellammare were the largest shipyards in Italy before unification, and they remained the largest for some decades afterwards. They were founded in 1783 by Guglielmo Acton by order of King Ferdinando I as the first modern shipyard in the world, employing 2000 workers. Figure 11 shows a map of the shipyards in 1839.

In 1858, the first propeller-driven Italian battleship, named the *Monarca* (Fig. 12), was built at the shipyards, and was eventually employed by the new Italian Navy as a flagship. Later, in 1931, using the design plans of this same ship, the “*Amerigo Vespucci*” was built, a vessel that is still in service as a training ship for the Italian Navy, being considered the finest training ship in the world.

For some decades after the unification of Italy, the shipyards were still very active. In fact, in 1880, at Castellammare, the *Duilio* battleship was built, considered the most powerful battleship in the world at the time.

## ***4.3 Pietrarsa Heavy Metal Works***

Pietrarsa was the first and largest heavy engineering industry in Italy (Acton 1961; De Crescenzo 2009, 2012; Morandi 1972). Its main production consisted of:

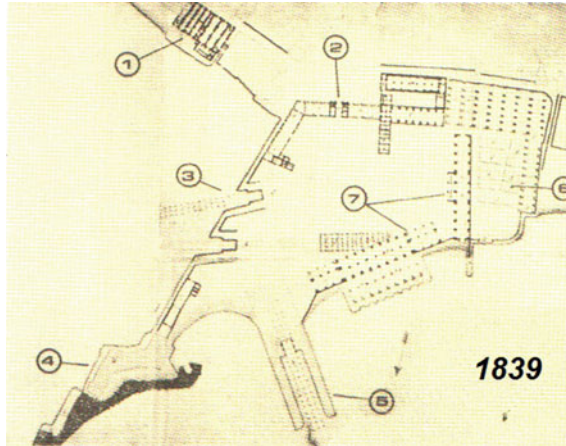


**Fig. 10** The bridge Real Ferdinando built in 1832: **a** original technical drawing; **b** a pictorial view

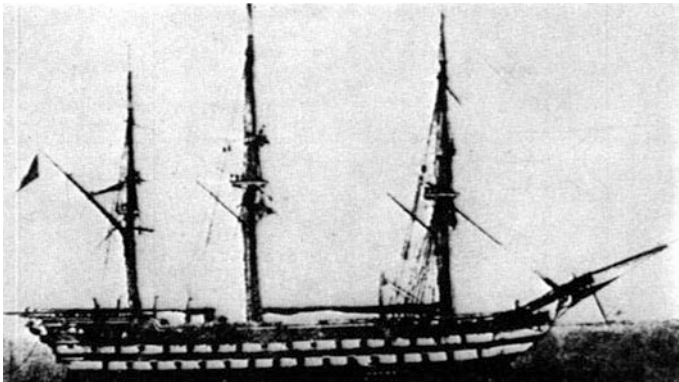
- Metal works
- Heavy machinery
- Marine propulsion systems
- Railway Locomotives

At the “Officine di Pietrarsa” (Pietrarsa Workshops), the first marine propulsion systems and the first railway locomotives in Italy were built (Giordano 1864).

In 1847, 962 workers were employed at the Workshops, including 738 civilians, 224 military; in addition to the previous, 40 inmates also were brought in for their social rehabilitation; there were also a number of managers and office workers. The presence of the inmates, expiating the last years of their imprisonment and their further rehabilitation as mechanical workers, testifies to how advanced the Kingdom was in its commitment to social welfare.



**Fig. 11** Map of the Shipyards of Castellammare in 1839

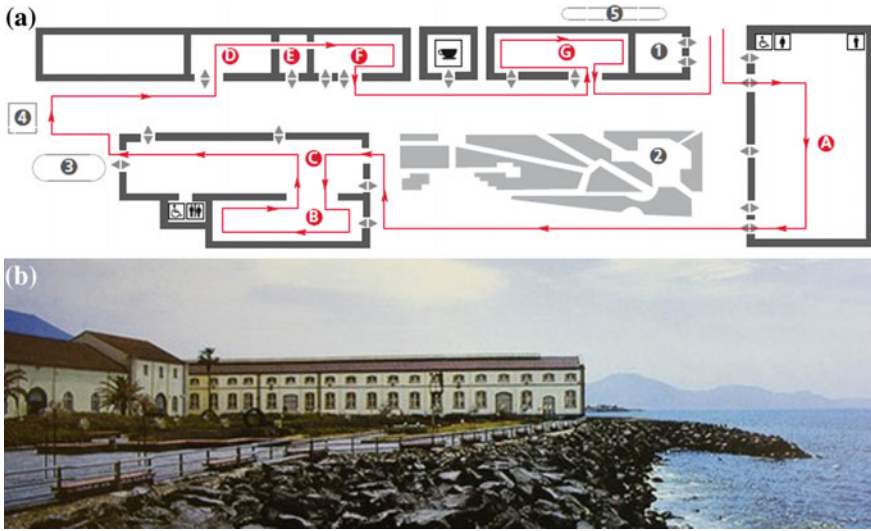


**Fig. 12** Ship 'Monarca' built in 1858

Figure 13 shows a map of the Pietrarsa Workshops and a picture of a part of the factory.

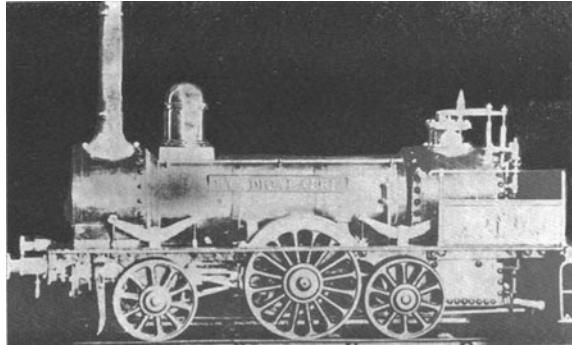
It is interesting to note that the first Italian steam locomotives were designed and built at the Pietrarsa Workshops. Figure 14 shows the "Duca di Calabria" (Duke of Calabria), the first steam locomotives designed and built in Italy, a product of the Pietrarsa Workshops in 1846.

When other Italian States decided to build railways, the trains had already been built at the Pietrarsa Workshops. In 1846, Piemonte purchased his first seven railway locomotives from the Pietrarsa Workshops, the names of which were Pietrarsa, Corsi, Robertson, Vesuvio, Maria Teresa, Etna and Partenope. Figure 15 shows a picture of the Vesuvio locomotive from a publication of the time.



**Fig. 13** Pietrarsa Workshops: **a** a map of the factory; **b** a photo view

**Fig. 14** The “Duca di Calabria” (Duke of Calabria), first steam locomotives designed and built in Italy (Pietrarsa Workshops, 1846)



After the unification of Italy, most of the heavy machine tools were transferred to Genoa; the workers who tried to oppose this were killed. By 1875, the Pietrarsa Workshops had only 100 workers. Presently, the factory buildings are used only as a museum of the Italian Railways. A brief illustrated survey of the Pietrarsa Workshops in its current museum incarnation is shown in Fig. 16.

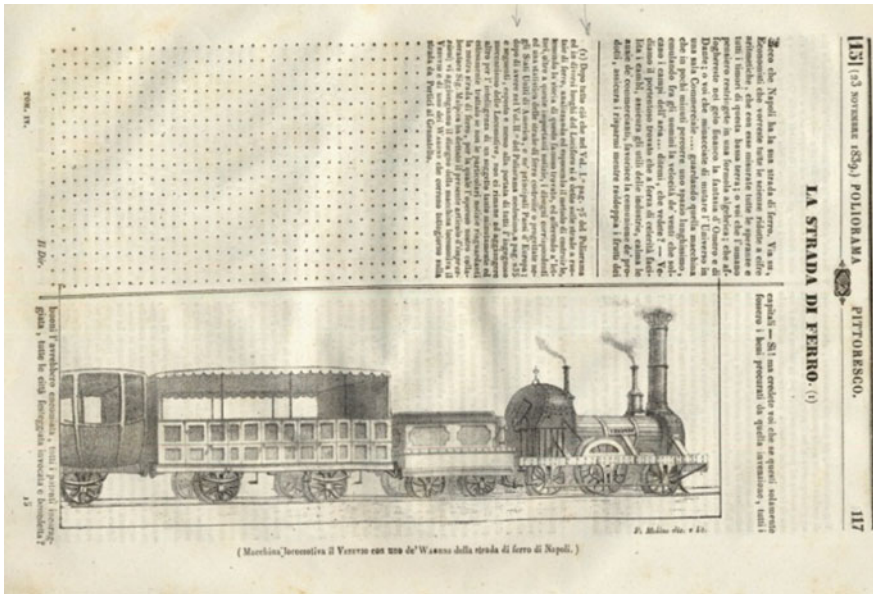


Fig. 15 The Vesuvio locomotive from a 19th century magazine

### 4.4 The Rail System

It is well-known that the first rail system in Italy was built in 1836 in the Kingdom of the Two Sicilies between Naples and Portici (1940). In Fig. 17, a painting is shown of the celebration of the event at that time.

The rail system was then extended to Salerno to the south and to Capua and Caserta to the north.

It must be remarked that the first railway tunnel in the world was also made in 1858 in the Kingdom of the Two Sicilies: it was the tunnel of the Passo dell’Orso, on the Cancellò-Avellino line, near the station of Codola (near Salerno). Figure 18 shows the inauguration of the tunnel in 1858.

Figure 19 shows a timetable of the railways in the Kingdom of the Two Sicilies in 1859, from the Giornale delle Strade Ferrate (Journal of the Railway System, May 1859). The frequency with which the trains run is remarkable for the time.

### 4.5 The Shipping Companies

In 1859, the tonnage of the merchant navy of the Kingdom of the Two Sicilies was the one of the largest in the world, second only to that of the British merchant navy and higher than that of the French (Montalto 2007, Porcaro and Cisternino1954).





**Fig. 16** Some views of the current Museum of the Italian Railways at Pietrarsa



**Fig. 17** Painting showing the first train run in Italy in 1836



**Fig. 18** Inauguration of the tunnel Passo dell'Orso in 1858 as the first railway tunnel in the world

Sicily hosted the most important shipping companies of the time, among which the following are particularly worth mentioning:

- Società Sicula Transatlantica di Salvatore De Pace (Sicilian Transatlantic Company of Salvatore De Pace), which owned the “*Sicilia*”, the first steamer to link the Mediterranean Sea with America in 1853.
- La Compagnia di Navigazione “*Florio*” (Florio Shipping Company), which established the first steamship link between Palermo and Napoli, and in 1862, the first commercial and postal shipping service along the same route.

**GIORNALE DELLE STRADE FERRATE** 749

Continuazione dell'itinerario da Roma a Napoli. — Strade ferrate Napolitane.

---

**LINEA DA NAPOLI A CASTELLAMARE TOCCANDO PORTICI TORRE DEL GRECO E TORRE ANNUNZIATA**

Partenze da Napoli		Partenze da Castellamare	
Ore	Minuti	Ore	Minuti
7	15	8	15
8	15	9	30
9	30	10	45
10	45	11	15
11	15	12	30
12	30	13	45
13	45	14	15
14	15	15	30
15	30	16	45
16	45	17	15
17	15	18	30
18	30	19	45
19	45	20	15
20	15	21	30
21	30	22	45
22	45	23	15
23	15	24	30
24	30	25	45
25	45	26	15
26	15	27	30
27	30	28	45
28	45	29	15
29	15	30	30

Prezzi per le diverse classi al per la gita come per ritorno

I. Classe		II. Classe		III. Classe		IV. Classe (per il giorno)	
D.	G.	D.	G.	D.	G.	D.	G.
15	10	10	06	06	05	05	05
30	15	15	10	10	08	08	08
45	20	20	15	15	12	12	12
60	25	25	20	20	16	16	16
75	30	30	25	25	20	20	20
90	35	35	30	30	24	24	24

Da Napoli a Portici  
 — Torre del Greco  
 — Torre Annunziata  
 — Castellamare

**DA NAPOLI A SARNO TOCCANDO CASALNUOVO, ACERRA, CANCELLO, NOLA E PALMA**

Partenze da Napoli		Partenze da Sarno	
Ore	Minuti	Ore	Minuti
6	15	7	30
7	30	8	45
8	45	9	15
9	15	10	30
10	30	11	45
11	45	12	15
12	15	13	30
13	30	14	45
14	45	15	15
15	15	16	30
16	30	17	45
17	45	18	15
18	15	19	30
19	30	20	45
20	45	21	15
21	15	22	30
22	30	23	45
23	45	24	15
24	15	25	30
25	30	26	45
26	45	27	15
27	15	28	30
28	30	29	45
29	45	30	15

Prezzi per le diverse classi al per la gita come per ritorno

I. Classe		II. Classe		III. Classe		IV. Classe (per il giorno)	
D.	G.	D.	G.	D.	G.	D.	G.
15	10	10	06	06	05	05	05
30	15	15	10	10	08	08	08
45	20	20	15	15	12	12	12
60	25	25	20	20	16	16	16
75	30	30	25	25	20	20	20
90	35	35	30	30	24	24	24

Da Napoli a Castellamare  
 — Acerra  
 — Cancelli  
 — Nola  
 — Palma  
 — Sarno

Questi due rami di strada per Capua e per Sarno tengono un unico treno da Napoli a Castellamare e la stazione in Napoli è messa fuori le mura, e precisamente all'altra per Castellamare e per Capua. N. B. Questo numero di viaggi con le strade ferrate è relativo al mese di Marzo in cui si fa maggior numero di viaggi, ma non dimanda alcuno e aliquoto accrescimento secondo la stagione e maggior lunghezza del giorno.

---

**SERVIZIO POSTALE DELLE LINEE PRINCIPALI CHE PERCORRE LA POSTA**

Per Terracina	Per Fondi	Per Formello	Per Roma	Per Campobasso
Domestica Lunedì	Domestica Lunedì	Domestica Lunedì	Domestica Lunedì	Domestica Lunedì
Martedì	Martedì	Martedì	Martedì	Martedì
Mercoledì	Mercoledì	Mercoledì	Mercoledì	Mercoledì
Giovedì	Giovedì	Giovedì	Giovedì	Giovedì
Venerdì	Venerdì	Venerdì	Venerdì	Venerdì
Sabato	Sabato	Sabato	Sabato	Sabato

---

**PREZZO DELLE CORSE**

	D.	G.
Per la corsa ogni cavallo per posta	—	—
La buona mano per postiglioni per posta	—	—
Alto stalliere per ogni coppia di cavalli	—	—
Alto stalliere della posta di Napoli soltanto	—	—
Per cavallo di ritorno che occorre da Castellamare al piano di Colto, da Castellamare alla Dirupata, e da Sarno al piano della Corona	—	—
Alloggiando i cavalli dei viaggiatori principali servono i viaggiatori sopra cavalli traversi il pagamento sarà come segue	—	—
Per la buona mano di ogni cavallo per ogni Posta	—	—
Per la buona mano al Postiglione per ogni Posta	—	—
I corrieri dell'Amministrazione Generale delle poste, e gli impiegati di qualsiasi grado che saranno spediti dall'Amministrazione medesima per servizio di servizio postale per qualsiasi servizio, la stessa somma stabilita per l'Amministrazione generale.	—	—
Per le scalfite di Reali Servizio, e dei particolari, il pagamento sarà di grana 80 a posta senza alcuna deduzione per cavalli principali o traversi.	—	—
Per cavalli di Roma il prezzo sarà per ogni posta	1	20

---

**SERVIZIO DELLE DILIGENZE**

Sono stabilite nella città tre corse di Diligence cioè:  
 Dall'albergo de' Poveri alla Villa Reale a viceversa.  
 Dalla piazza S. Ferdinando a Tribunale.  
 Dal Largo del Castello alle stazioni delle strade ferrate.  
 Ciascuna posta, nelle dette diligenze si paga grande risagio.

---

**Amministrazione delle Strade Ferrate Napolitane** — Strada Reale Vittorio n. 3 Napoli; amministrazione generale Casim. D. Tommaso de' Lepore, Largo S. Giovanni Maggiore n. 8; partenze delle Poste per via di terra, lunedì strada da Napoli a Capua ed ostacolo martedì ostacolo e ritorno da Napoli a Fondi, giovedì, Capua e Caserta; mercoledì, ostacolo, ostacolo, ostacolo, Capua e Caserta; giovedì, ostacolo, ostacolo, ostacolo, Capua e Caserta; venerdì, ostacolo, ostacolo, ostacolo, Capua e Caserta; sabato, ostacolo, ostacolo, ostacolo, Capua e Caserta.

**SERVIZIO DELLE DILIGENZE PER VIA DEI TORRELLI** — Lunedì, ostacolo e ritorno; martedì, strada da Capua a Napoli, mercoledì, ostacolo e ritorno; giovedì, ostacolo e ritorno; venerdì, strada da Capua a Napoli; sabato, ostacolo, ostacolo da Fondi a Napoli e da Capua a Napoli, domenica, ostacolo.

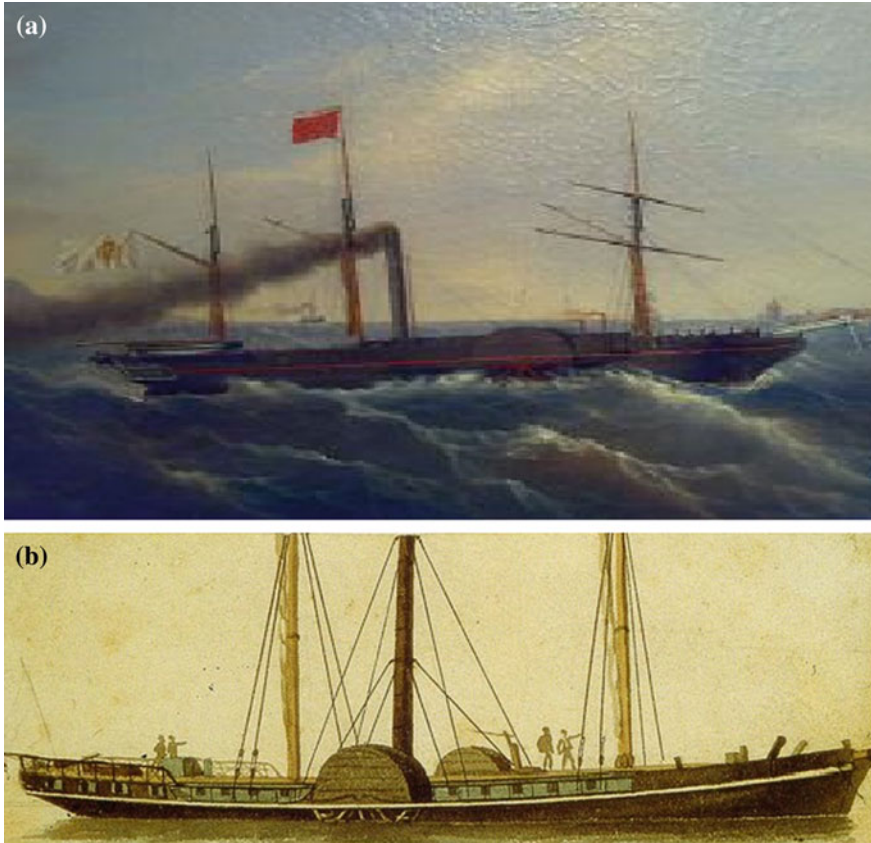
N. B. Che le prezzi sono in taluni e guisa per la strada ferrata; non vi sono partenze ed arrivi per via di mare seguiti, perché variabili.

Fig. 19 Timetable of the railway net in the Kingdom of the Two Sicilies in 1859

Figure 20 shows the “Il Giglio delle onde” (“Lily of the Waves”), the first steam ship in the Mediterranean sea and the San Ferdinando (Saint Ferdinand), the first steam ship built in Italy in 1818.

### 4.6 The Textile Industries

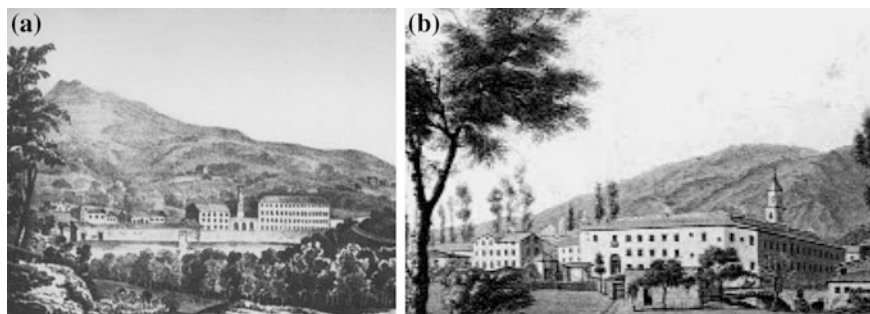
The textile industries were very advanced throughout all the industrialized world at that time, but in the Kingdom of the Two Sicilies, they reached very high levels indeed. The most emblematic example is represented by the well-known “Reali seterie di San Leucio” (Royal Silk Factories of San Leucio) near Caserta (Aversano V, Siniscalchi S). These silk factories produced silk products that were considered



**Fig. 20** The “Giglio delle onde” (a) and the San Ferdinando (b)

to be among the best in the world. The Silk Factories of San Leucio were also very famous because of the extremely advanced employment conditions of the workers, as mentioned in Sect. 2.2, concerning their social welfare. These employment conditions were later extended to all the workers in the textile factories and would later be extended to all industry throughout the Kingdom.

Another very important textile industry was cotton manufacturing. These activities were mainly developed by Swiss managers, who were largely summoned by King Ferdinando I di Borbone for the purpose of establishing cotton industries in his kingdom. Among these original Swiss directors, who operated mainly near Salerno, the most famous were Federico Alberto Wenner (1812, San Gallo, Switzerland—1882, Capezzano, Salerno, Italia), Davide von Willer (1794, San Gallo, Switzerland—1856, Napoli), and Gian Giacomo Egg (1765, Ellikon, Switzerland—1843, Piedimonte, Matese, Salerno, Italia). The factories run by von Willer and Egg are shown in Fig. 21 in pictures taken at that time.



**Fig. 21** Cotton manufacturing plants: **a** von Willer factory; **b** Egg factory

It is very worth noting that the cotton industries employed some tens of thousands of workers (not even considering satellite activities) in an area near Salerno. They suffered a slow decline after the unification of Italy, and nowadays, nothing more remains of those industrial activities.

#### **4.7 Other Industries**

Among the other industries in the Kingdom of the Two Sicilies, the following deserve a brief mention:

- The dry dock at the port of Naples, the first in Italy constructed out of stonework.
- The well-known ceramic factory at Capodimonte in Naples.
- The pasta factories, which received the First Prize International Award in 1853 at the International Exposition in Paris.
- The coral industries, which received the First Prize International Award in 1856 at the Industrial Exposition in Paris.
- The glove industries, which reached the widest production in Europe, with 8,400,000 pairs per year.

Finally, it must be remembered that Napoli had the largest number of printing workshops (113) in Italy and the largest number of published journals and magazines.

## **5 Conclusions**

This paper shows that the Kingdom of the Two Sicilies was a country that, in the first half of the 19th century, had conditions that were among the best in the world of that period. This contradicts the standard notion that Southern Italy has always been underdeveloped and that the unification of Italy was responsible for

“improvements” in that territory. The prominent achievements in many fields are representative of a society that was very active in all sectors, even if, very likely, they were not yet quite ready for the great changes brought about by the Industrial Revolution. Nevertheless, the examples discussed in the paper demonstrate that the first sparks of the Industrial Revolution could be seen in the Kingdom of the Two Sicilies, an impetus that was not, unfortunately, evident in the unified nation of Italy. This paper outlines all aspects of prominence that deserve more investigation, both for the purpose of understanding their total value and impact and for researching the motivations of their success at the time of the Kingdom, as well as the reasons for their decrease and eventual annihilation after the unification of Italy.

## References

- AA. VV. Il centenario delle ferrovie italiane 1839–1939 (Pubblicazione celebrativa delle FF.SS), Roma (1940)
- Acton H (1961) I Borboni di Napoli. Aldo Martello Editore
- Acton H (1968) Gli ultimi Borboni di Napoli. Aldo Martello Editore
- Aversano V, Siniscalchi S Il sistema sanitario meridionale nel codice di San Leucio. <http://www.iconfronti.it/Il-sistema-sanitario-meridionale-nel-codice-di-san-leucio-1/>
- De Crescenzo G (2009) Ferdinando II di Borbone. La Patria delle due Sicilie. Editoriale Il Giglio, Napoli
- De Crescenzo G (2012) Le Industrie del Regno di Napoli Grimaldi & C. Editori. ISBN-13: 978-8889879870
- De Crescenzo G, Di Giovine FS, Turco, Vitale S (2001) La difesa del Regno: Gaeta, Messina, Civitella del Tronto. Editoriale Il Giglio, Napoli
- De Rosa L (1968) Iniziativa e capitale straniero nell’industria metalmeccanica del Mezzogiorno, 1840–1904. Giannini, Napoli
- Giordano F (1864) L’Industria del ferro in Italia. Tip. Gotta e Capellino, Torino [http://books.google.it/books?id=RGRJAAAAYAAJ&printsec=frontcover&hl=it&source=gbs\\_ge\\_summary\\_r&cad=0#v=onepage&q&f=false](http://books.google.it/books?id=RGRJAAAAYAAJ&printsec=frontcover&hl=it&source=gbs_ge_summary_r&cad=0#v=onepage&q&f=false)
- Grippo A (2008) Uno Dio ed uno Re. Editoriale Il Giglio, Napoli
- Montalto M (2007) La Marina delle Due Sicilie. Editoriale Il Giglio, Napoli
- Morandi R (1972) Storia della grande industria in Italia, Einaudi. ISBN: 8806046551
- Nitti FS (1900) Nord e Sud. Roux e Viarengo, Torino-Roma
- Nitti FS (1903) Scienza delle Finanze, Piero
- Porcaro G, Cisternino R (1954) La Marina Mercantile Napoletana dal XVI al XIX secolo. Fausto Fiorentino-Editore, Napoli
- Statuto di San Leucio (o Codice leuciano) (1789)

# Medium Size Companies of Mechanical Industry in Northern Italy During the Second Half of the 19th Century

Yibing Fang and Marco Ceccarelli

**Abstract** In this chapter, the historical conditions and evolutions of the Mechanical Industry in Northern Italy are outlined as occurred after the Italian unification in the second half of the 19th Century, with Italian peculiarities in the Industrial Revolution. Observations and historical findings are discussed, referring to medium-size companies, a few examples of which are explained to stress the peculiarities of the time and locations.

## 1 Introduction

Nineteenth-century Italy tends to be considered far more from a political perspective than in regard to its technological developments, as the history of the Risorgimento that pushed the Italian peninsula into becoming a united nation was such a major event. And yet, it was from the middle of the 19th Century up to the eve of World War I that the Italian Peninsula experienced its surging industrial revolution, which could be considered to be the other key historical event to have strongly influenced the evolution of most areas of the new unified country. These two major historical events resulted in the development and industrialization of a machine technology of considerable variety and complexity.

Most previous studies have focused mainly on the general perspective of political changes and their influences on the social and economic development in 19th-century Italy (Banti 2009; Beales and Biagini 2002; Montanelli 2011). Only

---

Y. Fang (✉)

Institute for the History of Natural Sciences, Chinese Academy of Sciences,  
Beijing, People's Republic of China  
e-mail: yibing@ihns.ac.cn

M. Ceccarelli

Laboratory of Robotics and Mechatronics, University of Cassino and South Latium,  
Cassino, Italy  
e-mail: ceccarelli@unicas.it

recently have scholars concentrated on the study of technological development with engineering insights, for example, in Angotti et al. (2010; Cardone and La Mantia 2006), but few of them have emphasized the different evolution patterns of machine technology in different manufacturing fields and geographical locations, which have a close relationship to the political change and industrial revolution.

In order to reconstruct the real historical process of machine development during Italy's Industrial revolution, cases of different manufacturing fields and geographical location should be studied separately. A previous work (Fang and Ceccarelli 2014) had concentrated on two cases of famous big-size locomotive manufacturers, namely the Pietrarsa workshop in Napoli and the Ansaldo Company in Genoa, as representing two types of large-size enterprise that were developed in the earliest stages of Italy's industrial revolution in two of the primary traditional heavy engineering fields—locomotive and ship building. But there were also a lot of small- and medium-size enterprises in new machine manufacturing fields that were developed quickly in northern Italy after the unification, especially when the technological infrastructure, such like the educational system and market volume in the north, became more and more suitable for industrialization. From the point of view of technological history, the development of these small and medium enterprises in northern Italy represent the other evolution models of new emerging machine technology after the unification, since it differs from that of the traditional heavy engineering technologies and their industrialization.

Therefore, in order to give deep insight into the differences between the medium-size enterprises and the large-size engineering enterprises, and to reconstruct the historical phenomenon of new emerging machine technology's development during the political changes and industrial revolution in 19th Italy, this paper has concentrated on the development of medium machine enterprises in northern Italy during the industrial revolution of the 19th century.

## **2 A Short Account of the History of Italy**

Italy had been a territory of foreign domination and territorial fracture since the fall of the Roman Empire in the 6th century. During the Middle Ages, Italy was divided into a large number of independent political entities that eventually coalesced into five major states—Naples, Florence, Rome, Venice, and Milan—and several minor ones. The history of these five states formed the main historical scenes of the Italian Renaissance. On the other hand, the emergence of urban communes and the sharp economic change in the pre-Renaissance period transformed northern Italy from a sparsely-peopled region dominated by ecclesiastical estates and vast areas of forest into the urbane, economically-active Italy of the Renaissance. Milan, Venice, Pisa and Genoa sequentially grew into an industrial



and commercial core due to different industries, such as the woolen industry, arms manufacturing and the shipbuilding industry, rising to prominence at different times. But northern Italy fell into a period of industrial decline in the 17th century when it faced competition from the expanding Atlantic community. Meanwhile, southern Italy had followed a very different economic path. Rome regained its place amongst the great cosmopolitan cities of Europe, with numerous churches, palaces, squares and fountains, during the 15–17th centuries. Naples, as a capital city in the South, grew into the second largest city in Europe after Paris, with a population of over 200,000 in the first half of the 16th century (King 1985). Unlike the cities of the North, the growth of Naples and Rome was mainly due to the development of artisan crafts, building trades and certain luxury industries, like silk. However, by the end of the 18th century, Italy had become an economic backwater, with 80 % of the active population engaging in agriculture alone (King 1985). While her neighbors Spain and France reaped the economic benefits of physical size and the large markets of unified nation-states, Italy remained deeply fragmented, as shown in Fig. 1.

It was the Napoleonic occupation at the beginning of the 19th century that caused several changes to the whole peninsula. Innovations were introduced by the French and the boundary was reshuffled, but the most important influence was the evocation of the national pride of Italy. Although the Vienna Settlement of 1815 returned Italy to a system of separate states, it was unable to stop the progression of Italy's nationalist movement of the 19th century with what is called the *Risorgimento*. In the meantime, the Industrial Revolution that had originated in England spread very quickly around Europe, also had influences on the economic situation of Italy's various regions before unification. The northern regions of Italy benefited from the increased demand caused by the explosion of industrial textile consumption in Western Europe and North America, since most textile manufacturing was concentrated in northern Italy. The second influence was in the matter of information and mental attitudes. The Industrial Revolution aroused the interest of certain progressive intellectual circles, the members of which were beginning to travel so as to study technical knowledge and experiments in other countries. Some new periodicals, such as the *Politecnico* of Cattaneo (1839), were published with the aim of promoting technological knowledge and practical science in the Italian peninsula (Fig. 2). The concentration on production of textile materials in the north and the interest in new technological knowledge and practical science coming from Europe's Industrial Revolution caused the emergence of the earliest industrial societies in Italy, and caused the peninsula to be on the eve of its own industrial revolution before the unification (Cafagna 1972).

In this paper, we have focused attention on recovering the peculiarities and understanding the development of industrial enterprises in northern Italy in the emerging framework of Italian industry.



Fig. 1 Italian political situation in 1840 before reunification

### 3 Mechanical Industry and Middle Size Companies in the 19th Century

During the period from the middle of the 19th Century up to the eve of World War I, the development of mechanical industry and engineering was one of the most notable phenomena of Italian industrialization. As mentioned above, the development of machine technology in 19th-century Italy was influenced by the political changes and the Industrial Revolution occurring in the other advanced countries of Europe, which had their own very different conditions and peculiarities. Three types

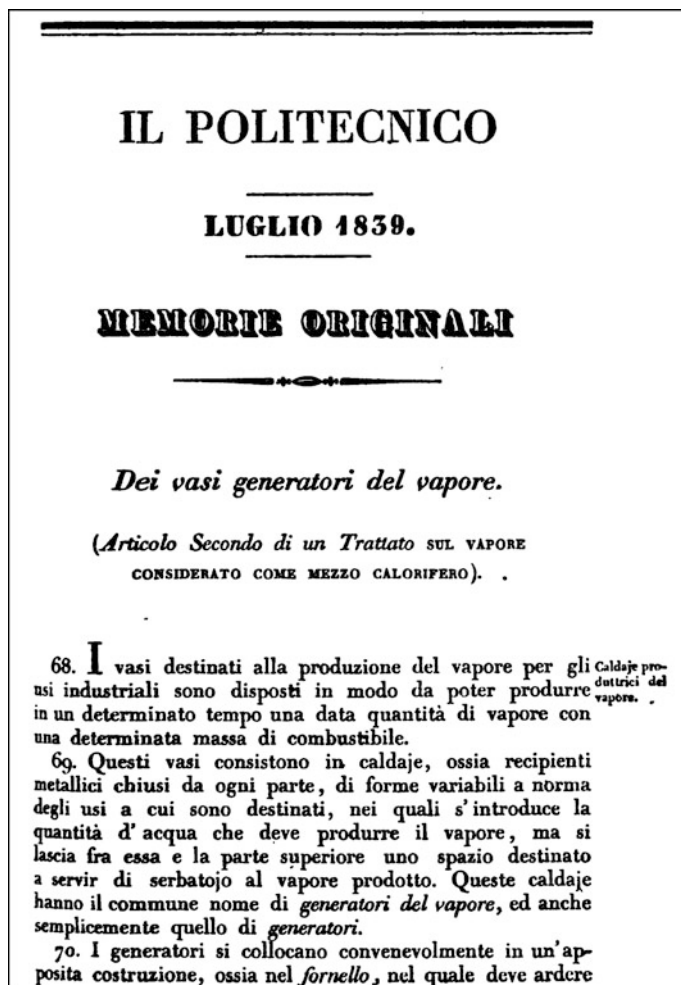
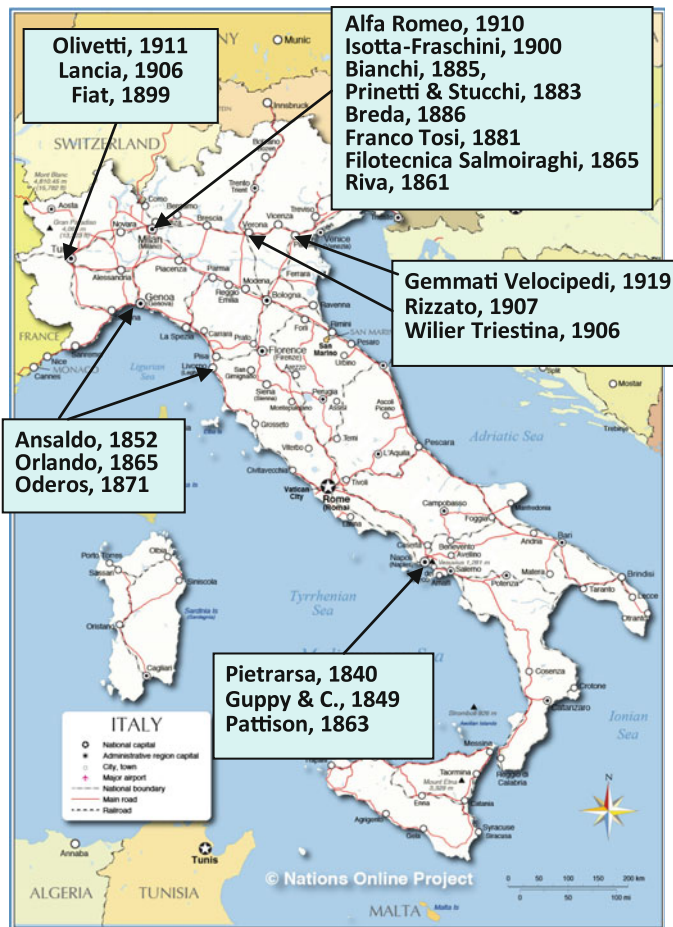


Fig. 2 An article about vessel steam generators in vol. II of Il Politecnico

of entrepreneur in machine development of this time could be considered the main actors in the foundation and development of modern machine technology and industry in the period of unification.

Unlike some other industrial fields, such as the textile industry that initially flourished in the northern part of the Italian peninsula, the process of industrialization of modern machine engineering was launched in the Kingdom of the Two Sicilies in southern Italy at the end of the 1830s (Fang and Ceccarelli 2014). The first locomotive manufacturer in Italy, the Pietrarsa workshops, and other heavy engineering factories were established directly on the order of King Ferdinando II, making the city of Napoli the largest industrial hub of mechanical engineering on

the peninsula before the unification (Rossi and Ceccarelli 2013). However, when the unification occurred in the 1860s, it not only changed the political situation but also changed the situation of the mechanical engineering industry, as summarized in the industrial sites distribution shown in Fig. 3. The industrial centre moved from the south to the north. Most of the southern machine companies began to decline, while the enterprises in the north grew rapidly; some, like the Ansaldo Company of Genoa, became famous engineering giants during the second half of the 20th century, owing to the idea of economic nationalism and the direct support of national policy. Apart from the well-known large-scale companies which were the main objects of most previous studies, most of Italy's mechanical companies during this period were of medium and small size, as, indeed, is still the case today.



**Fig. 3** A map of the main machine companies established during the industrial revolution of Italy

According to today's EU definition, medium-size enterprises are companies whose number of employees is between 50 and 250. The medium-size mechanical enterprises are summarized in Table 1 for the largest share of the total number of existing mechanical enterprises in 1864, according to a statistics. Some of these enterprises have developed successfully and played a significant role in certain manufacturing fields, such as the production of turbines and precise instruments. Actually, most of the manufacturing fields of medium-scale machine enterprises were the new fields developed within the framework of the European Industrial Revolution's 'second stage', the basic technological features of which were the large-scale use of new materials and the introduction of new sources of energy (Cafagna 1972). The birth of a hydroelectric industry from the late 19th century up to 1914 was undoubtedly the most key aspect of Italy's Industrial Revolution, which was definitely orientated towards the 'second stage', providing larger business opportunities to the new generation of entrepreneurs in the north who mastered the knowledge of new technologies and led to the development of manufacturing of hydroelectric station equipment such as turbines. Besides machine production related to the hydroelectric industry, some other medium-size high-tech machine enterprises also arose in Italy as the result of a new or larger market demand being formed by the political unification. The manufacturing of precise instruments was a typical example. In general, such a manufacturer needed to master advanced technology, so they had to have more close contact with the local technical educational system and were usually in a complex and competitive market environment, if we consider the strong competition that came from the other advanced industrial European countries.

**Table 1** A summary of existing mechanical factories in Italy, 1864, (Giordano 1864)

Province	Ancona	Bergamo	Bologna	Brescia	Gagliari	Como	Cuneo	Firenze
LE	1	0	0	1	0	0	1	1
ME	1	0	2	0	0	3	0	3
SE	0	1	0	1	1	0	0	0
Total	2	1	2	2	1	3	1	4
Province	Genova	Livorno	Lucca	Milano	Modena	Napoli	Novara	Palermo
LE	4	0	0	2	0	3	0	1
ME	3	0	1	3	0	2	3	0
SE	1 <sup>a</sup>	3 <sup>a</sup>	0	1 <sup>a</sup>	1	2 <sup>a</sup>	5	1 <sup>a</sup>
Total	8	3	1	6	1	7	8	2
Province	Placenza	Pisa e Prato	Siena	Perugia	Torino	Others	Total	
LE	0	0	0	0	2	5	21	
ME	0	0	1	2	4	3	31	
SE	1	2 <sup>a</sup>	0	0	0	4 <sup>a</sup>	24	
Total	1	2	1	2	6	12	76	

LE means an enterprise with more than 250 employees; ME is for enterprises with 50–250 employees, SE is for enterprises with less than 50 employees

<sup>a</sup>The figures are estimates, because of the lack of employee data

In this paper, the history of medium-sized mechanical companies in northern Italy during the period of the Industrial Revolution is discussed, giving their primary characteristics and the role they played in the development of machine technology and mechanical industrialization. Beside general considerations, the discussion is focused on cases of study for three medium-size mechanical companies from specific manufacturing fields.

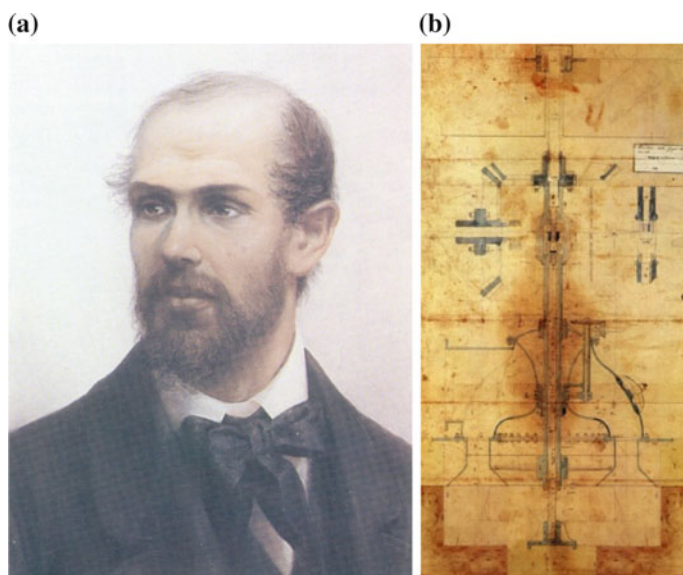
## 4 Medium-Size Companies in Northern Italy

Starting in the middle of the 19th Century, a lot of small- and medium-size mechanical enterprises were begun as the result of active entrepreneurial behavior in northern Italy. The results enjoyed by these companies were different because of the difficult and complicated situation of the emerging mechanical market in Italy. Bankruptcy and mergers happened very frequently. Nevertheless, such active entrepreneurial behavior, no matter what the result, caused Italian mechanical technology to be well-developed independent of the advanced countries in certain special production sectors. The following three cases can be considered typical examples of entrepreneurial activities in turbine and precise instrument manufacture which had different results during the second half of the 19th Century.

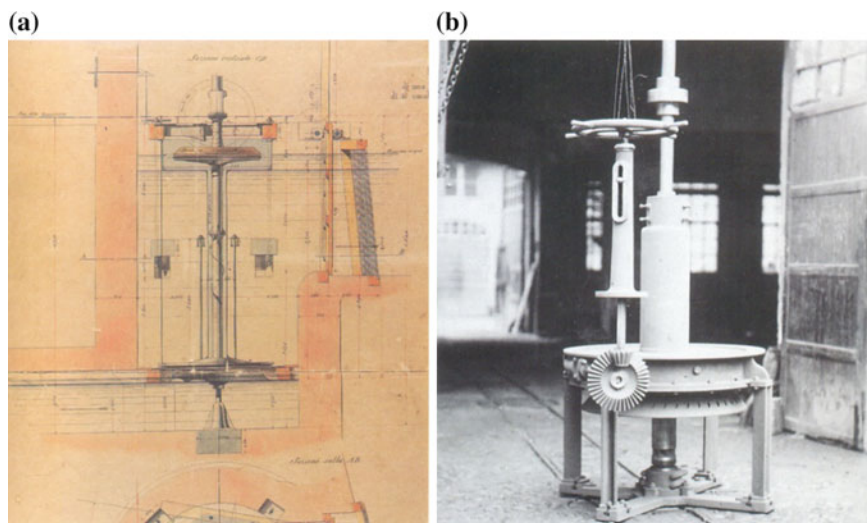
### 4.1 *Alessandro Calzoni S.P.A in Bologna*

Calzoni Enterprises was founded in 1830 by Alessandro Calzoni (1807–1855) (Fig. 4a) as a small foundry that used a press to produce cutlery in pewter. The factory was located in the very centre of Bologna. After Calzoni moved into the church of del Carrobbio in the Piazza della Mercanzia, business improved so much that he was able to expand the factory to produce agriculture machines as well. In 1863, the factory moved to a new site in via Pietramelara in the area between Canale delle Moline and the nearby railway station. From then on, the company concentrated on the industrial production of hydraulic engines, machinery, drives for mills, and oil presses, as well as machines and whole plants for other factories. In 1867, the first hydraulic turbine was produced in Calzoni, as shown in Fig. 4b. There were 100 employees at Calzoni in 1872. In 1887, hydroelectric plant activities were increased and consolidated. Among the engineering firms in Bologna, the Calzoni workshop specialized in the manufacture of hydraulic turbines from then on (Curti and Grandi 1998).

The Calzoni Company of Bologna was the first company in Italy to adopt American types of turbine, and in the present day, it still has about 1900 systems installed. The company was moved to a larger area on the outskirts of Bologna in 1920, with activities being focused on water turbines and iron castings, as shown in the example in Fig. 5. The engineer Alfredo Calzoni was appointed Managing



**Fig. 4** **a** Portrait of Alessandro Calzoni from the 1850s. **b** Drawing of the hydraulic turbine produced in 1867 (Curti and Grandi 1998)



**Fig. 5** A hydraulic turbine produced by Calzoni in early 20th Century, (Curti and Grandi 1998): **a** a design drawing; **b** a product ready for sale

Director due to his reputation for technical skill (Curti and Grandi 1998). In 1923, the Calzoni family acquired shares of the “Costruzioni Meccaniche Riva” company of Milan and established a cooperative agreement with the RIVA Company, which led the Calzoni Company to entrust the manufacture of turbines and regulators to the Milan-based company “S.A. Costruzioni Meccaniche Riva Ditte riunite A. Riva—A. Calzoni”. Meanwhile, the factory in Bologna was reorganized and developed to build hydraulic systems for different applications, like servomotors, hydroelectric gate drives, and hydraulic motors.

In 1931, Calzoni produced its first hydraulic systems in the naval arena, with the supply of hydraulic rudder controls for the Italian submarine “Victor Pisani”. In 1966, the Calzoni workshop in Bologna and the Riva workshop in Milan merged together to form the new Company RIVA CALZONI SpA, which still engages in significant industrial activity to this day.

## 4.2 *Riva Company in Milan*

The first activities of the Riva Company, as a plant founded by Antonio Paolotti and some others for the “manufacture and sale of machinery and steam centrifugazione and any other”, date back to September 29, 1861, with a location at No. 3711 Road Course Vettabbia in Milan. In 1876, Hercules Porro, a brilliant engineer who graduated from the Politecnico di Milano, joined Paolotti’s company with a considerable financial support of 25,800 Lire (Bigatti 1988). The arrival of Porro marked a turning point in the technical management of the workshop. The workshop’s production was limited to the locomobile’s Stigler system and the boiler for power applications. It is notable that the two partners in the company had completely different backgrounds. Paolotti was an illiterate, who spent a long time as a military artisan, and Porro was an engineer trained in mechanical engineering at the Milan Polytechnic, and a member of the new manager class capable of technical transfer.

Thanks to the skills of the young engineer Porro and the favorable economic situation, the plant ran well. In 1874, a limited partnership, Paolotti, Porro & C, was formally established with a capital of 105,000 Lire. In 1875, Porro took over Paolotti’s share and changed the company’s name to E. Porro & C. Unfortunately, Porro died suddenly in August 1876 and his widow decided to entrust the management of the company to the engineer Giovanni Morosini. Morosini was a professor of agricultural mechanics at the School of Agriculture, Milan, who used his expertise to develop agricultural equipment in that city. The company’s name changed to Porro & C. di Colombo & Galimberti soon after. In 1879, Ernesto Galimberti, the brother of one of the company’s owners, joined the company and became the technical director, while Morosini took charge of the management work (Bigatti 1988).

Porro & C. di Colombo & Galimberti was a typical small- and medium-size mechanical company in Milan at the end of the 19th century, existing without



governmental support and requiring self-finance to survive. In the 1880s, the Colombo and Calimberti group held one third of the capital shares of the company, while most of the other members were from the world of professionals (engineers) and traders, who were bound by ties of kinship, friendship or acquaintance with the manager. But the fortune of the company gradually became worse; even the start of production of hydraulic turbines in 1887 could not turn the situation around. At the end of 1888, the capital shares of the company were reduced to 246,000 Lire, which led Ernesto Galimberti to put the company into liquidation and to negotiate for an agreement with the A. Riva & C. Company for a merger of the two companies and the reduction of the nominal capital share of Galimberti to 50 %.

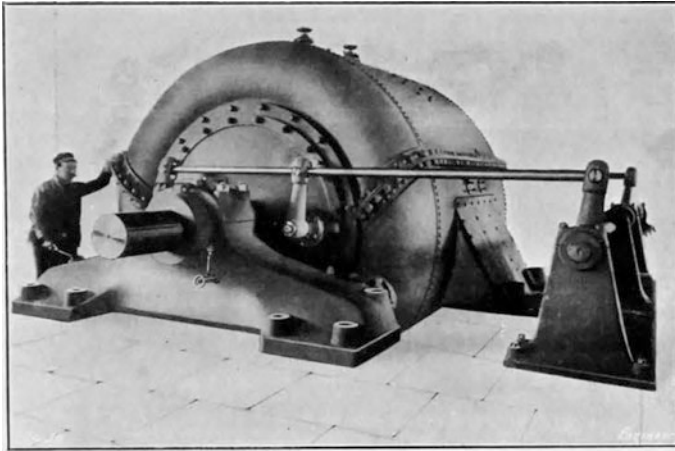
The A. Riva & C. Company was founded in 1872 by Alberto Riva, a young man who graduated from Politecnico di Milano and gained his first work experience in Switzerland, in the industrial firm of Caspar Honegger. In 1887, Ugo Monneret joined Riva's firm as a technical director. In 1894, the company's name changed to A. Riva, Monneret & C. In 1889, the company began the construction of hydraulic turbines, for which specialty it gradually abandoned other work.

In a report on the Italian industry written by the representative of the British Journal "The Engineer" in 1906, Riva Monneret and Co. was considered to be "one of those who have specially contributed to render the hydroelectric science in Italy an absolutely national one in its application, and to eliminate the necessity of foreign aids for machinery and its accessories"(Editorials 1906, p. 468).

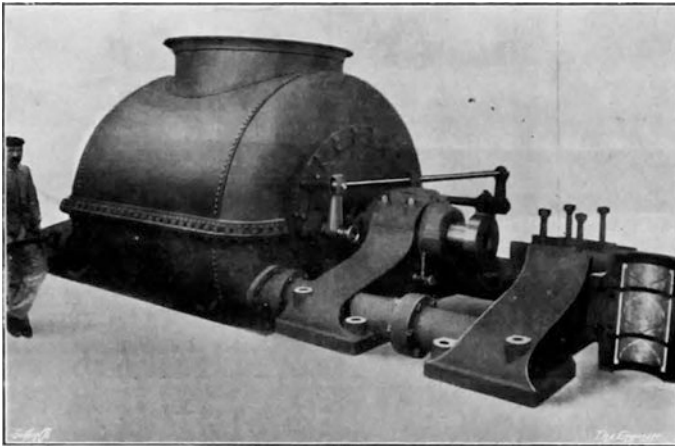
In 1893, they equipped the central power station at Pordenone with turbines of 450 HP, built for driving dynamo machines, and began to adopt the Francis reaction turbine type with horizontal spindle for direct-coupling. Two years later, they constructed five turbines for the central hydro-electric station in Castellamonte, the first large station in Italy for the distribution of electrical energy, three of 750 HP and two of 100 HP. The work was so successful that they received more commitments for other plants.

In a short time, the company provided equipment for the power plants in such important stations as Bussoleno, Paderno, Vizzola, Lanzo Torinese, Pont, St. Martin and Ala Ceres, by using Francis turbines controlled by automatic water pressure governors, as shown in Figs. 6 and 7. Rapidly, the name of the firm became appreciated for its honesty and good work, to the point that, in 1899, it was contracted by the Hanniton Cataract Power Company of Canada to construct two 3000 HP Francis turbines for high fall (78 m), with horizontal spindles to work at 286 revolutions per minute, for its station in Niagara. These great engines were sent to Canada unaccompanied by mechanics belonging to the constructing house, and, in spite of this handicap, ran from the first without a hitch.

In addition to the construction of Francis turbines for large or small volumes of water, and to falls from 2 m to over 100 m, the firm was renowned for its Pelton turbines, which were specially modified for the application of water-pressure governors, and for its automatic oil regulators, for which they had their own patent. This original governor was exported all over the world during the beginning of the 20th century. It was said that this appliance had solved a problem which had puzzled hydraulic engineers for many years (Editorials 1906, p. 469).



**Fig. 6** 2500 HP Turbine with an old elastic joint by Riva Monneret and Co at Paderno station at the end of the 19th century. *Source Editorials (1906)*



**Fig. 7** Hydraulic turbines by Riva Monneret and Co at the Vizzola station at the end of the 19th century. *Source Editorials (1906)*

According to a report in “The Engineer” in 1906, the Riva Monneret Company “has been able to solve, by its patented oil regulator, the problem of the governing of the turbine wheel, and has constructed more than 1200 turbines of an aggregate power of nearly 300,000 HP”.

In 1911, under the suggestion of engineer Guido Ucelli, Riva started to develop pumps in addition to turbines, in order to complete the production of large hydraulic machines for hydroelectric stations.

In 1923, the Calzoni family established a cooperative agreement with the Riva Company which led to establishment of the biggest turbine maker in Italy, namely “S.A. Costruzioni Meccaniche Riva Ditte riunite A. Riva—A. Calzoni”.

New solutions were developed which gave rise to patents over the years, such as the switch of the jet in 1908, the rectilinear introducer in 1947 and the hydraulic reflector in 1960 (Ucelli 1961).

The development of the Riva Company in its early stage can be considered to be a typical example of the active entrepreneurial behavior in new machine manufacturing areas in northern Italy during the second half of the 19th century. This type of company was usually founded by a local technician who had access to knowledge of a new manufacturing field. After its foundation, several engineers or professors of engineering in the company’s city would join as managers, due to the frequent change in the company’s financial and operating situation. Most of these managers were from the local engineering educational institutes, such as the Politecnico di Milano. In the early stage of development, the company’s name changed very frequently, accompanied by the frequent occurrence of bankruptcies and mergers, as shown in Fig. 10. Such network history was quite common in many small- and medium-size Italian companies at their genesis. It was such unstable entrepreneur’s process that caused new machine manufacture technology to be so well-localized and well-developed in the north (Fig 8).

The Riva Company is also a representative example of the remarkable growth of the new Italian industrial frames, such as the machinery of the hydraulic electrical industry in northern Italy from the middle of the 19th Century up to World War I. After 1915, Italian turbine manufacturers could meet all the needs of the domestic market, and most of the producers were located in northeast Italy, as shown in Table 2. From Table 2, it is also remarkable to note that all those companies started and evolved successfully in the same years with almost no competition among them because of a very dynamic market for industrializing the country. In a few years, some of those small- and medium-size companies evolved considerably as a result of their own original production, allowing them to grow into significant large companies.

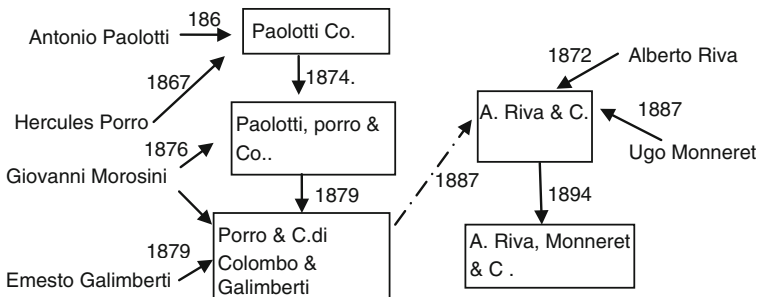


Fig. 8 A schematic of the network of the Riva Company’s development in the 19th century

**Table 2** Italian manufacturers of Hydraulic Turbines (1923), Production for both Italy and abroad

Firms	Location	Start of production	Number of turbines	Total power produced till 31-12-1923 (HP)
S.A. Costr. Meccaniche Riva Ditte Riunite A. Riva-A. Calzoni	Milano	1885	2669	2,258,729
S.A. Franco Tosi S.A. San Giorgio	Legnano Sestri P.	1913	204	567,000
S.A. Officine Calzoni-Parenti	Bologna	1885	2218	288,575
Ing. S. De Pretto & C.S.A. De Pretto-Escher Wyss	Schio	1893	936	157,038
S.A. Cantieri Navali-Acciaierie	Venezia	1908	300	22,000
S.A. Ing. Moncalvi & C.	Pavia	1905	719	19,427
S.A. Officine Riunite Italiane	Brescia	1892	349	14,705
S.A. Off. Meccaniche e Fonderie Ing. Pietro Veraci	Firenze	1905	164	9800
Total			7589	3,337,274

Source Ucelli (1924)

### 4.3 *Filotecnica Salmoiraghi in Milan*

The Filotecnica was founded in 1865 by Ignazio Porro (1801–1875) (Fig. 9a), a professor of Optics at Milan University and a pioneer inventor in the field of wide-angle lenses. Porro was born in Pinerolo, Italy, on November 25, 1801, the son of an engineer-lieutenant. He received his education in Turin, attended military college, and joined the Artillerie as a cadet. He served in the Piedmontese Corps of Engineers until 1842. In fact, Filotecnica was the business of Porro's later years. As a pioneer Italian inventor of a prism image erecting system and a number of other scientific instruments, Ignazio Porro opened a workshop in Turin in 1842 to produce scientific devices of his own technical innovation. He moved to Paris five years later, where he opened the Institut Technomatique and developed an improved asymmetrical camera lens that enhanced image quality. It was also during this time that Porro invented his direct-vision prism image erecting system, which he patented in both Paris and England in 1854. Ignazio Porro returned to Italy in the 1860s to teach tachymetry and surveying theory in Florence and Milan. Filotecnica was founded during this period (Boley 1975).

In fact, Filotecnica was more like a kind of laboratory than a real company, existing for the construction of optical instruments and measurement at an experimental level, especially for topographic and geodetic use. In 1866, when Angelo Salmoiraghi (Fig. 9b) graduated from the Politecnico of Milan under the guidance of Ignazio Porro, he entered the Filotecnica and took a position of responsibility soon after. Salmoiraghi eventually took over the company and its name was changed to Filotecnica Ing. A. Salmoiraghi.



**Fig. 9** Founders of Filotecnica Ing. A. Salmoiraghi: **a** Ignazio Porro (1801–1875); **b** Angelo Salmoiraghi (1848–1939)

Under Salmoiraghi's leadership, the company grew significantly, acquiring a leading role among the manufacturers of optical instruments and precision. In addition, it was the first company to produce sewing machines in Italy, starting in 1877.

Angelo Salmoiraghi also played an important role in civil society and in the industrial community. He was the president of the Chamber of Commerce of Milan. In 1901, he became the first president of the newly formed Unioncamere. He was also a Senator during the early years of the 20th Century.

The period in Italy from the unification up to World War I was a time during which modern industries were established with a dimension and efficiency that were almost comparable with those correspondents in other parts of Europe. When considering the field of science instrument manufacture in Italy, Italian companies had to compete with strong rivals from France, Germany and England, such as Mertz of Germany, Feil, Bruner Brothers, Martin and Henry Brothers of France, and Simms, Cookes, and Dalmeyer of England, which had already developed significantly by the middle of the 19th century. Even though the unification of Italy created a big Italian market for geodetic instruments, because of the need to draw the political map of Italy all over again, it was hardly possible to establish a company in a short time to meet the new requests without being overrun by foreign industries which were already operating heavily in Italy (Sutera 1990). Filotecnica Salmoiraghi was one example of the new precise instrument maker that was established and survived after the unification of Italy.

From the beginning of the 20th Century, Filotecnica Salmoiraghi had to make considerable effort to bring its production into the market. They diversified

production, and the company's catalog expanded from photographic units to instruments for navigation and astronomy. During World War I, they provided military equipment, especially cameras in aircrafts for aerial shots. After World War I, Salmoiraghi (who was also a senator at that time) argued with the Italian government in a fight against a suggestion in the war reparations which stated that Germany could pay off its debts in part by supplying scientific instruments. Since World War I, the company had begun to produce cameras designed for civil use. In this time, its products were also provided to foreign companies, such as the British Houghton Butcher Manufacturing Co.

During World War II, most of its production was devoted to war instruments. In the early 1950s, the Company joined a group of state-enterprises (IRI), subsequently becoming part of the Aeritalia and merging into Salmoiraghi & Viganò, which is a current leader in the eyewear sector (Selvini 1986).

From the point of view of history, Filotecnica Salmoiraghi can be considered to be the other successful case of a medium-size machine company which was founded by Milanese entrepreneurs and had a close relationship with the universities in Milan. The business was initiated directly by the inventions and the enthusiasm for innovation of a professor at Milan University, and was then successfully developed under the management of one of the professor's students. From Fig. 10, it is notable that the close relationships between the universities and the small- and medium-size companies were so common in Milan during the second half of the 19th century that Milan became the birthplace of several companies



**Fig. 10** A group of graduates of Politecnico di Milano, including several founders and leaders of northern Italian industry. From *left to right*, standing: Alberto Riva, Bartholomew Cabella, Colombini, Carlo Salviotti, Giovan Battista Pirelli, Rasura, Saldini Cesare, Angelo Salmoiraghi; sitting: Pius Borghi, Tommasini

engaged in new manufacturing technology, with the city playing an important role in the industrial development of Italy ever since.

## 5 Conclusions

The character of the medium-size companies of mechanical industry in northern Italy during the Industrial Revolution can be summarized as follows:

- (a) They were founded around the unification of the country. After the unification, most of the companies experienced rapid development owing to the new demands created by unification and the large national market.
- (b) They were founded and developed without governmental support, requiring self-finance, a significant difference from large-scale companies like Ansaldo.
- (c) These companies had strong relationships with the main engineering educational institutes of their respective cities, such as the Politecnico in Milano. The founders or main managers of these companies were either professors or students who graduated from those universities. Their educational experience and new technical knowledge led them to become an active group of new entrepreneurs after the unification of Italy.
- (d) Since these medium-size companies did not have financial and policy support from the government, they had to face a market which was more competitive and difficult than that for big companies. In order to adapt to such a situation, these companies showed more innovative and flexible ability than the big companies, as represented by the high number of patents submitted by them. Because of this, those companies experienced a historical evolution, with a number of changes and adaptations occurring both in financial structure and product variety.
- (e) They developed enhancements or new solutions for specific machinery and application in Italian frames, occurring mainly in northern Italy.

**Acknowledgments** The primary author gratefully acknowledges the support of the Chinese Academy of Sciences for a period of study in Cassino A.Y. 2012–2013.

## References

- Angotti F, Pelosi G, Soldani S (eds) (2010) *At the roots of modern engineering: expertise and opportunities in Florence at 19th century*. Firenze University Press, Firenze (In Italian)
- Banti AM (2009) *Italian Risorgimento*. Editori Laterza, Rome (In Italian)
- Beales D, Biagini F (2002) *The Risorgimento and the unification of Italy*. Longman, London
- Bigatti G (1988) *Merchants and entrepreneurs in Milan post-unification: the origins of Riva, 1861–1896*. *Storia e società* 11:53–99 (In Italian)

- Boley B, Porro I (1975). In: Gillispie C (ed) *Dictionary of scientific biography*, vol XI. Scribner, New York, p 95
- Cafagna L (1972) The industrial revolution in Italy 1830–1914. In: Cipolla CM (ed) *The fontana economic history of Europe: the emergence of industrial societies*, Part 1, vol IV. Gollins/Fontana, Glasgow, pp 279–328
- Cardone V, La Mantia FP (eds) (2006) *The History of Engineering and Engineering Study in Palermo and in Italy*. CUES, Salerno (In Italian)
- Cattaneo C (ed) (1839) *Il Politecnico*, vol 1. Milan
- Curti R, Grandi M (eds) (1998) *Getting to know machinery: industry and technical education in Bologna*. Bologna, Editrice Compositori
- Editorials (1906) Italian industries. *The Engineer*. 11 May 1906, pp 468–469
- Fang Y, Ceccarelli M (2014) Findings on Italian historical developments of machine technology in 19th century towards industrial revolution. In: Visa I (ed) *The 11th IFToMM international symposium on science of mechanisms and machines: mechanisms and machine science*, vol 18. Springer, Berlin, pp 493–501
- Giordano F (1864) *Industria del Ferro in Italia*. Tipografia Cotta e Capellino, Torino, pp 355–373
- King R (1985) *The industrial geography of Italy*. Croom Helm Ltd, Kent
- Montanelli I (2011) *Italy in Risorgimento: 1831–1861*. BUR Rizzorli, Milan (in Italian)
- Rossi C, Ceccarelli M (2013) Heavy industries in Southern Italy before the unification. In: *Proceedings of IFToMM Workshop on History of MMS*, Palermo
- Selvini A (1986) The Filotecnica Salmoiraghi: one hundred and twenty years of hisotry. *Bollettino Societa Italiana di Topografia e Fotogrammetria*, 2 (in Italian)
- Sutera S (1990) The nineteen century: instruments to observe: the Contribution of Italian Makers. *Memorie della Societa Astronomica Italiana* 61(4):899–904
- Ucelli G (1924, Nov 5) The technique of Italian modern hydraulic turbines. *L'Elettrotecnica* XI (31):775–782 (in Italian)
- Ucelli G (1961) *The Riva Company in 100 years of activity*. Alfieri & Lacroix, Milano (in Italian)



**Part III**  
**History of Machinery and Transport**

# The Museum of Engines and Mechanisms. More Than a Century of History of Technology

Riccardo Monastero and Giuseppe Genchi

**Abstract** The Museum of Engines and Mechanisms of the University of Palermo has preserved more than 300 pieces, which collectively narrate the evolution of science and technology in the field of fluid machines and their components and testify to the development in scientific disciplines, technologies and industrial applications over the course of more than a century. A rigorous chronological path through the various typological groups allows for a historical walk through the last 150 years, in the area of automotive, airplanes and marine engines; hydraulic machines and stationary engines; mechanical measurements and laboratory devices for scientific and educational purposes. The collection is available for both the students and the general public, indeed, for anyone who is interested in reading about this history in a different way.

## 1 The Museum

The Museum of Engines and Mechanisms [www.museomotori.unipa.it](http://www.museomotori.unipa.it) features a collection of more than 300 items which describe the progressive development of fluid machines and their constituent parts, as well as their industrial application through a period of over a century. This museum is part of the Museum System [musei.unipa.it](http://musei.unipa.it) of the University of Palermo (MUSEIUNIPA) and is housed in the Polytechnic School of the University within the Department of Chemical, Management, Information and Mechanical Engineering.

The Museum exhibit is composed of seven main thematic areas dedicated to a particular field of technology (Figs. 1, 2 and 3). The visit itinerary provides a strictly chronological path through the last 150 years of the history of the industrial

---

R. Monastero · G. Genchi (✉)

Museum of Engines and Mechanisms, University of Palermo, Palermo, Italy  
e-mail: [giuseppe.genchi@unipa.it](mailto:giuseppe.genchi@unipa.it)

R. Monastero

e-mail: [riccardo.monastero@unipa.it](mailto:riccardo.monastero@unipa.it)

**Fig. 1** The Museum, one of the exhibition halls



**Fig. 2** The Museum, the automotive hall



**Fig. 3** The Museum, the collection of scientific and didactical devices



development in the field of hydraulic machines and stationary engines, as well as automotive and aircraft engines. The Museum is also endowed with a mechanical workshop for restoration and maintenance. Many engines come from storehouses where they had accumulated over time, set aside as obsolete and forgotten; other pieces are the result of donations and loans from other institutions; a meticulous and painstaking restoration, accompanied by careful historical researches, released each element from under the patina of many years of neglect, restoring its rightful museum dignity and making it available for students, researchers and enthusiasts, and for all people interested in reading a page of history in a different way. The museum is also the promoter of many cultural events in collaboration with various organizations for the advancement and dissemination of technology and science.

## 2 The Collections

The history of the collections began in the second half of the 19th century when the Royal School of Application for Engineers and Architects was established in 1866 (Filippi 1983). The scientific and didactical devices represent the development of studies and investigation methods in the field of machines and mechanics but also indicate the sort of transformations that portions of the academic institutions of the University of Palermo, from its foundation up until today, have gone through. The awareness of the considerable historical value of these assets, as well as their collective value, and the need to preserve them necessitated their restoration and suggested organization in a museum setting; a meticulous historical research and the acquisition of technical data was undertaken towards this aim. The analysis and synthesis of the large amount of collected data (Genchi and Sorge 2012) also allowed for the creation of an extensive iconography: each item is endowed with an explicative panel that contains historical and technical information along with photographs and drawings. The simple and linear set-up of the museum groups all the items in each section following a rigorous chronological order that highlights the development of different systems, technical arrangements, materials for various purposes and applications. Considering the educational purposes of the museum, a key role is played by the section of scientific instruments and didactic devices, which provides a broad overview of the possible solutions in the realization of complex mechanisms.

## 3 Stationary Engines

The steam engines were the first modern machines used to obtain mechanical power for industrial and transportation applications. They played a key role from the end of the 18th century, as part of the First Industrial Revolution, until the second half of the 19th century, during the Second Industrial Revolution. The use of the steam engine in the manufacturing processes of raw materials and consumer products and in the production of electricity and transport, as is well known, entailed considerable and irreversible effects that determined the passage from a socio-economic system mainly based on agricultural and commercial activities into the modern industrial system. After ranking in the second half of the 19th century, the use of a large steam engine to drive machinery in a manufacturing plant, such as the frames of a textile factory, or the machine tools and mechanical pumps used for water extraction in mines, remained nearly unchanged until the first half of the 20th century, according to a typical industrial scheme.

At the Royal School of Application for Engineers and Architects in Palermo, the first studies related to the steam engines date back to that period, as demonstrated by the oldest scientific equipment in the Museum and the presence of the large steam engine built in Venice by E.G. Neville & Co (Fig. 4). This is a single-cylinder double-acting engine, with a displacement of 26,148 cc, providing a power output of

**Fig. 4** Stationary steam engine “Neville” of the late ‘800



about 8 HP at 120 rpm, with a feeding pressure of 8 bar; the engine has a Meyer-type variable valve timing system controlled by a Buss-type automatic speed regulator (Schaeffer and Budenberg); the speed levelling is ensured by a large flywheel with a diameter of 2000 mm.

The Museum also has a marine compound steam engine (double expansion type), with two in-line “double effect” cylinders (Fig. 5). This is of English construction and datable from the end of the 19th century or the earlier part of the 20th. By means of the two cylinders, the low pressure one with 321 mm bore and the high pressure

**Fig. 5** Marine compound steam engine



with 181 mm bore, with an overall displacement of 34,130 cm<sup>3</sup>, this engine gave a power output of about 50 HP at 350 rpm with a pressure of 10 bar; it has a valve system with two sliding valves (high and low pressure) driven by a Stephenson reverser system. The overall structure suggests its employment in medium-sized vessels such as yachts and fishing boats. Both this machine and the “Neville”, entirely restored, are endowed with electric motors which allow the complex movement of their parts to be seen.

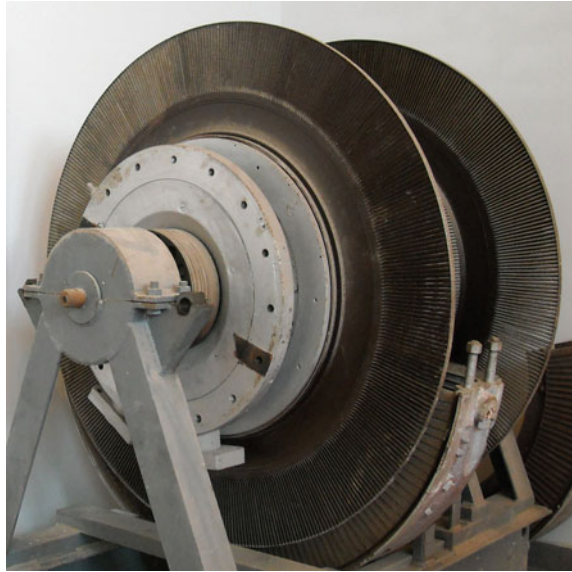
The service unit indispensable to a steam system is that intended to ensure the correct amount of water is pumped to the boiler. This task was usually entrusted to a piston pump and was commonly called the steam pump or “donkey pump”. This is essentially a motor-pump unit consisting of a double-acting steam engine which is permanently connected via a rod with the piston of a reciprocating double-acting pump, equipped with automatic valves. The steam pump at the Museum was manufactured by Peroni & C. S.p.A. of Milan in the first half of the 20th century (Fig. 6).

One piece closely related to the local history of the city of Palermo is the largest steam turbine “Ljungström” (Fig. 7) from the old power station of Via A. Volta (Porta Carbone) which, in the years from its entry into service until 1952, had the task of providing electricity to a large part of the town. This turbine, built in Sweden in 1928 by S.T.A.L. (Svenska Turbinfabriks Aktienbolaget Ljungström) in Stockholm and Finspång, features a centrifugal radial bi-rotary steam system, with the last stage of expansion of the axial type, giving 9100 kW at 3000 rpm with steam super-heated at 350 °C and a maximum pressure of 14 bar; it drove two three-phase alternators coupled in parallel, both of STAL construction, featuring 10,700 kVA, 11,000 V, frequency 50 Hz. It consists of two facing discs of suitable configuration connected to two independent counter-rotating shafts. Crowns of blades are connected to the disks, and the steam, introduced into the central compartment via the hollow shafts, flows through the blading arranged on the two discs in ordered succession heading towards the periphery. The two disks rotate with the same angular speed, but in opposite directions, and each ring of vanes acts as a distributor for the further crown (the outer one): the Ljungström arrangement is that of a reaction turbine.

**Fig. 6** Steam pump Peroni & C., “donkey pump”



**Fig. 7** Steam turbine  
“Ljungström”



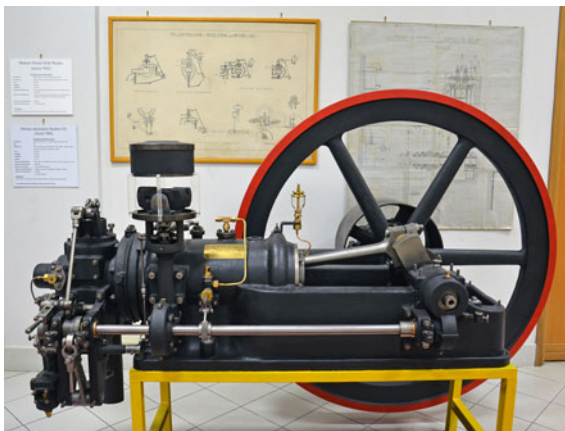
The typical drawback of a centrifugal turbine is that the work of the centrifugal forces on the fluid is negative, and this implies a lowering of the power supplied; however, this shortfall, which is a function of the difference between the maximum and minimum radii of the disks, is not excessive and is greatly compensated by the ease of the flow discharge. The progressive increase in the diameter contributes, together with the increase in the axial length of the vanes, to increasing the section needed for the passage of the expanding steam, in its path towards the outside of the turbine. In the Ljungström turbine, each blade crown can develop a work that is ideally twice that developed in one stage of an ordinary reaction turbine for the same steam rate, at the same speed and for equal mean radius; consequently, for given power, the mass and size of a Ljungström turbine are significantly lower when compared with conventional turbines.

At the end of the 19th century, piston steam engines had gradually been replaced by internal combustion engines. The fact of this development is represented by some of the stationary gas engines at the Museum. Two gas engines, a Ruston Proctor & Co. (CD series) and a Langen and Wolf (Fig. 8), and two diesel engines, respectively manufactured by Hille Werke AG (Fig. 9) and the Hanseatische Motoren-Gesellschaft (HMG) in the early part of the 20th century.

The Ruston, Proctor and Co. engine (Lincoln, UK) is a single-cylinder (horizontal), four-stroke spark ignition engine; it has a displacement of 7205 cm<sup>3</sup> and can provide a maximum power of 12 HP.

The Italian Society Langen and Wolf engine (Fig. 8), was manufactured by the Factory of Gas Engines “Otto”, Milan (Subsidiary of Langen and Wolf Gasmotorenfabrik Vienna) sometime around the end of the 19th century and the beginning of the 20th, and is a single-cylinder four-stroke engine; this rare model

**Fig. 8** Diesel engine  
Hille-Werke AG



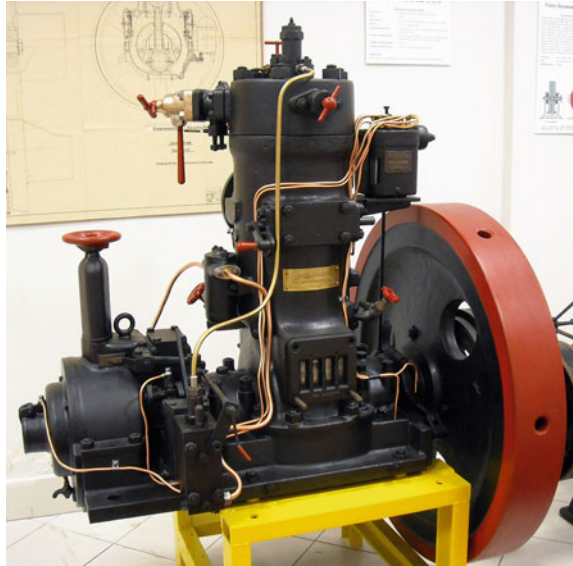
**Fig. 9** Gas engine Langen  
and Wolf (before restoration)



features an inverted vertical cylinder, has a displacement of  $1902 \text{ cm}^3$  and an archetypal valvetrain system with a sliding intake valve. This engine is also endowed with a very old ignition device which features a pilot flame and a “spool valve”, similar to that of a steam engine.



**Fig. 10** Diesel engine  
DWK K.Z.22



At the beginning of the 20th century, diesel engines gradually succeeded the alternative steam engine in stationary and marine power plants. The museum collection includes some pieces of early diesel engine, such as the single-cylinder DWK (Deutsche Werke Kiel) KZ22 (1927), a 2-stroke diesel with 16 HP at 525 rpm (Fig. 10), and the four-stroke single-cylinder Hille Werke, which features, similar to the early internal combustion engines, an overall design strictly derived from that of the contemporary alternative steam engine. The exhibit aims to highlight the development of machines and mechanisms which usually takes place by way of small technological degrees.

As previously mentioned, some of these engines were also used for didactical activities during courses on Fluid Machinery at the University of Palermo taken by several generations of students. For this reason, the DWK engine is displayed together with its original Ranzi hydraulic brake, showing the experimental and didactical configuration used for many years in the engine laboratory.

## 4 Aircraft Engines

After the first flight by the Wright brothers in 1909, the aviation industry underwent rapid development, and early aircraft piston engines, often strictly derived from the automobile industry, evolved to match aeronautic needs until the advent of jet engines at the end of the Second World War (Giger 1986). The museum has an important collection of aircraft engines, starting from the period of the First World War. The oldest aircraft engines are part of a batch of engines and flight instruments

**Fig. 11** Engine Mercedes D.IV



ceded by Germany, for study and research, in accordance with the Treaty of Versailles. Their arrival in Palermo was linked to that of Antonio Capetti, Professor of Aircraft Engines of the Polytechnic University of Turin (where he was rector years later), who held the chair of Thermal and Hydraulic Machines of the Royal University of Palermo in 1925 (Filippi 1983).

The oldest aircraft engine of the Museum collection is the Mercedes D.IV (Fig. 11), an in-line 8-cylinder engine produced by the Daimler-Motoren-Gesellschaft company during the First World War (Gunston 2006); it was the first German aircraft engine produced in a series equipped with a propeller speed reducing gear transmission. This engine was derived from the previous and highly successful 6-cylinder D.III engine (La Mantia 1926–1999). The D.IV passed the acceptance test in December of 1915, but due to its poor reliability, mainly because of the fragility of the crankshaft, which tended to break as a result of its excessive length, only 429 exemplars were produced. Daimler chose instead to continue the development of 6-cylinder engines, replacing the D.IV model with a completely redesigned engine, the D.IVa with 6 cylinders. The similar designation of the two engines is due to the rigid classification then in use in Germany, based on groups of delivered power (I–VI), where the first letter indicates the manufacturer (La Mantia 1926–1999). The engine features a constructive arrangement very widespread in that period (La Mantia 2006): crankcase in aluminium alloy, cylinders and heads in steel with thin wall welded steel cooling jackets. The pistons are made of two steel parts (top and skirt), screwed and welded. It has a displacement of 19,770 cm<sup>3</sup>, a compression ratio of 4.6:1 (due to the very poor knock resistance properties of gasoline of that period) and a maximum power output of 232 HP at 1440 rpm. This engine was fitted into reconnaissance aircrafts (AEG C.V and Albatros C.V), as well as bombers such as the Gotha G.II and AEG R.I).

During the First World War, Siemens-Halske, part of the Siemens group, was engaged in the construction of engines for the Luftstreitkräfte (German Air Force) (La Mantia 1926–1999). To meet the increasing demand for higher power output, especially at high altitudes, Siemens-Halske, in the autumn of 1916, began development of a new model, the Sh.III (Fig. 12). This was a bi-rotary radial engine (Giger 1986) with 11 cylinders with 240 CV max at 1000 rpm at sea level: unlike the contemporary radial engines, in the bi-rotary engine, the internal parts such as

**Fig. 12** Engine Siemens Halske Sh.IIIa



the main connecting rod, rods and crankshaft, rotated clockwise (seen from the front of engine) while the crankcase and the propeller (connected to the crankcase) rotated counter-clockwise (Nahum 1987). This particular, as well as fine, arrangement allowed for both reducing the propeller speed within its best efficiency range and increasing the power output by means of a higher combustion cycle frequency (that is, the sum of the absolute speed of two counter-rotary parts). A secondary advantage was the reduction of the mechanical stress state, because the organs of the motor reached, under normal conditions, a rotation speed of 900 rpm, which resulted, however, in an overall equivalent rotation of 1800 rpm in terms of supplied power. Furthermore, since the main rotating masses of the motor had to rotate with equal speed in opposite directions, the gyroscopic effect was partially reduced (compared to the other standard rotary engines of that period) with great benefit for the aircraft manoeuvrability. The Siemens Halske suffered, like other engines of that period, for the premature wear and the abnormal breakage due to a low supply of castor oil, used as a lubricant, and the subsequent use of “Voltol”, a substitute derived from mineral oils but of lower quality. Nevertheless, the Sh.III was a technically advanced engine for its time and was capable of remarkable performance in terms of maximum power output, specific fuel consumption and mass-to-power ratio (lower than 1 kg/HP). In September of 1918, a fighter plane, the Siemens-Schuckert D.IV equipped with the Sh.IIIa engine, recorded a remarkable performance for its time, reaching an altitude of 8100 m from the ground in 36 min (La Mantia 1926–1999).

The museum collection also includes a very rare Basse und Selve BuS.IV (1917/18) engine Fig. 13, which is probably one of the only two surviving. In 1906, Basse und Selve AG in Altena (Westphalia, Germany) was a renowned factory, with a leading position in the production of aluminium pistons and, like many other industries of the time, engaged in war production for the Idflieg (Inspectorate of Air Force) (La Mantia 1926–1999). At the end of 1915, Basse und Selve, overcoming the scepticism of the military authorities about the technology of aluminium pistons, obtained an order for an engine with 6 cylinders and 300 HP. Basse und Selve developed an early version of 20 L with 260 HP, using “Mercedes-type” cylinders (Gunston 2006) with screwed heads, 4 valves per cylinder and an overhead camshaft driven by gears. Only in October of 1917, after working through a series of problems that occurred with the first models, did Basse und Selve put into production the Bus.IV engine with a new displacement of 22.7 L and an output of 278 HP at 1400 rpm above sea level. Basse und Selve manufactured 330 engines, which were fitted for the largest military aircrafts of classes G and R: long-range bombers and reconnaissance aircrafts.

Between the two world wars, aircraft piston engines were continuously developed, reaching their maximum technical evolution during the ‘40s.

From that period, the Mercedes DB 605 can be considered to be one of the most advanced aircraft engines, along with the contemporary Rolls Royce Merlin (Gunston 2006). Daimler-Benz AG developed the DB 605 at the beginning of the ‘40s as a replacement for the previous DB 601 model. The 605 is an inverted 60° V engine with 12 cylinders, with a displacement of 35,700 cm<sup>3</sup>, and a maximum power output of 1475 HP at 2800 rpm (Fig. 14).

The most interesting technical part is represented by the injection and supercharging system. The engine actually has a Bosch in-cylinder direct injection system that, though not a novelty for a German engine, was a reliability and safety factor, avoiding dangerous backfiring and making the power output insensitive to the aircraft’s manoeuvring (especially during negative g-force flight conditions)

**Fig. 13** Engine Basse und Selve BuS.IV



**Fig. 14** Engine Daimler Benz DB 605

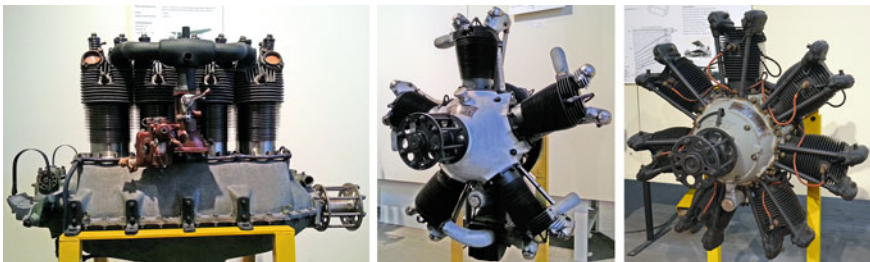


(Von Gersdorff et al. 2007). The supercharging system is equipped with a single-stage centrifugal compressor driven by the engine via a hydraulic coupling. This system is governed by an automatic controller, which continuously varies the impeller speed (by acting on the transmission ratio of the hydraulic coupling) depending on altitude and manifold pressure (La Mantia 1926–1999). The compressor speed increases with the flight altitude and reaches its maximum value at 5700 m.

The DB 605 equipped both Messerschmitt aircrafts, such as the Bf 109 fighters, and some of the most advanced Italian fighters of the Second World War, the Fiat G.55 and the Macchi MC.205.

Within the museum, the Italian production of aircraft engines is represented, from the '20s until 1945, by engines (Fig. 15) for light or training aircraft, such as the Colombo S.53 (1928–40), an inline-four-cylinder engine with 94 HP, the Farina T.58 ('30s), a 5-cylinder radial engine with a power output of 135 HP, and the Fiat A.50, a 7-cylinder radial engine, with a maximum power of 100 HP.

The collection also has two radial engines from the Second World War: a Fiat A.74 and a Fiat A.80. The Fiat A.74 R.C.38 (Fig. 16) was designed in 1935 by engineer Tranquillo Zerbi and prof. Antonio Fessia to fit fighter aircraft. This was an evolution of the US Pratt & Whitney R-1535 Double Star with 14 cylinders, whose FIAT had acquired the manufacture license. In order to simplify production, the same bore was adopted for the A.74 and A.80 to use certain identical components for the two engines: heads, pistons, valves, etc.



**Fig. 15** From left to right the engines Colombo S.53, Farina T.58 and FIAT A.50

The A.74 and the A.80 have a centrifugal compressor and an epicyclical Farman-type bevel gear transmission to drive the propeller. The FIAT A.74 engine is a double-row, with hemispherical combustion chambers and light alloy pistons; with its 14 cylinders, it has a displacement of 31,250 cc and a maximum power output of 840 HP at 2400 rpm at 3800 m above sea level. It was used in various fighters and bombers. The Fiat A.74, although still in use when its performance was already outdated, was appreciated by pilots and mechanics for its excellent reliability and ease of maintenance, even when forced to be fed with fuels of poor quality and operated in difficult climates, such as the heat of the Libyan desert or the cold of the Russian winter.

The Fiat A.80 engine (Fig. 17) was realised before the A.74, and its mass production started even though the engine was not yet fully set. The engine was approved on November 10, 1937, after passing the usual test run for a series of 150 consecutive hours on a test bench. Under real operating conditions, however, due to the poor quality of the fuels available in Italy during the war, despite many changes in the course of production, it suffered from a lower reliability than its smaller version, the A.74. This led to serious difficulties in its practical use, and when it came to satisfactory regularity and reliability of operation, the power of 1000 HP proved inadequate for the changes needed by the bomber line, still in rapid development during the war. The Fiat A.80 equipped the Fiat BR.20 and Breda BA.65 aircrafts, the CANT Z.509 seaplane, and the Savoia Marchetti SM.79 “Sparviero” and SM.87 aircrafts; it was also used by the Imperial Japanese for their Fiat BR.20 bombers during the Second Sino-Japanese War (1937–1945).

After the Second World War, turbojet engines replaced the aircraft piston engines, which are nowadays used only for light aircrafts. At the beginning of development of the turbojet engine various different systems and technical arrangements were experienced by many manufacturers (Gunston 2006). One of the main features which diversified the early turbojet was its type of compressor: the British manufacturer usually used centrifugal compressors while others, such as

**Fig. 16** Engine FIAT A.74  
R.IC.38



**Fig. 17** Engine FIAT A.80 R.C.41



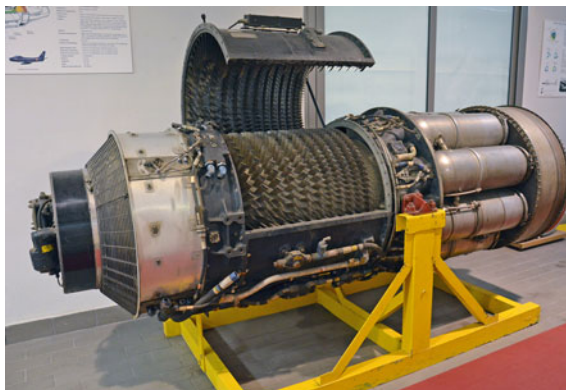
those in Germany (Heinkel, BMW and Junkers) or in USA, used axial flow multistage arrangements. After a few years, the latter became more widely spread since they entailed a lower engine front section.

The museum collection features engines with both compressor types. The de Havilland Ghost (Fig. 18) was one of the first turbojet engines developed in the UK during the last years of the Second World War. It was derived from the turbojet prototypes H1 and H2 by Frank B. Halford, one of the British pioneers of turbojet engines. During the development phase, de Havilland acquired the Halford company and renamed the H1 and H2 prototypes ‘Ghosts’ and ‘Goblins’, respectively. Both engines were characterized by a fairly simple setup: a single-stage centrifugal compressor, direct flow combustion chambers and a single-stage axial turbine.

**Fig. 18** Turbojet engine de Havilland Ghost: compressor and turbine impellers



**Fig. 19** Turbojet engine  
General Electric J47



The Ghost, completed in 1945, was rated at a maximum static thrust of 22,000 N at 10,250 rpm; its dimensions were 3314 mm long and 1346 mm of diameter, with a mass of 996 kg. The Ghost turbojet was used in the first exemplars of the De Havilland DH.106 Comet, which was the first commercial jetliner produced, as well as in many other military aircrafts.

The axial flow turbojet engines are well represented by the J47 (Fig. 19). It was developed by General Electric, starting from the former J35, and was the first axial-flow turbojet approved for commercial use in the United States. Between 1948 and 1956, when its production was ended, more than 30,000 units were built. Realized in various versions, with and without afterburners, it underwent constant development over the years, with considerable benefits in terms of power, reliability and increase in maintenance intervals. The J47 was used, in various versions, in many aircrafts, including the North American F-86 Sabre fighter and the Convair B-36 Peacemaker strategic bomber. The F-86 Sabre has been used in Italy since 1956, including by the “Acrobatic Team” of the Aeronautica Militare (the Italian Air Force).

## 5 The FIAT G.59

The Museum collection is continuously improved by means of several acquisitions, one of the most important would certainly be the FIAT G.59 aircraft (Fig. 20), a two-seater trainer aircraft of the ‘50s, one of only five complete copies surviving today, and therefore one of the most valuable items in the museum’s collection.

The Fiat G.59 was one of the last high-performance aircraft equipped with a piston engine, as well as serving as a symbol of the re-birth of the post-war Italian aeronautical industry. In 1947, the engineer Giuseppe Gabrielli, who was one of the most important designers of Italian aircraft, developed the G.59 from a strict approximation of the FIAT G.55 Centauro, which was considered one of the best Italian fighter aircraft of the Second World War. The G.59, which was always





**Fig. 20** FIAT G.59 4B

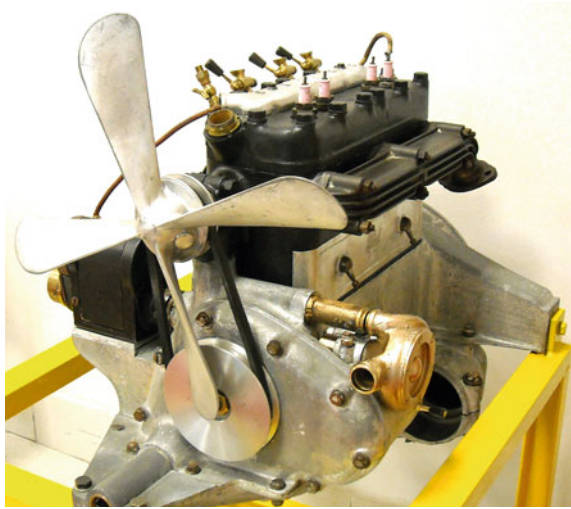
appreciated in Italy, as well as in other countries, had been produced by Fiat since 1950, mainly for use, until 1965, by the Italian Air Force as an advanced trainer aircraft. It has a wingspan of 11.86 m and a length of 9.50 m, with an unloaded mass of 2850 kg. Thanks to its engine, the V-12-cylinder Rolls Royce Merlin (version 500-20) (Gunston 2006), capable of providing a maximum power of 1660 HP to a four-blade variable pitch propeller FIAT Hamilton 5010, the aircraft could reach a top speed of 609 km/h at an altitude of 6400 m above sea level, and a ceiling of 12,100 m; it had a ferry range of 762 km to 5600 m under normal conditions, or of 1352 km at 460 km/h at an altitude of 5500 m, using the two releasable external tanks. The Museum's Fiat G.59 4B, which has the military serial number 53,530, after completing its service in the Second Air Region (Rome) of the Italian Air Force, was purchased in 1964 by the former Institute of Aeronautics of the University of Palermo and is today displayed after having undergone a thorough restoration in the Museum's workshop.

## 6 Automotive Engines

The for automotive section hosts engines for motor vehicles of various types and different applications, most of which were gradually acquired over time to be used for research and educational purposes, as is, indeed, still the case, following in the wake of continuous technical and scientific development.

The oldest of them is the Fiat type 101 engine (Fig. 21), produced from 1919 to 1926 for the Fiat 501: a 4-cylinder with an aluminium crankcase and cast iron cylinder block and head, it has a displacement of 1460 cm<sup>3</sup> and delivers 23 HP at 2600 rpm.

In chronological order, it follows the FIAT type 114 engine (1929–1932), mounted on the Fiat 514 and Fiat 515 models: with a displacement slightly lower than the FIAT 501, the power supplied climbed to 28 HP at 3400 rpm; moreover, it

**Fig. 21** Fiat 101 engine

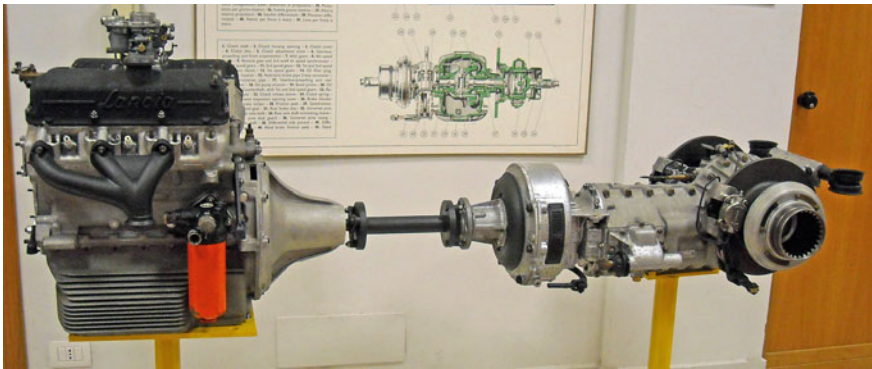
passed from the magneto ignition system to the modern inductive discharge ignition.

After the Second World War, in 1947, the president of Fiat appointed engineer Dante Giacosa to design an executive car suitable for the USA market. Rejecting the idea of a V-6 cylinder, the solution of an V-8-cylinder was then chosen, a project that was completed in January 1950. A first prototype was designed for a cruise car, but few time later, it was decided to develop the engine for a sport car; in view of the new purpose, and in light of the results obtained in the preliminary tests, the designers completely redesigned the engine heads and the distribution system in order to increase the power. The engine (Fig. 22), an 8 cylinder V 70°, having a crankshaft with three main bearings and cranks at 180°, delivered the power of 105 HP at 5600 rpm with a displacement of 1996 cm<sup>3</sup>. After positive results were obtained, it was decided to begin development of the Fiat 8V chassis. Between 1952 and 1954, the Fiat 8V was produced in a workshop dedicated to experimental manufacturing, with a total production of only 114 units, although many groups of chassis-engine were sold to external coachbuilders who built special versions, including the Fiat 8V Zagato, with a typical sport setting. A great number of 8V, especially those prepared by Zagato, were used in several sporting events, in which they met with much success. Among these, the most noteworthy are: the victory of the Targa Florio in 1955 (1st 8V Zagato, 2nd Fiat 8V), the victory of the Grand Prix at Avus in Berlin in 1955 (8V Zagato) and five consecutive Italian 2000 cm<sup>3</sup> class championships in speed (1954–1958).

The engine of the Flaminia 2500 (Fig. 23) is of the same period, a 6-cylinder 60° V with 2458 cc that the Lancia company of Turin devised in order to create a very compact engine, free of all the vibration problems that characterized the narrow V 4-cylinder engines of previous production. The engine was derived from the V6 engine of the Lancia Aurelia and was subsequently subjected to continuous



**Fig. 22** Fiat 8V engine



**Fig. 23** Lancia Flaminia 2500, the engine with powertrain (transaxle arrangement)

development (also for sport competitions), including the engine of the Lancia Flaminia, 102 HP at 4600 rpm, which remained in production (with several changes) from 1957 until 1969, and which features a fine “transaxle” arrangement for clutch-gearbox-differential. The 60° V6 arrangement had considerable success, and was adopted by many other manufacturers; it is still, today, one of the most spread in the automotive field.

In the same year, the Alfa Romeo company of Milan put into production the engine type 00100 (1960–61), a 4-cylinder 1290 cm<sup>3</sup> which developed a maximum power of 62 HP at 6500 rpm (Fig. 24). It had a cylinder block, head and oil pan in aluminium and wet replaceable cylinder liners. This engine was produced for a long time in different versions, from Giulietta Berlina (sedan) to Giulietta spider.

FIAT responded to these cars by putting the Fiat 1300 sedan on the market, and then a station wagon model, both equipped with the FIAT 116.000 engine, a 4-cylinder with 1295 cm<sup>3</sup> and a power of 65 HP at 5200 rpm.

The Museum's collection also includes high performance engines as the Fiat Dino 2000 and its later evolution Fiat Dino 2400, which resulted from the collaboration between Fiat and Ferrari, and were used in sports cars produced by both manufacturers in the '60s and '70s. The new rules adopted by the FIA in 1964 for the 1967 season specified that, to race in the F2 championship, every car had to be equipped with an engine already produced in a series of at least 500 individuals in 1966. It was not necessary that the displacement be the same; it was enough that the same crankcase was used. In those years, Ferrari was in no condition to produce a street car in that amount. The company's business was divided mainly between production of exclusive grand touring cars in small series and by almost handmade methods, and sport competitions. Starting from these considerations, Enzo Ferrari began negotiations with Giovanni Agnelli, chairman of Fiat, which developed into an agreement, presented to the press in 1965, when Ferrari undertook the design of a V6 engine in collaboration with Fiat. The latter undertook construction of a new car equipped with the V6 engine in a sufficient number to allow Ferrari the use of

**Fig. 24** The engine of the Alfa Romeo Giulietta 1300



the engine for F2 championship. In the design of the engine, Ferrari took advantage of what had been done since the mid-'50s, when the development of a six-cylinder 65° V engine had begun, born out of the work of engineer Vittorio Jano and Alfredo Ferrari, known as Dino, son of the founder of the team. After the untimely death of the latter, the V6 Ferrari took his name and had great luck in the following years: with continuous displacement development from 1500 to 2000 cm<sup>3</sup>, it was mounted on many Ferrari racing cars.

The final product of the Fiat-Ferrari collaboration was the Fiat Dino Spider 2000, equipped with an engine (Fig. 25) of typical sport setting, adapted for mass production by the engineer Aurelio Lampredi of FIAT. It had a displacement of 1987 cm<sup>3</sup>, delivered a maximum power of 160 HP at 7200 rpm. The engine featured a light aluminium construction, two overhead valves per cylinder controlled by two overhead camshafts in each cylinder bank, driven by double chain and gears; the fuel system has three twin-choke Weber 40 DCN carburetors. After exceeding 500 units, the engine, properly tuned up, was ready to run in 1967, allowing Ferrari to win the world championship of the 1968 F2 with the Dino 166 F2. After the Fiat Dino Spider, the Fiat Dino Coupe was introduced, and Ferrari also began production on a road sport car under the Dino brand. The new car, called the 206 GT, used the same V6 engine, but with a rear mid-engine-gearbox transversely-mounted configuration.

In 1969, the Fiat replaced the engine Dino 2000 with a new version of 2400 cm<sup>3</sup> (the Fiat Dino 2400, Fig. 26), with engine block in cast iron rather than in aluminium, because the previous block had proved to be rather sensitive to rapid temperature changes, which tended to create deformations in the engine block. These changes guaranteed a greater reliability and also yielded an engine more suitable for road use: along with the increase in power (from 160 to 180 HP), the new 2400 engine had a torque greater than the 2000 model (from 172 to 216 Nm), and in particular, at a lower engine speed (4600 rpm instead of 6000). In addition to equipping the Fiat Dino 2400 Spider/Coupe and the Dino 246 GT/GTS, the 2400 V6 was used in the Lancia Stratos, whose racing versions met with great success and prestige in both International and individual national championships, winning the world Rally championship Group 4 in the 1974, 1975 and 1976 seasons.

Since the end of the '60s Bosch started to develop innovative injection systems electronically controlled which progressively widely spread in automotive field

**Fig. 25** FIAT 135B: the Dino 2000 engine



**Fig. 26** FIAT 135C: the Dino 2400 engine



thanks to their prerogative of fine engine control management, with benefits on both engine efficiency and pollutant emissions reduction.

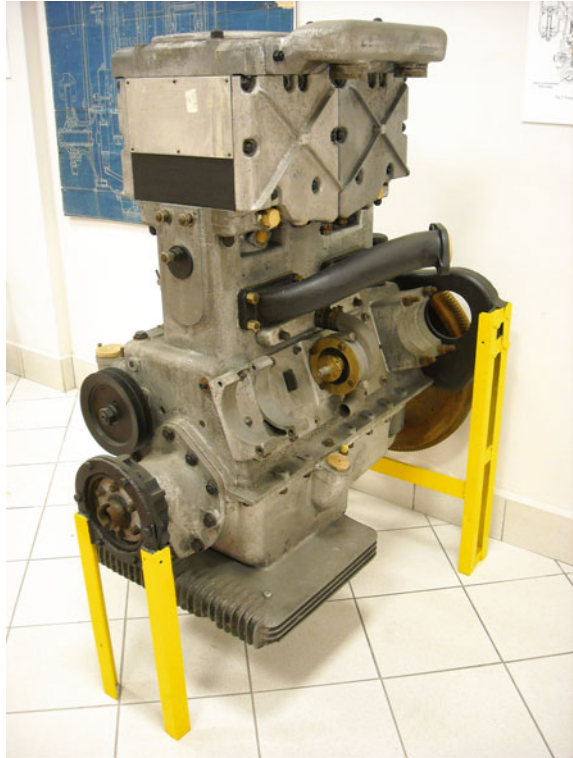
The Museum collection has some engines of recent production, endowed with electronic injection system, such as an Alfa Romeo engine 4-cylinder boxer (Fig. 27). This type of engine has been produced by Alfa Romeo from 1968 to 1994, in various versions and for many cars. The engine displayed at the Museum is the latest model, equipped with electronic injection system. The engine features a cast iron cylinder block, heads and pistons in aluminium, and 4 valves per cylinder with hydraulic tappets operated by two overhead camshafts in each cylinder bank, driven by toothed belts. The displacement is of 1712 cm<sup>3</sup> and the maximum power output of 133 HP at 6500 rpm. The engine was used for the latest version of Alfa Romeo 33 and for the Alfa Romeo 145 and 146 models.

In the section for heavy traction engines, an important role is certainly played by the Lancia Junkers type 89 engine, and not only for historical reasons, but also for its special technical features. The Lancia-Junkers type 89 (Fig. 28) is a two-stroke

**Fig. 27** Engine Alfa Romeo boxer 1700 16 V IE



**Fig. 28** The Lancia-Junkers engine type 89 for heavy trucks



engine, with two cylinders in line and two opposing pistons for each cylinder, having two different values of stroke: 150 mm for the upper one and 100 mm for the lower one; the displacement is of 3181 cm<sup>3</sup> and the maximum power of 64 HP at 1500 rpm; the basement and cylinder bodies and heads are made of aluminium, while the cylinder barrels are steel. The distribution system uses automatic intake valves; the feeding system is by direct mechanical injection with two injectors fed by a reciprocating pump with two plungers (injection pressure 500 bar), and the air wash pump with two pistons, with a bore of 150 mm, is fixed to the upper pistons of the engine. It was produced by Lancia in the years between 1932 and 1938, when it acquired the manufacturing license to this diesel engine, which was developed in Germany by Junkers. The truck equipped with the Lancia-Junkers type 89 engine was called the “Ro” and was produced in various versions, also for military applications. The production of the Ro ended in 1939, but many specimens took part in the Second World War. After the war, the surviving specimens of Ro (mostly of military origin) were used for civilian applications. In 1938, Lancia abandoned the particular two-stroke engine arrangement and the Ro was joined by the “3Ro” equipped with an ordinary four-stroke 5-cylinder diesel engine.

The museum also exhibits some motorcycle engines, including a 250 Frera VL (1926-1932), a Benelli 500 VL (late 30s) and other less conventional pieces, such

as a Wankel engine and an experimental prototype of a rotary engine with toroidal combustion chambers, realized at the Institute of Machines of the University of Palermo, in the early '60s.

## 7 Scientific and Didactic Devices

The Museum has an important collection of scientific equipment which was used over time in the laboratories of Machines and Applied Mechanics.

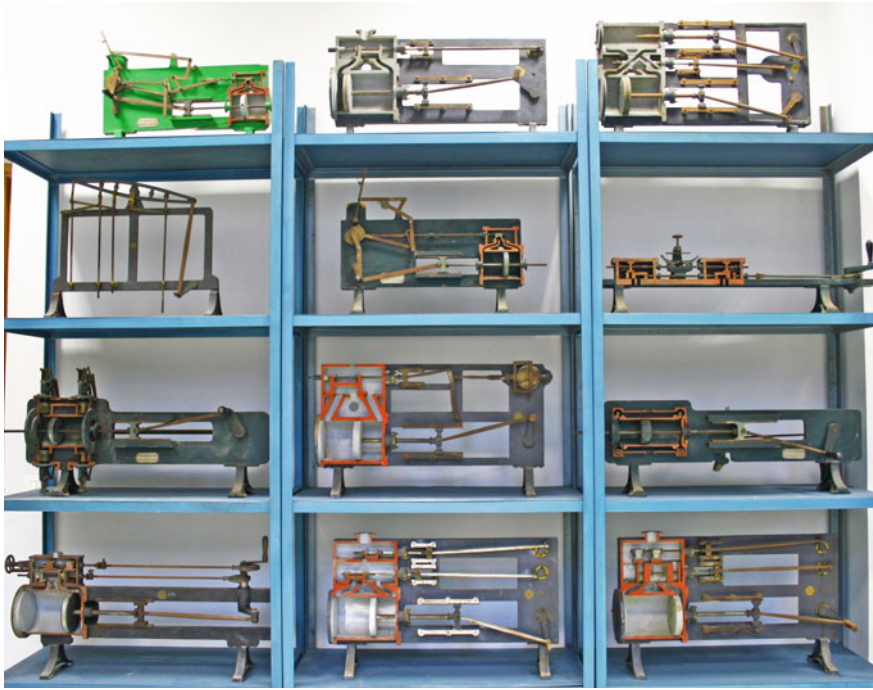
There are several devices for the analysis of mechanical vibrations, for measurement of pressure, temperature and velocity, for the exhaust gases analysis and several dynamometric brakes for the measurement of engine power.

The collection also includes more than one hundred didactical models are preserved, in metal or wood, which illustrate elementary machines, mechanisms, transmission components, mechanisms for the description of the coupling profiles between mechanical elements, and various steam engine types, which were widely



**Fig. 29** Applied mechanics didactic models





**Fig. 30** Steam engines didactic models

spread in the 19th century for various applications. These models (Figs. 29 and 30), which were built for educational purposes by specialized German and Italian companies in the second half of the 19th century, mostly belonged to the Cabinet of Applied Mechanics of the Royal School of Application Engineers (Filippi 1983).

Even today, some of them are used as teaching tools, as they are useful means for the clear explanation of some of the most important principles of mechanics, which have remained unchanged over time.

## References

- Filippi F (1983) Dall'elica al getto. Associazione Industriali Metallurgici Affini (From the airscrew to the jet. Society of Metallurgic and Alike Manufacturers). Editions EDA, Torino
- Genchi G, Sorge F (2012) The Rotary Aero Engine from 1908 to 1918. History of mechanism and machine science. Springer, The Netherlands, pp 349–362. doi:[10.1007/978-94-007-4132-4](https://doi.org/10.1007/978-94-007-4132-4), ISBN: 978-94-007-4131-7, ISSN: 1875-3442
- Giger H (1986) Kolben-Flugmotoren. Motorbuch Verlag, Stuttgart
- Gunston B (2006) Development of piston aero engines, Patrick Stephens
- La Mantia FP (1926–1999) Inventario Storico dell'Istituto di Macchine dell'Università degli Studi di Palermo (Historical catalogue of the Institute of Machines of the University of Palermo)

- La Mantia FP (2006) Contributi per una storia della Facoltà di Ingegneria di Palermo (Contribution to the history of the Faculty of Engineering of Palermo), vol 2. Editions Fotograf, Palermo
- Nahum A (1987) The rotary aero engine. HMSO Books, London
- Von Gersdorff K, Schubert H, Hebert S (2007) Flugmotoren und Strahltriebwerke (Aircraft motors and jet engines). Bernard und Graefe Verlag, Bonn

# History of the Trains Used on the Spanish Railway Line Madrid–Almorox

Daniel Fernández Caballero, Víctor Rodríguez de la Cruz,  
Julián Martín Jarillo and Manuel Esperón Miguez

**Abstract** Nowadays, there is a huge amount of interest in the new high-speed railway lines in Spain. However, there is not much public investment in conventional railway lines. This is not a new phenomenon in Spain's recent history. This work undertakes analysis of an old metric railway line from Madrid to Almorox. The design of the line was completed, and portions of the infrastructure, such as bridges and viaducts, were built. Not a single train has ever completed a run along this line. This work analyses the railway line from both technical and historical points of view.

## 1 Extended Summary

The original name of the Madrid–Almorox railway line was “Madrid–Villa del Prado”. It was a metric railway built by a Belgian enterprise managed by Armand Rouffart. There were three different sections: Madrid–Navalcarnero, Navalcarnero–Villa del Prado and Villa del Prado–Almorox. The construction work started in 1887; the first two sections were finished in 1891 and the last one in 1901. The whole line was built in metric gauge.

---

D. Fernández Caballero (✉)  
Experimental Mechanics, Calculation and Transports (MECATRAN),  
Universidad Carlos III de Madrid, Av de la Universidad, 30, 28911 Madrid, Spain  
e-mail: danferna@ing.uc3m.es

V. Rodríguez de la Cruz  
Mechanical Engineering and Manufacturing Department, E.T.S.I. Industriales,  
Universidad Politécnica de Madrid, José Gutiérrez Abascal, nº 2, 28006 Madrid, Spain  
e-mail: v.rodriiguez.delacruz@gmail.com

J. Martín Jarillo · M. Esperón Miguez  
Mechanical Engineering and Manufacturing Department, E.T.S.I. Industriales,  
Universidad Politécnica de Madrid, José Gutiérrez Abascal, nº 2, 28006 Madrid, Spain  
e-mail: julianmjarillo@gmail.com

M. Esperón Miguez  
e-mail: m.esperonmiguez@cranfield.ac.uk

This railway line suffered many economic and political problems. The Belgian enterprise that developed the line signed an agreement of operation and maintenance with the Spanish Armed Forces in 1891; however, this financial arrangement only lasted three years. In 1927, the Spanish Government decided to acquire the railway line, with the intention of extending it by roughly another 250 km; construction started, but the advent of the Spanish Civil War put a stop to those plans.

In January of 1966, the section from Navalcarnero to Almorox was closed. In 1970, RENFE (Red Nacional de los Ferrocarriles Españoles) announced the construction of a new line, Madrid–Móstoles, in the Iberian gauge, so the old metric line between Madrid and Navalcarnero was closed on July 30th, 1970. Although nowadays, the old line is completely dismantled, some of its stations are still being used. For example, the section from Empalme to Móstoles is part of RENFE's current Iberian gauge line, Móstoles–El Soto–Atocha-Fuenlabrada.

During the construction years, huge budgets were allocated for railroad infrastructure. Nineteen railway stops, fifteen bridges and ten crossing gates were built. Two of the most important railway infrastructures were the Guadarrama River Bridge and the Alberche River Bridge.

This work also analyses the different kinds of rolling stock used in this historic line. In the 19th century and first part of the 20th, steam locomotives were used. The first five locomotives were manufactured by Krauss in Munich in 1890. These machines had three driving axes (0-6-0T configuration). Some years later (1908 and 1912), another two identical machines were bought. In 1893, a Belgian locomotive was bought from Couillet; an articulated 0-4-4-0T Mallet locomotive class with double expansion traction system, it was one of the first locomotives of this type used in Spain.

Recent research shows that, after the Spanish Civil War, a locomotive from the Basque Country was used. This locomotive was manufactured in 1892 by Nasmith and Wilson, and it had previously been used on the Vasque-Navarre line. In the next century, three more locomotives were bought from MTM (Maquinista Terrestre y Marítima), all of them 1-3-1T class.

In 1957, the first diesel locomotives were used. These two locomotives were manufactured by Batignolles in France and assembled in Spain by CAF (Construcciones y Auxiliar de Ferrocarriles). They had three axles and were 5942/4 and 5947/8 class, respectively. Their maximum speed was 70 km/h. Some years later, a diesel-electric locomotive was bought from Creusot. Neither the Batignolles nor the Creusot worked properly on this line.

In 1963, three Billard coaches were used on this line. These coaches had been used previously on the “Secundarios de Castilla” and “Málaga a Fuengirola” lines.

## 2 Short Story of the Line

The original metric railway project built by the Belgian Rouffart's enterprise was to be a railway from Madrid to Villa del Prado, another municipality close to Madrid, which would later be extended to Almorox (province of Toledo). The Madrid–Navalcarnero



**Fig. 1** Railway route from Madrid to Almorox

segment measured 31,532 km, the Navalcarnero–Villa del Prado segment, 30,230 km and the Villa del Prado–Almorox segment, 11,661 km. So, “Compañía de FFCC de Madrid a Villa del Prado y Almorox” was established. The railway route started in Madrid, at the Madrid-Goya station, on the bank of the Manzanares River and only a slight distance from the Madrid city center. It left Madrid, stopping near the cities of Alcorcón, Mostoles and Villaviciosa de Odón. Then, it went past the small country villages of Navalcarnero, Villamanta, Mérida, Albarche, Rincón, Villa del Prado and Alamin until, having spanned the full 73,423 km of its run, it would arrive at the nineteenth and last station at Almorox (Fig. 1).

The promoters also considered three possible extensions of the line: from Rincón to Sotillo de la Adrada (authorized in 1894), from Navalcarnero to La Puebla de Montalbán (authorized in 1907) and from Almorox to Talavera de la Reina, but none of these projects was carried out. This last extension was an attempt to join the Madrid–Almorox line with the Madrid–Cáceres–Portugal line, which was built in Iberian gauge (1668 mm), opened in 1880 and owned by the MCP Company. MCP came early and got authorization for the Almorox–Talavera de la Reina section in 1908, but works never got started. Moreover, this fact impeded other companies from carrying out the project (Fig. 2).

The line’s business management had several phases, a byproduct of the aforementioned political and economic problems that plagued it. The agreement between the Belgian company and the Spanish Armed Forces in 1891, according to which the latter would operate and maintain the line, dissolved in June of 1894, when the company filed for bankruptcy.

In 1921, the company was sold to Bank Urquijo, its last private owner until 1927, when General Primo de Rivera’s Government decided to acquire the Madrid–Almorox railway. An ambitious plan was devised to extend the line to Villamanta, San Martín de Valdeiglesias, Arenas de San Pedro (a province of Ávila) and Plasencia (a province of Cáceres), a project that was anticipated as taking 20 years to complete. Construction began, but in 1936, the Spanish Civil War broke out, and all work on this new railway line was stopped, even though a significant amount of infrastructure had already been finished.



issued in 1965 said that the infrastructure consisted of a single line railway and that 15 km required ballast to be reinstalled. There was little freight traffic, although passenger traffic grew. At that time, the public investment that the railway required was not available. The 1965 report advised that the section closest to Madrid only be used as a metropolitan or subway railway. So, in that year, trains only circulated from Madrid to Navalcarnero. The section of the line between Navalcarnero and Almorox was closed down.

In the 1970s, the Spanish Government approved a double electrical line with Iberian gauge between Madrid and Móstoles. This was the main cause of the end of the Madrid–Navalcarnero stretch of the original Madrid–Almorox line. The new line still shared some stretches with the original line, for example, the Empalme–Cuatro Vientos–Alcorcón stretch.

In the 1990s, there were two important changes, the first one being a tunnel to Embajadores (in the city centre of Madrid); the other important change was the extension of the main line toward the suburbs. This line is called Móstoles–El Soto–Atocha–Fuenlabrada of Cercanías de Madrid.

So, as has been previously stated, although the line no longer exists, some parts of it, such as certain stations or the original outline, are part of the current rail network of the Madrid region.

### 3 Some Economic Data on the Madrid–Almorox Line

An economic analysis of the line is just as important as the story behind its genesis or the different kinds of trains that it employed. The economics can help us to understand why this railway line does not exist nowadays. The main parameters that have been compared are:

- Speed, time and distance of the line between the years 1912 and 1976 (as shown in Fig. 4; Table 1).
- Economic profit and cost-income ratio from 1893 and 1964 (as shown in Fig. 5).

It was not possible to obtain all the information we sought for Table 1; Figs. 5 and 6 to be complete. In those cases in which the information was unavailable, a blank space has been used. Economic data for the period between 1936 and 1939 could not be obtained due to the Spanish Civil War. Also, while we were able to find the cost-income ratio (%) for the period between 1936 and 1939, the cost and income for each individual year were not available. All economic data are in “pesetas”, the currency that preceded the Euro in Spain.

Table 1; Fig. 5 show the average speed and travel time of the line from 1912 to 1976. It is important to point out that there is no variation, neither in the average speed nor in the distance of the line, between 1912 and 1960. The 1950s and 1960s are important in Spanish economic history because of the change in economic model. At the end of the 1950s, economic growth in Spain reached pre-Civil War levels. There was a 50 % reduction in travel time thanks to an increase of 50 % in



**Fig. 4** Crossing between suburbano (*downstairs*) and almorox (*upstairs*)

**Table 1** Travel time, distance and average speed between 1912 and 1976

Year	Travel-day-direction	km	km-day	Time (min)	Average speed (km/h)
1912	3.0	74	444	220	20.18
1935	3.0	74	444	200	22.20
1946	2.0	74	296	220	20.18
1950 <sup>a</sup>	5.0	75	750	220	20.45
1960 <sup>a</sup>	5.0	74	740	105	42.29
1965	6.0	74	888	105	42.29
1970 <sup>b</sup>	7.5	32	480		
1976	138.0	12	3312	15	48.00

Railway line Madrid–Almorox and Móstoles–Aluche

<sup>a</sup>1950 and 1960: 6 trains during week days and 4 during holidays

<sup>b</sup>1970: 8 trains during week days and 7 during holidays

the mean speed due to the introduction of diesel traction into the line. In the 1970s, as stated in the short story of the line, there was a significant reduction in the length of the line. The length was 32 km in 1970, and a mere 12 km by 1976, considerably shorter than the original 74 km. In the 1970s, the line could no longer accurately be called “Madrid–Almorox”, “Móstoles–Aluche” being far more accurate. The time it took to travel the 12 km of the line was 15 min, setting the mean speed near 50 km/h.

Another important analysis in the economic results of the line is shown in Fig. 5. There are four distinctive time periods:

- Belgian enterprise (1890–1921). This period was marked by a constant cost/income ratio; however, there are certain years for which there are no data. There was also an increase in cost and income.



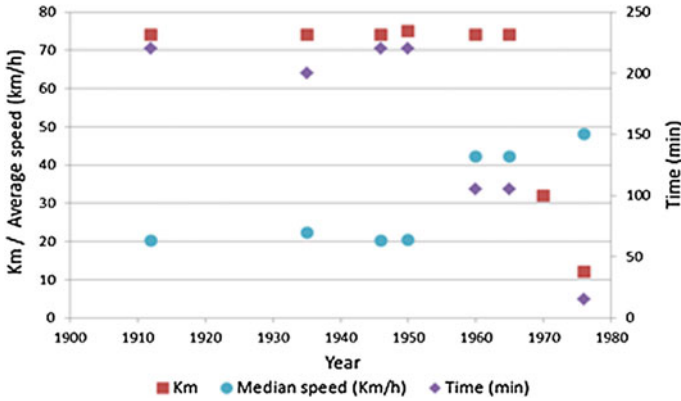


Fig. 5 Time and average speed between 1912 and 1974

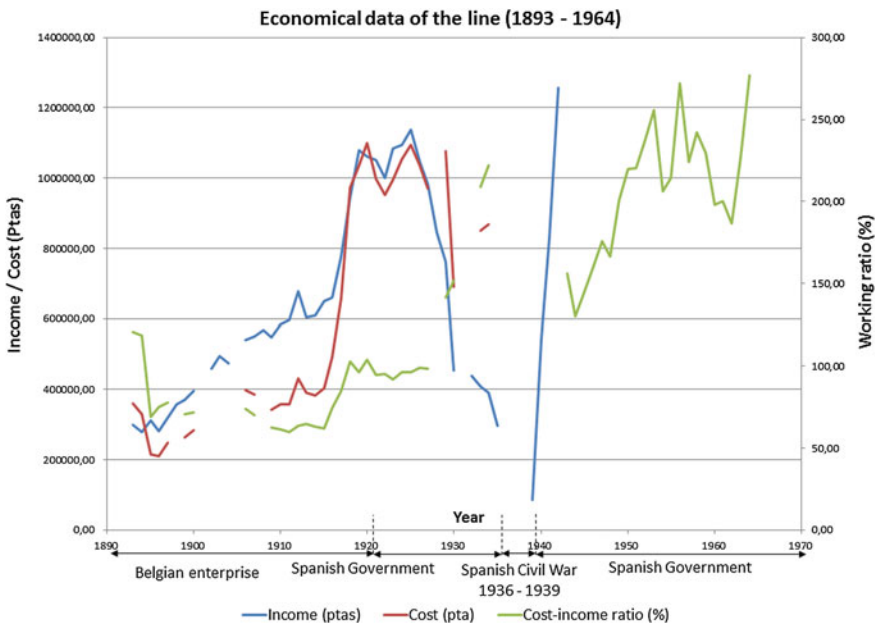


Fig. 6 Evolution of income, cost and cost-income ratio between 1893 and 1964

- First period of Spanish Government management (1921–1936). There was a huge increase in both cost and income, but not in their ratio.
- Spanish Civil War (1936–1939). There are no data from that time period.
- Second period of Spanish Government management (1936–present day). There are only working rate data for this time period. Between 1944 and 1956, there was an increase of 210 % in the cost-income ratio that resulted in the line being closed.

## 4 Civil Infrastructure

The original line had seventeen stations, fifteen bridges and ten level crossings. There were two significant civil infrastructures, the bridge across the Guadarrama River and the bridge across the Alberche River.

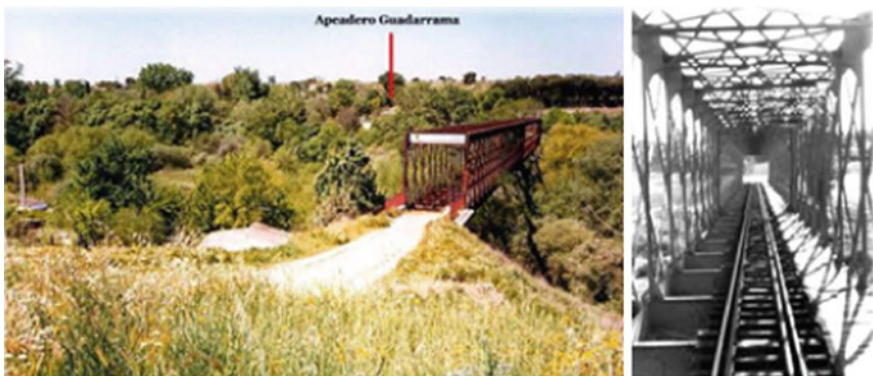
The Guadarrama River Bridge is a box steel bridge built at the end of the 19th century. It is located at kilometer point 23,900, near the Río Guadarrama station. It has heavy stone foundations, thanks to which it is still standing today (Fig. 7).

The other main bridge crossed the Alberche River (Fig. 8), but that one no longer exists. FEVE sold the steel box some years ago. Nowadays, only its central foundation can still be seen.

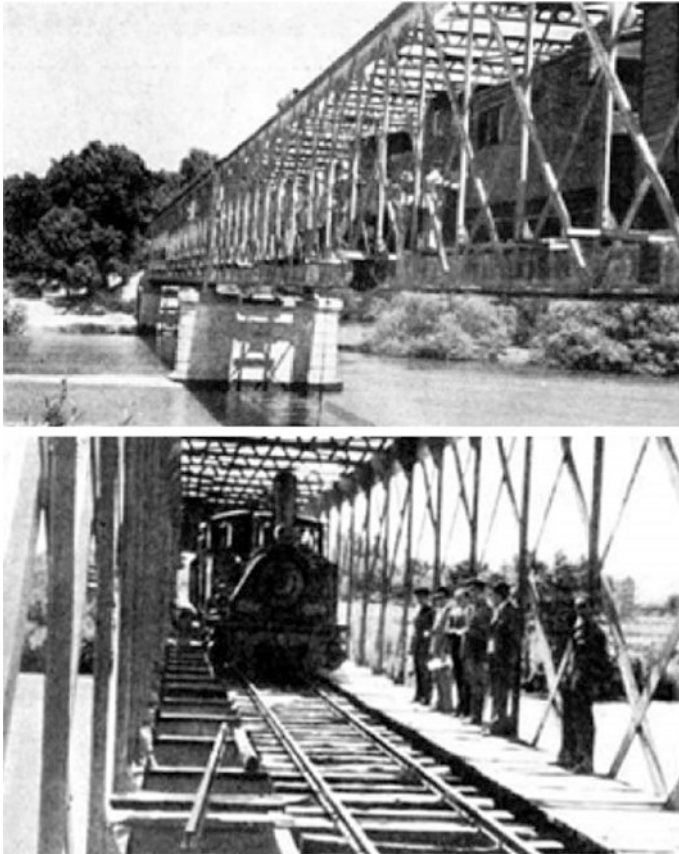
## 5 Story of the Rolling Stock Used on the Madrid–Almorox Line

From the time this line was initiated, there were steam locomotives on it. The first five units were manufactured by Krauss at Munich. The first of these five locomotives was named “Madrid” (with manufacture reference 2296); the second, “Guadarrama” (with reference 2299); the third, “Navalcarnero” (with reference 2298); the fourth, “Alberche” (with reference 2297); and the fifth “Villa del Prado” (with reference 2230). They had three axles coupled (0-6-0T) with metric distance between their wheels (Fig. 9).

In the 1910s, there had been an increase in traffic, so it was necessary to acquire new locomotives. Two new locomotives were bought from Krauss. Number 9 was called “Méntrida” in 1908 (with manufacture reference 5873) and number 10 was called “Almorox” in 1912 (reference 6703).



**Fig. 7** Contemporary (*left*) and vintage (*right*) photos of the bridge across the Guadarrama River



**Fig. 8** Vintage photos of the bridge across the Alberche River

Three other identical locomotives were used on the line before the Spanish Civil War. They were numbered 6, 7 and 8 and were called “Alamín”, “Móstoles” and “Villamanta”. They were second-hand, having been previously used on the line from Fuengirola to Málaga until 1934. But there was also another set of locomotives numbered 6, 7 and 8, called “Zaldívar”, “Vergara” and “Ermua”, which had been used on the line from Durango to Zumárraga. These locomotives with, configuration 0-6-2T, were manufactured by Couillet.

Locomotive number 11 was called “Zardo”. It was manufactured in Belgium by Couillet in 1893. Its manufacture reference was 1076 and it had a configuration 040 + 040T, with a Mallet system. The essence of this architecture combines articulation of the locomotive and compound steam use. That system consisted of two motor units with both high and low pressure cylinders. That design allowed for greater precision and also better curve stability. It was one of the first locomotives in Spain with a dual expansion traction system.

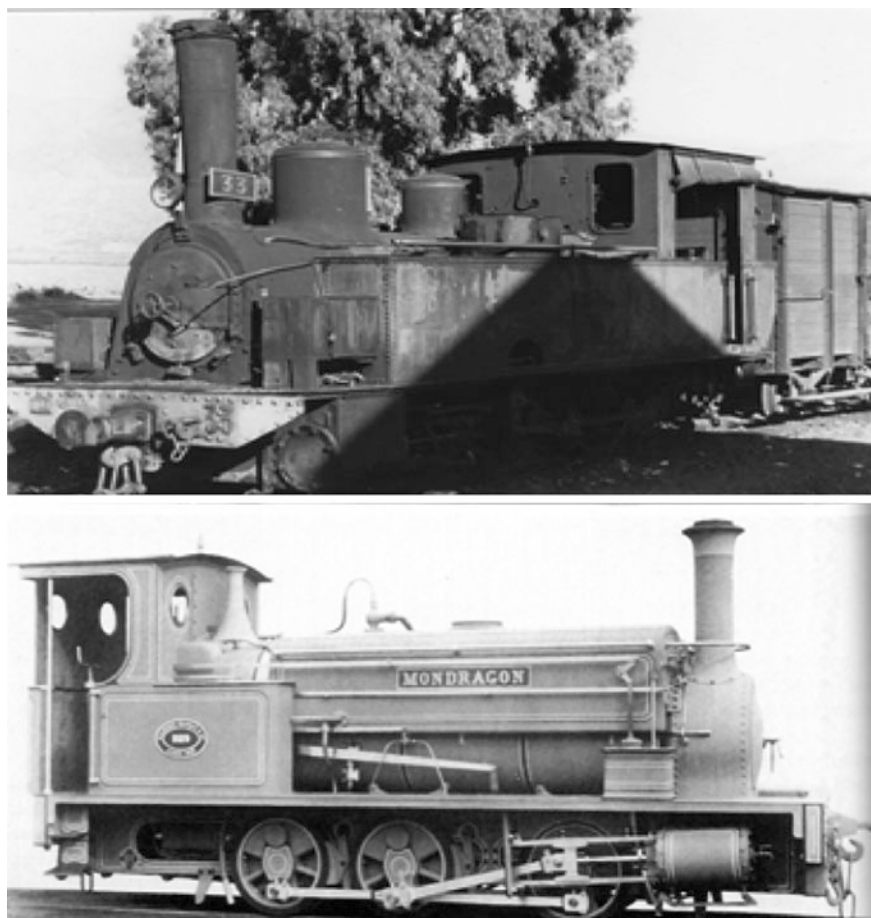


**Fig. 9** Locomotive Krauss number 4, “Guadarrama”, at the Goya Station and locomotive Falcon number 4, “Vitoria”

Recent research indicates that, after the Civil War, a Nasmith & Wilson locomotive was moved from the Vasco–Navarro line to the Madrid–Almorox line. That locomotive was called “Ibaizábal”, it had a configuration 2-6-0T and was manufactured in 1892 (Fig. 10).

Three other locomotives were used on this line. They were manufactured by Maquinista Terrestre y Marítima (MTM) in 1892. Their manufacture reference was 143, 144 and 145, they were numbered 13, 14 and 15, and were named “Ibaizábal”, “Vasconavarra” and “Tarazona”. These three units had been previously used on the railway line from Fuencarral to Colmenar Viejo and also by the Vasco-Navarro railway company.

In 1957, diesel technology replaced the old steam locomotives. Two locomotives were used on this line thanks to a modernization plan for a narrow gauge railway by



**Fig. 10** Locomotive Couileet 030T Fuengirola and locomotive M&W Mondragón, Fred W. Harman

the Spanish public administration. These locomotives were diesel-hydraulic, manufactured in France by Batignolles and assembled in Spain by CAF. They produced 500 BHP, had three axles coupled by connecting rods, and their maximum speed was 70 km/h. Their manufacture references were 1204 (5943/4 was the CAF reference) and 1208 (5947/8 was the CAF reference).

Another diesel electric locomotive, with 675 BHP, was used. In this case, it was a Creusot locomotive, assembled in Spain by SECN (Sociedad Española de Construcción Naval) en Sestao (Vizcaya). It did not work as well as the Batignolles locomotives. All of them were dismantled after a few years (Table 2).

Two MAN diesel railcars were used for tourist transportation in 1956. Those locomotives came from the closed line from Ceuta to Tetuán. The engine was manufactured by MAN with reference W6V 14/16L. It had a power of 170 BHP

**Table 2** Technical features of Krauss, Creusot locomotives and Man railcars

	Krauss	Creusot	Man	Billard
Type of locomotive	Steam	Diesel-electric	Diesel-hidromechanic	Diesel motor
Number built	7	1	2	1
Numeration	1–5, 9 and 10	3	2201 and 2202	2102 and 2144
Build year	1890, 1908 and 1912	1957	1956	1958
Engine	–	40 6LXS	W-6V 14/18-L	Pegaso 9105/31
Configuration	0-6-0T	Bo'Bo'	Bo'Bo'	Bo'Bo'
Weight (kg)	20,000	47,145	24,400	1400
Wheel diameter (mm)	900	950	–	700
Maximum speed (km/h)	–	70	60	70

(125 kW) with a hydro mechanic transmission. Their references were 2201 and 2202. They were dismantled in 1999 in Candás (Asturias).

In 1959, four new diesel railcars manufactured by Ferrostahl were used on the line. Their references were 2012, 2020, 2027 and 2028. The railcar number 2012 came from the Olot-Gerona line. It had two Büssing engines with six horizontal cylinders and hydraulic transmission. Its total power was 324 BHP (2381 kW). In 1968, it was transferred to the Ferrol-Gijón line, and in 1990, it was placed in Mallorca.

In 1962, a new railcar started to travel on the line. It was called “Almorox” and it came from the Tajuña line. It had two gas motors with a power of 505 BHP CV (382 kW) and a mechanical transmission. It was manufactured in 1933 by Carde and Escoriaza in Zaragoza under a German license from Eisenbahn Verkehersmittel A.G.

In 1963, two powered coaches and a conventional coach manufactured by Billard were introduced to the line. The powered coaches had reference numbers 2102 and 2144. The first one came from the “Secundarios de Castilla” line and the second from the Malaga-Fuengirola line. The powered coaches had reference number 5115. They had Willeme diesel engines with a power of 150 BHP (1103 kW) and a mechanical transmission (Table 3).

Until the introduction of diesel railcars, passenger coaches were used in combination with the different locomotives described above. When the line was opened, there were 30 passenger coaches, one of which was first class, six were second class, twenty were third class, two were mixed and twelve were used as baggage cars. In 1924, the number of passenger coaches increased up to 338. While there were 41 coaches in 1963, only 10 of them were still in service. With respect to the freight cars, there were 59 of them when the line was opened and 109 (only 97 of which were in service condition) in the last days of this line.

**Table 3** Name and technical characteristics of the different locomotives used on the Madrid–Almorox line

Number	Manufacturer	Config.	Ref.	Manufacture date	Locomotive name	Additional information
1	Krauss	0-6-0T	2296	1890	Madrid	Dismantle in 1964
2	Krauss	0-6-0T	2299	1890	Guadarrama	From 1953 is was used in Line from Fuencarral to Colmenar Viejo
3	Krauss	0-6-0T	2298	1890	Navalcarnero	Dismantle in 1964
4	Krauss	0-6-0T	2297	1890	Alberche	Dismantle in 1964
5	Krauss	0-6-0T	2300	1890	Villa del Prado	
9	Krauss	0-6-0T	5873	1908	Mentrida	Dismantle in 1964
10	Krauss	0-6-0T	6703	1912	Almorox	From 1953 is was used in line from Fuencarral to Colmenar Viejo
11	Couillet	0-4-4-4T	1076	1893	Zardo	Dismantle during Spanish Civil War (1936–1939)
11	Orenstein and Koppel		7683	1917		In 1917 it was given to Spanish Army, it was used in Cuatro Vientos
6	Krauss	0-6-0T			Alamin	From 1934 is was used in Fuengirola
7	Krauss	0-6-0T			Mostoles	From 1934 is was used in Fuengirola
8	Krauss	0-6-0T			Villamanta	From 1934 is was used in Fuengirola
	Couillet	0-6-0T	865	1887	Guipuzcoa	It became from line

## Bibliography

- “Anuario de la Industria Ferroviaria”. 1945–1946
- Aranguren J (1992) “Automotores españoles”. Editores Soto de Viñuelas Madrid: J. Aranguren D.L. 1992. ISBN 86-604-4753-7
- Arteaga FC (1999) “El ferrocarril de Almorox. El viaje a ninguna parte por tierras toledanas”, Studia Académica. Revista de Investigación Universitaria, nº8, pp 33–61
- Arteaga FC (2001) “Declive y emergencia del ferrocarril Madrid-Almorox. Un estudio de historia económica”. Universidad de Castilla – La Mancha. Revista Bibliográfica de Geografía y Ciencias Sociales. Universidad de Barcelona. ISSN 1138-9796. Nº282, 8 de Marzo de
- Búrdalo JJC (1998) “Compañía de explotación de los ferrocarriles de Madrid a Cáceres y Portugal y del Oeste de España”, Madrid, Fundación Empresa Pública
- Bustos CL (1952) “Aportaciones a la historia de los ferrocarriles españoles. Ferrocarriles secundarios y tranvías de la provincia de Madrid”. Ferrocarriles y Tranvías, pp 255–257
- Caballero DF (2009) “Desarrollo infructuoso de la infraestructura ferroviaria Madrid–Almorox” Congreso Iberoamericano de Ingeniería Mecánica
- Cambó y Batlle F (1918) “Elementos para el estudio del problema ferroviario en España” Madrid, Ministerio de Fomento
- Comín F, Martín P, Muñoz M, y Vidal J (1998) 150 años de historia de los ferrocarriles españoles. Fundación de los Ferrocarriles Españoles y Anaya, Madrid
- Consejo Superior de Transportes Terrestres (1966) “Estudio Económico de las Líneas Dependientes de ferrocarriles de Vía Estrecha”
- De la Torre E (1892–1935) “Anuarios de Ferrocarriles y Tranvías”
- Federación Castellano Manchega de amigos del Ferrocarril (1985) “Ferrocarril de Madrid-Goya a Almorox”. Líneas de Ferrocarriles en Castilla—La Mancha
- “Guías y Horarios de ferrocarriles” (1976) RENFE
- Melendo JA (2007) “La tracción en los ferrocarriles españoles”. Editorial Vía Libre, Madrid
- Memoria de la Compañía del Ferrocarril de Madrid a San Martín de Valdeiglesias (1887)
- Memoria de la Compañía Madrid a Cáceres y Portugal (1908)
- “Memorias de Explotación de EFE” (1941 – 1964) “Memorias de Explotación de FEVE” (1965–1970)
- Morley J, Spencer PG (1995) “Locomotives & railcars of the spanish narrow gauge public railways, Bridlington, Industrial railway society”
- Rivas EL (1993) “El ferrocarril Madrid-Cáceres-Portugal (M.C.P.) y su incidencia territorial”. Madrid, Universidad Complutense de Madrid
- Roca J (2007) “La cornisa Cantábrica en los años 70 y 80”. Revista Maquetrén. Nº170. Abril
- Tocino EA (2004) “F.C. de Buitrón a San Juan del Puerto”. Revista Maquetrén. Nº146. Abril de
- Vega MJ, Muriel FP (2002) “Los fracasos del ferrocarril madrileño: los casos del ferrocarril Madrid – Almorox y del ferrocarril del Tajuña”. Fundación de los Ferrocarriles Españoles
- Vieites G “El ferrocarril Madrid-Villa del Prado-Almorox”. Revista Trenmanía. Nº11 del año
- Yanci MPG (1994) “Los accesos ferroviarios a Madrid, su impacto en la geografía urbana de la ciudad”. CSIC. ISBN 84-7812-238-9



# Airship—The American Dream by Quirico Filopanti, 1851

Pier Gabriele Molari

**Abstract** The main purpose of the present paper is to answer the question, “Who invented the airship?” and to attribute the invention to Professor Quirico Filopanti (alias Giuseppe Barilli). The rediscovery of certain manuscripts and the link to two editions of an American newspaper dated January 1851 allow for this attribution. Filopanti wanted to make this machine to enable the migration of European people to the west coast of the U.S. in an inexpensive manner. The paper reports some biographic facts about the Inventor, including his willingness to be an engineer, and briefly lists his inventions, especially those of his period of banishment that have “re-emerged” out of the Archiginnasio manuscripts. After detailing Filopanti’s interest in balloons for studying atmosphere, some comments on his airship are reported. His brilliant idea that the future of flying was connected to the amount of power/weight that can possibly be put on board an aircraft is outlined. It is important to note the justness of this man, who believed in the power of the human mind. He had brilliant ideas on the necessity of enlarging the mechanical industry over the fashion industry and overcoming European fragmentation, envisioning a European Union, a very strange notion for those days.

## 1 The Rediscovered Manuscripts

Some manuscripts were recently rediscovered in the Archiginnasio Library of Bologna during a series of conferences devoted to Professor Quirico Filopanti<sup>1</sup> (Biblioteca dell’Archiginnasio di Bologna et al. 2013). The theoretical foundations for design of an airship, the machine named as such by him for the first time

---

P.G. Molari—Late professor of Machine Design in the University of Bologna.

---

<sup>1</sup>The name he preferred to be known by, disregarding his true name: Giuseppe Barilli.

---

P.G. Molari (✉)  
Machine Design in the University of Bologna, Via Vallescura, 23/3, 40136 Bologna, Italy  
e-mail: pg.molari@gmail.com

(Filopanti 2013), were found in these documents, so that the paternity of this machine can be attributed to Filopanti. He was a man of outstanding morality and completely devoted to the dignity of human beings. He was born in Budrio, near Bologna, in the year 1812, and died in Bologna in 1894 (Molari 2012; Anonymous 2014).

Filopanti put forward the idea of the airship design while he was in the USA in 1851, banished from Italy for political reasons. His writings were reported in the New York Daily Tribune on the 16th and 27th of January, 1851 (Filopanti 2013). This new idea was not developed any further due to the very high weight of the steam engines available at that time, which would have forced the machine to have very large overall dimensions. It was only in 1924 that navigation with an airship became possible, when Norge built the first actual machine. It may be noted that the dimensions of Filopanti's airship are similar to that of the famous machine by Zeppelin, operating between 1928 and 1937.

There are two manuscripts concerning the airship: a well-written copy and a draft. The former consists of a series of sheets numbered 1–31, of which number 8 is blank and numbers 18–28 are missing. The surviving chapters deal with: an introduction about the machine; the convenience of employing a buoyant system; the most proper form of an airship; the need for large overall dimensions; the moving power and the theory of the wings.

The other manuscript is essentially a draft of a conference speech reported by the New York Daily Tribune that also served as a draft for the Theory manuscript. These manuscripts are conserved at the Biblioteca dell'Archiginnasio in Bologna.

## 2 More on the Inventor

Quirico Filopanti, as written above, was born in Budrio in 1812. He took a degree in Mathematics/Philosophy at the University of Bologna in 1834 and was appointed a professor of Mechanics and Hydraulics in 1848 (Molari 2012). He was then banished for his political ideas to the U.S. and to Britain from 1849 to 1860; later, upon his return to Italy, he became a member of Parliament and a Professor, but refused the chair in solidarity with those colleagues who did not wish to swear fidelity to the King. In 1894, he died poor in a hospital room paid for by his friends.

He was always true to the spirit he had inside him, as shown in the question he posed to his students: *Do you not feel something inside of you which intends clearly and wants with freedom?*

So, his life sequence was: Propose—Arrange—Enact!

He lived in a very tumultuous period, for which reason some of his studies went missing and only very recently appeared in his manuscripts. Some of his studies, inventions, and engineering works (those known so far) are:

an instrument to measure the flow of rivers,  
a mechanical thermometer to be used in cow stables,

a cloth seal for hydraulic wheels,  
the “paltelata”: a simple dam for preventing the flooding of rivers (piles and hemp cloth),  
marine engines—hydraulics wheels working under the variable level of sea water,  
steam plowing,  
the drainage of the Pontine marshes (with General Garibaldi).

During his banishment, he studied, designed and occasionally applied for a patent for the following ideas:

a floating tunnel to connect England with France,  
an elastic power box to make it possible to have power on aerostats,  
iron balls used for warming,  
the air-ship.

He (Fig. 1) invented the idea of time-zones, as described in his book “MIRANDA!”, “A book of wonders hitherto unheeded” published in London in (Filopanti 1858).

He wrote about himself: *A man accustomed to always try to love the truth, how to express it without official exaggerations, and no official reticence.*

He wrote: *In the future, I will live with philosophy ... to take the world as it is! And to tell you the truth, strive to make it a little less foolish, or a little less sad.*

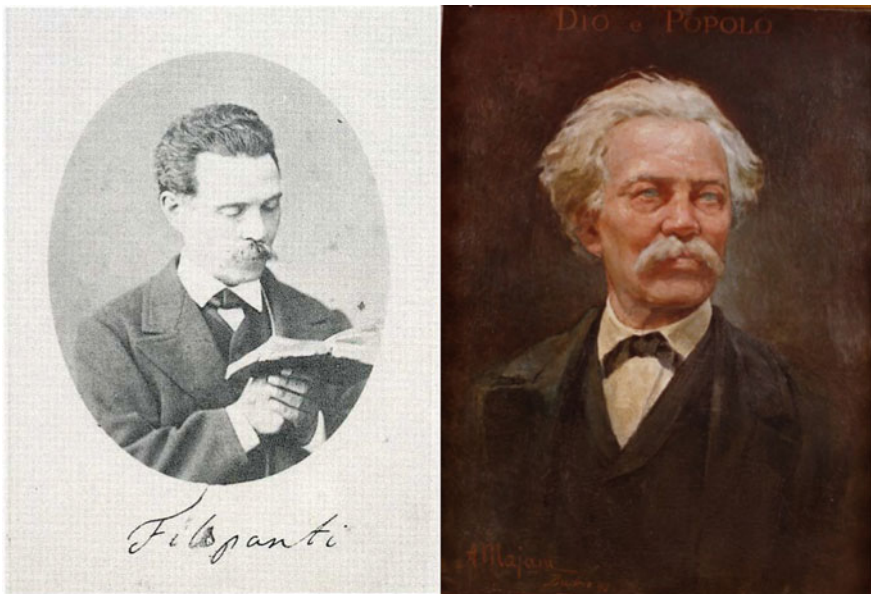


Fig. 1 Two portraits of Prof. Quirico Filopanti

On precursors, he writes:

It is all too easy to denigrate the men, and, more particularly, the revolutions that apparently failed. I say apparently, because, although they may have proven fatal for those who made them, provided they had a just purpose, they will be useful, more or less, to others. For starters, the failure is a tribute to the inexorable fortune demanded by souls in the subsequent success....

On inventions, he writes:

As nice and reasoned as an invention may be in its basic concept, the application will always stumble over a large number of practical difficulties, which then can ordinarily be overcome by dint of ingenuity and perseverance.

### 3 The Main Idea of the Air-Ship

Filopanti was particularly attracted to the idea of the composition of the atmosphere going all the way back to his first years in University. He asked the King for financial support to study how the physical properties of the air varied with the altitude and proposed that he himself conduct a trial with an instrumented balloon (Filopanti 1845a, b).

The separation between the buoyancy and the feed and the necessary oblong form to allow for directionality were the key innovations introduced in his machine. The large volume of hot air was especially necessary to support the massive weight of the steam engines to move huge wings. Filopanti's vision of the future of aeronautics appears clear, in spite of the confusion existing at that time, which tied the progress of aviation to the weight/power delivered by the engine.

His airship, due to difficulties in construction of its structure, was actually only realized seventy/eighty years later with the famous European airships which took the name of Norge Zeppelin. These airships were used for exploration of the North Pole and then discontinued after the disastrous fire that felled the Hindenburg Zeppelin during landing in New Jersey in 1937, even though the worst disaster happened, during landing as usual, to an airship built by the U.S. army.

### 4 The Description of the Air-Ship

From his own words, pronounced at the conference in Chicago, we can ascertain the main idea behind the airship design:

I will immediately have the honor of exposing to you, gentlemen, the solution and application that I myself have found. First, it is essential that the envelope which is to be filled either with hydrogen gas or with rarefied air be of a much larger capacity than ordinary

balloons. Then, it is equally essential not to make it of spherical shape, but considerably oblong. I propose a form composed of a cylinder of the length of seven of its diameters, and terminated by a hemisphere at each of its ends. The moving organ is to be a railroad locomotive, communicating its power, to four great wings, two of them above the cylinder, and two underneath. There, wings will not act as easy, moving alternately forward and backward, they must be composed of many windows turning on pivots a little above their middle: they shall be shut or upright when they go backward, and open, or in a horizontal position, when they go forward. As there will be a continual decrease of weight by the consumption of the fuel and water, the valve leaving issue to the gas must be kept continually open: the vesting degree of openness, however, will continually be governed by a proper instrument in such a manner as to keep the system at such precise elevation in the air as wanted, not greater or lesser. The direction must be obtained by a rudder, like in seagoing ships. The rudder man and pilot shall avail themselves, besides the ordinary compass, of a compass of amplitude, and occasionally, other nautical instruments. Proper places for ascending and landing shall be expressly chosen or made, as deagrer[?] and wharves for ships and steamers.

### **The Content of *the Theory of AIRSHIP—1851***

*By Q. Filopanti*

*Late Professor of Mechanics and  
Hydraulics in the University of Bologna*

*Introduction*

*I-Convenience of employing a buoyant system*

*II-The most proper form of airship*

*III-Necessity of large dimensions*

*IV-The moving power*

*V ... VI (missing)*

*VII-Theory of wings*

To give an idea of the content, it seems useful to report some sentences from Filopanti's manuscript to encourage the reader to seek out the original.

Filopanti, in the following, after sketching a brief historical review on the balloon acknowledging the Jesuit Wool, Horse, the Montgolfier brothers, the philosopher Charles, and the use of hydrogen by Pilatre de Rozier, puts forth a rhetorical question:

Are the currents of the atmosphere more terrible than the waves and the rocks of the ocean?

If the solution to the problem is possible, how is it that it has not yet been found out, after so many inquiries in so inventive an age?

and then he answers:

This problem is neither so easy as some men have flattered themselves that it was, nor so difficult as regarded by others.

The experiments must be made upon a gigantic scale, or they are of no service: therefore, even a man of genius, without the assistance of calculae, and of a large fortune will never succeed in the direction of aerostats.

## 5 Introduction

Filopanti says:

Unhappily, very few mathematicians apply themselves to anything other than abstract questions, generally of high intellectual beauty, but seldom of any immediate and living service to society at large.

The number is not very large of men who would be ready, without the least fear and doubt, to put their life and reputation at stake, to test practically whether twice two really makes four in actual fact, or only in the Pythagorical table.

He states the object of the treatise and declares himself unable to dispel the prejudices:

The object of this little treatise is to propose and explain a solution to the problem of atmospheric navigation, founded on mathematical calculation. I have faith in their correctness. Nevertheless, I shall make no special attempt towards any practical execution: not because I am in doubt that success would attend a trial properly made, but because I think I am unable personally to triumph over the torrent of prejudices existing even in the most enlightened countries against projects of aerial navigation. I may be permitted to say that, after all, men's minds are much more difficult to push in a desired direction than balloons themselves.

Filopanti gladly gives the credit to others. He writes:

... but to honor successful executors is just, as to execute is often much harder than to conceive.

On prejudices:

It is claimed that air cannot be navigated, because balloons run in a single medium, air, instead of two, air and water, like ships.

... [ships] have the advantage of being kept on a constant horizontal plane, without any effort on the part of the seamen: balloons, on the contrary, are liable continually to ascend or descend in the air;

The only logical consequence of this is that it is more difficult to navigate air than water: but to say it is impossible is a very different thing.

He compares the motion of birds and highlights the separation between the power they require to sustain themselves from that needed to move horizontally:

...extraordinary a power for moving their wings, they are obliged to employ the greatest part of it, not to run through the air, but to keep themselves up in it; as a flying bird keeps its body, your system would go to attack two great difficulties at once: help me in surmounting a single one of them first; perhaps I may be able, afterwards, to give you some feeble assistance to overcome the other as well.

Filopanti, looking at birds' muscles, says:

It is quite singular that such a statement of rational mechanics may be illustrated by a very vulgar culinary notion.

The idea of the airplane

I do not mean, however, that air navigation founded on the principle of the flight of birds is impossible.

I am so little inclined to say so, that I freely profess my opinion, that {as} long [as] we shall have machines of a much lighter bulk for a given power than we now have, then we shall be able to fly, properly speaking, through the air, at a far greater speed, safety, and economy than is to be expected even from any improved system of balloons.

The balloons should not be in the shape of birds or fish, because:

A greater error would be to give balloons the form either of birds or of fish, as many have suggested. It should be borne in mind that Nature, in fashioning the bodies of animals, had not simply their locomotive faculties in mind, but the particular wants of their living organization, and that balloons are by no means living bodies.

## 6 On The Most Proper Form of Airship (the Shape)

This resistance is generally independent of the length, and only proportional to the greatest transverse vertical section: consequently, to augment the volume, and by it the ascending power of the aerostat, without augmenting the resistance the air will oppose to it, it must have an oblong form.

I propose: a cylindroid body having its axis horizontal, and composed of a cylinder with two half globes, one at each end of the cylinder, the total length of the cylindroid being equal to eight of its diameters...

A cylindroid of our supposed form meets with a resistance to its progressive horizontal motion, in the air, nearly equal to that of a single common balloon having its own diameter, but is eleven times and a half larger than the latter: consequently, while the common balloon may be unable to support the moving apparatus necessary to propel it at a moderate speed, our cylindroid, having an ascending power more than eleven times greater, may be very well enabled to uphold both a greater number of men, and a greater store of moving power.

## 7 Necessity of Large Dimensions

Starting from “experimental” data, he referred to human musculature ...

The greatness of dimensions of the airship is not an accessory but an essential feature of this system. It may be demonstrated by calculation that a robust man working at his best advantage with {mass} could drive a spherical balloon of twenty four feet diameter (7,3 meters) at the rate of two miles an hour (3,6 km/h) in quiet air.

Then, as usual, he enjoys playing with numbers ...

To obtain a double velocity, still with a balloon of twenty four feet diameter, the power required would not simply be double, but one eight times greater. Another balloon four times greater..... to be driven at four miles an hour (7 km/h), would require the power of thirty two (32) men, though it could only lift eight (8) of them.

The least number of men capable of driving, by their muscular exertions, an airship of our cylindroidal form, at the rate of eleven miles an hour (20 km/h), would be 2078, its diameter should be 120 feet (36 m), and its length 960 (293 m).

To drive a spherical balloon at the same rate, it would take no less than the enormous number of two hundred thirty thousand men (230.000), and its diameter would be one thousand two hundred and seventy six (1270) feet (387 m);

It is true that a larger balloon requires a greater power to be driven at a given rate of speed; but this resistance, proportional to its surface, grows in the ratio of the square of the diameter, while its volume, and, with it, its ascensive power, grows in a greater ratio, that of the cube of the diameter. Therefore, by increasing its diameter more and more, we must finally reach a limit at which its ascensive power will be so great as to be able to support all the men or machinery capable of impelling it with the desired speed.

The starting statement:

...it may be possible to obtain the effect of the propulsion of airships by any kind of force already known and used ..... wind, water, animals, man, and steam, the two latter are the only ones worthy to be tried in common practice...

Filopanti uses experimental data to calibrate the power needed:

The weight of a dressed adult man may be reckoned, on the average, at a hundred and fifty *avoirdupois* (150) pounds (68 kg).

The walking power (playing *Borgnis's* piano) is capable of raising in ten hours two million pounds to the height of one foot (10 ore 2.000.000 = 907 kg 0,3048 m), or one pound to the height of two millions of feet (1p = 0,4536 kg a 2.000.000 feet = 610 m).

## 8 The Moving Power

Regarding the power of a steam engine, Filopanti writes:

According to the canon we have already demonstrated, that a mechanic effect of 300 000 pounds raised to one foot (136.080 kg, 0,3048 m) consumes six pounds (2,7 kg) of water and one of coal (0,4536 kg), she would require for a continual work of ten hours 22,400 pounds coal and 134,400 pounds water (10 h 10 ton of coil e 61 ton of water). To which add the proper weight of the engine, 28,000, it makes on the whole a weight of 184,000 pounds (83,5 ton).

Now, the 3400 men, whose power is equivalent to, weighing on the average 150 pounds each, and thus, no less than 510,000 pounds (231 ton) all together, a weight nearly treble than the one just now calculated, belonging to the engine and her total supply necessary to do all the work these men can perform in a whole day.

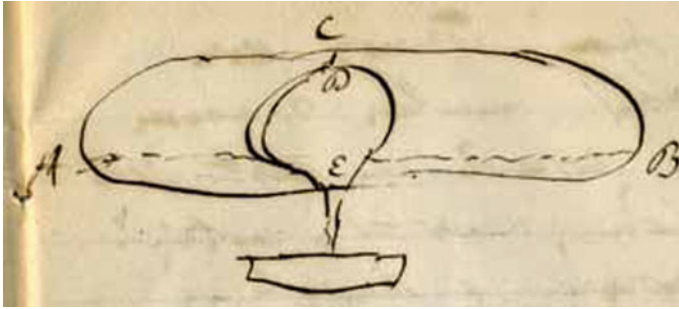
Filopanti concludes in regard to the moving power:

There is no doubt, therefore, that for our purpose, steam power is by far more economical than manpower, not only on account of the price, but also of the weight.

## 9 The Shape and Construction of the Wings

To this effect, let each one of the wings be divided into many rectangular windows by horizontal and vertical bars: to every window, a shutter (let us call it so) is to be applied, formed of a light frame and a canvas spread over it.





**Fig. 2** A sketch of the improved design of an airship by Filopanti taken from lecture notes from 1862, now in Biblioteca dell'Archiginnasio, Bologna (Italy)

To have this more conveniently done, the shutter must be inserted into the window in such a manner as to make the inferior sash of the shutter, when closed, to be juxtaposed abaft to the frame of the window, and the superior sash of the shutter to juxtapose itself to the frame of the window afore.<sup>2</sup>

The pressure or resistance of the air striking a plain surface perpendicularly is proportional to the area of the surface and to the square of the velocity.

The resistance of a spherical body, like the bow of our airship, to a wind of ten feet per minute has been proved to be nearly equal to an ounce per square foot of a transversal section or basis. Here also, the resistance, with different velocities, is proportional to the square of the velocity.

...the pressure on the bow of the airship, that is to say, the resistance of the air to her motion, is equal to the difference between the resistance of the wings moving backward and the resistance of the two wings returning forward.

So, we shall calculate the power of the engine, and the quantity of water and fuel to be taken in, at the rate of three times the effect we propose to ourselves to obtain. (safety coefficient = 3)

Supposing they are made to describe an arch from forty to sixty degrees, and go back with half the velocity of the air ship, the united surface of the four must be about equal to four times and a half the square of the diameter of the cylindroid.

A further development in his idea of the airship is reported in the manuscript of lessons he held at the University of Bologna in 1862. In this version, his oblong-shaped airship is partially filled with water to stabilize the machine and equipped with a balloon filled with steam derived from the steam machine (Fig. 2).

## 10 A Comparison with Other Air-Ships and a Jumbo

As reported in the American newspapers in 1851, Filopanti's air-ship was designed to carry 328 persons, was to have had an oblong shape of 292 m, a circular section with a diameter of 36 m, and was to have been filled with air heated to a temperature 170 °C higher with respect to that of the air outside. Filopanti calculates,

<sup>2</sup>We can notice in that a tribute to the remembrance of his carpenter father.

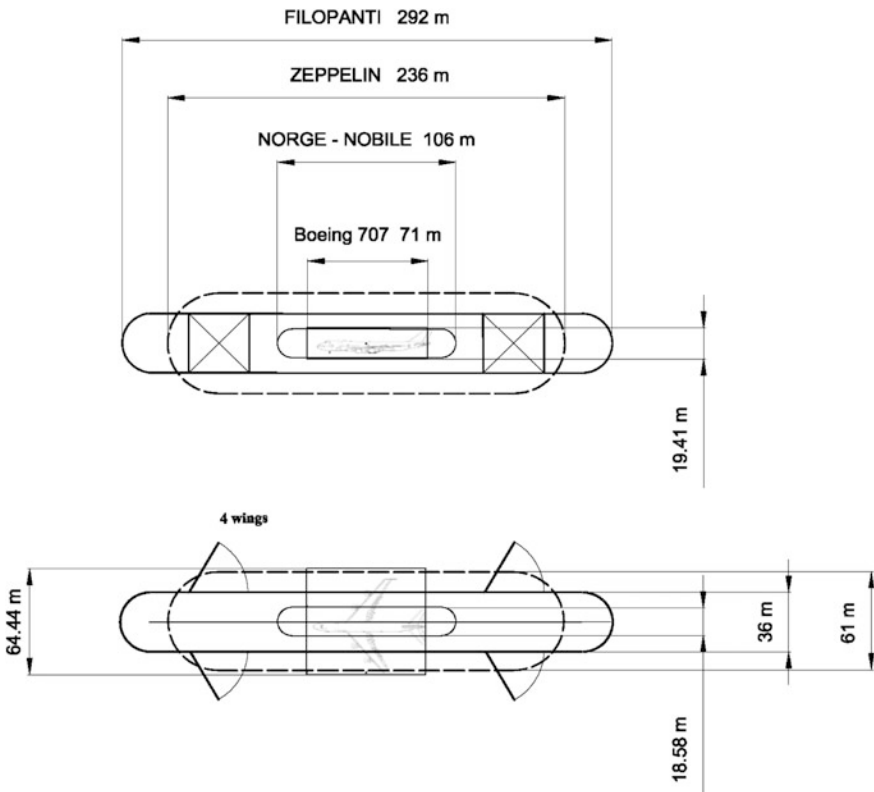
using a 179 KW (243 CV) steam engine, that the airship could reach a speed of about 18–20 km/h. The airship is driven by four wings with a total surface of about four and half the transversal dimension of the ship. Filopanti estimates the approximate cost at that time be less than \$20,000.

Figure 3 shows the shape of Filopanti’s air-ship compared to that of other airships and of the airplane Boeing 707. The principal dimensions and characteristics of these machines are:

*Nobile Norge Airship* (1924–1926)—length 106 m, 18.58 m diameter, volume 18,000 m<sup>3</sup>, payload 6425 ton—3 six cylinder in-line engines with 245 hp each Max speed 113 km/h, cruising 93 km/h;

*Zeppelin Airship* (1928–1937)—length 236.60 m, 30.50 m diameter, volume 105,000 mc, payload 30–60 ton—5 V 12-cylinder engines, each engine 530–550 hp, Max speed 110 km/h, range 10,000 km;

*Boeing 707 Jumbo* from 1969, length 70.66 m, wide 64.44 m height 19.41 m, weight 178,800 ton, passengers 524—4 turbo engines generate a force 4 × 282 kN, max speed 988 km/h, cruising 913 km/h, range 13,445 km.



**Fig. 3** A comparison between the dimensions of Filopanti’s airship and those of other flying machines: ISO views

## 11 Conclusions

Filopanti invented the airship. He was an engineer, as he writes in regard to his own profession, who thought big to satisfy his desire for innovation, which he identified with a constant search for the truth and therefore with closeness to God. He saw his constant mental exercise as a necessary contribution to alleviating the suffering of mankind. Looking at the spirit of this man, it does not seem out of place to compare his way of thinking to the Renaissance representation of ideas ascending to the sky toward God. The ascending balloon appears as a brilliant iconization of this concept. In the wood reliefs of Federico da Montefeltro's *Gubbio studiolo* (Raggio 1999), now at the Metropolitan Museum in New York, we can see a good example of this metaphor.

The author would like to thank Dr. Mirko Maraldi and Springer Reviewers for the revision of the text.

## References

- Biblioteca dell'Archiginnasio di Bologna, Mostra su Filopanti, a cura di Maurizio Avanzolini, Marilena Buscarini e Marcello Fini (2013). <http://badigit.comune.bologna.it/mostre/filopanti/index.html>
- Anonymous (2014), A recent update in Wikipedia with an extensive bibliography (in Italian). [http://it.wikipedia.org/wiki/Quirico\\_Filopanti](http://it.wikipedia.org/wiki/Quirico_Filopanti)
- Filopanti Q (1845a) Bartolini e la Cerrito ossia dell'onorare e premiare gli artisti, Tip. Delle Muse, Bologna
- Filopanti Q (1845b) Notizie di Fisica, Bologna, Tip. Delle Muse
- Filopanti Q (1858). In: James Morgan (ed) *Miranda! a book on WONDERS hitherto unheeded*, London
- Filopanti Q (2013) The theory of air-ship, a transcript of the original manuscript by Pier Gabriele Molari, Biblioteca dell'Archiginnasio. Bologna. <http://badigit.comune.bologna.it/mostre/filopanti/3%20-%20L%27esilio%20negli%20Stati%20Uniti/LibrettoAirShipFinale.pdf>
- Molari PG (2012) Quirico Filopanti professore di meccanica applicata e il corso di meccanica applicata da lui tenuto nell'universita' di bologna dal 1848 al 1850 e dal 1862 al 1864. doi:10.6092/unibo/amsacta/3246 <http://amsacta.unibo.it/3246/>
- Raggio O (1999) *The Gubbio Studiolo and its Conservation*, New York, The Metropolitan Museum

**Part IV**  
**Human Inventiveness for Mechanical  
and Scientific Devices**

# Archimedes' Screw in the Four Books “De Cochlea” by Guido Ubaldo del Monte [Santa Maria]—Venice—1615: The Engineering and the Language

Elena Magnini and Pier Gabriele Molari

**Abstract** The four books on the cochlea by Guido Ubaldo Del Monte (1545–1607) (Guidi Ubaldi e Marchionibus Montis in De Cochlea libri quattuor, 1615) are almost unknown to scholars who studied Archimedes' machine (Perhaps due to the fact that the author used the Latin language in the few copies that were printed and to the different ways in which the author's name has been spelled over time: *Guido Ubaldo*, *Guidubaldo*, *Guidobaldo*, *Monte*, *Dal Monte*, *Dal Monte Santa Maria*. Here, we adopt the name printed on the banner page of his book *Le Mechaniche*.) To give the deserved credit of the many improvements proposed by the author, a translation in Italian has been printed (Del Monte in Sulla Coclea Libri Quattro, 2013). In this paper, after dealing briefly with the initial history of the study of the machine, we will shed light on the changes introduced by Guido Ubaldo to Archimedes' screw and on the methodology he exposed. Even with the disadvantage of the book having been published after his death by his son Orazio, the logic in Guido Ubaldo's thought and the scientific method he introduced are clearly apparent, albeit, one can feel at times the discontinuity in the development of the logical sequence that the author would surely have avoided if possible. The writing style used in the four books is analyzed and some notes on the translation are given. A student's laboratory work on this machine is described at the end.

---

E. Magnini—professor of Latin Language at the Università Cattolica del Sacro Cuore;  
P.G. Molari—late professor of Machine Design at the University of Bologna.

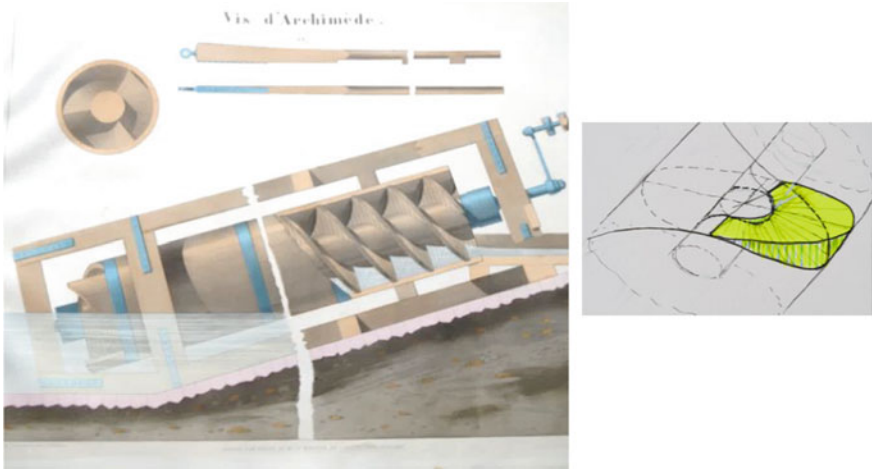
---

E. Magnini  
Università Cattolica del Sacro Cuore, via Govi, 23, 21100 Milano, VA, Italy  
e-mail: elena.magnini@alice.it

P.G. Molari (✉)  
University of Bologna, via Vallescura, 23/3, 40136 Bologna, Italy  
e-mail: pg.molari@gmail.com

## 1 A Short History on the Studies of the Machine

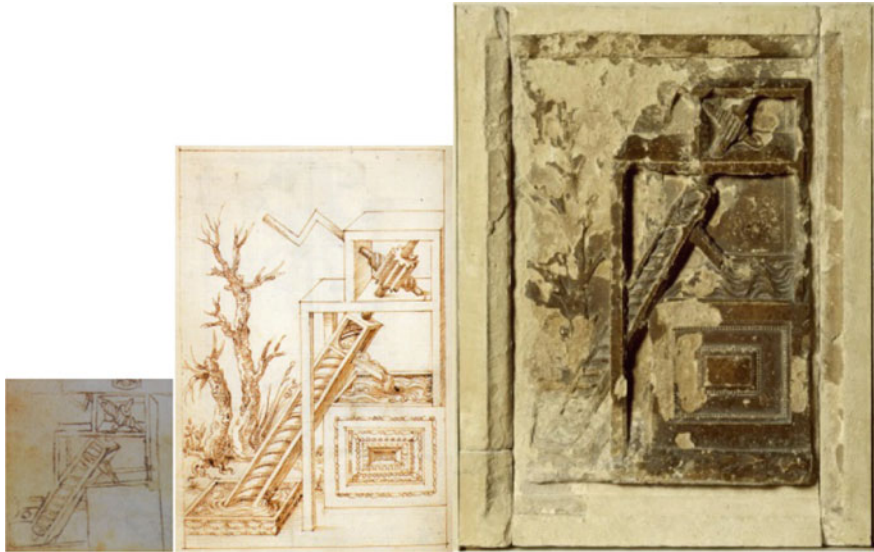
The cochlea, also known as Archimedes' screw pump (Fig. 1) (Morin, *Machine diverse, grave par E. Wormser, publie par ordre de le Ministre de l'instruction publique*), has been in use since ancient times (Fig. 2) up to the present day



**Fig. 1** A particularly fine drawing of a wood cochlea from the tables of machines by Morin (Ceredi) and a sketch of a “pocket” filled with water (with a different slope)



**Fig. 2** Pompei, House |11, 15, baluster of the first floor inv. 56310; Casa dell'Efebo, triclinium (Koetsier and Blauwendraat 2004; Martines and Molari 2014)



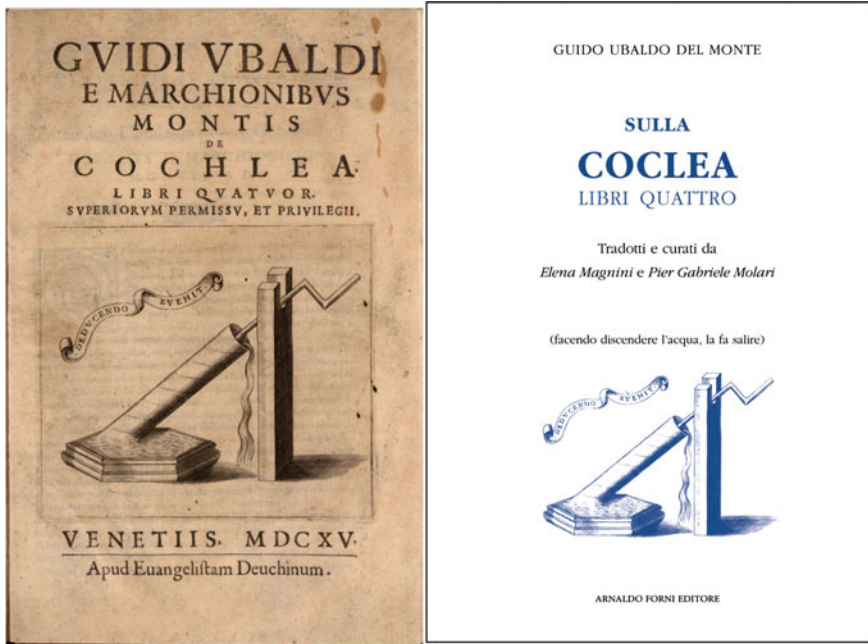
**Fig. 3** Archimedes' machine for raising water. From *left to right* a Francesco di Giorgio draft f.169r (di Giorgio 1989), a drawing on a manuscript now in Venice at Marciana f.25v ascribed to Francesco di Giorgio (Treviso:Permasteelisa Group 1999), the piece n.1 in the frieze of the Duke Palace in Urbino (Molari and Molari 2006)—note the unrealistic slope of the screw thread with respect to that of the machine

(Koetsier and Blauwendraat 2004; Martines and Molari 2014), wherever a large amount of water needs to be transferred against a limited hydraulic head (Rorres 2000; Müller and Senior 2009). During the Renaissance, especially after discovery of the technological-operative description in Vitruvius's book (Marcus Vitruvius Pollio, text), this machine was considered a gift from the human brain, as depicted in one of the *formelle* in the well-known Urbino frieze dedicated to the triumph of Engineering (Fig. 3) (Molari and Molari 2006; Pezzini 1985).

Due to the fact that its actual operating principle remained wrapped in mystery (“*quomodo descendendo sursum perveniat*” or “*deducendo evehit*”: rise due to falling), the curiosity of scientists has been continually excited over the centuries.

Among others, Galileo (Treviso: Permasteelisa Group 1999; *Le Mecaniche*) dealt with the problem. He gave an interpretation of the phenomenon mainly focusing on the motion of the water due to the rotation of the drum, and treated the geometry of the problem, very roughly speaking, essentially as a plane problem.

Guido Ubaldo discussed and understood the essence of the problem with a fair tridimensional model, but we had to wait for the work by Pitot (1736), Bernoulli (1738), Hennert (1766) and Belgrade (1767), appearing between 1738 and 1767, before a formal improvement in the study of the machine could be obtained. The machine has been fully modelled only recently (Rorres 2000; Müller and Senior 2009).



**Fig. 4** The book printed in Venice in 1615 and the vulgate (Guidi Ubaldi e Marchionibus Montis 1615; Del Monte 2013)

Guido Ubaldo’s book “De Cochlea”, written in Latin, still remains almost unknown, even though Galileo himself requested a copy of it directly from Guido Ubaldo. The authors of the present paper have, thus, decided to translate it into Italian, publishing a “vulgata” (Del Monte 2013) (Fig. 4), mostly for teaching purposes for a course on the history of mechanical engineering.

In this paper, the content of the four books is analyzed and the clever description of the active arch (*arc hydrophore* Pitot 1736; Bernoulli 1738) of the helix done by Guido Ubaldo is emphasized.

## 2 The Content of the Four Volumes

“De cochlea” is divided into four volumes, presented, after an introduction, as separate books. The first one deals with the geometry of helices. The second one deals with the volumes of water being separated inside the screw. The third book takes into account the flow of water, considering single “buckets” with an approximated geometrical method for the prediction of the active arc and of the force/power absorbed. The fourth one deals with multi-channel screws, and a new curve obtained by wrapping a circumference around a cylinder is formally described.



### 3 The Introduction

After two pages in which Orazio dedicates the book written by his father to Luigi Giustiniani, captain of the Venetian fleet, the goals Guido Ubaldo aims to reach are detailed. Some paragraphs discussing the typical writing style of that age follow.

As regards this cochlea, things are different: in fact, when we see water going upward due to the action of this machine, we are, indeed, surprised, because we imagine that this effect is produced by some sort of contrivance; and, as usually happens for this sort of thing, when we become aware of it, the wonder ceases and we remain little surprised; however, after knowing the actual reason for this kind of motion [of the water], not only does the wonder not cease, but it grows considerably, as we appreciate that, in this case, water is lifted up, whereas it usually falls; therefore, in this case, the cause producing the effect is worth the wonder, rather than the effect itself, whereas for other things, it is usually the effect that amazes rather than its cause. Indeed, all the causes of the mechanical effects do not fail to astonish, as we stated in our comments on the books written by those who aright admire Archimedes, but between this and other mechanical things, there stands a difference: in the other things, once the cause is known, the wonder does not cease, whereas in this case, the wonder increases, it grows, so that this thing seems extraordinary.

It's no wonder that, after people from both ancient times and the more recent past have written about this machine, we also dared to study it. I admit that they all have discussed this cochlea to a great extent, but they totally neglected certain important aspects regarding the perfect knowledge of this machine. In fact, they explain, or rather they just state (this is what we actually have understood from what we have read) that water is lifted up by this machine, but they do not explain how this is realized, so that, despite the fact that many papers on this cochlea can be found and [even though] this machine has been manufactured by men's own hands, it is not out of place to state that [the cochlea] has been left misunderstood over the centuries, as nobody has really shown themselves to have understood it properly and, moreover, nobody understood (as far as I am concerned) the contrivance that sits inside it: in fact, there is no chance of getting it by mere observation, if its cause is ignored....

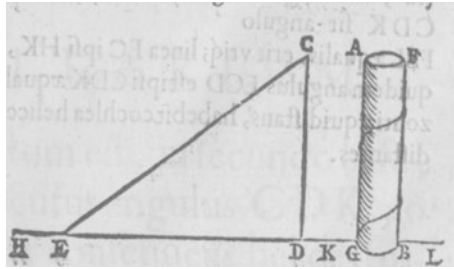
Where this effect comes from, that is, how it can happen that water is lifted up by the cochlea, is what we are going to explain to the best of our abilities, so that the exact cause of this effect can be understood: the research, to be fair, is an acute one and worth being known.

Hence, the necessity to build a model which takes into account the essential functioning of the machine, disregarding any secondary effects, and to ground it in a well-structured geometrical frame.

### 4 The Content of the First Book

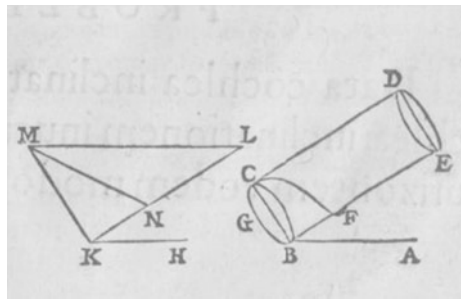
The first book deals with different geometrical demonstrations of the geometry of the helix and the length of the water trajectory in a slice of the rotating drum.

Guido Ubaldo treats the definition of the helix through the generating triangle (Fig. 5), then he considers the generating triangle at different positions of the cochlea. In the second proposition, he writes, "*Find the angular disposition of the*

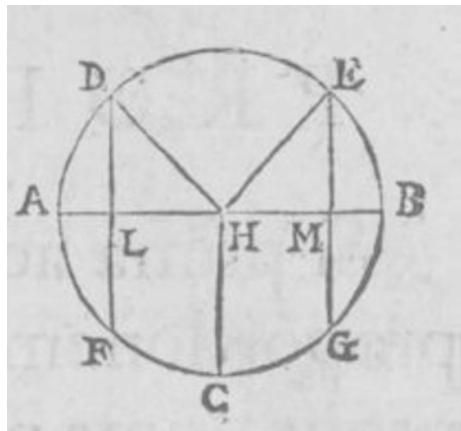


**Fig. 5** The generating triangle (Guidi Ubaldi e Marchionibus Montis 1615, f.5)

**Fig. 6** The requirements permitting the water to flow (Guidi Ubaldi e Marchionibus Montis 1615, f.9)

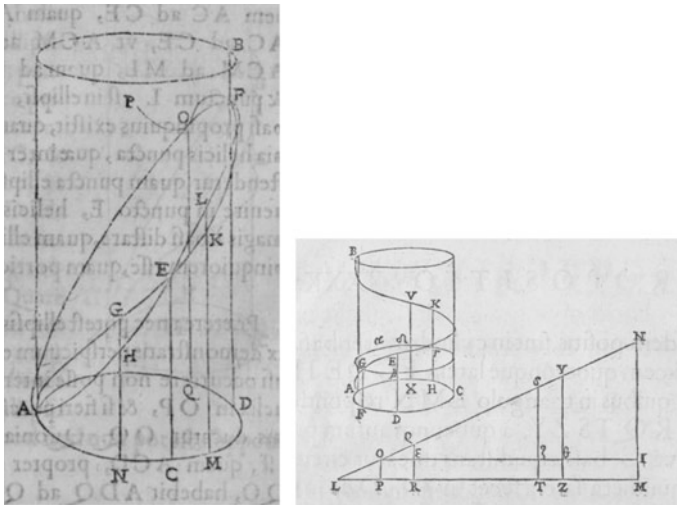


**Fig. 7** The figure has to be considered specular on the horizontal axis. The water is considered to stay in the generic arc ED due to the fact that the arc EB is greater than the line EM (Guidi Ubaldi e Marchionibus Montis 1615, f.14)



*cochlea so that the water can flow into the helix (can fill up the intake of the cochlea)” (Fig. 6).*

Then, a strange demonstration to explain why the water remains in the lower part of a sector of a circle (Fig. 7) is developed considering the length of an arc EB greater than the vertical segment ME, and arguing that the water stays in the lower part of the circle owing to the shorter distance it needs to travel.



**Fig. 8** Intersections between an *ellipsis* and a *helix* (Guidi Ubaldi e Marchionibus Montis 1615, f.51) and the way to use a parametric pointer referring to the basis of the wrapping *triangle* (Guidi Ubaldi e Marchionibus Montis 1615, f.42)

Guido Ubaldo considers the intersection of a cylinder with a plane and the intersection of a helix drawn on the cylinder with the resulting ellipse. The aim seems to refer to the intersections with the basis of the wrapping triangle, in order to use proportional segments to get the true positions of these points. We can, now, consider these efforts in a parametric way to describe these positions more easily (Fig. 8).

### 5 The Content of the Second Book

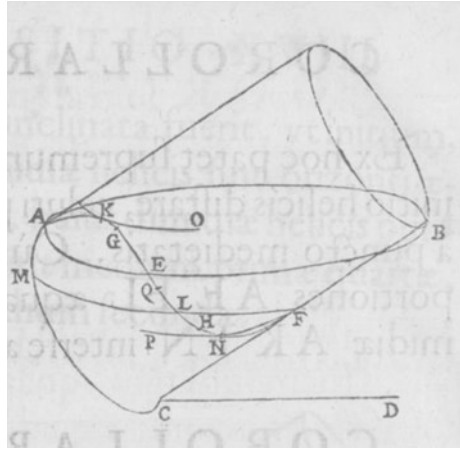
In this book, Guido Ubaldo uses the geometric assertions provided in the first book to evaluate the extension of the pocket in which the water ascends.

In Fig. 9, the point K is clearly shown as being the maximum vertical position of the helix. In the figure, a sequence of horizontal sections are drawn to determine the highest intersection with the helix in K and the lowest in N, hence identifying the pocket and all the points in between.

### 6 The Content of the Third Book

This book consists of a brilliant description of the physical behavior of the machine. Here, all the theorems on the intersections treated in the previous books are taken into account to construct the geometrical model of the machine. The machine is

**Fig. 9** The maximum and minimum points K and N in one turn of the *helix* (Guidi Ubaldi e Marchionibus Montis 1615, f.75)



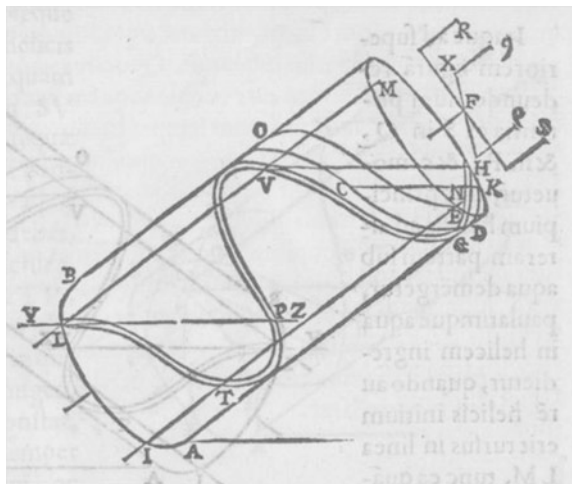
reduced to a small tube wrapped around the cylinder (Fig. 10). Then, the cross-section of the tube is reduced to a point. The helix obtained in this way allows us to measure the volume by means of a mono-dimensional curve looking only to the end points of the active arc of the pump LTP.

The trajectory of a small ball posed at T is clearly defined on the “latus” of the cylinder TE.

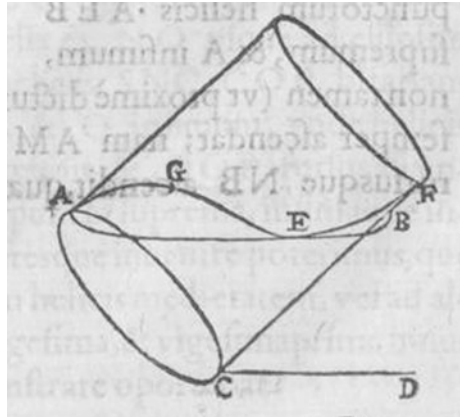
The relation between the maximum possible slope of the cochlea and the slope of the helix is clearly defined, as in Fig. 11.

The effort to describe this arc parametrically using proportions between segments did not result in success and that point appears to be the main reason why Guido Ubaldo did not publish the book during his lifetime. Nevertheless, he subdivides the segment into three, four, six and eight parts, avoiding showing the possibility of a

**Fig. 10** The cochlea reduced to a tube and then to a *helix* wrapped around the *cylinder*. The extension of the active arc LTP is clearly visible (Guidi Ubaldi e Marchionibus Montis 1615, f.118)



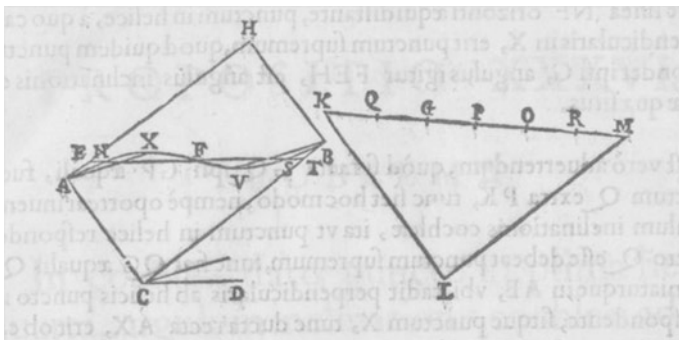
**Fig. 11** The maximum possible slope of the cochlea compared with the slope of the *helix* (Guidi Ubaldi e Marchionibus Montis 1615, f.91)



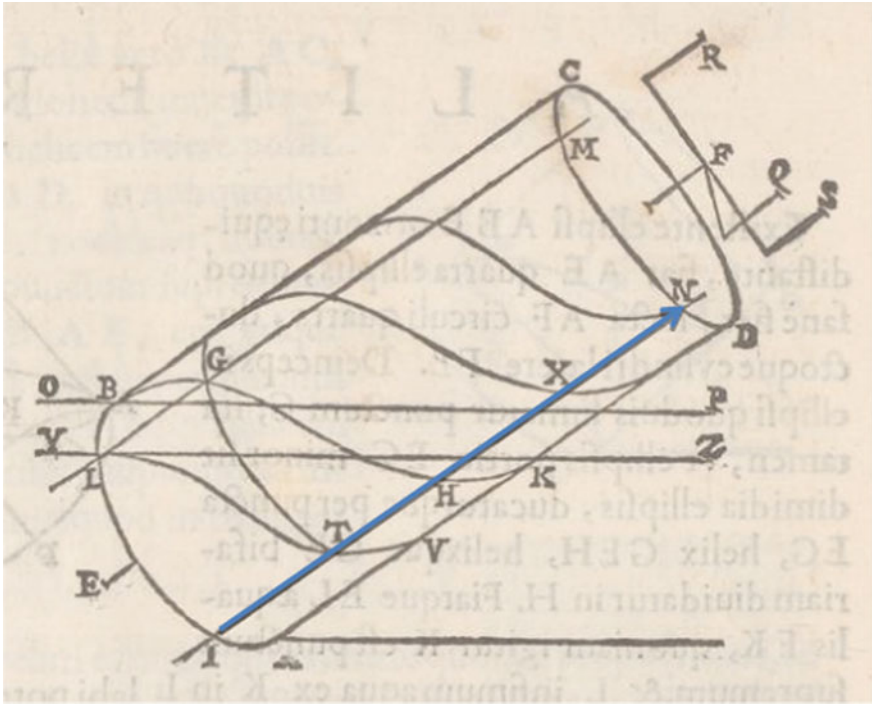
solution through numbers. He considered a numerical solution to be inconvenient, as he wrote in a letter concerning a book by Dr. Adriano Romano in Lovanio dated September 3, 1593 and sent to Galileo (Del Monte, letter to Galileo Galilei).

After having proven that a solution using proportions was not possible, Guido Ubaldo compared machines with different slopes and different lengths, considering also, in parallel, the power required to operate them. In that section, he uses the term “*possanza*” to represent both the force and the moment of the force and the power... this was not yet the right time to split these concepts, but nevertheless, he combined them within the idea of velocity and that of time, as it appears in the seventh, eighth and ninth sentences of the book.

The idea to consider the weights of the water pockets on the inclined plane with the aim of getting the required force on the driving crank was considered by Guido Ubaldo, but the results were far too inaccurate, since he based his estimation on the work by Pappus (Guidi Ubaldi e Marchionibus Montis 1581), which contained some misconceptions about the reaction of the ground (Fig. 12).



**Fig. 12** An approximate method to determine the length of the active arc (Guidi Ubaldi e Marchionibus Montis 1615, f.110)



**Fig. 13** The model of the pump (Guidi Ubaldi e Marchionibus Montis 1615, f.116)

The following sentences from this chapter will better explain these concepts.

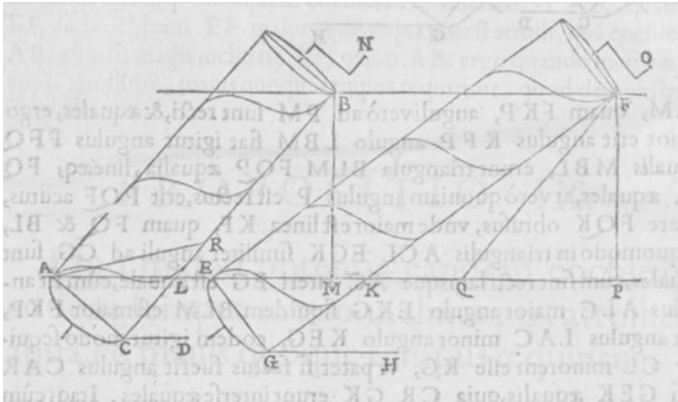
Only a small portion of the water will enter the helix, and it will certainly move from L to TV, but when the water arrives at T, it will stay there because of its nature, as T is the lowest locus; indeed, it will not move from T towards L, as it would move from a locus at a lower position to one at a higher position, which cannot occur. Knowing this, when the [shaft of the] cochlea is turned again, it appears clear that the volume [of water], during the revolution of the [shaft of the] cochlea, will always stay in the lower part of the helix.

... Then, water immediately moves towards the lowest position, located on the line IN, as along the helix LTV another one starts right next to it, and another one next to this, and so on, in such a way that water falling down along the helix will almost always stay along the line IN, and one has to imagine that in this manner it will move from H to X and from X to N. Then, as soon as the water, because of this motion, arrives at the top of the helix, it will flow out, as N is the lowest position, being along the line IN (Fig. 13).

In fact, referring to the same figures, consider the helix LTPV... drawn over the surface of a cylinder, as usual, having its own channel. As we stated, if the cochlea does not rotate, water remains in T, being the surface of the water along the line YLPZ, parallel to the horizontal, water will enter the helix until it fills up the entire volume LTP in the helix ...

But, as water has also another nature, so that it somewhat equilibrates itself until its surface is parallel to the horizontal, when it enters [the helix] in L and falls down to T, since more and more water enters, it will move until it gets to the surface YS at P and then it will remain there and no more water will enter and this amount of water in LTP, trapped there, will be the amount of water that the cochlea can take in this position. (Reference to Fig. 1.)

The same cochlea, the more it is inclined, the more water it will lift (Fig. 14).



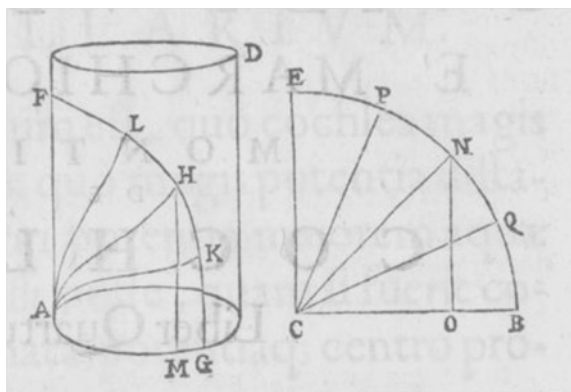
**Fig. 14** Cochleae of different slopes compared (Guidi Ubaldi e Marchionibus Montis 1615, f.132)

## 7 The Content of the Fourth Book

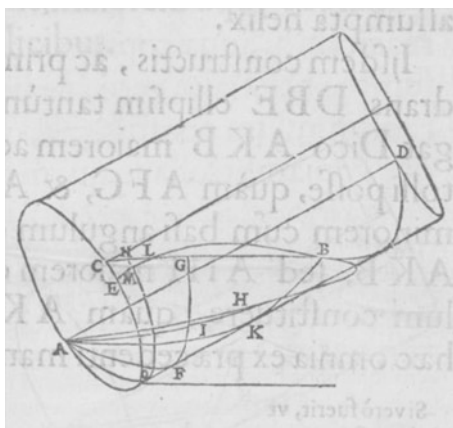
With the aim of finding the extreme points of the active arc, Guido Ubaldo discovered a new curve wrapping a circumference around a cylinder, as the end point of helices having the same length (Fig. 15).

Some properties of this new curve are considered. Guido Ubaldo tries to determine the maxima and minima of the helix taking the slope in the helix sheaf as a parameter, considering the circumference passing through them and referring the angle to the projection of the end point of its radius, as shown in Fig. 16.

**Fig. 15** A circumference wrapped around a *cylinder* and the relation between angles and segments as the basis (Guidi Ubaldi e Marchionibus Montis 1615, f.136)



**Fig. 16** A new parametric sheaf of helices to determine with proportions the position of the maximum and minimum of the active arc (Guidi Ubaldo e Marchionibus Montis 1615, f.157)



## 8 The Language Used by Guido Ubaldo

There is no doubt that Cicero is the style model for both Guido Ubaldo and his son Orazio.

Orazio, author of the dedication, gives it the form of a Ciceronian epistle, as acknowledged by the incipit: “Illustrissimo viro Aloysio Horatius e Marchionibus Montis s.d. [salutem dicit]”, and the conclusion, “Vale”.

Orazio then shows off his knowledge of the classic Latin period by presenting several typical constructions, all used with keen attention: from the prolepsis of the relative pronoun to the relative nexus positioned at the clause’s beginning; from the optative period to the final clause, introduced by “quo” rather than by “ut”, as it follows an adverb of comparative degree, to the hypothetical period and the direct and indirect interrogative clauses.

In both Orazio and Guido Ubaldo, we notice the same Ciceronian style previously found in the Humanists, who, refusing medieval Latin, went back to classic Latin, which they thought was more suitable for expressing their all-new line of thinking. Besides, Guido Ubaldo’s linguistic choices should not surprise us at all given that his text deals with a subject about which Vitruvius wrote long before him.

Orazio’s dedication, as well as the introduction to the work of his father, shows the same careful and consistent classic style; contrarily, the writing style in the scientific part of the work is heavier and more convoluted; in this part, for example, we find too frequent use of affirmative conjunctions and adverbs and causative clauses, perhaps introduced to make the writing less monotonous, presented in various ways, here by “quod”, there by “quia”, here by “quoniam”, there even by “quandoquidem” or “sidquidem”. Furthermore, the sections are, at times, extremely long and show redundant punctuation. A great number of commas and semicolons break up the speech where it would normally logically continue on.



On the other hand, the author respects the law of anteriority with great care; he is also very concerned with being as precise as possible when a line or a segment are indicated by an alphabetic letter alone, so he adds the definite adjective “ipse” where needed. Guido Ubaldo also makes use of some refined clauses: *quae quidem omnia invenire oportebat, quod facere oportebat, quod propositum fuerat, quod demonstrare oportebat.*

## 9 Other Authors of the Period

The work done by Guido Ubaldo can be compared to the approximation done by Galileo, and to a book in which the new contribution consists of cranks of exotic shape (Ceredi 1567).

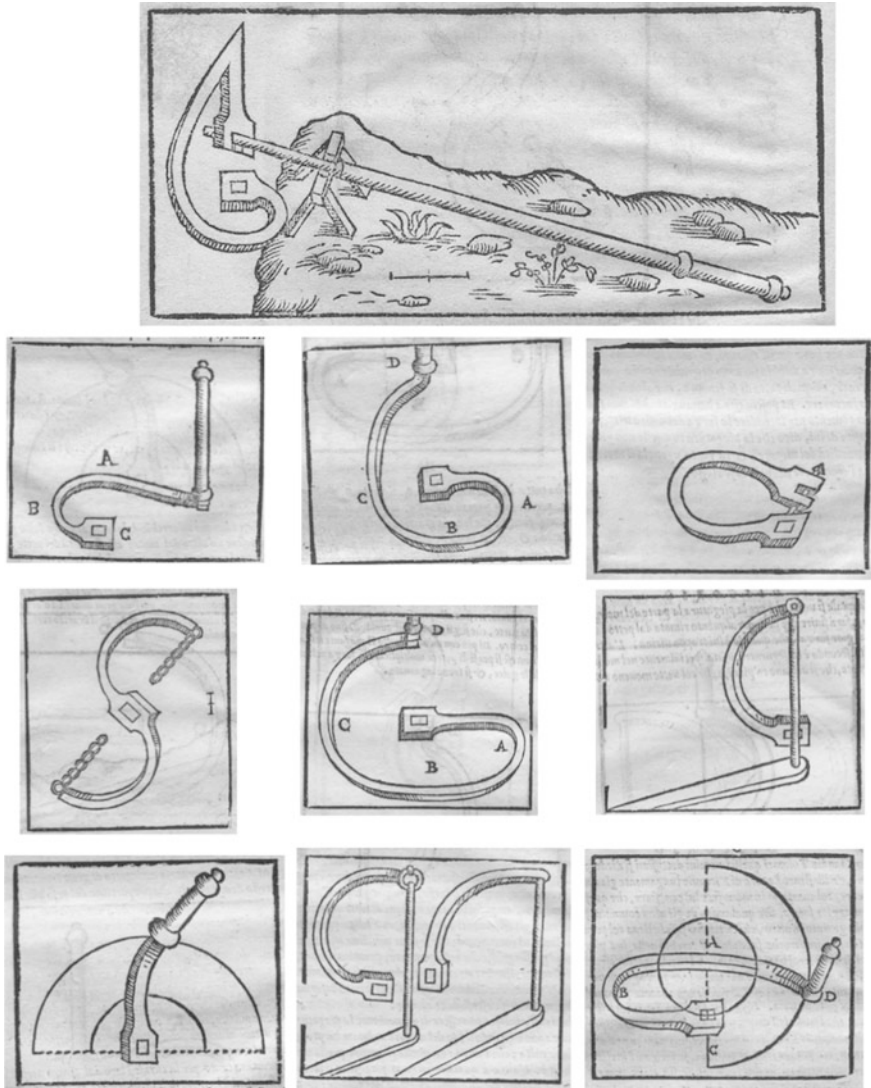
## 10 The Theory in 1700

As written above, we had to wait until the industrial revolution in France to get an improvement on Guido Ubaldo's studies. Pitot seems to have been the first to consider modelling the cochlea, as Guido Ubaldo did, as a helix and describing the inclined helix in an analytical way, using differential geometry to get the maximum and minimum points of the curve in space. He arrived at a solution of the differential equation by an approximated series. This approach was essentially geometrical, hence quasi static with respect to the motion. Later, the Academy of Belgium proposed an award to get a dynamic description of the flow inside the machine. Prof. Hennert, who was the winner, retraced the path followed by Pitot, adding some experiments on the dynamics of the machine, especially on those to be powered by a windmill. These were merely empirical formulas, such as the one to maintain the number of rotations per minute of the machine within 5 times the diameter of the machine.

## 11 The Working Models

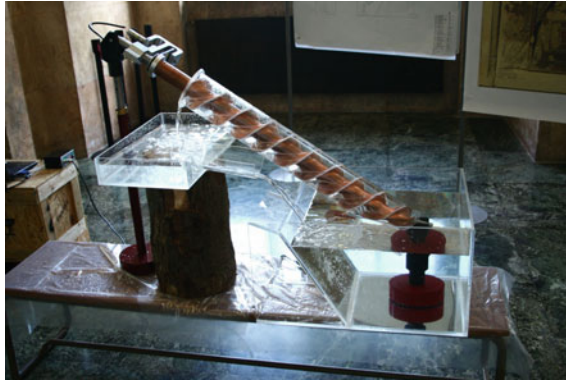
The students taking the laboratory course on the “History of mechanical engineering” at the University of Bologna decided to study the cochlea machine in depth, and after having understood its working principle, so well described by Guido Ubaldo, they redesigned the machine as described by Vitruvius, looking for a constructive solution based on the modulus concept (Guzzomi et al. 2012).

During a visit to the *Museo del Patrimonio Industriale* in Bologna, they were surprised to see that Prof. Francesco Masi (Ceccarelli 2005), former professor of Applied mechanics during the years 1891–1930, had built a machine that used the



**Fig. 17** An author of the same era, in order to improve the efficiency of the machine, was working on ... the shape of the crank (Ceredi 1567)

same principle they used to seal the screw and the drum, along with many constructive solutions similar to those they had employed. The model built by the students is now displayed at the Mateureka Museum of Mathematics, Pennabilli (Italy) (Figs. 17, 18 and 19).



**Fig. 18** The mock-up of Archimedes' screw designed and constructed by the students and displayed at the Faculty of Engineering of the University of Bologna in June 2013



**Fig. 19** The model by Prof. Francesco Masi (1890) (Ceredi [1567](#)), recently discovered and displayed at the *Museo del Patrimonio Industriale* in Bologna. The static seal between the screw and the external prismatic tube realized with 12 strips of glass was made using a leather square wire. This model was displayed and awarded in Paris at the Universal Exhibition in 1867 (Ceccarelli [2005](#))

## 12 Conclusions

The book on the cochlea by Guido Ubaldo Del Monte is a good example of the scientific level reached in Italian courts at the end of Renaissance (before Galileo Galilei) and seems particularly useful for teaching purposes in courses on the History of Science.

For this purpose, a translation into Italian, a short comment on the text and a brief note on students' work on this machine have been discussed.

**Acknowledgment** The authors would like to thank Dr. Mirko Maraldi and Springer Reviewers for the revision of the text.

## References

- Bellogrado J (1767) *Theoria Cochleae Archimedis*. Ed. Filippo Carmignani, Parma
- Bernoulli D (1738) *Hydrodinamica*. Henr. Deckeri, Basilea, pp sect IX, 183–199 tab. 52–53
- Catalogo Macchine Scuola Industria. Dal mestiere alla professionalità operaia (1980) Ed. Il mulino, Bologna
- Ceccarelli M (2005) Work and influence of Francesco Masi in Italy at the end of 19-th century. In: Proceedings of 3rd international workshop on history of machines and mechanisms, Moscow, 17–19 May 2005, pp 34–47
- Ceredi G (1567) Tre discorsi sopra il modo d'alzar acque da' luoghi bassi. Seth Viotti, Parma
- Del Monte GU (2013) *Sulla Coclea Libri Quattro*, Tradotti e curati da Elena Magnini e Pier Gabriele Molari, Arnaldo Forni Editore, Sala Bolognese. 978-88-271-3085-8
- Del Monte GU, letter to Galileo Galilei in *Opere di Galileo Galilei national Edition* in <http://www.liberliber.it>
- di Giorgio F (1989) *Codicetto, Das Skizzenbuch*. Biblioteca Vaticana, Urb. Lat 1757, Ed. facsimile Belser Verlag, Zurich
- Galileo G, *Le Meccaniche, Opere* Ed. Nazionale a cura di A. Favaro, II v., pp 148–190, Ed. Barbèra, Firenze, in (<http://www.liberliber.it>)
- Guidi Ubaldi e Marchionibus Montis (1615) *De Cochlea libri quattuor*, Venetiis. Deuchino Ed. <http://www.e-rara.ch> and in <http://mathematica.sns.it/opere>
- Guidi Ubaldi e Marchionibus Montis (1581) *Le Meccaniche*, Venetiis, Francesco de' Franceschi Ed; in <http://www.e-rara.ch>; Reprint Guido Ubaldo Del Monte, *Le Meccaniche*, a cura di P.G. Molari, Forni Ed, Sala Bolognese (Bo), 2013. ISBN 978-88-271-3086-5
- Guzzoni AL, Maraldi M, Molari PG (2012) A historical review of the modulus concept and its relevance to mechanical engineering design today. *Mech Mach Theory* 50:1–14
- Hennert JF (1766) *Dissertation sur la vis d'Archimede - qui a remporté le prix de mathématique adjugé par l'Académie Royale des Sciences et Belles-Lettres de Prusse en MDCCLXVI [S.I.]*, (ca. 1766) ETH-Bibliothek Zürich Signatur: Rar 5825 Persistenter Link: <http://dx.doi.org/10.3931/e-rara-10480>
- Koetsier T, Blauwendraat H (2004) The Archimedean Screw-pump: a note on its invention and the development of the theory. *International symposium on history of machines and mechanisms*, pp 181–194
- Marcus Vitruvius Pollio, text, [http://penelope.uchicago.edu/Thayer/E/Roman/Texts/Vitruvius/10\\*.html](http://penelope.uchicago.edu/Thayer/E/Roman/Texts/Vitruvius/10*.html)
- Martines G, Molari PG (2014) Un'altra macchina per sollevare l'acqua: la macchina dei Romani per la pioggia? V Convegno di Storia dell'ingegneria, Napoli 1:321–327
- Molari L, Molari PG (2006) *Il trionfo dell'Ingegneria nel fregio del palazzo ducale di Urbino*, Ed. ETS, Pisa
- Morin A, *Machine diverse, grave par E. Wormser, publie par ordre de le Ministre de l'instruction publique*. - Paris: Hachette, [18–?]. – 30 color tables 50 × 65 cm
- Müller G, Senior J (2009) Simplified theory of Archimedean screws. *J Hydraul Res* 47(5):666–669
- Organa *Mechanica Commento al Facsimile*, (Treviso:Permasteelisa Group, 1999), a-VINCENZO FONTANA, *Il teatro delle macchine di Guidobaldo Del Monte*, b-

- SUSY MARCON, Il codice Marciano Lat. VIII, 87 (=3048) caratteri materiali e antichi possessori
- Pezzini GB (1985) Il fregio dell'arte della Guerra nel palazzo ducale di Urbino. Istituto Poligrafico e zecca dello stato, Roma
- Pitot M (1736) Sur la vis d'Archimede, Histoire de l'Academie royale des sciences, annee 1736, Paris, 1739, pp 110–114 tab. Theorie de la vis d'archimede avec le calcul de l'effet de cette Machine, pp 173–183
- Rorres C (2000) The turn of the screw: optimal design of an Archimedes screw. J Hydraul Eng 126 (1):72–80

# On the Birth and Growth of Pendulum Clocks in the Early Modern Era

Francesco Sorge, Marco Cammalleri and Giuseppe Genchi

**Abstract** Measuring the passage of time has intrigued humankind throughout the centuries. Ancient times witnessed the appearance and development of clepsydras and water clocks, whose place was subsequently taken by mechanical clocks in the Middle Ages. It is really surprising how the general architecture of mechanical clocks has remained almost unchanged in practice up to the present time. Yet the foremost mechanical developments in clock-making date from the 17th century, when the discovery of the laws of pendular isochronism by Galilei and Huygens permitted a higher degree of accuracy in the measuring of time.

## 1 The Art of Clock-Making Throughout the Centuries

### 1.1 *Ancient Times: The Egyptian, Greek and Roman Ages*

The first elements of temporal and spatial cognition among primitive societies were associated with the course of natural events. In practice, the starry heaven played the role of mankind's first huge clock. According to the philosopher Macrobius (4th century), even the Latin term *hora* derives, through the Greek word *ώρα*, from an Egyptian hieroglyph pronounced *Heru* or *Horu*, which was Latinized into Horus and was the name of the Egyptian deity of the sun and the sky, the son of Osiris who was often represented as a hawk, the prince of the sky (Fig. 1).

Later on, the measure of time began to assume a rudimentary technical connotation and to benefit from the use of more or less ingenious devices. Various

---

F. Sorge (✉) · M. Cammalleri · G. Genchi  
DICGIM, University of Palermo, Palermo, Italy  
e-mail: francesco.sorge@unipa.it

M. Cammalleri  
e-mail: marco.cammalleri@unipa.it

G. Genchi  
e-mail: giuseppe.genchi@unipa.it

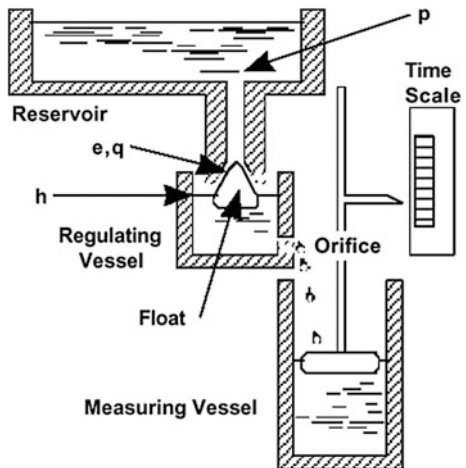
**Fig. 1** The Egyptian deity Horu



kinds of clocks were developed with relatively high levels of accuracy by the Egyptian, Assyrian, Greek and Roman civilizations.

Starting from the well-known water clock of Ktesibios (Fig. 2), for which the flow rate into the measuring vessel was constant due to the constancy of the level  $h$ , an incredible degree of precision had been reached in Rome during the late imperial age with clepsydras (whose etymology is linked to the Greek words  $\kappa\lambda\acute{\epsilon}\pi\tau\epsilon\iota\nu$  +  $\acute{\upsilon}\delta\omega\rho$  = steal + water), clepsamias (from  $\kappa\lambda\acute{\epsilon}\pi\tau\epsilon\iota\nu$  +  $\acute{\omicron}\mu\mu\omicron\varsigma$  = steal + sand), sundials or

**Fig. 2** Ktesibios' water clock (Alexandria, 3rd century BC)



sciateras (from  $\sigmaκιή + θεωρεῖν = \text{shade} + \text{observe}$ ), and astrolabes (from the Latin words  $astrum + labi = \text{star} + \text{slide}$ ).

Clepsydras were largely used in antiquity to measure short lapses of time, e.g., the peroration time in the courts of law. The Greek orator Lysias frequently suspended his speeches with the request, “ $\kappaαί \muοι \text{ἐπίλαβε το \text{ὔδωρ}}$ ” (“Please, stop the water for me”), so as to let his witnesses testify in front of the judges with no time constraint from the clepsydra (e.g., see speech *Against Panleon*).

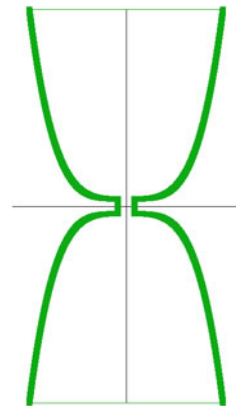
### 1.2 The Middle Ages

Some centuries later, the ancient clepsydras evolved into new types of water clocks and partly mechanical clepsydras, such as the little “alarm clocks” that were used in some monasteries of the Middle Ages consisting of a container that, once filled with water, let fall a metallic ball whose din awakened the provost.

It is not out of place to observe here that a constant speed for lowering of the water level can be theoretically obtained by a fourth degree parabolic shape of the meridian section of the container. In fact, the discharge velocity is proportional to the square root of the water level, while the flow rate is proportional to the product of the square of the container radius by the speed at which the level is lowered. Therefore, in order to obtain a constant lowering speed, the level must be proportional to the fourth power of the radius (see Fig. 3) and this shape seems to have been heuristically sought for some clepsydras of those days.

The first mechanical clocks appeared in the Byzantine and Islamic worlds, for both fixed and portable use, and in the subsequent early centuries of the Middle Ages, various types of weight clocks were owned by several notables and were generally equipped with a verge-and-foliot escapement (Fig. 4). At the same time, widespread construction of mechanical clocks of various sizes emerged, from big tower clocks to small pocket watches (Nuremberg eggs).

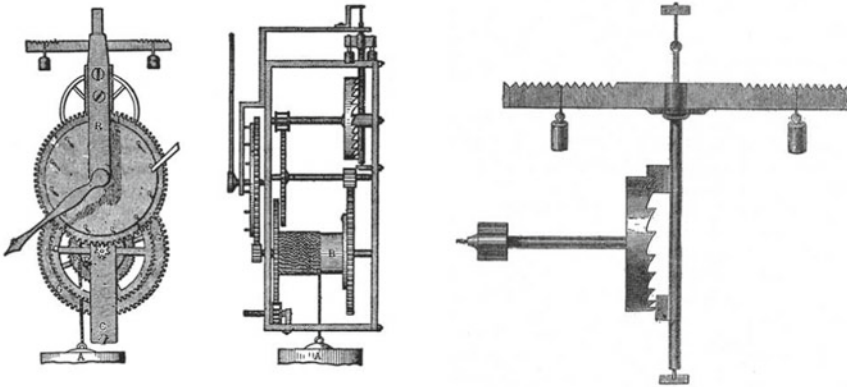
**Fig. 3** Fourth degree parabolic shape of meridian section







The presence of the verge-and-foliot mechanism in Old St Paul's, London, is documented in 1285

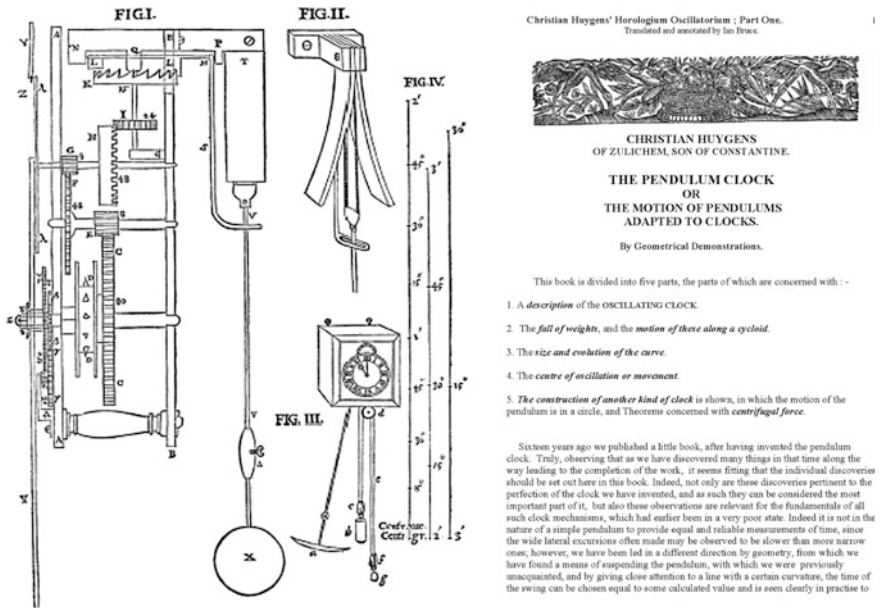


**Fig. 4** Verge-and-foliot escapement. From “*Encyclopédie, ou Dictionnaire Raisonné des Sciences, des Arts et des Métiers*”, edited by Denis Diderot and Jean le Rond d’Alembert in Paris, 1751–1772. The presence of the verge-and-foliot mechanism in Old St Paul’s, London, is documented in 1285

In the medieval period, the start of the hour count was different in respective European countries, though always with the same daily division of 24 h. Italy and Bohemia adopted the “*hora italica*” and “*hora bohemica*”, both from one sunset to the next, France used the “*hora gallica*”, from midnight to midnight, and British countries used the “*hora britannica*”, from one sunrise to the next.

This period saw modern clock mechanisms assume their structure gradually, a structure that has somehow been present in all successive clocks, right up to the present day, though with a great number of refinements and improvements. The so-called “main” mechanism comprises the driving motor, the gear transmission and the dial plate with the hands, while the “secondary” mechanisms include: the charging system, which restores the potential energy; the distribution system or escapement, which transforms the uniform motion generated by the motor into a periodic series of small progressive movements; and the regulation mechanism, the task of which is to ensure a constant oscillation period.

The foliot regulation system dates from before 1285 AD, in which year we learn about the presence of this type of device in Old St. Paul’s in London (Fig. 4). The foliot, the etymon of which is probably linked to the old French verb *folier* (to play or dance foolishly), was a horizontal balance bar carrying two weights, which



**Fig. 5** Verge and pallet escapement of Huygens’ pendulum clock. On the *right*: title page of Huygens’ treatise “*Horologium Oscillatorium sive de motu pendulorum*”, 1673, translated by Ian Bruce

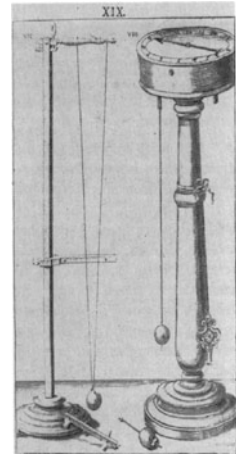
oscillated and interacted with a crown wheel through two pallets out of phase (Fig. 4). As no restoring force was acting on the system, the periodicity was referred to the foliot’s inertia, so that the time measurement was highly inaccurate (Diderot and d’Alembert 1751–1772) .

A successive adjustment of the foliot, at the beginning of the 16th century, consisted of the replacement of the balance weights with two elastic steel ribbons, thanks to Peter Henlein, who was a locksmith in Nuremberg. Nevertheless, the definitive evolution of the verge-and-foliot escapement associated the verge and pallet system with pendular regulation and permitted a fairly satisfactory precision, using, in particular, the cycloidal pendulum of Huygens’ clock (Fig. 5).

### 1.3 From Galilei’s Pendulum to the Modern Mechanical Clock Regulation

The laws of the pendulum were first studied by Galileo Galilei at the end of the 16th century and after that by Christiaan Huygens in the 17th century. There is an age-old diatribe about the precedence of Galilei or Huygens in realizing the first pendulum clock. According to legend, Galilei began to reflect upon pendulum motion in 1581, after observing the oscillations of a lamp suspended inside the

**Fig. 6** Pendulums used by the *Accademia del Cimento* to measure oscillatory phenomena. The one on the left might be identified with Galilei's *pulsilogium*. From “*Saggi di naturali esperienze fatte nell'Accademia del Cimento*”, Florence, 1667



Cathedral of Pisa. He had the ingenious intuition that the oscillation period was somehow independent of the amplitude and conceived the functional dependence of the pendular period on the suspension length and the suspended weight.

The pendulum could be used as a tool to measure time intervals and, for example, could find an application in medicine in measuring pulse rate. Galilei had the idea of a “*pulsilogium*” in the last decade of 1500 (Fig. 6) and discussed it in Padua with his colleague Santorio, who described this medical device in two books of 1620 and 1622. The pendulum length was adjusted each time to synchronize the pulse frequency, thus permitting its calculation.

Many years later, in 1641, Galilei proposed the use of the pendulum as a regulatory mechanism for clocks and outlined the related design. However, he was now old and blind and did not accomplish that project. As a matter of fact, it is to be remarked that the ideal pendular motion is strictly isochronous only if the amplitude of its oscillations is very small, as was specified by Huygens a few decades after the first Galilean studies. Actually, the first pendulum clock was built in 1657 by Huygens, who also conceived the brilliant idea of the cycloidal trajectory, which ensures the theoretical isochronism even for large oscillation amplitudes (Huygens 1673).

A copy of the original design of Galilei's pendulum clock, which had been traced in those days by Vincenzo Viviani and Vincenzo Galilei, student and son of Galilei, respectively, is available to visitors of the Museum of Galilei in Florence (Fig. 7) and represents the device illustrated by their master in his letter of June 1637 to the Dutch admiral Laurens Reael in order to compete for a prize of 30,000 guildens. In this letter, he described his method for detecting the longitude offshore with the help of the so-called “*Jovilabe*”, by comparing the local time with the hiding periods of Jupiter's Medicean satellites, Io, Europa, Ganymedes and Callisto. This comparison depended on the possibility of making an exact measurement of time, and to this end, Galilei proposed the idea for his own pendulum clock. Furthermore, Viviani also left a report on the process that led to the discovery of the pendulum laws and their possible application.

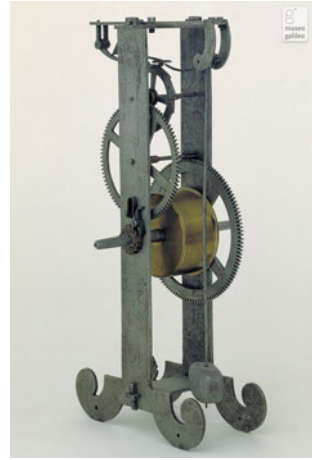


**Fig. 7** Copy of the design of Galilei's clock mechanism by Vincenzo Viviani and Vincenzo Galilei. Copyright of *Museo Galileo*, photographic archives, Florence

Figure 8 shows a reconstruction of the pendulum clock with the Galilei escapement, which was realized in 1879 by the Florentine clock-maker Eustachio Porcellotti on the basis of Viviani's design and is preserved in the Museum of Galilei as well.

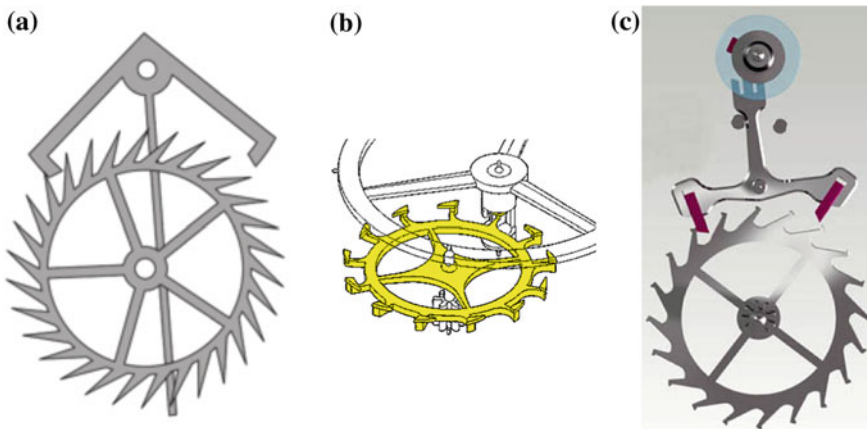
In spite of such previous studies by Galilei, the invention of the pendulum clock was claimed in 1658 by Huygens, whose primacy was hotly contested by Viviani.

**Fig. 8** Reconstruction of Galilei's pendulum clock by Eustachio Porcellotti (1879). Copyright of *Museo Galileo*, photographic archives, Florence



It is reported that, observing Viviani's designs, Huygens sharply declared: "It cannot work!"

Regulation by the balance-wheel-coil-spring system was later introduced by Hooke in the late 17th century, and in the meantime, the escapement evolved from the verge to the anchor, which was introduced by Clement in 1670, and then to the escapements of the deadbeat, cylinder and lever types, which were realized by Graham, Tompion and Mudge, respectively, in the 18th century, reaching a higher precision due to the elimination of any recoil movement (Fig. 9). Later on, the clock structure and the working technique would basically remain nearly unaltered throughout the modern and contemporary ages, until the recent appearance of electric clocks, which, however, did not cause the disappearance of mechanical clocks (Heidrick 2002).



**Fig. 9** Escapement of later centuries: **a** deadbeat escapement of Graham; **b** cylinder escapement of Tompion; **c** lever escapement of Mudge (Audemars Piguet)

## 2 Pendular Motion

### 2.1 The Pendulum Isochronism

Galilei described the pendular mechanism for clocks in great detail in 1641, but he did not accomplish that project owing to the infirmity of his age. Taking up a point discussed above, the ideal motion of the simple pendulum tends to become isochronous only if the amplitude of its oscillations is very small. When Huygens based his 1657 pendulum clock on the brilliant idea of cycloidal trajectory, the isochronism derived from the tautochronous property of the cycloid.

The study of the cycloid started with Galilei and continued with Fermat, Huygens, Newton and Bernoulli. Some relevant properties are:

- Indicating the radius of the generating circle with  $r$ , the evolute and the involute of a cycloid are two other identical cycloids, shifted a distance  $2r$ , upward and downward in the direction orthogonal to the base and a distance  $r\pi$  in the direction parallel to it.
- The cycloid is tautochronous (*ταυτός χρόνος* = same time): a point mass always slides down to the bottom in the same lapse of time regardless of the starting position.
- The cycloid is brachistochronous (*βράχιστος χρόνος* = shortest time): the path that ensures the shortest sliding time from an upper fixed point to a lower one is an arc of cycloid, as may be proved by a variational approach using the Euler-Lagrange equation.

Observing Fig. 10 and using the notation reported there, since  $ds_p = 2r \cos(\varphi/2) d\varphi$  according to the kinematical laws of rigid motion, the arc of cycloid measured

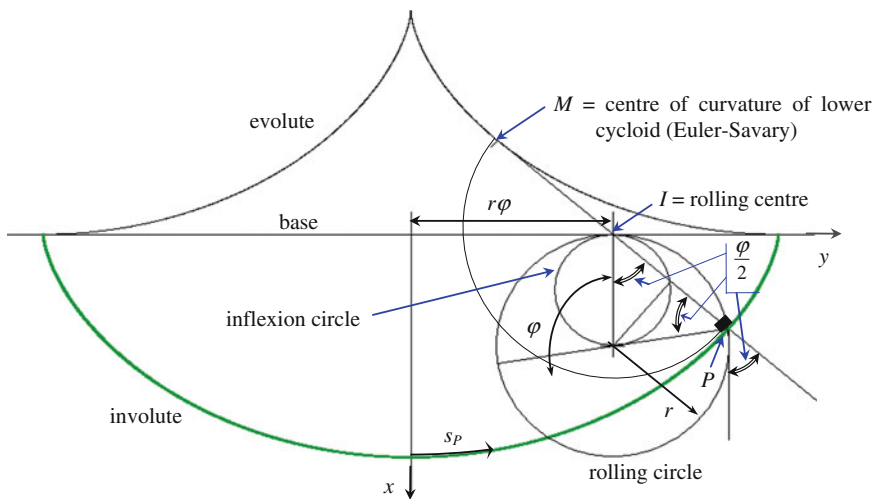


Fig. 10 Cycloid tautochronism

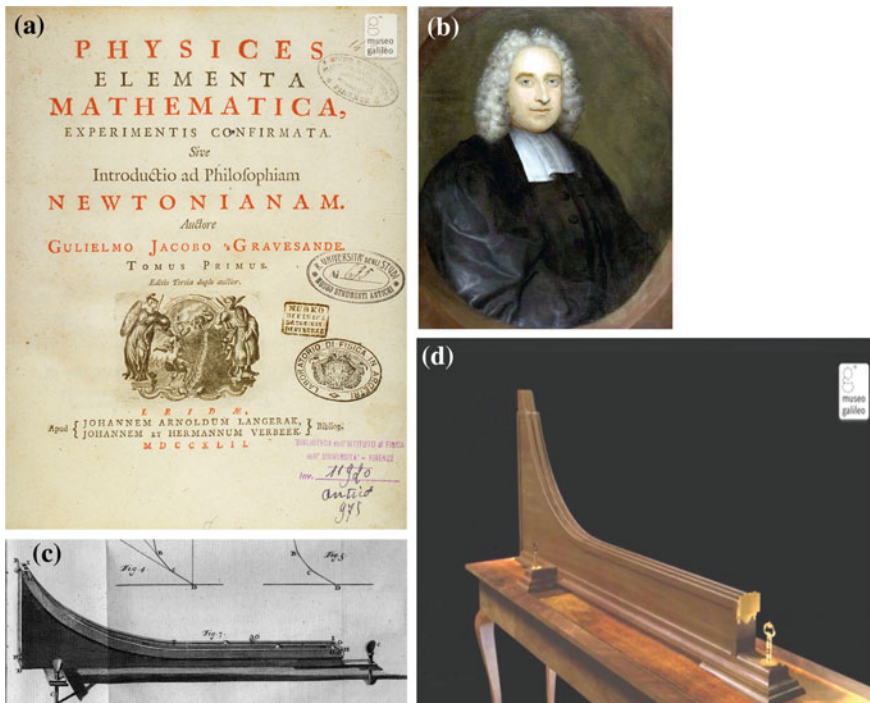
from the bottom may be written in the form  $s_P = 4r \sin(\varphi/2)$ , where  $r$  is the radius of the generating circle,  $\varphi$  is its rolling angle and  $\varphi/2$  is also the local slope at  $P$ . Thus, the gravitational restoring force is proportional to  $s_P$  and the equilibrium of the point mass  $P$  along the path yields,

$$m\ddot{s}_P = -mg \sin\left(\frac{\varphi}{2}\right) \rightarrow \ddot{s}_P = -\frac{gs_P}{4r} \rightarrow \dot{s}_P^2 = -\frac{g}{4r} (s_P^2 - s_{P,\max.}^2), \quad (1)$$

whence, integrating again, the sliding time from the top position to the bottom turns out to be the same for any starting position:

$$\frac{T_{\text{sliding}}}{2} \sqrt{\frac{g}{r}} = \left| \sin^{-1}\left(\frac{s_P}{s_{P,\max.}}\right) \right|_{0}^{s_{P,\max.}} = \sin^{-1}(1) \rightarrow T_{\text{sliding}} = \pi \sqrt{\frac{r}{g}}. \quad (2)$$

The tautochronous property of the cycloidal path was experimentally proved by the Dutch scientist W.J. Gravesande, using the device shown in Fig. 11, which was described in his treatise “*Physices Elementa Mathematica*” and has been recently



**Fig. 11** **a** Gravesande’s treatise “*Physices Elementa Mathematica*”. **b** Willem Jacob’s Gravesande. **c** Device for experimental tests on the cycloid tautochronism (by Gravesande). **d** Reconstruction of Gravesande’s device by Museo Galileo, Florence. Copyright of *Museo Galileo*, photographic archives, Florence

reconstructed by the “Museo Galileo” in Florence. Letting two balls roll along two identical cycloidal tracks, starting from two different rest positions, they arrive together at the bottom, though they cross the finishing line with different velocities because of the law of the conservation of energy (see Eq. 1).

The tautochronous property of the cycloid is strictly associated with the isochronism of the cycloidal pendulum. Figure 12 shows that, when the flexible red ribbon  $OMP$  oscillates, wrapping and unwrapping the two rigid cycloidal bands generated by a circle of diameter  $2r$ , the point mass  $P$ , which is located at a distance  $4r$  on the ribbon, describes a cycloidal trajectory equal to those bands, but shifted a distance  $2r$  in the downward direction and symmetrically placed between them (involute of the upper rigid cycloids).

Actually, as  $s_M = 4r - MP = 4r - MP_0 = 4r[1 - \sin(\pi/2 - \psi/2)]$  (see Fig. 10 and previous discussion on tautochronism), one has

$$\begin{aligned}
 x_P &= x_M + (4r - s_M) \cos(\psi/2) \\
 &= r(1 - \cos \psi) + 4r \cos^2(\psi/2) = 2r + r(1 + \cos \psi), \\
 y_P &= y_M + (4r - s_M) \sin(\psi/2) \\
 &= r(\psi - \sin \psi) + 4r \sin(\psi/2) \cos(\psi/2) = r(\psi + \sin \psi),
 \end{aligned}
 \tag{3a, b}$$

which are just the parametric equations of the lower cycloid.

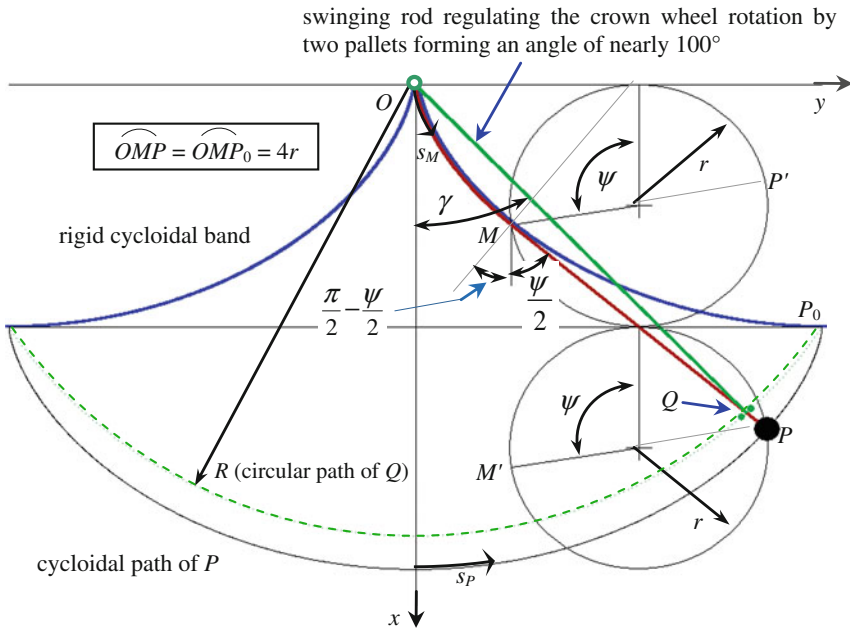


Fig. 12 Isochronism of the cycloidal pendulum



The oscillation period is four times the time interval elapsed between the maximum amplitude position and the bottom position, and thus, the oscillations are isochronous due to the tautochronism properties of the cycloidal path.

The brachistochronous property of the cycloids is also interesting, though of minor concern for the pendular motion. The space covered by a point mass to slide from a fixed upper position to a fixed lower position along a generic path should be calculated by integrating the following expression:

$$\frac{ds}{dt} = \frac{dy}{dt} \sqrt{1 + \left(\frac{dx}{dy}\right)^2} = \sqrt{2g(x_0 - x)}, \quad (4)$$

where the subscript 0 indicates the starting level. Hence, putting  $x_0 - x = X$  and indicating with a prime the differentiation with respect to  $y$ , one has

$$\sqrt{2g} \times dt = dy \times \sqrt{\frac{1 + X'^2}{X}} = dy \times f(X, X') \quad \text{where} \quad f = \sqrt{\frac{1 + X'^2}{X}}. \quad (5a, b)$$

The condition that the sliding time to pass from level  $x_0$  to level  $x < x_0$  is the shortest one implies minimization of the integral of the right hand of Eq. (5a) from  $y_0$  to  $y$ , whence the Euler-Lagrange equation is

$$\frac{df}{dX} - \frac{d}{dy} \left( \frac{df}{dX'} \right) = 0. \quad (6)$$

Replacing the function  $f$  by Eq. (5b), the solution of Eq. (6) can be found to be  $X(1 + X'^2) = \text{constant} = 2r$ , which gives  $X' = \pm\sqrt{2r/X - 1}$ . Hence one gets, integrating again,

$$\pm(y - y_0) = \sqrt{X(2r - X)} + 2r \tan^{-1} \sqrt{2r/X - 1}. \quad (7)$$

This is just the Cartesian equation of the cycloid passing through the point  $(x_0, y_0)$  and stemming from the rolling motion of a circle of radius  $r$  under a straight horizontal base line. Actually, replacing  $X = r(1 + \cos\psi)$ ,  $(y - y_0) = \pm r(\psi + \sin\psi)$  into Eq. (7), an identity is obtained.

## 2.2 The Structure of Galilei's Clock Mechanism. Ideal and Actual Operation

The ideal oscillation period of the simple pendulum may be calculated by well-known procedures ignoring the impulse supply and the energy dissipation in the whole clock mechanism. Defining the swing angle by  $\theta$  (e.g., positive in the anticlockwise direction), introducing the dimensionless time variable  $\tau = \omega_n t$ , where

$\omega_n = \sqrt{g/l}$  and indicating the derivatives with respect to  $\tau$  with primes, the motion equation shows the familiar trigonometric law of the restoring force

$$\theta'' + \sin \theta = 0. \tag{8}$$

The first integration gives

$$\frac{\theta'^2}{2} = 2 \left( \sin^2 \frac{\Theta}{2} - \sin^2 \frac{\theta}{2} \right), \tag{9}$$

where  $\Theta$  is the oscillation amplitude.

Hence, putting  $\sin^2(\Theta/2) = k^2$  and  $\sin^2(\theta/2) = k^2 \sin^2 u$ , the change of the variable from  $\theta$  to  $u$  leads to a Legendre normal form, which permits calculating the dimensionless oscillation period  $T$  by the second integration

$$d\tau = \frac{du}{\sqrt{1 - k^2 \sin^2 u}} \rightarrow T = 4K(k) = 4K \left( \sin \frac{\Theta}{2} \right), \tag{10a, b}$$

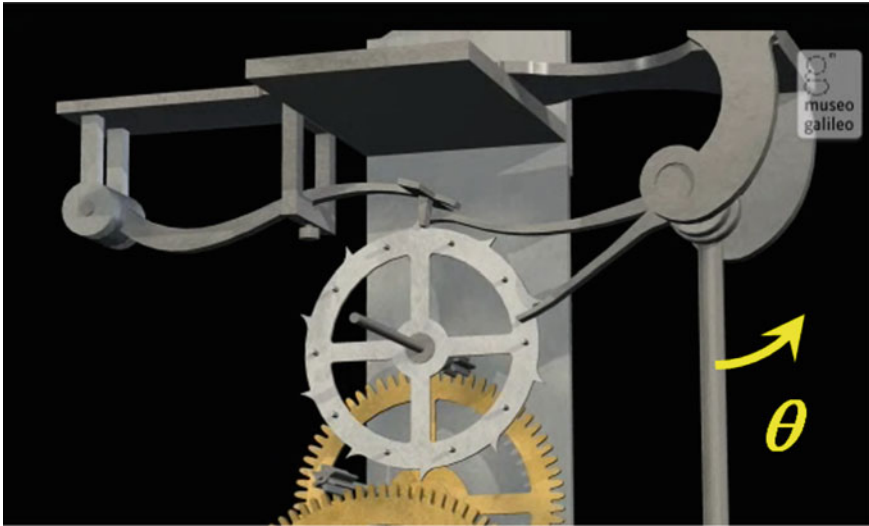
where  $K(k)$  stands for the complete elliptic integral of the first kind with modulus  $k$ . This result reveals the dependence of the period on the swing amplitude and, as the complete elliptic integral  $K(k)$  is equal to  $\pi/2$  for  $k = 0$  and is an increasing function of  $k$ , the period decreases monotonically on decreasing the amplitude and approaches the harmonic period  $2\pi$  for small oscillation widths.

The cycloidal pendulum described by Huygens in his treatise “*Horologium Oscillatorium sive de motu pendulorum*” in 1673 is not affected by this drawback, because it is based on the tautochronous property of the cycloidal trajectory, along which a point mass always slides down in the same lapse of time under the influence of gravity regardless of its starting position.

However, a deeper reflection is here advisable on the fact that, strictly speaking, all the above considerations on the ideal isochronism or non-isochronism of pendular motion are somewhat illusory in practice, due to the unavoidable friction losses present in the whole clock assembly and to the consequent impulse supply necessary to provide the dissipated energy periodically.

Figure 13 shows a mechanical reconstruction of Galilei’s clock prototype on the basis of Viviani’s design and clearly highlights the functionality of the Galilean escapement. The escapement wheel has ten ratchets on the crown and ten front pegs. Its intermittent motion is controlled by a catch, which is slightly loaded by a thin spring, and by two curved levers fastened to the pendulum hinge.

On approaching the left dead position of the pendulum near the oscillation end, for a certain angle  $\theta_1 < 0$ , the upper releasing lever raises the catch until the wheel is left free and rotates to contact the lower impulse lever with its peg (pendulum position  $\theta_2$ ). After a short recoil to reach the dead position, the wheel peg pushes the impulse lever until leaving it for  $\theta = \theta_3$ , near the right dead position, providing the energy lost by friction during the cycle.



**Fig. 13** Reconstruction of Galilei's escapement on the basis of the design of Vincenzo Viviani and Vincenzo Galilei. Copyright of *Museo Galileo*, photographic archives, Florence

Considering the actual operation of the pendulum machine, Eq. (8) changes into

$$\theta'' + \theta = \theta - \sin \theta + \frac{M_{\text{mot.}}(\theta)}{mgl} - \frac{M_{\text{hinge}} \text{sgn}(\theta')}{mgl} - \frac{M_{\text{air}} \text{sgn}(\theta')}{mgl} \omega_n^\mu |\theta'|^\mu + \frac{M_{\text{rel.}}(\theta)}{mgl}, \quad (11)$$

where  $m$  is the pendulum mass and the four moments  $M$  are defined as follows:

- $M_{\text{mot.}}$  is the motive torque acting on the impulse lever, which varies with the pendulum tilt, is active from the starting position  $\theta_2$  up to the final one  $\theta_3$ , where the peg leaves the impulse lever, and is proportional to the mutual force between the peg and the lever. This force is in turn proportional to the driving torque  $M_0$ , applied to the escapement wheel by the motor weight through the whole gear train, and is also a function of  $\theta$  and of the sliding direction of the peg, which determines the sign of the friction angle.
- $M_{\text{hinge}}$  is the absolute value of the friction torque in the pendulum hinge.
- $M_{\text{air}}(\omega_n \theta')^\mu$  indicates the air resistance, which is supposed to be a function of the  $\mu$ th power of the oscillating velocity, where  $\mu$  is  $>1$ .
- $M_{\text{rel.}}$  is the moment of the force necessary to release the ratchet, which is supposed active between the positions  $\theta_1$  and  $\theta_2$ , of beginning and ending of the contact between the releasing lever and the catch (it is supposed that the peg contacts the impulse lever immediately after the wheel release).

The dissipative torque  $M_{\text{hinge}}$  in the pendulum hinge is piece-wise continuous and constant and changes its direction at the motion inversion, whereas the torque  $M_{\text{air}}$ , due to the air resistance, is continuous and depends on the oscillation speed. These two torques are both active during the whole period. The releasing torque  $M_{\text{rel.}}$  may be assumed constant but is active only during a short fraction of the period. The moving torque  $M_{\text{mot.}}$  is also active during a partial fraction of the oscillation period, from  $\theta_2$  to  $\theta_3$ , and though the driving torque  $M_0$  exerted on the escapement wheel by the gears may be plausibly considered constant, yet  $M_{\text{mot.}}$  varies with the position on the impulse lever of the contact point with the peg and also depends on the direction of the sliding friction. The total force between the peg and the lever can be calculated by the rotational equilibrium condition of the escapement wheel and permits calculating  $M_{\text{mot.}}$  by imposing the rotational equilibrium of the impulse lever. The relation between  $M_{\text{mot.}}$  and  $M_0$  is somewhat complex and is not reported. Here, it is only mentioned that this relation depends on the pendulum angle  $\theta$ , on the radial position of the pegs, on their diameter, on the angle between the lever and the pendulum rod, on the offset of the lever with respect to the centre of the pendulum hinge and on the sliding direction.

Assuming one of the previous tilt angles  $\theta$  as a small reference parameter  $\varepsilon$ , e.g.,  $\theta_1 = \varepsilon$ , scaling all the angles  $\theta$  by  $\varepsilon$  and minding the series expansion of the sine function, the difference  $\theta - \sin\theta$  is of order  $\varepsilon^3$ . If one supposes that all four dimensionless moments of Eq. (11) exert an influence on the pendulum motion that is comparable with the gravitational nonlinearity, they must be regarded as of order  $\varepsilon^3$  as well. Otherwise, some of them may be regarded as of a lower or higher order of magnitude, i.e., of order  $\varepsilon^n$  with  $n \neq 3$ .

The right hand of Eq. (11) is characterized by discontinuities of the first kind, but, looking only for a first order approximation of the solution, an averaging approach of the Krylov-Bogoliubov (K-B) type appears appropriate (Krylov and Bogoliubov 1947). Putting  $\theta = \varepsilon\beta$ , letting  $\beta = B\sin(\tau + \phi)$  be the zero order solution (for  $\varepsilon \rightarrow 0$ ) and indicating the right hand of Eq. (11) with  $\varepsilon^3 F(\beta)$ , the K-B procedure assumes that  $B$  and  $\phi$  are not two constants but two functions of  $\tau$  and eliminates the new degree of freedom that is being introduced by imposing the further condition  $\beta' = B \cos(\tau + \phi)$ , whence

$$\begin{aligned} B' \sin(\tau + \phi) + B\phi' \cos(\tau + \phi) &= 0, \\ B' \cos(\tau + \phi) - B\phi' \sin(\tau + \phi) &= \varepsilon^2 F(\beta), \end{aligned} \quad (12a, b)$$

and consequently,

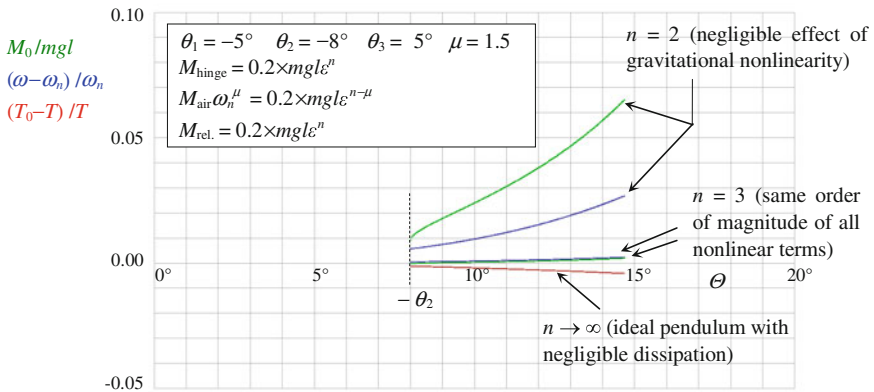
$$B' = \varepsilon^2 F(\beta) \cos(\tau + \phi), \quad B\phi' = -\varepsilon^2 F(\beta) \sin(\tau + \phi). \quad (13a, b)$$

Equations (13a, b) imply that  $B$  and  $\phi$  are slowly varying functions of  $\tau$ , and thus, they can be approximately averaged in the short period  $2\pi$  neglecting their variation:

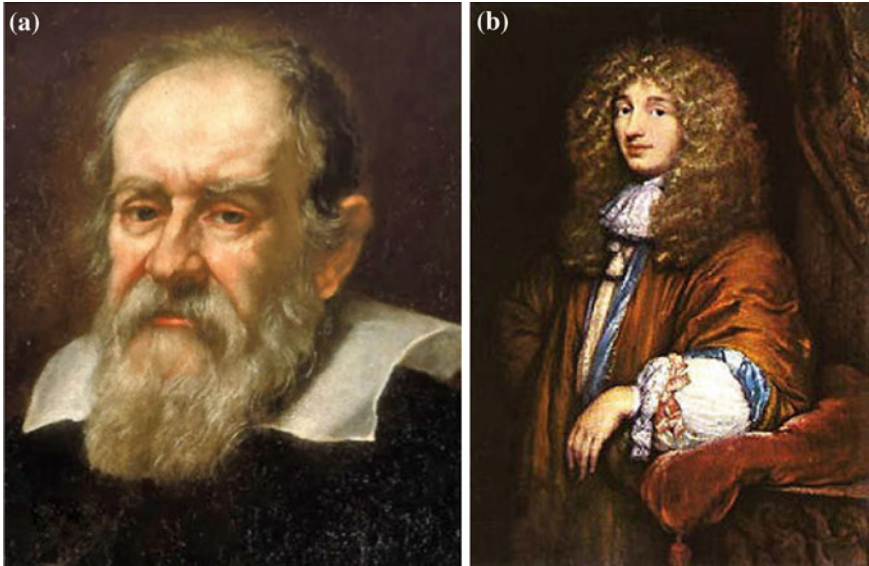
$$\begin{aligned}
 B' &\cong \frac{\varepsilon^2}{2\pi} \int_0^{2\pi} F(\beta) \cos(\tau + \phi) d(\tau + \phi), \\
 B\phi' &\cong -\frac{\varepsilon^2}{2\pi} \int_0^{2\pi} F(\beta) \sin(\tau + \phi) d(\tau + \phi).
 \end{aligned}
 \tag{14a, b}$$

Therefore, fixing the functional dependence on  $\theta$  of the three dimensionless dissipative moments,  $M_{\text{hinge}}/(mgl)$ ,  $M_{\text{air}}(\omega_n \varepsilon)^\mu/(mgl)$  and  $M_{\text{rel.}}/(mgl)$ , which are contained in  $F(\beta)$ , and assuming steady oscillations ( $B' = 0$ ), it is possible to solve for the required driving torque  $M_0$  and for the frequency change  $\omega_n \phi'$  depending on the oscillation amplitude  $\Theta = \varepsilon B$ .

Figure 14 illustrates these results with an example case and shows the difference between two choices of the order of magnitude of the four moments  $M_{(\dots)}$  in Eq. (11):  $n = 2$  indicates that the nonlinear gravitational effect is of a lower order, whereas this effect is comparable with the dissipative and impulsive effects for  $n = 3$ . The red curve gives the theoretical dependence of the period on the amplitude and corresponds to an exponent  $n \gg 3$ . The exponent  $\mu$  of the air resistance was fixed to the value  $\mu = 1.5$ , in the implicit hypothesis of an intermediate viscous-turbulent condition. What is most interesting in the results is that the overall effect of the driving impulse and the dissipation sources somehow counterbalances the period increase of the ideal pendulum in increasing the oscillatory amplitude and may even isochronize the motion in particular conditions under which the nonlinear effects are all comparable with each other.



**Fig. 14** Dimensionless driving torque on escapement wheel  $M_0/mgl$  (in green) and angular frequency relative change  $(\omega - \omega_n)/\omega_n$  (in blue) versus oscillation amplitude  $\Theta$ , for two values of the order  $n$ . Nonlinear period change of ideal pendulum (in red),  $T_0 = 2\pi$ ,  $T = 4K(k)$



**Fig. 15** **a** Galileo Galilei (Pisa 1564, Arcetri 1642); **b** Christiaan Huygens (The Hague 1629, The Hague 1695)

### 3 Conclusive Remarks

An animated debate arose in the 17th century between the Dutch scientist Christiaan Huygens and Galilei's heirs, Vincenzo Viviani and Vincenzo Galilei, about the primacy of the invention and construction of the first pendulum clock (Fig. 15). What we may conclude now is that both were to be considered fathers of this ingenious instrument: Galilei for studying the laws of pendular motion first, understanding their application in the measurement of time and conceiving the pendulum clock; Huygens for his successful discovery of the tautochronous property of the cycloidal trajectory, which permits attaining the theoretical pendulum isochronism, and for the actual construction of the first pendulum clock.

A careful analysis of the combined effects of the unavoidable dissipation sources present in the clock assembly and of the necessary periodic impulses to be provided in order to restore the lost energy highlights the slight deviation of the real operation from the ideal theory, the results of which then appear somewhat illusory, and suggests the possible isochronization of the simple pendulum motion under particular dissipation conditions.

**Acknowledgement** The *Museo Galileo* in Florence is gratefully acknowledged for providing photographic documentation.

## References

- Diderot D, d'Alembert JIR (eds) (1751–1772) *Encyclopédie, ou Dictionnaire Raisonné des Sciences, des Arts et des Métiers*, Paris
- Headrick MV (2002) Origin and evolution of the anchor clock escapement. *IEEE control systems magazine*, April 2002
- Huygens C (1673) *Horologium Oscillatorium sive de motu pendulorum* (trans: Bruce I)
- Krylov N, Bogoliubov N (1947) *Introduction to non-linear mechanics*. Princeton University Press, New Jersey

# Machine Designs and Drawings in Renaissance Editions of *de Architectura* by Marcus Vitruvius Pollio

Michela Cigola and Marco Ceccarelli

**Abstract** This paper is focused on machine designs of the Renaissance period through drawings reproducing Vitruvius's machines from Book X of his *De Architectura*. The editions by Fra' Giovanni Giocondo in 1513, Cesare Cesariano in 1521, and Daniele Barbaro in 1584 are used to analyze machine designs and drawings, both as an interpretation of Roman machines and inspiration for Renaissance designs.

## 1 Vitruvius and His Work

Most of the Roman engineers have remained unknown, since the practice of engineering at the time was not, in large part, made to be visible within the work's paternity and its written publications. In addition, during the time of the Roman Empire, the engineering practice was carried out mainly within state frames through the military corps, (Ceccarelli and De Paolis 2008). However, we do have evidence of Roman mechanical Engineering, not only as a result of the very durable infrastructures of Civil Engineering that required machines but also from technical publications that have reached us through republication and reconsideration since the Middle Ages and the Renaissance. Beside these few works, there are great recollections of personalities who contributed considerably to Roman Engineering and its visibility through the centuries. Marcus Vitruvius Pollio (Fig. 1) is one those Roman engineers (Cigola and Ceccarelli 2014).

Marcus Vitruvius Pollio (80/70 B.C. circa—25 B.C.) is known as having been an architect and engineer. Indeed, in the Antiquity and in the time up to the

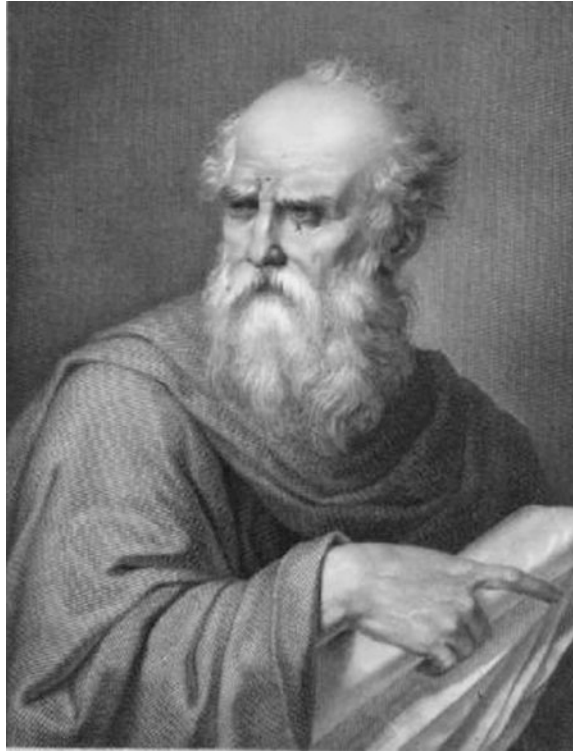
---

M. Cigola  
DART, University of Cassino and South Latium, Cassino, Italy  
e-mail: cigola@unicas.it

M. Ceccarelli (✉)  
LARM, University of Cassino and South Latium, Cassino, Italy  
e-mail: ceccarelli@nicas.it



**Fig. 1** Presumed portrait of Marcus Vitruvius Pollio (80/70 B.C. circa—25 B.C.)



Industrial Revolution, there was no distinction between architect and engineer, and the term architect was the only one used to address technical experts in design and construction of systems (machines or buildings), as pointed out in (Ceccarelli 2004). Of Vitruvius's life, we do not know much more than that he was an officer in charge of war machines under Julius Caesar, and then an architect under Augustus.

Vitruvius wrote the treatise *De Architectura* in ten books (today we would call them chapters), most likely between 27 and 23 B.C., since he dedicated it to Augustus. The treatise was rediscovered in the Renaissance and, since its translation into Italian in 1414 by Poggio Bracciolini, and another one later in 1584 by Daniele Barbaro, it has addressed a lot of attention from both technical and literary viewpoints. The significance of the treatise can also be recognized by the fact that it was cited in other works in the Antiquity.

The treatise *De Architectura* is composed of ten books dealing with the following subjects: I—Formation of an architect, II—Origin and development of construction techniques, III and IV—Holy buildings, V—Public buildings, VI and VII—Private buildings, VIII—Hydraulic engineering, IX—Solar clocks with elements of astronomy and astrology, X—Machines and elements of mechanics.

The aim of Vitruvius' work was to outline the figure and formation of a clever architect within a strong cultural basis and a very complementary knowledge of machines, as indicated by the fact that only Chap. 10 is specifically dedicated to machines.

The reproduction and interpretations of Vitruvius's text from the Middle Ages manuscript were worked out by several authors by including machine drawings, the most relevant of which can be considered to be (Fra' Giocondo 1511, 1513; Cesariano 1521; Durantino Francesco Luci 1535; Ryff 1575; Barbaro 1584; Perrault 1675; Galiani 1790; Viviani 1832). The many editions and several publications are indicative of the considerable interest in Vitruvius's work, but also of the complexity surrounding the quest for a commonly accepted version of the interpretation of the original Latin text, with the help of suitable drawings.

The difficulty of interpreting the original Latin text was due mainly to mistakes in copying by those rewriting the text in the Middle Ages, different possibilities for interpretation of technical terms and machine features, and also because no drawings or schemes, if any by the Roman author existed, were reproduced in the copies published in that period. Thus, in the Renaissance, the translation, but also the interpretation at technical and historical levels, gave rise to strong disputes and discussions among those who were interested in Vitruvius's work.

The interest in Vitruvius's work was motivated mainly by the rediscovery of the Roman literature on technical aspects, both in the interest of understanding the role of Technique in Roman culture and the revitalizing of successful machines as inspiration for new ones. Those two different viewpoints attracted both humanists and technicians, who thus had the chance to interact and collaborate, giving a dignity of discipline to the activities for design and operation of machines.

The following editions of *De Architectura* by Vitruvius can be considered the most important reproductions of his work:

- 1486 by Sulpicio da Veroli and Pompolio Leto, edited in Rome. (editio princeps)
- 1496 Florentine edition (no more indications)
- 1497 Veneto region edition (no more indications)
- 1511 by Fra' Giocondo, edited in Venice (first illustrated edition)
- 1521 by Cesare Cesariano, edited in Como (first commented and illustrated edition)
- 1535 by Durantino, edited in Venice
- 1536 by Giovan Battista Caporali, edited in Perugia
- 1547 by Jean Martin and Jean Gujon, edited in Paris (first French edition)
- 1552 by Guillaume Philandrier, edited in Lion (first commented French edition)
- 1556 by Daniele Barbaro, edited in Venice.
- 1564 by Lazaro de Velasco, manuscript (first Spanish translation)
- 1575 by W.H. Ryff, edited in Basel (first German edition)
- 1582 by Miguel de Urrea, edited in Alcala de Henares (first Spanish edition)
- 1624 by Henry Wotton, edited in Amsterdam (first English translation)
- 1660 by Giovanni Antonio Rusconi, edited in Venice
- 1675 by Claude Perrault, edited in Paris
- 1739–41 by Giovanni Poleni, edited in Padua

1771 by William Newton, edited in London (first English edition Books 1–5)

1790 by Bernardo Galiani, edited in Siena

1791 by William Newton, edited in London (first English edition ten Books)

1831–32, by Quirico Viviani, edited in Udine

## 2 A Comparative Analysis of Machine Designs

In this work, attention is focused on machine designs that are described in Book X —Machines and elements of mechanics, referring to the editions reproducing Vitruvius's works by Fra' Giocondo (1513), Cesariano (1521), Barbaro (1584) during the Renaissance. In particular, the study looks at machines for civil application and war machines with the aim of demonstrating the evolution of interpretations and machine design through representative drawings.

In general, the drawings by Fra' Giocondo show the functional structure of a machine with indications of its main components in small letters. The operation is quite easily understandable, although the possibility of practical implementation lack detail in design parts and connections.

The machine designs by Cesariano are illustrated with many details, with the main parts being indicated by small letters that are used in the text for comments. The machine designs look like solutions from practice current to Cesariano's time, perhaps to stress the practical feasibility of Vitruvius's machines.

The representations by Barbaro present a mixture of characters from the previous works by Fra' Giocondo and Cesariano. Namely, the machine designs are clearly represented to show the overall design and its conceptual operation. But details of construction are given only partially. Barbaro always includes human figures in the drawings to make clear how a machine is operated but also to stress its size and power.

### 2.1 *Archimedes' Screw Pump*

The design of Archimedes' screw pump is shown in Figs. 2, 3 and 4. While Fra' Giocondo and Barbaro give quite similar designs with very generalized features, Cesariano gives us three different and quite detailed representations of the screw pump, although it is not clear where the power source for operation is located. In the other two cases, a large turbine wheel is represented as co-axial to the screw, but the function of the assembly is not yet evident.

From an artistic viewpoint, the representation by Fra' Giocondo in Fig. 2 is very synthetic, with half of the figure beyond the horizon being empty. Careful attention

**Fig. 2** Archimedes screw pump in Fra' Giocondo's edition of 1513, p. 172 v

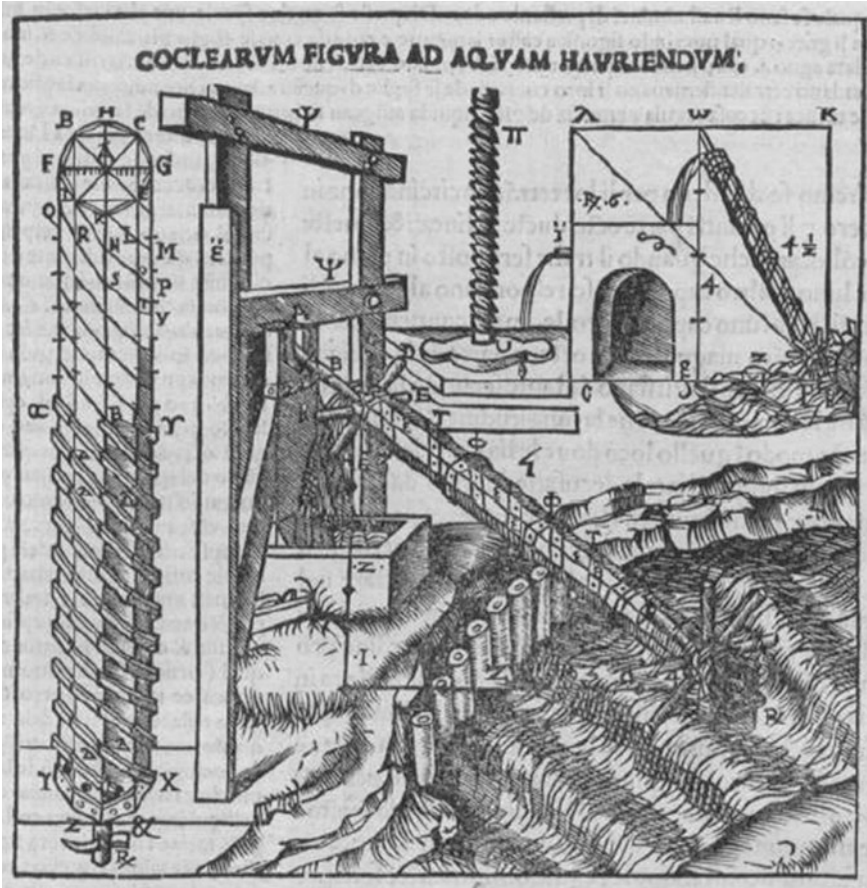


is addressed to the water flow and the machine parts that dip into it, and the environment is carefully depicted, with a tree on the left and broken riverbanks. Nevertheless, the drawing looks planar, with no 3D indications except for the chiaroscuro in the vertical frame bar of the pump.

The mechanical design is outlined with essential information that still permits understanding of the operation and its success, but it lacks detail for a practical reproduction. Supports and bearings are not illustrated, and the mechanical design of the Archimedes screw is not represented with the necessary profiles within the cylinder. Even the turbine that gives power to the pumping screw is attached coaxial to the screw pump, but with an indefinite connection, so that it is not technically clear how the system is fully arranged.

The drawing by Cesariano in Fig. 3 is much more accurate than the one by Fra' Giocondo, thanks to a 3D view with chiaroscuro applications for everything and the ruffling flow of the river water. Cesariano also gives clear indications of the working of the screw pump through a scheme on the left that displays the screw in a naturalist pictorial representation that gradually turns into a very schematic design up at the top. This can be understood as an early kinematic scheme with a vision that is quite modern for the time.

The mechanical design is stressed in several details from theoretical modeling up to manufacturing and assembly solutions. In particular, the theory of functioning is stressed through the geometry of the screw, which is also indicated through the use

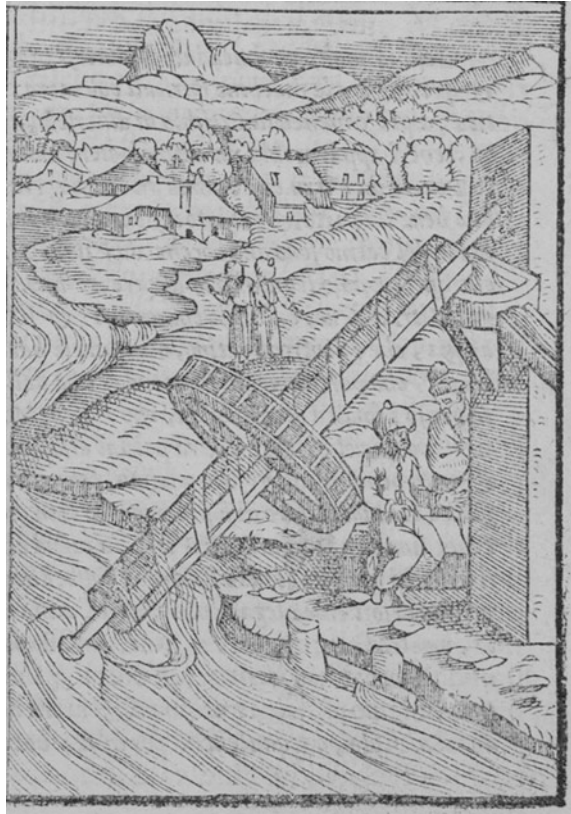


**Fig. 3** Archimedes screw pump in Cesariano's edition of 1521, p. CLXXI v

of characteristic points at the front left of the drawing. One drawing is devoted to showing the screw once built. The application of the pumping is indicated as a function of its slope in the background drawing. The power source is generically indicated with different manners of turbines, which, nevertheless, are not accurate in their connections with the screw, since the primary focus here is the screw itself.

Barbaro crafts the drawing in Fig. 4 as similar to the one by Fra' Giocondo, although with somewhat more detail in the naturalistic representation of the background. He represents two persons near the screw to give an indication of the size of the machine, but, curiously, one of them is dressed in Turkish clothes and a turban.

**Fig. 4** Archimedes screw pump in Barbaro's edition of 1584, p. 463

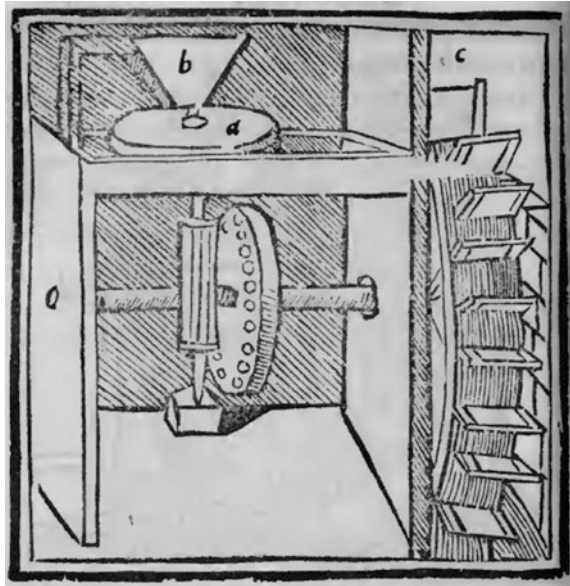


The mechanical design is more realistic than the one by Fra' Giocondo, since the pivot in the water is clearly sized and the support on the tower frame is clearly outlined, even if the bearings are not illustrated. The screw is represented with clear profiles and the powering turbine is well connected with the cylinder of the screw pump, so that the mechanical design looks more realistic towards practical application.

## 2.2 *Hydraulic Flour Mill*

The main attention of the mechanical design in all three drawings in Figs. 5, 6 and 7 is addressed toward the transmission that is used to convert the axial rotation of the hydraulic wheel into the vertical rotation of the mill wheel. The core of the machine

**Fig. 5** Water mill in Fra' Giocondo's edition of 1513, p. 171 v



is considered to be the mechanical transmission, which is shown with the same design of a vertical lamp cage that is engaged by the rod teeth of a large flywheel.

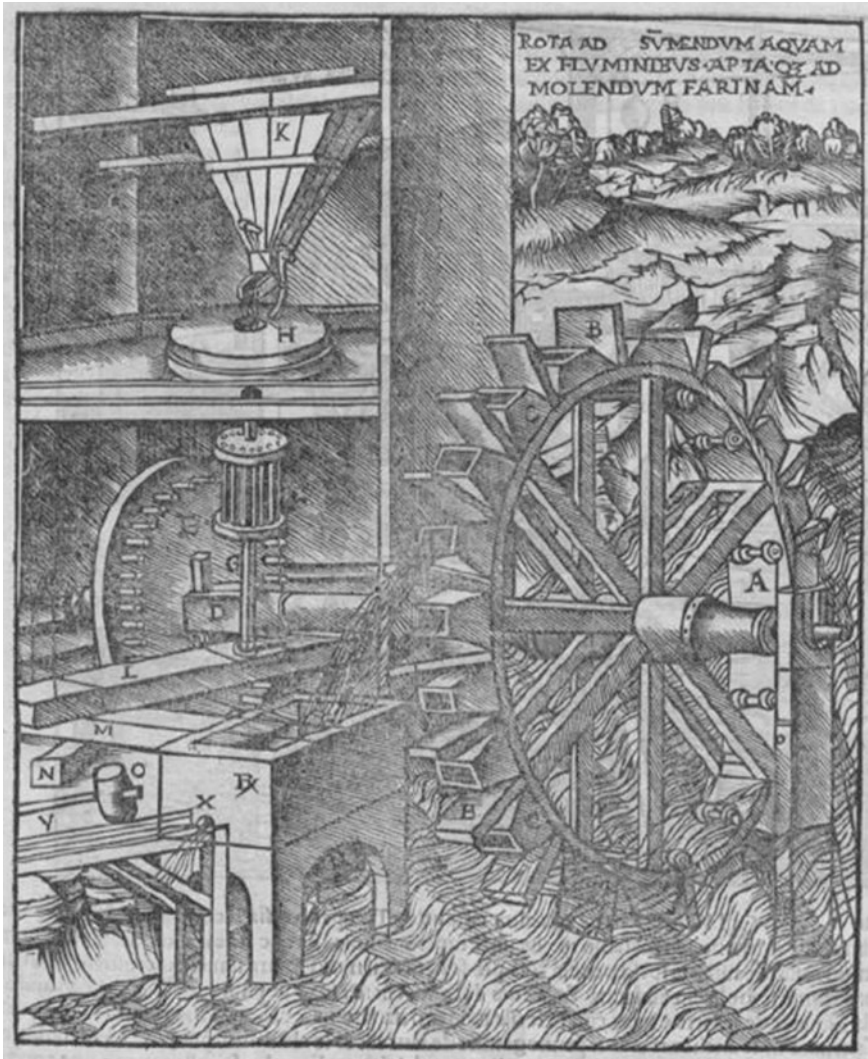
From an artistic viewpoint, Fra' Giocondo's drawing in Fig. 5 gives a lean representation of the mill machine with few chiaroscuro parts and few lines indicating the action of the water running the paddle turbine. The building frame is represented like a box, with the back wall drawn in strong diagonal lines.

The mechanical design by Fra' Giocondo is essentially a representation of the machine's big primary parts, seemingly more interested in explaining the components of the machine than its assembly, which is somehow incomplete or incorrect, since the gears cannot be understood as completely engaged and the milling wheel is not well-positioned.

In Fig. 6, Cesariano shows the mill within its natural environment, with rocks and trees in the background drawn with the same great attention shown to the water flow. Interesting is the almost frontal view of the machines with respect to the direction observed from the hydraulic wheel in order to represent the building as rotated somewhat so as to show the complementary devices at the bottom left of the drawing.

Cesariano shows the full machine with parts in proper relative proportion, each part illustrated with mechanical detail, including the powering hydraulic wheel.

In Fig. 7, Barbaro enriches the drawing with two figures of millers, so as to give indication of the size of the mill. The drawing has the same view as the one given by Fra' Giocondo, with the paddle turbine that is almost hidden by the limited space between the building wall and the drawing's border. The naturalistic representation



**Fig. 6** Water mill in Cesariano's edition of 1521, p. CLXX

is centred on the milling action, with the environment poorly represented by just a profile of a mountain in the background, and few lines for the sky and water flow.

Barbaro focuses attention on the mechanical design of the mill action, providing a frontal cut in the frame of the milling case for the purpose of showing how the miller moves within the case. All the parts are properly sized and assembled, although the connection with the powering hydraulic turbine is not evident and the engagement of the gears is not clear.





Fig. 7 Water mill in Barbaro's edition of 1584, p. 463

### 2.3 Cranes

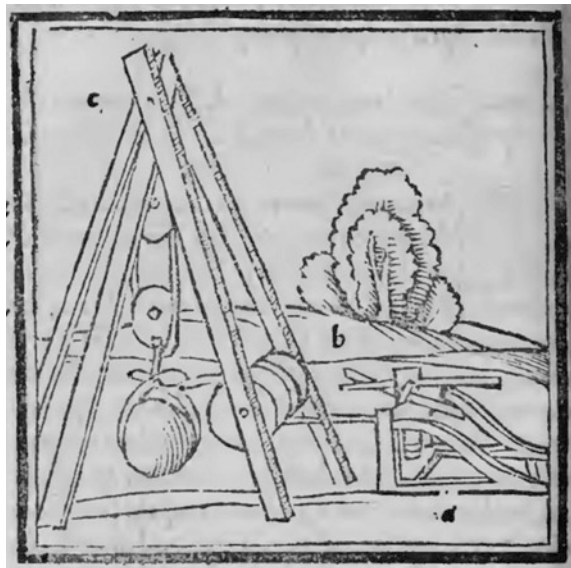
The examples of crane solutions in Figs. 8, 9 and 10 show very different approaches in describing the cranes, and represent a clear example of how great a role interpretation plays in obtaining different views by different authors taking into account theoretical considerations and practical features of implementation of the described machines.

From an artistic viewpoint, in Fig. 8, Fra' Giocondo shows the crane in a very synthetic environment represented merely through a few lines. The attention is centred on the machine, but the drawing seems not to contain everything there is to be seen, as if to suggest a continuation beyond the drawing's borders. The components are drawn in a 3D representation, which, nevertheless, is not clear in indicating the coupling between them, as can be noted by looking at the top cross of the bars.

Fra' Giocondo shows a mechanical design with the essential parts of a crane: a driving capstan, a cable drum, fixed and mobile pulleys, and a gripping system for weight payloads. The assembly is evident, but, from a mechanical viewpoint, unclear, since the connections and connectors are not indicated.

In Fig. 9, Cesariano gives a more rich presentation, both with a 3D view and machine components. Within the drawing table, Cesariano offers a multitude of devices to lift weights with an approach that is the opposite of the merely essential drawing of Fra' Giocondo. The machines are located one in front of the other with the aim of giving the drawing depth, proudly displaying the high skill evident in the 3D drawing technique through the use of shadows.

**Fig. 8** Crane in a crane n  
Fra' Giocondo's edition of  
1513, p. 164 v



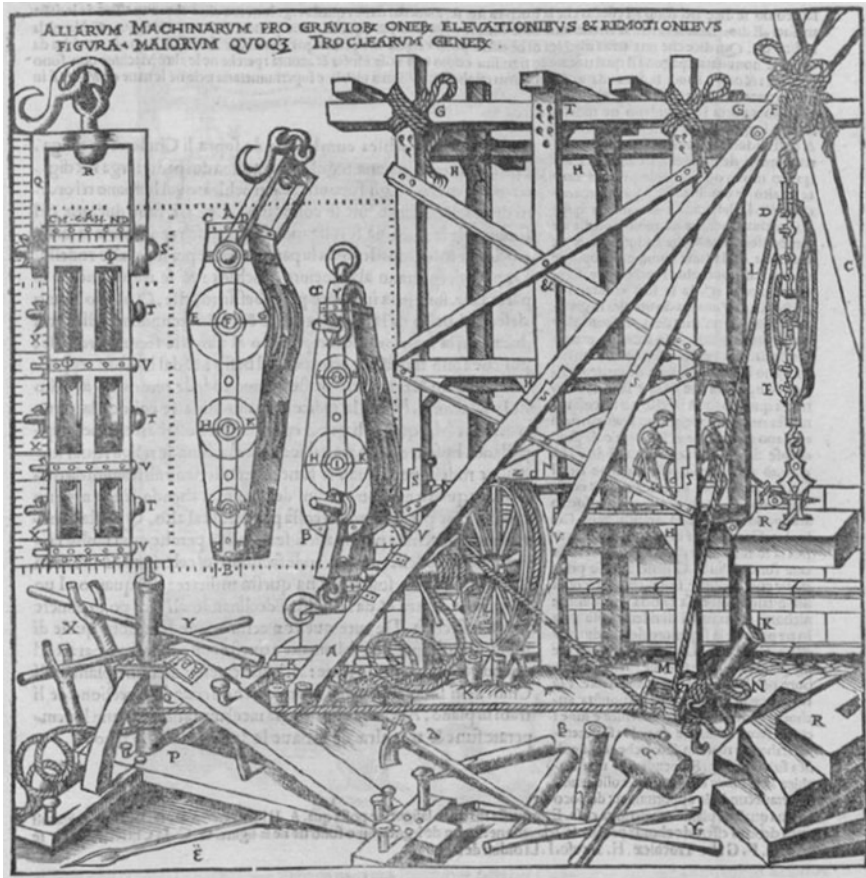


Fig. 9 Crane in Cesariano's edition of 1521, p. CLXV r

Cesariano gives many more details and solutions that come from the current practices of his time, even emphasizing applications for large weight and movements. The mechanical design is appreciable, even for the modern time, in its reference to the pulley assemblies. In this drawing, the great expertise of the author in presenting the details of the mechanical design is just as evident as that of the mechanical engineer using those systems.

In Fig. 10, Barbaro shows a graphical representation which is innovative for the time, but also owes much to Cesariano's edition, since it first draws the main machines followed by the smaller components in order to fill the composition's frame completely. In this case, the depth, shadowing, and chiaroscuro are very accurate and more precise with respect to previous editions, in part because the author of the drawings in Barbaro's book was the famous architect Andrea Palladio (1508–1580).

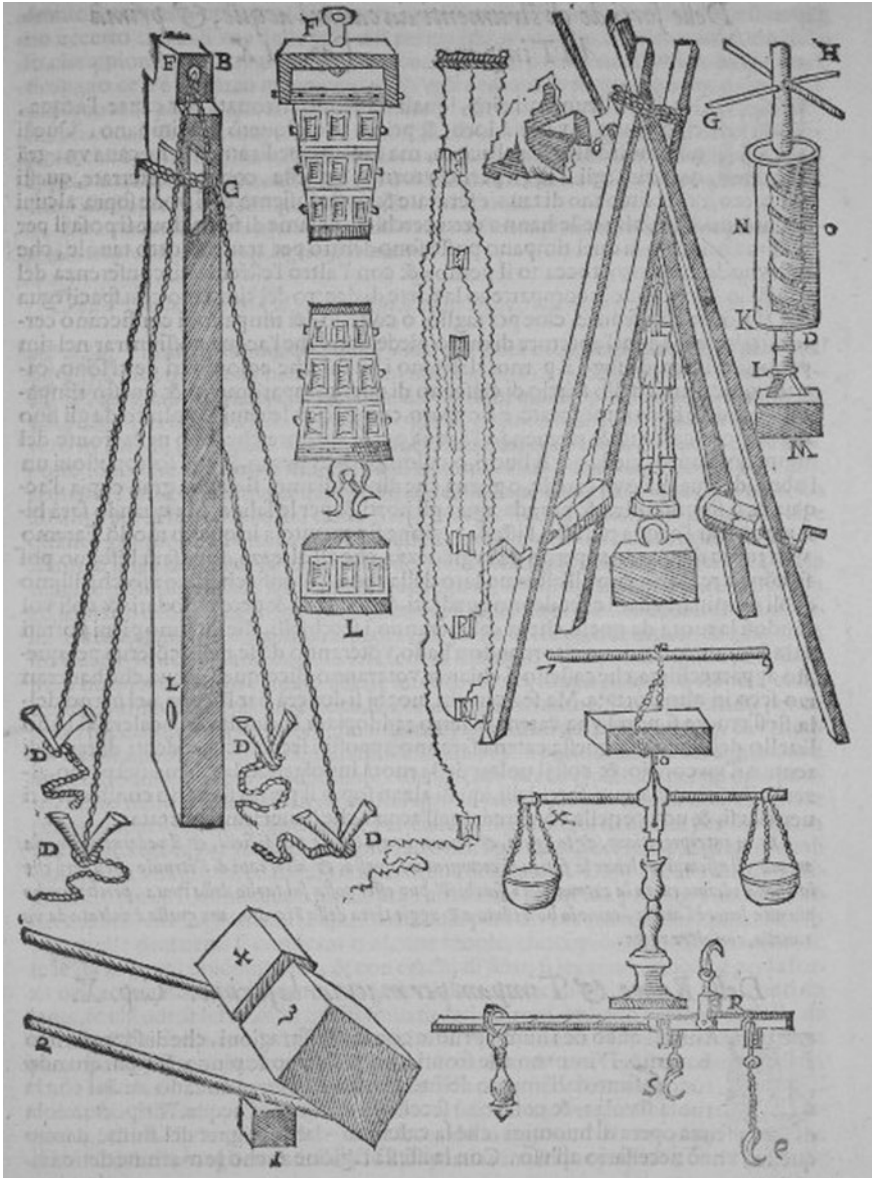


Fig. 10 Crane in Barbaro's edition of 1584, p. 459

Barbaro's drawing table shows the main components of cranes, along with interesting schemes for levers and scales that pretend to explain the basic principle of the mechanics of functioning more than the mechanical design of the crane solutions. Not much attention is addressed to the pulley systems, but a screw lifter is

shown on the right, unusually linked to the cranes so as to indicate the high load capabilities of cranes.

## 2.4 War Machines

The examples of war machines in Figs. 11 and 12 show the complexity in understanding the Vitruvius text and in giving proper representation of war machines from the Roman time. Both figures feature designs contemporary to the respective times of the authors.

In Fig. 11, from an artistic viewpoint, Fra' Giocondo shows a ballista as suspended in an unnatural, empty space, the naturalistic view being limited to the feathers on the extremity of the arrow. The war machine is represented in a pseudo-perspective that gives the drawing depth, indicating the relative position of the parts. It looks like the previous drawing of cranes.

Fra' Giocondo gives the mechanical design of a ballista as a whole, but although several components are well represented, its operation is not clearly understandable, since the assembly lacks the connection of the parts driving the system.

In Fig. 12, Cesariano shows a crowd scenario of war machines as might theoretically be seen on a battlefield. There are soldiers with a hammer and others with catapults in a pictorial view with cleverly use of chiaroscuro, even within the sky, so as to create a dark atmosphere thoroughly appropriate to a depiction of war situations.

**Fig. 11** Balista in Fra' Giocondo's edition of 1513, p. 179 r

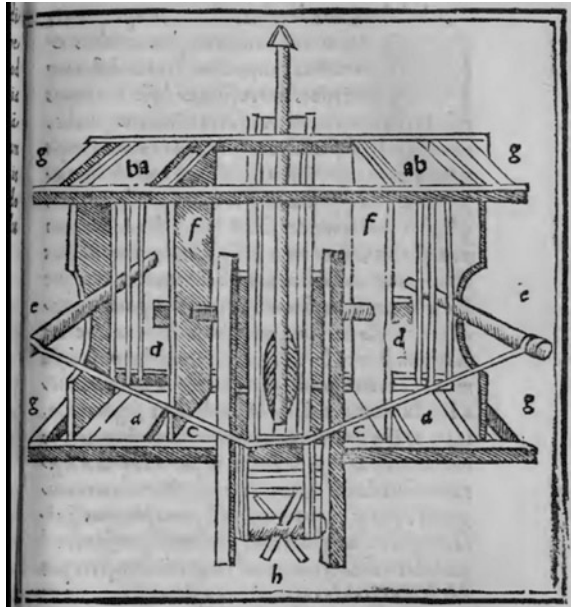




Fig. 12 War machines in Cesariano's edition of 1521, p. CLXXVIII v

Cesariano's scenario is of a Renaissance battle in which various implements of war (war cars, war hammers, catapults) are shown together with guns that did not exist at the time of Vitruvius. Thus, the mechanical designs and indicated solutions are much more like those used in Cesariano's time, although inspiration was clearly achieved through an interpretation of the Vitruvius text.

Barbaro, for his part, chooses not to represent war machines, perhaps because of his religious position.

### 3 Conclusions

In this chapter, machines of the Renaissance time are discussed through interpretations of the works by Vitruvius in Book X of his *De Architectura*, at the same time demonstrating the high level of expertise Vitruvius displayed in machine design.

The above comparative analysis is mainly based on the graphical representation of machines that gives a direct view of the significant mechanical design of Vitruvius's machines, but it also shows the considerable interpretation that the authors of the time worked out as a result of their direct machine expertise and/or current machine technology of their time.

### References

- Barbaro D (1584) *I dieci libri dell'architettura di M. Vitruuio, tradotti, & commentati da monsig. Daniel Barbaro Patriarca d'Aquileia, da lui riuaduti, & ampliati; et hora in più commoda forma ridotti*, Venezia
- Ceccarelli M (2004) Evolution of TMM (theory of machines and mechanisms) to MMS (machine and mechanism science): an illustration survey. Keynote lecture, 11th IFToMM World Congress in mechanism and machine science, vol 1, pp 13–24, Tianjin, China
- Ceccarelli M, De Paolis (2008) A brief account on Roman machines and cultural frames. In: Proceedings of HMM2008-the third IFToMM international symposium on history of machines and mechanisms. Springer, Dordrecht, pp 83–100. ISBN 978-1-4020-9484-2
- Cesariano C (1521) *Di Lucio Vitruuio Pollione De architectura libri dece: traducti de latino in vulgare, affigurati, comentati, & con mirando ordine insigniti: per il quale facilmente potrai trouare la multitudine de li abstrusi & reconditi vocabuli a li soi loci & in epsa tabula con summo studio expositi & enucleati ad immensa utilitate de ciascuno studioso & beniuolo di epsa opera*, Como
- Cigola M, Ceccarelli M (2014) Marcus Vitruvius Pollio (Second Half of the 1st Century B.C.). In: Distinguished figures in mechanism and machine science—part 3, history of mechanism and machine science, vol 26, pp 307–344
- Durantino Francesco Luci ML (1535) *Vitruuio Pollione Di architettura dal vero esemplare latino nella volgar lingua tradotto: e con le figure a suoi luoghi con mirãdo ordine insignito. Anchora con la tauola alfabetica: nella quale facilmente si potra trouare la moltitudine de vocaboli a suoi luoghi cõ gran diligenza esposti: e dichiarati: mai piu da alcuno altro fin al presente stampato a grande vtilita di ciascuno studioso*, Venezia
- Fra' Giocondo M (1511) *Vitruuius per Iocundum solito castigatior factus cun figuris et tabula et iam legi et intelligi posuit*, Venezia
- Fra' Giocondo M (1513) *Vitruuius iterum et Frontinus a Iocundo revisi repurgatique quantum ex collazione liquit, Hoc opus præcipua diligentia castigatum & cura summa excusum est Floretiaë sumptibus Philippi de Giunta Florentini anno domini M.D.XIII. mense Octobri*, Firenze
- Galiani B (1790) *L'architettura di Marco Vitruvio Pollione tradotta e comentata dal marchese Bernardo Galiani Accademico ercolanense, e architetto emerito dell'Accademia di S. Luca. Edizione seconda corredata degli stessi rami disegnati, e fatti incidere dal medesimo traduttore*, Siena, Napoli
- Perrault C (1675) *Les dix livres d'architecture de Vitruve, corrigez et traduits nouvellemnt en francois, avec des notes & des figures*, Paris

- Ryff WH (1575) *Zehen Bücher von der Architectur und künstlichem Bawen. Ein Schlüssel vnd einleytung aller Mathematischen vnnnd Mechanischen Künst Scharpffsinniger fleissiger nachtrachtung oder Speculation künstlicher Werck ...; Alles mit schoenen künstlichen Figuren vnnnd Antiquiteten vnd sonderlichen Commentarien ... gezieret vnd erkleret*, Basel
- Viviani Q (1831–1832) *L' architettura di Vitruvio/tradotta in italiano da Quirico Viviani; illustrata con note critiche ed ampliata di aggiunte intorno ad ogni genere di costruzione antica e moderna con tavole in rame per opera del traduttore e dell'ingegnere architetto Vincenzo Tuzzi; voll. 7-8-9*; Udine



# Trompes or Water Bellows. A Way of Producing Wind Through the Fall of Water

Umberto Meneghetti

**Abstract** Compressed air is nowadays widely used in various industrial applications. In ancient times, it was used both for feeding fires and for wind instruments. Bellows were the usual means, such as piston bellows and leather bellows. In the European Middle Ages and the Renaissance, the progress of metallurgy required the use of large and expensive leather bellows. Some centuries ago, an ingenious and cheaper way of producing compressed air also came into use, namely water bellows or trompes. In Italy, France, Spain and other countries, these were employed for blowing forges, blast furnaces, pipe organs and recreational wind instruments. A trompe works through the action of a column of water falling through a vertical tube. The water enters the pipe mixed with air, which is carried along with the stream through the tube. In an appropriate recipient, the water runs on a hard stone to free the air it carries. From the receiver, the air is conveyed to the utilizing device in a continuous blast. This technology became obsolete with the advent of steam engines. However, for a number of centuries, water bellows represented an important means for producing compressed air and a useful aid for industrial development.

## 1 Introduction

Compressed air is widely used nowadays in various industrial applications. In ancient times, it was used both for feeding forges and furnaces and for recreational purposes. Bellows were the usual means to blow up air to feed fires and for many other purposes. Various types of bellows were used, such as piston bellows and leather bellows.

---

U. Meneghetti (✉)

Department of Industrial Engineering, University of Bologna, Bologna, Italy  
e-mail: umberto.meneghetti@unibo.it

In the European Middle Ages and the Renaissance, the progress of metallurgy demanded the use of large leather bellows driven by means of hydraulic wheels and camshafts, and progress itself was possible due to the development of these devices.

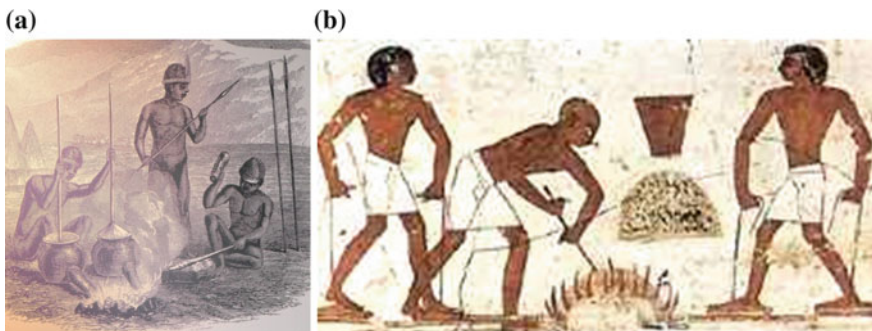
A few centuries ago, a different and ingenious way of producing compressed air also came into use, namely the “water bellows”, or “trompes”, called “trombe idroeoliche” in Italy. These were employed in forges, blast furnaces, pipe organs and recreational wind instruments. This technology became obsolete with the advent of steam engines, so its use now seems rather odd and almost incredible. However, for several centuries, trompes were an important device for obtaining compressed air and a useful support for industrial development.

## 2 Primitive and Ancient Bellows

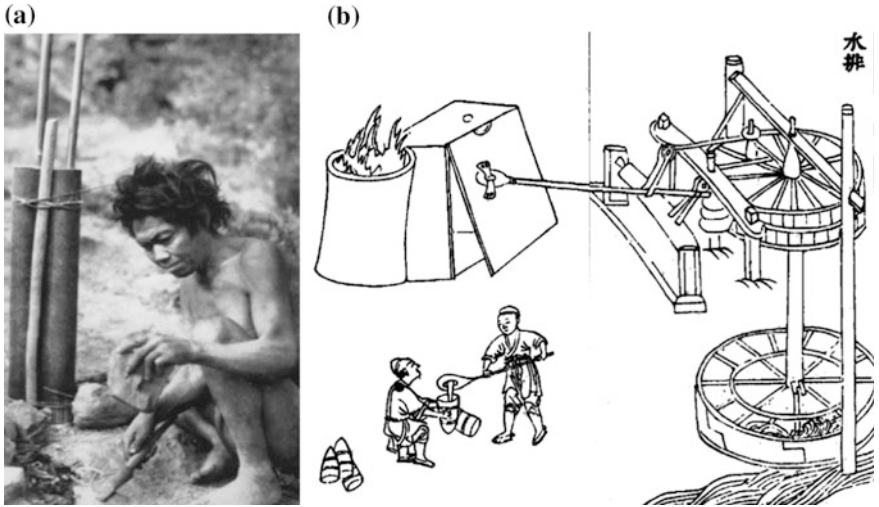
Ignoring very elementary blowing means like hand fans, we can mention the gradually developing primitive and ancient bellows: leather bag blowers (Fig. 1), two-pipes blowers (Fig. 2a), and Chinese wood blowers (Fig. 2b; Wang 1313).

All these primitive blowers, except perhaps the Chinese ones, were unable to blow a large amount of highly pressurized air, so they represented a limitation for the development of metallurgy; or, in other words, they were enough only for a rather primitive metallurgy.

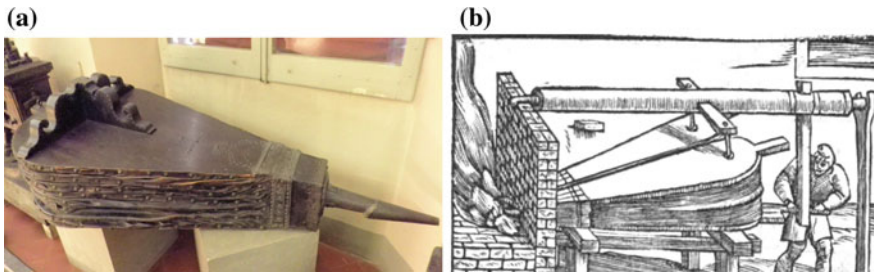
In the European Middle Ages, leather bellows (Fig. 3a) came into use, at the beginning driven by hand (see Fig. 3b) (Biringuccio 1540). Later, especially during the Renaissance, the progress of metallurgy required the use of large bellows driven by means of hydraulic wheels and a camshaft (see Fig. 4), and progress itself was possible due to the development of these devices, which were still in use at the dawn of the 19th Century (Fig. 4; Nicolis di Robilant 1790).



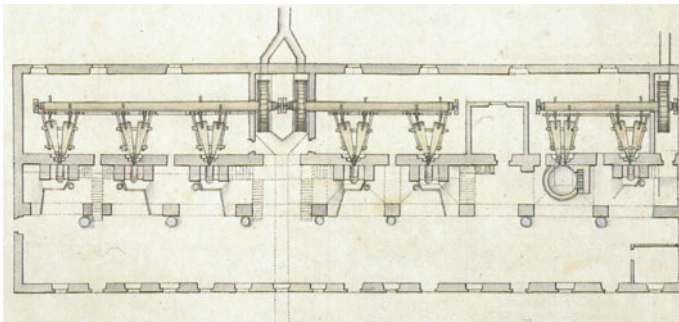
**Fig. 1** a Pigorini Museum, Rome. Sub-Saharan Africa, primitive bellows for an iron furnace, 6th century B.C. b Egyptian bellows for a copper furnace. Detail from a 15th century fresco illustrating the operation of melting a bronze door



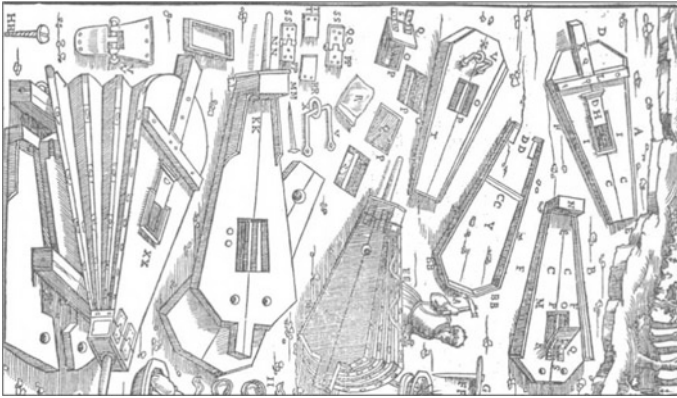
**Fig. 2** a Primitive two-pipe blowers, Southeast Asia. b Chinese wood blowers driven by a hydraulic wheel (Wang 1313)



**Fig. 3** a Davia-Bargellini Museum, Bologna, Italy: Leather bellows, 18th century. b Leather bellows operated by hand (Biringuccio 1540)



**Fig. 4** Set of bellows driven by a hydraulic wheel and a camshaft in a silver foundry, Halsbrück in Freyberg, Sachsen (Nicolis di Robilant 1790)



**Fig. 5** Leather bellows manufacturing in a picture by Agricola (1563)

Leather bellows were complex devices, as clearly inferable from the well-known picture shown in “*De re metallica*” by Agricola (1563) (see Fig. 5). As a consequence, they were very expensive, due to the difficulties encountered in their manufacturing, and also as a result of the cost of the leather, whose life was rather short. Wooden bellows were sometimes used as alternative means, even if they were less efficient than leather bellows.

An alternative device was the “argagno” used in Cecina, Tuscany, throughout the 18th century. In (Lenormand 1840), it is described by these words: “Cecina’s blast furnace is revived partly by two trompes and partly by a hydraulic blowing-machine called an argagno. It consists of two masonry vessels.” Each vessel fills and empties alternatively: when the water enters a vessel, the air is compressed and sent to the furnace; when the water is discharged, the air fills the vessel again. The volume of each vessel was  $17.20 \text{ m}^3$ ; each vessel fills and empties every 48s, but due to the dead volume, the total air produced is only  $25.36 \text{ m}^3/\text{min}$ .

Although efficient and cheap with regard to construction and maintenance, the argagno seems to have had no other applications except for this one in Cecina. Contrastingly, trompes were widely used over several centuries.

### 3 Origin of Trompes

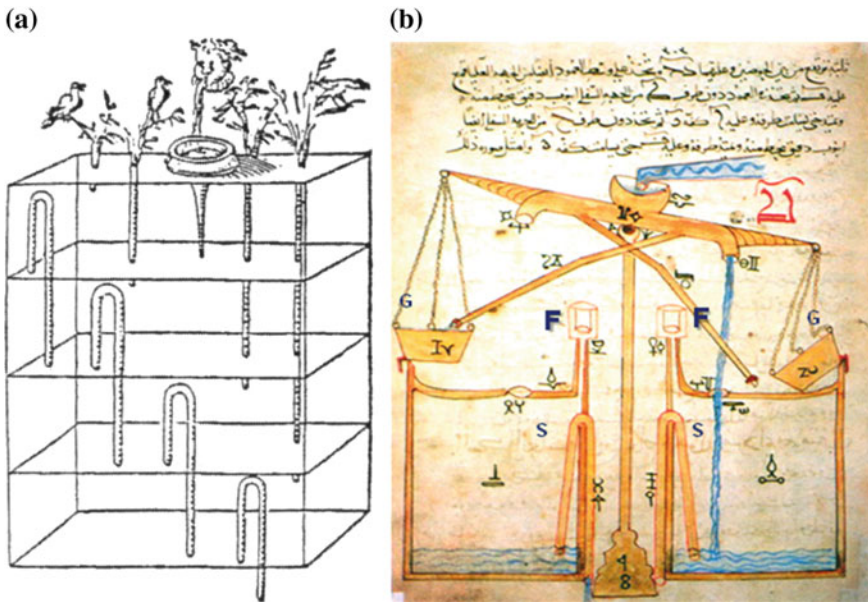
As written in Rees (1819), a trompe is “A machine used to blow air into a furnace, by the action of a column of water falling through a vertical tube. The orifice where the water enters the tube is so contrived, that the water shall be mixed with air when it enters the pipe; and this air will be carried along with the stream through the tube, and is collected into an appropriate recipient, from which it is conveyed to the furnace in a continued blast.”

When and where trompes were born is unknown. In fact, contemporary publications about them are very scarce, probably due to the limited consideration of “mechanics” by the official culture, especially before the Age of Enlightenment.

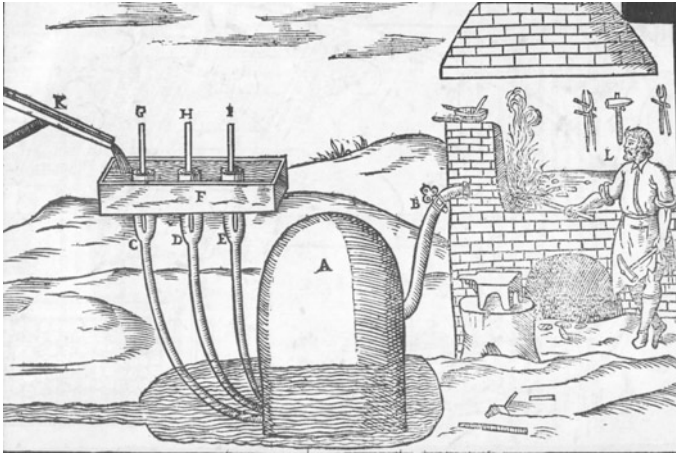
A possible ancestor may be the famous siphon chambers designed by Hero of Alexandria (1575); Aleotti 1589. In the example in Fig. 6a), water is sent to the first chamber, whose air operates the whistler of the first bird; when this chamber is filled, the siphon empties it, sending water into the second chamber whose air operates the second bird; and so on. A substantially similar process was suggested by Al-Jazari (1206) to operate two flutes alternatively (see Fig. 6b). In these devices, the siphon is fundamental, also widely used by many other mechanics and hydraulicians, like, e.g., Aleotti (1589), Salomon de Caus (1615).

Contrastingly, trompes do not use siphons, operating under a very different principle, so they could only have been indirectly inspired by the preceding devices on the basis of an independent observation of their behavior. In fact, the water which enters a chamber drags some air in, which, at least partially, is then freed.

The first written reference to trompes as a means for obtaining compressed air seems to be the one by G. Fontana (c. 1395–1454) (Battisti and Saccaro Battisti 1984), which claims the invention of this device for blowing air into a pipe organ. It



**Fig. 6** a Hero’s blower device with four superimposed siphon chambers (Aleotti 1589). b Al-Jazari’s device with two chambers for feeding air to the flutes F. Floating vessels G shift the feeding water from one chamber to the other. The chambers empty out automatically through the siphons S. In the figure, the chamber on the right is being filled and is blowing air into the flute, while the other chamber is already empty (Al-Jazari 1206)



**Fig. 7** Blowing machine for a forge (“Spiritale per mantice di fucina”) (Branca 1629)

is possible that he was the first to use trompes to feed an organ, but surely trompes were already used in forges. Therefore, the introduction of trompes into Italy before Fontana, i.e., during the 15th or the end of the 14th Century, seems likely, although this has not yet been demonstrated for certain.

An interesting hint regarding trompes can be found in della Porta (1589), who, in 1589, wrote: “I saw in Rome how water can work as a blower. You create a small, and well-sealed room; a lot of water enters through a funnel-shaped duct. An impetuous air stream will rush through an upper orifice as if from a blower and can revive forges and furnaces for iron or copper very well.” Perhaps della Porta did not understand how trompes actually work, but he confirms that, in the 16th century, they were already common devices in Middle Italy.

The pictures in the book “Le Machine” by Branca (1629) are very important from a historical point of view. As an artist, he leaves much to be desired, and his book includes certain misunderstandings, but from his drawings, we can infer that, in 1629, trompes were used both in forges (Fig. 7) and wind instruments (Fig. 8). It should be noted that Branca does not ascribe to himself the invention of the machines he describes, which we must therefore consider to have been already known before him. Going into details of Branca’s drawings, he mistakes water input as coming from the bottom instead of the top and he depicts the lower part of the vessel in an absurd water puddle; however, these misunderstandings do not obscure the historical value of his evidence. With regard to the rods marked G, H, and I in Fig. 8, they are usually interpreted as bungs, in fact, it seems improbable that they could be hollow: in this case, the feeding would be the same as in the Trompes du Pays de Foix (see later), but this method does not appear elsewhere in the literature before the 18th century.

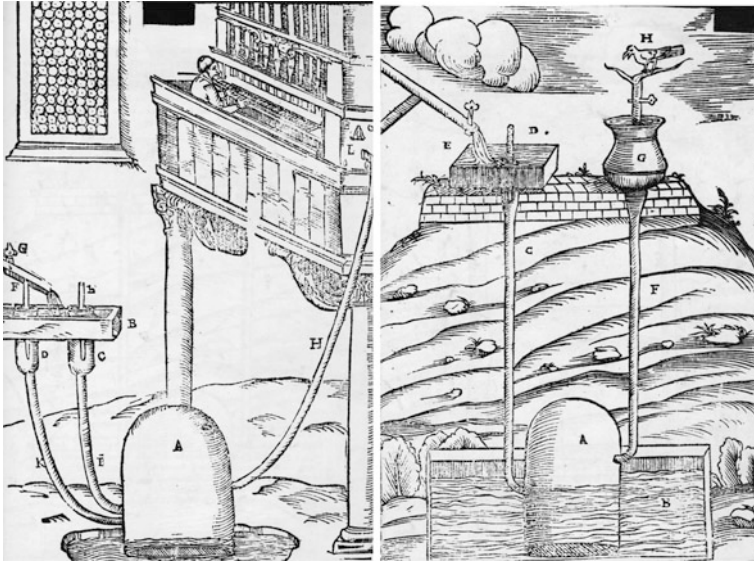
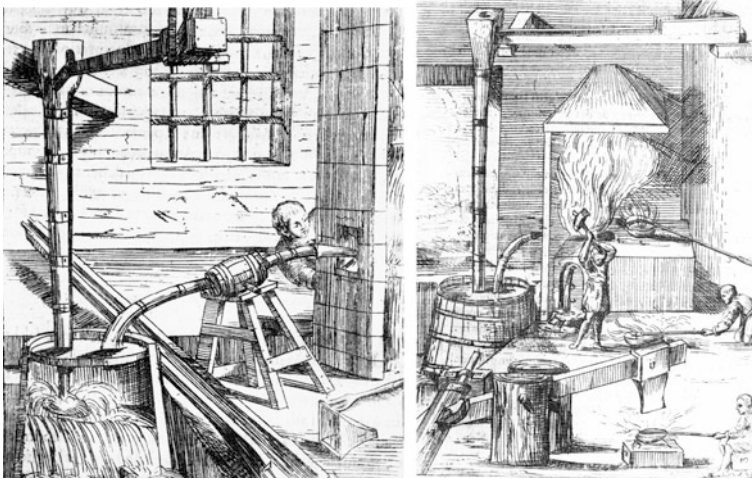


Fig. 8 Trompes feeding a pipe organ (*left*) and a wind automaton (*right*) (Branca 1629)

#### 4 The Technique of Trompes

Comparatively speaking, there are not many contemporary publications about water bellows, due to the limited consideration for “mechanics” by the official culture, especially before the Age of Enlightenment. In Europe, water bellows were probably better known due to their application in pipe organs than for their industrial applications. Compressed air obtained through water bellows was also employed to play automatic musical wind instruments. These were much appreciated as ornaments in luxurious gardens of villas and palaces.

The first treatise which describes trompes from a technical point of view is *Pratica Minerale* (Mining Practice) by della Fratta et Montalbano (1584), a handbook on mines and metallurgy. Trompes are accurately described in five pages of text and in two clear figures (see Fig. 9). Della Fratta explains that trompes need a drop of at least five meters and gives detailed directions about dimensions, type of wood, and so on. The pipe which constitutes the actual trompe is made up of two halves of a hollowed trunk which are then put together. Water must run on a hard stone at the bottom of the vessel to free the air it carries. The vessel has to be suitable to bear the pressure of the air. The bottom of the vessel must be sealed, but a hole allows the water to flow out into an open container or tank, made in such a way that the hole is always below the surface of the water. With regard to the problem of the humidity of the air, he suggests a small butt for collecting the water in the pipe from the vessel and the furnace (see Fig. 9, left).



**Fig. 9** Trompe for a blast furnace with small butt for draining the moisture (*left*); Trompe for a forge (*right*) (della Fratta et Montalbano 1584)

The economic considerations are of particular interest. Della Fratta writes that the usual leather bellows cost 500 scudi, while a trompe cost just 25 scudi. Maintenance is cheaper too, so, when possible, trompes appear the best choice.

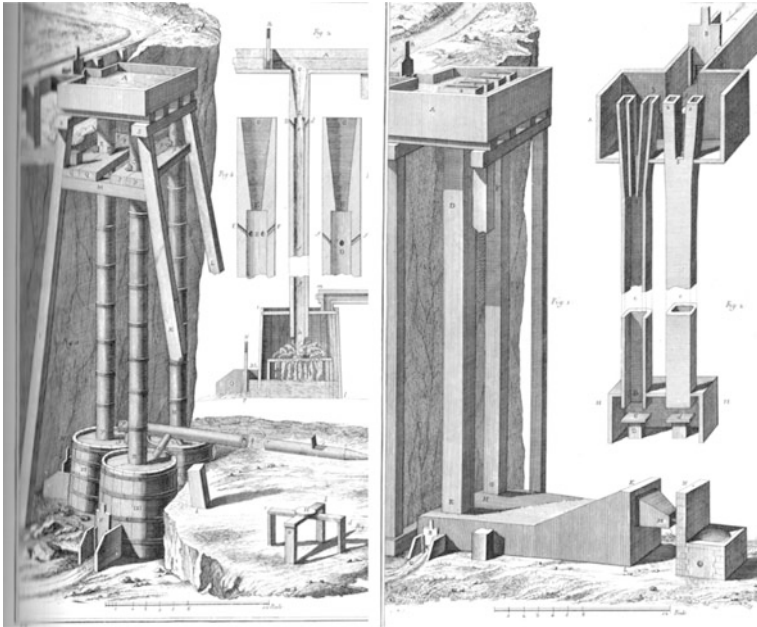
No mention is made of the water and air flow, nor is an explanation given as to how trompes work. Since no measurement is taken to help the air dragging, these trompes are the emulsion type: only a relatively small quantity of air is dragged by the water at the inlet. The same mechanism is also applied in trompes used for feeding pipe organs and other musical wind instruments, which will be briefly discussed in the next section.

Due to the main drawback of the trompes, i.e. in the moisture in the air, their use was limited to countries where the ore's properties made it possible to use the air even if it was humid. In these countries, important improvements were introduced to increase the amount of air in the water flow.

Progress was achieved by putting the water flow in communication with the atmosphere: in accordance with Bernoulli's principle, the pressure in the flow is less than that in the atmosphere, so the air is drawn in. In this way, the transport of air is no longer in emulsion with water, but an air-water two-phase flow with entrained air bubbles is established. Through this mechanism, the amount of conveyed air is greatly increased and the efficiency of the device is improved.

There were two methods for putting the atmospheric air in contact with the water flow. The first was making holes in the vertical pipe which constitutes the trompe itself. The second is a funnel-shaped inlet, with the smallest section in communication with the atmosphere; this can be accomplished in two different ways, i.e., the



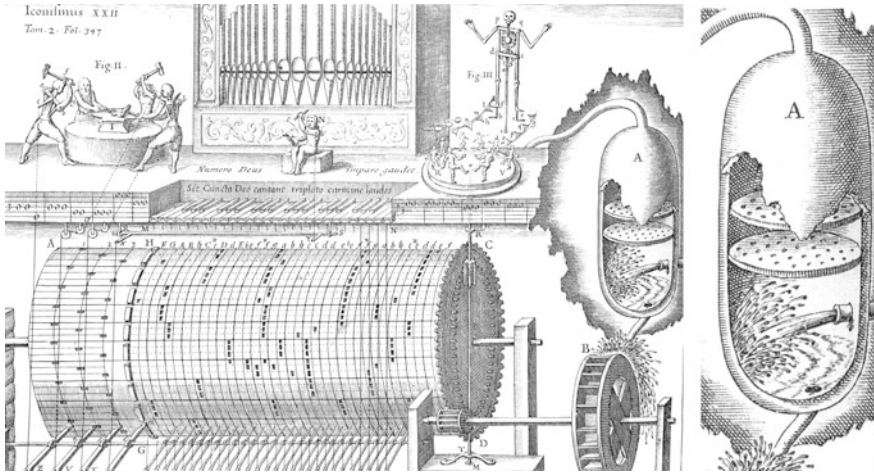


**Fig. 10** Trompes du Dauphiné (*left*) and Trompes du Pays de Foix (*right*) (Diderot and Le Rond d’Alembert 1751)

above-mentioned “Trompes du Pays de Foix” and “Trompes du Dauphiné” methods, as illustrated in Fig. 10 (Diderot and Le Rond d’Alembert 1751). These pictures are so clear and so universally known that, in the 19th century, they were considered the first and only documentation of trompes, and the trompes themselves were believed to have been invented in France.

As an example of the importance of the improvements, in Mongiana (Calabria, South Italy)<sup>1</sup>, in the first years of the 19th century, it turned out that the old trompes were not enough for blowing the required amount of air into the furnaces and were replaced by new trompes, which carried much more air with the same flow of water (De Stefano and Maticena 1979). It is very likely that the “new trompes” were of the types illustrated in Fig. 10. Later, towards the middle of the century, there were thirty-two trompes in Mongiana, fed by two 11.50 m waterfalls, consuming up to 1.25 m<sup>3</sup>/s of water.

<sup>1</sup>Memoria sullo stabilimento di Mongiana fatta dal Cap. Settimo per ordine del Sig. Maggiore Sappel Comandante l’Artiglieria in Calabria. Biblioteca Nazionale di Napoli. Sez. Manoscritti Ms. 63/1.



**Fig. 11** Pipe organ fed by a water bellows, from Kircher's "Musurgia Universalis" (Kircher 1650)

## 5 Pipe Organs and Wind Instruments

As stated above, the first written reference to trompes as a means of obtaining compressed air seems to be the one by G. Fontana, who claims its use for feeding a pipe organ. In fact, this kind of trompe application was very important during the Italian Renaissance. This is testified to by a number of pictures, like those in Figs. 8 and 11, and by the fact that the only ones still in use seem to be the ancient trompes feeding the hydraulic organs at Tivoli near Rome and in the Quirinale Gardens in Rome.

Hydraulic pipe organs were played by a cylinder with protuberances—a sort of camshaft—driven by a hydraulic wheel, while the wind-chest was fed by a trompe (Meneghetti and Maggiore 2011).

The most well-known works on trompes in pipe organs are by Kircher (1650), a German Jesuit who lived in Rome. In Fig. 11 (from Kircher's "Musurgia Universalis"), water enters a chamber A—referred to in Latin as the "Camera Aeolia" by Kircher—and, after having set free the air for the wind-chest, exits and powers the hydraulic wheel to drive the cylinder. The cylinder operates the keys through levers and cords, and also drives simple automata (a forge, a skeleton), intended to entertain the audience, already astonished by the singular "manless" playing instrument.

It should be pointed out that, on the subject of trompes, Kircher wrote: "Habet autem huiusmodi Camerae maximum usum in omni negotio fabrilis, hic enim in Italia passim ferrariis officinis cudenda instrumenta, perpetuum ventum suppeditant", i.e.: "Such chambers are widely used in any forge, actually, in the whole of Italy, they supply continuous wind to workshops for hammering [metals]". These

words testify to the fact that, in Italy during the 17th century, trompes were a usual means for blowing air and that Kircher did not know of their use outside of Italy.

Surely, pipe organs fed by trompes were made only in Italy. In Latanza (1995), seven hydraulic organs are mentioned, from the most ancient—and still working—at Villa d’Este, Tivoli (near Rome), finished in 1569–1570, to the last one at Villa Pamphili in Rome, constructed from 1758–1759. Automatic wind instruments and many waterworks, on the contrary, were common all over Europe. They were much appreciated as ornaments in the luxurious gardens of villas and palaces (Salomon de Caus 1615; Barbieri 1986, 2004). Due to the richness and importance of such clients, many hydraulic technicians and engineers devoted themselves to this kind of apparatus, thus helping technical progress.

## 6 Success and Diffusion of Trompes

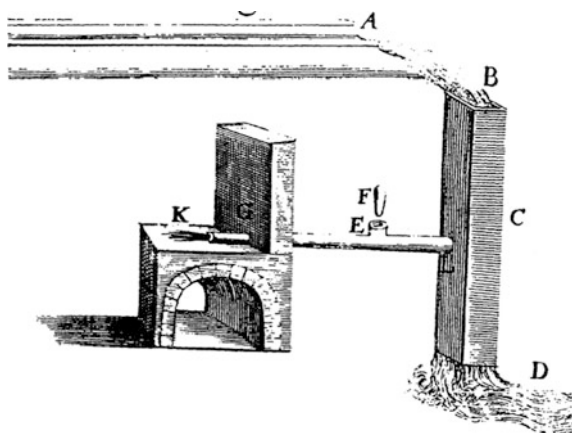
As far as we currently know, the first documentation of trompes is from Italy (Battisti and Saccaro Battisti 1984; Della Porta 1589; Branca 1629) where they had probably been in use for blowing forges and recreational wind instruments since the 15th century. Trompes were common in Italy and France from the 17th up to the 19th centuries in forges and blast furnaces. A traveler, Bartolomeo Soldo, writes in 1608 about trompes for a blast furnace he saw in Valle Sabbia near Brescia, Northern Italy (Marchesi 2004); he expresses his wonder and admiration for this very strange and cheap blowing device, which he calls “stupendous and worth seeing”. Many interesting remnants of trompes can still be found, e.g., in Val Trompia (AA. VV 2010; Fig. 12) and in many other places (Meneghetti 2013).

Around the middle of the 17th century, some publications by A. Kircher about trompes for pipe organs were issued in Italy, see, e.g., (Kircher 1650). In a short time, Kircher’s works, which were written in the erudite language of that period, i.e. Latin, became known all over Europe. As a consequence, trompes became more familiar to musicologists than to engineers and metallurgists. In particular, Schott in

**Fig. 12** The blast furnace at Tavernole (Valtrompia, Northern Italy): entrance of trompes. The rest of the installation is lost



**Fig. 13** Pictures illustrating *W Pope's* "A Way of Producing Wind by the Fall of Water". *A* is the river, *C* the pipe or trompe. Closing the hole *E* with *F*, air blows into the forge. The trompe's representation is very rough (Pope 1665)



Latin (Schott 1657) and Leupold in German (1724) reproduced Kircher's drawings of the "Camera Aeolia" in their books and acknowledged his priority on this subject.

In England, the first written evidence regarding trompes seems to be a letter by "the Learned Doctor Walter Pope, to Reverend Dean of Rippon, the Doctor John Wilkins, Concerning ... And a Way of Producing Wind by the Fall of Water" (Pope 1665), in which Dr. Pope describes "the contrivance of blowing the Fire in the Brassworks of Tivoli near Rome (it being new to me) where the Water blows the Fire, not by moving the Bellows, (which is common) but by affording the Wind" (see Fig. 13). In a subsequent description of the device, Pope does not try to explain how a "vehement wind" is obtained.

Pope's letter was published in "Philosophical Transactions" in 1665. A year later, it was translated into French and published in the "Journal des Sçavans" (later "Journal des Savants") (Le Journal des Sçavans 1666); these seem to be the first reports about trompes in France. In 1775, Grignon (1775) wrote that trompes were invented in Italy around 1640, probably deducing this from Pope's letter. He distinguished four kinds of trompes in France, three of them used for blowing furnaces in different places (Comté de Foix, Dauphiné, Pyrennés) and the fourth used in mines as fans. Grignon also reported that a trompe of the fourth type was in use in a copper furnace at Cassel (now Kassel), Germany.

In Spain, there were written reports on trompes before those that appeared in England and France. In (1632), P.A. de Rivadeneira—a miner in Peru—was granted a patent for "a device for blowing furnaces without bellows already used in Genoa", i.e., trompes. Some years later, in 1641, the negative outcome of these devices was observed, in fact, "they produced less iron and used more coal", despite the fact that "they were successfully used in Genoa" (Almunia and de León 1951; Beck 1903). We do not know if this failure was due to poor construction of the trompes or—more probably—to the different nature of the ore with respect to that found in Genoa.

In Germany, Schott (1657) made Kircher's "Camera Aeolia" known in 1658, but Beck (1903) reported that, as of 1702, in Ritterplatz, the trompe ("Wassertrommel") was still described as an odd device seen at copper mines (?) near Rome: "bey Rom in dem Tiburtinischen Kupffer-Bergwerke ist ein cureuses Gebläse zu sehen und nimt mich nicht wenig Wunder, dass fast nicht in einer einigen Italiänischen Reise-Beschreibung davon gedacht wird." In 1724, Leupold (1724) described "a new invention of which they make use for blowing the fire in copper forges at Tivoli near Rome". The famous Swedish metallurgist Swedenborg (1734) wrote about trompes in blast furnaces in 1734; he ascribed their invention to Italians, but discouraged their use due to the humidity in the air.

In 1910, i.e., when elsewhere trompes had been practically abandoned, the biggest trompe ever made in the entire world was built in Canada.<sup>2</sup> It transmitted air-power to the mining industry in the area of Ragged Chute, in Northern Ontario.

## 7 Engineering Analysis

Trompes were never closely investigated with an engineering approach. In his handbook on mines and metallurgy, della Fratta et Montalbano (1584) describes a specific type of trompe, giving instructions about many technical details, but not explaining how trompes work. Others did the same, e.g., Kircher (1650). In fact, trompes appeared before Hydraulics became a science, and this was clearly an obstacle to their progress and improvement. It suffices to say that, as late as 1791, the Academy of Toulouse, France "invited philosophers to determine the cause and nature of the stream of air produced in these machines" (Rees 1819): this shows how difficult it was to interpret the operation of trompes.

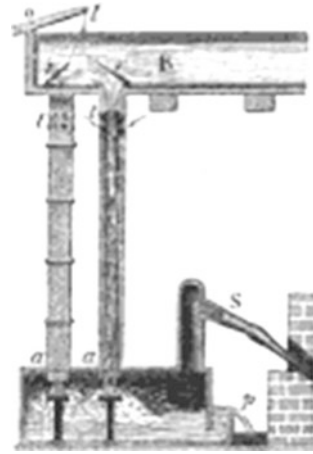
Improvements between early and later trompes essentially lie in the exploitation of Bernoulli's principle, which involved the change from trompes of emulsion to the more efficient trompes with an air-water two-phase flow. Bernoulli's principle was published in 1738, but did not become generally known until many years later, so the progress of trompes was probably due to an ignorant use of this principle, or rather, was the successful result of a sensible but empirical attempt to obtain more air.

A description of a trompe's functioning on the basis of scientific principles can be found, e.g., in Rees (1819), Daguin (1861) (Fig. 14), but no formulas for the numerical handling of the problem are given. This could be due to the fact that scientific means for handling the question became available when trompes were rather out-of-date in comparison with devices driven by steam engines. Actually, trompes remained in use up to the middle of the 20th Century, but in ever less

---

<sup>2</sup><http://www.sudburyminingsolutions.com/category/technology>. (Search for: Prof aims to revive Ragged Chute technology).

**Fig. 14** Picture from *Daguin*, “*Traité élémentaire de Physique théorique et expérimentale*” which explains the air transportation through Bernoulli’s principle (Daguin 1861)



important and secondary plants, so a modern engineering approach was neither required nor justified for these marginal devices.

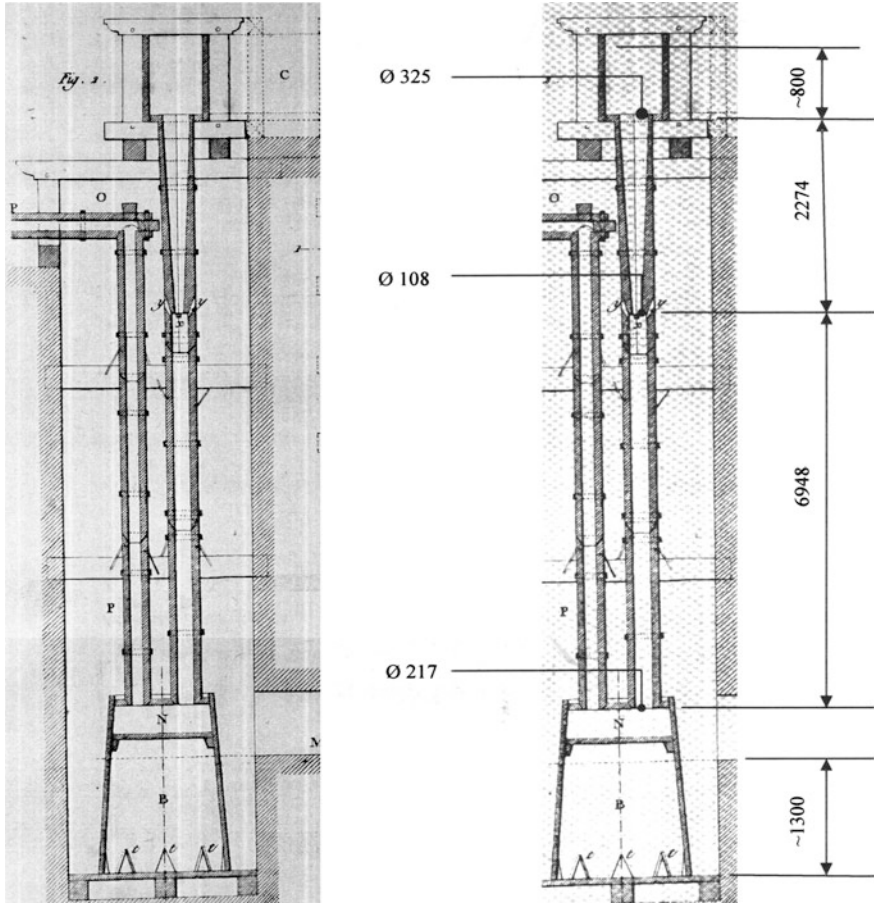
Proof of the importance and diffusion that trompes had up until the beginning of the 19th century can be found in the experimental researches carried out in 1804 by two mining engineers, Beaunier and Gallois (1804). Their work regarded a trompe used in the foundry of Pollaouen in Brittany, France. This was a large plant, with two identical trompes running in parallel. The upper part of each trompe, about 2.2 m long, was tapered. At the end of this part, there were four inlets for letting in the air, which was then dragged by the water along the cylindrical part of the trompe about 7 m long (see Fig. 15). The diameter of the cylindrical part was the mean measurement between the maximum and minimum diameters of the tapered part.

Before describing their experiences, the two engineers summarized the results obtained by another researcher, who found that the air could be brought into the water efficiently both from top or side slots, but the two means were not to be used together, because, in this case, they weakened each other.

In their work, Beaunier and Gallois utilized the instruments available at that time: a device called an *anemomètre à eau* for measuring the air pressure and special cork floats for measuring the water’s speed in the upper feeding duct. From the speed, they deduced the water flow.

The most interesting results regarded the pressure and flow of air and water consumption. Air pressure in the lower chamber was between 700 and 800 mm water; air flow was about 15 Sm<sup>3</sup>/min; water flow was about 6 m<sup>3</sup>/min. The efficiency was, therefore, about 2.5 Sm<sup>3</sup> of air for one m<sup>3</sup> of water. Comparing this efficiency with that of bellows driven by means of hydraulic wheels and a camshaft, trompes were much more efficient and really advantageous. We may infer that trompes’ limitation was not their efficiency, nor was it their cost, but—most likely—their need for a waterfall and air humidity.

Some decades later, of course, steam engines slowly made trompes obsolete.



**Fig. 15** Detail of the water bellows illustrating the paper “Expériences faites sur les trompes de la Fonderie de Poullaouen” [Beauvier, Gallois]. Dimensions are in mm

## 8 Conclusions

Compressed air is essential in metallurgy for feeding forges and furnaces. In ancient times, bellows were used for obtaining compressed air, used both in metallurgical industries and to operate pipe organs and certain recreational wind instruments.

Some centuries ago, a different and cheaper way also came into use, namely the *water bellows* or *trompes*. It seems that they appeared for the first time in Italy (Boni 1958) and then spread to many European countries, especially France, from the 17th to the 19th centuries A.D.

Trompes became obsolete with the advent of steam engines. However, for a few centuries, they represented an important means for producing compressed air and

provided a significant contribution to industrial development. They are an interesting example of human ingenuity in exploiting natural resources for improving mankind's condition.

## References

- AA. VV (2010) *La via del ferro e delle miniere in Valtrompia*. Comunità Montana di Valle Trompia. ISBN: 9788895878027
- Agricola G (1563) *De Re Metallica*. In: Basilea per Hieronimo Frobenio
- Aleotti GB (1589) *Gli artificiose et curiosi moti spirituali di Herrone*, tradotti da m. Gio. Battista Aleotti d'Argenta. Aggiuntovi dal medesimo Quattro Theoremi non men belli, & curiosi de' gli altrj. Et il modo con che si fà artificiosamente salir un Canale d'Acqua viva ò morta in cima d'ogn'alta Torre. In Ferrara, Vittorio Baldini
- Al-Jazari IR (1206) *The book of knowledge of ingenious mechanical devices*. Donald Routledge Hill Ed., Dordrecht (1974)
- Almunia J, de León J (1951) *Notas para una historia de la siderurgia española. El ingenio para fundir sin fuelles de Pablo Antonio de Rivadeneira*. Revista del Instituto del Hierro y del Acero
- Beaunier et Gallois (1804) *Expériences faites sur les Trompes de la Fonderie de Poullaouen*. Journal des Mines, an XII N 91, Germinal an 12:37–48
- Beck L (1903) *Die Geschichte des Eisens*. F. Vieweg u. Sohn
- Barbieri P (1986) *Organi e automi musicali idraulici di Villa d'Este a Tivoli*. L'Organo, XXIV: 3–61 (Pàtron Editore, 1990)
- Barbieri P (2004) *Ancora sulla Fontana dell'organo di Tivoli e altri automatismi sonori degli Este (1576–1619)*. L'Organo, XXXVII (Pàtron Editore, 2005)
- Battisti E, Saccaro Battisti G (1984) *Le Macchine Cifrate di Giovanni Fontana*. Arcadia Edizioni, Milano
- Boni B (1958) *Sull'origine italiana delle trombe idroeoliche*. La fonderia italiana 5:161–168
- Branca G (1629) *Le Machine*, Roma, per Iacomo Mascardi
- Biringuccio V (1540) *De La Pirotechnia*
- Daguin PA (1861) *Traité elementaire de Physique théorique et expérimentale avec les applications à la Météorologie et aux Arts Industriels*. Toulouse, E. Privat – Paris, Dezobry et Magdeleine della Fratta et Montalbano MA (1584) *Pratica Minerale*. All'Insegna del Giglio, Firenze, 1985, anastatic reprint of Manolesi edition, Bologna 1678, M Cima Editor
- De Stefano Manno B, Matacena G (1979) *Le Reali Ferriere ed Officine di Mongiana*. Napoli, Storia di Napoli e della Sicilia
- Della Porta GB (1589) *Della Magia Naturale Libri XX*, appresso Antonio Bulifon, Edizione 1677
- Diderot D, Le Rond d'Alembert JB (1751–1772) *Encyclopédie, ou Dictionnaire Raisonné des Sciences, des Arts et des Métiers*
- Grignon P-C (1775) *Memoires de Physique sur l'art de fabriquer le fer*. Delalain, Paris
- Hero of Alexandria (I sec. d. C.?) (1575) *Heronis Alexandrini spiritualium liber a Federico Commandino Urbinat ex Graeco nuper in Latinum conversus*, Urbini
- Kircher ASJ (1650) *Musurgia Universalis*
- Latanza A (1995) *Il ripristino dell'organo idraulico del Quirinale*. Istituto Poligrafico e Zecca dello Stato. ISBN: 8824039332
- Le Journal des Sçavans (1666) *Extrait du journal d'Angleterre, Touchant une Mine de Mercure qui est dans le Frioul & la maniere de faire du vent par la chute de l'eau*, pp 169–172
- Lenormand M (1840) *Nuovo Dizionario universale tecnologico o di arti e mestieri e della economia industriale e commerciale compilato dai signori Lenormand etc.*, vol 25 B (Google eBook)



- Leupold J (1724) *Theatrum Machinarum Generale. Schau-platz Des Grundes Mechanischer Wissenschaften*. Leipzig, Christoph Zunckel
- Marchesi G (2004) *Cosa stupenda et degna d'essere veduta: la tromba idroeolica in Valle Sabbia agli inizi del Seicento*. Brescia, Officina delle Idee
- Meneghetti U (2013) *Trombe idroeoliche*. VI Giornata di Studio "Ettore Funaioli", pp 41–60. ISBN: 9788874886159
- Meneghetti U, Maggiore A (2011) *Antique and Old Applications of Cam Mechanisms*. 13th World Congress in Mechanism and Machine Science, Guanajuato, México, IMD-123
- Nicolis di Robilant SB (1790) *Viaggi Mineralogici*, a cura di V Garuzzo, Leo S. Olschki, 2001
- Pope W (1665–1666) *Concerning the mines of Mercury in Friuli; and a way of producing wind by the fall of water*. *Phil Trans* 21–26
- Registro y relation general de minas de la corona de Castilla – Segunda y tercera parte (1632)
- Rees A (1819) *The cyclopædia or universal dictionary of arts, sciences, and literature*, vol XXXVIII. Longman, Hurst, Rees, Orme and Brown, London
- Salomon de Caus (1615) *Les raisons del forces mouvantes*. A Francfort: en la boutique de J. Norton
- Schott GSJ (1657–1658) *Mechanica hydraulico-pneumatica*. Würzburg, Francoforte sul Meno, H. Pigrin
- Swedenborg E (1734) *Opera Philosophica et Mineralia. Regnum Subterraneum sive minerale*. Friedrich Hekel, Leipzig
- Wang Z (1313) *Nong Shu*

# Determination of Torsional Stresses in Shafts: From Physical Analogies to Mathematical Models

Augusto Ajovalasit, Vincenzo Nigrelli, Giuseppe Pitarresi  
and Gabriele Virzì Mariotti

**Abstract** This paper presents the historical development of methods used for the study of torsional stresses in shafts. In particular, the paper covers both analog methods, especially those based on electrical analogies proposed circa 1925, and numerical methods, especially finite difference methods (FDM), finite element methods (FEM) and boundary element methods (BEM).

## 1 Introduction

The evaluation of stresses in shafts subjected to torsion is of fundamental importance in mechanical engineering design. Until about 1960, analog methods were widely used, even if a shift towards numerical methods began to emerge in the 1950s, due to their faster implementation.

Apart from the hydrodynamic analogies (Timoshenko and Goodier 1951, page 292; Den Hartog and Mc Givern 1935; Higgins 1945b), the application of which is essentially qualitative, the following analogies were widely used:

1. the analogy with the elastic membrane (Prandtl 1903; Griffith and Taylor 1917, 1918),
2. the electrical analogies for the study of torsion in shafts of constant cross-section (Biezeno and Koch 1933; Cranz 1933; Manzella 1939),

---

A. Ajovalasit · V. Nigrelli · G. Pitarresi (✉) · G.V. Mariotti  
DICGIM, University of Palermo, viale delle Scienze, Palermo, Italy  
e-mail: giuseppe.pitarresi@unipa.it

A. Ajovalasit  
e-mail: a.ajovalasit@gmail.com

V. Nigrelli  
e-mail: vincenzo.nigrelli@unipa.it

G.V. Mariotti  
e-mail: gabriele.virzimariotti@unipa.it

- the electrical analogies for the study of torsion in axisymmetric shafts (Jacobsen 1925; Thum and Bautz 1934; Giordano 1940a; Manzella 1940a).

Reviews of analogies for the torsion in shafts are given by Higgins (1945a, b). An extensive review of the main analogies in Experimental Solid Mechanics and, in particular, those for studying torsion is given by Hetenyi (1950) in the classic Manual of Experimental Stress Analysis. It is significant that the subsequent editions of Experimental Mechanics of Solids (Kobayashi 1987; Sharpe 2008) no longer feature the chapter on the analogies. In fact, starting in the second half of the 20th century, the development of Computational Mechanics has produced a change in attention from methods based on analog models (such as the analogies for the study of torsion) to those which operate on mathematical models.

This paper presents the evolution of the methods used for the study of torsional stresses in shafts. This historical review was presented at the IFToMM Workshop on the History of Mechanism and Machine Science (Ajovalasit et al. 2013). Specifically, the paper focuses on the evolution from analog methods, in particular, those based on continuous electrical analogies, which use electrolytic tanks or other conductive media, to numerical finite difference methods (FDM), finite element methods (FEM) and boundary element methods (BEM). A more comprehensive analysis is presented in the paper by Ajovalasit et al. (2014).

## 2 Electrical Analogies

### 2.1 *Electrical Analogies for the Analysis of Torsion in Shafts with Constant Cross-Section*

It is well known that torsion in shafts having constant cross-section is governed by the stress function  $\varphi$  that satisfies the Poisson's equation

$$\frac{\partial^2 \varphi}{\partial x^2} + \frac{\partial^2 \varphi}{\partial y^2} = -2G\theta, \quad (1)$$

with the boundary condition  $\varphi = \text{constant}$ , and where  $G$  is the transverse modulus of elasticity and  $\theta$  the unitary angle of torsion.

It is also known that the stress function  $\varphi$  can be expressed as:

$$\varphi = \phi - \frac{1}{2}G\theta(x^2 + y^2), \quad (2)$$

where the warping function  $\phi$  satisfies the Laplace equation, that is:

$$\frac{\partial^2 \phi}{\partial x^2} + \frac{\partial^2 \phi}{\partial y^2} = 0, \quad (3)$$

with the boundary condition  $\phi = \text{variable}$ .

Once the stress function is known, the shear stresses are calculated using the following relations:

$$\tau_{xz} = \frac{\partial \phi}{\partial y}, \quad (4)$$

$$\tau_{yz} = \frac{\partial \phi}{\partial x}. \quad (5)$$

The distribution of the electric potential  $V$  in a continuous conductive medium, homogeneous, isotropic and having constant thickness  $h$ , satisfies the following Poisson's equation:

$$\frac{\partial^2 V}{\partial x^2} + \frac{\partial^2 V}{\partial y^2} = -Ri, \quad (6)$$

being  $R = \rho/h$ , and where  $\rho$  is the resistivity of the conductive medium and  $i$  is the density of current injected through the surface of the conductive medium. In the absence of internal current sources ( $i = 0$ ), the potential  $V$  satisfies the Laplace equation:

$$\frac{\partial^2 V}{\partial x^2} + \frac{\partial^2 V}{\partial y^2} = 0. \quad (7)$$

Therefore, two electrical analogies are applicable, based on the similarity of the following equations:

- analogy based on Poisson's Eqs. (1) and (6);
- analogy based on Laplace's Eqs. (2) and (7).

In both analogies, a conductive medium of constant thickness, having a shape equal to that of the cross section of the shaft under consideration, such as an electrolytic tank or a conductive paper, is used. In the first analogy, based on Poisson's Eqs. (1) and (6), a constant voltage  $V_o$  is applied along the contour, while a uniform electric current  $i$  is injected through the transverse surface.

This analogy was applied by Waner and Soroka (1953) by using the Teledeltos conductive paper. The experimental results agree well with the numerical ones obtained with the relaxation method by Huth (1950).

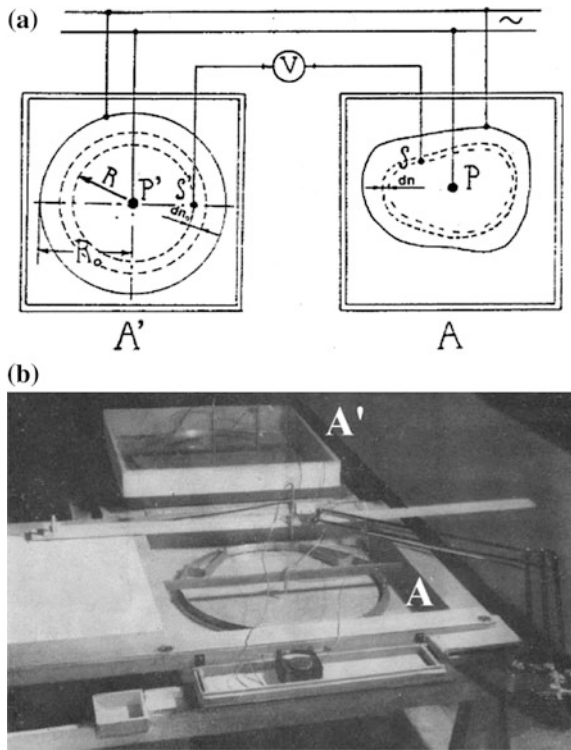
In the second analogy, based on Laplace’s Eqs. (2) and (7), a variable voltage  $V_o$  is applied to the contour, while no electric current is injected through the transverse surface. This second analogy is usually easier to implement because it is easier to achieve a variable distribution of potential along the contour, rather than enter a uniform electric current through the transverse surface. This analogy was applied by Beadle and Conway (1963); in this case too, the Teledeltos conductive paper type was used.

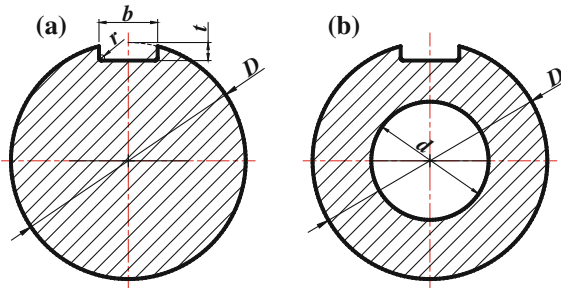
The simplified analogy, proposed by Manzella (1939), is based on the use of two electrolytic tanks (see Fig. 1). In the two tanks, the profile of the shaft to be studied and a reference profile (circular cross section) are immersed in the conductive medium (common drinking water).

Both profiles are subject to an electric voltage difference  $V_o$  between the external boundary and the centre of twist. The drawbacks of the two analogies indicated above are therefore eliminated.

The equipotential lines in the measurement shaft and the reference shaft (circular shape) are first detected. The stress  $\tau$  is then calculated from  $dn$ ,  $dn_o$  (Fig. 1a) and  $\tau_o$ , where  $dn$  and  $dn_o$  are the distances between the corresponding equipotential lines,

**Fig. 1** a Scheme of the electrolytic tanks based on Manzella’s analogy:  $A$  = measurement tank,  $A'$  = reference tank,  $P$ ,  $P'$  = centres of twist,  $S$ ,  $S'$  = measuring and reference probes; b general view of the electrolytic tanks built at the University of Palermo



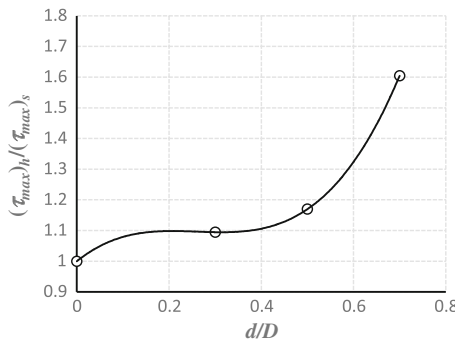


**Fig. 2** Cross-section of a shaft with constant cross section with a parallel keyway: **a** solid section, **b** hollow section

respectively detected in the measurement tank and in the reference tank, and  $\tau_o$  is the reference stress at the radius  $R$  of the circular reference shaft.

The above-mentioned analogy has been applied to several case studies using electrolytic tanks built in 1938 at the Institute of Machine Design of the University of Palermo. In particular, the following applications are cited: shafts, both solid and hollow (Fig. 2), with parallel keyway, tangential keyways and splined shafts (Manzella 1940b).

An example of obtained results is here reported with reference to the case of Fig. 2, which shows a shaft having  $r/D = 0.012$ ,  $b/D = 0.25$  and  $t/D = 0.076$ . The ratio  $(\tau_{max})_h/(\tau_{max})_s$  as a function of the degree of the cavity  $d/D$ , is plotted in Fig. 3, where  $(\tau_{max})_h$  and  $(\tau_{max})_s$  respectively indicate the maximum shear stresses in the hollow shaft and those in the solid one (with the subscripts  $h$  and  $s$  standing for hollow and solid), while  $d$  and  $D$  (Fig. 2) indicate the inner and outer diameters of the hollow shaft. As noted by Manzella, the influence of the *degree of cavity* (ratio  $d/D$ ) becomes significant for degrees of cavity exceeding 0.5.



**Fig. 3** Hollow shaft with a parallel keyway: ratio  $(\tau_{max})_h/(\tau_{max})_s$  as a function of the ratio  $d/D$  between the internal and the external diameters

## 2.2 Electrical Analogies for the Analysis of Torsion in Axisymmetric Shafts

It is well known that torsion in axisymmetric shafts is governed by the stress function  $\phi$  that satisfies the following equation:

$$\frac{\partial}{\partial r} \left( \frac{1}{r^3} \frac{\partial \phi}{\partial r} \right) + \frac{\partial}{\partial Z} \left( \frac{1}{r^3} \frac{\partial \phi}{\partial Z} \right) = 0, \quad (8)$$

where the boundary conditions are:  $\phi = \phi_e$ ,  $\phi = \phi_i$  (constants) at the outer and inner diameters of the shaft and where  $r$  and  $z$  indicate the abscissas, respectively, in the radial direction and along the axis of the shaft. The lines  $\phi = \text{constant}$  are called *shear stress lines*. The lines perpendicular to the *shear stress lines* are called *equiangular lines* and are the locus of points that display the same angle of rotation (Hetényi 1950).

Alternatively, the torsion can be described by the function  $\psi$  (*twist function*) which satisfies the following equation:

$$\frac{\partial}{\partial r} \left( r^3 \frac{\partial \psi}{\partial r} \right) + \frac{\partial}{\partial Z} \left( r^3 \frac{\partial \psi}{\partial Z} \right) = 0. \quad (9)$$

In the formulation of the problem of torsion by using the stress function  $\phi(r, z)$ , the components of the shear stresses are given by

$$\tau_{r\theta} = -\frac{1}{r^2} \frac{\partial \phi}{\partial Z}, \quad (10)$$

$$\tau_{\theta z} = -\frac{1}{r^2} \frac{\partial \phi}{\partial r}, \quad (11)$$

whereas the resulting stress  $\tau$  is given by

$$\tau = \frac{1}{r^2} \frac{\partial \phi}{\partial v}, \quad (12)$$

where the symbol  $v$  indicates the abscissa along the normal to the lines  $\phi = \text{constant}$ .

When the twist function  $\psi$  is used, the shear stresses are given by

$$\tau_{r\theta} = Gr \frac{\partial \psi}{\partial r}, \quad (13)$$

$$\tau_{\theta z} = Gr \frac{\partial \psi}{\partial Z}. \quad (14)$$

In this last case, the resulting shear stress  $\tau$  is given by

$$\tau = Gr \frac{\partial \psi}{\partial v'}, \quad (15)$$

where  $v'$  indicates the abscissa along the normal to the lines  $\psi = \text{constant}$ .

The electrical potential  $V$  in a continuous conductive medium, homogeneous and isotropic of variable thickness  $h$ , satisfies, in the absence of internal current sources, the following differential equations:

$$\frac{\partial}{\partial x} \left( \frac{1}{x^3} \frac{\partial V}{\partial x} \right) + \frac{\partial}{\partial y} \left( \frac{1}{x^3} \frac{\partial V}{\partial y} \right) = 0, \quad (16)$$

$$\frac{\partial}{\partial x} \left( x^3 \frac{\partial V}{\partial x} \right) + \frac{\partial}{\partial y} \left( x^3 \frac{\partial V}{\partial y} \right) = 0, \quad (17)$$

where the thickness  $h$  varies according to the following relationships, valid, respectively, for Eqs. (16) and (17)

$$h = c/x^3, \quad (18)$$

$$h = cx^3. \quad (19)$$

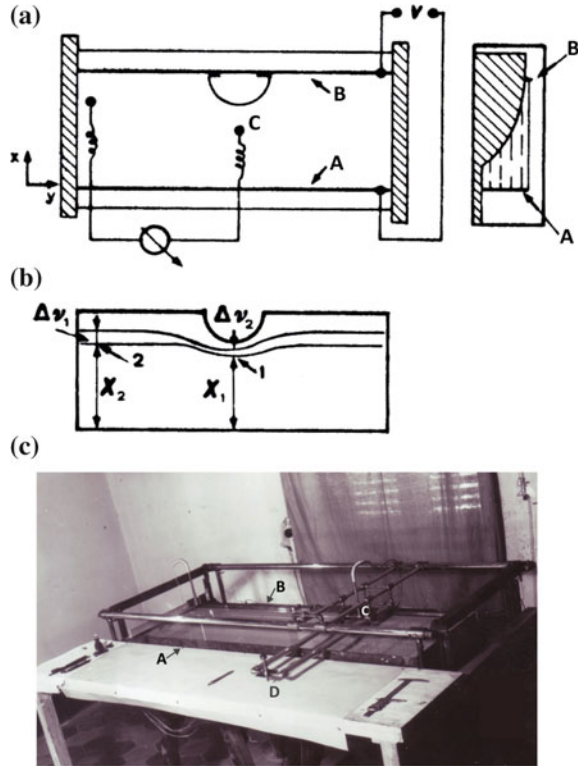
Two electrical analogies are applicable based on the above equations: analogy of Jacobsen based on Eqs. (9) and (17) and analogy of Thum and Bautz based on Eqs. (8) and (16). A comparison between the two analogies can be found in Hetényi (1950) where some of the causes of error in the analogies cited before are discussed.

Stress concentration factors for shouldered shafts, determined by Jacobsen (1925) using his analogy, are reported in the first edition of the classic (Peterson 1953) book on stress concentration factors. In the following, only the second analogy is described. This analogy was first proposed by Thum and Bautz (1934). Figure 4 shows the scheme of the electrolytic tank, based on the analogy by Thum and Bautz. This tank, realized at the University of Palermo in the late '30s (Giordano 1940a), is 150 cm long and 50 cm wide. The long sides (A) and (B) are conductors (copper), while the short sides are in insulating material (pitch-pine). The larger electrode (A) represents the axis of the shaft, while the smaller one (B) is the external boundary of the shaft. This contour can be easily changed using suitable templates; so, for instance, Fig. 4 shows a shaft with a semi-circular groove.

The thickness  $h$  along the transverse direction  $x$  of the tank varies, as mentioned previously, according to Eq. (18), i.e.,  $h = cx^3$ . Near the axis, however, a constant thickness  $h$  is chosen, because it is not possible to achieve  $h = \infty$  for  $x = 0$ . In the tank made at the University of Palermo, the thickness of the conductive medium (common drinking water) varies between  $h = 5$  mm in correspondence of the



**Fig. 4** Electrolytic tank, based on the analogy by Thum and Bautz. **a** Scheme of the tank; **b** tracing of equipotential lines; **c** general view of the electrolytic tank made at the University of Palermo

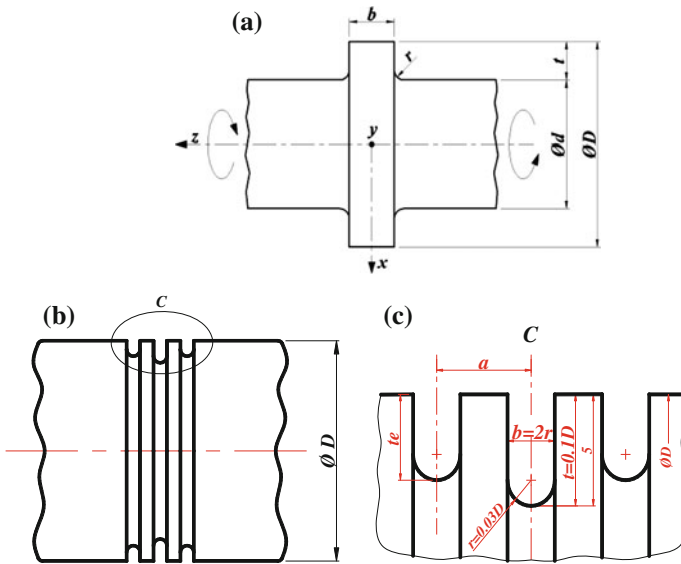


external boundary ( $x = 500$  mm) and  $h = 78.12$  mm between the diameter having abscissa  $x = 200$  mm and the axis ( $x = 0$ ) of the tank.

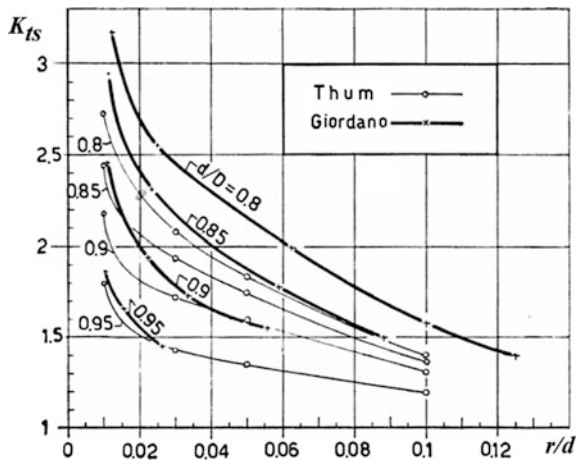
A voltage difference  $V$  is applied between the two electrodes  $A$  and  $B$ ; then, by using a measurement probe ( $C$ ) mounted on a carriage, equipotential lines are determined. Finally, by means of a tracing marker  $D$  (shown in Fig. 4c), connected to the same carriage of the probe, the equipotential lines are traced on a sheet of paper (Fig. 4b, c). From the equipotential lines (Fig. 4b), the four geometric quantities are measured:  $x_1$ ,  $x_2$ ,  $\Delta v_1$ ,  $\Delta v_2$ . This allows for the determination of the stress concentration factors  $K_{ts}$  from which, knowing the nominal stress  $\tau_n$ , the maximum shear stress is derived.

Shafts with various discontinuities have been studied with the above tank by Giordano (1940b, c) and Manzella (1940a). Figure 5 shows some of the geometries studied by these Authors: shaft with collar or with variation in diameter (Fig. 5a), and shaft with multiple grooves (Fig. 5b, c).

Figure 6 shows a comparison between the experimental results obtained by Giordano (1940c) and those obtained by Thum and Bautz (1934), both using the electrical analogy of Thum and Bautz but different electrolytic tanks. As noted by Giordano (who also quotes a correspondence with Thum, cited in Giordano



**Fig. 5** Axisymmetric shafts geometries: **a** shaft with collar or with variation of diameter ( $b/t \rightarrow \infty$ ), **b** shaft with multiple grooves, **c** zoomed representation of the grooves

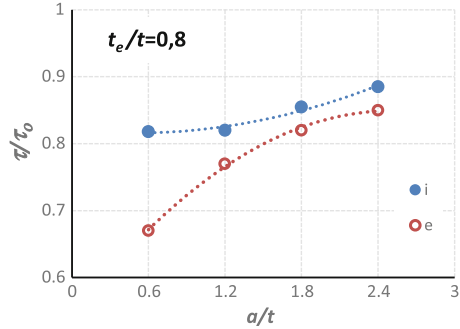


**Fig. 6** Stress concentration factors  $K_{ts} = \tau_{max}/\tau_n$  for shouldered shafts (smaller diameter/larger diameter =  $d/D$ ) subjected to torsion vs the ratio  $r/d$  between the radius of the fillet and the diameter  $d$  of the smaller shaft (based on a figure taken from Giordano 1940c)

(1940c), values resulting from Giordano's experiments are higher, especially for lower values of  $d/D$ .

Figure 7 shows the shielding effect of multiple grooves (Fig. 5b, c) on the stress concentration in axisymmetric shafts.

**Fig. 7** Axisymmetric shaft with three grooves (Fig. 5b, c). Ratio  $\tau/\tau_0$  as a function of the ratio  $a/t$  ( $e$  = external groove,  $i$  = internal groove)



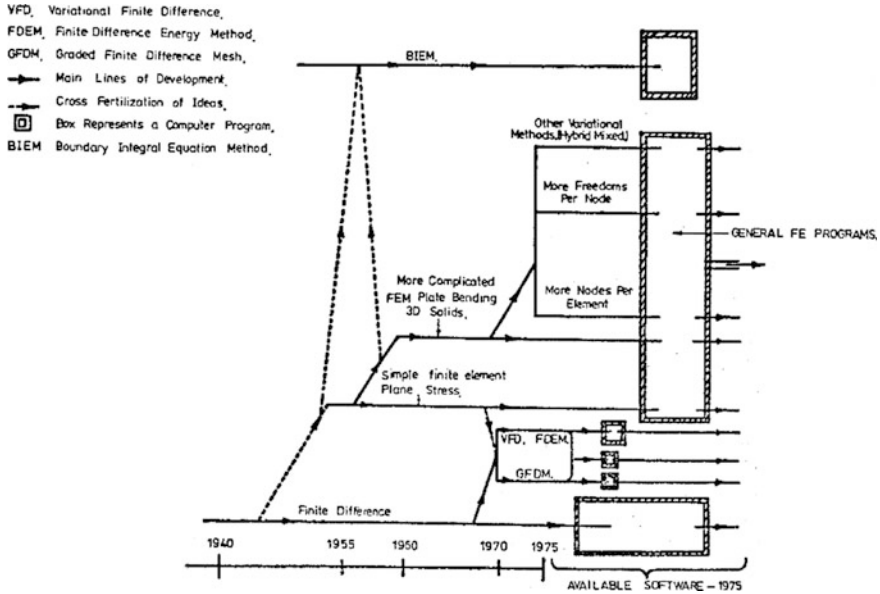
In particular, the figure shows the ratio between the maximum stresses in the presence of three grooves ( $\tau$ ) and of a single groove ( $\tau_0$ ) as a function of the ratio  $a/t$  (Fig. 5c) for the following geometric configuration:  $t = 0.1D$ ,  $r = 0.03D$ ,  $t_e/t = 0.08$ . Obviously, as the figure shows, the effect of shield decreases as the distance between grooves, i.e., as the ratio  $a/t$ , increases. Various geometries of multiple grooves are studied in the aforementioned paper by Manzella (1940a).

### 3 Numerical Methods for the Study of Torsion

*Computational Mechanics*, i.e., the use of numerical methods in stress analysis, saw rapid growth during the second half of the 20th century. Thus, a gradual transition occurred in the second half of the 20th century from *analog models* (electrical analogies for the study of torsion, in this case) to *structural physical models* (such as photoelasticity), and finally, to mathematical models, i.e., numerical methods. The development of these latter methods up to 1975 is shown in Fig. 8 (Henshell 1975). Historically, such methods are indicated as Finite Difference Methods (FDM), Finite Element Methods (FEM) and Boundary (Integral) Element Methods (BEM or BIEM).

With FDM and FEM, the domain is usually discretised into grids or elements, while BEM require the discretisation of the domain boundary, thus reducing the modelling and computational effort (Brebbia 1980). In general, BEM lead to more accurate results than those obtained by domain methods (Virzi Mariotti 1992). In fact, the Boundary Element Method provides a domain solution by numerically solving boundary integral equations containing unknowns of different types. In structural problems, these are, for instance, displacements and tractions, which are therefore calculated with the same degree of accuracy.

From a historical perspective, the first numerical works addressing the torsion problem have implemented the FDM, and were mainly released around the middle of the 20th century. Works employing FEM and BEM started to appear throughout



**Fig. 8** Historical development of numerical methods for analysing stresses (from Henshell 1975 Courtesy of the publishing house: Applied Science Publishers)

the second half of the 20th century. A progressive predominance of BEM and meshless methods has also been observed over time.

In the following subsections, some numerical results obtained with FEM and BEM are recalled, regarding the solution of the torsion problem of both constant cross section shafts and axisymmetric shafts. The selected results are only a minor part with respect to the cases treated in the literature. The criterion for their selection is, in particular, the possibility of proposing a direct comparison with results obtained through electrical analogies, outlined in the first part of the paper.

### 3.1 Shafts in Constant Cross Section

The formulation of the St. Venant torsion problem for beams with constant cross section by either a Poisson (Eq. 1) or a Laplace (Eq. 3) equation, has allowed for the implementation of a number of numerical techniques specifically developed for solving such types of differential equation. In fact, all three numerical approaches of FDM (e.g., Shumas 1949; Ely et al. 1960; Isakower et al. 1977) FEM (e.g., Zienkiewicz 1979) and BEM (e.g., Jawson et al. 1963; Chen 1993; Fuerst et al. 2000) have been successfully adapted.

The improved potentialities of numerical techniques have led researchers from the second half of the last century to focus more on complex torsion problems, such

as the presence of arbitrary cross-section shapes, more realistic boundary conditions, and multi-material composite bars (see, for instance, Darilmaz et al. 2007 for FEM and Barone et al. 2011 for BEM).

Only a few numerical works which reconsider the engineering cases earlier approached with analog and physical models are, indeed, traceable. This is apparent, for instance, by considering the most recent editions of reference textbooks for structural engineering design, such as Roark's (see, e.g., the edition of Young et al. 2002) or Peterson (1974), which still report many results and solutions from the earlier pioneering works performed with analog and physical models.

One example in particular is commented upon here, i.e., the circular full section shaft with a machined keyseat (Fig. 2a). For this case study of high engineering relevance, solutions are available from different approaches: Manzella's electrical analogy (Manzella 1940b), Leven and Freiser's photoelastic study (Leven 1949), also reported in Peterson (1974), Isakowes's FDM study (Isakower et al. 1977), also reported in Young et al. (2002), and the more recent works by Fuerst et al. (2000), based on BEM, and Pedersen (2010), based on FEM.

Comparison of results, in terms of stress concentration factor,  $K_t$ , from the previous works, is only possible for some selected geometric ratios,  $b/D$ ,  $t/D$ ,  $r/D$ , of the keyway shape.

Three comparisons in particular are proposed here:

#### First Comparison

Manzella (1940b) (Electrical Analogy) finds a  $K_t = 1.8$  for  $b/D = 0.25$ ,  $t/D = 0.076$ ,  $r/D = 0.0121$ , which underestimates the value of Pedersen (2010) (FEM) of a  $K_t = 2.24$  for  $b/D = 0.23$ ,  $t/D = 0.076$ ,  $r/D = 0.0121$ ;

#### Second Comparison

Leven (1949) (Photoelasticity) finds a  $K_t = 3$  for  $b/D = 0.25$ ,  $t/D = 0.125$ ,  $r/D = 0.0121$ , which is only 3 % higher than the value from Pedersen (2010) (FEM) of  $K_t = 2.91$  for the same geometric ratios;

#### Third Comparison

Fuerst et al. (2000) (BEM) finds a  $K_t = 3.36$  for  $b/D = 0.34$ ,  $t/D = 0.202$ ,  $r/D = 0.0118$ , which is almost identical to the value from Pedersen (2010) (FEM) of  $K_t = 3.38$  for the same geometric ratios.

### 3.2 *Axysymmetric Shafts*

Below, applications concerning axisymmetric shafts are considered. In particular, the analyses of the following cases are taken into account (Fig. 5a):

- collar shaft analysed through both BEM and FEM (Nigrelli 1994; Nigrelli and Virzi Mariotti 1995),

- shaft with variation of diameter—shouldered shaft ( $b/t \rightarrow \infty$ )—analysed through point-matching technique (Matthews and Hooke 1971),
- shaft with variation of diameter analysed through both BEM and FEM (Nigrelli and Virzi Mariotti 1995).

The values of stress concentration factor,  $K_{ts} = \tau_{max}/\tau_n$  (with  $\tau_{max}$  being the maximum shear stress and  $\tau_n$  the nominal stress in torsion calculated at minor diameter,  $d$ ) versus  $r/d$  are shown in Figs. 9 and 10.

Figure 9 shows  $K_{ts}$  values versus  $r/d$ , for the collar shafts case (assuming  $b/t = 1$ ) obtained through BEM and FEM (Nigrelli and Virzi Mariotti 1995) and through the Thum and Bautz electrical analogy (Giordano 1940b) for  $d/D = 0.8$  (Fig. 9a) and  $d/D = 0.9$  (Fig. 9b). The BEM and FEM  $K_{ts}$  values are, in general, smaller than those obtained by Giordano using Thum and Bautz’s electrical analogy (Giordano 1940b).

The BEM and FEM  $K_{ts}$  values for shafts with a variation of the diameter—shouldered shaft ( $b/t \rightarrow \infty$ )—(Nigrelli and Virzi Mariotti 1995) are shown in Fig. 10, together with the numerical values obtained through the point-matching technique (Matthews and Hooke 1971) quoted by Peterson (1974), and the experimental results obtained by:

- Giordano (1940c) through Thum and Bautz’s electrical analogy;
- Thum and Bautz (1934) through their electrical analogy;
- Jacobsen’s electrical analogy (Jacobsen 1925) quoted by Peterson (1953).

The BEM, FEM and point-matching method’s numerical values are all very close to each other.

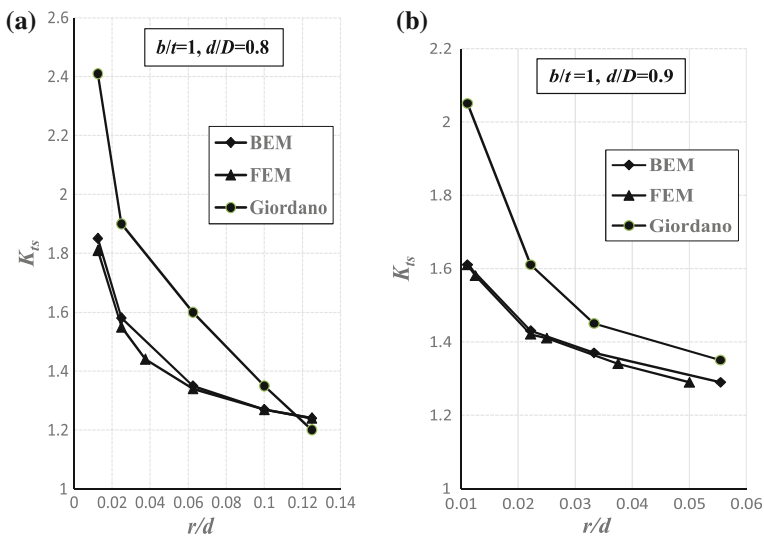
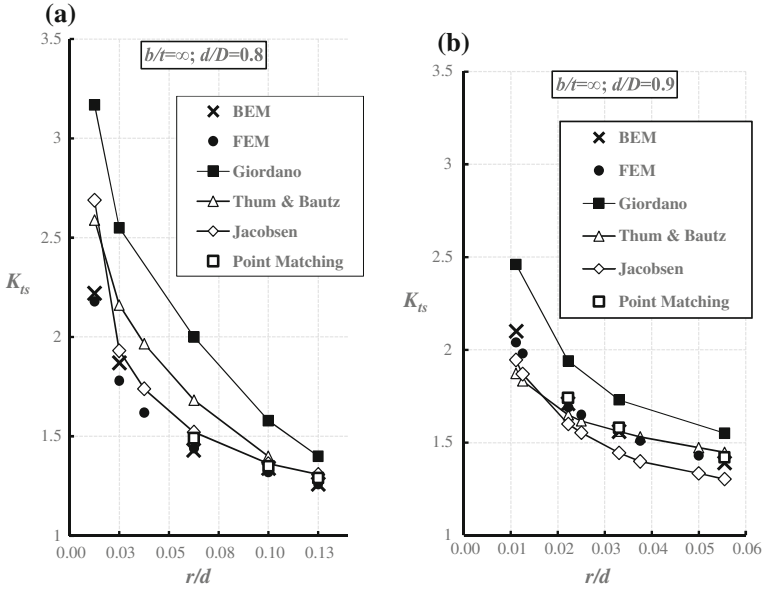


Fig. 9  $K_{ts}$  values for collar shafts ( $b/t = 1$ ); a  $d/D = 0.8$ , b  $d/D = 0.9$



**Fig. 10**  $K_{ts}$  values for shaft with variation of diameter—shouldered shaft ( $b/t \rightarrow \infty$ ); **a**  $d/D = 0.8$ , **b**  $d/D = 0.9$

Regarding the  $K_{ts}$  values obtained through the electrical analogies, instead:

- the results obtained by Giordano are greater than all others;
- the results obtained by Thum and Bautz are smaller than the results obtained by Giordano and greater than the numerical results for  $d/D = 0.8$ ; instead, for  $d/D = 0.9$ , they are in agreement with (for  $r/d > 0.033$ ) or lesser than (for  $r/d < 0.033$ ) the numerical results;
- the results obtained by Jacobsen are usually close to the numerical values, for  $d/D = 0.8$  (except for  $r/d = 0.0125$ ), otherwise, they are generally lower than numerical values for  $d/D = 0.9$ .

## 4 Considerations and Conclusions

This paper concerns the methods used in the analysis of shear stresses in shafts. In particular, the paper describes the transition from methods based on electrical analogies to numerical methods. Numerical methods are largely used in the literature for the study of torsion stresses in shafts both of constant cross section and axisymmetric. All three numerical methods, i.e., FDM, FEM, BEM, have been employed to analyze stresses in shafts of engineering interest; for example,

Pedersen (2010) employs a FEM technique in the case of a circular shaft with a parallel keyway.

In this work, a comparison of Pedersen's data with others in the literature, obtained through different techniques, is presented in Sect. 3.1. In general, the estimates by Pedersen are very close to the results obtained through both BEM and experimental photoelastic analysis, while a difference of about 20 % in the stress concentration coefficient is determined in the comparison with data obtained by Manzella through the method of electrical analogy. The few data available do not allow for a more in-depth comparison between results from numerical analyses and specific results based on electrical analogies.

For axisymmetric shafts, BEM and FEM  $K_{ts}$  values are very close to each other, as a reciprocal validation of the methods. The same was obtained for shafts in traction or in bending (Nigrelli and Virzi Mariotti 1996, 1997). The  $K_{ts}$  values obtained through BEM and FEM are also very close to values determined through the numerical technique of point-matching, quoted in (Peterson 1974). Moreover, the values obtained through the photoelastic technique (Fessler et al. 1969) and the numerical results are in good agreement for small values of  $r/d$ .

Results of the electrical analogies depend on the analogy used (Jacobsen or Thum and Bautz), and, for Thum and Bautz's analogy, on the specific experimental set-up. Summarizing:

- results obtained by Giordano (based on Thum and Bautz's analogy) always overestimate  $K_{ts}$  values both for collar shafts and for shafts with variation of diameter;
- for shafts with variations of diameters, the results by Thum and Bautz (through Thum and Bautz's analogy) and Jacobsen are smaller than the results obtained by Giordano; furthermore, the results are in agreement, overestimate or underestimate the numerical values of  $K_{ts}$ , depending on the parameters  $d/D$  and  $r/d$ .

Although the results obtained through the electrical analogies present a certain degree of variability, it is clear that experimental mechanics made it possible to determine the shear stress concentration factors in shafts when computational mechanics was not yet sufficiently developed.

## References

- Ajovalasit A, Nigrelli V, Pitarresi G, Virzi Mariotti G (2013) Torsional stress concentrations in shafts: from electrical analogies to numerical methods. IFToMM workshop on history of mechanism and machine science, University of Palermo, 21st–22nd Nov 2013. Proceedings published by Edizioni Scientifiche e Artistiche, Naples 01/31/2014. ISBN: 9788895430843
- Ajovalasit A, Nigrelli V, Pitarresi G, Virzi Mariotti G (2014) On the history of torsional stress concentrations in shafts: from electrical analogies to numerical methods. *J Strain Anal Eng Des* 49:452–466
- Barone G, Pirrotta A, Santoro R (2011) Comparison among three boundary element methods for torsion problems: CPM, CVBEM, LEM. *Eng Anal Boundary Elem* 35(7):895–907



- Beadle CW, Conway HD (1963) Conducting-sheet analogy for stress concentrations in twisted structural sections. *Exp Mech* 3(8):198–200
- Biezeno CB, Koch JJ (1933) Über einige Beispiele zur elektrischen Spannungsbestimmung. *Ingenieur—Archiv* 4:384–393
- Brebbia CA (1980) *The boundary element method for engineers*. Pentech Press, London
- Chen F, (1993) Solution of torsional problems by BEM. *Transactions on modelling and simulation*, vol. 1, WIT Press
- Cranz H (1933) Experimentelle Lösung von Torsions Aufgaben. *Ingenieur—Archiv* 4:506–509
- Darılmaz K, Orakdogan E, Girgin K (2007) Torsional rigidity of arbitrarily shaped composite sections by hybrid finite element approach. *Steel Compos Struct* 7:241–251
- Den Hartog JP, McGivern JG (1935) On the hydrodynamic analogy of torsion *J Appl Mech* 2(2): A46–A48
- Ely JF, Zienkiewicz OC (1960) Torsion of compound bars—a relaxation solution. *Int J Mech Sci* 1 (4):356–365
- Fessler H, Rogers C, Stanley P (1969) Shouldered plates and shafts in tension and torsion. *J Strain Anal* 4(3):169
- Fuerst A, Sprysl H (2000) Determination of polar moment of inertia and stress concentration of shafts under torsion load with arbitrary cross section. *Int Ser Adv Boundary Elem* 8:109–116
- Giordano G (1940a) Ricerca delle tensioni in alberi soggetti a torsione. apparecchiature per la determinazione sperimentale di esse negli alberi di rivoluzione. *Tecnica Italiana*, febbraio 1940
- Giordano G (1940b) Coefficiente di forma per alberi con un risalto soggetti a torsione. *Tecnica Italiana*, aprile 1940
- Giordano G (1940c) Fattori di forma per alberi con variazione di diametro soggetti a torsione. *Tecnica Italiana*, maggio 1940
- Griffith AA, Taylor GI (1917) The use of soap films in solving torsion problems. *Proc Inst Mech Eng* 1917:755–809
- Griffith AA, Taylor GI (1918) The application of soap films to the determination of the torsion and flexure of hollow shafts. Technical report of the advisory committee for aeronautics 1917; vol. 392
- Henshell RD (1975) A survey of the use of the finite element method in stress analysis. In: Stanley P (ed) *Computing development in experimental and numerical stress analysis*, Applied Science Publishers, London, pp 1–19
- Hetényi M (ed) (1950) *Handbook of experimental stress analysis*. John Wiley, New York
- Higgins TJ (1945a) Analogic experimental methods in stress analysis as exemplified by Saint-Venant torsion problem. *Proc SESA II*(2):17–27
- Higgins TJ (1945b) Stress analysis of shafting as exemplified by Saint-Venant torsion problem. *Proc SESA III*(1):94–101
- Huth JH (1950) Torsional stress concentrations in angle and square tube fillets. *J Appl Mech* 17 (December):388–390
- Isakower RI, Barnas RE (1977) Torsional stresses in slotted shafts. *Mach Des* 49(21):100–103
- Jacobsen LS (1925) Torsional stress concentrations in shafts of circular cross section and variable diameter. *Trans ASME* 47:619–641
- Jawson MA, Ponter RA, (1963) An integral equation solution of the torsion problem. *Proc R Soc London* 275(A):237–46
- Kobayashi AS (ed) (1987) *Handbook on experimental mechanics*. Prentice Hall, Englewood Cliffs
- Leven MM (1949) Stresses in key ways by photoelastic methods and comparison with numerical solution. *Proc Soc Exp Stress Anal* 7(2):141
- Manzella G (1939) Determinazione sperimentale delle tensioni torsionali in aste prismatiche. *Tecnica Italiana*, marzo 1939
- Manzella G. (1940a) Sullo scarico delle tensioni torsionali prodotte da incassi circolari negli alberi. *Tecnica Italiana*, marzo 1940
- Manzella G (1940b) Influenza del grado di cavità sul coefficiente di forma di alberi con tagli di chiave. *Tecnica Italiana*, aprile 1940

- Matthews GJ, Hooke CJ (1971) Solution of axisymmetric torsion problems by point matching. *J Strain Anal* 6(2):124–133
- Nigrelli V (1994) Alberi con colletto soggetti a torsione: determinazione dei fattori di forma con il metodo degli elementi di contorno—XXIII Convegno Naz. AIAS, Cosenza, 1994
- Nigrelli V, Virzi Mariotti G (1995) Stress concentration factor in collar and shouldered shafts in torsion. *Eng Anal Boundary Elem* 16:71–77
- Nigrelli V, Virzi Mariotti G, (1996) Fattori di concentrazione delle tensioni in alberi con colletto soggetti a trazione o a flessione—Organi di Trasmissione, Maggio 1996, pp 160–165
- Nigrelli V, Virzi Mariotti G (1997) Stress concentration factor in collar and shouldered shafts in traction or in bending. *Eng Anal Boundary Elem* 20:245–252
- Pedersen NL (2010) Stress concentrations in keyways and optimization of keyway design. *J Strain Anal Eng Des* 45(8):593–604
- Peterson RE (1953) Stress concentration design factors. John Wiley & Sons, New York
- Peterson RE (1974) Stress concentration factors. John Wiley & Sons, New York
- Prandtl L (1903) Zur Torsion von prismatischen Staben. *Physikalische Zeitschrift* 4:758–759
- Sharpe WN (ed) (2008) Handbook of experimental solid mechanics. Springer, New York
- Shumas FJ, (1949) The effect of a slot on the stresses and rigidity of a shaft subject to pure torque. Thesis dissertation, University of British Columbia (<http://hdl.handle.net/2429/41237>)
- Thum A, Bautz W (1934) Die Ermittlung von Spannungsspitzen in Verdrehbeanspruchten Wellen durch ein elektrisches Modell. *Verein Deutscher Ingenieure (VDI)* 78:17
- Timoshenko S, Goodier JN (1951) Theory of elasticity, 2nd edn, McGraw-Hill, New York
- Virzi Mariotti G (1992) BEM applications on an external problem, comparison with both theoretical and finite element results and observations on divergence strip. *Eng Anal Boundary Elem* 10(3):267–271
- Waner NS, Sokora WW (1953) Stress concentrations for structural angles in torsion by the conducting sheet analogy. *Proc SESA XI*(1):19–34
- Young WC, Budynas RG (2002) Roark's formulas for stress and strain, 7th edn. McGraw Hill, New York (Chapter 10)
- Zienkiewicz OC (1979) Numerical methods in stress analysis—the basis and some recent paths of development. In: Holister GS (ed) Developments in stress analysis, vol. 1, Applied Science Publishers, London (Chapter 1)

**Part V**  
**Robots and Human-Driven**  
**Automata**

# The Automaton Nysa: Mechanism Design in Alexandria in the 3rd Century BC

Teun Koetsier and Hanfried Kerle

**Abstract** The paper is about the automaton Nysa, which operated in the Grand Procession of Ptolemy Philadelphus in the first half of the 3rd century BC. What was its design? We discuss several possible answers to this question. We give special attention to the mechanism that made Nysa stand up and sit down again. We argue that a cam was used and that the motion was slowed down either by means of a sprocket chain or—as Lewis suggested in 1997—by means of two gear wheels. We feel that the problem dealt with in this paper could fruitfully be used in engineering education.

## 1 The Statue of Nysa

We have a description by Kallixeinos of Rhodes of a Grand Procession that took place in Alexandria in the early third century BC. In Kallixeinos' description, excerpted by Athenaeus of Naucratis and written down in the 5th book of his *Deipnosophistai*, we read:

[...] a four-wheeled cart was led along by sixty men [...] twelve feet wide, on which there was a seated statue of Nysa twelve feet tall, wearing a yellow chiton woven with gold thread, and wrapped in a Laconian himation. This statue stood up mechanically without anyone laying hand on it, and it sat back down again after pouring a libation of milk from a golden phiale. (Rice 1983, pp. 10–13)

---

T. Koetsier (✉)

Department of Mathematics Faculty of Science, Vrije Universiteit,  
De Boelelaan 1081, 1081 HV Amsterdam, The Netherlands  
e-mail: t.koetsier@vu.nl

H. Kerle

Institut für Werkzeugmaschinen und Fertigungstechnik, TU Braunschweig,  
Langer Kamp 19b, D-38106 Brunswick, Germany  
e-mail: h.kerle@t-online.de

It is possible that Nysa was a personification of the city where Dionysus was reared. The statue “stood up mechanically without anyone laying hand on it” and poured a libation from a phiale. A libation is a ritual offering and a phiale is a wide shallow bowl. It has been suggested that Nysa was the work of the famous inventor Ktesibius. It is exactly the kind of toy for which Vitruvius says that Ktesibius was famous. Ktesibius lived about 270 BC. (Drachmann 1963, p. 10). It is not clear when exactly this Grand Procession took place, but it is quite possible that it was between 274 and 270 BC. (Rice 1963, p. 14).

There are two questions about this that are interesting for a mechanical engineer. The first one is: What kind of mechanism was used to make Nysa automatically stand up and sit down again? The second one is: What kind of mechanism brought about the pouring of the libation of milk? In this paper, we will primarily deal with the first question. First, however, we must describe the Grand Procession.

## 2 The Grand Procession

At the end of the years of Athenian glory in the 5th and 4th centuries BC, dramatic events radically changed the world. Macedonia rose, King Philip of Macedonia prepared the ground, and his son Alexander (356–323) took the dynamic of the Macedonian conquest to unprecedented lengths. Alexander conquered the Persians and pressed on into India. His men were the first westerners to hear about the Abominable Snowman. It was the beginning of the *Alexandrian or Hellenistic Period* in Greek history.

Athens was no longer the centre of the world. The successors of Alexander in Egypt, the Ptolemies, turned Alexandria, the city founded by Alexander, into the greatest city of the age. They founded the famous Museum with its library in which they collected scholars and books. Under the Ptolemies, Alexandria became the power house of Greek culture (Fraser 1972). Men with very different backgrounds and abilities were thrown together and inevitably influenced each other. Alexandria became a major centre of scientific investigation and many feel that the theory of machines and mechanism was born in Alexandria (Fig. 1).

The Grand Procession shows that Alexandria must have been an unbelievable place. It consisted of a long sequence of sectional processions. First, the procession of the Morning Star marched, because the Grand Procession “began at the time when that aforementioned star appeared in the sky” (Rice 1963, pp. 8–9). Then came a procession named after the parents of the kings. Then followed processions devoted to all the Gods, and finally came a procession devoted to the Evening Star. This procession of the Evening Star came last of all, “since the season brought the time of day to the point when that star appeared”.

The planet Venus is close to the Sun. Sometimes, she is visible as the Morning Star. Then comes a period in which she is not visible for eight days, because she is too close to the Sun, and then she appears again as the Evening Star. Maybe the beginning and the end of the procession merely corresponded to the beginning of

**Fig. 1** The woman on the left wears a chiton and the two others a chiton and a himation (Source <http://en.wikipedia.org/wiki/File:ChitonAndHimation.gif>)



the day (Morning Star) and the end of the day (Evening Star). This would suggest that the procession did not last any longer than one day. Yet, at the end of the procession, the infantry and cavalry forces would march past, which in itself, according to some calculations, could have taken up to ten hours. This implies the probability that the procession was spread over several days.

One of the sectional processions was devoted to Dionysus, the god of wine. Large carts carrying statues and tableaux relating to the mythology of Dionysus made up the bulk of this procession, accompanied by hundreds of followers of Dionysus, priests and other officials. The first cart held a huge statue of Dionysus. We are, however, interested in one of the carts that followed it in this procession: the one with Nysa on it. The Ptolemies, undoubtedly, would have loved it. The big moving statue only added to the general idea that their kings could realize the impossible.

The procession must have had an enormous impact on its beholders. We will quote Kallixeinos once more. After Nysa,

[...] another four-wheeled cart, 30 feet long by 24 feet wide, was pulled by 300 men, on which there was set up a wine-press 36 feet long by 22½ feet wide, full of ripe grapes. Sixty Satyrs trampled them as they sang a vintage song to the flute, and a Silenos superintended them. The grape juice flowed through the whole street. Next there came a four-wheeled cart, 37½ feet long by 21 feet wide, which was pulled by 600 men. On it was an askos made of Leopard skins which held 3.000 measures. As the wine was released little by little, it also flowed over the whole street.

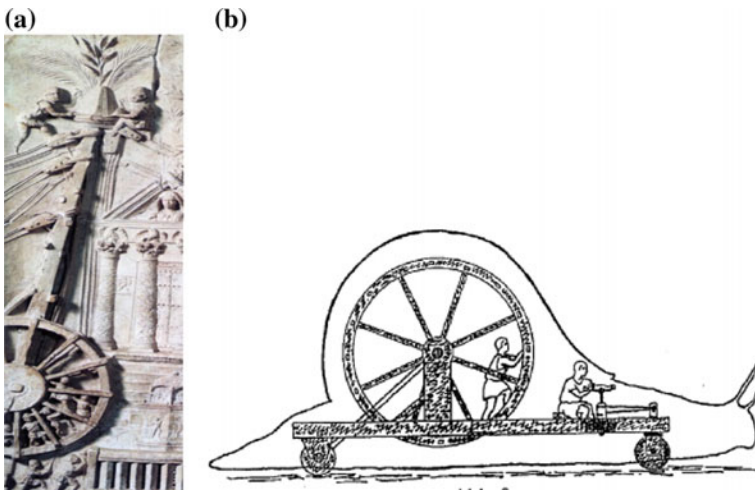
The account seems incredible. Yet nothing in the description can be disproven. On the contrary, many details can be corroborated by other sources.

### 3 Some Preliminary Remarks

**Originality:** The Nysa was not the first automaton in a Dionysiac procession. In 308 BC, in Athens, Demetrius of Phalerum had an enormous snail move in front of such a procession spitting out slime (Coleman 1996, p. 56). For a hypothetical reconstruction, see Rehm (1937). Rehm assumed that a man inside the snail was walking on a treadmill, which made the snail move (see Fig. 2a). The treadmill existed in classical antiquity. Rehm refers to the reconstruction by Erwin Schramm of the helepolis (the “city taker”) built by Posidonius, a huge mobile siege machine briefly described by Philon. Schramm assumed that it was moved by means of a treadmill (Schramm 1918). It was built for Alexander the Great for the siege of Tyre.

**Size:** What was the size of the statue? The statue of Nysa was 12 ft. tall, according to Kallixeinos’ report. Because, according to the description of the procession, the cart that carried the statue of Nysa was preceded by another cart with a statue of Dionysus on it, 15 ft. tall, it is not unreasonable to assume that the sitting statue was 12 ft. tall. Another question concerns the weight of the statue. If it was a heavy statue, we may have to consider toggle linkages. Marble would have been too heavy, so very probably, the statues were made of terracotta or (hollowed) wood, plaster and wax, painted realistically. We should also consider the possibility that a reservoir with milk for the libation was inside the statue and had to be lifted as well.

**Robustness:** The Nysa was big, two and a half times the size of a human being. Coleman, who studied the theatrical aspects of the procession, emphasized that such a huge automaton was meant to impress the world (Coleman 1996, p. 57). This implies that the design must have been robust, because the king would not have



**Fig. 2** a. Detail from the Haterii tombstone (1st century AD). b Rehm’s reconstruction of the automatic snail (Rehm 1937)

appreciated it if this expression of Alexandria's technological superiority had failed. Robustness was also required because the procession covered a considerable distance. It started in the stadium of Alexandria, which was an ideal place for official guests to see the spectacle, but it would have progressed onto some of the main streets of Alexandria in order to make the spectacle visible to as many people as possible. The boulevard used may very well have been what the Romans later called the *Via Canopica*, the city's principal artery, easily comparable to Rome's *Via Sacra* (Goehring 1997, p. 30). It took a later pilgrim nine hours to traverse the boulevard from one end to the other. The boulevard would have been shorter in the first half of the 3rd century BC, or at least the route of the procession would have been, but nevertheless, the Nysa had to function faultlessly for at least a whole day.

**Our approach:** Was it really an automaton that worked automatically or did the mechanism receive some help from one or more operators inside the cart? We will assume that the mechanism that made the Nysa get up and sit down again was a real automaton.

Moreover, we will distinguish between two different questions. (1) How was the up and down movement brought about? (2) Did the Nysa get up once during one rotation of the wheels or less often, in other words, was the motion slowed down, and if so, how?

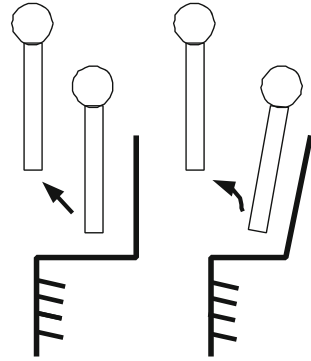
We will try to answer the two questions in the following way. On the one hand, our problem is a problem of design belonging to the area of mechanical engineering. On the other hand, our answer will also depend on the level of technological knowledge in classical antiquity. We will start from the point of view of a modern mechanical engineer, and, while we generate possible solutions, gradually introduce our knowledge of technology in antiquity.

## 4 How Was the up and Down Movement Generated? by Means of a Linkage?

How was the up and down movement generated? Since all information that we possess on the Nysa is in the description of the procession by Kallixeinos, we can only guess. She wore a chiton and a himation (see Fig. 1), which makes it highly probable that her legs were not visible. Let us assume that the chair was a closed throne that could hide the mechanism, and that when she was sitting, the chiton and the himation completely hid the lower limbs. There will have been some construction underneath the robe to bring about the right relief in the clothing. This means that we can concentrate on the motion of the trunk. We will assume that back, neck and head were one rigid construction. The question then is: How did it move from a sitting to a standing position and vice versa? We will only consider two possibilities in this paper (see Fig. 3). The first possibility is that the upper part of the body remained in a vertical position and was translated to and fro.



**Fig. 3** The two possible movements of the upper part of the body: translation and rotation

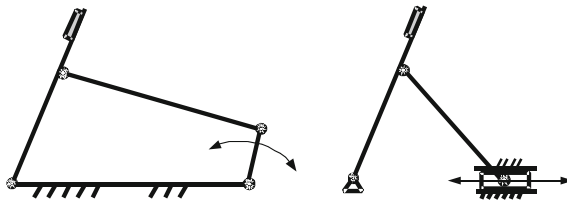


The second possibility is that the upper part of the body leaned backwards against the back of the chair in a sitting position and was (translated and) rotated towards its vertical position in order to have a standing statue.

It is interesting that modern engineers asked to come up with an answer to our question are inclined to consider solutions by means of a linkage. They might suggest solutions based on the mechanisms of Fig. 4. The Nysa is rotated and the rotation is brought about by an operator inside who handles the input of the mechanisms. Obviously, the dimensions and the positions of the pivots must be chosen in such a way that the upper part of the body of the Nysa is lifted over a distance of circa 3 ft., assuming the Nysa was 15 ft. tall in the standing position.

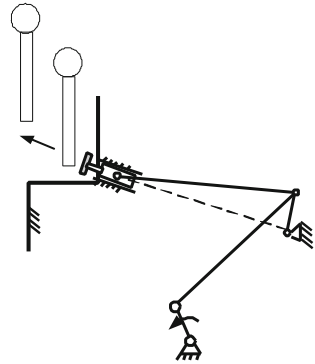
However, we rejected the possibility that it was not a real automaton. If we stick to linkages, a modern engineer could now suggest the solution shown in Fig. 5 in order to get a real automaton.

In modern terminology, this is based on a version of Watt's six-bar chain. It can be designed in such a way that the standing figure corresponds to a position in which we have a toggle effect. Moreover, the input could be a continuous rotation taken from the wheels. In principle, the upper part of the body of the Nysa could be moved by means of such a mechanism. Let us assume that a mechanism like the ones in Fig. 5 was used and that the input rotation was directly taken from the rotating wheels. Figure 6 shows how the wheels could have driven the motion of the Nysa in combination with the mechanisms of Fig. 5.

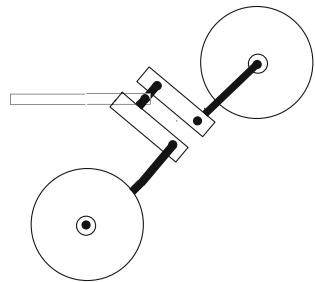


**Fig. 4** Four-bar linkages with two different input links, crank (left) and slider (right)

**Fig. 5** Six-bar linkage with one double rotary joint, crank input link and slider output link



**Fig. 6** Crank input link driven by means of an axle with two wheels

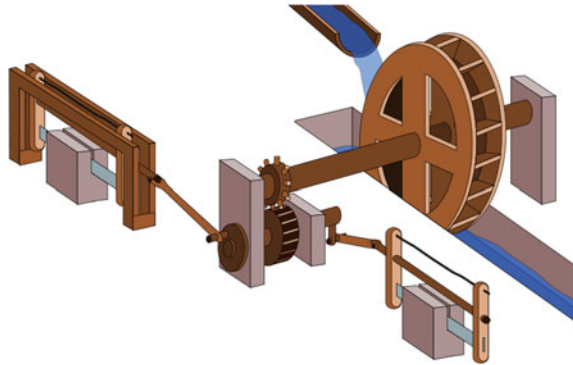


The solutions sketched above could have been realized in some form by the Alexandrian engineers. Yet, on the basis of what we know about technology in classical antiquity, this must be considered to be improbable. With the exception of Fig. 4 (right), they are based on the use of a crank. The history of the crank is shrouded in mist, but it certainly shows up late. Half a century ago, Lynn White Jr. argued that there was no evidence whatsoever to show that the peoples of the classical Mediterranean knew of the crank: an arm rotating about an axle with a connecting rod attached to the arm (White 1964, pp. 103–107). After having emphasized its importance by saying,

Next to the wheel, the crank is the most important mechanical device, since it is the chief means of transforming continuous rotary into reciprocating motion, and the reverse, (White 1964, pp. 103–104),

White expressed his amazement that it was invented so late and accepted so slowly. Although we find it very natural nowadays to apply a crank in many situations, this was, indeed, not the case in classical antiquity. But White’s thesis cannot be maintained. In one of the Roman barges found in Lake Nemi (ca. A. D. 40), a slotted disk was discovered that strongly suggests that it was driven by means of a crank handle. There are also other references to even earlier crank handles in the Roman Empire (Ritti et al. 2007, pp. 138–163). And there is more. In the crank handle, the human arm is the connecting rod. The earliest known machine in which

**Fig. 7** Reconstruction of a Roman sawing machine from the 3rd century AD (Ritti et al., 2007 p. 148)



there very probably was a crank and a connecting rod was a Roman sawing machine from the 3rd century AD (see Fig. 7). The crank also appeared in China, and later in the near East in the Middle Ages. For example, in 1206, Al Jazari, in his fourth machine, has a crank with a pin that slides in a slot of a rotating rod (see Al Jazari 1979).

Although White's thesis has been refuted, the fact that cranks show up so late in antiquity implies that use of a crank and connecting rod in the Nysa cannot be supported by what we know about mechanical knowledge in classical antiquity.

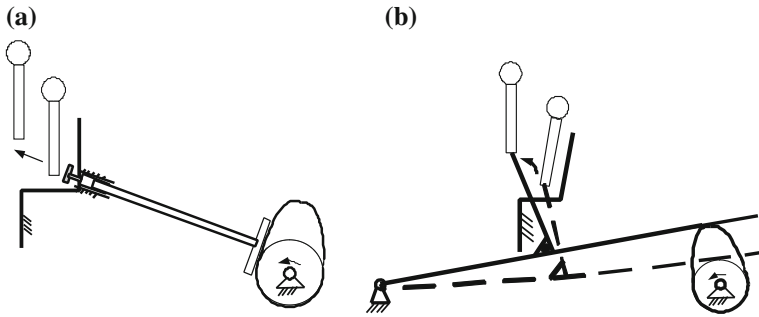
## 5 The up and Down Movement Generated by Means of a Cam!

Let us now consider the possibility that a cam was used. Figure 8a gives a possible solution. A cam brings about the translation of the Nysa from a seated to a standing position. In Fig. 8b, we present another possible solution. The cam does not immediately push the Nysa upwards, but pushes a lever upward, which is connected rigidly to the Nysa. In this solution, we realize a rotation of the Nysa. We prefer this last solution. Actually, such a solution has been suggested by Rice (1983, p. 64). Yet, Rice, who did not present a drawing of her idea, seems to mix the solutions of Fig. 8a, b. She talks about a camshaft and a lever, while the Nysa described in her description moves in an up and down *linear* movement. Maybe she had the solution of Fig. 9 in mind.

How anachronistic are these solutions? Unlike the linkages discussed above, cams show up quite early in Greek mechanics. Wilson wrote:

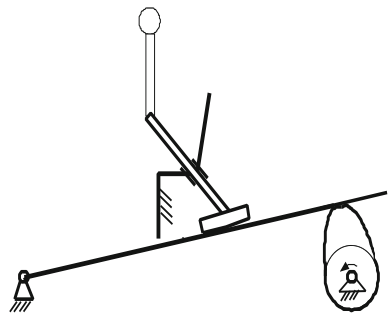
The cam itself is attested in water-driven automata from the third century BC., so there is no inherent problem with the concept that the transference of rotary to reciprocating linear motion was applied in antiquity. (Wilson 2002)

Wilson refers, at this point, to Lewis, who has argued that water-powered grain pounders using trip hammers driven by cams were already in use in antiquity before



**Fig. 8** Two solutions based on cam mechanism for linear (a) and rotary (b) movement of the statue

**Fig. 9** Mixed solution combining elements of Fig. 7a, b

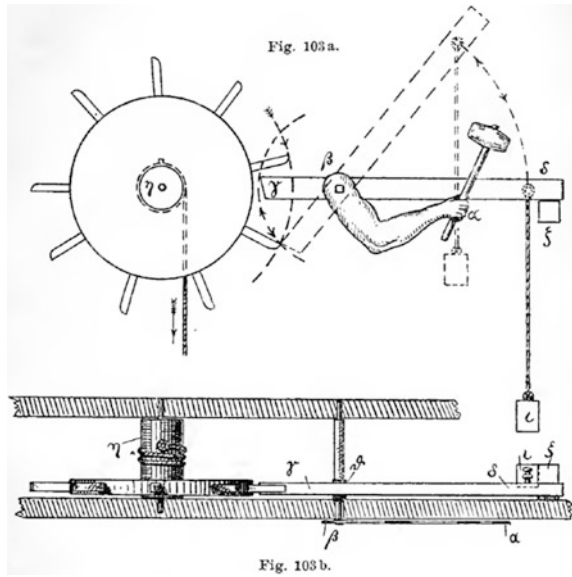


the 1st century AD., earlier than was previously thought (Lewis 1997). In this context, Lewis also refers to Philo’s design of a puppet carpenter from Philo’s *Automatopoeica*, a book on toys and automata, of which fragments are extant (see Fig. 10). Philo lived from ca. 289 until ca 220 in Alexandria. An arm with a hammer is made to rock up and down by means of a hidden mechanism consisting of a weighted lever lifted by the teeth of a wheel. The wheel is turned by a weighted string. Another nice example of a small scale cam given by Lewis is Apollonius’ flute player (see Fig. 11). This flute player was described by the brothers Musa, the Banu Musa, in the 9th century (Farmer 1931). It is an easy example of a programmable machine (Koetsier 2001).

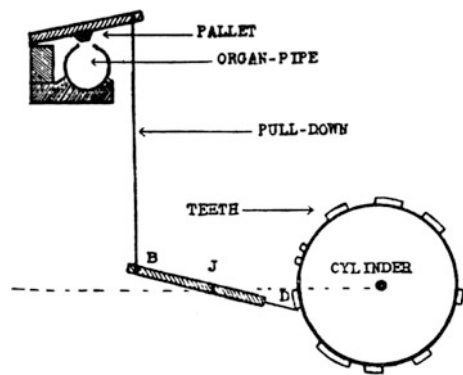
The Banu Musa must have been familiar with a text from circa 240 BC by Apollonius, the geometer and carpenter, on a similar automatic flute player. For an argument that this Apollonius must be Apollonius of Perga, noted for his work on conic sections, see (Lewis 1997, pp. 49–50).

In summary, it indeed looks extremely probable that the cam was used in Alexandria in the 3rd century BC, and that it was discovered at the end of the 4th or at the beginning of the 3rd century BC. By the way, we have not seen Bertrand Gille’s paper (1954) on the history of the cam.

**Fig. 10** Philo’s puppet arm. Reconstruction by Schmidt (1899)



**Fig. 11** Reconstruction of part of Apollonius’ automatic flute player. Source (Farmer 1931), p. 101



## 6 Was the Movement Slowed Down?

Let us assume that the cart had wheels with a diameter of 2 m. Without a mechanism that would slow down the motion, taking the input from the wheels in the way sketched in Figs. 8 and 9 would lead to a situation in which the Nysa would get up and sit down once every six meters. Processions move slowly. Three kilometres per hour is a normal speed. This means that one rotation of the wheel takes about 7 s. With the mechanisms in Figs. 8 and 9, the statue would get up and sit down again over a period of 3.5 s. During the other 3.5 s, the statue would sit on its chair. It is quite possible that this is what happened. If the chariot stopped often, which all too easily happens in a procession, frenetically undignified movements would be avoided.

It is interesting in this context to consider the Hindu temple chariots. They carry representations of Hindu gods and are used on festival days when many people pull the chariot. The chariots move slowly. Wheels with a diameter of two meters occur (see Fig. 12). Some chariots even have wheels with a diameter of three meters. With wheels with a 3-meter diameter, the moving Nysa would have a period of 11 s in which to give its performance.

Yet, we cannot exclude the possibility that the designer of the Nysa used a mechanism to slow down the motion. Slowing down a rotation can be done in different ways, for example, by means of a belt. A small wheel on the axle of the front wheels could be connected to a big wheel on the camshaft. However, the earliest known successful example of the transmission of power by means of a belt was the spinning wheel. It appeared in the 13th century and very probably came from the East (see Fig. 13). Usually, India is mentioned as its source. Needham writes that driving belts were used in the early middle ages in the silk industry in China (Needham 1965, p. 107). Apparently, we don't have examples of driving belts from before Christ, which makes it highly improbable that they were used in the Nysa.

How about sprocket wheels and gearwheels? They could also have been used to slow down the frequency of the statue standing up. The Greeks invented the crane ca 500 BC. Soon, ratchet wheels for holding a windlass against a load were designed. Then, sprocket wheels used to drive chains were invented. Two of such machines are described by Philo. One concerns a chain of buckets and the other one

**Fig. 12** Temple car in Chennai, India. Photo: Bernard Gagnon. *Source* [http://www.wikiwand.com/en/Temple\\_car](http://www.wikiwand.com/en/Temple_car)



**Fig. 13** Picture of a spinning wheel. France last quarter of the 13th century or first quarter of the 14th century from the Smithfield Decretals (British Library)



is a chain for a repeated catapult built on Rhodes by a Dionysius of Alexandria, whose work possibly dates to before 282 BC.

Conceptually close to the sprocket wheel driving a chain is the rack and cog-wheel arrangement. Vitruvius (1st century BC) describes a water clock invented by Ktesibios in which a container is filled with water at a constant speed. On top of the water is a float on which a vertical rod is placed in conjunction with a rotating wheel. Vitruvius writes (quoted and translated by Drachmann):

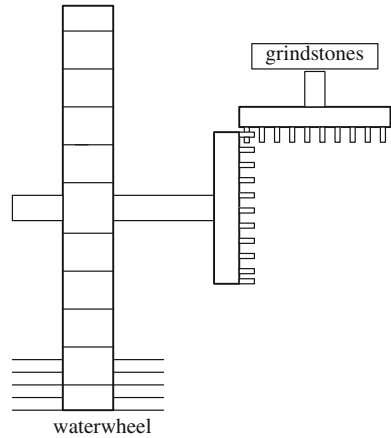
They [the rod and the wheel] are provided with equally spaced teeth, which, impinging on each other, cause proper turnings and movements. Also, other rods and other wheels, with teeth after the same fashion, driven by this single movement by their turning cause effects and varieties of movements, by which puppets are moved, cones are turned, pebbles and eggs are dropped, horns are sounded and other by-plays. (Drachmann 1963, p. 192)

Vitruvius had access to Ktesibios' work. Looking at such a quotation, it seems almost certain that someone like Ktesibios must have realized that one cogwheel could drive another one. The earliest cogwheels very probably had parallel axes. Soon, other types appeared. See Fig. 14 for the structure of the watermill described by Vitruvius.

In the text *Mechanical Problems*, probably written at the beginning of the 3rd century BC by a pupil of Aristotle, wheels driving each other are discussed, although no teeth are mentioned. Yet, this source supports the supposition that gear wheels were known at the time the Nysa was built.

In this respect, another important point is brought up. It is easy to underestimate the sophistication of the ancients. The discovery of the Antikythera mechanism from between 150 and 100 BC, and in particular, recent research concerning the mechanism, has made this very clear. The story of the Antikythera mechanism is fascinating. Freeth et al. (2006) published their solution to the major riddles that the remains of the mechanism presented. See (Koetsier 2009) for a brief survey of the way in which our understanding of its design developed. Of course, there is an important distinction between precision mechanical mechanisms for which the forces are small and applications with heavy loads. And yet, the mechanical sophistication of Greek and Roman engineers can only have been greater than what research has so far unearthed. The case of the Antikythera mechanism proves that it

**Fig. 14** Gears in a mill driven by an undershot vertical water wheel (1st century BC)

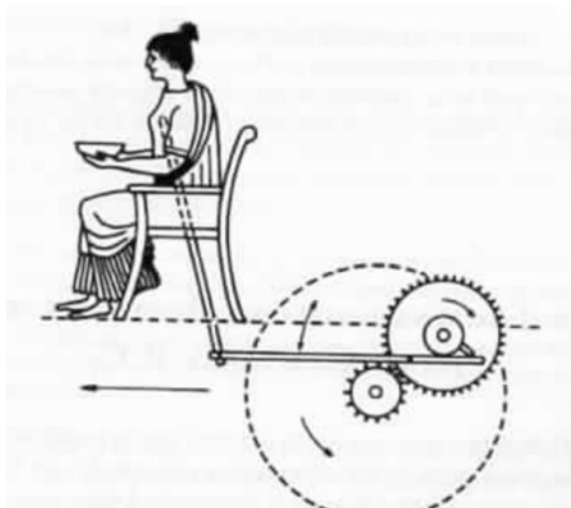


is very easy to be wrong in one's assumptions on the technological knowledge of antiquity.

In 1997, Lewis suggested that a pair of gear wheels was used to slow the movement of the Nysa, as shown in Fig. 15. The wheels' ability to retard the up and down movement, meant that, even when the sixty men pulling the cart would accelerate a bit, the Nysa would still not behave in too undignified a manner.

Of course, it is also possible that sprocket wheels and a sprocket chain were used. Above, we mentioned Dionysius' repeating catapult. Soedel and Foley have presented a reconstruction based on two pentagonal gears and a chain connecting them (Soedel and Foley 1979). The Saalburg Museum in Hessen, Germany has a copy of such a catapult built by the German officer and engineer Erwin Schramm

**Fig. 15** The Nysa according to Lewis (1997, p. 85).  
*Courtesy of Dr. Michael J.T. Lewis*





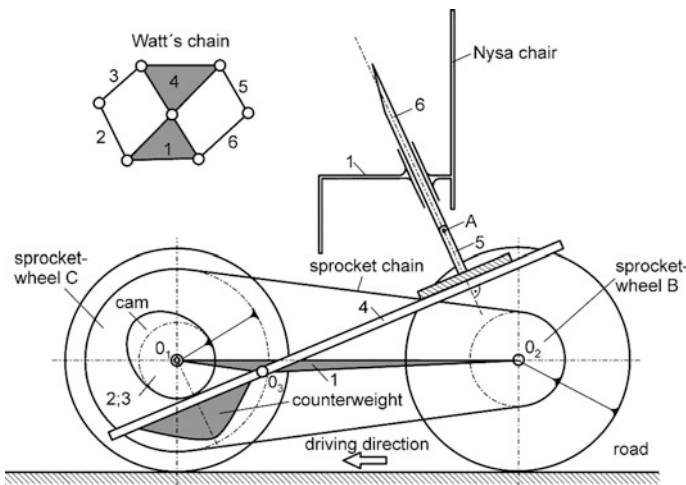
(see Fig. 16). Schramm’s catapults worked. He demonstrated them in Saalburg in 1904 in the presence of Kaiser Wilhelm II (Wilkins 2003, p. 24).

If Rehm is right with his reconstruction of the automatic snail (see Fig. 2b), a sprocket chain could also very well have been used in that machine in order to transmit the motion of the treadmill to the wheels.

In the next section, we offer, in some detail, two possible designs for the Nysa in which the motion of the wheels is slowed down. In the first one, two sprocket wheels and a chain slow down the motion (see Fig. 17). The input rotary motion is taken from a sprocket wheel which is fixed to the rear-axle of the cart. The rotary

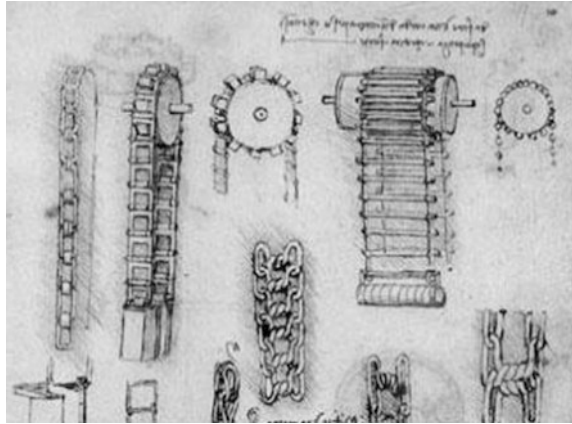


**Fig. 16** Catapults in the Saalberg Museum built by Erwin Schramm some time before 1904. Standing on the left is Dionysius’s repeating catapult with sprocket chain. The chain is shown once more at the bottom. *Source* <http://en.wikipedia.org/wiki/Polybolos>



**Fig. 17** Solution with sprocket chain and sprocket wheels

**Fig. 18** Sprocket chains in Da Vinci's *Codex Madrid* of 1493



motion is transmitted by means of a chain to a sprocket wheel that rotates freely on the axle of the front-wheels of the cart. A cam on this wheel operates the mechanism that lifts the Nysa. The second design is basically Lewis's. It uses two gear wheels to slow down the motion (see Fig. 18).

## 7 Presentation in Some Detail of Two Possible Mechanical Solutions for the Nysa Cart Mechanism

In the following section, two possible mechanical solutions are given for a mechanism that could move the Nysa statue upward (and downward) while the cart with the chair fixed on it drives on the road. Both solutions are kinematically based on a six-bar chain with links 1–6, also called Watt's chain. The mechanisms derived from this chain execute constrained motion with one degree of freedom.

Figure 17 shows a solution with one sprocket chain and two sprocket wheels B and C. The input rotary motion is taken from the sprocket wheel B (right side) which is fixed to the rear-wheel of the cart, both wheels having the common axis  $O_2$ . The rotary motion of wheel B is transmitted to sprocket wheel C by means of a sprocket chain. Sprocket wheel C (left side) rotates independent of the front-wheel of the cart because of a double rotary joint in  $O_1$ .

Now, the mechanism for lifting the Nysa statue starts with the fixed link or frame 1 carrying the two cart axles  $O_1$  and  $O_2$ . The Nysa chair is also part of link 1. Kinematically, the cam fixed to the sprocket wheel C around  $O_1$  represents the links 2 and 3 of the mechanism. The cam presses down the input part of the lever 4 which rotates around  $O_3$  in the frame, and thus moves link 5 upward, sliding on the output part of the lever and being coupled to link 6 via a turning pair in A. Link 6 slides in the chair 1 and moves the Nysa statue diagonally upward. A counterweight on the

input part of the lever can reduce the reaction force exerted on the cam. When the cart continues driving, the cam reaches its initial position again, and Nysa “sits down”. A proper choice of the diameter ratio of the two sprocket wheels serves to increase the mechanical advantage of the cart mechanism.

How did the ancients construct such a sprocket chain? We don’t really know, but Leonardo’s sketches in the Codex Madrid gave an idea of what an intelligent engineer imagines once the concept of a sprocket chain is born (see Fig. 18).

Figure 19 shows a solution based on two gearwheels B and C on axes  $O_2$  and  $O_4$ , respectively, both resting in the frame 1. Now, the diameter ratio of the two meshing gearwheels influences the torque transmission between the input gear-wheel B fixed to the rear-wheel on the road and the output link 6 sliding in the chair and moving the Nysa statue upward and downward. But moreover, this solution adds a turning component to link 5 when the lever 4 rotates around  $O_3$  in the frame. The rotation can now be used to pour milk or some other liquid out of the mouth of the Nysa statue. The rotation of the statue is coupled to its translation and essentially depends on the ratio of lengths  $O_3$ -D/D-A.

In the solution of Fig. 17, based on sprocket wheels and a sprocket chain, we have positioned the wheels in such a way that the whole mechanism is actually hidden behind the wheels. Other solutions are obviously possible. It is, for example, easy to replace the two gear wheels in Lewis’s solution with two sprocket wheels and a chain without radically changing the position of the two wheels.

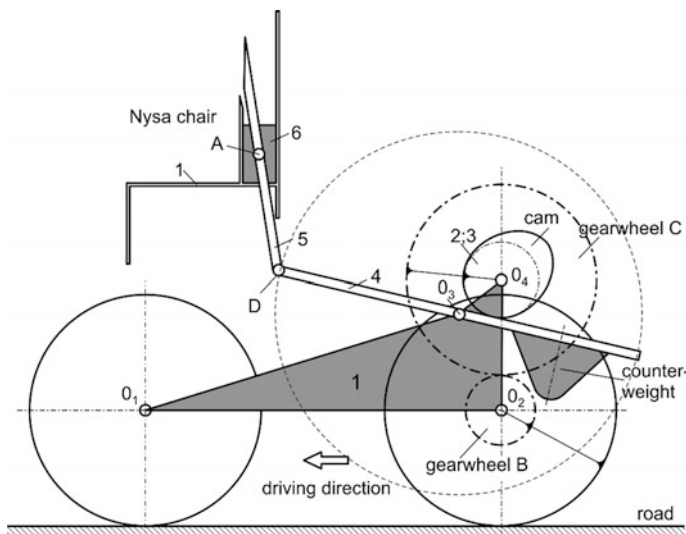


Fig. 19 Solution with gearwheels based on Michael Lewis’s design

## 8 How Was the Offering of Milk Poured?

We have not discussed the way in which the Nysa poured a libation of milk from a golden phiale or bowl when standing up. See Fig. 20 for an image illustrating what this was a reference to.

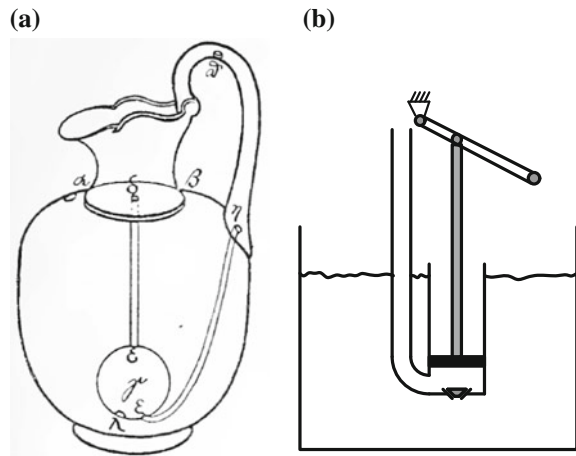
Rice suggested that it may have been an askos with a controlled opening (Rice 1983, p. 64). The question is, of course, how the opening was controlled. We know that Ktesibius, who may have designed the automaton, was a pioneer in flow rate control mechanisms. He designed, for example, a pump and a fire engine, which depended on the use of clapper valves to allow the fluid to flow in only one direction (Hodges 1970, p. 181). In Fig. 21b, we have the principle of Ktesinius's fire engine. See, for example, (Drachmann 1963, pp. 155–157). With a lever, the piston is moved up and down. When the piston moves downward, the valve is closed and the water is pushed upward. When the piston moves upward, the valve is open and water can enter into the cylinder.

It is, indeed, possible that inside the trunk of the Nysa was a reservoir connected to the bowl in the statue's hand. Inside the reservoir, there would then be a big reservoir and a small reservoir. The two reservoirs would be separated by a valve. The libation would exit through a tube from the small reservoir. When the Nysa was seated, the valve was open and milk flowed from the big reservoir into the small reservoir. When the Nysa got up, gravity and the weight of the milk closed the valve and the contents of the small reservoir were ritually poured as an offering to the Gods. This solution requires that the reservoir be turned during the standing up at an angle large enough to make it all happen. This would imply that the trunk of the Nysa was rotated while it stood up; it would exclude a translation. In his *Pneumatics*, Heron of Alexandria describes a can out of which the same quantity

**Fig. 20** Artemis pouring a libation from a phiale. Attic white-ground lekythos, ca. 460–450 BC (from Eretria)



**Fig. 21** **a** Heron's can out of which the same quantity always pours, *source* (Schmidt 1899, p. 211). **b** The principle of Ktesibius's pump



always flows when tilted (see Fig. 21a). The drawing is a reconstruction by Schmidt. The can is filled with a liquid through a hole that we close afterwards. The liquid also enters the small reservoir inside the can through the opening  $\lambda$ . When we tilt the can, the opening  $\vartheta$  in the handle allows air to come inside and the content of the small reservoir flows out. Such a trick vessel may have been used. Who knows?

There is another possibility, which seems to us more probable. If the procession lasted all day and the reservoir was not refilled underway, it must have been a big reservoir, which would make it necessary to position it lower than the bowl or askos from which the libation flowed. It is possible that whenever the Nysa stood up, the operator inside used a pump of the type invented by Ktesibius in order to push a quantity of milk upwards.

## 9 Conclusions

In this paper, we offered a number of possible designs for the mechanism by means of which the Nysa rose and sat down again automatically. We evaluated these designs taking into account the earliest occurrences that we know of in history of linkages, cogwheels, sprocket wheels and driving belts. Considering the designs, and taking the historical context into account, we concluded that the most probable design of the mechanism used to make the Nysa stand up and sit down made use of a cam and a lever. This is in accordance with what Rice (1983) suggested, but we made her proposal more detailed.

We think it is probable that a mechanism was used to slow down the motion. We considered two possible designs. The first possibility is that sprocket wheels and a chain were used to slow down the motion. The second possibility is that gear wheels were used. It is clear that both the concept of a sprocket chain and of gear

wheels were known in 3d century BC Alexandria. Moreover, we feel we should not underestimate the knowledge of the ancients. And yet, our proposals remain hypothetical.

Finally, we briefly discussed the way in which the ritual offering of milk might be brought about. It seems possible that use was made of a pump operated by someone inside the cart.

**Acknowledgements** We are grateful to the participants in the IFToMM Workshop on the history of mechanism and machine science on November 21–22, 2013 in Palermo, Italy, for critical comments on an earlier version of this paper. We are grateful to Michael Wright for a stimulating discussion of the problem. We also thank Thekla Rörmann for drawing Figs. 17 and 19.

## References

- Al-Jazari (1979) *Al-Jami bayn al'ilm wa al-amal al-nafi fi sina at al-hiyal* (A compendium on the theory and practice of the mechanical arts). In Al-Hassan AY (ed) *Institute for the History of Arabic Science*. University of Aleppo, Aleppo
- Austin RG (1959) Virgil and the wooden horse. *J Rom Stud* 49(Parts 1 and 2):16–25
- Coleman KM (1996) Ptolemy Philadelphus and the Roman Amphitheater. In: Slater W (ed), pp 49–68
- Drachmann AG (1963) *The mechanical technology of Greek and Roman antiquity*. Munksgaard, Copenhagen
- Farmer HG (1931) *The organ of the ancients from eastern sources* (Hebrew, Syriac and Arabic). London
- Fraser PM (1972) *Ptolemaic Alexandria*, vols 3. Clarendon Press, Oxford
- Freeth T et al (2006) Decoding the ancient Greek astronomical calculator known as the Antikythera Mechanism. *Nature* 30:587–591
- Gille B (1954) *La came et sa découverte*. *Techniques et civilizations*, pp 8–9
- Goehring JA (1997) *Alexandria in Late Antiquity: topography and social conflict.*, Ancient society and history series Johns Hopkins University, Baltimore
- Hodges H (1970) *Technology in the ancient world*, Allen Lane. The Penguin Press, London
- Koetsier T (2001) On the prehistory of programmable machines: musical automata, looms, calculators. *Mech Mach Theory* 31:589–603
- Koetsier T (2009) Phases in the Unraveling of the secrets of the gear system of the Antikythera mechanism. In: Yan H-S, Ceccarelli M (eds) *International symposium on history of machines and mechanisms—proceedings of HMM 2008*. Springer, pp 269–294
- Lewis MJ (1997) *Millstone and Hammer: the origins of water-power*. University of Hull Press, UK
- Needham J (1965) *Science and civilization*, Vol IV: 2. Cambridge University Press, Cambridge
- Oleson JP (ed) (2008) *The Oxford handbook of engineering and technology in the classical world*. Oxford University Press, Oxford
- Rehm A (1937) Antike automobile. *Philologus* 317:317–330
- Rice EE (1983) *The grand procession of Ptolemy Philadelphus*. Oxford University Press, Oxford
- Ritti T, Grewe K, Kessener P (2007) A relief of a water-powered stone saw mill on a sarcophagus at Hierapolis and its implications. *J Rom Archaeol* 20:139–163
- Schmidt W (1899) (Herausgeber), *Hérons von Alexandria Druckwerke und Automatentheater*. B. G. Teubner, Leipzig
- Schramm E (1918) *Die antiken Geschütze der Saalburg, Bemerkungen zu ihrer Rekonstruktion*. Neubearbeitung der Schrift “Griechisch-römische Geschütze”, Berlin

- Slater WS (ed) (1996) Roman theater and society: E. Togo Salmon paper I. University of Michigan, Michigan
- Soedel W, Foley V (1979) Ancient catapults. *Sci Am* 150–160. See <http://www.mlahanas.de/Greeks/war/Catapults.htm>
- White Jr L(1964) *Medieval technology and social change*. Oxford University Press, London
- Wilkins A (2003) *Roman artillery*. Shire Publications Ltd, Oxford
- Wilson Andrew (2002) Machines, power and the ancient economy. *J Rom Stud* 92:1–32

# Hindu Temple Carts—Rathams

J.S. Rao, Babaji Raja Bhonsle and Bigil Kumar

**Abstract** Hindu Temples from ancient times used Carts (*Rathams* or *Thers*) to bring out Deities in procession on festival days. The origin of these carts and their construction is discussed in this paper, together with current design practices befitting the changing times.

## 1 Vedic Period

Hindu temples have their origins in the Rig-Veda times, a period not exactly identifiable through modern historical dating methods, but derived from inference as having taken place at least 4000 years ago. The dates of the Stone Age vary considerably for different parts of the world. The Stone Age has been divided into three periods: the Paleolithic, the Mesolithic, and the Neolithic (see Technology of Man 1979). Throughout the immense time span of the Stone Age (see Scarre 1988; Schick and Nicholas 1993), vast changes occurred in the climate and in other conditions affecting human culture.

The Paleolithic, or Old Stone Age, was the longest era. It began about 2 million years ago, when stone tools were first used by humanoid creatures, and ended with the close of the last ice age around 13,000 BC. After 13,000 BC, more clement weather patterns resulted in a greater availability of food. This time period coincides with the description of the epic Hindu story Ramayana, followed by the Mahabharata. This is about five centuries earlier than Mesopotamian civilization.

---

J.S. Rao (✉)  
Kumaraguru College of Technology, Coimbatore, India  
e-mail: jsrao@kct.ac.in

B.R. Bhonsle  
Hereditary Trustee Thanjavur Palace Devasthanam, Thanjavur, India

B. Kumar  
Virtual Validation, Pricol Technologies Ltd, Coimbatore, India



The epic Ramayana contains descriptions of battles with incredible weapons cited as the Brahma weapons (Brahma Asthra).

The Gāyatrī Mantra is a highly revered mantra based on a Vedic Sanskrit verse from a hymn of the Rig-Veda (3.62.10), attributed to the rishi (sage) Viśvāmitra (see Griffith 1890).

ॐ भूरभुवः स्वः ।

तत्सवितुर्वरेण्यं ।

भृगो देवस्य धीमहि ।

धियो यो नः प्रचोदयात् ॥ ।

This is the 16th stanza of the Upanishads, a sacred text, in Devanagari script; a translation into English, such as that offered by celebrated translator Easwaran (2007), would be, “O nourishing Sun, solitary traveler, controller, source of life for all creatures, spread your light and subdue your dazzling splendor so that I may see your blessed Self. Even that very Self am I!”

According to the great soul Mahatma Gandhi, “If all the Upanishads and all the other Scriptures happened all of a sudden to be reduced to ashes, and if only the first verse in the Ishopanishad were left in the memory of the Hindus, Hinduism would live forever”. He is referring to the memory power of Hindus, which is responsible for having passed Vedas down from generation to generation over thousands of years.

In traditional Brahmin practice, the Gayatri Mantra is addressed to God as the divine life-giver, symbolized by Savitr (the Sun), and is most often recited at sunrise and sunset. It is believed by practitioners that reciting the mantra bestows wisdom and enlightenment, through the vehicle of the Sun (Savitr), who represents the source and inspiration of the universe (see Radhakrishnan 1947).

The Vedas have been transmitted orally down through the ages, with surprising accuracy, as if they have been recorded by entire families of Brahmins across India. Since they are so perfectly preserved, linguists are able to date them as being from at least 1500 BC. The Rig-Veda records battles amongst the various nomadic tribes known as the Aryans. Jones (1824) on February 2nd, 1786, addressed the Asiatic Society of Bengal about the origin of Sanskrit, a language having much in common with Latin and Greek; commonly used words are shown below for Father, Mother and Horse.

Sanskrit	Latin	Greek
<i>Pitar</i>	<i>Pater</i>	<i>Pater</i>
<i>Matar</i>	<i>Mater</i>	<i>Meter</i>
<i>Aszwa</i>	<i>Asva</i>	

The Ramayana refers to certain Vedic Gods, like Indra, Agni and Varuna, among others (see Didhiti Biswas article in Dodiya 2001). Indra was the God of Thunder and Rain; he dropped down with the water from sky in chariots drawn by

horses. A key part of society in the Rig-Veda era was the taming of horses in a very early period, and the text mentions migrations eastward along rivers identified from the Afghan border, the Swat River being mentioned in Rig Veda 8.19.37 as the Suvastu River. The Rig-Veda and the life of ancient Indians during that period have been described by Srinivasa Iyengar (1912). The book describes the daily practices and the Rig-Vedic Gods descending from the sky. Though Jones suggests the external entry of Aryans into India through linguistic connections, others disagree, and there is a strong debate about Indo-Aryan invasions (see Shaffer 1984). Nevertheless, Rig Vedic data must be used, if cautiously, as they are the earliest available textual evidence of what occurred in this period.

## 2 The Mohenjo-Daro Mystery

In 1922, Rakhaldas Bandyopadhyay, an officer of the Archaeological Survey of India, discovered the Indus valley civilizations at Mohenjo-Daro (Mound of the Dead) and Harappa. He was led to the mound by a Buddhist monk, who believed it to be a stupa. In the 1930s, massive excavations were conducted under the leadership of John Marshall, K.N. Dikshit, Ernest Mackay, and others. At the International Conference on Harappan Archaeology in November 2012, archaeologists B.R. Mani and K.N. Dikshit, both of the Archaeological Survey of India, claimed that new dates from excavations show the Harappan culture began around 2000 years earlier than previously believed (see Pasthorizons adventures in archaeology 2012). Kenoyer (1996) earlier noted that the earliest urban society in South Asia is represented by the small networks of cities and towns around 3300–2600 BC, with a major expansion seen taking place from 2600 to 1900 BC. The settlements around the Indus were placed as existing around 3750 BC.

At this site, 37 skeletons were found in contorted positions, in a residential district of the town (see Fig. 1). No single body was found within the fortified citadel, disproving the theory that there was battle and massacre that followed. Six other skeletons were found in a lane between two houses covered with loose earth, free from bricks and any other debris, and not indicative of any violent death in a battle. There is one more fragmentary skeleton with a part of the skull, thorax and the upper arm of an adult. In all, there were 44 skeletons found at this site.

At the time of Mohenjo-Daro, mankind had not known an atomic weapon. No conventional weapons, such as swords or spears, were found. No scavenging animals or their skeletons were discovered at this site, just 44 human skeletons. This is despite the well-recorded and well understood destruction of the city of Pompeii after the eruption of Mount Vesuvius in 79 AD (see De Carolis and Patricelli 2003). Just as the battles described in the Hindu epics Ramayana and Mahabharata were completely ignored, here, too, in Mohenjo-Daro, were the mysterious circumstances discounted.



**Fig. 1** Skeletons at Mohenjo-Daro attributed to Massacre theory

### **3 The Trinity Test and After**

The first atomic bomb was detonated on July 16, 1945, at the Trinity test in New Mexico; its creator, Oppenheimer (1965), remarked later, “We knew the world would not be the same. A few people laughed, a few people cried, most people were silent. I remembered the line from the Hindu scripture, the Bhagavad-Gita. Vishnu is trying to persuade the Prince (Arjuna) that he should do his duty and to impress him takes on his multi-armed form and says, Now, I am become Death, the destroyer of worlds.”

After the Trinity test, in the 1940s and ‘50s, archaeologists from Great Britain, India and Pakistan revisited the sites of the Indus valley civilizations at Mohenjo-Daro and Harappa, located close to the India-Pakistan border. According to Dales (1964), the evidence given earlier suggested that Mohenjo-Daro was destroyed by armed invaders and that the hapless victims were massacred on the spot. This was a quick conclusion drawn because evidence of a classical example of an authentic natural disaster, such as the eruption of Mount Vesuvius in Pompeii in 79 AD, was not present.

A serious obstacle in determining the cause of the destruction at Mohenjo-Daro is the inability to solidify the chronological events in South Asia, particularly the end of the Indus civilization and beginning of Aryan influence. There was no evidence for a large invasion, e.g., as per Dales, the complete absence of burnt

fortresses, arrow heads, smashed chariots, etc. Marshall (1931), the first director of the investigations, attributed this absence to slayings by bandits from the hills to the west.

Suggestions were made that this might be the site where the epic battles of the Ramayana took place; however, conventional science did not support this possibility in the absence of any evidence. The Ramayana describes how, in the battle in which the Brahma Astra was used, generating a brightness of more than 1000 Suns, trees went up in flames; more significantly, the epic describes people who survived the battle as losing their hair and having their nails start to fall out—typical effects of radiation observed after the present day atomic explosions (see Tsoukalos 2012). Childress (2012) discusses Vimanika Sastras (flying machine technologies) described 6000 years ago in Sanskrit texts, indicating that this technology existed in the olden days. The texts describe three giant cities orbiting the earth, with gleaming metal and iron, going to war with each other. Tsoukalos and others are proponents of the idea that ancient astronauts interacted with ancient humans. What is it our ancestors are describing in the ancient Sanskrit scripts? Some type of technology that was witnessed? They didn't understand the nuts and bolts aspects of this technology, yet they created divine representations; the practices that they have developed are so effective, they remain in force in India even today.

Basham (1977) wrote his book in the early 1950s, subscribing to the Aryan invasion theory, but a lot has changed subsequently. The decline of the Harappan civilization is no longer attributed to invading Aryans.

There is another strong factor associated with the epics written in this period, and it points to some mysterious events in the wars described, which, unfortunately, do not stand up to scrutiny in regard to the present scientific methods. The Rig-Veda, the earliest book known in India, describes the principal God, Indra, as the fort destroyer, rending forts in the way age consumes a garment. He is attributed with setting fire to the buildings and burning all the enemy's weapons so as to make himself rich with kine and carts and horses. It describes the armor and shields used for protection; in addition to the bow and arrow, javelins, axes and swords are used. Wheeler (1968) surmises that Indra stands accused of destroying the Harappan civilization.

Davenport (1979) spent 12 years studying at the site; according to him, Mohenjo-Daro corresponds exactly to Nagasaki. An epicenter about 50 yards wide was found where everything was crystallized, fused or melted. Sixty yards from the center, the bricks are melted on one side, indicating a blast. He cites the Mahabharata, "White hot smoke that was a thousand times brighter than the sun rose in infinite brilliance and reduced the city to ashes. Water boiled... horses and war chariots were burned by the thousands, the corpses of the fallen were mutilated by the terrible heat so that they no longer looked like human beings..." He also notes that the skeletons at the site have not decayed, and there were no suggestions of wild animals having scavenged on them. At this site, even today, the radiation levels are high, suggesting that there was an atomic attack (see History Channel Video 2012).

It is reported that the radiation levels at the site are higher than normal. Huge masses of walls and foundations of the ancient city are fused together, literally vitrified! And since there is no indication of a volcanic eruption at Mohenjo-Daro or at the other cities, the intense heat needed to melt clay vessels can only be explained by an atomic blast or some other unknown weapon. The cities were wiped out entirely.

Scientists B.R. Mani and K.N. Dikshit of the Archaeological Survey of India (ASI) reported their latest research on excavations carried out at two sites in Pakistan and Bhirrana, Kunal, Rakhigarhi and Baror in India from which the origin of the Indus Valley Civilization emerged in the 8th millennium BC in the Ghaggar-Hakra and Baluchistan areas (see Khandekar 2012). Their findings are based on radio-metric dates from Bhirrana (Haryana).

Some have attempted to connect certain unexplainable observations at the Mohenjo-Daro and Harappan excavations to Vedic practices and events described in the mythological documents of the Ramayana. Chariots have been described from Vedic and more recent times, popularly known as *Thers*, as being used on an almost annual basis to take out Gods in a procession for Hindu devotees. These *Thers* existed for over a thousand years, first in stone and later in movable form; they are designed and built according to Shastras (or Vedic rules) and still used in the present day.

#### 4 Hindu Temples and Chariots (*Rathams* or *Thers*)

The Rig Veda cites chariots in many places: The chariot carrying the God is moving through the air with very swift motion (Rig Veda V.77.3). It is hard to overtake (Rig Veda.V.35.7).

The Chariot's greatness is praised (Rig Veda.X.75.9). In several verses, the honorableness is explicitly mentioned (Rig Veda X.41.1.2; X.168.1). The chariot itself is divine (Rig Veda IX.111.3); and worthy of veneration and oblation (Rig Veda VI.47.27-28) (see Griffith 1890). Individual parts of a *Ratha* are mentioned in Vedas: *Aksa*: The axle of the chariot, Rig Veda 1.30.14; *Aksu*: Axle of a chariot, Rig Veda.1.80.5; *Kha*: Hollow, aperture, a hole in the nave of a chariot wheel, Rig Veda VIII.77.3; Lubrication of the nave, Rig Veda X.156.3, *Nabhi*: Nave of a chariot, Rig Veda X.78.4; VIII.41.6V.43.8, *Cakra*: The wheel, Rig Veda I.155.6.

Hinduism, somewhat overshadowed by 700 years of dominance by Buddhism and Jainism, became prominent in the 4th century with the rise of the Gupta rulers. Many elements of this revival were common with the religion of the Aryans (e.g., the importance of the Vedas); the Aryan element gods (such as Indra and Agni) were replaced by two main deities, Shiva and Vishnu, each of whom had a multitude of forms or incarnations, as well as consorts, allowing local deities and cults to be appropriated into the Hindu pantheon. The method of worship changed from open-air sacrificial altars to viewing the deity, called darshana, in a confined sanctum. The Guptas patronized this religion and sponsored temples to Vishnu and

Shiva from the beginning of the 5th century AD. The temple and idol worship was promoted with the development of temple architecture between the 6th and 16th centuries, especially in South India, by kings and wealthy men. The oldest Hindu temple functioning today is the Mundesvari Temple at Kaura in Bihar, shown in Fig. 2, its construction dated to 108 AD (see Bhat 2010).

The Pallavas (600–900 AD) are amongst the earlier patrons to sponsor the building of the rock-cut chariot-shaped temples of Mahabalipuram, including the famous shore temple, and the Kailashnath and Vaikuntha Perumal temples in Kancheepuram. The monolithic temples in Mahabalipuram are known locally as *Ratha* (Chariot) and the gopurams (superstructure) are called *Vimanas*. Figure 3 shows five *Rathas* originally meant for Lord Vishnu, Shiva and Parvati, but renamed in order of their size, *Dharma raja Ratha*, *Bhima Ratha*, *Arjuna Ratha*, *Nakula Sahadeva Ratha*, and *Draupadi Ratha*, although they have no link to the iconic characters of the Mahabharata epic.

The Pallavas style further flourished—with the structures growing in stature and sculptures becoming more ornate and intricate—during the rule of the dynasties that followed, particularly the Cholas (900–1200 AD), the Pandyas (1216–1345 AD), the Vijayanagaras (1350–1565 AD) and the Nayaks (1600–1750 AD).

During the Chola period, the South Indian style of building temples reached its pinnacle, as exhibited by the imposing structures of the Tanjore temples, amongst them, the Brihadeshvara Temple (1009 AD) (Fig. 4a). In this ancient temple, an elaborate mural is present on the northern wall, as shown in Fig. 4b (see Mohamed



**Fig. 2** Mundesvari Devi temple at Kaura in Bihar (108 AD)

**Fig. 3** Five *Rathas* of Mamallapuram (Mahabalipuram) (630–638 AD)



and Iqbal 2010). Here, Lord Siva appears as Tirupurantaka on his chariot, with his eight arms wielding different weapons. The charioteer is Lord Brahma himself. The *Ther* is Earth itself, with the Sun and Moon playing the part of the wheels. Nandi, Siva's vahana, is pulling the chariot. Brahma the charioteer appears to be smiling at Lord Siva, who claims to be the destroyer, observing his inability to destroy the three asuras, or demons, with his bow and arrow. This is also being closely watched by other Gods riding on their own vehicles. Siva, observing Brahma's smile, turns the bow backwards and opens his third eye to destroy the asuras. This mural recalls what our ancestors saw during the Rig-Veda and Ramayana periods. This is the grandest creation of the Chola emperor Rajaraja (AD 985-1012).

This mural clue is taken from Vikrama Chola (1117–1135 AD), who built the first temple in Thukkachi with a wheel (see Fig. 5a). This was followed by Rajaraja Chola II, who built the Airavatesvara temple (1146 AD) (see Fig. 5b), which has a horse-drawn chariot carved onto the front of the mandapam. The chariot and its wheel are so finely sculpted that they include even the faintest details. Chariots figure prominently in the Rig-Veda, with Rig Vedic deities, notably Ushas (the dawn), riding in a chariot, as well as Agni in his function as a messenger between Gods and men. Airavatesvara is the first temple to rest on spoked chariot wheels drawn by horses. It appears that the Cholas, over a thousand years ago, were projecting Gods in *Thers* just as our ancestors saw in the Rig-Vedic and Ramayana periods. This trend followed in the towns of Konark and Hampi.

The Lingaraja Temple (Fig. 6) is believed to have been built by the Somavanshi King Jajati Keshari in the 11th century, and is one of the oldest temples in Bhubaneswar, the capital of the East Indian state of Odisha.



**Fig. 4** a Brihadeshvara temple. b Destruction of the Demons by Lord Siva as Tirupurantaka on his chariot with his eight arms





**Fig. 5** a First temple with a Wheel (1117–1135 AD). b Airavatesvara temple and spoked chariot wheel



**Fig. 6** Lingaraja temple in Odisha (11th Century)



**Fig. 7** Konark Sun Temple

Like the Brihadeshvara and Airavatesvara temples in the Thanjavur area, the Konark Sun Temple (1278 AD) follows the Lingaraja Temple in Odisha; it was conceived as a gigantic chariot of the Sun God, with twelve pairs of exquisitely ornamented wheels pulled by seven horses. Figure 7 shows one of these wheels.

As mentioned earlier, our ancestors attempted to describe in the ancient Sanskrit scripts some type of technology that they had witnessed, attributing it to divine representation, in practices so effective, they remained in force through later times, even up to the present day in India. So it appears that the Guptas in the North and the Chalukyas in the South brought the worship of Gods from open-air sacrificial altars to viewing the deity called darshana in confined sanctums, i.e., temples.

The next step seems to have been putting the Gods as they are known in the scriptures on flying chariots (Fig. 8), as depicted by the History Channel, rather than keeping them in confined places, and the best way to do this was to repurpose the temple structures, calling their superstructures vimanas and fitting them with wheels so they might be chariots to carry the Gods. The construction of the Airavatesvara and Konark temples depicts the chariot style with wheels.

The Rig-Veda also describes battles using Vimanas (Fig. 9), as depicted on the History Channel and best described by our ancestors; this is the reason why the superstructures of temples are called Vimanas.



**Fig. 8** Battles from flying chariots



**Fig. 9** Vedic Battles in the sky from Vimanas

**Fig. 10** Konark Temple Chariot (1278 AD)



Stone chariots were built at Konark (1278 AD) (see Fig. 10). The Vijayanagara Kings built several temples in Hampi and one stone chariot at the Vittala Temple in the 16th century (see Fig. 11). The wheels of this *Ratha* can be rotated, but they were cemented to avoid the damage caused by visitors.

**Fig. 11** Stone chariot in Hampi (16th century)

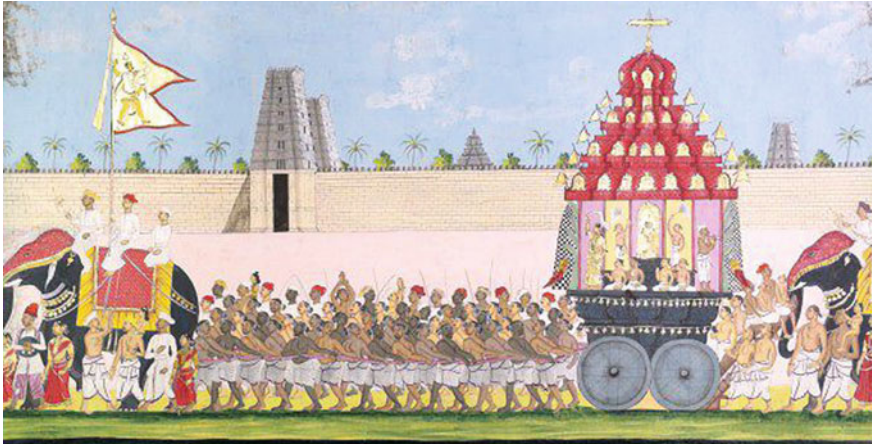


## 5 Chariots and Procession

It is difficult to date when the practice of chariots carrying Gods on festival days began; it was probably during the Vijayanagara period in the 16th century. First, the temples were built to honor the puranic Gods, and then the temples were identified as *Vimanas* on one hand and *Rathas* or Chariots on the other hand, to identify the Gods as noted in Vedic and Ramayana periods. In the 16th century, they were brought out on festival days for a public darshana, thus the culture of temple chariots, or *Rathams* or *Thers*. The *Ther* itself is considered to be the manifestation of a temple housing a God. Those pulling the *Ther* consider themselves to be rewarded by divine blessing. In today's practice, Rathotsava is an important social gathering, enhancing living in harmony. An ancient Rathotsava is depicted in Fig. 12, showing a view of a temple car being drawn in procession outside the Vaisnavite temple of Ranganatha at Srirangam, near Tiruchirapalli. The event is part of the celebration of the annual festival. Devotees install portable images of the presiding deity—Vishnu, and his consorts, the goddesses Sri Devi and Bhu Devi—in a great chariot or Temple *Ratha* and draw them around the temple streets. The painting shown originates from Thanjavur in 1800 (see Dallapiccola 2010).

From the above, it is reasonable to surmise the following. Our ancestors during the Rig-Veda and Ramayana periods perhaps witnessed cultures apart from their own, maybe aliens in orbiting vehicles, and found ways of transmitting this information through recitation, a form which exists even today. The destruction they witnessed somewhat resembles today's world and what Lord Krishna told Prince Arjuna was recollected by Dr. Oppenheimer soon after the Trinity test. It can reasonably be considered that the Brahma weapon described in Ramayana is similar to the current atomic bomb, which we witnessed in use first at the Trinity test and twice during World War II in Japan.

The Vedas, Ramayana and Mahabharata are probably the documents they left in recitation form in absence of a writing process. These memories, so powerful and



**Fig. 12** Ancient Rathotsava and procession

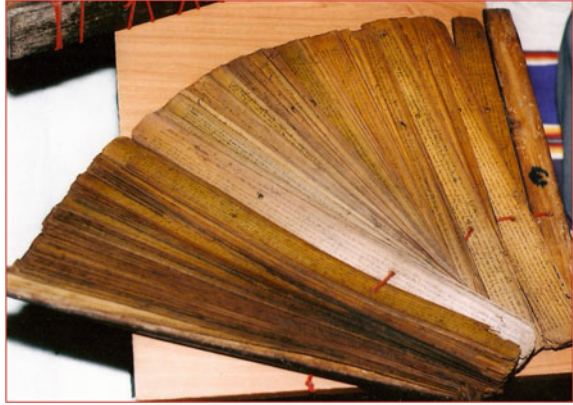
passed from generation to generation through recitation, were first manifested in temples where Gods were placed, and then the subsequent renovation of the temples to resemble the vimanas or *Rathams*, first by naming them so and then by placing the wheels and horses to make these temples resemble chariots; these were subsequently converted during the Vijayanagara empire into *Rathas* to take the Gods out in a procession on important days and display them to people, so as to resemble what had been seen a few thousand years ago as closely as possible. The East India Company witnessed these processions and employed painters to paint them, as we can see in the one above originating from Thanjavur in 1800.

As noted earlier, the chariots have their origins in the Rig-Veda period; a special section of Vedas deal with the construction of temples and *Rathas*. Silpa Sastra deals with *Ther* construction (Maha Viswakarmiyam), a description of which was put on palm leaves between the 8 and 10th centuries AD, as shown in Fig. 13 (see Umaphy 2013). The translation of Leaf 801 in Sanskrit, shown in Fig. 14, details different varieties of *Ratha*.

Shastras (Rules) to design the *Thers* were probably developed as early as the 8th century AD. They are: (1) Viswakarma Rathalaksanam, (2) Kumara Tantra, (3) Maha Viswakarmiyam and (4) Karanagama. These materials can also be found in printed texts, Acharya (1934a, b) and Mankad (1950).

In general, a *Ther* should have a *Simmasanam* (Crown Chair) for the Deity, a *Devasanam* (Seat of Devas), a *Narasanam* (Seat for priests), and different *Boothabars* from which the Crown Chair is reached (see Fig. 15). A view of such a typical *Ther* is shown in Fig. 16.

**Fig. 13** Silpa Sastra on Palm leaves



**Fig. 14** Translation of Palm Leaf 801 of Silpa Sastra

801

हारागे औधिकायुक्तं मुष्टिबन्धमथ शृणु ।  
 भानोऽर्धे उपधानं स्यात् उपपीठं त्रिघान्वितम् ॥ 40  
 ऊर्ध्वं धं कृतधो पदं अन्नपङ्क्तिभिरावृतम् ।  
 गजपङ्क्तिभिरावृत्य भूतपङ्क्तिभिरावृतम् ॥ 41  
 श्रीकरं विजयं कान्तं श्रीकैक्य विशालकम् ।  
 श्रीभद्रं श्रीविशालं तु पद्मषड्रसकं शिवम् ॥ 42  
 इत्येते दृश निर्मानि तद्देदं तु वदाम्यहम् ।  
 अक्षौ त्वादि स्थप्यन्तं द्विगुणान्तनुमुच्यते ॥ 43  
 त्रिगुणाद्याधिकं तत्र षाकद्वित्रिक्रमं तु वा ।  
 यथा शोभार्थमित्येते रथानां च विशेषतः ॥ 44

The *Ther* has a superstructure like a vimana (see Fig. 17), but this is not essentially a load-bearing structure, being covered in decorations befitting a festive mood. Notice that these *Thers* do not have any steering or braking systems. The *Thers* are pulled by devotees and, being very heavy (about 300 tons in the case of the Tiruvarur temple), move inch by inch. Steering is achieved by using wedges placed by trained volunteers. The state of Tamilnadu alone has nearly 500 such *Thers* in different temples; each of these *Thers* cost around \$600,000 (US).

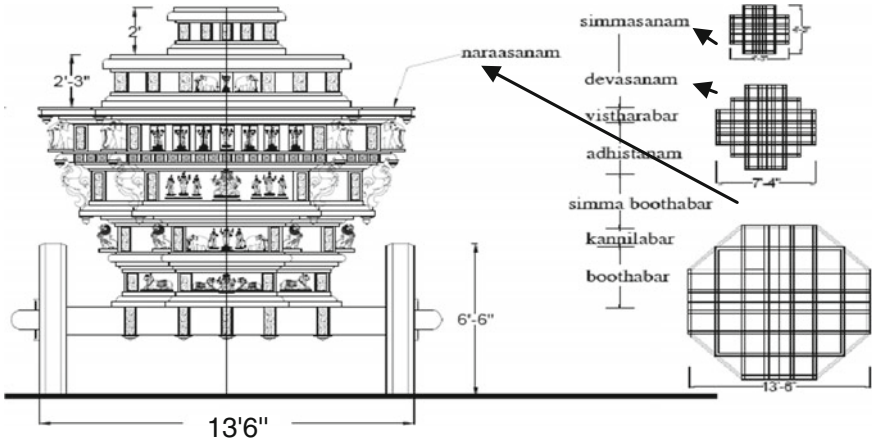


Fig. 15 A typical temple *Ratham* (Car)



Fig. 16 Temple car base



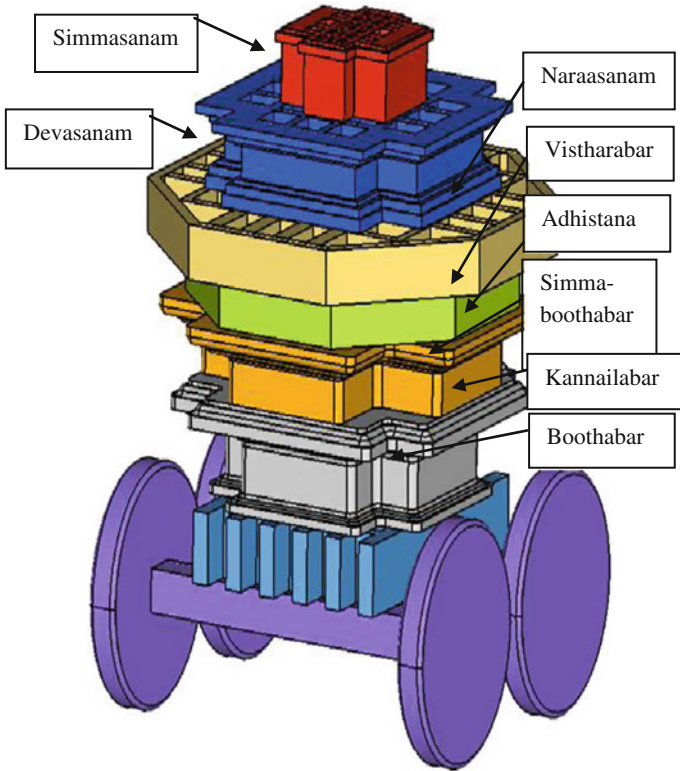


**Fig. 17** Thyagarajaswamy's temple car in Tiruvarur weighing 300 tons

## 6 *Ther* Structure Analyzed

Typically, the *Thers* are designed without the application of any structural mechanics principles; they tend to be satisfied with existing procedures based on traditions [AU: Nice as this sounds, it doesn't seem like 'happy' would be the right word]. Here, a typical *Ther*, as shown in Fig. 15, designed per the Vedic principles, is analyzed using modern finite element methods to understand how the designs following ancient principles fare.

A CAD model of the *Ther* shown in Fig. 15 is made and shown in Fig. 18. The *Ther* is made of Madhuca Latifolia wood, with  $G_{11} = 23800$  MPa,  $G_{22} = G_{23} = 238$  MPa and Density =  $9.2 \times 10^{-10}$  ton/mm<sup>3</sup>.



**Fig. 18** CAD model of a typical *Ther*

Figure 19a gives the overall dimensions in mm. The overlapping of each section is merged together in the model, i.e., no bolts are represented. The superstructure or vimana or gopuram mass is taken to be 60 tons and applied as shown in Fig. 19b. The gravity load is taken to be  $9810 \text{ N/mm}^3$ . Tet mesh is used and the boundary conditions are as shown in Fig. 19. The weight of the *Ther* is found from the CAD model to be 20 tons.

As per the Vedic traditions and practices, and without any analysis, the structure of the *Ther* has maximum deflection at Simmasanam, as in Fig. 20a, and the maximum principal stress is on the axle bars, as shown in Fig. 20b.

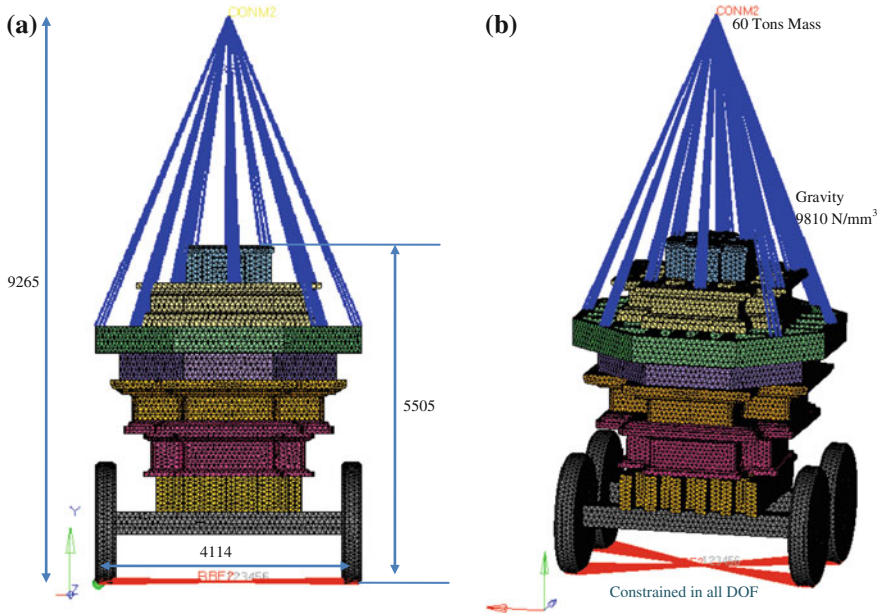


Fig. 19 a Tet Mesh FE model of the Ther with overall dimensions. b Tet Mesh FE model of the Ther with loads

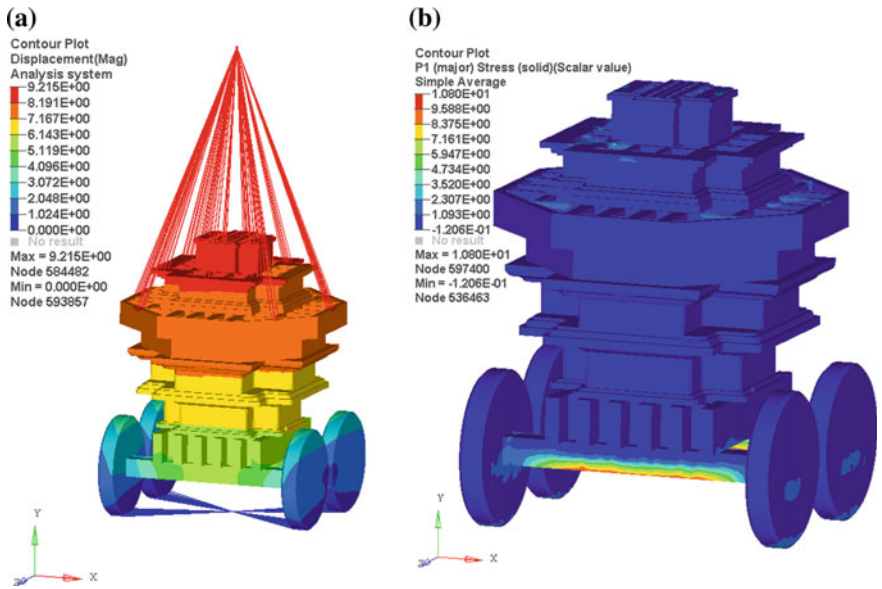


Fig. 20 a Maximum deflection locations. b Maximum principal stress locations

## 7 Conclusion

The origin of temples and *Thers* is traced back from Rig-Veda times. The *Thers* designed by Vedic rules appear to be good structures, according to modern finite element analysis.

**Acknowledgements** The authors are grateful to Chairman Padmabhushan, Dr. Mahalingam of Kumaraguru College of Technology and Chief Executive Officer Mr. Bobby John of Pricol Technologies, Coimbatore for their support in this work.

## References

- Acharya PK (1934a) Manasara vol III. DK Publishers, New Delhi, pp 286–292. ISBN 81-86142-71-1
- Acharya PK (1934b) Manasara vol V. DK Publishers, New Delhi. ISBN 7536-136-0
- Acharya U (2013) Family collection. Kumbakonam, India
- Basham AL (1977) The wonder that was India; a survey of the culture of the indian sub-continent before the coming of the muslims, 21st edn. Evergreen, Malaysia
- Bhat D (2010) The oldest temple in India. The Navhind Times, India
- Chandran T (2013) Sri Balaji Architech
- Childress D (2012) Ancient Hindu technology by history channel 2. <http://www.youtube.com/watch?v=yT7FRbstJCI>
- Dales GF (1964) The mythical massacre at mohenjo-daro. Expedition 6:36
- Dallapiccola AL (2010) South Indian Paintings, a catalogue of British Museum Collection. British Museum Press. <http://collections.vam.ac.uk/item/O68238/procession-with-festival-car-painting-unknown/>
- Davenport DW, Vincenti E (1979) 2000 a.C., distruzione atomica. SugarCo, Milan
- De Carolis E, Patricelli G (2003) Vesuvius, A.D. 79: the destruction of Pompeii and Herculaneum. L'erma Di Bretschneider, Roma
- Dodiya JK (ed) (2001) Critical perspectives of ramayana. Sarup and Sons, New Delhi
- Easwaran E (2007) The Upanishads. The Blue Mountain Center of Meditation, Tomales
- Griffith RTH (1890) The hymns of the Rig-Veda. E.J. Lazarus
- Jones Sir W (1824) Discourses delivered before the Asiatic Society: and miscellaneous papers, on the religion, poetry, literature, etc., of the nations of India. Printed for C. S. Arnold, p 28
- Karanagama (MS.No:T1035Aa), Palm leaf documents in French Institute of Pondicherry, Pondicherry
- Kenoyer JM (1996) Craft traditions of the indus civilization and their legacy in Modern Pakistan. Lahore Museum Bulletin IX(2)
- Khandekar N (2012) Indus valley 2000 years older than thought. Hindustan Times New Delhi, New Delhi
- Kumara Tantra: (MS.No:T0472), Palm leaf documents in French Institute of Pondicherry, Pondicherry
- Maha Viswakarmiyam: (MS.NoT167), Palm leaf documents in French Institute of Pondicherry, Pondicherry
- Mankad PA (ed) (1950) Aparajitaprccha, Gaekwad's Oriental series: 115. Oriental Institute, Baroda
- Marshall J (1931) Mohenjo-daro and the Indus Civilization.... A. Probsthain, London
- Mohamed IK, Iqbal A (2010) Vibrant at 1000 big temple, Thanjavur, India. Productivity and Quality Publishing, Chennai

- Oppenheimer JR (1965) <http://www.atomicarchive.com/Movies/Movie8.shtml>
- Pasthorizons adventures in archaeology (2012) Is the Harappan Civilisation 2000 years older? <http://www.pasthorizonspr.com/index.php/archives/11/2012/is-the-harappan-civilisation-2000-years-older> November 14
- Radhakrishnan S (1947) Religion and society. George Allen and Unwin Ltd., London
- Scarre C (ed) (1988) Past worlds: The times atlas of archaeology. Times Books, New York
- Schick KD, Nicholas T (1993) Making silent stones speak: human evolution and the dawn of technology. Simon & Schuster, New York
- Shaffer JG (1984) The Indo-Aryan invasions: cultural myth and archaeological reality. In: Lukacs JR (ed) The people of South Asia: the biological anthropology of India, Pakistan and Nepal. Plenum Press, New York
- Srinivasa Iyengar PT (1912) Life in ancient India in the age of mantras, Srinivasa Varadachari & co., Madras; original from University of California, California
- Technology of Man (1979) United Technologies Corporation
- Tsoukalos G (2012) In ancient Hindu technology by history channel. [www.youtube.com/watch?v=BCb40zQb5rc](http://www.youtube.com/watch?v=BCb40zQb5rc)
- Viswakarma Rathalaksanam: MS.No:11066, Saraswati Mahal Library, Thanjavur V&A Collection (1800), Museum number: AL.8806
- Wheeler REM (1968) The Indus Civilization, Cambridge history of India. Cambridge University Press, Cambridge

# Robots: An Evolving Species

Alberto Rovetta and Vincenzo Iannone

**Abstract** This paper deals with a red wire which connects the robotic developments in an Italian University, Politecnico di Milano, where the Dept. of Mechanics has conducted applied researches since 1977, at the dawn of Robotics, in the science of robots. Recently, on May 4, 2013, the European Project Locobot won the EU Open Doors selection in Brussels, chosen as one of the most significant projects in the European Union. The fourteen robots that were developed are now housed in the National Museum of Science and Technology “Leonardo da Vinci” in Milan, and their sequence represents an evolutionary story inside science and technology. The main principle is that the past results are a growing and fertile terrain for the future, as well as being a sign of unforeseen developments.

## 1 Introduction

The science of robotics was born in antiquity, in ancient Greece, even though it might now be considered a poor version, without computers, processors and data networks. But even then, Erone was designing a system to adjust the production of energy (10 A.C). In 1490, Leonardo da Vinci realized an automatic animal-like robot. The Japanese arakuri Ningyo (mechanical puppets) of the 17th century offered robotic, automatic, very elegant gestures. Vaucanson in France in 1739 designed near robotic animals, with very sophisticated mechanisms. In 1801, the Jacquard loom for manufacturing fabrics worked with a punch card, which programmed the motion. Asimov, Verne and many other writers invented automatic,

---

A. Rovetta (✉)

Department of Mechanics, Politecnico di Milano, Via Lamasa 1, 20156 Milan, Italy  
e-mail: alberto.rovetta@polimi.it

V. Iannone

Fondazione Museo Nazionale della Scienza e della Tecnologia “Leonardo da Vinci”,  
Via San Vittore 21, 20123 Milan, Italy  
e-mail: iannone@museoscienza.it

almost robotic, systems anticipating, by many years, current inventions which are now in common use in the world. What defines today's robotics? Robotics 2000 provides closed-loop systems with internal control, sensors, and actuators that command a system programmed by human intelligence. This work draws a red line through the robotics projects realized since 1977, many of which already offer performance similar to human functions, such as voice control and machine vision, locomotion controlled by the balance of the body, and the perception of neuromotor status. The history of robotics is a piece of human development, and its achievements also envelop intellectual, economic, industrial, social, and even ethical and spiritual developments. The work methodically traces the field's development from 1977 to 2014, and concludes with an examination of an innovative project in development of an intelligent mobile robot platform, which also has a primitive but strong factor of interaction with human beings. Because the relationship between the robotic machine and the human being, be it in the factory, at home or on another planet somewhere in space, is the crux of any development, the machines created by man must be dedicated to his/her welfare and the furtherance of his/her happiness. The red wire of robotics is also a symbol of the great path of mankind, in all its aspects.

## 2 Robotic Evolution

Robots are an evolving species, and day after day, they change to adapt to new software, to more efficient and less expensive sensors, and to the needs of a global society, alive and full of criticism for the past. The Department of Mechanics at the Politecnico di Milano has collected all the robots developed since 1977 by Prof. Rovetta and given them to the National Museum of Science and Technology "Leonardo da Vinci" in Milan. The day it all began was in June 1977, when the Director of the Institute, Prof. Emilio Massa, announced that he wanted to explore the reality of robotics, subsequently sending Prof. Rovetta to the first Congress of Robotics in Nottingham, England. Few researchers around the world took part, and yet all could feel in the air that a new world was taking shape and that robotics would change the lives of everyone. From then until now, the Department of Mechanics has drawn up a route with a red cable, scientific, cultural, and above all human, to show how the history of science can also be experienced and represented through a dynamic and brilliant museum, like the National Museum of Science and Technology "Leonardo da Vinci" in Milan, which reports on robotics. In 2013, the robot Locobot was selected in Brussels as a model project for Europe, and by May 4th, 2013, it had been visited by about 10,000 people. The robot Ladyfly entered into the Italian Space Agency's plans for exploration of the Moon and its revision began immediately with an official operative and lively proposal. It was subsequently necessary to donate the series of dynamic collection of fourteen robots, which cover the period from 1977 to the present. The last robot, Locobot, is still under development (Fig. 1).

### Platform Description

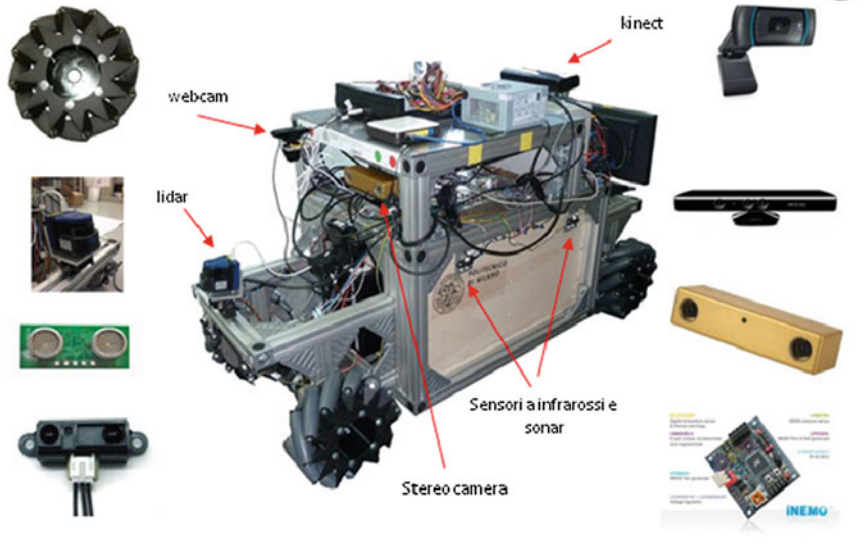


Fig. 1 Locobot robot, Low Cost Robot for co-workers, a European Project in new robotic manufacturing

## 3 The Red Cable

What is the red cable that guides us through the fourteen robots?

We will be examining the accompanying figures of all fourteen robots, all designed by Prof. Rovetta. The first track was the research on the human hand, the “divine” instrument given to man, confirming the birth of intelligence. The hand is the expression of the brain, and Michelangelo, in the Sistine Chapel, showed that God touches man, the finger of the hand being the means of communication. The second element, developed about 30 years ago, was the robot Gilberto, controlled by voice and vision with a microprocessor, and conceived as an arm with a shoulder and a head with a camera, representing the anthropomorphic thought and inspiration that went into the project. Gilberto was the world’s first, and was also mentioned by Asimov in one of his famous books. The third phase was applied to new application robots, in particular, those created for remote surgery. At the Department of Mechanics, telesurgery was born, and all over the world, surgeons now learn and copy the methods of four channels for remote operation by surgical robots. Meanwhile, biorobotics began to design mannequins, including Michelangelo, a human-shaped dummy used to study heart diagnostics. Robotics was elevated to brain control with Daphne and DeeDee, both of which used the principles of biorobotics to demonstrate human neuromotor behavior, an entry into



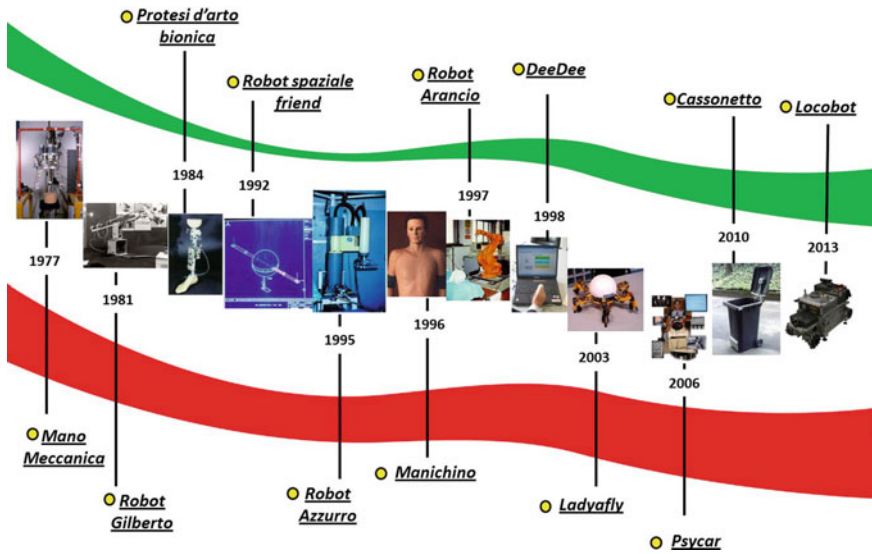


Fig. 2 The red wire in robotics from 1977 to the present at the Politecnico di Milano, Dept. of Mechanics

the world of neurology. Other fascinating robotic systems followed, including some that functioned within the pleasurable realm of games and play. Then, everything changed when Ladyfly exploded onto the scene, ending up on the front page of the New York Times on February 22nd, 2008, as a new approach in robot dynamic locomotion with six legs and six wheels (Fig. 2).

## 4 Robots in the Museum

A successful museum manages to meet its aspirations for the protection, preservation and dissemination of contents and cultural evidence, adapting its structure to all different systems with which it interacts. The structure of the museum dedicated primarily to science and technology shall adopt the best solutions that allow it to:

- Search for and select the scientific and technological processes/changes that are paradigmatic of the history of humanity;
- Protect, conserve and enhance the tangible and intangible evidence of those processes and of those scientific and technological models universally considered essential;
- Disseminate scientific and technological development to all types of users.

Particularly for the contemporary process of science and technology, it is necessary to choose what to preserve and how to enhance it, so that these evidences are

not lost as the result of technological obsolescence or the sheer amount of materials to be managed. A European consortium for the safeguarding of the scientific-technological heritage of the last sixty years was formed just for this purpose; it is coordinated by CNAM (Conservatoire des Arts et Métiers) in Paris, with the National Museum of Science and Technology “Leonardo da Vinci” in Milan (MUST) serving as its Italian member.

The MUST opened on February 15th, 1953, created thanks to a group of Lombard entrepreneurs led by Guido Ucelli di Nemi and supported by public institutions. Today, it is a private foundation whose institutional associates include Ministries, Public Administrations and Universities of Milan.

The aims of the Foundation are:

- Promote, disseminate and make accessible technical-scientific culture in all its forms, implications and interactions with other fields of knowledge and with society;
- Offer a communal space for dialogue, discussion and collaboration between the worlds of research, production, citizens, institutions, schools and other museums;
- Research, acquire, preserve, make accessible, interpret and communicate both tangible and intangible evidence on science, technology and industry with reference to the past and present, increasing the Museum collections, archives and library;
- Research and develop educational methodologies, tools and activities for the involvement and participation of different audiences (especially new generations) in meaningful experiences related to science and technology and to their place in society and in everyday life;
- Study, research, interpret and communicate worldwide the engineering work of Leonardo da Vinci, his historical and social context, his relation with nature and art, and the legacy of his research method in contemporary society.

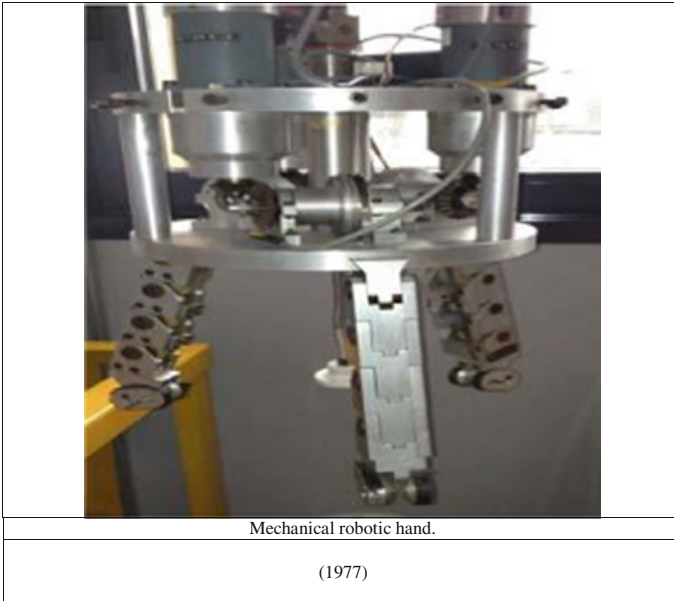
In the collections of the museum in Milan, up until two years ago, there wasn't any material evidence of Robotics, despite the long history of dissemination of topics related to Robotics in the museum's exhibitions and interactive workshops (i.labs).

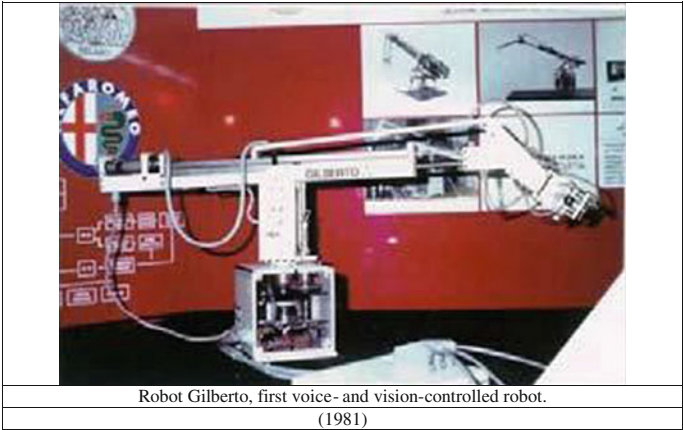
In 2013, the museum acquired fourteen robotic systems from the research activities of the Department of Mechanics of the Polytechnic of Milan (POLIMI), products of Prof. Rovetta. The choice of robots and related intangible assets was made by the museum and POLIMI jointly; to do that, they explored the origins of Robotics, researched its distinctive characters, traced its evolutionary processes, outlined its boundaries inside science and technology and its cross-cutting issues, and then selected those tangible and intangible assets deemed most essential for safeguarding and transmitting the field into posterity. Much of the material chosen was taken from the work of Prof. Alberto Rovetta, who has been engaged in the field of Robotics since its origins in the 1970s.

This POLIMI donation, in particular, allows us to trace the historical paths of the birth and evolution, since 1977 in Italy, of the robotic systems. The international

peculiarity of POLIMI projects, including their interconnections with the Italian and foreign markets, allow for widening the horizon of acquired items to the international robotics of the last forty years.

The collection donated to the Museum has proven useful in many different ways: for example, here, we can follow the chronological and conceptual orders simultaneously. We can start with a prototype from 1977 that comes from pure research and that explored the new concepts surrounding the possibility of giving a robot hands, legs, arms, fingers and a brain: a prototype of a robotic hand, which remained unchanged despite forty years of experimentation, because of basic principles of prehension. Design of the first bionic limb prosthesis followed in 1984.





In the early '80s, the Gilberto robot was designed: it was a machine that read, spoke, listened, and moved, and which, indeed, was capable of choosing the best path along which to move. This evolution in Robotics demanded consideration of human nature and the dynamics of movement.

Between the late '80s and early '90s, Robotics responded to the need within the medical community for technology that would allow surgery to be performed with the precision of a robot and the skill of a surgeon, and which could also overcome the problem of great distance between the patient and the surgeon. The robotic systems in the collection show that distance is no longer a negative constraint, but a condition that can be overcome with tele-robotics. The collection features two robots from the '90s that fulfill this request: the Sankyo robot, and "RoboScala".

Robotics has spread all over the world, and even into space. In 1994, a body was designed with two mechanical arms, under the benign name of "Friend": it can help astronauts in the recovery of lost objects in space, and also, in case of emergency, help the astronauts themselves. Robotics presents a new way of looking at life on Earth and in space, as an adventure every day.

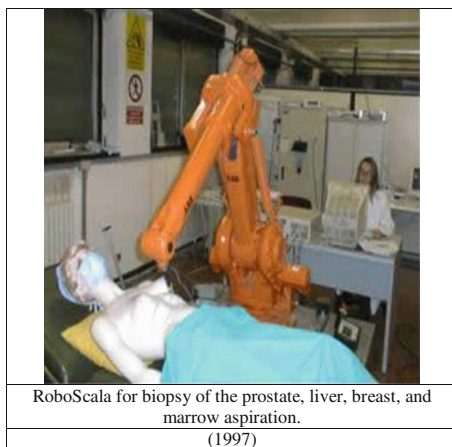
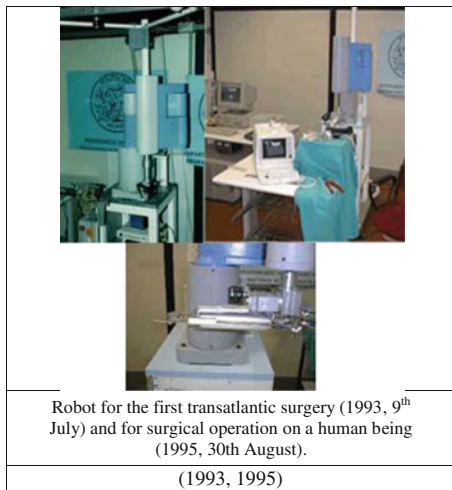


Bionic limb prostheses, with microprocessor control, the first in the world  
(1984)

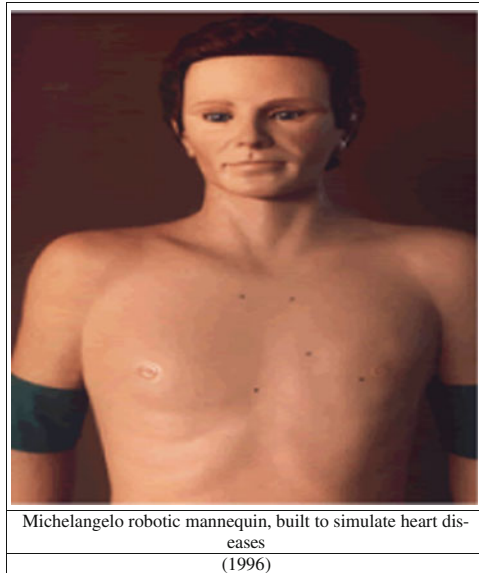


Space Robot Friend for the Italian Space Agency on the International Space Station  
(1994)

Medicine, particularly cardiology, also wishes to benefit from the abilities of the robot, and in 1996, a mannequin, named “Michelangelo”, built in the likeness of a human body, with hands, fingers, eyes, and even nipples, was made to simulate and study human heart disease.



By the '90s, Robotics had exceeded physical simulation of the human body, and the Robotics Laboratory of the Department of Mechanical Engineering at POLIMI began a second revolution.



Prof. Rovetta recalls: « It all started with a sentence by Professor John Carew Eccles, Nobel Prize for Medicine, which stated: “Enough with the mechanical robots. You must now start from neural man who perceives feels, acts, and explore how Bio-robotics can help”». Ten years later, two bio-robotic systems, called Daphne and DeeDee, had been produced. They were used by the Ferrari Racing Team and the Traffic Police in Italy; participated in studies on Parkinson’s disease and Huntington’s chorea; and were adopted in sport, biathlon and on the shooting range for teams involved in the Olympic Games. The principle is that the movement of a finger can be traced back to the mental state of the neuromotor control of a person, a fact that can be useful for analysis, care, support and treatment. The initial thread has now become a big red wire, which spreads in many directions; from this point on, Robotics research was oriented to human existence, such as the science of real life, of everyday life.

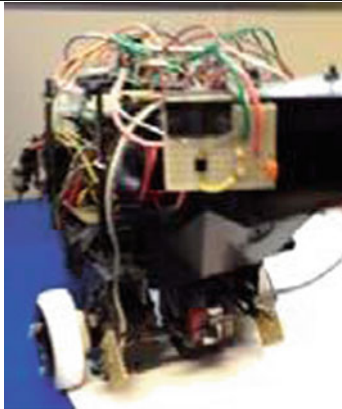


After 2000, Ladyfly was born, a product of learning that, in the current proposals, will, perhaps, also be used on the Moon to map its surface.





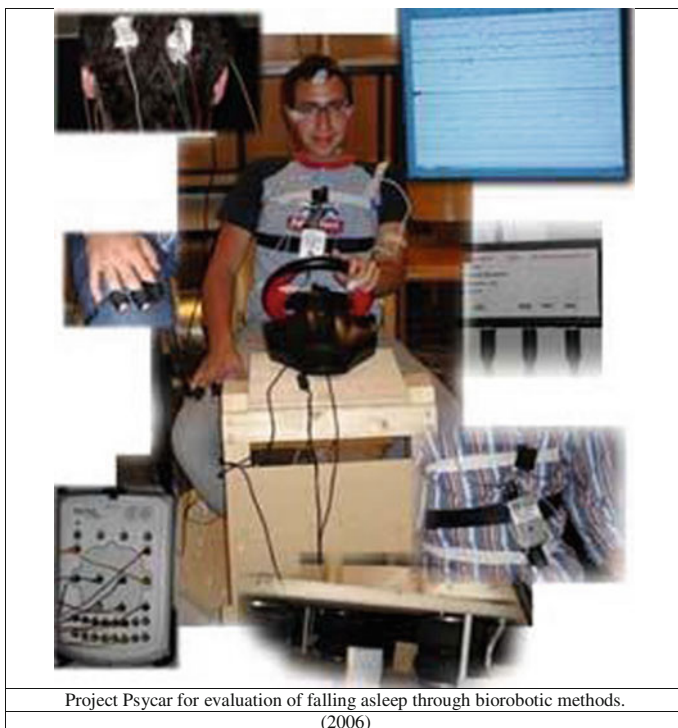
Ladyfly Robot for Planetary exploration, developed for the Italian Space Agency  
(2003)



Robot Grisou, to chase the flame and turn it off  
(2004)

Some projects, such as Cleanwings, were born for the purpose of waste collection; intelligent containers, adopting the principles of robotics and satellite transmission, were presented at EXPO 2010 in Shanghai.

According to the new manufacturing principles, the platform Locobot was born in 2013. It is a robotic platform, intelligent, perceptive, offering and receiving emotions and sensations. This robotic system has recently been proposed for acquisition for the museum's robot collection.





Robotics is a great example of a scientific and technological development that can be enhanced in a museum: the whole museum structure becomes the seat of creativity, reflection, awareness and knowledge for exploring in detail how human action can spur innovation and application of a particular field to real needs.

The museum continues to work to create its heritage, and this robot collection, accessible through exhibitions and educational activities, and through its website, is a large part of that endeavor.

In recent years, for example, MUST, in parallel with the activities of the Robotic i.labs, organized various events, such as the annual meeting of the “European researchers’ night”, which involved tens of thousands of visitors. During these events, the robots were shown and explained by the entertainers, POLIMI’s researchers and the museum’s staff, through exhibitions and interactive workshops; some robots were activated and, as in the case of Ladyfly and Locobot, the public interacted with them. A wide variety of technological communication tools were included to stimulate the minds of the public: digital documentation, technical

drawings, letters, notes and historical videos; 2D and 3D animations; interactive games available on touchscreens; the opportunity to connect in real time with international research and manufacturing activity; and dissemination on the web.

The museum continues its work with the help of the worlds of research, production, the citizenry, institutions, schools, and other museums.

## 5 Intelligent Robotics in History with an Eye Towards the Future

In 1981 (see Levi-Montalcini 2004)<sup>1</sup>, Gilberto was designed and developed to be able to speak and recognize voices, and also to recognize objects thanks to a vision system, Rovetta (1987). It was controlled by a microprocessor, as reported by Isaac Asimov in his book on Robotics. As presented in (see foot note 1), films taken at the time show the flexibility and reliability of Gilberto in 1983. The Polimi Platform was behind this particular development (see Levi-Montalcini 2004) (see foot note 1). In 2010–2013, the LOCOBOT European Union Project<sup>2</sup> at the Politecnico di Milano, Laboratory of Robotics, proposed an intelligent Platform, performed for the applicative results. The name Locobot means Low Cost Robot, and the platform performed at the Politecnico di Milan had practical demonstrations, as in the contract signed in 2013 with the AUDI Co., who became a partner in the project. The Polimi Platform for Locobot includes speech recognition, voice control, vision recognition, lidar and vision control, autonomous motion with exploration and navigation, and a high level sensor fusion. It has been applied to tests at the Audi Co. for the improvement of manufacturing activities in cooperation between workers and robotic systems.

The Polimi Platform (that is to say, the previous design and practical working application of the Polimi—Platform) performs a controlled motion in synchronization with the production line, according to the Locobot Project plan, as reported in (see foot note 2). Movies, photographs, tests and analytical developments of the studies are accessible from the EU Commission. The Polimi Platform for Locobot was officially presented at the Celebration Day of the European Union in Brussels, at the event called EU Open Doors, as an honored example of one of the best (15 out of 3700) scientific research results of all European Union Projects. Locobot is a new step in the future of robotics. Its dissemination is currently in motion and the research into the Locobot Platform will lead to even more genuine advancements in robotics, allowing us to move beyond the old and surpassed ways and methods, which must be gradually retired. Since August 1st, 2013, the Polimi Platform has taken the subsequent development of Locobot to new places. The plan is to increase a new type of intelligence within the system, particularly in the platform, which is

---

<sup>1</sup><http://robotica.mecc.polimi.it>.

<sup>2</sup><http://www.locobot.eu>.

equipped with a new nano microphone system for high level performance and new logical and emotional software to enable the participation and cooperation of the worker(s) with the robotic system. Robotics up until the year 2000 mainly developed industrial robots, and the research followed. Now, it is a time of new research, research that must have immediate applications, as the Polimi Platform for Locobot does with Audi, towards a genuine reality of cooperation between man and robots in actual environments. The Laboratory of Robotics of the Politecnico di Milano dedicated the years from 1992 to 2013 to the development of substantial research into applications (see foot note 1) for the neurological aspects of human behaviour, with studies on neuromotor control in cooperation with Nobel Prize winners (see Sherrington 1906; Sperry 1970). Now, we present our results in new robotics, a term that should come to be associated with low cost, high performance, and great reliability, as the Politecnico di Milano and its development, the Polimi—Platform, offer in great measure.

From 1981 to today, we have made great strides in developing useful (and patented) robotics (see foot note 1), and the Polimi Platform is one of the best trends which the Politecnico di Milano's Dept. of Mechanics is developing.

## 6 Special Intelligence

The Robotic Mobile Platform is a new version that has been developed, characterized by its special intelligence. The structure of the platform is defined by many independent sensors connected to a central PC via software, which uses independent and interconnected nodes. All information from any of the sensors reaches the central computer directly and, based on the data processing, controls the movement. The entire system is monitored on the screen of the Platform and can also be seen on a remote computer, a tablet, a cellphone, or on the Internet. The Robotic Mobile Platform goes a step further, and adapts to the new frontiers of bio robotics and modern neurology.

The Robotic Mobile Platform acts on the basis of human intellectual perception and logic, feelings and emotions (see Eccles (1964, 1996); Edelman (1987)). It uses a special node with logic, born from the structuralism which has pervaded all the human senses, the natural and theoretical sciences, philosophical and engineering disciplines, and neurological and physical knowledge in recent years.

The logic of materialism considers the only reality to be that which is external nature to man, who experiences this reality as a passive protagonist. The logic of idealism (especially that of Plato and Aristotle (330 BC) as carried on in the works of Thomas Aquinas, Kant, and Hegel) considers instead that only ideas truly exist and that reality must adapt to these ideas that enclose the whole. Today, neither philosophy is fully accepted.

Nowadays, popular thought tends towards structuralism, in which the perception and intellectual understanding of things and reality differ from individual to

individual. Everyone structures their own life according to the experience of every moment.

Structuralism knows that reality is perceived and felt differently by each person, depending on his/her sensory system, nervous system, memory capacity and interpretation, and conscious and unconscious experience. Materialism and idealism do not consider the unconscious and the instinctive, both of which have great importance in human life. The Platform wants to be the first robot (or robotic system) that works with structuralism. It uses the same hardware used by the Robotic Mobile Platform, uses the same nodes, as if they were the dendrites of the human brain, and uses them in a new way, by interpreting the patterns of structuralism.

The Robotic Mobile Platform behaves differently depending on the reality surrounding the human beings with whom it interacts.

The human person interprets reality not through digital values, but through models created by each person with the senses, and these models are filtered and modified at each step by the sense organ. They transduce signals to be analyzed by the brain, providing synthetic information, short and compact, so that the information is present in few elements. The Robotic Mobile Platform uses self-learning to grow and increase its basic statistical information, becoming increasingly safe and reliable. The limited perception of the Robotic Mobile Platform can be changed according to the environment, to the people around it, and to the developed and expected events. The Polimi Platform will have its own special intelligence, one that is adaptive, not as a machine but as an object built by man for man, with a special intelligence gained from reality and life through restructuring.

Structuralism involves processing signals, derived from each sensor in order to provide the values of the models and the signals as indices of perception and communication. They are sent to all nodes of the computer to be processed by the network of nodes, passing through the nodes of the “special intelligence” that uses new logical models of interpretation.

The “new logic models” are nothing more than the recovery of certain aspects of formal logic, ancient and ever born alive. They connect logical action, affection, and emotion, without any distinction between quality and quantity, and an application of brain control that goes back to the basic principles of Aristotle, who first spoke of it.

The first consideration is that formal logic, from the time of ancient Egyptian and Chinese cultures, has dominated the fields of robotics and systems engineering, up until a few years ago. Today, technical determinism has been transformed into an operational activity, which is very interrelated, and no longer sequential. Only formal logic and traditional engineering maintain a rigid structuralism. Modern science is all about communication between disciplines, emotional participation towards the progress of mankind, and is a political and strategic choice for the driving of society towards the development of the best quality of life. Sherrington (1906) by Sir John Eccles, Nobel Prize winner, represents the first step in the new developments in Robotics from the Dept. of Mechanics, Politecnico di Milan. After his visit and counsel in 1992, the Robotic Lab began delving into the real

neurological aspects of intelligence, searching for the behavior of the human body. A hand grasping is a very complicated process, and robotics can really only reproduce a part of the human grasping process, with alpha and gamma circuits of the brain in parallel action. The same neurological aspects have been considered and have been developed, with very active and practical results, in the Daphne project (see foot note 1). Sperry (1970) by Montalcini, Nobel Prize winner, became very well considered after her visit and cooperation in new ideas and design towards new frontiers for the new robotics. Her skill in the field of neurology gave her the courage to transcend the traditional logic of robotics, in which the mechanisms obey the software, according to deterministic laws that really do not exist in life.

## 7 Description of the Robotic Mobile Platform

Figure 1 shows the Robotic Mobile Platform, with its webcam, lidar, infrared sensors, ultrasonic sensors, Kinect, stereo camera, and omnidirectional mecanum wheels. Safety is guaranteed.

The mental spaces that led to the design of the Robotic Mobile Platform were born out of the search for a robotic system that interprets the face, words, movements, and also the intentions and actions of human beings, adding a genuinely active factor of cooperation to the robotic machine. The concepts are spatial, in the sense that concepts are not running by the traditional engineering method, the consequentiality after execution of the project, but working for cyclic rings linked together, as in a necklace. The strength of the series lies in its ability to add rings, and bring new systems, attached to the preferred or more suitable ring. The Robotic Mobile Platform does not want to look like a humanoid robot, with face, legs, arms (see website (see foot note 1), multipurpose hand, 1979; Gilberto, 1981; prosthesis, 1984, etc.). Its genetic shape is to have a horizontal drooped body that is linked to a movement parallel to the ground. The movement in the version examined here occurs with four wheels, and a version with six legs has also been studied and developed up to a stage of intelligence. The Robotic Mobile Platform has four omnidirectional wheels, such that the robot platform can move in any direction on the floor, with a control that allows for pure rotation or pure translation, and, of course, the rotation and translation motion.

### 7.1 *Exploration and Automatic Navigation, with Perfect Understanding of the Environment and People*

Figure 1 shows the Robotic Mobile Platform during its navigation, after exploration, with the action of all sensors and actuators.

The Robotic Mobile Platform explores its full environment through a 3D (and 2D) radar, while a webcam explores the ceiling and stores the main data and a stereo camera explores, stores and analyzes all side walls and fleshes out the main features. All results are transmitted into the memory of the PC board and are stored. A special widely used tool, called Kinect, is adopted to recognize the movement of human arms and legs, and also to recognize faces and expressions. These data are part of the exploration of the environment in which the Robotic Mobile Platform has been chosen to operate. If the environment changes, the Robotic Mobile Platform runs a new scan and stores all the obtainable data.

Simple algorithms, traditional as well as new, are applied, beyond the formal logic that is expressed with usual logical determinism, even with statistical forecasts. Each piece of received, read and interpreted data must pass through the filter of a logical non-formal structure and must obtain an index of validity and truth, which is now used in the application. In this way, it is like building a “mental space” for the robot with a “special intelligence” that must be filled, and must be made active and positive. The new “intelligent special robotics” can free the worker, the designer, the user, every person who interacts with the robot, from the bondage of the obligation of an asset.

## 8 Applications

The application of the Robotic Mobile Platform is devoted to the systems and environments in which there is an interaction of machines/robots with a human presence (Ceccarelli 2001). Locobot can synchronize its motion with the automotive production line where different cars are produced. The cooperative motion of the Polimi Platform for Locobot with the suspended production line, where cars are moved, is a very satisfying thing to see. Locobot supports the assembly line, increasing the efficiency and velocity of the entire line. The website for the Locobot Project (see foot note 2) shows all the actions and demonstrations, which are spectacular in the context of traditional robotics. The meaning of “robot” must change. Up to now, in the industrial field, “robot” has been a system to be programmed, performing programmed tasks, with no autonomous existence. Some research robots appear to be independent, but this is an illusion, because all robotic behavior depends on a line in a software program. When we say “emotional and intelligent robot”, we are clearly referring to the utilization of a new kind of internally controlled logic, and this “internal logic” will also consider the psychological effects that human behaviour induces in the robot itself. Human psychology is always a factor in all of our actions, and robots, those most sophisticated of production machines, can participate in this reality in an optimized and performance-based way.



Possible Robotic Mobile Platform applications for normal use include:

1. Manufacturing industry for moving parts
2. Neurodegenerative care
3. Cleaning of supermarkets
4. Cleaning of offices
5. Use in restaurants
6. Use in public transportation hubs
7. Robotics platforms for space exploration
8. Building construction
9. Replacement of items in supermarkets
10. Logistics in industry
11. Mobility in hospitals
12. Transportation in airports
13. Assembly in the manufacturing industry
14. Self-guided buggies

## 9 Conclusions

No aspect of humanity—be it scientific, cultural, technical, economic, etc.—exists without the imprint of the past. Our vision of the future can only be rich and secure, as we have learned time and again, if it is filtered through the genuine realities of the present and the past. Robotics plays this role, because, in just a few years, it has changed the world of work. It has had an effect on the physical fatigue of the worker, has increased surgical skill in the operating room, has explored immense and distant planets, has visited the seabed, and now addresses the daily activities, domestic and otherwise, of humanity. What, today, is changing the trajectory of robotics? As our impetuous times introduce the technology of human communication, robots may very well explode in beauty through processors ever smaller, with ever more accurate perception of the environment, and indefinite storage of data, even in the cloud. The person is always more constrained inside the robotic machine, which often builds and adapts to his measure. The robot is becoming personal in everyday life, both at work and in recreational activity. Wealth is due to increased perception of the robot, the increase in its decisions, always controlled, and in its sharing in activities with human beings. The story of robotics described here maintains a scientific basis and is historically sound, projected toward an intelligent platform, born to work with man. Now, the platform is reconfigured to be used in space, in the workplace, in the home, in the museum, in any environment where the machine can be a life-long friend of the human being.

## References

- Aristotle, (330 BC), *Categories*, 8; 9
- Ceccarelli M (2001) A historical perspective of robotics toward the future. *Fuji Int J Robot Mechatron* 13(3):299–313
- Eccles JC (1964) *The physiology of synapses*. Springer, Gottingen
- Eccles JC (1966) *Brain and conscious experience*. Springer, Heidelberg
- Edelman GM (1987) *Neural Darwinism*, New York
- Levi-Montalcini R (2004) *Abbi il coraggio di conoscere*, Milan
- Rovetta A. (1987), *Voice Control*, Encyclopedia of Robotics, Vol. III, Ed. Dorf
- Sherrington CS (1906) *The integrative action of the nervous system*. Yale University Press, New Haven
- Sperry RW (1970) Cerebral dominance in perception, in early experience in visual information processing. *National Academy Sciences*, Washington