

Ontological Modeling Applied to Engineering and Governance Processes of Customer Complaints

Orlando Agostinho¹, Carlos Mendes², Miguel Mira da Silva¹, and José Tribolet¹

¹Department of Information Systems and Computer Science,
Instituto Superior Técnico, University of Lisbon, Portugal

²INOV, Avenida Duque Ávila 23, 1000 Lisboa, Portugal
jose.tribolet@inesc.pt, carlos.mendes@inov.pt
{mms, orlando.agostinho}@ist.utl.pt

Abstract. By selecting and adopting best practices organizations expect to benefit from the experience of other organizations and avoid common mistakes that these organizations have committed in the past. However, the adoption of best practices is not a trivial step due to several reasons. One reason is the fact that, to implement best practices, organizations need to migrate from an *as-is* state (before the adoption) to a *to-be* state (after the adoption), and the current best practices do not provide methods based on strong conceptual foundations to support this transition. Our proposal is a method supported by the Enterprise Ontology to align the current organizations' processes with the industries best practices. We applied the proposed method in a Portuguese Telco and aligned a process of customer complaints with The Information Technology Infrastructure Library (ITIL) best practices. As result the organization found several improvements to the mentioned process based on the ITIL best practices.

Keywords: Enterprise Government, Enterprise Ontology, DEMO, Best Practices, ITIL, Incident Management.

1 Introduction

Adopting best practices involves changing the state of an organization from an *as-is* state to a state that is aligned with the best practices processes. This implicates that the accountable organization for this transition must have awareness of what the *as-is* state is and what the *to-be* state looks like. This awareness requires the existence of a connection between the organizations' and the best practices processes, so the changes can be made. The problem is that current best practices do not provide methods based on strong conceptual foundations to support this connection. In other words, the best practices only focus on what should be implement and not on how organizations should change their processes in order to achieve what is proposed.

For example, despite The Capability Maturity Model Integration for Services (CMMI-SVC) recommends that when using its model, we should use professional

judgment and common sense to interpret it for each organization [1], this solution does not specify how it should be implemented.

Another obstacle to a smooth transition is the fact that processes often rely on "knowledge workers" who know how to overcome the situations and who ultimately ensure the "normal" operation of the company [1]. The problem is that the knowledge they have, usually is only in their minds, and they cannot model that knowledge since most of them are not familiar with modelling techniques.

Therefore, the specific problem addressed in this paper can be described in the following research question:

How to take advantage of the Enterprise Ontology and DEMO to align the organizations' business processes with the industry's best practices?

DEMO (Design & Engineering Methodology for Organizations) is a methodology for modelling, (re)designing and (re)engineering organizations and networks of organizations. The theory that underlies this methodology is called Enterprise Ontology (EO) that by itself is based on the speech act theory [2]. We decided to use EO and DEMO methodology, since EO and DEMO illustrate the way to profoundly understand, (re)design, and (re)engineer organizations. Additionally, DEMO has proved to be efficient in extracting the knowledge from the "knowledge workers", due to the potential of the universal transaction patterns.

In order to solve the mentioned problem, we propose a method that allows organizations to have processes aligned with the best practices. This method is composed by the following steps: produce business models and their respective best practices models in such a way they are coherent, comprehensive, consistent, and concise; compare the process models versus the best practices models; reengineer the process being studied according to the analyses from the previous steps.

We applied the proposed method in a Telco organization in which we focused in the incidents of the mobile portability process.

This remaining of this paper is structured as follows. In Section 2, we present a brief overview of the literature on the research problem area. Afterwards, we present our proposal, namely the proposed method (Section 3). In Section 4, we explain the demonstration of the proposal. In Section 5, we show the evaluation process, and finally, we conclude the paper by reinforcing the main conclusions of this research (Section 6).

Our study was conducted using the Design Science Research Methodology (DSRM) that aims at creating and evaluating IT artefacts intended to solve identified organizational problems [3]. This section corresponds to the problem identification and motivation phase of DSRM. It also corresponds to the objectives definition phase.

2 Related Work

In this section we present the related work that is divided in three subsections. First, we describe the solution from the best practices that we used in this research (ITIL, namely the incident management process). Afterwards, we describe the Enterprise

Ontology and respective modelling methodology DEMO. Finally, we conclude this section with an analysis of the current solutions that used DEMO to improve processes.

2.1 ITIL – Incident Management

In ITIL terminology, followed in the official book of ITIL [4], an incident is defined as an unplanned interruption or reduction in the quality of an IT service.

Incident management is the process responsible for managing the lifecycle of all incidents. Incidents may be recognized by technical staff, detected and reported by event monitoring tools, communications from users (usually via telephone call to the service desk), or reported by third-party suppliers and partners.

The process activities to be followed during the management of an incident are: Incident Identification, Incident Logging, Incident Categorization, Incident Prioritization, Initial Diagnosis, Incident Escalation (Functional and Hierarchic Escalation), Investigation and Diagnosis, Resolution and Recovery, and Incident Closure.

2.2 Enterprise Ontology – DEMO

Enterprise Ontology [2] is based on four axioms – operation, transaction, composition and distinction – and the organization theorem. The operation axiom states that the operation of an enterprise is constituted by the activities of actor roles that are elementary chunks of authority and responsibility, fulfilled by subjects. In doing so, these subjects perform two kinds of acts: production acts (p-acts) and coordination acts (c-acts). These acts have definite results: production facts and coordination facts, respectively. P-acts contribute to bringing about the goods and/or services that are delivered to the environment of the enterprise. C-acts represent commitments regarding the performance of production acts.

The transaction axiom states that coordination acts are performed as steps in universal patterns. These patterns (or transactions), always involve two actor roles (initiator and executer) and are aimed at achieving a particular result. A transaction develops in three phases: the order phase (O-phase), the execution phase (E-phase), and the result phase (R-phase). In the O-phase the two actors agree on the expected result of the transaction; in the E-phase the executer executes the production act needed to create the expected result; and in the R-phase the two actors discuss if the transaction result is equal to the expected result.

The composition axiom establishes the relationships between transactions. This axiom states that every transaction is either a) enclosed in another transaction, b) is a customer transaction of another transaction, or c) is a self-activation transaction.

The distinction axiom states there are three distinct human abilities playing a role in the operation of actors, called *performa*, *informa*, and *forma*. An ontological act (*performa*) is an act in which new original things are brought about. An infological act is an act in which one is not concerned about the form but, instead, about the content of the information. Datalogical acts are related to copying, storing, and transmitting data.

2.3 DEMO Based Solutions to Improves Processes

We analyzed three solutions that contribute to the state of art of DEMO based solutions that allow to improve processes.

In 2010 the potential of bringing together the notions of Enterprise Governance (EG) and Enterprise Ontology was evaluated in [5]. This research developed a set of conceptual models and an underlying reference method to support the EG in designing a set of normative outputs. This method uses the notions of competence, responsibility and authority designed at the ontological level within DEMO to address: how to restrict the undesirable freedom of the process of detailing the ontological models by addressing how actor' acts should be supported at the infological, datalogical and technological levels [5].

In 2012 another research presented a method to analyze the consistency of a process model according to business transactions [6]. The method makes possible assessing the consistency of a business process in terms of the business transactions that can be inferred from it. To do so, it takes as input a process model that is converted to a transactional model. The transactional model is then analyzed and revised so that all transactions become consistent according to the patterns of DEMO. Finally, the original process model is revised to comply with the transactional model. As a result, the revised business process becomes consistent with the corresponding transactional model [6].

Additionally in 2012, a method for improving healthcare management using Enterprise Ontology [2] and Lean Thinking [7] was proposed in [8]. The proposed method, illustrated in Fig 1, identifies innovations to improve the healthcare management.

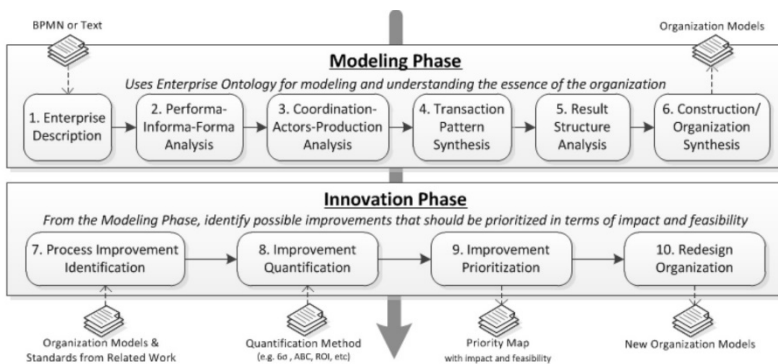

Fig. 1. Graphical Representation of the method

The method starts with the *Modeling Phase*, which uses EO to study the organization and its processes. As result, this phase provides a structured working approach by layering the organization into three parts, and focusing only on the one that directly refers to the complete knowledge of the organization and independent of the implementation. Then it continues with the *Innovation Phase*. In this phase identifies possible improvements from the previous models, prioritizes them in terms of impact and

feasibility, and then proposes redesigned models for the organization. As result, this phase gives the appropriate tackle to handle the transformation process, and helps to choose the most profitable improvements first.

This method identifies possible improvements in which it is necessary to use some kind of partial judgment to identify transactions that do not seem essential and may be removed, changed, or automated. Whereas, our proposed method uses EO and DEMO for both the business process and the best practices in order to master their diversity and their complexity by the use of the same ontological models of DEMO. In that way, we can have the essence not only for the business process but also for the best practices and make a proper and impartial judgment about their similarities and differences.

3 Proposal

This section corresponds to the design and development step of DSRM. **We propose a method that relies on DEMO to align the organizations' processes with the industry's best practices.** The proposed method is intended to be used as a tool to make comparable what is now incomparable.

The method encompasses the following four steps:

1. Model the current state of a process to be optimized in DEMO;
2. Model the chosen best practices in DEMO;
3. Compare the DEMO models from the current process and best practices;
4. Reengineer the process according to the previous steps.

The **first step** is to model the current state of the process to be optimized in DEMO, using for that purpose the methodology proposed in [2]. In this step the "knowledge workers" involved in the process should be interviewed. The interviewers should prepare the interviews by collecting documentation about the process. As result, a white-box model of the organization being studied is obtained. A white-box model is a direct conceptualization of the ontological system definition and captures the construction and the operation of a system, while abstracting from implementation details. This white-box model is composed by four models: Construction Model (CM), Process Model (PM), Action Model (AM), and State Model (SM) [2]. If necessary, some information regarding the infological and datalogical layers (see Section 2.2) should be included. This information can be useful when the chosen best practices are rich in implementation details.

The **second step** focuses on modelling the chosen best practices in DEMO. Once more, the methodology proposed in [2] should be followed. As result, a white-box model of the chosen best practices is obtained. Since in this step there is no specific organization being modelled it may be useful to first model the best practices in The Business Process Modeling Notation (BPMN) and use the BPMN models as input to the methodology that produces the DEMO models. BPMN has been chosen because it is a standard of the industry with a well-known nomenclature. Both BPMN and DEMO models should be validated with experts of the related best practices.

The **third step** compares the two white-box models identified in the previous steps. This analysis compares the two ontological models (current process and best practices) by identifying their differences concerning mainly activities flow, actor roles, and complete transactions. Three components from DEMO can be used in this comparison: Result Structure Chart (RSC), Actor Transaction Diagram (ATD), and Process Structure Diagram (PSD). RSC can be useful to easily compare the two ontological models regarding the number of transactions, since the RSC only contains the transactions results and respective connections. In that way, we expect the two RSCs to be similar, and if it is not the case, we propose to identify the missing transactions from the best practices and add them to the ontological model of the organization. The ATD can be used to identify missing actor roles from the current process, since this diagram details two elements: actor roles and transactions. Additionally, ATD shows the boundary of the organization, as well as the interface transactions with actor roles in the environment. Finally, the PSD can be useful to identify different process flows between the process in study and the best practices. This analysis is possible since the PSD contains, for every transaction type in the ATD, the specific transaction pattern of the transaction type. The PSD also contains the causal and conditional relationships between transactions [2].

The **fourth step** bases the reengineer suggestions on the previous three steps and on the basics of Enterprise Governance [5]. From the first two steps one can identify missing atomic acts (such as missing promises) and inconsistent ones, just by developing the PSD, since this diagram imposes the specification of the complete transaction pattern for each transaction. The work from [6] can be used in this step. These improvements can be proposed also to the best practices and not only to the process in study, but this is out of this research context. Finally, from the comparison made in the third step of the proposed method, one can suggest improvements regarding activities flow, actor roles, and complete transactions.

4 Demonstration

This section corresponds to the design and development steps of the Design Science Research Methodology (DSRM). The demonstration was performed in a private company, leader in the telecommunications industry in Portugal, which we will call from now on ACME. In 2006, ACME had 1150 employees, 1518,5 millions € in revenues, and 215,6 millions € in profit.

We applied the proposed method to the ACME's customer complaints process and to the ITIL incident management. ACME did not have ITIL implemented. In order to model the customer complaints process in DEMO, **first step** of the method, we interviewed three "knowledge workers" from ACME. In order to exemplify the flow of this process, we describe a situation in which Alice (an ACME's customer) could not use her simcard on her phone. After some time, she decided to call her Telco operator, ACME, to ask for help with this matter. Throughout some interactions with the call center, she continued to not be able to use her simcard. Later, with a lot of trial and error, ACME finally found that Alice's number has been exported to another Telco

company without request from Alice. Once the company identified this, they requested the other Telco operator to return the number. Once Alice’s number was returned, she was finally able to use her simcard again.

The Actor Transaction Diagram of this customer complains process is illustrated in Fig. 2.

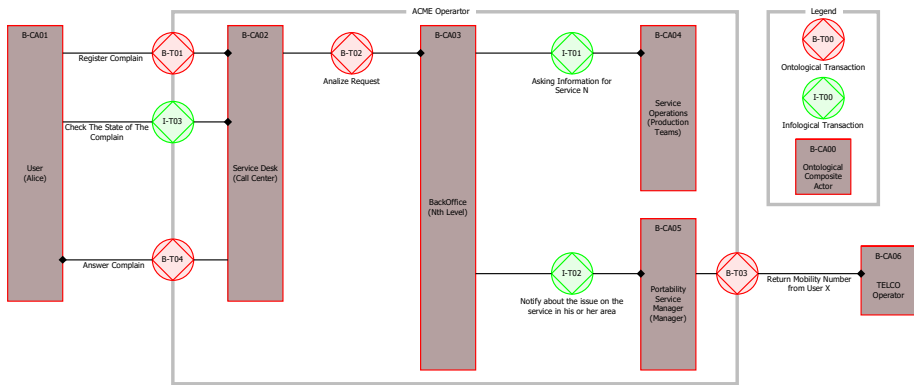

Fig. 2. Method – Step1 ATD of ACME’s customer complains process

We identified the existence of 4 ontological transactions, 3 infological transactions, and 6 actor roles. The ontological transactions are B-T01 Register Complain, B-T02 Analyze Request, B-T03 Return mobility number, and B-T04 Answer Complain. The infological transactions are I-T01 Asking information for Service, I-T02 Notify About the issue on the Service, and I-T03 Check the State of the Complain.

In the application of the **second step** of the proposal (modelling of the best practices in DEMO), we used the Incident Management of ITIL. We based this modelling on the official literature of ITIL [4] and on two interviews with ITIL experts. The resulting diagram is depicted in Fig. 3. For the sake of readability only part of the diagram is presented.

We identified the existence of 29 ontological transactions, 23 infological transactions, 27 elementary actor role, and 13 composite actor roles.

With the ontological models of the ACME’s process and the best practices, we identified the key transactions that were missing on ACME’s customer complains process (**third step** of the proposal). In order to do that, we used the Result Structure Chart (RSC) of DEMO for both ontological models from ACME and ITIL best practices.

Comparing these two figures, we identified the following transactions of ITIL best practices that were missing on the ontological model of ACME and that were suitable of being implemented in ACME: T02 - Recognize Suspicious Incident, T05 - Incident Identification, T13 - Incident Resolution, T06 - Incident Categorization, T07 - Incident Prioritization, and T20 - Incident Closure.

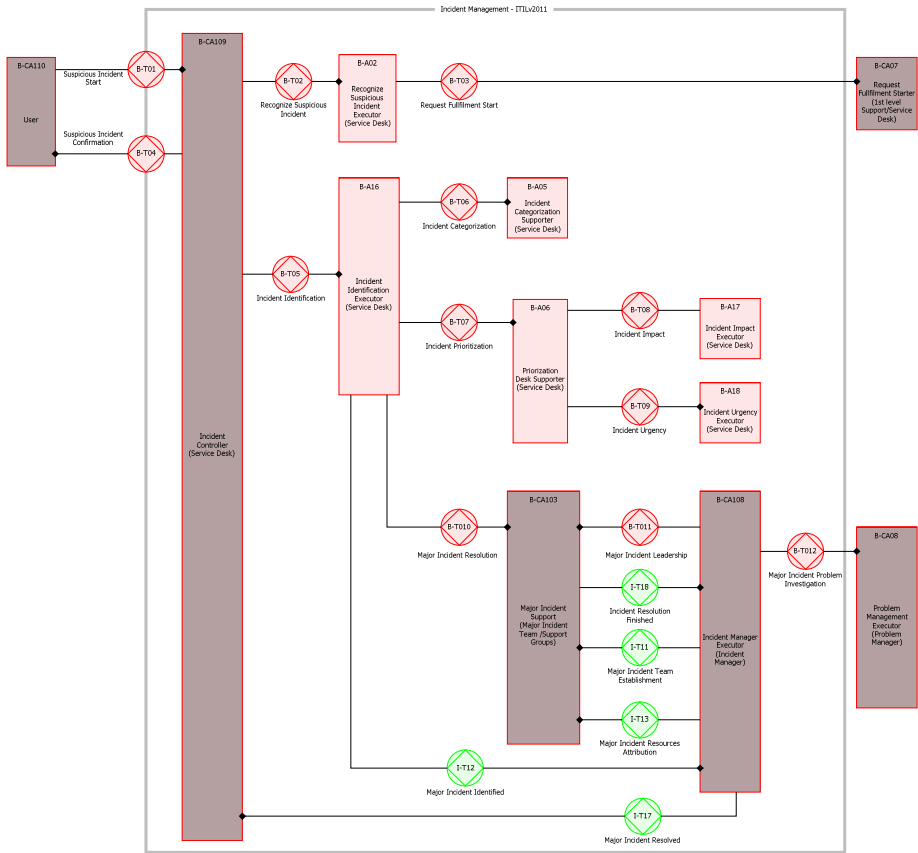

Fig. 3. Partial ATD of ITIL Incident Management

Finally, in the **fourth step** of the proposal, we proposed some reengineer improvements to the customer complaints process, based on the analyses from the previous three steps. Therefore, from steps 1 and 2 we found some improvements related with missing activities (mainly promises) and from step 3 we proposed the inclusion of the complete transactions already mentioned.

5 Evaluation

This section corresponds to the evaluation phase of DSRM and in order to explain the evaluation we use the framework proposed in [9]. This framework identifies what is actually evaluated, how it is evaluated and when the evaluation takes place:

- What is actually evaluated?** The artifact evaluated is the proposed set of steps of Section 4 (a design process) and the results of applying these steps to the ACME (process improvements; a design product);

- **How is it evaluated?** We used ACME employees' (knowledge workers) and ITIL specialists' feedback to evaluate the proposed artifact and respective results. They were interviewed in semi-structured interviews that took 2 hours each and were structured as follows: first, the researchers explained the proposed method and the ACME demonstration including the identified improvements. Then, they were asked to comment on the usefulness of each improvement. This represents a naturalistic evaluation since it was conducted using a real artifact in a real organization facing real problems.
- **When was it evaluated?** It was evaluated ex post (after the design artifact was developed).

Overall, the four principles from [10] were accomplished:

- **Abstraction:** the artifact can be applied to any organization. As the proposal focuses on DEMO and by consequence not considering the implementation details, it can be applied to organizations in different contexts, as demonstrated in other works [11] [12];
- **Originality:** the proposed artifact is not present in the body of knowledge of the domain since it was designed by relating independent subjects, such as best practices and DEMO;
- **Justification:** the artifact is supported by the related work, described by textual and graphical representations, and justified and validated in different ways;
- **Benefit:** the artifact provides a structured working approach for aligning the organizations processes with the corresponding best practices. The feedback from the ACME's employee was positive since he agreed with all the suggested improvements. He mentioned that after the application of this proposal it was possible to have a big picture of the studied process and its (mis)alignment with the ITIL best practices.

Despite these positive results, we also found some limitations. The most relevant is the fact that we only interviewed three "knowledge worker" from ACME involved in the customer complaint process. Although, being a crucial elements of the ACME team accountable for answering the customers' complaints, their feedback may not be representable of the entire team.

6 Conclusion

This research offers an alternative for the diagnosis and resolution of organizational problems with scientific bases, through Enterprise Ontology, DEMO and best practices. We seek to leverage the capability of organizations to align their operations with industry standards and frameworks. This is not trivial since current best practices do not provide methods based on strong conceptual foundations to support this alignment.

In this context, this research proposes a method that, by using a common language (DEMO) to describe organizations' processes and best practices, allows to compare

both and propose specific changes to the organizations' processes, so these can be aligned with the best practices. Therefore, the main contributions of this paper are: (1) leverage the use of best practices in organizations, and (2) create ontological models considered standard for a particular industry. These contributions promote the potential of applying Enterprise Ontology and DEMO in organizations.

As future work, we intend to apply our proposal in a different organization from the same industry in order to improve the ITIL ontological models. Additionally, we intend to evaluate the applicability of the method in different industries (health, bank, and public administration) and with different best practices (COBIT and CMMI).

References

- [1] Forrester, E.C., Buteau, B.L., Shrum, S.: *CMMI for Services: Guidelines for Superior Service*, 2nd edn. Addison-Wesley (2011)
- [2] Dietz, J.: *Enterprise Ontology - Theory and Methodology*. Springer (2006)
- [3] Hevner, A., March, S.T., Park, J., Ram, S.: *Design Science in Information Systems Research*. *MIS Quarterly* (2004)
- [4] Office of Government Commerce. *ITIL v3 – Service Operation*, The Stationery Office (2007b)
- [5] Henriques, M.: *Enterprise Governance and DEMO: Towards a reference method to guide the enterprise dynamics by addressing DEMO's competence, authority, and responsibility notions*. Master Thesis, Instituto Superior Técnico, University of Lisbon (2010)
- [6] Caetano, A., Assis, A., Tribolet, J.: *Using Business Transactions to Analyse the Consistency of Business Process Models*. In: Hawaii: 45th International Conference on, System Science (HICSS), pp. 4277–4285. IEEE (2012)
- [7] Womack, J., Jones, D.: *Lean thinking*. Simon & Schuster, London (2003)
- [8] Dias, D.G., Mendes, C., da Silva, M.M.: *A Method for Reengineering Healthcare Using Enterprise Ontology and Lean*. In: Fred, A., Dietz, J.L.G., Liu, K., Filipe, J. (eds.) *IC3K 2012*. CCIS, vol. 415, pp. 243–259. Springer, Heidelberg (2013)
- [9] Pries-Heje, J., Baskerville, R., Venable, J.: *Strategies for Design Science Research Evaluation*. In: 16th European Conference on Information Systems (ECIS), pp. 255–266 (2004)
- [10] Österle, H., Becker, J., Frank, U., Hess, T., Karagiannis, D., Krcmar, H., Loos, P., Mertens, P., Oberweis, A., Sinz, E.: *Memorandum on Design-Oriented Information Systems Research*. *European Journal on Information Systems* 10, 7–10 (2011)
- [11] Mendes, C., Almeida, M., Salvador, N., Mira da Silva, M.: *Using DEMO-based SLAs for Improving City Council Services, Barcelona, Spain*. In: 4th International Joint Conference on Knowledge Discovery, Knowledge Engineering and Knowledge Management - Special Session on Enterprise Ontology, Best Paper Award (2012)
- [12] Mendes, C., Mira da Silva, M.: *DEMO-Based Service Level Agreements*. In: Snene, M. (ed.) *IESS 2012*. LNBIP, vol. 103, pp. 227–242. Springer, Heidelberg (2012)
- [13] Assis, A.: *Analysis of Business Process Models based on Business-Action Theory and DEMO*. Master Thesis, Instituto Superior Técnico, University of Lisbon (2011)