

INTERACTION
OF MECHANICS
AND MATHEMATICS

KHANH CHAU LE
LU TRONG KHIEM NGUYEN

Energy Methods in Dynamics

Second Edition



Springer

Interaction of Mechanics and Mathematics

Series editor

Lev Truskinovsky, Laboratoire de Mécanique des Solides, Palaiseau, France
e-mail: trusk@lms.polytechnique.fr

For further volumes:

<http://www.springer.com/series/5395>

About this Series

The Interaction of Mechanics and Mathematics (IMM) series publishes advanced textbooks and introductory scientific monographs devoted to modern research in the wide area of mechanics. The authors are distinguished specialists with international reputation in their field of expertise. The books are intended to serve as modern guides in their fields and anticipated to be accessible to advanced graduate students. IMM books are planned to be comprehensive reviews developed to the cutting edge of their respective field and to list the major references.

Advisory Board

D. Colton, USA

R. Knops, UK

G. DelPiero, Italy

Z. Mroz, Poland

M. Slemrod, USA

S. Seelecke, USA

L. Truskinovsky, France

IMM is promoted under the auspices of ISIMM (International Society for the Interaction of Mechanics and Mathematics).

Khanh Chau Le · Lu Trong Khiem Nguyen

Energy Methods in Dynamics

Second Edition

 Springer

Khanh Chau Le
Ruhr Universität Bochum
Lehrstuhl für Mechanik und Material
Theorie
Bochum
Germany

Lu Trong Khiem Nguyen
Ruhr Universität Bochum
Lehrstuhl für Mechanik und Material
Theorie
Bochum
Germany

ISSN 1860-6245 ISSN 1860-6253 (electronic)
ISBN 978-3-319-05418-6 ISBN 978-3-319-05419-3 (eBook)
DOI 10.1007/978-3-319-05419-3
Springer Cham Heidelberg New York Dordrecht London

Library of Congress Control Number: 2014933546

© Springer International Publishing Switzerland 2011, 2014

This work is subject to copyright. All rights are reserved by the Publisher, whether the whole or part of the material is concerned, specifically the rights of translation, reprinting, reuse of illustrations, recitation, broadcasting, reproduction on microfilms or in any other physical way, and transmission or information storage and retrieval, electronic adaptation, computer software, or by similar or dissimilar methodology now known or hereafter developed. Exempted from this legal reservation are brief excerpts in connection with reviews or scholarly analysis or material supplied specifically for the purpose of being entered and executed on a computer system, for exclusive use by the purchaser of the work. Duplication of this publication or parts thereof is permitted only under the provisions of the Copyright Law of the Publisher's location, in its current version, and permission for use must always be obtained from Springer. Permissions for use may be obtained through RightsLink at the Copyright Clearance Center. Violations are liable to prosecution under the respective Copyright Law.

The use of general descriptive names, registered names, trademarks, service marks, etc. in this publication does not imply, even in the absence of a specific statement, that such names are exempt from the relevant protective laws and regulations and therefore free for general use.

While the advice and information in this book are believed to be true and accurate at the date of publication, neither the authors nor the editors nor the publisher can accept any legal responsibility for any errors or omissions that may be made. The publisher makes no warranty, express or implied, with respect to the material contained herein.

Printed on acid-free paper

Springer is part of Springer Science+Business Media (www.springer.com)



To Hoa, Ly, and Jan
To Khiem's parents

Preface to the Second Edition

Since the appearance of the first edition we have received various feedbacks and suggestions from students and teachers. To make the textbook more suitable for learning and teaching purposes, especially to show the energy and variational-asymptotic method “in action”, we decided to include the solutions to all exercises in this second edition (some of the exercises have been changed). Besides, we have found and corrected various small errors and misprints in the first edition. Finally, Section 8.4 is rewritten completely taking into account the new developments in amplitude and slope modulation of nonlinear dispersive waves. We would like to thank especially the editor of the series “Interaction of Mechanics and Mathematics”, L. Truskinovsky, for his various constructive suggestions. The interest and support of the publishing editor of Springer Verlag, Dr. T. Ditzinger, in this second edition is also gratefully acknowledged.

Bochum, November 2013
Khanh Chau Le
Lu Trong Khiem Nguyen

Preface to the First Edition

We live in the world surrounded by vibrations and waves. Some, such as sound, light, and electricity, are familiar companions in everyday life, while many others, such as lattice vibrations, vibrations of fluid particles in a turbulent flow, or vibrations of temperature about its average value, cannot be observed by naked eyes but can be measured by sensitive modern instruments. Vibrations and waves also dominate in the micro-world: vibrations of atoms, waves of elementary particles, and one would be remiss to fail to mention that the governing equation of quantum mechanics is the Schrödinger wave equation. Vibrations and waves find various applications in engineering and in our everyday life, from clocks, bells, lamps, musical instruments, to radio, television, laser, plasma, computer, internet etc. Sometimes vibrations and waves are not as harmless as one might think. Whoever lives near a highway or an airport knows, how annoying permanent noise can be. Medical techniques and high precision equipments often require vibration free frames which are not always easily realizable. The wings of airplane or the rotor blades of helicopter may encounter strong vibrations during exploitation causing their quick damage. Various catastrophes in the nature like earthquake or tsunami are also due to vibrations and waves.

The above examples should make clear the necessity of understanding the mechanism of vibrations and waves in order to control them in an optimal way. However, vibrations and waves are governed by differential equations which require, as a rule, rather complicated mathematical methods for their analysis. The aim of this textbook is to help students acquire both a good grasp of the first principles from which the governing equations can be derived, and the adequate mathematical methods for their solving. Its distinctive features, as seen from the title, lie in the systematic and intensive use of Hamilton's variational principle and its generalizations for deriving the governing equations of conservative and dissipative mechanical systems, and also in providing the direct variational-asymptotic analysis, whenever available, of the energy and dissipation for the solution of these equations. It will be demonstrated that many well-known methods in dynamics like those of Lindstedt-Poincaré, Bogoliubov-Mitropolsky, Kolmogorov-Arnold-Moser (KAM), and Whitham are derivable from this variational-asymptotic analysis.

This book grew up from the lectures given by the author in the last decade at the Ruhr University Bochum, Germany. Since vibrations and waves are constituents of various disciplines (physics, mechanics, electrical engineering etc.) and cannot be handled in a single textbook, I have restricted myself mainly to vibrations and waves of mechanical nature. Unfortunately, due to the time constraint I had to leave out the most exciting and quickly developing part of dynamics, namely the deterministic chaos. Chapter 7 can serve as an introduction to this fascinating topic. The material of this book can be recommended for a one year course in higher dynamics for graduate students of mechanical and civil engineering. For this circle of readers, the emphasis is made on the *constructive* methods of solution and not on the rigorous mathematical proofs of convergence. As compensation, various numerical simulations of the exact and approximate solutions are provided which demonstrate vividly the validity of the used methods. To help students become more proficient, each chapter ends with exercises, of which some can be solved effectively by using *Mathematica*.

I would like to thank first of all K. Hackl, who insisted that this one-year graduate course in higher dynamics at Ruhr University Bochum must be taught by me, and V. Berdichevsky, C. Günther, D. Hodges, M. Kaluza, R. Knops, G. Schmid, L. Truskinovsky, and many other friends and colleagues for their comments and useful discussions.

Bochum, May 2011
Khanh Chau Le

Contents

Part I: Linear Theory

1	Single Oscillator	3
1.1	Harmonic Oscillator	3
1.2	Damped Oscillator	9
1.3	Forced Oscillator	20
1.4	Harmonic Excitations and Resonance	26
1.5	Exercises	33
2	Coupled Oscillators	45
2.1	Conservative Oscillators	45
2.2	Dissipative Oscillators	52
2.3	Forced Oscillators and Vibration Control	59
2.4	Variational Principles	65
2.5	Oscillators with n Degrees of Freedom	70
2.6	Exercises	78
3	Continuous Oscillators	99
3.1	Chain of Oscillators	99
3.2	String	104
3.3	Beam	110
3.4	Membrane	114
3.5	Plate	120
3.6	General Continuous Oscillators	126
3.7	Exercises	135
4	Linear Waves	151
4.1	Hyperbolic Waves	151
4.2	Dispersive Waves	160
4.3	Elastic Waveguide	169
4.4	Energy Method	179
4.5	Exercises	188

Part II: Nonlinear Theory

5	Autonomous Single Oscillator	207
5.1	Conservative Oscillator	207
5.2	Dissipative Oscillator	215
5.3	Self-excited Oscillator	222
5.4	Oscillator with Weak or Strong Dissipation	232
5.5	Exercises	237
6	Non-autonomous Single Oscillator	255
6.1	Parametrically-Excited Oscillator	255
6.2	Mathieu's Differential Equation	263
6.3	Duffing's Forced Oscillator	268
6.4	Forced Vibration of Self-excited Oscillator	275
6.5	Exercises	282
7	Coupled Oscillators	297
7.1	Conservative Oscillators	297
7.2	Bifurcation of Nonlinear Normal Modes	305
7.3	KAM Theory	312
7.4	Coupled Self-excited Oscillators	320
7.5	Exercises	327
8	Nonlinear Waves	343
8.1	Solitary and Periodic Waves	343
8.2	Inverse Scattering Transform	350
8.3	Energy Method	359
8.4	Amplitude and Slope Modulation	368
8.5	Amplitude Modulations for KdV Equation	377
8.6	Exercises	389
	Notation	403
	References	405
	Index	409

Part I
Linear Theory

Chapter 1

Single Oscillator

This chapter deals with small vibrations of the simplest mechanical systems, namely of oscillators having only one degree of freedom. The most general and effective method of solution is the Laplace transform which is based entirely on the linear superposition principle.

1.1 Harmonic Oscillator

Differential Equation of Motion. The derivation of the equation of motion is the first, and at the same time, most responsible step toward solution of a real problem. Having derived the right equation, we have won already half the battle. In contrary, having arrived at some wrong equation, all of our further efforts in solving it will end in nothing but disaster. To derive the equation of motion we must

- idealize the real physical problem,
- apply the first principles of dynamics.

There are two equivalent methods of deriving the equation of motion based on the first principles of dynamics: the force method and the energy method. In the force method, we first free parts of the system under consideration from the surrounding, then draw the free-body diagram with all acting forces, and finally apply Newton's law to each degree of freedom. The energy method is based on Hamilton's variational principle leading to Lagrange's equations. Since we are dealing then with only one function, the energy method turns out to be simpler and much more effective, especially for systems with many degrees of freedom and with various constraints. In order to demonstrate their equivalence, let us begin with simple examples.

EXAMPLE 1.1. Mass-spring oscillator. A point-mass m moves horizontally under the action of a massless spring of stiffness k (see Fig. 1.1). Derive the equation of motion for this oscillator.

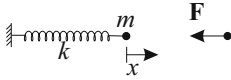

Fig. 1.1 Mass-spring oscillator

We see already in the formulation of the problem various idealizations of the real situation: the point-mass is considered instead of a body of finite size, this mass is constrained to move horizontally, the spring is regarded as massless and linearly elastic, the air resistance to motion through viscous damping is neglected etc. How close this simple mathematical model can describe the real physical problem is the

matter of experimental verification.

To use the force method we must first free the point-mass from the spring, then draw the free-body diagram (see Fig. 1.1, right), and finally apply Newton's second law (mass times acceleration = force) in the x -direction

$$m\ddot{x} = \sum F_x = -kx,$$

where the dot denotes the time derivative. Bringing the spring force $-kx$ to the left-hand side and dividing by m , we transform the equation of motion to the standard form

$$\ddot{x} + \omega_0^2 x = 0, \quad \omega_0 = \sqrt{\frac{k}{m}}. \quad (1.1)$$

The energy method is based on Hamilton's variational principle of least action¹ which states that, among all admissible motions $x(t)$ of the point-mass satisfying the initial and end conditions

$$x(t_0) = x_0, \quad x(t_1) = x_1,$$

the true motion is the extremal of the action functional

$$I[x(t)] = \int_{t_0}^{t_1} L(x, \dot{x}) dt.$$

The direct consequence of Hamilton's variational principle is Lagrange's equation (see the derivation in Section 2.4)

$$\frac{d}{dt} \frac{\partial L}{\partial \dot{x}} - \frac{\partial L}{\partial x} = 0.$$

Thus, all we need is a single function $L(x, \dot{x})$, called Lagrange function, which is given by

$$L(x, \dot{x}) = K(\dot{x}) - U(x),$$

where $K(\dot{x})$ is the kinetic energy and $U(x)$ the potential energy. As soon as we have it, the job is done, provided one knows how to differentiate functions. In our example

¹ See [21] and the detailed discussion in [29]. One may also read a curious and fascinating story of Feynman about how he learned Hamilton's principle of least action and tried later to *explain* it from the quantum mechanics and path integral in The Feynman Lectures on Physics [14].

$$K(\dot{x}) = \frac{1}{2}m\dot{x}^2, \quad U(x) = \frac{1}{2}kx^2.$$

Computing the partial derivatives of this Lagrange function

$$\frac{\partial L}{\partial \dot{x}} = m\dot{x}, \quad \frac{\partial L}{\partial x} = -kx,$$

and substituting them into Lagrange's equation, we obtain

$$m\ddot{x} + kx = 0,$$

which can again be reduced to the normal form (1.1).

EXAMPLE 1.2. Mathematical pendulum. A point-mass m , connected with a fixed support O by a rigid and massless bar of length l , rotates in the (x, y) -plane about O under the action of gravity (see Fig. 1.2). Derive the equation of motion for this pendulum.

We see that, again, several idealizations are made to simplify the real physical pendulum: the whole mass is concentrated in the point, the carrying bar is rigid and massless, the air resistance to motion through viscous damping is neglected.

In the force method we free the point-mass from the carrying bar, draw the free-body diagram and apply Newton's law in the tangential direction

$$ma_\tau = \sum F_\tau = -mg \sin \varphi.$$

The force of the bar acting on the point-mass does not contribute to this equation because it is in the radial direction. Substituting the tangential acceleration $a_\tau = l\ddot{\varphi}$ into this equation, bringing the force term $-mg \sin \varphi$ to the left-hand side, and dividing by ml , we obtain

$$\ddot{\varphi} + \omega_0^2 \sin \varphi = 0, \quad \omega_0 = \sqrt{\frac{g}{l}}.$$

For small vibrations the angle φ (measured in radian) is small compared with 1, so we can linearize this equation by approximating $\sin \varphi \approx \varphi$ to obtain

$$\ddot{\varphi} + \omega_0^2 \varphi = 0, \tag{1.2}$$

which is identical in form with equation (1.1).

Alternatively, one can free the point-mass together with the rigid bar from the support and apply the moment equation about the z -axis (which is the consequence of Newton's law) to this system

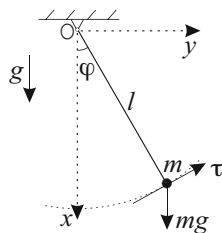

Fig. 1.2 Mathematical pendulum

$$\frac{d}{dt}(ml^2\dot{\varphi}) = \sum M_z = -mgl \sin \varphi.$$

Since the mass is concentrated in the point, its moment of inertia about O is ml^2 . In case of a real physical pendulum (rotation of a body about O) the moment of inertia about O is given by $J_O = J_S + mr^2$, where J_S is the moment of inertia about the center of mass S, and r the distance between O and S (see exercise 1.2). The support reaction in O does not contribute to the moment equation, because its line of action goes through O. For small vibrations we obtain from here equation (1.2).

To use the energy method we write down the kinetic energy

$$K(\dot{\varphi}) = \frac{1}{2}ml^2\dot{\varphi}^2,$$

and the potential energy

$$U(\varphi) = mgh = mgl(1 - \cos \varphi).$$

Note that the zero level of potential energy (which can be chosen arbitrarily) corresponds to the equilibrium state $\varphi = 0$. Thus, the Lagrange function is

$$L(\varphi, \dot{\varphi}) = \frac{1}{2}ml^2\dot{\varphi}^2 - mgl(1 - \cos \varphi).$$

For small vibrations $\varphi \ll 1$, therefore we can approximate $1 - \cos \varphi \approx \varphi^2/2$ and write

$$L(\varphi, \dot{\varphi}) = \frac{1}{2}ml^2\dot{\varphi}^2 - \frac{1}{2}mgl\varphi^2.$$

Substituting this into Lagrange's equation

$$\frac{d}{dt} \frac{\partial L}{\partial \dot{\varphi}} - \frac{\partial L}{\partial \varphi} = 0,$$

we obtain again the equation of motion of mathematical pendulum.

EXAMPLE 1.3. Rotating disk. A rigid disk rotates about the z -axis under the action of a spiral spring of stiffness k (see Fig. 1.3). Derive the equation of motion of the disk.

This example represents a primitive model of a mechanical clock. In the force method we free the disk and the rotation axis from the supports and the spiral spring, draw the free-body diagram, and apply the moment equation about the z -axis

$$\frac{d}{dt}(J_z\dot{\varphi}) = \sum M_z = -k\varphi, \tag{1.3}$$

where J_z is the moment of inertia of the system disk plus rotation axis about the z -axis. The reaction forces from the supports do not contribute to this moment equation because their lines of action cut the z -axis. Bringing the spring moment $-k\varphi$ to the left-hand side and dividing by J_z , we obtain equation (1.2), where $\omega_0^2 = k/J_z$.

To use the energy method we write

$$K(\dot{\varphi}) = \frac{1}{2}J_z\dot{\varphi}^2, \quad U(\varphi) = \frac{1}{2}k\varphi^2$$

for the kinetic and potential energies, respectively. This leads again to (1.3).

Solution. Note that the equation of motion of harmonic oscillator

$$\ddot{x} + \omega_0^2 x = 0 \quad (1.4)$$

is linear. So, if we know two linearly independent particular solutions of this equation, then we can construct the general solution by their linear combination in accordance with the superposition principle. It is easy to check that

$$\cos \omega_0 t \quad \text{and} \quad \sin \omega_0 t$$

are the particular solutions of (1.4). Therefore the general solution reads

$$x(t) = A \cos \omega_0 t + B \sin \omega_0 t. \quad (1.5)$$

The unknown coefficients A and B must be found from the initial conditions

$$x(0) = x_0, \quad \dot{x}(0) = v_0.$$

Thus,

$$A = x_0, \quad B = \frac{v_0}{\omega_0}.$$

Alternatively, we can present the solution in form of one harmonic cosine function

$$x(t) = a \cos(\omega_0 t - \phi). \quad (1.6)$$

In this form a has the meaning of the amplitude of vibration, ω_0 the eigenfrequency, and ϕ the initial phase. Using the addition formula for $\cos(\omega_0 t - \phi)$ we write

$$x(t) = a(\cos \phi \cos \omega_0 t + \sin \phi \sin \omega_0 t).$$

Comparing this with (1.5), we find the relations between a , ϕ and A , B

$$a = \sqrt{A^2 + B^2} = \sqrt{x_0^2 + \frac{v_0^2}{\omega_0^2}}, \quad \tan \phi = \frac{B}{A} = \frac{v_0}{x_0 \omega_0}.$$

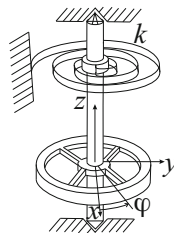

Fig. 1.3 Rotating disk

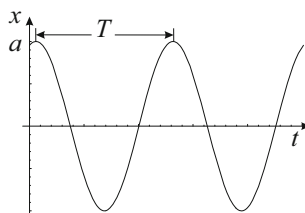

Fig. 1.4 Harmonic motion

Fig. 1.4 shows the graph of $x(t)$. The distance between two neighboring maxima (or minima) of this periodic function is called a period T of vibration. Since the period of cosine is 2π ,

$$T = \frac{2\pi}{\omega_0}.$$

Phase Portrait. Let the velocity \dot{x} be denoted by

$$y = \dot{x}.$$

Then each state of a single oscillator at fixed t corresponds to one point (x, y) of the so-called phase plane. As t changes this point moves in the phase plane along the curve called a phase curve. For the free vibration of harmonic oscillator we have from (1.6)

$$x = a \cos(\omega_0 t - \phi), \quad y = \dot{x} = -a\omega_0 \sin(\omega_0 t - \phi). \quad (1.7)$$

Consequently, the phase curves satisfy the equation

$$\frac{x^2}{a^2} + \frac{y^2}{a^2\omega_0^2} = 1, \quad (1.8)$$

which describes ellipses with the aspect ratio $1 : \omega_0$. Note that (1.8) can also be obtained from the conservation of energy

$$K(\dot{x}) + U(x) = E_0, \quad (1.9)$$

which is the consequence of Lagrange's equation (see Section 2.4). Indeed, consider for example the mass-spring oscillator for which the energy conservation takes the form

$$\frac{1}{2}m\dot{x}^2 + \frac{1}{2}kx^2 = \frac{1}{2}mv_0^2 + \frac{1}{2}kx_0^2 = \frac{ka^2}{2}.$$

Dividing this equation by the constant on the right-hand side, we arrive again at (1.8). With (1.8) we can express $y = \dot{x}$ in terms of x and integrate it to obtain the solution (1.6).

Fig. 1.5 shows the phase curves of the harmonic oscillator. In general there is no more than one phase curve passing through a given point of the phase plane. Since $y = \dot{x} > 0$ in the upper half-plane and $y = \dot{x} < 0$ in the lower half-plane, the phase curves must run from left to right in the upper half-plane and from right to left in the lower half-plane as time increases. All phase curves cut the x -axis at right angle, with points of intersection corresponding to maxima or minima of $x(t)$ which are

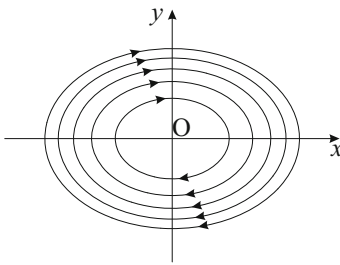

Fig. 1.5 Phase portrait of harmonic oscillator

the turning points. The origin O of the phase plane is the fixed point corresponding to the stable equilibrium state. For the harmonic oscillator this fixed point is called a center.

Energy Balance. As we see from (1.9), the total energy of the harmonic oscillator is conserved. Let us analyze the change of its kinetic and potential energies during the vibration. Substituting $x(t)$ from (1.7) into the potential energy $U(x)$, we get

$$U(x) = \frac{1}{2}kx^2 = \frac{ka^2}{2} \cos^2(\omega_0 t - \phi) = \frac{ka^2}{4} [1 + \cos(2\omega_0 t - 2\phi)].$$

Similarly, with $\dot{x}(t)$ from (1.7) we obtain

$$K(\dot{x}) = \frac{1}{2}m\dot{x}^2 = \frac{ma^2\omega_0^2}{2} \sin^2(\omega_0 t - \phi) = \frac{ka^2}{4} [1 - \cos(2\omega_0 t - 2\phi)].$$

Thus, the kinetic and potential energies oscillate with the same amplitude which is equal to the total energy $E_0 = ka^2/2$, but with the double frequency $2\omega_0$. Fig. 1.6 shows the change of kinetic and potential energies from which it is seen that they oscillate in counter-phases so that their sum remains constant, in full agreement with the conservation of energy.

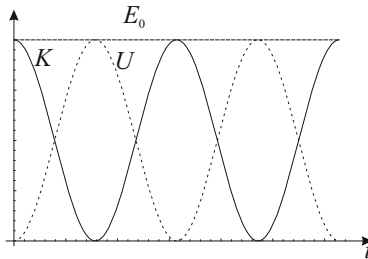

Fig. 1.6 Energy change: a) bold line: kinetic energy, b) dashed line: potential energy, c) horizontal line: total energy

1.2 Damped Oscillator

Differential Equation of Motion. Both the force and the energy methods can again be applied to derive the equation of motion for damped oscillators. However, in the energy method a new function describing the dissipation potential of the damper has to be introduced. We consider two examples.

EXAMPLE 1.4. Mass-spring-damper oscillator. A mass m moves horizontally under the action of a spring of stiffness k and a damper with a damping constant c (see Fig. 1.7). Derive the equation of motion for this oscillator.

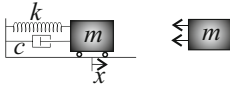

Fig. 1.7 Mass-spring-damper oscillator

To apply the force method we note that the only difference compared with example 1.1 is the additional force from the damper which is proportional to the velocity \dot{x} (see the free-body diagram in Fig. 1.7, right). Thus, Newton's law now reads

$$m\ddot{x} = \sum F_x = -kx - c\dot{x}.$$

Bringing the two terms on the right-hand side to the left-hand side, we obtain

$$m\ddot{x} + c\dot{x} + kx = 0. \quad (1.10)$$

The energy method is based on the following variational principle for dissipative systems: among all admissible motions $x(t)$ constrained by the initial and end conditions

$$x(t_0) = x_0, \quad x(t_1) = x_1,$$

the true motion satisfies the variational equation²

$$\delta \int_{t_0}^{t_1} L(x, \dot{x}) dt - \int_{t_0}^{t_1} \frac{\partial D}{\partial \dot{x}} \delta x dt = 0. \quad (1.11)$$

Thus, a new function $D(x, \dot{x})$, called dissipation function, appears such that the damping force f_r is expressed by

$$f_r = -c\dot{x} = -\frac{\partial D}{\partial \dot{x}}.$$

The direct consequence of (1.11) is modified Lagrange's equation for dissipative systems (see Section 2.4)

$$\frac{d}{dt} \frac{\partial L}{\partial \dot{x}} - \frac{\partial L}{\partial x} + \frac{\partial D}{\partial \dot{x}} = 0. \quad (1.12)$$

We see that the behavior of any dissipative mechanical system is governed by two functions, namely, the Lagrange function $L(x, \dot{x})$ and the dissipation function $D(x, \dot{x})$. In our example

² This variational equation originates from d'Alembert's principle in dynamics [8,29], where the last term corresponds to the virtual work done by the damping force expressed in terms of the dissipation function [45].

$$L = \frac{1}{2}m\dot{x}^2 - \frac{1}{2}kx^2, \quad D = \frac{1}{2}c\dot{x}^2,$$

so, substituting this into (1.12), we derive again the equation of motion (1.10).

EXAMPLE 1.5. Mathematical pendulum with spring and damper. Derive the equation of small vibration for the mathematical pendulum connected with a spring and a damper (see Fig. 1.8).

This model is equivalent to that of the pendulum with the spring and with the air resistance since, in reality, the air acts as a damper with viscous damping. In the force method we must add the forces of spring and damper to the free-body diagram compared with that of the mathematical pendulum in example 1.2. Taking into account the smallness of φ , the moment equation about the z -axis reads

$$ml^2 \ddot{\varphi} = \sum M_z = -mgl\varphi - k\frac{l^2}{4}\varphi - cl^2\dot{\varphi}.$$

Bringing all terms to the left-hand side and dividing by l^2 , we get

$$m\ddot{\varphi} + c\dot{\varphi} + \left(\frac{mg}{l} + \frac{k}{4}\right)\varphi = 0. \quad (1.13)$$

This is identical in form with equation (1.10).

To use the energy method we must include in the Lagrange function already found in example 1.2 for small vibrations an additional term associated with the energy of the spring

$$L(\varphi, \dot{\varphi}) = \frac{1}{2}ml^2\dot{\varphi}^2 - \frac{1}{2}mgl\varphi^2 - \frac{1}{2}k\left(\frac{l\varphi}{2}\right)^2.$$

Here, the change in length of the spring, due to the smallness of φ , is approximated by $l\varphi/2$ (see Fig. 1.8). The dissipation function must be a quadratic function of the velocity $l\dot{\varphi}$

$$D(\dot{\varphi}) = \frac{1}{2}c(l\dot{\varphi})^2 = \frac{1}{2}cl^2(\dot{\varphi})^2.$$

Substituting these formulas into modified Lagrange's equation for dissipative systems

$$\frac{d}{dt} \frac{\partial L}{\partial \dot{\varphi}} - \frac{\partial L}{\partial \varphi} + \frac{\partial D}{\partial \dot{\varphi}} = 0,$$

we derive the equation

$$ml^2 \ddot{\varphi} + cl^2 \dot{\varphi} + (mgl + k\frac{l^2}{4})\varphi = 0,$$

which, after division by l^2 , takes the form (1.13).

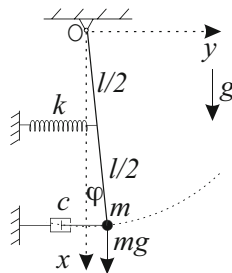

Fig. 1.8 Spring-damper-pendulum

Reduction to the Standard Form. Let us divide the equation of motion (1.10) by k

$$\frac{1}{\omega_0^2} \ddot{x} + \frac{c}{k} \dot{x} + x = 0, \quad \omega_0 = \sqrt{\frac{k}{m}}. \quad (1.14)$$

We introduce now the dimensionless time $\tau = \omega_0 t$, in terms of which the first and second derivatives of x become

$$\begin{aligned} \dot{x} &= \frac{dx}{dt} = \frac{dx}{d\tau} \frac{d\tau}{dt} = \omega_0 x', \\ \ddot{x} &= \frac{d\dot{x}}{dt} = \frac{d\dot{x}}{d\tau} \frac{d\tau}{dt} = \omega_0^2 x''. \end{aligned}$$

Here the prime denotes the derivative with respect to τ . Substituting these formulas into (1.14), we obtain the equation of motion in standard form

$$x'' + 2\delta x' + x = 0, \quad (1.15)$$

where the positive coefficient

$$\delta = \frac{c\omega_0}{2k} = \frac{c}{2m\omega_0} = \frac{c}{2\sqrt{km}}$$

is called Lehr's damping ratio.

Solution. We seek a particular solution of (1.15) in the form

$$x = e^{s\tau}.$$

Substituting this Ansatz into (1.15)

$$(s^2 + 2\delta s + 1)e^{s\tau} = 0,$$

we see that, since the factor $e^{s\tau}$ is not equal to zero, s must satisfy the characteristic equation

$$s^2 + 2\delta s + 1 = 0. \quad (1.16)$$

The quadratic equation (1.16) has two roots

$$s_{1,2} = -\delta \pm \sqrt{\delta^2 - 1}.$$

The character of roots and consequently of the solutions depends on whether a) $0 < \delta < 1$, b) $\delta > 1$, or c) $\delta = 1$. We analyze now these special cases.

Case a. Since $0 < \delta < 1$, we set $1 - \delta^2 = \nu^2 > 0$. In this case the roots are complex-conjugate

$$s_{1,2} = -\delta \pm i\nu.$$

Because $e^{s\tau} = e^{-\delta\tau} e^{i\nu\tau}$ satisfies (1.15) which is the differential equation with real coefficients, its real and imaginary parts

$$e^{-\delta\tau} \cos \nu\tau \quad \text{and} \quad e^{-\delta\tau} \sin \nu\tau$$

also satisfy this equation. The general solution can now be constructed using the linear superposition principle

$$x = e^{-\delta\tau}(A \cos \nu\tau + B \sin \nu\tau).$$

The unknown coefficients A and B must be found from the initial conditions

$$x(0) = x_0, \quad x'(0) = x'_0. \quad (1.17)$$

Thus,

$$A = x_0, \quad B = \frac{x'_0 + \delta x_0}{\nu}.$$

Alternatively, we can present the solution in the form

$$x = a_0 e^{-\delta\tau} \cos(\nu\tau - \phi). \quad (1.18)$$

Using the addition theorem for $\cos(\nu\tau - \phi)$, we then find that

$$a_0 = \sqrt{A^2 + B^2} = \sqrt{x_0^2 + \frac{(x'_0 + \delta x_0)^2}{\nu^2}}, \quad \tan \phi = \frac{B}{A} = \frac{x'_0 + \delta x_0}{\nu x_0}.$$

Case b. Because now $\delta > 1$, we set $\delta^2 - 1 = \kappa^2 > 0$. Thus, there are two real roots of (1.16)

$$s_1 = -\delta + \kappa = -q_1, \quad s_2 = -\delta - \kappa = -q_2,$$

where $q_2 > q_1 > 0$. The corresponding particular solutions of (1.15) are

$$e^{-q_1\tau} \quad \text{and} \quad e^{-q_2\tau}.$$

The general solution reads

$$x = Ae^{-q_1\tau} + Be^{-q_2\tau}.$$

Then the initial conditions (1.17) lead to

$$A = \frac{1}{2\kappa}(x'_0 + q_2 x_0), \quad B = -\frac{1}{2\kappa}(x'_0 + q_1 x_0).$$

Thus,

$$x = \frac{1}{2\kappa}[(x'_0 + q_2 x_0)e^{-q_1\tau} - (x'_0 + q_1 x_0)e^{-q_2\tau}]. \quad (1.19)$$

Case c. This is the degenerate case, where the real roots are equal (the double real root): $s_1 = s_2 = -\delta = -1$. According to the theory of ordinary differential equations [11] the particular solutions should be $e^{-\tau}$ and $\tau e^{-\tau}$. Combining them, we obtain the general solution in the form

$$x = e^{-\tau}(A\tau + B).$$

The initial conditions (1.17) yield

$$A = x_0 + x'_0, \quad B = x_0.$$

Thus,

$$x = e^{-\tau}[x_0(1 + \tau) + x'_0\tau].$$

Behavior. Having found the solutions in these cases, we can now study their behaviors.

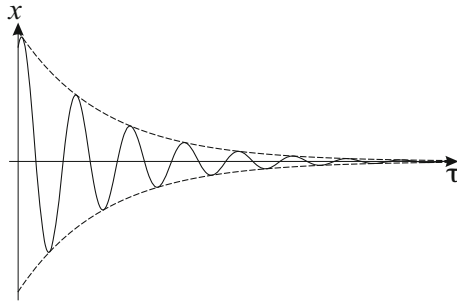

Fig. 1.9 Solid line: motion $x = a_0e^{-\delta\tau} \cos(\nu\tau - \phi)$, dashed lines: envelopes $x = \pm a_0e^{-\delta\tau}$

Case a. The motion is classified as damped vibration. Fig. 1.9 shows the plot of $x(\tau)$ (the solid line). Since $|\cos(\nu\tau - \phi)| \leq 1$, the motion oscillates between two envelopes $x = \pm a_0e^{-\delta\tau}$ drawn by the dashed lines in this Figure. Looking at this motion we can recognize two characteristic dimensionless time scales

$$\tau_d = \frac{1}{\delta} \quad \text{and} \quad \tau_c = \frac{2\pi}{\nu} = \frac{2\pi}{\sqrt{1 - \delta^2}},$$

or, in the dimension of real time

$$T_d = \frac{1}{\delta\omega_0} = \frac{2m}{c} \quad \text{and} \quad T_c = \frac{2\pi}{\omega_c} = \frac{2\pi}{\omega_0\sqrt{1 - \delta^2}} = \frac{T_0}{\sqrt{1 - \delta^2}}.$$

The time scale τ_d characterizes the decay rate of amplitude due to damping: the exponent function $e^{-\delta\tau}$ decays after τ_d by the factor $1/e \approx 0,368$, the amplitude of vibration diminishes by 63%. The time scale τ_c tells us about the so-called conditional period T_c of vibration, which is larger (by the factor $1/\sqrt{1 - \delta^2}$) than the period T_0 of the corresponding harmonic oscillator.

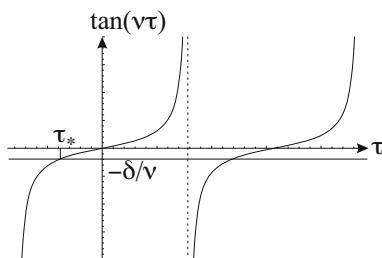

Fig. 1.10 Roots of equation $\tan v\tau = -\delta/v$

The distance between zeros of $x(\tau)$ (the roots of $\cos(v\tau - \phi) = 0$) is π/v . The points at which $x(\tau)$ touches the envelopes correspond to the roots of the equations

$$\cos(v\tau - \phi) = \pm 1.$$

Thus, they lie in the middle between zeros. However these points are not identical with the points at which maxima or minima of $x(\tau)$ are achieved. Its maxima or minima are achieved at time instants satisfying the equation

$$x'(\tau) = -a_0\delta e^{-\delta\tau} \cos(v\tau - \phi) - a_0ve^{-\delta\tau} \sin(v\tau - \phi) = 0,$$

so, they are roots of the equation $\tan(v\tau - \phi) = -\delta/v$. Assuming for simplicity $\phi = 0$, we find that these roots are displaced from the zeros of the function $\tan v\tau$ to the left by the constant amount

$$\tau_* = \arctan(\delta/v)/v \quad (1.20)$$

on the τ -axis (see Fig. 1.10). Thus, the conditional period of vibration can be read off also from the distance between two maxima or minima.

There is another important characteristic of amplitude decay which can easily be measured by the oscillograph. To introduce it we denote by

$$x_1, x_2, \dots, x_n, \dots$$

the maxima of $x(\tau)$, and by

$$\tau_1, \tau_2, \dots, \tau_n, \dots$$

the corresponding time instants, at which these maxima are achieved. From the behavior of solution we know that

$$\begin{aligned} x_n &= a_0 e^{-\delta\tau_n} \cos(v\tau_n - \phi), \\ x_{n+1} &= a_0 e^{-\delta(\tau_n + \tau_c)} \cos[v(\tau_n + \tau_c) - \phi]. \end{aligned}$$

Dividing x_n by x_{n+1} and using the periodicity of cosine function, we get

$$\frac{x_n}{x_{n+1}} = e^{\delta\tau_c}.$$

We define

$$\vartheta = \ln \frac{x_n}{x_{n+1}} = \delta\tau_c = \frac{2\pi\delta}{\sqrt{1-\delta^2}}$$

as a logarithmic decrement of vibration. Knowing ϑ from measurements we can restore the damping ratio δ according to

$$\delta = \frac{\vartheta}{\sqrt{4\pi^2 + \vartheta^2}}.$$

Case b. The motion is overdamped and loses the oscillatory character (it is called therefore an aperiodic motion). The decay rates of exponential functions $e^{-q_1\tau}$ and $e^{-q_2\tau}$ to zero are characterized by two time scales

$$\tau_{d1} = \frac{1}{q_1} = \frac{1}{\delta - \kappa} \quad \text{and} \quad \tau_{d2} = \frac{1}{q_2} = \frac{1}{\delta + \kappa}.$$

To recognize the aperiodic character of motion let us find the instants of time, τ_1 and τ_2 , at which $x(\tau_1) = 0$ and $x'(\tau_2) = 0$, respectively. Using (1.19), we derive the following equations for τ_1 and τ_2 :

$$e^{2\kappa\tau_1} = 1 - \frac{2\kappa x_0}{x'_0 + q_2 x_0},$$

$$e^{2\kappa\tau_2} = 1 + \frac{2\kappa x'_0}{q_1(x'_0 + q_2 x_0)}.$$

Since the exponent is a monotonic function, we see that each equation has no more than one root. Thus, oscillatory motion is impossible. If we fix the initial coordinate x_0 and variate the initial velocity x'_0 , then the solution may have different behaviors depending on the initial velocity as shown in Fig. 1.11.

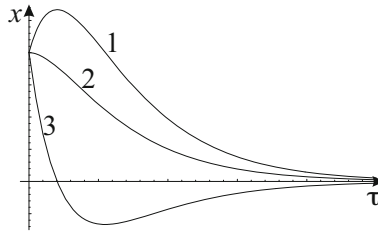

Fig. 1.11 Different aperiodic motions: 1) one root τ_2 , 2) no roots for τ_1 and τ_2 (monotone decreasing function $x(\tau)$), 3) one root for τ_1 and τ_2

Case c. This is the limiting case of aperiodic motion. The behavior is similar to the previous case.

Phase Portrait. The phase portraits exhibit different characters in the above cases.

Case a. To find the phase curves in the phase plane (x, y) , $y = x'$, we transform the equation of motion in standard form (1.15) to the system of first-order differential equations

$$x' = y, \quad y' = -x - 2\delta y.$$

Thus, the tangent vector to the phase curve at point (x, y) is $(y, -x - 2\delta y)$. Fig. 1.12 shows the vector field $(y, -x - 2\delta y)$ and one phase curve in the phase plane for $\delta = 0.1$.

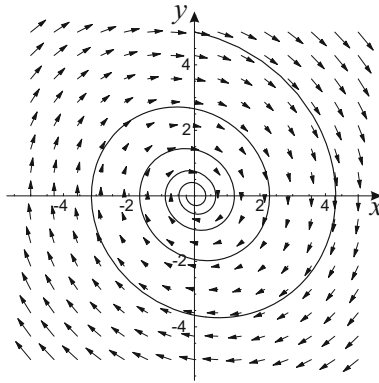

Fig. 1.12 Vector field $(y, -x - 2\delta y)$ and a phase curve

We derive the equation for the phase curves from the solution

$$\begin{aligned} x &= a_0 e^{-\delta\tau} \cos(v\tau - \phi), \\ x' &= -a_0 e^{-\delta\tau} [\delta \cos(v\tau - \phi) + v \sin(v\tau - \phi)]. \end{aligned}$$

Introducing

$$u = vx, \quad v = x' + \delta x, \tag{1.21}$$

we obtain

$$u = a_1 e^{-\delta\tau} \cos(v\tau - \phi), \quad v = -a_1 e^{-\delta\tau} \sin(v\tau - \phi),$$

where $a_1 = va_0$. In terms of the polar coordinates ρ and ϑ

$$u = \rho \cos \vartheta, \quad v = \rho \sin \vartheta,$$

these equations become

$$\rho = a_1 e^{-\delta\tau}, \quad \vartheta = -v\tau + \phi.$$

Expressing τ through ϑ by $\tau = -\frac{1}{v}(\vartheta - \phi)$, we obtain finally

$$\rho = a_1 e^{\delta\vartheta/v} e^{-\delta\phi/v} = a_2 e^{\delta\vartheta/v}, \quad (1.22)$$

where $a_2 = a_1 e^{-\delta\phi/v}$. Equation (1.22) describes the family of logarithmic spirals in the (u, v) -plane. As τ increases, ϑ decreases and the spirals approach the origin.

Coming back to the original coordinates x and y , we have

$$\begin{aligned} \rho^2 = u^2 + v^2 &= v^2 x^2 + (y + \delta x)^2 = y^2 + 2\delta xy + x^2, \\ \vartheta &= \arctan \frac{v}{u} = \arctan \frac{y + \delta x}{vx}. \end{aligned}$$

Thus, the equation of phase curves in terms of x and y reads

$$y^2 + 2\delta xy + x^2 = a_2^2 e^{2\frac{\delta}{v} \arctan \frac{y+\delta x}{vx}}.$$

Since the transformation (1.21) from (u, v) to (x, y) is linear, this equation also describes the logarithmic spirals in the (x, y) -plane. All spirals approach the origin as τ goes to infinity. The origin is a fixed point called a (stable) focus.

Case b. To derive the equation of phase curves in the phase plane we use the solution

$$\begin{aligned} x &= Ae^{-q_1\tau} + Be^{-q_2\tau}, \\ y = x' &= -q_1 Ae^{-q_1\tau} - q_2 Be^{-q_2\tau}. \end{aligned}$$

Thus, their linear combinations give

$$y + q_1 x = (q_1 - q_2)Be^{-q_2\tau}, \quad y + q_2 x = (q_2 - q_1)Ae^{-q_1\tau}.$$

Raising the first equation to the power q_1 and the second to the power q_2 and comparing them, we obtain

$$(y + q_1 x)^{q_1} = C(y + q_2 x)^{q_2}.$$

This is the equation of the phase curves in the (x, y) -plane. Introducing the new variables

$$u = y + q_2 x, \quad v = y + q_1 x, \quad (1.23)$$

we can rewrite the equation of the phase curves in the form

$$v = Cu^\alpha, \quad \alpha = \frac{q_2}{q_1} > 1.$$

This equation describes the family of power functions Cu^α (with $\alpha > 1$) in the (u, v) -plane (see Fig. 1.13 on the left). The linear transformation (1.23) transforms the u - and v -axis to the straight lines $y + q_1 x = 0$ and $y + q_2 x = 0$ in the (x, y) -plane.

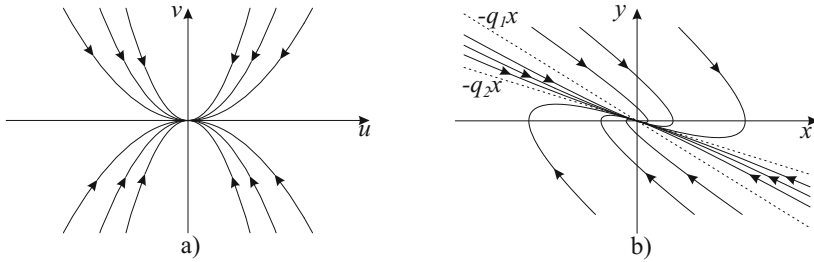

Fig. 1.13 Phase portrait of overdamped oscillator in: a) (u, v) -plane, b) (x, y) -plane

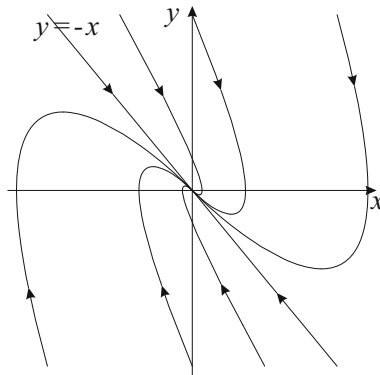

Fig. 1.14 Phase portrait of critically damped oscillator in (x, y) -plane

The phase curves in the (x, y) -plane are shown in Fig. 1.13 on the right. Similar to the previous case all phase curves approach the origin as τ tends to infinity. The origin is a fixed point called a (stable) node.

Case c. This is the degenerate case of aperiodic motion. Since $q_1 = q_2 = 1$, the two axes $y + q_2x = 0$ and $y + q_1x = 0$ coincide with the bisector $y = -x$. The phase curves in the (x, y) -plane are shown in Fig. 1.14. Similar to the previous case all phase curves approach the origin as τ tends to infinity.

Since Lehr's damping ratio δ is given by $\delta = c/2m\omega_0$, equation $\delta = 1$ describes the parabola $c/m = 2\sqrt{k/m}$ in the $(k/m, c/m)$ -plane of parameters. The latter is the boundary between different types of motion considered above as shown in Fig. 1.15.

Energy Balance. Because of the presence of damper in the system, the energy is no longer conserved. The initial energy will be dissipated gradually by the damper into heat, and the motion decays as time increases. As time goes to infinity, the initial energy will be dissipated completely, and the system approaches equilibrium. To find the rate of decay of the total energy we multiply modified Lagrange's equation (1.12) by \dot{x}

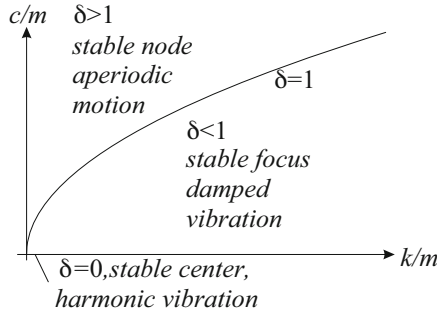

Fig. 1.15 Classification of motion in the $(k/m, c/m)$ -plane

$$\dot{x} \frac{d}{dt} \frac{\partial L}{\partial \dot{x}} - \dot{x} \frac{\partial L}{\partial x} = - \frac{\partial D}{\partial \dot{x}} \dot{x}.$$

Observing that

$$\begin{aligned} \dot{x} \frac{d}{dt} \frac{\partial L}{\partial \dot{x}} &= \dot{x} \frac{d}{dt} \frac{\partial K}{\partial \dot{x}} = m \dot{x} \ddot{x} = \frac{d}{dt} \left(\frac{1}{2} m \dot{x}^2 \right) = \frac{dK}{dt}, \\ - \dot{x} \frac{\partial L}{\partial x} &= \dot{x} \frac{\partial U}{\partial x} = \frac{dU}{dt}, \\ - \frac{\partial D}{\partial \dot{x}} \dot{x} &= -c \dot{x}^2 = -2D(\dot{x}), \end{aligned}$$

we obtain the energy dissipation rate in the form

$$\frac{d}{dt} (K + U) = -2D(\dot{x}). \quad (1.24)$$

A similar equation also holds true for oscillators with many degrees of freedom (see Section 2.4). Integrating equation (1.24) from t_0 to t , we find the energy change at time t

$$K + U - E_0 = -2 \int_{t_0}^t D(\dot{x}(s)) ds = -E_d(t),$$

where E_0 is the total energy at $t = t_0$ and $E_d(t)$ the amount of energy dissipated by the damper at time t .

1.3 Forced Oscillator

Differential Equation of Motion. If there is an additional external force (excitation) acting on the oscillator, the latter is called a forced oscillator. Also in this case both the force and the energy methods can be used to derive the equation of motion. In the energy method the virtual work done by the external force must be taken into account. We consider an example.

EXAMPLE 1.6. Mass-spring-damper forced oscillator. A mass m , connected with a spring of stiffness k and a damper of damping constant c , moves horizontally under the action of an external force $f(t)$ (see Fig. 1.16). Derive the equation of motion for this forced oscillator.

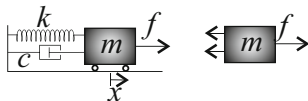

Fig. 1.16 Mass-spring-damper forced oscillator

In the force method the only difference compared with example 1.4 is the external force $f(t)$ (see the free-body diagram in Fig. 1.16). Thus, Newton's law in the x -direction reads

$$m\ddot{x} = \sum F_x = -kx - c\dot{x} + f(t).$$

Bringing the spring and damping forces to the left-hand side, we obtain

$$m\ddot{x} + c\dot{x} + kx = f(t). \quad (1.25)$$

To use the energy method we must add to the left-hand side of variational equation (1.11) the virtual work done by the external force. The variational principle becomes: among all admissible motions $x(t)$ constrained by the conditions

$$x(t_0) = x_0, \quad x(t_1) = x_1,$$

the true motion satisfies the variational equation (see the footnote on page 10)

$$\delta \int_{t_0}^{t_1} L(x, \dot{x}) dt - \int_{t_0}^{t_1} \frac{\partial D}{\partial \dot{x}} \delta x dt + \int_{t_0}^{t_1} f(t) \delta x dt = 0. \quad (1.26)$$

Note that the last integral representing the virtual work of external force can also be included in the first integral as follows

$$\delta \int_{t_0}^{t_1} [L(x, \dot{x}) + f(t)x] dt - \int_{t_0}^{t_1} \frac{\partial D}{\partial \dot{x}} \delta x dt = 0.$$

From (1.26) we can derive modified Lagrange's equation

$$\frac{d}{dt} \frac{\partial L}{\partial \dot{x}} - \frac{\partial L}{\partial x} + \frac{\partial D}{\partial \dot{x}} = f(t). \quad (1.27)$$

With

$$L(x, \dot{x}) = \frac{1}{2}m\dot{x}^2 - \frac{1}{2}kx^2, \quad D(\dot{x}) = \frac{1}{2}c\dot{x}^2,$$

we arrive again at the equation of motion (1.25).

Reduction to the Standard Form. Let us divide equation (1.25) by k

$$\frac{1}{\omega_0^2} \ddot{x} + \frac{c}{k} \dot{x} + x = \frac{f(t)}{k}.$$

Introducing the dimensionless time $\tau = \omega_0 t$ as in the previous Section, we transform this equation to the standard form

$$x'' + 2\delta x' + x = g(\tau), \quad (1.28)$$

where the prime denotes as before the derivative with respect to τ and $g(\tau) = f(\tau/\omega_0)/k$. Equation (1.28) is the inhomogeneous linear differential equation of second order. According to the theory of ordinary differential equations [11] the solution of this linear equation is the sum of any particular solution of the inhomogeneous equation and the general solution of the homogeneous equation which has been found in the previous Section. Thus, the problem reduces to finding any particular solution of the inhomogeneous equation (1.28).

Particular Solution for a Step Function. Consider first a special excitation in form of the unit step (Heaviside) function

$$g(\tau) = h(\tau) = \begin{cases} 0 & \text{for } \tau \leq 0, \\ 1 & \text{for } \tau > 0. \end{cases}$$

We seek the solution of equation (1.28) satisfying the initial conditions

$$x(0) = 0, \quad x'(0) = 0.$$

Such the solution is called a unit step response. For an underdamped oscillator ($\delta < 1$) the solution has obviously the form

$$x = 1 + C e^{-\delta\tau} \cos(\nu\tau - \phi).$$

The initial conditions will be satisfied if

$$x(0) = 1 + C \cos \phi = 0,$$

and

$$x'(0) = -C(\delta \cos \phi - \nu \sin \phi) = 0. \quad (1.29)$$

It follows from the last equation and (1.20) that

$$\tan \phi = \frac{\delta}{\nu} = \frac{\delta}{\sqrt{1 - \delta^2}} \Rightarrow \phi = \nu \tau_* = \sqrt{1 - \delta^2} \tau_*,$$

where τ_* is given by (1.20). From $x(0) = 0$ we find the coefficient C

$$C = -\frac{1}{\cos \phi}.$$

Since $\tan \phi = \delta/\sqrt{1-\delta^2}$, it is easy to show that $\cos \phi = \sqrt{1-\delta^2}$, so

$$C = -\frac{1}{\sqrt{1-\delta^2}}.$$

Thus, the unit step response for the underdamped oscillator is given by

$$x_r(\tau) = 1 - \frac{e^{-\delta\tau}}{\sqrt{1-\delta^2}} \cos[\sqrt{1-\delta^2}(\tau - \tau_*)].$$

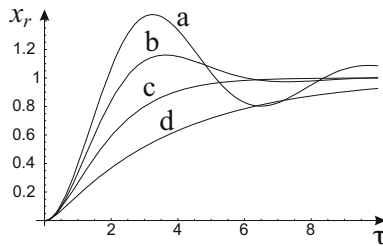

Fig. 1.17 Unit step response: a) $\delta = 0.25$, b) $\delta = 0.5$, c) $\delta = 1$, d) $\delta = 2$

Doing similar calculations, we can obtain the unit step responses also for the overdamped oscillator ($\delta > 1$)

$$x_r(\tau) = 1 - \frac{\delta + \kappa}{2\kappa} e^{-(\delta-\kappa)\tau} + \frac{\delta - \kappa}{2\kappa} e^{-(\delta+\kappa)\tau},$$

as well as for the critically damped oscillator ($\delta = 1$)

$$x_r(\tau) = 1 - (1 + \tau)e^{-\tau},$$

(see exercise 1.5). The graphs of these unit step responses are plotted in Fig. 1.17 for different values of damping ratio δ .

Particular Solution for General Excitations. Let us consider now an arbitrary excitation $g(\tau)$ which is zero for $\tau \leq 0$ and remains finite as τ goes to infinity. Since the initial conditions can later be satisfied by the solution of the corresponding homogeneous equation, we seek a particular solution of (1.28) satisfying the initial conditions

$$x(0) = 0, \quad x'(0) = 0.$$

The effective way of finding the solution is the Laplace transform (see, for example [13]). For any function $x(\tau)$ we define its Laplace transform according to

$$X(s) = \mathcal{L}[x(\tau)] = \int_0^{\infty} x(\tau)e^{-s\tau} d\tau,$$

with $X(s)$ being called the Laplace image of $x(\tau)$. We assume that the Laplace transforms of $g(\tau)$, $x(\tau)$ and its derivatives are defined for any complex number s with the positive real part. Applying the Laplace transform to both sides of equation (1.28), we obtain

$$\int_0^{\infty} (x'' + 2\delta x' + x)e^{-s\tau} d\tau = \int_0^{\infty} g(\tau)e^{-s\tau} d\tau.$$

Performing the partial integration, we have

$$\mathcal{L}[x'] = \int_0^{\infty} x'e^{-s\tau} d\tau = xe^{-s\tau}\Big|_0^{\infty} + \int_0^{\infty} sxe^{-s\tau} d\tau = s\mathcal{L}[x] = sX(s).$$

The initial condition $x(0) = 0$ as well as the behavior of $x(\tau)$ at infinity have been taken into account. Similarly,

$$\mathcal{L}[x''] = \int_0^{\infty} x''e^{-s\tau} d\tau = x'e^{-s\tau}\Big|_0^{\infty} + \int_0^{\infty} sx'e^{-s\tau} d\tau = s\mathcal{L}[x'] = s^2X(s).$$

Thus, the differential equation (1.28) is transformed into an algebraic equation

$$(s^2 + 2\delta s + 1)X(s) = G(s),$$

yielding immediately

$$X(s) = \frac{G(s)}{s^2 + 2\delta s + 1}. \quad (1.30)$$

To find the original function from its image function we apply the inverse Laplace transform to (1.30)

$$x(\tau) = \mathcal{L}^{-1}[X(s)] = \frac{1}{2\pi i} \int_{\alpha - i\infty}^{\alpha + i\infty} \frac{G(s)}{s^2 + 2\delta s + 1} e^{s\tau} ds, \quad (1.31)$$

where α is any real and positive number. Integral (1.31) is taken along the line $(\alpha - i\infty, \alpha + i\infty)$ in the complex plane of s . Since the roots of the characteristic equation have non-positive real parts, the integrand of (1.31) is regular along this line and thus, the integral converges. The problem reduces then to computing the inverse Laplace transform of the product $G(s)/(s^2 + 2\delta s + 1)$. Observe that the inverse Laplace transform of $sG(s)$ is $g'(\tau)$, while the inverse Laplace transform of $1/(s^2 + 2\delta s + 1)$ is the unit step response $x_r(\tau)$ found previously. Indeed, the Laplace transform of the Heaviside function is

$$\mathcal{L}[h(\tau)] = \int_0^{\infty} e^{-s\tau} d\tau = \frac{1}{s},$$

so, by substituting this in (1.30), we obtain $1/(s^2 + 2\delta s + 1)$ as the image function of the unit step response.

To compute the inverse Laplace transform of the product we use the following property of the Laplace transform. Consider two arbitrary functions $f(\tau)$ and $g(\tau)$, with $f(\tau) = g(\tau) = 0$ for $\tau \leq 0$. Denote the convolution of two functions $f(\tau)$ and $g(\tau)$ by

$$(f * g)(\tau) = \int_0^\infty f(\tau - t)g(t)dt = \int_0^\tau f(\tau - t)g(t)dt = (g * f)(\tau).$$

We compute the Laplace transform of the convolution

$$\mathcal{L}[f * g] = \int_0^\infty \left(\int_0^\infty f(\tau - t)g(t)dt \right) e^{-s\tau} d\tau.$$

Changing the order of integration with respect to τ and t , we have

$$\mathcal{L}[f * g] = \int_0^\infty \int_0^\infty f(\tau - t)e^{-s\tau} d\tau g(t) dt.$$

Changing the variable of integration from τ to $u = \tau - t$, we obtain finally

$$\mathcal{L}[f * g] = \int_0^\infty f(u)e^{-su} du \int_0^\infty g(t)e^{-st} dt = F(s)G(s).$$

Thus, the Laplace transform of the convolution $f * g$ is equal to the product $F(s)G(s)$ and vice versa. Consequently, the inverse Laplace transform of (1.31) yields

$$x(\tau) = \int_0^\tau g'(t)x_r(\tau - t)dt. \quad (1.32)$$

This is Duhamel's formula for the particular solution of (1.28).

Solution of Initial-Value Problem. It turns out that the Laplace transform can also be used to find the solution of the initial-value problem

$$\begin{aligned} x'' + 2\delta x' + x &= 0, \\ x(0) &= x_0, \quad x'(0) = x'_0. \end{aligned}$$

Indeed, applying the Laplace transform to this equation and observing that, due to the initial conditions,

$$\begin{aligned} \mathcal{L}[x'] &= \int_0^\infty x' e^{-s\tau} d\tau = -x_0 + sX(s), \\ \mathcal{L}[x''] &= \int_0^\infty x'' e^{-s\tau} d\tau = -x'_0 - sx_0 + s^2X(s), \end{aligned}$$

we obtain

$$(s^2 + 2\delta s + 1)X(s) = x'_0 + sx_0 + 2\delta x_0.$$

Thus,

$$X(s) = \frac{x'_0 + sx_0 + 2\delta x_0}{s^2 + 2\delta s + 1},$$

and the problem reduces to computing the inverse Laplace transform of the rational function (see exercise 1.6).

Energy Balance. We calculate the rate of change of the total energy due to the work done by the external force and the dissipation. Multiplying modified Langrange's equation (1.27) by \dot{x} , we obtain

$$\dot{x} \frac{d}{dt} \frac{\partial L}{\partial \dot{x}} - \dot{x} \frac{\partial L}{\partial x} = -\frac{\partial D}{\partial \dot{x}} \dot{x} + f(t)\dot{x}.$$

Making the same observation as in previous Section, we obtain the rate of change of energy in the form

$$\frac{d}{dt}(K + U) = -2D(\dot{x}) + f(t)\dot{x}. \quad (1.33)$$

Integrating equation (1.33) from t_0 to t , we find the energy change at time t

$$K + U - E_0 = -2 \int_{t_0}^t D(\dot{x}(s)) ds + \int_{t_0}^t f(s)\dot{x}(s) ds = -E_d(t) + W(t),$$

where E_0 is the total energy at $t = t_0$. The last term $W(t)$ is the work done by the external force which is stored in the energy of the system except that part $E_d(t)$ dissipated by the damper.

1.4 Harmonic Excitations and Resonance

As we know from Section 1.2, any solution of the homogeneous equation approaches zero as τ becomes large if the damping ratio δ is positive. Therefore only the particular solution of inhomogeneous equation which persists at large time (called forced vibration) presents interest in most applications. The forced vibration has been found in the previous Section for an arbitrary excitation through the Laplace transform leading to Duhamel's formula. In spite of this general method of solution we consider in this Section the special case of harmonic excitations for which the forced vibration can be determined directly and in a simple way, without using the Laplace transform technique. The results of this Section are also important for the variational-asymptotic method in non-linear vibrations.

Type of Excitations. We consider three cases of harmonic excitations.

Case a. Harmonic force excitation or excitation through the spring.

EXAMPLE 1.7. The damper-mass-spring oscillator is excited by the harmonic motion of the spring hanger: $x_e = x_0 \cos \omega t$ (see Fig. 1.18).

Since the spring force is proportional to the change of length $x - x_e(t)$, the equation of motion reads

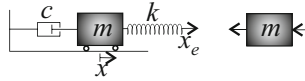

Fig. 1.18 Oscillator excited through spring hanger

$$m\ddot{x} = -c\dot{x} - k(x - x_e).$$

On the other side, the same equation can also be derived from the Lagrange function

$$L(x, \dot{x}) = \frac{1}{2}m\dot{x}^2 - \frac{1}{2}k(x_e(t) - x)^2$$

and the dissipation function $D(\dot{x}) = \frac{1}{2}c\dot{x}^2$. Bringing the two terms $-c\dot{x}$ and $-kx$ to the left-hand side and transforming the obtained equation to the dimensionless form as in Section 1.2, we get

$$x'' + 2\delta x' + x = x_0 \cos \eta \tau,$$

where $\eta = \omega/\omega_0$ is the frequency ratio. Note that the same equation of motion holds true for the forced oscillator in example 1.6 if we set $f(t) = f_0 \cos \omega t$ and $x_0 = f_0/k$.

Case b. Harmonic excitation through the damper.

EXAMPLE 1.8. The spring-mass-damper oscillator is excited by the harmonic motion of the damper piston: $x_e = x_0 \sin \omega t$ (see Fig. 1.19).

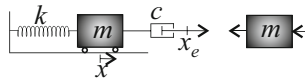

Fig. 1.19 Oscillator excited through damper piston

In this case the damping force as well as the dissipation function depend on the relative velocity $\dot{x} - \dot{x}_e$. Thus, the equation of motion takes the form

$$m\ddot{x} = -kx - c(\dot{x} - \dot{x}_e).$$

Bringing the two terms $-kx$ and $-c\dot{x}$ to the left-hand side and transforming the obtained equation to the dimensionless form, we get

$$x'' + 2\delta x' + x = 2\delta\eta x_0 \cos \eta \tau.$$

Case c. Harmonic excitation through the motion of the frame.

EXAMPLE 1.9. The spring-mass-damper oscillator is excited by the harmonic motion of the support frame: $x_e = x_0 \cos \omega t$ (see Fig. 1.20).

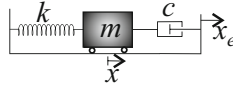

Fig. 1.20 Oscillator excited by motion of frame

We write the equation of motion in terms of the relative displacement of the mass with respect to the moving frame, $x_r = x - x_e$. Since the acceleration in the fixed inertial frame is $\ddot{x} = \ddot{x}_r + \ddot{x}_e$, we have

$$m(\ddot{x}_r + \ddot{x}_e) = -c\dot{x}_r - kx_r.$$

Bringing all terms in the right-hand side to the left-hand side, the term $m\ddot{x}_e = -m\omega^2 \cos \omega t$ to the right-hand side and transforming the obtained equation to the dimensionless form, we get

$$x_r'' + 2\delta x_r' + x_r = \eta^2 x_0 \cos \eta \tau.$$

One can of course derive the equations of motion in examples 1.8 and 1.9 also by the energy method (see exercise 1.8).

Thus, in all three cases we may present the equations of motion in the form

$$x'' + 2\delta x' + x = x_0 \alpha \cos \eta \tau, \quad (1.34)$$

where the factor α is equal to

$$\alpha = \begin{cases} 1 & \text{in case a,} \\ 2\delta\eta & \text{in case b,} \\ \eta^2 & \text{in case c.} \end{cases}$$

Amplitude and Phase of Forced Vibration. We seek the particular solution of equation (1.34) in form of harmonic motion

$$x = x_0 M \cos(\eta \tau - \psi) = x_0 M (\cos \eta \tau \cos \psi + \sin \eta \tau \sin \psi),$$

where M is called a magnification factor and ψ the phase of forced vibration. Differentiating this equation with respect to τ , we have

$$\begin{aligned} x' &= -x_0 M \eta (\sin \eta \tau \cos \psi - \cos \eta \tau \sin \psi), \\ x'' &= -x_0 M \eta^2 (\cos \eta \tau \cos \psi + \sin \eta \tau \sin \psi). \end{aligned}$$

Substitution of these formulas into the equation of motion (1.34) gives

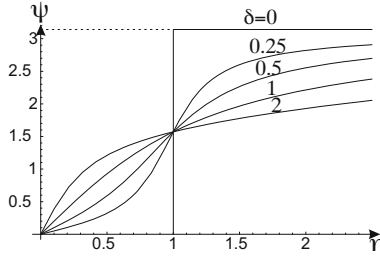

Fig. 1.21 Phase ψ versus frequency ratio η at different damping ratios δ

$$\begin{aligned} &\cos \eta \tau [x_0 M (1 - \eta^2) \cos \psi + 2\delta \eta x_0 M \sin \psi - x_0 \alpha] \\ &+ \sin \eta \tau [x_0 M (1 - \eta^2) \sin \psi - 2\delta \eta x_0 M \cos \psi] = 0. \end{aligned}$$

Since $\cos \eta \tau$ and $\sin \eta \tau$ are independent and are not identically zero, the expressions in the square brackets must vanish yielding

$$\tan \psi = \frac{2\delta \eta}{1 - \eta^2}, \tag{1.35}$$

and

$$M = \frac{\alpha}{(1 - \eta^2) \cos \psi + 2\delta \eta \sin \psi}.$$

We see from (1.35) that the phase ψ is independent of α , so it remains the same in all three cases. However, one should keep in mind that ψ in case b) is the phase difference between the response x and the velocity \dot{x}_e . The plot of $\psi(\eta)$ for different values of δ is shown in Fig. 1.21.

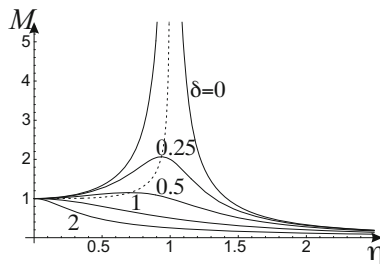

Fig. 1.22 Magnification factor M versus frequency ratio η at different damping ratios δ (case a)

The equation for the magnification factor M can still be reduced to the form independent of the phase ψ . We first note that, due to (1.35),

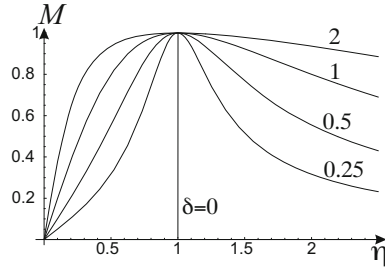

Fig. 1.23 Magnification factor M versus frequency ratio η at different damping ratios δ (case b)

$$(1 - \eta^2) \cos \psi + 2\delta\eta \sin \psi = 2\delta\eta \left(\sin \psi + \frac{\cos \psi}{\tan \psi} \right) = \frac{2\delta\eta}{\sin \psi}.$$

From the same formula (1.35) we can easily express $\sin \psi$ as

$$\sin \psi = \frac{2\delta\eta}{\sqrt{(1 - \eta^2)^2 + 4\delta^2\eta^2}}. \tag{1.36}$$

Thus,

$$M = \frac{\alpha}{\sqrt{(1 - \eta^2)^2 + 4\delta^2\eta^2}}. \tag{1.37}$$

The plots of magnification factor M versus the frequency ratio η for different values of damping ratio δ are shown in Figs. 1.22-1.24 in cases a, b, and c, respectively.

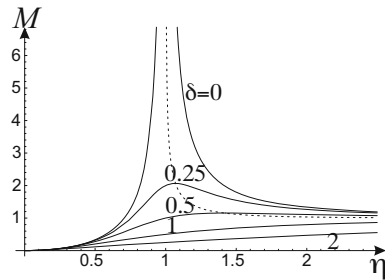

Fig. 1.24 Magnification factor M versus frequency ratio η at different damping ratios δ (case c)

One may be interested in finding the maximum of magnification factor and the frequency ratio at which this maximum is achieved. One speaks then of the resonant vibration. In case a) the maximum of M is achieved at $\eta_m = \sqrt{1 - 2\delta^2}$ giving

$$M_m = \frac{1}{\sqrt{1 - \eta_m^4}} = \frac{1}{2\delta\sqrt{1 - \delta^2}}$$

for $\delta < 1/\sqrt{2}$ and at $\eta = 0$ giving $M_m = 1$ otherwise. In case b) the maximum is always achieved at $\eta = 1$ giving $M_m = 1$. In case c) the maximum of M is achieved at $\eta_m = 1/\sqrt{1 - 2\delta^2}$ giving

$$M_m = \frac{\eta_m^2}{\sqrt{\eta_m^4 - 1}} = \frac{1}{2\delta\sqrt{1 - \delta^2}}$$

for $\delta < 1/\sqrt{2}$ and at $\eta = \infty$ giving $M_m = 1$ otherwise. The curves corresponding to the maxima of the magnification factors are drawn in Figs. 1.22 and 1.24 by the dashed lines. It is remarkable that the maxima of M are in general not achieved when the frequency of external excitation coincides with the frequency of free vibration $\omega_c = \omega_0\sqrt{1 - \delta^2}$ (which means $\eta = \sqrt{1 - \delta^2}$) except the case $\delta = 0$ for which $M_m = \infty$ (strict resonance).³ Some characteristic values of phase and magnification factors are presented in Table 1.1.

Table 1.1 Characteristic values of ψ and M

η	ψ	M (case a)	M (case b)	M (case c)
0	0	1	0	0
1	$\pi/2$	$\frac{1}{2\delta}$	1	$\frac{1}{2\delta}$
∞	π	0	0	1
η_m	-	$\frac{1}{2\delta\sqrt{1 - \delta^2}}$	1	$\frac{1}{2\delta\sqrt{1 - \delta^2}}$

Power and Work. Let us find out the power and work done by the external force on the forced vibration. We define the power of the external force as

$$P = f(t)\dot{x}.$$

For the forced oscillator with $f(t) = kx_0 \cos \omega t$ (case a) the forced vibration is described by

$$x = x_0 M \cos(\omega t - \psi), \quad \dot{x} = -x_0 \omega M \sin(\omega t - \psi).$$

³ Actually the solution in this case is $x_0 M \tau \sin \tau$, and its amplitude tends to infinity only in the limit $\tau \rightarrow \infty$ (see exercise 1.10).

Thus,

$$\begin{aligned} P &= f(t)\dot{x} = -kx_0^2\omega M \cos \omega t \sin(\omega t - \psi) \\ &= \frac{1}{2}kx_0^2\omega M [\sin \psi - \sin(2\omega t - \psi)] = P_a - P_i, \end{aligned}$$

where the constant part $P_a = \frac{1}{2}kx_0^2\omega M \sin \psi$ is called an active power, while the oscillating with doubled frequency part $P_i = \frac{1}{2}kx_0^2\omega M \sin(2\omega t - \psi)$ an idle power. Remembering the formulas (1.36) and (1.37), we obtain in case a)

$$\begin{aligned} P_a &= kx_0^2\omega_0 \frac{\delta\eta^2}{(1-\eta^2)^2 + 4\delta^2\eta^2} = kx_0^2\omega_0 M_a, \\ P_i &= kx_0^2\omega_0 \frac{\eta}{2\sqrt{(1-\eta^2)^2 + 4\delta^2\eta^2}} \sin(2\omega t - \psi) = kx_0^2\omega_0 M_i \sin(2\omega t - \psi). \end{aligned}$$

Knowing the power, we can easily calculate the work done by the external force according to

$$W = \int_{t_0}^t P dt = \frac{1}{2}F_0\hat{x}\omega(t-t_0) \sin \psi + \frac{1}{4}F_0\hat{x}[\cos(2\omega t - \psi) - \cos(2\omega t_0 - \psi)],$$

where $F_0 = kx_0$ and $\hat{x} = x_0M$. We see that the work done by the external force can be decomposed into two parts: the active work W_a which grows linearly with time, and the idle work W_i which is the periodic function. The work done in one period of vibration is given by

$$W^* = \pi F_0\hat{x} \sin \psi.$$

We know that, for periodic motions, the kinetic and potential energies are periodic functions, so they do not change in one period. In contrary, the energy dissipation in one period of vibration is positive and equals

$$R^* = 2 \int_0^T D(\dot{x}) dt = c\omega\hat{x}^2 \int_0^{2\pi} \sin^2(\omega t - \psi) d(\omega t) = \pi c\hat{x}^2\omega.$$

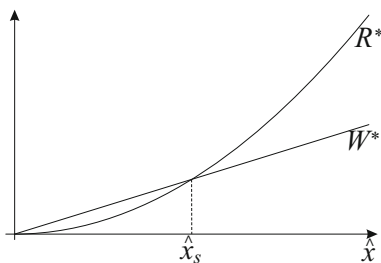

Fig. 1.25 Energy diagram of forced vibration

Diagram 1.25 shows the comparison between the work done W^* and the energy dissipation R^* in one period of forced vibration as function of the amplitude \hat{x} at some fixed frequency. While the work done in one period is a linear function of \hat{x} , the energy dissipation is quadratic with respect to \hat{x} . The straight line cuts the parabola at a point with coordinate $\hat{x}_s = F_0 \sin \psi / c\omega$. If $\hat{x} < \hat{x}_s$, then the work done by the external force is larger than the energy dissipation, so the amplitude of forced vibration must increase. If $\hat{x} > \hat{x}_s$, then the work done by the external force is smaller than the energy dissipation, so the amplitude decreases. Thus, \hat{x}_s corresponds to the steady-state amplitude of forced vibration.

1.5 Exercises

EXERCISE 1.1. Derive the equation of motion of a roller (mass m , radius r) hung on an unstretchable rope and a spring (see Fig. 1.26) with the help of

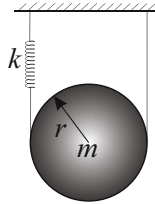

Fig. 1.26 Roller hung on rope and spring

- i) the force method,
- ii) the energy method.

Determine the eigenfrequency of vibration.

Solution. i) The force method. We free the roller from the rope and the spring (see Fig. 1.27) and apply the moment equation about A

$$\frac{d}{dt}(J_A \dot{\varphi}) = \sum M_z = -F_s 2r.$$

From the kinematics we know that $\varphi = x/2r$. Besides, the spring force is equal to $F_s = kx$, while the moment of inertia of the roller about A is

$$J_A = J_O + mr^2 = \frac{1}{2}mr^2 + mr^2 = \frac{3}{2}mr^2.$$

Thus, the equation of motion reads

$$\frac{3}{2}mr^2 \frac{\ddot{x}}{2r} = -kx2r \quad \Rightarrow \quad \ddot{x} + \frac{8k}{3m}x = 0,$$

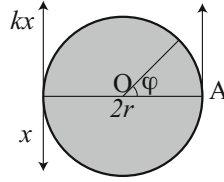

Fig. 1.27 Roller and the forces

and the eigenfrequency is given by

$$\omega_0^2 = \frac{8k}{3m} \Rightarrow \omega_0 = \sqrt{\frac{8k}{3m}}.$$

ii) The energy method. We write down the kinetic and potential energies:

$$K = \frac{1}{2}J_A\dot{\phi}^2, \quad U = \frac{1}{2}kx^2.$$

Taking into account the kinematic relation $\phi = x/2r$ and the formula $J_A = \frac{3}{2}mr^2$, we obtain the Lagrange function in the form

$$L = K - U = \frac{3}{16}m\dot{x}^2 - \frac{1}{2}kx^2.$$

Then, from Lagrange's equation

$$\frac{d}{dt} \frac{\partial L}{\partial \dot{x}} - \frac{\partial L}{\partial x} = 0,$$

we derive again the above equation of motion and the formula for ω_0 .

EXERCISE 1.2. Derive the equation of motion of a thin circular ring (mass m , radius r) hung on a support O (see Fig. 1.28). Determine the eigenfrequency of its small vibration.

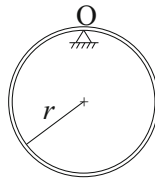

Fig. 1.28 Ring hung on support

Solution. We write down the kinetic and potential energies:

$$K = \frac{1}{2}J_O\dot{\varphi}^2, \quad U = mgr(1 - \cos\varphi).$$

The moment of inertia of the thin ring is equal to

$$J_O = J_S + mr^2 = mr^2 + mr^2 = 2mr^2.$$

For small vibrations with $\varphi \ll 1$ we approximate $1 - \cos\varphi \approx \frac{1}{2}\varphi^2$. Thus,

$$L = mr^2\dot{\varphi}^2 - \frac{1}{2}mgr\varphi^2.$$

From Lagrange's equation we derive the equation of motion

$$2mr^2\ddot{\varphi} + mgr\varphi = 0.$$

Consequently, the eigenfrequency is

$$\omega_0 = \sqrt{\frac{g}{2r}}.$$

EXERCISE 1.3. Three turning points are measured from the vibration of a damped oscillator: $x_1 = 8.6\text{mm}$, $x_2 = -4.1\text{mm}$, $x_3 = 4.3\text{mm}$. Determine the middle point of vibration (position of equilibrium). Find the logarithmic decrement ϑ and the damping ratio δ .

Solution. The free vibration of the underdamped oscillator is described by

$$x(\tau) = x_m + a_0e^{-\delta\tau}\cos(\nu\tau - \phi),$$

where x_m corresponds to the position of equilibrium. As we know, $x(\tau)$ achieves maxima or minima if

$$\tan(\nu\tau - \phi) = -\delta/\nu.$$

So, the turning points (corresponding to maxima or minima) occur at the time instants τ_1 , $\tau_1 + \tau_c/2$, $\tau_1 + \tau_c$ and so on, with τ_1 being the time instant of the first turning point and $\tau_c = 2\pi/\nu$ the conditional period of vibration. Taking the periodicity of cosine function into account, we have

$$\begin{aligned} x_1 &= x_m + C, \\ x_2 &= x_m - Ce^{-\delta\pi/\nu}, \\ x_3 &= x_m + Ce^{-\delta 2\pi/\nu}, \end{aligned}$$

where $C = a_0e^{-\delta\tau_1}\cos(\nu\tau_1 - \phi)$. Forming the differences we easily see that

$$\frac{x_1 - x_2}{x_3 - x_2} = e^{\delta\pi/\nu} = e^{\delta\tau_c/2}.$$

Thus,

$$\ln \frac{x_1 - x_2}{x_3 - x_2} = \delta \tau_c / 2 = \frac{\vartheta}{2},$$

with ϑ being the logarithmic decrement. Substituting the given values of turning points into this formula we obtain

$$\vartheta = 2 \ln \frac{x_1 - x_2}{x_3 - x_2} = 0.827.$$

Knowing the logarithmic decrement, we find Lehr's damping ratio

$$\delta = \frac{\vartheta}{\sqrt{4\pi^2 + \vartheta^2}} = 0.13.$$

Now we form the differences $x_1 - x_m$ and $x_m - x_2$ and consider the quotient

$$\frac{x_1 - x_m}{x_m - x_2} = e^{\delta \tau_c / 2} = e^{\vartheta / 2}.$$

From the last equation it is ready to find x_m

$$x_m = \frac{x_1 + x_2 e^{\vartheta / 2}}{1 + e^{\vartheta / 2}} = 0.956 \text{ mm}.$$

EXERCISE 1.4. The time constants are measured from the vibration of a damped oscillator: $T_d = 5\text{s}$, $T_c = 2\text{s}$. Determine ϑ and δ .

Solution. According to the formulas for the characteristic times T_d and T_c we have

$$T_d = \frac{1}{\delta \omega_0} \quad \text{and} \quad T_c = \frac{2\pi}{\omega_0 \sqrt{1 - \delta^2}}.$$

Thus, it is not difficult to see that

$$\vartheta = \frac{2\pi\delta}{\sqrt{1 - \delta^2}} = \frac{T_c}{T_d} = 0.4.$$

Knowing ϑ , we can restore the damping ratio δ according to

$$\delta = \frac{\vartheta}{\sqrt{4\pi^2 + \vartheta^2}} = 0.0635.$$

EXERCISE 1.5. Determine the unit step responses for the overdamped and the critically damped oscillators.

Solution. For an overdamped oscillator ($\delta > 1$) the unit step response satisfying the initial conditions

$$x_r(0) = 0, \quad x'_r(0) = 0$$

has obviously the form

$$x_r(\tau) = 1 + Ae^{-q_1\tau} + Be^{-q_2\tau},$$

where

$$q_1 = \delta - \kappa, \quad q_2 = \delta + \kappa,$$

and $\kappa = \sqrt{\delta^2 - 1}$. Substituting this solution into the initial conditions, we obtain for A and B the equations

$$\begin{aligned} x_r(0) &= 1 + A + B = 0, \\ x'_r(0) &= -Aq_1 - Bq_2 = 0. \end{aligned}$$

Solving these equations with respect to A and B , we get

$$A = -\frac{\delta + \kappa}{2\kappa}, \quad B = \frac{\delta - \kappa}{2\kappa}.$$

Thus,

$$x_r(\tau) = 1 - \frac{\delta + \kappa}{2\kappa}e^{-(\delta - \kappa)\tau} + \frac{\delta - \kappa}{2\kappa}e^{-(\delta + \kappa)\tau}.$$

For a critically damped oscillator ($\delta = 1$) the unit step response must have the form

$$x_r(\tau) = 1 + e^{-\tau}(A\tau + B).$$

The initial conditions lead to

$$x_r(0) = 1 + B = 0, \quad x'_r(0) = A - B = 0,$$

yielding

$$A = B = -1.$$

Thus,

$$x_r(\tau) = 1 - (1 + \tau)e^{-\tau}.$$

EXERCISE 1.6. Find the solution of the initial-value problem

$$x'' + 2\delta x' + x = 0,$$

satisfying $x(0) = x_0$ and $x'(0) = x'_0$ with the help of the Laplace transform.

Solution. As shown in Section 1.3 the Laplace transform applied to this initial-value problem leads to

$$X(s) = \frac{x'_0 + sx_0 + 2\delta x_0}{s^2 + 2\delta s + 1},$$

where $X(s)$ is the Laplace image of $x(\tau)$. Thus, the problem reduces to computing the inverse Laplace transform of the rational function

$$x(\tau) = \mathcal{L}^{-1}[X(s)] = \frac{1}{2\pi i} \int_{\alpha - i\infty}^{\alpha + i\infty} \frac{x'_0 + sx_0 + 2\delta x_0}{s^2 + 2\delta s + 1} e^{s\tau} ds.$$

Since $X(s)$ is the ratio of two polynomials $P(s)/Q(s)$, its inverse Laplace transform equals the sum of the residues of $X(s)e^{s\tau}$ at the singular points (poles) of $X(s)$. For the overdamped oscillator ($\delta > 1$) we have two different real roots of the characteristic equation corresponding to two simple poles of $X(s)$

$$s = s_1 = -q_1, \quad s = s_2 = -q_2,$$

therefore

$$x(\tau) = \frac{P(-q_1)}{Q'(-q_1)} e^{-q_1\tau} + \frac{P(-q_2)}{Q'(-q_2)} e^{-q_2\tau}.$$

Since

$$P(s) = x'_0 + sx_0 + 2\delta x_0, \quad Q'(s) = 2s + 2\delta,$$

and

$$q_1 = \delta - \kappa, \quad q_2 = \delta + \kappa,$$

we easily find that

$$\frac{P(-q_1)}{Q'(-q_1)} = \frac{1}{2\kappa}(x'_0 + q_2x_0), \quad \frac{P(-q_2)}{Q'(-q_2)} = -\frac{1}{2\kappa}(x'_0 + q_1x_0).$$

Thus,

$$x(\tau) = \frac{1}{2\kappa}[(x'_0 + q_2x_0)e^{-q_1\tau} - (x'_0 + q_1x_0)e^{-q_2\tau}],$$

which agrees with the formula (1.19).

For the underdamped oscillator with $\delta < 1$ we have two complex conjugate roots, and the computation of the inverse Laplace transform can be done in a similar manner. For the critically damped oscillator ($\delta = 1$) there is one double root $s = -1$ corresponding to the pole of order two, so

$$x(\tau) = \frac{d}{ds}[P(s)e^{s\tau}] \Big|_{s=-1} = e^{-\tau}[x_0(1 + \tau) + x'_0\tau].$$

EXERCISE 1.7. Use Duhamel's formula to compute the response of the critically damped oscillator with $\delta = 1$ to the so-called ramp function

$$g(\tau) = \begin{cases} 0 & \text{for } \tau < 0, \\ \alpha\tau & \text{for } 0 \leq \tau \leq \tau_0, \\ \alpha\tau_0 & \text{for } \tau > \tau_0. \end{cases}$$

The oscillator was at rest for $\tau \leq 0$.

Solution. According to Duhamel's formula

$$x(\tau) = \int_0^\tau g'(t)x_r(\tau - t) dt,$$

where $x_r(\tau)$ is the unit step response function. For $\delta = 1$ we have

$$x_r(\tau) = 1 - (1 + \tau)e^{-\tau}.$$

We compute the derivative of the ramp function $g(\tau)$ given above

$$g'(\tau) = \begin{cases} 0 & \text{for } \tau < 0, \\ \alpha & \text{for } 0 \leq \tau \leq \tau_0, \\ 0 & \text{for } \tau > \tau_0. \end{cases}$$

So we need to consider two different cases.

Case a: $\tau \leq \tau_0$. In this case

$$\begin{aligned} x(\tau) &= \int_0^\tau \alpha [1 - (1 + (\tau - t))e^{-(\tau - t)}] dt \\ &= \alpha \left[\tau - \int_0^\tau e^{-(\tau - t)} dt - \int_0^\tau (\tau - t)e^{-(\tau - t)} dt \right] \\ &= \alpha \left[\tau - \int_{-\tau}^0 e^u du + \int_{-\tau}^0 ue^u du \right] \\ &= \alpha(\tau - 2 + 2e^{-\tau} + \tau e^{-\tau}) = \alpha[\tau - 2 + (\tau + 2)e^{-\tau}]. \end{aligned}$$

Case b: $\tau > \tau_0$. Since $g'(\tau) = 0$ for $\tau > \tau_0$, we have

$$\begin{aligned} x(\tau) &= \int_0^{\tau_0} \alpha [1 - (1 + (\tau - t))e^{-(\tau - t)}] dt \\ &= \alpha \left[\tau_0 - \int_0^{\tau_0} e^{-(\tau - t)} dt - \int_0^{\tau_0} (\tau - t)e^{-(\tau - t)} dt \right] \\ &= \alpha \left[\tau_0 - \int_{-\tau}^{\tau_0 - \tau} e^u du + \int_{-\tau}^{\tau_0 - \tau} ue^u du \right] \\ &= \alpha[\tau_0 - (2 + \tau - \tau_0)e^{-(\tau - \tau_0)} + (\tau + 2)e^{-\tau}]. \end{aligned}$$

EXERCISE 1.8. Derive the equations of motion in examples 1.8 and 1.9 by the energy method.

Solution. In example 1.8 (see Fig. 1.19) the Lagrange function reads

$$L(x, \dot{x}) = \frac{1}{2}m\dot{x}^2 - \frac{1}{2}kx^2.$$

The dissipation function depends however on the relative velocity

$$D = \frac{1}{2}c(\dot{x} - \dot{x}_e)^2.$$

From modified Lagrange's equation for dissipative systems

$$\frac{d}{dt} \frac{\partial L}{\partial \dot{x}} - \frac{\partial L}{\partial x} + \frac{\partial D}{\partial \dot{x}} = 0,$$

we derive the equation of motion

$$m\ddot{x} + kx + c(\dot{x} - \dot{x}_e) = 0.$$

For the system in example 1.9 (see Fig. 1.20) the Lagrange function reads

$$L(x, \dot{x}) = \frac{1}{2}m\dot{x}^2 - \frac{1}{2}k(x - x_e)^2.$$

We see that the potential energy depends on the relative displacement. The dissipation function depends also on the relative velocity

$$D = \frac{1}{2}c(\dot{x} - \dot{x}_e)^2.$$

From modified Lagrange's equation for dissipative systems

$$\frac{d}{dt} \frac{\partial L}{\partial \dot{x}} - \frac{\partial L}{\partial x} + \frac{\partial D}{\partial \dot{x}} = 0,$$

we derive the equation of motion

$$m\ddot{x} + k(x - x_e) + c(\dot{x} - \dot{x}_e) = 0.$$

Introducing the relative displacement $x_r = x - x_e$, we can present this equation in the form

$$m\ddot{x}_r + c\dot{x}_r + kx_r = -m\ddot{x}_e.$$

EXERCISE 1.9. Derive the equation of vertical motion of a frame (mass m_f) excited by two rotating unbalanced masses (mass $m_u/2$, frequency of rotation ω , radius of rotation r). The frame is connected with two springs of equal stiffness $k/2$ and a damper with damping constant c (see Fig. 1.29). Determine the magnification factor of forced vibration.

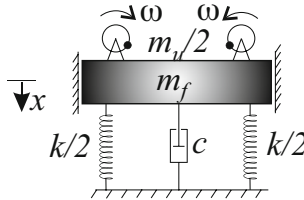

Fig. 1.29 Vertical forced vibration of frame

Solution. We derive the equation of motion by the energy method. Let x be the vertical displacement of the center of mass of the frame from the equilibrium position. The displacements of the unbalanced masses from their equilibrium positions are given by

$$x_u = x + r \cos \omega t, \quad y_u = \pm r \sin \omega t.$$

The plus and minus signs are due to the fact that the unbalanced masses rotate in the opposite directions. Their velocities are

$$\dot{x}_u = \dot{x} - r\omega \sin \omega t, \quad \dot{y}_u = \pm r\omega \cos \omega t.$$

Thus, the kinetic energy of masses equals

$$K(\dot{x}) = \frac{1}{2}m_f\dot{x}^2 + \frac{1}{2}m_u(\dot{x} - r\omega \sin \omega t)^2 + \frac{1}{2}m_u r^2 \omega^2 \cos^2 \omega t.$$

Since the gravitational force and the static spring forces do not contribute to the potential energy, we have

$$U(x) = \frac{1}{2}kx^2.$$

The Lagrange function reads

$$L = K - U = \frac{1}{2}m_f\dot{x}^2 + \frac{1}{2}m_u(\dot{x} - r\omega \sin \omega t)^2 + \frac{1}{2}m_u r^2 \omega^2 \cos^2 \omega t - \frac{1}{2}kx^2.$$

The dissipation function is given by

$$D(\dot{x}) = \frac{1}{2}c\dot{x}^2.$$

From modified Lagrange's equation

$$\frac{d}{dt} \frac{\partial L}{\partial \dot{x}} - \frac{\partial L}{\partial x} + \frac{\partial D}{\partial \dot{x}} = 0,$$

we derive the equation of motion of this system

$$(m_f + m_u)\ddot{x} + c\dot{x} + kx = m_u r \omega^2 \cos \omega t.$$

The eigenfrequency of free and undamped vibration is $\omega_0 = \sqrt{\frac{k}{m_f + m_u}}$. Introducing the dimensionless time $\tau = \omega_0 t$, we reduce the equation of motion to the standard form

$$x'' + 2\delta x' + x = x_0 \eta^2 \cos \eta \tau,$$

where

$$\delta = \frac{c\omega_0}{2k}, \quad x_0 = \frac{m_u}{m_f + m_u} r, \quad \eta = \frac{\omega}{\omega_0}.$$

The forced vibration reads

$$x = x_0 M \cos(\eta \tau - \psi) = x_0 M (\cos \eta \tau \cos \psi + \sin \eta \tau \sin \psi),$$

where M is called a magnification factor and ψ the phase of forced vibration. The magnification factor is equal to (see Section 1.4)

$$M = \frac{\eta^2}{\sqrt{(1 - \eta^2)^2 + 4\delta^2\eta^2}}.$$

EXERCISE 1.10. Show that the variational problem

$$\delta \int_0^{2\pi} \left(\frac{1}{2}x'^2 - \frac{1}{2}x^2 + \cos \tau x \right) d\tau = 0$$

has no extremal in the class of periodic functions with $x(0) = x(2\pi)$ and $x'(0) = x'(2\pi)$. Find its extremal. What happens if the last term in the integrand is $\sin \tau x$?

Solution. Lagrange's equation for the extremal of this action functional reads

$$x'' + x = \cos \tau.$$

Since the frequency of the external excitation coincides with the eigenfrequency of the system corresponding to the resonance, we look for the particular solution of this equation in the form

$$x(\tau) = A\tau \sin \tau.$$

Computing the derivatives of $x(\tau)$, we have

$$x' = A(\sin \tau + \tau \cos \tau), \quad x'' = A(2 \cos \tau - \tau \sin \tau).$$

Substituting these formulas into Lagrange's equation, we find that

$$x'' + x = 2A \cos \tau = \cos \tau \quad \Rightarrow \quad A = \frac{1}{2}.$$

The general solution then follows

$$x(\tau) = \frac{1}{2}\tau \sin \tau + a \cos(\tau - \phi).$$

We see that the extremal is non-periodic, and the amplitude of forced vibration goes to infinity as $\tau \rightarrow \infty$.

If the last term in the action functional is replaced by $\sin \tau x$, then the Lagrange's equation changes to

$$x'' + x = \sin \tau.$$

Similar calculations show that

$$x(\tau) = -\frac{1}{2}\tau \cos \tau + a \cos(\tau - \phi).$$

This corresponds again to the resonance because the extremal is non-periodic, and the amplitude of forced vibration goes to infinity as $\tau \rightarrow \infty$.

EXERCISE 1.11. Find the maxima of the magnification factors M in three cases a, b, and c considered in Section 1.4.

Solution. As shown in Section 1.4, the magnification factor M is given by

$$M = \frac{\alpha}{\sqrt{(1 - \eta^2)^2 + 4\delta^2\eta^2}},$$

where

$$\alpha = \begin{cases} 1 & \text{in case a,} \\ 2\delta\eta & \text{in case b,} \\ \eta^2 & \text{in case c.} \end{cases}$$

To find the maximum of M we must differentiate M with respect to η . Consider first case a. In this case

$$\frac{dM_a}{d\eta} = \frac{2\eta(1 - \eta^2 - 2\delta^2)}{[(1 - \eta^2)^2 + 4\delta^2\eta^2]^{3/2}}.$$

Equating this derivative with zero, we find that the maximum is achieved either at $\eta = 0$ or at

$$\eta = \sqrt{1 - 2\delta^2}.$$

Substituting these values into the formula for M , we find that the maximum is either 1 or

$$\max M_a = \frac{1}{2\delta\sqrt{1 - \delta^2}}.$$

In case b we have

$$\frac{dM_b}{d\eta} = \frac{2\delta}{\sqrt{(1 - \eta^2)^2 + 4\delta^2\eta^2}} - \frac{\delta\eta(-4(1 - \eta^2)\eta + 8\delta^2\eta)}{[(1 - \eta^2)^2 + 4\delta^2\eta^2]^{3/2}}.$$

Simplifying this expression, we obtain

$$\frac{dM_b}{d\eta} = \frac{2\delta(1 - \eta^2)(1 + \eta^2)}{[(1 - \eta^2)^2 + 4\delta^2\eta^2]^{3/2}}.$$

Thus, the maximum is always achieved at $\eta = 1$ giving $\max M_b = 1$.

In case c the calculations give

$$\frac{dM_c}{d\eta} = \frac{2\eta}{\sqrt{(1 - \eta^2)^2 + 4\delta^2\eta^2}} - \frac{\eta^2(-2(1 - \eta^2)\eta + 4\delta^2\eta)}{[(1 - \eta^2)^2 + 4\delta^2\eta^2]^{3/2}}.$$

Simplifying this expression, we obtain

$$\frac{dM_c}{d\eta} = \frac{2\eta(1 - (1 - 2\delta^2)\eta^2)}{[(1 - \eta^2)^2 + 4\delta^2\eta^2]^{3/2}}.$$

Thus, the maximum of M_c is achieved at $\eta_m = 1/\sqrt{1 - 2\delta^2}$ giving

$$\max M_c = \frac{\eta_m^2}{\sqrt{\eta_m^4 - 1}} = \frac{1}{2\delta\sqrt{1 - \delta^2}}$$

for $\delta < 1/\sqrt{2}$, and at $\eta = \infty$ giving $\lim_{\eta \rightarrow \infty} M_c = 1$ otherwise.

EXERCISE 1.12. Find the idle and active works done by the external forces in cases b and c considered in Section 1.4.

Solution. In example 1.8 corresponding to case b (see Fig. 1.19) the equation of motion reads

$$m\ddot{x} + kx + c\dot{x} = c\dot{x}_e = c\omega x_0 \cos \omega t.$$

The right-hand side of this equation is the force acting on the damper piston. The power of this force is equal to

$$\begin{aligned} P &= f(t)\dot{x} = -cx_0^2\omega^2 M \cos \omega t \sin(\omega t - \psi) \\ &= \frac{1}{2}cx_0^2\omega^2 M [\sin \psi - \sin(2\omega t - \psi)] = P_a - P_i. \end{aligned}$$

The constant part $P_a = \frac{1}{2}cx_0^2\omega^2 M \sin \psi$ is the active power while the oscillating with doubled frequency part $P_i = \frac{1}{2}cx_0^2\omega^2 M \sin(2\omega t - \psi)$ an idle power. Remembering the formulas for M and $\sin \psi$, we have in case b

$$\begin{aligned} P_a &= cx_0^2\omega_0^2 \frac{2\delta^2\eta^4}{(1-\eta^2)^2 + 4\delta^2\eta^2}, \\ P_i &= cx_0^2\omega_0^2 \frac{\delta\eta^3}{\sqrt{(1-\eta^2)^2 + 4\delta^2\eta^2}} \sin(2\omega t - \psi). \end{aligned}$$

In example 1.9 corresponding to case c (see Fig. 1.20) the equation of motion reads

$$m\ddot{x}_r + kx_r + c\dot{x}_r = -m\ddot{x}_e = m\omega^2 x_0 \cos \omega t.$$

The right-hand side of this equation is the force acting on the frame. The power of this force is equal to

$$\begin{aligned} P &= f(t)\dot{x}_e = -mx_0^2\omega^3 M \cos \omega t \sin(\omega t - \psi) \\ &= \frac{1}{2}mx_0^2\omega^3 M [\sin \psi - \sin(2\omega t - \psi)] = P_a - P_i. \end{aligned}$$

The constant part $P_a = \frac{1}{2}mx_0^2\omega^3 M \sin \psi$ is the active power while the oscillating with doubled frequency part $P_i = \frac{1}{2}mx_0^2\omega^3 M \sin(2\omega t - \psi)$ an idle power. Recalling the formulas for M and $\sin \psi$, we have in case c

$$\begin{aligned} P_a &= mx_0^2\omega_0^3 \frac{\delta\eta^6}{(1-\eta^2)^2 + 4\delta^2\eta^2}, \\ P_i &= \frac{1}{2}mx_0^2\omega_0^3 \frac{\eta^5}{\sqrt{(1-\eta^2)^2 + 4\delta^2\eta^2}} \sin(2\omega t - \psi). \end{aligned}$$

Integrating these formulas over t , we easily find the active and idle works.

Chapter 2

Coupled Oscillators

This chapter deals with small vibrations of mechanical systems with many degrees of freedom. The effective method of solution for conservative systems is the linear transformation leading to uncoupled single oscillators. For dissipative systems the effective method of solution is the Laplace transform based on the linear superposition principle.

2.1 Conservative Oscillators

Differential Equations of Motion. Just as for systems with one degree of freedom, we can use either the force method or the energy method to derive the equations of motion for systems with two or several degrees of freedom. In the force method we must free each part of the system from the surrounding, then draw the free-body diagram with all acting forces, and finally apply Newton's law. In the energy method based on Hamilton's variational principle, we find the Lagrange function in terms of generalized coordinates and velocities and write down Lagrange's equations. We will see that, although both methods are equivalent, the energy method turns out to be more succinct for systems with many degrees of freedom and with various constraints. Let us begin with conservative systems having two degrees of freedom.

EXAMPLE 2.1. Coupled mass-spring oscillators. Two point-masses m_1 and m_2 move horizontally under the action of two massless springs of stiffnesses k_1 and k_2 (see Fig. 2.1). Derive the equations of motion for these coupled oscillators.

Let x_1 and x_2 be the displacements from the equilibrium positions of the point-masses m_1 and m_2 , respectively. In the force method we first free the point-mass m_1 from the springs, then draw the free-body diagram (see Fig. 2.1), and finally apply Newton's law for m_1 in the x -direction

$$m_1 \ddot{x}_1 = \sum F_x = -k_1 x_1 + k_2 (x_2 - x_1).$$

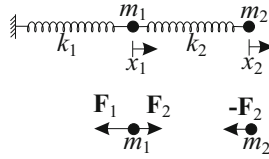

Fig. 2.1 Coupled mass-spring oscillators

Repeating the same procedure for m_2 (see Fig. 2.1), we obtain

$$m_2 \ddot{x}_2 = \sum F_x = -k_2(x_2 - x_1).$$

Bringing the spring forces to the left-hand sides, we arrive at the system of equations of motion

$$\begin{aligned} m_1 \ddot{x}_1 + k_1 x_1 - k_2(x_2 - x_1) &= 0, \\ m_2 \ddot{x}_2 + k_2(x_2 - x_1) &= 0. \end{aligned} \tag{2.1}$$

To use the energy method we write down the kinetic energy

$$K(\dot{x}) = \frac{1}{2} m_1 \dot{x}_1^2 + \frac{1}{2} m_2 \dot{x}_2^2,$$

and the potential energy

$$U(x) = \frac{1}{2} k_1 x_1^2 + \frac{1}{2} k_2 (x_2 - x_1)^2,$$

where $x = (x_1, x_2)$, $\dot{x} = (\dot{x}_1, \dot{x}_2)$. With the Lagrange function $L(x, \dot{x}) = K(\dot{x}) - U(x)$, we derive from Lagrange's equations (see the derivation of these equations from Hamilton's variational principle in Section 2.4)

$$\frac{d}{dt} \frac{\partial L}{\partial \dot{x}_j} - \frac{\partial L}{\partial x_j} = 0, \quad j = 1, 2$$

the equations of motion (2.1).

EXAMPLE 2.2. Coupled pendulums. Two pendulums are connected with each other by a spring of stiffness k (see Fig. 2.2). Derive the equations of motion for this system.

In the force method we must free the first pendulum and add the spring force to the free-body diagram drawn for the mathematical pendulum in example 1.2. Because of the smallness of φ_1 and φ_2 , the magnitude of the spring force is equal to $kl(\varphi_2 - \varphi_1)/2$, so the moment equation about A reads

$$m_1 l^2 \ddot{\varphi}_1 = \sum M_z = -m_1 g l \varphi_1 + k \frac{l^2}{4} (\varphi_2 - \varphi_1).$$

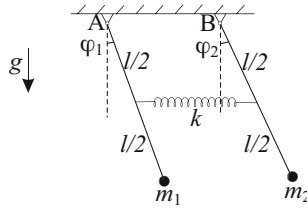

Fig. 2.2 Coupled pendulums

Applying the same procedure to the second pendulum, we obtain

$$m_2 l^2 \ddot{\varphi}_2 = \sum M_z = -m_2 g l \varphi_2 - k \frac{l^2}{4} (\varphi_2 - \varphi_1).$$

To use the energy method we write down the kinetic energy

$$K(\dot{\varphi}) = \frac{1}{2} m_1 l^2 \dot{\varphi}_1^2 + \frac{1}{2} m_2 l^2 \dot{\varphi}_2^2,$$

and, taking into account the smallness of φ_1 and φ_2 , the potential energy

$$U(\varphi) = \frac{1}{2} m_1 g l \varphi_1^2 + \frac{1}{2} m_2 g l \varphi_2^2 + \frac{1}{2} k (l(\varphi_2 - \varphi_1)/2)^2,$$

where $\varphi = (\varphi_1, \varphi_2)$, $\dot{\varphi} = (\dot{\varphi}_1, \dot{\varphi}_2)$. The last term corresponds to the energy of the spring. With $L(\varphi, \dot{\varphi}) = K(\dot{\varphi}) - U(\varphi)$ we derive from Lagrange's equations

$$\begin{aligned} m_1 l^2 \ddot{\varphi}_1 + m_1 g l \varphi_1 - k \frac{l^2}{4} (\varphi_2 - \varphi_1) &= 0, \\ m_2 l^2 \ddot{\varphi}_2 + m_2 g l \varphi_2 + k \frac{l^2}{4} (\varphi_2 - \varphi_1) &= 0, \end{aligned} \quad (2.2)$$

which are equivalent to the above equations.

EXAMPLE 2.3. Primitive model of a vehicle. A rigid bar, supported by two springs of stiffnesses k_1 and k_2 , carries out a translational motion of its center of mass S in the vertical direction and a rotation in the plane about S (see Fig. 2.3). Derive the equations of motion for this system.

We see again the typical “engineering” approach to the problem: instead of dealing with a real vehicle with thousands of details and degrees of freedom, we try to select the most important of them.¹ In this simplified model the bar is constrained to have only two degrees of freedom: the vertical motion of S and the rotation in the plane about S. Let the vertical displacement of S from the equilibrium position be x and

¹ This selection depends of course on the aim of our simulations. See also a primitive model of an airplane with three degrees of freedom in exercise 2.12.

the angle of rotation be φ . In the force method we free the bar from the springs and apply Newton's law to it in the x -direction

$$m\ddot{x} = -k_1(x + l_1\varphi) - k_2(x - l_2\varphi).$$

Note that the weight of the bar does not contribute to this equation because it is compensated with the static spring forces. In addition, the moment equation about S for the bar reads

$$J_S\ddot{\varphi} = -k_1l_1(x + l_1\varphi) + k_2l_2(x - l_2\varphi),$$

with J_S being the moment of inertia of the bar about S. The static spring forces do not contribute to this moment equation by the same reason.

To use the energy method we denote by $q = (x, \varphi)$ and $\dot{q} = (\dot{x}, \dot{\varphi})$ and write down the kinetic energy

$$K(\dot{q}) = \frac{1}{2}m\dot{x}^2 + \frac{1}{2}J_S\dot{\varphi}^2,$$

and the potential energy

$$U(q) = \frac{1}{2}k_1(x_{st} + x + l_1\varphi)^2 + \frac{1}{2}k_2(x_{st} + x - l_2\varphi)^2 + mgx,$$

where x_{st} corresponds to the change of length of the springs in the horizontal equilibrium state compared to that in the stress-free state. Expanding the spring energies and taking into account the equilibrium conditions, we see that the linear terms in x and φ are canceled out, so up to a constant,

$$U(q) = \frac{1}{2}k_1(x + l_1\varphi)^2 + \frac{1}{2}k_2(x - l_2\varphi)^2.$$

Thus, we derive again from Lagrange's equations the equations of motion.

Solution. We illustrate the method of solution on example 2.2. To simplify the analysis we consider the special case $m_1 = m_2 = m$. Dividing equations (2.2) by ml^2 , we get

$$\begin{aligned}\ddot{\varphi}_1 + \omega_0^2\varphi_1 - \alpha(\varphi_2 - \varphi_1) &= 0, \\ \ddot{\varphi}_2 + \omega_0^2\varphi_2 + \alpha(\varphi_2 - \varphi_1) &= 0,\end{aligned}\tag{2.3}$$

where

$$\omega_0 = \sqrt{\frac{g}{l}}, \quad \alpha = \frac{k}{4m},$$

with ω_0 being the eigenfrequency of the uncoupled pendulum and α the coupling factor. We seek a particular solution of (2.3) in the form

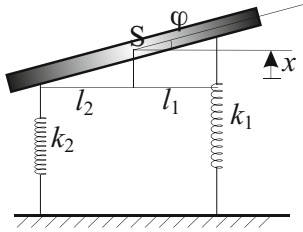

Fig. 2.3 Primitive model of vehicle

$$\varphi_1 = \hat{\varphi}_1 e^{st}, \quad \varphi_2 = \hat{\varphi}_2 e^{st},$$

where $\hat{\varphi}_1$ and $\hat{\varphi}_2$ are unknown constants. Substituting this Ansatz into (2.3), we obtain

$$\begin{aligned} [s^2 \hat{\varphi}_1 + \omega_0^2 \hat{\varphi}_1 - \alpha(\hat{\varphi}_2 - \hat{\varphi}_1)] e^{st} &= 0, \\ [s^2 \hat{\varphi}_2 + \omega_0^2 \hat{\varphi}_2 + \alpha(\hat{\varphi}_2 - \hat{\varphi}_1)] e^{st} &= 0. \end{aligned}$$

Since e^{st} is not equal to zero, the expressions in the square brackets must vanish. We may present these equations in the matrix form as follows

$$\begin{pmatrix} s^2 + \omega_0^2 + \alpha & -\alpha \\ -\alpha & s^2 + \omega_0^2 + \alpha \end{pmatrix} \begin{pmatrix} \hat{\varphi}_1 \\ \hat{\varphi}_2 \end{pmatrix} = \begin{pmatrix} 0 \\ 0 \end{pmatrix}. \quad (2.4)$$

From linear algebra we know that non-trivial solutions of (2.4) exist if its determinant vanishes

$$\begin{vmatrix} s^2 + \omega_0^2 + \alpha & -\alpha \\ -\alpha & s^2 + \omega_0^2 + \alpha \end{vmatrix} = (s^2 + \omega_0^2 + \alpha)^2 - \alpha^2 = 0. \quad (2.5)$$

Equation (2.5), quadratic with respect to s^2 , yields

$$s_1^2 = -\omega_0^2, \quad s_2^2 = -(\omega_0^2 + 2\alpha).$$

Thus, the roots of (2.5) are imaginary numbers given by

$$s_1 = \pm i\omega_1, \quad s_2 = \pm i\omega_2, \quad (2.6)$$

with $\omega_1 = \omega_0$ and $\omega_2 = \sqrt{\omega_0^2 + 2\alpha}$ being called the eigenfrequencies. Note that the amplitudes $\hat{\varphi}_1$ and $\hat{\varphi}_2$ cannot be arbitrary. For example, if $s = s_1$, then (2.4) implies that

$$\hat{\varphi}_1 = \hat{\varphi}_2,$$

or, in the vector form,

$$\hat{\boldsymbol{\varphi}} = \begin{pmatrix} \hat{\varphi}_1 \\ \hat{\varphi}_2 \end{pmatrix} = C_1 \mathbf{q}_1, \quad \mathbf{q}_1 = \frac{1}{\sqrt{2}} \begin{pmatrix} 1 \\ 1 \end{pmatrix}.$$

Thus, the vector $\hat{\boldsymbol{\varphi}}$ is proportional to the eigenvector \mathbf{q}_1 which is normalized to have the length 1. Likewise, for $s = s_2$ we have from (2.4) $\hat{\varphi}_1 = -\hat{\varphi}_2$, or

$$\hat{\boldsymbol{\varphi}} = C_2 \mathbf{q}_2, \quad \mathbf{q}_2 = \frac{1}{\sqrt{2}} \begin{pmatrix} -1 \\ 1 \end{pmatrix}.$$

Note that \mathbf{q}_2 is orthogonal to \mathbf{q}_1 . Because $\mathbf{q}_j e^{st} = \mathbf{q}_j e^{\pm i\omega t}$ satisfy (2.3) which are the differential equations with real coefficients, their real and imaginary parts

$$\mathbf{q}_j \cos \omega t \quad \text{and} \quad \mathbf{q}_j \sin \omega t$$

must satisfy also these equations. The general solution can now be constructed using the linear superposition principle

$$\boldsymbol{\varphi} = \begin{pmatrix} \varphi_1 \\ \varphi_2 \end{pmatrix} = \mathbf{q}_1(A_1 \cos \omega_1 t + B_1 \sin \omega_1 t) + \mathbf{q}_2(A_2 \cos \omega_2 t + B_2 \sin \omega_2 t).$$

The four unknown coefficients A_1 , B_1 and A_2 , B_2 must be found from the initial conditions

$$\boldsymbol{\varphi}(0) = \boldsymbol{\varphi}_0, \quad \dot{\boldsymbol{\varphi}}(0) = \dot{\boldsymbol{\varphi}}_0$$

giving

$$\begin{aligned} A_1 \mathbf{q}_1 + A_2 \mathbf{q}_2 &= \boldsymbol{\varphi}_0, \\ B_1 \omega_1 \mathbf{q}_1 + B_2 \omega_2 \mathbf{q}_2 &= \dot{\boldsymbol{\varphi}}_0. \end{aligned}$$

Then, using the orthogonality of \mathbf{q}_1 and \mathbf{q}_2 , we obtain from here

$$A_j = \boldsymbol{\varphi}_0 \cdot \mathbf{q}_j, \quad B_j = \frac{1}{\omega_j} \dot{\boldsymbol{\varphi}}_0 \cdot \mathbf{q}_j, \quad j = 1, 2,$$

with the dot denoting the scalar product of two vectors. Alternatively, we can present the solution in the form

$$\boldsymbol{\varphi} = \mathbf{q}_1 a_1 \cos(\omega_1 t - \phi_1) + \mathbf{q}_2 a_2 \cos(\omega_2 t - \phi_2). \quad (2.7)$$

Recalling the addition theorem for $\cos(\omega t - \phi)$, we find

$$a_j = \sqrt{A_j^2 + B_j^2}, \quad \tan \phi_j = \frac{B_j}{A_j}, \quad j = 1, 2.$$

For $\alpha \ll 1$ (weak coupling) solution (2.7) exhibits an interesting phenomenon called beating or amplitude modulation (see exercise 2.4).

Normal Modes and Coordinates. As we see from (2.7) the solution is the superposition of two harmonic cosine functions with different frequencies. If the frequency ratio is not a rational number, the motion is no longer periodic in general.² However, for the initial conditions of the special form

$$\varphi_1(0) = \varphi_2(0), \quad \dot{\varphi}_1(0) = \dot{\varphi}_2(0),$$

or

$$\varphi_1(0) = -\varphi_2(0), \quad \dot{\varphi}_1(0) = -\dot{\varphi}_2(0),$$

the motion is purely harmonic with the frequency ω_1 or ω_2 . We call such the special periodic motion normal mode. Fig. 2.4 shows the normal modes corresponding to $\omega = \omega_1$ and $\omega = \omega_2$, respectively. For mode 1 (symmetric mode) the pendulums oscillate in phase, consequently the spring does not change its length and has no

² It is in general *quasi-periodic* (see exercise 2.5).

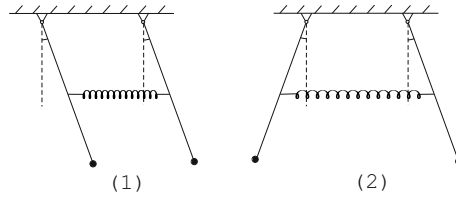

Fig. 2.4 Modes of vibration: 1) $\omega = \omega_1$, 2) $\omega = \omega_2$

influence on the frequency ($\omega = \omega_1 = \omega_0$). For mode 2 (antisymmetric mode) the pendulums oscillate in counter-phases, and the spring stiffness makes the frequency ω_2 higher than ω_1 .

The question now arises: can we find the coordinates in which the normal modes become independent? The first observation is that this holds true if the kinetic and potential energies of the system, in terms of the new coordinates ξ_1 and ξ_2 , take the form

$$K(\dot{\xi}) = \frac{1}{2}(\dot{\xi}_1^2 + \dot{\xi}_2^2), \quad U(\xi) = \frac{1}{2}(\omega_1^2 \xi_1^2 + \omega_2^2 \xi_2^2).$$

Indeed, in this case Lagrange's equations of the system become uncoupled

$$\frac{d}{dt} \frac{\partial L}{\partial \dot{\xi}_j} - \frac{\partial L}{\partial \xi_j} = \ddot{\xi}_j + \omega_j^2 \xi_j = 0, \quad j = 1, 2,$$

yielding two independent modes of vibrations with the frequencies ω_1 and ω_2 . Thus, the answer must be found by the well-known procedure in linear algebra of simultaneously diagonalizing two positive definite quadratic forms [37]. In our simple example we may divide both the kinetic and potential energies by ml^2 to get

$$K(\dot{\varphi}) = \frac{1}{2}(\dot{\varphi}_1^2 + \dot{\varphi}_2^2),$$

and

$$U(\varphi) = \frac{1}{2}\omega_0^2 \varphi_1^2 + \frac{1}{2}\omega_0^2 \varphi_2^2 + \frac{1}{2}\alpha(\varphi_2 - \varphi_1)^2.$$

These formulas suggest the following obvious choice of normal coordinates

$$\xi_1 = \frac{1}{\sqrt{2}}(\varphi_1 + \varphi_2), \quad \xi_2 = \frac{1}{\sqrt{2}}(\varphi_2 - \varphi_1).$$

In terms of the new coordinates we have

$$K(\dot{\xi}) = \frac{1}{2}(\dot{\xi}_1^2 + \dot{\xi}_2^2), \quad U(\xi) = \frac{1}{2}[\omega_0^2 \xi_1^2 + (\omega_0^2 + 2\alpha)\xi_2^2],$$

so this is the Lagrange function of two independent oscillators with the frequencies ω_1 and ω_2 . We will see later that the reduction of a general conservative oscillator with n degrees of freedom to n uncoupled single oscillators is possible and

realized by a linear transformation which simultaneously diagonalize the kinetic and potential energies as quadratic forms.

2.2 Dissipative Oscillators

Differential Equations of Motion. We have seen from the previous Sections that, although both the force and the energy methods are equivalent, the latter turns out to be more advantageous for systems with many degrees of freedom. Since we are now familiar with the energy method and convinced in its equivalence with the force method, we shall use exclusively the former to derive the equations of motion.

EXAMPLE 2.4. Mass-spring-damper oscillators. Two masses m_1 and m_2 move horizontally under the action of two massless springs of stiffnesses k_1 and k_2 and two dampers of damping constants c_1, c_2 (see Fig. 2.5). Derive the equations of motion for these coupled oscillators.

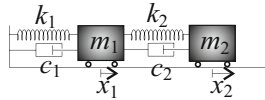

Fig. 2.5 Mass-spring-damper oscillators with two degrees of freedom

Let x_1 and x_2 be the displacements from the equilibrium positions of the masses m_1 and m_2 , respectively. Similar to example 2.1 the Lagrange function reads

$$L(x, \dot{x}) = \frac{1}{2}m_1\dot{x}_1^2 + \frac{1}{2}m_2\dot{x}_2^2 - \frac{1}{2}k_1x_1^2 - \frac{1}{2}k_2(x_2 - x_1)^2.$$

With the dissipation function

$$D(\dot{x}) = \frac{1}{2}c_1\dot{x}_1^2 + \frac{1}{2}c_2(\dot{x}_2 - \dot{x}_1)^2,$$

we derive from modified Lagrange's equations

$$\frac{d}{dt} \frac{\partial L}{\partial \dot{x}_j} - \frac{\partial L}{\partial x_j} + \frac{\partial D}{\partial \dot{x}_j} = 0, \quad j = 1, 2$$

the equations of motion

$$\begin{aligned} m_1\ddot{x}_1 + c_1\dot{x}_1 - c_2(\dot{x}_2 - \dot{x}_1) + k_1x_1 - k_2(x_2 - x_1) &= 0, \\ m_2\ddot{x}_2 + c_2(\dot{x}_2 - \dot{x}_1) + k_2(x_2 - x_1) &= 0. \end{aligned} \tag{2.8}$$

EXAMPLE 2.5. Coupled pendulums with spring and damper. Two pendulums are connected with each other by a spring of stiffness k and a damper of damping constant c (see Fig. 2.6). Derive the equations of small vibration for this system.

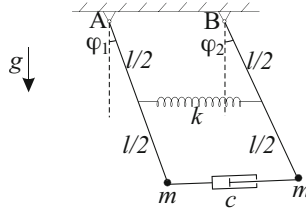

Fig. 2.6 Coupled damped pendulums

Similar to example 2.2 the Lagrange function is given by

$$L(\varphi, \dot{\varphi}) = \frac{1}{2}ml^2\dot{\varphi}_1^2 + \frac{1}{2}ml^2\dot{\varphi}_2^2 - \frac{1}{2}mgl\varphi_1^2 - \frac{1}{2}mgl\varphi_2^2 - \frac{1}{2}k(l(\varphi_2 - \varphi_1)/2)^2. \quad (2.9)$$

The dissipation function reads

$$D(\dot{\varphi}) = \frac{1}{2}cl^2(\dot{\varphi}_2 - \dot{\varphi}_1)^2. \quad (2.10)$$

From modified Lagrange's equations

$$\frac{d}{dt} \frac{\partial L}{\partial \dot{\varphi}_j} - \frac{\partial L}{\partial \varphi_j} + \frac{\partial D}{\partial \dot{\varphi}_j} = 0, \quad j = 1, 2,$$

we derive the equations of motion

$$\begin{aligned} ml^2\ddot{\varphi}_1 - cl^2(\ddot{\varphi}_2 - \ddot{\varphi}_1) + mgl\varphi_1 - k\frac{l^2}{4}(\varphi_2 - \varphi_1) &= 0, \\ ml^2\ddot{\varphi}_2 + cl^2(\ddot{\varphi}_2 - \ddot{\varphi}_1) + mgl\varphi_2 + k\frac{l^2}{4}(\varphi_2 - \varphi_1) &= 0. \end{aligned} \quad (2.11)$$

EXAMPLE 2.6. Damped vehicle. A rigid bar, connected with two springs of stiffnesses k_1 and k_2 and a damper with the damping force acting in the center of mass S, performs a translational motion of S in the vertical direction and a rotation in the plane about S (see Fig. 2.7). Derive the equations of motion for this damped vehicle.

Let $q = (x, \varphi)$ and $\dot{q} = (\dot{x}, \dot{\varphi})$. We write down the Lagrange function as in example 2.3

$$L(q, \dot{q}) = \frac{1}{2}m\dot{x}^2 + \frac{1}{2}J_S\dot{\varphi}^2 - \frac{1}{2}k_1(x + l_1\varphi)^2 - \frac{1}{2}k_2(x - l_2\varphi)^2.$$

Furthermore, the dissipation function reads

$$D(\dot{q}) = \frac{1}{2}c\dot{x}^2.$$

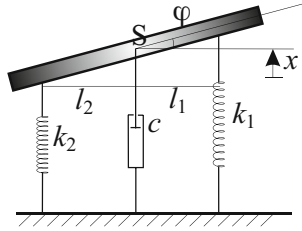

Fig. 2.7 Damped vehicle

Now, from modified Lagrange's equations

$$\frac{d}{dt} \frac{\partial L}{\partial \dot{q}_j} - \frac{\partial L}{\partial q_j} + \frac{\partial D}{\partial \dot{q}_j} = 0, \quad j = 1, 2,$$

we derive the equations of motion

$$\begin{aligned} m\ddot{x} + c\dot{x} + k_1(x + l_1\varphi) + k_2(x - l_2\varphi) &= 0, \\ J_S\ddot{\varphi} + k_1l_1(x + l_1\varphi) - k_2l_2(x - l_2\varphi) &= 0. \end{aligned} \quad (2.12)$$

Classification of Damping. Let \mathbf{q} be the column vector whose components are the generalized coordinates. In our examples 2.4, 2.5, and 2.6 it is

$$\mathbf{q} = \begin{pmatrix} x_1 \\ x_2 \end{pmatrix}, \quad \mathbf{q} = \begin{pmatrix} \varphi_1 \\ \varphi_2 \end{pmatrix}, \quad \mathbf{q} = \begin{pmatrix} x \\ \varphi \end{pmatrix},$$

respectively. The equations of motion derived above can be written in the matrix form as follows

$$\mathbf{M}\ddot{\mathbf{q}} + \mathbf{C}\dot{\mathbf{q}} + \mathbf{K}\mathbf{q} = \mathbf{0}, \quad (2.13)$$

where the matrices \mathbf{M} , \mathbf{C} , and \mathbf{K} are called mass, damping, and stiffness matrices, respectively. For instance, in example 2.6 we have

$$\mathbf{M} = \begin{pmatrix} m & 0 \\ 0 & J_S \end{pmatrix}, \quad \mathbf{C} = \begin{pmatrix} c & 0 \\ 0 & 0 \end{pmatrix}, \quad \mathbf{K} = \begin{pmatrix} k_1 + k_2 & k_1l_1 - k_2l_2 \\ k_1l_1 - k_2l_2 & k_1l_1^2 + k_2l_2^2 \end{pmatrix}.$$

In general, all three matrices \mathbf{M} , \mathbf{C} , and \mathbf{K} are symmetric. The symmetry of \mathbf{C} follows from the formula for the damping forces

$$Q_j = -\frac{\partial D}{\partial \dot{q}_j},$$

and from the fact that D is quadratic with respect to $\dot{\mathbf{q}}$. In thermodynamics of irreversible processes this symmetry property is the consequence of Onsager's

principle. The mass matrix \mathbf{M} is always positive definite in the sense that there exists a positive constant m such that the inequality

$$\mathbf{q} \cdot \mathbf{M}\mathbf{q} \geq m\mathbf{q} \cdot \mathbf{q}$$

holds true for arbitrary \mathbf{q} . If the system does not permit rigid-body motions, then the stiffness matrix \mathbf{K} is also positive definite. Concerning the damping matrix \mathbf{C} we may merely assume in general its non-negative definiteness in the sense that

$$\mathbf{q} \cdot \mathbf{C}\mathbf{q} \geq 0$$

for arbitrary \mathbf{q} . Note, however, that in reality, if the resistance to motion through the viscous damping of the air or through the internal damping affecting all degrees of freedom is taken into account, then \mathbf{C} must also be positive definite.

We call the damping exhaustive if the damping matrix \mathbf{C} is positive definite. In this case all motions decay exponentially. If there exists some \mathbf{q} such that $\mathbf{q} \cdot \mathbf{C}\mathbf{q} = 0$, but nevertheless all motions of the system decay exponentially, the damping is called permeating. If there exists some vibration mode which does not decay with time, the damping is called non-permeating. The damping is called proportional if

$$\mathbf{C} = \alpha\mathbf{M} + \beta\mathbf{K}. \quad (2.14)$$

According to this classification the damping in example 2.4 is exhaustive, and if $c_1 = \beta k_1$, $c_2 = \beta k_2$, then it is proportional. In example 2.5 the damping is obviously proportional, but non-exhaustive and non-permeating: the dissipation vanishes for $\varphi_1 = \varphi_2$, and this mode of vibration does not decay with time. In example 2.6 the damping is non-exhaustive but permeating as long as the coupling factor $k_1 l_1 - k_2 l_2$ is not equal to zero. Indeed, if $x(t)$ decays exponentially with time, then it follows from (2.12)₁ that $\varphi(t)$ should also decay exponentially if $k_1 l_1 - k_2 l_2$ is not equal to zero.

Solution. We analyze two cases.

Proportional damping. In this case we may choose the normal coordinates which diagonalize all three matrices \mathbf{M} , \mathbf{C} , and \mathbf{K} simultaneously and by this reduce the system to two independent damped oscillators. We illustrate this on example 2.5. Dividing the Lagrange function and the dissipation function by ml^2 and choosing the normal coordinates

$$\xi_1 = \frac{1}{\sqrt{2}}(\varphi_1 + \varphi_2), \quad \xi_2 = \frac{1}{\sqrt{2}}(\varphi_2 - \varphi_1),$$

we obtain

$$L(\xi, \dot{\xi}) = \frac{1}{2}(\dot{\xi}_1^2 + \dot{\xi}_2^2) - \frac{1}{2}(\omega_1^2 \xi_1^2 + \omega_2^2 \xi_2^2), \quad (2.15)$$

and

$$D(\dot{\xi}) = \frac{c}{m} \dot{\xi}_2^2. \quad (2.16)$$

In terms of the new coordinates modified Lagrange's equations become

$$\begin{aligned}\ddot{\xi}_1 + \omega_1^2 \xi_1 &= 0, \\ \ddot{\xi}_2 + \frac{2c}{m} \dot{\xi}_2 + \omega_2^2 \xi_2 &= 0.\end{aligned}$$

Thus, we see that the motions $\xi_1(t)$ and $\xi_2(t)$ are independent, and the motion $\xi_1(t)$ is harmonic confirming that the damping in this example is non-permeating. The obtained uncoupled equations can be solved by the method discussed in Section 1.2.

Non-proportional damping. We illustrate the method of solution on example 2.6. Dividing the equations of motion (2.12) by m and J_s , respectively, and introducing the notations

$$\begin{aligned}\frac{k_1 + k_2}{m} &= \omega_x^2, & \frac{k_1 l_1^2 + k_2 l_2^2}{J_s} &= \omega_\phi^2, & \frac{c}{m} &= \chi, \\ \frac{k_1 l_1 - k_2 l_2}{m} &= \alpha_1^2, & \frac{k_1 l_1 - k_2 l_2}{J_s} &= \alpha_2^2, & \alpha_1^2 \alpha_2^2 &= \alpha^4,\end{aligned}$$

with ω_x and ω_ϕ being the frequencies of uncoupled vibrations and α the coupling factor, we transform (2.12) to

$$\begin{aligned}\ddot{x} + \chi \dot{x} + \omega_x^2 x + \alpha_1^2 \varphi &= 0, \\ \ddot{\varphi} + \omega_\phi^2 \varphi + \alpha_2^2 x &= 0.\end{aligned}\tag{2.17}$$

We seek a particular solution of (2.17) in the form

$$x = \hat{x} e^{st}, \quad \varphi = \hat{\varphi} e^{st}.$$

Substituting this Ansatz into (2.17) and eliminating the factor e^{st} we obtain the linear equations

$$\begin{pmatrix} s^2 + \chi s + \omega_x^2 & \alpha_1^2 \\ \alpha_2^2 & s^2 + \omega_\phi^2 \end{pmatrix} \begin{pmatrix} \hat{x} \\ \hat{\varphi} \end{pmatrix} = \begin{pmatrix} 0 \\ 0 \end{pmatrix}.\tag{2.18}$$

Non-trivial solutions of this system exist if the determinant vanishes

$$\begin{vmatrix} s^2 + \chi s + \omega_x^2 & \alpha_1^2 \\ \alpha_2^2 & s^2 + \omega_\phi^2 \end{vmatrix} = 0.$$

This yields the characteristic equation

$$s^4 + \chi s^3 + (\omega_x^2 + \omega_\phi^2) s^2 + \chi \omega_\phi^2 s + \omega_x^2 \omega_\phi^2 - \alpha^4 = 0,\tag{2.19}$$

which is the algebraic equation of fourth order with respect to s .

Since (2.19) is the equation with real coefficients, the complex roots occur in pairs of complex conjugates. We want first to show that all roots have negative real parts. According to the Routh-Hurwitz criterion [19] this is the case if

$$T_0 = a_0 > 0, \quad T_1 = a_1 > 0, \quad T_2 = \begin{vmatrix} a_1 & a_0 \\ a_3 & a_2 \end{vmatrix} > 0,$$

$$T_3 = \begin{vmatrix} a_1 & a_0 & 0 \\ a_3 & a_2 & a_1 \\ 0 & a_4 & a_3 \end{vmatrix} > 0, \quad T_4 = \begin{vmatrix} a_1 & a_0 & 0 & 0 \\ a_3 & a_2 & a_1 & a_0 \\ 0 & a_4 & a_3 & a_2 \\ 0 & 0 & 0 & a_4 \end{vmatrix} = a_4 T_3 > 0,$$

where

$$a_0 = 1, \quad a_1 = \chi, \quad a_2 = \omega_x^2 + \omega_\phi^2, \quad a_3 = \chi \omega_\phi^2, \quad a_4 = \omega_x^2 \omega_\phi^2 - \alpha^4$$

are the coefficients of the characteristic equation. Elementary calculations give

$$T_0 = 1 > 0, \quad T_1 = \chi > 0, \quad T_2 = \chi \omega_x^2 > 0,$$

$$T_3 = \chi^2 (\omega_x^2 + \omega_\phi^2 + \omega_x^2 \omega_\phi^2 + \alpha^4) > 0, \quad T_4 = (\omega_x^2 \omega_\phi^2 - \alpha^4) T_3 > 0,$$

so the Routh-Hurwitz criterion is fulfilled.

Although the characteristic equation can be solved in closed analytical form, the analysis of exact solution is rather tedious. We therefore consider the case of small damping $\chi \ll \omega_x$, $\chi \ll \omega_\phi$ and seek s in the form $s = (-\kappa \pm i)\omega$, where $\kappa \ll 1$. Then to the first approximation

$$s^2 \approx -(1 \pm 2\kappa i)\omega^2, \quad s^3 \approx (3\kappa \mp i)\omega^3, \quad s^4 \approx (1 \pm 4\kappa i)\omega^4.$$

Substituting this into (2.19) and neglecting the powers of χ and κ higher than one, we obtain in the first approximation

$$\omega^4 - (\omega_x^2 + \omega_\phi^2)\omega^2 + \omega_x^2 \omega_\phi^2 - \alpha^4$$

$$\pm i[4\kappa\omega^4 - \chi\omega^3 - 2\kappa(\omega_x^2 + \omega_\phi^2)\omega^2 + \chi\omega\omega_\phi^2] = 0.$$

This complex expression is zero if its real and imaginary parts vanish. So, we obtain two equations determining the eigenfrequencies $\omega_{1,2}$ and the decay rates $\kappa_{1,2}\omega_{1,2}$. Note that the equation for the eigenfrequencies

$$\omega^4 - (\omega_x^2 + \omega_\phi^2)\omega^2 + \omega_x^2 \omega_\phi^2 - \alpha^4 = 0$$

is identical with that of the undamped vehicle in example 2.3. Thus, for small damping the eigenfrequencies remain the same as those of the undamped coupled oscillators which are given by

$$\omega_{1,2}^2 = \frac{1}{2}(\omega_x^2 + \omega_\phi^2) \mp \sqrt{\frac{1}{4}(\omega_x^2 - \omega_\phi^2)^2 + \alpha^4}.$$

Fig. 2.8 shows the plots of dimensionless frequencies $(\omega_{1,2}/\omega_x)^2$ versus the ratio of frequencies $(\omega_\phi/\omega_x)^2$ at different coupling ratios $(\alpha/\omega_x)^2$. It can be seen that for the zero coupling $\alpha = 0$ the eigenfrequencies coincide with those of uncoupled

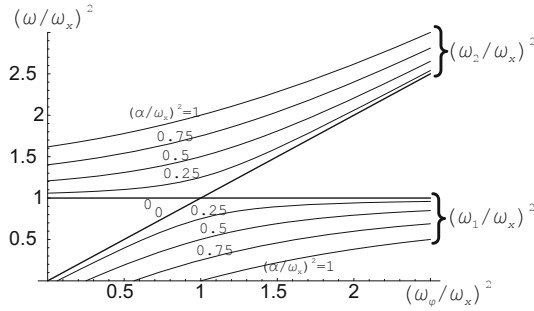

Fig. 2.8 Eigenfrequencies $(\omega_{1,2}/\omega_x)^2$ vs. ratio of uncoupled frequencies $(\omega_\phi/\omega_x)^2$ at different coupling ratios $(\alpha/\omega_x)^2$

oscillators ω_ϕ and ω_x . The larger the coupling factor, the farther the eigenfrequencies lie apart. The frequency ω_2 is always larger than the largest from ω_ϕ and ω_x , while ω_1 is smaller than the smallest from them.

The decay rates $\kappa_{1,2}\omega_{1,2}$ should be determined from the equation

$$4\kappa\omega^4 - \chi\omega^3 - 2\kappa(\omega_x^2 + \omega_\phi^2)\omega^2 + \chi\omega\omega_\phi^2 = 0$$

giving

$$\kappa_1\omega_1 = \frac{\chi(\omega_1^2 - \omega_\phi^2)}{4\omega_1^2 - 2(\omega_x^2 + \omega_\phi^2)}, \quad \kappa_2\omega_2 = \frac{\chi(\omega_2^2 - \omega_\phi^2)}{4\omega_2^2 - 2(\omega_x^2 + \omega_\phi^2)}.$$

Thus, the decay rates are positive and are of the same order as χ .

By substituting s found above into (2.18) we may establish the relations between the amplitudes of vibrations. For $s = (-\kappa_i \pm i)\omega_i$ we have

$$\hat{\mathbf{q}} = \begin{pmatrix} \hat{x} \\ \hat{\phi} \end{pmatrix} = C \begin{pmatrix} (1 \pm 2i\kappa_i)\omega_i^2 - \omega_\phi^2 \\ \alpha_i^2 \end{pmatrix}, \quad i = 1, 2.$$

Denoting by \mathbf{q}_1 and \mathbf{q}_2 the complex-valued vectors

$$\mathbf{q}_1 = \begin{pmatrix} (1 + 2i\kappa_1)\omega_1^2 - \omega_\phi^2 \\ \alpha_1^2 \end{pmatrix}, \quad \mathbf{q}_2 = \begin{pmatrix} (1 + 2i\kappa_2)\omega_2^2 - \omega_\phi^2 \\ \alpha_2^2 \end{pmatrix},$$

we may present the general solution of (2.17) in the form

$$\mathbf{q} = e^{-\kappa_1\omega_1 t} (A_1 \mathbf{q}_1 e^{i\omega_1 t} + B_1 \mathbf{q}_1^* e^{-i\omega_1 t}) + e^{-\kappa_2\omega_2 t} (A_2 \mathbf{q}_2 e^{i\omega_2 t} + B_2 \mathbf{q}_2^* e^{-i\omega_2 t}),$$

where asterisks denote complex conjugates. The four unknown real constants A_1 , B_1 , A_2 , and B_2 must be determined from the initial conditions.

2.3 Forced Oscillators and Vibration Control

Differential Equations of Motion. We illustrate the derivation of the equations of forced vibrations for systems with two degrees of freedom.

EXAMPLE 2.7. Mass-spring forced oscillators. The mass-spring oscillators with two degrees of freedom are excited by the motion of the end-point $x_e(t)$. Derive the equations of motion for these forced oscillators.

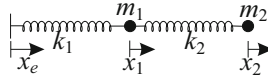

Fig. 2.9 Mass-spring forced oscillators

Since the change in length of the first spring is $x_1 - x_e$, we write for the Lagrange function

$$L(x, \dot{x}) = \frac{1}{2}m_1\dot{x}_1^2 + \frac{1}{2}m_2\dot{x}_2^2 - \frac{1}{2}k_1(x_1 - x_e)^2 - \frac{1}{2}k_2(x_2 - x_1)^2.$$

This Lagrange function differs from that of example 2.1 only by the third term corresponding to the energy of the first spring. From Lagrange's equations we derive

$$\begin{aligned} m_1\ddot{x}_1 + k_1(x_1 - x_e) - k_2(x_2 - x_1) &= 0, \\ m_2\ddot{x}_2 + k_2(x_2 - x_1) &= 0. \end{aligned}$$

Bringing the term $-k_1x_e$ to the right-hand side we obtain

$$\begin{aligned} m_1\ddot{x}_1 + k_1x_1 - k_2(x_2 - x_1) &= k_1x_e(t), \\ m_2\ddot{x}_2 + k_2(x_2 - x_1) &= 0. \end{aligned} \tag{2.20}$$

EXAMPLE 2.8. Mass-spring-damper forced oscillators. The mass-spring-damper oscillators with two degrees of freedom are excited by the force $f(t)$ acting on the mass m_1 (see Fig. 2.8). Derive the equations of motion for these forced oscillators.

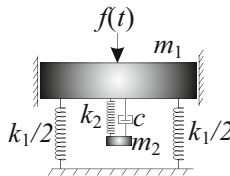

Fig. 2.10 Mass-spring-damper forced oscillators

We denote by x_1 and x_2 the displacements of m_1 and m_2 in the vertical direction from their equilibrium positions, respectively. Then the Lagrange function equals

$$L(x, \dot{x}) = \frac{1}{2}m_1\dot{x}_1^2 + \frac{1}{2}m_2\dot{x}_2^2 - \frac{1}{2}k_1x_1^2 - \frac{1}{2}k_2(x_2 - x_1)^2,$$

while the dissipation function is

$$D(\dot{x}) = \frac{1}{2}c(\dot{x}_2 - \dot{x}_1)^2.$$

From modified Lagrange's equations for the forced vibrations

$$\frac{d}{dt} \frac{\partial L}{\partial \dot{x}_j} - \frac{\partial L}{\partial x_j} + \frac{\partial D}{\partial \dot{x}_j} = f_j(t), \quad j = 1, 2,$$

with $f_j(t)$ being the external forces acting on the masses m_j , we derive

$$\begin{aligned} m_1\ddot{x}_1 - c(\dot{x}_2 - \dot{x}_1) + k_1x_1 - k_2(x_2 - x_1) &= f(t), \\ m_2\ddot{x}_2 + c(\dot{x}_2 - \dot{x}_1) + k_2(x_2 - x_1) &= 0. \end{aligned} \tag{2.21}$$

EXAMPLE 2.9. Coupled forced pendulums. The coupled pendulums as in example 2.5 are excited by a force $p(t)$ acting on the second mass (see Fig. 2.11). Derive the equations of motion for these coupled forced pendulums.

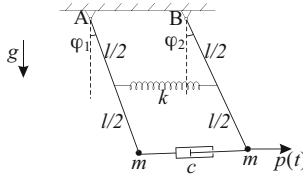

Fig. 2.11 Coupled forced pendulums

Similar to example 2.5 the Lagrange function is given by (2.9), while the dissipation function by (2.10). The virtual work done by the external force $p(t)$ is

$$\delta A = \int_{t_0}^{t_1} p(t)l\delta\varphi_2 dt.$$

From modified Lagrange's equations

$$\frac{d}{dt} \frac{\partial L}{\partial \dot{\varphi}_j} - \frac{\partial L}{\partial \varphi_j} + \frac{\partial D}{\partial \dot{\varphi}_j} = f_j(t), \quad j = 1, 2,$$

we derive the equations of motion

$$\begin{aligned} ml^2 \ddot{\phi}_1 - cl^2(\dot{\phi}_2 - \dot{\phi}_1) + mgl\phi_1 - k\frac{l^2}{4}(\phi_2 - \phi_1) &= 0, \\ ml^2 \ddot{\phi}_2 + cl^2(\dot{\phi}_2 - \dot{\phi}_1) + mgl\phi_2 + k\frac{l^2}{4}(\phi_2 - \phi_1) &= p(t)l. \end{aligned} \quad (2.22)$$

Harmonic Excitations. Equations of motion derived above are the inhomogeneous linear differential equations of second order. The solution of these linear equations is the sum of any particular solution of the inhomogeneous equations and the general solution of the homogeneous equations which has been found in previous Section. Thus, it is enough to find any particular solution of the inhomogeneous equations. For the harmonic excitations this can be done directly. We consider two cases.

Conservative oscillators. We illustrate the method of solution on example 2.7, where the excitation is assumed in the form: $x_e(t) = \hat{x}_e \cos(\omega t)$. Dividing the first and the second equations of (2.20) by m_1 and m_2 , respectively, we rewrite them in the form

$$\begin{aligned} \ddot{x}_1 + v_1^2 x_1 - \mu v_2^2 x_2 &= v_{10}^2 \hat{x}_e \cos(\omega t), \\ \ddot{x}_2 + v_2^2 x_2 - v_2^2 x_1 &= 0, \end{aligned}$$

where

$$v_1^2 = \frac{k_1 + k_2}{m_1}, \quad v_2^2 = \frac{k_2}{m_2}, \quad \mu = \frac{m_2}{m_1}, \quad v_{10}^2 = \frac{k_1}{m_1}.$$

Since the first derivatives \dot{x}_1 and \dot{x}_2 do not enter the equations of motion, we seek a particular solution of these inhomogeneous differential equations in the form

$$x_1 = \hat{x}_1 \cos \omega t, \quad x_2 = \hat{x}_2 \cos \omega t.$$

Substituting this Ansatz into the above equations and eliminating the common factor $\cos \omega t$ on both sides, we obtain

$$\begin{aligned} (v_1^2 - \omega^2)\hat{x}_1 - \mu v_2^2 \hat{x}_2 &= v_{10}^2 \hat{x}_e, \\ -v_2^2 \hat{x}_1 + (v_2^2 - \omega^2)\hat{x}_2 &= 0. \end{aligned} \quad (2.23)$$

Thus, the amplitudes of forced vibration are given by

$$\begin{aligned} \hat{x}_1 &= \frac{v_{10}^2 (v_2^2 - \omega^2) \hat{x}_e}{(v_1^2 - \omega^2)(v_2^2 - \omega^2) - \mu v_2^4}, \\ \hat{x}_2 &= \frac{v_{10}^2 v_2^2 \hat{x}_e}{(v_1^2 - \omega^2)(v_2^2 - \omega^2) - \mu v_2^4}. \end{aligned}$$

The behavior of the amplitudes, as functions of the frequency ω , is characterized by the zeros of the denominator and the numerator. The denominator vanishes for

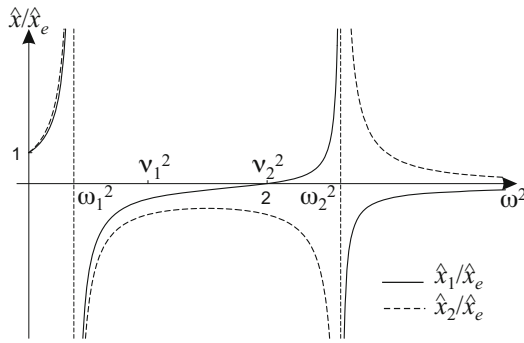

Fig. 2.12 Resonance curves of mass-spring forced oscillators

$$\omega_{1,2}^2 = \frac{1}{2}(v_1^2 + v_2^2) \mp \sqrt{\frac{1}{4}(v_1^2 - v_2^2)^2 + \mu v_2^4},$$

which correspond to the eigenfrequencies of free vibration of this system. We see that the eigenfrequencies ω_1 and ω_2 always lie outside the frequency range (v_1, v_2) . The plot of resonance functions \hat{x}_i/\hat{x}_e versus ω^2 is shown in Fig. 2.12. These resonance functions tend to infinity as ω approaches one of the frequencies ω_1 and ω_2 , corresponding to the resonances, and to zero as $\omega \rightarrow \infty$. While $\hat{x}_2/\hat{x}_e \neq 0$ for all frequencies, the amplitude \hat{x}_1 vanishes at $\omega = v_2$. This phenomenon is called anti-resonance (or vibration elimination) and the mass m_2 together with the spring k_2 a vibration eliminator. The elimination of forced vibration can be explained physically as follows. At the frequency $\omega = v_2$ the eliminator and the excitation vibrate in counter-phases such that the spring force acting on m_1 from the eliminator is equal and opposite to the exciting force $k_1\hat{x}_e \cos \omega t$. Indeed, equations (2.23) at $\omega = v_2$ yield

$$\hat{x}_2 = -\frac{v_{10}^2 \hat{x}_e}{\mu v_2^2} = -\frac{k_1}{k_2} \hat{x}_e.$$

Thus, the resultant force acting on m_1 is zero and therefore that mass does not vibrate. To eliminate the unwanted forced vibration of m_1 caused by some excitation source with the fixed frequency ω we must therefore choose the mass and the spring of the eliminator in such a relation that $\sqrt{k_2/m_2} = \omega$. However, if the excitation source has a wider range of frequencies, this choice is no longer effective because, as it is seen from Fig. 2.12, the resonance function \hat{x}_1/\hat{x}_e increases rapidly as ω deviates from v_2 .

Damped oscillators. We see from the previous example that the elimination of forced vibration for the conservative oscillators is effective only if the excitation source has a constant frequency. In the case of non-zero damping the situation changes. We illustrate the method of solution on example 2.8, where the external force is assumed in the form $f(t) = \hat{f} \cos(\omega t)$. We rewrite equations (2.21) in the matrix form

$$\mathbf{M}\ddot{\mathbf{x}} + \mathbf{C}\dot{\mathbf{x}} + \mathbf{K}\mathbf{x} = \hat{\mathbf{f}}\cos(\omega t), \quad (2.24)$$

where

$$\mathbf{M} = \begin{pmatrix} m_1 & 0 \\ 0 & m_2 \end{pmatrix}, \quad \mathbf{C} = \begin{pmatrix} c & -c \\ -c & c \end{pmatrix}, \quad \mathbf{K} = \begin{pmatrix} k_1 + k_2 & -k_2 \\ -k_2 & k_2 \end{pmatrix}, \quad \mathbf{x} = \begin{pmatrix} x_1 \\ x_2 \end{pmatrix}, \quad \hat{\mathbf{f}} = \begin{pmatrix} \hat{f} \\ 0 \end{pmatrix}.$$

Now, the Ansatz $\mathbf{x} = \hat{\mathbf{x}}\cos(\omega t)$ with real $\hat{\mathbf{x}}$ does not work because the first derivative in (2.24) brings terms with the factor $\sin(\omega t)$. However, we may do the following “trick” to get the solution quickly. We regard the right-hand side of (2.24) as $\hat{\mathbf{f}}\cos(\omega t) = \operatorname{Re}(\hat{\mathbf{f}}e^{i\omega t})$ and consider instead the following auxiliary equation

$$\mathbf{M}\dot{\mathbf{z}} + \mathbf{C}\mathbf{z} + \mathbf{K}\mathbf{z} = \hat{\mathbf{f}}e^{i\omega t}. \quad (2.25)$$

Now \mathbf{z} may be complex-valued. Then we substitute the Ansatz $\mathbf{z} = \hat{\mathbf{z}}e^{i\omega t}$ into this equation and eliminate the common factor $e^{i\omega t}$ to obtain

$$(-\omega^2\mathbf{M} + i\omega\mathbf{C} + \mathbf{K})\hat{\mathbf{z}} = \hat{\mathbf{f}}.$$

Provided the matrix on the left-hand side has an inverse, this equation yields

$$\hat{\mathbf{z}} = (-\omega^2\mathbf{M} + i\omega\mathbf{C} + \mathbf{K})^{-1}\hat{\mathbf{f}} = \mathbf{G}(\omega)\hat{\mathbf{f}}.$$

Matrix $\mathbf{G}(\omega)$ is called a transmittance matrix of the system. Since $\hat{\mathbf{z}}e^{i\omega t}$ is the solution of (2.25) which is the equation with real matrices, its real part must satisfy equation (2.24). So, the trick works!

Thus, the particular solution of (2.24) is

$$\mathbf{x}(t) = \operatorname{Re}(\hat{\mathbf{z}}e^{i\omega t}),$$

or, in components,

$$x_j(t) = \operatorname{Re}(\hat{z}_j e^{i\omega t}), \quad j = 1, 2.$$

Since each complex number z can be presented as $z = |z|e^{-i\phi}$, we obtain from here

$$x_j = |\hat{z}_j| \cos(\omega t - \phi_j), \quad j = 1, 2.$$

With the matrices given above we may calculate the amplitude of x_1

$$|x_1| = |\hat{z}_1| = \left| \frac{\hat{f}(-m_2\omega^2 + i\omega c + k_2)}{(-m_1\omega^2 + i\omega c + k_1 + k_2)(-m_2\omega^2 + i\omega c + k_2) - (i\omega c + k_2)^2} \right|.$$

Dividing both the numerator and the denominator by k_1^2 and introducing

$$x_{10} = \frac{\hat{f}}{k_1}, \quad \omega_0 = \sqrt{\frac{k_1}{m_1}}, \quad \kappa = \frac{k_2}{k_1}, \quad \mu = \frac{m_2}{m_1}, \quad \eta = \frac{\omega}{\omega_0}, \quad \delta = \frac{c}{m_1\omega_0},$$

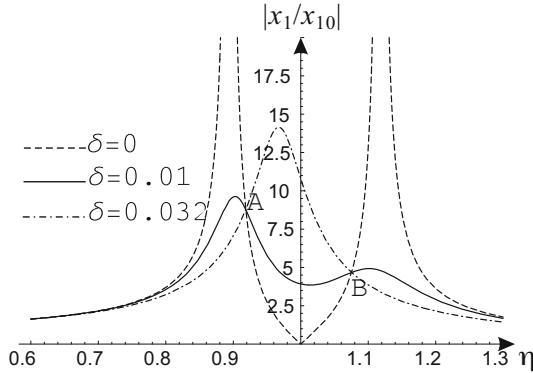

Fig. 2.13 Resonance curves of mass-spring-damper forced oscillators

we present the previous equation in the dimensionless form as follows

$$\left| \frac{x_1}{x_{10}} \right| = \left| \frac{-\mu\eta^2 + i\delta\eta + \kappa}{(-\eta^2 + i\delta\eta + 1 + \kappa)(-\mu\eta^2 + i\delta\eta + \kappa) - (i\delta\eta + \kappa)^2} \right|,$$

where the right-hand side is called a resonance function.

Fig. 2.13 shows the resonance curves $|x_1/x_{10}|$ against the frequency ratio $\eta = \omega/\omega_0$ for $\mu = \kappa = 0.05$ and for three damping ratios $\delta = 0$ (dashed line), $\delta = 0.01$ (bold line), $\delta = 0.032$ (dotted line) [48]. In contrast to the conservative oscillators ($\delta = 0$), neither resonance nor vibration elimination is observed for the damped forced oscillators with the finite damping. We call therefore the mass m_2 together with the spring k_2 and the damper c a vibration absorber. It turns out that all resonance curves corresponding to different damping ratios intersect at the two fixed points A and B (see exercise 2.8). If we want to reduce the maxima of the resonance curve in equal way, then an optimal choice of the parameters of absorber is achieved when points A and B are at equal level. This takes place when

$$\kappa = \frac{\mu}{(1 + \mu)^2}.$$

Arbitrary Excitations. We illustrate the method of solution on example 2.9 for which the proportional damping holds true. The more general non-proportional damping case will be considered in Section 2.5. The coupled forced oscillators with the proportional damping can always be reduced to the uncoupled single forced oscillators. Indeed, in this example we choose the normal coordinates as

$$\xi_1 = \frac{1}{\sqrt{2}}(\varphi_1 + \varphi_2), \quad \xi_2 = \frac{1}{\sqrt{2}}(\varphi_2 - \varphi_1),$$

and present the normalized virtual work in the form

$$\frac{1}{ml^2} \delta A = \int_{t_0}^{t_1} \frac{p(t)}{ml} \delta \varphi_2 dt = \int_{t_0}^{t_1} \frac{p(t)}{ml} \frac{1}{\sqrt{2}} (\delta \xi_1 + \delta \xi_2) dt.$$

Together with the Lagrange function (2.15) and the dissipation function (2.16) we derive modified Lagrange's equations

$$\begin{aligned} \ddot{\xi}_1 + \omega_1^2 \xi_1 &= \frac{1}{\sqrt{2}} \frac{p(t)}{ml}, \\ \ddot{\xi}_2 + \frac{2c}{m} \dot{\xi}_2 + \omega_2^2 \xi_2 &= \frac{1}{\sqrt{2}} \frac{p(t)}{ml}, \end{aligned}$$

which can be solved by the Laplace transform as shown in Section 1.3.

2.4 Variational Principles

We present in this Section the variational principles for general systems having n degrees of freedom [29]. For small vibrations about equilibrium states the energy and dissipation become quadratic with respect to the generalized coordinates and velocities, so that generalized Lagrange's equations become linear.

Conservative Systems. Suppose that each configuration of a mechanical system is uniquely determined by a point $q = (q_1, \dots, q_n)$ in an n -dimensional space. If q_1, \dots, q_n can vary independently and arbitrarily, they are called generalized coordinates, and n a number of degrees of freedom. Motion of the system is described by a function $q(t)$. We denote by $\dot{q} = (\dot{q}_1, \dots, \dot{q}_n)$ the corresponding generalized velocities. Hamilton's variational principle states that among all admissible motions of the conservative system satisfying the initial and end conditions

$$q(t_0) = \hat{q}_0, \quad q(t_1) = \hat{q}_1,$$

the true motion is the extremal of the action functional

$$I[q(t)] = \int_{t_0}^{t_1} L(q, \dot{q}) dt.$$

Let us derive the equations of motion from Hamilton's variational principle. To this end we calculate the variation of the action functional (see also [17])

$$\delta I = \int_{t_0}^{t_1} \sum_{j=1}^n \left(\frac{\partial L}{\partial q_j} \delta q_j + \frac{\partial L}{\partial \dot{q}_j} \delta \dot{q}_j \right) dt.$$

Integrating the second term by parts and taking into account that $\delta q_j(t_0) = \delta q_j(t_1) = 0$ due to the initial and end conditions, we get

$$\delta I = \int_{t_0}^{t_1} \sum_{j=1}^n \left(\frac{\partial L}{\partial q_j} - \frac{d}{dt} \frac{\partial L}{\partial \dot{q}_j} \right) \delta q_j dt = 0. \quad (2.26)$$

Since the variations δq_j can be chosen independently and arbitrarily inside the interval (t_0, t_1) , (2.26) implies Lagrange's equations

$$\frac{d}{dt} \frac{\partial L}{\partial \dot{q}_j} - \frac{\partial L}{\partial q_j} = 0, \quad j = 1, \dots, n. \quad (2.27)$$

For any conservative mechanical system the Lagrange function equals

$$L(q, \dot{q}) = K(q, \dot{q}) - U(q),$$

where $K(q, \dot{q})$ is the kinetic energy and $U(q)$ the potential energy. The kinetic energy $K(q, \dot{q})$ is assumed to be a positive definite quadratic form³ with respect to \dot{q}

$$K(q, \dot{q}) = \frac{1}{2} \sum_{j,k=1}^n m_{jk}(q) \dot{q}_j \dot{q}_k.$$

Thus,

$$\sum_{j=1}^n \frac{\partial K}{\partial \dot{q}_j} \dot{q}_j = 2K(q, \dot{q}).$$

Any function possessing this property is called homogeneous function of order two with respect to \dot{q} . We want to show now that the conservation of energy follows from Lagrange's equations (2.27). Indeed, multiplying (2.27) by \dot{q}_j and summing up over j from 1 to n , we obtain

$$\sum_{j=1}^n \left(\frac{d}{dt} \frac{\partial L}{\partial \dot{q}_j} \dot{q}_j - \frac{\partial L}{\partial q_j} \dot{q}_j \right) = 0.$$

Using the product and chain rules of differentiation, we get

$$\sum_{j=1}^n \frac{d}{dt} \left(\frac{\partial L}{\partial \dot{q}_j} \dot{q}_j \right) - \sum_{j=1}^n \left(\frac{\partial L}{\partial \dot{q}_j} \ddot{q}_j + \frac{\partial L}{\partial q_j} \dot{q}_j \right) = \frac{d}{dt} \left(\sum_{j=1}^n \frac{\partial L}{\partial \dot{q}_j} \dot{q}_j - L \right) = 0. \quad (2.28)$$

Taking into account the property of K , we see that the expression in parentheses is equal to $2K - L = K + U$. Thus, the total energy $E = K + U = E_0$ is conserved. Alternatively, the conservation of energy can also be obtained directly from (2.26) by replacing the variations δq_j with the real velocities \dot{q}_j . Indeed, the same procedure transforms (2.26) to

$$\int_{t_0}^{t_1} \frac{d}{dt} (K + U) dt = 0 \quad \Rightarrow \quad K + U = E_0.$$

³ In some cases rearrangement of terms between the kinetic and potential energies is required to achieve this property (see exercise 5.1).

Assume that $U(q)$ has a local minimum at some point q_0 corresponding to a stable equilibrium state and consider small vibrations of our mechanical system about this stable equilibrium state. For small q we may expand $U(q)$ and $K(q, \dot{q})$ in Taylor's series with respect to q near q_0 to get

$$U(q) = U(q_0) + \frac{1}{2} \sum_{j,k=1}^n \left. \frac{\partial^2 U}{\partial q_j \partial q_k} \right|_{q_0} q_j q_k + \dots,$$

$$K(q, \dot{q}) = K(q_0, \dot{q}) + \dots = \frac{1}{2} \sum_{j,k=1}^n m_{jk}(q_0) \dot{q}_j \dot{q}_k + \dots$$

Due to the smallness of q_j and \dot{q}_j , we keep only the quadratic terms in these series. Thus, neglecting the unessential constant $U(q_0)$ in the potential energy, we may present both kinetic and potential energies as follows

$$K(\dot{q}) = \frac{1}{2} \sum_{j,k=1}^n m_{jk} \dot{q}_j \dot{q}_k, \quad U(q) = \frac{1}{2} \sum_{j,k=1}^n k_{jk} q_j q_k. \quad (2.29)$$

Thus, for small vibrations near the stable equilibrium state the kinetic energy $K(\dot{q})$ and the potential energy $U(q)$ are the quadratic forms with respect to \dot{q} and q , respectively. We call the matrix \mathbf{M} with the elements m_{jk} mass matrix, while \mathbf{K} , with the elements k_{jk} , stiffness matrix. Both matrices are symmetric and positive definite. The positive definiteness of \mathbf{K} is due to the fact that $U(q)$ has a local minimum at q_0 . Lagrange's equations of small vibrations near the equilibrium state become linear equations

$$\sum_{k=1}^n (m_{jk} \ddot{q}_k + k_{jk} q_k) = 0, \quad j = 1, \dots, n.$$

Let \mathbf{q} be the column vector $\mathbf{q} = (q_1, \dots, q_n)^T$. We may present these equations also in the matrix form as follows

$$\mathbf{M}\ddot{\mathbf{q}} + \mathbf{K}\mathbf{q} = \mathbf{0}.$$

Dissipative Systems. In this case the following variational principle holds true: among all admissible motions of a dissipative system constrained by the initial and end conditions

$$q(t_0) = \hat{q}_0, \quad q(t_1) = \hat{q}_1,$$

the true motion satisfies the variational equation⁴

$$\delta \int_{t_0}^{t_1} L(q, \dot{q}) dt - \int_{t_0}^{t_1} \sum_{j=1}^n \frac{\partial D}{\partial \dot{q}_j} \delta q_j dt = 0. \quad (2.30)$$

⁴ See page 10, *loc. cit.*

Here $D(q, \dot{q})$ is the dissipation function introduced first by Rayleigh [45]. Calculating the variation of the first term of (2.30) in exactly the same manner as in the previous case leads to

$$\int_{t_0}^{t_1} \sum_{j=1}^n \left(\frac{\partial L}{\partial q_j} - \frac{d}{dt} \frac{\partial L}{\partial \dot{q}_j} \right) \delta q_j dt - \int_{t_0}^{t_1} \sum_{j=1}^n \frac{\partial D}{\partial \dot{q}_j} \delta q_j dt = 0.$$

Due to the arbitrariness of δq_j inside the time interval (t_0, t_1) the following equations are obtained

$$\frac{d}{dt} \frac{\partial L}{\partial \dot{q}_j} - \frac{\partial L}{\partial q_j} + \frac{\partial D}{\partial \dot{q}_j} = 0, \quad j = 1, \dots, n. \quad (2.31)$$

For dissipative systems vibrating near the equilibrium states the dissipation function can be assumed as a non-negative definite quadratic form with respect to \dot{q}

$$D(q, \dot{q}) = \frac{1}{2} \sum_{j,k=1}^n c_{jk}(q) \dot{q}_j \dot{q}_k \geq 0 \quad \text{for all } \dot{q},$$

where c_{jk} is a symmetric matrix (Onsager's principle [38]). In this case $D(q, \dot{q})$ is also the homogeneous function of order two with respect to \dot{q} . We now derive the balance equation of energy from modified Lagrange's equations (2.31). Multiplying (2.31) by \dot{q}_j and summing up over j from 1 to n , we obtain

$$\sum_{j=1}^n \left(\frac{d}{dt} \frac{\partial K}{\partial \dot{q}_j} \dot{q}_j - \frac{\partial L}{\partial q_j} \dot{q}_j \right) = - \sum_{j=1}^n \frac{\partial D}{\partial \dot{q}_j} \dot{q}_j.$$

The expression on the right-hand side is nothing else but the power of the damping forces. Making the same observations as in the previous case and using the property of D we get

$$\frac{d}{dt}(K + U) = -2D(q, \dot{q}).$$

Thus, the rate of change of energy is equal to $-2D(q, \dot{q})$. Since $-2D(q, \dot{q})$ is the energy loss per unit time, we call $2D(q, \dot{q})$ energy dissipation rate. We see that the energy dissipation rate is non-negative.⁵ Integrating this equation from t_0 to t , we find the energy change at time t

$$K + U - E_0 = -2 \int_{t_0}^t D(q(s), \dot{q}(s)) ds = -E_d(t), \quad (2.32)$$

where E_0 is the total energy at $t = t_0$ and $E_d(t)$ the amount of energy dissipated by the dampers at time t . Note that this balance equation can also be directly obtained from the variational equation (2.30) by replacing the variations δq_j by the real velocities \dot{q}_j .

⁵ It is interesting to mention that, if the system does not vibrate about the equilibrium states, this property is no longer valid (see Section 5.3).

For small vibrations near the stable equilibrium state q_0 we may, to the first approximation, assume the kinetic and potential energies in the form (2.29). The dissipation function can also be expanded in Taylor's series near this state. Neglecting all small terms of higher orders we write

$$D(q, \dot{q}) = D(q_0, \dot{q}) = \frac{1}{2} \sum_{j,k=1}^n c_{jk}(q_0) \dot{q}_j \dot{q}_k,$$

where the matrix \mathbf{C} with the elements $c_{jk}(q_0)$ is called the damping matrix. Modified Lagrange's equations of small vibrations near the equilibrium state take the form

$$\sum_{k=1}^n (m_{jk} \ddot{q}_k + c_{jk} \dot{q}_k + k_{jk} q_k) = 0, \quad j = 1, \dots, n.$$

We may present these equations also in the matrix form as follows

$$\mathbf{M}\ddot{\mathbf{q}} + \mathbf{C}\dot{\mathbf{q}} + \mathbf{K}\mathbf{q} = \mathbf{0}.$$

Systems with External Forces. If there are external generalized forces $f_j(t)$ acting on q_j , we must add to the left-hand side of variational equation (2.30) the virtual work done by the external forces. The variational principle becomes: among all admissible motions constrained by the initial and end conditions

$$q(t_0) = \hat{q}_0, \quad q(t_1) = \hat{q}_1,$$

the true motion satisfies the variational equation

$$\delta \int_{t_0}^{t_1} L(q, \dot{q}) dt - \int_{t_0}^{t_1} \sum_{j=1}^n \frac{\partial D}{\partial \dot{q}_j} \delta q_j dt + \delta A = 0, \quad (2.33)$$

where δA is the virtual work done by the generalized forces $f_j(t)$

$$\delta A = \int_{t_0}^{t_1} \sum_{j=1}^n f_j(t) \delta q_j dt.$$

We can also take the Lagrange function in the form

$$L(q, \dot{q}, t) = K(q, \dot{q}) - U(q) + \sum_{j=1}^n f_j(t) q_j,$$

and reformulate the variational equation as follows

$$\delta \int_{t_0}^{t_1} L(q, \dot{q}, t) dt - \int_{t_0}^{t_1} \sum_{j=1}^n \frac{\partial D}{\partial \dot{q}_j} \delta q_j dt = 0.$$

Since time enters the Lagrange function explicitly, such systems are called non-autonomous.

From (2.33) one can derive modified Lagrange's equations

$$\frac{d}{dt} \frac{\partial L}{\partial \dot{q}_j} - \frac{\partial L}{\partial q_j} + \frac{\partial D}{\partial \dot{q}_j} = f_j(t), \quad j = 1, \dots, n.$$

Replacing in the variational equation (2.33) the variations δq_i by the real velocities \dot{q}_i and repeating the transformations as in the previous paragraph, we obtain the balance of energy in the form

$$K + U - E_0 = -2 \int_{t_0}^t D(q(s), \dot{q}(s)) ds + \int_{t_0}^t \sum_{j=1}^n f_j(s) \dot{q}_j(s) ds = -E_d(t) + W(t), \quad (2.34)$$

where E_0 is the total energy at $t = t_0$. The last term $W(t)$ is the work done by the external forces which is stored in the energy of the system except that part $E_d(t)$ dissipated by the dampers.

For small vibrations near the stable equilibrium state Lagrange's equations can be presented in the matrix form as follows

$$\mathbf{M}\ddot{\mathbf{q}} + \mathbf{C}\dot{\mathbf{q}} + \mathbf{K}\mathbf{q} = \mathbf{f}(t),$$

with $\mathbf{f}(t) = (f_1(t), \dots, f_n(t))^T$ being the column vector of external forces.

2.5 Oscillators with n Degrees of Freedom

We present in this Section the method of solution and some general properties for systems with n degrees of freedom, where n is an arbitrary natural number.

Conservative Oscillators. The motion is described by the equation

$$\mathbf{M}\ddot{\mathbf{q}} + \mathbf{K}\mathbf{q} = \mathbf{0}, \quad (2.35)$$

where \mathbf{M} and \mathbf{K} are symmetric and positive definite matrices. We have to find the solution of this equation satisfying the initial conditions

$$\mathbf{q}(0) = \mathbf{q}_0, \quad \dot{\mathbf{q}}(0) = \mathbf{v}_0. \quad (2.36)$$

Solution. Let us first seek a particular solution of (2.35) in the form

$$\mathbf{q} = \hat{\mathbf{q}} e^{st},$$

where $\hat{\mathbf{q}}$ is a constant vector. Substituting this Ansatz into (2.35) and eliminating the non-vanishing factor e^{st} , we reduce the latter to the eigenvalue problem

$$(\mathbf{M}s^2 + \mathbf{K})\hat{\mathbf{q}} = \mathbf{0}. \quad (2.37)$$

The related characteristic equation

$$\det(\mathbf{M}s^2 + \mathbf{K}) = 0$$

is the algebraic equation of order n with respect to s^2 yielding n eigenvalues. It is easy to see that all eigenvalues are real and negative. Indeed, if s_j^2 is an eigenvalue and \mathbf{q}_j a corresponding eigenvector, then, multiplying (2.37) by the vector \mathbf{q}_j , we have

$$\mathbf{q}_j \cdot \mathbf{M}\mathbf{q}_j s_j^2 + \mathbf{q}_j \cdot \mathbf{K}\mathbf{q}_j = 0.$$

Thus,

$$s_j^2 = -\frac{\mathbf{q}_j \cdot \mathbf{K}\mathbf{q}_j}{\mathbf{q}_j \cdot \mathbf{M}\mathbf{q}_j} < 0, \quad (2.38)$$

since both the numerator and denominator are positive. Therefore the roots of the characteristic equation are imaginary numbers given by

$$s_j = \pm i\omega_j, \quad j = 1, \dots, n,$$

where ω_j are called eigenfrequencies of vibrations. We will order them in such a way that

$$0 < \omega_1 \leq \omega_2 \leq \dots \leq \omega_n.$$

Let \mathbf{q}_j be the eigenvector (the solution of (2.37)) corresponding to the j -th eigenvalue. It is defined uniquely up to a constant factor. We can fix this constant by some normalization condition. As such we choose

$$\mathbf{q}_j \cdot \mathbf{M}\mathbf{q}_j = 1.$$

Note that two eigenvectors \mathbf{q}_j and \mathbf{q}_k corresponding to two different eigenvalues s_j^2 and s_k^2 are orthogonal in the sense that

$$\mathbf{q}_j \cdot \mathbf{M}\mathbf{q}_k = 0.$$

To show this we multiply equation (2.37) for $s = s_j$ by \mathbf{q}_k to get

$$\mathbf{q}_k \cdot \mathbf{M}\mathbf{q}_j s_j^2 = -\mathbf{q}_k \cdot \mathbf{K}\mathbf{q}_j. \quad (2.39)$$

Similar procedure applied to the equation for $s = s_k$ gives

$$\mathbf{q}_j \cdot \mathbf{M}\mathbf{q}_k s_k^2 = -\mathbf{q}_j \cdot \mathbf{K}\mathbf{q}_k.$$

Subtracting these equations from each other and taking into account that \mathbf{M} and \mathbf{K} are symmetric, we obtain

$$(s_j^2 - s_k^2)\mathbf{q}_j \cdot \mathbf{M}\mathbf{q}_k = 0,$$

which implies the orthogonality. The orthogonality and normalization conditions can be presented in one equation

$$\mathbf{q}_j \cdot \mathbf{M}\mathbf{q}_k = \delta_{jk} = \begin{cases} 1 & \text{if } j = k, \\ 0 & \text{otherwise.} \end{cases} \quad (2.40)$$

If there is a multiple eigenvalue, then the corresponding eigenvectors span a subspace of dimension equal to the multiplicity of the eigenvalue. Therefore, it is always possible to find a set of vectors in this subspace satisfying the orthogonality and normalization conditions.

Since $\mathbf{q}_j e^{i\omega_j t}$ are the solutions of (2.35) which is the differential equation with real matrices, their real and imaginary parts

$$\mathbf{q}_j \cos \omega_j t \quad \text{and} \quad \mathbf{q}_j \sin \omega_j t$$

must also satisfy this equation. The general solution can now be constructed as the linear superposition

$$\mathbf{q}(t) = \sum_{j=1}^n \mathbf{q}_j (A_j \cos \omega_j t + B_j \sin \omega_j t).$$

The unknown coefficients A_j and B_j must be found from the initial conditions (2.36) giving

$$\sum_{j=1}^n A_j \mathbf{q}_j = \mathbf{q}_0, \quad \sum_{j=1}^n B_j \omega_j \mathbf{q}_j = \mathbf{v}_0.$$

Multiplying these equations from the left by \mathbf{M} and then by \mathbf{q}_i and making use of the orthogonality and normalization conditions, we obtain from here

$$A_i = \mathbf{q}_i \cdot \mathbf{M}\mathbf{q}_0, \quad B_i = \frac{1}{\omega_i} \mathbf{q}_i \cdot \mathbf{M}\mathbf{v}_0, \quad i = 1, \dots, n.$$

Alternatively, we can present the solution in the form

$$\mathbf{q}(t) = \sum_{j=1}^n \mathbf{q}_j a_j \cos(\omega_j t - \phi_j),$$

where

$$a_j = \sqrt{A_j^2 + B_j^2}, \quad \tan \phi_j = \frac{B_j}{A_j}, \quad j = 1, \dots, n.$$

Normal modes and coordinates. The above solution is the sum of n harmonic motions, so it is in general non-periodic if the frequency ratios are not rational numbers. However, for the initial conditions of the special form

$$\mathbf{q}_0 = q_0 \mathbf{q}_j, \quad \mathbf{v}_0 = v_0 \mathbf{q}_j,$$

the motion is purely harmonic with the frequency ω_j . We call such motion normal mode.

The question now arises: can we find the coordinates in which the normal modes become independent? The similar consideration as that provided in example 2.2 shows that this is possible if the kinetic and potential energies of the system, in terms of the new coordinates ξ_j , take the form

$$K(\dot{\xi}) = \frac{1}{2} \sum_{j=1}^n \dot{\xi}_j^2, \quad U(\xi) = \frac{1}{2} \sum_{j=1}^n \omega_j^2 \xi_j^2.$$

Thus, the problem reduces to finding a linear transformation which simultaneously diagonalizes two quadratic forms. As we know from linear algebra [37], the required transformation is given by

$$\mathbf{q} = \mathbf{Q}\xi,$$

with

$$\mathbf{Q} = (\mathbf{q}_1 \mathbf{q}_2 \dots \mathbf{q}_n)$$

being the $n \times n$ matrix, whose j -th column is the j -th eigenvector found above. We shall call \mathbf{Q} modal matrix. In terms of the vector of normal coordinates ξ we have

$$\begin{aligned} K(\dot{\xi}) &= \frac{1}{2} \dot{\mathbf{q}} \cdot \mathbf{M} \dot{\mathbf{q}} = \frac{1}{2} \dot{\xi} \cdot \mathbf{Q}^T \mathbf{M} \mathbf{Q} \dot{\xi} = \frac{1}{2} \dot{\xi} \cdot \dot{\xi}, \\ U(\xi) &= \frac{1}{2} \mathbf{q} \cdot \mathbf{K} \mathbf{q} = \frac{1}{2} \xi \cdot \mathbf{Q}^T \mathbf{K} \mathbf{Q} \xi = \frac{1}{2} \xi \cdot \mathbf{\Omega}^2 \xi, \end{aligned}$$

where \mathbf{Q}^T denotes the transpose of \mathbf{Q} , and $\mathbf{\Omega}^2$ is the diagonal matrix with the elements ω_j^2 on the diagonal. The last identities in these formulas are obtained by the orthogonality conditions (2.39) and (2.40). So, the corresponding Lagrange function describes the motion of n uncoupled single oscillators with the frequencies ω_j , $j = 1, \dots, n$.

Extremal properties. If ω is an eigenfrequency and $\hat{\mathbf{q}}$ a corresponding eigenvector, then it follows from (2.38) that

$$\omega^2 = \frac{\hat{\mathbf{q}} \cdot \mathbf{K} \hat{\mathbf{q}}}{\hat{\mathbf{q}} \cdot \mathbf{M} \hat{\mathbf{q}}} = r(\hat{\mathbf{q}}).$$

The right-hand side of this equation is called Rayleigh's quotient [45]. It turns out that the following extremal properties hold true.

1. The square of smallest eigenfrequency ω_1^2 is the minimum of $r(\mathbf{q})$ among all $\mathbf{q} \neq 0$. The easiest way to prove this is to rewrite Rayleigh's quotient in terms of the vector of normal coordinates

$$r(\xi) = \frac{\omega_1^2 \xi_1^2 + \dots + \omega_n^2 \xi_n^2}{\xi_1^2 + \dots + \xi_n^2}.$$

Since $\omega_n \geq \dots \geq \omega_1$, Rayleigh's quotient is always larger than or equal to ω_1^2 . From the other side $r(\xi) = \omega_1^2$ if $\xi_1 = 1$ and $\xi_2 = \dots = \xi_n = 0$. So the statement is proved.

2. The square of j -th eigenfrequency ω_j^2 is equal to the minimum of Rayleigh's quotient

$$\omega_j^2 = \min_{\mathbf{q}} r(\mathbf{q})$$

among all $\mathbf{q} \neq 0$ satisfying $j - 1$ constraints

$$\mathbf{q}_1 \cdot \mathbf{M}\mathbf{q} = 0, \dots, \mathbf{q}_{j-1} \cdot \mathbf{M}\mathbf{q} = 0.$$

Indeed, in terms of the normal coordinates the above constraints become

$$\xi_1 = \dots = \xi_{j-1} = 0.$$

Thus, Rayleigh's quotient under these constraints reduces to

$$r(\boldsymbol{\xi}) = \frac{\omega_j^2 \xi_j^2 + \dots + \omega_n^2 \xi_n^2}{\xi_j^2 + \dots + \xi_n^2},$$

and the proof can be provided in a similar manner.

The extremal properties of Rayleigh's quotient are quite useful in approximate calculations of the eigenfrequencies [45].

Damped Oscillators. The motion is described by the equation

$$\mathbf{M}\ddot{\mathbf{q}} + \mathbf{C}\dot{\mathbf{q}} + \mathbf{K}\mathbf{q} = \mathbf{0}, \quad (2.41)$$

subject to the initial conditions

$$\mathbf{q}(0) = \mathbf{q}_0, \quad \dot{\mathbf{q}}(0) = \mathbf{v}_0, \quad (2.42)$$

where \mathbf{M} and \mathbf{K} are symmetric and positive definite matrices, while \mathbf{C} is symmetric and non-negative definite.

Solution. A particular solution of (2.41) is sought in the form

$$\mathbf{q} = \hat{\mathbf{q}}e^{st},$$

where $\hat{\mathbf{q}}$ is a constant vector. Equation (2.41) reduces then to the algebraic equation

$$(\mathbf{M}s^2 + \mathbf{C}s + \mathbf{K})\hat{\mathbf{q}} = \mathbf{0}. \quad (2.43)$$

Non-trivial solutions of (2.43) exist if

$$\det(\mathbf{M}s^2 + \mathbf{C}s + \mathbf{K}) = 0.$$

This is the algebraic equation of order $2n$ with respect to s having $2n$ roots. Since the matrices \mathbf{M} , \mathbf{C} , and \mathbf{K} are real, the complex roots must occur in pairs of complex conjugates. Moreover, if s_j^* is the complex conjugate root with respect to s_j , then the corresponding eigenvector \mathbf{q}_j^* must be complex conjugate to the eigenvector \mathbf{q}_j

of s_j . It turns out that all roots of the characteristic equation have non-positive real parts. To show this one can apply the Routh-Hurwitz criterion although the proof is not elementary. The more elementary proof is based on the balance of energy (2.32) for dissipative systems. To this end let us assume that there is a root of the characteristic equation with the positive real part $s = \delta + i\omega$, where $\delta > 0$. Then a free vibration of the form

$$\mathbf{q} = e^{\delta t} \operatorname{Re}(\hat{\mathbf{q}} e^{i\omega t})$$

exists, with $\hat{\mathbf{q}}$ being the eigenvector corresponding to s . Substituting this particular solution into the energy balance equation (2.32) and using the positive definiteness of the dissipation function, we see that the amount of energy dissipation goes to $-\infty$ as t tends to infinity, what contradicts the positiveness of the total energy.

The general solution of (2.41) is given in the form

$$\mathbf{q} = \sum_{j=1}^{2n} A_j \mathbf{q}_j e^{s_j t}.$$

Using the initial conditions (2.42), we obtain the system of $2n$ linear equations

$$\sum_{j=1}^{2n} A_j \mathbf{q}_j = \mathbf{q}_0, \quad \sum_{j=1}^{2n} A_j s_j \mathbf{q}_j = \mathbf{v}_0,$$

for the determination of $2n$ coefficients A_j .

Modal decomposition. The coupled oscillators with n degrees of freedom and with the proportional damping can be reduced to n uncoupled damped oscillators. To show this let us introduce the vector of normal coordinates $\boldsymbol{\xi}$ such that $\mathbf{q} = \mathbf{Q}\boldsymbol{\xi}$, with \mathbf{Q} being the modal matrix, into the equation of motion (2.41). Multiplying this equation from the left by \mathbf{Q}^T , we obtain

$$\mathbf{Q}^T \mathbf{M} \mathbf{Q} \ddot{\boldsymbol{\xi}} + \mathbf{Q}^T \mathbf{C} \mathbf{Q} \dot{\boldsymbol{\xi}} + \mathbf{Q}^T \mathbf{K} \mathbf{Q} \boldsymbol{\xi} = \mathbf{0}.$$

The modal matrix \mathbf{Q} diagonalizes simultaneously \mathbf{M} and \mathbf{K} , so

$$\mathbf{Q}^T \mathbf{M} \mathbf{Q} = \mathbf{I}, \quad \mathbf{Q}^T \mathbf{K} \mathbf{Q} = \boldsymbol{\Omega}^2 = \operatorname{diag}(\omega_j^2),$$

where \mathbf{I} is the identity matrix and $\boldsymbol{\Omega}^2$ the diagonal matrix with the elements ω_j^2 . Because of the proportional damping $\mathbf{C} = \alpha \mathbf{M} + \beta \mathbf{K}$ we have

$$\boldsymbol{\Delta} = \mathbf{Q}^T \mathbf{C} \mathbf{Q} = \mathbf{Q}^T (\alpha \mathbf{M} + \beta \mathbf{K}) \mathbf{Q} = \alpha \mathbf{I} + \beta \boldsymbol{\Omega}^2 = \operatorname{diag}(2\delta_j \omega_j),$$

where $\delta_j \omega_j = (\alpha + \beta \omega_j^2)/2$ are the decay rates. Thus, the damping matrix $\boldsymbol{\Delta}$ becomes also diagonal in terms of the normal coordinates. The equation of motion is decomposed into n uncoupled equations

$$\ddot{\xi}_j + 2\delta_j \omega_j \dot{\xi}_j + \omega_j^2 \xi_j = 0, \quad j = 1, \dots, n,$$

which can be solved by the method discussed in Section 1.2.

Alternatively, we can also realize the modal decomposition by diagonalizing the kinetic and potential energies together with the dissipation function as the quadratic forms.

Forced Oscillators. The motion is described by the equation

$$\mathbf{M}\ddot{\mathbf{q}} + \mathbf{C}\dot{\mathbf{q}} + \mathbf{K}\mathbf{q} = \mathbf{f}(t). \quad (2.44)$$

Since this equation is linear, its solution is the sum of any particular solution and the general solution of the homogeneous equation which has been found previously. Thus, the problem reduces to finding any particular solution of (2.44). Besides, if the damping is permeating, then all solutions of the homogeneous equation decay with time, so only the particular solution of (2.44) persists at large time.

Harmonic excitations. For the harmonic excitations of the form $\mathbf{f}(t) = \hat{\mathbf{f}}\cos\omega t$ which is the real part of $\hat{\mathbf{f}}e^{i\omega t}$ we consider the auxiliary equation

$$\mathbf{M}\dot{\mathbf{z}} + \mathbf{C}\mathbf{z} + \mathbf{K}\mathbf{z} = \hat{\mathbf{f}}e^{i\omega t},$$

where $\mathbf{z}(t)$ may be complex-valued. We look for the solution of the form $\mathbf{z}(t) = \hat{\mathbf{z}}e^{i\omega t}$. Substituting this into the above equation and eliminating the factor $e^{i\omega t}$, we obtain

$$(-\omega^2\mathbf{M} + i\omega\mathbf{C} + \mathbf{K})\hat{\mathbf{z}} = \hat{\mathbf{f}}.$$

Provided the matrix on the left-hand side has an inverse, this equation yields

$$\hat{\mathbf{z}} = (-\omega^2\mathbf{M} + i\omega\mathbf{C} + \mathbf{K})^{-1}\hat{\mathbf{f}} = \mathbf{G}(\omega)\hat{\mathbf{f}}.$$

Matrix $\mathbf{G}(\omega)$ is called a transmittance matrix of the system. The particular solution of (2.44) is the real part of $\mathbf{z}(t)$, so

$$\mathbf{q}(t) = \text{Re}(\mathbf{G}(\omega)\hat{\mathbf{f}}e^{i\omega t}).$$

The analysis of forced vibrations simplifies considerably for the conservative oscillators with $\mathbf{C} = \mathbf{0}$. In this case the solution also has the form $\mathbf{q}(t) = \hat{\mathbf{q}}\cos\omega t$, where $\hat{\mathbf{q}}$ satisfies the linear equation

$$(-\omega^2\mathbf{M} + \mathbf{K})\hat{\mathbf{q}} = \hat{\mathbf{f}}.$$

If the determinant $\Delta(\omega)$ of $-\omega^2\mathbf{M} + \mathbf{K}$ differs from zero, we use Cramer's rule to present the solution in the form

$$\hat{q}_j = \frac{\Delta_j(\omega)}{\Delta(\omega)}, \quad j = 1, \dots, n, \quad (2.45)$$

where $\Delta_j(\omega)$ is the determinant obtained on replacing the j -th column of Δ by the vector $\hat{\mathbf{f}}$. The following interesting cases may occur:

- a) $\Delta(\omega) = 0, \Delta_j(\omega) \neq 0$: the frequency of excitation coincides with one of the eigenfrequency and the oscillators are in resonance,
 b) $\Delta(\omega) = 0, \Delta_j(\omega) = 0$ for all j so that $\lim_{\tilde{\omega} \rightarrow \omega} \Delta_j(\tilde{\omega})/\Delta(\tilde{\omega}) < \infty$: this situation is classified as pseudo-resonance,
 c) $\Delta(\omega) \neq 0, \Delta_j(\omega) = 0$: the forced vibration corresponding to the j -th degree of freedom is eliminated (anti-resonance).

For the dissipative oscillators with small but finite damping coefficients neither resonance nor anti-resonance occurs. The problem of vibration control reduces then to finding optimal parameters of vibration absorbers to effectively absorb energy of the unwanted forced vibration.

Arbitrary excitations. For forced oscillators with proportional damping the problem can be solved by the modal decomposition as shown in example 2.9. For forced oscillators with non-proportional damping, the Laplace transform should be used instead. Not restricting the generality, we look for the particular solution of (2.44) satisfying the initial conditions

$$\mathbf{q}(0) = \mathbf{0}, \quad \dot{\mathbf{q}}(0) = \mathbf{0}.$$

Applying the Laplace transform to both sides of equation (2.44), we obtain

$$\int_0^{\infty} (\mathbf{M}\ddot{\mathbf{q}} + \mathbf{C}\dot{\mathbf{q}} + \mathbf{K}\mathbf{q})e^{-st} dt = \int_0^{\infty} \mathbf{f}(t)e^{-st} dt.$$

Using the properties of the Laplace transform and the vanishing initial conditions, we reduce this to the algebraic equation

$$(\mathbf{M}s^2 + \mathbf{C}s + \mathbf{K})\mathbf{X}(s) = \mathbf{F}(s),$$

where $\mathbf{X}(s)$ and $\mathbf{F}(s)$ are the Laplace images of $\mathbf{q}(t)$ and $\mathbf{f}(t)$, respectively. This yields

$$\mathbf{X}(s) = (\mathbf{M}s^2 + \mathbf{C}s + \mathbf{K})^{-1}\mathbf{F}(s).$$

Applying the inverse Laplace transform, we get

$$\mathbf{q}(t) = \mathcal{L}^{-1}[\mathbf{X}(s)] = \frac{1}{2\pi i} \int_{\alpha - i\infty}^{\alpha + i\infty} (\mathbf{M}s^2 + \mathbf{C}s + \mathbf{K})^{-1}\mathbf{F}(s)e^{st} ds,$$

where α is any positive number. Since all roots of the characteristic equation lie in the left half-plane or on the imaginary axis, the integrand is an analytic function in the right half-plane of the complex s -plane. Thus, for an arbitrary regular excitation $\mathbf{f}(t)$ which remains finite as t goes to infinity the integral converges. The line of integration ($\alpha - i\infty, \alpha + i\infty$) can be moved arbitrarily in the right half-plane.

Let $\mathbf{x}_{rj}(t)$ be the solution of (2.44) with zero initial condition, where

$$\mathbf{f}(t) = \mathbf{h}_j(t) = (0, \dots, h(t), \dots, 0)^T,$$

$h(t)$ being Heaviside's step function. Thus, $\mathbf{h}_j(t)$ is the column vector whose components are zero except the j -th component which is the Heaviside's step function. The $n \times n$ matrix

$$\mathbf{X}_r(t) = (\mathbf{x}_{r1}(t) \dots \mathbf{x}_{rn}(t)),$$

with j -th column being the vector $\mathbf{x}_{rj}(t)$, is called a unit step response matrix of the system. It is easy to see that

$$(\mathbf{M}s^2 + \mathbf{C}s + \mathbf{K})^{-1} \frac{1}{s} = \mathcal{L}(\mathbf{X}_r(t)).$$

Using the convolution theorem for the Laplace transform, we obtain finally

$$\mathbf{q}(\tau) = \int_0^\tau \mathbf{X}_r(\tau - t) \dot{\mathbf{f}}(t) dt. \quad (2.46)$$

This is generalized Duhamel's formula which solves the problem if the unit step response matrix of the system is known.

Mention that the Laplace transform can also be used to solve the initial value problem similar to that analyzed in Section 1.3.

2.6 Exercises

EXERCISE 2.1. Two point-masses m_1 and m_2 are connected with a fixed support O and with each other by two rigid and massless bars of lengths l_1 and l_2 (see Fig. 2.14). Derive the equations of small vibration of this double pendulum under the action of gravity. Determine the eigenfrequencies of vibrations.

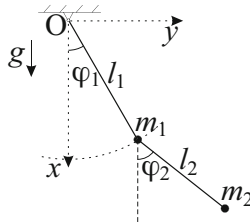

Fig. 2.14 Double pendulum

Solution. This system has two degrees of freedom described by the angles φ_1 and φ_2 . Let us write down the kinetic and potential energies of this double pendulum. For the kinetic energy we have

$$K(\dot{\varphi}) = \frac{1}{2} m_1 v_1^2 + \frac{1}{2} m_2 v_2^2.$$

As the first point-mass m_1 rotates about O with the angular velocity $\dot{\varphi}_1$, the magnitude of its velocity is $v_1 = l_1 \dot{\varphi}_1$. The velocity of m_2 is the superposition of the velocity of m_1 and the relative velocity of m_2 with respect to m_1 , so

$$\mathbf{v}_2 = \mathbf{v}_1 + \mathbf{v}_{21}.$$

Since both angles φ_1 and φ_2 are small, these two vectors are nearly parallel. Taking into account that $v_{21} = l_2 \dot{\varphi}_2$, we can write

$$v_2^2 = v_1^2 + v_{21}^2 + 2\mathbf{v}_1 \cdot \mathbf{v}_{21} \approx l_1^2 \dot{\varphi}_1^2 + l_2^2 \dot{\varphi}_2^2 + 2l_1 l_2 \dot{\varphi}_1 \dot{\varphi}_2.$$

Thus, the kinetic energy is equal to

$$K(\dot{\varphi}) = \frac{1}{2}(m_1 + m_2)l_1^2 \dot{\varphi}_1^2 + \frac{1}{2}m_2 l_2^2 \dot{\varphi}_2^2 + m_2 l_1 l_2 \dot{\varphi}_1 \dot{\varphi}_2.$$

Let us choose the zero level of the potential energy at $x = 0$. Then the potential energy of the point-masses in the gravitational field is given by

$$U(\varphi) = -m_1 g x_1 - m_2 g x_2 = -m_1 g l_1 \cos \varphi_1 - m_2 g (l_1 \cos \varphi_1 + l_2 \cos \varphi_2).$$

For small angles φ_1 and φ_2 we may replace $\cos \varphi_j \approx 1 - \varphi_j^2/2$, so up to an unessential constant,

$$U(\varphi) = \frac{1}{2}m_1 g l_1 \varphi_1^2 + \frac{1}{2}m_2 g l_1 \varphi_1^2 + \frac{1}{2}m_2 g l_2 \varphi_2^2.$$

Thus, the Lagrange function reads

$$L = \frac{1}{2}(m_1 + m_2)l_1^2 \dot{\varphi}_1^2 + \frac{1}{2}m_2 l_2^2 \dot{\varphi}_2^2 + m_2 l_1 l_2 \dot{\varphi}_1 \dot{\varphi}_2 - \frac{1}{2}(m_1 + m_2)g l_1 \varphi_1^2 - \frac{1}{2}m_2 g l_2 \varphi_2^2.$$

From Lagrange's equations

$$\frac{d}{dt} \frac{\partial L}{\partial \dot{\varphi}_j} - \frac{\partial L}{\partial \varphi_j} = 0, \quad j = 1, 2,$$

we derive the equations of motion

$$\begin{aligned} \frac{d}{dt} ((m_1 + m_2)l_1^2 \dot{\varphi}_1 + m_2 l_1 l_2 \dot{\varphi}_2) + (m_1 + m_2)g l_1 \varphi_1 &= 0, \\ \frac{d}{dt} (m_2 l_2^2 \dot{\varphi}_2 + m_2 l_1 l_2 \dot{\varphi}_1) + m_2 g l_2 \varphi_2 &= 0. \end{aligned}$$

Dividing the first equation by l_1 and the second one by $m_2 l_2$, we reduce this system to

$$\begin{aligned} (m_1 + m_2)l_1 \ddot{\varphi}_1 + m_2 l_2 \ddot{\varphi}_2 + (m_1 + m_2)g \varphi_1 &= 0, \\ l_1 \ddot{\varphi}_1 + l_2 \ddot{\varphi}_2 + g \varphi_2 &= 0. \end{aligned}$$

To determine the eigenfrequencies of vibrations we seek for the solution in the form

$$\varphi_j = \hat{\varphi}_j e^{i\omega t}.$$

Substituting this into the equations of motion, we get

$$\begin{pmatrix} (m_1 + m_2)(g - l_1\omega^2) & -m_2 l_2 \omega^2 \\ -l_1 \omega^2 & g - l_2 \omega^2 \end{pmatrix} \begin{pmatrix} \hat{\varphi}_1 \\ \hat{\varphi}_2 \end{pmatrix} = \begin{pmatrix} 0 \\ 0 \end{pmatrix}.$$

Non-trivial solutions of this equation exist if its determinant vanishes

$$\begin{vmatrix} (m_1 + m_2)(g - l_1\omega^2) & -m_2 l_2 \omega^2 \\ -l_1 \omega^2 & g - l_2 \omega^2 \end{vmatrix} = 0.$$

Computing the determinant, we get the following characteristic equation

$$m_1 l_1 l_2 \omega^4 - (m_1 + m_2)g(l_1 + l_2)\omega^2 + (m_1 + m_2)g^2 = 0.$$

Solving this quadratic equation (with respect to ω^2), we obtain two roots $\omega_{1,2}^2$ given by

$$\frac{g}{2m_1 l_1 l_2} \left[(m_1 + m_2)(l_1 + l_2) \mp \sqrt{(m_1 + m_2)[(m_1 + m_2)(l_1 + l_2)^2 - 4m_1 l_1 l_2]} \right].$$

EXERCISE 2.2. A body of mass m is connected with the wall through a spring of stiffness k and with a bar of length l and equal mass m which rotates in the plane about O (see Fig. 2.15). Derive the equations of small vibration of this system. Determine the eigenfrequencies of vibrations.

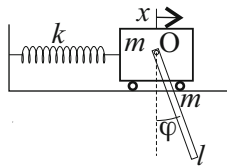

Fig. 2.15 Body connected with spring and bar

Solution. Let $q = (x, \varphi)$ be the generalized coordinates and S be the center of mass of the bar. We write down the kinetic energy of this system

$$K(\dot{q}) = \frac{1}{2}m\dot{x}^2 + \frac{1}{2}m v_S^2 + \frac{1}{2}J_S \dot{\varphi}^2,$$

where the last two terms represent the kinetic energy of the bar, with v_S being the velocity of the center of mass and $J_S = ml^2/12$ the moment of inertia of the bar about S. For small angle $\varphi \ll 1$

$$v_S = \dot{x} + \frac{l}{2}\dot{\phi}.$$

So, the kinetic energy of this system reads

$$K(\dot{q}) = \frac{1}{2}m\dot{x}^2 + \frac{1}{2}m\left(\dot{x} + \frac{l}{2}\dot{\phi}\right)^2 + \frac{1}{24}ml^2\dot{\phi}^2.$$

Concerning the potential energy, we have for small angle

$$U(q) = \frac{1}{2}kx^2 + mg\frac{l}{2}(1 - \cos\phi) \approx \frac{1}{2}kx^2 + mg\frac{l}{4}\phi^2.$$

Thus,

$$L(q, \dot{q}) = \frac{1}{2}m\dot{x}^2 + \frac{1}{2}m\left(\dot{x} + \frac{l}{2}\dot{\phi}\right)^2 + \frac{1}{24}ml^2\dot{\phi}^2 - \frac{1}{2}kx^2 - mg\frac{l}{4}\phi^2.$$

From Lagrange's equations

$$\frac{d}{dt} \frac{\partial L}{\partial \dot{q}_j} - \frac{\partial L}{\partial q_j} = 0, \quad j = 1, 2,$$

we derive the equations of motion

$$\begin{aligned} m\ddot{x} + m\left(\ddot{x} + \frac{l}{2}\ddot{\phi}\right) + kx &= 0, \\ m\frac{l}{2}\left(\ddot{x} + \frac{l}{2}\ddot{\phi}\right) + \frac{1}{12}ml^2\ddot{\phi} + \frac{1}{2}mgl\phi &= 0. \end{aligned}$$

These equations can be simplified to

$$\begin{aligned} 2m\ddot{x} + m\frac{l}{2}\ddot{\phi} + kx &= 0, \\ \frac{1}{3}ml^2\ddot{\phi} + m\frac{l}{2}\ddot{x} + \frac{1}{2}mgl\phi &= 0. \end{aligned}$$

Dividing the first equation by $2m$ and the second one by $ml^2/3$, respectively, we rewrite them in the form

$$\begin{aligned} \ddot{x} + \frac{l}{4}\ddot{\phi} + \omega_x^2 x &= 0, \\ \frac{3}{2l}\ddot{x} + \ddot{\phi} + \omega_\phi^2 \phi &= 0, \end{aligned}$$

where

$$\omega_x^2 = \frac{k}{2m}, \quad \omega_\phi^2 = \frac{3g}{2l}.$$

To determine the eigenfrequencies of vibrations we seek for the solution in the form

$$\begin{pmatrix} x \\ \varphi \end{pmatrix} = \begin{pmatrix} \hat{x} \\ \hat{\varphi} \end{pmatrix} e^{i\omega t}.$$

Substituting this into the equations of motion, we get

$$\begin{pmatrix} -\omega^2 + \omega_x^2 & -\frac{l}{4}\omega^2 \\ -\frac{3}{2l}\omega^2 & -\omega^2 + \omega_\varphi^2 \end{pmatrix} \begin{pmatrix} \hat{x} \\ \hat{\varphi} \end{pmatrix} = \begin{pmatrix} 0 \\ 0 \end{pmatrix}.$$

Non-trivial solutions of this equation exist if its determinant vanishes

$$\begin{vmatrix} -\omega^2 + \omega_x^2 & -\frac{l}{4}\omega^2 \\ -\frac{3}{2l}\omega^2 & -\omega^2 + \omega_\varphi^2 \end{vmatrix} = 0.$$

Computing the determinant, we get the following characteristic equation

$$(-\omega^2 + \omega_x^2)(-\omega^2 + \omega_\varphi^2) - \frac{3}{8}\omega^4 = 0,$$

yielding two roots

$$\omega_{1,2}^2 = \frac{4}{5} \left(\omega_x^2 + \omega_\varphi^2 \mp \sqrt{(\omega_x^2 + \omega_\varphi^2)^2 - \frac{5}{2}\omega_x^2\omega_\varphi^2} \right).$$

EXERCISE 2.3. A rigid bar of mass m and moment of inertia $J_S = m\rho^2$ is hung on two massless and unstretchable ropes of equal length l (this is the primitive mechanical model of the swing). The distance between the ropes in the equilibrium state is s . The distances between the attachment points and the center of mass of the bar are s_1 and s_2 , respectively. Under the assumption $\varphi_1 \ll 1$, $\varphi_2 \ll 1$ derive the equations of out-of-plane vibration of the bar, neglecting its in-plane motion. Determine the eigenfrequencies of vibrations.

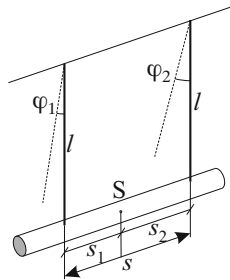

Fig. 2.16 Bar hung on two ropes

Solution. The motion of the bar as rigid body is the superposition of the translation of the center of mass S and the rotation about S. Accordingly, the kinetic energy of the bar equals

$$K = \frac{1}{2}mv_S^2 + \frac{1}{2}J_S\omega^2,$$

where ω is the angular velocity and J_S the moment of inertia of the bar about S. This motion can also be regarded as the pure rotation about the instantaneous center of rotation P with the same angular velocity ω (see Fig. 2.17).

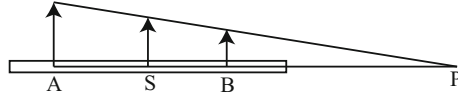

Fig. 2.17 Pure rotation of the bar about P

The velocities of the attachment points A and B are $l\dot{\varphi}_1$ and $l\dot{\varphi}_2$, respectively. Let the distance between A and P be x , then the distance between B and P is $x - s_1 - s_2$, so

$$\begin{aligned} x\omega &= l\dot{\varphi}_1, \\ (x - s_1 - s_2)\omega &= l\dot{\varphi}_2. \end{aligned}$$

From here we find that

$$\omega = \frac{l}{s_1 + s_2}(\dot{\varphi}_1 - \dot{\varphi}_2), \quad x = \frac{(s_1 + s_2)\dot{\varphi}_1}{\dot{\varphi}_1 - \dot{\varphi}_2}.$$

The velocity of the center of mass, v_S , can also be easily found as

$$v_S = (x - s_1)\omega = l \left(\frac{s_2}{s_1 + s_2}\dot{\varphi}_1 + \frac{s_1}{s_1 + s_2}\dot{\varphi}_2 \right).$$

Thus, the kinetic energy of the bar reads

$$K = \frac{1}{2}ml^2 \left(\frac{s_2}{s_1 + s_2}\dot{\varphi}_1 + \frac{s_1}{s_1 + s_2}\dot{\varphi}_2 \right)^2 + \frac{1}{2}m\rho^2 \frac{l^2}{(s_1 + s_2)^2} (\dot{\varphi}_1 - \dot{\varphi}_2)^2.$$

To write down the potential energy of the bar we find out the change of height of the center of mass. The changes of height of the attachment points A and B are

$$w_1 = l(1 - \cos \varphi_1) \approx l \frac{\varphi_1^2}{2}, \quad w_2 = l(1 - \cos \varphi_2) \approx l \frac{\varphi_2^2}{2}.$$

For the bar, the change of height must be a linear function of x :

$$w(x) = ax + b,$$

where x is the coordinate along the bar axis. Choosing $x = 0$ at A, we find that $b = w_1$. For $x = s_1 + s_2$ at B we have $a(s_1 + s_2) + w_1 = w_2$, so

$$a = \frac{w_2 - w_1}{s_1 + s_2}.$$

Consequently, the change of height of the center of mass equals

$$w_S = \frac{l}{2(s_1 + s_2)}(s_2\phi_1^2 + s_1\phi_2^2),$$

and the potential energy reads

$$U = \frac{mgl}{2(s_1 + s_2)}(s_2\phi_1^2 + s_1\phi_2^2).$$

Combining the kinetic and potential energies, we obtain the Lagrange function in the form

$$L = \frac{ml^2}{2(s_1 + s_2)^2}(s_2\dot{\phi}_1 + s_1\dot{\phi}_2)^2 + \frac{m\rho^2 l^2}{2(s_1 + s_2)^2}(\dot{\phi}_1 - \dot{\phi}_2)^2 - \frac{mgl}{2(s_1 + s_2)}(s_2\phi_1^2 + s_1\phi_2^2).$$

Lagrange's equations

$$\frac{d}{dt} \frac{\partial L}{\partial \dot{\phi}_j} - \frac{\partial L}{\partial \phi_j} = 0, \quad j = 1, 2$$

lead to

$$\begin{aligned} \frac{d}{dt} \left[\frac{ml^2 s_2}{(s_1 + s_2)^2} (s_2 \dot{\phi}_1 + s_1 \dot{\phi}_2) + \frac{m\rho^2 l^2}{(s_1 + s_2)^2} (\dot{\phi}_1 - \dot{\phi}_2) \right] + \frac{mgl s_2}{s_1 + s_2} \phi_1 &= 0, \\ \frac{d}{dt} \left[\frac{ml^2 s_1}{(s_1 + s_2)^2} (s_2 \dot{\phi}_1 + s_1 \dot{\phi}_2) - \frac{m\rho^2 l^2}{(s_1 + s_2)^2} (\dot{\phi}_1 - \dot{\phi}_2) \right] + \frac{mgl s_1}{s_1 + s_2} \phi_2 &= 0. \end{aligned}$$

Dividing both equations by $ml^2/(s_1 + s_2)^2$, we reduce them to

$$\begin{aligned} (s_2^2 + \rho^2)\ddot{\phi}_1 + (s_1 s_2 - \rho^2)\ddot{\phi}_2 + \frac{g s s_2}{l} \phi_1 &= 0, \\ (s_1 s_2 - \rho^2)\ddot{\phi}_1 + (s_1^2 + \rho^2)\ddot{\phi}_2 + \frac{g s s_1}{l} \phi_2 &= 0, \end{aligned}$$

where $s = s_1 + s_2$.

To determine the eigenfrequencies of vibrations we seek for the solution in the form

$$\phi_j = \hat{\phi}_j e^{i\omega t}.$$

Substituting this into the equations of motion, we get

$$\begin{pmatrix} \left(\frac{g s s_2}{l} - (s_2^2 + \rho^2)\omega^2 \right) & -(s_1 s_2 - \rho^2)\omega^2 \\ -(s_1 s_2 - \rho^2)\omega^2 & \left(\frac{g s s_1}{l} - (s_1^2 + \rho^2)\omega^2 \right) \end{pmatrix} \begin{pmatrix} \hat{\phi}_1 \\ \hat{\phi}_2 \end{pmatrix} = \begin{pmatrix} 0 \\ 0 \end{pmatrix}.$$

From the condition of vanishing determinant, we get the following characteristic equation

$$\left(\frac{g s s_2}{l} - (s_2^2 + \rho^2)\omega^2\right)\left(\frac{g s s_1}{l} - (s_1^2 + \rho^2)\omega^2\right) - (s_1 s_2 - \rho^2)^2 \omega^4 = 0,$$

which can be reduced to

$$\rho^2 \omega^4 - \frac{g}{l}(s_1 s_2 + \rho^2)\omega^2 + \frac{g^2}{l^2} s_1 s_2 = 0.$$

Solving this quadratic equation (with respect to ω^2), we obtain two roots

$$\omega_1^2 = \frac{g}{l}, \quad \omega_2^2 = \frac{g s_1 s_2}{l \rho^2}.$$

EXERCISE 2.4. Beating phenomenon. Find solution of (2.7) for the coupled pendulums satisfying the initial conditions: $\varphi_1(0) = 1, \varphi_2(0) = \dot{\varphi}_1(0) = \dot{\varphi}_2(0) = 0$. Plot $\varphi_1(t)$ and $\varphi_2(t)$ for $\alpha = 0.1$ and analyze their behaviors.

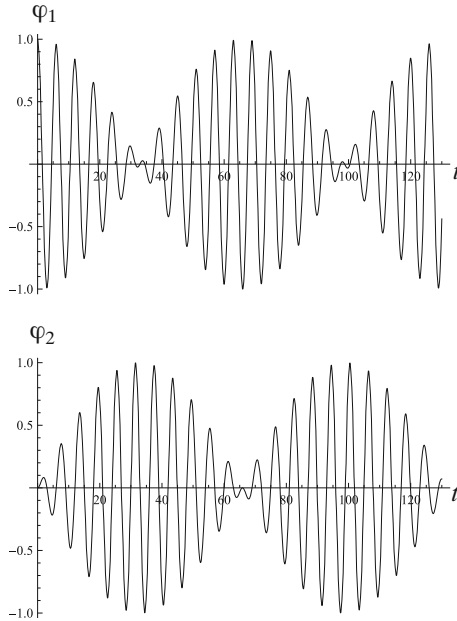

Fig. 2.18 Free vibrations of the coupled pendulums ($\omega_0 = 1, \alpha = 0.1$)

Solution. As shown in Section 2.1, the solution to equations (2.3) describing the vibration of the coupled pendulums is given by

$$\boldsymbol{\varphi} = \begin{pmatrix} \varphi_1 \\ \varphi_2 \end{pmatrix} = \mathbf{q}_1(A_1 \cos \omega_1 t + B_1 \sin \omega_1 t) + \mathbf{q}_2(A_2 \cos \omega_2 t + B_2 \sin \omega_2 t),$$

with $\omega_1 = \omega_0 = \sqrt{g/l}$, $\omega_2 = \sqrt{\omega_0^2 + 2\alpha}$, and

$$\mathbf{q}_1 = \frac{1}{\sqrt{2}} \begin{pmatrix} 1 \\ 1 \end{pmatrix}, \quad \mathbf{q}_2 = \frac{1}{\sqrt{2}} \begin{pmatrix} -1 \\ 1 \end{pmatrix}.$$

To compute the coefficients we use the initial conditions

$$\boldsymbol{\varphi}(0) = \boldsymbol{\varphi}_0 = \begin{pmatrix} 1 \\ 0 \end{pmatrix}, \quad \dot{\boldsymbol{\varphi}}(0) = \dot{\boldsymbol{\varphi}}_0 = \begin{pmatrix} 0 \\ 0 \end{pmatrix},$$

together with the orthogonality and normalization conditions. We easily find that

$$A_1 = \frac{1}{\sqrt{2}}, \quad A_2 = -\frac{1}{\sqrt{2}}, \quad B_1 = B_2 = 0.$$

Thus, the solution is

$$\varphi_1(t) = \frac{1}{2}(\cos \omega_1 t + \cos \omega_2 t), \quad \varphi_2(t) = \frac{1}{2}(\cos \omega_1 t - \cos \omega_2 t).$$

According to the addition formulas

$$\varphi_1(t) = \cos \omega' t \cos \varepsilon t, \quad \varphi_2(t) = \sin \omega' t \sin \varepsilon t,$$

where, for small α ,

$$\omega' = \frac{1}{2}(\omega_1 + \omega_2) \approx \omega_0, \quad \varepsilon = \frac{1}{2}(\omega_2 - \omega_1) \approx \frac{1}{2} \frac{\alpha}{\omega_0}.$$

Thus, $\varphi_1(t)$ and $\varphi_2(t)$ oscillate with the frequency ω' but with slowly changing amplitude $\cos \varepsilon t$ and $\sin \varepsilon t$, respectively. This is the so called beating phenomenon (or amplitude modulation) typical for the oscillation with two nearly equal frequencies.

To simulate this solution numerically we put $\omega_1 = \omega_0 = 1$ and $\alpha = 0.1$ so that $\omega_2 = \sqrt{1 + 2\alpha} \approx 1.095$. The plots of $\varphi_1(t)$ and $\varphi_2(t)$ are shown in Fig. 2.18, from which it is seen that the second pendulum begins to oscillate when the first comes to rest and vice versa. Thus, the energy is transferred from the first to the second pendulum and back.

EXERCISE 2.5. Consider a pair of uncoupled harmonic oscillators described by the equations $\ddot{x} + x = 0$ and $\ddot{y} + \omega^2 y = 0$. Using t as parameter, plot the trajectory of the motion in the (x, y) -plane given by $x(t) = \cos t$ and $y(t) = \cos \omega t$ for $t \in (0, 1000)$ in two cases: i) $\omega = 3$ and ii) $\omega = \pi$. The curves of this type are called Lissajous

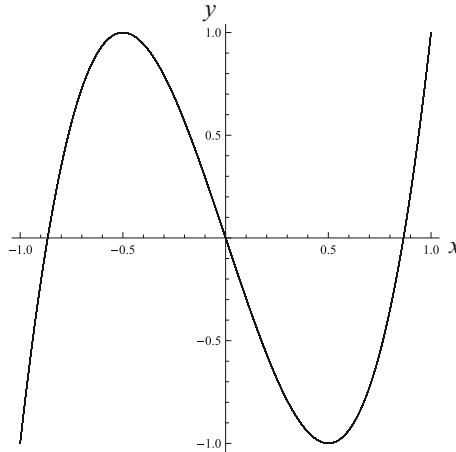

Fig. 2.19 Lissajous figure for $\omega = 3$

figures, and due to the periodicity in x and y the trajectories can be regarded as moving on a two-dimensional torus. Observe the difference in cases i) and ii).

Solution. In case i) the frequency ratio is equal to 3 which is a rational number. In case ii) the frequency ratio is π which is an irrational number. The plots of the trajectories of motion in the (x, y) -plane, made with the help of ParametricPlot command in *Mathematica*, are shown in Fig. 2.19 and 2.20 for the case i) and ii), respectively. In case i) the trajectory is periodic, with the period 2π . In case ii) the trajectory is non-periodic and for an infinitely large interval of time it is dense on the whole domain $(-1, 1) \times (-1, 1)$. Such motion is classified as quasi-periodic. Note that, due to the periodicity in x and y , one can wrap the square $(-1, 1) \times (-1, 1)$ onto the cylinder along the lines $x = \pm 1$ and then onto the torus along the lines $y = \pm 1$. Thus, the trajectories can be regarded as moving on a two-dimensional torus. The difference between cases i) and ii) is:

i) the frequency ratio is a rational number, and each trajectory is a closed periodic orbit on the torus;

ii) the frequency ratio is an irrational number, and each trajectory winds around endlessly on the torus and corresponds to the quasi-periodic motion.

EXERCISE 2.6. Determine the vibration modes and the normal coordinates of the double pendulum with $m_1 = m_2 = m$ and $l_1 = l_2 = l$.

Solution. Under the conditions $m_1 = m_2 = m$ and $l_1 = l_2 = l$ the Lagrange function, as seen from the solution of the exercise 2.1, is given by

$$L = \frac{1}{2}ml^2\dot{\varphi}_1^2 + \frac{1}{2}ml^2(\dot{\varphi}_1 + \dot{\varphi}_2)^2 - mgl\varphi_1^2 - \frac{1}{2}mgl\varphi_2^2.$$

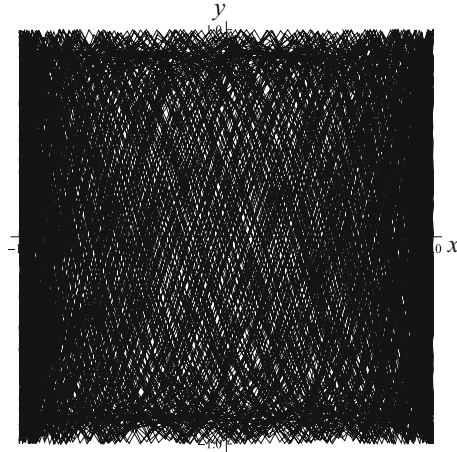

Fig. 2.20 Lissajous figure for $\omega = \pi$

The division of this Lagrange function by ml^2 does not influence the equations of motion, so we can write

$$L = \frac{1}{2}\dot{\phi}_1^2 + \frac{1}{2}(\dot{\phi}_1 + \dot{\phi}_2)^2 - \omega_0^2\phi_1^2 - \frac{1}{2}\omega_0^2\phi_2^2,$$

where $\omega_0^2 = g/l$. The equation of motion in the matrix form reads

$$\mathbf{M}\ddot{\mathbf{q}} + \mathbf{K}\mathbf{q} = \mathbf{0},$$

where

$$\mathbf{M} = \begin{pmatrix} 2 & 1 \\ 1 & 1 \end{pmatrix}, \quad \mathbf{K} = \begin{pmatrix} 2\omega_0^2 & 0 \\ 0 & \omega_0^2 \end{pmatrix}.$$

The problem is to bring both matrices to the diagonal form. This can be realized by solving the eigenvalue problem

$$(-\omega^2\mathbf{M} + \mathbf{K})\hat{\mathbf{q}} = \mathbf{0},$$

or

$$\begin{pmatrix} -2\omega^2 + 2\omega_0^2 & -\omega^2 \\ -\omega^2 & -\omega^2 + \omega_0^2 \end{pmatrix} \begin{pmatrix} \hat{q}_1 \\ \hat{q}_2 \end{pmatrix} = \begin{pmatrix} 0 \\ 0 \end{pmatrix}.$$

The characteristic equation

$$\det(-\omega^2\mathbf{M} + \mathbf{K}) = 2(\omega^2 - \omega_0^2)^2 - \omega^4 = 0$$

yields two eigenfrequencies

$$\omega_{1,2}^2 = \omega_0^2(2 \mp \sqrt{2}).$$

The corresponding normalized eigenvectors of these two modes of vibrations are

$$\mathbf{q}_1 = \frac{1}{\sqrt{2(2+\sqrt{2})}} \begin{pmatrix} 1 \\ \sqrt{2} \end{pmatrix} \approx \begin{pmatrix} 0.382683 \\ 0.541196 \end{pmatrix},$$

$$\mathbf{q}_2 = \frac{1}{\sqrt{2(2-\sqrt{2})}} \begin{pmatrix} -1 \\ \sqrt{2} \end{pmatrix} \approx \begin{pmatrix} -0.92388 \\ 1.30656 \end{pmatrix}.$$

With these eigenvectors we form the modal matrix

$$\mathbf{Q} = \begin{pmatrix} 0.382683 & -0.92388 \\ 0.541196 & 1.30656 \end{pmatrix},$$

which has the inverse

$$\mathbf{Q}^{-1} = \begin{pmatrix} 1.30656 & 0.92388 \\ -0.541196 & 0.382683 \end{pmatrix}.$$

Since the normal coordinates are $\boldsymbol{\xi} = \mathbf{Q}^{-1}\mathbf{q}$, we obtain

$$\xi_1 = 1.30656\varphi_1 + 0.92388\varphi_2, \quad \xi_2 = -0.541196\varphi_1 + 0.382683\varphi_2.$$

EXERCISE 2.7. Determine the vibration modes and the normal coordinates in exercise 2.3.

Solution. From the solution of exercise 2.3 we see that there are two eigenfrequencies of vibrations

$$\omega_1^2 = \frac{g}{l}, \quad \omega_2^2 = \frac{gs_1s_2}{l\rho^2}.$$

Let us find out the corresponding eigenvectors. For mode 1 with $\omega_1^2 = \frac{g}{l}$ we have

$$\frac{g}{l} \begin{pmatrix} s_1s_2 - \rho^2 & -(s_1s_2 - \rho^2) \\ -(s_1s_2 - \rho^2) & s_1s_2 - \rho^2 \end{pmatrix} \begin{pmatrix} q_1 \\ q_2 \end{pmatrix} = \begin{pmatrix} 0 \\ 0 \end{pmatrix}.$$

Together with the normalization condition $\mathbf{q}_1 \cdot \mathbf{M}\mathbf{q}_1 = 1$ we find that

$$\mathbf{q}_1 = \begin{pmatrix} 1/s \\ 1/s \end{pmatrix}.$$

Thus, this mode of vibration corresponds to the synchronized parallel motion of the bar with $\varphi_1 = \varphi_2$ (the swing mode). For mode 2 with $\omega_2^2 = \frac{gs_1s_2}{l\rho^2}$ we have

$$\frac{g}{l} \begin{pmatrix} ss_2 - (s_2^2 + \rho^2)\frac{s_1s_2}{\rho^2} & -(s_1s_2 - \rho^2)\frac{s_1s_2}{\rho^2} \\ -(s_1s_2 - \rho^2)\frac{s_1s_2}{\rho^2} & ss_1 - (s_1^2 + \rho^2)\frac{s_1s_2}{\rho^2} \end{pmatrix} \begin{pmatrix} q_1 \\ q_2 \end{pmatrix} = \begin{pmatrix} 0 \\ 0 \end{pmatrix}.$$

Consequently,

$$\frac{q_2}{q_1} = \frac{ss_2 - (s_2^2 + \rho^2) \frac{s_1 s_2}{\rho^2}}{(s_1 s_2 - \rho^2) \frac{s_1 s_2}{\rho^2}} = -\frac{s_2}{s_1}.$$

Together with the normalization condition $\mathbf{q}_2 \cdot \mathbf{M}\mathbf{q}_2 = 1$ we find that

$$\mathbf{q}_2 = \frac{1}{\rho s} \begin{pmatrix} -s_1 \\ s_2 \end{pmatrix}.$$

This mode of vibration describes the rotation of the bar about the center of mass (antisymmetric mode). Thus, the modal matrix equals

$$\mathbf{Q} = \begin{pmatrix} 1/s & -s_1/(\rho s) \\ 1/s & s_2/(\rho s) \end{pmatrix}.$$

and the normal coordinates are $\boldsymbol{\xi} = \mathbf{Q}^{-1}\mathbf{q}$.

EXERCISE 2.8. Find the coordinates of the fixed points A and B of the resonance curves in example 2.8. Show that A and B are at equal level when

$$\kappa = \frac{\mu}{(1 + \mu)^2}.$$

Solution. Let us analyze the resonance function

$$\left| \frac{x_1}{x_{10}} \right| = \left| \frac{-\mu\eta^2 + i\delta\eta + \kappa}{(-\eta^2 + i\delta\eta + 1 + \kappa)(-\mu\eta^2 + i\delta\eta + \kappa) - (i\delta\eta + \kappa)^2} \right|.$$

Expanding the nominator and denominator on the right-hand side, we obtain

$$\left| \frac{x_1}{x_{10}} \right| = \left| \frac{-\mu\eta^2 + \kappa + i\delta\eta}{(-\eta^2 + 1 + \kappa)(-\mu\eta^2 + \kappa) - \kappa^2 + i\delta\eta(-\mu\eta^2 - \eta^2 + 1)} \right|.$$

Thus,

$$\left| \frac{x_1}{x_{10}} \right|^2 = \frac{\delta^2\eta^2 + (\kappa - \mu\eta^2)^2}{\delta^2\eta^2(-\mu\eta^2 - \eta^2 + 1)^2 + [(-\eta^2 + 1 + \kappa)(-\mu\eta^2 + \kappa) - \kappa^2]^2}.$$

Let us first consider the limiting case of vanishing damping: $\delta = 0$. In this case the resonance function becomes

$$\left| \frac{x_1}{x_{10}} \right| = \frac{|\kappa - \mu\eta^2|}{|(-\eta^2 + 1 + \kappa)(-\mu\eta^2 + \kappa) - \kappa^2|}.$$

In the other extreme case with $\delta \rightarrow \infty$ we have

$$\left| \frac{x_1}{x_{10}} \right| = \frac{1}{|-\eta^2(\mu + 1) + 1|}.$$

Since x_1/x_{10} near the fixed points has different signs in these two cases, the η -coordinates of the fixed points A and B satisfy the equation

$$\frac{\kappa - \mu\eta^2}{(-\eta^2 + 1 + \kappa)(-\mu\eta^2 + \kappa) - \kappa^2} = \frac{1}{\eta^2(\mu + 1) - 1},$$

or

$$(\mu^2 + 2\mu)\eta^4 - 2(\kappa + \kappa\mu + \mu)\eta^2 + 2\kappa = 0.$$

The resonance function for other δ can be presented in the form

$$\left| \frac{x_1}{x_{10}} \right|^2 = \frac{M\delta^2 + N}{P\delta^2 + Q}$$

so that it will be independent of δ^2 only if $M/P = N/Q$ which is again identical with the above equation. From this equation two roots η_1^2 and η_2^2 can be found, which determine the coordinates of A and B. The ordinates of points A and B are obtained by substituting these roots in the resonance function for the case $\delta \rightarrow \infty$. Since the signs of this function is positive at A and negative at B, the ordinates are

$$\frac{1}{-\mu\eta_1^2 - \eta_1^2 + 1} \quad \text{and} \quad \frac{1}{\mu\eta_2^2 + \eta_2^2 - 1}.$$

We want to choose the parameters of absorber in such a way that points A and B are at equal level. This requires that

$$\frac{1}{-\mu\eta_1^2 - \eta_1^2 + 1} = \frac{1}{\mu\eta_2^2 + \eta_2^2 - 1},$$

or

$$\eta_1^2 + \eta_2^2 = \frac{2}{1 + \mu}.$$

Taking into account that η_1^2 and η_2^2 are the roots of the quadratic equation, we obtain

$$\frac{2(\kappa + \kappa\mu + \mu)}{\mu^2 + 2\mu} = \frac{2}{1 + \mu},$$

which implies that

$$\kappa = \frac{\mu}{(1 + \mu)^2}.$$

EXERCISE 2.9. Find the solution of example 2.9 by the Laplace transform and show that it is equal to the solution found by the modal decomposition.

Solution. Dividing equations (2.22) describing the motion of these coupled pendulums by ml^2 , we rewrite them as

$$\begin{aligned} \ddot{\phi}_1 - \chi(\dot{\phi}_2 - \dot{\phi}_1) + \omega_0^2\phi_1 - \alpha(\phi_2 - \phi_1) &= 0, \\ \ddot{\phi}_2 + \chi(\dot{\phi}_2 - \dot{\phi}_1) + \omega_0^2\phi_2 + \alpha(\phi_2 - \phi_1) &= f(t), \end{aligned}$$

where

$$\omega_0 = \sqrt{g/l}, \quad \chi = c/m, \quad \alpha = \frac{k}{4m}, \quad f(t) = \frac{p(t)}{ml}.$$

Let us look for the particular solution of these equations satisfying the homogeneous initial conditions. Applying the Laplace transform to both sides of these equations, we obtain

$$\begin{aligned} s^2 \Phi_1 - \chi s(\Phi_2 - \Phi_1) + \omega_0^2 \Phi_1 - \alpha(\Phi_2 - \Phi_1) &= 0, \\ s^2 \Phi_2 + \chi s(\Phi_2 - \Phi_1) + \omega_0^2 \Phi_2 + \alpha(\Phi_2 - \Phi_1) &= F(s), \end{aligned}$$

where $\Phi_1(s)$, $\Phi_2(s)$, and $F(s)$ are the Laplace images of $\varphi_1(t)$, $\varphi_2(t)$, and $f(t)$, respectively. The latter equations can be represented in the matrix form as

$$\begin{pmatrix} s^2 + \chi s + \omega_0^2 + \alpha & -\chi s - \alpha \\ -\chi s - \alpha & s^2 + \chi s + \omega_0^2 + \alpha \end{pmatrix} \begin{pmatrix} \Phi_1 \\ \Phi_2 \end{pmatrix} = \begin{pmatrix} 0 \\ F(s) \end{pmatrix}.$$

Solving these equation, we find that

$$\Phi_1 = \frac{F(s)(\chi s + \alpha)}{(s^2 + \chi s + \omega_0^2 + \alpha)^2 - (\chi s + \alpha)^2}, \quad \Phi_2 = \frac{F(s)(s^2 + \chi s + \omega_0^2 + \alpha)}{(s^2 + \chi s + \omega_0^2 + \alpha)^2 - (\chi s + \alpha)^2}.$$

To compare with the solution obtained by the modal decomposition let us consider the image functions

$$\Xi_1 = \frac{1}{\sqrt{2}}(\Phi_1 + \Phi_2) = \frac{1}{\sqrt{2}} \frac{F(s)}{s^2 + \omega_0^2},$$

and

$$\Xi_2 = \frac{1}{\sqrt{2}}(\Phi_2 - \Phi_1) = \frac{1}{\sqrt{2}} \frac{F(s)}{s^2 + \omega_0^2 + 2\chi s + 2\alpha} = \frac{1}{\sqrt{2}} \frac{F(s)}{s^2 + \omega_2^2 + 2\chi s}.$$

It is easy to see that the original functions $\xi_1(t)$ and $\xi_2(t)$ corresponding to these image functions satisfy the differential equations

$$\begin{aligned} \ddot{\xi}_1 + \omega_1^2 \xi_1 &= \frac{1}{\sqrt{2}} \frac{p(t)}{ml}, \\ \ddot{\xi}_2 + \frac{2c}{m} \dot{\xi}_2 + \omega_2^2 \xi_2 &= \frac{1}{\sqrt{2}} \frac{p(t)}{ml}. \end{aligned}$$

Thus, the solution obtained by the Laplace transform coincides with the solution obtained by the modal decomposition.

EXERCISE 2.10. A point-mass m moves in the space under the action of three springs of stiffnesses k_1 , k_2 , and k_3 whose axes do not lie in one plane (see Fig. 2.21). The equilibrium position of the point-mass is chosen as the origin of the coordinate

system, while \mathbf{n}_1 , \mathbf{n}_2 , and \mathbf{n}_3 denote the unit vectors along the spring axes. Derive the equation of small vibrations for this oscillator and determine the eigenfrequencies.

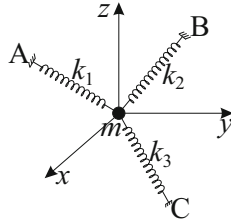

Fig. 2.21 Mass-spring oscillator with 3 degrees of freedom

Solution. Let $\mathbf{r} = (x, y, z)$ be the position vector of the point-mass. We write down its kinetic energy

$$K(\dot{\mathbf{r}}) = \frac{1}{2}m\dot{\mathbf{r}} \cdot \dot{\mathbf{r}} = \frac{1}{2}m(\dot{x}^2 + \dot{y}^2 + \dot{z}^2).$$

The potential energy of the springs reads

$$U(\mathbf{r}) = \frac{1}{2}[k_1(\Delta l_1)^2 + k_2(\Delta l_2)^2 + k_3(\Delta l_3)^2],$$

where Δl_i is the change of length of i -th spring. Let l_{0i} be the original length of the springs. Then the position vectors of points A, B, C are $\mathbf{r}_i = l_{0i}\mathbf{n}_i$, $i = 1, 2, 3$, respectively. The change of length of i -th spring equals

$$\Delta l_i = l_i - l_{0i} = \sqrt{(l_{0i}\mathbf{n}_i - \mathbf{r}) \cdot (l_{0i}\mathbf{n}_i - \mathbf{r})} - l_{0i}.$$

Using the smallness of \mathbf{r} , it is easy to see that

$$\sqrt{(l_{0i}\mathbf{n}_i - \mathbf{r}) \cdot (l_{0i}\mathbf{n}_i - \mathbf{r})} \approx l_{0i}\sqrt{1 - \frac{2}{l_{0i}}\mathbf{n}_i \cdot \mathbf{r}} \approx l_{0i} - \mathbf{n}_i \cdot \mathbf{r}.$$

Thus,

$$\Delta l_i = -\mathbf{n}_i \cdot \mathbf{r},$$

and the potential energy of the springs becomes

$$U(\mathbf{r}) = \frac{1}{2}[k_1(\mathbf{n}_1 \cdot \mathbf{r})^2 + k_2(\mathbf{n}_2 \cdot \mathbf{r})^2 + k_3(\mathbf{n}_3 \cdot \mathbf{r})^2].$$

Now Lagrange's equation

$$\frac{d}{dt} \frac{\partial L}{\partial \dot{\mathbf{r}}} - \frac{\partial L}{\partial \mathbf{r}} = 0$$

yields the equation of motion

$$m\ddot{\mathbf{r}} + k_1\mathbf{n}_1(\mathbf{n}_1 \cdot \mathbf{r}) + k_2\mathbf{n}_2(\mathbf{n}_2 \cdot \mathbf{r}) + k_3\mathbf{n}_3(\mathbf{n}_3 \cdot \mathbf{r}) = 0.$$

To find the eigenfrequencies, we look for the solution in the form

$$\mathbf{r}(t) = \hat{\mathbf{r}}e^{i\omega t},$$

where $\hat{\mathbf{r}}$ is a constant vector. Substituting this solution Ansatz into the equation of motion, we obtain

$$(-m\omega^2\mathbf{I} + \mathbf{K})\hat{\mathbf{r}} = 0.$$

Here \mathbf{I} is the 3×3 identity matrix, and \mathbf{K} is the stiffness matrix with the components

$$K_{ij} = k_1n_{1i}n_{1j} + k_2n_{2i}n_{2j} + k_3n_{3i}n_{3j}.$$

Therefore, the eigenfrequencies should be found from the equation

$$\det(-m\omega^2\mathbf{I} + \mathbf{K}) = 0.$$

This equation can be simplified if the unit vectors \mathbf{n}_1 , \mathbf{n}_2 , \mathbf{n}_3 are mutually orthogonal. By choosing the coordinate system with these vectors as basis vectors, the stiffness matrix becomes also diagonal

$$\mathbf{K} = \begin{pmatrix} k_1 & 0 & 0 \\ 0 & k_2 & 0 \\ 0 & 0 & k_3 \end{pmatrix}.$$

Thus, in this case the equations become uncoupled and the eigenfrequencies are given by

$$\omega_j = \sqrt{k_j/m}, \quad j = 1, 2, 3.$$

Correspondingly, the eigenvectors are \mathbf{n}_1 , \mathbf{n}_2 , \mathbf{n}_3 .

EXERCISE 2.11. A pre-stretched string contains three equal and equally spaced point-masses m (see Fig. 2.22). The tension in the string is assumed to be large so that for small lateral displacements of the point-masses it does not change appreciably. Derive the equation of small lateral vibration and determine the eigenfrequencies.

Solution. Let the displacements of the point-masses from their equilibrium positions be x_1 , x_2 , and x_3 (see Fig. 2.22). The kinetic energy of the point-masses is

$$K = \frac{1}{2}m(\dot{x}_1^2 + \dot{x}_2^2 + \dot{x}_3^2).$$

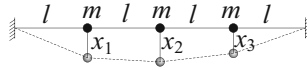

Fig. 2.22 Pre-stretched string with 3 point-masses

We denote the tension in the string by S . Since S is large, the potential energy of the string equals

$$U = S(\Delta l_1 + \Delta l_2 + \Delta l_3 + \Delta l_4),$$

where Δl_i are the changes of lengths of the string segments. Let us express these changes in terms of x_i

$$\begin{aligned}\Delta l_1 &= \sqrt{l^2 + x_1^2} - l = l(\sqrt{1 + (x_1/l)^2} - 1) \approx \frac{1}{2}l\left(\frac{x_1}{l}\right)^2, \\ \Delta l_2 &= \sqrt{l^2 + (x_2 - x_1)^2} - l \approx \frac{1}{2}l\left(\frac{x_2 - x_1}{l}\right)^2, \\ \Delta l_3 &= \sqrt{l^2 + (x_3 - x_2)^2} - l \approx \frac{1}{2}l\left(\frac{x_3 - x_2}{l}\right)^2, \\ \Delta l_4 &= \sqrt{l^2 + x_3^2} - l \approx \frac{1}{2}l\left(\frac{x_3}{l}\right)^2.\end{aligned}$$

Here the smallness of x_i compared with l as well as the formula $\sqrt{1 + \varepsilon} \approx 1 + \frac{1}{2}\varepsilon$ are used. Introducing $x_0 = x_4 = 0$, we may present the potential energy in the form

$$U = \frac{S}{2l}[(x_1 - x_0)^2 + (x_2 - x_1)^2 + (x_3 - x_2)^2 + (x_4 - x_3)^2].$$

With the Lagrange function $L = K - U$ it is easy to derive the equations of motion

$$m\ddot{x}_j + k(x_j - x_{j-1}) + k(x_j - x_{j+1}) = 0, \quad j = 1, 2, 3,$$

where $k = S/l$. We look for the solution of these coupled equations in the form

$$x_j = \hat{x}_j \cos(\omega t - \phi),$$

where \hat{x}_j are the amplitudes of vibrations. With this Ansatz we reduce the differential equations to the algebraic equations

$$(2k - \omega^2 m)\hat{x}_j - k(\hat{x}_{j-1} + \hat{x}_{j+1}) = 0,$$

or to

$$(2 - \eta^2)\hat{x}_j - (\hat{x}_{j-1} + \hat{x}_{j+1}) = 0,$$

where $\eta^2 = \omega^2 m/k$. As the amplitudes of vibrations are determined up to an arbitrary constant factor, we normalize them by

$$\kappa_j = \frac{\hat{x}_j}{\hat{x}_1}, \quad j = 0, 1, 2, 3, 4.$$

The above system becomes

$$(2 - \eta^2)\kappa_j - (\kappa_{j-1} + \kappa_{j+1}) = 0.$$

Thus, knowing $\kappa_0 = 0$, $\kappa_1 = 1$, we can successively determine other κ_j according to

$$\kappa_j = (2 - \eta^2)\kappa_{j-1} - \kappa_{j-2}, \quad j = 2, 3, 4.$$

So,

$$\kappa_2 = -\eta^2 + 2, \quad \kappa_3 = \eta^4 - 4\eta^2 + 3, \quad \kappa_4 = -\eta^6 + 6\eta^4 - 10\eta^2 + 4.$$

Since $\kappa_4 = 0$, we obtain the following equation to determine the eigenfrequencies

$$-\eta^6 + 6\eta^4 - 10\eta^2 + 4 = 0.$$

The alternative method of solution is based on the following Ansatz

$$\hat{x}_j = C \sin j\alpha.$$

This Ansatz satisfies the boundary condition $\hat{x}_0 = 0$. The other boundary condition $\hat{x}_4 = 0$ will be satisfied if

$$4\alpha = k\pi, \quad k = 1, 2, 3 \quad \Rightarrow \quad \alpha = \frac{k\pi}{4}.$$

On the other side, substituting the above Ansatz into the algebraic equations for \hat{x}_j , we obtain

$$C \sin j\alpha(2 - \eta^2 - 2 \cos \alpha) = 0.$$

Since C cannot be zero, we obtain the equation to determine the eigenfrequencies

$$\eta^2 = 2(1 - \cos \alpha) = 4 \sin^2 \frac{\alpha}{2}.$$

Denoting by $\omega_0 = \sqrt{k/m} = \sqrt{S/ml}$, we can write

$$\omega_k = 2\omega_0 \sin \frac{\alpha}{2} = 2\omega_0 \sin \frac{k\pi}{8}, \quad k = 1, 2, 3.$$

EXERCISE 2.12. The free vibrations of an airplane can be described in a simplified model with three degrees of freedom representing the motion of the fuselage and the wings which are connected with the fuselage by the spiral springs of stiffnesses k_1 and k_2 (see Fig. 2.23). Derive the equations of small vibrations. Under the assumptions of symmetry $\theta_1 = \theta_2 = \theta$, $m_1 = m_2 = m$, and $k_1 = k_2 = k$, find the eigenfrequencies of vibrations.

Solution. Let the changes in angles of the wings be φ_1 and φ_2 . We write down the kinetic energy of this system

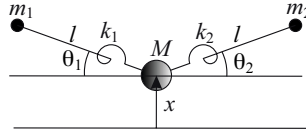

Fig. 2.23 A primitive model of an airplane with 3 degrees of freedom

$$K = \frac{1}{2}M\dot{x}^2 + \frac{1}{2}m_1v_1^2 + \frac{1}{2}m_2v_2^2.$$

The velocity of the point-mass m_1 is $\mathbf{v}_1 = \mathbf{v}_M + \mathbf{v}_{rel}$, where \mathbf{v}_{rel} denotes the relative velocity. Since the vertical and horizontal components of this relative velocity are $l\dot{\phi}_1 \cos \theta_1$ and $-l\dot{\phi}_1 \sin \theta_1$, respectively, we have

$$v_1^2 = \dot{x}^2 + 2l \cos \theta_1 \dot{x} \dot{\phi}_1 + l^2 \dot{\phi}_1^2.$$

Similarly,

$$v_2^2 = \dot{x}^2 + 2l \cos \theta_2 \dot{x} \dot{\phi}_2 + l^2 \dot{\phi}_2^2.$$

Thus, the kinetic energy of the system becomes

$$K = \frac{1}{2}(M + m_1 + m_2)\dot{x}^2 + m_1 l \cos \theta_1 \dot{x} \dot{\phi}_1 + \frac{1}{2}m_1 l^2 \dot{\phi}_1^2 + m_2 l \cos \theta_2 \dot{x} \dot{\phi}_2 + \frac{1}{2}m_2 l^2 \dot{\phi}_2^2.$$

It is easy to show that the static spring forces, the gravitational forces, and the aerodynamic force due to the steady state flow do not contribute to the potential energy. Therefore

$$U = \frac{1}{2}k_1 \phi_1^2 + \frac{1}{2}k_2 \phi_2^2.$$

With $L = K - U$ we derive from Lagrange's equations

$$\begin{aligned} (M + m_1 + m_2)\ddot{x} + m_1 l \cos \theta_1 \ddot{\phi}_1 + m_2 l \cos \theta_2 \ddot{\phi}_2 &= 0, \\ m_1 l^2 \ddot{\phi}_1 + m_1 l \cos \theta_1 \ddot{x} + k_1 \phi_1 &= 0, \\ m_2 l^2 \ddot{\phi}_2 + m_2 l \cos \theta_2 \ddot{x} + k_2 \phi_2 &= 0. \end{aligned}$$

Let $\mathbf{q}^T = (x, \phi_1, \phi_2)$ and $m_T = M + m_1 + m_2$. Then we can represent the equations of free vibrations of this system in the matrix form

$$\mathbf{M}\ddot{\mathbf{q}} + \mathbf{K}\mathbf{q} = 0,$$

where

$$\mathbf{M} = \begin{pmatrix} m_T & m_1 l \cos \theta_1 & m_2 l \cos \theta_2 \\ m_1 l \cos \theta_1 & m_1 l^2 & 0 \\ m_2 l \cos \theta_2 & 0 & m_2 l^2 \end{pmatrix}, \quad \mathbf{K} = \begin{pmatrix} 0 & 0 & 0 \\ 0 & k_1 & 0 \\ 0 & 0 & k_2 \end{pmatrix}.$$

Seeking the particular solution in the form

$$\mathbf{q} = \hat{\mathbf{q}}e^{i\omega t},$$

we obtain the eigenvalue problem

$$(-\omega^2\mathbf{M} + \mathbf{K})\hat{\mathbf{q}} = \mathbf{0}.$$

The related characteristic equation

$$\det(-\omega^2\mathbf{M} + \mathbf{K}) = \begin{vmatrix} -\omega^2 m_T & -\omega^2 m_1 l \cos \theta_1 & -\omega^2 m_2 l \cos \theta_2 \\ -\omega^2 m_1 l \cos \theta_1 & -\omega^2 m_1 l^2 + k_1 & 0 \\ -\omega^2 m_2 l \cos \theta_2 & 0 & -\omega^2 m_2 l^2 + k_2 \end{vmatrix} = 0$$

can be written in the form

$$\omega^2 [l^4(m_T m_1 m_2 - m_1 m_2^2 \cos^2 \theta_2 - m_2 m_1^2 \cos^2 \theta_1)\omega^4 - l^2(m_T(m_1 k_2 + m_2 k_1) - m_2^2 k_1 \cos^2 \theta_2 - m_1^2 k_2 \cos^2 \theta_1)\omega^2 + m_T k_1 k_2] = 0.$$

Thus, there is always the zero frequency corresponding to the mode of vertical motion of the airplane as a rigid body with $x \neq 0$, $\varphi_1 = \varphi_2 = 0$. In the symmetric case ($\theta_1 = \theta_2 = \theta$, $m_1 = m_2 = m$, and $k_1 = k_2 = k$), the remaining factor in the square brackets reduces to

$$m^2 l^4 (m_T - 2m \cos^2 \theta) \omega^4 + 2kml^2 (m \cos^2 \theta - m_T) \omega^2 + m_T k^2 = 0.$$

This yields the following eigenfrequencies

$$\omega_1^2 = \frac{k}{ml^2}, \quad \omega_2^2 = \frac{km_T}{ml^2(m_T - m - m \cos 2\theta)}.$$

Chapter 3

Continuous Oscillators

This Chapter deals with small vibrations of mechanical systems having infinite number of degrees of freedom. It begins with the discrete models of linear chain of oscillators and then moves to the continuum models of strings, beams, membranes, and plates. The last Section is devoted to the most general continuous oscillators. The vibrations of these oscillators can be found in form of the linear superposition of the standing waves leading to the eigenvalue problems in infinite dimensional spaces.

3.1 Chain of Oscillators

Differential Equations of Motion. Crystals having periodic lattice structures with atoms vibrating about the lattice sites can be regarded as mechanical systems with countable number of degrees of freedom. Our aim is to construct mathematical models for such discrete systems with countable number of degrees of freedom by means of the continuum mechanics. Let us first begin with two simple examples.

EXAMPLE 3.1. 1-D chain of mass-spring oscillators. A linear 1-D chain of points of equal mass m connected by springs of equal stiffness k_1 is constrained to move in the longitudinal direction (see Fig. 3.1). Derive the equations of motion.

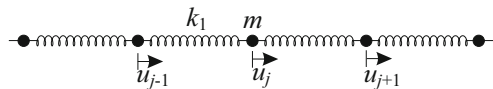

Fig. 3.1 A linear chain of mass-spring-oscillators

In this example the point-masses model atoms, while the springs their nearest neighbor interaction. In equilibrium the distances between neighboring atoms are equal to a lattice constant b . Denoting the displacement of the atom j from its equilibrium position jb by $u_j(t)$, we write down the kinetic energy of the chain

$$K(\dot{u}) = \frac{1}{2}m \sum_j \dot{u}_j^2. \quad (3.1)$$

The potential energy of the chain is the sum of energies of the springs

$$U(u) = \frac{1}{2}k_1 \sum_j (u_j - u_{j-1})^2. \quad (3.2)$$

Thus, Lagrange's equations of this chain read

$$m\ddot{u}_j + k_1(u_j - u_{j-1}) - k_1(u_{j+1} - u_j) = 0$$

for all $j = 1, \dots, n-1$ except the end points of the chain.

EXAMPLE 3.2. 1-D chain of atoms with next-to-nearest-neighbor interaction. Consider the similar 1-D chain of atoms as in the previous example. But now in addition to the springs of stiffness k_1 there are springs of stiffness k_2 connecting the next to nearest neighboring atoms as well (see Fig. 3.2). Derive the equations of longitudinal motion.

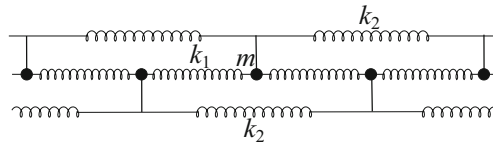

Fig. 3.2 A chain of oscillators with next-to-nearest-neighbor interaction

As before, the kinetic energy of this chain remains the same as (3.1). But its potential energy changes. Because of the presence of the next-to-nearest-neighbor interaction, we have to include energies of the springs of stiffness k_2

$$U(u) = \frac{1}{2}k_1 \sum_j (u_j - u_{j-1})^2 + \frac{1}{2}k_2 \sum_j (u_j - u_{j-2})^2. \quad (3.3)$$

It is interesting to mention that, in some physical situation, we may even assume the negative spring stiffness k_2 . Lagrange's equations of this chain become

$$m\ddot{u}_j + \sum_{l=1}^2 [k_l(u_j - u_{j-l}) - k_l(u_{j+l} - u_j)] = 0 \quad (3.4)$$

for all $j = 2, \dots, n-2$ except the end points of the chain. It is easy to write down the equations of motion for the chain, where each atom interacts with m neighbors to the left as well as with m neighbors to the right (see exercise 3.1).

The derived systems of coupled differential equations are quite difficult to study. However, it turns out that, as $n \rightarrow \infty$, they can be reduced in the long wave limit to one partial differential equation which is easier to solve.

Quasicontinuum. The idea is to set up one-to-one correspondences between functions of discrete argument and functions of continuous argument and between operations on them. Consider the case $n = \infty$ (infinite chain) and let $u(jb) = u_j$ be a function of the discrete argument j defined at the lattice sites. At present, the dependence of u_j on t is suppressed for short; it will be restored in the final stage. We are going to interpolate this function to a smooth function $u(x)$ defined on the whole x -axis such that all wave lengths shorter than b are filtered out. The precise meaning of this can be given in terms of the Fourier transform of $u(x)$ which we denote¹ by $u(k)$

$$u(k) = \mathcal{F}[u(x)] = \int_{-\infty}^{\infty} e^{-ikx} u(x) dx, \quad u(x) = \frac{1}{2\pi} \int_{-\infty}^{\infty} e^{ikx} u(k) dk. \quad (3.5)$$

Namely, we require that the Fourier image $u(k)$ differs from zero only on the segment $B = [-\pi/b, \pi/b]$, called Brillouin zone. Then $u(k)$ can be expanded in a Fourier series on this segment

$$u(k) = \chi_B(k) \sum_j c_j e^{-ijbk}, \quad (3.6)$$

where $\chi_B(k)$ is a characteristic function of the segment B , i.e., $\chi_B(k) = 1$ when $k \in B$ and $\chi_B(k) = 0$ otherwise. Substituting this equation in (3.5) for $u(x)$, we find

$$u(x) = \sum_j c_j \delta_B(x - jb),$$

where

$$\delta_B(x) = \frac{1}{2\pi} \int_B e^{ikx} dk = \frac{\sin(\pi x/b)}{\pi x}.$$

It is easy to see that $\delta_B(x) = \delta_B(-x)$ and

$$\delta_B(0) = \frac{1}{b}, \quad \delta_B(jb) = 0 \quad \text{for } j \neq 0.$$

Thus, if we set $c_j = bu(jb)$, then

$$u(x) = b \sum_j u(jb) \delta_B(x - jb) \quad (3.7)$$

is the required interpolating function, since it is equal to $u(jb)$ at the lattice sites and its Fourier image has the compact support in the Brillouin zone B . It can be proved that (3.7) is a unique and one-to-one correspondence between functions of discrete and continuous argument satisfying these two requirements [27].

¹ This notation involves no risk of confusion as we can see the difference in arguments of $u(x)$ and $u(k)$. Besides, it emphasizes that $u(x)$ and the image $u(k)$ are the same function in x and k spaces.

Based on this one-to-one correspondence, we can now present the Lagrange function of our chain in terms of the continuous function (3.7). First of all, let us show that the following identity

$$\sum_j u^2(jb) = \frac{1}{b} \int u^2(x) dx$$

holds true for an arbitrary function $u(jb)$. Indeed, according to Parseval's identity [47] we have for any real function

$$\int_{-\infty}^{\infty} u^2(x) dx = \frac{1}{2\pi} \int_{-\infty}^{\infty} u^*(k)u(k) dk,$$

where $u^*(k)$ is the complex conjugate of $u(k)$. With $u(k)$ from (3.6) (where $c_j = bu(jb)$) and with the identities

$$\frac{1}{2\pi} \int_B e^{i(l-j)bk} dk = \frac{1}{b} \delta_{jl},$$

we can easily check the required formula. Thus, the kinetic energy of the chain (3.1) can be expressed in terms of $u_{,t}(x, t)$ as

$$K(u_{,t}) = \int \frac{1}{2} \mu u_{,t}^2 dx, \quad (3.8)$$

with the comma in indices denoting the partial derivative and $\mu = m/b$ the mass density per unit length. Let us turn now to the potential energy of the chain and rewrite it in the form

$$U(u) = \frac{1}{2} \sum_{j,l} u_j \Phi(j-l) u_l,$$

where $\Phi(-j) = \Phi(j)$ and for $U(u)$ from (3.2)

$$\Phi(0) = 2k_1, \quad \Phi(1) = -k_1, \quad \Phi(j) = 0 \quad \text{for } |j| > 1.$$

For $U(u)$ from (3.3) we have

$$\Phi(0) = 2(k_1 + k_2), \quad \Phi(1) = -k_1, \quad \Phi(2) = -k_2, \quad \Phi(j) = 0 \quad \text{for } |j| > 2,$$

and this can easily be generalized for chains with m interacting neighbors, $m > 2$. Applying the convolution theorem and Parseval's identity, we have for any real function $u(x)$ and $\Phi(x)$

$$\int_{-\infty}^{\infty} \int_{-\infty}^{\infty} u(x) \Phi(x-y) u(y) dx dy = \frac{1}{2\pi} \int_{-\infty}^{\infty} u^*(k) \Phi(k) u(k) dk, \quad (3.9)$$

where

$$\Phi(k) = \int_{-\infty}^{\infty} \Phi(x) e^{-ikx} dx.$$

Now, if we set

$$\Phi(k) = \frac{1}{b} \sum_j \Phi(j) e^{-ijbk}, \quad k \in B, \quad (3.10)$$

and substitute it into the right-hand side of (3.9), we obtain

$$U(u) = \frac{1}{2} \sum_{j,l} u_j \Phi(j-l) u_l = \frac{1}{2} \int_{-\infty}^{\infty} \int_{-\infty}^{\infty} u(x) \Phi(x-y) u(y) dx dy.$$

Thus, the action functional can be presented in terms of the function $u(x, t)$ as

$$I[u(x, t)] = \int_{t_0}^{t_1} dt \int_{-\infty}^{\infty} \left[\frac{1}{2} \mu u_{,t}^2 - \frac{1}{2} \int_{-\infty}^{\infty} u(x, t) \Phi(x-y) u(y, t) dy \right] dx \quad (3.11)$$

Varying the action functional, we easily obtain the following integral equation

$$\mu u_{,tt} + \int_{-\infty}^{\infty} \Phi(x-y) u(y, t) dy = 0, \quad (3.12)$$

which is equivalent to the system of equations (3.4). Note that equation (3.12) can also be directly obtained from (3.4).

Dispersion Curve and Long-Wave Approximation. Since equation (3.12) is linear, we seek its solution in the form

$$u(x, t) = a e^{i(kx - \omega t)}. \quad (3.13)$$

This solution corresponds to the wave propagating along the x -axis, with a being the amplitude, k the wave number, and ω the frequency of vibration. Substitution of (3.13) into (3.12) leads to the dispersion relation between k and ω

$$-\mu \omega^2 + \Phi(k) = 0. \quad (3.14)$$

For the chain with the nearest neighbor interaction we have from (3.10)

$$\Phi(k) = \frac{2k_1}{b} (1 - \cos bk) = \frac{4k_1}{b} \sin^2 \frac{bk}{2}, \quad k \in B.$$

Denoting by $\omega_0 = \sqrt{k_1/m}$, we present the dimensionless dispersion curve $\nu = \omega/\omega_0$ versus $\kappa = bk$ in Fig. 3.3.

For the propagating wave (3.13) the characteristic wavelength is $l = 2\pi/k = 2\pi b/\kappa$. If this characteristic wavelength is much larger than the lattice constant b , then $\kappa \ll 1$ and function $\Phi(k)$ can be approximated by

$$\Phi(k) = \frac{4k_1}{b} \sin^2 \frac{bk}{2} \approx \frac{k_1}{b} (bk)^2. \quad (3.15)$$

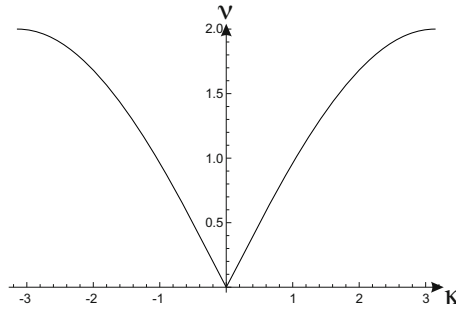

Fig. 3.3 Dispersion curve for a chain with nearest neighbor interaction

This approximation simplifies considerably the potential energy in the action functional and makes the theory local. Indeed, using the property of the Fourier transform

$$\frac{1}{2\pi} \int k^2 u^*(k) u(k) dk = \int_{-\infty}^{\infty} u_{,x}^2 dx,$$

we write the potential energy in the form

$$U(u) = \frac{k_1 b}{2} \int_{-\infty}^{\infty} u_{,x}^2 dx.$$

Thus, the action functional becomes

$$I[u(x,t)] = \int_{t_0}^{t_1} dt \int_{-\infty}^{\infty} \left(\frac{1}{2} \mu u_t^2 - \frac{1}{2} k_1 b u_{,x}^2 \right) dx, \quad (3.16)$$

which yields the following Lagrange's equation

$$\mu u_{,tt} - k_1 b u_{,xx} = 0. \quad (3.17)$$

This type of partial differential equations will be studied in the next Sections within the continuum mechanics.

3.2 String

Differential Equation of Motion. In previous Section the transition from discrete to continuum descriptions has been demonstrated. Let us now derive the equation of motion directly within the framework of continuum mechanics. We start with simple one-dimensional continua.

EXAMPLE 3.3. Flexural vibration of string. Derive the equation of small flexural vibration of a pre-stretched string.

Under string we mean a thin pre-stretched elastic body with negligible bending stiffness whose diameter of the cross-section is much smaller than its length l . We shall model the string by a one-dimensional continuum. We show first the derivation based on the force method. Let x be the coordinate along the string axis, $x \in (0, l)$, and $w(x, t)$ the transverse displacement of the string. We also denote by $\alpha(x, t)$ the slope of the curve $w(x, t)$. For small vibration both $w(x, t)$ and $\alpha(x, t)$ are small so that $\alpha = w_x$. The tension is assumed to be large, and the change of stress along the string during the vibration is negligibly small compared with this tension. We cut a part of the deformed string from x to $x + \Delta x$ and free it from the rest. Keeping in mind the free body diagram shown in Fig. 3.4, we apply Newton's law in the transverse direction,

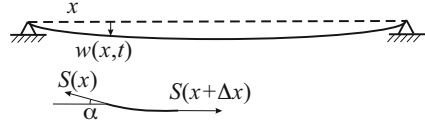

Fig. 3.4 Flexural vibration of string

where $S(x)$ and $S(x + \Delta x)$ are the forces from the surrounding exerted on the cut part of the string, $\mu(x)$ the mass per unit length, and, due to the smallness of α , $\sin \alpha$ is approximately replaced by α in this equation. Dividing both sides by Δx and letting $\Delta x \rightarrow 0$, we obtain in the limit

$$\mu(x)\Delta x w_{,tt} = S(x + \Delta x)\alpha(x + \Delta x, t) - S(x)\alpha(x, t),$$

where $S(x)$ and $S(x + \Delta x)$ are the forces from the surrounding exerted on the cut part of the string, $\mu(x)$ the mass per unit length, and, due to the smallness of α , $\sin \alpha$ is approximately replaced by α in this equation. Dividing both sides by Δx and letting $\Delta x \rightarrow 0$, we obtain in the limit

$$\mu(x)w_{,tt} = \frac{\partial}{\partial x}[S(x)w_{,x}(x, t)].$$

Here the slope α is replaced by w_x , with comma denoting the partial derivative with respect to x . For the homogeneous string with constant cross-section area A the mass density per unit length does not depend on x : $\mu(x) = \rho A = \mu$. We also assume that $S(x) = S$, where S/A is the tension in the equilibrium state. Dividing the above equation by μ , we reduce it to the standard form

$$w_{,tt} = c^2 w_{,xx}(x, t), \quad c = \sqrt{\frac{S}{\mu}}. \tag{3.18}$$

This equation is subject to the boundary conditions

$$w(0, t) = w(l, t) = 0. \tag{3.19}$$

The energy method is based on Hamilton's variational principle of least action: among all admissible motions $w(x, t)$ satisfying the initial and end conditions

$$w(x, t_0) = w_0(x), \quad w(x, t_1) = w_1(x)$$

and the boundary conditions (3.19) the true motion is the extremal of the action functional

$$I[w(x,t)] = \int_{t_0}^{t_1} \int_0^l L(w, w_x, w_t) dx dt.$$

The consequence of Hamilton's variational principle is Euler-Lagrange's equation (see the derivation in Section 3.6)

$$\frac{\partial}{\partial t} \frac{\partial L}{\partial w_t} + \frac{\partial}{\partial x} \frac{\partial L}{\partial w_x} - \frac{\partial L}{\partial w} = 0. \quad (3.20)$$

Thus, the motion of the conservative one-dimensional continuum is governed by a single function $L(w, w_x, w_t)$, called Lagrangian, which is given by

$$L(w, w_x, w_t) = K(w_t) - U(w, w_x),$$

where $K(w_t)$ is the kinetic and $U(w, w_x)$ the internal energy densities. In our example the kinetic energy density is equal to

$$K(w_t) = \frac{1}{2} \mu w_t^2.$$

The internal energy density (per unit length) must be a function of the strain ε : $U = U(\varepsilon)$. Denoting the strain in the pre-stretched state as $\varepsilon = \varepsilon_0$, we expand the energy density in Taylor's series near this state:

$$U(\varepsilon) = U(\varepsilon_0) + U'(\varepsilon_0)(\varepsilon - \varepsilon_0) + \dots$$

Neglecting the unessential constant $U(\varepsilon_0)$ as well as terms of higher orders and taking into account that $U'(\varepsilon_0) = S$, we obtain

$$U(\varepsilon) = S(\varepsilon - \varepsilon_0).$$

Now, for the transverse displacement considered above

$$\varepsilon - \varepsilon_0 = \lim_{\Delta x \rightarrow 0} \frac{\sqrt{(\Delta x)^2 + (w(x + \Delta x) - w(x))^2} - \Delta x}{\Delta x} \approx \frac{1}{2} w_x^2.$$

Thus, the internal energy density depends only on w_x , $U(w, w_x) = \frac{1}{2} S w_x^2$, and

$$L(w, w_x, w_t) = \frac{1}{2} \mu w_t^2 - \frac{1}{2} S w_x^2.$$

Substitution of this Lagrangian into (3.20) leads again to the equation of motion (3.18).

EXAMPLE 3.4. Longitudinal vibration of bar. Derive the equation of small longitudinal vibration of an elastic bar.

Under bar we mean a thin elastic body whose diameter of the cross-section is much smaller than the length l of the bar. Let x be the coordinate along the bar axis, $x \in (0, l)$, and $u(x, t)$ the longitudinal displacement of the bar. The kinetic energy

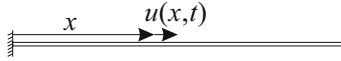

Fig. 3.5 Longitudinal vibration of bar

per unit length of the bar is given by

$$K(u_t) = \frac{1}{2}\rho A(x)u_t^2,$$

while the internal energy per unit length by

$$U(u_x) = \frac{1}{2}EA(x)u_x^2.$$

Here we denote by ρ the mass density, $A(x)$ the cross-section area which may vary along the bar axis, and E the Young modulus. With the Lagrangian $L(u_x, u_t) = K(u_t) - U(u_x)$ we derive from (3.20)

$$\rho A(x)u_{,tt} = \frac{\partial}{\partial x}[EA(x)u_{,x}(x,t)],$$

and, if $A(x) = \text{const}$, reduce it to the standard form (3.18) with $c = \sqrt{E/\rho}$ and w being replaced by u .

EXAMPLE 3.5. Torsional vibration of bar. Derive the equation of small torsional vibration of an elastic bar.



Fig. 3.6 Torsional vibration of bar

Let $\varphi(x,t)$ be the rotation angle of the cross-section in its own plane. The kinetic energy per unit length of the bar is given by

$$K(\varphi_t) = \frac{1}{2}\rho J_p(x)\varphi_t^2,$$

while the internal energy per unit length by

$$U(\varphi_x) = \frac{1}{2}GJ_p(x)\varphi_x^2.$$

Here $J_p(x)$ corresponds to the polar moment of inertia of the cross-section, and G the shear modulus. With $L(\varphi_x, \varphi_t) = K(\varphi_t) - U(\varphi_x)$ we derive from Euler-Lagrange's equation

$$\rho J_p(x) \varphi_{,tt} = \frac{\partial}{\partial x} [G J_p(x) \varphi_{,x}(x, t)],$$

which, for $J_p(x) = \text{const}$, can again be reduced to the standard form (3.18) with $c = \sqrt{G/\rho}$ and w being replaced by φ .

Solution. We first seek particular solutions of equation (3.18) and then construct the general solution using the linear superposition principle. We assume the particular solution of the form

$$w(x, t) = q(x)u(t).$$

As this particular solution is the product of two functions depending separately on x and t , the corresponding method of solution is called separation of variables. Plugging this Ansatz into equation (3.18) and assuming that neither $q(x)$ nor $u(t)$ is identically zero, we divide the obtained equation by $q(x)u(t)$ to get

$$\frac{\ddot{u}}{u} = c^2 \frac{q''}{q}.$$

Since the left-hand side expression depends on t while its right-hand side counterpart depends only on x , the equation implies that both must be a constant which we denote by $-\omega^2$. Thus, we obtain two ordinary differential equations

$$\begin{aligned} \ddot{u} + \omega^2 u &= 0, \\ q'' + \left(\frac{\omega}{c}\right)^2 q &= 0. \end{aligned} \quad (3.21)$$

The solution of the second equation reads

$$q(x) = A \cos \frac{\omega}{c} x + B \sin \frac{\omega}{c} x.$$

The boundary conditions (3.19) require that $q(0) = q(l) = 0$, so $A = 0$ and the non-trivial solution exists if

$$\sin \frac{\omega}{c} l = 0 \quad \Rightarrow \quad \omega = \omega_j = j \frac{\pi c}{l}, \quad j = 1, 2, \dots \quad (3.22)$$

Thus,

$$q_j(x) = B_j \sin \frac{j\pi}{l} x.$$

We may fix the coefficients B_j by choosing some normalization condition. As such we propose

$$\int_0^l q_j^2(x) dx = 1 \quad \Rightarrow \quad q_j(x) = \sqrt{\frac{2}{l}} \sin \frac{j\pi}{l} x.$$

Functions $q_j(x)$ describe the shapes of normal modes and are called eigenfunctions (or standing waves). Function $q_1(x)$ corresponds to the shape of mode with the

lowest frequency (or the fundamental tone). Functions $q_j(x)$ with $j > 1$ describe the shape of modes with higher frequencies (called overtones). The eigenfunction $q_j(x)$ has $j - 1$ fix points which do not move (one speaks of the vibration nodes). Fig. 3.7 shows three first eigenfunctions. It turns out that the functions $q_j(x)$ are orthogonal in the following sense

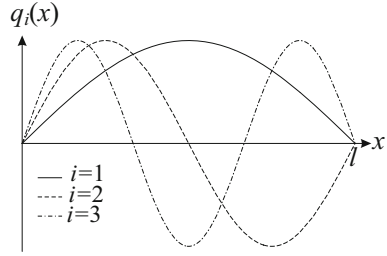

$$\int_0^l q_j(x)q_k(x) dx = 0 \quad \text{for } j \neq k.$$

Fig. 3.7 Three first eigenfunctions

This can easily be checked by using the well-known trigonometric formula for sine function.

The first equation of (3.21) for $\omega = \omega_j$ has the solution

$$u(t) = a_j \cos \omega_j t + b_j \sin \omega_j t.$$

Now, the general solution of equation (3.18) satisfying the boundary conditions (3.19) is obtained in form of the Fourier series

$$w(x,t) = \sqrt{\frac{2}{l}} \sum_{j=1}^{\infty} \sin \frac{j\pi}{l} x (a_j \cos \omega_j t + b_j \sin \omega_j t).$$

We have to satisfy also the initial conditions

$$w(x,0) = w_0(x), \quad w_t(x,0) = v_0(x).$$

With the above solution we obtain from the initial conditions

$$\begin{aligned} \sqrt{\frac{2}{l}} \sum_{j=1}^{\infty} a_j \sin \frac{j\pi}{l} x &= w_0(x), \\ \sqrt{\frac{2}{l}} \sum_{j=1}^{\infty} \omega_j b_j \sin \frac{j\pi}{l} x &= v_0(x). \end{aligned} \tag{3.23}$$

To determine the unknown coefficients a_j and b_j we multiply these equations with the eigenfunction $q_k(x) = \sqrt{\frac{2}{l}} \sin \frac{k\pi}{l} x$ and integrate over x from 0 to l . Using the orthogonality and normalization conditions, we obtain

$$a_j = \sqrt{\frac{2}{l}} \int_0^l w_0(x) \sin \frac{j\pi}{l} x dx, \quad b_j = \sqrt{\frac{2}{l}} \frac{1}{\omega_j} \int_0^l v_0(x) \sin \frac{j\pi}{l} x dx.$$

In the harmonic analysis [12, 56] it is proved that if functions $w_0(x)$ and $v_0(x)$ are continuous and piecewise continuously differentiable, then the Fourier series (3.23) converge uniformly to $w_0(x)$ and $v_0(x)$ in the interval $(0, l)$. Thus, the eigenfunctions found above form a complete orthogonal basis for this class of initial data.

3.3 Beam

Bernoulli-Euler's Beam Theory. Under beam we mean a thin elastic body whose undeformed axis is a straight segment of length l . The thickness h of the beam is assumed to be much smaller than its length l . Let x be the coordinate along the beam axis, $x \in (0, l)$, and $w(x, t)$ the transverse displacement of the beam axis in the (x, y) -plane (see Fig. 3.8).

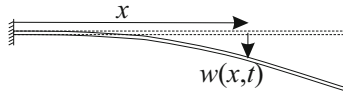

Fig. 3.8 Flexural vibration of beam

According to Bernoulli-Euler's beam theory the kinetic energy density of the beam is equal to

$$K(w, t) = \frac{1}{2} \mu w_{,t}^2,$$

where μ is the mass per unit length. The internal energy density of the beam must be a quadratic function of the curvature of the deformed beam axis $w_{,xx}$

$$U(w_{,xx}) = \frac{1}{2} EJ (w_{,xx})^2,$$

with EJ being the bending stiffness. Thus, the action functional reads

$$I[w(x, t)] = \int_{t_0}^{t_1} \int_0^l L(w_{,xx}, w_{,t}) dx dt,$$

where

$$L(w_{,xx}, w_{,t}) = \frac{1}{2} \mu w_{,t}^2 - \frac{1}{2} EJ (w_{,xx})^2. \quad (3.24)$$

The difference between this Lagrangian and those in the previous Section is the presence of the second derivative in the internal energy density.

We first consider the case of clamped edges such that

$$w(0, t) = w(l, t) = 0, \quad w_{,x}(0, t) = w_{,x}(l, t) = 0. \quad (3.25)$$

The second condition of (3.25) means the vanishing rotation angle of the beam about the clamped edge. Hamilton's variational principle of least action for the beam states

that among all admissible motions $w(x, t)$ satisfying the initial and end conditions

$$w(x, t_0) = w_0(x), \quad w(x, t_1) = w_1(x)$$

and the boundary conditions (3.25) the true motion is the extremal of the action functional

$$\delta I[w(x, t)] = \delta \int_{t_0}^{t_1} \int_0^l L(w_{,xx}, w_{,t}) dx dt = 0.$$

To derive the equation of flexural vibration from this variational principle we calculate the first variation of the action functional

$$\delta I = \int_{t_0}^{t_1} \int_0^l (\mu w_{,t} \delta w_{,t} - EJ w_{,xx} \delta w_{,xx}) dx dt = 0. \quad (3.26)$$

Integrating by parts over x and t and using the initial and end conditions as well as the clamped boundary conditions, we obtain

$$\delta I = \int_{t_0}^{t_1} \int_0^l (-\mu w_{,tt} - EJ w_{,xxxx}) \delta w dx dt = 0.$$

Since δw can be chosen arbitrarily inside the region $(0, l) \times (t_0, t_1)$, the variational equation implies that

$$\mu w_{,tt} + EJ w_{,xxxx} = 0. \quad (3.27)$$

Note that Hamilton's principle applies to other boundary conditions as well. Practically, there are three types of boundary conditions at x_* ($x_* = 0$ or $x_* = l$) corresponding to:

- a) Clamped edge: $w(x_*, t) = w_{,x}(x_*, t) = 0$.
- b) Simply supported edge: $w(x_*, t) = 0$, but $w_{,x}(x_*, t)$ may be varied arbitrarily.
- c) Free edge: both $w(x_*, t)$ and $w_{,x}(x_*, t)$ may be varied arbitrarily.

Provided equation (3.27) is fulfilled, we reduce equation (3.26) for the variations not vanishing at the boundaries to

$$\delta I = \int_{t_0}^{t_1} (-EJ w_{,xx} \delta w_{,x} + EJ w_{,xxx} \delta w) \Big|_{x=0}^{x=l} dt = 0.$$

Thus, from the last equation we see that, in case b) the additional boundary condition obtained from Hamilton's principle is

$$w_{,xx}(x_*, t) = 0,$$

which means the vanishing bending moment. In case c) the boundary conditions read

$$w_{,xx}(x_*, t) = 0, \quad w_{,xxx}(x_*, t) = 0,$$

which mean the vanishing bending moment and shear force. Contrary to the kinematic (or essential) boundary conditions of the type $w(x_*, t) = 0$ or $w_{,x}(x_*, t) = 0$, the

additional boundary conditions derived from Hamilton's principle are called natural boundary conditions.

Solution. The method of solution is quite similar to that considered in previous Section. We first seek a particular solution of the form

$$w(x, t) = q(x)u(t).$$

The separation of variables in (3.27) leads to

$$\frac{\ddot{u}}{u} = -\frac{EJ}{\mu} \frac{q''''}{q}.$$

The left-hand side expression depends on t while its right-hand side counterpart depends only on x , therefore two ordinary differential equations follow

$$\begin{aligned}\ddot{u} + \omega^2 u &= 0, \\ q'''' - \kappa^4 q &= 0,\end{aligned}$$

with $\kappa^4 = \omega^2 \mu / EJ$. The solution of the second equation reads

$$q(x) = C_1 \sin \kappa x + C_2 \cos \kappa x + C_3 \sinh \kappa x + C_4 \cosh \kappa x.$$

Consider, for example, the beam which is simply supported at $x = 0$ and $x = l$. In this case the boundary conditions require that

$$q(0) = q''(0) = 0, \quad q(l) = q''(l) = 0.$$

So we get four homogeneous equations for four coefficients C_1 , C_2 , C_3 , and C_4 . Dividing the equations $q''(0) = 0$ and $q''(l) = 0$ by κ^2 and rewriting them in one matrix equation, we have

$$\begin{pmatrix} 0 & 1 & 0 & 1 \\ 0 & -1 & 0 & 1 \\ \sin \lambda & \cos \lambda & \sinh \lambda & \cosh \lambda \\ -\sin \lambda & -\cos \lambda & \sinh \lambda & \cosh \lambda \end{pmatrix} \begin{pmatrix} C_1 \\ C_2 \\ C_3 \\ C_4 \end{pmatrix} = \begin{pmatrix} 0 \\ 0 \\ 0 \\ 0 \end{pmatrix},$$

where $\lambda = \kappa l$. The non-trivial solution exists if the determinant of the matrix vanishes giving

$$\sin \lambda \sinh \lambda = 0 \quad \Rightarrow \quad \lambda_j = j\pi, \quad j = 1, 2, \dots \quad (3.28)$$

For $\lambda_j = j\pi$ the above equation implies that $C_1 \neq 0$, $C_2 = C_3 = C_4 = 0$. We fix C_1 by the normalization condition

$$\int_0^l q_j^2(x) dx = 1 \quad \Rightarrow \quad q_j(x) = \sqrt{\frac{2}{l}} \sin \frac{j\pi}{l} x.$$

Thus, the eigenfunctions $q_j(x)$ for the beam with the supported edges remain the same as the shapes of normal modes of the string.

With $\lambda_j = j\pi$ we obtain for the eigenfrequencies

$$\omega_j = \lambda_j^2 \sqrt{\frac{EJ}{\mu l^4}} = (j\pi)^2 \sqrt{\frac{EJ}{\mu l^4}}, \quad j = 1, 2, \dots \tag{3.29}$$

Note that the frequencies are proportional to j^2 . The first equation for $u(t)$ has the solution

$$u(t) = a_j \cos \omega_j t + b_j \sin \omega_j t.$$

Now, the general solution is obtained in form of the Fourier series

$$w(x, t) = \sqrt{\frac{2}{l}} \sum_{j=1}^{\infty} \sin \frac{j\pi}{l} x (a_j \cos \omega_j t + b_j \sin \omega_j t),$$

where the coefficients a_j and b_j should be determined from the initial data $w_0(x)$ and $v_0(x)$ by using the orthogonality condition.

Table 3.1 The frequency equations

Boundary conditions	Frequency equation
free-free	$1 - \cos \lambda \cosh \lambda = 0$
supported-free	$\tan \lambda - \tanh \lambda = 0$
clamped-free	$1 + \cos \lambda \cosh \lambda = 0$
supported-supported	$\sin \lambda = 0$
clamped-supported	$\tan \lambda - \tanh \lambda = 0$
clamped-clamped	$1 - \cos \lambda \cosh \lambda = 0$

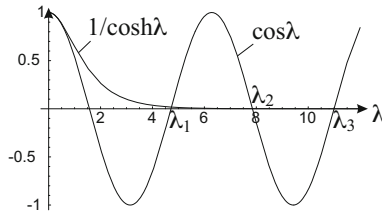

Fig. 3.9 Roots of the frequency equation $1/\cosh \lambda = \cos \lambda$

The modal analysis of the beam with other boundary conditions is similar and the frequency equations are summarized in Table 3.1. Knowing the roots of the frequency equations, one finds the eigenfrequencies in accordance with (3.29). Consider for example the free-free or clamped-clamped edges, for which the frequency

equation is $1/\cosh\lambda = \cos\lambda$. The roots of this transcendental equation correspond to the λ -coordinates of the intersection points of the curves $1/\cosh\lambda$ and $\cos\lambda$ shown in Fig. 3.9, from which it is seen that for $j > 3$ we have approximately $\lambda_j \approx (2j + 1)\pi/2$. Note that the beams with the free edges or with one simply supported edge and one free edge possess also zero frequencies as these types of boundary conditions admit rigid-body motions.

3.4 Membrane

Differential Equation of Motion. Under membrane we mean a thin pre-stretched elastic body with negligible bending stiffness whose thickness is much smaller than other characteristic lengths. The pre-stress is assumed to be large, and the change of stresses in the membrane during its vibration is negligibly small compared with the pre-stress. We shall model the membrane by a two-dimensional continuum occupying the area A in its plane. Let x_1 and x_2 be the Cartesian coordinates in this plane, $\mathbf{x} = (x_1, x_2) \in A$, and $w(\mathbf{x}, t)$ the small transverse displacement of the membrane in the x_3 -direction. Hamilton's variational principle of least action states that, among all admissible motions $w(\mathbf{x}, t)$ satisfying the initial and end conditions

$$w(\mathbf{x}, t_0) = w_0(\mathbf{x}), \quad w(\mathbf{x}, t_1) = w_1(\mathbf{x}),$$

as well as the boundary conditions

$$w(\mathbf{x}, t) = 0 \quad \text{for } \mathbf{x} \in \partial A, \quad (3.30)$$

the true motion is the extremal of the action functional

$$I[w(\mathbf{x}, t)] = \int_{t_0}^{t_1} \int_A L(w, w_{,\alpha}, w_{,t}) dx dt.$$

Here and in what follows, Greek indices numerating the coordinates run from 1 to 2, the comma in indices denotes partial derivatives with respect to the corresponding coordinates, and $dx = dx_1 dx_2$ is the area element. From Hamilton's variational principle we derive Euler-Lagrange's equation (see Section 3.6)

$$\frac{\partial}{\partial t} \frac{\partial L}{\partial w_{,t}} + \frac{\partial}{\partial x_\alpha} \frac{\partial L}{\partial w_{,\alpha}} - \frac{\partial L}{\partial w} = 0. \quad (3.31)$$

We use for short Einstein's summation convention according to which all the terms with repeated indices will be summed up over these indices from 1 to 2. For example, the second term in the above equation reads

$$\frac{\partial}{\partial x_\alpha} \frac{\partial L}{\partial w_{,\alpha}} = \frac{\partial}{\partial x_1} \frac{\partial L}{\partial w_{,1}} + \frac{\partial}{\partial x_2} \frac{\partial L}{\partial w_{,2}}.$$

The motion of membrane is thus governed by the Lagrangian

$$L(w, w_{,\alpha}, w_{,t}) = K(w_{,t}) - U(w, w_{,\alpha}),$$

where $K(w_{,t})$ is the kinetic and $U(w, w_{,\alpha})$ the internal energy densities. The kinetic energy density of the membrane is equal to

$$K(w_{,t}) = \frac{1}{2}\mu w_{,t}^2,$$

with μ being the mass per unit area. The internal energy density (per unit area) must be a function of the strains $\varepsilon_{\alpha\beta}$: $U = U(\varepsilon_{\alpha\beta})$. Without restricting generality we may regard the strains in the pre-stretched state as $\varepsilon = 0$, and expand the energy density in Taylor's series near this state:

$$U(\varepsilon_{\alpha\beta}) = U(0) + \left. \frac{\partial U}{\partial \varepsilon_{\alpha\beta}} \right|_{\varepsilon_{\alpha\beta}=0} \varepsilon_{\alpha\beta} + \dots$$

Neglecting the unessential constant $U(0)$ as well as terms of higher orders and assuming that $\partial U / \partial \varepsilon_{\alpha\beta} |_{\varepsilon_{\alpha\beta}=0} = S\delta_{\alpha\beta}$, with S being the pre-stress, we obtain

$$U(\varepsilon) = S\varepsilon_{\alpha\alpha}.$$

Since $\varepsilon_{\alpha\alpha}$ describes the increase in area of the membrane, which, for the small transverse displacement with $w_{,\alpha} \ll 1$, is equal to

$$\varepsilon_{\alpha\alpha} = \sqrt{1 + w_{,\alpha}w_{,\alpha}} - 1 \approx \frac{1}{2}w_{,\alpha}w_{,\alpha},$$

the internal energy density does not depend on w , $U(w, w_{,\alpha}) = \frac{1}{2}Sw_{,\alpha}w_{,\alpha}$. Thus, the Lagrangian reads

$$L(w, w_{,\alpha}, w_{,t}) = \frac{1}{2}\mu w_{,t}^2 - \frac{1}{2}Sw_{,\alpha}w_{,\alpha}.$$

Plugging this into the equation of motion (3.31), we get finally

$$\mu w_{,tt} - S\Delta w = 0,$$

where $\Delta w = w_{,\alpha\alpha}$ is Laplace's operator applied to w . Bringing the second term to the right-hand side and dividing by μ , we reduce the above equation to the standard form

$$w_{,tt} = c^2 \Delta w, \quad c = \sqrt{\frac{S}{\mu}}. \quad (3.32)$$

Solution. We separate the variables \mathbf{x} and t by seeking the particular solution in the form

$$w(\mathbf{x}, t) = q(\mathbf{x})u(t).$$

Substitution in (3.32) together with the standard arguments lead to

$$\begin{aligned} \ddot{u} + \omega^2 u &= 0, \\ \Delta q + \lambda q &= 0, \end{aligned} \tag{3.33}$$

where $\lambda = \omega^2/c^2$. The second equation of (3.33) is subject to the boundary condition

$$q(\mathbf{x}) = 0 \quad \text{at } \mathbf{x} \in \partial A.$$

The solution of this eigenvalue problem in closed analytical form is possible for rectangular and circular membranes. We consider these special cases.

Rectangular membrane. Let a and b denote the width and the height of the rectangle so that $A = (0, a) \times (0, b)$. We look for the solution of (3.33)₂ in the form

$$q(\mathbf{x}) = X_1(x_1)X_2(x_2).$$

The standard separation of variables leads to

$$\frac{X_1''}{X_1} = -\frac{X_2''}{X_2} - \lambda = -\alpha^2.$$

The equation for $X_1(x_1)$,

$$X_1'' + \alpha^2 X_1 = 0,$$

together with the boundary conditions

$$X_1(0) = X_1(a) = 0,$$

yields

$$X_1(x_1) = C_1 \sin \alpha x_1,$$

where

$$\alpha = j_1 \frac{\pi}{a}, \quad j_1 = 1, 2, \dots$$

Similarly, the equation for $X_2(x_2)$,

$$X_2'' + \beta^2 X_2 = 0,$$

with $\beta^2 = \lambda - \alpha^2$, together with the boundary conditions

$$X_2(0) = X_2(b) = 0,$$

implies that

$$X_2(x_2) = C_2 \sin \beta x_2,$$

where

$$\beta = j_2 \frac{\pi}{b}, \quad j_2 = 1, 2, \dots$$

Denoting by j the vector (j_1, j_2) , we present the eigenfunctions in the form

$$q_j(\mathbf{x}) = C \sin \frac{j_1 \pi x_1}{a} \sin \frac{j_2 \pi x_2}{b}, \quad j_1, j_2 = 1, 2, \dots$$

The corresponding eigenvalues belonging to the spectrum of the rectangular membrane are²

$$\lambda_j = \left(\frac{\omega_j}{c} \right)^2 = \alpha^2 + \beta^2 = \pi^2 \left(\frac{j_1^2}{a^2} + \frac{j_2^2}{b^2} \right).$$

We may fix the constant C by the normalization condition

$$\int_A q_j^2(\mathbf{x}) dx = 1 \quad \Rightarrow \quad C = \frac{2}{\sqrt{ab}}.$$

One can also easily prove that

$$\int_A q_j(\mathbf{x}) q_k(\mathbf{x}) dx = 0 \quad \text{for } j \neq k.$$

Mention that multiple eigenvalues may occur. For rectangles with rational ratios $a : b$ this is always the case. For instance, if $a = b$ (the square membrane), then $j' = (j_2, j_1)$ gives the same eigenvalue as $j = (j_1, j_2)$. Together with the solution of (3.33)₁

$$u_j(t) = a_j \cos \omega_j t + b_j \sin \omega_j t,$$

we construct the general solution of (3.32) by the linear superposition principle

$$w(\mathbf{x}, t) = \frac{2}{\sqrt{ab}} \sum_{j_1, j_2=1}^{\infty} \sin \frac{j_1 \pi x_1}{a} \sin \frac{j_2 \pi x_2}{b} (a_j \cos \omega_j t + b_j \sin \omega_j t).$$

Taking into account the initial conditions

$$w(\mathbf{x}, 0) = w_0(\mathbf{x}), \quad w_t(\mathbf{x}, 0) = v_0(\mathbf{x}),$$

we obtain

$$\begin{aligned} \frac{2}{\sqrt{ab}} \sum_{j_1, j_2=1}^{\infty} a_j \sin \frac{j_1 \pi x_1}{a} \sin \frac{j_2 \pi x_2}{b} &= w_0(x_1, x_2), \\ \frac{2}{\sqrt{ab}} \sum_{j_1, j_2=1}^{\infty} \omega_j b_j \sin \frac{j_1 \pi x_1}{a} \sin \frac{j_2 \pi x_2}{b} &= v_0(x_1, x_2). \end{aligned}$$

The orthogonality property can be used to find the coefficients a_j and b_j from the initial data $w_0(\mathbf{x})$ and $v_0(\mathbf{x})$. In the harmonic analysis [12, 56] it is proved that if

² Let us mention in this connection one interesting and still not completely solved mathematical problem: are there two distinct shapes of membrane having the same spectrum? This question was originally posed by Hermann Weyl and rephrased later by Mark Kac in the following way: "Can one hear the shape of a drum?" (see [22]).

functions $w_0(\mathbf{x})$ and $v_0(\mathbf{x})$ are continuous and piecewise continuously differentiable, then the double Fourier series converge uniformly to $w_0(\mathbf{x})$ and $v_0(\mathbf{x})$ in the square $(0, a) \times (0, b)$. Thus, the eigenfunctions found above form a complete orthogonal basis for this class of initial data.

Circular membrane. For the circular membrane we choose the polar coordinates r and ϑ (see Fig. 3.10) in which equation (3.33)₂ takes the form

$$q_{,rr} + \frac{1}{r}q_{,r} + \frac{1}{r^2}q_{,\vartheta\vartheta} + \lambda q = 0.$$

Looking for the solution of this equation as the product

$$q(r, \vartheta) = R(r)\Theta(\vartheta)$$

and separating the variables, we obtain

$$\frac{R'' + R'/r + \lambda R}{R/r^2} = -\frac{\Theta''}{\Theta} = \kappa^2.$$

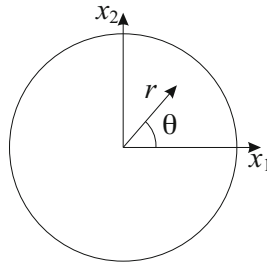

Fig. 3.10 Circular membrane and polar coordinates

Consider first the equation for $\Theta(\vartheta)$

$$\Theta'' + \kappa^2\Theta = 0,$$

which yields the solution

$$\Theta(\vartheta) = \alpha \cos \kappa \vartheta + \beta \sin \kappa \vartheta.$$

It is obvious that function $\Theta(\vartheta)$ must be periodic with the period 2π

$$\Theta(2\pi) = \Theta(0), \quad \Theta'(2\pi) = \Theta'(0).$$

The periodicity implies that $\kappa = j$, where j is a nonnegative integer $j = 0, 1, 2, \dots$. Then the equation for $R(r)$ becomes Bessel's equation [51]

$$R'' + \frac{1}{r}R' + \left(\frac{\omega^2}{c^2} - \frac{j^2}{r^2} \right) R = 0.$$

Its solution is expressed in terms of Bessel's function of order j

$$R = J_j\left(\frac{\omega r}{c}\right).$$

The boundary condition (3.30) at $r = r_m$, with r_m being the radius of the membrane, requires that

$$J_j\left(\frac{\omega r_m}{c}\right) = 0.$$

Thus, the eigenfrequencies are obtained from the zeros of Bessel's function $J_j(x)$, which we denote by ξ_{jk} , $k = 1, 2, \dots$. The eigenfunctions now read

$$q_{jk}(r, \vartheta) = J_j(\xi_{jk}r/r_m)(\alpha_{jk} \cos j\vartheta + \beta_{jk} \sin j\vartheta).$$

The constants α_{jk} and β_{jk} may still be arbitrary, indicating that ξ_{jk} with $j \neq 0$ are at least double eigenvalues.

Together with the solution of (3.33)₁

$$u_{jk}(t) = a_{jk} \cos \omega_{jk}t + b_{jk} \sin \omega_{jk}t,$$

we construct the general solution of (3.32) by the linear superposition principle

$$w = \sum_{j=0, k=1}^{\infty} J_j(\xi_{jk}r/r_m)(\alpha_{jk} \cos j\vartheta + \beta_{jk} \sin j\vartheta)(a_{jk} \cos \omega_{jk}t + b_{jk} \sin \omega_{jk}t).$$

Then the initial conditions

$$w(r, \vartheta, 0) = w_0(r, \vartheta), \quad w_t(r, \vartheta, 0) = v_0(r, \vartheta),$$

yield

$$\begin{aligned} \sum_{j=0, k=1}^{\infty} a_{jk} J_j(\xi_{jk}r/r_m)(\alpha_{jk} \cos j\vartheta + \beta_{jk} \sin j\vartheta) &= w_0(r, \vartheta), \\ \sum_{j=0, k=1}^{\infty} b_{jk} \omega_{jk} J_j(\xi_{jk}r/r_m)(\alpha_{jk} \cos j\vartheta + \beta_{jk} \sin j\vartheta) &= v_0(r, \vartheta). \end{aligned}$$

One can again prove that if functions $w_0(r, \vartheta)$ and $v_0(r, \vartheta)$ are continuous, piecewise continuously differentiable, and periodic in ϑ with the period 2π , then the above double series converge uniformly to them in the domain $(0, r_m) \times (0, 2\pi)$. Thus, the eigenfunctions found above form a complete orthogonal basis for this class of initial data.

3.5 Plate

Kirchhoff's Plate Theory. Under plate we mean a thin elastic body occupying in its undeformed state a region $A \times (-h/2, h/2)$ of the three-dimensional Euclidean point space, where A is an area in the (x_1, x_2) -plane. The thickness h of the plate is assumed to be much smaller than the characteristic sizes of A . We shall model the plate by a two-dimensional continuum. Let $\mathbf{x} = (x_1, x_2) \in A$ and $w(\mathbf{x}, t)$ be the small transverse displacement of the middle plane in the x_3 -direction (see Fig. 3.11).



Fig. 3.11 A thin plate and transverse displacement of the middle plane

According to Kirchhoff's plate theory [24] the kinetic energy density of the plate is equal to

$$K(w, t) = \frac{1}{2} \rho h w_{,t}^2,$$

where ρ is the mass density. The internal energy density of the plate must be a quadratic function of the curvature of the deformed middle surface $w, \alpha\beta$

$$U(w, \alpha\beta) = \frac{\mu h^3}{12} (\sigma w_{, \alpha\alpha}^2 + w, \alpha\beta w, \alpha\beta),$$

with $\sigma = \frac{\lambda}{\lambda + 2\mu}$, λ and μ being the Lamé constants of the elastic material. Thus, the action functional reads

$$I[w(\mathbf{x}, t)] = \int_{t_0}^{t_1} \int_A L(w, \alpha\beta, w, t) dx dt,$$

where

$$L(w, \alpha\beta, w, t) = \frac{1}{2} \rho h w_{,t}^2 - \frac{\mu h^3}{12} (\sigma w_{, \alpha\alpha}^2 + w, \alpha\beta w, \alpha\beta). \quad (3.34)$$

The difference between this action functional and that of the membrane is the presence of the second partial derivatives in the internal energy density. The derivation of (3.34) from the three-dimensional elasticity theory based on the variational-asymptotic method is given in [31].

Since L depends on $w, \alpha\beta$, the action functional “feels” the change of the derivative of w at the boundary ∂A . If the edge of the plate is free, then it is natural to assume that no constraints are imposed on w at the boundary. If the edge of the plate is clamped, we let $I[w]$ be defined on the space of admissible displacement fields $w(\mathbf{x}, t)$ satisfying the kinematic boundary conditions

$$w(\mathbf{x}, t) = 0, \quad w_{,\alpha} v_\alpha = 0 \quad \text{at } \mathbf{x} \in \partial A, \quad (3.35)$$

where v_α denotes the components of the outward unit vector normal to the curve ∂A . The last condition of (3.35) expresses the fact that the rotation angle of the plate about the clamped edge vanishes. Finally, if the edge is simply supported, then only the displacement should vanish

$$w(\mathbf{x}, t) = 0 \quad \text{at } \mathbf{x} \in \partial A. \quad (3.36)$$

Hamilton's variational principle states that, among all admissible motions $w(\mathbf{x}, t)$ satisfying the initial and end conditions

$$w(\mathbf{x}, t_0) = w_0(\mathbf{x}), \quad w(\mathbf{x}, t_1) = w_1(\mathbf{x}),$$

as well as the kinematic boundary conditions, the true motion is the extremal of the action functional

$$\delta I = 0.$$

In order to derive the equations of motion of the plate let us calculate the variation of the action functional

$$\delta I = \int_{t_0}^{t_1} \int_A (\rho h w_{,t} \delta w_{,t} - m_{\alpha\beta} \delta w_{,\alpha\beta}) dx dt, \quad (3.37)$$

where

$$m_{\alpha\beta} = \frac{\partial U}{\partial w_{,\alpha\beta}} = \mu \frac{h^3}{6} (\sigma w_{,\gamma\gamma} \delta_{\alpha\beta} + w_{,\alpha\beta}).$$

From equation (3.37) one can see that $m_{\alpha\beta}$ "works" on the bending (or change of the curvature) of the plate. Therefore it is natural to call $m_{\alpha\beta}$ bending moments.

Integrating (3.37) by parts with the help of Gauss' theorem, we obtain for the variations vanishing at the boundary ∂A

$$\delta I = \int_{t_0}^{t_1} \int_A (-\rho h w_{,tt} - m_{\alpha\beta, \alpha\beta}) \delta w dx dt = 0.$$

Since δw is arbitrary inside the region $A \times (t_0, t_1)$, we conclude that

$$\rho h w_{,tt} + m_{\alpha\beta, \alpha\beta} = 0 \quad \text{or} \quad \rho h w_{,tt} + D \Delta \Delta w = 0, \quad (3.38)$$

where

$$D = \mu(\sigma + 1) \frac{h^3}{6} = \frac{Eh^3}{12(1 - \nu^2)}$$

is the bending stiffness of the plate. This is the two-dimensional equation of flexural vibration of the thin plate.

Provided the equation (3.38) is fulfilled, we reduce the equation $\delta I = 0$ for the variations not vanishing at the boundary to

$$\int_{t_0}^{t_1} \int_{\partial A} (m_{\alpha\beta,\beta} v_\alpha \delta w - m_{\alpha\beta} \delta w_{,\alpha} v_\beta) ds dt = 0, \quad (3.39)$$

where ds is the length element. Now we need to select independent variations at the boundary. The gradient $\delta w_{,\alpha}$ may be resolved in the normal and tangential directions to the boundary as follows:

$$\delta w_{,\alpha} = v_\alpha v_\gamma \delta w_{,\gamma} + \tau_\alpha \tau_\gamma \delta w_{,\gamma}.$$

This is due to the identity $\delta_{\alpha\gamma} = v_\alpha v_\gamma + \tau_\alpha \tau_\gamma$, with τ_α being the components of the vector tangential to the curve ∂A . Since $\tau_\gamma \delta w_{,\gamma} = d\delta w/ds$, we can integrate by parts that term in (3.39) containing it to get

$$\int_{t_0}^{t_1} \int_{\partial A} [m_{\alpha\beta,\beta} v_\alpha \delta w + \frac{d}{ds} (m_{\alpha\beta} \tau_\alpha v_\beta) \delta w - m_{\alpha\beta} v_\alpha v_\beta v_\gamma \delta w_{,\gamma}] ds dt = 0.$$

For the free edge of the plate the variations δw and $v_\gamma \delta w_{,\gamma}$ are arbitrary at ∂A ; hence

$$\begin{aligned} m_{\alpha\beta,\beta} v_\alpha + \frac{d}{ds} (m_{\alpha\beta} \tau_\alpha v_\beta) &= 0, \\ m_{\alpha\beta} v_\alpha v_\beta &= 0. \end{aligned} \quad (3.40)$$

These are the free-edge boundary conditions. For the clamped edge, the kinematic boundary conditions (3.35) should be fulfilled. If the edge is simply supported, (3.36) and (3.40)₂ are the boundary conditions at ∂A .

Frequency Spectra of Circular Plate. We investigate the free vibrations of a circular plate of radius r_m . We look for solutions of the form

$$w(\mathbf{x}, t) = q(\mathbf{x})u(t).$$

The standard separation of variables \mathbf{x} and t leads to

$$D\Delta\Delta q - \rho h\omega^2 q = 0, \quad (3.41)$$

where ω is the frequency of vibration. We introduce the dimensionless variables

$$\zeta_\alpha = \frac{x_\alpha}{r_m}, \quad \beta^4 = \omega^2 \rho h r_m^4 / D = \frac{6\rho\omega^2 r_m^4}{\mu(\sigma+1)h^2}.$$

Now we transform (3.41) to the dimensionless form

$$(\Delta\Delta - \beta^4)q = (\Delta + \beta^2)(\Delta - \beta^2)q = 0. \quad (3.42)$$

Therefore the solution of (3.42) may be written as

$$q = q_1 + q_2,$$

where functions q_1, q_2 satisfy respectively

$$\begin{aligned}\Delta q_1 + \beta^2 q_1 &= 0, \\ \Delta q_2 - \beta^2 q_2 &= 0.\end{aligned}\tag{3.43}$$

These equations can be solved again by the separation of variables. In the polar coordinates r, ϑ (see Fig. 3.10) we have

$$\Delta q = \frac{\partial^2 q}{\partial r^2} + \frac{1}{r} \frac{\partial q}{\partial r} + \frac{1}{r^2} \frac{\partial^2 q}{\partial \vartheta^2}.$$

Assuming $q_1 = R_1(r)\Theta_1(\vartheta)$, from (3.43)₁ we obtain the following differential equation for $\Theta_1(\vartheta)$

$$\Theta_1'' = -\kappa^2 \Theta_1.$$

Since $\Theta_1(\vartheta)$ must be periodic with the period 2π , we find that $\kappa = j$, where j is a nonnegative integer, $j = 0, 1, 2, \dots$, and

$$\Theta_1(\vartheta) = \cos j\vartheta \quad \text{or} \quad \Theta_1(\vartheta) = \sin j\vartheta.$$

Then the equation for $R_1(r)$ reads

$$R_1'' + \frac{1}{r} R_1' + (\beta^2 - \frac{j^2}{r^2}) R_1 = 0.$$

This is Bessel's equation of order j , which has the following non-singular solution

$$R_1 = aJ_j(\beta r).$$

Combination of R_1 and Θ_1 yields

$$q_1 = aJ_j(\beta r) \begin{cases} \cos j\vartheta \\ \sin j\vartheta \end{cases}.$$

For $q_2 = R_2(r)\Theta_2(\vartheta)$ the same results are obtained for $\Theta_2(\vartheta)$, while for $R_2(r)$ the modified Bessel's equation holds true

$$R_2'' + \frac{1}{r} R_2' - (\beta^2 + \frac{j^2}{r^2}) R_2 = 0.$$

The non-singular solution of this equation is given by

$$R_2 = bI_j(\beta r),$$

where $I_j(x)$ is the modified Bessel's function of order j . Combining q_1 and q_2 , we get finally

$$q = [aJ_j(\beta r) + bI_j(\beta r)] \begin{cases} \cos j\vartheta \\ \sin j\vartheta \end{cases} . \tag{3.44}$$

Consider the simplest case of the clamped edge, for which the boundary conditions

$$q|_{r=1} = \frac{\partial}{\partial r} q|_{r=1} = 0 \tag{3.45}$$

hold true. Substituting (3.44) into (3.45) and equating the determinant to zero, we obtain the following frequency equation:

$$J_j(\beta)I'_j(\beta) - I_j(\beta)J'_j(\beta) = 0. \tag{3.46}$$

The three lowest roots β_{jk} of (3.46) for $j = 0, 1, 2$ are given in the following table:

k	$j = 0$	$j = 1$	$j = 2$
1	3.196	4.611	5.906
2	6.306	7.799	9.197
3	9.439	10.958	12.402

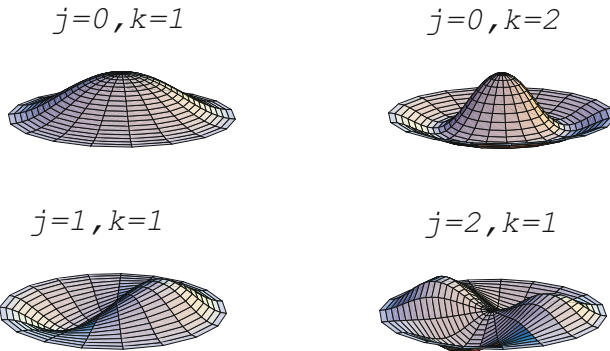

Fig. 3.12 Few normal modes of clamped circular plate

The frequencies of vibrations should be calculated by the formula

$$\omega_{jk} = \frac{\beta_{jk}^2 h}{r_m^2} \sqrt{\frac{\mu}{6(1-\nu)\rho}},$$

while the corresponding eigenfunctions are given by

$$q_{jk} = [J_j(\beta_{jk}r) - \frac{J_j(\beta_{jk})}{I_j(\beta_{jk})}I_j(\beta_{jk}r)] \begin{cases} \cos j\vartheta \\ \sin j\vartheta \end{cases} .$$

A few of the deformed shapes of the plate are shown in Fig. 3.12. Chladni invented an experimental method of observing the nodal lines of vibrations of a plate by pouring a thin layer of sand on its upper face: during the vibration the sand-grains will move to the nodal lines. Such nodal patterns are called Chladni's figures.³

Let us turn to the case of the free edge. The displacement w should then satisfy the boundary conditions (3.40). In the polar coordinates r, ϑ we have

$$\begin{aligned}
 m_{\alpha\beta} \nu_{\alpha} \nu_{\alpha} &= \mu \frac{h^3}{6} (\sigma + 1) \frac{\partial}{\partial r} \Delta q, \\
 m_{\alpha\beta} \tau_{\alpha} \nu_{\beta} &= \mu \frac{h^3}{6} \frac{1}{r} \left(\frac{\partial^2 q}{\partial r \partial \vartheta} - \frac{1}{r} \frac{\partial q}{\partial \vartheta} \right), \\
 m_{\alpha\beta} \nu_{\alpha} \nu_{\beta} &= \mu \frac{h^3}{6} \left(\sigma \Delta q + \frac{\partial^2 q}{\partial r^2} \right).
 \end{aligned}$$

Substituting these into (3.40), we obtain the following conditions at the boundary $r = 1$:

$$\begin{aligned}
 [(\sigma + 1) \frac{\partial}{\partial r} \Delta q + \frac{\partial^3 q}{\partial r \partial \vartheta^2} - \frac{\partial^2 q}{\partial \vartheta^2}]|_{r=1} &= 0, \\
 (\sigma \Delta q + \frac{\partial^2 q}{\partial r^2})|_{r=1} &= 0.
 \end{aligned} \tag{3.47}$$

With q from (3.44) we transform (3.47) to

$$\begin{aligned}
 &a\{-\beta^3 J'_j(\beta) + (1 - \nu) j^2 [J_j(\beta) - \beta J'_j(\beta)]\} \\
 &+ b\{\beta^3 I'_j(\beta) + (1 - \nu) j^2 [I_j(\beta) - \beta I'_j(\beta)]\} = 0, \\
 &a\{-\beta^2 J_j(\beta) + (1 - \nu) [j^2 J_j(\beta) - \beta J'_j(\beta)]\} \\
 &+ b\{\beta^2 I_j(\beta) + (1 - \nu) [j^2 I_j(\beta) - \beta I'_j(\beta)]\} = 0.
 \end{aligned} \tag{3.48}$$

The frequency equation is obtained by the condition of vanishing determinant of (3.48). When $j = 0$, the frequency equation can be presented in a simple form

$$2(1 - \nu) + \beta \frac{J_0(\beta)}{J'_0(\beta)} - \beta \frac{I_0(\beta)}{I'_0(\beta)} = 0.$$

The three lowest roots β_{jk} of the frequency equation for $j = 0, 1, 2$ and $\nu = 0.31$ have the following values:

k	$j = 0$	$j = 1$	$j = 2$
1	0.0	0.0	2.308
2	3.004	4.526	5.938
3	6.202	7.735	9.185

³ One can see such experiments as well as various Chladni's figures, for instance, on the following website: <http://www.youtube.com/watch?v=Qf0t4qIVWF4>

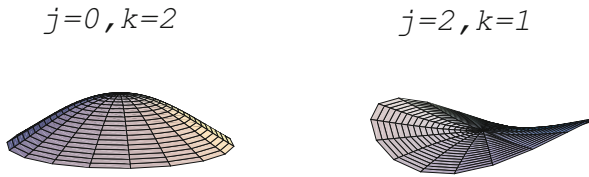

Fig. 3.13 Two normal modes of free circular plate

The first two zero frequencies correspond to the translation $q = a$ and small rotation $q = ar \sin \vartheta$ of the plate without deformation. The frequency according to β_{21} is the lowest one that is positive. Two deformed shapes of the plate for $j = 0, k = 2$ and $j = 2, k = 1$ are shown in Figure 3.13. If we sum up all these particular solutions, the obtained Fourier series converges again uniformly to the solution satisfying arbitrary regular initial conditions. The approximate solution for the rectangular plate can be found in [48].

3.6 General Continuous Oscillators

We present in this Section the variational principles for general continuous oscillators and the method of solution.

Conservative Systems. We model an arbitrary continuous oscillator by a continuum occupying the region V in the d -dimensional space, where $\mathbf{x} = (x_1, \dots, x_d)$ denotes any point of V . We have in all applications $d = 1, 2, 3$. Suppose that each configuration of this continuum is uniquely determined by a set of functions (fields) $u_1(\mathbf{x}), \dots, u_n(\mathbf{x})$. If $u_1(\mathbf{x}), \dots, u_n(\mathbf{x})$ can vary independently and arbitrarily at each point \mathbf{x} of the continuum, they are called generalized displacements, and n a number of degrees of freedom at that point. Motion of the system is described by the time dependent fields $u_i(\mathbf{x}, t)$. We denote by $u_{i,t} = (u_{1,t}, \dots, u_{n,t})$ the corresponding velocities.

Hamilton's variational principle. Hamilton's variational principle of least action states that among all admissible motions of the conservative system satisfying the initial and end conditions

$$u_i(\mathbf{x}, t_0) = u_{i0}(\mathbf{x}), \quad u_i(\mathbf{x}, t_1) = u_{i1}(\mathbf{x}),$$

as well as the boundary conditions

$$u_i(\mathbf{x}, t) = 0 \quad \text{at } \mathbf{x} \in \partial V, \quad (3.49)$$

the true motion is the extremal of the action functional

$$I[u_i(\mathbf{x}, t)] = \int_{t_0}^{t_1} \int_V L(\mathbf{x}, u_i, u_{i,\alpha}, u_{i,t}) dx dt.$$

Here and in what follows, Latin indices numerating the degrees of freedom run from 1 to n , while Greek indices numerating the coordinates run from 1 to d , the comma in indices denotes partial derivatives with respect to the corresponding coordinates, and $dx = dx_1 \dots dx_d$ is the volume element. Before deriving the equations of motion let us consider briefly, without detailed derivations, some further examples of Lagrangian.

EXAMPLE 3.6. Timoshenko's beam theory.

In this one-dimensional model ($d = 1$) we have two degrees of freedom at each point x : the displacement of the beam axis $w(x)$ and function $\psi(x)$ describing the first branch of the thickness-shear vibration of the cross-section. The Lagrangian of the Timoshenko beam is given by

$$L = \frac{1}{2}\rho h^2(w_{,t}^2 + \alpha h^2\psi_{,t}^2) - \frac{1}{2}\mu h^2[sh^2\psi_{,x}^2 + \beta^2\alpha(\psi + w_{,x})^2], \quad (3.50)$$

with ρ being the mass density, h the thickness of the cross-section, μ the shear modulus, and α , s , and β the constants depending on the geometry of the cross-section (see the derivation of this formula in [31]).

EXAMPLE 3.7. Reissner-Mindlin's plate theory.

This is the two-dimensional model ($d = 2$) of the plate with three degrees of freedom at each point: $w(\mathbf{x})$ corresponding to the mean transverse displacement of the plate, $\psi_1(\mathbf{x})$ and $\psi_2(\mathbf{x})$ describing the first branches of the thickness-shear vibration. The Lagrangian of Reissner-Mindlin's plate theory reads

$$L = \frac{1}{2}\rho h(w_{,t}^2 + \alpha h^2\psi_{1,t}^2 + \alpha h^2\psi_{2,t}^2) - \frac{1}{2}\mu h\left[\frac{h^2}{6}(\sigma\psi_{\alpha,\alpha}^2 + \psi_{(\alpha,\beta)}\psi_{(\alpha,\beta)}) + \alpha\pi^2(\psi_\alpha + w_{,\alpha})(\psi_\alpha + w_{,\alpha})\right],$$

where

$$\psi_{(\alpha,\beta)} = \frac{1}{2}(\psi_{\alpha,\beta} + \psi_{\beta,\alpha}), \quad \alpha = \frac{1}{2}\left(\frac{\pi^2}{24}\right)^2$$

and all other notations remain the same as for Kirchhoff's plate theory (see [31] for the derivation of this theory as well as many other shell and rod theories).

EXAMPLE 3.8. Acoustic vibrations (sound waves).

Small amplitude vibrations of ideal compressible fluids (or ideal gases) are governed by the equations of motion of these media linearized about their equilibrium state [8,45]. The velocity potential $\varphi(\mathbf{x})$ is regarded as the only generalized displacement, so in 3-D case we have $d = 3$ and $n = 1$. The Lagrangian reads

$$L = \frac{1}{2}\rho_0(\varphi_{,\alpha}\varphi_{,\alpha} - \frac{1}{c^2}\varphi_{,t}^2),$$

where ρ_0 is the equilibrium mass density and $c = \sqrt{\partial p / \partial \rho|_{\rho_0}}$ the speed of sound, with p being the pressure. The interesting feature of this Lagrangian is that its first term corresponds to the kinetic energy, while the second term describes the deviation of the internal energy density from that of the equilibrium state. However, the governing equation does not change if we change the sign of L and interpret the second term as the kinetic energy, while the first term as the potential energy.

EXAMPLE 3.9. Vibrations of a three-dimensional elastic body.

Vibrations of a three-dimensional elastic body are best described within the 3-D elasticity theory [33], for which $d = n = 3$. At each point \mathbf{x} of the body we have three displacements $u_\alpha(\mathbf{x})$, $\alpha = 1, 2, 3$. The Lagrangian reads

$$L = \frac{1}{2} \rho(\mathbf{x}) u_{\alpha,t} u_{\alpha,t} - \frac{1}{2} E_{\alpha\beta\gamma\delta}(\mathbf{x}) \varepsilon_{\alpha\beta} \varepsilon_{\gamma\delta},$$

where $\rho(\mathbf{x})$ is the mass density,

$$\varepsilon_{\alpha\beta} = \frac{1}{2} (u_{\alpha,\beta} + u_{\beta,\alpha})$$

are the components of the strain tensor and $E_{\alpha\beta\gamma\delta}(\mathbf{x})$ the elastic moduli. For homogeneous bodies ρ and $E_{\alpha\beta\gamma\delta}$ do not depend on \mathbf{x} .

EXAMPLE 3.10. Vibrations of a three-dimensional piezoelectric body.

Piezoelectric crystals and ceramics are widely used as sensors and actuators for the active vibration control [31, 42]. Their vibrations are described within the 3-D dynamic theory of piezoelectricity, for which $d = 3$ and $n = 4$. At each point \mathbf{x} of the body we have three displacements $u_\alpha(\mathbf{x})$, $\alpha = 1, 2, 3$ and the electric potential $\varphi(\mathbf{x})$. The Lagrangian reads

$$L = \frac{1}{2} \rho u_{\alpha,t} u_{\alpha,t} - \left(\frac{1}{2} c_{\alpha\beta\gamma\delta}^E \varepsilon_{\alpha\beta} \varepsilon_{\gamma\delta} - e_{\alpha\beta\gamma} \varepsilon_{\alpha\beta} E_\gamma - \frac{1}{2} \varepsilon_{\alpha\beta}^S E_\alpha E_\beta \right),$$

where

$$\varepsilon_{\alpha\beta} = \frac{1}{2} (u_{\alpha,\beta} + u_{\beta,\alpha}) \quad \text{and} \quad E_\alpha = -\varphi_{,\alpha}$$

are the components of the strain tensor and the electric field, respectively.

Let us derive the equations of motion from Hamilton's variational principle. To this end we calculate the variation of the action functional

$$\delta I = \int_{t_0}^{t_1} \int_V \left(\frac{\partial L}{\partial u_i} \delta u_i + \frac{\partial L}{\partial u_{i,\alpha}} \delta u_{i,\alpha} + \frac{\partial L}{\partial u_{i,t}} \delta u_{i,t} \right) dx dt.$$

As before we employ Einstein's summation convention according to which all terms with repeated indices will be summed up within their ranges. For example, the second term in the above equation reads

$$\frac{\partial L}{\partial u_{i,\alpha}} \delta u_{i,\alpha} = \sum_{i=1}^n \sum_{\alpha=1}^d \frac{\partial L}{\partial u_{i,\alpha}} \delta u_{i,\alpha}.$$

Integrating by parts over \mathbf{x} and t with the help of Gauss' theorem and using the initial and end conditions as well as the boundary conditions, we obtain

$$\delta I = \int_{t_0}^{t_1} \int_V \left(\frac{\partial L}{\partial u_i} - \frac{\partial}{\partial x_\alpha} \frac{\partial L}{\partial u_{i,\alpha}} - \frac{\partial}{\partial t} \frac{\partial L}{\partial u_{i,t}} \right) \delta u_i dx dt = 0.$$

Since δu_i can be chosen independently and arbitrarily inside the region $V \times (t_0, t_1)$, the variational equation implies Euler-Lagrange's equations

$$\frac{\partial}{\partial t} \frac{\partial L}{\partial u_{i,t}} + \frac{\partial}{\partial x_\alpha} \frac{\partial L}{\partial u_{i,\alpha}} - \frac{\partial L}{\partial u_i} = 0, \quad i = 1, \dots, n. \quad (3.51)$$

These equations are subject to the kinematic boundary conditions (3.49) for the fixed boundary. For the free boundary δu_i may vary arbitrarily at ∂V , so the natural boundary conditions

$$\frac{\partial L}{\partial u_{i,\alpha}} v_\alpha = 0 \quad \text{at } \partial V, \quad i = 1, \dots, n,$$

must be used instead.

Thus, the motion of any conservative mechanical system is governed by a single function, the Lagrangian, which is of the form

$$L(\mathbf{x}, u_i, u_{i,\alpha}, u_{i,t}) = K(\mathbf{x}, u_{i,t}) - U(\mathbf{x}, u_i, u_{i,\alpha}),$$

where $K(\mathbf{x}, u_{i,t})$ is the kinetic energy density and $U(\mathbf{x}, u_i, u_{i,\alpha})$ the internal energy density. The kinetic energy density $K(\mathbf{x}, u_{i,t})$ is a positive definite quadratic form with respect to $u_{i,t}$

$$K(\mathbf{x}, u_{i,t}) = \frac{1}{2} \rho_{ij}(\mathbf{x}) u_{i,t} u_{j,t}, \quad (3.52)$$

where $\rho_{ij}(\mathbf{x})$ is $n \times n$ symmetric matrix called a mass density matrix. Thus,

$$\frac{\partial K}{\partial u_{i,t}} u_{i,t} = 2K(u_{i,t}),$$

showing that K is a homogeneous function of order two with respect to $u_{i,t}$. We now prove that the conservation of energy follows from equations (3.51). Indeed, multiplying (3.51) with $u_{i,t}$ and integrating over V , we obtain

$$\int_V \left(\frac{\partial}{\partial t} \frac{\partial K}{\partial u_{i,t}} u_{i,t} + \frac{\partial}{\partial x_\alpha} \frac{\partial L}{\partial u_{i,\alpha}} u_{i,t} - \frac{\partial L}{\partial u_i} u_{i,t} \right) dx = 0.$$

Integrating the second term by parts using the boundary conditions and keeping in mind the property of K , we get

$$\int_V \left[\frac{\partial}{\partial t} (2K) - \frac{\partial L}{\partial u_{i,t}} u_{i,tt} - \frac{\partial L}{\partial u_{i,\alpha}} u_{i,\alpha t} - \frac{\partial L}{\partial u_i} u_{i,t} \right] dx = 0.$$

The last three terms in the integrand give $-\partial L/\partial t$. Thus,

$$\frac{d}{dt} E = \frac{d}{dt} \int_V (K + U) dx = 0,$$

and the total energy E is conserved.

For small vibrations we may assume that both u_i and $u_{i,\alpha}$ are small and present the internal energy density U as the quadratic form

$$U(\mathbf{x}, u_i, u_{i,\alpha}) = \frac{1}{2} E_{i\alpha j\beta}(\mathbf{x}) u_{i,\alpha} u_{j,\beta} + \frac{1}{2} A_{ij}(\mathbf{x}) (u_i - B_\alpha(\mathbf{x}) u_{i,\alpha}) (u_j - B_\beta(\mathbf{x}) u_{j,\beta}). \quad (3.53)$$

The examples considered above show that the internal energy density $U(\mathbf{x}, u_i, u_{i,\alpha})$ must be non-negative definite⁴ with respect to its arguments u_i and $u_{i,\alpha}$, but not necessarily positive definite. The internal energy density may vanish for example at rigid-body motions if the boundary conditions admit such motions. Concerning the coefficients of this quadratic form we require the following symmetry properties

$$A_{ij}(\mathbf{x}) = A_{ji}(\mathbf{x}), \quad E_{i\alpha j\beta}(\mathbf{x}) = E_{j\beta i\alpha}(\mathbf{x}).$$

Taking these symmetry properties into account, we get for the partial derivatives of the Lagrangian with respect to u_i and $u_{i,\alpha}$ the following formulas

$$\begin{aligned} \frac{\partial L}{\partial u_i} &= -\frac{\partial U}{\partial u_i} = -A_{ij}(u_j - B_\beta u_{j,\beta}), \\ \frac{\partial L}{\partial u_{i,\alpha}} &= -\frac{\partial U}{\partial u_{i,\alpha}} = -E_{i\alpha j\beta} u_{j,\beta} + A_{ij} B_\alpha (u_j - B_\beta u_{j,\beta}), \end{aligned}$$

where the argument \mathbf{x} of the coefficients is suppressed for short. Substituting these formulas into Euler-Lagrange's equations, we obtain the equations of motion

$$\rho_{ij} u_{j,tt} - (E_{i\alpha j\beta} u_{j,\beta})_{,\alpha} + (A_{ij} B_\alpha (u_j - B_\beta u_{j,\beta}))_{,\alpha} + A_{ij} (u_j - B_\beta u_{j,\beta}) = 0.$$

These equations can be presented also in the operator form as follows

$$\mathbf{M} \mathbf{u}_{,tt} + \mathbf{K} \mathbf{u} = \mathbf{0}, \quad (3.54)$$

where \mathbf{M} is the mass density matrix and \mathbf{K} the differential operator, called a stiffness operator, which maps the vector-valued function $\mathbf{u}(\mathbf{x}, t)$ (having n components) into the vector-valued function according to

⁴ Except piezoelectric bodies considered in example 3.10 where U represents the electric enthalpy. Using Legendre transformation we can obtain the non-negative definite internal energy in terms of the strain tensor and the electric induction field [31].

$$(\mathbf{K}\mathbf{u})_i = -(E_{i\alpha j\beta}u_{j,\beta})_{,\alpha} + (A_{ij}B_{\alpha}(u_j - B_{\beta}u_{j,\beta}))_{,\alpha} + A_{ij}(u_j - B_{\beta}u_{j,\beta}).$$

We have to find the solution of (3.54) satisfying the initial conditions

$$\mathbf{u}(\mathbf{x}, 0) = \mathbf{u}_0(\mathbf{x}), \quad \mathbf{u}_{,t}(\mathbf{x}, 0) = \mathbf{v}_0(\mathbf{x}). \quad (3.55)$$

and the boundary conditions (3.49) (or the natural boundary conditions for the free boundary).

Solution. We seek a particular solution of (3.54) in the form

$$\mathbf{u}(\mathbf{x}, t) = \mathbf{q}(\mathbf{x})w(t).$$

Separating the variables \mathbf{x} and t as usual, we arrive at the eigenvalue problem

$$(\mathbf{K} - \lambda\mathbf{M})\mathbf{q} = \mathbf{0}, \quad (3.56)$$

subject to the boundary condition

$$\mathbf{q} = \mathbf{0} \quad \text{at } \mathbf{x} \in \partial V,$$

where $\lambda = \omega^2$, ω being the eigenfrequency. It turns out that all eigenvalues are real and non-negative. Indeed, if λ is an eigenvalue and $\mathbf{q}(\mathbf{x})$ a corresponding eigenfunction, then, by taking the scalar product of (3.56) with $\mathbf{q}(\mathbf{x})$ we have

$$\langle \mathbf{q}, \mathbf{K}\mathbf{q} \rangle - \lambda \langle \mathbf{q}, \mathbf{M}\mathbf{q} \rangle = 0.$$

Here and in what follows the scalar product between two vector-valued functions $\mathbf{u}(\mathbf{x})$ and $\mathbf{v}(\mathbf{x})$ is defined by

$$\langle \mathbf{u}, \mathbf{v} \rangle \equiv \int_V u_i(\mathbf{x})v_i(\mathbf{x})dx.$$

Thus,

$$\lambda = \frac{\langle \mathbf{q}, \mathbf{K}\mathbf{q} \rangle}{\langle \mathbf{q}, \mathbf{M}\mathbf{q} \rangle}.$$

The numerator can be transformed by the integration by parts using the boundary conditions giving

$$\begin{aligned} \langle \mathbf{q}, \mathbf{K}\mathbf{q} \rangle &= \int_V q_i [-(E_{i\alpha j\beta}q_{j,\beta})_{,\alpha} + (A_{ij}B_{\alpha}(q_j - B_{\beta}q_{j,\beta}))_{,\alpha} + A_{ij}(q_j - B_{\beta}q_{j,\beta})] dx \\ &= \int_V [E_{i\alpha j\beta}q_{i,\alpha}q_{j,\beta} + A_{ij}(q_i - B_{\alpha}q_{i,\alpha})(q_j - B_{\beta}q_{j,\beta})] dx = 2 \int_V U(\mathbf{x}, q_i, q_{i,\alpha}) dx, \end{aligned}$$

so $\langle \mathbf{q}, \mathbf{K}\mathbf{q} \rangle \geq 0$. Since the denominator $\langle \mathbf{q}, \mathbf{M}\mathbf{q} \rangle = 2 \int_V K(\mathbf{x}, q_i) dx$ is positive, the eigenvalue λ is non-negative. The expression for λ is Rayleigh's quotient, for which extremal properties of eigenfrequencies of a continuous oscillator can be established (see exercise 3.11).

Note that the stiffness operator \mathbf{K} is self-adjoint in the following sense: for arbitrary two functions $\mathbf{u}(x)$ and $\mathbf{v}(x)$

$$\langle \mathbf{u}, \mathbf{K}\mathbf{v} \rangle = \langle \mathbf{v}, \mathbf{K}\mathbf{u} \rangle.$$

Indeed, integrating the expression on the left-hand side by parts using the boundary conditions and the symmetry properties of $A_{ij}(\mathbf{x})$ and $E_{i\alpha j\beta}(\mathbf{x})$, we have

$$\begin{aligned} \langle \mathbf{u}, \mathbf{K}\mathbf{v} \rangle &= \int_V u_i [-(E_{i\alpha j\beta} v_{j,\beta})_{,\alpha} + (A_{ij} B_\alpha (v_j - B_\beta v_{j,\beta}))_{,\alpha} + A_{ij} (v_j - B_\beta v_{j,\beta})] dx \\ &= \int_V [E_{i\alpha j\beta} u_{i,\alpha} v_{j,\beta} + A_{ij} (u_i - B_\alpha u_{i,\alpha}) (v_j - B_\beta v_{j,\beta})] dx \\ &= \int_V v_i [-(E_{i\alpha j\beta} u_{j,\beta})_{,\alpha} + (A_{ij} B_\alpha (u_j - B_\beta u_{j,\beta}))_{,\alpha} + A_{ij} (u_j - B_\beta u_{j,\beta})] dx, \end{aligned}$$

and thus $\langle \mathbf{u}, \mathbf{K}\mathbf{v} \rangle = \langle \mathbf{v}, \mathbf{K}\mathbf{u} \rangle$. The self-adjointness of \mathbf{K} implies the following orthogonality property: two eigenfunctions $\mathbf{q}_1, \mathbf{q}_2$ corresponding to two different eigenvalues $\lambda_1 \neq \lambda_2$ are orthogonal in the following sense

$$\langle \mathbf{q}_1, \mathbf{M}\mathbf{q}_2 \rangle = 0, \quad \langle \mathbf{q}_1, \mathbf{K}\mathbf{q}_2 \rangle = 0.$$

To show this we multiply equation (3.56) for λ_1 with \mathbf{q}_2 to get

$$\langle \mathbf{q}_2, \mathbf{K}\mathbf{q}_1 \rangle = \lambda_1 \langle \mathbf{q}_2, \mathbf{M}\mathbf{q}_1 \rangle.$$

Similar procedure applied to the equation for λ_2 gives

$$\langle \mathbf{q}_1, \mathbf{K}\mathbf{q}_2 \rangle = \lambda_2 \langle \mathbf{q}_1, \mathbf{M}\mathbf{q}_2 \rangle.$$

Subtracting these equations from each other and using the symmetry of \mathbf{M} and the self-adjointness of \mathbf{K} , we obtain

$$(\lambda_1 - \lambda_2) \langle \mathbf{q}_1, \mathbf{M}\mathbf{q}_2 \rangle = 0,$$

which implies the orthogonality. We choose the following normalization condition for the eigenfunctions

$$\langle \mathbf{q}_j, \mathbf{M}\mathbf{q}_j \rangle = 1.$$

Provided the region V is compact and the operator \mathbf{K} is self-adjoint and non-negative definite, one can show that the problem (3.56) has a countable set of eigenvalues

$$0 \leq \lambda_1 \leq \lambda_2 \leq \dots, \quad \lim_{j \rightarrow \infty} \lambda_j = +\infty,$$

called a spectrum of the continuous oscillator. Based on this result we can now solve the initial boundary-value problem by combining the eigenfunctions with the solutions for $w_j(t)$

$$w_j(t) = a_j \cos \omega_j t + b_j \sin \omega_j t$$

to present the general solution of (3.54) in form of the series

$$\mathbf{u}(\mathbf{x}, t) = \sum_{j=1}^{\infty} \mathbf{q}_j(\mathbf{x})(a_j \cos \omega_j t + b_j \sin \omega_j t).$$

The initial conditions (3.55) lead to

$$\sum_{j=1}^{\infty} a_j \mathbf{q}_j(\mathbf{x}) = \mathbf{u}_0(\mathbf{x}), \quad \sum_{j=1}^{\infty} b_j \omega_j \mathbf{q}_j(\mathbf{x}) = \mathbf{v}_0(\mathbf{x}).$$

Multiplying these equations with $\mathbf{M}\mathbf{q}_i$ and making use of the orthogonality and normalization conditions, we get

$$a_i = \langle \mathbf{u}_0, \mathbf{M}\mathbf{q}_i \rangle, \quad b_i = \frac{1}{\omega_i} \langle \mathbf{v}_0, \mathbf{M}\mathbf{q}_i \rangle.$$

For the compact region V one can prove that the eigenfunctions form an orthogonal basis in the space of continuous and piecewise continuously differentiable functions (see, e.g., [12]) and the Fourier series converges uniformly to the solution if its initial data \mathbf{u}_0 and \mathbf{v}_0 belong to this function space.

Dissipative Systems. For dissipative continuous oscillators the following variational principle holds true: among all admissible motions of an arbitrary dissipative system constrained by the initial and end conditions

$$\mathbf{u}(\mathbf{x}, t_0) = \mathbf{u}_0(\mathbf{x}), \quad \mathbf{u}(\mathbf{x}, t_1) = \mathbf{u}_1(\mathbf{x}),$$

as well as the boundary conditions (3.49), the true motion satisfies the variational equation

$$\delta \int_{t_0}^{t_1} \int_V L(\mathbf{x}, \mathbf{u}, \mathbf{u}_{,\alpha}, \mathbf{u}_{,t}) dx dt - \int_{t_0}^{t_1} \int_V \left(\frac{\partial D}{\partial u_{i,t}} \delta u_i + \frac{\partial D}{\partial u_{i,\alpha}} \delta u_{i,\alpha} \right) dx dt = 0. \quad (3.57)$$

Here $D(\mathbf{x}, u_{i,t}, u_{i,\alpha})$ is the dissipation function. Calculation of variation in exactly the same manner as in the previous case leads to

$$\int_{t_0}^{t_1} \int_V \left(\frac{\partial L}{\partial u_i} - \frac{\partial}{\partial x_\alpha} \frac{\partial L}{\partial u_{i,\alpha}} - \frac{\partial}{\partial t} \frac{\partial L}{\partial u_{i,t}} - \frac{\partial D}{\partial u_{i,t}} + \frac{\partial}{\partial x_\alpha} \frac{\partial D}{\partial u_{i,\alpha}} \right) \delta u_i dx dt = 0.$$

Due to the arbitrariness of δu_i inside the region $V \times (t_0, t_1)$ the following equations are obtained

$$\frac{\partial}{\partial t} \frac{\partial L}{\partial u_{i,t}} + \frac{\partial}{\partial x_\alpha} \frac{\partial L}{\partial u_{i,\alpha}} - \frac{\partial L}{\partial u_i} + \frac{\partial D}{\partial u_{i,t}} - \frac{\partial}{\partial x_\alpha} \frac{\partial D}{\partial u_{i,\alpha}} = 0, \quad i = 1, \dots, n.$$

These equations are subject to the kinematic boundary conditions (3.49) for the fixed boundary. For the free boundary the natural boundary conditions

$$\left(\frac{\partial L}{\partial u_{i,\alpha}} - \frac{\partial D}{\partial u_{i,\alpha t}} \right) v_\alpha = 0 \quad \text{at } \partial V, \quad i = 1, \dots, n,$$

must be used instead.

Thus, the motion of continuous dissipative mechanical systems is governed by two functions, the Lagrangian and the dissipation function. We take the Lagrangian in the form

$$L(\mathbf{x}, u_i, u_{i,\alpha}, u_{i,t}) = K(\mathbf{x}, u_{i,t}) - U(\mathbf{x}, u_i, u_{i,\alpha}),$$

where the kinetic and potential energy densities are given by (3.52) and (3.53), respectively. Concerning the dissipation function the most simple assumption is that of proportional damping, for which

$$D(\mathbf{x}, u_{i,t}, u_{i,\alpha t}) = \alpha K(\mathbf{x}, u_{i,t}) + \beta U(\mathbf{x}, u_{i,t}, u_{i,\alpha t}),$$

with α and β being two constants. The first term in the right-hand side of this equation is thought of as the external damping due to the resistance to motion by the surrounding medium (say, the air resistance), while its second term is normally referred to as the internal damping which must be proportional to the relative motion of parts of the system. In this case, it is easy to show that the equation of motion can be presented in the form

$$\mathbf{M}\mathbf{u}_{,tt} + \mathbf{C}\mathbf{u}_{,t} + \mathbf{K}\mathbf{u} = \mathbf{0}, \quad (3.58)$$

where \mathbf{M} is the mass density matrix and \mathbf{K} the stiffness operator obtained previously. The operator \mathbf{C} , called a damping operator, is given by

$$\mathbf{C} = \alpha\mathbf{M} + \beta\mathbf{K}.$$

Equation (3.58) is subject to the boundary conditions (3.49) and the initial conditions (3.55).

Solution. We seek a particular solution of (3.58) in the form

$$\mathbf{u}(\mathbf{x}, t) = \mathbf{q}_j(\mathbf{x})w_j(t),$$

where $\mathbf{q}_j(\mathbf{x})$ is an eigenvector found from the eigenvalue problem (3.56) and $w_j(t)$ an unknown scalar function. Substituting this Ansatz into (3.58) and taking into account the proportionality property, we reduce this equation to

$$\mathbf{M}\mathbf{q}_j[\ddot{w}_j + (\alpha + \beta\omega_j^2)\dot{w}_j + \omega_j^2 w_j] = \mathbf{0}.$$

Since $\mathbf{M}\mathbf{q}_j \neq \mathbf{0}$, the expression in the square brackets must vanish giving

$$\ddot{w}_j + (\alpha + \beta\omega_j^2)\dot{w}_j + \omega_j^2 w_j = 0.$$

This ordinary differential equation can be solved by the method discussed in Section 1.2. The general solution of (3.58) is obtained as the linear superposition of these particular solutions. Thus, the problem reduces to solving a countable set of uncoupled differential equations. Since the damping coefficients of these equations increase with the frequencies, the amplitudes of high frequency modes decay much faster than those of low-frequency modes. Thus, the truncation of the mass, stiffness, and damping matrices makes sense and its error can be controlled if α and β are known.

3.7 Exercises

EXERCISE 3.1. Derive the equations of motion for an infinite chain of atoms, where each atom interacts with m nearest neighbors on the left as well as m nearest neighbors on the right. Show the transition to the continuum.

Solution. Let u_j be the displacements of atoms from their equilibrium positions. Then the kinetic energy of this chain reads

$$K(\dot{u}) = \frac{1}{2} m \sum_j \dot{u}_j^2.$$

The potential energy of the springs is

$$U(u) = \frac{1}{2} \sum_j \sum_{\alpha=1}^m k_\alpha (u_j - u_{j-\alpha})^2.$$

Lagrange's equations of this chain lead to

$$m\ddot{u}_j + \sum_{\alpha=1}^m [k_\alpha (u_j - u_{j-\alpha}) - k_\alpha (u_{j+\alpha} - u_j)] = 0.$$

We can represent these equations in the equivalent quasi-continuum form by using the one-to-one correspondence between functions of discrete and continuous arguments

$$u(x) = b \sum_j u(jb) \delta_B(x - jb),$$

where b is the lattice constant. As shown in Section 3.1, the kinetic energy of the chain becomes

$$K(u, \dot{u}) = \int \frac{1}{2} \mu \dot{u}_x^2 dx,$$

where $\mu = m/b$. Let us rewrite the potential energy of the discrete chain in the form

$$U(u) = \frac{1}{2} \sum_{j,l} u_j \Phi(j-l) u_l,$$

where $\Phi(-j) = \Phi(j)$ and

$$\Phi(0) = 2 \sum_{\alpha=1}^m k_{\alpha}, \quad \Phi(j) = -k_j \quad \text{for } 0 < j \leq m, \quad \Phi(j) = 0 \quad \text{for } |j| > m.$$

In terms of $u(x)$ the potential energy is given by

$$U(u) = \frac{1}{2} \int_{-\infty}^{\infty} \int_{-\infty}^{\infty} u(x) \Phi(x-y) u(y) dx dy,$$

where

$$\Phi(x) = \frac{1}{2\pi} \int_{-\infty}^{\infty} \Phi(k) e^{ikx} dk,$$

and

$$\Phi(k) = \frac{1}{b} \sum_{|j| \leq m} \Phi(j) e^{-ijbk}, \quad k \in B.$$

Thus, the action functional can be presented in terms of the function $u(x, t)$ as follows

$$I[u(x, t)] = \int_{t_0}^{t_1} dt \int_{-\infty}^{\infty} \left[\frac{1}{2} \mu u_t^2 - \frac{1}{2} \int_{-\infty}^{\infty} u(x, t) \Phi(x-y) u(y, t) dy \right] dx.$$

Varying this action functional, we obtain the integral equation

$$\mu u_{,tt} + \int_{-\infty}^{\infty} \Phi(x-y) u(y, t) dy = 0.$$

The continuum limit can be obtained by approximating function $\Phi(k)$ in the long wave range $|k| \ll 1$:

$$\Phi(k) = \frac{2}{b} \sum_{\alpha=1}^m k_{\alpha} (1 - \cos \alpha bk) \approx \sum_{\alpha=1}^m \frac{k_{\alpha} \alpha^2}{b} (bk)^2.$$

With this approximation the equation of motion reduces to

$$\mu u_{,tt} - S u_{,xx} = 0,$$

where $S = b \sum_{\alpha=1}^m k_{\alpha} \alpha^2$.

EXERCISE 3.2. A string of length l is released from a position shown in Fig. 3.14. Determine its motion.

Solution. The initial conditions of the string are

$$w(x, 0) = w_0(x) = \begin{cases} \frac{w_0}{a} x & \text{for } x < a, \\ \frac{w_0}{a-l} (x-l) & \text{otherwise,} \end{cases} \quad w_{,t}(x, 0) = 0.$$

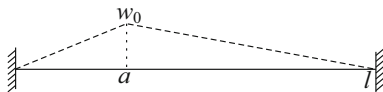

Fig. 3.14 Initial position of string

The solution to the equation of motion $w_{,tt} = c^2 w_{,xx}$ satisfying the boundary conditions $w(0,t) = w(l,t) = 0$ reads

$$w(x,t) = \sqrt{\frac{2}{l}} \sum_{j=1}^{\infty} \sin \frac{j\pi}{l} x (a_j \cos \omega_j t + b_j \sin \omega_j t),$$

where $\omega_j = j \frac{\pi c}{l}$. The initial conditions yield

$$\begin{aligned} \sqrt{\frac{2}{l}} \sum_{j=1}^{\infty} a_j \sin \frac{j\pi}{l} x &= w_0(x), \\ \sqrt{\frac{2}{l}} \sum_{j=1}^{\infty} \omega_j b_j \sin \frac{j\pi}{l} x &= v_0(x) = 0. \end{aligned}$$

Thus, the coefficients b_j vanish. To determine the coefficients a_j , we use the orthogonality and normalization conditions to get

$$\begin{aligned} a_j &= \sqrt{\frac{2}{l}} \int_0^l w_0(x) \sin \frac{j\pi}{l} x dx \\ &= \sqrt{\frac{2}{l}} \left[\int_0^a \frac{w_0}{a} x \sin \frac{j\pi}{l} x dx + \int_a^l \frac{w_0}{a-l} (x-l) \sin \frac{j\pi}{l} x dx \right] \\ &= \sqrt{\frac{2}{l}} \left[\frac{l w_0 \left(l \sin \left(\frac{\pi a j}{l} \right) - \pi a j \cos \left(\frac{\pi a j}{l} \right) \right)}{\pi^2 a j^2} \right. \\ &\quad \left. + \frac{l w_0 \left(l \left(\sin(\pi j) - \sin \left(\frac{\pi a j}{l} \right) \right) + \pi j (a-l) \cos \left(\frac{\pi a j}{l} \right) \right)}{\pi^2 j^2 (a-l)} \right] \\ &= \sqrt{\frac{2}{l}} \frac{l^3 w_0 \sin \left(\frac{\pi a j}{l} \right)}{\pi^2 j^2 a (l-a)}. \end{aligned}$$

Finally, the solution takes the form

$$w(x,t) = \sum_{j=1}^{\infty} \frac{2l^2 w_0 \sin \left(\frac{\pi a j}{l} \right)}{\pi^2 j^2 a (l-a)} \sin \frac{j\pi}{l} x \cos j \frac{\pi c}{l} t.$$

EXERCISE 3.3. An elastic bar of length l has its free end stretched uniformly so that its length becomes $l + u_0$, and then is released from that position (see Fig. 3.15). Determine its motion.



Fig. 3.15 Uniformly stretched bar

Solution. Let $u(x, t)$ be the longitudinal displacement of the bar. The equation of longitudinal vibration of the bar reads

$$u_{,tt} = c^2 u_{,xx}.$$

This equation is subject to the boundary conditions

$$u(0, t) = 0, \quad u_{,x}(l, t) = 0.$$

The last condition is the traction free boundary condition.

Let us first find the particular solutions by separating the variables with the Ansatz $u(x, t) = q(x)p(t)$. It is easy to show that $q(x)$ satisfies the equation

$$q'' + \left(\frac{\omega}{c}\right)^2 q = 0$$

and the boundary conditions

$$q(0) = 0, \quad q'(l) = 0.$$

The solution reads

$$q(x) = A \cos \frac{\omega}{c} x + B \sin \frac{\omega}{c} x.$$

The first boundary condition implies that $A = 0$. From the second boundary condition we get

$$\cos \frac{\omega}{c} l = 0 \quad \Rightarrow \quad \omega = \omega_j = (2j - 1) \frac{\pi c}{2l}, \quad j = 1, 2, \dots$$

As the normalization condition we choose again

$$\int_0^l q_j^2(x) dx = 1 \quad \Rightarrow \quad q_j(x) = \sqrt{\frac{2}{l}} \sin \frac{(2j - 1)\pi}{2l} x.$$

Combining this with the solution for $p(t)$

$$p(t) = a_j \cos \omega_j t + b_j \sin \omega_j t,$$

we represent the general solution in form of the Fourier series

$$u(x,t) = \sqrt{\frac{2}{l}} \sum_{j=1}^{\infty} \sin \frac{(2j-1)\pi}{2l} x (a_j \cos \omega_j t + b_j \sin \omega_j t).$$

The initial conditions of the bar

$$u(x,0) = u_0(x) = \frac{u_0}{l} x, \quad u_t(x,0) = 0,$$

yield

$$\begin{aligned} \sqrt{\frac{2}{l}} \sum_{j=1}^{\infty} a_j \sin \frac{(2j-1)\pi}{2l} x &= u_0(x), \\ \sqrt{\frac{2}{l}} \sum_{j=1}^{\infty} \omega_j b_j \sin \frac{(2j-1)\pi}{2l} x &= v_0(x) = 0. \end{aligned}$$

Thus, the coefficients b_j vanish. To determine the coefficients a_j we use the orthogonality and normalization conditions to get

$$a_j = \sqrt{\frac{2}{l}} \int_0^l \frac{u_0}{l} x \sin \frac{(2j-1)\pi}{2l} x dx = \sqrt{\frac{2}{l}} \frac{4lu_0(-1)^{j+1}}{\pi^2(2j-1)^2}.$$

Finally, the solution takes the form

$$u(x,t) = \sum_{j=1}^{\infty} \frac{8u_0(-1)^{j+1}}{\pi^2(2j-1)^2} \sin \frac{(2j-1)\pi}{2l} x \cos(2j-1) \frac{\pi c}{2l} t.$$

EXERCISE 3.4. An elastic shaft having a rigid disk attached at its free end performs torsional vibrations. The disk has a moment of inertia J_D (see Fig. 3.16). Derive the equation of small vibrations and the boundary conditions from Hamilton’s variational principle. Determine the eigenfrequencies.

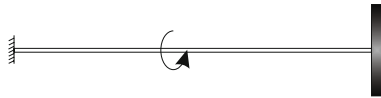

Fig. 3.16 Shaft with rigid disk attached at its end

Solution. We write down the action functional of this system

$$I[\varphi(x,t)] = \int_{t_0}^{t_1} \int_0^l \left(\frac{1}{2} \rho J_p \varphi_x^2 - \frac{1}{2} G J_p \varphi_x^2 \right) dx dt + \int_{t_0}^{t_1} \frac{1}{2} J_D \varphi_t(l,t)^2 dt.$$

The last term corresponds to the action functional of the disk. Varying this action functional, we have

$$\begin{aligned} \delta I &= \int_{t_0}^{t_1} \int_0^l (\rho J_p \varphi_{,t} \delta \varphi_{,t} - G J_p \varphi_{,x} \delta \varphi_{,x}) dx dt + \int_{t_0}^{t_1} J_D \varphi_{,t}(l,t) \delta \varphi_{,t}(l,t) dt \\ &= \int_{t_0}^{t_1} \int_0^l (-\rho J_p \varphi_{,tt} + G J_p \varphi_{,xx}) \delta \varphi dx dt - \int_{t_0}^{t_1} (G J_p \varphi_{,x} + J_D \varphi_{,t}) \delta \varphi \Big|_{x=l} dt = 0. \end{aligned}$$

Since $\delta \varphi$ can be chosen arbitrarily in the interval $(0, l)$ and at the end point $x = l$, this equation implies that

$$\rho J_p \varphi_{,tt} - G J_p \varphi_{,xx} = 0 \quad \Rightarrow \quad \varphi_{,tt} - c^2 \varphi_{,xx} = 0$$

inside $(0, l)$, with $c^2 = G/\rho$, and

$$G J_p \varphi_{,x} + J_D \varphi_{,t} = 0$$

at $x = l$. Together with the boundary condition at $x = 0$

$$\varphi(0, t) = 0,$$

these constitute the eigenvalue problem. To determine the spectrum of this system we seek for the solution in the form

$$\varphi(x, t) = q(x) e^{i\omega t}.$$

Substituting this Ansatz into the equation of motion and the boundary conditions, we obtain

$$\omega^2 q + c^2 q'' = 0,$$

and

$$q(0) = 0, \quad G J_p q'(l) - J_D \omega^2 q(l) = 0.$$

From the equation for $q(x)$ we find that

$$q(x) = A \cos \frac{\omega}{c} x + B \sin \frac{\omega}{c} x.$$

The boundary condition $q(0) = 0$ yields $A = 0$. The other boundary condition at $x = l$ leads to the transcendental equation to determine the eigenfrequencies

$$G J_p \frac{\omega}{c} \cos \frac{\omega}{c} l - J_D \omega^2 \sin \frac{\omega}{c} l = 0,$$

or

$$\tan \frac{\omega}{c} l = \frac{G J_p}{J_D} \frac{1}{\omega c}.$$

EXERCISE 3.5. Find the eigenfrequencies of flexural vibrations of a beam with one clamped edge and one free edge. Plot the shapes of the first three modes of vibrations.

Solution. For the beam with one clamped edge at $x = 0$ and one free edge at $x = l$ the boundary conditions read

$$w(0,t) = w_{,x}(0,t) = 0, \quad w_{,xx}(l,t) = w_{,xxx}(l,t) = 0.$$

The standard separation of variables leads to the following eigenvalue problem

$$q'''' - \kappa^4 q = 0,$$

with $\kappa^4 = \omega^2 \mu / EJ$, together with the boundary conditions

$$q(0) = q'(0) = 0, \quad q''(l) = q'''(l) = 0.$$

The solution reads

$$q(x) = C_1 \sin \kappa x + C_2 \cos \kappa x + C_3 \sinh \kappa x + C_4 \cosh \kappa x.$$

Substituting this solution into the boundary conditions, we obtain

$$\begin{pmatrix} 0 & 1 & 0 & 1 \\ 1 & 0 & 1 & 0 \\ -\sin \lambda & -\cos \lambda & \sinh \lambda & \cosh \lambda \\ -\cos \lambda & \sin \lambda & \cosh \lambda & \sinh \lambda \end{pmatrix} \begin{pmatrix} C_1 \\ C_2 \\ C_3 \\ C_4 \end{pmatrix} = \begin{pmatrix} 0 \\ 0 \\ 0 \\ 0 \end{pmatrix},$$

where $\lambda = \kappa l$. The non-trivial solution exists if the determinant of the matrix vanishes giving

$$1 + \cos \lambda \cosh \lambda = 0.$$

The first three roots of this equation are

$$\lambda_1 = 1.8751, \quad \lambda_2 = 4.6941, \quad \lambda_3 = 7.8548.$$

The roots λ_j with $j > 3$ are approximately given by $(2j - 1)\pi/2$. The shapes of the first three modes of vibrations are plotted in Fig. 3.17.

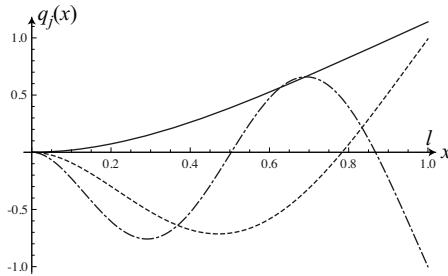

Fig. 3.17 Three first eigenfunctions

EXERCISE 3.6. The beam of length l and mass m sketched in Fig. 3.18 is released and latches upon impact onto the support B. Provided there is no rebound and no

loss of energy, determine the flexural vibration of the beam after impact. How to proceed if there is a rebound?

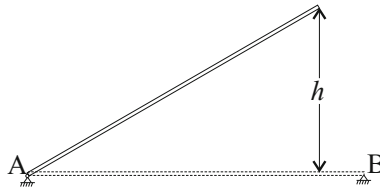

Fig. 3.18 Falling beam

Solution. Before impact the beam experiences a free falling. The conservation of energy yields

$$\frac{1}{2}J_A\dot{\phi}_0^2 = mg\frac{h}{2},$$

where $\dot{\phi}_0$ is the angular velocity of the beam immediately before impact, and

$$J_A = J_S + m(l/2)^2 = m\frac{l^2}{12} + m\frac{l^2}{4} = m\frac{l^2}{3}$$

is the moment of inertia of the beam about A. Thus, the angular velocity $\dot{\phi}_0$ is equal to

$$\dot{\phi}_0 = \sqrt{\frac{3gh}{l^2}}.$$

Knowing this angular velocity before impact, we find the initial conditions of the beam upon impact

$$w(x, 0) = w_0(x) = 0, \quad w_t(x, 0) = \dot{\phi}_0 x.$$

The solution to the equation of motion $\mu w_{,tt} = EJw_{,xxxx}$ satisfying the simply supported boundary conditions reads

$$w(x, t) = \sqrt{\frac{2}{l}} \sum_{j=1}^{\infty} \sin \frac{j\pi}{l} x (a_j \cos \omega_j t + b_j \sin \omega_j t),$$

where $\omega_j = (j\pi)^2 \sqrt{\frac{EJ}{\mu l^4}}$. The initial conditions yield

$$\begin{aligned} \sqrt{\frac{2}{l}} \sum_{j=1}^{\infty} a_j \sin \frac{j\pi}{l} x &= 0, \\ \sqrt{\frac{2}{l}} \sum_{j=1}^{\infty} \omega_j b_j \sin \frac{j\pi}{l} x &= v_0(x) = \dot{\phi}_0 x. \end{aligned}$$

Thus, the coefficients a_j vanish. To determine the coefficients b_j we use the orthogonality and normalization condition to get

$$b_j = \frac{1}{\omega_j} \sqrt{\frac{2}{l}} \int_0^l \phi_0 x \sin \frac{j\pi}{l} x dx = \frac{1}{\omega_j} \sqrt{\frac{2}{l}} \frac{\phi_0 l^2 (-1)^{j+1}}{\pi j}.$$

Finally, the solution takes the form

$$w(x,t) = \sum_{j=1}^{\infty} \frac{2\phi_0 l (-1)^{j+1}}{\omega_j \pi j} \sin \frac{j\pi}{l} x \sin \omega_j t.$$

In case of rebound the simply supported boundary conditions at $x = l$ should be replaced by the free boundary conditions

$$w_{,xx}(l,t) = w_{,xxx}(l,t) = 0,$$

while the initial conditions are obtained from the previous solution by the continuity of displacement and velocity.

EXERCISE 3.7. Derive the boundary conditions for a beam connected with a spring shown in Fig. 3.19. Find the eigenfrequencies.

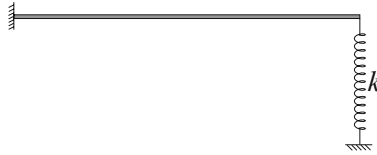

Fig. 3.19 Beam with spring

Solution. To derive the boundary conditions we write down the action functional

$$I[w(x,t)] = \int_{t_0}^{t_1} \int_0^l \left[\frac{1}{2} \mu w_{,t}^2 - \frac{1}{2} EJ (w_{,xx})^2 \right] dx dt - \int_{t_0}^{t_1} \frac{1}{2} k (w(l,t))^2 dt,$$

where the last term is associated with the potential energy of the spring. Varying this action functional, we obtain

$$\delta I = \int_{t_0}^{t_1} \int_0^l (\mu w_{,t} \delta w_{,t} - EJ w_{,xx} \delta w_{,xx}) dx dt - \int_{t_0}^{t_1} k w(l,t) \delta w(l,t) dt.$$

Integrating the first two terms by parts and using the initial and end conditions as well as the kinematic boundary conditions at $x = 0$

$$w(0,t) = w_{,x}(0,t) = 0,$$

we reduce the first variation to

$$\delta I = \int_{t_0}^{t_1} \int_0^l (-\mu w_{,tt} - EJw_{,xxxx}) \delta w dx dt - \int_{t_0}^{t_1} EJw_{,xx} \delta w_{,x} |_{x=l} dt + \int_{t_0}^{t_1} (EJw_{,xxx} - kw) \delta w |_{x=l} dt.$$

Thus, the first variation vanishes for arbitrary variations of w when

$$\mu w_{,tt} + EJw_{,xxxx} = 0$$

inside the interval $(0, l)$ and

$$w = w_{,x} = 0 \quad \text{at } x = 0, \\ w_{,xx} = 0, \quad EJw_{,xxx} - kw = 0 \quad \text{at } x = l.$$

The last boundary condition means that the resultant force acting on the beam is equal to the spring force. This condition can also be written in the form

$$w_{,xxx} - \alpha w = 0 \quad \text{at } x = l, \quad \alpha = \frac{k}{EJ}.$$

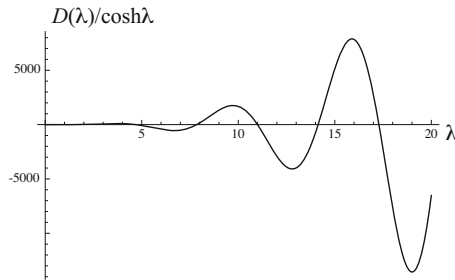

Fig. 3.20 Function $D(\lambda)/\cosh \lambda$

The standard separation of variables leads to the following equation for the shape function

$$q'''' - \kappa^4 q = 0,$$

with $\kappa^4 = \omega^2 \mu / EJ$. The solution of this equation reads

$$q(x) = C_1 \sin \kappa x + C_2 \cos \kappa x + C_3 \sinh \kappa x + C_4 \cosh \kappa x.$$

Substituting this solution into the boundary condition we get four linear equations to determine four coefficients C_1, C_2, C_3, C_4 . The determinant of this system, $D(\lambda)$, reads

$$\begin{vmatrix} 0 & 1 & 0 & 1 \\ 1 & 0 & 1 & 0 \\ -\sin \lambda & -\cos \lambda & \sinh \lambda & \cosh \lambda \\ -\lambda^3 \cos \lambda - \beta \sin \lambda & \lambda^3 \sin \lambda - \beta \cos \lambda & \lambda^3 \cosh \lambda - \beta \sinh \lambda & \lambda^3 \sinh \lambda - \beta \cosh \lambda \end{vmatrix}$$

where $\lambda = \kappa l$ and $\beta = l^3 k/EJ$. Fig. 3.20 shows the plot of function $D(\lambda)/\cosh \lambda$ against λ at $\beta = 1$. The roots of this function correspond to the dimensionless frequencies.

EXERCISE 3.8. An elastic beam is subjected to a harmonic end load as shown in Fig. 3.21. Determine its forced vibration.



Fig. 3.21 Beam under harmonic end load

Solution. The vibration of the beam must be the extremal of the following action functional

$$I[w(x,t)] = \int_{t_0}^{t_1} \int_0^l \left[\frac{1}{2} \mu w_{,t}^2 - \frac{1}{2} EJ w_{,xx}^2 \right] dx dt + \int_{t_0}^{t_1} f(t) w(l,t) dt,$$

where the last term describes the virtual work done by the concentrated load. Varying this action functional we have

$$\begin{aligned} \delta I &= \int_{t_0}^{t_1} \int_0^l (\mu w_{,t} \delta w_{,t} - EJ w_{,xx} \delta w_{,xx}) dx dt + \int_{t_0}^{t_1} f(t) \delta w(l,t) dt \\ &= \int_{t_0}^{t_1} \int_0^l (-\mu w_{,tt} - EJ w_{,xxxx}) \delta w dx dt \\ &\quad - \int_{t_0}^{t_1} EJ w_{,xx} \delta w_{,x} |_{x=l} dt + \int_{t_0}^{t_1} (EJ w_{,xxx} + f(t)) \delta w |_{x=l} dt = 0. \end{aligned}$$

This implies the equation of motion

$$\mu w_{,tt} + EJ w_{,xxxx} = 0,$$

and the boundary conditions at $x = l$

$$w_{,xx} = 0, \quad EJ w_{,xxx} + f(t) = 0.$$

Together with the kinematic boundary conditions at $x = 0$

$$w(0,t) = 0, \quad w_{,x}(0,t) = 0,$$

these constitute the boundary-value problem to determine the forced vibration. For the harmonic end load $f(t) = -\hat{f} \cos \omega t$ we look for the particular solution (describing the forced vibration) in the form

$$w(x, t) = q(x) \cos \omega t.$$

Substituting into the equation of motion and the boundary conditions, we obtain

$$q'''' - \kappa^4 q = 0,$$

with $\kappa^4 = \omega^2 \mu / EJ$, and

$$q(0) = 0, \quad q'(0) = 0,$$

as well as

$$q''(l) = 0, \quad q'''(l) = \frac{\hat{f}}{EJ}.$$

Thus, the solution reads

$$q(x) = C_1 \sin \kappa x + C_2 \cos \kappa x + C_3 \sinh \kappa x + C_4 \cosh \kappa x.$$

Substituting this solution into the above boundary conditions, we get four linear equations to determine four coefficients C_1, C_2, C_3, C_4

$$\begin{pmatrix} 0 & 1 & 0 & 1 \\ 1 & 0 & 1 & 0 \\ -\sin \lambda & -\cos \lambda & \sinh \lambda & \cosh \lambda \\ -\cos \lambda & \sin \lambda & \cosh \lambda & \sinh \lambda \end{pmatrix} \begin{pmatrix} C_1 \\ C_2 \\ C_3 \\ C_4 \end{pmatrix} = \begin{pmatrix} 0 \\ 0 \\ 0 \\ \frac{\hat{f}}{EJ\kappa^3} \end{pmatrix},$$

where $\lambda = \kappa l$.

EXERCISE 3.9. A square membrane is subjected to a harmonic load acting at its center. Determine the forced vibration.

Solution. Consider first the case of an arbitrarily distributed load $f(x, t)$. The equation of motion of the membrane can be obtained from Hamilton's variational principle and from the following action functional

$$I[w(\mathbf{x}, t)] = \int_{t_0}^{t_1} \int_A \left(\frac{1}{2} \mu w_{,t}^2 - \frac{1}{2} S w_{,\alpha} w_{,\alpha} \right) dx dt + \int_{t_0}^{t_1} \int_A f(\mathbf{x}, t) w dx dt.$$

The last term in this action functional represents the work done by the external load. Varying this functional we easily derive the following equation

$$\mu w_{,tt} - S \Delta w = f(\mathbf{x}, t).$$

Dividing this equation by μ , we reduce it to the form

$$w_{,tt} - c^2 \Delta w = p(\mathbf{x}, t),$$

where $p = f/\mu$. For the harmonic load $p = \hat{p}(\mathbf{x}) \cos \omega t$ we look for the particular solution (describing the forced vibration) in the form

$$w(\mathbf{x}, t) = q(\mathbf{x}) \cos \omega t.$$

Substituting this Ansatz into the equation of motion, we obtain the Helmholtz equation

$$-\omega^2 q - c^2 \Delta q = \hat{p}(\mathbf{x})$$

Since the eigenfunctions

$$q_j(\mathbf{x}) = \frac{2}{a} \sin \frac{j_1 \pi x_1}{a} \sin \frac{j_2 \pi x_2}{a}, \quad j = (j_1, j_2), \quad j_1, j_2 = 1, 2, \dots,$$

form a complete orthogonal basis in the space of continuously differentiable functions, we expand both $\hat{p}(\mathbf{x})$ and $q(\mathbf{x})$ in the double Fourier series

$$\hat{p}(\mathbf{x}) = \sum_j P_j q_j(\mathbf{x}), \quad q(\mathbf{x}) = \sum_j Q_j q_j(\mathbf{x}).$$

Substituting these series into the equation for q , making use of the properties of eigenfunctions

$$\Delta q_j + \lambda_j q_j = 0, \quad \lambda_j = \frac{\omega_j^2}{c^2} = \pi^2 \left(\frac{j_1^2}{a^2} + \frac{j_2^2}{b^2} \right),$$

and comparing the terms on the right- and left-hand sides with the same q_j , we obtain for the coefficients Q_j the formulas

$$(\omega_j^2 - \omega^2) Q_j = P_j \quad \Rightarrow \quad Q_j = \frac{P_j}{\omega_j^2 - \omega^2}.$$

For the concentrated load acting in the middle of the membrane $\hat{p}(\mathbf{x}) = \hat{p}_0 \delta(\mathbf{x} - \mathbf{x}_0)$, with $\mathbf{x}_0 = (a/2, a/2)$, the coefficients P_j are given by

$$P_j = \int_A \hat{p}_0 \delta(\mathbf{x} - \mathbf{x}_0) q_j(\mathbf{x}) dx = \hat{p}_0 q_j(\mathbf{x}_0) = \hat{p}_0 \frac{2}{a} \sin \frac{j_1 \pi}{2} \sin \frac{j_2 \pi}{2}.$$

Thus, if $j_1 = 2k_1 - 1$ and $j_2 = 2k_2 - 1$, then $P_j = \frac{2\hat{p}_0}{a} (-1)^{k_1+k_2}$, otherwise $P_j = 0$. Consequently, the solution reads

$$w(\mathbf{x}, t) = \sum_{k_1, k_2=1}^{\infty} \frac{4\hat{p}_0}{a^2} \frac{1}{\omega_j^2 - \omega^2} (-1)^{k_1+k_2} \sin \frac{(2k_1-1)\pi x_1}{a} \sin \frac{(2k_2-1)\pi x_2}{a} \cos \omega t,$$

where $j = (2k_1 - 1, 2k_2 - 1)$.

EXERCISE 3.10. Determine the eigenfrequencies of a circular plate with a simply supported boundary.

Solution. The equation of motion of the plate as well as the boundary conditions are derived from Hamilton's variational principle with the following action functional

$$I[w(\mathbf{x}, t)] = \int_{t_0}^{t_1} \int_A \left[\frac{1}{2} \rho h w_{,t}^2 - \frac{\mu h^3}{12} (\sigma w_{,\alpha\alpha}^2 + w_{,\alpha\beta} w_{,\alpha\beta}) \right] dx dt.$$

Computing the first variation of this action functional in exactly the same manner as in Section 3.5, we derive the equation

$$\rho h w_{,tt} + D \Delta \Delta w = 0.$$

Taking into account that $w = 0$ at ∂A but $v_\gamma \delta w_{,\gamma}$ may be chosen arbitrarily, we derive from Hamilton's variational principle the following boundary conditions

$$w = 0, \quad m_{\alpha\beta} v_\alpha v_\beta = 0 \quad \text{at } \partial A.$$

For the circular plate the standard separation of time and of the polar coordinates r and ϑ leads to

$$w(r, \vartheta, t) = q(r, \vartheta) e^{i\omega t},$$

where

$$q = [aJ_j(\beta r) + bI_j(\beta r)] \begin{cases} \cos j\vartheta \\ \sin j\vartheta \end{cases},$$

and $\beta^4 = \omega^2 \rho h r_m^4 / D = \frac{6\rho\omega^2 r_m^4}{\mu(\sigma+1)h^2}$. In the polar coordinates r, ϑ we have

$$m_{\alpha\beta} v_\alpha v_\beta = \mu \frac{h^3}{6} (\sigma \Delta q + \frac{\partial^2 q}{\partial r^2}) = 0$$

at $r = 1$. Substituting the solution into these boundary conditions, we obtain

$$\begin{aligned} aJ_j(\beta) + bI_j(\beta) &= 0, \\ a\{-\beta^2 J_j(\beta) + (1-\nu)[j^2 J_j(\beta) - \beta J'_j(\beta)]\} \\ + b\{\beta^2 I_j(\beta) + (1-\nu)[j^2 I_j(\beta) - \beta I'_j(\beta)]\} &= 0. \end{aligned}$$

The frequency equation is obtained by the condition of vanishing determinant. When $j = 0$, the frequency equation can be presented in a simple form

$$J_0(\beta)[\beta I_0(\beta) - (1-\nu)I'_0(\beta)] + I_0(\beta)[\beta J_0(\beta) + (1-\nu)J'_0(\beta)] = 0.$$

The three lowest roots β_k of this frequency equation for $\nu = 0.31$ are

$$\beta_1 = 2.5504, \quad \beta_2 = 5.585, \quad \beta_3 = 8.6948.$$

EXERCISE 3.11. Prove the extremal properties of eigenfrequencies of a continuous oscillator based on the minimization of Rayleigh's quotient.

Solution. Consider the variational problem of minimization of Rayleigh's quotient

$$\min_{\mathbf{q} \neq 0} \frac{\langle \mathbf{q}, \mathbf{Kq} \rangle}{\langle \mathbf{q}, \mathbf{Mq} \rangle},$$

where

$$\langle \mathbf{q}, \mathbf{Mq} \rangle = \int_V q_i(\mathbf{x}) \rho_{ij}(\mathbf{x}) q_j(\mathbf{x}) dx,$$

and

$$\langle \mathbf{q}, \mathbf{Kq} \rangle = \int_V [E_{i\alpha j\beta} q_{i,\alpha} q_{j,\beta} + A_{ij}(q_i - B_{\alpha} q_{i,\alpha})(q_j - B_{\beta} q_{j,\beta})] dx.$$

Obviously, this minimization problem is equivalent to the following problem: find the minimum of the functional

$$\langle \mathbf{q}, \mathbf{Kq} \rangle$$

among \mathbf{q} satisfying the constraint

$$\langle \mathbf{q}, \mathbf{Mq} \rangle = 1.$$

To get rid of this constraint we introduce the Lagrange multiplier, λ , and consider the following functional

$$\langle \mathbf{q}, \mathbf{Kq} \rangle - \lambda (\langle \mathbf{q}, \mathbf{Mq} \rangle - 1).$$

Varying this functional with respect to λ and \mathbf{q} we obtain the above constraint together with the following equation

$$(\mathbf{K} - \lambda \mathbf{M})\mathbf{q} = \mathbf{0}.$$

Thus, λ is the eigenvalue. By writing Rayleigh's quotient in terms of the normal coordinates we can show that its minimum corresponds to the smallest eigenvalue.

EXERCISE 3.12. Find the spectrum of radial vibrations for an elastic isotropic sphere of radius a .

Solution. We derive the equation of motion in the spherical coordinates. For the radial vibrations the non-zero component of displacement, u_r , depends only on r . In this situation the non-zero components of the strain tensor are

$$\varepsilon_{rr} = u_{r,r}, \quad \varepsilon_{\theta\theta} = \varepsilon_{\varphi\varphi} = \frac{u_r}{r}.$$

Then the action functional reduces to

$$I[u_r(r)] = \int_{t_0}^{t_1} \int_0^a L(r, u_r, u_{r,r}, u_{r,t}) dr dt,$$

where

$$L(r, u_r, u_{r,r}, u_{r,t}) = 4\pi \left[\frac{1}{2}\rho(u_{r,t})^2 - \frac{1}{2}\lambda(u_{r,r} + \frac{2u_r}{r})^2 - \mu(u_{r,r})^2 - 2\mu(\frac{u_r}{r})^2 \right] r^2.$$

It is easy to show that the Euler-Lagrange equation

$$\frac{\partial}{\partial t} \frac{\partial L}{\partial u_{r,t}} + \frac{\partial}{\partial r} \frac{\partial L}{\partial u_{r,r}} - \frac{\partial L}{\partial u_r} = 0$$

implies

$$\rho u_{r,tt} - (\lambda + 2\mu) \left(u_{r,r} + \frac{2u_r}{r} \right)_{,r} = 0.$$

The standard Ansatz with $u_r(r,t) = q(r)e^{i\omega t}$ reduces this equation to

$$\left(q_{,r} + \frac{2q}{r} \right)_{,r} + k^2 q = 0,$$

where $k^2 = \omega^2/c_d^2$, with $c_d = \sqrt{(\lambda + 2\mu)/\rho}$ being the velocity of dilatational waves. Let $q = \phi_{,r}$. Then in terms of ϕ we have the equation

$$\phi_{,rr} + \frac{2\phi_{,r}}{r} + k^2 \phi = 0.$$

The solution which is regular at $r = 0$ reads

$$\phi = \frac{A}{r} \sin kr.$$

The boundary condition obtained from the above action functional at $r = a$ is

$$\lambda(u_{r,r} + 2\frac{u_r}{r}) + 2\mu u_{r,r} = 0.$$

Taking into account the equation for ϕ , this boundary condition can be written in the form

$$c_d^2 k^2 \phi + 4c_s^2 \frac{\phi_{,r}}{a} = 0,$$

where $c_s = \sqrt{\mu/\rho}$ denotes the velocity of shear waves. Substituting the solution into this boundary condition we obtain the transcendental equation

$$\frac{\tan ka}{ka} = \frac{1}{1 - (kac_d/2c_s)^2}.$$

whose roots determine the spectrum of the radial vibrations.

Chapter 4

Linear Waves

This chapter studies linear waves propagating in continuous media. For homogeneous media the method of solution is Fourier's transform which is based entirely on the linear superposition principle. For weakly inhomogeneous media the variational-asymptotic method has to be used instead.

4.1 Hyperbolic Waves

Differential Equation of Wave Propagation. In contrast to vibrations of continuous systems, waves transport disturbances and energy from one part of the medium to another with a recognizable velocity of propagation. Thus, we are dealing locally with transient processes. The equations governing wave propagation remain exactly the same as the equations of motion for continuous oscillators. In addition, the initial and boundary conditions have to be specified. If the influence of the boundary can be neglected, then it is convenient to consider waves propagating in infinite media. In this case the radiation conditions are required to select the physically meaningful solution.

1-D Problem. We begin first with the most simple situation, namely, with the propagation of hyperbolic waves in one dimension governed by the equation

$$u_{,tt} = c^2 u_{,xx}.$$

As one remembers from Section 3.2, this equation describes flexural vibrations of a pre-stretched string, or longitudinal vibrations of an elastic bar. Now instead of vibrations (or standing waves) we want to analyze wave propagation. If the boundaries of the medium are far away from the point of interest so that waves do not still interact with them, we may consider the idealized situation of waves propagating in an equivalent infinite medium. Introducing the characteristic coordinates $\alpha = x - ct$, $\beta = x + ct$, we transform the above equation to

$$\frac{\partial^2 u}{\partial \alpha \partial \beta} = 0,$$

which yields the general solution obtained first by d'Alembert

$$u(x, t) = f(\alpha) + g(\beta) = f(x - ct) + g(x + ct).$$

This formula represents two waves traveling through the medium with the constant velocity c ; f to the right, and g to the left. Note that the observer moving to the right (or left) with the velocity c does not see any change of wave shape associated with f (or g). Such waves are called dispersionless.

For the initial value problem

$$u(x, 0) = u_0(x), \quad u_t(x, 0) = v_0(x),$$

we determine f and g from the initial conditions

$$u(x, 0) = f(x) + g(x) = u_0(x), \quad u_t(x, 0) = -cf'(x) + cg'(x) = v_0(x),$$

giving

$$u(x, t) = \frac{1}{2}[u_0(x - ct) + u_0(x + ct)] + \frac{1}{2c} \int_{x-ct}^{x+ct} v_0(\xi) d\xi.$$

We can also solve the signaling problem for the half-axis $x \geq 0$ of outgoing waves with

$$u_{,x}(0, t) = p(t).$$

In this case the solution reads

$$u(x, t) = -cq(t - x/c),$$

where $q(t)$ is the integral of $p(t)$.

3-D Problem. According to Hadamard's idea, waves propagating in three dimensions will be easier to study than those in two dimensions, so we start with the 3-D case. We first look for particular solutions of the wave equation

$$u_{,tt} = c^2 \Delta u \tag{4.1}$$

in the 3-D space. This equation describes sound waves in fluids and gases, as well as dilatational or shear waves propagating in infinite elastic solids (see Section 3.6 and exercise 4.2). Since equation (4.1) is linear, its particular solutions always exist in form of harmonic (also called monochromatic) waves¹

$$u(\mathbf{x}, t) = e^{i(\mathbf{k} \cdot \mathbf{x} - \omega t)},$$

¹ We work directly with the complex form of the solution keeping in mind that the real or imaginary part should be taken when necessary.

where \mathbf{k} is the wave vector and ω the frequency. Indeed, substituting this Ansatz into (4.1), we obtain the equation

$$(-\omega^2 + c^2|\mathbf{k}|^2)e^{i(\mathbf{k}\cdot\mathbf{x}-\omega t)} = 0,$$

with $|\mathbf{k}| = \sqrt{k_x^2 + k_y^2 + k_z^2}$ being the magnitude of \mathbf{k} . As the exponential function is not identically zero, ω must be related to \mathbf{k} by

$$\omega = \pm c|\mathbf{k}|.$$

Thus, for each non-zero wave vector \mathbf{k} there are two harmonic waves corresponding to $\omega = c|\mathbf{k}|$ or $\omega = -c|\mathbf{k}|$. We refer to them as *branches*.

For the moment let us concentrate just on one branch since the general solution is simply the linear superposition of them. Taking the real part, we present the monochromatic wave as

$$u(\mathbf{x}, t) = \cos(\mathbf{k} \cdot \mathbf{x} - c|\mathbf{k}|t).$$

We call $\theta(\mathbf{x}, t) = \mathbf{k} \cdot \mathbf{x} - c|\mathbf{k}|t$ phase; it determines the position on the cycle between a crest, where u has a maximum, and a trough, where u achieves a minimum. This particular solution is called a plane wave because the phase surfaces $\theta = \text{const}$ are parallel planes as shown in Fig. 4.1 in 2-D case. The gradient of θ in the space is the wave vector \mathbf{k} , whose direction is normal to the phase planes and whose magnitude $\kappa = |\mathbf{k}|$ is the average number of crests per 2π units of distance in that direction. In Fig. 4.1 the wave vector is $\mathbf{k} = (1, 1)$ in the (x, y) -plane. Similarly, $-\theta_t$ is the frequency $\omega = c\kappa$, the average number of crests per 2π units of time. The wavelength is $\lambda = 2\pi/\kappa$ and the period is $T = 2\pi/\omega$. The wave motion is recognized from the phase. Any particular phase surface moves in the space with the normal velocity $\omega/\kappa = c$ in the direction of \mathbf{k} . Thus, for the wave equation $u_{,tt} = c^2\Delta u$ the phase velocity agrees with the usual propagation speed.

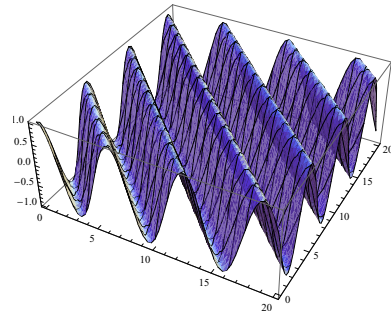

Fig. 4.1 Plot of $\cos(x+y)$

The monochromatic plane waves play a key role in the theory of linear waves propagating in homogeneous media because the general solution can be obtained by the linear superposition of these waves with various wave vectors. This leads to Fourier's integrals, where the contribution of each monochromatic plane wave is Fourier's component of the wave packet. We postpone the derivation of general solution based on this Fourier's analysis to the next Section 4.2. However, in what follows we want to use the monochromatic plane waves to study reflection and refraction of waves.

Reflection and refraction of waves. When a monochromatic plane wave is incident on the boundary between two different media, it undergoes reflection and refraction. The motion in the first medium is a combination of the incident and reflected waves, whereas in the second medium there is only one, the refracted wave. All three waves have the same frequency ω ; the relations between their amplitudes and wave vectors are determined by the boundary conditions. Consider for definiteness the reflection and refraction of sound wave at a plane surface separating two media, say air and water, which we take as the (x, y) -plane. Because of the translational invariance in the x - and y -directions, all three waves have the same components k_x, k_y of the wave vector, but not the same component k_z .

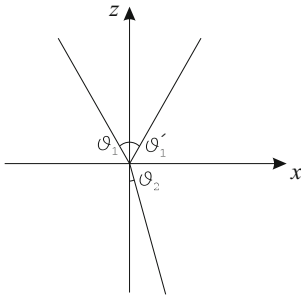

Fig. 4.2 Reflection and refraction of waves

For simplicity let us consider wave propagating in the (x, z) -plane. Then $k_y = 0$ in all three waves, so they are coplanar. Let ϑ be the angle between the direction of wave propagation and the z -axis (see Fig. 4.2). From the equality of $k_x = (\omega/c) \sin \vartheta$ for the incident and reflected waves, it follows that $\vartheta_1 = \vartheta'_1$, i.e. the angle of incidence ϑ_1 is equal to that of reflection ϑ'_1 . The similar equality of k_x for the incident and refracted waves implies Snell's law

$$\frac{\sin \vartheta_1}{\sin \vartheta_2} = \frac{c_1}{c_2},$$

where c_1 and c_2 are the velocities of sound in these two media.

In order to obtain the relation between the intensities of these three waves, we write the velocity potentials as

$$\begin{aligned}\varphi_1 &= A_1 e^{i\omega[(z/c_1) \cos \vartheta_1 + (x/c_1) \sin \vartheta_1 - t]}, \\ \varphi'_1 &= A'_1 e^{i\omega[(-z/c_1) \cos \vartheta_1 + (x/c_1) \sin \vartheta_1 - t]}, \\ \varphi_2 &= A_2 e^{i\omega[(z/c_2) \cos \vartheta_2 + (x/c_2) \sin \vartheta_2 - t]},\end{aligned}$$

where A_1, A'_1 , and A_2 are the complex amplitudes of waves. At the boundary $z = 0$ the pressure $p = -\rho \varphi_{,t}$ and the normal velocities $v_z = \varphi_{,z}$ in the two media must be equal; these conditions lead to the relations

$$\rho_1(A_1 + A'_1) = \rho_2 A_2, \quad \frac{\cos \vartheta_1}{c_1}(A_1 - A'_1) = \frac{\cos \vartheta_2}{c_2} A_2.$$

The reflection coefficient R is defined as the ratio of the average energy flux in the reflected and incident waves. Since the energy flux of sound wave is $c\rho v^2$ (see the general derivation in Section 4.4), we have $R = \overline{v_1'^2}/\overline{v_1^2} = |A'_1|^2/|A_1|^2$, where bar denotes the time average. A simple calculation gives

$$R = \left(\frac{\rho_2 \tan \vartheta_2 - \rho_1 \tan \vartheta_1}{\rho_2 \tan \vartheta_2 + \rho_1 \tan \vartheta_1} \right)^2.$$

The angles ϑ_1 and ϑ_2 are related by Snell's law; expressing ϑ_2 in terms of ϑ_1 , we can put this formula in the form

$$R = \left(\frac{\rho_2 c_2 \cos \vartheta_1 - \rho_1 \sqrt{c_1^2 - c_2^2 \sin^2 \vartheta_1}}{\rho_2 c_2 \cos \vartheta_1 + \rho_1 \sqrt{c_1^2 - c_2^2 \sin^2 \vartheta_1}} \right)^2.$$

For normal incident ($\vartheta_1 = 0$), this formula gives simply

$$R = \left(\frac{\rho_2 c_2 - \rho_1 c_1}{\rho_2 c_2 + \rho_1 c_1} \right)^2.$$

Solution as a Superposition of Spherical Waves. There is a simple way to obtain the solution of the wave equation in 3-D case as a superposition of spherical waves. We start by assuming first the spherical symmetry of a particular solution about the origin: $u = u(r, t)$, where r is the distance from the origin. The wave equation reduces to

$$\frac{1}{c^2} u_{,tt} = u_{,rr} + \frac{2}{r} u_{,r}.$$

This equation can be rewritten as

$$\frac{1}{c^2} (ru)_{,tt} = (ru)_{,rr}$$

which is exactly the 1-D wave equation for ru . Thus, the particular solution reads

$$u(r, t) = \frac{f(r - ct)}{r}.$$

Here we select only the outgoing wave. This selection is equivalent to posing the radiation condition which requires that waves can only propagate from sources to infinity. If the source generating waves is found at point $\boldsymbol{\xi}$, then the particular solution takes the form

$$u(\mathbf{x}, t) = \frac{f(|\mathbf{x} - \boldsymbol{\xi}| - ct)}{|\mathbf{x} - \boldsymbol{\xi}|}.$$

Now the particular solution of (4.1) can be constructed as a linear superposition of spherical waves

$$\phi(\mathbf{x}, t) = \int \psi(\boldsymbol{\xi}) \frac{\delta(|\mathbf{x} - \boldsymbol{\xi}| - ct)}{|\mathbf{x} - \boldsymbol{\xi}|} d\xi, \quad (4.2)$$

where $d\xi = d\xi_1 d\xi_2 d\xi_3$. In the integrand we take Dirac's delta function representing the unit source, while function $\psi(\boldsymbol{\xi})$ accounts for the fact that waves coming from different points will have in general different intensities. The form (4.2) suggests the introduction of spherical coordinates $(\rho, \vartheta, \varphi)$ with the origin at \mathbf{x} yielding

$$\begin{aligned}
\phi(\mathbf{x}, t) &= \int_0^\infty \int_0^\pi \int_0^{2\pi} \psi(\mathbf{x} + \rho \mathbf{l}) \delta(\rho - ct) \rho \sin \vartheta d\varphi d\vartheta d\rho \\
&= ct \int_0^\pi \int_0^{2\pi} \psi(\mathbf{x} + ct \mathbf{l}) \sin \vartheta d\varphi d\vartheta,
\end{aligned} \tag{4.3}$$

where \mathbf{l} is the unit vector from \mathbf{x} to $\boldsymbol{\xi}$ having the cartesian components

$$\mathbf{l} = (\sin \vartheta \cos \varphi, \sin \vartheta \sin \varphi, \cos \vartheta).$$

As $t \rightarrow 0$ the right-hand side of (4.3) tends to zero. For a continuously differentiable function $\psi(\mathbf{x})$ we may differentiate this expression with respect to t and find the limit as $t \rightarrow 0$

$$\phi_{,t}(\mathbf{x}, 0) = 4\pi c \psi(\mathbf{x}).$$

Thus, the integral

$$\phi(\mathbf{x}, t) = \frac{t}{4\pi} \int_0^\pi \int_0^{2\pi} v_0(\mathbf{x} + ct \mathbf{l}) \sin \vartheta d\varphi d\vartheta$$

solves equation (4.1) with the initial conditions

$$u(\mathbf{x}, 0) = 0, \quad u_{,t}(\mathbf{x}, 0) = v_0(\mathbf{x}).$$

Note that this solution can also be represented as a surface integral

$$\phi(\mathbf{x}, t) = \frac{1}{4\pi c^2 t} \int_{S(t)} v_0(\mathbf{x} + ct \mathbf{l}) da,$$

where $S(t)$ is the spherical surface with center at \mathbf{x} and radius ct .

To satisfy the remaining initial condition $u(\mathbf{x}, 0) = u_0(\mathbf{x})$ we use the following property: if ϕ is a solution of (4.1), then its time derivative $\phi_{,t}$ is also the solution. Consider the solution of the form

$$\chi(\mathbf{x}, t) = \phi_{,t},$$

where ϕ is given by (4.3). In this case it is easy to check that, as $t \rightarrow 0$,

$$\chi(\mathbf{x}, 0) = 4\pi c \psi(\mathbf{x}), \quad \chi_{,tt}(\mathbf{x}, 0) = \phi_{,tt} = c^2 \Delta \phi = 0.$$

Therefore we choose now $\psi(\mathbf{x}) = u_0(\mathbf{x})/4\pi c$ and get for χ

$$\chi(\mathbf{x}, t) = \frac{\partial}{\partial t} \left[\frac{1}{4\pi c^2 t} \int_{S(t)} u_0(\mathbf{x} + ct \mathbf{l}) da \right].$$

The complete solution reads

$$u(\mathbf{x}, t) = \frac{\partial}{\partial t} \left[\frac{1}{4\pi c^2 t} \int_{S(t)} u_0(\mathbf{x} + ct \mathbf{l}) da \right] + \frac{1}{4\pi c^2 t} \int_{S(t)} v_0(\mathbf{x} + ct \mathbf{l}) da. \tag{4.4}$$

Equation (4.4), called Poisson’s formula, represents the total contribution of the instantaneous sources which send spherical waves to point \mathbf{x} at time t ; they are all exactly a distance ct away and their contributions traveling with speed c arrive at \mathbf{x} just at time t . Notice that sources inside $S(t)$ do not contribute to the solution at \mathbf{x} . Thus, there is no “tail” for spherical waves. This is no longer so in 2-D case as will be seen in the next paragraph.

2-D Problem. The solution to the 2-D problem can be obtained from the 3-D solution by assuming $u_0(\mathbf{x})$ and $v_0(\mathbf{x})$ to be independent of x_3 . Suppose now that nonzero values of $u_0(x_1, x_2)$, $v_0(x_1, x_2)$ are specified in a finite domain C_0 of the (x_1, x_2) -plane. From the 3-D point of view, the non-zero initial data occupy the cylinder C with generators parallel to the x_3 -axis based on the cross section C_0 . Thus, the domain of initial disturbances is no longer compact in the space. For a point outside the cylinder C , the construction of wavefront is as before, but the spheres with the center at \mathbf{x} will intersect C at all time after the first time of intersection (see Fig. 4.3). This accounts for the “tail” in the 2-D case and shows clearly the difference between 2-D and 3-D cases.

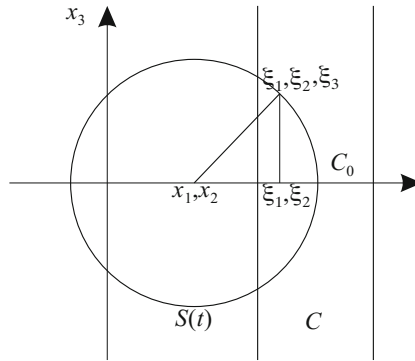

Fig. 4.3 Reduction of wavefront from three to two dimensions

Let us consider now the integrals in (4.4) at some fixed point $(x_1, x_2, 0)$. At point (ξ_1, ξ_2, ξ_3) on $S(t)$ (see Fig. 4.3) the value of u_0 is $u_0(\xi_1, \xi_2)$. The outward normal to the sphere has a component n_3 given by

$$n_3 = \frac{\xi_3}{ct} = \pm \frac{\sqrt{c^2t^2 - (x_1 - \xi_1)^2 - (x_2 - \xi_2)^2}}{ct}.$$

The surface element da is equal to $d\xi_1 d\xi_2 / |n_3|$, where $d\xi_1 d\xi_2$ is its projection in the (x_1, x_2) -plane. Therefore, taking into account the two equal contributions from above and below the (x_1, x_2) -plane, we have

$$\frac{1}{4\pi c^2 t} \int_{S(t)} u_0(\mathbf{x} + ct\mathbf{l}) da = \frac{1}{2\pi c} \int_{\sigma(t)} \frac{u_0(\xi_1, \xi_2) d\xi_1 d\xi_2}{\sqrt{c^2t^2 - (x_1 - \xi_1)^2 - (x_2 - \xi_2)^2}},$$

where $\sigma(t)$ is the interior of the projection of $S(t)$ onto the (x_1, x_2) -plane:

$$\sigma(t) = \{(\xi_1, \xi_2) \mid (x_1 - \xi_1)^2 + (x_2 - \xi_2)^2 \leq c^2 t^2\}.$$

Thus, the solution of 2-D problem reads

$$u(x_1, x_2, t) = \frac{\partial}{\partial t} \left[\frac{1}{2\pi c} \int_{\sigma(t)} \frac{u_0(\xi_1, \xi_2) d\xi_1 d\xi_2}{\sqrt{c^2 t^2 - (x_1 - \xi_1)^2 - (x_2 - \xi_2)^2}} \right] + \frac{1}{2\pi c} \int_{\sigma(t)} \frac{v_0(\xi_1, \xi_2) d\xi_1 d\xi_2}{\sqrt{c^2 t^2 - (x_1 - \xi_1)^2 - (x_2 - \xi_2)^2}}.$$

Since the integrals are taken over the whole domain inside the circle $(x_1 - \xi_1)^2 + (x_2 - \xi_2)^2 = c^2 t^2$, not just its boundary, the disturbance continues even after this circle completely surrounds the initial domain C_0 .

Geometrical Optics. Although the exact solution to the wave equation has been found, the computation of Poisson's integrals is not always easy, even if we do it numerically. A simplification is possible if the wave packet may be regarded as plane in any small region of the medium. For this to be so it is necessary that the amplitude and the direction of propagation vary only slightly in one wavelength. If this condition holds, we can introduce the idea of *rays* as lines whose tangent at any point coincides with the direction of wave propagation. Then, to find the wavefront we need just to find the rays while ignoring the nature of wave propagation. This task will be done within the so-called geometrical optics which turns out to be valid in the high frequency (short wave) approximation.

We derive the equations of geometrical optics by assuming the periodic solution with a given frequency ω : $u(\mathbf{x}, t) = w(\mathbf{x})e^{-i\omega t}$. Then the wave equation reduces to Helmholtz's equation

$$\Delta w + \frac{\omega^2}{c^2} w = 0.$$

For large value of ω/c , a standard method of finding the asymptotic solutions² is to take

$$w = e^{i\omega\sigma(\mathbf{x})} [w_0(\mathbf{x}) + \frac{1}{\omega} w_1(\mathbf{x}) + \dots], \quad (4.5)$$

where functions $\sigma(\mathbf{x})$ and $w_j(\mathbf{x})$ are to be determined. Substituting (4.5) into Helmholtz's equation and keeping the asymptotically leading terms only, we obtain

$$e^{i\omega\sigma(\mathbf{x})} [\omega^2 (-\sigma_{,\alpha} \sigma_{,\alpha} + \frac{1}{c^2}) (w_0 + \frac{1}{\omega} w_1) + i\omega (\Delta \sigma w_0 + 2\sigma_{,\alpha} w_{0,\alpha}) + \dots] = 0.$$

The exponential function can be dropped in this equation. Then, equating the asymptotically leading terms at ω^2 and ω to zero, we obtain

² Which is called WKB-method [6].

$$\begin{aligned} \sigma_{,\alpha}\sigma_{,\alpha} &= \frac{1}{c^2}, \\ \Delta\sigma w_0 + 2\sigma_{,\alpha}w_{0,\alpha} &= 0. \end{aligned} \tag{4.6}$$

The first equation is called eikonal equation which determines $\sigma(\mathbf{x})$. The second equation, called transport equation, can be used to find $w_0(\mathbf{x})$.

The eikonal equation (4.6)₁, as a nonlinear partial differential equation of first order, may be solved by the method of characteristic curves [12]. If we introduce $p_\alpha = \sigma_{,\alpha}$ and write this equation as

$$H \equiv \frac{1}{2}cp_\alpha p_\alpha - \frac{1}{2}c^{-1} = 0,$$

the characteristic curves are defined by the equation

$$\frac{dx_\alpha}{ds} = cp_\alpha.$$

Parameter s is the arc-length along the characteristic curve, because $c^2 p_\alpha p_\alpha = 1$. The full set of characteristic equations reads

$$\frac{dx_\alpha}{ds} = cp_\alpha, \quad \frac{dp_\alpha}{ds} = 0, \quad \frac{d\sigma}{ds} = \frac{1}{c}.$$

Looking at the asymptotic solution (4.5), one may recognize that $\theta = \omega(\sigma(\mathbf{x}) - t)$ is the phase of the wave packet. Let us choose the initial phase such that $\theta = 0$ corresponds to the wave front. Thus, the equation of the wave front is $\sigma(\mathbf{x}) = t$. Since the vector $\mathbf{p} = \nabla\sigma$ is normal to the wavefront, the first equation for the characteristics tells us that the rays are also normal to it. The second equation shows that \mathbf{p} is constant on the ray, so the rays must be straight lines. The new wavefront at time $t + t_1$ (with small t_1) can be constructed by drawing the family of straight lines normal to the wavefront at time t , and by the third equation, $\sigma = s/c$, so $t = s/c$, and the new wavefront is a distance ct_1 out along the rays (see Fig. 4.4). This is Huygens' principle which agrees also with Poisson's exact solution (4.4) found previously.

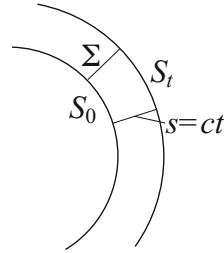

Fig. 4.4 Wavefront and rays

It remains to solve the transport equation which is the linear equation for w_0 . Its characteristics are the same rays, so we can write this equation as

$$\frac{1}{w_0} \frac{dw_0}{ds} = -\frac{1}{2}\Delta\sigma.$$

The integration is straightforward once $\sigma(\mathbf{x})$ has been determined. But due to the implicit form of $\sigma(\mathbf{x})$ we proceed a little differently. First we note that (4.6)₂ takes the divergence form

$$(\sigma_{,\alpha} w_0^2)_{,\alpha} = 0.$$

Let us consider a tube formed by rays going from the initial wavefront S_0 to the current wavefront S_t as shown in Fig. 4.4. We integrate this equation over the volume of the tube. The use of Gauss' theorem gives

$$\int n_\alpha \sigma_{,\alpha} w_0^2 da = 0,$$

where \mathbf{n} is the outward normal and the surface integral must be taken over the sides Σ and ends S_0, S_t of the ray tube. As the rays are orthogonal to the wavefronts $\sigma = t$, $n_\alpha \sigma_{,\alpha} = 0$ on Σ . On S_t the normal \mathbf{n} and $\nabla\sigma$ are in the same direction, so $n_\alpha \sigma_{,\alpha} = |\nabla\sigma| = 1/c$. Similarly, $n_\alpha \sigma_{,\alpha} = -|\nabla\sigma| = -1/c$ on S_0 . Thus,

$$\int_{S_t} w_0^2 da = \int_{S_0} w_0^2 da.$$

This equation expresses the conservation of energy flux along the ray tube.

The geometrical optics can also be developed for anisotropic and inhomogeneous media [53]. However, one should be cautious near the point where $c = 0$ (called the turning point) as well as near the caustics, where this type of approximation needs to be modified.

4.2 Dispersive Waves

Differential Equation and Dispersion Relation. Typically, the differential equation governing the propagation of dispersive waves in a homogeneous medium can be written as

$$P(\partial_t, \partial_\alpha)u = 0. \quad (4.7)$$

Here $P(r, s_\alpha)$ is a polynomial of the variables r and s_α with constant coefficients, ∂_t and ∂_α are the partial derivatives with respect to t and x_α , respectively. Some examples in 1-D case which will be used as illustration are

$$\begin{aligned} u_{,tt} + \omega_0^2 u - c^2 u_{,xx} &= 0, & P(\partial_t, \partial_x) &= \partial_t^2 + \omega_0^2 - c^2 \partial_x^2, \\ u_{,tt} + \gamma^2 u_{,xxxx} &= 0, & P(\partial_t, \partial_x) &= \partial_t^2 + \gamma \partial_x^4, \\ u_{,t} + \alpha u_{,x} + \beta u_{,xxx} &= 0, & P(\partial_t, \partial_x) &= \partial_t + \alpha \partial_x + \beta \partial_x^3. \end{aligned} \quad (4.8)$$

The first equation describes free vibrations of a string with an additional restoring force proportional to u , or thickness vibrations of a rod [31]. It is also the Klein-Gordon equation of quantum mechanics. The second equation of (4.8) corresponds to Bernoulli-Euler's beam theory (3.27) with $\gamma = \sqrt{EI/\mu}$. The last equation is the linearized version of Korteweg-de Vries equation describing small amplitude long water waves and various other dispersive waves.

Since (4.7) is a linear differential equation with constant coefficients, its particular solutions always exist in form of harmonic waves

$$u(\mathbf{x}, t) = e^{i(\mathbf{k} \cdot \mathbf{x} - \omega t)},$$

where \mathbf{k} is the wave vector and ω the frequency. Indeed, substituting this Ansatz into (4.7) and using the property of exponential function, we see that \mathbf{k} and ω have to be related by the equation

$$P(-i\omega, ik_\alpha) = 0.$$

This is the so called dispersion relation which contains all the information about the differential equation. Knowing this dispersion relation we can restore the governing equation by using the correspondence: $\partial_t \leftrightarrow -i\omega$, $\partial_\alpha \leftrightarrow ik_\alpha$. Note that the above derivation can easily be generalized for the situation when \mathbf{u} is a vector. In this case P becomes a matrix, whose elements are polynomials of r and s_α . The harmonic wave form of particular solutions remains, with a small modification that a constant vector \mathbf{a} as a factor has to be included. Nontrivial solutions exist for the vanishing determinant of the matrix, whose elements are polynomials of $-i\omega$ and ik_α , yielding the dispersion relation (see exercise 4.4).

We assume that the dispersion relation may be solved with respect to ω giving real roots

$$\omega = \Omega(\mathbf{k}). \quad (4.9)$$

In general there will be a number of such solutions, with different functions $\Omega(\mathbf{k})$. We refer to them as *branches*. For example, if u satisfies Bernoulli-Euler's beam equation (4.8)₂, then the dispersion relation reads

$$-\omega^2 + \gamma^2 k^4 = 0.$$

Solving this with respect to ω , we obtain two branches

$$\omega = \gamma k^2, \quad \omega = -\gamma k^2.$$

In contrary, the linearized Korteweg-de Vries equation (4.8)₃ yields only one branch given by

$$\omega = \alpha k - \beta k^3.$$

For the present we study just one branch since the general solution is simply the linear superposition of them. The monochromatic plane wave corresponding to this branch is

$$u = \cos(\mathbf{k} \cdot \mathbf{x} - \Omega(\mathbf{k})t).$$

We call as before $\theta = \mathbf{k} \cdot \mathbf{x} - \Omega(\mathbf{k})t$ phase which determines the wave motion. Any particular phase surface moves in the space with the normal velocity $\Omega(\mathbf{k})/\kappa$ in the direction of \mathbf{k} , where $\kappa = |\mathbf{k}|$. We define the phase velocity as

$$\mathbf{c} = \frac{\Omega(\mathbf{k})}{\kappa} \mathbf{n},$$

where \mathbf{n} is the unit vector in the \mathbf{k} -direction. For the hyperbolic waves governed by the equation $u_{,tt} = c^2 \Delta u$ considered in the previous Section the phase velocity is constant and agrees with the propagation speed c . In general \mathbf{c} depends on κ , so different waves propagate with different velocities causing the change of shape. This explains the adjective “dispersive” for such waves. We classify waves as dispersive if $\Omega(\mathbf{k})$ is real and the determinant of the matrix $\frac{\partial^2 \Omega}{\partial k_\alpha \partial k_\beta}$ is not identically zero (see [53]). This definition excludes hyperbolic waves.

Solution. The general solution of (4.7) can be obtained by the linear superposition of particular solutions using Fourier’s integral

$$u(\mathbf{x}, t) = \int \psi(\mathbf{k}) e^{i\mathbf{k}\cdot\mathbf{x} - i\Omega(\mathbf{k})t} d\mathbf{k},$$

where $d\mathbf{k} = dk_1 dk_2 dk_3$. Function $\psi(\mathbf{k})$ accounts for the intensity of waves with different \mathbf{k} and may be chosen to satisfy arbitrary initial data, provided these data are described by regular functions admitting the Fourier transform. For illustration let us consider the first two equations in (4.8). Each of them has two branches $\omega = \pm \Omega(k)$, and since we are in 1-D situation,

$$u(x, t) = \int_{-\infty}^{\infty} \psi_1(k) e^{ikx - i\Omega(k)t} dk + \int_{-\infty}^{\infty} \psi_2(k) e^{ikx + i\Omega(k)t} dk. \quad (4.10)$$

As there are two branches, $u(x, t)$ must satisfy two initial conditions

$$u(x, 0) = u_0(x), \quad u_{,t}(x, 0) = v_0(x).$$

This leads to

$$\begin{aligned} \int_{-\infty}^{\infty} [\psi_1(k) + \psi_2(k)] e^{ikx} dk &= u_0(x), \\ \int_{-\infty}^{\infty} -i\Omega(k) [\psi_1(k) - \psi_2(k)] e^{ikx} dk &= v_0(x). \end{aligned}$$

Applying the Fourier transform to these equations, we obtain

$$\begin{aligned} \psi_1(k) + \psi_2(k) &= \frac{1}{2\pi} \int_{-\infty}^{\infty} u_0(x) e^{-ikx} dx = U_0(k), \\ -i\Omega(k) [\psi_1(k) - \psi_2(k)] &= \frac{1}{2\pi} \int_{-\infty}^{\infty} v_0(x) e^{-ikx} dx = V_0(k). \end{aligned}$$

Solving the above equations with respect to $\psi_1(k)$ and $\psi_2(k)$ gives

$$\psi_1(k) = \frac{1}{2} \left[U_0(k) + \frac{iV_0(k)}{\Omega(k)} \right], \quad \psi_2(k) = \frac{1}{2} \left[U_0(k) - \frac{iV_0(k)}{\Omega(k)} \right].$$

Since $u_0(x)$ and $v_0(x)$ are real, their Fourier images $U_0(k)$ and $V_0(k)$ satisfy the properties

$$U_0(-k) = U_0^*(k), \quad V_0(-k) = V_0^*(k),$$

where asterisks denote complex conjugates. Thus, if $\Omega(k)$ is odd function, then

$$\psi_1(-k) = \psi_1^*(k), \quad \psi_2(-k) = \psi_2^*(k).$$

If $\Omega(k)$ is even function, we have

$$\psi_1(-k) = \psi_2^*(k), \quad \psi_2(-k) = \psi_1^*(k).$$

It is easy to check that the solution is real in both cases as expected.

Large Time Asymptotics. Although Fourier's integrals give the exact solution, its behavior is still difficult to analyze. For wave propagation it is important to know the behavior of solution in the limits $t \rightarrow \infty$ and $x \rightarrow \infty$ while x/t is held fixed. Let us analyze first the typical integral

$$u(x, t) = \int_{-\infty}^{\infty} \psi(k) e^{ikx - i\Omega(k)t} dk$$

in 1-D case. In the limit $t \rightarrow \infty$ at fixed x/t we can write this integral as

$$u(x, t) = \int_{-\infty}^{\infty} \psi(k) e^{-i\chi(k)t} dk, \quad (4.11)$$

where $\chi(k)$ is the following function

$$\chi(k) = \Omega(k) - k \frac{x}{t}.$$

Here x/t is regarded as a fixed parameter. The asymptotic behavior of integral (4.11) as $t \rightarrow \infty$ can be studied by the method of stationary phase [6], according to which the main contribution to the integral comes from the neighborhood of stationary points of $\chi(k)$ such that

$$\chi'(k) = \Omega'(k) - \frac{x}{t} = 0. \quad (4.12)$$

Otherwise, the integrand oscillates rapidly and makes little net contribution to $u(x, t)$.

Assume first that $\chi(k)$ has one stationary point at $k = k_s$. To find the leading contribution we expand $\psi(k)$ and $\chi(k)$ in Taylor's series near $k = k_s$

$$\psi(k) \simeq \psi(k_s), \quad \chi(k) \simeq \chi(k_s) + \frac{1}{2} \chi''(k_s) (k - k_s)^2,$$

provided $\chi''(k_s) \neq 0$. Substitution of these formulas in (4.11) leads to

$$u(x, t) \simeq \psi(k_s) e^{-i\chi(k_s)t} \int_{-\infty}^{\infty} e^{-\frac{i}{2}(k-k_s)^2 \chi''(k_s)t} dk.$$

The remaining integral can be reduced to the standard integral

$$\int_{-\infty}^{\infty} e^{-\alpha z^2} dz = \sqrt{\frac{\pi}{\alpha}}$$

by rotating the path of integration through $\pm\pi/4$; the sign should be chosen to be the same as that of $\chi''(k_s)$. Thus,

$$u(x, t) \simeq \psi(k_s) \sqrt{\frac{2\pi}{t|\chi''(k_s)|}} e^{ik_s x - i\Omega(k_s)t - \frac{i\pi}{4} \text{sign}\chi''(k_s)}.$$

If there are several stationary points, the contributions from their neighborhoods have to be summed up to get the final result.

For the case of two branches with $\omega = \pm\Omega(k)$, the solution is given by (4.10). Assuming further that $\Omega'(k)$ is monotonic and positive for $k > 0$, we analyze the asymptotic behavior of (4.10) for $x > 0$. If $\Omega(k)$ is even, then $\Omega'(k)$ is odd and there is only one positive stationary point for the first branch denoted by $k_s(x, t)$: $\Omega'(k) = x/t$ for $x/t > 0$. The second branch has also one stationary point equal to $-k_s(x, t)$. Combining two contributions of the branches, we get

$$u(x, t) \simeq 2\text{Re} \left[\psi_1(k_s) \sqrt{\frac{2\pi}{t|\chi''(k_s)|}} e^{ik_s x - i\Omega(k_s)t - \frac{i\pi}{4} \text{sign}\chi''(k_s)} \right] \quad \text{for } x/t > 0. \quad (4.13)$$

It is easy to see that the case of odd function $\Omega(k)$ leads to the same result.

Group Velocity. At any point (x, t) formula (4.13) determines a local wave number $k_s(x, t)$ and the corresponding local frequency $\omega_s(x, t) = \Omega(k_s(x, t))$. By introducing a phase

$$\theta(x, t) = k_s(x, t)x - \omega_s(x, t)t,$$

we may present (4.13) in the form

$$u(x, t) \simeq \text{Re}[A(x, t)e^{i\theta(x, t)}], \quad (4.14)$$

where the complex amplitude is

$$A(x, t) = 2\psi_1(k_s) \sqrt{\frac{2\pi}{t|\chi''(k_s)|}} e^{-\frac{i\pi}{4} \text{sign}\chi''(k_s)}.$$

The difference between (4.14) and the monochromatic waves is that A , k , and ω are no longer constants. However, this asymptotic formula still represents a nonuniform wave packet, with a phase θ describing the oscillations between crests and troughs. It is natural to define the local wave number and frequency as $\theta_{,x}$ and $-\theta_{,t}$, respectively. In our nonuniform case we have

$$\begin{aligned} \theta_{,x} &= k_{s,x}x + k_s - \Omega'(k_s)k_{s,x}t = k_s(x, t), \\ \theta_{,t} &= k_{s,t}x - \Omega'(k_s)k_{s,t}t - \Omega(k_s) = -\omega_s(x, t), \end{aligned}$$

so the local wave number and frequency introduced above agree with these definitions. Moreover, the local wave number and frequency satisfy the dispersion relation even in the nonuniform wave packet. Mention that the relative changes of the local wave number k_s in one period and in one wavelength are small. Indeed, from (4.12) we see that the quantities

$$\frac{k_{s,x}}{k_s} = \frac{\Omega'}{k_s \Omega''} \frac{1}{x}, \quad \frac{k_{s,t}}{k_s} = -\frac{1}{k_s \Omega''} \frac{1}{t}$$

are small for large x and t . Thus, $k_s(x, t)$ is a slowly changing function in one period and one wavelength. The same is true of the frequency ω_s and amplitude A .

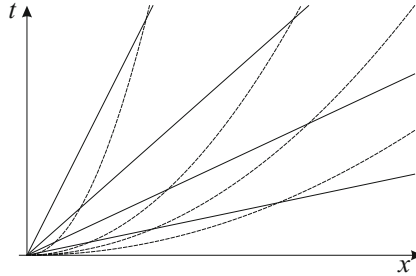

Fig. 4.5 Group (solid) and phase (dashed) lines for waves in beam

Let us have a closer look at the equation (4.12) determining $k_s(x, t)$. According to that equation an observer moving with the velocity $\Omega'(k_s)$ will see the wave number k_s and the frequency ω_s . Therefore we call the velocity

$$\Omega'(k) = \frac{d\omega}{dk}$$

group velocity, or the velocity for a group of waves. To illustrate the distinction between the phase and the group velocities we consider equation (4.8)₂ for Bernoulli-Euler’s beam. The dispersion relation for the branch of waves propagating to the right is

$$\Omega(k) = \gamma k^2.$$

Therefore the equation determining k becomes $x/t = \Omega'(k) = 2\gamma k$. Thus,

$$k = \frac{x}{2\gamma t}, \quad \omega = \frac{x^2}{4\gamma t^2}, \quad \theta = kx - \omega t = \frac{x^2}{4\gamma t}.$$

The group lines of constant k and ω are the straight lines $\frac{x}{2\gamma t} = \text{const}$. The lines of constant phase $\theta = \text{const}$ are the parabola $\frac{x^2}{4\gamma t} = \text{const}$. These two families of lines are shown in Fig. 4.5. We see that the group velocity $\Omega'(k) = 2\gamma k$ is twice the phase velocity $\omega/k = \gamma k$ for waves propagating in Bernoulli-Euler’s beam.

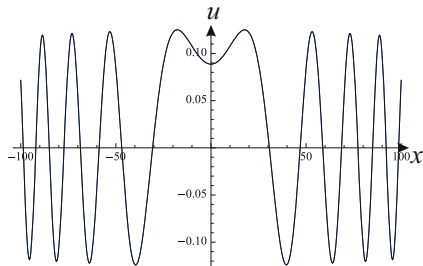

Fig. 4.6 Comparison of exact and approximate solutions

To compare the solution obtained by the numerical integration of Fourier's integrals with the asymptotic solution (4.14) let us set $\gamma = 1$ and assume the initial conditions as follows

$$u(x, 0) = u_0(x) = 2\pi e^{-x^2}, \quad u_t(x, 0) = v_0(x) = 0.$$

Then $\psi_1(k) = e^{-k^2/4}/\sqrt{2}$ and the asymptotic solution takes the form

$$u(x, t) \simeq \psi_1\left(\frac{x}{2t}\right) \sqrt{\frac{\pi}{t}} \cos\left(\frac{x^2}{4t} - \frac{\pi}{4}\right).$$

Fig. 4.6 plots the exact solution in terms of Fourier's integrals computed numerically at time $t = 100$ and the above asymptotic solution at the same time, where the results are nearly identical.

The other important role of the group velocity appears in studying the distribution of amplitude $A(x, t)$. It turns out that $|A|^2$ propagates with the group velocity. To show this let us compute the integral of $|A|^2$ between two points $x_2 > x_1 > 0$. From the above formula for A we have

$$Q(t) = \int_{x_1}^{x_2} AA^* dx = 8\pi \int_{x_1}^{x_2} \frac{\psi_1(k_s) \psi_1^*(k_s)}{t |\Omega''(k_s)|} dx.$$

In this integral k_s is the root of (4.12). Using the transformation $x = \Omega'(k)t$ as a change of variable $x \rightarrow k$, we rewrite $Q(t)$ in the form

$$Q(t) = 8\pi \int_{k_1}^{k_2} \psi_1(k) \psi_1^*(k) dk,$$

provided $\Omega''(k) > 0$, where k_1 and k_2 are defined by

$$x_1 = \Omega'(k_1)t, \quad x_2 = \Omega'(k_2)t.$$

If $\Omega''(k) < 0$, the order of the limits must be reversed. Now, if k_1 and k_2 are held fixed as t varies, $Q(t)$ remains constant. But for the fixed k_1 and k_2 the points x_1

and x_2 are moving with the group velocities. Thus, the total amount of $|A|^2$ between any pairs of group lines remains constant, and in this sense, $|A|^2$ propagates with the group velocity. Moreover, we will show in Section 4.4 that the energy also propagates with the group velocity. This puts the question to the radiation conditions for the dispersive waves.

Kinematic Derivation of Group Velocity. We see from the previous paragraph that the concept of group velocity is quite crucial in understanding the phenomenon of wave propagation. This concept must appear and be equally important for inhomogeneous media as well as for non-linear problems, where Fourier's analysis are not directly applicable. Therefore we try to develop below the direct kinematic approach based on the more intuitive arguments rather than using Fourier's integrals and the method of stationary phase. We assume that a wave packet under consideration possesses a phase function $\theta(x, t)$, and that the wave number and frequency defined by

$$k = \theta_{,x}, \quad \omega = -\theta_{,t}, \quad (4.15)$$

are *slowly* changing functions of x and t . If, further, we know or can derive for them a dispersion relation

$$\omega = \Omega(k), \quad (4.16)$$

then we have an equation for θ and we could proceed to solve it to determine the geometry of the wave pattern. The convenient way is to use the kinematic relation

$$k_{,t} + \omega_{,x} = 0,$$

which follows from (4.15). This equation can be regarded as the conservation of waves, with k being the density of waves and ω the flux of waves. Combining it with (4.16), we get a non-linear partial differential equation to determine $k(x, t)$

$$k_{,t} + C(k)k_{,x} = 0, \quad C(k) = \Omega'(k). \quad (4.17)$$

We see that the group velocity $C(k)$ is the propagation velocity for the wave number k . This equation can be solved by the method of characteristics. For an initial distribution $k = f(x)$ at $t = 0$ the solution is

$$k = f(\xi), \quad x = \xi + v_g(\xi)t,$$

where $v_g(\xi) = C(f(\xi))$. Thus, the observer moving with the group velocity sees always the same local wave number k . It is interesting that the above equation for k is non-linear and hyperbolic, even though the original problem is linear and in general non-hyperbolic as in example (4.8)₂. In this sense one can preserve the association of wave propagation with hyperbolic equations, but there is a considerable non-hyperbolic background.

Extensions to 2- and 3-D Cases. It is not difficult to extend the obtained results to 2- or 3-D problems. Since the exact solution is expressed in terms of multiple Fourier's

integrals, the asymptotically leading terms in the limit $t \rightarrow \infty$ with \mathbf{x}/t being held fixed can be obtained by the method of stationary phase. For d -dimensional space we can show that

$$u(\mathbf{x}, t) = \int \psi(\mathbf{k}) e^{i\mathbf{k} \cdot \mathbf{x} - i\Omega(\mathbf{k})t} d\mathbf{k} \\ \simeq \psi(\mathbf{k}_s) \left(\frac{2\pi}{t} \right)^{d/2} \left(\det \left| \frac{\partial \Omega}{\partial k_\alpha \partial k_\beta} \right| \right)^{-1/2} e^{i\mathbf{k}_s \cdot \mathbf{x} - i\Omega(\mathbf{k}_s)t + i\zeta},$$

where \mathbf{k}_s satisfies the equation

$$\frac{\partial \Omega(\mathbf{k})}{\partial k_\alpha} = \frac{x_\alpha}{t},$$

and ζ depends on the number of factors $i\pi/4$ arising from the path rotation. We could use this asymptotic solution to study the group velocity in 2- or 3-D cases. However, it is simpler to develop the direct kinematic approach which may also be applied to weakly inhomogeneous media.

We consider the slowly varying wave packet in the form

$$u(\mathbf{x}, t) = a \cos \theta,$$

where the amplitude a and the phase θ are functions of \mathbf{x} and t . We define the wave vector \mathbf{k} and frequency ω by

$$k_\alpha = \theta_{,\alpha}, \quad \omega = -\theta_{,t}. \quad (4.18)$$

We assume that a dispersion relation is known and can be written as

$$\omega = \Omega(\mathbf{x}, \mathbf{k}). \quad (4.19)$$

For homogeneous media the dispersion relation does not depend on \mathbf{x} and can be obtained from the monochromatic plane waves. For weakly inhomogeneous media it would appear reasonable to find the dispersion relations first for constant parameters of the media and then reinsert their dependence on \mathbf{x} . This will be justified by the variational-asymptotic method in Section 4.4.

Now, by eliminating θ from (4.18), we have

$$k_{\alpha,t} + \omega_{,\alpha} = 0, \quad k_{\alpha,\beta} - k_{\beta,\alpha} = 0.$$

Then, if $\omega = \Omega(\mathbf{x}, \mathbf{k})$ is inserted into the first of these equations,

$$k_{\alpha,t} + \frac{\partial \Omega}{\partial k_\beta} k_{\beta,\alpha} = -\frac{\partial \Omega}{\partial x_\alpha}.$$

Since $k_{\alpha,\beta} = k_{\beta,\alpha}$, this may be modified to

$$k_{\alpha,t} + C_\beta k_{\alpha,\beta} = -\frac{\partial \Omega}{\partial x_\alpha}, \quad (4.20)$$

where

$$C_\beta = \frac{\partial \Omega}{\partial k_\beta}.$$

The group velocity \mathbf{C} defined in this way is the propagation velocity in (4.20) for the determination of \mathbf{k} . Equation (4.20) may be written in the characteristic form as

$$\frac{dk_\alpha}{dt} = -\frac{\partial \Omega}{\partial x_\alpha} \quad \text{on} \quad \frac{dx_\alpha}{dt} = \frac{\partial \Omega}{\partial k_\alpha}. \quad (4.21)$$

Note that \mathbf{k} is constant on each characteristic when the medium is homogeneous in \mathbf{x} , and then the characteristics are straight lines in the (\mathbf{x}, t) -space. Each value of \mathbf{k} propagates with the corresponding constant group velocity $\mathbf{C}(\mathbf{k})$. For inhomogeneous media this is no longer valid: the values of \mathbf{k} change as they propagate along the characteristics and the characteristics themselves become curves. However, since the medium is time-independent

$$\frac{d\omega}{dt} = \omega_{,t} + C_\beta \omega_{,\beta} = \frac{\partial \Omega}{\partial t} = 0,$$

the frequency remains constant along the characteristics.

It is interesting that equations (4.21) are identical with Hamilton's equations in mechanics if \mathbf{x} and \mathbf{k} are interpreted as coordinates and impulses while $\Omega(\mathbf{x}, \mathbf{k})$ is taken to be the Hamilton function (cf. Section 7.1). If instead of eliminating θ , we substitute for ω and \mathbf{k} in the dispersion relation $-\partial\theta/\partial t$ and $\partial\theta/\partial\mathbf{x}$, respectively, then the following equation holds true

$$\frac{\partial \theta}{\partial t} + \Omega\left(\mathbf{x}, \frac{\partial \theta}{\partial \mathbf{x}}\right) = 0.$$

This is nothing else but the Hamilton-Jacobi equation, with θ being regarded as the action [5] (see also exercise 7.2).

4.3 Elastic Waveguide

In signal processing it is often necessary to delay signals by sending them through an elastic waveguide which serves as the delay line. Due to the interaction of waves with the free boundaries, this device exhibits dispersive waves with infinite number of branches. The other interesting property of elastic waveguides is that the phase and group velocities may have different signs for some high-frequency thickness branches. Such waves are called "backward waves". Their presence plays a decisive role in posing the radiation conditions. Guided wave propagation is used intensively also in nondestructive testing as well as in seismology.

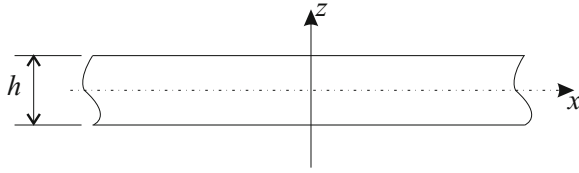

Fig. 4.7 Strip of thickness h

Equation of Motion. For simplicity, let us consider the most simple example of waveguide, namely an elastic strip of thickness h , as shown in Figure 4.7. The cartesian coordinate system is selected, with (x, y) -plane coinciding with the middle surface of the strip. The face surfaces of the strip are given by $z = \pm h/2$. Assuming that the strip is made of a homogeneous isotropic elastic material, we write down the three-dimensional equations of its motion in terms of the displacements u_α

$$\rho u_{\alpha,tt} = (\lambda + \mu) u_{\beta,\beta\alpha} + \mu u_{\alpha,\beta\beta},$$

where λ and μ are Lamé constants. The traction-free boundary conditions on the face surfaces $z = \pm h/2$ read

$$\sigma_{\alpha z}|_{z=\pm h/2} = [\lambda u_{\beta,\beta} \delta_{\alpha z} + \mu(u_{\alpha,z} + u_{z,\alpha})]|_{z=\pm h/2} = 0.$$

We non-dimensionalize these equations by introducing the following variables

$$\bar{t} = \frac{tc_s}{h}, \quad (\bar{x}, \bar{y}, \bar{z}) = \frac{1}{h}(x, y, z),$$

where $c_s = \sqrt{\mu/\rho}$ is the speed of shear wave in an infinite solid. The equations of motion and the boundary conditions then take the dimensionless form

$$\begin{aligned} u_{\alpha,tt} &= (1 + \gamma) u_{\beta,\beta\alpha} + u_{\alpha,\beta\beta}, \\ [\gamma u_{\beta,\beta} \delta_{\alpha z} + (u_{\alpha,z} + u_{z,\alpha})]|_{z=\pm 1/2} &= 0, \end{aligned} \quad (4.22)$$

where $\gamma = \lambda/\mu$ and the bars are dropped for short.

Rayleigh-Lamb Dispersion Relation. Let us look for particular solutions of the boundary-value problem (4.22) in the form

$$u_\alpha = f_\alpha(z) e^{i(kx - \omega t)}.$$

Substituting this into the equations (4.22), we obtain two uncoupled systems.

For the shear waves (SH-waves)³ with

$$u_y = f_y(z) e^{i(kx - \omega t)}, \quad u_x = u_z = 0,$$

³ This terminology arose in seismology where the boundary surface is usually horizontal.

we have

$$\begin{aligned} f_y'' + p_2^2 f_y &= 0, \\ f_y'|_{z=\pm 1/2} &= 0, \end{aligned} \quad (4.23)$$

where the prime denotes the derivative with respect to z and

$$p_2^2 = \omega^2 - k^2.$$

The eigenvalue problem (4.23) yields the following eigenfunctions:

$$\begin{aligned} f_y &= a \cos 2\pi n z, \quad p_2 = 2\pi n, \quad \text{for SS-waves,} \\ f_y &= a \sin \pi(2n+1)z, \quad p_2 = \pi(2n+1), \quad \text{for AS-waves,} \end{aligned} \quad (4.24)$$

where SS stands for the symmetric shear waves, while AS for the antisymmetric shear waves.

We turn now to the second case, for which

$$u_x = f_x(z)e^{i(kx-\omega t)}, \quad u_z = f_z(z)e^{i(kx-\omega t)}, \quad u_y = 0.$$

Substitution of these formulas into equations (4.22)₁ gives

$$\begin{aligned} f_x'' + (1+\gamma)ikf_z' + (\omega^2 - \eta^{-2}k^2)f_x &= 0, \\ \eta^{-2}f_z'' + (1+\gamma)ikf_x' + (\omega^2 - k^2)f_z &= 0, \end{aligned} \quad (4.25)$$

where

$$\eta^{-2} = \gamma + 2 = \frac{\lambda + 2\mu}{\mu}, \quad \eta = \sqrt{\frac{\mu}{\lambda + 2\mu}} = \sqrt{\frac{1-2\nu}{2-2\nu}},$$

with ν being Poisson's ratio. The boundary conditions (4.22)₂ become

$$\begin{aligned} \eta^{-2}f_z' + \gamma ikf_x &= 0, \\ f_x' + ikf_z &= 0. \end{aligned} \quad (4.26)$$

The eigenvalue problem (4.25) and (4.26) admits the symmetric and antisymmetric solutions of the type

$$\begin{aligned} f_x(z) - \text{even}, \quad f_z(z) - \text{odd} \quad (\text{L-waves}), \\ f_x(z) - \text{odd}, \quad f_z(z) - \text{even} \quad (\text{F-waves}). \end{aligned}$$

The characteristic equation of the system (4.25)

$$\det \begin{vmatrix} s^2 + \omega^2 - \eta^{-2}k^2 & (1+\gamma)iks \\ (1+\gamma)iks & \eta^{-2}s^2 + \omega^2 - k^2 \end{vmatrix} = 0$$

has four roots given by

$$s_{1,2} = \pm i p_1, \quad p_1 = \sqrt{\eta^2 \omega^2 - k^2},$$

$$s_{3,4} = \pm i p_2, \quad p_2 = \sqrt{\omega^2 - k^2}.$$

Therefore the symmetric solutions corresponding to longitudinal waves (L-waves) read

$$f_x = i(Ak \cos p_1 z + B p_2 \cos p_2 z),$$

$$f_z = -A p_1 \sin p_1 z + B k \sin p_2 z, \quad (4.27)$$

where A and B are still unknown constants. The four boundary conditions on $z = \pm 1/2$ reduce to two equations in A and B

$$(k^2 - p_2^2) \cos \frac{p_1}{2} A + 2k p_2 \cos \frac{p_2}{2} B = 0,$$

$$-2k p_1 \sin \frac{p_1}{2} A + (k^2 - p_2^2) \sin \frac{p_2}{2} B = 0. \quad (4.28)$$

Equating the determinant to zero, we obtain from (4.28) the dispersion relation

$$(k^2 - p_2^2)^2 \sin(p_2/2) \cos(p_1/2) + 4k^2 p_1 p_2 \sin(p_1/2) \cos(p_2/2) = 0. \quad (4.29)$$

This is the Rayleigh-Lamb dispersion relation for the propagation of the L-waves in this waveguide. From (4.28) we also obtain the amplitude ratio

$$\frac{A}{B} = -\frac{2k p_2 \cos(p_2/2)}{(k^2 - p_2^2) \cos(p_1/2)} = \frac{(k^2 - p_2^2) \sin(p_2/2)}{2k p_1 \sin(p_1/2)}.$$

Next, we consider the antisymmetric solutions corresponding to flexural waves (F-waves), which are given by

$$f_x = i(Ck \sin p_1 z - D p_2 \sin p_2 z),$$

$$f_z = C p_1 \cos p_1 z + D k \cos p_2 z, \quad (4.30)$$

where C and D are unknown constants. The traction-free boundary conditions at $z = \pm 1/2$ reduce also in this case to two equations for C and D

$$(k^2 - p_2^2) \sin \frac{p_1}{2} C - 2k p_2 \sin \frac{p_2}{2} D = 0,$$

$$2k p_1 \cos \frac{p_1}{2} C + (k^2 - p_2^2) \cos \frac{p_2}{2} D = 0.$$

Since the determinant should vanish to guarantee nontrivial solutions, we derive from here the following dispersion relation for the F-waves:

$$(k^2 - p_2^2)^2 \cos(p_2/2) \sin(p_1/2) + 4k^2 p_1 p_2 \cos(p_1/2) \sin(p_2/2) = 0. \quad (4.31)$$

This is the Rayleigh-Lamb dispersion relation for F-waves. We also obtain the equation for the ratio C/D

$$\frac{C}{D} = \frac{2kp_2 \sin(p_2/2)}{(k^2 - p_2^2) \sin(p_1/2)} = -\frac{(k^2 - p_2^2) \cos(p_2/2)}{2kp_1 \cos(p_1/2)}.$$

Mention that both equations (4.29) and (4.31) can be combined in a single equation

$$\frac{\tan(p_2/2)}{\tan(p_1/2)} = - \left[\frac{4p_1 p_2 k^2}{(k^2 - p_2^2)^2} \right]^{\pm 1}, \quad \begin{cases} + & \text{for L-waves,} \\ - & \text{for F-waves.} \end{cases} \quad (4.32)$$

Dispersion Curves. The dispersion relations (4.24), (4.29) and (4.31) were obtained independently by Rayleigh and Lamb [28, 44]. However, due to their complexity, the full analysis of branches of the dispersion curves in the (k, ω) -plane, as well as branches with imaginary and complex wave number k , was completed much later (see, for instance, [31]). We provide here the detailed asymptotic analysis and numerical simulations of these equations.

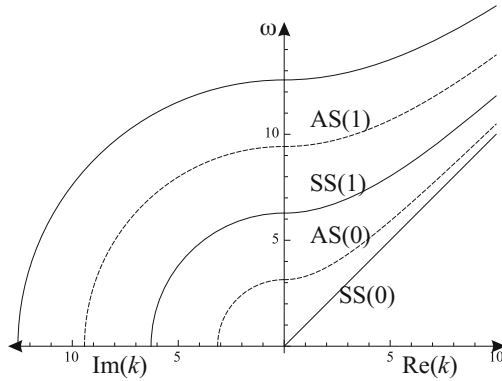

Fig. 4.8 Dispersion curves of shear waves

For SH-waves the dispersion relation (4.24) shows that for each number $n = 0, 1, 2, \dots$ there are two branches

$$\omega = \pm \sqrt{\pi^2(2n)^2 + k^2}, \quad \text{for SS}(n)\text{-waves,}$$

$$\omega = \pm \sqrt{\pi^2(2n + 1)^2 + k^2}, \quad \text{for AS}(n)\text{-waves.}$$

The plus or minus sign indicates the direction of wave propagation. All SS- and AS-waves, except SS(0), are dispersive. At some real and fixed wave number k the eigenfunctions (4.24) form a complete orthogonal basis in the space of regular functions of z . Thus, the series of Fourier's integrals over all branches solves the initial value problem for the infinite strip with arbitrary regular initial displacement $u_{y0}(x, z)$ and velocity $v_{y0}(x, z)$. The solvability of signaling problem for a semi-infinite strip requires the inclusion of solutions with imaginary k . We observe that

the wave number k becomes imaginary for $\omega < \omega_c$, where $\omega_c = 2n\pi$ for SS(n) and $\omega_c = (2n + 1)\pi$ for AS(n). The frequency ω_c at which the group velocity becomes zero is called a cutoff frequency. Thus, the free propagation of the corresponding branch does not occur at frequencies lower than the cutoff frequency. Several branches of the dispersion curves are plotted in Fig. 4.8. Since the dispersion curves for real k are symmetrical about the ω -axis, the (k, ω) -half-plane with negative real k can be replaced by the (k, ω) -half-plane with positive imaginary k . Looking at the dispersion curves we recognize that at a given fixed frequency there are only a finite number of real k for SH-waves. Thus, we have only a finite number of propagating waves. To satisfy arbitrary boundary conditions for a semi-infinite strip at $x = 0$ in the signaling problem, we have to combine these propagating waves with an infinite number of solutions having imaginary k and corresponding to non-propagating modes. These modes describe vibrations which are localized near the edge of the strip.

We turn now to the longitudinal and flexural waves characterized by the dispersion relation (4.32) and consider the case of real k . Depending on whether (k, ω) is found in the regions I, II, or III, as shown in Figure 4.9, we may have p_1, p_2 being both imaginary, one imaginary and one real, or both real, respectively. The dispersion relations will alter their forms accordingly. In the region I $p_1 = iq_1, p_2 = iq_2$, where $q_1 = \sqrt{k^2 - \eta^2\omega^2}, q_2 = \sqrt{k^2 - \omega^2}$. The dispersion relations take the form

$$\frac{\tanh(q_2/2)}{\tanh(q_1/2)} = \left[\frac{4q_1q_2k^2}{(k^2 + q_2^2)^2} \right]^{\pm 1}, \quad \begin{cases} + & \text{for L-waves,} \\ - & \text{for F-waves.} \end{cases}$$

To find the asymptote of the first F-branch for small k and ω we expand the hyperbolic tangent

$$\tanh x = x \left(1 - \frac{1}{3}x^2 + \dots \right).$$

Retaining the first two terms, we reduce the dispersion relation for F-waves to

$$\frac{q_2 \left(1 - \frac{1}{3}(q_2/2)^2 \right)}{q_1 \left(1 - \frac{1}{3}(q_1/2)^2 \right)} = \frac{(k^2 + q_2^2)^2}{4q_1q_2k^2}.$$

We put this in the form

$$-(k^2 - q_2^2)^2 = \frac{1}{3}k^2q_2^4 - \frac{1}{12}q_1^2(k^2 + q_2^2)^2.$$

Expanding this and keeping the terms according to Newton's rule, we obtain the asymptotic formula

$$\omega^2 = \frac{1}{6(1-\nu)}k^4 + O(k^6).$$

which agrees with that of the plate theory.

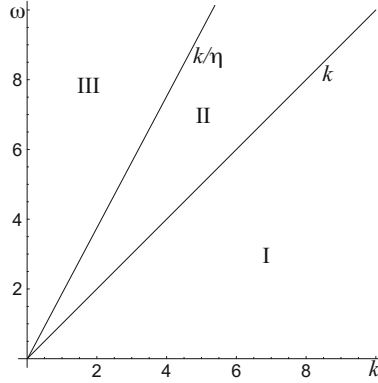

Fig. 4.9 Three regions of the (k, ω) -plane

In the region II $p_1 = iq_1$, and equation (4.32) becomes

$$\frac{\tan(p_2/2)}{\tanh(q_1/2)} = \pm \left[\frac{4q_1 p_2 k^2}{(k^2 - p_2^2)^2} \right]^{\pm 1}, \quad \begin{cases} + & \text{for L-waves,} \\ - & \text{for F-waves.} \end{cases}$$

The lowest F-branch has no roots in this region. For the lowest L-branch we replace $\tan x \sim x$ and $\tanh x \sim x$ giving

$$\frac{p_2}{q_1} = \frac{4q_1 p_2 k^2}{(k^2 - p_2^2)^2}, \quad \text{or} \quad (k^2 - p_2^2)^2 = 4k^2 q_1^2.$$

Keeping the main terms in this equation we find that

$$\omega^2 = \frac{2}{1 - \nu} k^2 + O(k^4),$$

which agrees again with the plate theory [31].

Let us consider now the high-frequency branches of L- and F-waves. We are interested in the asymptotic behavior of the dispersion curves near the cutoff frequencies in the long-wave range $k \ll 1$. Since the dispersion curves are in the range $\omega \sim 1$ and $k \ll 1$, we have to analyze (4.29) and (4.31) in the region III of the (k, ω) -plane (see Figure 4.9). Setting $k = 0$ in (4.29), we see that the cutoff frequencies ω_c of L-waves are the roots of the equation

$$\sin \frac{\omega_c}{2} \cos \frac{\eta \omega_c}{2} = 0.$$

It implies that

$$\omega_c = 2\pi n, \quad \text{or} \quad \omega_c = \frac{\pi(2n + 1)}{\eta}.$$

The first family of roots corresponds to the cutoff frequencies of the series L_{\parallel} , the second one to the cutoff frequencies of the series L_{\perp} .

We turn to the branch $L_{\parallel}(n)$. To study the asymptotics of the dispersion curve near the cutoff frequency $\omega_c = 2\pi n$ we introduce the notation

$$\omega^2 = \omega_c^2 + y, \quad k^2 = x,$$

with x and y being small quantities. Expanding the left-hand side of equation (4.29) in the Taylor series of x and y and keeping only the principal terms in accordance with Newton's rule, we obtain

$$\omega_c^4 \cos \frac{\omega_c}{2} \frac{1}{4\omega_c} (y-x) \cos \frac{\eta\omega_c}{2} + 4x\eta\omega_c^2 \sin \frac{\eta\omega_c}{2} \cos \frac{\omega_c}{2} = 0.$$

Solving this with respect to y we get finally

$$\omega^2 = \omega_c^2 + \left(1 - \frac{16\eta \tan(\eta\omega_c/2)}{\omega_c}\right)k^2.$$

For the branch $L_{\perp}(n)$ with $\omega_c = \pi(2n+1)/\eta$ we obtain after performing the same operations

$$\omega^2 = \omega_c^2 + \left(\frac{1}{\eta^2} + \frac{16 \cot(\omega_c/2)}{\omega_c}\right)k^2.$$

Analogously, the asymptotic analysis of the Rayleigh-Lamb equation for F-waves leads to the following cutoff frequencies

$$\omega_c = \frac{2\pi n}{\eta}, \quad \text{or} \quad \omega_c = \pi(2n+1).$$

The first family of roots corresponds to the cutoff frequencies of the series F_{\perp} , the second one to the cutoff frequencies of the series F_{\parallel} . Similar asymptotic formulas for the corresponding dispersion curves in the long-wave range can also be obtained (see exercise 4.9).

In the above consideration we implicitly assume the value of η such that $\cos(\eta\pi n) \neq 0$. In the opposite case the coefficient at y in the approximate dispersion equation vanishes, and the above equation fails to provide the true asymptotics for long waves. Consider, for definiteness, the branch $L_{\parallel}(n)$ and introduce the new variables

$$\omega = \omega_c + y, \quad k^2 = x.$$

Expanding (4.29) in x and y and keeping their principal terms, we arrive at

$$-\omega_c^4 \cos \frac{\omega_c}{2} \sin \frac{\eta\omega_c}{2} \frac{\eta}{4} y^2 + 4x\eta\omega_c^2 \sin \frac{\eta\omega_c}{2} \cos \frac{\omega_c}{2} = 0,$$

yielding

$$\omega = \omega_c \pm \frac{4}{\omega_c}k.$$

One can see from the last equation that the group velocity $v_g = d\omega/dk$ of $L_{\parallel}(1)$ does not vanish at $k = 0$, but is equal to $\pm 2/\pi$, and consequently, the wave packet moves without deformation in the long-wave range. It is also interesting to observe that, for $\nu = 1/3$, the cutoff frequency of the branch $L_{\parallel}(1)$ coincides with that of the branch $L_{\perp}(0)$.

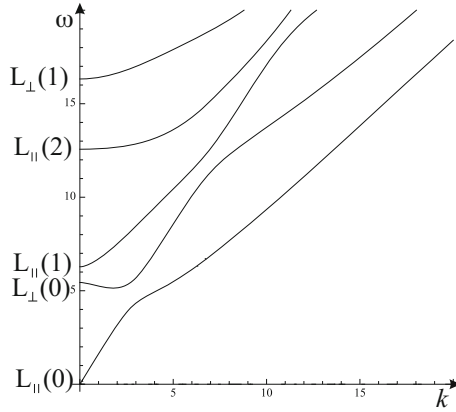

Fig. 4.10 Dispersion curves of L-waves

Figs. 4.10 and 4.11 show the dispersion curves of L- and F-waves, respectively, for $\nu = 0.25$. Since the dispersion curves are symmetrical about the ω -axis, it is enough to show them in the first quadrant $k > 0, \omega > 0$. The lowest branches of these waves, $L_{\parallel}(0)$ and $F_{\perp}(0)$, begin from the origin and approach asymptotically the straight line $\omega = v_r k$ as $k \rightarrow \infty$, where $v_r = c_r/c_s$ is the dimensionless Rayleigh's wave speed which may be obtained as the positive real root of the equation

$$v_r^6 - 8v_r^4 + (24 - 16\eta^2)v_r^2 + 16(\eta^2 - 1) = 0.$$

All other branches are high-frequency thickness branches which begin at the corresponding cutoff frequencies and approach the straight line $\omega = k$ as $k \rightarrow \infty$. This means that the wave speed of these branches approaches that of the shear waves in an infinite solid, $c_s = \sqrt{\mu/\rho}$, as $k \rightarrow \infty$. It is interesting that the dispersion curves of some branches, say $L_{\perp}(0)$ or $F_{\parallel}(1)$, have negative curvatures and slopes near $k = 0$. We can recognize this also from the asymptotic formulas in the long-wave range derived previously for these branches. Indeed, let us consider, for example, the branch $L_{\perp}(0)$ for which $\omega_c = \pi/\eta$ and

$$\omega^2 = (\pi/\eta)^2 + \left(\frac{1}{\eta^2} + \frac{16 \cot(\omega_c/2)}{\omega_c}\right)k^2$$

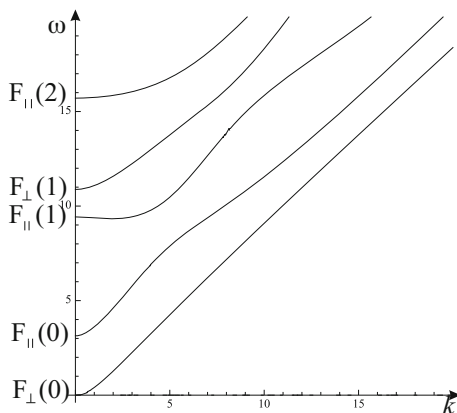

Fig. 4.11 Dispersion curves of F-waves

for small k . If $\nu = 0.25$, then the coefficient at k^2 is negative and equal to

$$\frac{1}{\eta^2} + \frac{16 \cot(\omega_c/2)}{\omega_c} = -3.56865.$$

Consequently, the phase and group velocities have different signs in the long-wave range. Such waves carry energy in one direction but their phase surfaces appear to propagate in the opposite direction. Because of this property they are called “backward waves”.

Now let us consider the solvability of the initial value problem for an infinite waveguide and for arbitrary initial conditions. This solvability is guaranteed if the eigenfunctions found in (4.27) and (4.30) form a complete orthonormal basis in the space of vector-valued functions of z . To show that this is the case we rewrite the equations (4.25) in the operator form

$$\mathbf{L}\mathbf{f} = \lambda\mathbf{f},$$

where $\lambda = \omega^2$ and

$$\mathbf{f} = \begin{pmatrix} f_x(z) \\ f_z(z) \end{pmatrix}, \quad \mathbf{L}\mathbf{f} = \begin{pmatrix} -f_{x,zz} - (1 + \gamma)ikf_{z,z} + \eta^{-2}k^2f_x \\ -\eta^{-2}f_{z,zz} - (1 - \gamma)ikf_{x,z} + k^2f_z \end{pmatrix}.$$

It is easy to check the following property: if k is real, then the operator \mathbf{L} is Hermitian in the sense that

$$\langle \mathbf{g}, \mathbf{L}\mathbf{f} \rangle - \langle \mathbf{L}\mathbf{g}, \mathbf{f} \rangle = \int_{-1/2}^{1/2} [\mathbf{g}^* \cdot \mathbf{L}\mathbf{f} - \mathbf{f}^* \cdot \mathbf{L}\mathbf{g}] dz = 0$$

for arbitrary two vector-valued functions $\mathbf{f}(z)$ and $\mathbf{g}(z)$ satisfying the boundary conditions (4.26). Therefore, the eigenvalue problem (4.25) and (4.26) has a discrete spectrum and the eigenfunctions form a complete orthonormal basis in this function

space [23]. Thus, the series of Fourier’s integrals over all branches solves the initial value problem for the infinite strip with arbitrary regular initial displacements $\mathbf{u}_0(x, z)$ and velocities $\mathbf{v}_0(x, z)$.

The signaling problem is much more challenging, where many questions remain still open.⁴ Similar to the SH-waves, we have at a given fixed frequency only a finite number of real k for L- or F-waves as seen from Figs. 4.10 and 4.11. But in contrast to the SH-waves, the number of solutions with imaginary k is also finite. It can be shown, however, that there exists a countable number of solutions with the complex conjugate k . To satisfy arbitrary boundary conditions for a semi-infinite strip at $x = 0$ in the signaling problem, we have to combine the propagating waves with those solutions having imaginary and complex conjugate k . These modes describe vibrations which are localized near the edge of the strip. The other issue is the radiation conditions. Since the backward waves are present, we propose to select among propagating waves only those with positive group velocities which transport the energy from the edge of the strip to infinity. In Fig. 4.12 presenting the dispersion curves of branches $L_{\parallel}(0)$ and $L_{\perp}(0)$ near the cutoff frequency $\omega_c = \pi/\eta$ the only waves corresponding to points A, B, C are selected if the frequency of the sent signal is fixed at the level indicated by the horizontal line.

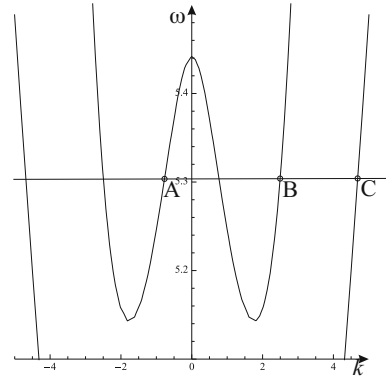

Fig. 4.12 Selected waves

4.4 Energy Method

Energy Balance Equation. Since waves transport energy from one part of the medium to another, the energy balance of its fixed part must involve energy flux entering the boundary. We want to derive the energy balance equation from Euler-Lagrange’s equations of motion (3.51) in the general case. Multiplying equations (3.51) with $u_{i,t}$ and summing up over i yields

$$u_{i,t} \frac{\partial}{\partial t} \frac{\partial L}{\partial u_{i,t}} + u_{i,t} \frac{\partial}{\partial x_{\alpha}} \frac{\partial L}{\partial u_{i,\alpha}} - u_{i,t} \frac{\partial L}{\partial u_i} = 0.$$

This equation can be transformed to

$$\frac{\partial}{\partial t} (u_{i,t} \frac{\partial L}{\partial u_{i,t}}) + \frac{\partial}{\partial x_{\alpha}} (u_{i,t} \frac{\partial L}{\partial u_{i,\alpha}}) - \frac{u_{i,tt}}{\partial u_{i,t}} \frac{\partial L}{\partial u_{i,t}} - \frac{u_{i,\alpha t}}{\partial u_{i,\alpha}} \frac{\partial L}{\partial u_{i,\alpha}} - \frac{u_{i,t}}{\partial u_i} \frac{\partial L}{\partial u_i} = 0.$$

⁴ For instance, the generalization of Saint-Venant’s principle to dynamics [15].

Since $u_{i,t}$ enter only the kinetic energy density which is quadratic with respect to $u_{i,t}$, the first term gives

$$\frac{\partial}{\partial t}(u_{i,t} \frac{\partial L}{\partial u_{i,t}}) = \frac{\partial}{\partial t}(u_{i,t} \frac{\partial K}{\partial u_{i,t}}) = \frac{\partial}{\partial t}(2K).$$

It is easy to see that the last three underlined terms lead to

$$-u_{i,t} \frac{\partial L}{\partial u_{i,t}} - u_{i,\alpha t} \frac{\partial L}{\partial u_{i,\alpha}} - u_{i,t} \frac{\partial L}{\partial u_i} = -\frac{\partial}{\partial t}(L).$$

So, we obtain the energy balance equation in the form

$$\frac{\partial}{\partial t}(K+U) + \frac{\partial}{\partial x_\alpha}(u_{i,t} \frac{\partial L}{\partial u_{i,\alpha}}) = 0. \quad (4.33)$$

The first term of (4.33) corresponds to the local change of the total energy density $E = K + U$, while its gradient term describes the energy transported by the wave motion. We therefore call $J_\alpha = u_{i,t} \frac{\partial L}{\partial u_{i,\alpha}}$ an energy flux.

Energy Propagation. To see how the energy is transported by the traveling waves let us first consider the 1-D Klein-Gordon equation (4.8)₁ which can be obtained from the following Lagrangian

$$L = \frac{1}{2}u_{,t}^2 - \frac{1}{2}(\omega_0^2 u^2 + c^2 u_{,x}^2).$$

According to the energy balance equation (4.33) we have the energy density

$$E = \frac{1}{2}u_{,t}^2 + \frac{1}{2}(\omega_0^2 u^2 + c^2 u_{,x}^2),$$

and the energy flux

$$J = -c^2 u_{,t} u_{,x}.$$

As we know, the asymptotically leading term of solution can be written in form of wave packet

$$u \simeq \text{Re}(Ae^{i\theta}) = a \cos(\theta + \phi),$$

where $a = |A|$, $\phi = \arg A$. The wave number $k = \theta_{,x}$, the frequency $\omega = -\theta_{,t}$, the initial phase ϕ , and the amplitude a are slowly changing functions of x and t . We use this asymptotic formula to compute the energy density and energy flux.

First we compute the term $\frac{1}{2}u_{,t}^2$ in the kinetic energy density

$$\frac{1}{2}u_{,t}^2 \simeq \frac{1}{2}\omega^2 a^2 \sin^2(\theta + \phi)$$

together with terms involving a_t and ϕ_t . Since a and ϕ are slowly changing functions of t , these terms can be neglected in the first approximation. Treating the other terms in the same way, we obtain for the energy density

$$E = \frac{1}{2}(\omega^2 + c^2k^2)a^2 \sin^2(\theta + \phi) + \frac{1}{2}\omega_0^2 a^2 \cos^2(\theta + \phi).$$

Similarly, the energy flux becomes

$$J = c^2\omega ka^2 \sin^2(\theta + \phi).$$

Now let us take the average of these quantities over one period. Since the average values of $\cos^2(\theta + \phi)$ and $\sin^2(\theta + \phi)$ over one period are equal to $1/2$, we get

$$\bar{E} = \frac{1}{4}(\omega^2 + c^2k^2 + \omega_0^2)a^2, \quad \bar{J} = \frac{1}{2}c^2\omega ka^2,$$

where bars over quantities denote their averaged values over one period. For Klein-Gordon equation the dispersion relation of waves propagating to the right reads

$$\omega = \sqrt{\omega_0^2 + c^2k^2}.$$

Therefore

$$\bar{E} = \frac{1}{2}(c^2k^2 + \omega_0^2)a^2, \quad \bar{J} = \frac{1}{2}c^2k\sqrt{\omega_0^2 + c^2k^2}a^2.$$

As we remember, the group velocity is

$$C(k) = \frac{d\Omega(k)}{dk} = \frac{c^2k}{\sqrt{\omega_0^2 + c^2k^2}},$$

so we get the following relation

$$\bar{J} = C(k)\bar{E}.$$

This relation turns out to be general.

Based on the above relation we are going to derive now the average energy balance equation

$$\bar{E}_t + (C\bar{E})_x = 0, \tag{4.34}$$

which can be interpreted as follows: the total average energy between any two group lines remains constant, or, in other words, energy propagates with the group velocity. For, if we consider the energy

$$E(t) = \int_{x_1(t)}^{x_2(t)} \bar{E} dx$$

between two points $x_1(t)$ and $x_2(t)$ moving with the group velocities $C(k_1)$, $C(k_2)$, respectively, then

$$\frac{dE}{dt} = \int_{x_1}^{x_2} \frac{\partial \bar{E}}{\partial t} dx + C_2 \bar{E}_2 - C_1 \bar{E}_1 = 0$$

if (4.34) is valid. Conversely, (4.34) is just the limit of the last equation as $x_2 - x_1 \rightarrow 0$.

To prove (4.34) we use the above formula for the average energy $\bar{E} = f(k)a^2$. Substituting it into the left-hand side of (4.34), we obtain

$$\bar{E}_{,t} + (C\bar{E})_{,x} = f(k)[(a^2)_{,t} + (Ca^2)_{,x}] + f'(k)a^2(k_{,t} + Ck_{,x}).$$

The last term on the right-hand side vanishes due to (4.17). By the same arguments given for \bar{E} , the first term must vanish too since the expression in the square brackets is the differential form of the result found in Section 4.2 that

$$Q(t) = \int_{x_1(t)}^{x_2(t)} a^2 dx$$

remains constant between any two group lines.

The established equations of energy propagation can easily be extended to the cases involving more unknown functions and to higher dimension. Consider, for example, the scalar Klein-Gordon equation in 3-D case corresponding to the Lagrangian

$$L = \frac{1}{2}u_{,t}^2 - \frac{1}{2}(\omega_0^2 u^2 + c^2 u_{,\alpha} u_{,\alpha}).$$

From (4.33) follows the energy balance equation

$$E_{,t} + J_{\alpha,\alpha} = 0,$$

where

$$E = \frac{1}{2}u_{,t}^2 + \frac{1}{2}\omega_0^2 u^2 + \frac{1}{2}c^2 u_{,\alpha} u_{,\alpha}, \quad J_\alpha = -c^2 u_{,t} u_{,\alpha}.$$

For a slowly varying wave packet $u = a \cos(\theta + \phi)$ the average values of E and J_α over one period are

$$\bar{E} = \frac{1}{4}(\omega^2 + c^2 k_\alpha k_\alpha + \omega_0^2) a^2, \quad \bar{J}_\alpha = \frac{1}{2} c^2 \omega k_\alpha a^2,$$

with $\mathbf{k} = \nabla \theta$ being the wave vector and $\omega = -\theta_{,t}$ the frequency. Since the dispersion relation for the first branch reads $\omega = \Omega(\mathbf{k}) = \sqrt{\omega_0^2 + c^2 |\mathbf{k}|^2}$, we see that

$$\bar{J}_\alpha = C_\alpha \bar{E},$$

where C_α is the group velocity

$$C_\alpha = \frac{\partial \Omega}{\partial k_\alpha} = \frac{c^2 k_\alpha}{\sqrt{\omega_0^2 + c^2 |\mathbf{k}|^2}}.$$

The average energy balance equation becomes

$$\bar{E}_{,t} + (C_\alpha \bar{E})_{,\alpha} = 0. \tag{4.35}$$

Equivalently, the total energy in any volume $V(t)$ moving with the group lines remains constant

$$\frac{d}{dt} \int_{V(t)} \bar{E} dx = \int_{V(t)} \bar{E}_{,t} dx + \int_{S(t)} \bar{E} C_\alpha n_\alpha da = 0,$$

where $S(t)$ is the boundary of $V(t)$, \mathbf{n} is the outward normal vector to $S(t)$, and $C_\alpha n_\alpha$ is its normal velocity. The last equation is obtained from (4.35) by integrating it over $V(t)$ and applying Gauss' theorem. Note that equation (4.35) can be presented in the characteristic form

$$\frac{d\bar{E}}{dt} = -\frac{\partial C_\alpha}{\partial x_\alpha} \bar{E} \quad \text{on} \quad \frac{dx_\alpha}{dt} = C_\alpha(\mathbf{k}).$$

So, the energy decays due to the divergence $C_{\alpha,\alpha}$ of the group lines. This effect is due lonely to the dispersion as there is no energy loss in this case.

It seems clear that these results should be established once and for all by general arguments without pursuing the detailed derivation each time. Such arguments are provided by the variational-asymptotic method.

Variational-Asymptotic Method. In this paragraph we are going to apply the variational-asymptotic method to quadratic functionals only. The generalization to non-linear problems will be given in Chapter 8.

Consider the variational problem in form of Hamilton's variational principle: find the extremal of the action functional

$$I[u_i(\mathbf{x}, t)] = \iint_R L(u_i, u_{i,\alpha}, u_{i,t}) dx dt, \tag{4.36}$$

where $R = V \times (t_0, t_1)$ is any finite and fixed region in $(d + 1)$ -dimensional space-time. We assume that u_i are prescribed at the boundary ∂R . We look for the extremal of this variational problem in form of a slowly varying wave packet⁵

$$u_i = \psi_i(\theta, \mathbf{x}, t), \tag{4.37}$$

where θ is a function of \mathbf{x} and t , ψ_i are periodic functions (with the period 2π) with respect to θ . Function θ plays the role of the phase, while $\theta_{,\alpha}$ and $-\theta_{,t}$ correspond to the wave vector k_α and the frequency ω , respectively. We assume that the characteristic scales Λ and T of changes of the functions $\theta_{,\alpha}$, $\theta_{,t}$ and $\psi_i(\theta, \mathbf{x}, t)|_{\theta=\text{const}}$

⁵ The amplitudes a_i appear later.

are considerably larger than the characteristic wavelength λ and period τ . The latter are defined as the best constants in the inequalities

$$|\theta_{,\alpha}| \leq \frac{2\pi}{\lambda}, \quad |\theta_{,t}| \leq \frac{2\pi}{\tau}, \quad (4.38)$$

while the former are the best constants in the inequalities

$$\begin{aligned} |\theta_{,\alpha\beta}| &\leq \frac{2\pi}{\lambda\Lambda}, & |\theta_{,\alpha t}| &\leq \frac{2\pi}{\lambda T}, & |\theta_{,\alpha t}| &\leq \frac{2\pi}{\tau\Lambda}, & |\theta_{,tt}| &\leq \frac{2\pi}{\tau T}, \\ |\partial_\alpha \psi_i| &\leq \frac{\bar{\psi}_i}{\Lambda}, & |\partial_t \psi_i| &\leq \frac{\bar{\psi}_i}{T}, & |\psi_{i,\theta}| &\leq \bar{\psi}_i, \end{aligned} \quad (4.39)$$

where $\partial_\alpha \psi_i = \partial \psi_i / \partial x_\alpha$ with $\theta = \text{const}$, and $\partial_t \psi_i = \partial \psi_i / \partial t$ with $\theta = \text{const}$. In other words, the wave vector $k_\alpha = \theta_{,\alpha}$, the frequency $\omega = -\theta_{,t}$, and functions ψ_i change little in one wavelength and one period. Therefore it makes sense to call θ “fast” variable as opposed to the “slow” variables x_α and t . Thus, in this variational problem we have two small parameters λ/Λ and τ/T .

We now calculate the derivatives $u_{i,\alpha}$ and $u_{i,t}$. According to (4.37) we have

$$u_{i,\alpha} = \partial_\alpha \psi_i + \psi_{i,\theta} \theta_{,\alpha}, \quad u_{i,t} = \partial_t \psi_i + \psi_{i,\theta} \theta_{,t}.$$

Because of (4.38) and (4.39) they can be approximately replaced by

$$u_{i,\alpha} \approx \psi_{i,\theta} \theta_{,\alpha}, \quad u_{i,t} \approx \psi_{i,\theta} \theta_{,t}.$$

Keeping in the action functional (4.36) the asymptotically principal terms, we obtain in the first approximation

$$I_0[\psi_i] = \iint_R L(\psi_i, \psi_{i,\theta} \theta_{,\alpha}, \psi_{i,\theta} \theta_{,t}) dx dt.$$

Let us decompose the domain R into the $(d+1)$ -dimensional strips bounded by the d -dimensional phase surfaces $\theta = 2\pi n$, $n = 0, \pm 1, \pm 2, \dots$. The integral over R can then be replaced by the sum of the integrals over the strips

$$\iint_R L dx dt = \sum \iint L(\psi_i, \psi_{i,\theta} \theta_{,\alpha}, \psi_{i,\theta} \theta_{,t}) \kappa d\theta d\zeta, \quad (4.40)$$

where ζ_α are the coordinates along the phase surface $\theta = \text{const}$, and κ is the Jacobian of transformation from x_α, t to θ, ζ_α . In the first approximation we may regard κ , $\theta_{,\alpha}$ and $\theta_{,t}$ in each strip as independent from θ . Therefore we obtain the same problem in each strip at the first step of the variational-asymptotic procedure: find the extremal of the functional

$$\bar{I}_0[\psi_i] = \int_0^{2\pi} L(\psi_i, \psi_{i,\theta} \theta_{,\alpha}, \psi_{i,\theta} \theta_{,t}) d\theta \quad (4.41)$$

among periodic functions $\psi_i(\theta)$ with the period 2π . Since the quantities $k_\alpha = \theta_{,\alpha}$ and $-\omega = \theta_{,t}$ change little within one strip, they are regarded as constants in the functional (4.41). The Euler-Lagrange's equation of this functional is a system of n second-order ordinary differential equations. Its solutions contain $2n$ arbitrary constants: n of them are determined from the conditions that $\psi_i(\theta)$ are 2π -periodic functions, the other n conditions can be chosen by fixing the amplitudes a_i as follows: $\max \psi_i = |a_i|$, where a_i are arbitrary real constants. We call this variational problem strip problem.

Let us denote by $2\pi\bar{L}$ the value of the functional (4.41) at its extremal. The quantity \bar{L} is a function of $a_i, \theta_{,\alpha}$ and $\theta_{,t}$. The sum (4.40), as $\lambda/\Lambda \rightarrow 0$ and $\tau/T \rightarrow 0$, can again be replaced by the integral

$$\iint_R \bar{L}(a_i, \theta_{,\alpha}, \theta_{,t}) dx dt. \quad (4.42)$$

Euler-Lagrange's equations of the average functional (4.42) read

$$\frac{\partial \bar{L}}{\partial a_i} = 0, \quad \frac{\partial}{\partial t} \frac{\partial \bar{L}}{\partial \theta_{,t}} + \frac{\partial}{\partial x_\alpha} \frac{\partial \bar{L}}{\partial \theta_{,\alpha}} = 0. \quad (4.43)$$

We will see that equations (4.43)₁ express the solvability condition for the strip problem leading to the dispersion relation, while (4.43)₂ is equivalent to the equation of energy propagation.

Notice that the variational approach described here was initiated by Whitham [53]. His arguments were based on some heuristic reasoning. The variational-asymptotic method in its most general formulation was proposed a little later by Berdichevsky [7]. It has then been applied to a wide class of variational problems having small parameters, including the homogenization of periodic and random structures leading to the cell problems, as well as approximate theories of shells and rods resulting in the thickness and cross-section problems (see [8, 31]). In all problems the variational-asymptotic method yielded the same results as the traditional asymptotic analysis of differential equations. But the former has some advantages compared with the latter. First, as we have to deal only with the variational equation, neglecting a small term in this equation means neglecting terms in several differential equations which are not always easy to be recognized as small ones. Second, no *ad hoc* assumptions about the order of smallness are needed. The order of smallness of terms in the asymptotic expansion is determined exclusively by minimizing the action functional. Thus, the more degrees of freedom and the more complicated the energy and dissipation we have to deal with, the more effective we may expect from the variational-asymptotic method compared with other traditional asymptotic methods as will be seen in the subsequent chapters.

Applications. Let us investigate the strip problem and the average variational problem on some concrete examples. As the first example we consider 1-D Klein-Gordon equation (4.8)₁ corresponding to the Lagrangian

$$L = \frac{1}{2}u_{,t}^2 - \frac{1}{2}(\omega_0^2 u^2 + c^2 u_{,x}^2).$$

Then the strip problem becomes: find the extremal of the functional

$$\bar{I}_0[\psi] = \int_0^{2\pi} \left[\frac{1}{2}(\omega^2 - c^2 k^2) \psi_{,\theta}^2 - \frac{1}{2} \omega_0^2 \psi^2 \right] d\theta$$

among 2π -periodic functions $\psi(\theta)$ satisfying the constraint $\max \psi = a$. The quantities $\omega = -\theta_{,t}$ and $k = \theta_{,x}$ are regarded as constants in this variational problem. Lagrange's equation implies that the 2π -periodic extremal can only be of the form

$$\psi(\theta) = a \cos(\theta + \phi),$$

provided $\omega^2 - c^2 k^2 = \omega_0^2$. The latter is the solvability condition for the strip problem. Substituting this back to \bar{I}_0 , we obtain the average Lagrangian

$$\bar{L}(a, \theta_{,x}, \theta_{,t}) = \frac{1}{4}(\theta_{,t}^2 - \omega_0^2 - c^2 \theta_{,x}^2) a^2.$$

Thus, the average Lagrangian does not depend on the initial phase ϕ . Let us analyze now Euler-Lagrange's equations of the average variational problem. Once these equations have been obtained, it is convenient to work with them in terms of a , k , ω :

$$\frac{\partial \bar{L}}{\partial a} = 0, \quad \frac{\partial}{\partial t} \frac{\partial \bar{L}}{\partial \omega} - \frac{\partial}{\partial x} \frac{\partial \bar{L}}{\partial k} = 0, \quad (4.44)$$

where

$$\bar{L} = G(\omega, k) a^2, \quad G(\omega, k) = \frac{1}{4}(\omega^2 - \omega_0^2 - c^2 k^2).$$

We see that the equation $\bar{L}_{,a} = 0$ is nothing else but the solvability condition for the strip problem which leads to the dispersion relation $G(\omega, k) = 0$. We can solve this relation with respect to ω to have the explicit form $\omega = \pm \Omega(k) = \pm \sqrt{\omega_0^2 + c^2 k^2}$. The second equation of (4.44) can be written as

$$\frac{\partial}{\partial t} (G_{,\omega} a^2) - \frac{\partial}{\partial x} (G_{,k} a^2) = 0.$$

Since $G(\Omega(k), k) = 0$, we have

$$G_{,\omega} \Omega'(k) + G_{,k} = 0,$$

and consequently,

$$C = \Omega'(k) = -\frac{G_{,k}}{G_{,\omega}}.$$

If we denote $G_{,\omega}(\Omega, k)$ by $g(k)$, then (4.44)₂ takes the form

$$(g(k) a^2)_{,t} + (g(k) C(k) a^2)_{,x} = 0.$$

It follows from the consistency condition $k_{,t} + \omega_{,x} = 0$ that

$$k_{,t} + Ck_{,x} = 0.$$

By using this kinematic relation, the factor $g(k)$ can be removed so that

$$(a^2)_{,t} + (Ca^2)_{,x} = 0.$$

This is nothing else but the equation of amplitude modulations. The equation governing energy propagation can easily be derived from here. We can also obtain the energy equation directly from balance equation (4.33) for the average variational problem.

Let us turn now to waves propagating in Timoshenko's beam with the Lagrangian given by (3.50). Introducing the unknown function u and the dimensionless variables according to

$$u = h\psi, \quad \bar{t} = tc_s/h, \quad \bar{x} = x/h,$$

we present the Lagrangian in the form (the bar is dropped for short)

$$L = \frac{1}{2}(w_{,t}^2 + \alpha u_{,t}^2) - \frac{1}{2}[su_{,x}^2 + \beta^2 \alpha(u + w_{,x})^2].$$

The strip problem becomes: find the extremal of the functional

$$\bar{I}_0[\psi_1, \psi_2] = \int_0^{2\pi} \left[\frac{1}{2}\omega^2(\psi_{1,\theta}^2 + \alpha\psi_{2,\theta}^2) - \frac{1}{2}sk^2\psi_{2,\theta}^2 - \frac{1}{2}\beta^2\alpha(\psi_2 + k\psi_{1,\theta})^2 \right] d\theta$$

among 2π -periodic functions $\psi_1(\theta)$, $\psi_2(\theta)$ satisfying the constraints $\max \psi_i = |a_i|$. In this functional $\omega = -\theta_{,t}$ and $k = \theta_{,x}$ are treated as constants. Lagrange's equations of this problem imply that the 2π -periodic extremal can only be of the form

$$\psi_1(\theta) = a_1 \cos(\theta + \phi), \quad \psi_2(\theta) = a_2 \sin(\theta + \phi).$$

The average Lagrangian becomes

$$\bar{L}(a_1, a_2, \theta_{,x}, \theta_{,t}) = \frac{1}{4}\theta_{,t}^2(a_1^2 + \alpha a_2^2) - \frac{1}{4}s\theta_{,x}^2 a_2^2 - \frac{1}{4}\beta^2\alpha(a_2 - \theta_{,x}a_1)^2.$$

The Euler-Lagrange's equations $\partial\bar{L}/\partial a_i = 0$ yield the system of two linear equations

$$\begin{aligned} (\omega^2 - \beta^2\alpha k^2)a_1 + \beta^2\alpha k a_2 &= 0, \\ \beta^2\alpha k a_1 + (\omega^2\alpha - sk^2 - \beta^2\alpha)a_2 &= 0, \end{aligned}$$

which has non-trivial solutions only if the determinant vanishes. This is the solvability condition for the strip problem which leads also to the dispersion relation

$$(\omega^2 - \beta^2\alpha k^2)(\omega^2\alpha - sk^2 - \beta^2\alpha) - \beta^4\alpha^2 k^2 = 0.$$

One can check that this equation coincides with the dispersion relation obtained by assuming the harmonic wave form. One can also find the amplitude ratio a_1/a_2 from this system. Finally, one can verify that the other Euler-Lagrange's equation implies the equation of energy propagation in this Timoshenko's beam (see exercise (4.10)).

It is not difficult now to rederive the geometrical optics considered in Section 4.1 from the variational-asymptotic method. The same can be said about weakly inhomogeneous media. This would be the case, for example, if the parameters ω_0 and c in the Klein-Gordon equation were functions of \mathbf{x} . The derivation of the strip problem remains unchanged. If the characteristic length of change of material parameters is much larger than the characteristic wavelength, then we can again regard them as constant in this strip problem. After finding the average Lagrangian the slow dependence of the material parameters on \mathbf{x} can be reinserted. The method can also be applied for the case of external forces which change slowly in time. In this case the Lagrangian depends explicitly on time, but this dependence can be ignored in the strip problem. However, the energy is no longer conserved. But notice that wave action is conserved in all cases.

4.5 Exercises

EXERCISE 4.1. Solve the 1-D wave equation with $c = 1$ and with the following initial conditions

$$u(x, 0) = 0, \quad u_t(x, 0) = \begin{cases} x + 1 & \text{for } x \in (-1, 0), \\ 1 - x & \text{for } x \in (0, 1), \\ 0 & \text{otherwise.} \end{cases}$$

Plot the solution at $t = 0.5$ and at $t = 10$.

Solution. According to the d'Alembert solution with $c = 1$

$$u(x, t) = f(x - t) + g(x + t).$$

Functions $f(x)$ and $g(x)$ should be found from the initial conditions

$$u(x, 0) = f(x) + g(x) = 0, \quad u_t(x, 0) = -f'(x) + g'(x) = v_0(x).$$

Thus, $f(x) = -g(x)$, while $g(x)$ satisfies the equation

$$g'(x) = \frac{1}{2}v_0(x) = \begin{cases} (x + 1)/2 & \text{for } x \in (-1, 0), \\ (1 - x)/2 & \text{for } x \in (0, 1), \\ 0 & \text{otherwise.} \end{cases}$$

Integrating this equation, we obtain for $g(x)$

$$g(x) = \begin{cases} 0 & \text{for } x < -1, \\ \frac{1}{4}(x+1)^2 & \text{for } x \in (-1, 0), \\ -\frac{1}{4}(x-1)^2 + \frac{1}{2} & \text{for } x \in (0, 1), \\ \frac{1}{2} & \text{for } x > 1. \end{cases}$$

The plot of this function is shown in Fig. 4.13.

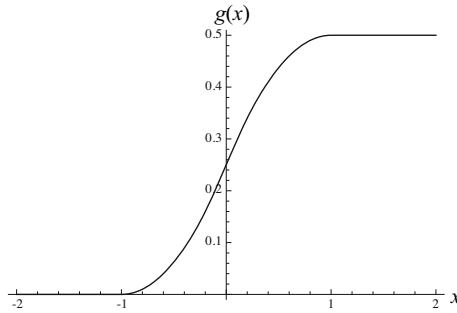

Fig. 4.13 Function $g(x)$

Substituting $g(x)$ and $f(x) = -g(x)$ into the d'Alembert solution, we can evaluate $u(x, t)$ and plot it at different instants of time. Figs. 4.14 and 4.15 show the solution at $t = 0.5$ and $t = 10$, respectively. We observe that, at large t , the solution is constant and equal to $1/2$ inside the interval $x \in (-t + 1, t - 1)$. Besides, there are two wave fronts of the width 2 propagating to the left and to the right with the velocity 1.

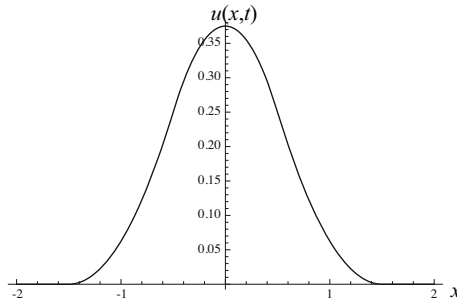

Fig. 4.14 Solution $u(x, t)$ at $t = 0.5$

EXERCISE 4.2. For waves propagating in an infinite elastic material which is homogeneous and isotropic we seek particular solutions in form of plane waves $\mathbf{u} = \mathbf{a}e^{i(\mathbf{k}\cdot\mathbf{x}-\omega t)}$. Show that there are two velocities of propagation given by

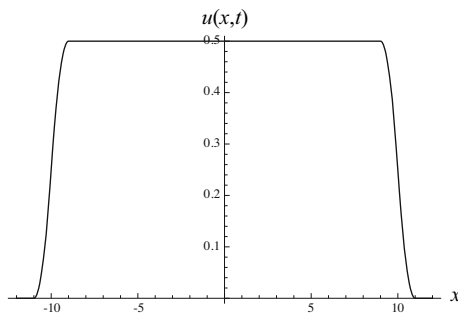

Fig. 4.15 Solution $u(x,t)$ at $t = 10$

$$c_d = \sqrt{\frac{\lambda + 2\mu}{\rho}}, \quad c_s = \sqrt{\frac{\mu}{\rho}},$$

corresponding to dilatational waves (\mathbf{a} is parallel to \mathbf{k}) and shear waves (\mathbf{a} is orthogonal to \mathbf{k}). Generalize this to homogeneous anisotropic materials.

Solution. Consider first the general case of infinite elastic material which is homogeneous and anisotropic. Then it is easy to show that the extremal of the action functional of this elastic material (see example 3.9) satisfies the Euler-Lagrange's equations

$$\rho u_{\alpha,\mu} - E_{\alpha\beta\gamma\delta} u_{\gamma,\delta\beta} = 0.$$

We look for the particular solutions of these equations in form of the plane wave

$$u_\alpha = a_\alpha e^{i(k_\mu x_\mu - \omega t)},$$

where \mathbf{a} and \mathbf{k} are constant vectors. Substituting this formula into the equations of motion and removing the non-zero factor $e^{i(k_\mu x_\mu - \omega t)}$, we get the eigenvalue problem

$$(-\rho \omega^2 \delta_{\alpha\gamma} + E_{\alpha\beta\gamma\delta} k_\delta k_\beta) a_\gamma = 0,$$

with $K_{\alpha\gamma} = E_{\alpha\beta\gamma\delta} k_\delta k_\beta$ being called the acoustic tensor.

We solve this eigenvalue problem for the case of isotropic material, for which

$$E_{\alpha\beta\gamma\delta} = \lambda \delta_{\alpha\beta} \delta_{\gamma\delta} + \mu (\delta_{\alpha\gamma} \delta_{\beta\delta} + \delta_{\alpha\delta} \delta_{\beta\gamma}).$$

The acoustic tensor becomes

$$K_{\alpha\gamma} = (\lambda + \mu) k_\alpha k_\gamma + \mu k^2 \delta_{\alpha\gamma},$$

where k is the magnitude of vector \mathbf{k} , that is, $k = |\mathbf{k}|$. Without limiting generality we may choose the x_1 -axis to be in the direction of vector \mathbf{k} , i.e., $\mathbf{k} = (k, 0, 0)$. Then the eigenvalue problem can be written in the matrix form

$$\begin{pmatrix} -\rho c^2 + \lambda + 2\mu & 0 & 0 \\ 0 & -\rho c^2 + \mu & 0 \\ 0 & 0 & -\rho c^2 + \mu \end{pmatrix} \begin{pmatrix} a_1 \\ a_2 \\ a_3 \end{pmatrix} = \begin{pmatrix} 0 \\ 0 \\ 0 \end{pmatrix},$$

with $c^2 = \omega^2/k^2$ being the phase velocity of wave propagation. There are one single eigenvalue and one double eigenvalue

$$c_1 = c_d = \sqrt{\frac{\lambda + 2\mu}{\rho}}, \quad c_2 = c_3 = c_s = \sqrt{\frac{\mu}{\rho}},$$

corresponding to three eigenvectors

$$\mathbf{a}_1 = \begin{pmatrix} 1 \\ 0 \\ 0 \end{pmatrix}, \quad \mathbf{a}_2 = \begin{pmatrix} 0 \\ 1 \\ 0 \end{pmatrix}, \quad \mathbf{a}_3 = \begin{pmatrix} 0 \\ 0 \\ 1 \end{pmatrix}.$$

Thus, the first eigenvector \mathbf{a}_1 points in the direction of \mathbf{k} and describes dilatational waves propagating with the velocity c_d . Two other eigenvectors \mathbf{a}_2 and \mathbf{a}_3 are orthogonal to \mathbf{k} and correspond to shear waves propagating with the velocity c_s which is the double eigenvalue.

EXERCISE 4.3. Consider the “balloon problem” in acoustics: the pressure inside a sphere of radius R_0 is $p_0 + P$ while the pressure outside is p_0 . The gas is initially at rest, and the balloon is burst at $t = 0$. The initial conditions for the velocity potential read

$$\varphi(\mathbf{x}, 0) = 0, \quad \varphi_t(\mathbf{x}, 0) = \begin{cases} -P/\rho_0 & 0 < r < R_0, \\ 0 & R_0 < r. \end{cases}$$

Find the change of pressure with time.

Solution. Due to the spherical symmetry, the velocity potential depends only on r and t , so

$$\varphi(r, t) = \frac{f(r - ct)}{r} + \frac{g(r + ct)}{r}.$$

Substituting this into the initial conditions, we have

$$f(r) + g(r) = 0, \quad f'(r) - g'(r) = \begin{cases} \frac{P}{\rho_0 c} & 0 < r < R_0, \\ 0 & R_0 < r. \end{cases}$$

These conditions determine f and g for positive values of their arguments. However, it is also necessary to evaluate function f with negative argument in the solution. The condition for that is obtained by requiring the absence of source at the origin

$$\lim_{r \rightarrow 0} r^2 \frac{\partial \varphi}{\partial r} = 0,$$

which implies

$$f(-ct) + g(ct) = 0 \quad \text{for } t > 0.$$

The last condition determines f for negative argument in terms of g for positive argument.

Solving the equations for f and g , we obtain

$$f(x) = \begin{cases} \frac{1}{4} \frac{P}{\rho_0 c} (x^2 - R_0^2) & |x| < R_0, \\ 0 & \text{otherwise,} \end{cases}$$

and

$$g(x) = \begin{cases} -\frac{1}{4} \frac{P}{\rho_0 c} (x^2 - R_0^2) & 0 < x < R_0, \\ 0 & R_0 < x. \end{cases}$$

With these functions we find the pressure difference

$$p - p_0 = -\rho_0 \varphi_{,t} = \frac{P}{2r} [(r - ct)F(r - ct) + (r + ct)G(r + ct)],$$

where

$$F(x) = \begin{cases} 1 & -R_0 < x < R_0, \\ 0 & \text{otherwise,} \end{cases}$$

and

$$G(x) = \begin{cases} 1 & 0 < x < R_0, \\ 0 & R_0 < x. \end{cases}$$

EXERCISE 4.4. Search for particular solutions in form of plane waves and derive the dispersion relation for 1-D waves propagating in Timoshenko's beam, the dimensionless Lagrangian of which is

$$L = \frac{1}{2}(w_{,t}^2 + \alpha u_{,t}^2) - \frac{1}{2}[su_{,x}^2 + \beta^2 \alpha (u + w_{,x})^2].$$

Plot the dispersion curves and study their asymptotic behavior as $k \rightarrow 0$ and $k \rightarrow \infty$.

Solution. Let $u_1 = w$ and $u_2 = u$. From the Euler-Lagrange's equations

$$\frac{\partial}{\partial t} \frac{\partial L}{\partial u_{i,t}} + \frac{\partial}{\partial x} \frac{\partial L}{\partial u_{i,x}} - \frac{\partial L}{\partial u_i} = 0, \quad i = 1, 2,$$

we derive

$$\begin{aligned} w_{,tt} - \beta^2 \alpha (u + w_{,x})_{,x} &= 0, \\ \alpha u_{,tt} - su_{,xx} + \beta^2 \alpha (u + w_{,x}) &= 0. \end{aligned}$$

We look for the particular solutions of these equations in form of plane waves

$$\begin{pmatrix} w(x, t) \\ u(x, t) \end{pmatrix} = \begin{pmatrix} a_1 \\ a_2 \end{pmatrix} e^{i(kx - \omega t)},$$

where a_1 and a_2 are constants. Substituting this Ansatz into the equations of motion and removing the common non-zero factor $e^{i(kx-\omega t)}$, we obtain

$$\begin{pmatrix} -\omega^2 + \beta^2 \alpha k^2 & -\beta^2 \alpha i k \\ \beta^2 \alpha i k & -\alpha \omega^2 + s k^2 + \beta^2 \alpha \end{pmatrix} \begin{pmatrix} a_1 \\ a_2 \end{pmatrix} = \begin{pmatrix} 0 \\ 0 \end{pmatrix}.$$

Nontrivial solutions exist if the determinant of the matrix vanishes yielding the dispersion relation

$$(-\omega^2 + \beta^2 \alpha k^2)(-\alpha \omega^2 + s k^2 + \beta^2 \alpha) - \beta^4 \alpha^2 k^2 = 0.$$

Thus, for each real k there are two real and positive roots of this dispersion relations corresponding to two different branches of the dispersion curves. To plot the dispersion curves we use the following parameters

$$\alpha = \frac{1}{2} \left(\frac{\pi^2}{24} \right)^2, \quad \beta = \pi, \quad s = \frac{1}{6(1-\nu)},$$

with ν being Poisson’s ratio (see [31]). The plot of the dispersion curves for $\nu = 0.31$ (dashed lines) are shown in Fig. 4.16. We also plot the dispersion curves of the two first branches of F-waves according to Rayleigh-Lamb dispersion relation (solid lines). The comparison shows quite good agreement in the long-wave range.

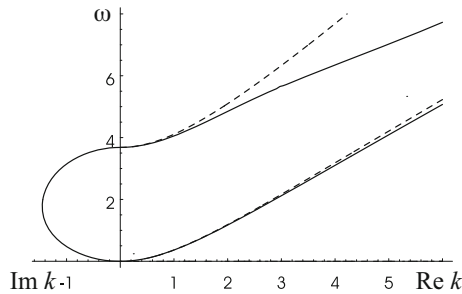

Fig. 4.16 Dispersion curves of flexural waves propagating in a beam: a) 1-D Timoshenko beam theory: dashed line and b) 3-D theory: solid line

In the long-wave range ($k \ll 1$) the asymptotic analysis of dispersion relation yields the following formula

$$\omega^2 = s k^4 + O(k^6)$$

for the low-frequency branch, and

$$\omega^2 = \beta^2 + \left(\alpha \beta^2 + \frac{s}{\alpha} \right) k^2 + O(k^4)$$

for the high-frequency thickness vibrations.

In the short-wave range ($k \rightarrow \infty$) the dispersion curves approach the asymptotes

$$\omega = \beta\sqrt{\alpha k} \quad \text{and} \quad \omega = \sqrt{\frac{s}{\alpha}}k,$$

respectively.

EXERCISE 4.5. Solve the linearized Korteweg-de Vries equation with $\alpha = 0$, $\beta = 1$ and with the initial condition $u(x, 0) = e^{-x^2}$. Compute Fourier's integral numerically⁶ and plot the solution at $t = 1$.

Solution. Using the Fourier transform, we find that

$$u(x, t) = \int_{-\infty}^{\infty} \psi(k) e^{ikx - i\Omega(k)t} dk,$$

where, for the linearized KdV equation with $\alpha = 0$, $\beta = 1$,

$$\Omega(k) = -k^3.$$

Function $\psi(k)$ should be determined from the initial condition

$$\int_{-\infty}^{\infty} \psi(k) e^{ikx} dk = u(x, 0) = e^{-x^2}.$$

Applying the Fourier transform to both sides, we obtain

$$\psi(k) = \frac{1}{2\pi} \int_{-\infty}^{\infty} e^{-x^2} e^{-ikx} dx = \frac{1}{2\sqrt{\pi}} e^{-k^2/4}.$$

Thus, the problem reduces to computing the integral

$$u(x, t) = \int_{-\infty}^{\infty} \frac{1}{2\sqrt{\pi}} e^{-k^2/4} e^{i(kx + k^3 t)} dk.$$

This can be done numerically by using the Fourier series package in *Mathematica*. Due to the highly oscillatory integrand, we choose the maximum number of recursive subdivisions to be 100 to achieve the required accuracy. The plot of $u(x, t)$ at $t = 1$ is shown in Fig. 4.17. We see the dispersive waves propagating in the negative direction of the x -axis. For $x > 0$ the solution decays quickly and does not have the oscillatory character. This behavior remains valid also for the later instants of time.

EXERCISE 4.6. Use the method of stationary phase to find the asymptotically leading term of the solution obtained in the previous exercise as $t \rightarrow \infty$ at fixed x/t . Compare this asymptotic solution with the exact one at $t = 10$.

⁶ Since the integrand is highly oscillatory, the accuracy is achieved only by increasing the maximum number of recursive subdivisions.

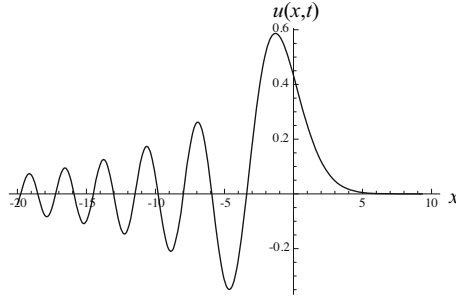

Fig. 4.17 Solution $u(x,t)$ at $t = 1$

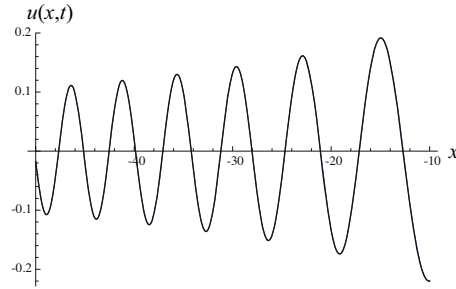

Fig. 4.18 Asymptotic solution $u(x,t)$ at $t = 10$

Solution. For the large time asymptotics the method of stationary phase can be used instead of numerical integration. In our case we rewrite the solution in the form

$$u(x,t) = \int_{-\infty}^{\infty} \psi(k) e^{-i\chi(k)t} dk,$$

where

$$\chi(k) = -k^3 - k \frac{x}{t}.$$

As we know, the main contributions to the integral come from the neighborhoods of stationary points of $\chi(k)$

$$\chi'(k) = -3k^2 - \frac{x}{t} = 0.$$

Thus, for $x > 0$ there is no stationary point, and the solution at fixed x/t and large t must be nearly zero. For $x < 0$ there are two stationary points given by

$$k_1(x,t) = \sqrt{\frac{-x}{3t}} \quad \text{and} \quad k_2(x,t) = -k_1(x,t) = -\sqrt{\frac{-x}{3t}}.$$

At these stationary points

$$\psi(k_s) = \frac{1}{2\sqrt{\pi}} e^{x/12t}.$$

Taking into account that $\chi''(k_s) = -6k_s$, we find that

$$\begin{aligned} u(x, t) &\simeq \frac{1}{2\sqrt{\pi}} e^{x/12t} \sqrt{\frac{2\pi}{6tk_1}} e^{ik_1x + ik_1^3t + \frac{i\pi}{4}} + \frac{1}{2\sqrt{\pi}} e^{x/12t} \sqrt{\frac{2\pi}{6tk_1}} e^{-ik_1x - ik_1^3t - \frac{i\pi}{4}} \\ &\simeq e^{x/12t} \sqrt{\frac{1}{3tk_1}} \cos(k_1x + k_1^3t + \pi/4). \end{aligned}$$

Fig. 4.18 plots the exact solution in terms of Fourier's integrals computed numerically at time $t = 10$ and the above asymptotic solution at the same time, where the results are nearly identical in the region $x < 0$.

EXERCISE 4.7. Show that the lowest branches of the dispersion curves of F- and L-waves in an elastic waveguide approach the straight line $\omega = v_r k$ as $k \rightarrow \infty$.

Solution. Consider first the lowest branch of L-waves which must be determined by the dispersion relation

$$\frac{\tanh(q_2/2)}{\tanh(q_1/2)} = \frac{4q_1q_2k^2}{(k^2 + q_2^2)^2},$$

where

$$q_1 = \sqrt{k^2 - \eta^2\omega^2}, \quad q_2 = \sqrt{k^2 - \omega^2}, \quad \eta = \sqrt{\frac{\mu}{\lambda + 2\mu}} = \sqrt{\frac{1 - 2\nu}{2 - 2\nu}}.$$

Introducing the dimensionless phase velocity $v = \omega/k$, we can represent the above equation in the form

$$\frac{\tanh(k\sqrt{1 - v^2}/2)}{\tanh(k\sqrt{1 - \eta^2v^2}/2)} = \frac{\sqrt{1 - \eta^2v^2}\sqrt{1 - v^2}}{(1 - v^2/2)^2}.$$

As $k \rightarrow \infty$ the left-hand side must go to 1 for any finite and fixed $v \in (0, 1)$. Thus, v must be determined from the equation

$$\frac{\sqrt{1 - \eta^2v^2}\sqrt{1 - v^2}}{(1 - v^2/2)^2} = 1.$$

This equation has a unique solution $v_r = c_r/c_s$ in the range $v \in (0, 1)$, where c_r is the Rayleigh wave speed (see exercise 4.9).

For the lowest branch of F-waves the dispersion relation is obtained from the above equation by inverting the right-hand side, so $\omega/k \rightarrow v_r$ also in the limit $k \rightarrow \infty$.

EXERCISE 4.8. Prove that all high-frequency thickness branches of F- and L-waves in an elastic waveguide approach the line $\omega = k$ from above as $k \rightarrow \infty$.

Solution. As seen from the Rayleigh-Lamb equation for L-waves, when $v = 1/\eta$ there is an infinite number of roots given by

$$k = \frac{2n\pi}{\sqrt{1/\eta^2 - 1}}, \quad n = 1, 2, \dots$$

This means that there is an infinite number of branches of the dispersion curves crossing the straight line $\omega = k/\eta$ and entering the region II as k becomes large. The dispersion relation for L-waves in this region read

$$\frac{\tan(k\sqrt{v^2 - 1}/2)}{\tanh(k\sqrt{1 - \eta^2 v^2}/2)} = \frac{\sqrt{1 - \eta^2 v^2} \sqrt{v^2 - 1}}{(1 - v^2/2)^2}.$$

For large k function $\tanh(k\sqrt{1 - \eta^2 v^2}/2)$ is close to 1, so the above equation can be replaced by

$$\tan(k\sqrt{v^2 - 1}/2) = \frac{\sqrt{1 - \eta^2 v^2} \sqrt{v^2 - 1}}{(1 - v^2/2)^2}.$$

This equation has an infinite number of roots for each fixed $v \in (1, 1/\eta)$. From this observation it follows that any straight line $\omega = vk$, with $v > 1$, cannot be an asymptote to any of the branches. Indeed, if the n -th branch would have v as the limiting speed, the straight line $\omega = vk$ would intersect at most $n - 1$ branches (the dispersion curves cannot intersect each other), but this contradicts the fact that there are infinitely many dispersion curves intersecting this line. Thus, v must approach 1. In this limit the above equation can further be simplified to take the form

$$\tan(k\sqrt{v^2 - 1}/2) = 4\sqrt{1 - \eta^2} \sqrt{v^2 - 1}.$$

Let $\varepsilon = \sqrt{v^2 - 1}$. Solving this equation, we find that, to the first order of ε

$$k \sim \frac{2n\pi}{\varepsilon} \sim \frac{2\pi n}{\sqrt{\omega^2/k^2 - 1}} \implies \omega^2 - k^2 = (2\pi n)^2.$$

These equations of hyperbolas describe the asymptotic behavior of the dispersion curves as k goes to infinity. The proof for F-waves can be done in a similar manner.

EXERCISE 4.9. Rayleigh surface wave. Determine the velocity of wave propagating near the free surface of an isotropic elastic half-space.

Solution. Let us choose the coordinate system such that the elastic medium occupies the domain $z \leq 0$ with the plane $z = 0$ as its free boundary. We write the dimensionless equations of motion

$$u_{\alpha,tt} = (1 + \gamma)u_{\beta,\beta\alpha} + u_{\alpha,\beta\beta}$$

and the traction free boundary conditions

$$[\gamma u_{\beta,\beta} \delta_{\alpha z} + (u_{\alpha,z} + u_{z,\alpha})]_{z=0} = 0$$

as in (4.22), where h is an arbitrary length. We look for the solution in form of the surface wave propagating in the x -direction

$$u_x = \hat{f}_x e^{sz} e^{i(kx - \omega t)}, \quad u_y = 0, \quad u_z = \hat{f}_z e^{sz} e^{i(kx - \omega t)},$$

with \hat{f}_x and \hat{f}_z being constants. Since the solution must decay exponentially as $z \rightarrow -\infty$, we choose s to be real and positive. Substituting this Ansatz into the equations of motion, we obtain the system

$$\begin{pmatrix} s^2 + \omega^2 - \eta^{-2}k^2 & (1 + \gamma)iks \\ (1 + \gamma)iks & \eta^{-2}s^2 + \omega^2 - k^2 \end{pmatrix} \begin{pmatrix} \hat{f}_x \\ \hat{f}_z \end{pmatrix} = \begin{pmatrix} 0 \\ 0 \end{pmatrix}.$$

The condition of vanishing determinant yields two real positive roots

$$s_1 = \sqrt{k^2 - \eta^2 \omega^2}, \quad s_2 = \sqrt{k^2 - \omega^2},$$

corresponding to two eigenvectors

$$\begin{pmatrix} \hat{f}_x \\ \hat{f}_z \end{pmatrix} = \begin{pmatrix} ik \\ s_1 \end{pmatrix}, \quad \begin{pmatrix} \hat{f}_x \\ \hat{f}_z \end{pmatrix} = \begin{pmatrix} is_2 \\ k \end{pmatrix},$$

provided (k, ω) is found in the region I. Thus, the general solution reads

$$\begin{aligned} u_x &= i(Ak e^{s_1 z} + Bs_2 e^{s_2 z}) e^{i(kx - \omega t)}, \\ u_z &= (As_1 e^{s_1 z} + Bk e^{s_2 z}) e^{i(kx - \omega t)}. \end{aligned}$$

The traction-free boundary conditions at $z = 0$ yield two equations for A and B

$$\begin{aligned} (\eta^{-2}s_1^2 - \gamma k^2)A + ks_2(\eta^{-2} - \gamma)B &= 0, \\ 2ks_1A + (s_2^2 + k^2)B &= 0. \end{aligned}$$

Equating the determinant to zero, we obtain from here the relation

$$(2k^2 - \omega^2)^2 - 4k^2 \sqrt{k^2 - \eta^2 \omega^2} \sqrt{k^2 - \omega^2} = 0.$$

Introducing the dimensionless velocity of wave propagation $v = \omega/k$, we bring this relation to the form

$$(2 - v^2)^2 - 4\sqrt{1 - \eta^2 v^2} \sqrt{1 - v^2} = 0,$$

or, equivalently,

$$v^6 - 8v^4 + (24 - 16\eta^2)v^2 + 16(\eta^2 - 1) = 0.$$

It is easy to see that this cubic equation with respect to v^2 has a unique root in the range $v \in (0, 1)$. The plot of $v = c_r/c_s$ versus Poisson's ratio is shown in Fig. 4.19. As the Poisson ratio changes from zero to $1/2$, c_r/c_s changes from 0.874 to 0.955.

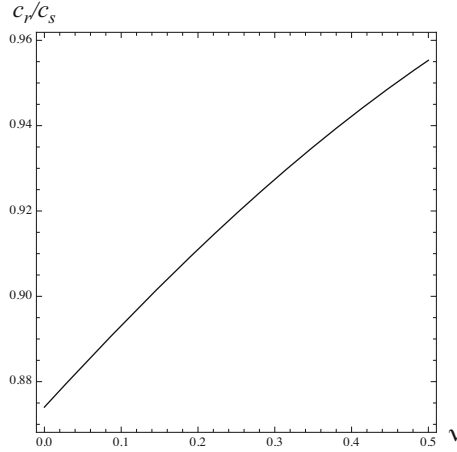

Fig. 4.19 The dimensionless velocity of Rayleigh surface wave c_r/c_s versus Poisson's ratio

EXERCISE 4.10. Derive the equation of energy propagation for Timoshenko's beam using the variational-asymptotic method and compare it with the similar equation obtained via averaging the energy balance equation.

Solution. The Euler-Lagrange's equation of the average variational problem

$$\frac{\partial}{\partial t} \frac{\partial \bar{L}}{\partial \omega} - \frac{\partial}{\partial x} \frac{\partial \bar{L}}{\partial k} = 0$$

implies the equation of energy propagation

$$(\omega \bar{L}_{,\omega} - \bar{L})_{,t} + (-\omega \bar{L}_{,k})_{,x} = 0,$$

where $\omega \bar{L}_{,\omega} - \bar{L}$ is the average total energy density and $-\omega \bar{L}_{,k}$ is the average energy flux (see exercise 4.12). For the Timoshenko beam we have

$$\bar{L}(a_1, a_2, k, \omega) = \frac{1}{4} \omega^2 (a_1^2 + \alpha a_2^2) - \frac{1}{4} s k^2 a_2^2 - \frac{1}{4} \beta^2 \alpha (a_2 - k a_1)^2.$$

Thus, the average total energy density reads

$$\bar{E} = \omega \bar{L}_{,\omega} - \bar{L} = \frac{1}{4} \omega^2 (a_1^2 + \alpha a_2^2) + \frac{1}{4} s k^2 a_2^2 + \frac{1}{4} \beta^2 \alpha (a_2 - k a_1)^2,$$

while the average energy flux equals

$$\bar{J} = -\omega \bar{L}_{,k} = \frac{1}{2} s a_2^2 k \omega - \frac{1}{2} \beta^2 \alpha (a_2 - k a_1) a_1 \omega.$$

Let us show that the same equation can also be derived by averaging the exact energy balance equation (4.33). For Timoshenko's beam theory the total energy density is

$$E = K + U = \frac{1}{2}(w_{,t}^2 + \alpha u_{,t}^2) + \frac{1}{2}[su_{,x}^2 + \beta^2 \alpha (u + w_{,x})^2],$$

while the energy flux equals

$$J = u_{i,t} \frac{\partial L}{\partial u_{i,x}} = -\beta^2 \alpha w_{,t}(u + w_{,x}) - su_{,t}u_{,x}.$$

The asymptotically leading terms of solution can be written in form of wave packet

$$w \simeq a_1 \cos(\theta + \phi), \quad u \simeq a_2 \sin(\theta + \phi),$$

where a_1 and a_2 are amplitudes of w and u , respectively. The wave number $k = \theta_{,x}$, the frequency $\omega = -\theta_{,t}$, the initial phase ϕ , and the amplitudes a_1 and a_2 are slowly changing functions of x and t . We use these formulas to compute the asymptotically leading terms of the total energy density and the energy flux.

First we compute the kinetic energy density

$$\frac{1}{2}(w_{,t}^2 + \alpha u_{,t}^2) \simeq \frac{1}{2}[\omega^2 a_1^2 \sin^2(\theta + \phi) + \alpha \omega^2 a_2^2 \cos^2(\theta + \phi)]$$

together with terms involving $a_{i,t}$ and $\phi_{,t}$. Since a_i and ϕ are slowly changing functions of t , these terms can be neglected in the first approximation. Treating the other terms in the same way, we obtain for the total energy density

$$E = \frac{1}{2}[\omega^2 a_1^2 \sin^2(\theta + \phi) + \alpha \omega^2 a_2^2 \cos^2(\theta + \phi)] \\ + \frac{1}{2}[sk^2 a_2^2 \cos^2(\theta + \phi) + \beta^2 \alpha (a_2 - a_1 k)^2 \sin^2(\theta + \phi)].$$

Similarly, the energy flux becomes

$$J = -\beta^2 \alpha \omega a_1 (a_2 - ka_1) \sin^2(\theta + \phi) + s \omega k a_2^2 \cos^2(\theta + \phi).$$

Now let us take the average of these quantities over one period. Since the average values of $\cos^2(\theta + \phi)$ and $\sin^2(\theta + \phi)$ over one period are equal to $1/2$, we get

$$\bar{E} = \frac{1}{4} \omega^2 (a_1^2 + \alpha a_2^2) + \frac{1}{4} s k^2 a_2^2 + \frac{1}{4} \beta^2 \alpha (a_2 - ka_1)^2,$$

and

$$\bar{J} = \frac{1}{2} s a_2^2 k \omega - \frac{1}{2} \beta^2 \alpha (a_2 - ka_1) a_1 \omega,$$

which coincide with the above equations obtained from the variational-asymptotic method.

EXERCISE 4.11. Solve the strip problem for 3-D Klein-Gordon equation

$$u_{,tt} + \omega_0^2 u = c^2 \Delta u$$

to find the average Lagrangian, the dispersion relation, and the equation of energy propagation.

Solution. For 3-D Klein-Gordon equation corresponding to the Lagrangian

$$L = \frac{1}{2} u_{,t}^2 - \frac{1}{2} (\omega_0^2 u^2 + c^2 u_{,\alpha} u_{,\alpha}),$$

the strip problem becomes: find the extremal of the functional

$$\bar{I}_0[\psi] = \int_0^{2\pi} \left[\frac{1}{2} (\omega^2 - c^2 k_\alpha k_\alpha) \psi_{,\theta}^2 - \frac{1}{2} \omega_0^2 \psi^2 \right] d\theta$$

among 2π -periodic functions $\psi(\theta)$ satisfying the constraint $\max \psi = a$. The quantities $\omega = -\theta_{,t}$ and $\mathbf{k} = \nabla \theta$ are regarded as constants in this variational problem. Lagrange's equation implies that the 2π -periodic extremal can only be of the form

$$\psi(\theta) = a \cos(\theta + \phi),$$

provided $\omega^2 - c^2 |\mathbf{k}|^2 = \omega_0^2$, where $|\mathbf{k}|^2 = k_\alpha k_\alpha$. The latter is the solvability condition for the strip problem. Using this solution, we compute the average Lagrangian

$$\bar{L}(a, \theta_{,\alpha}, \theta_{,t}) = \frac{1}{4} (\theta_{,t}^2 - \omega_0^2 - c^2 \theta_{,\alpha} \theta_{,\alpha}) a^2.$$

Euler-Lagrange's equations of the average variational problem, in terms of a , \mathbf{k} , and ω , read

$$\frac{\partial \bar{L}}{\partial a} = 0, \quad \frac{\partial}{\partial t} \frac{\partial \bar{L}}{\partial \omega} - \frac{\partial}{\partial x_\alpha} \frac{\partial \bar{L}}{\partial k_\alpha} = 0.$$

Let us write $\bar{L} = G(\omega, \mathbf{k}) a^2$, where $G(\omega, \mathbf{k}) = \frac{1}{4} (\omega^2 - \omega_0^2 - c^2 |\mathbf{k}|^2)$. We see that the equation $\bar{L}_{,a} = 0$ is nothing else but the solvability condition $G(\omega, \mathbf{k}) = 0$ for the strip problem which is equivalent to the dispersion relation

$$\omega^2 = \omega_0^2 + c^2 |\mathbf{k}|^2.$$

We can solve this relation with respect to ω to have the explicit form $\omega = \pm \Omega(\mathbf{k}) = \pm \sqrt{\omega_0^2 + c^2 |\mathbf{k}|^2}$. The second equation can be written as

$$\frac{\partial}{\partial t} (G_{,\omega} a^2) - \frac{\partial}{\partial x_\alpha} (G_{,k_\alpha} a^2) = 0.$$

Since $G(\Omega(\mathbf{k}), \mathbf{k}) = 0$, we have

$$G_{,\omega} \Omega_{,k_\alpha} + G_{,k_\alpha} = 0,$$

and consequently,

$$C_\alpha = \Omega_{,k_\alpha} = -\frac{G_{,k_\alpha}}{G_{,\omega}}.$$

If we denote $G_{,\omega}(\Omega(\mathbf{k}), \mathbf{k})$ by $g(\mathbf{k})$, then the second equation takes the form

$$(g(\mathbf{k})a^2)_{,t} + (g(\mathbf{k})C_\alpha a^2)_{,\alpha} = 0.$$

It follows from the consistency condition $k_{\alpha,t} + \omega_{,\alpha} = 0$ that

$$k_{\alpha,t} + C_\beta k_{\beta,\alpha} = 0.$$

By using this kinematic relation, the factor $g(\mathbf{k})$ can be removed so that

$$(a^2)_{,t} + (C_\alpha a^2)_{,\alpha} = 0.$$

This is nothing else but the equation of amplitude modulations. The equation governing energy propagation reads (see the next exercise)

$$(\omega \bar{L}_{,\omega} - \bar{L})_{,t} + (-\omega \bar{L}_{,k_\alpha})_{,\alpha} = 0.$$

With $\bar{L} = G(\omega, \mathbf{k})a^2$ we get

$$\bar{E} = \omega \bar{L}_{,\omega} - \bar{L} = (\omega G_{,\omega} - G)a^2,$$

and

$$\bar{J}_\alpha = -\omega \bar{L}_{,k_\alpha} = -\omega G_{,k_\alpha} a^2 = \omega G_{,\omega} C_\alpha a^2.$$

Substituting these formulas into the equation of energy propagation and taking into account the dispersion relation $G(\Omega(\mathbf{k}), \mathbf{k}) = 0$, we easily see that it is equivalent to the equation of amplitude modulations.

EXERCISE 4.12. Derive the following equations

$$\begin{aligned} (\omega \bar{L}_{,\omega} - \bar{L})_{,t} + (-\omega \bar{L}_{,k_\alpha})_{,\alpha} &= 0, \\ (k_\alpha \bar{L}_{,\omega})_{,t} + (-k_\alpha \bar{L}_{,k_\beta} + \bar{L} \delta_{\alpha\beta})_{,\beta} &= 0, \end{aligned}$$

for homogeneous media, which can be interpreted as the energy and “wave momentum” equations, respectively. What happens if \bar{L} depends on the slow variables x_α and t ?

Solution. The derivation of the energy equation is quite similar to that given at the beginning of Section 4.4. Starting from the average Euler-Lagrange’s equation

$$\frac{\partial}{\partial t} \frac{\partial \bar{L}}{\partial \omega} - \frac{\partial}{\partial x_\alpha} \frac{\partial \bar{L}}{\partial k_\alpha} = 0$$

and multiplying it with ω , we obtain

$$\omega(\bar{L}_{,\omega})_{,t} - \omega(\bar{L}_{,k_\alpha})_{,\alpha} = 0.$$

Rearrange terms to get

$$(\omega \bar{L}_{,\omega})_t - (\omega \bar{L}_{,k_\alpha})_{,\alpha} - \omega_t \bar{L}_{,\omega} + \omega_{,\alpha} \bar{L}_{,k_\alpha} = 0.$$

Replacing $\omega_{,\alpha}$ in the last term by $-k_{\alpha,t}$ in accordance with the consistency condition and taking into account the dispersion relations $\bar{L}_{,a_i} = 0$, we see that the last two terms give $-\bar{L}_{,t}$ since, according to the chain rule of differentiation,

$$\bar{L}_{,t} = \frac{\partial \bar{L}}{\partial \theta_t} \theta_{,tt} + \frac{\partial \bar{L}}{\partial \theta_{,\alpha}} \theta_{,\alpha t} + \frac{\partial \bar{L}}{\partial a_i} a_{i,t} = \omega_t \bar{L}_{,\omega} + k_{\alpha,t} \bar{L}_{,k_\alpha}.$$

Thus,

$$(\omega \bar{L}_{,\omega} - \bar{L})_t + (-\omega \bar{L}_{,k_\alpha})_{,\alpha} = 0.$$

Since $\omega \bar{L}_{,\omega}$ is the average kinetic energy density \bar{K} , the expression in the square brackets of the first term is the average total energy density, while $-\omega \bar{L}_{,k_\alpha}$ is the average energy flux. So, this equation is the equation of energy propagation.

The “wave momentum” equation can be derived by multiplying the average Euler-Lagrange’s equation with k_α

$$k_\alpha (\bar{L}_{,\omega})_t - k_\alpha (\bar{L}_{,k_\beta})_{,\beta} = 0.$$

Rearranging terms to get

$$(k_\alpha \bar{L}_{,\omega})_t - (k_\alpha \bar{L}_{,k_\beta})_{,\beta} - k_{\alpha,t} \bar{L}_{,\omega} + k_{\alpha,\beta} \bar{L}_{,k_\beta} = 0.$$

Replacing $k_{\alpha,t}$ by $-\omega_{,\alpha}$ and keeping in mind the dispersion relations, we reduce the last two terms to $\bar{L}_{,\alpha}$, so

$$(k_\alpha \bar{L}_{,\omega})_t + (-k_\alpha \bar{L}_{,k_\beta} + \bar{L} \delta_{\alpha\beta})_{,\beta} = 0.$$

If the average Lagrangian depends on the slow variables x_α (weakly inhomogeneous media) and t (slowly changing external forces), the energy and wave momentum equations change. In the case of slow dependence on t , the energy equation becomes

$$(\omega \bar{L}_{,\omega} - \bar{L})_t + (-\omega \bar{L}_{,k_\alpha})_{,\alpha} = -\partial_t \bar{L},$$

where $\partial_t \bar{L}$ denotes the partial time derivative of \bar{L} at fixed ω and k_α . In case of slow dependence on x_α , the wave momentum equation reads

$$(k_\alpha \bar{L}_{,\omega})_t + (-k_\alpha \bar{L}_{,k_\beta} + \bar{L} \delta_{\alpha\beta})_{,\beta} = \partial_\alpha \bar{L},$$

where $\partial_\alpha \bar{L}$ denotes the partial derivative of \bar{L} with respect to x_α at fixed ω and k_α .

Part II
Nonlinear Theory

Chapter 5

Autonomous Single Oscillator

This chapter studies finite amplitude vibrations of the autonomous mechanical systems having one degree of freedom. The character of solutions depends strongly on the type of the system. The solution methods may range from phase portrait and Lindstedt-Poincaré method for conservative systems up to Bogoliubov-Mitropolsky method for systems with weak dissipation.

5.1 Conservative Oscillator

Differential Equation of Motion. As before, Hamilton’s variational principle with the Lagrange function $L(q, \dot{q})$, q and \dot{q} being the generalized coordinate and velocity, is our tool for deriving the equation of motion of conservative systems. However, in contrast to the linear theory, we will see that the kinetic energy may now depend on q as well, and the potential energy is no longer quadratic with respect to q . We consider three simple examples.

EXAMPLE 5.1. Mass-spring oscillator. A point-mass m moves horizontally under the action of a non-linear spring (see Fig. 5.1). Derive the equation of motion for this oscillator.

Like the oscillator considered in example 1.1 the kinetic energy is given by $K = \frac{1}{2}m\dot{x}^2$. Concerning the potential energy of the non-linear spring we first consider the most general case, for which $U(x)$ is an arbitrary smooth function. Then Lagrange’s equation reads

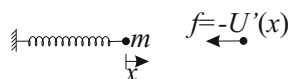

Fig. 5.1 Mass-spring oscillator

$$m\ddot{x} - f(x) = 0, \quad f(x) = -\frac{dU}{dx}.$$

The spring force $f(x)$ is called a restoring force. However, it is quite reasonable to assume that the potential energy of the spring deviates only slightly from that of the linear spring, i.e.,

$$U(x) = \frac{1}{2}kx^2 + \frac{1}{4}\alpha\frac{k}{l_0^2}x^4,$$

where l_0 is the original length of the spring and α a small parameter. If $\alpha > 0$, the spring is called hardening; on the contrary if $\alpha < 0$ it is called softening. Lagrange's equation becomes

$$m\ddot{x} + kx + \alpha\frac{k}{l_0^2}x^3 = 0.$$

Dividing this equation by kl_0 and rewriting it in terms of the dimensionless function $\bar{x} = x/l_0$ and the dimensionless time $\bar{t} = \sqrt{k/mt}$, we obtain¹

$$\ddot{x} + x + \alpha x^3 = 0. \tag{5.1}$$

Equation (5.1) is known as Duffing's equation.

EXAMPLE 5.2. Derive the equation of motion of the mathematical pendulum considered in example 1.2.

As has been shown already in that example, the Lagrange function is

$$L(\varphi, \dot{\varphi}) = \frac{1}{2}ml^2\dot{\varphi}^2 - mgl(1 - \cos\varphi),$$

but now φ is no longer small. Thus, the finite amplitude vibrations of this pendulum are described by the equation

$$\ddot{\varphi} + \omega_0^2 \sin\varphi = 0, \quad \omega_0 = \sqrt{\frac{g}{l}}.$$

By expanding $\sin\varphi$ in the Taylor series about $\varphi = 0$ and keeping the terms up to φ^3 we obtain the approximate equation

$$\ddot{\varphi} + \omega_0^2\left(\varphi - \frac{\varphi^3}{6}\right) = 0,$$

which can be transformed to (5.1) with $\alpha = -1/6$.

EXAMPLE 5.3. A point-mass m is constrained to move along a frictionless path represented by a smooth curve $y = y(x)$ in the (x, y) -plane under the action of gravity (see Fig. 5.2). Derive the equation of motion.

¹ The bar is dropped for short.

This is the typical example of systems with holonomic constraints. Any holonomic constraint like that of the curve $y = y(x)$ can be realized by a strong potential energy $U(x, y)$ which forces the point-mass to move along the path. In the limit when the potential energy goes to infinity in the neighborhood of the path, one gets the Lagrange function evaluated under this constraint [5]. Using in our example x (or, equivalently, the arc-length s along the curve) as the coordinate of the point-mass, we find its constrained velocity along the path

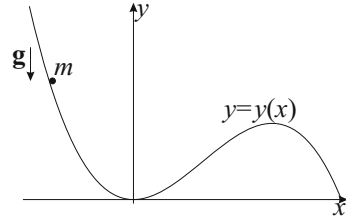

Fig. 5.2 Motion of point-mass along a path

$$v = \dot{s} = \sqrt{1 + y'^2} \dot{x}.$$

Thus, the kinetic energy of the point-mass equals

$$K(x, \dot{x}) = \frac{1}{2} m v^2 = \frac{1}{2} m (\sqrt{1 + y'^2} \dot{x})^2.$$

Observe that the kinetic energy depends not only on \dot{x} , but also on x through the function $y(x)$. Choosing the zero level at $y = 0$, the potential energy is given by

$$U(x) = mgh = mgy(x).$$

Therefore, Lagrange's equation yields

$$\frac{d}{dt} (m \sqrt{1 + y'^2} \dot{x}) + mg \frac{y'}{\sqrt{1 + y'^2}} = 0.$$

Phase Portrait. As we know from Section 2.4, for conservative oscillators the total energy remains constant during the motion

$$K(x, \dot{x}) + U(x) = E_0.$$

This first integral describes the level curves (phase curves) in the phase plane (x, y) , where $y = \dot{x}$. Consider for instance example 5.1 for which

$$\frac{1}{2} m \dot{x}^2 + U(x) = E_0.$$

Solving this equation with respect to \dot{x} , we find explicitly

$$\dot{x} = \pm \sqrt{\frac{2}{m}} \sqrt{E_0 - U(x)}. \tag{5.2}$$

The plus or minus sign depends on whether we are in the upper half or lower half of the phase plane.

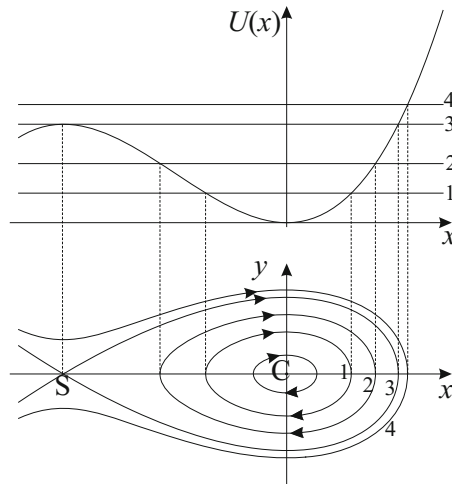

Fig. 5.3 Potential energy and phase portrait of conservative oscillator

Fig. 5.3 shows in its upper part a prototype potential energy as function of x , while in the lower part, with exactly the same x -scale, the corresponding phase portrait. From (5.2) we see that the phase portrait is symmetric with respect to the x -axis and that the phase curves must run from left to right in the upper half-plane and from right to left in the lower half-plane as time increases. The horizontal lines 1, 2, 3, and 4 in the upper graph label different energy levels E_0 of the oscillator for different types of motions. Since the kinetic energy is non-negative, the potential energy of a particular motion must lie below the corresponding energy level. The intersection points of any E_0 -line with the potential energy correspond to the intersection points of the phase curve with the x -axis. For levels 1, 2 the phase curves are closed orbits which look like ellipses intersecting the x -axis in two turning points at right angles. These closed orbits describe periodic vibrations of the point-mass about the equilibrium position C . The latter corresponds to the local minimum of the potential energy, so C is the stable center. For level 3 the phase curve is quite special. This curve passes through a saddle point S (corresponding to the local maximum of the potential energy), and consists of four branches, called separatrices² which do not intersect the x -axis at right angles. In our case the separatrices separate closed orbits from open phase curves like that of level 4, which describe aperiodic motions of the point-mass. The motion along any separatrix requires infinite amount of time to reach the unstable equilibrium position S . Such motions are called limit motions.

Using equation (5.2), we can now compute the time required to go from the initial point x_0 to point x along a fixed phase curve

² The given name originates from the fact that these branches separate regions filled with phase curves of different types.

$$t = t_0 \pm \int_{x_0}^x \frac{d\xi}{\sqrt{\frac{2}{m}[E_0 - U(\xi)]}}.$$

Again, the plus or minus sign depends on whether we are in the upper half or lower half of the phase plane. Taking into account the symmetry with respect to the x -axis, we obtain the period of vibration along any closed orbit

$$T = 2 \int_{x_m}^{x_M} \frac{d\xi}{\sqrt{\frac{2}{m}[E_0 - U(\xi)]}}, \quad (5.3)$$

where x_m and x_M are the minimum and maximum of x corresponding to the turning points. We see that the period of vibration (and therefore the related frequency) in the nonlinear theory depends on the initial energy, or, in other words, on the amplitude of vibration, in contrast to the linear theory.

Variational-Asymptotic Method. If the action functional contains some small parameter in the nonlinear term, then it is possible to find the correction to the solution and to the frequency without computing complicated integral (5.3). Let us consider for instance Duffing's equation (5.1) which can be obtained as Lagrange's equation of the functional

$$I[x(t)] = \int_0^T \left(\frac{1}{2} \dot{x}^2 - \frac{1}{2} x^2 - \frac{1}{4} \varepsilon x^4 \right) dt,$$

with T being the period of vibration. We assume simply $\alpha = \varepsilon$ as a small parameter. We know that the extremal of this functional depends on ε . On the other hand, the results of the previous paragraph show that the period (and the related frequency $\omega = 2\pi/T$) of vibration depends on the amplitude, and thus, on ε too. We want to make ω enter the action functional explicitly by stretching the time $\tau = \omega t$ so that the functional now takes the form

$$I[x(\tau)] = \frac{1}{\omega} \int_0^{2\pi} \left(\frac{1}{2} \omega^2 x'^2 - \frac{1}{2} x^2 - \frac{1}{4} \varepsilon x^4 \right) d\tau,$$

with prime denoting the derivative with respect to τ . Since the constant factor $1/\omega$ does not influence the extremal, instead of the obtained functional we consider the following one

$$I[x(\tau)] = \int_0^{2\pi} \left(\frac{1}{2} \omega^2 x'^2 - \frac{1}{2} x^2 - \frac{1}{4} \varepsilon x^4 \right) d\tau. \quad (5.4)$$

We try to find the *periodic* extremal of this functional. As $x(\tau)$ is periodic with respect to τ with the period 2π , we call τ phase (or *angular* time). Since the functional contains a small parameter ε , we shall use the variational-asymptotic method to study this variational problem (see [8, 31]). At the first step we put simply $\varepsilon = 0$ to get from (5.4)

$$I_0[x(\tau)] = \int_0^{2\pi} \left(\frac{1}{2} \omega^2 x'^2 - \frac{1}{2} x^2 \right) d\tau.$$

As we know from the linear theory, the 2π -periodic extremal of this functional is

$$x_0(\tau) = a \cos \tau. \quad (5.5)$$

Here a is the amplitude of vibration, the frequency ω is equal to 1 as expected, and we have chosen the initial phase $\phi = 0$ which is possible because functional (5.4) does not depend explicitly on time.

At the second step we seek the periodic extremal and the corresponding frequency in the form

$$x(\tau) = x_0(\tau) + x_1(\tau), \quad \omega = 1 + \omega_1, \quad (5.6)$$

where $x_1(\tau)$ is smaller than $x_0(\tau)$ in the asymptotic sense and $\omega_1 \ll 1$. We may assume that $x_1(\tau)$ and ω_1 are of the order ε of smallness although this is even not necessary. The order of smallness of $x_1(\tau)$ and ω_1 will automatically be determined in this step. Substituting (5.6) into (5.4) and keeping the asymptotically principal terms containing x_1 and the principal cross terms between x_0 and x_1 , we obtain³

$$I_1[x_1(\tau)] = \int_0^{2\pi} \left(\frac{1}{2}x_1'^2 + \underline{x_0'x_1'} + 2\omega_1 \underline{x_0'x_1'} - \frac{1}{2}x_1^2 - \underline{x_0x_1} - \varepsilon x_0^3 x_1 \right) d\tau.$$

Integrating the second and the third terms by parts taking into account the periodicity of $x_1(\tau)$, we see that the underlined terms are canceled out. Besides, the cubic of $x_0 = a \cos \tau$ can be transformed into the sum of harmonic cosine functions like that

$$x_0^3 = a^3 \cos^3 \tau = a^3 \left(\frac{3}{4} \cos \tau + \frac{1}{4} \cos 3\tau \right).$$

Finally we have

$$I_1[x_1(\tau)] = \int_0^{2\pi} \left(\frac{1}{2}x_1'^2 - \frac{1}{2}x_1^2 + \underline{(2\omega_1 a - \varepsilon \frac{3}{4}a^3) \cos \tau x_1} - \frac{1}{4} \varepsilon a^3 \cos 3\tau x_1 \right) d\tau.$$

This functional is reminiscent of that of forced linear oscillator, where the two last terms play the role of the work done by the external forces. The underlined term would lead then to resonance causing non-periodic x_1 with the amplitude tending to infinity as $\tau \rightarrow \infty$. However, it is obvious that such resonance cannot appear! Thus, for the consistency of our asymptotic expansion we require the coefficient of $\cos \tau$ in the functional I_1 to vanish.⁴ This consistency condition implies

$$2\omega_1 a - \varepsilon \frac{3}{4}a^3 = 0, \quad \text{that is,} \quad \omega_1 = \varepsilon \frac{3}{8}a^2. \quad (5.7)$$

Substituting the result into (5.6)₂, we get the correction for the frequency-amplitude relation

$$\omega = 1 + \varepsilon \frac{3}{8}a^2 + O(\varepsilon^2). \quad (5.8)$$

³ The terms containing only x_0 are dropped because x_0 is not subject to variation at this step.

⁴ Allowing some strong expression, we would say that the resonant or secular terms must be "killed".

The period $T = 2\pi/\omega$ may then be written as

$$T = \frac{2\pi}{1 + \varepsilon \frac{3}{8} a^2 + O(\varepsilon^2)} = 2\pi \left[1 - \varepsilon \frac{3}{8} a^2 + O(\varepsilon^2) \right]. \tag{5.9}$$

With the underlined resonant term being “killed” we find the extremal of functional I_1

$$x_1(\tau) = \varepsilon \frac{a^3}{32} (\cos 3\tau - \cos \tau). \tag{5.10}$$

Here we have chosen the initial condition such that $x(0) = a$ which is consistent with our choice $\phi = 0$.

Then at the next step we seek the corrections to the extremal and the frequency in the form

$$x(\tau) = x_0(\tau) + x_1(\tau) + x_2(\tau), \quad \omega = 1 + \omega_1 + \omega_2,$$

where $x_2(\tau)$ and ω_2 are smaller than $x_1(\tau)$ and ω_1 in the asymptotic sense, and repeat the same procedure as before (see exercise 5.2).

Notice that the similar procedure applied to the differential equations containing a small parameter has first been proposed by Lindstedt and Poincaré (see [32, 40]).

Comparison with the Exact Solution. It turns out that Duffing’s equation can be solved exactly in terms of Jacobian elliptic functions [3]. In this paragraph we want to get the frequency from this exact solution and compare it with the result obtained by the variational-asymptotic method.

First of all, let us collect some well known facts about Jacobian elliptic functions. There are three such functions: sn, cn, and dn. They depend on two variables, u and m , where u is called an argument and $m = k^2$ a modulus. In working with Jacobian elliptic functions the modulus m is often dropped, so we write $\text{sn}(u, m) = \text{sn}(u)$. Two of them, sn and cn, are quite similar to trigonometric sine and cosine. For example there are several identities resembling the well-known trigonometric formulas like

$$\begin{aligned} \text{sn}^2(u) + \text{cn}^2(u) &= 1, \\ \text{sn}'(u) &= \text{cn}(u)\text{dn}(u), \quad \text{cn}'(u) = -\text{sn}(u)\text{dn}(u), \end{aligned}$$

where prime denotes the derivative with respect to u . The elliptic function dn satisfies the equations

$$\text{dn}'(u) = -m\text{sn}(u)\text{cn}(u), \quad \text{and} \quad m\text{sn}^2(u) + \text{dn}^2(u) = 1.$$

The period of sn and cn in their argument u is $4K$ which is the complete elliptic integral of the first kind. The period of dn is $2K$. The asymptotic expansion of $K(m)$ is given by

$$K(m) = \frac{\pi}{2} \left[1 + \left(\frac{1}{2}\right)^2 m + \left(\frac{1.3}{2.4}\right)^2 m^2 + \dots \right]. \tag{5.11}$$

We look for the solution of Duffing's equation (5.1) in the form

$$x(t) = a \operatorname{cn}(u), \quad \text{where } u = bt + c, \tag{5.12}$$

and $a, b, c,$ and m are still unknown constants. Only two of them may be determined from the initial conditions. Let us fix the initial phase $c = 0$. Thus, there must be two relations for the remaining constants. To find these relations we compute the time derivative of $x(t)$

$$\dot{x} = ab \operatorname{cn}'(u) = -ab \operatorname{sn}(u) \operatorname{dn}(u).$$

Differentiating once again to get

$$\ddot{x} = -ab^2 [\operatorname{cn}(u) \operatorname{dn}^2(u) - m \operatorname{sn}^2(u) \operatorname{cn}(u)].$$

Using the above identities, this becomes

$$\ddot{x} = -ab^2 \operatorname{cn}(u) [1 - 2m + 2m \operatorname{cn}^2(u)].$$

Substituting the last equation into Duffing's equation (5.1) (where $\alpha = \varepsilon$) and equating to zero the coefficients of cn and cn^3 gives two equations relating $a, b,$ and m

$$\begin{aligned} a(2b^2m - b^2 + 1) &= 0, \\ -a(2b^2m - \varepsilon a^2) &= 0. \end{aligned}$$

Solving for b and m in terms of a , we obtain finally

$$b^2 = 1 + \varepsilon a^2, \quad m = \frac{\varepsilon a^2}{2(1 + \varepsilon a^2)}. \tag{5.13}$$

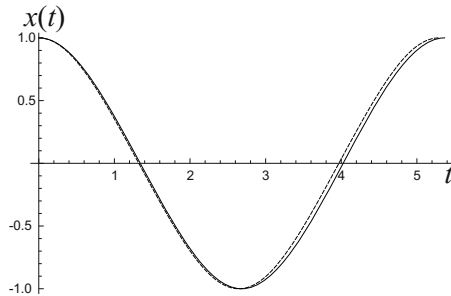

Fig. 5.4 Solution of Duffing's equation for $\varepsilon = 0.5$: i) Bold line: exact solution, ii) Dashed line: approximate solution

Formulas (5.12) and (5.13) give the exact solution of Duffing's equation. Its amplitude a corresponds to the amplitude of the approximate solution (5.5) and (5.10). The period T of the exact solution is $4K/b$ which may be written, using asymptotic formula (5.11),

$$T = \frac{4K(m)}{b} = \frac{2\pi}{b} \left[1 + \frac{1}{4}m + \frac{9}{64}m^2 + O(m^3) \right].$$

Substituting (5.13) into this equation and expanding for small ε , we obtain

$$T = 2\pi \left[1 - \varepsilon \frac{3}{8}a^2 + O(\varepsilon^2) \right]$$

which agrees with formula (5.9). Fig. 5.4 shows the comparison between the exact solution and the approximate one found in the previous paragraph for $\varepsilon = 0.5$. One can find for example in [6,20] the rigorous mathematical proof of convergence of the approximate solution to the exact one as $\varepsilon \rightarrow 0$ in any *finite* time interval. However, it is intuitively clear that for any small but finite ε the errors in period and in solution accumulate with the time and become of the order 1 for the time greater than T/ε .

5.2 Dissipative Oscillator

Differential Equation of Motion. For dissipative oscillators there are three types of nonlinearity: i) Non-quadratic energy and quadratic dissipation, ii) Quadratic energy and non-quadratic dissipation, iii) Both energy and dissipation are non-quadratic. The common feature of all dissipative oscillators is the positive definiteness of the dissipation causing the decrease of the energy. Therefore periodic motions in autonomous dissipative systems are clearly impossible. We consider three examples.

EXAMPLE 5.4. Mathematical pendulum with viscous damping. Derive the equation of motion of the mathematical pendulum considered in example 1.2 taking into account the air resistance through viscous damping.

As before the Lagrange function is given by

$$L(\varphi, \dot{\varphi}) = \frac{1}{2}ml^2\dot{\varphi}^2 - mgl(1 - \cos\varphi).$$

For the viscous damping we may assume that the dissipation function is quadratic with respect to the velocity $v = l\dot{\varphi}$

$$D = \frac{1}{2}c(l\dot{\varphi})^2.$$

Thus, generalized Lagrange's equation (2.31) yields

$$\ddot{\varphi} + \omega_0^2 \sin \varphi + \frac{c}{m}\dot{\varphi} = 0. \tag{5.14}$$

This pendulum belongs to the first type of dissipative oscillator with the nonlinear restoring force and the linear damping force.

EXAMPLE 5.5. Mass-spring oscillator with Coulomb’s friction. A mass m moves on the rough solid foundation under the action of a linear spring (see Fig. 5.5). Derive the equation of motion for this oscillator.

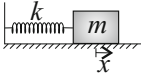

Fig. 5.5 Dry friction

Up to now we have analyzed dissipative oscillators with quadratic dissipation leading to the velocity proportional damping force. However, we are often confronted in reality with another type of damping, namely with the friction between solids with rough and unlubricated surfaces, called Coulomb’s (or “dry”) friction. The most important features of Coulomb’s friction are the existence of a threshold value f_0 for the zero velocity and the constant friction force for nonzero velocities. The force-velocity diagram for

Coulomb’s friction is shown schematically in Fig. 5.6. We see that this “constant” friction force is constant in magnitude but not in direction since its direction is always opposite to the direction of velocity.

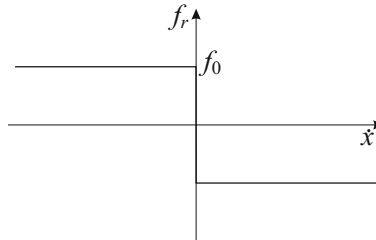

Fig. 5.6 Coulomb’s friction force

Looking at the force-velocity diagram we find that Coulomb’s friction force can be described by the equation

$$f_r(\dot{x}) = \begin{cases} f_0 & \text{for } \dot{x} < 0, \\ -f_0 & \text{for } \dot{x} > 0. \end{cases}$$

For $\dot{x} = 0$ the friction force may take an arbitrary value in between. Since $f_r = -dD/d\dot{x}$, we have

$$D(\dot{x}) = f_0|\dot{x}|. \tag{5.15}$$

Thus, the dissipation function $D(\dot{x})$ of Coulomb’s friction is a positive definite homogeneous function of the first order. Its graph is shown schematically in Fig. 5.7. Mention that $D(\dot{x})$ is non-smooth at $\dot{x} = 0$, but we can still use the constitutive equation $f_r = -dD/d\dot{x}$ for $\dot{x} = 0$ if $dD/d\dot{x}$ is understood in the sense of sub-differential. In this case f_r can take any value between $-f_0$ and f_0 .

Now, the equation of motion of this oscillator reads

$$m\ddot{x} = -kx + f_r(\dot{x}). \tag{5.16}$$

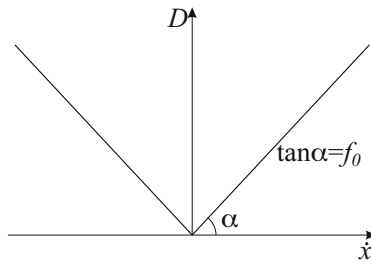

Fig. 5.7 Dissipation function of Coulomb’s friction

As the consequence, we see that as long as the magnitude of spring force $|kx|$ is less than f_0 , the mass, being released with the zero velocity, cannot move: it is “sticked” to the surface. So we have the “sticky” zone $-f_0/k \leq x \leq f_0/k$ in which all positions of the oscillator are the equilibrium positions. Released motions are possible only outside of this “sticky” zone. This is the example of oscillators of the second type.

EXAMPLE 5.6. Nonlinear oscillator with a quadratic damping.

If a small mass connected with a non-linear spring moves very fast in a gas or a fluid with a small viscosity, vorticities may occur around it. The resistance from these vorticities on the moving body may sometimes be approximated as proportional to the square of velocity of the point-mass. Such kind of damping is called a “turbulent” damping. Since the damping force acts in the opposite direction to the direction of motion, it must be equal to $f_r = -c|\dot{x}|\dot{x}$. The corresponding dissipation function is

$$D(\dot{x}) = \frac{1}{3}c|\dot{x}|^3.$$

Now the equation of motion reads

$$m\ddot{x} + c|\dot{x}|\dot{x} - f(x) = 0, \quad f(x) = -\frac{dU}{dx}. \tag{5.17}$$

As the spring force $f(x)$ is also non-linear, this oscillator belongs to the third type.

Phase Portrait. Since the energy decreases with time, it is for sure that the amplitude of vibration decays also. There are different methods to determine the evolution to equilibrium for dissipative systems with one degree of freedom. The most general and at the same time most descriptive method remains still that of phase portrait [4]. For all types of dissipative oscillators we may combine the restoring and damping forces in one and present the equation of motion in the form

$$\ddot{x} = f(x, \dot{x}),$$

where $f(x, \dot{x})$ is the resultant force (divided by m) acting on the point-mass. With $y = \dot{x}$ we may reduce this differential equation of second order to the system of equations of first order

$$\begin{aligned} \dot{x} &= y, \\ \dot{y} &= f(x,y). \end{aligned} \tag{5.18}$$

Thus, at each point (x,y) of the phase plane there is one vector $(y, f(x,y))$ tangent to the phase curve. One can plot this vector field and construct the phase curves by integrating numerically equations (5.18) using for example Euler's or Runge-Kutta's algorithm.

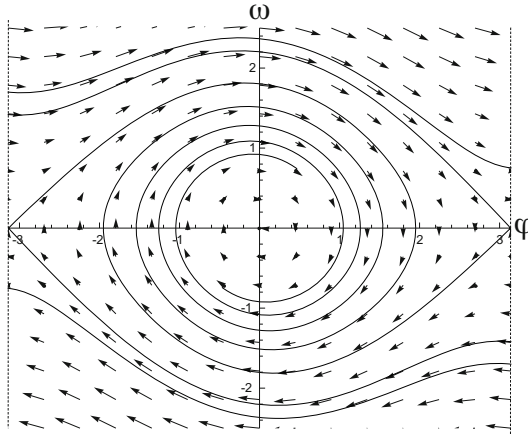

Fig. 5.8 Phase portrait of damped pendulum

Consider for instance the pendulum with viscous damping in example 5.4. The equation of motion (5.14) can be written in the dimensionless form as follows

$$\varphi'' + 2\delta\varphi' + \sin\varphi = 0,$$

where prime denotes the derivative with respect to $\tau = \omega_0 t$, and $\delta = \frac{c}{2m\omega_0}$ is Lehr's damping ratio. Reducing this equation to

$$\begin{aligned} \varphi' &= \omega, \\ \omega' &= -\sin\varphi - 2\delta\omega, \end{aligned}$$

we show the plot of the vector field $(\omega, -\sin\varphi - 2\delta\omega)$ and the phase curves in the phase plane in Fig. 5.8. By wrapping the phase plane onto the cylinder along the lines $\varphi = \pm\pi$ we obtain the phase portrait of the damped pendulum on the cylinder. We see that there are no periodic motions and that almost all phase curves tend to the stable equilibrium position $\varphi = 0$.

Oscillator with Coulomb Friction. For this type of oscillator the solution can directly be found from the energy balance equation. Let us first mention that the energy balance equation (2.32) derived in Section 2.4 should be modified for

Coulomb’s friction. Since the dissipation function (5.15) is homogeneous function of the first order, we have merely

$$\frac{dD}{d\dot{x}}\dot{x} = D(\dot{x}).$$

Thus, instead of (2.32) the energy balance equation for the Coulomb’s friction reads

$$K + U - E_0 = - \int_{t_0}^t D(\dot{x}(s))ds,$$

so that the factor 2 disappears here. With $D(\dot{x})$ from (5.15) we obtain

$$\frac{1}{2}m\dot{x}^2 + \frac{1}{2}kx^2 = E_0 - f_0|x - x_0|, \tag{5.19}$$

as long as x_0 is found outside of the “sticky” zone, where E_0 is the initial energy at point x_0 . It is interesting to note that the dissipation is rate-independent: it depends only on the initial and end coordinates of the point-mass.

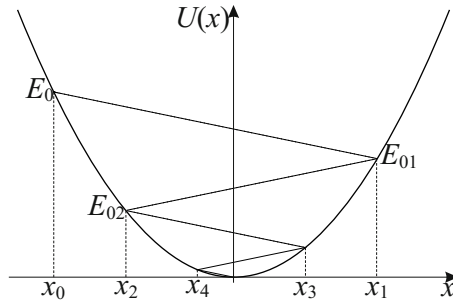

Fig. 5.9 Total energy and turning points of oscillator with Coulomb’s friction

Energy balance equation (5.19) gives a clear geometric method for determining the amplitude decay and the turning points of this oscillator. Fig. 5.9 shows the potential energy of the oscillator as well as the total energy during the process of motion. Assume that the point-mass is released from x_0 with the zero initial velocity and then moves to the right. According to (5.19) the total energy at x is $E_0 - f_0(x - x_0)$ since $x > x_0$. This is the straight line with the negative slope $-f_0$ describing the decay rate of the energy. The kinetic energy is the height between the total energy and the potential energy. It becomes zero at the turning point x_1 which is the intersection point between the parabola $U(x)$ and the straight line. Using this point x_1 and the corresponding energy E_{01} as the initial data, we find that the total energy of the motion thereafter must be $E_{01} + f_0(x - x_1)$, since the point mass moves now to the left with $x < x_1$. This is the straight line with the positive slope f_0 which intersects the parabola at the turning point x_2 . We can then repeat this geometric construction until $|x_n| < f_0/k$ where the point mass will be stucked there.

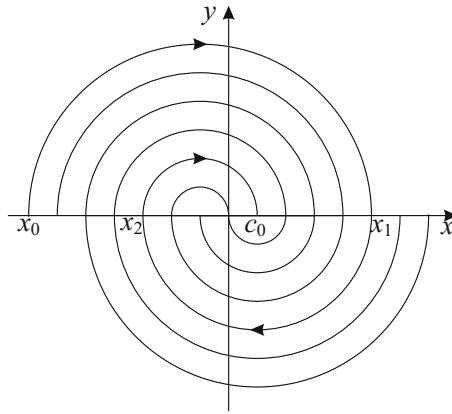

Fig. 5.10 Phase portrait of oscillator with Coulomb's friction

We can also use the energy balance equation (5.19) to plot the phase curves. Indeed, for $\dot{x} > 0$ we have

$$\frac{1}{2}m\dot{x}^2 + \frac{1}{2}kx^2 = E_0 - f_0(x - x_0).$$

Bringing term $-f_0x$ to the left-hand side and forming there the square of $x + c_0$ (with $c_0 = f_0/k$), we obtain

$$\frac{1}{2}m\dot{x}^2 + \frac{1}{2}k(x + c_0)^2 = E_0 + f_0x_0 + \frac{f_0^2}{2k},$$

or with $y = \dot{x}/\omega_0$ (where $\omega_0^2 = k/m$)

$$y^2 + (x + c_0)^2 = r^2, \quad r^2 = \frac{2}{k}(E_0 + f_0x_0 + \frac{f_0^2}{2k}).$$

We see that the phase curves in the upper half of the phase plane are half-circles with the center at point $-c_0$ on the x -axis. In the lower half-plane they are also half-circles but with the center at point c_0 on the x -axis. The sticky zone lies between these centers. As long as the phase curve does not hit the sticky zone, its continuation in the other half-plane is possible. The sticky zone is the “dead” zone for the phase curves (see Fig. 5.10).

Oscillator with “Turbulent” Damping. The equation of motion for the oscillator considered in example 5.6 can be integrated separately for $\dot{x} > 0$ and $\dot{x} < 0$. Indeed, consider first the case $\dot{x} > 0$ and denote $\dot{x} = v$. Since

$$\ddot{x} = \frac{dv}{dt} = \frac{dv}{dx} \frac{dx}{dt} = v \frac{dv}{dx} = \frac{1}{2} \frac{dv^2}{dx},$$

we can rewrite equation (5.17) in the form

$$\frac{dv^2}{dx} + \alpha v^2 - \frac{2}{m}f(x) = 0,$$

where $\alpha = 2c/m$. This inhomogeneous differential equation of first order can be integrated by the standard method of variation of coefficients [11] yielding

$$v^2(x) = e^{-\alpha x} \left(C_1 + \frac{2}{m} \int_0^x f(\xi) e^{\alpha \xi} d\xi \right).$$

Similarly, for $\dot{x} < 0$ we have

$$v^2(x) = e^{\alpha x} \left(C_2 + \frac{2}{m} \int_0^x f(\xi) e^{-\alpha \xi} d\xi \right).$$

The constants C_1 and C_2 are determined from the initial conditions. Let

$$\begin{aligned} U_+(x) &= -\frac{2}{m} \int_0^x f(\xi) e^{\alpha \xi} d\xi = \frac{2}{m} \int_0^x U'(\xi) e^{\alpha \xi} d\xi, \\ U_-(x) &= -\frac{2}{m} \int_0^x f(\xi) e^{-\alpha \xi} d\xi = \frac{2}{m} \int_0^x U'(\xi) e^{-\alpha \xi} d\xi. \end{aligned}$$

Assume that the point-mass is released from x_0 with the zero velocity $v_0 = 0$ and that it moves afterward in the positive direction. Then $C_1 = U_+(x_0)$ and

$$v^2(x) = e^{-\alpha x} [U_+(x_0) - U_+(x)], \quad \text{for } \dot{x} > 0.$$

The first turning point x_1 can then be found as the root of the equation $U_+(x_1) = U_+(x_0)$. Choosing now x_1 as the initial coordinate from which the point-mass is released and moves in the negative direction, we find that $C_2 = U_-(x_1)$ and that

$$v^2(x) = e^{\alpha x} [U_-(x_1) - U_-(x)], \quad \text{for } \dot{x} < 0.$$

Therefore, the second turning point, x_2 , must be the root of the equation $U_-(x_2) = U_-(x_1)$. Then we can choose x_2 as the initial coordinate from which the point-mass is released and repeat the procedure. So, if functions $U_+(x)$ and $U_-(x)$ are known, then the solution and the turning points can successively be determined.

For illustration let us consider the case of the quadratic potential energy (linear spring) with $U(x) = \frac{1}{2}kx^2$. In this case functions $U_+(x)$ and $U_-(x)$ can easily be computed

$$\begin{aligned} U_+(x) &= \frac{2}{m} \int_0^x k\xi e^{\alpha \xi} d\xi = -\frac{2k}{m\alpha^2} [e^{\alpha x}(1 - \alpha x) - 1], \\ U_-(x) &= \frac{2}{m} \int_0^x k\xi e^{-\alpha \xi} d\xi = -\frac{2k}{m\alpha^2} [e^{-\alpha x}(1 + \alpha x) - 1]. \end{aligned}$$

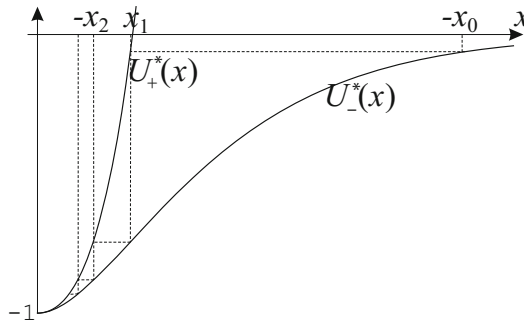

Fig. 5.11 Functions $U_+^*(x)$ and $U_-^*(x)$ and sequence of turning points

The constant factor $\frac{2k}{m\alpha^2}$ and the subtrahend -1 in the square brackets do not obviously influence the determination of the turning points. So, instead of $U_+(x)$ and $U_-(x)$ we can take the following functions

$$U_+^*(x) = -e^{\alpha x}(1 - \alpha x) \quad \text{and} \quad U_-^*(x) = -e^{-\alpha x}(1 + \alpha x)$$

for this purpose. Besides, $U_+^*(x) = U_-^*(-x)$, so it is enough to plot them for $x > 0$. Fig. 5.11 shows the plot of these functions and the geometric method of determining the sequence of turning points. As function $U_+^*(x)$ cuts the x -axis at point $1/\alpha$, whatever we take for the initial coordinate x_0 , the amplitude x_1 is always less than $1/\alpha$.

5.3 Self-excited Oscillator

This Section analyzes self-excited oscillators with one degree of freedom having sustained vibrations. The key features of such oscillators are the presence of an energy source and of a switcher, which switches the energy supply regime to the energy dissipation regime when the amplitude (or velocity) of vibrations becomes large.

Differential Equations of Motion. It was shown in the previous Section that free vibrations of any dissipative system about an equilibrium position decay with time, and in the limit $t \rightarrow \infty$ the system approaches equilibrium. Since in reality there are always some sources of small energy dissipation (viscosity, friction, drag force etc.), one might think that permanent vibrations of autonomous mechanical systems are not possible at all. However, the opposite is the case: one can observe everywhere in nature and technique permanent vibrations of living organisms, machines, and constructions. Examples may range from the beating of our hearts to pendulum clocks or flutter of bridges and airplane wings. Let us consider here some simple cases.

EXAMPLE 5.7. Stick-slip oscillator. A mass m connected with a linear spring of stiffness k moves on the rough band of a treadmill that rolls with a constant velocity v_0 (see Fig. 5.12). Derive the equation of motion for this oscillator taking into account Coulomb’s friction between the mass and the rolling band. Plot the power of the friction force against the velocity of the mass.

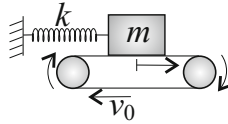

Fig. 5.12 Stick-slip oscillator

This example represents a primitive model of vibrations of a violin string. In terms of the displacement x and velocity \dot{x} the Lagrange function reads

$$L(x, \dot{x}) = \frac{1}{2}m\dot{x}^2 - \frac{1}{2}kx^2.$$

The dissipation function due to Coulomb’s friction between the rolling band and the mass must depend on their *relative* velocity $\dot{x} - v_0$, so

$$D(\dot{x}) = f_0|\dot{x} - v_0|.$$

Thus, generalized Lagrange’s equation is

$$m\ddot{x} + kx = f_r(\dot{x} - v_0),$$

where

$$f_r(\dot{x} - v_0) = \begin{cases} f_0 & \text{for } \dot{x} < v_0, \\ -f_0 & \text{for } \dot{x} > v_0. \end{cases}$$

For $\dot{x} = v_0$ the friction force f_r must be equal to the spring force taken with minus sign.

The most interesting property of this oscillator is that the power of the friction force may have both plus and minus sign. Indeed, doing the same calculations as in Section 2.4 for dissipative systems we obtain the balance of energy in the form

$$\frac{d}{dt}(K + U) = -\frac{\partial D(\dot{x} - v_0)}{\partial \dot{x}}\dot{x}.$$

The expression on the right-hand side is the power of the friction force f_r . For the oscillator vibrating about the equilibrium position with $v_0 = 0$ we have shown previously that this is equal to $-D(\dot{x})$, and thus, the energy dissipation rate is positive. In our case, the power may have both signs as one can see in Fig. 5.13.

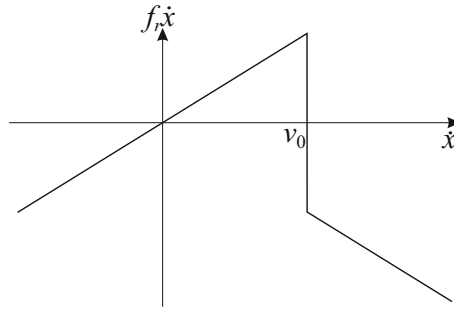

Fig. 5.13 Power of Coulomb's friction force

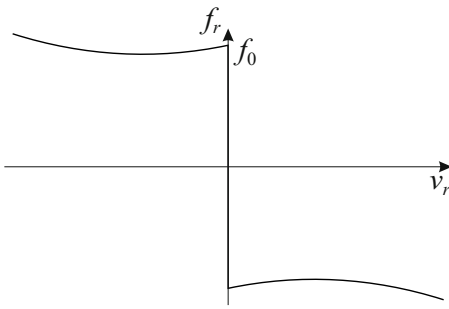

Fig. 5.14 Friction force f_r versus relative velocity $v_r = \dot{x} - v_0$

The positive power of the friction force means that energy is supplied to the oscillator amplifying the vibrations. In contrary, the negative power of the friction force (or, equivalently, the positive dissipation rate) means the energy loss which slows down the vibrations. We see that for our oscillator there is the possibility of amplifying the vibration in the region $0 < \dot{x} < v_0$. This does not still guarantee the self-excitation of small vibrations since we have also the energy loss for $\dot{x} < 0$ plus the air resistance through viscous damping which is always present. It should be

mentioned however that the more accurate experiments show a slight dependence of the friction force on the relative velocity as sketched in Fig. 5.14. This, as well as the air resistance through viscous damping in the system may have some influence on the stability of the equilibrium state. We will show later that, under some favorable conditions, the oscillator may develop self-sustained vibrations. From Fig. 5.13 we see also that the two different regimes of energy supply and energy dissipation is switched at the velocities $\dot{x} = 0$ and $\dot{x} = v_0$. Thus, in this case the switcher is velocity sensitive.

EXAMPLE 5.8. Froude's pendulum. A compound pendulum that is rigidly fasten to a sleeve in form of a ring mounted on a shaft rotating with a constant angular velocity v_0 (see Fig. 5.15). Derive the equation of motion of this pendulum taking into account the air resistance as well as Coulomb's friction between the rotating shaft and the sleeve. Plot the power of the friction moment against the angular velocity.

This example is quite similar to the previous one, except for non-quadratic potential energy. The Lagrange function of the pendulum is

$$L(\varphi, \dot{\varphi}) = \frac{1}{2}J\dot{\varphi}^2 - mgl(1 - \cos \varphi),$$

where J is the moment of inertia of the pendulum about the center O of the rotating shaft, and l the distance from the center of mass S to O . The dissipation function includes the dissipation due to the air resistance and the dissipation due to Coulomb's friction between the sleeve of the pendulum and the rotating shaft. The latter must be a function of the *relative* angular velocity. Thus,

$$D(\dot{\varphi}) = \frac{1}{2}cl^2\dot{\varphi}^2 + D_c(\dot{\varphi} - v_0),$$

and the generalized Lagrange's equation reads

$$J\ddot{\varphi} + mgl \sin \varphi + cl^2\dot{\varphi} - M_r(\dot{\varphi} - v_0) = 0.$$

Here $M_r(\dot{\varphi} - v_0)$ is the friction moment acting on the pendulum

$$M_r(\dot{\varphi} - v_0) = -\frac{\partial D_c(\dot{\varphi} - v_0)}{\partial \dot{\varphi}}.$$

If we take $D_c(\dot{\varphi} - v_0) = f_0r|\dot{\varphi} - v_0|$ as in the previous case, with r being the radius of the shaft (which is equal to the inner radius of the sleeve), then the plot of the power of the friction moment, $M_r\dot{\varphi}$, is exactly the same as that of the stick-slip oscillator. There exists the energy supply regime for the angular velocity $\dot{\varphi} \in (0, v_0)$. This does not still guarantee the self-excitation of small vibrations since we have also the energy loss for $\dot{\varphi} < 0$ plus that due to the air resistance. However, for the more realistic response curve of friction moment versus relative angular velocity similar to that shown in Fig. 5.14, the Froude's pendulum may also develop self-sustained vibrations (see exercise 5.7).

EXAMPLE 5.9. van der Pol's and similar oscillators.

If the mass-spring oscillator is connected with some energy source through a switcher, which switches from the energy dissipation to the energy supply regime when a certain combination of amplitude and velocity is less than 1, then the dissipation function may be proposed for example in the form

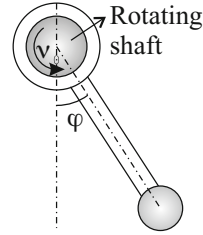

Fig. 5.15 Froude's pendulum

$$D(x, \dot{x}) = \frac{1}{2}c(\alpha x^2 + \frac{1}{2}\beta \dot{x}^2 - 1)\dot{x}^2,$$

where c , α , and β are positive constants. This formula does not contradict the second law of thermodynamics as the system under consideration is open and is connected with the energy source (or, equivalently, with an external force producing a positive power).⁵ Generalized Lagrange's equation takes the form

$$m\ddot{x} + kx + c(\alpha x^2 + \beta \dot{x}^2 - 1)\dot{x} = 0.$$

If $\beta = 0$, the oscillator is called van der Pol's oscillator.⁶ In this case the switcher is amplitude sensitive. On the contrary, for the case $\alpha = 0$ corresponding to Rayleigh's equation, the switcher is velocity sensitive like that of the stick-slip oscillator. In the general case (both α and β are non-zero), the switcher is of the mixed type. Mention that Rayleigh's equation can be transformed to van der Pol's equation as well (see exercise 5.9).

In what follows we shall study mainly van der Pol's oscillator as the prototype of self-excited oscillators. It is therefore convenient to bring its governing equation to the dimensionless form. For this purpose let us introduce the dimensionless quantities $\bar{t} = \sqrt{k/m}t$ and $\bar{x} = \sqrt{\alpha}x$. In their terms van der Pol's equation can be written as follow

$$\ddot{x} + x + \mu(x^2 - 1)\dot{x} = 0, \quad (5.20)$$

where $\mu = c/\sqrt{km}$, and the bar is dropped for short. Introducing $y = \dot{x}$, we can rewrite van der Pol's equation as the system of first order differential equations

$$\begin{aligned} \dot{x} &= y, \\ \dot{y} &= -x + \mu(1 - x^2)y, \end{aligned} \quad (5.21)$$

which has one fixed point at $(x, y) = (0, 0)$.

Energy Household and the Existence of Limit Cycles. To recognize, whether van der Pol's oscillator has a limit cycle in the phase plane or not, all we need is Poincaré-Bendixson theorem proved in the theory of ordinary differential equations (see [11]). Roughly speaking, this theorem states that if there exists a phase curve C of the 2-D continuous dynamical system that is "confined" to stay in some compact ring-shape region R of the phase plane not containing any fixed point, then either C is a limit cycle, or it spirals toward a limit cycle as t goes to infinity (see Fig. 5.16).

⁵ Of course, the dissipation function in this model can no longer be interpreted as the pure dissipative potential leading to the energy loss only.

⁶ Historically, this equation was deduced by van der Pol in 1920 to describe the self-excited oscillations of an electrical circuit used in the first radios (see [50]). Later on, this type of equation has been widely used in other physical systems as well, i.e., in laser, plasma, or flutter of airplane wings.

The finding of this “trapping” region for van der Pol’s oscillator is based on the analysis of energy change as the angle in the phase plane changes on one period 2π . Indeed, let us write down the energy balance equation for van der Pol’s oscillator

$$\frac{1}{2} \frac{d}{dt} (\dot{x}^2 + x^2) = \mu(1 - x^2)\dot{x}^2. \quad (5.22)$$

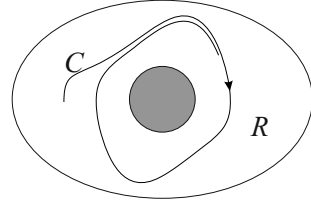

Fig. 5.16 “Trapping” region R

Consider some phase curve starting at point $(x, y) = (a_0, 0)$ in the phase plane. As the angle changes on 2π the phase curve cuts the x -axis again at another point $(a_1, 0)$. Integrating equation (5.22) over the time interval spent by the phase curve between these two points and taking into account that $y = \dot{x} = 0$ at the end-points, we obtain

$$\frac{1}{2} (a_1^2 - a_0^2) = \int_{t_0}^{t_1} \mu(1 - x^2)\dot{x}^2 dt = \Delta E. \quad (5.23)$$

The integral standing on the right-hand side is the energy change ΔE in one angular period 2π . Thus, if the energy is gained in one angular period ($\Delta E > 0$), then $|a_1| > |a_0|$. In contrary, if the energy is lost in one angular period ($\Delta E < 0$), then $|a_1| < |a_0|$.

Now, let μ be small. Then for the phase curve starting near the origin with small $a_0 > 0$ we expect that the solution remains small in one angular period. Then $|x(t)| \ll 1$ for $t \in (t_0, t_1)$ and the integrand on the right-hand side of (5.23) is positive. Thus, in one angular period we have the energy gain ($\Delta E > 0$), so $a_1 > a_0$ and the phase curve must be repelled from the origin. For the phase curve with a large initial amplitude $a_0 \gg 1$ the situation is more subtle. Since in one angular period the oscillator may dissipate energy as well as gain it when $x(t)$ comes close to zero, we must compute the energy change precisely. For $\mu = 0$ equation (5.20) is the equation of the harmonic oscillator having the solution $x(t) = a_0 \cos t$. It is natural to expect that for small μ the solution of (5.20) is close to $a_0 \cos t$ in one angular period. Since μ stands also in the integral (5.23), we may use this approximate solution to estimate the energy change in one angular period

$$\Delta E = \mu \int_0^{2\pi} (1 - a_0^2 \cos^2 t) a_0^2 \sin^2 t dt = -\mu \frac{\pi}{4} a_0^2 (a_0^2 - 4).$$

Thus, if $a_0 > 2$ then the energy change ΔE is negative, and the phase curve must be attracted to the origin. So, in the polar coordinates the ring-shape region trapping the phase curve is $r \in (\delta_1, \delta_2)$, with δ_1 a small positive number and $\delta_2 > 2$. We see also that the amplitude of a limit cycle must be close to 2 for small μ .

Up to now we do not know how many limit cycles van der Pol’s oscillator may have. This information can be obtained from Liénard’s theorem which is applied to all differential equations of the form

$$\ddot{x} + f(x)\dot{x} + g(x) = 0. \quad (5.24)$$

Equation (5.24) describes the motion of a unit mass subject to a nonlinear damping force $-f(x)\dot{x}$ and a nonlinear restoring force $-g(x)$. The formulation of Liénard's theorem is as follows: If

- $f(x)$ and $g(x)$ are continuously differentiable;
- $g(x)$ is an odd function and $g(x) > 0$ for $x > 0$;
- $f(x)$ is an even function;
- the odd function $F(x) = \int_0^x f(\xi) d\xi$ has exactly one positive zero at $x = b$, is negative for $0 < x < b$, is positive and nondecreasing for $x > b$, and $F(x) \rightarrow \infty$ as $x \rightarrow \infty$;

then equation (5.24) has one stable limit cycle surrounding the origin of the phase plane. Since this limit cycle attracts phase curves to it, it is called an attractor. Now, for van der Pol's oscillator we have

$$g(x) = x, \quad f(x) = \mu(x^2 - 1).$$

Integrating $f(x)$ we obtain $F(x) = \mu x(\frac{1}{3}x^2 - 1)$. Thus, all conditions required in Liénard's theorem are satisfied (for the last condition we have $b = \sqrt{3}$). Consequently, van der Pol's equation has only one stable limit cycle.

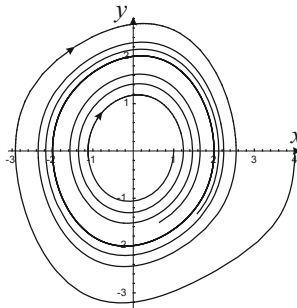

Fig. 5.17 Phase curves and limit cycle of van der Pol's equation with $\mu = 0.1$

Numerical Solutions. Now we know that all phase curves of van der Pol's oscillator are attracted to the limit cycle. But how do they approach this cycle and what does the limit cycle look like? These questions can only be answered by integrating equation (5.20), or equivalently, system (5.21). Unfortunately, analytical solutions are not available. So, let us try to integrate (5.21) numerically by using for instance *Mathematica*. We open a notebook in *Mathematica* and simply write the following commands

```
sol = NDSolve[{x'[t] == y[t], y'[t] == -x[t] + 0.1 (1 - x[t]^2) y[t],
  x[0] == 4, y[0] == 0}, {x, y}, {t, 30}]
ParametricPlot[Evaluate[{x[t], y[t]} /. sol], {t, 0, 30}]
```

In this case we took $\mu = 0.1$ and assumed the initial conditions $x(0) = 4, y(0) = 0$. The result of computations is shown in Fig. 5.17, and we see that the phase curve is really attracted to the limit cycle drawn by the thick line which is close in form to the circle of radius 2. If we take a starting point inside the cycle, the phase curve also spirals to the limit cycle from inside.

If we want to know how the solution changes in time, we add a command

```
Plot[Evaluate[x[t] /. sol], {t, 0, 30}]
```

and the computer gives us the curve $x(t)$ shown in Fig. 5.18. The behavior of this solution is quite similar to that of damped oscillator discussed in Section 1.2 except that the amplitude of vibration does not tend to zero but to some value close to 2. As one can observe, there are two characteristic time scales: i) one describing the period of fast oscillation of $x(t)$, ii) the other associated with the monotonic and slow change of amplitude of vibration toward that of the limit cycle shown by the envelopes.

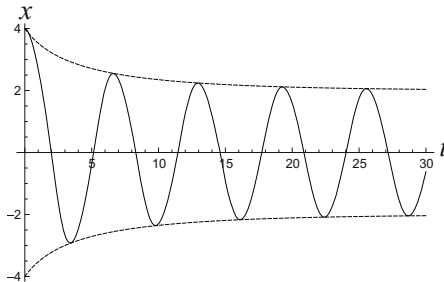

Fig. 5.18 Solution $x(t)$ of van der Pol's equation for $\mu = 0.1$: i) bold line: $x(t)$, ii) dashed lines: envelopes

If we enlarge the parameter μ , the limit cycle deviates more and more from the circle. The motion deviates also from the harmonic motion. For very large μ van der Pol's oscillator exhibits quite interesting type of vibrations called relaxation oscillations. The limit cycle and the corresponding plot of $x(t)$ for $\mu = 10$ are shown in Fig. 5.19. One can see a sequence of slow motions which are quickly switched to other slow motions. This phenomenon will be explained in the next Section.

Limit Cycle of Stick-Slip Oscillator. Poincaré-Bendixson's or Liénard's theorem cannot be applied to oscillators with Coulomb's friction because of the discontinuity of the friction force. So this type of oscillators requires always a special treatment. Let us analyze the stick-slip oscillator considered in example 5.7. Taking also the air resistance into account, we write down the equation of motion

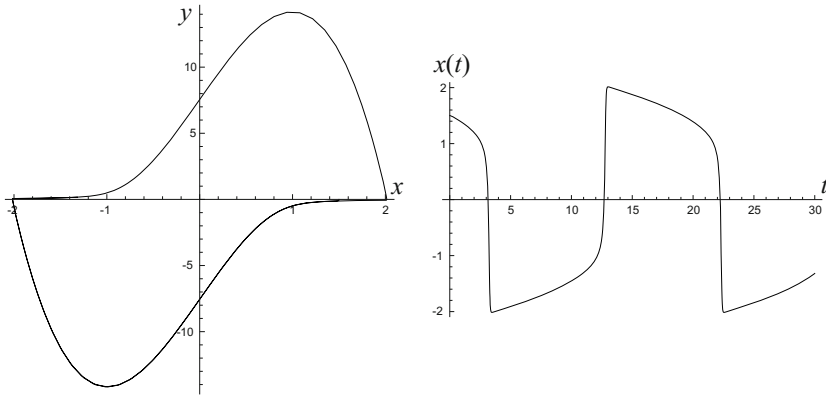

Fig. 5.19 Limit cycle (left) and solution $x(t)$ (right) of van der Pol's equation with $\mu = 10$

$$m\ddot{x} + c\dot{x} + kx = f_r(\dot{x} - v_0).$$

Dividing this equation by k and introducing the notation

$$\frac{k}{m} = \omega_0^2, \quad \frac{c}{2\sqrt{km}} = \delta, \quad \frac{v_0}{\omega_0} = v_0,$$

we rewrite it in the form (compare with (1.15))

$$x'' + 2\delta x' + x = r(x' - v_0),$$

where

$$r(x' - v_0) = \frac{f_r(\omega_0(x' - v_0))}{k},$$

and prime denotes the derivative with respect to $\tau = \omega_0 t$. This second order differential equation is equivalent to the system of equations

$$\begin{aligned} x' &= y, \\ y' &= r(y - v_0) - 2\delta y - x, \end{aligned} \tag{5.25}$$

which has one fixed point S on the x -axis with the coordinate $x_0 = r(-v_0)$. The slope of the phase curve at point (x, y) is equal to

$$\frac{dy}{dx} = \frac{r(y - v_0) - 2\delta y - x}{y}. \tag{5.26}$$

The first interesting thing to know is whether the fixed point S of this dynamical system is a stable equilibrium position or not. To do the stability analysis near the fixed point we seek the neighboring solution of (5.25) in the form

$$x = x_0 + u, \quad y = v,$$

where $u \ll 1$ and $v \ll 1$ and linearize the system (5.25) with respect to u and v . Since

$$r(v - v_0) = r(-v_0) + \left. \frac{dr}{dv} \right|_{-v_0} v + O(v^2),$$

we obtain

$$u' = v, \quad v' = \left(\left. \frac{dr}{dv} \right|_{-v_0} - 2\delta \right) v - u,$$

what is equivalent to the equation

$$u'' - \left(\left. \frac{dr}{dv} \right|_{-v_0} - 2\delta \right) u' + u = 0.$$

Thus, if

$$\left. \frac{dr}{dv} \right|_{-v_0} > 2\delta,$$

then the fixed point is an unstable focus, and the phase curves starting near this fixed point are repelled from it.

To be able to simulate the phase curves numerically let us assume that the dynamic friction force is described by a function $r(v)$ of the form

$$r(v) = \begin{cases} \frac{1}{2} + \frac{1}{2}(v + 1)^2 & \text{for } v < 0, \\ -\frac{1}{2} - \frac{1}{2}(v - 1)^2 & \text{for } v > 0. \end{cases}$$

The threshold friction force is $r_0 = 1$ in this case, and for $v = 0$ function $r(v)$ can take any value between $-r_0$ and r_0 . The constant velocity is $v_0 = 0.5$, while Lehr's damping ratio is chosen to be $\delta = 0.01$. It is easy to check that $r'(-0.5) = 0.5 > 2\delta$.

The vector field and some phase curves of this oscillator are plotted in Fig. 5.20. The phase curves hitting the horizontal line $y = v_0$ must change their slopes abruptly when crossing this line. By this reason the line $y = v_0$ is called a jump line. According to equation (5.26) the jump of the slopes must be equal to $-2r_0/v_0$. Besides, there is a "sticky" zone $-r_0 - 2\delta v_0 < x < r_0 - 2\delta v_0$ on this jump line (the segment AC), where the mass is stuck to the band and move together with it with the constant velocity v_0 . When the phase curves hit this sticky zone, they have to move along the horizontal line up to point C with coordinates $(r_0 - 2\delta v_0, v_0)$, where the mass is detached from the band and the slip begins. The phase curve starting from point

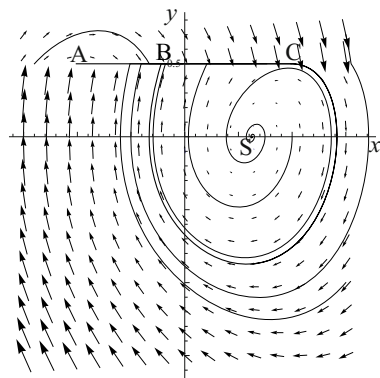

Fig. 5.20 Limit cycle of stick-slip oscillator

C is a spiral, which hit the segment AC at point B if the damping ratio δ is small. This phase curve together with the segment BC correspond to the limit cycle of the stick-slip oscillator. Indeed, the phase curves starting inside this cycle are repelled from S and will hit the jump line at some point between B and C and merge with the limit cycle afterwards. The phase curves starting outside of this cycle will sooner or later hit the segment AC and after a while merge with the limit cycle. The specific feature of the stick-slip oscillator is that the limit cycle is established after a finite time.

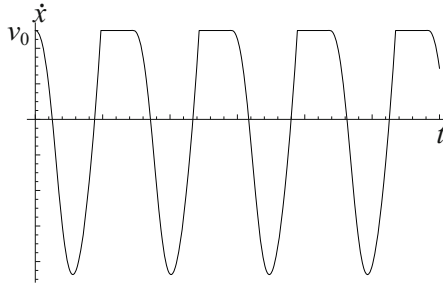

Fig. 5.21 Plot of $\dot{x}(t)$ at the limit cycle

It is interesting to plot the velocity \dot{x} at the limit cycle as function of time. This plot is shown in Fig. 5.21. We can see clearly the sequence of stick and slip regimes, where $\dot{x} = v_0$ in the stick regime.

5.4 Oscillator with Weak or Strong Dissipation

Mathematical Formulation. The results of previous two Sections show that the phase curves of dissipative systems may approach some attractor in the phase plane as time goes to infinity. If the energy dissipation rate is positive definite, then the attractor corresponds just to the equilibrium states. In contrary, if the energy dissipation rate is no longer positive definite, the attractor may become a limit cycle. In both cases the amplitude and phase of vibration change slowly with time. It turns out that if the dissipation function of the system is small in the sense that the governing equation is obtained from the following variational equation

$$\delta \int_{t_0}^{t_1} \left(\frac{1}{2} \dot{x}^2 - \frac{1}{2} x^2 \right) dt - \int_{t_0}^{t_1} \varepsilon \frac{\partial D}{\partial \dot{x}} \delta x dt = 0, \tag{5.27}$$

with $\varepsilon D(x, \dot{x})$ being the dissipation function and ε a small parameter, then the evolution of the system to the attractor can be determined analytically in the limit $\varepsilon \rightarrow 0$. It is easy to see that the governing equation of this system reads

$$\ddot{x} + x = \varepsilon f(x, \dot{x}),$$

where

$$f(x, \dot{x}) = -\frac{\partial D}{\partial \dot{x}}.$$

We need to find the asymptotic behavior of solution in the limit $\varepsilon \rightarrow 0$.

Variational-Asymptotic Method. We have seen from the numerical simulations of van der Pol’s oscillator in the previous Section that, if ε is not equal to zero, the amplitude of vibration will change slowly with time due to the energy dissipation. The same can happen also to the period T as well as to the related frequency ω as they are in general amplitude-dependent. Similar to the asymptotic analysis provided for Duffing’s equation in Section 5.1 we want to make ω enter the variational equation (5.27) explicitly. For this purpose we multiply (5.27) with ω and rewrite it in terms of the stretched angular time $\tau = \omega t$ for one fixed period 2π

$$\delta \int_{\tau_0}^{\tau_0+2\pi} \left(\frac{1}{2} \omega^2 x'^2 - \frac{1}{2} x^2 \right) d\tau + \int_{\tau_0}^{\tau_0+2\pi} \varepsilon f(x, \omega x') \delta x d\tau = 0, \tag{5.28}$$

where prime denotes the derivative with respect to the angular time τ , and τ_0 is an arbitrary time instant. For short we set $\tau_0 = 0$.

At the first step of the variational-asymptotic procedure we put simply $\varepsilon = 0$ to get from (5.28)

$$\delta \int_0^{2\pi} \left(\frac{1}{2} \omega^2 x'^2 - \frac{1}{2} x^2 \right) d\tau = 0.$$

This leads to the eigenvalue problem yielding the following 2π -periodic extremal

$$x_0(\tau) = a \cos \tau.$$

Here a is the amplitude of vibration, the frequency ω is equal to 1 as expected, and we have chosen the initial phase $\phi = 0$, which is possible because the governing equation does not depend explicitly on time.

Taking into account that the amplitude a and the frequency ω are becoming slightly dependent on time for $\varepsilon \neq 0$, we introduce the slow time $\eta = \varepsilon \tau$ and seek the corrections to the extremal and to the frequency at the second step in the form⁷

$$x(\tau) = a(\eta) \cos \tau + x_1(\tau, \eta), \quad \omega = 1 + \omega_1(\eta), \tag{5.29}$$

where $x_1(\tau, \eta)$ is a 2π -periodic function with respect to the fast time τ and is much smaller than $x_0(\tau, \eta)$ in the asymptotic sense, and $\omega_1(\eta)$ is much smaller than 1. To make the asymptotic analysis of small terms easier we may assume that x_1 and ω_1 are of the order ε although this is even not necessary. The order of smallness of x_1 and ω_1 will automatically be determined in this step. Since the angular time τ is present also in η , the time derivative of $x(\tau)$ becomes

$$x'(\tau) = -a(\tau) \sin \tau + \varepsilon a_{,\eta} \cos \tau + x_{1,\tau} + \varepsilon x_{1,\eta},$$

⁷ This is the crucial idea of two-timing or multi-scaling.

where the comma before an index denotes the partial derivative with respect to the corresponding variable. Let us substitute (5.29) into (5.28) and keep the asymptotically principal terms containing x_1 and the principal cross terms between x_0 and x_1 . Because the small parameter ε is already present in the last term of (5.28), it is accurate at this step to replace $f(x, \omega x')$ by $f(a \cos \tau, -a \sin \tau)$. Now the variational equation becomes

$$\delta \int_0^{2\pi} \left[\frac{1}{2} x_{1,\tau}^2 - \underline{a \sin \tau x_{1,\tau}} + \underline{\varepsilon a_{,\eta} \cos \tau x_{1,\tau}} - \underline{2\omega_1 a \sin \tau x_{1,\tau}} - \frac{1}{2} x_1^2 - a \cos \tau x_1 + \varepsilon f(a \cos \tau, -a \sin \tau) x_1 \right] d\tau = 0.$$

Integrating the underlined terms by parts using the periodicity of x_1 in τ we obtain finally

$$\delta \int_0^{2\pi} \left[\frac{1}{2} x_{1,\tau}^2 - \frac{1}{2} x_1^2 + 2(\varepsilon a_{,\eta} \sin \tau + \omega_1 a \cos \tau) x_1 + \varepsilon f(a \cos \tau, -a \sin \tau) x_1 \right] d\tau = 0. \quad (5.30)$$

Aside from the negligibly small change of amplitude a in one period we may regard function $f(a \cos \tau, -a \sin \tau)$ as 2π -periodic with respect to τ . Let us expand it in the Fourier series on the interval $(0, 2\pi)$

$$f(a \cos \tau, -a \sin \tau) = g_0(a) + \sum_{n=1}^{\infty} [g_n(a) \cos n\tau + h_n(a) \sin n\tau].$$

Substituting this expansion into equation (5.30) we see that there are two resonant terms in this functional, namely

$$\varepsilon [2a_{,\eta} + h_1(a)] \sin \tau x_1 \quad \text{and} \quad [2\omega_1 a + \varepsilon g_1(a)] \cos \tau x_1.$$

From the linear theory we know that such resonant (or secular) terms would lead to nonperiodic x_1 contradicting our asymptotic expansion. To be consistent, we have to remove them. These consistency conditions yield two equations for the amplitude $a(\eta)$ and for the correction of the frequency ω_1

$$\begin{aligned} a_{,\eta} &= -\frac{1}{2} h_1(a) = -\frac{1}{2\pi} \int_0^{2\pi} f(a \cos \tau, -a \sin \tau) \sin \tau d\tau, \\ \omega_1 &= -\frac{\varepsilon}{2a} g_1(a) = -\frac{\varepsilon}{2\pi a} \int_0^{2\pi} f(a \cos \tau, -a \sin \tau) \cos \tau d\tau. \end{aligned} \quad (5.31)$$

Since the change of $a(\eta)$ in one period is of the order ε , we may regard it as ‘‘frozen’’ in the integrals on the right-hand sides.

With the resonant terms being ‘‘killed’’ we can find in principle the extremal $x_1(\tau, \eta)$ in the above variational problem. It has to satisfy the following equation

$$x_{1,\tau\tau} + x_1 = \varepsilon \left\{ g_0(a) + \sum_{n=2}^{\infty} [g_n(a) \cos n\tau + h_n(a) \sin n\tau] \right\}.$$

Then at the next step we seek the corrections to the extremal and to the frequency in the form

$$x(\tau) = x_0(\tau, \eta) + x_1(\tau, \eta) + x_2(\tau, \eta), \quad \omega = 1 + \omega_1(\eta) + \omega_2(\eta),$$

where x_2 and ω_2 are much smaller than x_1 and ω_1 in the asymptotic sense, and repeat the same procedure as before.

Notice that the similar procedure applied to the differential equations containing a small parameter has first been proposed by Bogoliubov and Mitropolsky [9].

Applications. Since the developed variational-asymptotic method does not put any constraint on the dissipation function, we can apply it to both dissipative and self-excited oscillators.

We illustrate how the method works first on the simple example of the linear damped oscillator whose solution is given by formula (1.18). In this case $f(x, \dot{x}) = -\dot{x}$ and $\varepsilon = 2\delta$. Computing the integrals on the right-hand sides of (5.31) we obtain two equations

$$a_{,\eta} = -\frac{a}{2}, \quad \omega_1 = 0.$$

According to the second equation there is no correction to the frequency and the period of vibration within the first approximation. Concerning the amplitude of vibration we obtain the law of its change by integrating the first equation giving $a = a_0 e^{-\eta/2} = a_0 e^{-\delta\tau}$, with a_0 being the initial amplitude. Combining this formula for a with (5.29) we get in the first approximation

$$x(\tau) = a_0 e^{-\delta\tau} \cos \tau.$$

In comparison with the exact solution $x(\tau) = a_0 e^{-\delta\tau} \cos \nu\tau$ (which is obtained from (1.18) when $\phi = 0$), we see only a slight difference in the frequency of vibration: the exact conditional frequency $\nu = \sqrt{1 - \delta^2} \approx 1 + O(\varepsilon^2)$. The evolution of the amplitude coincides with that of the exact solution.

Next, let us apply the method to van der Pol's oscillator, for which no analytical solution is available. In this case $f(x, \dot{x}) = (1 - x^2)\dot{x}$ and $\varepsilon = \mu$. Similar calculations of integrals in (5.31) give

$$a_{,\eta} = \frac{a}{8}(4 - a^2), \quad \omega_1 = 0. \tag{5.32}$$

As in the previous example there is no correction to the frequency and the period of vibration. In contrast to the exact van der Pol equation, equation (5.32) for a can be integrated analytically. Indeed, multiplying this equation with a and noting that $aa_{,\eta} = \frac{1}{2}(a^2)_{,\eta}$ we transform it to the following equation

$$y_{,\eta} = \frac{1}{4}y(4 - y),$$

where $y = a^2$. The above equation can be integrated by separating the variables giving

$$\ln \frac{y}{4-y} = \eta + C.$$

The constant of integration can be obtained from the initial condition $y(0) = y_0$: $C = \ln \frac{y_0}{4-y_0}$. Substituting this constant in the last equation and solving it with respect to y we obtain

$$y = \frac{4y_0 e^\eta}{4 + y_0(e^\eta - 1)},$$

or, in terms of the original amplitude a and time τ

$$a = \frac{2a_0 e^{\varepsilon\tau/2}}{\sqrt{4 + a_0^2(e^{\varepsilon\tau} - 1)}}. \quad (5.33)$$

In order to compare with the numerical solution we plot $a(\tau)$ from (5.33) and show it together with $x(t)$ in Fig. 5.18 (the dashed envelope). The agreement is striking, although $\varepsilon = 0.1$ is not quite small. We can also check that a approaches 2 as $\tau \rightarrow \infty$.

Limit Cycle of Relaxation Oscillations. We have seen that for small μ the limit cycle of van der Pol's oscillator is nearly a circle of radius 2, and its frequency is nearly equal to 1. Consider now the opposite case of van der Pol's oscillator with a large parameter μ . As our numerical simulations have shown, the solution corresponding to the limit cycle spends most of time in a slow motion, and then quickly jumps to another slow motion. We analyze this motion by applying the variational-asymptotic method to the variational equation

$$\delta \int_{t_0}^{t_1} \left(\frac{1}{2} \dot{x}^2 - \frac{1}{2} x^2 \right) dt + \int_{t_0}^{t_1} \mu (1 - x^2) \dot{x} \delta x dt = 0. \quad (5.34)$$

Let us first concentrate on the slow motion. Introducing the slow time $\eta = t/\mu$, we have $\dot{x} = x_{,\eta}/\mu$, with $x_{,\eta}$ being the derivative with respect to η . Thus, equation (5.34), multiplied by μ , becomes

$$\delta \int_{\eta_0}^{\eta_1} \left(\frac{1}{2\mu^2} x_{,\eta}^2 - \frac{1}{2} x^2 \right) d\eta + \int_{\eta_0}^{\eta_1} (1 - x^2) x_{,\eta} \delta x d\eta = 0.$$

Neglecting the first term in this equation⁸ as small in accordance with the variational-asymptotic method, we arrive at the equation

$$-x + (1 - x^2)x_{,\eta} = 0, \quad \text{or} \quad x_{,\eta} = \frac{x}{1 - x^2}.$$

⁸ This means neglecting the kinetic energy as small compared with the potential energy and dissipation. Thus, the slow motion can be regarded as the motion without inertia.

This differential equation can be solved by separation of variables yielding

$$\ln|x| - \frac{x^2}{2} = \eta + \text{const.}$$

The slow motion proceeds according to this equation until it reaches $x = \pm 1$ where the speed $x_{,\eta}$ is infinite. At this point the assumption of slow motion is violated, so we need to change to another time scale. Introducing now the fast time $\tau = \mu t$, $\dot{x} = \mu x_{,\tau}$, we rewrite (5.34), divided by μ , in the form

$$\delta \int_{\tau_0}^{\tau_1} \left(\frac{1}{2} \mu^2 x_{,\tau}^2 - \frac{1}{2} x^2 \right) d\tau + \int_{\tau_0}^{\tau_1} \mu^2 (1 - x^2) x_{,\tau} \delta x d\tau = 0.$$

Neglecting the second term as small compared with other terms, we arrive at the differential equation

$$x_{,\tau\tau} - (1 - x^2)x_{,\tau} = 0.$$

This equation possesses the first integral

$$x_{,\tau} - x + x^3/3 = \text{const},$$

representing the fast motion (jump). We choose the constant of integration so that this fast motion starting at $x = 1$ as an equilibrium point (with $x_{,\tau} = 0$) will end at another equilibrium point with $x_{,\tau} = 0$. It is easy to see that the constant is equal to $-2/3$ giving the second equilibrium point at $x = -2$. Similarly, the jump starting at $x = -1$ ends up at $x = 2$.

Knowing the solution, we can now easily compute the period of this relaxation oscillation. Since the time spent for jumps is negligible compared to the time spent at slow motions, we compute just the half-period of slow motion as

$$T/2 = \mu \left(\ln|x| - x^2/2 \right) \Big|_{x=2}^{x=-1} = \mu \left(\frac{3}{2} - \ln 2 \right).$$

Thus, the period $T = \mu(3 - 2 \ln 2)$ tends to infinity as $\mu \rightarrow \infty$.

5.5 Exercises

EXERCISE 5.1. A point-mass m moves under the action of gravity along a frictionless circular wire of radius r that is rotating with a constant angular velocity Ω about its vertical diameter (see Fig. 5.22).⁹ Derive the equation of motion and plot the potential energy as well as the phase portrait.

Solution. Since the point-mass moves along the wire that rotates about the vertical axis, its absolute velocity equals

$$\mathbf{v} = \mathbf{v}_l + \mathbf{v}_r.$$

⁹ A pendulum oscillating on a rotating platform can serve as a similar example.

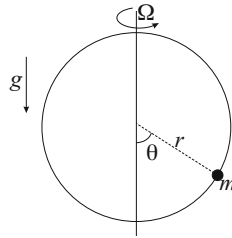

Fig. 5.22 Point-mass on rotating circular wire

In this formula \mathbf{v}_l is the instantaneous velocity of the point-mass moving together with the rotating frame as rigid body, while \mathbf{v}_r is its velocity relative to the rotating frame. As these two vectors are orthogonal to each other and their magnitudes are $\Omega r \sin \theta$ and $r\dot{\theta}$, respectively, the kinetic energy of the point-mass reads

$$K = \frac{1}{2}mv^2 = \frac{1}{2}mr^2(\dot{\theta}^2 + \Omega^2 \sin^2 \theta).$$

Choosing the zero level of potential energy at the horizontal plane $\theta = \pi/2$, the potential energy of the point-mass in the gravitation field is given by

$$U = -mgr \cos \theta.$$

Thus, the Lagrange function equals

$$L = K - U = \frac{1}{2}mr^2\dot{\theta}^2 + \frac{1}{2}mr^2\Omega^2 \sin^2 \theta + mgr \cos \theta.$$

We may interpret the first term of L as the kinetic energy of the motion relative to the rotating frame, while the term $-\frac{1}{2}mr^2\Omega^2 \sin^2 \theta$ as the potential energy of the fictitious “centrifugal force”, called centrifugal energy. From Lagrange’s equation we derive the equation of motion

$$mr^2\ddot{\theta} - mr^2\Omega^2 \sin \theta \cos \theta + mgr \sin \theta = 0.$$

The above equation of motion can be transformed to the dimensionless form

$$\theta'' - \omega^2 \sin \theta \cos \theta + \sin \theta = 0,$$

where $\omega = \Omega/\omega_0 = \Omega/\sqrt{g/r}$ and where prime denotes the derivative with respect to the dimensionless time $\tau = \omega_0 t$. This equation yields the conservation law

$$\frac{1}{2}\theta'^2 - \cos \theta + \frac{1}{4}\omega^2 \cos 2\theta = E_0.$$

The plots of the modified potential energy $\tilde{U}(\theta) = -\cos \theta + \frac{1}{4}\omega^2 \cos 2\theta$ for different ω are shown in Fig. 5.23, where the points $\theta = -\pi$ and $\theta = \pi$, due to the

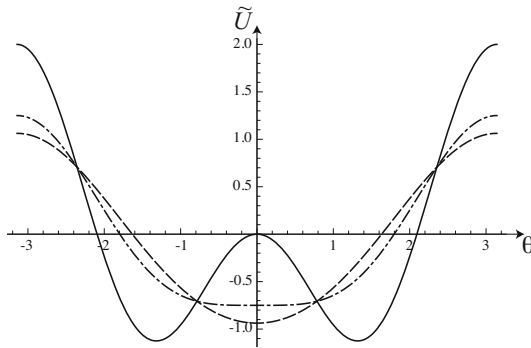

Fig. 5.23 Modified potential energy $\tilde{U}(\theta)$: i) $\omega = 0.5$ (dashed line), ii) $\omega = 1$ (dashed and dotted line), iii) $\omega = 2$ (bold line)

periodicity in θ , have to be identified. For $\omega < 1$ the modified potential energy has one local minimum at $\theta = 0$ corresponding to the stable equilibrium state and one local maximum at $\theta = \pm\pi$ corresponding to the unstable equilibrium state (saddle point). For $\omega > 1$ there are two local minima at $\theta = \pm\theta_0 = \pm \arccos(1/\omega)$, and two local maxima at $\theta = 0$ and at $\theta = \pm\pi$. The saddle-node bifurcation occurs at $\omega = 1$. The phase portrait of this rotating pendulum is plotted in Fig. 5.24 for $\omega = 2$. We see that there are two stable centers corresponding to two minima and two saddle points corresponding to the maxima of the potential energy.

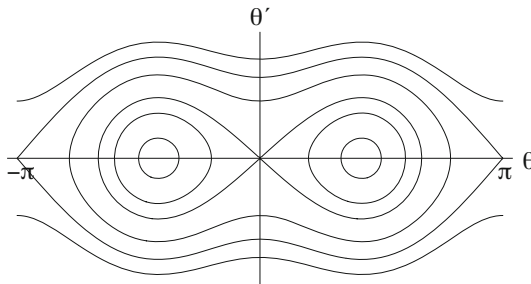

Fig. 5.24 Phase portrait of the rotating pendulum ($\omega = 2$)

EXERCISE 5.2. Do the next step of the variational-asymptotic procedure for Duffing’s equation and show that

$$T = 2\pi \left[1 - \varepsilon \frac{3}{8} a^2 + \varepsilon^2 \frac{57}{256} a^4 + O(\varepsilon^3) \right].$$

Solution. At the third step we substitute

$$x(\tau) = x_0(\tau) + x_1(\tau) + x_2(\tau), \quad \omega = 1 + \omega_1 + \omega_2$$

into the action functional (5.4). Keeping the asymptotically principal terms containing x_2 and the principal cross terms between x_0 , x_1 , and x_2 , we obtain

$$I_2[x_2(\tau)] = \int_0^{2\pi} \left[\frac{1}{2}x_2'^2 + \underline{x_0'x_2'} + \underline{2\omega_1x_0'x_2'} + \underline{(2\omega_2 + \omega_1^2)x_0'x_2'} + \underline{x_1'x_2'} + \underline{2\omega_1x_1'x_2'} - \frac{1}{2}x_2^2 - x_0x_2 - x_1x_2 - \varepsilon x_0^3x_2 - 3\varepsilon x_0^2x_1x_2 \right] d\tau.$$

Integrating the underlined terms by parts taking into account the periodicity of $x_0(\tau)$ and $x_1(\tau)$, we reduce this formula to

$$I_2[x_2(\tau)] = \int_0^{2\pi} \left[\frac{1}{2}x_2'^2 + \underline{2\omega_1x_0x_2} + (2\omega_2 + \omega_1^2)x_0x_2 - \underline{x_1''x_2} - 2\omega_1x_1''x_2 - \frac{1}{2}x_2^2 - \underline{x_1x_2} - \underline{\varepsilon x_0^3x_2} - 3\varepsilon x_0^2x_1x_2 \right] d\tau.$$

Using the equations for x_1 and ω_1 , it is easy to check that the underlined terms are canceled out. Besides, the last term can be transformed into the sum of harmonic cosine functions as follows

$$-3\varepsilon x_0^2x_1x_2 = -\frac{3}{128}\varepsilon^2a^5(-2\cos\tau + \cos 3\tau + \cos 5\tau)x_2.$$

Finally, we have

$$I_2[x_2(\tau)] = \int_0^{2\pi} \left[\frac{1}{2}x_2'^2 - \frac{1}{2}x_2^2 + \underline{(2\omega_2a + \omega_1^2a + \frac{3}{64}\varepsilon^2a^5 - \frac{1}{16}\omega_1\varepsilon a^3)\cos\tau x_2} + \dots \right] d\tau.$$

Removing the underlined (resonant) term, we get

$$2\omega_2 = -\omega_1^2 - \frac{3}{64}\varepsilon^2a^4 + \frac{3}{128}\varepsilon^2a^4, \quad \text{that is,} \quad \omega_2 = -\frac{21}{256}\varepsilon^2a^4.$$

Thus, the correction for the frequency-amplitude relation reads

$$\omega = 1 + \frac{3}{8}\varepsilon a^2 - \frac{21}{256}\varepsilon^2a^4.$$

The period $T = 2\pi/\omega$ may then be written as

$$T = \frac{2\pi}{1 + \frac{3}{8}\varepsilon a^2 - \frac{21}{256}\varepsilon^2a^4} = 2\pi \left[1 - \frac{3}{8}\varepsilon a^2 + \frac{57}{256}\varepsilon^2a^4 \right].$$

EXERCISE 5.3. Consider a mass-spring oscillator with an asymmetric spring obeying the equation

$$\ddot{x} + x + \varepsilon x^2 = 0.$$

Find the period of vibration for $\varepsilon = 0.1$ and $x(0) = 1, \dot{x}(0) = 0$ using the numerical integration based on (5.3). Compare it with the result obtained by the variational-asymptotic method.

Solution. The potential energy of the spring is

$$U(x) = \frac{1}{2}x^2 + \frac{\varepsilon}{3}x^3.$$

We compute the period of vibration according to

$$T = 2 \int_{x_m}^{x_M} \frac{d\xi}{\sqrt{2[E_0 - U(\xi)]}},$$

where E_0 is the total energy (which is conserved) and x_m and x_M are the turning points. From the initial conditions we find

$$E_0 = \frac{1}{2}v_0^2 + \frac{1}{2}x_0^2 + \frac{\varepsilon x_0^3}{3} = \frac{1}{2} + \frac{\varepsilon}{3} = 0.533.$$

Since the point-mass is released from $x = 1$, this value corresponds to the turning point $x_M = 1$. The other turning point is found as the root of the equation

$$U(x) = U(1) = E_0 \quad \Rightarrow \quad x_m = -1.0718.$$

Using the numerical integration, we find that

$$T = 2 \int_{x_m}^{x_M} \frac{d\xi}{\sqrt{2[E_0 - U(\xi)]}} \approx 6.312.$$

To establish the asymptotic formula for the period of vibration we analyze the action functional

$$I[x(\tau)] = \int_0^{2\pi} \left(\frac{1}{2}\omega^2 x'^2 - \frac{1}{2}x^2 - \frac{1}{3}\varepsilon x^3 \right) d\tau.$$

Then the first step of the variational-asymptotic procedure yields

$$x(\tau) = x_0(\tau) = a \cos \tau, \quad \omega = 1.$$

We have chosen the initial phase $\phi = 0$ which is consistent with the above initial conditions. At the second step we look for the solution in the form

$$x(\tau) = x_0(\tau) + x_1(\tau), \quad \omega = 1 + \omega_1.$$

Repeating similar calculations as in Section 5.1, we arrive at the following functional

$$I_1[x_1(\tau)] = \int_0^{2\pi} \left[\frac{1}{2}x_1'^2 - \frac{1}{2}x_1^2 + \underline{2\omega_1 a \cos \tau x_1} - \frac{1}{2}\varepsilon a^2(1 + \cos 2\tau)x_1 \right] d\tau.$$

Since the underlined term is the only resonant term and since $x_1(0) = x_1'(0) = 0$, we find that

$$\omega_1 = 0, \quad x_1(\tau) = \frac{1}{6}\varepsilon a^2(-3 + 2\cos\tau + \cos 2\tau).$$

At the third step we substitute

$$x(\tau) = x_0(\tau) + x_1(\tau) + x_2(\tau), \quad \omega = 1 + \omega_2$$

into the action functional. Repeating similar calculations as in the previous exercise, we obtain

$$I_2[x_2(\tau)] = \int_0^{2\pi} \left(\frac{1}{2}x_2'^2 - \frac{1}{2}x_2^2 + 2\omega_2 x_0 x_2 - 2\varepsilon x_0 x_1 x_2 \right) d\tau.$$

The last term can be transformed into the sum of harmonic cosine functions as follows

$$-2\varepsilon x_0 x_1 x_2 = -\varepsilon^2 a^3 \frac{1}{6}(2 - 5\cos\tau + 2\cos 2\tau + \cos 3\tau).$$

Thus, the resonant term is

$$(2\omega_2 a + \frac{5}{6}\varepsilon^2 a^3) \cos\tau x_2.$$

Removing this resonant term, we get

$$\omega_2 = -\frac{5}{12}\varepsilon^2 a^2.$$

Thus, the refined frequency-amplitude relation reads

$$\omega = 1 - \frac{5}{12}\varepsilon^2 a^2.$$

The period $T = 2\pi/\omega$ may then be written as

$$T = 2\pi \left(1 + \frac{5}{12}\varepsilon^2 a^2 \right) \approx 6.309.$$

EXERCISE 5.4. Find and classify the fixed points of equation (5.14) of a damped pendulum for all $c > 0$, and plot the phase portraits for the qualitatively different cases.

Solution. Equation (5.14) can be written in the dimensionless form as

$$\varphi'' + 2\delta\varphi' + \sin\varphi = 0,$$

where prime denotes the derivative with respect to $\tau = \omega_0 t$, and $\delta = \frac{c}{2m\omega_0}$ is Lehr's damping ratio. Transforming this equation to

$$\begin{aligned}\varphi' &= \omega, \\ \omega' &= -\sin \varphi - 2\delta\omega,\end{aligned}$$

we see that the fixed points should be

$$(\varphi_n, \omega_n), \quad \text{where } \varphi_n = n\pi, \quad \omega_n = 0,$$

and n are integers. Due to the periodicity in φ with the period 2π only the fixed points corresponding to $n = 0$ and $n = 1$ need be analyzed. For $n = 0$ linearization near the fixed point $(0, 0)$ gives

$$\begin{aligned}\varphi' &= \omega, \\ \omega' &= -\varphi - 2\delta\omega,\end{aligned}$$

which is equivalent to

$$\varphi'' + 2\delta\varphi' + \varphi = 0.$$

Thus, if $0 < \delta < 1$ the fixed point is a stable focus, and if $\delta > 1$ it is a stable node. For $n = 1$ linearization near the fixed point $(\pi, 0)$ with $\varphi = \pi + u$ and $\omega = v$ gives

$$\begin{aligned}u' &= v, \\ v' &= u - 2\delta v.\end{aligned}$$

The corresponding characteristic equation

$$\lambda^2 + 2\delta\lambda - 1 = 0$$

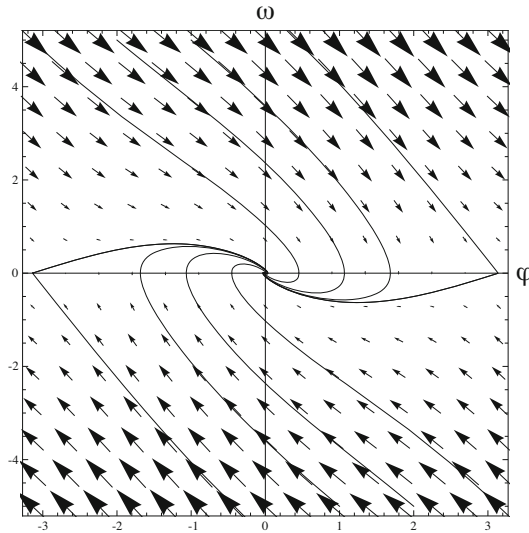

Fig. 5.25 Phase portrait of overdamped pendulum

has one negative real root $\lambda_1 = -\delta - \sqrt{\delta^2 + 1}$ and one positive real root $\lambda_2 = -\delta + \sqrt{\delta^2 + 1}$. Thus, the fixed point is a saddle point for all positive δ . The phase portrait for $\delta < 1$ (underdamped pendulum) was shown in Fig. 5.8. For the case $\delta > 1$ corresponding to the overdamped pendulum, the phase portrait is shown in Fig. 5.25. It is seen that the fixed point $(0, 0)$ is a stable node, while the fixed point $(\pi, 0)$ remains a saddle point.

EXERCISE 5.5. The motion of a mass-spring oscillator with the linear restoring force $-kx$ ($k = 2\text{N/cm}$) is damped by a constant braking force $f_r = 1\text{N}$; this force acts however only in the region $-1\text{cm} \leq x \leq 1\text{cm}$. Outside this region the oscillator carries out a free vibration. Find the sequence of turning points and the number of halves of vibrations for the initial conditions $x = -3\text{cm}$ and $\dot{x} = 0$.

Solution. Outside the region $-1\text{cm} \leq x \leq 1\text{cm}$ there is no braking force, so the energy must be conserved

$$\frac{1}{2}m\dot{x}^2 + \frac{1}{2}kx^2 = E_0.$$

In the region $-1\text{cm} \leq x \leq 1\text{cm}$ the braking force causes the energy dissipation according to

$$\frac{1}{2}m\dot{x}^2 + \frac{1}{2}kx^2 = E_0 - f_r|x - x_0|.$$

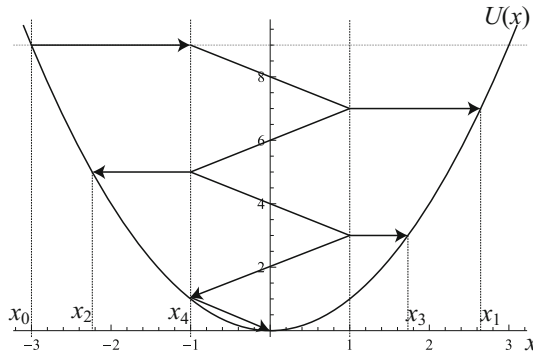

Fig. 5.26 Energy change and the sequence of turning points

With these two equations we can construct the sequence of the turning points as shown in Fig. 5.26. Being released from $x_0 = -3\text{cm}$ with the zero velocity, the oscillator has the initial energy $E_0 = \frac{1}{2}kx_0^2 = 9\text{Ncm}$. From -3cm to -1cm the total energy does not change. After passing the zone with braking force the total energy is reduced by 2Ncm . Then the oscillator moves to the turning point without changing the energy $E_1 = 7\text{Ncm}$. Thus, the turning point $x_1 = \sqrt{7}\text{cm}$. Similar arguments can again be applied for the oscillator moving now to the left. After passing the zone with braking force the total energy becomes $E_2 = 5\text{Ncm}$, so the next turning

point is $x_2 = -\sqrt{5}\text{cm}$. Analogously, the next two turning points are $x_3 = \sqrt{3}\text{cm}$ and $x_4 = -1\text{cm}$ corresponding to the total energies $E_3 = 3\text{Ncm}$ and $E_4 = 1\text{Ncm}$. The oscillator ends its motion at point $x = 0\text{cm}$ which is inside the sticky zone $-0.5\text{cm} \leq x \leq 0.5\text{cm}$.

EXERCISE 5.6. Consider a damped pendulum with “turbulent” damping described by the equation

$$\ddot{\varphi} + c\dot{\varphi}|\dot{\varphi}| + \omega_0^2 \sin \varphi = 0.$$

Find the sequence of turning angles.

Solution. As shown in example considered in Section 5.2, the above equation can be integrated separately for $\dot{\varphi} > 0$ and $\dot{\varphi} < 0$. For $\dot{\varphi} > 0$ this equation can be rewritten in the form

$$\frac{dv^2}{d\varphi} + \alpha v^2 + \beta \sin \varphi = 0,$$

with $v = \dot{\varphi}$, $\alpha = 2c$, $\beta = 2\omega_0^2$. Applying the method of variation of coefficients, we obtain

$$v^2(\varphi) = e^{-\alpha\varphi} \left(C_1 - \beta \int_0^\varphi \sin \xi e^{\alpha\xi} d\xi \right).$$

Similarly, for $\dot{\varphi} < 0$ we have

$$v^2(\varphi) = e^{\alpha\varphi} \left(C_2 - \beta \int_0^\varphi \sin \xi e^{-\alpha\xi} d\xi \right).$$

The constants C_1 and C_2 should be determined from the initial conditions. Let

$$U_+(\varphi) = \beta \int_0^\varphi \sin \xi e^{\alpha\xi} d\xi = \frac{\beta}{1 + \alpha^2} [1 + e^{\alpha\varphi} (-\cos \varphi + \alpha \sin \varphi)],$$

$$U_-(\varphi) = \beta \int_0^\varphi \sin \xi e^{-\alpha\xi} d\xi = \frac{\beta}{1 + \alpha^2} [1 - e^{-\alpha\varphi} (\cos \varphi + \alpha \sin \varphi)].$$

Assume that the pendulum is released from φ_0 with the zero angular velocity $v_0 = 0$ and that it rotates afterward in the positive direction. Then $C_1 = U_+(\varphi_0)$ and

$$v^2(\varphi) = e^{-\alpha\varphi} [U_+(\varphi_0) - U_+(\varphi)] \quad \text{for } \dot{\varphi} > 0.$$

The first turning point φ_1 can then be found as the root of the equation $U_+(\varphi_1) = U_+(\varphi_0)$. Choosing now φ_1 as the initial angle from which the pendulum is released and rotates in the negative direction, we find that $C_2 = U_-(\varphi_1)$ and that

$$v^2(\varphi) = e^{\alpha\varphi} [U_-(\varphi_1) - U_-(\varphi)] \quad \text{for } \dot{\varphi} < 0.$$

Therefore, the second turning point, φ_2 , must be the root of the equation $U_-(\varphi_2) = U_-(\varphi_1)$. Then we can choose φ_2 as the initial angle from which the pendulum is released and repeat the procedure. For the above functions the constant factors and the constant summands do not obviously influence the determination of the turning points. So, instead of $U_+(\varphi)$ and $U_-(\varphi)$ we can take the following functions

$$U_+^*(\varphi) = e^{\alpha\varphi}(-\cos\varphi + \alpha\sin\varphi) \quad \text{and} \quad U_-^*(\varphi) = -e^{-\alpha\varphi}(\cos\varphi + \alpha\sin\varphi)$$

for this purpose. Besides, $U_+^*(\varphi) = U_-^*(-\varphi)$, so it is enough to plot them for $\varphi > 0$. Fig. 5.27 shows the plots of these functions (for $c = 1/2$) and the geometric method of determining the sequence of turning points.

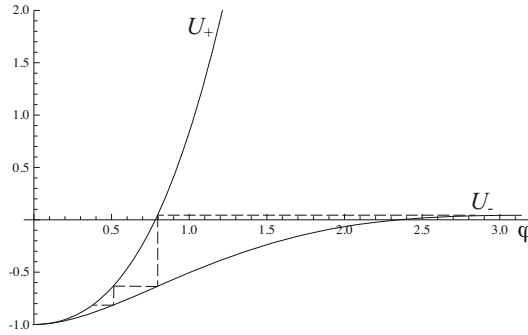

Fig. 5.27 Functions $U_+^*(\varphi)$ and $U_-^*(\varphi)$ and sequence of turning points

EXERCISE 5.7. Consider Froude’s pendulum described by the following dimensionless equation

$$\ddot{\varphi} + 2\delta\dot{\varphi} + \omega_0^2 \sin\varphi = m_r(\dot{\varphi} - v_0),$$

where

$$2\delta = \frac{c}{J}, \quad \omega_0^2 = \frac{mgl}{J}, \quad m_r = \frac{M_r}{J}.$$

Find conditions under which this oscillator develops self-sustained vibrations.

Solution. The above equation of motion is equivalent to the system of equations

$$\begin{aligned} \varphi' &= y, \\ y' &= m_r(y - v_0) - 2\delta y - \omega_0^2 \sin\varphi, \end{aligned}$$

which has one fixed point S on the φ -axis with the coordinate $\varphi = \varphi_0$, where

$$\varphi_0 = \arcsin \frac{m_r(-v_0)}{\omega_0^2}.$$

To know whether this equilibrium position is stable or not, we study the neighboring solutions assumed in the form

$$\varphi = \varphi_0 + u, \quad y = v,$$

and linearize the system with respect to u and v . Since

$$m_r(v - v_0) = m_r(-v_0) + \left. \frac{dm_r}{dv} \right|_{-v_0} v + O(v^2), \quad \sin \varphi = \sin \varphi_0 + u \cos \varphi_0 + O(u^2),$$

and $m_r(-v_0) - \omega^2 \sin \phi_0 = 0$ at the fixed point S, we obtain

$$u' = v, \quad v' = \left(\left. \frac{dm_r}{dv} \right|_{-v_0} - 2\delta \right) v - \omega_0^2 \cos \varphi_0 u,$$

what is equivalent to the equation

$$u'' - \left(\left. \frac{dm_r}{dv} \right|_{-v_0} - 2\delta \right) u' + \omega_0^2 \cos \varphi_0 u = 0.$$

Thus, if

$$\left. \frac{dm_r}{dv} \right|_{-v_0} > 2\delta,$$

then the fixed point is an unstable focus, and the phase curves starting near this fixed point are repelled from it.

The vector field and phase curves of this pendulum are quite similar to those of the stick-slip oscillator shown in Fig. 5.20. The phase curves hitting the horizontal line $y = v_0$ must change their slopes abruptly when crossing this line. By this reason the line $y = v_0$ is called a jump line. Besides, there is a “sticky” zone $\arcsin((-r_0 - 2\delta v_0)/\omega_0^2) < \varphi < \arcsin((r_0 - 2\delta v_0)/\omega_0^2)$ on this jump line (the segment AC), where r_0 denotes the critical threshold moment of the friction. When the phase curves hit this sticky zone, they have to move along the horizontal line up to point C with coordinates $(\arcsin((r_0 - 2\delta v_0)/\omega_0^2), v_0)$, where the pendulum is detached from the rotating shaft and the slip begins.¹⁰ The phase curve starting from point C is a spiral, which hit the segment AC at point B if the damping ratio δ is small. This phase curve together with the segment BC correspond to the limit cycle of the Froude’s pendulum.

EXERCISE 5.8. Consider the mechanical system governed by the differential equation

$$\ddot{x} - \varepsilon \sin \dot{x} + x = 0.$$

Construct several phase curves for $\varepsilon = 0.1$ using numerical integration. Show that more than one limit cycle exist. Use the variational-asymptotic method to calculate the amplitudes of limit cycles.

Solution. The above equation can be written as the system

$$\dot{x} = y, \quad \dot{y} = -x + \varepsilon \sin y,$$

¹⁰ Note, however, that this detach point C exists only if $r_0 \leq \omega_0^2 + 2\delta v_0$. For larger threshold values r_0 the pendulum will rotate with the shaft without being detached from it.

for which the numerical integration with the command *NDSolve* in *Mathematica* is applicable as demonstrated in Section 5.3. If we set $\varepsilon = 0.1$ and take the initial conditions $x(0) = 3, y(0) = 0$, and $x(0) = 5, y(0) = 0$, the corresponding phase curves, shown in Fig. 5.28, enable one to guess that there exists one stable limit cycle whose amplitude is near the value 4. Likewise, the phase curves starting at $x(0) = 9, y(0) = 0$, and $x(0) = 11, y(0) = 0$ show that another stable limit cycle whose amplitude near the value 10 exists.

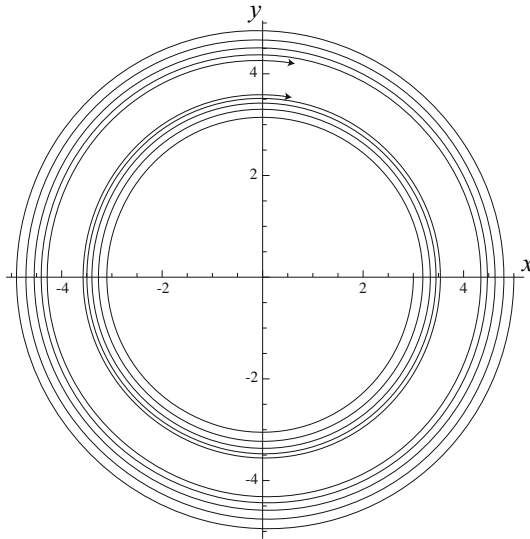

Fig. 5.28 Two phase curves starting at $x(0) = 3, y(0) = 0$, and $x(0) = 5, y(0) = 0$

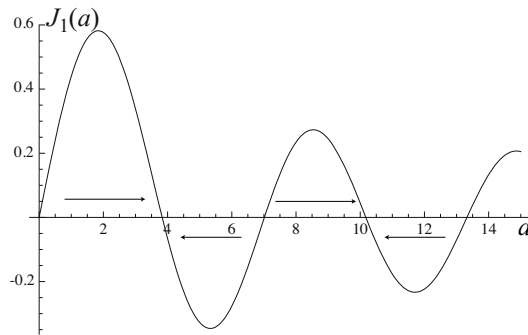

Fig. 5.29 The plot of $J_1(a)$ and the directions of change of a according to $a, \eta = J_1(a)$ as η goes to infinity

According to the variational-asymptotic method, the slow evolution of the amplitudes of vibrations to those of the limit cycles and the corrections to the frequencies for small ε are determined from the equations

$$a_{,\eta} = -\frac{1}{2\pi} \int_0^{2\pi} f(a \cos \tau, -a \sin \tau) \sin \tau d\tau,$$

$$\omega_1 = -\frac{\varepsilon}{2\pi a} \int_0^{2\pi} f(a \cos \tau, -a \sin \tau) \cos \tau d\tau,$$

where

$$f(x, \dot{x}) = \sin \dot{x}.$$

The integrals on the right-hand sides yield

$$a_{,\eta} = J_1(a), \quad \omega_1 = 0,$$

where $J_1(a)$ is the Bessel function, whose plot is shown in Fig. 5.29. Thus, there is no correction to the frequency. The evolution equation for a cannot be solved in terms of special functions, but as seen from Fig. 5.29, the zeros of $J_1(a)$ at which $J_1'(a)$ is negative give the amplitudes of the stable limit cycles. This yields

$$a_1 = 3.83171, \quad a_2 = 10.1735, \dots$$

EXERCISE 5.9. Show that Rayleigh's equation

$$\ddot{x} + x - \varepsilon \left(1 - \frac{1}{3} \dot{x}^2\right) \dot{x} = 0$$

can be rewritten as van der Pol's equation

$$\ddot{u} + u - \varepsilon(1 - u^2)\dot{u} = 0,$$

where $u = \dot{x}$. Find the amplitude of its limit cycle for small ε .

Solution. Let us differentiate Rayleigh's equation using the definition $u = \dot{x}$

$$\ddot{u} + u - \varepsilon \dot{u} + \varepsilon u^2 \dot{u} = 0.$$

We see that this is exactly van der Pol's differential equation in terms of u . On the other side, Rayleigh's equation in terms of x contains a small parameter ε , so the slow evolution of the amplitude of vibration and the correction to the frequency are determined from the equations

$$a_{,\eta} = -\frac{1}{2\pi} \int_0^{2\pi} f(a \cos \tau, -a \sin \tau) \sin \tau d\tau,$$

$$\omega_1 = -\frac{\varepsilon}{2\pi a} \int_0^{2\pi} f(a \cos \tau, -a \sin \tau) \cos \tau d\tau,$$

where

$$f(x, \dot{x}) = (1 - \frac{1}{3}\dot{x}^2)\dot{x}.$$

We compute the integrals on the right-hand sides of these equations

$$\begin{aligned} -\frac{1}{2\pi} \int_0^{2\pi} f(a \cos \tau, -a \sin \tau) \sin \tau d\tau &= \frac{1}{2\pi} \int_0^{2\pi} (1 - \frac{1}{3}a^2 \sin^2 \tau) a \sin^2 \tau d\tau \\ &= \frac{a}{8}(4 - a^2), \end{aligned}$$

and

$$\int_0^{2\pi} f(a \cos \tau, -a \sin \tau) \cos \tau d\tau = -\int_0^{2\pi} (1 - \frac{1}{3}a^2 \sin^2 \tau) a \sin \tau \cos \tau d\tau = 0.$$

Thus, there is no correction to the frequency. The evolution equation for a is exactly the same as that obtained for the van der Pol oscillator

$$a, \eta = \frac{a}{8}(4 - a^2).$$

The solution to this equation reads

$$a = \frac{2a_0 e^{\epsilon\tau/2}}{\sqrt{4 + a_0^2(e^{\epsilon\tau} - 1)}},$$

where a_0 is the initial amplitude of vibration. So, the amplitude of vibration tends to the value 2 as $\tau \rightarrow \infty$. This result is also confirmed by the numerical integration of Rayleigh's equation with $\epsilon = 0.1$ as shown in Fig. 5.30.

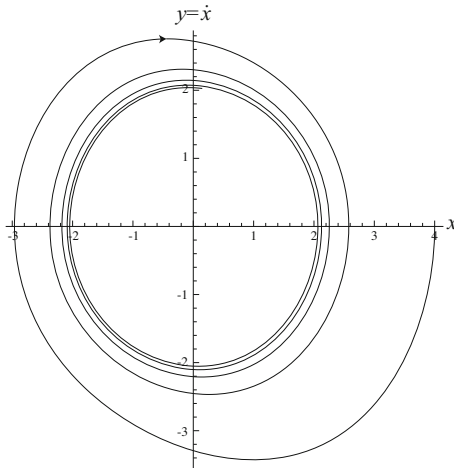

Fig. 5.30 A phase curve of Rayleigh's equation beginning from $(x, y) = (4, 0)$

EXERCISE 5.10. Consider the equation

$$\ddot{x} + x + \mu(|x| - 1)\dot{x} = 0.$$

Find the approximate period and amplitude of the limit cycle for small μ .

Solution. For small μ let the slow time be $\eta = \mu\tau$. Then the slow evolution of the amplitude of vibration and the correction to the frequency are determined from the equations

$$a_{,\eta} = \frac{1}{2\pi} \int_0^{2\pi} (1 - a|\cos\tau|)a\sin^2\tau d\tau = -\frac{a(4a - 3\pi)}{6\pi},$$

$$\omega_1 = \frac{\varepsilon}{2\pi a} \int_0^{2\pi} (1 - a|\cos\tau|)a\sin\tau\cos\tau d\tau = 0.$$

Thus, there is no correction to the frequency. The equation for a can be integrated to give

$$\ln \frac{4a - 3\pi}{4a} = -\eta/2 + C.$$

The constant of integration can be obtained from the initial condition $a(0) = a_0$: $C = \ln \frac{4a_0 - 3\pi}{4a_0}$. Substituting this constant in the last equation and solving it with respect to a we obtain

$$a = \frac{3\pi}{4(1 - \frac{4a_0 - 3\pi}{4a_0}e^{-\eta/2})}.$$

Thus, a approaches $3\pi/4$ as $\tau \rightarrow \infty$.

EXERCISE 5.11. Use the variational-asymptotic method to study the equation

$$\ddot{x} + x - \varepsilon(1 - x^4)\dot{x} = 0$$

for small ε . Find the approximate amplitude of the limit cycle.

Solution. The slow evolution of the amplitude of vibration and the correction to the frequency are determined from the equations

$$a_{,\eta} = \frac{1}{2\pi} \int_0^{2\pi} (1 - a^4\cos^4\tau)a\sin^2\tau d\tau = \frac{a}{16}(8 - a^4),$$

$$\omega_1 = \frac{\varepsilon}{2\pi a} \int_0^{2\pi} (1 - a^4\cos^4\tau)a\sin\tau\cos\tau d\tau = 0.$$

Thus, there is no correction to the frequency. The equation for a can be transformed by multiplying it with $4a^3$

$$z_{,\eta} = \frac{1}{4}z(8 - z),$$

where $z = a^4$. This equation can be integrated by separating the variables giving

$$\ln \frac{z}{8 - z} = 2\eta + C.$$

The constant of integration can be obtained from the initial condition $z(0) = z_0$: $C = \ln \frac{z_0}{8-z_0}$. Substituting this constant into the last equation and solving it with respect to z , we obtain

$$z = \frac{8z_0 e^{2\eta}}{8 - z_0 + z_0 e^{2\eta}},$$

or, in terms of the original amplitude a and time τ

$$a^4 = \frac{8a_0^4 e^{2\varepsilon\tau}}{8 - a_0^4 + a_0^4 e^{2\varepsilon\tau}}.$$

Thus, a approaches $\sqrt[4]{8} \approx 1.682$ as $\tau \rightarrow \infty$. This result is also confirmed by the numerical integration of the equation for x (with $\varepsilon = 0.1$) as shown in Fig. 5.31.

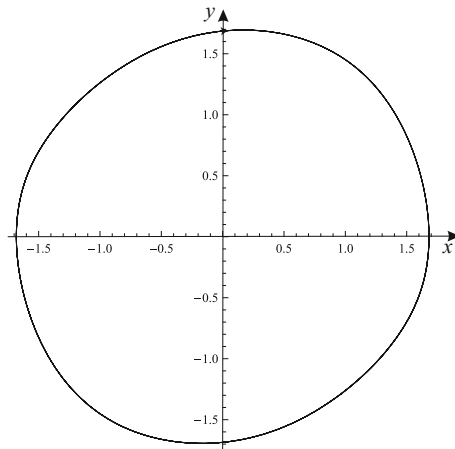

Fig. 5.31 Limit cycle of the equation $\ddot{x} + x - 0.1(1 - x^4)\dot{x} = 0$

EXERCISE 5.12. Use the variational-asymptotic method to study the equation

$$\ddot{x} + x - \mu(1 + x - x^2)\dot{x} = 0,$$

where μ is a large parameter. Find the amplitude and period of the limit cycle. Compare the results with those obtained by numerical integration for $\mu = 10$.

Solution. The above equation is obtained from the following variational equation

$$\delta \int_{t_0}^{t_1} \left(\frac{1}{2} \dot{x}^2 - \frac{1}{2} x^2 \right) dt + \int_{t_0}^{t_1} \mu(1 + x - x^2) \dot{x} \delta x dt = 0.$$

Numerical simulations for large μ (see, for instance, Fig. 5.32 in case $\mu = 10$) show that the solution corresponding to the limit cycle spends most of time in a slow

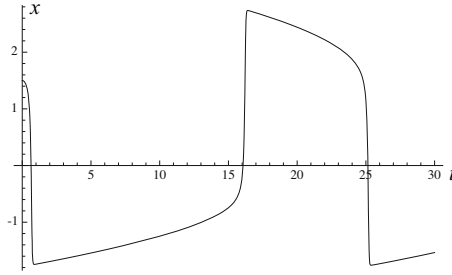

Fig. 5.32 Numerical solution of the equation $\dot{x} + x - 10(1 + x - x^2)\dot{x} = 0$

motion, and then quickly jumps to another slow motion. To analyze slow motions we introduce the slow time $\eta = t/\mu$ and transform the variational equation to

$$\delta \int_{\eta_0}^{\eta_1} \left(\frac{1}{2\mu^2} x_{,\eta}^2 - \frac{1}{2} x^2 \right) d\eta + \int_{\eta_0}^{\eta_1} (1 + x - x^2) x_{,\eta} \delta x d\eta = 0.$$

Neglecting the first term in this equation as small in accordance with the variational-asymptotic method, we arrive at the equation

$$-x + (1 + x - x^2)x_{,\eta} = 0, \quad \text{or} \quad x_{,\eta} = \frac{x}{1 + x - x^2}.$$

This differential equation can be solved by separation of variables yielding

$$\ln|x| + x - \frac{x^2}{2} = \eta + \text{const.}$$

The slow motion proceeds according to this equation until it reaches $x_{1,2} = (1 \pm \sqrt{5})/2$ where the speed $x_{,\eta}$ is infinite. At these points the assumption of slow motion is violated, so we need to change to another time scale. Introducing now the fast time $\tau = \mu t$, we rewrite the variational equation as

$$\delta \int_{\tau_0}^{\tau_1} \left(\frac{1}{2} \mu^2 x_{,\tau}^2 - \frac{1}{2} x^2 \right) d\tau + \int_{\tau_0}^{\tau_1} \mu^2 (1 + x - x^2) x_{,\tau} \delta x d\tau = 0.$$

Neglecting the second term as small compared with other terms, we arrive at the differential equation

$$x_{,\tau\tau} - (1 + x - x^2)x_{,\tau} = 0.$$

This equation possesses the first integral

$$x_{,\tau} - x - x^2/2 + x^3/3 = \text{const},$$

representing the fast motion (jump). We choose the constant of integration so that this fast motion starting at $x = x_1$ ($x = x_2$) as an equilibrium point (with $x_{,\tau} = 0$) will end at another equilibrium point with $x_{,\tau} = 0$. It is easy to see that the second

equilibrium point corresponding to x_1 is $x = 2.736$. Similarly, the jump starting at x_2 ends up at $x = -1.736$. Knowing the solution, we can easily compute the period of this relaxation oscillation. The comparison with the solution obtained by the numerical integration for $\mu = 10$ shown in Fig. 5.32 yields a good agreement.

Chapter 6

Non-autonomous Single Oscillator

This Chapter analyzes non-autonomous mechanical systems with one degree of freedom whose Lagrange function depends explicitly on time. This involves either some time-dependent parameter or a harmonic excitation. The variational-asymptotic analysis, combined with multi-scaling, belongs again to the arsenal of mostly used analytical methods of solution of variational problems containing small parameters.

6.1 Parametrically-Excited Oscillator

Differential Equation of Motion. If some parameter of an oscillator changes in such a way that the energy supply is synchronized with the period of vibration, the parametric resonance may occur. We consider some examples.

EXAMPLE 6.1. Pendulum with periodically moving support. The support of a pendulum moves in accordance with the equation $x = a(t)$ (see Fig. 6.1). Derive the equation of motion for this pendulum.

In a fixed (x, y) -coordinate system the coordinates of the point-mass are

$$x = a + l \cos \varphi, \quad y = l \sin \varphi.$$

Differentiating these equations with respect to t we obtain the velocity

$$\dot{x} = \dot{a} - l \sin \varphi \dot{\varphi}, \quad \dot{y} = l \cos \varphi \dot{\varphi}.$$

Therefore the kinetic energy is equal to

$$K = \frac{1}{2}m(\dot{x}^2 + \dot{y}^2) = \frac{1}{2}m(\dot{a}^2 - 2l \sin \varphi \dot{a} \dot{\varphi} + l^2 \dot{\varphi}^2).$$

The potential energy of the point mass is

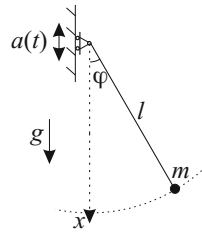

Fig. 6.1 Pendulum with moving support

$$U = -mg(a + l \cos \varphi).$$

Note that the zero level of potential energy corresponds to $x = 0$. Thus, the Lagrange function $L(\varphi, \dot{\varphi}, t) = K - U$ depends explicitly on time through $a(t)$. Mechanical systems with the Lagrange function depending explicitly on time are classified as non-autonomous. Substitution of this Lagrange function into Lagrange's equation gives

$$ml^2 \ddot{\varphi} + mgl \sin \varphi - ml\ddot{a} \sin \varphi = 0,$$

or

$$\ddot{\varphi} + \frac{1}{l}(g - \ddot{a}) \sin \varphi = 0. \quad (6.1)$$

If $a(t)$ is a periodic function of t , say $a(t) = a_0 \cos \omega t$, then (6.1) is a nonlinear equation with periodic coefficients. In order to investigate the stability of one of the equilibrium positions $\varphi = 0$ or $\varphi = \pi$, we would linearize (6.1) about the desired equilibrium. In case $\varphi = 0$ the linearization yields

$$\ddot{\varphi} + \frac{1}{l}(g + a_0 \omega^2 \cos \omega t) \varphi = 0. \quad (6.2)$$

This is called Mathieu's equation [35]. We will show later that the parametric resonance may occur for some values of ω and a_0 .

EXAMPLE 6.2. Stability of a limit cycle.

Assume that $x = x_s(t)$ is a periodic solution of the equation of motion

$$\ddot{x} = f(x, \dot{x}). \quad (6.3)$$

We would like to study the dynamic stability of this periodic solution. For this purpose we investigate the neighboring solutions

$$x = x_s(t) + \xi(t), \quad \dot{x} = \dot{x}_s(t) + \dot{\xi}(t), \quad \ddot{x} = \ddot{x}_s(t) + \ddot{\xi}(t),$$

where $\xi(t)$ and its first derivative are assumed to be small. Substituting these formulas into the equation of motion, we obtain

$$\ddot{x}_s(t) + \ddot{\xi}(t) = f(x_s(t) + \xi(t), \dot{x}_s(t) + \dot{\xi}(t)).$$

Since $\xi(t)$ and $\dot{\xi}(t)$ are small, we expand the right-hand side into the Taylor series and neglect all nonlinear terms

$$\begin{aligned} f(x_s(t) + \xi(t), \dot{x}_s(t) + \dot{\xi}(t)) &= f(x_s, \dot{x}_s) + \frac{\partial f}{\partial x}(x_s(t), \dot{x}_s(t)) \xi(t) \\ &\quad + \frac{\partial f}{\partial \dot{x}}(x_s(t), \dot{x}_s(t)) \dot{\xi}(t) + \dots \end{aligned}$$

Taking into account that $x_s(t)$ is the solution of (6.3), we obtain for $\xi(t)$

$$\ddot{\xi} = \frac{\partial f}{\partial x}(x_s(t), \dot{x}_s(t))\xi(t) + \frac{\partial f}{\partial \dot{x}}(x_s(t), \dot{x}_s(t))\dot{\xi}(t).$$

Thus, the stability analysis of a limit cycle puts a question, whether or not the linear differential equation with periodic coefficients has bounded solutions. This is quite similar to the problem of parametric resonance.

EXAMPLE 6.3. Pendulum with periodically changeable length $l(t)$ (see Fig. 6.2).

The swing known from our childhood is described by this mechanical model. The kinetic and potential energies of the point-mass are

$$K = \frac{1}{2}ml^2(t)\dot{\phi}^2, \quad U = mgl(t)(1 - \cos \phi).$$

Lagrange’s equation has the form

$$ml^2\ddot{\phi} + 2ml\dot{l}\dot{\phi} + mgl \sin \phi = 0.$$

Dividing this equation by ml^2 we obtain

$$\ddot{\phi} + 2\frac{\dot{l}}{l}\dot{\phi} + \frac{g}{l} \sin \phi = 0.$$

In reality, the change of length of the swing is realized by the motion of the swinger. This changes the center of gravity causing the change of the effective length of the physical pendulum. To pump the swing the swinger must raise his or her body as the swing passes through the lowest point and lower themselves near the extremes of the motion.

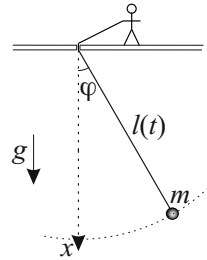

Fig. 6.2 Pendulum with changeable length

Solution in a Simplified Model of Swing. To get the “feeling” of how the parametric resonance may occur, we analyze a simplified model of swing, in which the effective length of the pendulum changes abruptly from l_1 to l_2 at $\phi = 0$, and from l_2 to l_1 as the maximum (or minimum) of ϕ is achieved at the turning angle. The trajectory of the center of mass is shown in Fig. 6.3 by a loop with arrows. Since $l = l_1 = \text{const}$ in the first quarter of vibration, energy must be conserved if the air resistance is neglected

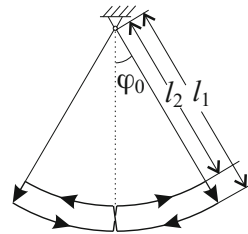

Fig. 6.3 A simplified model of swing

$$\frac{1}{2}ml_1^2\dot{\phi}^2 + mgl_1(1 - \cos \phi) = mgl_1(1 - \cos \phi_0),$$

where ϕ_0 is the starting angle when the swing is released. Using this equation we can compute the angular velocity $\dot{\phi}$ just before the change of length at $\phi = 0$

$$\dot{\phi}_{1-}^2 = \frac{2g}{l_1}(1 - \cos \phi_0). \tag{6.4}$$

Similarly, in the next quarter of vibration in which the swing's length is $l = l_2 = \text{const}$, we have

$$\frac{1}{2}ml_2^2\dot{\varphi}^2 + mgl_2(1 - \cos \varphi) = mgl_2(1 - \cos \varphi_2),$$

where φ_2 is the turning angle, so the angular velocity immediately after the change of length at $\varphi = 0$ is equal to

$$\dot{\varphi}_{1+}^2 = \frac{2g}{l_2}(1 - \cos \varphi_2). \quad (6.5)$$

During the short time when the length of the swing changes abruptly the force in the radial direction is applied. Since the moment of this radial force about the support is zero, the angular momentum must be conserved

$$ml_1^2\dot{\varphi}_{1-} = ml_2^2\dot{\varphi}_{1+}. \quad (6.6)$$

This relation can be used to determine φ_2 through φ_0 . Indeed, squaring (6.6) and using (6.4) and (6.5) we get

$$l_1^3(1 - \cos \varphi_0) = l_2^3(1 - \cos \varphi_2). \quad (6.7)$$

Similar arguments lead to the generalization of this equation for all subsequent halves of vibration

$$l_1^3(1 - \cos \varphi_{2(n-1)}) = l_2^3(1 - \cos \varphi_{2n}).$$

Thus, the sequence of turning angles can be constructed geometrically as shown in Fig. 6.4. Starting from the point $A_0 = (\varphi_0, f_1(\varphi_0))$ on the curve $f_1(\varphi) = l_1^3(1 - \cos \varphi)$ we find the next turning angle φ_2 at the intersection between the horizontal line going through A_0 and the curve $f_2(\varphi) = l_2^3(1 - \cos \varphi)$. Then, starting from $A_2 = (\varphi_2, f_1(\varphi_2))$ we find the next turning angle φ_4 , and the whole process can be continued. We see that after a finite number of halves of vibration the angle may become larger than π .

It is interesting to find out the energy gain after each swing act. Obviously, the energy does not change during the time when $l = \text{const}$. As the length of the swing changes abruptly from l_1 to l_2 , the energy gain is

$$E_g = mgh + \frac{1}{2}m(v_{1+}^2 - v_{1-}^2),$$

where $h = l_1 - l_2$. The first term is the gain of potential energy, the second term corresponds to the increase of kinetic energy. Taking into account (6.4)-(6.6) and $v = l\dot{\varphi}$, we express E_g in terms of φ_0

$$E_g = mg\{h + l_1(1 - \cos \varphi_0)[(l_1/l_2)^2 - 1]\}.$$

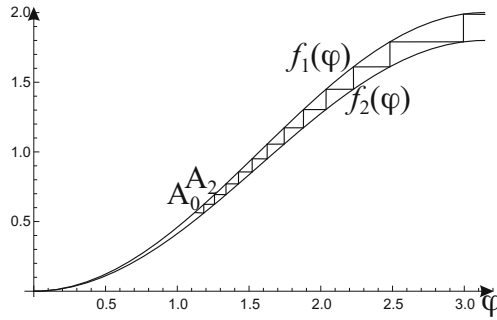

Fig. 6.4 Sequence of turning angles

After the change of the length from l_2 to l_1 at the turning angle φ_2 we have the loss of potential energy

$$E_l = mgh \cos \varphi_2.$$

Thus, the total energy gain in a half of vibration is equal to

$$\Delta E = E_g - E_l = mg \{ h(1 - \cos \varphi_2) + l_1(1 - \cos \varphi_0)[(l_1/l_2)^2 - 1] \}.$$

Recalling (6.7), this can be transformed to

$$\Delta E = \frac{h(l_1^2 + l_1 l_2 + l_2^2)}{l_2^3} mg l_1 (1 - \cos \varphi_0) = k E_0,$$

where $k = h(l_1^2 + l_1 l_2 + l_2^2)/l_2^3$ and E_0 is the initial energy. Thus, the energy after the first half of vibration is

$$E_2 = E_0 + \Delta E = E_0(1 + k).$$

Similar formulas can be derived for the subsequent halves of vibration. Thus, the energy after n halves of vibration becomes

$$E_{2n} = E_0(1 + k)^n.$$

We see that the energy grows in a geometrical progression, like an accumulation of a capital invested with the interest rate k . In reality, this energy accumulation is reduced by the energy loss due to the drag force of the air so that a stationary regime may be established under certain conditions.

Numerical Solutions. We turn now to Mathieu's equation (6.2) as the prototype equation describing parametrically excited oscillators. We present it in the form¹

$$\ddot{x} + (\mu + \varepsilon \cos t)x = 0. \tag{6.8}$$

¹ It is easy to show that equation (6.2) assumes this form with $\mu = (\omega_0/\omega)^2$, $\varepsilon = a_0/l$, and $\omega_0 = \sqrt{g/l}$, if time is replaced by the dimensionless time ωt .

The main concern of this equation is whether or not all solutions are bounded for given values of the parameters μ and ε . If all solutions are bounded, then the corresponding point in the (μ, ε) -plane is said to be stable. In the opposite case we have the parametric resonance and the point is classified as unstable. The problem is to find the stability chart of Mathieu's equation.

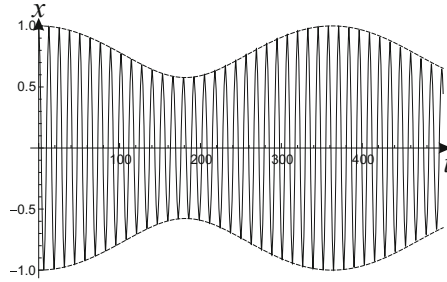

Fig. 6.5 Solution of Mathieu's equation for $\mu = 0.24$ and $\varepsilon = 0.01$

Although equation (6.8) can be solved analytically in terms of Mathieu's functions [3], it is even simpler first to find a solution for some μ and ε by numerical integration. Similar commands in *Mathematica* like those presented in Section 5.3 work quite well. Fig. 6.5 shows the solution $x(t)$ satisfying the initial conditions $x(0) = 1$, $\dot{x}(0) = 0$, for $\mu = 0.24$ and $\varepsilon = 0.01$. We can observe that there are two characteristic time scales: i) one describing the period of fast oscillation of $x(t)$, ii) the other associated with the slow oscillation of amplitude of vibration marked by the dashed envelopes. The solution remains bounded in this case.

If we change parameters μ and ε a little bit, the character of solutions may change radically. For example, if we take $\mu = 0.25$ while keeping $\varepsilon = 0.01$ as before, then the solution satisfying the same initial conditions shown in Fig. 6.6 exhibits the exponential growth of the amplitude. So, it is reasonable to guess that the point $(0.25, 0.01)$ of the (μ, ε) -plane causes the parametric resonance. Also in this case we can observe two characteristic time scales: i) one describing the period of fast

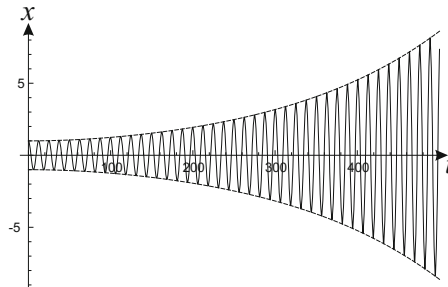

Fig. 6.6 Solution of Mathieu's equation for $\mu = 0.25$ and $\varepsilon = 0.01$

oscillation of $x(t)$, ii) the other associated with the exponential growth of amplitude of vibration marked by the dashed envelopes.

It should be noted, however, that the numerical integration, which is quite useful when studying the behavior of particular solutions, is not appropriate for the determination of the stability chart of Mathieu’s equation. This is due to two reasons. First, these numerical simulations cannot be provided for an infinite time interval, so the boundedness of solutions cannot strictly be proved. Second, one cannot do infinite number of numerical simulations for all possible values of μ and ε as well as for all possible initial data. Thus, other more “intelligent” methods should be developed for this purpose.

Variational-Asymptotic Method. Let us find the approximate solutions to Mathieu’s equation for small ε by using the variational-asymptotic method. These solutions are also the extremals of the functional

$$I[x(t)] = \int_{t_0}^{t_1} \left[\frac{1}{2} \dot{x}^2 - \frac{1}{2} (\mu + \varepsilon \cos t) x^2 \right] dt, \tag{6.9}$$

with t_0 and t_1 being arbitrary time instants. For short we set $t_0 = 0, t_1 = T$. At the first step we put simply $\varepsilon = 0$ to get from (6.9)

$$I_0[x(t)] = \int_0^T \left(\frac{1}{2} \dot{x}^2 - \frac{1}{2} \mu x^2 \right) dt.$$

The extremal of $I_0[x(t)]$ satisfies the equation

$$\ddot{x} + \mu x = 0$$

yielding the periodic solution with the period $T = 2\pi/\sqrt{\mu}$

$$x_0(t) = A \cos \sqrt{\mu}t + B \sin \sqrt{\mu}t. \tag{6.10}$$

Taking into account that the coefficients A and B are becoming slightly dependent on time for $\varepsilon \neq 0$, we introduce the slow time $\eta = \varepsilon t$ and seek the corrections to the extremal at the second step in the two-timing fashion

$$x(t) = A(\eta) \cos \sqrt{\mu}t + B(\eta) \sin \sqrt{\mu}t + x_1(t, \eta), \tag{6.11}$$

where $x_1(t, \eta)$ is a periodic function of the period T with respect to t and is much smaller than $x_0(t, \eta)$ in the asymptotic sense. The time derivative of $x(t)$ becomes

$$\dot{x} = -A\sqrt{\mu} \sin \sqrt{\mu}t + \varepsilon A_{,\eta} \cos \sqrt{\mu}t + B\sqrt{\mu} \cos \sqrt{\mu}t + \varepsilon B_{,\eta} \sin \sqrt{\mu}t + x_{1,t} + \varepsilon x_{1,\eta}.$$

Substituting (6.11) into (6.9) and keeping the asymptotically principal terms containing x_1 and the principal cross terms between x_0 and x_1 , we obtain

$$\begin{aligned}
I_1[x_1(t)] = & \int_0^T \left[\frac{1}{2}x_{1,t}^2 - \underline{A\sqrt{\mu} \sin \sqrt{\mu}t x_{1,t}} + \underline{B\sqrt{\mu} \cos \sqrt{\mu}t x_{1,t}} \right. \\
& + \underline{\varepsilon A_{,\eta} \cos \sqrt{\mu}t x_{1,t}} + \underline{\varepsilon B_{,\eta} \sin \sqrt{\mu}t x_{1,t}} - \frac{1}{2}\mu x_1^2 - \underline{\mu A \cos \sqrt{\mu}t x_1} \\
& \left. - \underline{\mu B \sin \sqrt{\mu}t x_1} - \varepsilon \cos t (A \cos \sqrt{\mu}t + B \sin \sqrt{\mu}t)x_1 \right] dt.
\end{aligned}$$

Integrating the second up to fifth terms by parts taking into account the periodicity of $x_1(t)$ we see that the underlined terms give $2\varepsilon\sqrt{\mu}(A_{,\eta} \sin \sqrt{\mu}t - B_{,\eta} \cos \sqrt{\mu}t)x_1$. Besides, the products $\cos t \cos \sqrt{\mu}t$ and $\cos t \sin \sqrt{\mu}t$ can be transformed into the sum of harmonic functions like that

$$\begin{aligned}
\cos t \cos \sqrt{\mu}t &= \frac{1}{2}[\cos(1 + \sqrt{\mu})t + \cos(1 - \sqrt{\mu})t], \\
\cos t \sin \sqrt{\mu}t &= \frac{1}{2}[\sin(1 + \sqrt{\mu})t - \sin(1 - \sqrt{\mu})t],
\end{aligned}$$

so finally we obtain

$$\begin{aligned}
I_1[x_1(t)] = & \int_0^T \left[\frac{1}{2}x_{1,t}^2 - \frac{1}{2}\mu x_1^2 + 2\varepsilon A_{,\eta}\sqrt{\mu} \sin \sqrt{\mu}t x_1 - 2\varepsilon B_{,\eta}\sqrt{\mu} \cos \sqrt{\mu}t x_1 \right. \\
& - \frac{1}{2}\varepsilon A(\cos(1 + \sqrt{\mu})t + \cos(1 - \sqrt{\mu})t)x_1 \\
& \left. - \frac{1}{2}\varepsilon B(\sin(1 + \sqrt{\mu})t - \sin(1 - \sqrt{\mu})t)x_1 \right] dt. \tag{6.12}
\end{aligned}$$

For a general value of μ removal of resonant terms yields the trivial equations

$$A_{,\eta} = 0, \quad B_{,\eta} = 0.$$

Thus, for general μ the $\cos t$ term has no effect. However, if $\sqrt{\mu} = 1 - \sqrt{\mu}$, i.e. $\mu = 1/4$, then there are additional contributions to the resonant terms. In this case removal of resonant terms gives the slow flow

$$\begin{aligned}
A_{,\eta} &= -\frac{1}{2}B, \\
B_{,\eta} &= -\frac{1}{2}A.
\end{aligned}$$

These equations lead to $A_{,\eta\eta} = A/4$. Thus, A and B involve exponential growth, and the parameter value $\mu = 1/4$ causes instability. This corresponds to a 2:1 subharmonic resonance in which the driving frequency is twice the natural frequency as in the example of swing.

Let us seek the correction for μ in the neighborhood of $1/4$ in the form

$$\mu = \frac{1}{4} + \mu_1,$$

where μ_1 is much smaller than 1. This brings additional resonant terms of the form $-\mu_1(A \cos \frac{t}{2} + B \sin \frac{t}{2})x_1$ into functional (6.12). Thus, the equations for A and B change to

$$A_{,\eta} = \left(\frac{\mu_1}{\varepsilon} - \frac{1}{2}\right)B, \quad B_{,\eta} = -\left(\frac{\mu_1}{\varepsilon} + \frac{1}{2}\right)A. \tag{6.13}$$

This means, $A_{,\eta\eta} + (\mu_1^2/\varepsilon^2 - 1/4)A = 0$, and A and B will be sine and cosine functions of η if $\mu_1^2 > \varepsilon^2/4$. That is, if either $\mu_1 > \varepsilon/2$ or $\mu_1 < -\varepsilon/2$, then A and B remain bounded. Thus, the following two curves in the (μ, ε) -plane represent stability changes, and are called transition curves:

$$\mu = \frac{1}{4} \pm \frac{\varepsilon}{2} + O(\varepsilon^2). \tag{6.14}$$

These two curves emanate from the point $\mu = 1/4$ on the μ -axis and define a region of instability called a *tongue*. Inside the tongue, for small ε , x grows exponentially in time. Outside the tongue x is the sum of terms, each of which is the product of two harmonic functions with generally incommensurate frequencies, so x is a bounded quasiperiodic function of t . This confirms our numerical simulations done in the previous paragraph. One can also show that the approximate solution given by equations (6.10) and (6.13) converges to the exact solution of (6.8) in any finite time interval as $\varepsilon \rightarrow 0$. The indirect check of this result can be done also by solving equations (6.13) and comparing it with the numerical solutions (see the dashed envelopes in Figs. 6.5 and 6.6 computed by the equations (6.13)).

6.2 Mathieu’s Differential Equation

This Section presents the exact treatment of Mathieu’s equation based on Floquet’s theory of linear differential equations with periodic coefficients and the finding of stability chart.

Floquet’s Theory. We first study the general theory of linear differential equations with periodic coefficients (Floquet’s theory). Let \mathbf{x} be an $n \times 1$ column vector, and \mathbf{A} an $n \times n$ matrix whose elements are periodic functions with a period T . We consider the following vectorial differential equation

$$\dot{\mathbf{x}} = \mathbf{A}(t)\mathbf{x}. \tag{6.15}$$

Notice that, since $\mathbf{A}(t+T) = \mathbf{A}(t)$, this equation is invariant with respect to the shift of time by a constant period T . Thus, if $\mathbf{x}(t)$ is a solution of (6.15), then $\mathbf{x}(t+T)$ must also be a solution of (6.15).

Now let us consider the fundamental solution matrix of (6.15), $\mathbf{X}(t)$, which is defined as follows. $\mathbf{X}(t)$ is an $n \times n$ matrix, whose columns are solutions of (6.15) such that $\mathbf{X}(0) = \mathbf{I}$, \mathbf{I} being the identity matrix. As the columns of $\mathbf{X}(t)$ are linearly independent, they form a basis for the n -dimensional solution space of (6.15). Since $\mathbf{X}(t+T)$ is also the solution matrix of equation (6.15), each of its columns may be written as a linear combination of the columns of $\mathbf{X}(t)$, so

$$\mathbf{X}(t+T) = \mathbf{X}(t)\mathbf{C}, \quad (6.16)$$

where \mathbf{C} is a $n \times n$ constant matrix. At $t = 0$ we have $\mathbf{X}(T) = \mathbf{X}(0)\mathbf{C} = \mathbf{C}$, so \mathbf{C} is in fact equal to the fundamental matrix evaluated at time T . Thus, \mathbf{C} could be obtained by numerically integrating (6.15) from $t = 0$ to $t = T$, n times, once for each of the n initial conditions satisfied by the i -th column of $\mathbf{X}(0)$. Taking the time instants $2T$, $3T$, and so on and applying similar arguments, we can show that $\mathbf{X}(nT) = \mathbf{C}^n$.

Let us transform (6.16) to normal coordinates. We seek another fundamental solution matrix $\mathbf{Y}(t)$ such that

$$\mathbf{Y}(t) = \mathbf{X}(t)\mathbf{R},$$

where \mathbf{R} is as yet unknown $n \times n$ matrix. Combining this equation with (6.16), we obtain

$$\mathbf{Y}(t+T) = \mathbf{Y}(t)\mathbf{R}^{-1}\mathbf{C}\mathbf{R}. \quad (6.17)$$

Suppose that \mathbf{C} has n linearly independent eigenvectors. If we choose the columns of \mathbf{R} to be these eigenvectors, then the product $\mathbf{R}^{-1}\mathbf{C}\mathbf{R}$ will be a diagonal matrix with the eigenvalues λ_i of \mathbf{C} on its diagonal. With $\mathbf{R}^{-1}\mathbf{C}\mathbf{R}$ diagonal, the matrix $\mathbf{Y}(t)$ satisfying (6.17) will also be diagonal. Indeed, let us construct this diagonal matrix explicitly. Its elements satisfy the equations

$$y_i(t+T) = \lambda_i y_i(t). \quad (6.18)$$

We look for a solution to this functional equation in the form

$$y_i(t) = \lambda_i^{kt} p_i(t),$$

where k is an unknown constant and $p_i(t)$ is an unknown function. Substitution into (6.18) gives

$$y_i(t+T) = \lambda_i^{k(t+T)} p_i(t+T) = \lambda_i(\lambda_i^{kt} p_i(t)).$$

This equation is satisfied if we take $k = 1/T$ and $p_i(t)$ a periodic function of period T . Thus, the constructed matrix with the diagonal elements

$$y_i(t) = \lambda_i^{t/T} p_i(t) \quad (6.19)$$

satisfies (6.17). This implies that the original system (6.15) will be stable if every eigenvalue λ_i of \mathbf{C} has modulus less than 1. In the opposite case the solution will grow exponentially as $t \rightarrow \infty$ leading to instability and parametric resonance.

Hill's Equation. Let us first apply Floquet's theory to Hill's equation

$$\ddot{x} + f(t)x = 0, \quad f(t+T) = f(t),$$

which contains Mathieu's equation as a special case. This equation can be written as a system of differential equation

$$\frac{d}{dt} \begin{pmatrix} x \\ y \end{pmatrix} = \begin{pmatrix} 0 & 1 \\ -f(t) & 0 \end{pmatrix} \begin{pmatrix} x \\ y \end{pmatrix}.$$

We construct a fundamental solution matrix from two solution vectors satisfying the initial conditions

$$\begin{pmatrix} x_1(0) \\ y_1(0) \end{pmatrix} = \begin{pmatrix} 1 \\ 0 \end{pmatrix}, \quad \begin{pmatrix} x_2(0) \\ y_2(0) \end{pmatrix} = \begin{pmatrix} 0 \\ 1 \end{pmatrix}.$$

Then the matrix \mathbf{C} is the fundamental solution matrix evaluated at time T

$$\mathbf{C} = \begin{pmatrix} x_1(T) & x_2(T) \\ y_1(T) & y_2(T) \end{pmatrix}.$$

From the previous paragraph we know that stability is determined by the eigenvalues of \mathbf{C}

$$\lambda^2 - (\text{tr}\mathbf{C})\lambda + \det\mathbf{C} = 0, \tag{6.20}$$

where $\text{tr}\mathbf{C}$ and $\det\mathbf{C}$ are the trace and determinant of \mathbf{C} . It turns out that $\det\mathbf{C} = 1$ for Hill's equation. Indeed, let us compute the time derivative of the Wronskian

$$\frac{d}{dt}W(t) = \frac{d}{dt}(x_1y_2 - y_1x_2) = y_1y_2' - f(t)x_1x_2' + f(t)x_1x_2 - y_1y_2' = 0.$$

Thus, $W(T) = \det\mathbf{C} = W(0) = 1$ and equation (6.20) can be written as

$$\lambda^2 - (\text{tr}\mathbf{C})\lambda + 1 = 0,$$

yielding two roots

$$\lambda_{1,2} = \frac{1}{2}(\text{tr}\mathbf{C} \pm \sqrt{(\text{tr}\mathbf{C})^2 - 4}).$$

According to Floquet's theory instability occurs if either eigenvalue has modulus larger than 1. So, if $|\text{tr}\mathbf{C}| > 2$, then we have two real roots, and since their product is 1, one of them has modulus greater than 1. In this case we have instability associated with the exponential growth of solutions. If $|\text{tr}\mathbf{C}| < 2$, then the roots are complex conjugate, and since their product is 1, they lie on the unit circle, with the consequence that the solutions are bounded. The transition from stable to unstable behavior corresponds to those parameter values giving $|\text{tr}\mathbf{C}| = 2$. If $\text{tr}\mathbf{C} = 2$, then we have the double root $\lambda = 1$, and formula (6.19) implies that the solutions must be periodic functions with period T . In case $\text{tr}\mathbf{C} = -2$ we have the double root $\lambda = -1$ corresponding to the periodic solutions with period $2T$. Thus, on the transition curves in parameter space, the motions are periodic with period T or $2T$. In accordance with this theory, the stability of a given pair (μ, ε) can be determined by finding the fundamental solution matrix at $t = T$ through numerical integration and investigating its eigenvalues. However, for the whole (μ, ε) -plane the method is still ineffective.

Stability Chart. In case of Mathieu's equation the period of $f(t)$ is 2π , so we may seek the periodic solutions on the transition curves in form of a Fourier series

$$x(t) = \sum_{j=0}^{\infty} \left(a_j \cos \frac{jt}{2} + b_j \sin \frac{jt}{2} \right).$$

The factor $1/2$ in the arguments of sine and cosine guarantees that periodic functions of period 4π are included. Substituting this Fourier series into Mathieu's equation (6.8), transforming the products of trigonometric functions into harmonic functions and collecting similar terms gives four sets of homogeneous linear equations on the coefficients a_j and b_j . Each set contains only coefficients a_j or b_j with even or odd indices j . For a nontrivial solution of one set to exist the corresponding determinant must vanish. This gives four infinite determinants known as Hill's determinants. For a_j with even j we have

$$\begin{vmatrix} \mu & \varepsilon/2 & 0 & 0 \\ \varepsilon & \mu - 1 & \varepsilon/2 & 0 & \dots \\ 0 & \varepsilon/2 & \mu - 4 & \varepsilon/2 \\ & & \dots & \end{vmatrix} = 0.$$

For b_j with even j ,

$$\begin{vmatrix} \mu - 1 & \varepsilon/2 & 0 & 0 \\ \varepsilon/2 & \mu - 4 & \varepsilon/2 & 0 & \dots \\ 0 & \varepsilon/2 & \mu - 9 & \varepsilon/2 \\ & & \dots & \end{vmatrix} = 0.$$

For a_j with odd j ,

$$\begin{vmatrix} \mu - 1/4 + \varepsilon/2 & \varepsilon/2 & 0 & 0 \\ \varepsilon/2 & \mu - 9/4 & \varepsilon/2 & 0 & \dots \\ 0 & \varepsilon/2 & \mu - 25/4 & \varepsilon/2 \\ & & \dots & \end{vmatrix} = 0.$$

Finally, for b_j with odd j ,

$$\begin{vmatrix} \mu - 1/4 - \varepsilon/2 & \varepsilon/2 & 0 & 0 \\ \varepsilon/2 & \mu - 9/4 & \varepsilon/2 & 0 & \dots \\ 0 & \varepsilon/2 & \mu - 25/4 & \varepsilon/2 \\ & & \dots & \end{vmatrix} = 0.$$

In all four determinants the typical row is

$$\dots \quad 0 \quad \varepsilon/2 \quad \mu - j^2/4 \quad \varepsilon/2 \quad 0 \quad \dots$$

except for the first one or two rows.

Each of these equations represents a relation between μ and ε , which plots as a set of transition curves in the (μ, ε) -plane (see Fig. 6.7). Since the transition curves are symmetric about the μ -axis, only the upper half of chart is shown. The equations obtained at $\varepsilon = 0$ give the intersections of these curves with the μ -axis. For a_j or b_j with even j the transition curves intersect the μ -axis at $\mu = j^2$, $j = 0, 1, 2, \dots$, while

those curves obtained from the determinants with odd j intersect the μ -axis at $\mu = (2j + 1)^2/4, j = 0, 1, 2, \dots$ For $\varepsilon > 0$, each of these points give rise to two transition curves, one obtained from the a -determinant, and the other from the b -determinant. Thus, there is a tongue of instability emanating from each of the following points on the μ -axis: $\mu = j^2/4, j = 0, 1, 2, \dots$ Exception is the case $j = 0$ for which only one transition curve exists.

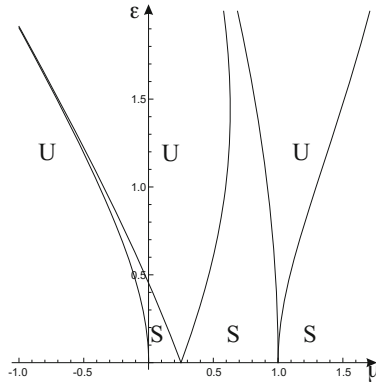

Fig. 6.7 Stability chart of Mathieu's equation (U: unstable, S: stable)

To find the asymptote of a transition curve $\mu = f(\varepsilon)$ emanating from $j^2/4$ on the μ -axis we expand the function $f(\varepsilon)$ in the power series

$$\mu = \frac{j^2}{4} + \mu_1\varepsilon + \mu_2\varepsilon^2 + \dots \tag{6.21}$$

Substituting this into one of the determinants and equating terms of equal order of ε to zero, we can determine the coefficients μ_i . For example, for $j = 1$ we may take the truncated 3×3 a -determinant with odd j to obtain

$$-\frac{\varepsilon^3}{8} - \frac{\mu\varepsilon^2}{2} + \frac{13\varepsilon^2}{8} + \frac{\mu^2\varepsilon}{2} - \frac{17\mu\varepsilon}{4} + \frac{225\varepsilon}{32} + \mu^3 - \frac{35\mu^2}{4} + \frac{259\mu}{16} - \frac{225}{64} = 0.$$

Substituting (6.21) (with $j = 1$) into the above equation and equating terms with ε and ε^2 to zero, we obtain $\mu_1 = -1/2$ and $\mu_2 = -1/8$. This procedure can be continued to any order of truncation. Here are the asymptotes of first five transition curves computed in this way

$$\mu = \begin{cases} -\frac{\varepsilon^2}{2} & \text{for } j = 0 \\ \frac{1}{4} - \frac{\varepsilon}{2} - \frac{\varepsilon^2}{8} & \text{for } j = 1 \\ \frac{1}{4} + \frac{\varepsilon}{2} - \frac{\varepsilon^2}{8} & \text{for } j = 1 \\ 1 - \frac{\varepsilon^2}{12} & \text{for } j = 2 \\ 1 + \frac{5\varepsilon^2}{12} & \text{for } j = 2 \end{cases}$$

Note that the transition curves (6.14) obtained in Section 6.1 by the variational-asymptotic method corresponds to $j = 1$. Why other tongues of instability were missed? If we continue the next steps of the variational-asymptotic method, the other tongues can be found also (see exercise 6.3).

6.3 Duffing’s Forced Oscillator

Differential Equation of Motion. As we know from Section 5.2 the free vibrations of a nonlinear damped oscillator must decay as time increases because of the positive dissipation rate. We want now to analyze the situation, when some external harmonic force acts on such the oscillator. As prototype we consider a damped Duffing’s oscillator subjected to a small harmonic excitation. For this forced oscillator the displacement $x(t)$ satisfies the variational equation

$$\delta \int_{t_0}^{t_1} \left(\frac{1}{2} \dot{x}^2 - \frac{1}{2} x^2 - \frac{1}{4} \varepsilon \alpha x^4 + \varepsilon \hat{f} \cos \omega t x \right) dt - \int_{t_0}^{t_1} \varepsilon c \dot{x} \delta x dt = 0, \tag{6.22}$$

where ε is a small parameter. This implies the following equation of motion

$$\ddot{x} + x + \varepsilon c \dot{x} + \varepsilon \alpha x^3 = \varepsilon \hat{f} \cos \omega t. \tag{6.23}$$

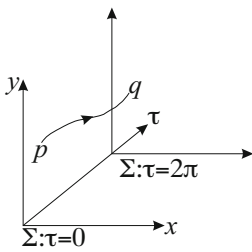

Fig. 6.8 Poincaré map

$$\begin{aligned} \dot{x} &= y, \\ \dot{y} &= -x - \varepsilon c y - \varepsilon \alpha x^3 + \varepsilon \hat{f} \cos \tau \\ \dot{\tau} &= \omega. \end{aligned}$$

This system of three differential equations of first order is defined on a phase space with topology $R^2 \times S$, where the circle S comes from the 2π -periodicity in τ of the vector field. A convenient way to view this 3-D flow in two dimensions is to use the Poincaré map. This map is obtained by the intersection of the trajectory with a plane of section Σ which may be taken as $\tau = 0 \pmod{2\pi}$ as shown schematically in Fig. 6.8. Thus, when $\hat{f} = 0$, the equilibria that would normally lie in the (x, y) -plane, now become periodic orbits of period 2π in this 3-D phase space. For small $\hat{f} > 0$, we may expect by a continuity argument that these periodic orbits persist giving rise to 2π -periodic motions. Such periodic motions correspond to fixed points of the Poincaré map.

Numerical Solutions. Since no analytical solution to the forced Duffing equation (6.23) is available, we first try to find some particular solutions by numerical integration to study their behavior. Take for example $\varepsilon = 0.1$, $c = 0$, $\alpha = 1$. For the harmonic force we choose $\hat{f} = 1$ and $\omega = 1$, together with the initial conditions $x(0) = 1$, $\dot{x}(0) = 0$. The numerical integration with standard commands like those in Section 5.3 gives the graph of $x(t)$ shown in Fig. 6.9. Looking at this solution, we observe that there are two time scales characterizing the vibration: i) one describing the period of fast oscillation of $x(t)$, ii) the other associated with the slow and periodic change of amplitude of vibration.

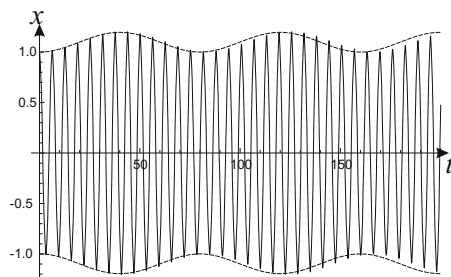

Fig. 6.9 Numerical solution of forced Duffing equation for $\omega = 1$

It turns out that for certain values of frequency and amplitude of force as well as certain initial conditions, purely periodic solutions can be obtained. This corresponds to a fixed point of the Poincaré's map introduced in the previous paragraph. For example, if we take $\omega = 0.9875$ while keeping all other parameters unchanged, the solution is purely periodic as seen in Fig. 6.10.

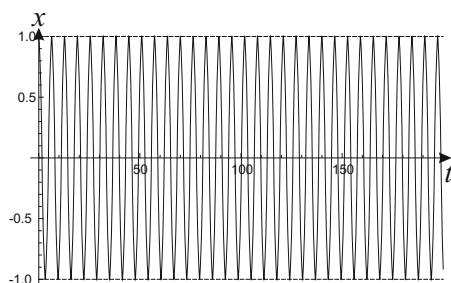

Fig. 6.10 Numerical solution of forced Duffing equation for $\omega = 0.9875$

As soon as the damping becomes nonzero, the character of solutions changes. Take for example $\varepsilon = 0.1$, $c = \alpha = \hat{f} = 1$, $\omega = 1$, together with the initial conditions $x(0) = 1$, $\dot{x}(0) = 0$. Now the amplitude shows first a transient character before approaching a certain steady-state amplitude that depends only on the forcing

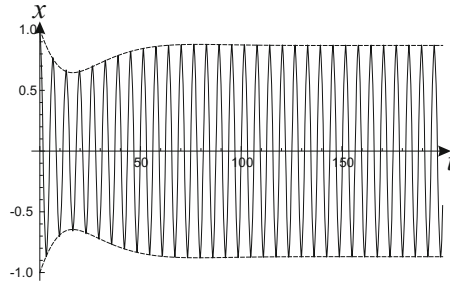

Fig. 6.11 Numerical solution of forced and damped Duffing oscillator for $c = 1$ and $\omega = 1$

frequency and the initial conditions (see Fig. 6.11). The steady-state response frequency coincides with the forcing frequency, what is similar to the linear theory.

If we increase the forcing frequency while keeping all other parameters as well as the initial conditions, the steady-state amplitude may become even smaller as shown in Fig. 6.12 for the case $\omega = 1.2$. Since we cannot do infinite number of numerical simulations to establish the behavior of slow change of amplitude due to the change of frequency and other factors, more “intelligent” methods have to be invented for this purpose.

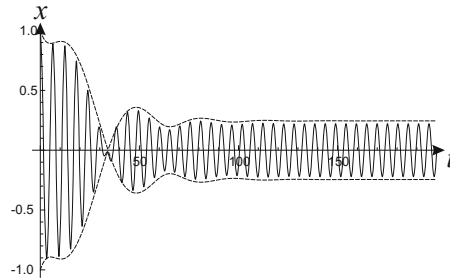

Fig. 6.12 Numerical solution of forced and damped Duffing oscillator for $c = 1$ and $\omega = 1.2$

Variational-Asymptotic Method. For the convenience of our analysis let us introduce the stretched angular time $\tau = \omega t$ explicitly in the variational equation (6.22). Since $\dot{x} = \omega x'$, where prime denotes the derivative with respect to τ , equation (6.22) becomes

$$\delta \int_{\tau_0}^{\tau_0+2\pi} \left(\frac{1}{2} \omega^2 x'^2 - \frac{1}{2} x^2 - \frac{1}{4} \varepsilon \alpha x^4 + \varepsilon \hat{f} \cos \tau x \right) d\tau - \int_{\tau_0}^{\tau_0+2\pi} \varepsilon c \omega x' \delta x d\tau = 0, \tag{6.24}$$

where $\tau_1 = \tau_0 + 2\pi$ and τ_0 is an arbitrary time instant. For short we set $\tau_0 = 0$.

At the first step of the variational-asymptotic procedure we neglect all terms containing ε to get

$$\delta \int_0^{2\pi} \left(\frac{1}{2} \omega^2 x'^2 - \frac{1}{2} x^2 \right) d\tau = 0.$$

The 2π -periodic extremal of this variational problem is

$$x_0(\tau) = A \cos \tau + B \sin \tau.$$

We see that the frequency equals 1 which is not surprising because the external force, the damping and the nonlinear spring force are neglected. The coefficients A and B are still unknown and should be determined from the initial conditions.

From the numerical simulations provided previously we know that, for $\varepsilon \neq 0$, the coefficients A and B are becoming dependent on time. In general the forcing frequency differs from 1 also. Taking all these circumstances into account, we introduce the slow time $\eta = \varepsilon \tau$ and search for the corrections to the extremal and to the frequency at the second step in the form

$$x(\tau) = A(\eta) \cos \tau + B(\eta) \sin \tau + x_1(\tau, \eta), \quad \omega = 1 + \omega_1, \quad (6.25)$$

where $x_1(\tau, \eta)$ is a 2π -periodic function with respect to τ and is much smaller than $x_0(\tau, \eta) = A(\eta) \cos \tau + B(\eta) \sin \tau$ in the asymptotic sense, and ω_1 is assumed to be much smaller than 1. The second equation of (6.25) means that we are restricting to the case where the forcing frequency is nearly equal to 1. The full time derivative of x is equal to

$$x' = x_{0,\tau} + \varepsilon x_{0,\eta} + x_{1,\tau} + \varepsilon x_{1,\eta}. \quad (6.26)$$

We substitute (6.25) and (6.26) into (6.24) and keep the asymptotically principal terms containing x_1 and the principal cross terms between x_0 and x_1 . The variational equation becomes

$$\begin{aligned} \delta \int_0^{2\pi} \left[\frac{1}{2} x_{1,\tau}^2 + \underline{x_{0,\tau} x_1'} + \underline{\varepsilon x_{0,\eta} x_1'} + 2\omega_1 x_{0,\tau} x_1' \right. \\ \left. - \frac{1}{2} x_1^2 - \underline{x_0 x_1} - \varepsilon \alpha x_0^3 x_1 + \varepsilon \hat{f} \cos \tau x_1 - \varepsilon c x_{0,\tau} x_1 \right] d\tau = 0. \end{aligned}$$

Next, we integrate the second, third, and fourth terms by parts using the 2π -periodicity of x_1 with respect to τ . It is easy to see that, since $(x_{0,\tau})' = -x_0 + \varepsilon x_{0,\tau\eta}$, the underlined terms give $-2\varepsilon x_{0,\eta} x_1$. Then we expand x_0^3 of the term $-\varepsilon \alpha x_0^3 x_1$ and transform the products of sine and cosine into the sum of harmonic functions according to

$$\begin{aligned} \cos^3 \tau &= \frac{3}{4} \cos \tau + \frac{1}{4} \cos 3\tau, & \cos^2 \tau \sin \tau &= \frac{1}{4} (\sin \tau + \sin 3\tau), \\ \sin^3 \tau &= \frac{3}{4} \sin \tau - \frac{1}{4} \sin 3\tau, & \sin^2 \tau \cos \tau &= \frac{1}{4} (\cos \tau - \cos 3\tau). \end{aligned}$$

The variational equation takes the form

$$\delta \int_0^{2\pi} \left[\frac{1}{2} x_1^2{}_{,\tau} - \frac{1}{2} x_1^2 + (\dots) \sin \tau x_1 + (\dots) \cos \tau x_1 + \text{nonresonant terms} \right] d\tau = 0.$$

The consistency condition requires the expressions in parentheses to vanish, giving the following equations for A and B

$$\begin{aligned} 2A_{,\eta} + cA + 2\frac{\omega_1}{\varepsilon}B - \frac{3}{4}\alpha B(A^2 + B^2) &= 0, \\ 2B_{,\eta} + cB - 2\frac{\omega_1}{\varepsilon}A + \frac{3}{4}\alpha A(A^2 + B^2) &= \hat{f}. \end{aligned} \quad (6.27)$$

The fixed points of these equations correspond to periodic motions of the forced Duffing equation (6.23). To find them we set $A_{,\eta}$ and $B_{,\eta}$ equal to zero. Multiplying the first equation of (6.27) by A and adding it to the second equation multiplied by B gives

$$ca^2 = \hat{f}B, \quad \text{where } a^2 = A^2 + B^2.$$

Similarly, multiplying the first equation of (6.27) by B and subtracting it from the second one multiplied by A yields

$$-2\frac{\omega_1}{\varepsilon}a^2 + \frac{3}{4}\alpha a^4 = \hat{f}A.$$

Adding the squares of two last equations together and dividing by a^2 we obtain

$$a^2 \left[c^2 + \left(-2\frac{\omega_1}{\varepsilon} + \frac{3}{4}\alpha a^2 \right)^2 \right] = \hat{f}^2.$$

Solving the last equation with respect to ω_1 leads to

$$\omega_1 = \frac{3}{8}\varepsilon\alpha a^2 \pm \frac{1}{2}\varepsilon \sqrt{\frac{\hat{f}^2}{a^2} - c^2}.$$

Thus, the correction to the frequency of the external force is of the order ε . Together with (6.25) we have the following nonlinear relation between the frequency ω of the external force and the response amplitude a of the corresponding forced periodic motion

$$\omega = 1 + \frac{3}{8}\varepsilon\alpha a^2 \pm \frac{1}{2}\varepsilon \sqrt{\frac{\hat{f}^2}{a^2} - c^2}. \quad (6.28)$$

Note that if both the force \hat{f} and the damping c are zero, then (6.28) reduces to the well-known formula (5.8) obtained previously for the free undamped Duffing's oscillator. If $\hat{f} > 0$, then there exists ω_c such that for $\omega > \omega_c$ the amplitude a is a multi-valued function of the frequency. However, if $c > 0$, then a is a multi-valued function of ω only in the range $\omega \in (\omega_c, 1 + \frac{3}{8}\varepsilon\alpha(\hat{f}/c)^2)$. Fig. 6.13 shows the amplitude versus frequency curves in these three different cases for $\alpha > 0$ (hardening

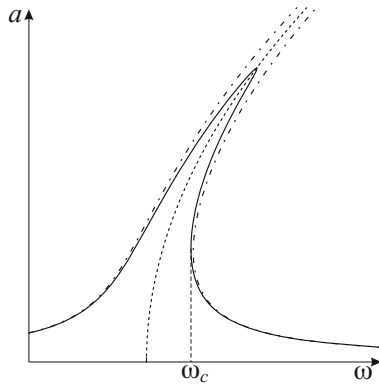

Fig. 6.13 Amplitude versus frequency curves of forced Duffing's oscillator: i) dashed line: $\hat{f} = c = 0$, ii) dotted and dashed line: $c = 0, \hat{f} > 0$, iii) bold line: both \hat{f} and c are positive

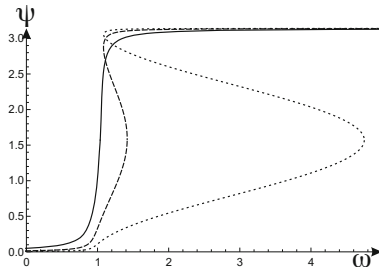

Fig. 6.14 Phase versus frequency curves of forced Duffing's oscillator

spring). Thus, for the fixed frequency ω and magnitude $\hat{f} > 0$ of the external force we may find in general either one or three steady-state amplitudes of forced vibrations. The phase of forced vibrations deviates also from that of the linear theory. Introducing the phase of forced vibrations as

$$\tan \psi = \frac{B}{A} = \frac{c}{\mp \sqrt{\frac{\hat{f}^2}{a^2} - c^2}},$$

we show the plot of ψ versus ω in Fig. 6.14 for $\epsilon = 0.1, \alpha = \hat{f} = 1$, and $c = 1$ (bold line), $c = 0.3$ (dashed line), $c = 0.1$ (dotted line).

Since there are several fixed points of system (6.27) we have to study their stability to select realizable solutions. As these fixed points correspond to the periodic solutions of (6.23), their stability means also the stability of the periodic solutions. For simplicity of our analysis, we consider the case $c = 0$. Denoting $\omega_1/\epsilon = k_1$, we write (6.27) in the form

$$\begin{aligned} A_{,\eta} &= -k_1 B + \frac{3}{8} \alpha B(A^2 + B^2), \\ B_{,\eta} &= k_1 A - \frac{3}{8} \alpha A(A^2 + B^2) + \frac{\hat{f}}{2}. \end{aligned} \tag{6.29}$$

For $\omega > \omega_c$ there are three roots of (6.28), a_1, a_2, a_3 , such that $a_1 > a_2 > a_3 > 0$. The corresponding fixed points S_1, S_2, S_3 have the coordinates given by

$$(A_1, B_1) = (a_1, 0), \quad (A_2, B_2) = (-a_2, 0), \quad (A_3, B_3) = (-a_3, 0).$$

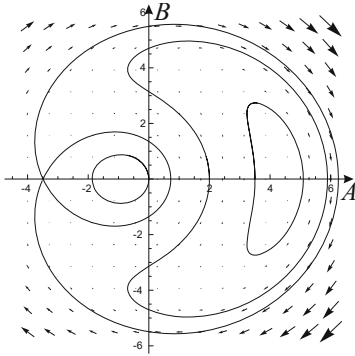

Fig. 6.15 Phase portrait of system (6.29)

To determine the stability of these fixed points we set $A = A_i + u, B = v$ and linearize (6.29) in u and v , giving

$$u_{,\eta} = \left(\frac{3}{8} \alpha A_i^2 - k_1\right)v, \quad v_{,\eta} = \left(-\frac{9}{8} \alpha A_i^2 + k_1\right)u.$$

Thus, if

$$D = \left(\frac{3}{8} \alpha A_i^2 - k_1\right)\left(\frac{9}{8} \alpha A_i^2 - k_1\right) > 0, \tag{6.30}$$

then the fixed point is a center, and if this same quantity is negative, the fixed point is a saddle point. For S_1 we have

$$k_1 = \frac{3}{8} \alpha a_1^2 - \frac{\hat{f}}{2a_1},$$

and condition (6.30) is satisfied for all ω so that the fixed point is a center. For S_2

$$k_1 = \frac{3}{8} \alpha a_2^2 + \frac{\hat{f}}{2a_2},$$

so in this case

$$D = -\frac{\hat{f}}{2a_2} \left(\frac{3}{4} \alpha a_2^2 - \frac{\hat{f}}{2a_2}\right) < 0,$$

and the fixed point is a saddle point. Finally, for S_3

$$D = -\frac{\hat{f}}{2a_3} \left(\frac{3}{4} \alpha a_3^2 - \frac{\hat{f}}{2a_3}\right) > 0,$$

so the fixed point is a center. It is interesting to note that, for S_2 and S_3 the sign of D is opposite to the sign of the derivative $\frac{d\omega}{da}$. The vector field and the phase portrait of (6.29) for $\omega > \omega_c$ are shown in Fig. 6.15. If some small damping is included ($c > 0$), then, by the continuity reasoning we expect that the centers would become stable foci attracting phase curves, while the saddle point remains unstable.

Imagine now that we can change the forcing frequency ω so slowly that the steady-state response amplitude a can follow it after a short transient period. Thus, if the forcing frequency is increased starting from zero, then the response amplitude follows first the stable upper branch OA up to point A. After point A no solution of this branch is possible, so the amplitude has to jump to the lower branch (this jump is marked by the vertical line AB) and then follows this stable branch down to point C. If the forcing frequency were now to reverse its course (again quasistatically), then the amplitude would go back along the lower branch CD, after which it jumps to the upper branch (the jump is marked by the vertical line DE), and finally follows this upper curve down to the end point O. This closed loop OABCDEO is called a hysteresis loop.

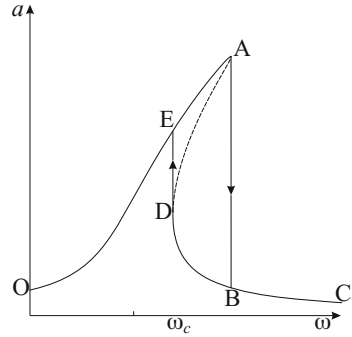

Fig. 6.16 Jump phenomenon and hysteresis

Note that the convergence of the approximate solution given by equations (6.25) and (6.27) to the exact solution of (6.23) as $\epsilon \rightarrow 0$ can be established for any finite time interval. We can also indirectly verify this result by comparing the solutions of (6.27) (presented by the dashed envelopes in Figs. 6.9-6.12) with the numerical solutions of (6.23). The agreement is excellent, although $\epsilon = 0.1$ is not quite small.

6.4 Forced Vibration of Self-excited Oscillator

Differential Equation of Motion. As we know from Section 5.3 a self-excited oscillator may have limit cycles as attractors of the phase curves. We want now to analyze the situation, when some external harmonic force acts on such the oscillator. As prototype we consider van der Pol’s oscillator subjected to a small harmonic excitation. Since we are interested in the primary 1:1 resonance, we order the amplitude of the excitation to be the same as the damping and non-linear term [36]. For this forced oscillator the displacement $x(t)$ satisfies the variational equation

$$\delta \int_{t_0}^{t_1} \left(\frac{1}{2} \dot{x}^2 - \frac{1}{2} x^2 + \epsilon \hat{f} \cos \omega t x \right) dt + \int_{t_0}^{t_1} \epsilon (1 - x^2) \dot{x} \delta x dt = 0, \tag{6.31}$$

where ϵ is a small parameter. This implies the following equation of motion

$$\ddot{x} + x - \epsilon (1 - x^2) \dot{x} = \epsilon \hat{f} \cos \omega t. \tag{6.32}$$

Equation (6.32) is called forced van der Pol’s equation. In the previous Section we have seen that, when a damped Duffing-type oscillator is driven by a harmonic force, the steady-state response will have the same frequency as the forcing frequency. If a self-excited oscillator is driven by some harmonic force, the steady state of

vibration may not exist at all and the forced response may include both the unforced limit cycle oscillation as well as a response at the forcing frequency. However, if the amplitude of the force is strong enough, and the frequency difference between the limit cycle oscillation and the harmonic force is small enough, then it may happen that the steady-state response exists and occurs only at the forcing frequency. In this case the forcing function is said to have entrained the limit cycle oscillator, and the system is said to be frequency-locked [36].

Numerical Solutions. Similar to the unforced van der Pol's equation, (6.32) does not permit exact analytical treatment. Therefore, to study the behavior of forced vibrations and illustrate the possibility of entrainment (or, equivalently, frequency locking) let us first do some numerical simulations.

We take $\varepsilon = 0.1$, $\hat{f} = 1.06$, and $\omega = 1.02$ and find the solution to (6.32) satisfying the initial conditions $x(0) = 1$, $\dot{x}(0) = 0$ by the numerical integration with *Mathematica*. The result shown in Fig. 6.17 exhibits the entrainment: a steady-state vibration with the forcing frequency is settled after a short transient period.

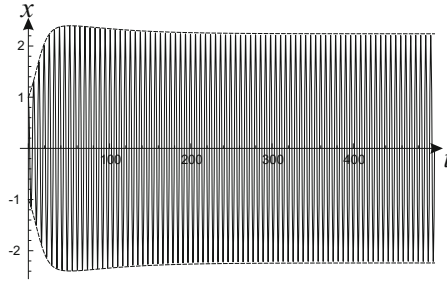

Fig. 6.17 Numerical solution of forced van der Pol's oscillator for $\varepsilon = 0.1$, $\hat{f} = 1.06$, and $\omega = 1.02$

If we increase a little bit the forcing frequency while keeping all other parameters and initial data, the response may change drastically. For example, the solution for $\omega = 1.05$ shown in Fig. 6.18 exhibits a beating behavior typical for the oscillation with two nearly equal frequencies. Thus, in this case entrainment does not occur, and the system is unlocked.

In the next paragraph we will use the variational-asymptotic method to establish the law of slow change of response amplitude as function of the forcing parameters and to predict the entrainment effect for small ε . The outcome of this asymptotic analysis is shown in Figs. 6.17 and 6.18: the dashed envelopes are computed according to the obtained equations of slow change. The agreement is good although $\varepsilon = 0.1$ is not quite small.

Variational-Asymptotic Method. Let us introduce the stretched angular time $\tau = \omega t$ explicitly in the variational equation (6.31). Since $\dot{x} = \omega x'$, where prime denotes the derivative with respect to τ , equation (6.31) becomes

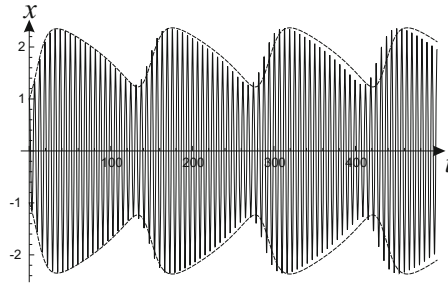

Fig. 6.18 Numerical solution of forced van der Pol's oscillator for $\varepsilon = 0.1$, $\hat{f} = 1.06$, and $\omega = 1.05$

$$\delta \int_{\tau_0}^{\tau_0+2\pi} \left(\frac{1}{2} \omega^2 x'^2 - \frac{1}{2} x^2 + \varepsilon \hat{f} \cos \tau x \right) d\tau + \int_{\tau_0}^{\tau_0+2\pi} \varepsilon (1 - x^2) \omega x' \delta x d\tau = 0, \quad (6.33)$$

where $\tau_1 = \tau_0 + 2\pi$ and τ_0 is an *arbitrary* time instant. For short we set $\tau_0 = 0$.

At the first step of the variational-asymptotic procedure we neglect all terms containing ε to get

$$\delta \int_0^{2\pi} \left(\frac{1}{2} \omega^2 x'^2 - \frac{1}{2} x^2 \right) d\tau = 0.$$

The 2π -periodic extremal of this variational problem is

$$x_0(\tau) = A \cos \tau + B \sin \tau.$$

The coefficients A and B in this solution are still unknown.

For $\varepsilon \neq 0$ the coefficients A and B are becoming dependent on time and the forcing frequency deviates from 1. Therefore we introduce the slow time $\eta = \varepsilon \tau$ and search for the corrections to the extremal and to the frequency at the second step in the form

$$x(\tau) = A(\eta) \cos \tau + B(\eta) \sin \tau + x_1(\tau, \eta), \quad \omega = 1 + \omega_1, \quad (6.34)$$

where $x_1(\tau, \eta)$ is a 2π -periodic function with respect to τ and is much smaller than $x_0(\tau, \eta) = A(\eta) \cos \tau + B(\eta) \sin \tau$ in the asymptotic sense, and ω_1 is assumed to be much smaller than 1. The second equation of (6.34) means that we are restricting to the case where the forcing frequency is nearly equal to the unforced limit cycle frequency, which is called a 1:1 resonance. Note that the time derivative of $x(\tau)$ is equal to

$$x' = x_{0,\tau} + \varepsilon x_{0,\eta} + x_{1,\tau} + \varepsilon x_{1,\eta}.$$

Here the comma in index means the partial derivative. We substitute (6.34) into (6.33) and keep the asymptotically principal terms containing x_1 and the principal cross terms between x_0 and x_1 . The variational equation becomes

$$\delta \int_0^{2\pi} \left[\frac{1}{2} x_{1,\tau}^2 + \underline{x_{0,\tau} x'_1} + \underline{\varepsilon x_{0,\eta} x'_1} + 2\omega_1 x_{0,\tau} x'_1 - \frac{1}{2} x_1^2 - \underline{x_0 x_1} + \varepsilon \hat{f} \cos \tau x_1 + \varepsilon (1 - x_0^2) x_{0,\tau} x_1 \right] d\tau = 0.$$

Next, integrating the second, third, and fourth terms by parts using the periodicity of x_1 , we get from the underlined terms $-2\varepsilon x_{0,\eta} \tau x_1$. Finally, reducing the products of sine and cosine in the last term to the sum of harmonic functions,² we transform the variational equation to

$$\delta \int_0^{2\pi} \left[\frac{1}{2} x_{1,\tau}^2 - \frac{1}{2} x_1^2 + (\dots) \sin \tau x_1 + (\dots) \cos \tau x_1 + \text{nonresonant terms} \right] d\tau = 0.$$

The consistency condition requires removal of the resonant terms that leads to

$$\begin{aligned} 2A_{,\eta} &= -2 \frac{\omega_1}{\varepsilon} B + A - \frac{A}{4} (A^2 + B^2), \\ 2B_{,\eta} &= 2 \frac{\omega_1}{\varepsilon} A + B - \frac{B}{4} (A^2 + B^2) + \hat{f}. \end{aligned}$$

We see that the correction to the frequency must be of the order ε . Denoting ω_1 by $\omega_1 = k_1 \varepsilon$, we rewrite this system of equations in the form

$$\begin{aligned} 2A_{,\eta} &= -2k_1 B + A - \frac{A}{4} (A^2 + B^2), \\ 2B_{,\eta} &= 2k_1 A + B - \frac{B}{4} (A^2 + B^2) + \hat{f}. \end{aligned} \tag{6.35}$$

System (6.35) can be simplified by using polar coordinates a and ψ in the phase plane

$$A = a \cos \psi, \quad B = a \sin \psi. \tag{6.36}$$

In terms of a and ψ we can present x_0 as

$$x_0(\tau, \eta) = a(\eta) \cos(\tau - \psi(\eta)).$$

Thus, $a(\eta)$ has the meaning of amplitude of vibration, while $\psi(\eta)$ can be interpreted as the phase; both are slowly changing functions of time. Substituting (6.36) into (6.35) gives

$$\begin{aligned} a_{,\eta} &= \frac{a}{8} (4 - a^2) + \frac{\hat{f}}{2} \sin \psi, \\ \psi_{,\eta} &= k_1 + \frac{\hat{f}}{2a} \cos \psi. \end{aligned} \tag{6.37}$$

² This can be done quite nicely in *Mathematica* with the help of TrigReduce command. Another way is to use the complex representations of sine and cosine, then multiply everything out and finally collect terms.

When $\hat{f} = 0$, equations (6.37) reduce to the well-known equations (5.32) derived for the self-excited vibrations of val der Pol's oscillator. We seek fixed points of the slow flow (6.37) which correspond to locked periodic motions of (6.32). Setting $a, \eta = \psi, \dot{\eta} = 0$, solving for $\sin \psi$ and $\cos \psi$ and using the identity $\sin^2 + \cos^2 = 1$, we obtain

$$a^2 \left(1 - \frac{a^2}{4} \right)^2 + 4k_1^2 a^2 = \hat{f}^2.$$

Expanding this equation and denoting $p = a^2$, we have

$$\frac{p^3}{16} - \frac{p^2}{2} + (4k_1^2 + 1)p - \hat{f}^2 = 0. \tag{6.38}$$

This cubic equation in p , in view of its 3 sign changes, has either 3 positive roots, or one positive and two complex conjugate roots. The transition between these two cases occurs when there is a double root, which is equivalent to the condition that the derivative of the left-hand side expression vanishes

$$\frac{3p^2}{16} - p + 1 + 4k_1^2 = 0. \tag{6.39}$$

Eliminating p in the last two equations, we obtain

$$\frac{\hat{f}^4}{16} - \frac{\hat{f}^2}{27}(1 + 36k_1^2) + \frac{16}{27}k_1^2(1 + 4k_1^2)^2 = 0.$$

This equation gives two curves meeting at a cusp in the (k_1, \hat{f}) -plane. As one of these curves is traversed quasistatically, a saddle-node bifurcation occurs. At the cusp we have a triple root leading to a further degeneracy. The condition for this is

$$\frac{3p}{8} - 1 = 0 \Rightarrow p = \frac{8}{3}.$$

With this value $p = 8/3$ we can easily find the location of the cusp at

$$k_1 = \frac{1}{\sqrt{12}} \approx 0.288, \quad \hat{f} = \sqrt{\frac{32}{27}} \approx 1.088.$$

The square of amplitude versus frequency curves in terms of $p = a^2$ and k_1 are shown in Fig. 6.19 for different forcing amplitudes \hat{f} . For $\hat{f} = 0$, the curves degenerate into the k_1 -axis and the point $(0, 4)$ corresponding to the limit cycle unforced vibration. As \hat{f} increases, the curves first consist of two branches- a branch running near the k_1 -axis and a closed curve surrounding the point $(0, 4)$. When $\hat{f} = \frac{4}{3\sqrt{3}}$, the

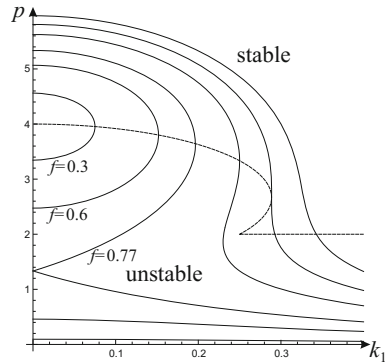

Fig. 6.19 Response-frequency curves

two branches coalesce, and the resultant curve has a double point at $(0, 4/3)$. As \hat{f} increases beyond this critical value, the response curves are open curves. However, p is still not single-valued function of k_1 until \hat{f} exceeds the second critical value $\hat{f} = \sqrt{32}/\sqrt{27}$. Beyond this critical value the response curves are single-valued for all k_1 .

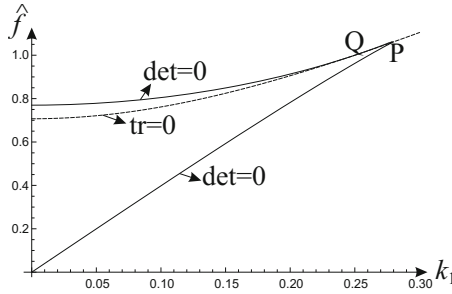

Fig. 6.20 Curves given by: i) $\det \mathbf{M} = 0$ (bold lines), ii) $\text{tr} \mathbf{M} = 0$ (dashed line)

Since several fixed points of (6.37) are present, we must investigate their stability. Let (a_0, ψ_0) be a fixed point of (6.37). We search for the solutions of (6.37) in the form

$$a = a_0 + u, \quad \psi = \psi_0 + v,$$

where u and v are small perturbations. Substituting this into (6.37) and linearizing in u and v gives

$$\begin{aligned} u_{,\eta} &= \frac{u}{2} - \frac{3}{8} a_0^2 u + \frac{\hat{f}}{2} \cos \psi_0 v, \\ v_{,\eta} &= -\frac{\hat{f}}{2 a_0^2} \cos \psi_0 u - \frac{\hat{f}}{2 a_0} \sin \psi_0 v. \end{aligned}$$

This system may be simplified by using the following expressions valid at the fixed point

$$\frac{\hat{f}}{2} \sin \psi_0 = -\frac{a_0}{2} + \frac{a_0^3}{8}, \quad \frac{\hat{f}}{2} \cos \psi_0 = -k_1 a_0.$$

Thus, the stability is determined by the eigenvalues of the following matrix \mathbf{M}

$$\mathbf{M} = \begin{pmatrix} \frac{1}{2} - \frac{3}{8} a_0^2 & -k_1 a_0 \\ \frac{k_1}{a_0} & \frac{1}{2} - \frac{1}{8} a_0^2 \end{pmatrix}.$$

Its eigenvalues λ are the roots of the characteristic equation

$$\lambda^2 - \text{tr} \mathbf{M} \lambda + \det \mathbf{M} = 0,$$

where

$$\begin{aligned} \text{tr}\mathbf{M} &= 1 - \frac{a_0^2}{2} = 1 - \frac{p}{2}, \\ \det\mathbf{M} &= \left(-\frac{1}{2} + \frac{3}{8}a_0^2\right)\left(-\frac{1}{2} + \frac{1}{8}a_0^2\right) + k_1^2 = \frac{1}{4}\left(\frac{3p^2}{16} - p + 1 + 4k_1^2\right). \end{aligned}$$

For stability, the eigenvalues of \mathbf{M} must have negative real parts. This puts on the trace and determinant of \mathbf{M} the following conditions

$$\text{tr}\mathbf{M} = 1 - \frac{p}{2} < 0, \quad \det\mathbf{M} = \frac{1}{4}\left(\frac{3p^2}{16} - p + 1 + 4k_1^2\right) > 0.$$

The curves corresponding to $\det\mathbf{M} = 0$ (bold lines) and $\text{tr}\mathbf{M} = 0$ (dashed line) in the (k_1, \hat{f}) -plane are shown in Fig. 6.20.

Comparing the last condition with equation (6.39), we see that $\det\mathbf{M}$ vanishes on the curve (6.39) along which there are saddle-node bifurcations. This is a typical feature of nonlinear vibrations, namely that a change in stability is accompanied by a bifurcation. The first condition on the trace of \mathbf{M} requires that $p > 2$ for the stability. Substitute $p = 2$ in (6.38), we obtain

$$\hat{f}^2 = \frac{1}{2} + 8k_1^2. \tag{6.40}$$

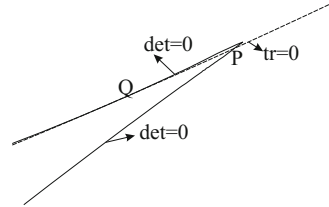

Fig. 6.21 Bifurcation curves

Hopf bifurcations occur along the curve represented by (6.40), provided $\det\mathbf{M} > 0$. This curve intersects the lower curve of saddle-node bifurcations obtained from (6.39) at point P, and touches the upper curve of saddle-node bifurcations at point Q in the (k_1, \hat{f}) -plane with the coordinates (see Fig. 6.21)

$$P : k_1 = \frac{\sqrt{5}}{8}, \quad \hat{f} = \frac{3}{\sqrt{8}}, \quad Q : k_1 = \frac{1}{4}, \quad \hat{f} = \frac{5}{\sqrt{27}}.$$

Thus, the stability analysis predicts that the forced van der Pol oscillator exhibits stable entrainment solutions everywhere in the first quadrant of the (k_1, \hat{f}) -plane except in that region bounded by i) the lower curve of saddle node bifurcations corresponding to $\det\mathbf{M} = 0$ from the origin to point P, ii) the curve of Hopf bifurcation corresponding to $\text{tr}\mathbf{M} = 0$ from point P to infinity, and iii) the k_1 -axis. In terms of p and k_1 the boundary between stable and unstable solutions is marked by the dashed lines shown in Fig. 6.19. This means that for a given detuning k_1 there is a minimum value of forcing \hat{f} required in order for entrainment to occur. Note that, since k_1 always appears in the form k_1^2 in the equations of the bifurcation and stability curves, the above conclusions are independent of whether we are above or below the 1:1 resonance. The discussions about other resonances can be found in [36].

The entrainment is widely used in engineering to synchronize nonlinear oscillators (for instance clocks). Another positive and pleasant spillover effect

of entrainment often takes place when an orchestra is playing music. Various string- and wind-instruments are self-excited oscillators, which may experience extra excitations through the sound waves generated by other players of the orchestra. When one of these musical instruments produces a tone which is not quite clean, it may be entrained by the remaining instruments so that only one tone will be heard, provided the forcing amplitude of the sound waves is strong enough.

6.5 Exercises

EXERCISE 6.1. A point-mass m is constrained to move in the (x,y) -plane and is restrained by two linear springs of equal stiffness k and equal unstretched length l . The anchor points of the springs are located on the x -axis at $x = -b$ and $x = b$ (see Fig. 6.22). Study the stability of the motion along the x -axis, $x = a \cos \omega_0 t$, $y = 0$ under the assumption that $a \ll b$.

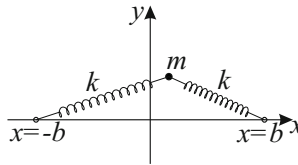

Fig. 6.22 Point-mass in (x,y) -plane

Solution. Let $q = (x,y)$. To derive the equations of motion we write down the Lagrange function

$$L(q, \dot{q}) = K(\dot{q}) - U(q),$$

where the kinetic energy is

$$K(\dot{q}) = \frac{1}{2}m(\dot{x}^2 + \dot{y}^2),$$

and the potential energy of the springs is

$$U(q) = \frac{1}{2}k(\sqrt{(x+b)^2 + y^2} - l)^2 + \frac{1}{2}k(\sqrt{(b-x)^2 + y^2} - l)^2.$$

From Lagrange's equations

$$\frac{d}{dt} \frac{\partial L}{\partial \dot{q}_j} - \frac{\partial L}{\partial q_j} = 0, \quad j = 1, 2,$$

follow

$$m\ddot{x} = f_x, \quad m\ddot{y} = f_y,$$

where

$$f_x = -\frac{\partial U}{\partial x} = -\frac{k(\sqrt{(x+b)^2+y^2}-l)(x+b)}{\sqrt{(x+b)^2+y^2}} + \frac{k(\sqrt{(b-x)^2+y^2}-l)(b-x)}{\sqrt{(b-x)^2+y^2}},$$

$$f_y = -\frac{\partial U}{\partial y} = -\frac{k(\sqrt{(x+b)^2+y^2}-l)y}{\sqrt{(x+b)^2+y^2}} - \frac{k(\sqrt{(b-x)^2+y^2}-l)y}{\sqrt{(b-x)^2+y^2}}.$$

One possible particular solution of these equations is obtained when $y = 0$. In this case the second equation is identically satisfied, while the first equation reduces to

$$m\ddot{x} + 2kx = 0,$$

yielding

$$x_0 = a \cos(\omega_0 t - \phi), \quad \omega_0 = \sqrt{2k/m},$$

where the initial phase ϕ can be set equal to zero. To study the stability of this motion along the x -axis, $q_0(t) = (a \cos \omega_0 t, 0)$, we consider the neighboring solutions in the form

$$x = a \cos \omega_0 t + u, \quad y = v,$$

where u and v are assumed to be small. Substituting these formulas into the equations of motion, expanding the right-hand sides in the Taylor series in terms of u and v , and taking into account the equations for $q_0(t)$, we obtain

$$m\ddot{u} = \left. \frac{\partial f_x}{\partial x} \right|_{q_0} u + \left. \frac{\partial f_x}{\partial y} \right|_{q_0} v,$$

$$m\ddot{v} = \left. \frac{\partial f_y}{\partial x} \right|_{q_0} u + \left. \frac{\partial f_y}{\partial y} \right|_{q_0} v.$$

Computing the partial derivatives of f_x and f_y and evaluating them at $q_0 = (x_0, 0)$, it is easy to check that

$$\left. \frac{\partial f_x}{\partial x} \right|_{q_0} = -2k, \quad \left. \frac{\partial f_x}{\partial y} \right|_{q_0} = 0, \quad \left. \frac{\partial f_y}{\partial x} \right|_{q_0} = 0,$$

$$\left. \frac{\partial f_y}{\partial y} \right|_{q_0} = -2k \frac{1 - \lambda - \alpha^2 \cos^2 \omega_0 t}{1 - \alpha^2 \cos^2 \omega_0 t},$$

where

$$\lambda = \frac{l}{b}, \quad \alpha = \frac{a}{b}.$$

The equation for u turns out to be the equation for a harmonic oscillator, $m\ddot{u} + 2ku = 0$, and cannot produce instability. The equation for v is

$$m\ddot{v} + 2k \frac{1 - \lambda - \alpha^2 \cos^2 \omega_0 t}{1 - \alpha^2 \cos^2 \omega_0 t} v = 0.$$

Expanding the second term for small α and setting $\tau = 2\omega_0 t$, we obtain

$$\frac{d^2 v}{d\tau^2} + \left(\frac{2 - 2\lambda - \lambda\alpha^2}{8} - \frac{\lambda\alpha^2}{8} \cos \tau \right) v = 0,$$

which is the Mathieu's equation. Thus, the stability chart of Mathieu's equation can be used to investigate the stability of this motion.

EXERCISE 6.2. The support of a pendulum considered in example 6.1 moves in accordance with the equation $x = a_0 \cos \omega t$, where $a_0 = 0.1l$. How large must the frequency ω be to stabilize the vertical position $\varphi = \pi$.

Solution. The equation of motion of this pendulum is

$$\ddot{\varphi} + \frac{1}{l}(g + a_0\omega^2 \cos \omega t) \sin \varphi = 0.$$

To analyze the stability of the vertical position, it is enough to linearize this equation about $\varphi = \pi$. Let

$$\varphi = \pi + x,$$

where $x \ll 1$ is a small perturbation. The linearization with respect to x leads to

$$\ddot{x} - \frac{1}{l}(g + a_0\omega^2 \cos \omega t)x = 0.$$

This equation can be transformed to Mathieu's equation

$$\ddot{x} + (\mu + \varepsilon \cos t)x = 0,$$

with $\mu = -(\omega_0/\omega)^2$, $\varepsilon = -a_0/l$, and $\omega_0 = \sqrt{g/l}$, if the time is replaced by the dimensionless time ωt . Thus, we can use the stability chart of Mathieu's equation to study the stability of the vertical position. Since μ is negative, we use the first transition curve lying in the left half-plane of the (μ, ε) -plane described by

$$\mu = -\varepsilon^2/2$$

to find the condition for stability. As $\varepsilon = -0.1$, the vertical position is stable if

$$(\omega_0/\omega)^2 < 0.1^2/2 \quad \Rightarrow \quad \omega > \frac{\sqrt{2}}{0.1}\omega_0.$$

Thus, the vertical position will be stabilized if the frequency of the vibration of the support is at least 14.14 times larger than the eigenfrequency of the pendulum.

EXERCISE 6.3. Apply the variational-asymptotic method to find the asymptotes of the transition curves of Mathieu's equation emanating from the point $\mu = 1$.

Solution. The first step of the variational-asymptotic method yields

$$x(t) = x_0(t) = A \cos t + B \sin t.$$

At the second step the obtained functional for x_1 near $\mu = 1$, as seen from (6.12), does not contain additional resonant terms except the third and the fourth. Thus, $A_{,\eta} = B_{,\eta} = 0$ at this step, and the extremal of (6.12) is easily found to be

$$x_1(t) = \varepsilon \left(-\frac{1}{2}A + \frac{1}{6}A \cos 2t + \frac{1}{6}B \sin 2t \right).$$

At the third step we look for $x(t)$ and μ in the form

$$x(t) = x_0(t, \eta) + x_1(t, \eta) + x_2(t, \eta), \quad \mu = 1 + \mu_2,$$

where $\eta = \varepsilon t$ is the slow time and $x_0(t, \eta)$ and $x_1(t, \eta)$ are given by the above formulas with A and B being now functions of the slow time. Function $x_2(t, \eta)$ and μ_2 are assumed to be much smaller than $x_1(\eta, t)$ and 1, respectively. Besides, $x_2(t, \eta)$ is 2π -periodic with respect to t . The time derivative of $x(t)$ becomes

$$\dot{x} = x_{0,t} + \varepsilon x_{0,\eta} + x_{1,t} + \varepsilon x_{1,\eta} + x_{2,t} + \varepsilon x_{2,\eta}.$$

We substitute x and \dot{x} into (6.9) and keep the asymptotically principal terms containing x_2 and the principal cross terms. The functional becomes

$$\begin{aligned} I_2[x_2(t)] = & \int_0^{2\pi} \left[\frac{1}{2}x_{2,t}^2 + \underline{x_{0,t}x_{2,t}} + \varepsilon x_{0,\eta}x_{2,t} + \underline{\underline{x_{1,t}x_{2,t}}} + \varepsilon x_{1,\eta}x_{2,t} \right. \\ & \left. - \frac{1}{2}x_2^2 - \underline{x_0x_2} - \mu_2x_0x_2 - \underline{x_1x_2} - \underline{\underline{\varepsilon \cos t x_0x_2}} - \varepsilon \cos t x_1x_2 \right] dt. \end{aligned}$$

Integrating the cross terms containing $x_{2,t}$ by parts and taking into account the periodicity of x_2 in t and the equations for x_0 and x_1 , we see that the underlined and doubly underlined terms are canceled out. Among the remaining terms only $\varepsilon x_{0,\eta}x_{2,t}$, $-\mu_2x_0x_2$ and the last term contributes to the resonant terms. The products $\cos t \cos 2t$ and $\cos t \sin 2t$ in the last term can be transformed into the sum of harmonic functions as follows

$$\cos t \cos 2t = \frac{1}{2}(\cos t + \cos 3t), \quad \cos t \sin 2t = \frac{1}{2}(\sin t + \sin 3t).$$

Requiring that the resonant terms must vanish, we obtain for $A(\eta)$ and $B(\eta)$ the equations

$$-\varepsilon B_{,\eta} + \frac{5}{12}\varepsilon^2 A - \mu_2 A = 0, \quad \varepsilon A_{,\eta} - \frac{1}{12}\varepsilon^2 B - \mu_2 B = 0.$$

From these equations we obtain the resulting equation for A (and the similar for B)

$$\varepsilon^2 A_{,\eta\eta} + \left(\mu_2 - \frac{5}{12}\varepsilon^2 \right) \left(\mu_2 + \frac{1}{12}\varepsilon^2 \right) A = 0,$$

which shows that the stability (or instability) is determined by the sign of $(\mu_2 - \frac{5}{12}\varepsilon^2)(\mu_2 + \frac{1}{12}\varepsilon^2)$. Thus, the transition occurs at $\mu_2 = -\frac{1}{12}\varepsilon^2$ and at $\mu_2 = \frac{5}{12}\varepsilon^2$, or, in terms of μ , at

$$\mu = 1 - \frac{1}{12}\varepsilon^2 \quad \text{and at} \quad \mu = 1 + \frac{5}{12}\varepsilon^2,$$

which are in full agreement with the asymptotic formulas obtained from the vanishing Hill's determinants.

EXERCISE 6.4. Consider the damped Mathieu's equation

$$\ddot{x} + \varepsilon c\dot{x} + (\mu + \varepsilon \cos t)x = 0,$$

with ε being a small parameter. Apply the variational-asymptotic method to find the asymptotes of the transition curves near the point $\mu = 1/4$.

Solution. The variational equation corresponding to this damped Mathieu's equation reads

$$\delta \int_0^T \left[\frac{1}{2}\dot{x}^2 - \frac{1}{2}(\mu + \varepsilon \cos t)x^2 \right] dt - \int_0^T \varepsilon c\dot{x}\delta x dt = 0.$$

At the first step of the variational asymptotic procedure we put simply $\varepsilon = 0$ to get from this equation

$$\delta \int_0^T \left(\frac{1}{2}\dot{x}^2 - \frac{1}{2}\mu x^2 \right) dt = 0.$$

The periodic extremal (with the period $T = 2\pi/\sqrt{\mu}$) reads

$$x_0(t) = A \cos \sqrt{\mu}t + B \sin \sqrt{\mu}t.$$

Let $\mu = 1/4 + \varepsilon\mu_1$. Taking into account that the coefficients A and B are becoming slightly dependent on time for $\varepsilon \neq 0$, we introduce the slow time $\eta = \varepsilon t$ and seek the corrections to the extremal at the second step in the two-timing fashion

$$x(t) = A(\eta) \cos \frac{1}{2}t + B(\eta) \sin \frac{1}{2}t + x_1(t, \eta),$$

where $x_1(t, \eta)$ is a periodic function of the period T with respect to t and is much smaller than $x_0(t, \eta)$ in the asymptotic sense. Substituting this Ansatz into the variational equation and proceeding similarly as in Section 6.1, we obtain for A and B the following equations

$$A_{,\eta} = -\frac{c}{2}A + \left(\mu_1 - \frac{1}{2}\right)B, \quad B_{,\eta} = -\frac{c}{2}B - \left(\mu_1 + \frac{1}{2}\right)A.$$

Thus, the last term in the variational equation contributes additional resonant terms. The last equations are linear equations with constant coefficients which may be solved by assuming a solution in the form $A(\eta) = A_0 \exp(\lambda \eta)$, $B(\eta) = B_0 \exp(\lambda \eta)$. Nontrivial solutions exist if the following determinant vanishes

$$\begin{vmatrix} -\frac{c}{2} - \lambda & -\frac{1}{2} + \mu_1 \\ -\frac{1}{2} - \mu_1 & -\frac{c}{2} - \lambda \end{vmatrix} = 0.$$

Thus,

$$\lambda = -\frac{c}{2} \pm \sqrt{-\mu_1^2 + \frac{1}{4}}.$$

At the transition curve $\lambda = 0$, so

$$\mu_1 = \pm \frac{\sqrt{1 - c^2}}{2}.$$

This gives the following expressions for the transition curves near $\mu = 1/4$:

$$\mu = \frac{1}{4} \pm \varepsilon \frac{\sqrt{1 - c^2}}{2}.$$

This formula predicts that for a given value of c there is a minimum value of ε which is required for instability to occur. The tongue, which, for $c = 0$, emanates from the μ -axis, becomes detached from the μ -axis for $c > 0$.

EXERCISE 6.5. Non-linear parametric resonance. Consider the following equation

$$\ddot{x} + \omega^2 x + \varepsilon \cos t x^3 = 0,$$

with ε being a small parameter. Apply the variational-asymptotic method to study the behavior of solutions near the frequency $\omega_0 = 1/2$.

Solution. The solution of the above equation is the extremal of the following action functional

$$\int_0^T \left[\frac{1}{2} \dot{x}^2 - \frac{1}{2} \omega^2 x^2 - \frac{1}{4} \varepsilon \cos t x^4 \right] dt.$$

It is convenient to change to the new variable $\tau = \omega_0 t$, in terms of which the action functional takes the form

$$I[x(\tau)] = \int_0^{2\pi} \left[\frac{1}{2} \omega_0^2 \dot{x}^2 - \frac{1}{2} \omega^2 x^2 - \frac{1}{4} \varepsilon \cos \frac{\tau}{\omega_0} x^4 \right] d\tau.$$

At the first step of the variational-asymptotic method we put $\varepsilon = 0$ in this functional to obtain $\omega = \omega_0 = 1/2$ and

$$x(\tau) = x_0(\tau) = A \cos \tau + B \sin \tau.$$

At the second step we look for $x(\tau)$ and ω in the form

$$x(\tau) = x_0(\tau, \eta) + x_1(\tau, \eta), \quad \omega = \omega_0 + \omega_1,$$

where $\eta = \varepsilon \tau$ and $x_0(\tau, \eta)$ is given by the previous equation with A and B being now the functions of η . We assume also that x_1 is 2π -periodic in τ . Note that the derivative of x equals

$$x' = x_{0,\tau} + \varepsilon x_{0,\eta} + x_{1,\tau} + \varepsilon x_{1,\eta}.$$

We substitute these formulas into the action functional and keep the asymptotically principal terms containing x_1 and the principal cross terms between x_0 and x_1 . The functional becomes

$$I_1[x_1(\tau)] = \int_0^{2\pi} \left[\frac{1}{2} \omega_0^2 x_{1,\tau}^2 + \underline{\omega_0^2 x_{0,\tau} x_{1,\tau}} + \omega_0^2 \varepsilon x_{0,\eta} x_{1,\tau} - \frac{1}{2} \omega_0^2 x_1^2 - \underline{\omega_0^2 x_0 x_1} - 2\omega_0 \omega_1 x_0 x_1 - \varepsilon \cos \frac{\tau}{\omega_0} x_0^3 x_1 \right] d\tau.$$

Integrating the cross terms containing $x_{1,\tau}$ by parts and taking into account the 2π -periodicity of x_1 in τ and the equations for x_0 , we see that the underlined terms are canceled out. Besides, with the TrigReduce command in *Mathematica* one can show that the last term contributes two resonant terms, namely, $-\frac{1}{2}\varepsilon A^3 \cos \tau x_1$ and $\frac{1}{2}\varepsilon B^3 \sin \tau x_1$. Requiring that the resonant terms must vanish, we obtain for $A(\eta)$ and $B(\eta)$ the equations

$$\frac{1}{4}\varepsilon A_{,\eta} - \omega_1 B + \frac{1}{2}\varepsilon B^3 = 0, \quad \frac{1}{4}\varepsilon B_{,\eta} + \omega_1 A + \frac{1}{2}\varepsilon A^3 = 0.$$

Dividing these equations by $\varepsilon/4$ and introducing $k_1 = 2\omega_1/\varepsilon$, we rewrite them in the form

$$A_{,\eta} - 2k_1 B + 2B^3 = 0, \quad B_{,\eta} + 2k_1 A + 2A^3 = 0.$$

These equations have one fixed point $(0,0)$ which is a stable center, and two other fixed points

$$(0, \sqrt{k_1}), \quad (0, -\sqrt{k_1}), \quad (6.41)$$

provided $k_1 > 0$, or

$$(\sqrt{-k_1}, 0), \quad (-\sqrt{-k_1}, 0), \quad (6.42)$$

provided $k_1 < 0$. It is easy to check that the fixed points lying on the B - or A -axis are saddle points.

EXERCISE 6.6. Solve the slow flow system (6.26) numerically for $\varepsilon = 0.1$, $c = 0$, $\alpha = \hat{f} = 1$ and for two detuning values $k_1 = 0$ and $k_1 = -0.125$, with the initial conditions $A(0) = 1$ and $B(0) = 0$. Plot the curves $a(\tau) = \sqrt{A^2 + B^2}$ together with the numerical solutions shown in Figs. 6.8 and 6.9.

Solution. Remembering that the slow time $\eta = \varepsilon t$, we rewrite equations (6.26) for $c = 0$ in terms of the real time

$$A_{,t} = -\omega_1 B + \frac{3}{8}\alpha\varepsilon B(A^2 + B^2),$$

$$B_{,t} = \omega_1 A - \frac{3}{8}\alpha\varepsilon A(A^2 + B^2) + \varepsilon \frac{\hat{f}}{2}.$$

This system of nonlinear first-order differential equations can be integrated numerically by using the standard command `NDSolve` in *Mathematica*. Based on this numerical integration function $a(t) = \sqrt{A^2 + B^2}$ can then be plotted. For $\varepsilon = 0.1$, $\alpha = \hat{f} = 1$ and $\omega_1 = 0$ the commands are

```
sol = NDSolve[ { a'[t] ==  $\frac{3}{8} \varepsilon b[t] (a[t]^2 + b[t]^2)$ ,
               b'[t] ==  $-\frac{3}{8} \varepsilon a[t] (a[t]^2 + b[t]^2) + \varepsilon f / 2$ ,
               a[0] == 1, b[0] == 0 }, {a, b}, {t, 200} ]
Plot[ { Evaluate[  $\sqrt{(a[t] /. sol)^2 + (b[t] /. sol)^2}$  ],
       Evaluate[  $-\sqrt{(a[t] /. sol)^2 + (b[t] /. sol)^2}$  ] ],
      {t, 0, 200}, PlotRange -> All, PlotStyle -> Black ]
```

Here, in accordance with the recommendation of *Mathematica*, the lower case letters for functions are used everywhere. The plot of $a(t) = \sqrt{A^2 + B^2}$ based on this numerical integration is shown together with the solution of the forced Duffing's equation in Fig. 6.9.

The case $\omega = 0.9875$ corresponding to the detuning value $k_1 = -0.125$ can be studied in a similar manner. The plot of $a(t) = \sqrt{A^2 + B^2}$ based on the numerical integration is shown together with the solution of the forced Duffing's equation in Fig. 6.10. One can see that the solution is purely periodic which corresponds to the constant amplitude $a = \sqrt{A^2 + B^2}$.

EXERCISE 6.7. Find the steady-state amplitude versus frequency curve of the forced Duffing's equation with the softening spring ($\alpha < 0$). Discuss the jump phenomenon and the hysteresis loop.

Solution. The plot of the amplitude-frequency curves according to the formula

$$\omega = 1 + \frac{3}{8} \varepsilon \alpha a^2 \pm \frac{1}{2} \varepsilon \sqrt{\frac{\hat{f}^2}{a^2} - c^2}$$

is shown in Fig. 6.23 for $\varepsilon = 0.1$, $\alpha = -1$, $\hat{f} = 1$, and $c = 0.3$. We see that, for negative α the amplitude-frequency curves are bent to the left. There exists $\omega_c < 1$ such that for $\omega < \omega_c$ the amplitude a is a multi-valued function of the frequency. However, if $c > 0$, then a is a multi-valued function of ω only in the range $\omega \in (1 + \frac{3}{8} \varepsilon \alpha (\hat{f}/c)^2, \omega_c)$. Imagine now that we can change the forcing frequency ω so slowly that the steady-state response amplitude a can follow it after a short transient period. Thus, if the forcing frequency is decreased starting from some value larger than ω_c , then the response amplitude follows first the stable upper branch OA up to point A (it can be shown that the middle branch between points A and D contains unstable solutions). After point A no solution of the upper branch is possible, so the amplitude has to jump to the lower branch (this jump is marked by the vertical line

AB) and then follows this stable branch down to point C. If the forcing frequency were now to reverse its course (again quasistatically), then the amplitude would go back along the lower branch CD, after which it jumps to the upper branch (the jump is marked by the vertical line DE), and finally follows this upper curve down to the end point O. This closed loop OABCDEO is called a hysteresis loop for the Duffing's oscillator with the softening spring.

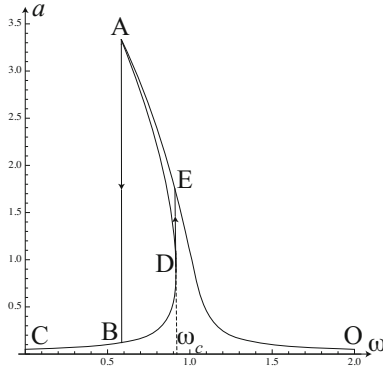

Fig. 6.23 Amplitude-frequency curve and hysteresis

EXERCISE 6.8. Consider the forced oscillator with the quadratic damping described by the equation

$$\ddot{x} + x + \varepsilon c \dot{x} |\dot{x}| = \varepsilon \hat{f} \cos \omega t,$$

where ε is small. Apply the variational-asymptotic method to find the amplitude versus frequency curve near the 1:1 resonant frequency.

Solution. The above equation can be derived from the variational equation

$$\delta \int_0^T \left(\frac{1}{2} \dot{x}^2 - \frac{1}{2} x^2 + \varepsilon \hat{f} \cos \omega t x \right) dt - \int_0^T \varepsilon c |\dot{x}| \dot{x} \delta x dt = 0.$$

Introducing $\tau = \omega t$, we rewrite the latter in the form

$$\delta \int_0^{2\pi} \left(\frac{1}{2} \omega^2 x'^2 - \frac{1}{2} x^2 + \varepsilon \hat{f} \cos \tau x \right) d\tau - \int_0^{2\pi} \varepsilon c \omega^2 |x'| x' \delta x d\tau = 0.$$

At the first step of the variational-asymptotic procedure we put $\varepsilon = 0$ which leads to $\omega = 1$ and

$$x = A \cos \tau + B \sin \tau.$$

At the second step we introduce the slow time $\eta = \varepsilon \tau$ and look for the solution and correction to the frequency in the form

$$x(\tau) = x_0(\tau, \eta) + x_1(\tau, \eta), \quad \omega = 1 + \omega_1,$$

where

$$x_0(\tau, \eta) = A(\eta) \cos \tau + B(\eta) \sin \tau,$$

and x_1 and ω_1 are much smaller than x_0 and 1, respectively. Substituting this into the variational equation, one can reduce it to

$$\delta \int_0^{2\pi} \left[\frac{1}{2} x_{1,\tau}^2 - \frac{1}{2} x_1^2 + (2\varepsilon A_{,\eta} + 2\omega_1 B) \sin \tau x_1 + (-2\varepsilon B_{,\eta} + 2\omega_1 A + \varepsilon \hat{f}) \cos \tau x_1 + \text{nonresonant terms} \right] d\tau = 0.$$

Equating the resonant terms to zero, we obtain

$$\begin{aligned} 2A_{,\eta} + 2\frac{\omega_1}{\varepsilon} B &= 0, \\ 2B_{,\eta} - 2\frac{\omega_1}{\varepsilon} A &= \hat{f}. \end{aligned}$$

The fixed point of this system, $B = 0$ and $A = -\varepsilon \hat{f} / 2\omega_1$, corresponds to the steady-state vibration. Thus, the steady-state amplitude is given by

$$a = \sqrt{A^2 + B^2} = \varepsilon \hat{f} / 2|\omega_1|.$$

Taking into account that $\omega = 1 + \omega_1$, we get the following amplitude-frequency relation

$$a = \begin{cases} \frac{\varepsilon \hat{f}}{2(1-\omega)} & \text{for } \omega < 1, \\ \frac{\varepsilon \hat{f}}{2(\omega-1)} & \text{otherwise.} \end{cases}$$

EXERCISE 6.9. Resonant excitation. Consider the forced Duffing's oscillator described by the equation

$$\ddot{x} + x + \varepsilon c \dot{x} + \varepsilon \alpha x^3 = \hat{f} \cos \omega t,$$

where ε is small, but \hat{f} is finite (sometimes called a "hard excitation"). Apply the variational-asymptotic method to show that, to $O(\varepsilon)$, the only resonant excitation frequencies are 1, 3, and 1/3.

Solution. The above differential equation can be derived from the variational equation

$$\delta \int_0^T \left(\frac{1}{2} \dot{x}^2 - \frac{1}{2} x^2 - \frac{1}{4} \varepsilon \alpha x^4 + \hat{f} \cos \omega t x \right) dt - \int_0^T \varepsilon c \dot{x} \delta x dt = 0.$$

At the first step of the variational-asymptotic method we put $\varepsilon = 0$ to obtain

$$\delta \int_0^T \left(\frac{1}{2} \dot{x}^2 - \frac{1}{2} x^2 + \hat{f} \cos \omega t x \right) dt = 0.$$

The extremal of this functional satisfies the equation

$$\ddot{x} + x = \hat{f} \cos \omega t$$

yielding

$$x = \frac{\hat{f}}{1 - \omega^2} \cos \omega t + A \cos t + B \sin t.$$

We see that the resonance occurs at $\omega = 1$. Consider now the case $\omega \neq 1$. At the second step we introduce the slow time $\eta = \varepsilon t$ and look for the solution in the form

$$x(t) = x_0(t, \eta) + x_1(t, \eta),$$

where

$$x_0(t, \eta) = \frac{\hat{f}}{1 - \omega^2} \cos \omega t + A(\eta) \cos t + B(\eta) \sin t,$$

and x_1 is much smaller than x_0 in the asymptotic sense. We assume that x_1 is 2π -periodic with respect to t . We substitute $x(t)$ into the above variational equation for $T = 2\pi$ and keep the asymptotically principal terms containing x_1 and principal cross terms between x_0 and x_1

$$\delta \int_0^{2\pi} \left(\frac{1}{2} \dot{x}_1^2 + \underline{\dot{x}_0 \dot{x}_1} - \frac{1}{2} x_1^2 - \underline{x_0 x_1} - \varepsilon \alpha x_0^3 x_1 + \underline{\hat{f} \cos \omega t x_1} - \varepsilon c \dot{x}_0 x_1 \right) dt = 0.$$

Integrating the second term by part using the periodicity of x_1 , we see that the underlined terms give $2\varepsilon(A, \eta \sin t - B, \eta \cos t)x_1$. We expand the fifth term containing x_0^3 and transform the products of sine and cosine into the sum of harmonic functions. As a result, we get among others the following terms

$$c_1 \cos 3\omega t x_1 \quad \text{and} \quad [c_3 \cos(2 - \omega)t + c_4 \sin(2 - \omega)t]x_1.$$

They become resonant if $\omega = 1/3$ or $\omega = 3$. Thus, we have, in addition to $\omega = 1$, two other resonant excitation frequencies $\omega = 1/3$ and $\omega = 3$.

EXERCISE 6.10. Study the excitation of 3:1 subharmonic resonance in the previous exercise by setting $\omega = 3 + k\varepsilon$. Obtain a slow flow of the coefficients $A(\eta)$ and $B(\eta)$. Then transform to the polar coordinates $a(\eta)$ and $\psi(\eta)$ and look for fixed points of those equations. Eliminate ψ in order to find a relation between a^2 and other parameters. For $\varepsilon = 0.1$, $\alpha = c = \hat{f} = 1$, $k = 0$ simulate the exact and approximate solutions and compare them.

Solution. We continue the solution of the previous exercise by setting $\omega = 3 + k\varepsilon$ and write $x_0(t, \eta)$ in the form

$$x_0(t, \eta) = \lambda \cos(3t + k\eta) + A(\eta) \cos t + B(\eta) \sin t, \quad \lambda = \frac{\hat{f}}{1 - \omega^2}.$$

Substituting the Ansatz $x(t) = x_0(t, \eta) + x_1(t, \eta)$ into the variational equation and keeping the asymptotically principal terms containing $x_1(t, \eta)$, we reduce it to

$$\delta \int_0^{2\pi} \left[\frac{1}{2} \dot{x}_{1,t}^2 - \frac{1}{2} x_1^2 + (\dots) \sin t x_1 + (\dots) \cos t x_1 + \text{nonresonant terms} \right] dt = 0.$$

The consistency condition requiring the vanishing resonant terms leads to

$$2A_{,\eta} = \alpha \left[\frac{3}{4}B(A^2 + B^2) + \frac{3}{2}B\lambda^2 - \frac{3}{4}\lambda(A^2 - B^2) \sin k\eta - \frac{3}{2}\lambda AB \cos k\eta \right] - cA,$$

$$2B_{,\eta} = -\alpha \left[\frac{3}{4}A(A^2 + B^2) + \frac{3}{2}A\lambda^2 + \frac{3}{4}\lambda(A^2 - B^2) \cos k\eta - \frac{3}{2}\lambda AB \sin k\eta \right] - cB.$$

The obtained system of equations can be simplified by using polar coordinates a and ψ according to

$$A = a \cos \psi, \quad B = a \sin \psi.$$

Multiplying the first equation by A , the second one by B , and adding them, we obtain

$$a_{,\eta} = -\frac{3}{8}\alpha\lambda a^2 \sin(3\psi + k\eta) - \frac{c}{2}a.$$

Multiplying the first equation by B and subtracting it from the second multiplied by A , we get, after some algebra,

$$\psi_{,\eta} = -\frac{3}{4}\alpha(\lambda^2 + \frac{1}{2}a^2) - \frac{3}{8}\alpha\lambda a \cos(3\psi + k\eta).$$

To transform this system of equations into an autonomous system we introduce a new unknown function $\varphi = 3\psi + k\eta$ and write

$$a_{,\eta} = -\frac{3}{8}\alpha\lambda a^2 \sin \varphi - \frac{c}{2}a,$$

$$\varphi_{,\eta} = k - \frac{9}{4}\alpha(\lambda^2 + \frac{1}{2}a^2) - \frac{9}{8}\alpha\lambda a \cos \varphi.$$

In terms of a and φ the approximate solution of the original equation, to the order $O(\varepsilon)$, reads

$$x(t) = \lambda \cos(3t + k\varepsilon t) + a(\varepsilon t) \cos\left[t - \frac{1}{3}(\varphi - k\varepsilon t)\right].$$

The steady-state vibrations due to the second term correspond to the fixed points of the slow flow system for which

$$\frac{c}{2}a = -\frac{3}{8}\alpha\lambda a^2 \sin \varphi,$$

$$\left(k - \frac{9}{4}\alpha\lambda^2\right)a - \frac{9}{8}\alpha a^3 = \frac{9}{8}\alpha\lambda a^2 \cos \varphi.$$

Eliminating φ from this system, we obtain the frequency-amplitude equation

$$\left[\frac{9}{4}c^2 + \left(k - \frac{9}{4}\alpha\lambda^2 - \frac{9}{8}\alpha a^2 \right)^2 \right] a^2 = \frac{81}{64}\alpha^2 \lambda^2 a^4.$$

Thus, either $a = 0$ or

$$\frac{9}{4}c^2 + \left(k - \frac{9}{4}\alpha\lambda^2 - \frac{9}{8}\alpha a^2\right)^2 = \frac{81}{64}\alpha^2\lambda^2 a^2,$$

which is quadratic in a^2 . Its roots are

$$a^2 = p \pm \sqrt{p^2 - q},$$

where

$$p = \frac{8}{9}\frac{k}{\alpha} - \frac{3}{2}\lambda^2, \quad q = \frac{64}{81\alpha^2} \left[\frac{9}{4}c^2 + \left(k - \frac{9}{4}\alpha\lambda^2\right)^2 \right].$$

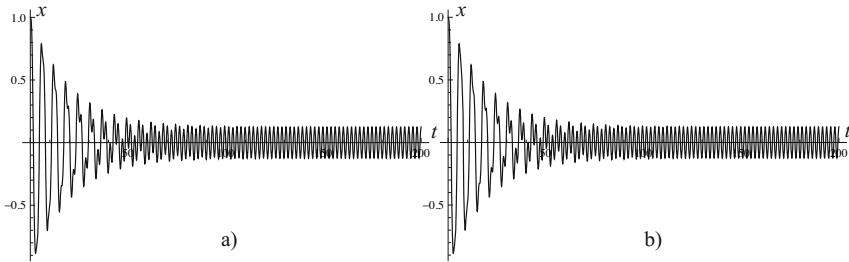

Fig. 6.24 Simulation of the exact and approximate solution: a) exact solution of the forced Duffing’s equation with hard excitation, b) approximate solution based on the slow flow system

Fig. 6.24 represents the results of numerical simulation of the exact and approximate solutions for $\varepsilon = 0.1$, $\alpha = c = \hat{f} = 1$, $k = 0$ which shows a good agreement. One can see that the steady-state amplitude a goes to zero as t goes to infinity in this case. Note that q is always positive, and thus, non-trivial steady-state free-oscillation amplitudes occur when $p > 0$ and $p^2 \geq q$.

EXERCISE 6.11. Solve the slow flow system (6.37) numerically for $\varepsilon = 0.1$, $k_1 = 0.2$ and $k_1 = 0.5$, with the initial conditions $a(0) = 1$ and $\psi(0) = 0$. Plot the curves $a(\tau)$ together with the numerical solutions shown in Figs. 6.17 and 6.18.

Solution. The slow flow system

$$\begin{aligned} a_{,\eta} &= \frac{a}{8}(4 - a^2) + \frac{\hat{f}}{2} \sin \psi, \\ \psi_{,\eta} &= k_1 + \frac{\hat{f}}{2a} \cos \psi, \end{aligned}$$

can be solved numerically in *Mathematica* by the following commands

```
sol = NDSolve[{{a'[t] == ε  $\frac{a[t]}{8}$  (4 - a[t]^2) +  $\frac{f}{2}$  ε Sin[ψ[t]],
  ψ'[t] == 0.2 ε +  $\frac{f}{2 a[t]}$  ε Cos[ψ[t]], a[0] == 1, ψ[0] == 0}, {a, ψ}, {t, 0, 500}]
Plot[{Evaluate[a[t] /. sol], Evaluate[-a[t] /. sol]}, {t, 0, 500}]
```

Since we want to plot a as function of the real time t , we use the relation $d/d\eta = (1/\epsilon)d/dt$ and solve the above system multiplied by ϵ . The values of parameters have been chosen as $\epsilon = 0.1$, $f = 1.06$, and $k_1 = 0.2$ ($k_1 = 0.5$). The plotted curves were shown together with the corresponding numerical solutions of equation (6.32) in Figs. 6.17 and 6.18.

EXERCISE 6.12. Resonant excitation. Consider the forced van der Pol's oscillator described by the equation

$$\ddot{x} + x - \epsilon(1 - x^2)\dot{x} = \hat{f} \cos \omega t,$$

where ϵ is small, but \hat{f} is finite. Apply the variational-asymptotic method to show that to $O(\epsilon)$, the only resonant excitation frequencies are 1, 3, and 1/3.

Solution. The above differential equation can be derived from the variational equation

$$\delta \int_0^T (\frac{1}{2}\dot{x}^2 - \frac{1}{2}x^2 + \hat{f} \cos \omega t x) dt + \int_0^T \epsilon(1 - x^2)\dot{x}\delta x dt = 0.$$

At the first step of the variational-asymptotic method we put $\epsilon = 0$ to obtain

$$\delta \int_0^T (\frac{1}{2}\dot{x}^2 - \frac{1}{2}x^2 + \hat{f} \cos \omega t x) dt = 0.$$

The extremal of this functional reads

$$x = \frac{\hat{f}}{1 - \omega^2} \cos \omega t + A \cos t + B \sin t.$$

We see that the resonance occurs at $\omega = 1$. Consider now the case $\omega \neq 1$. At the second step we introduce the slow time $\eta = \epsilon t$ and look for the solution in the form

$$x(t) = x_0(t, \eta) + x_1(t, \eta),$$

where

$$x_0(t, \eta) = \frac{\hat{f}}{1 - \omega^2} \cos \omega t + A(\eta) \cos t + B(\eta) \sin t,$$

and x_1 is much smaller than x_0 in the asymptotic sense. We assume that x_1 is 2π -periodic with respect to t . We substitute $x(t)$ into the above variational equation for $T = 2\pi$ and keep the asymptotically principal terms containing x_1 and the principal cross terms between x_0 and x_1

$$\delta \int_0^{2\pi} \left[\frac{1}{2} \dot{x}_1^2 + \underline{\dot{x}_0 \dot{x}_1} - \frac{1}{2} x_1^2 - \underline{x_0 x_1} + \underline{\hat{f} \cos \omega t x_1} + \varepsilon (1 - x_0^2) \dot{x}_0 x_1 \right] dt = 0.$$

Integrating the second term by parts using the periodicity of x_1 , we see that the underlined terms give $2\varepsilon(A_{,\eta} \sin t - B_{,\eta} \cos t)x_1$. Expanding the last term and transforming products of sine and cosine into the harmonics, we obtain among others the following terms

$$(c_1 \cos 3\omega t + c_2 \sin 3\omega t)x_1 \text{ and } [c_3 \cos(2 - \omega)t + c_4 \sin(2 - \omega)t]x_1.$$

They become resonant if $\omega = 1/3$ or $\omega = 3$. Thus, we have, in addition to $\omega = 1$, two other resonant excitation frequencies $\omega = 1/3$ and $\omega = 3$.

Chapter 7

Coupled Oscillators

This chapter deals with finite amplitude vibrations of coupled oscillators having two or more degrees of freedom. As a rule, the governing equations are not integrable and can be solved only by numerical integration. The numerical solutions have to be visualized by the Poincaré map. For mechanical systems with weak coupling the variational-asymptotic method is applicable. This enables one to study, among others, the bifurcation of nonlinear normal modes, KAM-theory for coupled conservative oscillators, and synchronization of the coupled self-excited oscillators.

7.1 Conservative Oscillators

Differential Equations of Motion. To begin with, let us consider some simple nonlinear coupled conservative oscillators.

EXAMPLE 7.1. Nonlinear mass-spring oscillators. Two equal masses m move horizontally under the action of three springs with cubic nonlinearity (see Fig. 7.1). Derive the equations of motion for these oscillators.

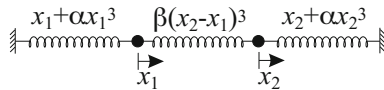

Fig. 7.1 Coupled oscillators with nonlinear springs

Let x_1 and x_2 be the displacements from the equilibrium positions of the point-masses and let $x = (x_1, x_2)$. The kinetic energy of the masses is given by

$$K(\dot{x}) = \frac{1}{2}m(\dot{x}_1^2 + \dot{x}_2^2).$$

We assume that all springs are nonlinear, but the connecting spring differs from the anchor springs. We write the potential energy of the springs in the form

$$U(x) = \frac{1}{2}k[x_1^2 + \frac{\alpha}{2l_0^2}x_1^4 + x_2^2 + \frac{\alpha}{2l_0^2}x_2^4 + \frac{\beta}{2l_0^2}(x_2 - x_1)^4].$$

Thus, Lagrange's equations are

$$m\ddot{x}_1 + kx_1 + k\frac{\alpha}{l_0^2}x_1^3 - k\frac{\beta}{l_0^2}(x_2 - x_1)^3 = 0,$$

$$m\ddot{x}_2 + kx_2 + k\frac{\alpha}{l_0^2}x_2^3 + k\frac{\beta}{l_0^2}(x_2 - x_1)^3 = 0.$$

Dividing these equations by kl_0 and introducing the dimensionless quantities

$$\bar{t} = \omega_0 t, \quad \bar{x}_i = \frac{x_i}{l_0}, \quad i = 1, 2,$$

where $\omega_0 = \sqrt{k/m}$, we rewrite them as (the bar is dropped)

$$\begin{aligned} \ddot{x}_1 + x_1 + \alpha x_1^3 - \beta(x_2 - x_1)^3 &= 0, \\ \ddot{x}_2 + x_2 + \alpha x_2^3 + \beta(x_2 - x_1)^3 &= 0. \end{aligned} \quad (7.1)$$

EXAMPLE 7.2. A spring pendulum. A point mass m is attached to a linear spring of stiffness k that is swinging in the vertical plane as shown in Fig. 7.2. Derive the equations of motion for this pendulum.

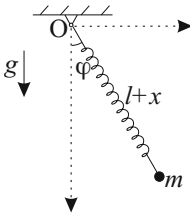

Denoting the elongation of the spring from the equilibrium length l by x , we write the kinetic and potential energies of the pendulum as

$$K(q, \dot{q}) = \frac{1}{2}m[\dot{x}^2 + (l+x)^2\dot{\varphi}^2],$$

$$U(q) = \frac{1}{2}kx^2 + mg(l+x)(1 - \cos \varphi) - mgx,$$

where $q = (x, \varphi)$. Lagrange's equations read

Fig. 7.2 Spring pendulum

$$m\ddot{x} + kx - m(l+x)\dot{\varphi}^2 - mg \cos \varphi = 0,$$

$$m(l+x)^2\ddot{\varphi} + mg(l+x)\sin \varphi + 2m(l+x)\dot{x}\dot{\varphi} = 0.$$

Dividing the first equation by m and the second one by $m(l+x)^2$, we obtain

$$\ddot{x} + \omega_2^2 x - (l+x)\dot{\varphi}^2 - g \cos \varphi = 0,$$

$$\ddot{\varphi} + \frac{g \sin \varphi + 2\dot{x}\dot{\varphi}}{l+x} = 0,$$

where $\omega_2^2 = k/m$.

Note that the linearization of the above equations leads to uncoupled equations describing two independent modes of vibrations: a spring mode with a frequency

ω_2 and a pendulum mode with a frequency $\omega_1 = \sqrt{g/l}$. However, when $\omega_2 \approx 2\omega_1$ the two modes are coupled causing the energy transfer between them.

EXAMPLE 7.3. Chain of nonlinear mass-spring oscillators. A chain of points of equal mass m connected by identical nonlinear springs is constrained to move in the longitudinal direction (see Fig. 7.3). Derive the equation of motion.

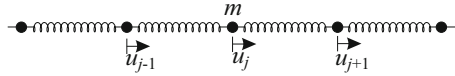

Fig. 7.3 Chain of nonlinear mass-spring oscillators

Denoting the displacement of the point-mass j from the equilibrium position by $u_j(t)$ we write down the kinetic energy of the chain

$$K(\dot{u}) = \frac{1}{2}m \sum_j \dot{u}_j^2.$$

The potential energy of the chain is the sum of energies of the springs. Considering the springs with cubic nonlinearity, we take the potential energy in the form

$$U(u) = \frac{1}{2}k \sum_j [(u_j - u_{j-1})^2 + \frac{\alpha}{2l_0^2}(u_j - u_{j-1})^4],$$

where l_0 is the original length of the spring which is equal to the spacing between the point-masses in equilibrium. Here we assume that the ends of the chain are fixed: $u_0 = u_{n+1} = 0$. So, the chain has n degrees of freedom. Lagrange's equations of this chain read

$$m\ddot{u}_j + k[(u_j - u_{j-1}) + \frac{\alpha}{l_0^2}(u_j - u_{j-1})^3] - k[(u_{j+1} - u_j) + \frac{\alpha}{l_0^2}(u_{j+1} - u_j)^3] = 0$$

for all $j = 1, \dots, n$. Introducing the dimensionless quantities

$$\bar{t} = \omega_0 t, \quad \bar{u}_j = \frac{u_j}{l_0},$$

where $\omega_0 = \sqrt{k/m}$, we rewrite these equations in the form (the bar is dropped)

$$\ddot{u}_j + (u_j - u_{j-1}) + \alpha(u_j - u_{j-1})^3 - (u_{j+1} - u_j) - \alpha(u_{j+1} - u_j)^3 = 0.$$

Hamilton's Equations. The equations of motion derived in the previous paragraph are differential equations of second order. As a rule they are not integrable and can be solved only by numerical integration. For this purpose it is more convenient to

transform them from Lagrange's to the equivalent Hamilton's form.¹ This transformation is quite straightforward. Let us do it in the most general case.

We take the differential of the Lagrange function as function of the generalized coordinates $q = (q_1, \dots, q_n)$ and velocities $\dot{q} = (\dot{q}_1, \dots, \dot{q}_n)$

$$dL = \sum_{j=1}^n \left(\frac{\partial L}{\partial q_j} dq_j + \frac{\partial L}{\partial \dot{q}_j} d\dot{q}_j \right).$$

We introduce the generalized impulses as $p = (p_1, \dots, p_n)$, where $p_j = \partial L / \partial \dot{q}_j$. Then Lagrange's equations becomes

$$\dot{p}_j = \frac{\partial L}{\partial q_j}.$$

Thus, the above differential can be written as

$$dL = \sum_{j=1}^n (\dot{p}_j dq_j + p_j d\dot{q}_j).$$

Since the second term in the summand is equal to $p_j d\dot{q}_j = d(p_j \dot{q}_j) - \dot{q}_j dp_j$, we present this equation in the form

$$d\left(\sum_{j=1}^n p_j \dot{q}_j - L\right) = \sum_{j=1}^n (-\dot{p}_j dq_j + \dot{q}_j dp_j). \quad (7.2)$$

The expression in parentheses on the left-hand side represents energy of the system; cf. (2.28). Expressing it in terms of the coordinates and impulses means doing Legendre's transform [5] of $L(q, \dot{q})$ with respect to \dot{q} . We call the result Hamilton function

$$H(q, p) = \sum_{j=1}^n p_j \dot{q}_j - L.$$

Equation (7.2) then implies

$$\dot{q}_j = \frac{\partial H}{\partial p_j}, \quad \dot{p}_j = -\frac{\partial H}{\partial q_j}, \quad (7.3)$$

for all $j = 1, 2, \dots, n$. These are the equations of motion in Hamilton's (or canonical) form. For any conservative mechanical system with n degrees of freedom this system of $2n$ differential equations of first order replaces n differential equations of second order. If the Hamilton function does not depend explicitly on time, then

¹ Except the convenience for numerical integration Hamilton's form of equations of motion provides a number of advantages just as the representation of motion as a phase curve in the phase space, the treatment of various theoretical questions of mechanics as well as the links to physics and thermodynamics [5].

$$\frac{d}{dt}H = \sum_{j=1}^n \left(\frac{\partial H}{\partial q_j} \dot{q}_j + \frac{\partial H}{\partial p_j} \dot{p}_j \right) = 0,$$

so the conservation of the energy $H(q, p) = E_0$ follows.

For the coupled oscillators in example 7.1 the dimensionless Hamilton's function reads

$$H(q, p) = \frac{1}{2}(p_1^2 + p_2^2) + \frac{1}{2}[q_1^2 + \frac{\alpha}{2}q_1^4 + q_2^2 + \frac{\alpha}{2}q_2^4 + \frac{\beta}{2}(q_2 - q_1)^4], \quad (7.4)$$

where $x_1 = q_1$ and $x_2 = q_2$. Hamilton's equations become

$$\begin{aligned} \dot{q}_1 &= p_1, & \dot{p}_1 &= -q_1 - \alpha q_1^3 + \beta(q_2 - q_1)^3, \\ \dot{q}_2 &= p_2, & \dot{p}_2 &= -q_2 - \alpha q_2^3 - \beta(q_2 - q_1)^3. \end{aligned} \quad (7.5)$$

Phase Curves and Poincaré Map. Just as for single oscillators, the solutions of Hamilton's equations (7.3) for coupled oscillators may be drawn as phase curves in the $2n$ -dimensional (q, p) -phase space. There is only one phase curve passing through a given point of the phase space. Therefore, one may think of points in the phase space as particles of some fluid which move in accordance with Hamilton's equations. This motion generates a flow with an interesting property that it conserves volumes of the phase space (Liouville's theorem). This means that if we draw all phase curves that begin from points inside a region of volume V in the phase space at time $t = 0$, then the end points of these phase curves at time t fill a region with the same volume. Indeed, the velocity of this Hamilton's flow, (\dot{q}, \dot{p}) , is divergent-free

$$\operatorname{div}(\dot{q}, \dot{p}) = \sum_{j=1}^n \left(\frac{\partial \dot{q}_j}{\partial q_j} + \frac{\partial \dot{p}_j}{\partial p_j} \right) = \sum_{j=1}^n \left(\frac{\partial^2 H}{\partial p_j \partial q_j} - \frac{\partial^2 H}{\partial q_j \partial p_j} \right) = 0,$$

which implies Liouville's theorem.

To see what the phase curves look like let us turn to example 7.1. Equations (7.5) do not permit in general analytical solutions except perhaps, the case $\beta = 0$ for which the oscillators become uncoupled. We analyze first this simple case. Since now the oscillators are uncoupled, the energy of each of them is conserved

$$\frac{1}{2}p_j^2 + \frac{1}{2}q_j^2 + \frac{\alpha}{4}q_j^4 = E_{j0}, \quad j = 1, 2.$$

This leads immediately to the solution in form of elliptic integrals obtained already in Section 5.1

$$t = t_0 \pm \int_{q_{j0}}^{q_j} \frac{dx}{\sqrt{2E_{j0} - x^2 - \frac{\alpha}{2}x^4}}.$$

Based on this solution we may express q_j and p_j as periodic functions of t with two different periods

$$T_j = 2 \int_{q_{jm}}^{q_{jM}} \frac{dx}{\sqrt{2E_{j0} - x^2 - \frac{\alpha}{2}x^4}}.$$

Note that the periods T_j as well as the corresponding frequencies $\omega_j = 2\pi/T_j$ depend on the initial energies of the oscillators. It turns out that for integrable systems there exist always angle-action variables (φ, I) , with $\varphi = (\varphi_1, \dots, \varphi_n)$ and $I = (I_1, \dots, I_n)$, in terms of which the Hamilton function becomes independent of φ : $H = H(I)$ (see [5]). The solution of Hamilton's equations

$$\dot{\varphi}_j = \frac{\partial H}{\partial I_j} = \omega_j(I_j), \quad \dot{I}_j = -\frac{\partial H}{\partial \varphi_j} = 0$$

is quite simple in these variables: $\varphi_j = \omega_j t + \varphi_{j0}$ and $I_j = \text{const}$. For our uncoupled oscillators the action variables I_j are computed as follows

$$I_j = \frac{1}{2\pi} \oint p_j dq_j,$$

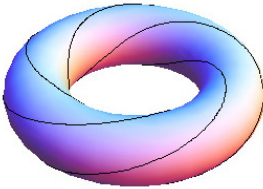

Fig. 7.4 A phase curve on torus

while the angle variables φ_j correspond to the angular times. Topologically, each phase curve can then be regarded as a curve on a 2-D torus shown in Fig. 7.4. If the frequency ratio ω_2/ω_1 is a rational number, then the phase curves are closed orbits on

the torus corresponding to the periodic motions. If this ratio is irrational, the phase curves wind around endlessly on the torus and correspond to the quasiperiodic motions (cf. the Lissajous figures in exercise 2.5). The tori are called invariant because each phase curve starting on some torus stays there forever. By changing the energy of one of the oscillators, we get the one-parameter family of invariant tori which fill the whole three-dimensional energy level surface.

As soon as $\beta \neq 0$ we expect that Hamilton's equations of these coupled oscillators become non-integrable. KAM theory which will be considered in Section 7.3 predicts that for sufficiently small β most of invariant tori, corresponding to irrational frequency ratios and called non-resonant tori, survive this small disturbance: they are just slightly deformed. The resonant tori and maybe some of the non-resonant tori are destroyed by the disturbance, resulting in layers of chaotic motion and filling the space between preserved tori. However, the volume of the chaotic motion and destroyed tori tends to zero as $\beta \rightarrow 0$ (see Section 7.3).

Thus, from what is said above it is clear that, for $\beta \neq 0$, the only way to obtain the solution is to do numerical integration. Assume that we have found by numerical integration a particular solution of (7.5) satisfying the initial conditions $q(0) = q_0$ and $p(0) = p_0$. Then the question arises: how can we visualize the phase curve in the four-dimensional phase space? One circumstance makes this visualization easier: due to the energy conservation the phase curve must lie on the 3-D energy level surface

$$H(q_1, q_2, p_1, p_2) = E_0, \tag{7.6}$$

with E_0 being the initial energy. However, it is still difficult for us to draw a curve on a 3-D energy level surface given *implicitly* in this form. A great help came from Poincaré, who introduced a fixed 2-D cut plane traverse to the flow. If we plot the intersection of the phase curve with this plane, the generated map, called Poincaré map, (cf. Fig. 6.8), enables one to follow the traces of the phase curve on this plane.

The Poincaré map can be constructed numerically as follows. First, we use the energy conservation to find the initial velocity $p_1(0)$ from the randomly chosen initial data for q_1, q_2, p_2 . Next, the numerical integration generates trajectories lying on the three-dimensional energy level surface. Finally, we pick out points of intersection of trajectories crossing the cut plane $q_1 = 0$ with the positive velocity $p_1 > 0$. In this case the Poincaré section is defined by

$$\Sigma = \{q_1 = 0, p_1 > 0\}.$$

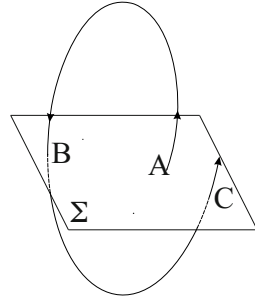

Fig. 7.5 Poincaré map

Note that an additional restriction on the sign of the velocities at the intersecting points is posed. The reason is that we want the Poincaré map to be orientation preserving [20]. In Fig. 7.5 this is realized by counting only points A and C, but not point B where the trajectory crosses the cut plane with a negative velocity.

Imposing condition (7.6) and $q_1 = 0$ for the specific Hamilton’s function (7.4) we obtain

$$p_1 = \pm \sqrt{2E_0 - \frac{1}{2}(\alpha + \beta)q_2^4 - q_2^2 - p_2^2}.$$

Together with (7.6) this defines the Poincaré map for the coupled mass-spring non-linear oscillators. The points of the Poincaré map fill the interior of a region with the boundary corresponding to the condition $p_1 = 0$

$$2E_0 = \frac{1}{2}(\alpha + \beta)q_2^4 + q_2^2 + p_2^2.$$

Numerical Simulations. Numerical simulations of the Poincaré maps require a little bit more elaborated commands in *Mathematica* than those used in previous Chapters to simulate the phase curves in the 2-D phase plane. We took here the code originally written by E. Weisstein² and slightly modified it to adapt to our particular problem.

The Poincaré maps of the dynamical system (7.5) are shown in Fig. 7.6 for the fixed energy level $E_0 = 0.4$ and for $\alpha = 1$ in two cases: a) $\beta = 0.1$ (left), and b) $\beta = 0.4$ (right). Looking at these Poincaré maps we can recognize the qualitatively

² This open source code, together with some explanations, can be found on the website <http://mathworld.wolfram.com/notebooks/DynamicalSystems/SurfaceofSection.nb>

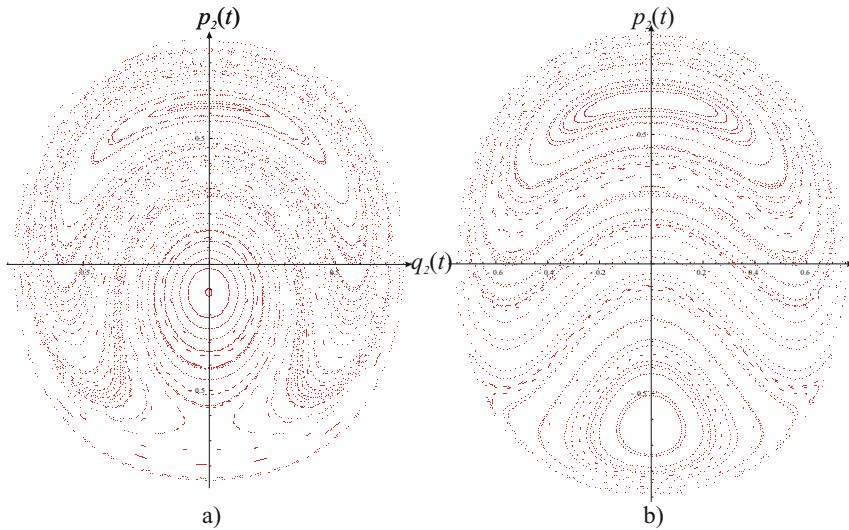

Fig. 7.6 Poincaré maps for $E_0 = 0.4$ and $\alpha = 1$: a) $\beta = 0.1$, b) $\beta = 0.4$

different behavior in case a) and b). In case b) there are two fixed points corresponding to the periodic solutions³ with $q_2 = q_1$ and $q_2 = -q_1$. Such special periodic solutions are called nonlinear normal modes. Both symmetric ($q_2 = q_1$) and antisymmetric normal modes ($q_2 = -q_1$) are orbitally stable as they are surrounded by points of intersections of trajectories on non-resonant invariant tori with the Poincaré section. It turns out that the bifurcation occurs for $\beta < 1/4$. For these values of β the antisymmetric mode becomes unstable, whereas the two bifurcating modes are orbitally stable. Note the closed loop starting and ending at the unstable saddle point and resembling the separatrix in 2-D case (in fact, there are two such loops, but the second one is difficult to observe as it is very near to the boundary curve of the plot). This path is called a “homoclinic orbit” [49] and is formed by trajectories that approach the saddle point after an infinite number of positive and negative iterations. The homoclinic orbits are recognized as a mechanism for generation of chaotic motions in weakly coupled oscillators.

It is interesting to note that this type of bifurcation for nonlinear coupled oscillators is sensitive only to the ratio $\beta/\alpha = \kappa$, called a coupling factor, as shown in Fig. 7.7. In this case $\alpha = 0.1$ while $\beta = 0.01$ and 0.04 so that the coupling factor remains the same as in the previous simulations. In the next Section we will use this fact to provide the asymptotic analysis of the variational problem containing the small parameters α and β .

³ The proof of existence of at least n periodic solutions passing through each stable equilibrium state for conservative mechanical system having n degrees of freedom at any fixed level of energy can be found in [34, 52].

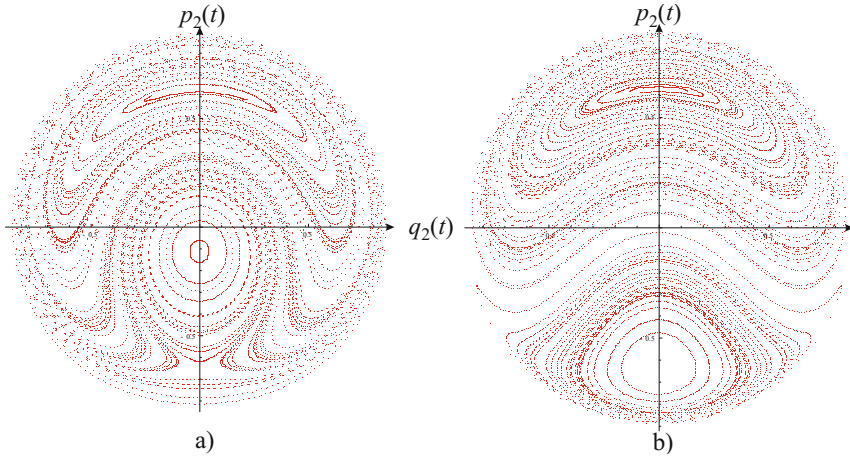

Fig. 7.7 Poincaré maps for $E_0 = 0.4$ and $\alpha = 0.1$: a) $\beta = 0.01$, b) $\beta = 0.04$

7.2 Bifurcation of Nonlinear Normal Modes

This Section analyzes the bifurcation of nonlinear normal modes observed by numerical integration in the previous Section with the help of the variational-asymptotic method.

Nonlinear Normal Modes and the Modal Equation. Let us turn back to Lagrange’s equations (7.1) for the nonlinear coupled oscillators and rewrite them in the form

$$\ddot{x} = -\frac{\partial U}{\partial x}, \quad \ddot{y} = -\frac{\partial U}{\partial y}, \tag{7.7}$$

where $x = x_1, y = x_2$, and $U(x, y)$ is the potential energy. As we know, the energy of this system is conserved

$$\frac{1}{2}(\dot{x}^2 + \dot{y}^2) + U(x, y) = E_0.$$

We seek the nonlinear normal modes as periodic solutions by assuming y as a function of x , without direct reference to time t , and try to eliminate t in these equations. Using the chain rule

$$\dot{y} = y'\dot{x}, \quad \ddot{y} = y''\dot{x}^2 + y'\ddot{x},$$

with prime denoting the derivative of y with respect to x , and substituting this into the second of (7.7) to get

$$-\frac{\partial U}{\partial y} = y''\dot{x}^2 - y'\frac{\partial U}{\partial x}. \tag{7.8}$$

Next, we substitute \dot{y} into the energy conservation

$$\frac{1}{2}\dot{x}^2(1+y^2) + U(x,y) = E_0.$$

Solving this equation with respect to \dot{x} and substituting into (7.8), we obtain finally

$$2(E_0 - U)y'' + (1+y^2)\left(\frac{\partial U}{\partial y} - y'\frac{\partial U}{\partial x}\right) = 0. \tag{7.9}$$

This is the differential equation to determine the nonlinear normal modes, called a modal equation.

The system of coupled oscillators in example 7.1, due to its symmetry, admits quite simple nonlinear normal modes for which $y = cx$. Such normal modes are called similar normal modes. Indeed, substituting this form of solution into (7.9) and keeping in mind that

$$U(x,y) = \frac{1}{2}\left[x^2 + \frac{\alpha}{2}x^4 + y^2 + \frac{\alpha}{2}y^4 + \frac{\beta}{2}(y-x)^4\right],$$

we obtain

$$\frac{\partial U}{\partial y} - y'\frac{\partial U}{\partial x} = cx + \alpha c^3x^3 + \beta(c-1)^3x^3 - c[x + \alpha x^3 - \beta x^3(c-1)^3] = 0.$$

A simple algebra reduces this to

$$(c-1)(c+1)[c + \kappa(c-1)^2] = 0,$$

where $\kappa = \beta/\alpha$ is the coupling factor introduced previously. This algebraic equation has four roots

$$c = 1, -1, 1 - \frac{1}{2\kappa} \pm \frac{1}{\kappa}\sqrt{1/4 - \kappa}. \tag{7.10}$$

The last two roots are real only if $\kappa < 1/4$. Thus, for $\kappa < 1/4$ there are two additional normal modes bifurcated out of the antisymmetric mode $y = -x$ (vibrations in counter-phases) at $\kappa = 1/4$ as shown in Fig. 7.8, where the bold line denotes the stable modes and the dashed line the unstable one. This confirms also our observation with the Poincaré maps obtained previously by numerical integration.

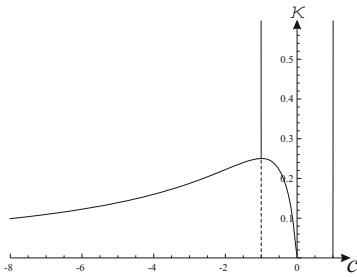

Fig. 7.8 Bifurcation of normal modes

Variational-Asymptotic Method. Since the normal symmetric and antisymmetric modes and the bifurcating modes found above are sensitive only to the coupling factor κ , we will consider the following variational problem: find the extremal of the functional

$$I[x(t), y(t)] = \frac{1}{2} \int_{t_0}^{t_1} [\dot{x}^2 + \dot{y}^2 - x^2 - \frac{\varepsilon}{2} x^4 - y^2 - \frac{\varepsilon}{2} y^4 - \frac{\varepsilon \kappa}{2} (y-x)^4] dt,$$

where ε is a small parameter and t_0 and t_1 are arbitrary time instants. We put for short $t_0 = 0$ and $t_1 = T$. This action functional describes the coupled oscillators with two weakly nonlinear anchor springs and the weak coupling through the connecting nonlinear spring. It is convenient to change to the normal coordinates

$$u = \frac{1}{2}(x+y), \quad v = \frac{1}{2}(x-y).$$

Then the action functional becomes

$$I[u(t), v(t)] = \int_0^T [\dot{u}^2 + \dot{v}^2 - u^2 - v^2 - \frac{\varepsilon}{4}(u+v)^4 - \frac{\varepsilon}{4}(u-v)^4 - 4\varepsilon\kappa v^4] dt. \quad (7.11)$$

To apply the variational-asymptotic method we put at the first step $\varepsilon = 0$ to obtain

$$I_0[u(t), v(t)] = \int_0^T (\dot{u}^2 + \dot{v}^2 - u^2 - v^2) dt.$$

This is the action functional describing vibrations of two uncoupled identical harmonic oscillators. The extremal is

$$u_0 = A_1 \cos t + B_1 \sin t, \quad v_0 = A_2 \cos t + B_2 \sin t, \quad (7.12)$$

for which the frequencies coincide so that the period T is 2π as expected.

As soon as $\varepsilon \neq 0$ the coefficients A_1, B_1, A_2, B_2 are becoming slightly dependent on time. Besides, taken for granted the bifurcation of modes for κ near $1/4$, we set $\kappa = 1/4 - \mu$ and look for the extremal at the second step in the two-timing fashion

$$\begin{aligned} u &= A_1(\eta) \cos t + B_1(\eta) \sin t + u_1(t, \eta), \\ v &= A_2(\eta) \cos t + B_2(\eta) \sin t + v_1(t, \eta), \end{aligned}$$

where $\eta = \varepsilon t$ is the slow time. We assume that $u_1(t, \eta)$ and $v_1(t, \eta)$ are 2π -periodic functions with respect to the fast time t and are much smaller than u_0 and v_0 in the asymptotic sense. Note that the asymptotically principal terms of the time derivatives of u and v are

$$\dot{u} = u_{0,t} + \varepsilon u_{0,\eta} + u_{1,t}, \quad \dot{v} = v_{0,t} + \varepsilon v_{0,\eta} + v_{1,t},$$

where the comma in indices denotes the partial derivatives. Substituting u, v and their derivatives into functional (7.11) and keeping the principal terms of u_1, v_1 and the principal cross terms between u_0, v_0 and u_1, v_1 we have

$$\begin{aligned}
I_1[u_1(t), v_1(t)] = & \int_0^{2\pi} [u_{1,t}^2 + v_{1,t}^2 + \underline{2u_{0,t}u_{1,t}} + \underline{2\varepsilon u_{0,\eta}u_{1,t}} + \underline{2v_{0,t}v_{1,t}} + \underline{2\varepsilon v_{0,\eta}v_{1,t}} \\
& - (u_1^2 + v_1^2 + \underline{2u_0u_1} + \underline{2v_0v_1}) - \varepsilon(2u_0^3u_1 + 6u_0v_0^2u_1 + 6u_0^2v_0v_1 \\
& + 2v_0^3v_1 + 16\kappa v_0^3v_1)] dt.
\end{aligned}$$

Integrating the third up to sixth terms by parts using the periodicity of u_1 and v_1 with respect to t , we see that the underlined terms gives $-4\varepsilon(u_{0,t\eta}u_1 + v_{0,t\eta}v_1)$. Then, substituting the expressions for u_0 and v_0 into the functional and reducing the products of sine and cosine to the sum of harmonic functions,⁴ we get the resonant terms which should be removed in order to be consistent with the above asymptotic expansion. The equations obtained for A_1, B_1, A_2, B_2 read

$$\begin{aligned}
A_{1,\eta} &= \frac{3}{8}B_1(A_1^2 + B_1^2) + \frac{3}{8}B_1(A_2^2 + B_2^2) + \frac{3}{4}B_2(A_1A_2 + B_1B_2), \\
B_{1,\eta} &= -\frac{3}{8}A_1(A_1^2 + B_1^2) - \frac{3}{8}A_1(A_2^2 + B_2^2) - \frac{3}{4}A_2(A_1A_2 + B_1B_2), \\
A_{2,\eta} &= \left(\frac{3}{8} + 3\kappa\right)B_2(A_2^2 + B_2^2) + \frac{3}{8}B_2(A_1^2 + B_1^2) + \frac{3}{4}B_1(A_1A_2 + B_1B_2), \\
B_{2,\eta} &= -\left(\frac{3}{8} + 3\kappa\right)A_2(A_2^2 + B_2^2) - \frac{3}{8}A_2(A_1^2 + B_1^2) - \frac{3}{4}A_1(A_1A_2 + B_1B_2).
\end{aligned}$$

The above equations can still be simplified in terms of the variables a_1, a_2 , and φ defined by

$$\begin{aligned}
A_1 &= a_1 \cos \phi_1, & B_1 &= a_1 \sin \phi_1, \\
A_2 &= a_2 \cos \phi_2, & B_2 &= a_2 \sin \phi_2, \\
\varphi &= \phi_2 - \phi_1.
\end{aligned} \tag{7.13}$$

According to these formulas a_1 and a_2 are the amplitudes of u and v , respectively, while φ is the phase difference modulo π . In terms of these new variables the equations of slow flow become (see exercise 7.7)

$$\begin{aligned}
a_{1,\eta} &= \frac{3}{8}a_1a_2^2 \sin 2\varphi, \\
a_{2,\eta} &= -\frac{3}{8}a_1^2a_2 \sin 2\varphi, \\
\varphi_{,\eta} &= -\frac{3}{8}(a_1^2 + a_2^2) + 3\mu a_2^2 + \frac{3}{8}(a_2^2 - a_1^2) \cos 2\varphi.
\end{aligned} \tag{7.14}$$

The Slow Flow. It follows from the first two equations of (7.14) that

$$\frac{da_1}{da_2} = -\frac{a_2}{a_1} \Rightarrow a_1^2 + a_2^2 = \rho^2,$$

⁴ Again, this can be done with the TrigReduce command in *Mathematica*.

which means the conservation of the energy at this approximation, since terms of the order ε^2 and higher are neglected. This first integral enables one to reduce system (7.14) to two differential equations. Indeed, let us introduce a new variable ψ according to

$$a_1 = \rho \cos \psi, \quad a_2 = \rho \sin \psi, \tag{7.15}$$

with ρ being a constant in the above conservation law. Substituting these formulas into the first and the last equations of (7.14) we obtain

$$\begin{aligned} \psi_{,\eta} &= -\frac{3\rho^2}{16} \sin 2\varphi \sin 2\psi, \\ \varphi_{,\eta} &= -\frac{3\rho^2}{16} [8\mu(\cos 2\psi - 1) + 2 + 2 \cos 2\psi \cos 2\varphi]. \end{aligned} \tag{7.16}$$

The obtained system of equations represents a slow flow on a two-dimensional torus, since the variables ψ and φ are modulo π .

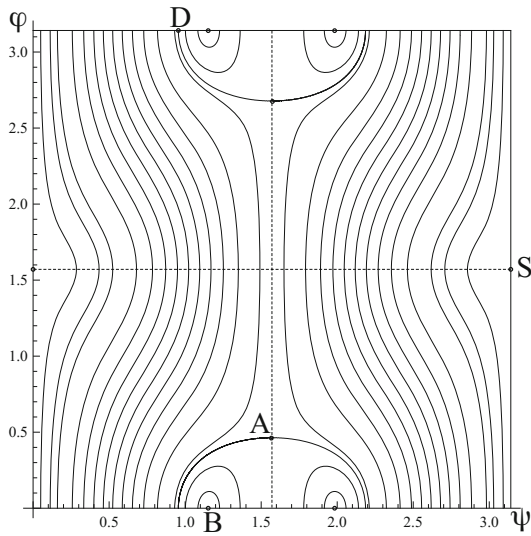

Fig. 7.9 Level curves of (7.17) for $\mu = 0.05$

In contrast to the original system (7.1), equations (7.16) can be integrated exactly. Indeed, by the straightforward differentiation we can easily verify that

$$-\frac{1}{2} \sin^2 2\psi \cos 2\varphi + (1 - 4\mu) \cos 2\psi + \mu \cos 4\psi = k \tag{7.17}$$

is the first integral of this slow flow, with k being a constant. The level curves of equation (7.17) are shown in Fig. 7.9 for $\mu = 0.05$. Each curve corresponds to a fixed value k of the first integral, but all are on the same energy level ρ^2 . Due to the

periodicity in ψ points lying on the lines $\psi = 0$ and $\psi = \pi$ have to be identified. The same is true of φ . As a result, this figure represents the flow on the two-dimensional torus. Observe the symmetry with respect to the dashed lines $\varphi = \pi/2$ and $\psi = \pi/2$.

As we know, the nonlinear normal modes (7.10) found from the modal equation correspond to the fixed points of this flow. Let us first consider the symmetric normal mode for which $x = y$ and $v = 0$. In this case $A_2 = B_2 = 0$ and $a_2 = 0$, $a_1 = \rho$. Therefore $\psi = 0$ and the second equation of (7.16) implies that $\varphi = \pi/2$. Thus, this symmetric mode corresponds to the fixed point $(\psi, \varphi) = (0, \pi/2)$ (or $(\pi, \pi/2)$ denoted by S). We see that this mode is orbitally stable as the fixed point is a center surrounded by closed curves that result as intersections of invariant tori with the cut plane. For the antisymmetric normal mode we have $x = -y$ and $u = 0$. Therefore $a_1 = 0$ and consequently $\psi = \pi/2$. The second equation of (7.16) implies that $\varphi = \frac{1}{2} \arccos(1 - 8\mu)$. Thus, the antisymmetric normal mode is orbitally unstable as it is represented by the saddle points $(\psi, \varphi) = (\pi/2, \frac{1}{2} \arccos(1 - 8\mu))$ (point A) and $(\psi, \varphi) = (\pi/2, \pi - \frac{1}{2} \arccos(1 - 8\mu))$. The homoclinic orbits are the closed curves starting and ending at these saddle points.⁵ The bifurcating modes satisfy the relations $u = \frac{1}{2}(1+c)x$ and $v = \frac{1}{2}(1-c)x$, so u and v are proportional and the phase difference φ must be zero. It follows from the second equation of (7.16) that $\psi = \frac{1}{2} \arccos \frac{4\mu-1}{4\mu+1}$ or $\psi = \pi - \frac{1}{2} \arccos \frac{4\mu-1}{4\mu+1}$. We see that these bifurcating modes are orbitally stable (since they appear as centers) and correspond to the fixed points $(\psi, \varphi) = (\frac{1}{2} \arccos \frac{4\mu-1}{4\mu+1}, 0)$ (point B) and $(\psi, \varphi) = (\pi - \frac{1}{2} \arccos \frac{4\mu-1}{4\mu+1}, 0)$, respectively.

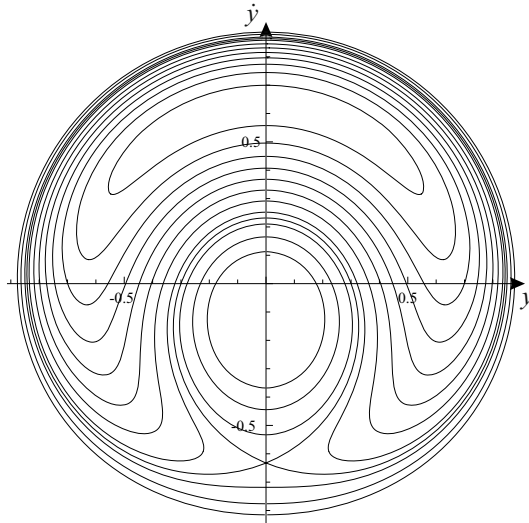

Fig. 7.10 Poincaré map according to approximate theory for $E_0 = 0.4$ and $\mu = 0.15$

⁵ See the detailed analysis of the homoclinic motion in [49].

Comparison with Numerical Simulations. The comparison with the Poincaré map constructed numerically in the previous Section is possible if we express the results obtained for u and v in terms of the “old” coordinates x and y

$$x = u + v, \quad y = u - v.$$

To compute the approximate Poincaré map we must set $x = 0$

$$x = u_0 + v_0 + O(\varepsilon) = 0,$$

so, taking into account (7.12) we have

$$\tan t = -\frac{A_2(\eta) + A_1(\eta)}{B_2(\eta) + B_1(\eta)}.$$

Finding from here $\sin t$ and $\cos t$ and substituting into $y = u_0 - v_0$ we obtain

$$y = \frac{2(B_1A_2 - A_1B_2)}{(B_2^2 + 2B_1B_2 + A_2^2 + 2A_1A_2 + B_1^2 + A_1^2)^{1/2}},$$

where the argument η from A_1, B_1, A_2, B_2 is omitted. The velocity \dot{y} , to the lowest order of approximation in ε , is

$$\dot{y} = y_{,t} = \frac{B_2^2 + A_2^2 - B_1^2 - A_1^2}{(B_2^2 + 2B_1B_2 + A_2^2 + 2A_1A_2 + B_1^2 + A_1^2)^{1/2}}.$$

In terms of the angles φ and ψ introduced in (7.13) and (7.15) the formulas for y and \dot{y} read

$$y = \frac{\rho \sin \varphi \sin 2\psi}{\sqrt{1 + \cos \varphi \sin 2\psi}}, \quad \dot{y} = \frac{\rho \cos 2\psi}{\sqrt{1 + \cos \varphi \sin 2\psi}}.$$

To construct the approximate Poincaré map we must use the first integral (7.17) to find $\cos 2\varphi$ for the given values of μ, k, ρ , and ψ . Then plugging the obtained values of φ into the above formulas to evaluate y and \dot{y} and to plot the curve in the cut plane. The total energy E_0 of the system is related to ρ by the expression $E_0 = \rho^2$. The approximate Poincaré map corresponding to the energy level $E_0 = 0.4$ and to the coupling factor $\kappa = 0.1$ ($\mu = 0.15$) is shown in Fig. 7.10. It is seen that both maps in Fig. 7.7 (left) and Fig. 7.10 coincide qualitatively.

To show the quantitative agreement let us compute the Poincaré map for $E_0 = 0.4$, $\varepsilon = 0.1$, and $\mu = 0.15$, and for a solution satisfying the following initial conditions

$$x(0) = 0, \quad y(0) = 0, \quad \dot{y}(0) = -0.65.$$

Then it is easy to find that $k = -0.2519$. The comparison of Poincaré maps obtained by the numerical integration (points) and by the approximate theory (bold line) is shown in Fig. 7.11 (see exercise 7.8). The agreement is really palpable, although $\varepsilon = 0.1$ is not quite small.

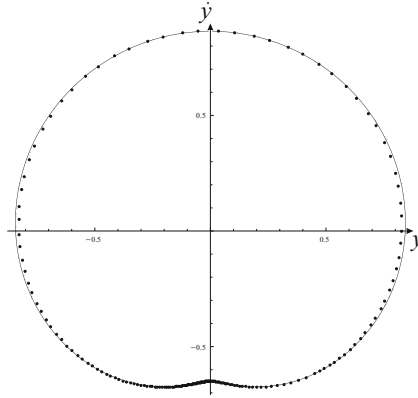

Fig. 7.11 Comparison of Poincaré maps for $E_0 = 0.4$, $\varepsilon = 0.1$, and $\kappa = 0.1$

7.3 KAM Theory

The perturbation theory of quasiperiodic motions of conservative mechanical systems [5, 25] proposed by Kolmogorov, Arnold, and Moser, called for short KAM theory, is perhaps one of the greatest achievements in mathematics and mechanics of the 20th century. It has a lot of consequences and applications in dynamics and also in statistical mechanics. Although the ideas upon which the theory is based seem quite simple, the detailed proofs presented in the mathematical literature have been for long time serious barriers for people with the engineering background. This Section aims at explaining KAM theory with the variational-asymptotic method.

Variational Problem. Our starting point is Hamilton's variational principle, according to which motions of any conservative mechanical system correspond to extremals of the action functional

$$I[q(t)] = \int_{t_0}^{t_1} L(q, \dot{q}) dt, \quad (7.18)$$

where $q(t) = (q_1(t), \dots, q_n(t))$. As we know, this implies Lagrange's equations

$$\frac{d}{dt} \frac{\partial L}{\partial \dot{q}_j} - \frac{\partial L}{\partial q_j} = 0, \quad j = 1, \dots, n.$$

Suppose that the Lagrange function has the form

$$L(q, \dot{q}) = L_0(q, \dot{q}) + \varepsilon L_1(q, \dot{q}),$$

where ε is a small parameter. Besides, we assume for simplicity that $L(q, \dot{q})$ is an analytic function and that the determinant $\det L_{, \dot{q} \dot{q}}$ is positive everywhere. The problem is to study the asymptotic behavior of the extremals depending on this small

parameter ε . Note that the number n of degrees of freedom must be at least 2 since systems with one degree of freedom are always integrable leading to the periodic extremals for small energies.

First Step. Since the action functional (7.18) contains a small parameter, it is natural to use the variational-asymptotic method to analyze it. At the first step of the variational-asymptotic method we neglect the small term $\varepsilon L_1(q, \dot{q})$ and consider instead the variational problem: find the extremal of the functional

$$I_0[q(t)] = \int_{t_0}^{t_1} L_0(q, \dot{q}) dt.$$

This leads to Lagrange's equations

$$\frac{d}{dt} \frac{\partial L_0}{\partial \dot{q}_j} - \frac{\partial L_0}{\partial q_j} = 0. \tag{7.19}$$

We assume that Lagrange's equations (7.19) are integrable so that their solutions can be found at this step. Such situation is met by the nonlinear coupled mass-spring oscillators considered in example 7.1 if the coupling parameter β is set to be zero. In this case the system reduces to two uncoupled nonlinear oscillators, each of which has only one degree of freedom.

As equations (7.19) are integrable, there exist angle-action variables (φ, I) in terms of which the unperturbed Hamilton function becomes independent of φ : $H_0 = H_0(I)$ (see Section 7.1 and [5]). The solution of Hamilton's equations

$$\dot{\varphi}_j = \frac{\partial H_0}{\partial I_j} = \omega_j(I_j), \quad \dot{I}_j = -\frac{\partial H_0}{\partial \varphi_j} = 0,$$

which are equivalent to (7.19), is quite simple in these variables: $\varphi_j = \varphi_{j0} + \omega_j t$ and $I_j = \text{const}$. Coming back to $q(t)$, the solution of (7.19) can be presented in the form

$$q(t) = q_0(t) = u_0(\varphi_0 + \omega t),$$

where $u_0(\varphi)$ is the vector-valued function of $\varphi = (\varphi_1, \dots, \varphi_n)$ which is periodic in each variable φ_j with the period 2π , and $\omega = (\omega_1, \dots, \omega_n)$ are the constant frequencies. Thus, every solution is now quasi-periodic in t : its frequency spectrum in general does not consist of integer multiples of a single frequency as in the case with periodic solutions, but rather of integer combinations of a finite number of different frequencies.⁶ For fixed φ_0 function $u_0(\varphi_0 + \omega t)$ describes a curve winding around some invariant n -dimensional torus T^n with winding numbers, $\omega = (\omega_1, \dots, \omega_n)$. Mention that $u_0(\varphi)$ is a differentiable one-to-one map which maps the invariant torus onto itself. We shall use angle variables $\varphi = (\varphi_1, \dots, \varphi_n)$, each is modulo 2π ,

⁶ In this sense, the asymptotic analysis provided here is multi-frequency analysis, which is much more difficult than all previous asymptotic analyses due to the problem of small divisors.

as coordinates on the torus. All solutions with fixed I_j belong to one torus, so that the whole phase space is foliated into an n -parameter family of invariant tori.

The flow on each torus depends on the arithmetical properties of its frequencies ω_j . There are essentially two cases.

i) The frequencies ω_j are non-resonant, i.e., $k \cdot \omega \neq 0$ for all non-zero $k = (k_1, \dots, k_n)$, with k_j being integers (we write $k \in \mathbb{Z}^n$). Then each orbit is dense on this torus.

ii) The frequencies ω_j are resonant, that is, there exist integer relations $k \cdot \omega = 0$ for some non-zero $k \in \mathbb{Z}^n$. In this case each orbit is dense on some lower dimensional torus, but not in T^n .

We assume that the unperturbed system is non-degenerate in the sense that

$$\det \left| \frac{\partial^2 H_0}{\partial I_i \partial I_j} \right| \neq 0.$$

In this case the frequencies ω_j depend on the amplitudes, so they vary with the torus. This nonlinear frequency-amplitude relation is essential for the stability results of the KAM theory. It follows that the subset of non-resonant tori as well as that of resonant tori form dense subsets in phase space. Similar to the set of real numbers, the resonant tori sit among the non-resonant ones like the rational numbers among the irrational numbers.

Small Perturbations and KAM Theorem. Let us include now the small term $\varepsilon L_1(q, \dot{q})$ into the action functional and consider the perturbed variational problem. The first result, obtained already by Poincaré, showed that the resonant tori are in general destroyed by an arbitrarily small perturbation. In particular, out of a torus with an $n - 1$ -parameter family of periodic orbits, usually only finitely many periodic orbits survive a small perturbation, while the others disintegrate and give way to chaotic behavior. Since a set of resonant tori being destroyed by a small perturbation is dense among all invariant tori, there seems to be no hope for other tori to survive. In fact, until the middle of the 20th century it was a common belief that arbitrarily small perturbations can turn an integrable system into an ergodic one on each energy surface. By the way, it would not help if the non-degeneracy assumption is dropped. There exists a counter-example showing that if H_0 is too degenerate, the motion may even become ergodic on each energy surface, thus destroying all tori.

Kolmogorov [25] was the first to observe that, for the non-degenerate case, the converse is true: the majority of tori survives small perturbations. He gave the sketch of the proof about the persistence of those tori, whose frequencies ω_j are not only non-resonant, but are strongly non-resonant in the sense that there exist constants $\alpha > 0$ and $\nu > 0$ such that

$$|k \cdot \omega| \geq \frac{\alpha}{|k|^\nu} \tag{7.20}$$

for all non-zero $k \in \mathbb{Z}^n$, where $|k| = |k_1| + \dots + |k_n|$. Condition (7.20) is called a diophantine or small divisor condition. It turns out that the set of strongly non-resonant frequencies for any fixed $\nu > n - 1$ has the full measure, in contrast to the set of remaining frequencies having zero measure. But although almost all frequencies are

strongly non-resonant, it is not true that almost all tori survive a given perturbation εL_1 , no matter how small ε is. In its precise formulation, KAM theorem states that there exists a constant $\delta > 0$ such that for the perturbations of size $|\varepsilon| < \delta \alpha^2$ the strongly non-resonant tori of the unperturbed system persist, being only slightly deformed. Moreover, they depend continuously on ω and fill the phase space up to a set of measure $O(\alpha)$. An immediate consequence of the KAM theorem, important for the statistical mechanics, is that small perturbations of integrable systems do not necessarily imply ergodicity, as the invariant tori form a set, which is neither of full nor of zero measure. It has to be emphasized, however, that this invariant set, although of large measure, is a Cantor set and thus has no interior points. It is therefore impossible to tell with finite precision whether a given initial condition falls onto an invariant torus or into a gap between such tori. From a physical point of view the KAM theorem rather makes a probabilistic statement: with overwhelming probability of order $1 - O(\alpha)$ a randomly chosen orbit lies on an invariant torus and thus stays there forever.

Variational Problem for Invariant Tori. Since for an invariant torus with fixed frequencies ω the solution of Lagrange’s equations has the form $q(t) = u(\varphi_0 + \omega t)$, the generalized velocities may be written as

$$\dot{q} = \sum_{j=1}^n \omega_j \frac{\partial}{\partial \varphi_j} u = \nabla u,$$

where ∇ denotes the linear first order partial differential operator with constant coefficients

$$\nabla = \sum_{j=1}^n \omega_j \frac{\partial}{\partial \varphi_j}.$$

Therefore it is convenient to consider the following variational problem for an invariant torus, first mentioned in [39]: find extremals of the functional

$$I[u(\varphi)] = \int_0^{2\pi} \dots \int_0^{2\pi} L(u, \nabla u) d\varphi_1 \dots d\varphi_n = \int_{T^n} L(u, \nabla u) d\varphi \tag{7.21}$$

among vector-valued functions $u(\varphi) = (u_1(\varphi), \dots, u_n(\varphi))$ which are 2π -periodic in each variable φ_j . Euler-Lagrange’s equations of this variational problem read

$$\nabla L_{,\dot{q}}(u, \nabla u) - L_{,q}(u, \nabla u) = 0. \tag{7.22}$$

Thus, instead of solving the ordinary differential equations, we have to deal now with the nonlinear partial differential equations (7.22). Conversely, every solution $u(\varphi)$ of (7.22), 2π -periodic in each variable φ_j , determines the flow on some invariant torus which satisfies original Lagrange’s equations. We shall therefore apply the variational-asymptotic method to the variational problem (7.21). Then it is easy to see that the first step of the variational-asymptotic procedure leads to the unperturbed problem

$$\nabla L_{0,\dot{q}}(u, \nabla u) - L_{0,q}(u, \nabla u) = 0,$$

and, consequently, to the flow on the unperturbed invariant torus induced by the solution $u_0(\varphi)$ of this equation.

Second Step and Sketch of the Proof. In order to justify KAM theorem⁷ let us proceed to the second step of the variational-asymptotic method. We fix the solution of the unperturbed problem on some torus, $u_0(\varphi)$, and look for the extremal of (7.21) in the form

$$u(\varphi) = u_0(\varphi) + u_1(\varphi),$$

where $u_1(\varphi)$ is smaller than $u_0(\varphi)$ in the asymptotic sense. Substituting this into the action functional (7.21), expanding the Lagrangian in the Taylor series, and keeping the asymptotically principal terms containing u_1 , we obtain

$$\begin{aligned} I_1[u_1(\varphi)] &= \int_{T^n} [L_{,q}|_0 \cdot u_1 + L_{,\dot{q}}|_0 \cdot \nabla u_1 \\ &+ \frac{1}{2}(u_1 \cdot L_{,qq}|_0 u_1 + u_1 \cdot L_{,\dot{q}q}|_0 \nabla u_1 + \nabla u_1 \cdot L_{,q\dot{q}}|_0 u_1 + \nabla u_1 \cdot L_{,\dot{q}\dot{q}}|_0 \nabla u_1)] d\varphi. \end{aligned}$$

The vertical bar followed by index 0 means that the derivatives in front of it have to be evaluated at $(u_0(\varphi), \nabla u_0(\varphi))$. Thus, these first and second derivatives become functions of φ which are the coordinates on the torus. The obtained functional turns out to be quadratic with respect to u_1 . Its Euler-Lagrange's equation is linear and can be presented in the form

$$E(u_0) + dE(u_0)u_1 = 0, \quad (7.23)$$

where

$$E(u) = \nabla L_{,\dot{q}}(u, \nabla u) - L_{,q}(u, \nabla u), \quad (7.24)$$

and

$$dE(u_0)u_1 = \nabla(L_{,\dot{q}\dot{q}}|_0 \nabla u_1) + (L_{,\dot{q}q}|_0 - L_{,q\dot{q}}|_0) \nabla u_1 + (\nabla L_{,\dot{q}q}|_0 - L_{,qq}|_0) u_1. \quad (7.25)$$

It is interesting to mention that

$$dE(u)v = \frac{d}{d\lambda} E(u + \lambda v)|_{\lambda=0},$$

so equation (7.23) resembles Newton's iteration method of finding the root of a transcendental equation or the minimum of a function [41]. According to the variational-asymptotic method we can also replace L in (7.25) by L_0 which makes the error in determining u_1 of the order ε compared with 1. Since our aim is not computing u_1 , but just proving the existence of the solution, we keep (7.25) to be exactly as in Newton's iteration procedure.

⁷ See the rigorous and detailed proof in [46].

One of the difficulties in solving equation (7.23) comes from the linear operator ∇ in (7.25). Due to the small divisors, entering the representation of this operator with respect to the Fourier expansion of functions on the torus, its inverse is unbounded. Indeed, let us consider an equation $\nabla u = g$, where functions u and g are 2π periodic in each variable φ_j and can therefore be presented in terms of the Fourier series

$$u(\varphi) = \sum_{k \in \mathbb{Z}^n} u_k e^{ik \cdot \varphi}, \quad g(\varphi) = \sum_{k \in \mathbb{Z}^n} g_k e^{ik \cdot \varphi}.$$

Applying the operator ∇ to u , we get

$$\nabla u = \sum_{j=1}^n \omega_j \frac{\partial}{\partial \varphi_j} u = \sum_{k \in \mathbb{Z}^n} i(k \cdot \omega) u_k e^{ik \cdot \varphi},$$

so that the equation $\nabla u = g$ becomes

$$\sum_{k \in \mathbb{Z}^n} i(k \cdot \omega) u_k e^{ik \cdot \varphi} = \sum_{k \in \mathbb{Z}^n} g_k e^{ik \cdot \varphi}.$$

Even for non-resonant frequencies the combinations $k \cdot \omega$ may become arbitrarily small leading to the unbounded coefficients u_k of the series. The diophantine condition (7.20) has been introduced to remove infinitely small divisors. Now it is straightforward to show that for ω satisfying condition (7.20) and for every regular function $g(\varphi)$ with zero mean value, the equation $\nabla u = g$ has a unique solution with zero mean value. Indeed, since the Fourier series for $g(\varphi)$ converges, the coefficients g_k satisfy the following conditions

$$|g_k| \leq a\rho^{|k|}$$

with some positive a and $\rho < 1$. Besides, $g_0 = 0$ as $g(\varphi)$ has the zero mean value. Then $u_0 = 0$, $u_k = g_k / (ik \cdot \omega)$ and the Fourier series

$$u(\varphi) = \sum_{k \neq 0} \frac{g_k}{i(k \cdot \omega)} e^{ik \cdot \varphi}$$

clearly converges on account of the diophantine condition (7.20). The norm of $u(\varphi)$ can be precisely estimated.

But there are still two more obstacles to solving equation (7.23). First, the terms containing u_1 and ∇u_1 in equation (7.25) have to be eliminated. Then, the remaining second order partial differential equation requires a compatibility condition, namely that the inhomogeneous term $E(u_0)$ be of zero mean value. Note that these obstacles disappear in the special case when the identity map $u_0 = \varphi$ is an approximate solution of $E(u_0) = 0$. In this case it is easy to check that the coefficient matrices of u_1 and ∇u_1 in (7.25) are small and can be neglected. Indeed, the coefficient matrix of u_1 is the Jacobian matrix of $E(\varphi)$. For the estimation of the coefficient matrix of ∇u_1 we refer to the subsequent formula (7.29)₁. Therefore equation (7.23) can be replaced by

$$\nabla(L, \dot{q}\dot{q}|_0 \nabla u_1) = -E(\varphi)$$

and, by the above arguments, it can be solved since the right-hand side must always be of zero mean value. We conclude that, if the identity map $u_0 = \varphi$ is an approximate solution of $E(u_0) = 0$, then (7.23) admits an approximate solution u_1 so that the first step of the Newton iteration can be performed in this case.

Now the following idea allows us to reduce the general case to the one where u_0 is the identity map on the torus: let us try to *change* the Lagrangian so that the changed Euler-Lagrange's equation admits the identity map as solution. Consider the group of one-to-one maps $u(\varphi)$ of the torus which acts on the space of Lagrangians L according to the rule

$$u^*L(\varphi, v) = L(u(\varphi), Uv),$$

where $U(\varphi) = \partial u / \partial \varphi$ denotes the Jacobian matrix of u and is therefore 2π -periodic in each variable φ_j . Here u^*L is regarded as a function of the formal arguments φ and v , with v playing the role of the velocity. One verifies easily that

$$(u \circ v)^*L = u^*(v^*L), \quad id^*L = L,$$

where $(u \circ v)(\varphi) = u(v(\varphi))$ corresponds to the composition of two maps and id is the identity map $id = \varphi$. Functional (7.21) is compatible with this group action in the sense that

$$I_L[u \circ v(\varphi)] = I_{u^*L}[v(\varphi)],$$

and, moreover, it is invariant under the subgroup of translations. Since the Lagrangian may change, we attach it as the index to the functional. Taking the variation of the functionals standing on both sides, we find that

$$(U(v))^T E(L, u \circ v) = E(u^*L, v),$$

with $E(L, u)$ being the expression (7.24) where the Lagrangian is indicated precisely. Differentiating this equation with respect to v in the direction of a tangent vector w to the group of maps at $v = id$, we obtain

$$U^T dE(L, u)Uw = dE(u^*L, id)w - (dU \cdot w)^T E(L, u) \quad (7.26)$$

The previous equation with $v = id$ reduces to

$$U^T E(L, u) = E(u^*L, id). \quad (7.27)$$

It now follows from (7.27) that whenever u is an approximate solution of $E(L, u) = 0$ then also $E(u^*L, id)$ is small and hence the above considerations about the case $u = id$ show that there exists an approximate solution w of the equation $dE(u^*L, id)w = -E(u^*L, id)$. Combining this observation with the identities (7.26) and (7.27), we conclude that equation (7.23) indeed has an approximate solution $u_1 = U_0 w$ in the sense that errors of quadratic order are ignored.

The precise estimation for the approximate solution of the linearized equation (7.23) are based on several formulas which are summarized below. First,

$$U^T dE(L, u)Uw = \nabla(A\nabla w) + B\nabla w + Cw, \quad (7.28)$$

where A , B , and C are the $n \times n$ matrix-valued functions on T^n defined by

$$A = U^T L_{,v\nu} U, \quad B = U^T L_{,v\varphi} - L_{,v\varphi}^T U, \quad C = U^T E_{,\varphi},$$

and the following abbreviations are used

$$L_{,v\varphi} = \frac{\partial}{\partial \varphi} L_{,v}(u(\varphi), \nabla u(\varphi)), \quad E_{,\varphi} = \frac{\partial}{\partial \varphi} E(L, u), \quad U = \frac{\partial u}{\partial \varphi}.$$

Formula (7.28) follows from equation (7.26) by inserting the expression (7.25) with L and u_1 replaced by u^*L and w , respectively. Then we have

$$\begin{aligned} \nabla B &= C - C^T, \\ \int_{T^n} B d\varphi &= 0, \\ \int_{T^n} U^T E(L, u) d\varphi &= 0. \end{aligned} \quad (7.29)$$

Formula (7.29)₁ expresses the fact, well known in variational calculus, that the operator

$$Mw = \nabla(A\nabla w) + B\nabla w + Cw,$$

which represents the Hessian of the functional (7.21), is self-adjoint. Indeed, since $A^T = A$ and $B^T = -B$, the adjoint operator of M is given by

$$M^*w = \nabla(A^T \nabla w) - \nabla(B^T w) + C^T w = \nabla(A\nabla w) + B\nabla w + (C^T + \nabla B)w$$

so that $M^* = M$ if and only if $C^T + \nabla B = C$.

The last two formulas reflect the fact that the functional $I[u(\varphi)]$ defined by (7.21) is invariant under the subgroup of translations of the torus T^n (see exercise 7.9).

It follows from these formulas that if u is a solution of $E(L, u) = 0$ and the frequency vector ω is rationally independent then $C = 0$ and $B = 0$. Indeed, since $\nabla B = 0$ the function $B(\varphi)$ is constant along the dense line $\varphi = \omega t$. Hence it is constant on T^n and it follows from (7.29)₂ that $B = 0$. As a consequence the linearized operator is given by

$$U^T dE(L, u)Uw = \nabla(A\nabla w)$$

which is invertible.

Provided u_1 can be found and the error we make can be estimated, we now replace u_0 by $u_0 + u_1$ and *repeat* the second step of the variational-asymptotic procedure to find the next correction. This is the crucial idea of Newton's iteration leading to the fast convergence. It can simply be shown in the case of finding roots of transcendental equations that if the initial error is ε , then the error after n iteration would be of the order ε^{2^n} . Such fast convergence, valid also for (7.23) as shown in [46], may remove the errors induced by the small divisors at each iteration and guarantees the convergence to the solution of variational problem (7.21).

7.4 Coupled Self-excited Oscillators

As we know, a self-excited oscillator, such as van der Pol's oscillator, may generate a limit cycle periodic vibration with a fixed frequency. What happens if two slightly different self-excited oscillators are coupled? One may imagine for instance two violins playing near each other and interacting through the sound wave, or two Froude's pendulums connected by a weak spring. Another example is two pendulum clocks which move into the same swinging rhythm when they are hung near each other on the wall. Although uncoupled oscillators have in general different frequencies, the effect of the coupling may lead to a vibration which is phase and frequency locked, or in another word, to synchronization.⁸

Two Weakly Coupled van der Pol's Oscillators. We will study the synchronization of two weakly coupled van der Pol's oscillators, whose Lagrange function is given by

$$L(x, y, \dot{x}, \dot{y}) = \frac{1}{2}(\dot{x}^2 + \dot{y}^2) - \frac{1}{2}[x^2 + (1 + \varepsilon\alpha)y^2 + \varepsilon\kappa(x - y)^2],$$

where ε is a small parameter, parameter α characterizes the difference in uncoupled frequencies, while κ is a coupling factor. Since we are interested in the primary resonance, we order the amplitude of the coupling to be the same as the damping and non-linear term [10]. Thus, the dissipation function assumes the form

$$D(x, y, \dot{x}, \dot{y}) = \frac{1}{2}\varepsilon[(x^2 - 1)\dot{x}^2 + (y^2 - 1)\dot{y}^2].$$

Then $x(t)$ and $y(t)$ satisfy the variational equation

$$\delta \int_{t_0}^{t_1} L(x, y, \dot{x}, \dot{y}) dt - \int_{t_0}^{t_1} \left(\frac{\partial D}{\partial \dot{x}} \delta \dot{x} + \frac{\partial D}{\partial \dot{y}} \delta \dot{y} \right) dt = 0.$$

Generalized Lagrange's equations read [10]

$$\begin{aligned} \ddot{x} + x + \varepsilon\kappa(x - y) - \varepsilon(1 - x^2)\dot{x} &= 0, \\ \ddot{y} + (1 + \varepsilon\alpha)y - \varepsilon\kappa(x - y) - \varepsilon(1 - y^2)\dot{y} &= 0. \end{aligned} \tag{7.30}$$

We need to find the asymptotic behavior of solution in the limit $\varepsilon \rightarrow 0$.

When $\kappa = 0$ the system (7.30) is uncoupled and the two equations exhibit unsynchronized limit cycle vibrations for $x(t)$ and $y(t)$ with different frequencies 1 and $\sqrt{1 + \varepsilon\alpha}$. When κ is small, then we may expect by the continuity reasoning that the vibrations are still unsynchronized. For finite κ we may have three states of a coupled self-organized oscillator: strongly locked, weakly locked, and unlocked. The vibration is said to be strongly locked (or strongly synchronized) if it is both frequency and phase locked. If the vibration is frequency locked but the relative phase

⁸ The earliest known observation of synchronization was made by Huygens. He reported that "two clocks, hanging side by side and separated by one or two feet, keep between them a consonance so exact that the two pendula always strike together, never varying".

changes slowly with time, it is called weakly locked (or weakly synchronized). If the frequencies of vibration are different, the system is said to be unlocked or drifting.

Numerical Solutions. The system of equations (7.30) does not admit exact analytical solutions. So, in order to observe the behavior of solutions and to illustrate the difference between synchronized and unsynchronized vibrations let us first do some numerical simulations.

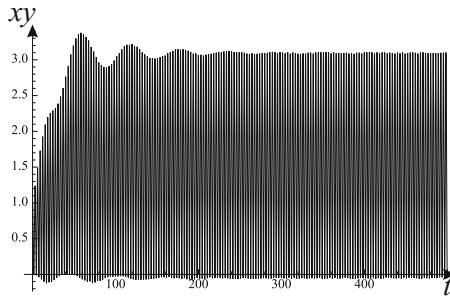

Fig. 7.12 Graph $x(t)y(t)$ of coupled van der Pol's oscillators for $\epsilon = 0.1$, $\alpha = 1$, and $\kappa = 1.2$

We take for example $\epsilon = 0.1$, $\alpha = 1$, and $\kappa = 1.2$ and find the solution to (7.30) satisfying the initial conditions $x(0) = 1$, $\dot{x}(0) = 0$ and $y(0) = 1$, $\dot{y}(0) = 0$ by the numerical integration with *Mathematica*. The plot of the product $x(t)y(t)$ shown in Fig. 7.12 exhibits obviously synchronization in this case. Indeed, since $x(t)$ and $y(t)$ approach periodic (for small ϵ harmonic) functions with the same frequency and constant phase difference, their product must have a steady-state character after a short transient period.

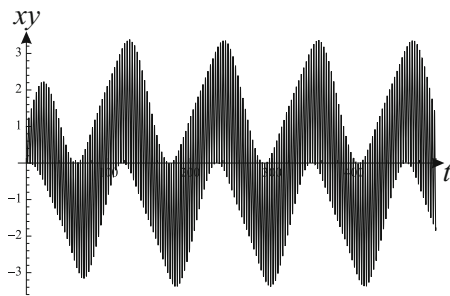

Fig. 7.13 Graph $x(t)y(t)$ of coupled van der Pol's oscillators for $\epsilon = 0.1$, $\alpha = 1$, and $\kappa = 0.5$

If we decrease the coupling factor while keeping all other parameters and initial data, the response may change drastically. For example, the plot of the product $x(t)y(t)$ for $\kappa = 0.5$ shown in Fig. 7.13 does not indicate vibrations of $x(t)$ and $y(t)$

with equal frequency and constant phase difference. Thus, in this case synchronization does not occur, and the system is unlocked.

In the next paragraph we will use the variational-asymptotic method to establish the law of slow change of amplitudes and phases as function of the frequency difference and the coupling parameter and to predict the synchronization.

Variational-Asymptotic Method. Let us introduce the frequency ω of vibration precisely into the variational equation by multiplying it with ω and rewriting in terms of the stretched angular time $\tau = \omega t$ for one fix period 2π

$$\begin{aligned} \delta \int_{\tau_0}^{\tau_0+2\pi} \left\{ \frac{1}{2} \omega^2 (x'^2 + y'^2) - \frac{1}{2} [x^2 + (1 + \varepsilon \alpha) y^2 + \varepsilon \kappa (x - y)^2] \right\} d\tau \\ + \int_{\tau_0}^{\tau_0+2\pi} \varepsilon \omega [(1 - x^2) x' \delta x + (1 - y^2) y' \delta y] d\tau = 0, \end{aligned} \quad (7.31)$$

where prime denotes the derivative with respect to τ and τ_0 is an arbitrary time instant. We write for short $\tau_0 = 0$.

We put at the first step $\varepsilon = 0$ to obtain

$$\delta \int_0^{2\pi} \left[\frac{1}{2} \omega^2 (x'^2 + y'^2) - \frac{1}{2} (x^2 + y^2) \right] d\tau = 0.$$

The 2π -periodic extremal is

$$x_0 = A_1 \cos \tau + B_1 \sin \tau, \quad y_0 = A_2 \cos \tau + B_2 \sin \tau, \quad (7.32)$$

for which the frequency ω is equal to 1 as expected.

As soon as $\varepsilon \neq 0$ the coefficients A_1, B_1, A_2, B_2 are becoming slightly dependent on time and ω deviates from 1. Therefore we look for the extremal and for the frequency at the second step in the form

$$\begin{aligned} x &= A_1(\eta) \cos \tau + B_1(\eta) \sin \tau + x_1(\tau, \eta), \\ y &= A_2(\eta) \cos \tau + B_2(\eta) \sin \tau + y_1(\tau, \eta), \quad \omega = 1 + \omega_1, \end{aligned}$$

where $\eta = \varepsilon \tau$ is the slow time. We assume that $x_1(\tau, \eta)$ and $y_1(\tau, \eta)$ are 2π -periodic functions with respect to the fast time τ and are much smaller than x_0 and y_0 in the asymptotic sense, and ω_1 is much smaller than 1. Note that the asymptotically principal terms of the derivatives of x and y are

$$x' = x_{0,\tau} + \varepsilon x_{0,\eta} + x_{1,\tau}, \quad y' = y_{0,\tau} + \varepsilon y_{0,\eta} + y_{1,\tau},$$

where the comma in indices denotes the partial derivatives. Substituting x, y together with their derivatives into functional (7.31) and keeping the principal terms of x_1, y_1 and the principal cross terms between x_0, y_0 and x_1, y_1 we have

$$\begin{aligned} \delta \int_0^{2\pi} \{ & \frac{1}{2}x_{1,\tau}^2 + \frac{1}{2}y_{1,\tau}^2 + \underline{x_{0,\tau}x_{1,\tau}} + \underline{\varepsilon x_{0,\eta}x_{1,\tau}} + \underline{2\omega_1 x_{0,\tau}x_{1,\tau}} + \underline{y_{0,\tau}y_{1,\tau}} + \underline{\varepsilon y_{0,\eta}y_{1,\tau}} \\ & + \underline{2\omega_1 y_{0,\tau}y_{1,\tau}} - (\frac{1}{2}x_1^2 + \frac{1}{2}y_1^2 + \underline{x_0 x_1} + \underline{y_0 y_1}) - \varepsilon[\alpha y_0 y_1 + \kappa(x_0 - y_0)(x_1 - y_1) \\ & - (1 - x_0^2)x_{0,\tau}x_1 - (1 - y_0^2)y_{0,\tau}y_1] \} d\tau = 0. \end{aligned}$$

Integrating the third up to eighth terms by parts using the periodicity of x_1 and y_1 with respect to τ , we see that the underlined terms gives $-2\varepsilon(x_{0,\tau\eta}x_1 + y_{0,\tau\eta}y_1) + 2\omega_1(x_0x_1 + y_0y_1)$. Then, substituting the expressions for x_0 and y_0 into the functional and reducing the products of sine and cosine to the sum of harmonic functions, we get the resonant terms which should be removed in order to be consistent with the above asymptotic expansion. This implies that ω_1 must be of the order ε ; let us denote it by $\omega_1 = \varepsilon k_1$. The equations obtained for A_1, B_1, A_2, B_2 read⁹

$$\begin{aligned} 2A_{1,\eta} &= -2k_1B_1 + A_1 - \frac{A_1}{4}(A_1^2 + B_1^2) + \kappa(B_1 - B_2), \\ 2B_{1,\eta} &= 2k_1A_1 + B_1 - \frac{B_1}{4}(A_1^2 + B_1^2) + \kappa(A_2 - A_1), \\ 2A_{2,\eta} &= -2k_1B_2 + \alpha B_2 + A_2 - \frac{A_2}{4}(A_2^2 + B_2^2) + \kappa(B_2 - B_1), \\ 2B_{2,\eta} &= 2k_1A_2 - \alpha A_2 + B_2 - \frac{B_2}{4}(A_2^2 + B_2^2) + \kappa(A_1 - A_2). \end{aligned}$$

This system of equations can still be simplified if we introduce the amplitudes and phases of vibrations in accordance with

$$\begin{aligned} A_1 &= a_1 \cos \phi_1, & B_1 &= a_1 \sin \phi_1, \\ A_2 &= a_2 \cos \phi_2, & B_2 &= a_2 \sin \phi_2. \end{aligned}$$

Thus, a_1 and a_2 characterize the amplitudes of x_0 and y_0 , respectively, while ϕ_1 and ϕ_2 are the corresponding phases.

In terms of the new variables the equations that result from the elimination of the resonant terms can be written as

$$\begin{aligned} 2a_{1,\eta} &= a_1(1 - \frac{a_1^2}{4}) + \kappa a_2 \sin(\phi_1 - \phi_2), \\ 2a_{2,\eta} &= a_2(1 - \frac{a_2^2}{4}) - \kappa a_1 \sin(\phi_1 - \phi_2), \\ 2\phi_{1,\eta} &= 2k_1 - \kappa + \frac{\kappa a_2 \cos(\phi_1 - \phi_2)}{a_1}, \\ 2\phi_{2,\eta} &= 2k_1 - \alpha - \kappa + \frac{\kappa a_1 \cos(\phi_1 - \phi_2)}{a_2}. \end{aligned}$$

⁹ One may check this with the TrigReduce command in *Mathematica*.

Introducing the phase difference $\varphi = \phi_1 - \phi_2$, we reduce this system further to three differential equations governing the slow change of amplitudes and phase difference

$$\begin{aligned} 2a_{1,\eta} &= a_1\left(1 - \frac{a_1^2}{4}\right) + \kappa a_2 \sin \varphi, \\ 2a_{2,\eta} &= a_2\left(1 - \frac{a_2^2}{4}\right) - \kappa a_1 \sin \varphi, \\ 2\varphi_{,\eta} &= \alpha + \kappa \cos \varphi \left(\frac{a_2}{a_1} - \frac{a_1}{a_2}\right). \end{aligned} \quad (7.33)$$

After finding the amplitudes and phase difference from (7.33), we can find k_1 from the previous equation for ϕ_1 by setting $\phi_1 = 0$. This is possible since the original system is autonomous.

The Slow Flow. Let us seek fixed points of the slow flow (7.33) representing synchronized vibrations of the coupled oscillators. We multiply the first equation of (7.33) (with the zero left-hand side) by a_1 and the second by a_2 and add together to get

$$a_1^2 + a_2^2 - \frac{a_1^4 + a_2^4}{4} = 0. \quad (7.34)$$

Next, multiplying the first equation of (7.33) by a_2 and the second by a_1 and subtracting them to obtain

$$\sin \varphi = \frac{a_1 a_2 (a_1^2 - a_2^2)}{4\kappa(a_1^2 + a_2^2)}.$$

From the third equation of (7.33) with $\varphi_{,\eta} = 0$ on the left-hand side follows

$$\cos \varphi = \frac{\alpha a_1 a_2}{\kappa(a_1^2 - a_2^2)}.$$

Using the identity $\sin^2 + \cos^2 = 1$ and setting

$$p = a_1^2 + a_2^2, \quad q = a_1^2 - a_2^2,$$

we get from the two last equations

$$q^6 - p^2 q^4 + (16\alpha^2 + 64\kappa^2)p^2 q^2 - 16\alpha^2 p^4 = 0.$$

In terms of p, q , equation (7.34) becomes

$$q^2 = 8p - p^2.$$

Substituting this equation into the previous one, we obtain finally

$$p^3 - 20p^2 + (16\alpha^2 + 32\kappa^2 + 128)p - (64\alpha^2 + 256\kappa^2 + 256) = 0. \quad (7.35)$$

This cubic equation has either 1 or 3 positive roots for p . At bifurcation, there will be a double root which appears if the derivative of (7.35) vanishes

$$3p^2 - 40p + 16\alpha^2 + 32\kappa^2 + 128 = 0. \tag{7.36}$$

Eliminating p from (7.35) and (7.36) gives the condition for saddle-node bifurcations as

$$\alpha^6 + (6\kappa^2 + 2)\alpha^4 + (12\kappa^4 - 10\kappa^2 + 1)\alpha^2 + 8\kappa^6 - \kappa^4 = 0. \tag{7.37}$$

Equation (7.37) plots as two curves intersecting as a cusp in the (α, κ) -plane (see Fig. 7.14). At the cusp, a further degeneracy occurs and there is a triple root of equation (7.35). Requiring the derivative of (7.36) to vanish yields $p = 20/3$ at the cusp, which gives the location of the cusp as

$$\alpha = \frac{1}{\sqrt{27}} \approx 0.1924, \quad \kappa = \frac{2}{\sqrt{27}} \approx 0.3849.$$

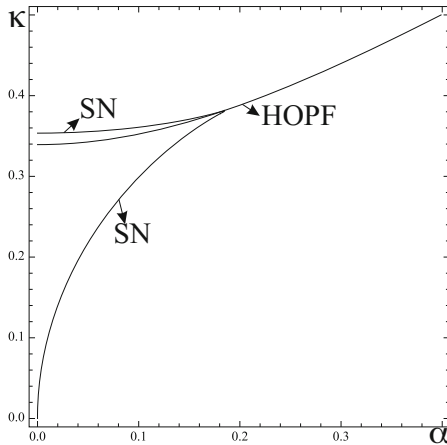

Fig. 7.14 Saddle-node and Hopf’s bifurcation of coupled van der Pol’s oscillator

Next, we look for Hopf’s bifurcations of the slow flow (7.33). The presence of a stable limit cycle surrounding an unstable fixed point, as occurs in a supercritical Hopf’s bifurcation, means a weakly locked quasiperiodic motion of the original system (7.30). Let $(a_{10}, a_{20}, \varphi_0)$ be a fixed point. The behavior of the system (7.33) linearized in the neighborhood of this point is determined by the eigenvalues of the Jacobian matrix

$$\frac{1}{2} \begin{pmatrix} -\frac{3a_{10}^2 - 4}{4} & \kappa \sin \varphi_0 & \kappa \cos \varphi_0 a_{20} \\ -\kappa \sin \varphi_0 & -\frac{3a_{20}^2 - 4}{4} & -\kappa \cos \varphi_0 a_{10} \\ -\frac{\kappa \cos \varphi_0 (a_{10}^2 + a_{20}^2)}{a_{10} a_{20}} & \frac{\kappa \cos \varphi_0 (a_{10}^2 + a_{20}^2)}{a_{10} a_{20}} & -\frac{\kappa \sin \varphi_0 (a_{20}^2 - a_{10}^2)}{a_{10} a_{20}} \end{pmatrix}.$$

Using the above relations between a_1 , a_2 , $\sin \varphi$, $\cos \varphi$ and p , q , we can express the elements of this matrix in terms of p . The eigenvalues of this matrix are the roots of the cubic equation

$$\lambda^3 + c_2\lambda^2 + c_1\lambda + c_0 = 0,$$

where

$$\begin{aligned} c_2 &= \frac{p-4}{2}, \\ c_1 &= \frac{7p^3 - 112p^2 + (-16\alpha^2 + 512)p - 512}{64p - 512}, \\ c_0 &= \frac{p^4 - 22p^3 + 160p^2 - (32\alpha^2 + 384)p}{128p - 1024}. \end{aligned}$$

For a Hopf bifurcation to occur, the eigenvalues λ must include a pair of imaginary roots, $\pm i\beta$, and a real eigenvalue, γ . This requires the characteristic equation to have the form

$$\lambda^3 - \gamma\lambda^2 + \beta^2\lambda - \beta^2\gamma = 0.$$

Comparing these cubic equations, we see that a necessary condition for Hopf's bifurcation to occur is

$$c_0 = c_1c_2 \Rightarrow 3p^4 - 59p^3 + (-8\alpha^2 + 400)p^2 + (48\alpha^2 - 1088)p + 1024 = 0.$$

Eliminating p between this equation and (7.35) yields the condition for Hopf's bifurcation as

$$\begin{aligned} 49\alpha^8 + (266\kappa^2 + 238)\alpha^6 + (88\kappa^4 + 758\kappa^2 + 345)\alpha^4 + (-1056\kappa^6 \\ + 1099\kappa^4 + 892\kappa^2 + 172)\alpha^2 - 1152\kappa^8 - 2740\kappa^6 - 876\kappa^4 + 16 = 0. \end{aligned}$$

This equation plots as a curve in the (α, κ) -plane, which intersect the lower curve of saddle node bifurcation at point P and touches the upper curve of saddle-node bifurcation at point Q with the coordinates (see Fig. 7.15)

$$P: \alpha \approx 0.1918, \kappa \approx 0.3846, \quad Q: \alpha \approx 0.1899, \kappa \approx 0.3837.$$

We see that the main features of saddle-node and Hopf's bifurcations of a coupled van der Pol's oscillator are quite similar to those of forced van der Pol's oscillator discussed in Section 6.3. Strong synchronization occurs everywhere in the first quadrant of the (α, κ) -plane except in that region bounded by i) the lower curve of saddle node bifurcations from the origin to point P, ii) the curve of Hopf bifurcation from point P to infinity, and iii) the α -axis. However, there is an additional bifurcation here which did not occur in the forced problem. There is a homoclinic bifurcation which occurs along a curve emanating from point Q. This involves the destruction of the limit cycle which was born in the Hopf bifurcation. The limit cycle grows in size until it gets so large that it hits a saddle, and disappears in a saddle connection (see the details and further references in [10, 43]).

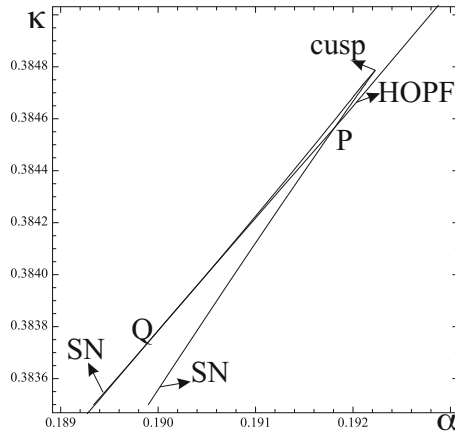

Fig. 7.15 Blowup of cusp region

In summary, we see that the transition from strongly synchronized vibrations to drifted vibrations involves an intermediate state in which the system is weakly synchronized. In the three-dimensional slow flow space, we go from a stable fixed point (strongly locked), to a stable limit cycle (weakly locked), and finally to a periodic motion which is topologically distinct from the original limit cycle (unlocked). As in the case of forced van der Pol’s oscillator, in order for the strong synchronization to occur, we need either a small difference in uncoupled frequencies (small α) or a strong interaction of oscillators guaranteed by a large coupling factor κ .

7.5 Exercises

EXERCISE 7.1. Derive the equations of nonlinear vibration of the double pendulum considered in exercise 2.1.

Solution. Let us find the exact formula for the kinetic energy of the point-mass m_2 . As seen from Fig. 2.14, the cartesian coordinates of this point-mass are

$$x_2 = l_1 \cos \varphi_1 + l_2 \cos \varphi_2, \quad y_2 = l_1 \sin \varphi_1 + l_2 \sin \varphi_2.$$

Thus, the kinetic energy of m_2 equals

$$K_2 = \frac{1}{2}m_2(\dot{x}_2^2 + \dot{y}_2^2) = \frac{1}{2}m_2[l_1^2 \dot{\varphi}_1^2 + l_2^2 \dot{\varphi}_2^2 + 2l_1 l_2 \cos(\varphi_1 - \varphi_2) \dot{\varphi}_1 \dot{\varphi}_2].$$

Taking the kinetic energy of m_1 and the potential energy of the point-masses as in the solution of the exercise 2.1, we obtain the exact Lagrange function in the form

$$L = \frac{1}{2}(m_1 + m_2)l_1^2\dot{\varphi}_1^2 + \frac{1}{2}m_2l_2^2\dot{\varphi}_2^2 + m_2l_1l_2\cos(\varphi_1 - \varphi_2)\dot{\varphi}_1\dot{\varphi}_2 \\ + (m_1 + m_2)gl_1\cos\varphi_1 + m_2gl_2\cos\varphi_2.$$

After some simple transformations we obtain from Lagrange's equations

$$\ddot{\varphi}_1 + \alpha\cos(\varphi_1 - \varphi_2)\ddot{\varphi}_2 + \alpha\sin(\varphi_1 - \varphi_2)\dot{\varphi}_2^2 + \frac{g}{l_1}\sin\varphi_1 = 0, \\ \ddot{\varphi}_2 + \beta\cos(\varphi_1 - \varphi_2)\ddot{\varphi}_1 - \beta\sin(\varphi_1 - \varphi_2)\dot{\varphi}_1^2 + \frac{g}{l_2}\sin\varphi_2 = 0,$$

where

$$\alpha = \frac{m_2l_2}{(m_1 + m_2)l_1}, \quad \beta = \frac{l_1}{l_2}.$$

EXERCISE 7.2. Hamilton-Jacobi equation. Let the action function $S(q, t)$ be defined as the integral

$$S_{q_0, t_0}(q, t) = \int_{\gamma} L dt$$

along the extremal γ connecting the points (q_0, t_0) and (q, t) . Show that $S(q, t)$ satisfies the Hamilton-Jacobi equation

$$\frac{\partial S}{\partial t} + H\left(q, \frac{\partial S}{\partial q}\right) = 0.$$

Solution. Let us first fix the time instant t and consider different extremals ending at different points q . Calculating the variation of S we get

$$\delta S = \frac{\partial L}{\partial \dot{q}} \cdot \delta q \Big|_{t_0}^t + \int_{t_0}^t \left(\frac{\partial L}{\partial q} - \frac{d}{dt} \frac{\partial L}{\partial \dot{q}} \right) \cdot \delta q dt = 0.$$

The second term vanishes because the variation is taken along the extremals satisfying Lagrange's equations. The first term, evaluated at the lower limit t_0 is also zero because q_0 is fixed. Replacing $\partial L / \partial \dot{q}$ by p , we obtain

$$\delta S = p \cdot \delta q,$$

and, consequently

$$\frac{\partial S}{\partial q} = p.$$

Now we let also t change. Then, it follows from the definition of S that its total time derivative equals L

$$\frac{dS}{dt} = L.$$

Using the chain rule of differentiation we have

$$\frac{dS}{dt} = \frac{\partial S}{\partial t} + \frac{\partial S}{\partial q} \cdot \dot{q} = \frac{\partial S}{\partial t} + p \cdot \dot{q}.$$

Thus,

$$\frac{\partial S}{\partial t} = L - p \cdot \dot{q} = -H(q, p).$$

Substituting $p = \partial S / \partial q$ into the Hamilton function and bringing $-H$ to the left-hand side, we obtain the Hamilton-Jacobi equation.

EXERCISE 7.3. Find the action variable for the Duffing oscillator with

$$H(q, p) = \frac{1}{2}(p^2 + U(q)), \quad U = U(q) = \frac{1}{2}q^2 + \frac{1}{4}\alpha q^4.$$

Solution. According to the definition of the action variable

$$I = \frac{1}{2\pi} \oint pdq.$$

We use the exact solution (5.12) of the Duffing equation to evaluate the contour integral. Since $p = \dot{q}$ and $dq = \dot{q}dt$ and since the phase curve is symmetric about the q - and \dot{q} -axes we have

$$\oint pdq = 4 \int_0^{q_M} pdq = 4 \int_0^{T/4} \dot{q}^2 dt.$$

Now we substitute the solution (5.12) into this integral. Since

$$q(t) = a \operatorname{cn}(bt, m), \quad \dot{q} = -ab \operatorname{sn}(bt, m) \operatorname{dn}(bt, m),$$

where

$$b = \sqrt{1 + \alpha a^2}, \quad m = \frac{\alpha a^2}{2(1 + \alpha a^2)},$$

the integral becomes

$$\oint pdq = 4 \int_0^{T/4} \dot{q}^2 dt = 4a^2 b^2 \int_0^{T/4} \operatorname{sn}^2(bt, m) \operatorname{dn}^2(bt, m) dt.$$

Changing the variable t to $u = bt$ and taking into account that $bT/4 = K(m)$, we get

$$\oint pdq = 4a^2 b \int_0^{K(m)} \operatorname{sn}^2(u, m) \operatorname{dn}^2(u, m) du.$$

This integral of Jacobian elliptic functions can be computed analytically.¹⁰ The result is

$$\oint pdq = 4a^2 b \frac{(-1 + 2m)E(m) + (1 - m)K(m)}{3m},$$

where $K(m)$ and $E(m)$ are the complete elliptic integrals of the first and second kind, respectively. Thus, the action variable equals

¹⁰ Use the formulas given in 5.13 of [3] or the symbolic integration with *Mathematica*.

$$I = \frac{2a^2b}{\pi} \frac{(-1+2m)E(m) + (1-m)K(m)}{3m}.$$

The total energy of the Duffing oscillator depends on the amplitude a as follows

$$H = \frac{1}{2}a^2 + \frac{1}{4}\alpha a^4.$$

Using the properties of the complete elliptic integrals one can show that

$$\frac{dI}{da} = \frac{2abK(m)}{\pi}.$$

Therefore

$$\frac{dH}{dI} = \frac{dH/da}{dI/da} = \frac{a(1+a^2)\pi}{2abK(m)} = \frac{\pi b}{2K(m)} = \frac{2\pi}{T} = \omega(a).$$

EXERCISE 7.4. Simulate numerically the Poincaré map for the Hénon-Heiles equations which can be obtained as Lagrange's equation of the following Lagrange function

$$L = \frac{1}{2}(\dot{x}^2 + \dot{y}^2) - \frac{1}{2}(x^2 + y^2 + 2x^2y - \frac{2}{3}y^3).$$

Choose the cut plane $x = 0$ and the total energy i) $E_0 = 0.01$ and ii) $E_0 = 1/8$. Observe the difference in cases i) and ii).

Solution. Let us derive the equations of motion of these coupled oscillators in the Hamilton's form. Denoting $q_1 = x$, $q_2 = y$ and introducing $p_1 = \dot{q}_1$, $p_2 = \dot{q}_2$, we transform the above Lagrange function to the Hamilton function

$$H = \frac{1}{2}(p_1^2 + p_2^2) + \frac{1}{2}(q_1^2 + q_2^2 + 2q_1^2q_2 - \frac{2}{3}q_2^3).$$

Hamilton's equations are

$$\begin{aligned} \dot{q}_1 &= p_1, & \dot{p}_1 &= -(q_1 + 2q_1q_2), \\ \dot{q}_2 &= p_2, & \dot{p}_2 &= -(q_2 - q_2^2 + q_1^2). \end{aligned}$$

This dynamical system has one stable fixed point at the origin $(0, 0)$ and three unstable fixed points given by

$$P_1 : (0, 1), \quad P_2 : (\sqrt{3}/2, -1/2), \quad P_3 : (-\sqrt{3}/2, -1/2).$$

The contour plot of the potential energy $U(q) = \frac{1}{2}(q_1^2 + q_2^2 + 2q_1^2q_2 - \frac{2}{3}q_2^3)$ is shown in Fig. 7.16. The separatrices connecting the unstable fixed points are straight lines and correspond to the energy level $1/6$. All contours with the potential energies less than $1/6$ are inside the triangle $P_1P_2P_3$.

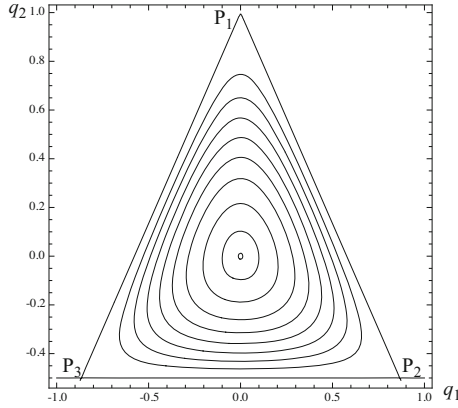

Fig. 7.16 Contour plot of the potential energy of Henon-Heiles oscillators

As the dynamical system of Henon-Heiles oscillators is conservative, the energy conservation reads

$$H(q, p) = E_0,$$

and the phase curves having the initial energy E_0 must lie on some 3-D energy level surface. We use this integral to find p_1 . Then the phase curves must be found in some 3-D space of parameters q_1, q_2, p_2 . To follow the traces of these phase curves we choose the cut plane $q_1 = 0$ and plot the Poincaré map numerically using the code written by Weinstein. The results are shown in Fig. 7.17 for the case $E_0 = 10^{-2}$ (left) and $E_0 = 1/8$ (right), respectively. For $E_0 = 10^{-2}$ we see four families of embedded tori corresponding to ordered motion. For $E_0 = 1/8$ one observes a chaotic sea surrounding small islands of ordered motion.

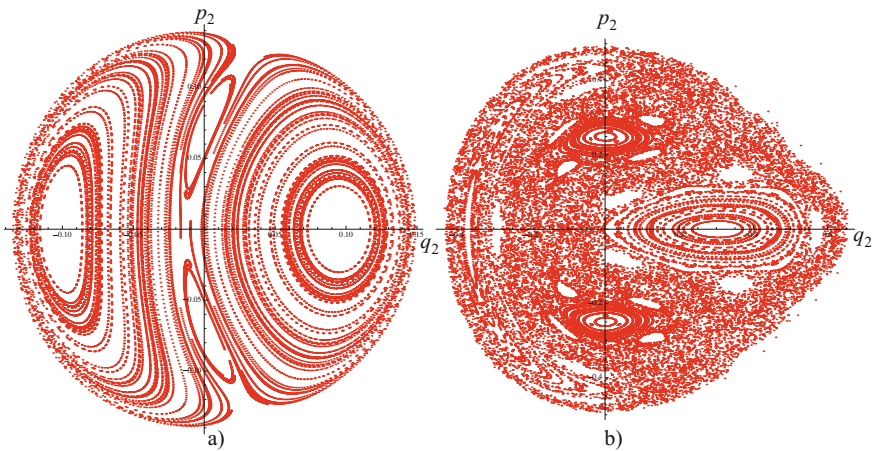

Fig. 7.17 Poincaré maps of Henon-Heiles oscillators: a) $E_0 = 0.01$, b) $E_0 = 1/8$

EXERCISE 7.5. Modal equation in a rotating frame. In the frame rotating with the constant angular velocity ω , the presence of Coriolis and centripetal accelerations changes the equations of motion (7.7) to

$$\ddot{x} - 2\omega\dot{y} - \omega^2x = -\frac{\partial U}{\partial x}, \quad \ddot{y} + 2\omega\dot{x} - \omega^2y = -\frac{\partial U}{\partial y}.$$

For this system, obtain a first integral and use it to derive a modal equation for the orbits in the (x, y) -plane which does not involve time t .

Solution. The first integral can easily be obtained if we know the kinetic and potential energies. The absolute velocity of the point-mass equals

$$\mathbf{v} = \mathbf{v}_l + \mathbf{v}_r,$$

where $\mathbf{v}_l = \boldsymbol{\omega} \times \mathbf{r} = (-\omega y, \omega x)$ is the instantaneous velocity of the point-mass rotating together with the frame about the z -axis and $\mathbf{v}_r = (\dot{x}, \dot{y})$ the relative velocity. Thus,

$$\mathbf{v} = (\dot{x} - \omega y, \dot{y} + \omega x),$$

and the kinetic energy for $m = 1$ becomes

$$K = \frac{1}{2}[(\dot{x} - \omega y)^2 + (\dot{y} + \omega x)^2].$$

Together with the potential energy $U(x, y)$, the conservation of the total energy reads

$$\frac{1}{2}[(\dot{x} - \omega y)^2 + (\dot{y} + \omega x)^2] + U(x, y) = E_0.$$

We seek the nonlinear normal modes as periodic solutions by assuming y as a function of x , without direct reference to time t , and try to eliminate t in these equations. Using the chain rule

$$\dot{y} = y'\dot{x}, \quad \ddot{y} = y''\dot{x}^2 + y'\ddot{x},$$

with prime denoting the derivative of y with respect to x , and substituting this into the Lagrange equation for y to get

$$-\frac{\partial U}{\partial y} = y''\dot{x}^2 + y'(2\omega y'\dot{x} + \omega^2x - \frac{\partial U}{\partial x}) - 2\omega\dot{x} - \omega^2y.$$

Next, we plug \dot{y} into the energy conservation

$$\frac{1}{2}[\dot{x}^2(1 + y'^2) + 2\omega(xy' - y)\dot{x} + \omega^2(x^2 + y^2)] + U(x, y) = E_0.$$

Solving this equation with respect to \dot{x} , we obtain

$$\dot{x} = \frac{-\omega(xy' - y) \pm \sqrt{\omega^2(xy' - y)^2 - (1 + y'^2)[\omega^2(x^2 + y^2) + 2U(x, y) - 2E_0]}}{1 + y'^2}.$$

Substituting this formula into the above equation, we derive the nonlinear modal equation in terms of $y(x)$.

EXERCISE 7.6. A rigid bar, connected with two linear springs of stiffnesses k_1 and k_2 , carries out a translational motion of its center of mass S in the vertical direction and a rotation in the plane about S (see Fig. 7.18). The supports A and B can freely move in the horizontal direction to keep the springs in the vertical position. Derive the equations of motion for finite x and φ . Obtain a first integral and use it to derive a modal equation.

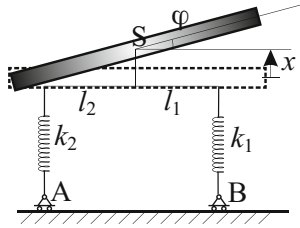

Fig. 7.18 Nonlinear model of vehicle

Solution. Let $q = (x, \varphi)$ denote the generalized coordinates. We write down the kinetic and potential energies of this system as follows

$$\begin{aligned}
 K(\dot{q}) &= \frac{1}{2}m\dot{x}^2 + \frac{1}{2}J_S\dot{\varphi}^2, \\
 U(q) &= \frac{1}{2}k_1(x_{st} + x + l_1 \sin \varphi)^2 + \frac{1}{2}k_2(x_{st} + x - l_2 \sin \varphi)^2 + mgx \\
 &= \frac{1}{2}k_1(x + l_1 \sin \varphi)^2 + \frac{1}{2}k_2(x - l_2 \sin \varphi)^2 \\
 &\quad + ((k_1 + k_2)x_{st} + mg)x + (k_1l_1 - k_2l_2) \sin \varphi + \frac{1}{2}(k_1 + k_2)x_{st}^2.
 \end{aligned}$$

Taking the force and moment equilibrium

$$(k_1 + k_2)x_{st} + mg = 0, \quad (k_1l_1 - k_2l_2)x_{st} = 0$$

into account and removing the last constant term in the potential energy, we can represent it in the form

$$U(x, \varphi) = \frac{1}{2}k_1(x + l_1 \sin \varphi)^2 + \frac{1}{2}k_2(x - l_2 \sin \varphi)^2.$$

It is now straightforward to derive Lagrange's equations

$$\begin{aligned}
 m\ddot{x} + (k_1 + k_2)x + (k_1l_1 - k_2l_2) \sin \varphi &= 0, \\
 J_S\ddot{\varphi} + (k_1l_1 - k_2l_2)x \cos \varphi + \frac{1}{2}(k_1l_1^2 + k_2l_2^2) \sin 2\varphi &= 0.
 \end{aligned}$$

The first integral corresponding to the energy conservation follows

$$\frac{1}{2}m\dot{x}^2 + \frac{1}{2}J_S\dot{\varphi}^2 + U(x, \varphi) = E_0.$$

On the other hand, we can represent the equations of motion in the short form

$$m\ddot{x} = -\frac{\partial U}{\partial x}, \quad J_S\ddot{\varphi} = -\frac{\partial U}{\partial \varphi}.$$

To derive the modal equation, we assume φ as a function of x , without direct reference to time t , and try to eliminate t in these equations. That is, we assume $\varphi = \varphi(x)$ and compute its time derivatives according to the chain rule

$$\dot{\varphi} = \varphi'(x)\dot{x}, \quad \ddot{\varphi} = \varphi''(x)\dot{x}^2 + \varphi'(x)\ddot{x},$$

with prime denoting the derivative of φ with respect to x . Using the first equation of motion to compute the acceleration \ddot{x} and substituting it into the second equation, we get

$$J_S[\varphi''(x)\dot{x}^2 - \frac{1}{m}\varphi'(x)\frac{\partial U}{\partial x}] = -\frac{\partial U}{\partial \varphi}.$$

Next, we substitute $\dot{\varphi}$ into the energy conservation and solve the latter with respect to \dot{x} to find

$$\dot{x}^2 = \frac{2[E_0 - U(x, \varphi)]}{m + J_S\varphi'(x)^2}.$$

The modal equation can finally be obtained by substituting this expression into the above equation

$$J_S \left\{ \varphi''(x) \frac{2[E_0 - U(x, \varphi)]}{m + J_S\varphi'(x)^2} - \frac{1}{m}\varphi'(x)\frac{\partial U}{\partial x} \right\} = -\frac{\partial U}{\partial \varphi}.$$

This last equation can be transformed to

$$2[E_0 - U(x, \varphi)]\varphi''(x) + [m + J_S\varphi'(x)^2]\left[\frac{1}{J_S}\frac{\partial U}{\partial \varphi} - \frac{1}{m}\varphi'(x)\frac{\partial U}{\partial x}\right] = 0,$$

where

$$\begin{aligned} \frac{\partial U}{\partial x} &= (k_1 + k_2)x + (k_1l_1 - k_2l_2)\sin \varphi, \\ \frac{\partial U}{\partial \varphi} &= (k_1l_1 - k_2l_2)x \cos \varphi + \frac{1}{2}(k_1l_1^2 + k_2l_2^2)\sin 2\varphi. \end{aligned}$$

EXERCISE 7.7. Derive equations (7.14).

Solution. We shall derive this system of equations from the equations of slow flow for A_1, B_1, A_2, B_2 obtained in Section 7.2 by the variational asymptotic method

$$\begin{aligned}
 A_{1,\eta} &= \frac{3}{8}B_1(A_1^2 + B_1^2) + \frac{3}{8}B_1(A_2^2 + B_2^2) + \frac{3}{4}B_2(A_1A_2 + B_1B_2), \\
 B_{1,\eta} &= -\frac{3}{8}A_1(A_1^2 + B_1^2) - \frac{3}{8}A_1(A_2^2 + B_2^2) - \frac{3}{4}A_2(A_1A_2 + B_1B_2), \\
 A_{2,\eta} &= \left(\frac{3}{8} + 3\kappa\right)B_2(A_2^2 + B_2^2) + \frac{3}{8}B_2(A_1^2 + B_1^2) + \frac{3}{4}B_1(A_1A_2 + B_1B_2), \\
 B_{2,\eta} &= -\left(\frac{3}{8} + 3\kappa\right)A_2(A_2^2 + B_2^2) - \frac{3}{8}A_2(A_1^2 + B_1^2) - \frac{3}{4}A_1(A_1A_2 + B_1B_2).
 \end{aligned}$$

Multiplying the first equation by A_1 , the second by B_1 , and adding them together, we obtain

$$A_1A_{1,\eta} + B_1B_{1,\eta} = \frac{3}{4}(A_1A_2 + B_1B_2)(A_1B_2 - A_2B_1).$$

Using the definitions of the amplitudes and the phase difference, it is easy to see that the following identities

$$\begin{aligned}
 A_1A_{1,\eta} + B_1B_{1,\eta} &= \frac{1}{2} \frac{d}{d\eta} (A_1^2 + B_1^2) = \frac{1}{2} \frac{d}{d\eta} a_1^2, \\
 A_1A_2 + B_1B_2 &= a_1a_2 \cos(\phi_2 - \phi_1) = a_1a_2 \cos \varphi, \\
 A_1B_2 - A_2B_1 &= a_1a_2 \sin(\phi_2 - \phi_1) = a_1a_2 \sin \varphi
 \end{aligned}$$

hold true transforming the above equation to

$$a_1a_{1,\eta} = \frac{3}{8}a_1^2a_2^2 \sin 2\varphi \quad \Rightarrow \quad a_{1,\eta} = \frac{3}{8}a_1a_2^2 \sin 2\varphi.$$

Thus, the first equation has been proved. The second equation for a_2 can be derived similarly. In this case we multiply the third and the fourth equations of the above system by A_2 and B_2 , respectively, and then add them together. The result is

$$\frac{1}{2} \frac{d}{d\eta} (A_2^2 + B_2^2) = \frac{3}{4}(A_2B_1 - A_1B_2)(A_1A_2 + B_1B_2).$$

With supplement of the following identity

$$A_2B_1 - A_1B_2 = -a_1a_2 \sin \varphi,$$

we transform this equation to

$$a_2a_{2,\eta} = -\frac{3}{8}a_1^2a_2^2 \sin 2\varphi \quad \Rightarrow \quad a_{2,\eta} = -\frac{3}{8}a_1^2a_2 \sin 2\varphi.$$

To derive the equation for the phase difference, we multiply the first equation by A_2 , the second by B_2 , the third by A_1 , and the last by B_1 , and then add them together. The latter, after some calculation, can be written as

$$\frac{d}{d\eta}(A_1A_2 + B_1B_2) = 3\kappa(A_1B_2 - A_2B_1)(A_2^2 + B_2^2).$$

The derivative on the left-hand side of this equation can be expressed in terms of a_1 , a_2 and φ according to

$$\begin{aligned} \frac{d}{d\eta}(a_1a_2 \cos \varphi) &= (a_{1,\eta}a_2 + a_1a_{2,\eta}) \cos \varphi - a_1a_2\varphi_{,\eta} \sin \varphi \\ &= \left(\frac{3}{8}a_1a_2^3 \sin 2\varphi - \frac{3}{8}a_1^3a_2 \sin 2\varphi\right) \cos \varphi - a_1a_2\varphi_{,\eta} \sin \varphi \\ &= \left[\frac{3}{4}a_1a_2(a_2^2 - a_1^2) \cos^2 \varphi - a_1a_2\varphi_{,\eta}\right] \sin \varphi, \end{aligned}$$

whereas the right-hand side is simply $3\kappa a_1a_2^3 \sin \varphi$. Plugging these into the above equation and dividing both sides by $a_1a_2 \sin \varphi$, we obtain the evolution equation for the phase difference

$$\varphi_{,\eta} = \frac{3}{4}(a_2^2 - a_1^2) \cos^2 \varphi - 3\kappa a_2^2,$$

which, by recalling $\cos^2 \varphi = (1 + \cos 2\varphi)/2$, can be rewritten as

$$\varphi_{,\eta} = -\frac{3}{8}(a_1^2 + a_2^2) + 3\left(\frac{1}{4} - \kappa\right)a_2^2 + \frac{3}{8}(a_2^2 - a_1^2) \cos 2\varphi.$$

EXERCISE 7.8. Compute the approximate Poincaré map from the first integral (7.17) numerically for the energy level $E_0 = 0.4$ and for the parameter $\varepsilon = 0.1$, $\kappa = 0.1$, and compare it with the Poincaré map obtained by the numerical integration of the exact equations (7.1).

Solution. In order to compute the Poincaré map of the exact equations (7.1) we adapt the *Mathematica* code written by Weisstein to them. Such modified code is shown below. There are two main functions: the first is used to produce surface of section by condition $x = 0$ with the given initial conditions $x(0) = x_0$, $y(0) = y_0$ and $\dot{y}(0) = \dot{y}_0$, whereas the second plots the result using the ListPlot command. The initial velocity $\dot{x}(0)$ should be computed through others by using the first integral

$$\frac{1}{2}\dot{x}^2 + \frac{1}{2}\dot{y}^2 + \frac{1}{2}(x^2 + y^2) + \frac{\alpha}{4}(x^4 + y^4) + \frac{\beta}{4}(y - x)^4 = E_0,$$

which implies

$$\dot{x}_0 = \sqrt{2E_0 - \dot{y}_0^2 - (x_0^2 + y_0^2) - \frac{\alpha}{2}(x_0^4 + y_0^4) - \frac{\beta}{2}(y_0 - x_0)^4}.$$

```

SurfaceOfSection[{x0_, {y0_, dy0_}, e_, α_, β_}, tmax_] :=
Module[{dx0 = Sqrt[2 e - x0^2 - y0^2 - (α/2 x0^4 - (α/2 y0^4 - (β/2 (y0 - x0)^4 - dy0^2)], x, y, t},
  If[# == {}, {}, First[#]] &@Last[Reap[NDSolve[{
    x''[t] == -x[t] - α x[t]^3 + β (y[t] - x[t])^3,
    y''[t] == -y[t] - α y[t]^3 - β (y[t] - x[t])^3,
    y[0] == y0, y'[0] == dy0, x[0] == x0, x'[0] == dx0},
    {x, y}, {t, 0, tmax}], Method -> {EventLocator, "Event" -> x[t],
    "EventCondition" -> (x'[t] > 0.), "EventAction" -> Sow[{y[t], y'[t]}]}]
  ]
Internal`DeactivateMessages[ListPlot[
  SurfaceOfSection[0., {0., -0.65}, 0.4, 0.1, 0.01], 2000],
  PlotStyle -> {PointSize[.005], Black},
  AspectRatio -> Automatic, AxesLabel -> TraditionalForm /@ {y[t], y'[t]},
  ImageSize -> 500]]

```

The map obtained from the first integral (7.17) can be plotted with the ParametricPlot command. The comparison of these two maps was shown in Fig. 7.11.

EXERCISE 7.9. Prove the formulas (7.29)_{2,3}.

Solution. Let us recall the definitions of matrices A , B , and C

$$A = U^T L_{,v} U, \quad B = U^T L_{,v\varphi} - L_{,v\varphi}^T U, \quad C = U^T E_{,\varphi},$$

where the following abbreviations are used

$$L_{,v\varphi} = \frac{\partial}{\partial \varphi} L_{,v}(u(\varphi), \nabla u(\varphi)), \quad E_{,\varphi} = \frac{\partial}{\partial \varphi} E(L, u), \quad U = \frac{\partial u}{\partial \varphi}.$$

Consider first the matrix B with the elements

$$B_{ij} = U_{im}^T [L_{,v\varphi}]_{mj} - [L_{,v\varphi}^T]_{im} U_{mj},$$

where the elements of matrices U and $L_{,v\varphi}$ are given by

$$U_{im} = \frac{\partial u_i}{\partial \varphi_m}, \quad [L_{,v\varphi}]_{mj} = \frac{\partial}{\partial \varphi_j} \frac{\partial L}{\partial v_m}.$$

Using these formulas for U and $L_{,v\varphi}$, we compute B_{ij} explicitly

$$\begin{aligned}
B_{ij} &= \frac{\partial u_m}{\partial \varphi_i} \frac{\partial}{\partial \varphi_j} \frac{\partial L}{\partial v_m} - \frac{\partial}{\partial \varphi_i} \frac{\partial L}{\partial v_m} \frac{\partial u_m}{\partial \varphi_j} \\
&= \frac{\partial}{\partial \varphi_i} \left(u_m \frac{\partial}{\partial \varphi_j} \frac{\partial L}{\partial v_m} \right) - u_m \frac{\partial^2}{\partial \varphi_i \partial \varphi_j} \frac{\partial L}{\partial v_m} \\
&\quad - \frac{\partial}{\partial \varphi_j} \left(u_m \frac{\partial}{\partial \varphi_i} \frac{\partial L}{\partial v_m} \right) + u_m \frac{\partial^2}{\partial \varphi_j \partial \varphi_i} \frac{\partial L}{\partial v_m} \\
&= \frac{\partial}{\partial \varphi_i} \left(u_m \frac{\partial}{\partial \varphi_j} \frac{\partial L}{\partial v_m} \right) - \frac{\partial}{\partial \varphi_j} \left(u_m \frac{\partial}{\partial \varphi_i} \frac{\partial L}{\partial v_m} \right),
\end{aligned}$$

where the identity of mixed derivatives

$$\frac{\partial^2}{\partial \varphi_i \partial \varphi_j}(\cdot) = \frac{\partial^2}{\partial \varphi_j \partial \varphi_i}(\cdot)$$

has been taken into account. Since u_m and v_m are 2π -periodic in each variable φ_k , so are the expressions in the above parentheses. Thus, it follows immediately that

$$\int_{T^n} B_{ij} = 0.$$

Next, we turn to the vector $Q = U^T E(L, u)$, whose components are

$$\begin{aligned} Q_i &= U_{ik}^T E_k(L, u) = \frac{\partial u_k}{\partial \varphi_i} (\nabla \frac{\partial L}{\partial q_k}(u, \nabla u) - \frac{\partial}{\partial q_k} L(u, \nabla u)) \\ &= \frac{\partial u_k}{\partial \varphi_i} \omega_j \frac{\partial}{\partial \varphi_j} \frac{\partial L}{\partial v_k}(u, \nabla u) - \frac{\partial u_k}{\partial \varphi_i} \frac{\partial L}{\partial u_k}(u, \nabla u) \\ &= \omega_j \frac{\partial}{\partial \varphi_j} \left[\frac{\partial L}{\partial v_k}(u, \nabla u) \frac{\partial u_k}{\partial \varphi_i} \right] - \frac{\partial L}{\partial v_k}(u, \nabla u) \omega_j \frac{\partial^2 u_k}{\partial \varphi_j \partial \varphi_i} - \frac{\partial u_k}{\partial \varphi_i} \frac{\partial L}{\partial u_k}(u, \nabla u). \end{aligned}$$

Noticing that

$$\omega_j \frac{\partial^2 u_k}{\partial \varphi_j \partial \varphi_i} = \frac{\partial}{\partial \varphi_i} \frac{\partial u_k}{\partial \varphi_j} \frac{d\varphi_j}{dt} = \frac{\partial v_k}{\partial \varphi_i},$$

the expression for Q_i reduces to

$$Q_i = \omega_j \frac{\partial}{\partial \varphi_j} \left[\frac{\partial L}{\partial v_k}(u, \nabla u) \frac{\partial u_k}{\partial \varphi_i} \right] - \frac{\partial L}{\partial \varphi_i}.$$

Using the periodicity condition of u and v with respect to φ , we see that the integral of Q_i on the torus also vanishes

$$\int_{T^n} U_{ik}^T E_k(L, u) = 0.$$

EXERCISE 7.10. Simulate numerically the solutions of equations (7.30) satisfying the initial conditions $x(0) = 1, \dot{x}(0) = 0$ and $y(0) = 1, \dot{y}(0) = 0$ for $\varepsilon = 0.1, \alpha = 1$, and $\kappa = 1.2$. Plot the curves $x(t), y(t)$, and $x(t)y(t)$ and compare them with the corresponding curves obtained from the slow flow system (7.33). Explain why synchronization leads to the stationary behavior of the amplitude modulation of $x(t)y(t)$.

Solution. In order to compare the numerical solutions $x(t), y(t)$ of the exact equations (7.30) and their amplitude modulations obeying the slow flow equations (7.33), we need to refer (7.33) to the same time variable. Thus, it is necessary to solve the slow flow equations in $\tau = \omega t$ by changing from η to τ according to

$$\frac{d}{d\eta}(\cdot) = \frac{d}{d\tau}(\cdot) \frac{d\tau}{d\eta} = \frac{1}{\varepsilon} \frac{d}{d\tau}(\cdot).$$

The following pieces of code in *Mathematica* provide the numerical solutions to the systems (7.30) and (7.33). The curves $x(t)$ and $y(t)$ corresponding to the numerical solution of (7.30) as well as their amplitude modulations are shown in Fig. 7.19.

```
sol = NDSolve[{x''[t] + x[t] + ε κ (x[t] - y[t]) - ε (1 - x[t]^2) x'[t] == 0,
  y''[t] + (1 + ε α) y[t] - ε κ (x[t] - y[t]) - ε (1 - y[t]^2) y'[t] == 0,
  x[0] == 1, x'[0] == 0, y[0] == 1, y'[0] == 0}, {x[t], y[t]}, {t, 0, 5 × 10^2}];

slow = NDSolve[{2/e a1'[t] == a1[t] (1 - a1[t]^2/4) + κ a2[t] Sin[φ[t]],
  2/e a2'[t] == a2[t] (1 - a2[t]^2/4) - κ a1[t] Sin[φ[t]],
  2/e φ'[t] == α + κ Cos[φ[t]] (a2[t]/a1[t] - a1[t]/a2[t]), a1[0] == 1, a2[0] == 1, φ[0] == 0},
  {a1[t], a2[t], φ[t]}, {t, 0, 500}];
```

Based on the variational-asymptotic analysis we can present the asymptotic solution (in the first approximation) to the equations of coupled oscillators in the form

$$x_0(t, \eta) = a_1(\eta) \cos(\omega t - \phi_1(\eta)), \quad y_0(t, \eta) = a_2(\eta) \cos(\omega t - \phi_2(\eta)),$$

where $\eta = \varepsilon \tau = \varepsilon \omega t$. Using the product rule of trigonometric functions, we compute their product

$$z_0(t, \eta) = x_0(t, \eta) y_0(t, \eta) = \frac{1}{2} a_1(\eta) a_2(\eta) [\cos(2\omega t - \phi_1(\eta) - \phi_2(\eta)) + \cos \varphi(\eta)].$$

In the expression in square brackets the first summand containing the fast variable t describes the fast oscillating contribution to the product with the amplitude $\frac{1}{2} a_1 a_2$, while the second summand describes the slow oscillating contribution with the same amplitude. Thus, the amplitude modulation of $x(t)y(t)$ at large time can be described asymptotically as

$$a(\eta) = \frac{1}{2} a_1(\eta) a_2(\eta) (1 + \cos \varphi(\eta)).$$

We see that if strong synchronization occurs, then $a(\eta)$ must approach a constant value. The curve $x(t)y(t)$ corresponding to the numerical solution of (7.30) as well as its amplitude modulation, shown in Fig. 7.20, indicates the occurrence of strong synchronization and confirms the analysis provided in Section 7.4.

EXERCISE 7.11. Recheck the slow flow equations (7.33).

Solution. We recall the equations of slow flow for $A_j(\eta)$ and $B_j(\eta)$ obtained in Section 7.4

$$2A_{1,\eta} = -2k_1 B_1 + A_1 - \frac{A_1}{4} (A_1^2 + B_1^2) + \kappa (B_1 - B_2),$$

$$2B_{1,\eta} = 2k_1 A_1 + B_1 - \frac{B_1}{4} (A_1^2 + B_1^2) + \kappa (A_2 - A_1),$$

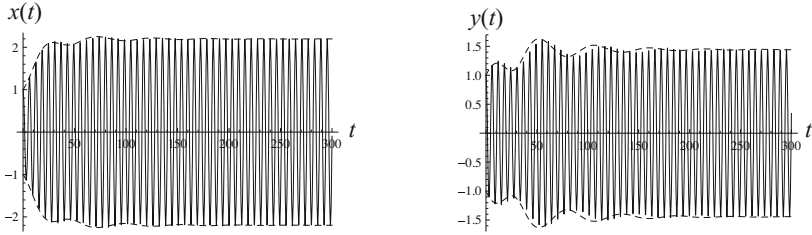

Fig. 7.19 Curves $x(t)$ and $y(t)$ corresponding to the numerical solution of (7.30) (bold lines) and their amplitude modulations in accordance with (7.33) (dashed lines)

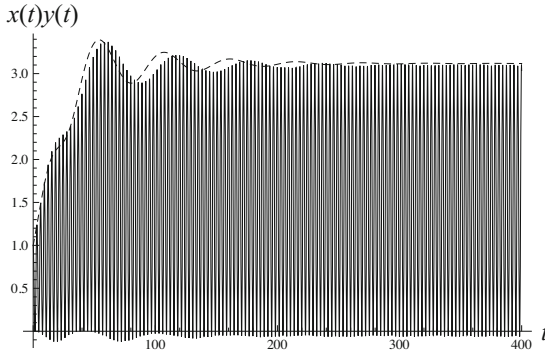

Fig. 7.20 Numerical simulation of the product $x(t)y(t)$ (bold line) and its amplitude modulation (dashed line)

$$2A_{2,\eta} = -2k_1B_2 + \alpha B_2 + A_2 - \frac{A_2}{4}(A_2^2 + B_2^2) + \kappa(B_2 - B_1),$$

$$2B_{2,\eta} = 2k_1A_2 - \alpha A_2 + B_2 - \frac{B_2}{4}(A_2^2 + B_2^2) + \kappa(A_1 - A_2).$$

Multiplying the first equation by A_1 , the second by B_1 , and adding them, then performing the similar operations for the third and the fourth equations, we obtain

$$2(A_1A_{1,\eta} + B_1B_{1,\eta}) = A_1^2 + B_1^2 - \frac{1}{4}(A_1^2 + B_1^2)^2 + \kappa(A_2B_1 - A_1B_2),$$

$$2(A_2A_{2,\eta} + B_2B_{2,\eta}) = A_2^2 + B_2^2 - \frac{1}{4}(A_2^2 + B_2^2)^2 - \kappa(A_2B_1 - A_1B_2).$$

Expressing A_j and B_j in terms of a_1, a_2 and ϕ_1, ϕ_2 , this system can be rewritten as

$$2a_1a_{1,\eta} = a_1^2 - \frac{a_1^4}{4} + \kappa a_1a_2 \sin(\phi_1 - \phi_2),$$

$$2a_2a_{2,\eta} = a_2^2 - \frac{a_2^4}{4} - \kappa a_1a_2 \sin(\phi_1 - \phi_2),$$

which is equivalent to

$$2a_{1,\eta} = a_1 \left(1 - \frac{a_1^2}{4}\right) + \kappa a_2 \sin \varphi,$$

$$2a_{2,\eta} = a_2 \left(1 - \frac{a_2^2}{4}\right) - \kappa a_1 \sin \varphi,$$

where $\varphi = \phi_1 - \phi_2$ is the phase difference.

Returning to the system of slow flow equations, we rewrite them in terms of a_1 , a_2 , ϕ_1 , ϕ_2 as follows

$$\begin{aligned} 2(a_{1,\eta} \cos \phi_1 - a_1 \sin \phi_1 \phi_{1,\eta}) &= -2k_1 a_1 \sin \phi_1 + a_1 \cos \phi_1 \\ &\quad - \frac{1}{4} a_1^3 \cos \phi_1 + \kappa (a_1 \sin \phi_1 - a_2 \sin \phi_2), \\ 2(a_{1,\eta} \sin \phi_1 + a_1 \cos \phi_1 \phi_{1,\eta}) &= 2k_1 a_1 \cos \phi_1 + a_1 \sin \phi_1 \\ &\quad - \frac{1}{4} a_1^3 \sin \phi_1 + \kappa (a_2 \cos \phi_2 - a_1 \cos \phi_1), \\ 2(a_{2,\eta} \cos \phi_2 - a_2 \sin \phi_2 \phi_{2,\eta}) &= -2k_1 a_2 \sin \phi_2 + \alpha a_2 \sin \phi_2 + a_2 \cos \phi_2 \\ &\quad - \frac{1}{4} a_2^3 \cos \phi_2 + \kappa (a_2 \sin \phi_2 - a_1 \sin \phi_1), \\ 2(a_{2,\eta} \sin \phi_2 + a_2 \cos \phi_2 \phi_{2,\eta}) &= 2k_1 a_2 \cos \phi_2 - \alpha a_2 \cos \phi_2 + a_2 \sin \phi_2 \\ &\quad - \frac{1}{4} a_2^3 \sin \phi_2 + \kappa (a_1 \cos \phi_1 - a_2 \cos \phi_2). \end{aligned}$$

Multiplying the first equation by $\sin \phi_1$, the second by $\cos \phi_1$, subtracting the first equation from the second one, and using the identity $\sin^2 \phi + \cos^2 \phi = 1$, we obtain

$$2\phi_{1,\eta} = 2k_1 - \kappa + \kappa \frac{a_2}{a_1} \cos(\phi_1 - \phi_2).$$

In a similar manner, we multiply the third equation by $\sin \phi_2$, the fourth by $\cos \phi_2$ and subtract one from another to get

$$2\phi_{2,\eta} = 2k_1 - \alpha - \kappa + \kappa \frac{a_1}{a_2} \cos(\phi_1 - \phi_2).$$

The evolution equation for the phase difference $\varphi = \phi_1 - \phi_2$ is easily derived by subtracting one from another of two equations just obtained yielding

$$2\varphi_{,\eta} = \alpha + \left(\frac{a_2}{a_1} - \frac{a_1}{a_2}\right) \cos \varphi.$$

EXERCISE 7.12. Solve the slow flow system (7.33) numerically for $\alpha = 1$, and $\kappa = 1.2$, with the initial conditions $a_1(0) = 1$, $a_2(0) = 1$, and $\varphi(0) = 1$. Plot the curves $a_1(t)$, $a_2(t)$, and $\varphi(t)$, and observe their behavior as t becomes large.

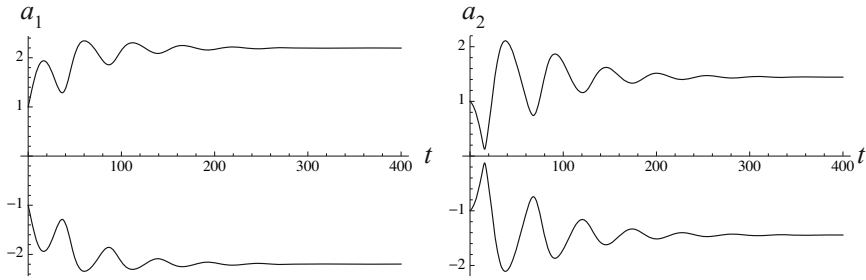

Fig. 7.21 Amplitudes $a_1(t)$ and $a_2(t)$ of the weakly coupled van der Pol's oscillators

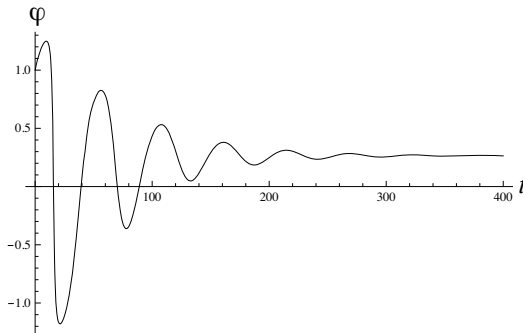

Fig. 7.22 The phase difference $\varphi(t)$ of the weakly coupled van der Pol's oscillators

Solution. The numerical solution of the system can be obtained via the `NDSolve` command provided in *Mathematica*. The plotted curves of amplitudes $a_1(t)$ and $a_2(t)$ are shown adjacent to each other in Fig. 7.21, where it can be seen that they stay constant as time t tends to infinity. The next Figure 7.22 shows the plot of the phase difference $\varphi(t)$. Observe that the phase difference also approaches a constant value as time goes to infinity. The figures illustrated here are generated using the numerical solution obtained with the following piece of code.

```
slow = NDSolve[ {
   $\frac{2}{\epsilon} a_1'[t] == a_1[t] \left( 1 - \frac{a_1[t]^2}{4} \right) + \kappa a_2[t] \text{Sin}[\varphi[t]],$ 
   $\frac{2}{\epsilon} a_2'[t] == a_2[t] \left( 1 - \frac{a_2[t]^2}{4} \right) - \kappa a_1[t] \text{Sin}[\varphi[t]],$ 
   $\frac{2}{\epsilon} \varphi'[t] == \alpha + \kappa \text{Cos}[\varphi[t]] \left( \frac{a_2[t]}{a_1[t]} - \frac{a_1[t]}{a_2[t]} \right), a_1[0] == 1, a_2[0] == 1, \varphi[0] == 0,$ 
  {a1[t], a2[t], phi[t]}, {t, 0, 500} ];
```

The behavior of the amplitudes and of the phase difference indicates that, after a short transient time of unsynchronized oscillations of the amplitudes, the steady-state synchronized vibrations of the coupled oscillators occur. This is also confirmed by the analysis of the coupled self-excited oscillators provided in Section 7.4 and by Fig. 7.14.

Chapter 8

Nonlinear Waves

This Chapter studies several nonlinear equations of wave propagation which admit the exact solutions by the inverse scattering transform. It analyzes also the amplitude and slope modulations obtained by the variational-asymptotic method which may be applied to non-integrable systems as well.

8.1 Solitary and Periodic Waves

Korteweg-de Vries Equation. Let us begin our study of nonlinear waves with the Korteweg-de Vries (KdV) equation [26]

$$u_t + 6uu_x + u_{xxx} = 0. \quad (8.1)$$

This equation arose originally in the theory of shallow water waves, but it is now widely used to describe dispersive waves in various nonlinear media.¹ The constant factor 6 in front of the nonlinear term is conventional but of no great significance. The last term accounts for the dispersion. Due to the balanced effects of nonlinearity and dispersion, waves may propagate without changing their shape. To demonstrate this let us seek a particular solution of (8.1) in form of wave traveling with constant velocity c

$$u = \varphi(\xi), \quad \xi = x - ct,$$

which is similar to d'Alembert's solution for linear hyperbolic waves. Substitution of this Ansatz into (8.1) gives

$$-c\varphi' + 6\varphi\varphi' + \varphi''' = 0,$$

with prime denoting the derivative with respect to ξ . The integration yields

¹ Particularly, Zabusky and Kruskal [54] have shown that the KdV equation is the continuum limit of the equations governing the Fermi-Pasta-Ulam chain. Note that the original KdV equation [53] differs from (8.1) but can be brought to this form by a simple transformation.

$$\varphi'' = -3\varphi^2 + c\varphi - g,$$

where g is an integration constant. This resembles the equation of motion of mass-spring oscillator with a unit mass and a nonlinear restoring force derivable from the cubic potential energy $U(\varphi) = \varphi^3 - \frac{1}{2}c\varphi^2 + g\varphi$.

The first integral of the above equation is

$$\frac{1}{2}\varphi'^2 = -\varphi^3 + \frac{1}{2}c\varphi^2 - g\varphi + h.$$

In the special case when φ and its first derivative tend to zero as $\xi \rightarrow \pm\infty$, we may set $g = h = 0$. Then the first integral becomes

$$\varphi'^2 = \varphi^2(c - 2\varphi).$$

The corresponding phase curve in the (φ, φ') -plane is the separatrix shown in Fig. 8.1 for $c = 1$. It is seen that φ increases from zero at $\xi = -\infty$, rises to a maximum $\varphi_m = c/2$ and then decreases to zero as $\xi \rightarrow \infty$. The solution of the last equation can be found explicitly by quadrature and is given by

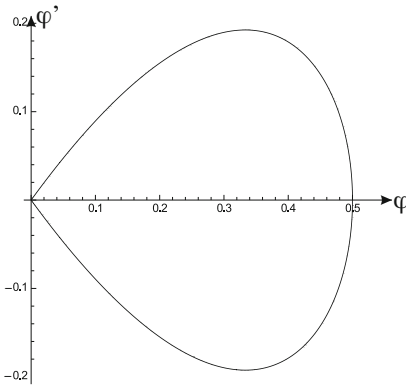

Fig. 8.1 Separatrix

$$\varphi(\xi) = \frac{c}{2} \operatorname{sech}^2\left(\frac{\xi\sqrt{c}}{2}\right).$$

This particular solution is called a soliton. Mention that the solution remains still valid if $\xi = x - ct - d$, where d is any constant. Looking at this solution we can observe that: i) the wave speed of the soliton is twice its amplitude, ii) the width of the soliton is inversely proportional to the square root of the wave speed and therefore taller solitons are narrower in width and move faster than shorter ones. The shape of the solitary wave for $c = 1$ is shown in Fig. 8.2.

In general g and h differ from zero and

$$\varphi'^2 = p(\varphi),$$

where $p(\varphi)$ is a cubic polynomial having three simple zeros. For bounded solutions all zeros must be real, and the periodic solution must oscillate between two of them. Let the zeros be b_1, b_2, b_3 , and we order them such that $b_1 > b_2 > b_3$. Then

$$p(\varphi) = -2(\varphi - b_1)(\varphi - b_2)(\varphi - b_3).$$

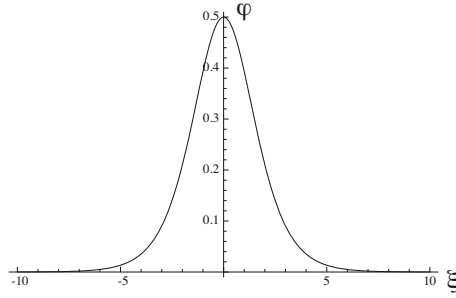

Fig. 8.2 Solitary wave of KdV equation

Since $p(\varphi) > 0$ for $\varphi \in (b_2, b_1)$, the solution oscillates between b_2 and b_1 . So, let us define $a = b_1 - b_2$ as the amplitude of the wave. Comparing $p(\varphi)$ with that in the first integral, we find

$$c = 2(b_1 + b_2 + b_3), \quad g = b_1b_2 + b_1b_3 + b_2b_3, \quad h = b_1b_2b_3.$$

It can easily be checked that the solution of the first integral is expressed in terms of Jacobian elliptic function cn as follows (see exercise 8.1)

$$\varphi(\xi) = b_2 + (b_1 - b_2) \text{cn}^2(\sqrt{(b_1 - b_3)/2}\xi, m), \quad m = \frac{b_1 - b_2}{b_1 - b_3}.$$

Such periodic solutions are called cnoidal waves. As the period of $\text{cn}^2(u, m)$ in its argument u is $2K(m)$, with $K(m)$ being the complete elliptic integral of the first kind, the wave length is

$$\lambda = \frac{2K(m)}{\sqrt{(b_1 - b_3)/2}}. \tag{8.2}$$

The phase velocity of this periodic wave packet is $c = 2(b_1 + b_2 + b_3)$. The solution can also be presented in the form

$$\varphi(\xi) = \psi(\theta) = \psi(kx - \omega t),$$

where $\psi(\theta)$ is the periodic function of period 2π . Since $k = 2\pi/\lambda$, we have for the frequency

$$\omega = ck = 2(b_1 + b_2 + b_3)k.$$

From (8.2), $b_1 - b_3$ is a function of λ and $a = b_1 - b_2$. In the special case $b_2 = 0$ the root b_3 can be expressed through a and the dispersion relation for these periodic waves takes the form

$$\omega = \Omega(k, a).$$

We see that the dispersion relation for nonlinear waves involves the amplitude, what is quite similar to nonlinear vibrations where the frequency depends also on the

amplitude. If the amplitude of the wave is small, $a \ll 1$ and $m \rightarrow 0$ then $2K(m) \simeq \pi$, so $\omega \simeq 2b_3k \simeq -4\frac{\pi^2}{\lambda^2}k = -k^3$, and we recover the dispersion relation of the linearized KdV equation

$$u_t + u_{,xxx} = 0.$$

In contrary, if $b_3 \rightarrow 0$, $m \rightarrow 1$, and $a = b_1 \rightarrow c/2$, then the wavelength λ tends to infinity, and the solution approaches that of soliton.

Nonlinear Klein-Gordon Equation. We turn next to the nonlinear equation which is derivable from the following Lagrangian

$$L = \frac{1}{2}u_t^2 - \frac{1}{2}u_x^2 - U(u).$$

Euler-Lagrange’s equation reads

$$u_{,tt} - u_{,xx} + U'(u) = 0. \tag{8.3}$$

This is the so-called non-linear Klein-Gordon equation which arises in various physical situations. This is especially true of the case $U(u) = 1 - \cos u$ known as the Sine-Gordon equation for which $U'(u) = \sin u$. It describes for instance free torsional vibrations of an elastic rod along which rigid pendulums are attached at close intervals. The pendulums cause additional restoring forces proportional to $\sin u$. Another mechanical problem leading to this equation deals with the motion of dislocations in crystals, where the $\sin u$ term occurs due to the periodic structure of the crystal lattice. Besides, it is used in modeling Josephson junctions, laser pulses and many other phenomena. The alternative choice $U(u) = u^2/2 + \alpha u^4/4$ arises in the problem of free vibrations of a pre-stretched string along which nonlinear springs with the cubic nonlinearity are attached at close intervals. Mention also that the small amplitude expansion of the Sine-Gordon equation leads to this model with $\alpha = -1/6$.

We look first for the soliton traveling with a constant velocity $c < 1$ in the form: $u = \varphi(\xi)$, $\xi = x - ct$. Substitution of this Ansatz into (8.3) gives

$$(1 - c^2)\varphi'' - U'(\varphi) = 0.$$

This resembles the equation of motion of mass-spring oscillator with a mass $m = 1 - c^2$ and a nonlinear restoring force derivable from the potential energy $-U(\varphi)$. The first integral is

$$\frac{1}{2}m\varphi'^2 - U(\varphi) = h.$$

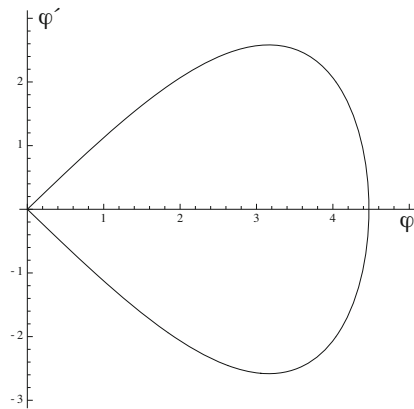

Fig. 8.3 Separatrix

If φ and its first derivative tend to zero as $\xi \rightarrow \pm\infty$, then $h = 0$. For definiteness we consider $U(\varphi) = \varphi^2/2 + \alpha\varphi^4/4$ with a negative α . The first integral with $h = 0$

$$\varphi'^2 = \frac{1}{m} \varphi^2 (1 + \alpha\varphi^2/2)$$

plots as the separatrix in the (φ, φ') -plane shown in Fig. 8.3 for $c = 1/2, \alpha = -0.1$. Thus φ increases from zero at $\xi = -\infty$, rises to a maximum $\varphi_m = \sqrt{2/|\alpha|}$ and then decreases to zero as $\xi \rightarrow \infty$. The solution of the last equation can be found explicitly by quadrature and is given by

$$\varphi(\xi) = \sqrt{\frac{2}{|\alpha|}} \frac{2e^{-|\xi|/\sqrt{1-c^2}}}{1 + e^{-2|\xi|/\sqrt{1-c^2}}}$$

This solitary wave is shown in Fig. 8.4. Mention that the solution remains still valid if $\xi = x - ct - d$, where d is any constant. We can observe that: i) the amplitude of the soliton is constant and independent of the wave speed, ii) the width of the soliton is proportional to $\sqrt{1 - c^2}$, so the narrower soliton moves faster than the wider one.

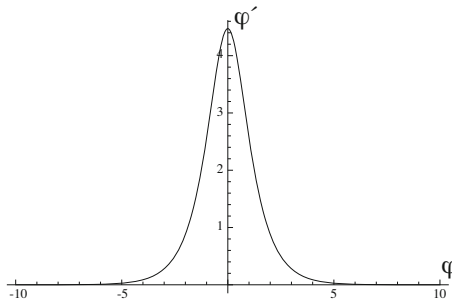

Fig. 8.4 Solitary wave of Klein-Gordon equation

Let us find now the periodic solutions of Klein-Gordon equation. They are obtained by taking $u = \psi(\theta)$, with $\theta = kx - \omega t$, where we assume that $\psi(\theta)$ is 2π -periodic function. Substituting $u = \psi(\theta)$ into (8.3), we get

$$(\omega^2 - k^2)\psi'' + U'(\psi) = 0.$$

The finding of $\psi(\theta)$ is equivalent to searching for the 2π -periodic extremal of the following functional

$$I[\psi] = \int_{\theta_0}^{\theta_0+2\pi} \left[\frac{1}{2}(\omega^2 - k^2)\psi'^2 - U(\psi) \right] d\theta, \tag{8.4}$$

where θ_0 may be set equal to zero without limiting the generality. The first integral of Lagrange's equation reads

$$\frac{1}{2}(\omega^2 - k^2)\psi'^2 + U(\psi) = h.$$

Its solution can be found by the separation of variables. The result is

$$\theta = \frac{\sqrt{\omega^2 - k^2}}{\sqrt{2}} \int \frac{d\psi}{\sqrt{h - U(\psi)}}.$$

If $U(\psi)$ is either a cubic, a quartic, or a trigonometric function, then $\psi(\theta)$ can be expressed in terms of standard elliptic functions. Periodic solutions are obtained when ψ oscillates between two simple zeros of $h - U(\psi)$. At the zeros $\psi'(\theta) = 0$, and the solution has a maximum (crest) or a minimum (trough); these points occur at finite values of θ since the above integral converges when the zeros are simple. We denote the zeros by ψ_1 and ψ_2 and consider the case

$$\psi_1 \leq \psi \leq \psi_2, \quad h - U(\psi) \geq 0, \quad \omega^2 - k^2 > 0.$$

As the period of $\psi(\theta)$ is assumed to be 2π ,

$$2\pi = \frac{\sqrt{\omega^2 - k^2}}{\sqrt{2}} \oint \frac{d\psi}{\sqrt{h - U(\psi)}}. \quad (8.5)$$

The contour integral in this formula denotes the integral over a complete oscillation of ψ from ψ_1 up to ψ_2 and back, so it is equal to twice the integral from ψ_1 to ψ_2 because the sign of the square root has to be changed appropriately in the two parts of the contour. This integral may also be interpreted as the contour integral around a cut from ψ_1 to ψ_2 in the complex ψ -plane.

In the linear case $U(\psi) = \frac{1}{2}\psi^2$, and, as we know, the 2π -periodic solution is

$$\psi(\theta) = a \cos \theta, \quad h = \frac{a^2}{2},$$

so the amplitude a cancels out in the integral on the right-hand side of (8.5). Then (8.5) becomes the linear dispersion relation

$$\omega^2 - k^2 = 1,$$

obtained previously for the linear Klein-Gordon equation. This dispersion relation is also the solvability condition of the variational problem (8.4). In the nonlinear case the parameter h does not drop out of (8.5) and we have the typical dependence of the dispersion relation on the amplitude. Consider for example the case $U(\varphi) = \varphi^2/2 + \alpha\varphi^4/4$ with small α . Then (8.4) is exactly the variational problem (5.4) studied by the variational-asymptotic (or Lindstedt-Poincaré) method in Section 5.1, with ω^2 replaced by $\omega^2 - k^2$ and ε by α . Therefore the following asymptotic formulas

$$\sqrt{\omega^2 - k^2} = 1 + \frac{3}{8}\alpha a^2 \quad \Rightarrow \quad \omega^2 - k^2 = 1 + \frac{3}{4}\alpha a^2,$$

and

$$\psi(\theta) = a \cos \theta + \alpha \frac{a^3}{32} (\cos 3\theta - \cos \theta)$$

follow at once.

Behavior of Solitons. Through extensive numerical simulations of the KdV equation² the following remarkable behavior of solitons was discovered. If we consider two solitons traveling from left to right with the taller one behind as shown in Fig. 8.5, then since the taller soliton moves faster than the shorter soliton, they will collide. After a short collision time of nonlinear interaction and overlapping the solitons separate again, with the taller one now ahead, and the amplitudes and velocities regain their initial values. The only effect of nonlinear interaction are phase shifts, that is the centers of solitons are slightly shifted from the places where they should have been as if there had been no interaction (see Fig. 8.6). This resembles the collision of particles; so similar to particles the name soliton was given to these special waves.

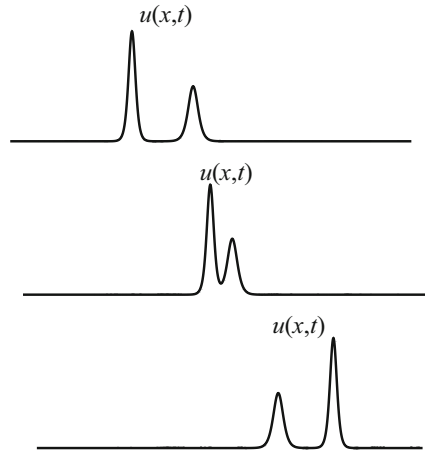

Fig. 8.5 2 traveling solitons

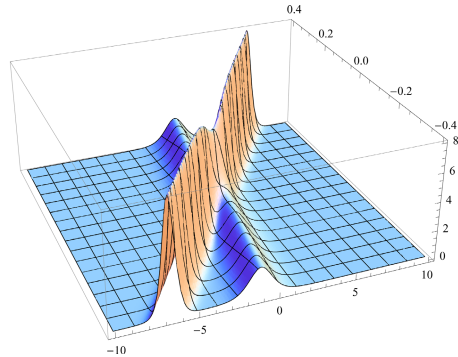

Fig. 8.6 Two-soliton solution of the KdV equation

This remarkable numerical discovery led to a series of first integrals of the KdV equation. All these first integrals are of the form

² First initiated by Zabusky and Kruskal in 1965 [54].

$$I_j = \int_{-\infty}^{\infty} P_j(u, u_x, \dots, \frac{\partial^j u}{\partial x^j}) dx = \text{const},$$

where P_j are polynomials. For example, the first three integrals are (see exercise 8.3)

$$I_{-1} = \int_{-\infty}^{\infty} u dx, \quad I_0 = \int_{-\infty}^{\infty} u^2 dx, \quad I_1 = \int_{-\infty}^{\infty} (u^3 - \frac{1}{2}u_x^2) dx.$$

In searching for further first integrals of the KdV equation Miura discovered the following transformation: if v is a solution of the modified KdV equation

$$v_{,t} - 6v^2v_{,x} + v_{,xxx} = 0,$$

then

$$u = -(v^2 + v_{,x})$$

satisfies KdV equation. This is readily seen from the relation

$$u_{,t} + 6uu_{,x} + u_{,xxx} = -(2v + \partial_x)(v_{,t} - 6v^2v_{,x} + v_{,xxx}).$$

The equation $u = -(v^2 + v_{,x})$ may be viewed as Riccati's equation for v in terms of u . It can be transformed to a linear equation by substituting $v = \psi_{,x}/\psi$. This yields

$$\psi_{,xx} + u\psi = 0.$$

Since the KdV equation is Galilean invariant, that is invariant under the transformation

$$(x, t, u(x, t)) \rightarrow (x - ct, t, u(x, t) + \frac{1}{6}c),$$

it is natural to replace u by $u - \lambda$ and consider the equation

$$\psi_{,xx} + u\psi = \lambda\psi.$$

This is nothing else but the stationary Schrödinger equation which has been studied extensively in context of the scattering problem, where function $-u(x, t)$ plays the role of the scattering potential. The association of the Schrödinger equation with the KdV equation led Gardner, Green, Kruskal, and Miura later [16] to the fruitful development of a beautiful mathematical method called inverse scattering transform which can be used to fully integrate a wide class of nonlinear partial differential equations [1]. We consider this method in the next Section.

8.2 Inverse Scattering Transform

This Section presents the analytical solution of KdV equation based on the inverse scattering transform.³

³ See the detailed derivations in [1].

Lax Pair. Let us consider the KdV equation (8.1) subject to the initial condition

$$u(x, 0) = u_0(x),$$

where $u_0(x)$ decays sufficiently rapidly as $|x| \rightarrow \infty$. Since the KdV equation is non-linear, the Fourier transform cannot directly be applied to solve this initial-value problem. However, as motivated in the previous Section, we can relate this equation to the stationary Schrödinger equation

$$L\psi = \lambda \psi, \quad (8.6)$$

where L is the linear operator defined by

$$L\psi = \psi_{,xx} + u(x, t)\psi.$$

The idea is based on the following construction proposed by Lax [30]. Assume that ψ evolves in time in accordance with

$$\psi_{,t} = A\psi. \quad (8.7)$$

Thus, A is the linear operator governing the time evolution of ψ . Now we calculate the time derivative of equation (8.6)

$$L_{,t}\psi + L\psi_{,t} = \lambda_{,t}\psi + \lambda\psi_{,t}.$$

Taking into account (8.7) we transform the above equation to

$$(L_{,t} + LA - AL)\psi = \lambda_{,t}\psi.$$

Thus, if $\lambda_{,t} = 0$, then the so-called Lax equation

$$L_{,t} + [L, A] = 0, \quad [L, A] = LA - AL,$$

holds true. The problem reduces then to finding A so that Lax's equation is compatible with the KdV equation. It is easy to show by the direct inspection (see exercise 8.4) that Lax's equation is compatible with the KdV equation if we choose A as follows

$$A\psi = (\gamma + u_{,x})\psi - (4\lambda + 2u)\psi_{,x}, \quad (8.8)$$

where γ is an arbitrary constant. The byproduct of Lax's construction is that the KdV equation possesses an infinite number of first integrals since all eigenvalues of $L\psi = \lambda\psi$ are such first integrals. The linear operators L and A , called Lax's pair, have been found later on for a wide class of nonlinear partial differential equations, including the Sine-Gordon equation, the nonlinear Schrödinger equation, the Kadomtsev-Petviashvili equation and many other equations of mathematical physics.⁴

⁴ The list of fully integrable nonlinear equations can be found in [1].

Inverse Scattering Transform. Based on the Lax representation we can now solve the KdV equation, corresponding to $u \rightarrow 0$ as $|x| \rightarrow \infty$, in three steps sketched below. The mathematical justification will be given in the next paragraph.

i) First step. At time $t = 0$ the initial condition $u(x, 0) = u_0(x)$ is known. With these given initial data we solve the direct scattering problem: find the eigenvalues and the corresponding eigenfunctions of (8.6). One can show that the spectrum of the Schrödinger equation with $u(x, t) \rightarrow 0$ as $|x| \rightarrow \infty$ is discrete for $\lambda > 0$ and continuous for $\lambda < 0$. Denote the discrete eigenvalues by $\lambda = \kappa_n^2$, $n = 1, 2, \dots, N$ and the continuous eigenvalues by $\lambda = -k^2$. It turns out that the normalized eigenfunctions corresponding to the discrete eigenvalues behave asymptotically as $x \rightarrow \infty$ according to

$$\psi_n(x, t) \sim \sigma_n(t) e^{-\kappa_n x},$$

with the normalization condition

$$\int_{-\infty}^{\infty} \psi_n^2 dx = 1.$$

For the continuous spectrum the asymptotic behaviors of the eigenfunctions are described by

$$\begin{aligned} \psi(x, t) &\sim e^{-ikx} + \rho(k, t) e^{ikx} & \text{as } x \rightarrow \infty, \\ \psi(x, t) &\sim \tau(k, t) e^{-ikx} & \text{as } x \rightarrow -\infty, \end{aligned}$$

where $\rho(k, t)$ is the reflection coefficient and $\tau(k, t)$ the transmission coefficient. At $t = 0$ the obtained scattering data

$$S(\lambda, 0) = (\{\kappa_n, \sigma_n(0)\}_{n=1}^N, \rho(k, 0), \tau(k, 0))$$

serve as the input data for the next step.

ii) Second step. We use now the evolution equation (8.7) with A from (8.8) to determine the time dependence of the scattering data. We know that κ_n are unchanged. It will be shown that, for $n = 1, 2, \dots, N$

$$\sigma_n(t) = \sigma_n(0) e^{4\kappa_n^3 t},$$

and

$$\begin{aligned} \tau(k, t) &= \tau(k, 0), \\ \rho(k, t) &= \rho(k, 0) e^{8ik^3 t}. \end{aligned}$$

Thus, the scattering data at time t are given by

$$S(\lambda, t) = (\{\kappa_n, \sigma_n(t)\}_{n=1}^N, \rho(k, t), \tau(k, t)).$$

We use this as the input data for the last step.

iii) Third (last) step. At this final step we solve the inverse scattering problem: reconstruct the potential $u(x, t)$ which is the solution of the KdV equation from the knowledge of the scattering data $S(\lambda, t)$. The results may be summarized as follows. From the scattering data we find the function

$$F(x, t) = \sum_{n=1}^N \sigma_n^2(t) e^{-\kappa_n x} + \frac{1}{2\pi} \int_{-\infty}^{\infty} \rho(k, t) e^{ikx} dk.$$

We then solve the linear integral equation

$$K(x, y, t) + F(x + y, t) + \int_x^{\infty} K(x, z, t) F(z + y, t) dz = 0, \tag{8.9}$$

called Gelfand-Levitan equation. Finally we compute $u(x, t)$ in accordance with

$$u(x, t) = 2 \frac{\partial}{\partial x} [K(x, x, t)].$$

As we see, this method is conceptually quite similar to the Fourier transform used for solving linear equations (cf. Chapter 4), except that the last step of solving the inverse scattering problem is highly nontrivial. Schematically, the described steps may be summarized in the following diagram

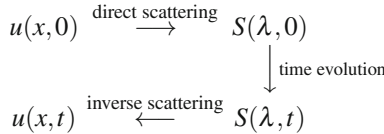

In this diagram the direct scattering plays the role of the Fourier transform, while the inverse scattering the inverse Fourier transform. The time evolution of the scattering data is similar to the multiplication of the Fourier image with function $e^{i\Omega(k)t}$ which accounts for the dispersion. Note that at each step we have to deal just with linear problems which are “doable”.

Mathematical Justification. In this paragraph we present briefly the justification of the above results based on the direct and inverse scattering problems.⁵ In the direct scattering problem it is convenient to put $\lambda = -k^2$ and write (8.6) as

$$\psi_{,xx} + [u(x, t) + k^2] \psi = 0.$$

For a given k we let $\phi(x, k)$, $\bar{\phi}(x, k)$ and $\psi(x, k)$, $\bar{\psi}(x, k)$ be the corresponding eigenfunctions which satisfy the following asymptotic behaviors

$$\begin{array}{l}
 \phi(x, k) \sim e^{ikx}, \quad \bar{\phi}(x, k) \sim e^{-ikx} \quad \text{as } x \rightarrow \infty, \\
 \psi(x, k) \sim e^{-ikx}, \quad \bar{\psi}(x, k) \sim e^{ikx} \quad \text{as } x \rightarrow -\infty.
 \end{array}$$

⁵ See the detailed expositions in [1].

Equation (8.6) is a linear second order differential equation. Therefore, between these eigenfunctions there are linear relationships

$$\begin{aligned}\psi(x, k) &= a(k)\bar{\phi}(x, k) + b(k)\phi(x, k), \\ \bar{\psi}(x, k) &= -\bar{a}(k)\phi(x, k) + \bar{b}(k)\bar{\phi}(x, k).\end{aligned}$$

where $a(k)$ and $b(k)$ satisfy the following symmetry properties

$$\bar{a}(k) = -a(-k) = -a^*(k^*), \quad \bar{b}(k) = b(-k) = b^*(k^*).$$

Besides, the following identity holds true

$$a(k)\bar{a}(k) + b(k)\bar{b}(k) = -1.$$

This can easily be checked by computing the Wronskians giving

$$W(\psi(x, k), \bar{\psi}(x, -k)) = [a(k)\bar{a}(k) + b(k)\bar{b}(k)]W(\phi(x, k), \bar{\phi}(x, k)).$$

We introduce $\tau(k) = 1/a(k)$ and $\rho(k) = b(k)/a(k)$ as the transmission and reflection coefficients, respectively and consider the normalized eigenfunction $\psi(x, k)/a$ as in the previous paragraph. It is easy to see that $|\rho(k)|^2 + |\tau(k)|^2 = 1$.

We turn now to the time dependence of the scattering data. The evolution of $\psi(x, k, t)$ is described by (8.7), with A from (8.8). We introduce the modified eigenfunction $N(x, k, t)$ such that

$$\frac{1}{a}\psi(x, k, t) = N(x, k, t)e^{-ikx}.$$

Then N satisfies the equation

$$N_{,t} = (\gamma - 4ik^3 + u_{,x} + 2iku)N + (4k^2 - 2u)N_{,x}.$$

The asymptotic behavior of $\psi(x, k, t)$ implies that

$$\begin{aligned}N(x, k, t) &\rightarrow \tau(k, t) \quad \text{as } x \rightarrow -\infty, \\ N(x, k, t) &\rightarrow 1 + \rho(k, t)e^{2ik} \quad \text{as } x \rightarrow \infty.\end{aligned}$$

By considering the above equation for $N(x, k, t)$ as $x \rightarrow -\infty$ and using the fact that u and its first derivative tend to zero in this limit, we obtain

$$\tau_{,t} = (\gamma - 4ik^3)\tau.$$

Thus, the choice $\gamma = 4ik^3$ makes the transmission coefficient $\tau(k)$ independent of t . Then, in the other limit $x \rightarrow \infty$ we get

$$\rho_{,t} = 8ik^3\rho \quad \Rightarrow \quad \rho(k, t) = \rho(k, 0)e^{8ik^3t}.$$

Concerning the discrete spectrum we know that the eigenvalues $\lambda = \kappa_n^2$ are positive and time independent. Denote by $\chi_n(x, \kappa_n, t)$ the eigenfunctions with the asymptotic behavior $\chi_n \sim e^{-\kappa_n x}$ as $x \rightarrow \infty$ and assume that $\psi_n(x, t) = \sigma_n(t)\chi_n(x, \kappa_n, t)$. With (8.6) and (8.7) it is easy to check that

$$\frac{d}{dt} \int_{-\infty}^{\infty} \chi_n^2 dx = -8\kappa_n^3 \int_{-\infty}^{\infty} \chi_n^2 dx.$$

Taking into account the normalization condition we have

$$\sigma_n^2(t) = \frac{1}{\int_{-\infty}^{\infty} \chi_n^2 dx}.$$

Thus,

$$\sigma_n^2(t) = \sigma_n^2(0)e^{8\kappa_n^3 t} \Rightarrow \sigma_n(t) = \sigma_n(0)e^{4\kappa_n^3 t}.$$

The rigorous derivation of the Gelfand-Levitan integral equation requires a deeper insight into the spectral analysis [18] than that provided so far. Let us show nevertheless how to obtain, at least formally, this equation by working with the Schrödinger equation in an equivalent “time domain”. We consider equation (8.6) as the Fourier transform of the “wave” equation

$$\varphi_{,xx} - \varphi_{,\theta\theta} + u\varphi = 0, \tag{8.10}$$

where function $\varphi(x, \theta, t)$ is the Fourier image of $\psi(x, k, t)$ with respect to k

$$\varphi(x, \theta, t) = \int_{-\infty}^{\infty} \psi(x, k, t)e^{ik\theta} dk.$$

We suppress at present the true time variable t . Consider an incident wave $\varphi = \delta(x + \theta)$ from $x = \infty$ and let the reflected wave be $F(x - \theta)$. Thus,

$$\varphi \sim \varphi_{\infty} = \delta(x + \theta) + F(x - \theta) \quad \text{as } x \rightarrow \infty.$$

We propose that the corresponding solution of (8.10) may be written

$$\varphi(x, \theta) = \varphi_{\infty}(x, \theta) + \int_x^{\infty} K(x, z)\varphi_{\infty}(x, \theta) dz,$$

what is equivalent to a crucial step in Gelfand-Levitan’s work. By direct substitution in (8.10) we verify that there is such a solution provided

$$\begin{aligned} K_{,zz} - K_{,xx} + uK &= 0, \quad z > x, \\ u(x) &= 2\frac{d}{dx}K(x, x), \\ K, K_{,z} &\rightarrow 0 \quad \text{as } x \rightarrow \infty. \end{aligned}$$

This is a well-posed problem, therefore $K(x, z)$ exists. From the causality property of the wave equation we know that φ must vanish for $x + \theta < 0$. Therefore

$$\varphi_\infty(x, \theta) + \int_x^\infty K(x, z)\varphi_\infty(x, \theta) dz = 0 \quad \text{for } x + \theta < 0.$$

Introducing the expression for $\varphi_\infty(x, \theta)$ in this equation we get

$$K(x, -\theta) + F(x - \theta) + \int_x^\infty K(x, z)F(z - \theta) dz = 0 \quad \text{for } x + \theta < 0.$$

With $\theta = -y$ this becomes Gelfand-Levitan equation (8.9). At a fixed time t , F is determined from the direct scattering problem in terms of $u(x, t)$ as

$$F(x - \theta) = \sum_{n=1}^N \sigma_n^2(t)e^{-\kappa_n(x-\theta)} + \frac{1}{2\pi} \int_{-\infty}^\infty \rho(k, t)e^{ik(x-\theta)} dk.$$

With $\theta = -y$ and with the scattering data at time t we obtain the expression for F in the Gelfand-Levitan equation.

Reflectionless Potential. The solution of the Gelfand-Levitan equation simplifies considerably if the reflection coefficient is zero. In this case we obtain the special soliton solutions by the separation of variables. Indeed, if $\rho(k, t) = 0$, then we have for function $F(x, t)$

$$F(x, t) = \sum_{n=1}^N \sigma_n^2(t)e^{-\kappa_n x},$$

with $\sigma_n(t) = \sigma_n(0)e^{4\kappa_n^3 t} > 0$ and distinct $\kappa_n > 0$, $n = 1, 2, \dots, N$. So the Gelfand-Levitan equation becomes

$$K(x, y, t) + \sum_{n=1}^N \sigma_n^2(t)e^{-\kappa_n(x+y)} + \int_x^\infty K(x, z, t) \sum_{n=1}^N \sigma_n^2(t)e^{-\kappa_n(z+y)} dz = 0.$$

We seek the solution of this equation in the form

$$K(x, y, t) = \sum_{n=1}^N \sigma_n v_n(x)e^{-\kappa_n y}.$$

Substituting this solution Ansatz into the integral equation we get for $m = 1, 2, \dots, N$

$$v_m(x) + \sum_{n=1}^N \frac{\sigma_m(t)\sigma_n(t)}{\kappa_m + \kappa_n} e^{-(\kappa_m + \kappa_n)x} v_n(x) = \sigma_m(t)e^{-\kappa_m x}.$$

This is a system of N algebraic equations which can be written in the matrix form as

$$(\mathbf{I} + \mathbf{C})\mathbf{v} = \mathbf{f}, \tag{8.11}$$

where $\mathbf{v} = (v_1, v_2, \dots, v_N)^T$, $\mathbf{f} = (f_1, f_2, \dots, f_N)^T$ with $f_m = \sigma_m e^{-\kappa_m x}$, $m = 1, 2, \dots, N$, \mathbf{I} is the identity matrix and \mathbf{C} is a symmetric $N \times N$ matrix with elements

$$C_{mn} = \frac{\sigma_m(t)\sigma_n(t)}{\kappa_m + \kappa_n} e^{-(\kappa_m + \kappa_n)x}, \quad m, n = 1, 2, \dots, N.$$

A sufficient condition for the system (8.11) to have a unique solution is that \mathbf{C} is positive definite. The latter holds true because the quadratic form

$$\xi \cdot \mathbf{C} \xi = \sum_{m=1}^N \sum_{n=1}^N \frac{\sigma_m(t)\sigma_n(t)\xi_m\xi_n}{\kappa_m + \kappa_n} e^{-(\kappa_m + \kappa_n)x} = \int_x^\infty \left(\sum_{n=1}^N \sigma_n(t)\xi_n e^{-\kappa_n x} \right)^2 dy$$

is clearly positive for an arbitrary $\xi \neq \mathbf{0}$. The unique solution to the KdV equation in this case is

$$u(x, t) = 2 \frac{\partial^2}{\partial x^2} [\ln \det(\mathbf{I} + \mathbf{C})]. \quad (8.12)$$

Soliton Solutions. Consider first the simplest case $N = 1$ for which

$$C = \frac{\sigma_1^2(t)}{2\kappa_1} e^{-2\kappa_1 x} = \frac{\sigma_1^2(0)}{2\kappa_1} e^{-2\kappa_1 x + 8\kappa_1^3 t}.$$

Introducing $\xi = x - ct - d$, where

$$c = 4\kappa_1^2, \quad d = -\frac{1}{\kappa_1} \ln \frac{\sigma_1(0)}{2\kappa_1},$$

we may write $C = e^{-2\kappa_1 \xi}$. Then

$$u(x, t) = 2 \frac{\partial^2}{\partial x^2} [\ln(1 + C)] = 8\kappa_1^2 \frac{C}{(1 + C)^2} = 2\kappa_1^2 \operatorname{sech}^2(\kappa_1 \xi)$$

coincides with the one soliton solution obtained in Section 8.1.

For $N = 2$ we have

$$\Delta = \det(\mathbf{I} + \mathbf{C}) = 1 + e^{-2\kappa_1 \xi_1} + e^{-2\kappa_2 \xi_2} + e^{-2\kappa_1 \xi_1 - 2\kappa_2 \xi_2 + A_{12}},$$

with

$$\xi_n = x - 4\kappa_n^2 t - d_n, \quad A_{12} = 2 \ln \left(\frac{\kappa_1 - \kappa_2}{\kappa_1 + \kappa_2} \right).$$

This formula implies that the only effect of the interaction of two solitary waves is a phase shift. Indeed, consider the trajectory $\xi_1 = \text{const}$, and assume that $\kappa_1 > \kappa_2 > 0$. Then

$$\begin{aligned} \Delta &\sim 1 + e^{-2\kappa_1 \xi_1} \quad \text{as } t \rightarrow -\infty, \\ \Delta &\sim e^{-2\kappa_2 \xi_2} + e^{-2\kappa_1 \xi_1 - 2\kappa_2 \xi_2 + A_{12}} \quad \text{as } t \rightarrow \infty. \end{aligned}$$

Therefore, from (8.12) it follows that for fixed ξ_1

$$u(x, t) = 2 \frac{\partial^2}{\partial x^2} (\ln \Delta) \sim 2\kappa_1^2 \operatorname{sech}^2(\kappa_1 \xi_1 + \delta_1^\pm) \quad \text{as } t \rightarrow \pm\infty,$$

with

$$\delta_1^+ = \frac{1}{2}A_{12}, \quad \delta_1^- = 0.$$

Similarly, for fixed ξ_2

$$u(x, t) \sim 2\kappa_2^2 \operatorname{sech}^2(\kappa_2 \xi_2 + \delta_2^\pm) \quad \text{as } t \rightarrow \pm\infty,$$

with

$$\delta_2^+ = 0, \quad \delta_2^- = \frac{1}{2}A_{12}.$$

Thus, for large negative time, the taller soliton is behind the shorter one, and vice-versa for large positive time. The phase shifts of solitons are $A_{12}/2$ and $-A_{12}/2$, respectively.

The calculations for N solitons show the similar behavior. If $\kappa_1 > \kappa_2 > \dots > \kappa_N > 0$, then for fixed ξ_n

$$u(x, t) \sim 2\kappa_n^2 \operatorname{sech}^2(\kappa_n \xi_n + \delta_n^\pm) \quad \text{as } t \rightarrow \pm\infty,$$

where

$$\delta_n^+ = \sum_{m=n+1}^N \ln \left(\frac{\kappa_n - \kappa_m}{\kappa_n + \kappa_m} \right), \quad \delta_n^- = \sum_{m=1}^{n-1} \ln \left(\frac{\kappa_m - \kappa_n}{\kappa_m + \kappa_n} \right).$$

Therefore, the n -th soliton undergoes a phase shift given by

$$\delta_n = \delta_n^+ - \delta_n^- = \sum_{m=n+1}^N \ln \left(\frac{\kappa_n - \kappa_m}{\kappa_n + \kappa_m} \right) - \sum_{m=1}^{n-1} \ln \left(\frac{\kappa_m - \kappa_n}{\kappa_m + \kappa_n} \right).$$

We see that the total phase shift is equal to the sum of phase shifts resulted from pair interaction with every other soliton.

To illustrate the relationship between the initial condition and the number of solitons, let us take the initial condition in the form

$$u(x, n) = N(N + 1)\operatorname{sech}^2 x.$$

In this case the scattering problem, with $\lambda = \kappa^2$, reads

$$\psi_{,xx} + [N(N + 1)\operatorname{sech}^2 x - k^2]\psi = 0.$$

If we make the transformation $\mu = \tanh x$, then this equation becomes

$$(1 - \mu^2) \frac{d^2 \psi}{d\mu^2} - 2\mu \frac{d\psi}{d\mu} + [N(N + 1) - \frac{\kappa^2}{1 - \mu^2}]\psi = 0, \tag{8.13}$$

which is the associate Legendre equation (see [3]). Equation (8.13) has N distinct eigenvalues $\kappa_n = 1, 2, \dots, N$ and bounded eigenfunctions in terms of Legendre polynomials

$$\psi_n(x) = \gamma_n P_N^n(\tanh x) \sim c_n e^{-nx} \quad \text{as } x \rightarrow \infty,$$

where c_n is determined from the normalization condition. The N -soliton solution of the KdV equation is given by (8.12), where

$$C_{mn} = \frac{c_m + c_n}{m + n} e^{-(m+n)x}.$$

In particular, the two-soliton solution of the KdV equation satisfying the above initial condition for $N = 2$ reads

$$u(x, t) = 12 \frac{3 + 4 \cosh(2x - 8t) + \cosh(4x - 64t)}{[3 \cosh(x - 28t) + \cosh(3x - 36t)]^2}.$$

If we introduce $\xi_1 = x - 16t$ and $\xi_2 = x - 4t$, then the two-soliton solution can be expressed as

$$u(x, t) = 12 \frac{3 + 4 \cosh(2\xi_1 + 24t) + \cosh(4\xi_1)}{[3 \cosh(\xi_1 - 12t) + \cosh(3\xi_1 + 12t)]^2},$$

and, alternatively,

$$u(x, t) = 12 \frac{3 + 4 \cosh(2\xi_2) + \cosh(4\xi_2 - 48t)}{[3 \cosh(\xi_2 - 24t) + \cosh(3\xi_2 - 24t)]^2}.$$

Expanding these formulas, keeping ξ_1 (alternatively ξ_2) fixed, it is easy to see that as $t \rightarrow \pm\infty$

$$u(x, t) \sim 2 \operatorname{sech}^2\left(\xi_2 \pm \frac{1}{2} \ln 3\right) + 8 \operatorname{sech}^2\left(2\xi_1 \mp \frac{1}{2} \ln 3\right).$$

Thus, the phase shifts are $\pm \ln 3/2$ in this case.

8.3 Energy Method

In this Section we are going to apply the variational-asymptotic method to general variational problems of wave propagation.

Variational-Asymptotic Method. Consider the variational problem in form of Hamilton's variational principle: find the extremal of the action functional

$$I[u_i(\mathbf{x}, t)] = \iint_R L(u_i, u_{i,\alpha}, u_{i,t}) dx dt, \tag{8.14}$$

where $R = V \times (t_0, t_1)$ is any finite and fixed region in $(d + 1)$ -dimensional space-time. We assume that u_i are prescribed at the boundary ∂R . We look for the extremal of this variational problem in form of a slowly varying wave packet⁶

$$u_i = \psi_i(\theta, \mathbf{x}, t), \quad (8.15)$$

where θ is a function of \mathbf{x} and t , ψ_i are 2π -periodic functions with respect to θ . Function θ plays the role of the phase, while $\theta_{,\alpha}$ and $-\theta_{,t}$ correspond to the wave vector k_α and the frequency ω , respectively. As in the linear case we assume that functions $\theta_{,\alpha}$, $\theta_{,t}$ and $\psi_i(\theta, \mathbf{x}, t)|_{\theta=\text{const}}$ change slowly in one wavelength λ and one period τ . The latter are defined as the best constants in the inequalities

$$|\theta_{,\alpha}| \leq \frac{2\pi}{\lambda}, \quad |\theta_{,t}| \leq \frac{2\pi}{\tau}. \quad (8.16)$$

The characteristic length- and time-scales Λ and T of changes of the functions $\theta_{,\alpha}$, $\theta_{,t}$ and $\psi_i(\theta, \mathbf{x}, t)|_{\theta=\text{const}}$ are defined as the best constants in the inequalities

$$\begin{aligned} |\theta_{,\alpha\beta}| \leq \frac{2\pi}{\lambda\Lambda}, \quad |\theta_{,\alpha t}| \leq \frac{2\pi}{\lambda T}, \quad |\theta_{,\alpha t}| \leq \frac{2\pi}{\tau\Lambda}, \quad |\theta_{,tt}| \leq \frac{2\pi}{\tau T}, \\ |\partial_\alpha \psi_i| \leq \frac{\bar{\psi}_i}{\Lambda}, \quad |\partial_t \psi_i| \leq \frac{\bar{\psi}_i}{T}, \quad |\psi_{i,\theta}| \leq \bar{\psi}_i, \end{aligned} \quad (8.17)$$

where $\partial_\alpha \psi_i = \partial \psi_i / \partial x_\alpha$ with $\theta = \text{const}$, and $\partial_t \psi_i = \partial \psi_i / \partial t$ with $\theta = \text{const}$. Therefore it makes sense to call θ “fast” variable as opposed to the “slow” variables x_α and t . Thus, in this variational problem we have two small parameters λ/Λ and τ/T .

We now calculate the derivatives $u_{i,\alpha}$ and $u_{i,t}$. According to (8.15)

$$u_{i,\alpha} = \partial_\alpha \psi_i + \psi_{i,\theta} \theta_{,\alpha}, \quad u_{i,t} = \partial_t \psi_i + \psi_{i,\theta} \theta_{,t}.$$

Because of (8.16) and (8.17) they can be approximately replaced by

$$u_{i,\alpha} = \psi_{i,\theta} \theta_{,\alpha}, \quad u_{i,t} = \psi_{i,\theta} \theta_{,t}.$$

Keeping in the action functional (8.14) the asymptotically principal terms, we obtain in the first approximation

$$I_0[\psi_i] = \iint_R L(\psi_i, \psi_{i,\theta} \theta_{,\alpha}, \psi_{i,\theta} \theta_{,t}) dx dt.$$

Similar to the linear case we decompose the domain R into the $(d + 1)$ -dimensional strips bounded by the d -dimensional phase surfaces $\theta = 2\pi n$, $n = 0, \pm 1, \pm 2, \dots$. The integral over R can then be replaced by the sum of the integrals over the strips

⁶ The amplitudes a_i appear later.

$$\iint_R L dx dt = \sum \iint L(\psi_i, \psi_{i,\theta}, \theta_{,\alpha}, \psi_{i,\theta}, \theta_{,t}) \kappa d\theta d\zeta, \quad (8.18)$$

where ζ_α are the coordinates along the phase surface $\theta = \text{const}$, and κ is the Jacobian of transformation from x_α, t to θ, ζ_α . In the first approximation we may regard $\kappa, \theta_{,\alpha}$ and $\theta_{,t}$ in each strip as independent from θ . Therefore we obtain the same problem in each strip at the first step of the variational-asymptotic procedure [8]: find the extremal of the functional

$$\bar{I}_0[\psi_i] = \int_0^{2\pi} L(\psi_i, \psi_{i,\theta}, \theta_{,\alpha}, \psi_{i,\theta}, \theta_{,t}) d\theta \quad (8.19)$$

among 2π -periodic functions $\psi_i(\theta)$. Since the quantities $k_\alpha = \theta_{,\alpha}$ and $-\omega = \theta_{,t}$ change little within one strip, they are regarded as constants in the functional (8.19). The Euler-Lagrange equation of this functional is a system of n nonlinear second-order ordinary differential equations. Its solutions contain $2n$ arbitrary constants: n of them is determined from the conditions that $\psi_i(\theta)$ are 2π -periodic functions, the other n conditions can be chosen by fixing the amplitudes a_i as follows: $\max \psi_i = |a_i|$, where a_i are arbitrary real constants.⁷ We call this variational problem strip problem.

Let us denote by $2\pi\bar{L}$ the value of the functional (8.19) at its extremal. The quantity \bar{L} is a function of $a_i, \theta_{,\alpha}$ and $\theta_{,t}$. The sum (8.18), as $\lambda/\Lambda \rightarrow 0$ and $\tau/T \rightarrow 0$, can again be replaced by the integral

$$\iint_R \bar{L}(a_i, \theta_{,x}, \theta_{,t}) dx dt. \quad (8.20)$$

Euler-Lagrange's equations of the average functional (8.20) read

$$\frac{\partial \bar{L}}{\partial a_i} = 0, \quad \frac{\partial}{\partial t} \frac{\partial \bar{L}}{\partial \theta_{,t}} + \frac{\partial}{\partial x_\alpha} \frac{\partial \bar{L}}{\partial \theta_{,\alpha}} = 0. \quad (8.21)$$

We will see that equations (8.21)₁ express the solvability condition for the strip problem leading to the nonlinear dispersion relation, while (8.21)₂ is equivalent to the equation of energy propagation.

Strip Problems. As an example let us consider the strip problem for the nonlinear Klein-Gordon equation, whose Lagrangian is given by

$$L = \frac{1}{2} u_{,t}^2 - \frac{1}{2} u_{,x}^2 - U(u).$$

In this case the average Lagrangian must be calculated according to

⁷ This choice is dictated by the phase portrait of the strip problem. We will see later that, in some cases, the constants must be chosen by fixing the slopes rather than the amplitudes.

$$\bar{L} = \frac{1}{2\pi} \min_{\max \psi=a} \int_0^{2\pi} \left[\frac{1}{2}(\omega^2 - k^2)\psi'^2 - U(\psi) \right] d\theta,$$

where $\omega = -\theta_{,t}$ and $k = \theta_{,x}$ are regarded as constants. We use the first integral

$$\frac{1}{2}(\omega^2 - k^2)\psi'^2 + U(\psi) = U(a) = h$$

to express \bar{L} in the form

$$\bar{L} = \frac{1}{2\pi} \int_0^{2\pi} (\omega^2 - k^2)\psi'^2 d\theta - h.$$

Changing the variable $\theta \rightarrow \psi$, we obtain finally

$$\bar{L} = \frac{1}{2\pi} (\omega^2 - k^2) \int_0^{2\pi} \psi' d\psi - h = \frac{1}{2\pi} \sqrt{2(\omega^2 - k^2)} \oint \sqrt{h - U(\psi)} d\psi - h. \quad (8.22)$$

The contour integral in (8.22) denotes the integral over a complete oscillation of ψ from b , with $U(b) = U(a)$, up to a and back, so it is equal to twice the integral from b to a because the sign of the square root has to be changed appropriately in the two parts of the contour. This integral may also be interpreted as the contour integral around a cut from b to a in the complex ψ -plane, where ψ plays the role of the variable of integration.

Now let us consider the average variational problem (8.20) in which \bar{L} is given by (8.22) with $h = U(a)$, $\omega = -\theta_{,t}$, and $k = \theta_{,x}$. Euler-Lagrange's equations of this problem read

$$\frac{\partial \bar{L}}{\partial h} \frac{dh}{da} = 0, \quad -\frac{\partial}{\partial t} \frac{\partial \bar{L}}{\partial \omega} + \frac{\partial}{\partial x_\alpha} \frac{\partial \bar{L}}{\partial k} = 0. \quad (8.23)$$

It is easy to see that differentiation of \bar{L} with respect to h gives

$$\frac{\partial \bar{L}}{\partial h} = \frac{1}{2\pi} \frac{\sqrt{\omega^2 - k^2}}{\sqrt{2}} \oint \frac{d\psi}{\sqrt{h - U(\psi)}} - 1.$$

Thus, the first equation of (8.23) is nothing else but the nonlinear dispersion relation (8.5) for the nonlinear Klein-Gordon equation. Together with the kinematic relation

$$k_{,t} + \omega_{,x} = 0, \quad (8.24)$$

they form a system of nonlinear coupled equations describing the amplitude modulations.

The strip problems for two or more unknown functions reduce to the problem of finding the nonlinear normal modes already solved in Chapter 7. Consider for example the wave equations which are Euler-Lagrange's equations of the following Lagrangian

$$L = \frac{1}{2}(u_{1,t}^2 + u_{2,t}^2) - \frac{1}{2}(u_{1,x}^2 + u_{2,x}^2) - U(u_1, u_2).$$

This Lagrangian arises in the problem of coupled vibrations of two pre-stretched strings along which nonlinear springs with the cubic nonlinearity are attached at close intervals, where function $U(u_1, u_2)$ describes the potential energy density of the springs. The strip problem becomes: find the 2π -periodic functions ψ_1 and ψ_2 which minimize the following functional

$$I_0[\psi_1, \psi_2] = \int_0^{2\pi} \frac{1}{2}(\omega^2 - k^2)(\psi_{1,\theta}^2 + \psi_{2,\theta}^2) - U(\psi_1, \psi_2) d\theta.$$

Denoting $\omega^2 - k^2 = m$, we write the corresponding Lagrange's equations in the form

$$m\psi_{1,\theta\theta} = -\frac{\partial U}{\partial \psi_1}, \quad m\psi_{2,\theta\theta} = -\frac{\partial U}{\partial \psi_2}.$$

This is nothing else but equations (7.7) studied in connection with the nonlinear normal modes in Section 7.2. If we seek the nonlinear normal modes as 2π -periodic solutions by assuming ψ_2 as a function of ψ_1 , then the problem reduces to solving the modal equation

$$2(h - U)\psi_2'' + (1 + \psi_2'^2)\left(\frac{\partial U}{\partial \psi_2} - \psi_2' \frac{\partial U}{\partial \psi_1}\right) = 0,$$

which is the ordinary differential equation of second order, where the prime denotes the derivative with respect to ψ_1 and h is a constant in the first integral

$$\frac{1}{2}m\psi_{1,\theta}^2(1 + \psi_2'^2) + U(\psi_1, \psi_2) = h.$$

Particularly, if $U(\psi_1, \psi_2)$ equals

$$U(\psi_1, \psi_2) = \frac{1}{2}[\psi_1^2 + \frac{\alpha}{2}\psi_1^4 + \psi_2^2 + \frac{\alpha}{2}\psi_2^4 + \frac{\beta}{2}(\psi_2 - \psi_1)^4],$$

then the normal modes become similar modes $\psi_2 = c\psi_1$, with

$$c = 1, -1, 1 - \frac{1}{2\kappa} \pm \frac{1}{\kappa} \sqrt{1/4 - \kappa},$$

where $\kappa = \beta/\alpha$ is the coupling factor. The strip problem reduces then to the problem with one unknown function admitting the analytical solution (see exercise 8.7). Thus, for $\kappa < 1/4$, there are two additional normal modes bifurcated out of the antisymmetric mode $\psi_2 = -\psi_1$ (vibrations in counter-phases) at $\kappa = 1/4$. This indicates the bifurcation of amplitude modulations in our original problem of wave propagation.

Hamilton's Equations for the Strip Problem. It is quite straightforward to transform Lagrange's equations of the strip problem to the equivalent Hamilton's form. We take the differential of the Lagrange function $\Lambda(\psi_i, \psi_i') = L(\psi_i, k_\alpha \psi_i', -\omega \psi_i')$ as function of ψ_i and $\psi_i' = \psi_{i,\theta}$

$$d\Lambda = \sum_{i=1}^n \left(\frac{\partial \Lambda}{\partial \psi_i} d\psi_i + \frac{\partial \Lambda}{\partial \psi'_i} d\psi'_i \right).$$

We introduce new variables $p_i = \partial \Lambda / \partial \psi'_i$ and the Hamilton function $H(\psi_i, p_i)$ as Legendre's transform of $\Lambda(\psi_i, \psi'_i)$ with respect to ψ'_i

$$H(\psi_i, p_i) = \sum_{i=1}^n p_i \psi'_i - \Lambda.$$

The Lagrange's equations of the strip problem are equivalent to

$$\psi'_i = \frac{\partial H}{\partial p_i}, \quad p'_i = -\frac{\partial H}{\partial \psi_i},$$

for all $i = 1, 2, \dots, n$. These replace n differential equations of second order by the system of $2n$ differential equations of first order. The functional (8.19) may now be written as

$$\bar{I}_0[\psi_i, p_i] = \int_0^{2\pi} \left[\sum_{i=1}^n p_i \psi'_i - H(\psi_i, p_i) \right] d\theta.$$

It is easy to check that the extremal of this functional among 2π -periodic functions $\psi_i(\theta)$ and $p_i(\theta)$ corresponds to the extremal of the functional (8.19). If the Hamilton function does not depend explicitly on θ , then the first integral follows

$$H(\psi_i, p_i) = h.$$

Adiabatic Invariants. If we consider wave propagation in weakly inhomogeneous media or wave propagation under some external forces which change slowly in space and time, then the Lagrangian depends explicitly on \mathbf{x} and t . This is quite similar to the vibrations of a non-autonomous mechanical system where one parameter of the system changes slowly in time.⁸ It turns out that some quantities, called adiabatic invariants, remain constant in this situation. The finding of these adiabatic invariants can be done by the variational-asymptotic method. For simplicity let us consider a nonlinear oscillator with one degree of freedom $q(t)$ and one slowly varying parameter $\lambda(t)$. Hamilton's variational principle states that

$$\delta \int_{t_0}^{t_1} L(q, \dot{q}, \lambda) dt = 0.$$

We first calculate the average Lagrange function for the periodic motion with λ held fixed. Since the period is $T = 2\pi/\omega$, we have

$$\bar{L} = \frac{\omega}{2\pi} \int_0^T L(q, \dot{q}, \lambda) dt.$$

⁸ For example, the vibration of a pendulum with slowly changing length.

With $\lambda = \text{const}$ the conservation of energy

$$\dot{q} \frac{\partial L}{\partial \dot{q}} - L = h$$

holds true. This equation may be solved with respect to \dot{q} so that the generalized momentum $p = \partial L / \partial \dot{q}$ can be expressed as

$$p = p(q, h, \lambda).$$

Using the same conservation of energy we may calculate the average Lagrange function as follows

$$\bar{L} = \frac{\omega}{2\pi} \int_0^T p \dot{q} dt - h = \frac{\omega}{2\pi} \oint p(q, h, \lambda) dq - h, \tag{8.25}$$

where $\oint p dq$ means the integral over one complete period of vibration which corresponds to the close orbit in the phase plane. We now allow a slow change of λ in time, and consider the average variational problem obtained as the particular case of (8.20)

$$\delta \int_{t_0}^{t_1} \bar{L}(a, \theta_t, \lambda) dt = 0.$$

Here $\theta_t = -\omega$, with ω being the frequency of vibration. Lagrange's equations of this variational problem read

$$\frac{\partial \bar{L}}{\partial a} = \frac{\partial \bar{L}}{\partial h} \frac{dh}{da} = 0, \quad \frac{\partial}{\partial t} \frac{\partial \bar{L}}{\partial \theta_t} = -\frac{\partial}{\partial t} \frac{\partial \bar{L}}{\partial \omega} = 0. \tag{8.26}$$

The first equation is nothing else but the frequency-amplitude equation of this non-linear oscillator (see exercise 8.8). The second equation leads to the conservation of the action variable

$$I(\omega, h) = \frac{\partial \bar{L}}{\partial \omega} = \frac{1}{2\pi} \oint p(q, h, \lambda) dq = \text{const},$$

which is just the classical result of the adiabatic invariant [5]. From (8.25) and (8.26) the period is given by

$$T = \frac{2\pi}{\omega} = \frac{\partial I}{\partial h},$$

which is also classical.

From this analysis we see that for waves the quantities $\partial \bar{L} / \partial \omega$ and $\partial \bar{L} / \partial k_\alpha$ are akin to the adiabatic invariants with respect to time and space. If the wave packet is uniform in space but responding to changes of the medium in time, then we must have

$$\frac{\partial \bar{L}}{\partial \omega} = \text{const}.$$

Alternatively, for a wave packet of fixed frequency moving in a weakly inhomogeneous medium dependent only on one coordinate x , we have

$$\frac{\partial \bar{L}}{\partial k} = \text{const.}$$

In general, modulations in space and time balance according to the equation

$$\frac{\partial}{\partial t} \frac{\partial \bar{L}}{\partial \omega} - \frac{\partial}{\partial x_\alpha} \frac{\partial \bar{L}}{\partial k_\alpha} = 0,$$

which describes the propagation of the amplitude modulations.

Effect of Damping. If the medium in which waves propagate possesses some viscosity, then the energy is not only transported by the waves, but also dissipated during the process of wave propagation. The average equations of amplitude modulations can be obtained by the variational-asymptotic method for the case of small dissipation. Let us illustrate this on the example of the nonlinear Klein-Gordon equation with a small resistance force

$$u_{,tt} - u_{,xx} + U'(u) = f(u, u_{,t}),$$

where $f(u, u_{,t}) = -\partial D / \partial u_{,t}$ is a small term of the order $(\tau/T)u$, with $D(u, u_{,t})$ being the dissipation function assumed as homogeneous of order 2 with respect to $u_{,t}$. It is easy to show that this equation can be obtained from the variational equation

$$\delta \iint [\frac{1}{2}u_{,t}^2 - \frac{1}{2}u_{,x}^2 - U(u)] dxdt + \iint f(u, u_{,t}) \delta u dxdt = 0. \tag{8.27}$$

In the first step of the variational-asymptotic method we neglect the last term in (8.27) as small compared with other terms and seek for the solution in the form

$$u = u_0(\theta, x, t),$$

where u_0 and θ behave in the same way as in (8.15). So, the analysis provided in the first paragraph of this Section leads to the following strip problem

$$\min_{\max u_0=a} \langle \frac{1}{2}(\omega^2 - k^2)u_{0,\theta}^2 - U(u_0) \rangle,$$

where $\langle \cdot \rangle = \frac{1}{2\pi} \int_0^{2\pi} \cdot d\theta$ denotes the averaging over the strip, and where $\omega = -\theta_{,t}$ and $k = \theta_{,x}$ are treated as constants. Let $\bar{L}(a, \omega, k)$ be the minimum and $u_0 = \psi(a, \theta)$ the corresponding minimizer of this strip problem.

It can be shown that the second step brings correction of the order $u_1 \simeq (\tau/T)u_0$ in u and corrections of the order $(\tau/T)^2 u_0^2$ in the average Lagrangian and dissipation causing no influence on the average equations for a and θ .

To find the average equations let us substitute $u = \psi(a, \theta)$ into the original variational equation (8.27) and keep the asymptotically principal terms up to the order

$(\tau/T)\psi^2$ of smallness. Replacing the sums over the strips by the integrals in the limit $\lambda/\Lambda \rightarrow 0$ and $\tau/T \rightarrow 0$, we obtain

$$\delta \iint \bar{L}(a, -\theta_t, \theta_x) dx dt + \iint \langle f(\psi, -\psi_{,\theta}\omega) \delta\psi(a, \theta) \rangle dx dt = 0.$$

Substitution of $\delta\psi = \psi_{,a}\delta a + \psi_{,\theta}\delta\theta$ into this equation yields

$$\delta \iint \bar{L}(a, -\theta_t, \theta_x) dx dt + \iint \langle f(\psi, -\psi_{,\theta}\omega) (\psi_{,a}\delta a + \psi_{,\theta}\delta\theta) \rangle dx dt = 0.$$

It is easy to see that the term containing δa in the second integral brings just a small correction to the dispersion relation, so it can be neglected. Since the dissipation function $D(u, u_t)$ is a homogeneous function of second order with respect to u_t ,

$$\langle f(\psi, -\psi_{,\theta}\omega) \psi_{,\theta} \delta\theta \rangle = \frac{2}{\omega} \langle D(\psi, -\psi_{,\theta}\omega) \rangle \delta\theta = \frac{2}{\omega} \bar{D} \delta\theta,$$

where \bar{D} is the average dissipation function. Thus, the average variational equation reads

$$\delta \iint \bar{L}(a, -\theta_t, \theta_x) dx dt + \iint \frac{2}{\omega} \bar{D} \delta\theta dx dt = 0. \tag{8.28}$$

Varying equation (8.28) with respect to a , we obtain

$$\frac{\partial \bar{L}}{\partial a} = 0,$$

which shows that the dispersion relation remains exactly the same as in the case without dissipation. Varying (8.28) with respect to θ , we derive the following equation

$$\frac{\partial}{\partial t} \frac{\partial \bar{L}}{\partial \omega} - \frac{\partial}{\partial x} \frac{\partial \bar{L}}{\partial k} = -\frac{2}{\omega} \bar{D}.$$

This equation shows the loss in wave action due to dissipation. We see also that the term on the right-hand side must be maintained because it is of the same order of smallness as the terms standing on the left-hand side. The energy balance equation, which can easily be obtained from here, reads

$$(\omega \bar{L}_{,\omega} - \bar{L})_t - (\omega \bar{L}_{,k})_x = -2\bar{D}.$$

We see that some portion of energy is transported by the energy flux $-\omega \bar{L}_{,k}$, and some is simply dissipated against the resistance due to viscosity. To complete the system of average equations of amplitude modulations we have to include also

$$k_t + \omega_x = 0,$$

which is simply the kinematic relation. It is easy to generalize this result to higher dimensions and more unknown functions.

8.4 Amplitude and Slope Modulation

This Section studies the theory of amplitude (or slope) modulation of nonlinear dispersive waves and presents some of its selected applications.⁹

The Near-Linear Case. As we know already from the previous Section, the amplitude modulation in 1-D case is described by the equations

$$\begin{aligned} \bar{L}_{,a} &= 0, & k_{,t} + \omega_{,x} &= 0, \\ (\bar{L}_{,\omega})_{,t} - (\bar{L}_{,k})_{,x} &= 0. \end{aligned} \tag{8.29}$$

The first equation corresponds to the nonlinear dispersion relation. The near-linear theory is obtained by expanding \bar{L} in powers of the amplitude. This expansion may be taken as

$$\bar{L} = G(\omega, k)a^2 + G_2(\omega, k)a^4 + \dots$$

Computing $\bar{L}_{,a}$, we may solve (8.29)₁ with respect to ω to have explicitly

$$\omega = \Omega(k, a) = \Omega_0(k) + \Omega_2(k)a^2 + \dots, \tag{8.30}$$

where

$$G(\Omega_0, k) = 0, \quad \Omega_2(k) = -\frac{2G_2(\Omega_0(k), k)}{G_{,\omega}(\Omega_0(k), k)}.$$

We see that the dispersion relation $\omega = \Omega(k, a)$ couples the remaining equations (8.29). With (8.30) equation (8.29)₂ becomes

$$k_{,t} + [\Omega'_0(k) + \Omega'_2(k)a^2]k_{,x} + \Omega_2(k)(a^2)_{,x} = 0.$$

The important coupling term is $\Omega_2(k)(a^2)_{,x}$ because it leads to the correction $O(a)$ to the characteristic velocities. The other new term $\Omega'_2(k)a^2k_{,x}$ merely contributes the correction of order $O(a^2)$. Concerning (8.29)₃ the inclusion of terms of order a^4 would provide corrections of order a^2 to the existing terms. Therefore in the first assessment of nonlinear effects we leave in the dispersion relation only one additional term $\Omega_2(k)a^2$ and consider

$$\begin{aligned} k_{,t} + \Omega'_0(k)k_{,x} + \Omega_2(k)(a^2)_{,x} &= 0, \\ (a^2)_{,t} + (\Omega'_0(k)a^2)_{,x} &= 0. \end{aligned} \tag{8.31}$$

This system of equations admits the characteristic form. To see this let us multiply the first equation by p and the second by q and then add them together. The resulting equation is

$$[pk_{,t} + (p\Omega'_0 + q\Omega''_0 a^2)k_{,x}] + [q(a^2)_{,t} + (p\Omega_2 + q\Omega'_0)(a^2)_{,x}] = 0.$$

⁹ Various applications of the theory of amplitude modulations to laser beams and water waves can be found in [53].

We want to choose p and q so that the expressions in the square brackets represent full derivatives of k and a^2 along the *same* characteristic curve. This is possible if

$$\frac{p}{p\Omega'_0 + q\Omega''_0 a^2} = \frac{q}{p\Omega_2 + q\Omega'_0} \Rightarrow p = \pm \sqrt{\frac{\Omega''_0(k)}{\Omega_2(k)}} a q.$$

We may choose $p = 1$. Then, the characteristic form of (8.31) read

$$\frac{1}{2} \sqrt{\frac{\Omega''_0(k)}{\Omega_2(k)}} (\text{sign} \Omega''_0(k)) dk \pm da = 0$$

on the characteristics

$$\frac{dx}{dt} = \Omega'_0(k) \pm \sqrt{\Omega_2(k)\Omega''_0(k)} a. \tag{8.32}$$

This simple near-linear version of the theory of amplitude modulation already shows some interesting results. In the case $\Omega_2(k)\Omega''_0(k) > 0$, the characteristics are real and the system is hyperbolic. The double characteristic velocity splits under the nonlinear correction and we have the two velocities given by (8.32). In general, an initial disturbance or modulating source will introduce disturbances on both families of characteristics. If the initial disturbance is concentrated in a compact domain, it will eventually split into two.

When $\Omega_2(k)\Omega''_0(k) < 0$, the characteristics are imaginary and the system is elliptic. This leads to ill-posed problems in the wave propagation context. It means that small perturbations will grow in time leading to the instability of the wave packet. This case turns out to be not rare. For example, the Klein-Gordon equation with $U(\varphi) = \varphi^2/2 + \alpha\varphi^4/4$, α being small, gives

$$\Omega_0 = \sqrt{1+k^2}, \quad \Omega_2 = \frac{3}{8}\alpha/\sqrt{1+k^2}.$$

Thus, the sign of $\Omega_2(k)\Omega''_0(k)$ coincides with the sign of α ; the modulation equations are hyperbolic for $\alpha > 0$ and elliptic for $\alpha < 0$. For waves of small up to moderate amplitudes, the Sine-Gordon equation has $\alpha = -1/6 > 0$. Thus, the waves of small amplitudes governed by the Sine-Gordon equation are unstable. This consequence of the near-linear theory, already non-trivial, is not easy to obtain by the direct stability analysis of the Sine-Gordon equation.

Characteristic Form of the Equations of Amplitude Modulation. Also the governing equations (8.29) of fully nonlinear theory of amplitude modulation admit the characteristic form. This can be obtained by doing Legendre transform of the average Lagrangian $\bar{L}(a, k, \omega)$ with respect to ω

$$H(a, k, I) = \omega \bar{L}_{,\omega} - \bar{L} = \omega I - \bar{L},$$

where $I = \bar{L}_{,\omega}$. Due to the property of Legendre transform we have

$$\bar{L}_{,k} = -H_{,k} = -J, \quad \omega = H_{,I}. \quad (8.33)$$

Therefore equations (8.29)_{2,3} become

$$\begin{aligned} k_{,I} + (H_{,I})_{,x} &= 0, \\ I_{,I} + (H_{,k})_{,x} &= 0. \end{aligned}$$

Recalling that $\bar{L}_{,a} = -H_{,a} = 0$ due to the first equation of (8.29), we rewrite the above equations in the vector form as

$$\mathbf{v}_{,I} + \mathbf{M}\mathbf{v}_{,x} = 0,$$

where

$$\mathbf{v} = \begin{pmatrix} k \\ I \end{pmatrix}, \quad \mathbf{M} = \begin{pmatrix} H_{,Ik} & H_{,II} \\ H_{,kk} & H_{,kI} \end{pmatrix}.$$

Proceeding similarly as for equations (8.31) we get the characteristic equations

$$\sqrt{H_{,kk}} dk \pm \sqrt{H_{,II}} dI = 0$$

on the characteristics

$$\frac{dx}{dt} = H_{Ik} \pm \sqrt{H_{,kk}H_{,II}}.$$

If the characteristics are real, then the system (8.29) is hyperbolic. In the opposite case the system is elliptic. The type of the equations depends thus on the sign of $H_{,kk}H_{,II}$.

Slope Modulation of Waves Governed by Sine-Gordon Equation. The phase portrait of the strip problem for the Sine-Gordon equation

$$u_{,II} - u_{,xx} = \sin u \quad (8.34)$$

exhibits in the subsonic regime quite different behavior than that of non-linear Klein-Gordon equation with $\alpha > 0$. This behavior dictates the fixing of slope rather than amplitude for its solution. To see this, let us start from the variational formulation of (8.34): find the extremal of the functional

$$I[u(x,t)] = \iint \left[\frac{1}{2}u_{,t}^2 - \frac{1}{2}u_{,x}^2 - (1 - \cos u) \right] dx dt.$$

The variational asymptotic procedure using the multi-scale Ansatz $u = \psi(\theta, x, t)$, developed in the previous Section, leads to the following strip problem: find the extremal of the functional

$$I_0[\psi(\theta)] = \frac{1}{2\pi} \int_0^{2\pi} \left[\frac{1}{2}(\omega^2 - k^2)\psi_{,\theta}^2 - (1 - \cos \psi) \right] d\theta$$

among functions $\psi(\theta)$ satisfying the conditions

$$\psi(2\pi) = \psi(0) + 2\pi, \quad \psi_{,\theta}(2\pi) = \psi_{,\theta}(0). \tag{8.35}$$

In this strip problem, the wave number $k = \theta_{,x}$ and the frequency $\omega = -\theta_{,t}$ are regarded as constants. Since we are interested in the subsonic regime $\omega^2 < k^2$, it is convenient to change the sign of this functional which does not influence Euler-Lagrange's equation. Thus, we need to find the extremal of the functional

$$\frac{1}{2\pi} \int_0^{2\pi} \left[\frac{1}{2} m \psi_{,\theta}^2 - (\cos \psi - 1) \right] d\theta \tag{8.36}$$

among functions $\psi(\theta)$ satisfying the conditions (8.35), where $m = k^2 - \omega^2$. Variational problem (8.36) possesses an obvious first integral

$$\frac{1}{2} m \psi_{,\theta}^2 + (\cos \psi - 1) = h$$

resembling that of the mathematical pendulum in the upward position. The corresponding phase portrait is plotted in Fig. 8.7. Looking at this phase portrait, we see that the determination of the phase curves as extremals of (8.36) outside the separatrix requires, in addition to (8.35), the fixing of the maximal slope of ψ as follows:

$$\max_{\theta} |\psi_{,\theta}| = p, \tag{8.37}$$

where p is an arbitrary real and positive number.

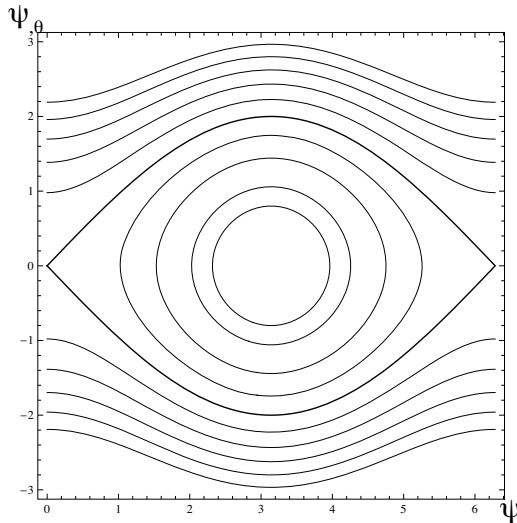

Fig. 8.7 Phase portrait of a pendulum with $m = 1$

Let us denote by \bar{L} the average Lagrangian (extremum of functional (8.36)) which is a function of $p, k = \theta_{,x}$, and $\omega = -\theta_{,t}$. The sum of integrals over the strips, as the wave length goes to zero, can again be replaced by the integral

$$\bar{I}_0[p, \theta] = \iint \bar{L}(p, \theta_{,x}, -\theta_{,t}) dx dt.$$

Euler-Lagrange's equations of this average functional read

$$\frac{\partial \bar{L}}{\partial p} = \frac{\partial \bar{L}}{\partial h} \frac{\partial h}{\partial p} = 0, \quad \frac{\partial}{\partial t} \frac{\partial \bar{L}}{\partial \omega} - \frac{\partial}{\partial x} \frac{\partial \bar{L}}{\partial k} = 0.$$

The first equation yields the nonlinear dispersion relation, while the second equation is the equation of slope modulation.

Using the above integral, we find the solution in terms of elliptic functions and then the average Lagrangian according to

$$\bar{L} = \frac{1}{2\pi} \int_0^{2\pi} m \psi_{,\theta}^2 d\theta - h = \frac{1}{2\pi} \int_0^{2\pi} m \psi_{,\theta} d\psi - h.$$

Now, to find the explicit dependence of \bar{L} on p and m we use condition (8.37). Since the maximal slope of ψ is achieved at $\theta = \pi$ (see Fig. 8.7), this condition implies that $\frac{1}{2}mp^2 - 2 = h$. We require $h \geq 0$, so $p \geq 2/\sqrt{m}$. Then, from the first integral it follows

$$\bar{L}(p, k, \omega) = \frac{\sqrt{2m}}{2\pi} f(h) - h, \quad (8.38)$$

where $f(h)$ is the function expressed in terms of the complete elliptic integral

$$f(h) = \int_0^{2\pi} \sqrt{h - \cos \psi + 1} d\psi = 2[\sqrt{h}E(-2/h) + \sqrt{2+h}E(2/(2+h))].$$

According to (8.38) the dispersion relation reads

$$\frac{\sqrt{2m}}{2\pi} f'(h) - 1 = 0. \quad (8.39)$$

Keeping in mind this dispersion relation, let us find the derivatives

$$\frac{\partial \bar{L}}{\partial k} = \frac{\sqrt{2}}{2\pi} \frac{m_{,k}}{2\sqrt{m}} f(h) + \left(\frac{\sqrt{2m}}{2\pi} f'(h) - 1 \right) h_{,k} = \frac{\sqrt{2}}{2\pi} \frac{k}{\sqrt{m}} f(h),$$

and

$$\frac{\partial \bar{L}}{\partial \omega} = \frac{\sqrt{2}}{2\pi} \frac{m_{,\omega}}{2\sqrt{m}} f(h) + \left(\frac{\sqrt{2m}}{2\pi} f'(h) - 1 \right) h_{,\omega} = -\frac{\sqrt{2}}{2\pi} \frac{\omega}{\sqrt{m}} f(h),$$

where the last terms in these formulas vanish due to (8.39). Now we substitute these derivatives into the equation of slope modulation and compute the partial derivatives with respect to x and t . After some algebra we get

$$\frac{f(h)}{m\sqrt{m}} \mathcal{S}_1(\omega, k) + \frac{2\pi}{\sqrt{2m}} q(k^2 k_{,x} - 2k\omega\omega_{,x} - \omega^2\omega_{,t}) + \frac{\pi}{\sqrt{2}}(kq_{,x} + \omega q_{,t}) = 0, \tag{8.40}$$

where $q = p^2$ and

$$\mathcal{S}_1(\omega, k) = k^2\omega_{,t} - \omega^2 k_{,x} + 2k\omega\omega_{,x}.$$

The equation of slope modulation in terms of θ is obtained if we replace in (8.40) $k = \theta_{,x}$ and $\omega = -\theta_{,t}$. Equivalently, equation (8.40) can be solved together with the consistency condition

$$\omega_{,x} + k_{,t} = 0.$$

Asymptotic Solution to the Equation of Slope Modulation. From numerous numerical simulations and n -soliton exact solutions of the Sine-Gordon equation we know that, at large time, the solitons become non-interacting and propagating along the straight lines $x/t = \text{const}$. Since the phase increases by 2π when one soliton is passed, let us look for the phase in the following form

$$\theta(x, t) = g(\xi(x, t)), \quad \xi(x, t) = x/t.$$

According to this Ansatz we have

$$\begin{aligned} k &= \theta_{,x} = g'(\xi) \frac{1}{t}, & \omega &= -\theta_{,t} = g'(\xi) \frac{x}{t^2}, & k_{,x} &= g''(\xi) \frac{1}{t^2}, \\ \omega_{,x} &= g''(\xi) \frac{x}{t^3} + g'(\xi) \frac{1}{t^2}, & \omega_{,t} &= -\left(g''(\xi) \frac{x^2}{t^4} + 2g'(\xi) \frac{x}{t^3} \right). \end{aligned} \tag{8.41}$$

It is now straightforward to check that $\mathcal{S}_1(\omega, k) = 0$, so the equation of slope modulation takes the form

$$2q\mathcal{S}_2(\omega, k) + m(kq_{,x} + \omega q_{,t}) = 0, \tag{8.42}$$

where

$$\begin{aligned} \mathcal{S}_2(\omega, k) &= k^2 k_{,x} - 2k\omega\omega_{,x} - \omega^2\omega_{,t} \\ &= g'(\xi)^2 g''(\xi) \left(\frac{t^2 - x^2}{t^4} \right)^2 - 2g'(\xi)^3 \frac{x}{t^5} \left(\frac{t^2 - x^2}{t^2} \right), \end{aligned}$$

and

$$m = k^2 - \omega^2 = g'(\xi)^2 \frac{t^2 - x^2}{t^4}. \tag{8.43}$$

Substituting these formulas into (8.42), we obtain

$$2q[g''(\xi)(t^2 - x^2) - 2g'(\xi)xt] + g'(\xi)t^2(tq_{,x} + xq_{,t}) = 0. \tag{8.44}$$

Equation (8.44) is the partial differential equation of first order which can be solved by the method of characteristics. The characteristic curves are determined by the equation

$$\frac{dx}{dt} = \frac{t}{x},$$

yielding

$$t^2 - x^2 = \alpha > 0.$$

Along any characteristic curve (8.44) becomes an ordinary differential equation

$$\frac{dQ_\alpha}{dt} + 2A_\alpha(t)Q_\alpha(t) = 0, \quad (8.45)$$

where α remains constant along each curve, $Q_\alpha(t) = q(x_\alpha(t), t)$, and

$$A_\alpha(t) = \frac{\alpha}{x_\alpha(t)t^2} \frac{g''(\xi_\alpha(t))}{g'(\xi_\alpha(t))} - \frac{2}{t}, \quad \xi_\alpha(t) = \frac{x_\alpha(t)}{t}, \quad x_\alpha(t) = \pm \sqrt{t^2 - \alpha}.$$

A standard integration of (8.45) leads to

$$Q_\alpha(t) = C(\alpha)^2 \frac{t^4}{g'(\xi_\alpha(t))^2},$$

with $C(\alpha)$ being a function of α . Turning back to the original coordinates x and t , we obtain

$$q(x, t) = C(t^2 - x^2)^2 \frac{t^4}{g'(\xi(x, t))^2}, \quad \xi(x, t) = \frac{x}{t},$$

and thus,

$$p(x, t) = \sqrt{q(x, t)} = C(t^2 - x^2) \frac{t^2}{g'(\xi(x, t))}. \quad (8.46)$$

As $g(\xi)$ describes the phase, function $g'(\xi)$ can be identified with $2\pi\rho(\xi)$, where $\rho(\xi)$ is the density of solitons (or the number of solitons per unit length).

The unknown function $C(t^2 - x^2)$ should be determined from the dispersion relation (8.39). Using the solution given by (8.46) and formula (8.43) for m , we obtain

$$h = \frac{1}{2}mp^2 - 2 = \frac{1}{2}(t^2 - x^2)C(t^2 - x^2)^2 - 2.$$

Since m goes to zero as t goes to infinity, the dispersion relation is fulfilled at large time if and only if h goes to zero.¹⁰ Thus,

$$C(t^2 - x^2) = \frac{2}{\sqrt{t^2 - x^2}},$$

and the final asymptotic formula for the slope reads

¹⁰ Strictly speaking, the exact fulfillment of the dispersion relation is warranted if h is of the order $m/2$ as $t \rightarrow \infty$, but this does not affect the asymptotically leading term for p .

$$p(x,t) = \frac{2t^2}{g'(\xi(x,t))\sqrt{t^2 - x^2}}. \tag{8.47}$$

Comparison with the Exact Solution. Let us compare the asymptotic solution (8.47) with the exact solution of Sine-Gordon equation obtained by the inverse scattering transform. It turns out that the exact solution of Sine-Gordon equation is intimately related to that of KdV equation. Note, however, that while the exact solution of KdV equation is given explicitly, the solution of Sine-Gordon equation is only obtainable through its slope u_x . It is convenient to solve the Sine-Gordon equation in cone coordinates

$$X = \frac{1}{2}(x+t), \quad T = \frac{1}{2}(x-t). \tag{8.48}$$

Knowing the solution in X and T , the solution in the physical coordinates x and t can easily be found through a simple change of variables.

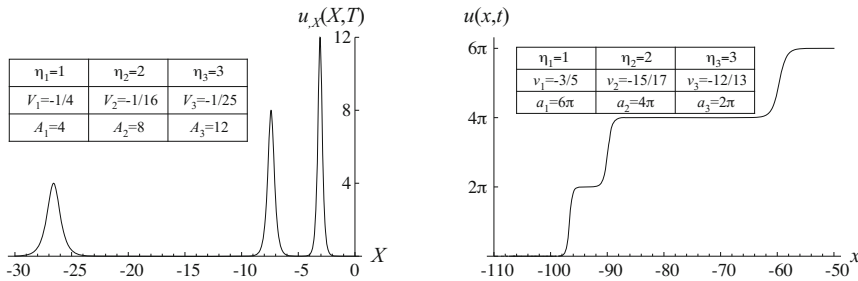

Fig. 8.8 3-soliton solution in physical coordinates (right) and its slope in cone coordinates (left). The eigenvalues, velocities and amplitudes of solitons and their slope are presented in the respective tables.

The solution reads (see [2])

$$\frac{1}{4} \left(\frac{\partial u}{\partial X} \right)^2 = \frac{\partial^2}{\partial X^2} \ln [\det (\mathbf{I} + \mathbf{A}\mathbf{A}^*)], \tag{8.49}$$

where

$$A_{lm} = \frac{\sqrt{c_l(T)c_m^*(T)}}{\zeta_l - \zeta_m^*} \exp [i(\zeta_l - \zeta_m^*)X],$$

and $c_l(T) = c_{l0} \exp(-iT/2\zeta_l)$. In the above formulas the asterisk is used to denote complex conjugate, while \mathbf{I} corresponds to the identity matrix. Constants c_{l0} characterize the initial state of solitons, while $\zeta_l = i\eta_l$ are different purely imaginary eigenvalues of the linear operator associated with the Sine-Gordon equation (see [1,2] for the setting of the eigenvalue problem). Distinct types of solutions of this equation are determined by different choices of pairs of eigenvalues ζ_l and $\zeta_m = \zeta_l^*$. We shall

concentrate on the traveling solitons, so the discrete and distinct imaginary eigenvalues are henceforth sufficient for our comparison purpose. Fig. 8.8 shows a 3-soliton solution (with solitons propagating to the left) together with its slope. By adding three other solitons (dislocations) propagating to the right and having the negative slope we may get the shape of the symmetrically propagating crack.

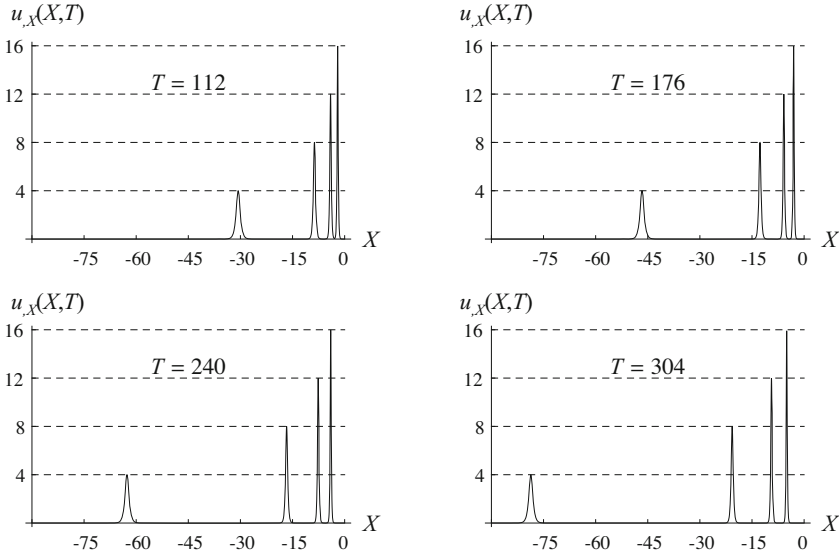

Fig. 8.9 Slope of 4-soliton solution in cone coordinates

As seen from Fig. 8.8 the slope of n -soliton solution to Sine-Gordon equation is itself n solitons having different shape. For this reason it makes sense to denote by V_j the velocities of solitons, which mark the velocities of points where maxima are achieved (centers of solitons), and by A_j the corresponding maxima. They are computed according to the following formulas

$$V_j = -\frac{1}{(2\eta_j)^2}, \quad A_j = 4\eta_j,$$

in which the minus sign indicates that the solitons travel to the left. The velocities of the j -th soliton in real space-time can be obtained through the change of variable (8.48)

$$v_j = -\frac{1 + V_j}{1 - V_j}.$$

In Fig. 8.9, several snap-shots at different time instants of the slope of 4-soliton solution constructed with the eigenvalues $\eta_j = j$, velocities $V_j = -1/4j^2$ and amplitudes $A_j = 4j$ are shown in cone coordinates.

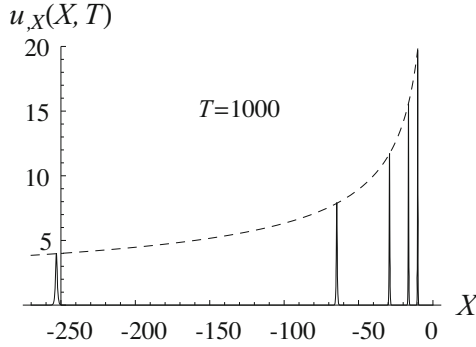

Fig. 8.10 Slope of 5-soliton in cone coordinates versus slope modulation: a) exact solution $u_{,X}$ (bold line), b) asymptotic law $2\sqrt{T/|X|}$ (dashed line)

To compare with the asymptotic solution obtained in the previous paragraph we note that for the slowly varying wave packet and to the first approximation,

$$u_{,X} = u_{,x} + u_{,t} = \psi_{,\theta}(k - \omega).$$

Since the maximum of $\psi_{,\theta}$ in one wavelength is chosen to be p , we expect that $p(k - \omega)$, with p being given by (8.47), should serve as the asymptotic envelope for the exact slope of soliton solution. Using (8.41) and (8.48), this quantity is given in cone coordinates by

$$p(k - \omega) = 2 \frac{t - x}{\sqrt{t^2 - x^2}} = 2\sqrt{-\frac{T}{X}} \tag{8.50}$$

Formula (8.50) holds true for solitons traveling to the left. For solitons traveling to the right and having the negative slope, the signs inside and in front of the square root should be changed. Note also that this asymptotic law which can be used to predict, among others, the shape of the propagating crack regarded as the wave packet of moving dislocations in crystals, is universal and does not depend on the distribution of solitons. Fig. 8.10 shows the slope of the exact 5-soliton solution and the graph of $2\sqrt{T/|X|}$ (see exercise 8.10). From this Figure it is seen that, at large time, the curve $2\sqrt{T/|X|}$ can serve as the asymptotic envelope for the slope of solitons.

8.5 Amplitude Modulations for KdV Equation

This last Section studies Whitham’s theory of amplitude modulations of waves governed by the KdV equation.

Derivation of Whitham’s Equations. In view of the exact analytical solution of KdV equation by the inverse scattering transform, it is tempting to develop the

theory of amplitude modulations for the KdV equation and to compare its asymptotic law with the exact solution. Unfortunately, in contrast to the Sine-Gordon equation the KdV equation does not admit a direct variational formulation. However, keeping in mind that the KdV equation is derivable from the Boussinesq's equation which admits a variational formulation, we may associate this equation with a variational principle by substituting $u = \eta_{,x}$ into (8.1) to get the equation

$$\eta_{,xt} + 6\eta_{,x}\eta_{,xx} + \eta_{,xxx} = 0.$$

The latter can be obtained from the stationarity of the following functional

$$I[\eta(x,t)] = \iint \left(-\frac{1}{2}\eta_{,t}\eta_{,x} - \eta_{,x}^3 + \frac{1}{2}\eta_{,xx}^2 \right) dxdt. \tag{8.51}$$

We shall use this indirect variational formulation through η to derive the equations of amplitude modulations for u . We look for the extremal of this variational problem in form of slowly varying wave packet

$$\eta(x,t) = \varphi(\theta, x, t) + \chi(x, t),$$

with φ a function of fast variable θ and slow variables x and t . We assume that φ is 2π -periodic with respect to θ . The fast variable θ , being itself a function of slow variables x and t , plays the role of the phase, with $\theta_{,x}$ and $-\theta_{,t}$ corresponding to the wave number k and the frequency ω , respectively. Besides, the derivative $\beta = \chi_{,x}$ accounts for the mean value of u over one θ -period. We calculate the partial derivatives of η in accordance with this Ansatz

$$\begin{aligned} \eta_{,x} &= \varphi_{,\theta}\theta_{,x} + \underline{\partial_x\varphi} + \chi_{,x}, & \eta_{,t} &= \varphi_{,\theta}\theta_{,t} + \underline{\partial_t\varphi} + \chi_{,t}, \\ \eta_{,xx} &= \varphi_{,\theta\theta}\theta_{,x}^2 + \underline{\varphi_{,\theta}\theta_{,xx}} + \underline{2\partial_x\varphi_{,\theta}\theta_{,x}} + \underline{\partial_x^2\varphi} + \underline{\chi_{,xx}}. \end{aligned}$$

Based on the assumptions similar to those in (8.17), one recognizes immediately that the underlined terms are negligibly small compared with their first respective terms. Besides, the wave number and the frequency change slowly in one wave length and one period. We assume further that the mean value $\beta = \chi_{,x}$ changes also slowly in one wavelength so that its derivative $\beta_{,x} = \chi_{,xx}$ can be neglected in the first approximation. Taking all these circumstances into account, the derivatives of η can approximately be replaced by

$$\eta_{,x} = \varphi_{,\theta}\theta_{,x} + \chi_{,x}, \quad \eta_{,t} = \varphi_{,\theta}\theta_{,t} + \chi_{,t}, \quad \eta_{,xx} = \varphi_{,\theta\theta}\theta_{,x}^2,$$

where $\gamma = -\chi_{,t}$ is assumed to change slowly in one period. Substituting these formulas into (8.51), we obtain the functional

$$I_0[\varphi, \theta] = \iint \left[-\frac{1}{2}(\varphi_{,\theta}\theta_{,t} + \chi_{,t})(\varphi_{,\theta}\theta_{,x} + \chi_{,x}) - (\varphi_{,\theta}\theta_{,x} + \beta)^2 + \frac{1}{2}\theta_{,x}^4\varphi_{,\theta\theta}^2 \right] dxdt.$$

In accordance with the method developed in Section 8.3, we formulate the strip problem as follows: find the extremal of the functional

$$\frac{1}{2\pi} \int_0^{2\pi} \left[\frac{1}{2}(\omega\varphi_{,\theta} + \gamma)(k\varphi_{,\theta} + \beta) - (k\varphi_{,\theta} + \beta)^3 + \frac{1}{2}k^4\varphi_{,\theta\theta}^2 \right] d\theta \quad (8.52)$$

among functions $\varphi(\theta)$ satisfying 2π -periodicity conditions

$$\varphi(2\pi) = \varphi(0), \quad \varphi_{,\theta}(2\pi) = \varphi_{,\theta}(0), \quad \varphi_{,\theta\theta}(2\pi) = \varphi_{,\theta\theta}(0).$$

In this strip problem k , ω , β , and γ are considered as constants. Let us denote by $c = \omega/k$ the phase velocity.

To reduce the order of the resulting differential equations, let us make a change of unknown function

$$\phi = k\varphi_{,\theta} + \beta.$$

It is natural to use this new unknown function in the strip problem because it represents the approximate solution of KdV equation. According to it we have

$$\varphi_{,\theta} = \frac{\phi - \beta}{k}, \quad \phi_{,\theta} = k\varphi_{,\theta\theta}.$$

As function $\varphi(\theta)$ is 2π -periodic, the introduced new function $\phi(\theta)$ should satisfy the constraint

$$\frac{1}{2\pi} \int_0^{2\pi} \phi d\theta = \frac{1}{2\pi} \int_0^{2\pi} (k\varphi_{,\theta} + \beta) d\theta = \beta. \quad (8.53)$$

Thus, we replace the functional (8.52) by

$$\begin{aligned} & \frac{1}{2\pi} \int_0^{2\pi} \left[\frac{1}{2} \left(\frac{\phi - \beta}{k} \omega + \gamma \right) \phi - \phi^3 + \frac{1}{2} k^2 \phi_{,\theta}^2 \right] d\theta \\ &= \frac{1}{2\pi} \int_0^{2\pi} \left[\frac{1}{2} c \phi^2 - \phi^3 + \frac{1}{2} k^2 \phi_{,\theta}^2 \right] d\theta + \frac{1}{2} (\gamma - c\beta) \beta, \end{aligned}$$

which must be minimized among 2π -periodic functions $\phi(\theta)$ satisfying the constraint (8.53). To get rid of constraint (8.53) we introduce the Lagrange multiplier and consider the following equivalent variational problem: find the extremal of the functional

$$\begin{aligned} & \frac{1}{2\pi} \int_0^{2\pi} \left[\frac{1}{2} k^2 \phi_{,\theta}^2 + \frac{1}{2} c \phi^2 - \phi^3 \right] d\theta + \frac{1}{2} (\gamma - c\beta) \beta - \lambda \left(\frac{1}{2\pi} \int_0^{2\pi} \phi d\theta - \beta \right) \\ &= \frac{1}{2\pi} \int_0^{2\pi} \left[\frac{1}{2} k^2 \phi_{,\theta}^2 - U(\phi, c, \lambda) \right] d\theta + \frac{1}{2} (\gamma - c\beta) \beta + \lambda \beta \end{aligned}$$

among λ and $\phi(\theta)$ satisfying the periodicity conditions

$$\phi(2\pi) = \phi(0), \quad \phi_{,\theta}(2\pi) = \phi_{,\theta}(0),$$

where the function of three arguments $U(\phi, c, \lambda)$ is given by

$$U(\phi, c, \lambda) = \phi^3 - \frac{1}{2}c\phi^2 + \lambda\phi.$$

This variational problem leads to Lagrange's equation of second order in terms of $\phi(\theta)$, which possesses an obvious first integral

$$\frac{1}{2}k^2\phi_{,\theta}^2 + U(\phi, c, \lambda) = h.$$

Using this formula and introducing an elliptic integral

$$W(c, \lambda, h) = \frac{1}{2\pi} \oint \sqrt{2h - 2U(\phi, c, \lambda)} d\phi = \frac{1}{2\pi} \oint \sqrt{2h - 2\lambda\phi + c\phi^2 - 2\phi^3} d\phi,$$

we find the average Lagrangian as the minimum of the above functional in the form

$$\bar{L}(\lambda, \beta, \gamma, h, k, \omega) = kW\left(\frac{\omega}{k}, \lambda, h\right) + \frac{1}{2}(\gamma - \frac{\omega}{k}\beta)\beta + \lambda\beta - h.$$

Then the variational-asymptotic analysis leads to the following average variational problem

$$\delta \iint \bar{L}(\lambda, \chi_{,x}, -\chi_{,t}, h, \theta_{,x}, -\theta_{,t}) dxdt = 0.$$

The Euler-Lagrange's equations for λ and χ read

$$\beta = -kW_{,\lambda}, \quad \frac{1}{2}\beta_{,t} - (\lambda + \frac{1}{2}\gamma - c\beta)_{,x} = 0.$$

From the last equation and from the consistency condition $\beta_{,t} + \gamma_{,x} = 0$ it follows that γ can be taken as $\gamma = c\beta - \lambda$. Thus, $\beta = -kW_{,\lambda}$, $\gamma = -ckW_{,\lambda} - \lambda$, and the consistency condition becomes

$$(kW_{,\lambda})_{,t} + (ckW_{,\lambda} + \lambda)_{,x} = 0. \quad (8.54)$$

For h and θ we have

$$kW_{,h} = 1, \quad (\bar{L}_{,\omega})_{,t} - (\bar{L}_{,k})_{,x} = 0.$$

Multiplying the last equation by k and using the chain rule of differentiation together with the consistency condition $k_{,t} + \omega_{,x} = 0$, we obtain

$$(k\bar{L}_{,\omega})_{,t} - (k\bar{L}_{,k})_{,x} + \bar{L}_{,\omega}\omega_{,x} + \bar{L}_{,k}k_{,x} = 0. \quad (8.55)$$

On the other hand, differentiation of the average Lagrangian \bar{L} with respect to x gives

$$\begin{aligned} \bar{L}_{,x} &= \bar{L}_{,k}k_{,x} + \bar{L}_{,\omega}\omega_{,x} + \bar{L}_{,\beta}\beta_{,x} + \bar{L}_{,\gamma}\gamma_{,x} \\ &= \bar{L}_{,k}k_{,x} + \bar{L}_{,\omega}\omega_{,x} + (\beta\bar{L}_{,\beta})_{,x} - \beta(\bar{L}_{,\beta})_{,x} - (\beta\bar{L}_{,\gamma})_{,t} + \beta(\bar{L}_{,\gamma})_{,t}, \end{aligned}$$

which implies

$$\bar{L}_{,\omega}\omega_{,x} + \bar{L}_{,k}k_{,x} = \bar{L}_{,x} - (\beta\bar{L}_{,\beta})_{,x} + (\beta\bar{L}_{,\gamma})_{,t} + \beta[(\bar{L}_{,\gamma})_{,t} - (\bar{L}_{,\beta})_{,x}].$$

The last term vanishes due to the Lagrange's equation for χ yielding

$$\bar{L}_{,\omega}\omega_{,x} + \bar{L}_{,k}k_{,x} = \bar{L}_{,x} - (\beta\bar{L}_{,\beta})_{,x} + (\beta\bar{L}_{,\gamma})_{,t}. \quad (8.56)$$

Substituting (8.56) into (8.55), we obtain the so-called wave momentum equation

$$(k\bar{L}_{,\omega} + \beta\bar{L}_{,\gamma})_{,t} + (\bar{L} - k\bar{L}_{,k} - \beta\bar{L}_{,\beta})_{,x} = 0,$$

which can replace the Lagrange's equation for θ . In our case, this equation becomes

$$(kW_{,c})_{,t} + (ckW_{,c} - h)_{,x} = 0. \quad (8.57)$$

Again, the consistency condition

$$k_{,t} + (ck)_{,x} = 0 \quad (8.58)$$

has to be included. Equations (8.54), (8.57), and (8.58) may be viewed as three equations for h , λ , and c , with k given by the dispersion relation $k = 1/W_{,h}$. A more symmetric equivalent form of this system is

$$\frac{D}{Dt}(W_{,h}) = W_{,h}c_{,x}, \quad \frac{D}{Dt}(W_{,\lambda}) = -W_{,h}\lambda_{,x}, \quad \frac{D}{Dt}(W_{,c}) = W_{,h}h_{,x}, \quad (8.59)$$

where

$$\frac{D}{Dt} = \frac{\partial}{\partial t} + c\frac{\partial}{\partial x}.$$

In terms of these unknown functions the wave number, the frequency, and the mean value of u , $\bar{u} = \beta$, are given by

$$k = \frac{1}{W_{,h}}, \quad \omega = \frac{c}{W_{,h}}, \quad \beta = -\frac{W_{,\lambda}}{W_{,h}}.$$

The amplitude is obtained by relating the zeros of the cubic polynomial in W to the coefficients h , λ , and c .

The Characteristic Equations. It turns out that the system (8.59) is hyperbolic and can be written in the characteristic form. If the zeros b_1, b_2, b_3 of the cubic equation

$$\phi^3 - \frac{1}{2}c\phi^2 + \lambda\phi - h = 0 \quad (8.60)$$

are used as new unknown functions instead of h, λ, c , Whitham's equations may be put in a simple characteristic form as

$$\frac{D}{Dt}r_j + V_j r_{j,x} = 0, \quad j = 1, 2, 3, \quad (\text{no sum!})$$

where $r_1 = b_2 + b_3$, $V_1 = W_{,h}/(W_{,h})_{,b_1}$, together with similar equations for r_2 and r_3 in cyclic permutation. In the following we sketch a brief proof for the first of these equations. Let us factorize the cubic polynomial (8.60) as

$$\phi^3 - \frac{1}{2}c\phi^2 + \lambda\phi - h = (\phi - b_1)(\phi - b_2)(\phi - b_3).$$

According to this identity the unknowns c , λ , h are related to the zeros b_1 , b_2 , b_3 by

$$c = 2(b_1 + b_2 + b_3), \quad \lambda = b_1b_2 + b_1b_3 + b_2b_3, \quad h = b_1b_2b_3.$$

Differentiating these relations with respect to x , we rewrite Whitham's equations (8.59) in terms of new unknown functions b_j in the form

$$\begin{aligned} (W_{,h})_{,b_1} \frac{Db_1}{Dt} + (W_{,h})_{,b_2} \frac{Db_2}{Dt} + (W_{,h})_{,b_3} \frac{Db_3}{Dt} &= 2W_{,h}(b_{1,x} + b_{2,x} + b_{3,x}), \\ (W_{,\lambda})_{,b_1} \frac{Db_1}{Dt} + (W_{,\lambda})_{,b_2} \frac{Db_2}{Dt} + (W_{,\lambda})_{,b_3} \frac{Db_3}{Dt} &= -W_{,h}[(b_2 + b_3)b_{1,x} \\ &\quad + (b_1 + b_3)b_{2,x} + (b_1 + b_2)b_{3,x}], \\ (W_{,c})_{,b_1} \frac{Db_1}{Dt} + (W_{,c})_{,b_2} \frac{Db_2}{Dt} + (W_{,c})_{,b_3} \frac{Db_3}{Dt} &= W_{,h}(b_2b_3b_{1,x} + b_1b_3b_{2,x} + b_1b_2b_{3,x}). \end{aligned} \quad (8.61)$$

We introduce

$$f(\phi) = 2h - 2\lambda\phi + c\phi^2 - 2\phi^3 = -2(\phi - b_1)(\phi - b_2)(\phi - b_3),$$

and denote the elliptic integral as follows

$$W(c, \lambda, h) = \frac{1}{2\pi} \oint \sqrt{2h - 2\lambda\phi + c\phi^2 - 2\phi^3} d\phi = \frac{1}{2\pi} \oint \sqrt{f(\phi)} d\phi.$$

With this notation at hand we compute $W_{,h}$, $W_{,\lambda}$, $W_{,c}$

$$W_{,h} = \frac{1}{2\pi} \oint \frac{d\phi}{\sqrt{f(\phi)}}, \quad W_{,\lambda} = -\frac{1}{2\pi} \oint \frac{\phi d\phi}{\sqrt{f(\phi)}}, \quad W_{,c} = \frac{1}{2\pi} \oint \frac{\phi^2 d\phi}{2\sqrt{f(\phi)}}.$$

Next, differentiating these formulas with respect to b_1 , we obtain

$$\begin{aligned} (W_{,h})_{,b_1} &= \frac{1}{4\pi} \oint \frac{1}{(\phi - b_1)\sqrt{f(\phi)}} d\phi, \\ (W_{,\lambda})_{,b_1} &= -\frac{1}{4\pi} \oint \frac{\phi}{(\phi - b_1)\sqrt{f(\phi)}} d\phi, \\ (W_{,c})_{,b_1} &= \frac{1}{4\pi} \oint \frac{\phi^2}{2(\phi - b_1)\sqrt{f(\phi)}} d\phi. \end{aligned}$$

Similar formulas hold true for the derivatives with respect to b_2 and b_3 . Now the trick comes to play at this step. We multiply the first equation of (8.61) by p , the second by q , and the third by r , add them, and choose p, q, r in such a way that the coefficient of $b_{1,x}$ on the right-hand side vanishes, while those of $b_{2,x}$ and $b_{3,x}$ are equal. This leads to the two following conditions

$$\begin{aligned} 2p - q(b_2 + b_3) + rb_2b_3 &= 0, \\ 2p - q(b_1 + b_3) + rb_1b_3 &= 2p - q(b_1 + b_2) + rb_1b_2. \end{aligned}$$

The solution of the above system reads

$$q = rb_1, \quad p = \frac{r}{2}(b_1b_2 + b_1b_3 - b_2b_3),$$

in which r can be chosen arbitrarily. Let us choose $r = 2$ for convenience and obtain the explicit expressions for q and p

$$r = 2, \quad q = 2b_1, \quad p = b_1b_2 + b_1b_3 - b_2b_3.$$

With this choice, the right-hand side of the equation resulted from these operations takes the form

$$\begin{aligned} \text{RHS} &= [2(b_1b_2 + b_1b_3 - b_2b_3) - 2b_1(b_1 + b_3) + 2b_1b_3]W_{,h}(b_2 + b_3)_{,x} \\ &= -2(b_1 - b_2)(b_1 - b_3)W_{,h}(b_2 + b_3)_{,x}. \end{aligned} \quad (8.62)$$

Let us turn now to the left-hand side and denote by K_1, K_2 , and K_3 the coefficients of $Db_1/Dt, Db_2/Dt$, and Db_3/Dt , respectively. Then we have

$$\begin{aligned} K_1 &= p(W_{,h})_{,b_1} + q(W_{,\lambda})_{,b_1} + r(W_{,c})_{,b_1} \\ &= \frac{1}{4\pi} \oint \frac{b_1b_2 + b_1b_3 - b_2b_3 - 2b_1\phi + \phi^2}{(\phi - b_1)\sqrt{f(\phi)}} d\phi, \\ K_2 &= p(W_{,h})_{,b_2} + q(W_{,\lambda})_{,b_2} + r(W_{,c})_{,b_2} \\ &= \frac{1}{4\pi} \oint \frac{b_1b_2 + b_1b_3 - b_2b_3 - 2b_1\phi + \phi^2}{(\phi - b_2)\sqrt{f(\phi)}} d\phi, \\ K_3 &= p(W_{,h})_{,b_3} + q(W_{,\lambda})_{,b_3} + r(W_{,c})_{,b_3} \\ &= \frac{1}{4\pi} \oint \frac{b_1b_2 + b_1b_3 - b_2b_3 - 2b_1\phi + \phi^2}{(\phi - b_3)\sqrt{f(\phi)}} d\phi. \end{aligned}$$

One can prove the following identities (see exercise 8.11)

$$K_1 = 0, \quad K_2 = K_3. \quad (8.63)$$

Furthermore, we can rewrite the coefficients K_2 and K_3 as

$$K_2 = -\frac{b_1 - b_2}{2\pi} \oint \frac{\phi - b_3}{(\phi - b_2)\sqrt{f(\phi)}} d\phi + \frac{1}{4\pi} \oint \frac{\phi^2 - 2b_2\phi + b_1b_2 + b_2b_3 - b_1b_3}{(\phi - b_2)\sqrt{f(\phi)}} d\phi,$$

$$K_3 = -\frac{b_1 - b_3}{2\pi} \oint \frac{\phi - b_2}{(\phi - b_3)\sqrt{f(\phi)}} d\phi + \frac{1}{4\pi} \oint \frac{\phi^2 - 2b_3\phi + b_1b_3 + b_2b_3 - b_1b_2}{(\phi - b_3)\sqrt{f(\phi)}} d\phi.$$

The last terms in K_2 and K_3 vanish because their integrands are again full differentials. Thus,

$$K_2 = -(b_1 - b_2)W_{,h} - 2(b_1 - b_2)(b_2 - b_3)(W_{,h})_{,b_2},$$

$$K_3 = -(b_1 - b_3)W_{,h} - 2(b_1 - b_3)(b_3 - b_2)(W_{,h})_{,b_3}.$$

Equality $K_2 = K_3$ gives

$$W_{,h} = 2[(b_1 - b_2)(W_{,h})_{,b_2} + (b_1 - b_3)(W_{,h})_{,b_3}],$$

which implies

$$K_2 = K_3 = -2(b_1 - b_2)(b_1 - b_3)[(W_{,h})_{,b_2} + (W_{,h})_{,b_3}].$$

Due to the identity

$$(W_{,h})_{,b_1} + (W_{,h})_{,b_2} + (W_{,h})_{,b_3} = \frac{1}{4\pi} \oint \frac{f'(\phi)}{f^{3/2}(\phi)} d\phi = 0,$$

we can write the last formula in the form

$$K_2 = K_3 = 2(b_1 - b_2)(b_1 - b_3)(W_{,h})_{,b_1}. \tag{8.64}$$

With (8.62) and (8.64) we get one of the Whitham's equations in the characteristic form

$$\frac{D}{Dt}(b_2 + b_3) + \frac{W_{,h}}{(W_{,h})_{,b_1}}(b_2 + b_3)_{,x} = 0,$$

which shows that $b_2 + b_3$ is the Riemann's invariant. The other two equations for r_2 and r_3 in cyclic permutations can be established in the same manner.

Alternative Representation of Whitham's Equations. Whitham's equations involve three unknown functions, namely c , λ , and h . In order to find the amplitude modulation in particular cases such as wave of small up to moderate amplitudes or trains of solitons one have to relate them to the amplitude $a = b_1 - b_2$. Then, using Whitham's equation in the characteristic form, different types of solution can be found. Here and below we consider an alternative but equivalent version of system of equations which directly involves the amplitude. For this purpose let us define the amplitude in a slightly different way

$$a = \max \phi.$$

Note that the amplitude defined in this way is nothing else but b_1 . Using this definition, we rewrite the average Lagrangian as follows

$$\bar{L} = \frac{k\sqrt{2}}{\pi} \int_{b_2}^a \sqrt{U(a, c, \lambda) - U(\phi, c, \lambda)} d\phi - U(a, c, \lambda) + \lambda\beta + \frac{1}{2}(\gamma - c\beta)\beta, \quad (8.65)$$

where the energy level h has been replaced by $U(a, c, \lambda)$, namely $h = U(a, c, \lambda)$. Observe that the integrand in the above integral vanishes at three zeros a, b_2, b_3 due to

$$U(a, c, \lambda) - U(\phi, c, \lambda) = (a - \phi)(\phi - b_2)(\phi - b_3).$$

This circumstance will be used later when one differentiates the average Lagrangian. The Euler-Lagrange's equations associated with this average Lagrangian read

$$\begin{aligned} \frac{\partial \bar{L}}{\partial a} = 0, \quad \frac{\partial}{\partial t} \frac{\partial \bar{L}}{\partial \omega} - \frac{\partial}{\partial x} \frac{\partial \bar{L}}{\partial k} = 0, \\ \frac{\partial \bar{L}}{\partial \lambda} = 0, \quad \frac{\partial}{\partial t} \frac{\partial \bar{L}}{\partial \gamma} - \frac{\partial}{\partial x} \frac{\partial \bar{L}}{\partial \beta} = 0. \end{aligned} \quad (8.66)$$

The first equation is nothing else but the dispersion relation, whereas the third equation is equivalent to the constraint (8.53). To express these equations in terms of $a, c,$ and λ let us compute the derivative of \bar{L} from (8.65) with respect to a and λ

$$\begin{aligned} \frac{\partial \bar{L}}{\partial a} &= \frac{\partial U}{\partial a}(a, c, \lambda) \left[\frac{k\sqrt{2}}{2\pi} \int_{b_2}^a \frac{d\phi}{\sqrt{U(a, c, \lambda) - U(\phi, c, \lambda)}} - 1 \right], \\ \frac{\partial \bar{L}}{\partial \lambda} &= \frac{\partial U}{\partial \lambda}(a, c, \lambda) \left[\frac{k\sqrt{2}}{2\pi} \int_{b_2}^a \frac{d\phi}{\sqrt{U(a, c, \lambda) - U(\phi, c, \lambda)}} - 1 \right] \\ &\quad - \frac{k\sqrt{2}}{2\pi} \int_{b_2}^a \frac{\phi d\phi}{\sqrt{U(a, c, \lambda) - U(\phi, c, \lambda)}} + \beta. \end{aligned}$$

Thus, the dispersion relation and the constraint associated with λ follow at once

$$\frac{k\sqrt{2}}{2\pi} \int_{b_2}^a \frac{d\phi}{\sqrt{U(a, c, \lambda) - U(\phi, c, \lambda)}} - 1 = 0, \quad (8.67)$$

$$\frac{k\sqrt{2}}{2\pi} \int_{b_2}^a \frac{\phi d\phi}{\sqrt{U(a, c, \lambda) - U(\phi, c, \lambda)}} - \beta = 0. \quad (8.68)$$

Let us turn now to the equation of amplitude modulation. First, we compute the derivative of \bar{L} with respect to ω

$$\begin{aligned} \frac{\partial \bar{L}}{\partial \omega} &= \frac{\partial U}{\partial c}(a, c, \lambda) \frac{\partial c}{\partial \omega} \left[\frac{k\sqrt{2}}{2\pi} \int_{b_2}^a \frac{d\phi}{\sqrt{U(a, c, \lambda) - U(\phi, c, \lambda)}} - 1 \right] \\ &+ \frac{\sqrt{2}}{4\pi} F(a, c, \lambda) - \frac{\beta^2}{2k} = \frac{\sqrt{2}}{4\pi} F(a, c, \lambda) - \frac{\beta^2}{2k}, \end{aligned}$$

where

$$F(a, c, \lambda) = \int_{b_2}^a \frac{\phi^2 d\phi}{\sqrt{U(a, c, \lambda) - U(\phi, c, \lambda)}}.$$

Differentiation of \bar{L} with respect to k gives

$$\begin{aligned} \frac{\partial \bar{L}}{\partial k} &= \frac{\sqrt{2}}{\pi} \int_{b_2}^a \sqrt{U(a, c, \lambda) - U(\phi, c, \lambda)} d\phi \\ &+ \frac{\partial U}{\partial c}(a, c, \lambda) \frac{\partial c}{\partial k} \left[\frac{k\sqrt{2}}{2\pi} \int_{b_2}^a \frac{d\phi}{\sqrt{U(a, c, \lambda) - U(\phi, c, \lambda)}} - 1 \right] \\ &+ \frac{\partial c}{\partial k} \left[\frac{k\sqrt{2}}{4\pi} \int_{b_2}^a \frac{\phi^2 d\phi}{\sqrt{U(a, c, \lambda) - U(\phi, c, \lambda)}} - \frac{1}{2} \beta^2 \right] \\ &= \frac{\sqrt{2}}{\pi} \int_{b_2}^a \sqrt{U(a, c, \lambda) - U(\phi, c, \lambda)} d\phi - c \frac{\partial \bar{L}}{\partial \omega}. \end{aligned}$$

Plugging these derivatives into (8.66)₂, we obtain the Euler-Lagrange's equation for θ

$$\begin{aligned} &\frac{\sqrt{2}}{4\pi} \left[\frac{\partial F}{\partial a}(a, c, \lambda) + \frac{\partial F}{\partial c}(c, c, \lambda) + \frac{\partial F}{\partial \lambda}(\lambda, c, \lambda) \right] + \frac{\sqrt{2}}{4\pi} F(a, c, \lambda) c_{,x} \\ &- \frac{1}{2} \left[\left(\frac{\beta^2}{k} \right)_{,t} + \left(c \frac{\beta^2}{k} \right)_{,x} \right] - \frac{\sqrt{2}}{\pi} \frac{\partial}{\partial x} \int_{b_2}^a \sqrt{U(a, c, \lambda) - U(\phi, c, \lambda)} d\phi = 0. \end{aligned}$$

Further, using the dispersion relation (8.67) and constraint (8.68), we compute the derivative

$$\begin{aligned} J &= \frac{\partial}{\partial x} \int_{b_2}^a \sqrt{U(a, c, \lambda) - U(\phi, c, \lambda)} d\phi \\ &= \frac{\pi}{k\sqrt{2}} \frac{\partial U}{\partial a}(a, c, \lambda) a_{,x} - \frac{1}{2} \frac{\pi}{k\sqrt{2}} a^2 c_{,x} + \frac{\pi}{k\sqrt{2}} a \lambda_{,x} - \frac{\pi}{k\sqrt{2}} \beta \lambda_{,x} + \frac{1}{4} F(a, c, \lambda) c_{,x}. \end{aligned}$$

Finally, substituting this expression into the above equation and dividing the latter by $\sqrt{2}/4\pi$, we obtain the equation of amplitude modulation in terms of a , c and λ

$$\begin{aligned} &\frac{\partial F}{\partial a}(a, c, \lambda) + \frac{\partial F}{\partial c}(c, c, \lambda) + \frac{\partial F}{\partial \lambda}(\lambda, c, \lambda) \\ &+ \frac{\pi\sqrt{2}}{k} \left\{ a^2 c_{,x} - 2\partial_a U(a, c, \lambda) a_{,x} + 2(\beta - a) \lambda_{,x} - k \left[\left(\frac{\beta^2}{k} \right)_{,t} + \left(c \frac{\beta^2}{k} \right)_{,x} \right] \right\} = 0. \end{aligned} \tag{8.69}$$

As indicated in the previous paragraph, the equation for χ will be automatically satisfied if the parameters are chosen such that

$$\gamma = c\beta - \lambda. \quad (8.70)$$

The four equations (8.67)-(8.70) constitute a system of differential equations which is equivalent to (8.59) plus the dispersion relation $kW_h = 1$.

Trains of Solitons. In the limit $\lambda \rightarrow 0$ and $h \rightarrow 0$, the wave packet becomes a train of solitary waves. For the wave packet consisting of n solitons we know that the solitons cease to interact at large time in such a way that each of them propagates with a constant velocity along the line $x/t = \text{const}$. Based on this observation we look for the solution $a = a(x, t)$ of (8.69) using the following Ansatz for θ and χ

$$\theta(x, t) = q(\xi(x, t)), \quad \chi(x, t) = p(\xi(x, t)), \quad \xi(x, t) = x/t.$$

Differentiating $\theta(x, t)$ and $\chi(x, t)$ in accordance with these Ansatz, we find k , ω , c , β , and γ in the form

$$k = \frac{1}{t}q'(\xi), \quad \omega = \frac{x}{t^2}q'(\xi), \quad c = \frac{x}{t},$$

$$\beta = \frac{1}{t}p'(\xi), \quad \gamma = \frac{x}{t^2}p'(\xi).$$

It is easy to see that β and γ from the last equations satisfy (8.70), provided $\lambda = 0$. Besides, the following equation

$$\left(\frac{\beta^2}{k}\right)_t + \left(c\frac{\beta^2}{k}\right)_x = 0$$

is fulfilled identically. Furthermore, if the amplitude is searched among functions of the form

$$a(x, t) = g(\xi(x, t)),$$

the term $\frac{\partial F}{\partial a}(a_t + ca_{,x})$ vanishes, so (8.69) reduces to

$$g(\xi)^2 - 2\partial_a U(g(\xi), \xi, 0)g'(\xi) = 0,$$

where $\partial_a U(a, c, \lambda) = 3a^2 - ca + \lambda$. The last equation can also be rewritten as

$$g(\xi)^2 - (6g(\xi)^2 - 2\xi g(\xi))g'(\xi) = 0,$$

which is equivalent to

$$g(\xi) - (6g(\xi) - 2\xi)g'(\xi) = 0. \quad (8.71)$$

General solution of (8.71) contains one constant of integration that should be determined from the dispersion relation. In the following we shall guess a particular

solution of (8.71) and prove its validity by verifying the fulfillment of dispersion relation at large time. Looking at this equation, we see that one of its possible solutions is the linear function

$$g(\xi) = C_1 \xi + C_2.$$

Substituting this guess into (8.71) and equating the coefficient of first power of ξ and the free one to zero, we find

$$C_1 = 1/2, \quad C_2 = 0.$$

Thus, a simple particular solution of (8.69) reads

$$a(x, t) = \frac{x}{2t}. \quad (8.72)$$

To see the fulfillment of the dispersion relation at large time we rewrite (8.67) in an equivalent form

$$k = \frac{\pi \sqrt{(a-b_2)/2}}{mK(m)}, \quad m = \sqrt{\frac{a-b_2}{a-b_3}},$$

where $K(m)$ is the complete elliptic integral. In the limit $\lambda \rightarrow 0$, $h \rightarrow 0$, the roots b_2 and b_3 go to 0, so $m \rightarrow 1$. Provided the derivative $q'(x/t)$ is finite, the left- and right-hand sides of the dispersion relation tend to 0 as $t \rightarrow \infty$, so the dispersion relation is satisfied asymptotically at large time.

Recalling that a soliton of amplitude a moves with the velocity $2a$, one can easily recognize that (8.72) represents a large-time asymptotic envelope of a sequence of solitons each retaining a constant amplitude and moving on the path $x = 2at$ as shown in Fig. 8.11. Another way of obtaining this amplitude modulation of soliton solution is to derive the system of equations

$$\bar{k}_{,t} + (2a\bar{k})_{,x} = 0, \quad a_{,t} + 2aa_{,x} = 0, \quad \bar{k} = \frac{k}{2\pi} \quad (8.73)$$

directly from the conservation laws of the KdV equation and integrate it. Note that, due to the nonlinearity and hyperbolicity of the system (8.73), the shock wave will develop sooner or later which violates the amplitude modulation. However, in this case equations (8.73) can be used to justify the jump conditions at the shock waves (see exercise 8.12).

Thus, we are now at the end of these lectures. Before closing, let us summarize shortly. Looking back, one sees that we have learned a lot of things. Among them, we would put on the first place Hamilton's variational principle of least action and its generalizations for the derivation of the equations of motion. We have studied also various methods of solving these equations and finding laws of behavior of the solutions. Some of the numerical methods, in particular finite element method, were not touched at all. But fortunately there are other excellent courses where one can learn those methods (see, for instance, [41, 55]). One thing is for sure: with numerical methods *alone* one can hardly establish any *behavioral law* for the solutions.

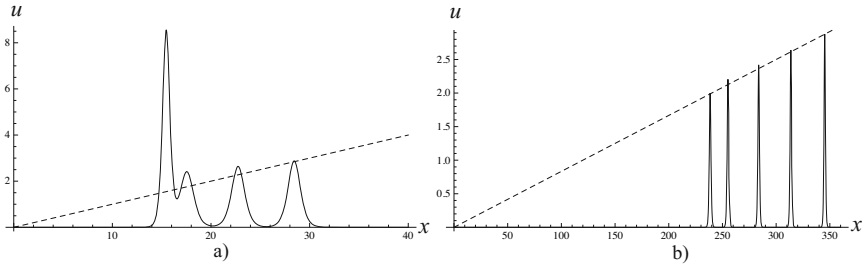

Fig. 8.11 A train of solitons (bold line) and the amplitude modulation (dashed line): a) at small time, b) at large time

To establish such laws, which are often quite useful in engineering applications, analytical skills have to be trained and cultivated. For those problems containing small parameters, the variational-asymptotic method turns out quite effective, and it is hoped that this course has helped students a little bit in mastering it. Last but not least, one should not forget about the exercises. Just remember “Übung macht den Meister” (practice makes perfect), as Germans say.

8.6 Exercises

EXERCISE 8.1. Use the identities for the Jacobian elliptic functions sn , cn , and dn given in Section 5.1 to check that $\varphi(\xi) = a \text{cn}^2(\sqrt{b/2}\xi, a/b)$, with $\xi = x - ct$, is the periodic solution of the KdV equation (in this case $b_1 = a, b_2 = 0, b_3 = a - b$).

Solution. In the special case

$$b_1 = a, \quad b_2 = 0, \quad b_3 = a - b,$$

where a and $b > a$ are two real and positive numbers, the first integral for the periodic solution of the KdV equation reduces to

$$\varphi'^2 = 2(a - \varphi)\varphi(\varphi + b - a).$$

Let us check that

$$\varphi(\xi) = a \text{cn}^2(\sqrt{b/2}\xi, a/b)$$

satisfies this equation. Differentiating φ with respect to ξ and using the formulas for the Jacobian elliptic functions sn , cn , and dn given in Section 5.1, we get

$$\varphi' = -2a\sqrt{b/2}\text{cn}(\sqrt{b/2}\xi, a/b)\text{sn}(\sqrt{b/2}\xi, a/b)\text{dn}(\sqrt{b/2}\xi, a/b).$$

Squaring both sides of this formula and using the identities $\text{sn}^2 = 1 - \text{cn}^2$ and $\text{dn}^2 = 1 - m + m\text{cn}^2$, with $m = a/b$, one can easily show that $\varphi(\xi) = a \text{cn}^2(\sqrt{b/2}\xi, a/b)$ satisfies the above equation.

EXERCISE 8.2. Show that

$$u(x, t) = 4 \arctan e^{\gamma(x-ct)},$$

with $\gamma = 1/\sqrt{1-c^2}$ is the soliton solution of the Sine-Gordon equation.

Solution. Consider the Sine-Gordon equation

$$u_{,tt} - u_{,xx} + \sin u = 0.$$

We look for the soliton solution in the form

$$u(x, t) = \varphi(x - ct),$$

with c being a constant. Substitution in the above equation gives

$$(c^2 - 1)\varphi'' + \sin \varphi = 0,$$

where prime denotes the derivative with respect to $\xi = x - ct$. The last equation can be presented in the form

$$m\varphi'' - U'(\varphi) = 0,$$

with

$$m = 1 - c^2, \quad U(\varphi) = 1 - \cos \varphi.$$

This resembles the equation of motion of mass-spring oscillator with a mass $m = 1 - c^2$ and a nonlinear restoring force derivable from the potential energy $-U(\varphi)$. The first integral is

$$\frac{1}{2}m\varphi'^2 - U(\varphi) = h.$$

If φ and its first derivative tend to zero as $\xi \rightarrow \pm\infty$, then $h = 0$. In this case

$$\varphi' = \frac{2}{\sqrt{m}} \sin(\varphi/2).$$

Integrating this equation by separating the variables ξ and φ , we obtain

$$\sqrt{m} \ln[\tan(\varphi/4)] = \xi, \tag{8.74}$$

and, thus,

$$u(x, t) = \varphi(\xi) = 4 \arctan e^{\gamma(x-ct)}.$$

EXERCISE 8.3. Use the conservation law of the KdV equation

$$u_{,t} + (3u^2 + u_{,xx})_{,x} = 0$$

to show that

$$I_{-1} = \int_{-\infty}^{\infty} u dx$$

is the first integral. Show that the conservation laws of the KdV equation for I_0 and I_1 are

$$(u^2)_{,t} + (4u^3 + 2uu_{,xx} - u_{,x}^2)_{,x} = 0,$$

$$(u^3 - \frac{1}{2}u_{,xx}^2)_{,t} + (\frac{9}{2}u^4 + 3u^2u_{,xx} - 6uu_{,x}^2 - u_{,x}u_{,xxx} + \frac{1}{2}u_{,xx}^2)_{,x} = 0.$$

Solution. It is easy to see that the equation

$$u_{,t} + (3u^2 + u_{,xx})_{,x} = 0$$

follows at once from the KdV equation. Integrating this equation over x from $-\infty$ to ∞ and taking into account the behavior of the solution at infinity, we obtain

$$\frac{d}{dt} \int_{-\infty}^{\infty} u dx = 0,$$

so I_{-1} is conserved. Differentiating the second equation, we have

$$2uu_{,t} + 12u^2u_{,x} + 2u_{,x}u_{,xx} + 2uu_{,xxx} - 2u_{,x}u_{,xx} = 0,$$

and it is again the consequence of the KdV equation. Integrating this conservation law over x from $-\infty$ to ∞ , we can establish that I_0 is conserved. To show that the third conservation law also follows from the KdV equation, we differentiate the expressions in the brackets to obtain

$$3u^2u_{,t} - \underline{u_{,x}u_{,xt}} + 18u^3u_{,x} + \underline{6uu_{,x}u_{,xx}} + 3u^2u_{,xxx} - \underline{6u_{,x}^3} - \underline{12uu_{,x}u_{,xx}} - u_{,xx}u_{,xxx} - \underline{u_{,x}u_{,xxx}} + u_{,xx}u_{,xxx} = 0.$$

The underlined terms represent the product of $u_{,x}$ with the derivative of the KdV equation with respect to x , taken with minus sign, while the remaining terms give the product of $3u^2$ with the KdV equation. So, the third conservation law is also the consequence of the KdV equation, and hence, I_1 is conserved.

EXERCISE 8.4. With the Lax's pair

$$L\psi = \psi_{,xx} + u(x,t)\psi, \quad A\psi = (\gamma + u_{,x})\psi - (4\lambda + 2u)\psi_{,x},$$

show that the Lax equation $L_{,t} + [L, A] = 0$ (which expresses the compatibility condition between $L\psi = \lambda\psi$ and $\psi_{,t} = A\psi$) is satisfied if and only if the KdV equation is fulfilled.

Solution. As shown in Section 8.2, the Lax equation is fulfilled if and only if $\lambda_{,t} = 0$. But if $\lambda_{,t} = 0$, then the differentiation of the equation $\psi_{,xx} + u\psi = \lambda\psi$ with respect to t yields

$$\psi_{,xxt} + u\psi_{,t} + u_{,t}\psi = \lambda\psi_{,t}.$$

Replacing $\psi_{,t}$ in this equation by $A\psi = (\gamma + u_{,x})\psi - (4\lambda + 2u)\psi_{,x}$, we obtain

$$\psi_{,xxt} = [(\lambda - u)(\gamma + u_{,x}) - u_{,t}] \psi - (\lambda - u)(4\lambda + 2u) \psi_{,x}.$$

On the other side, if we differentiate the evolution equation $\psi_t = A\psi$ with respect to x , then

$$\psi_{,tx} = (\gamma + u_{,x}) \psi_{,x} + u_{,xx} \psi - (4\lambda + 2u) \psi_{,xx} - 2u_{,x} \psi_{,x}.$$

Replacing $\psi_{,xx}$ by $(\lambda - u)\psi$, we obtain

$$\psi_{,tx} = (\gamma + u_{,x}) \psi_{,x} + u_{,xx} \psi - (4\lambda + 2u)(\lambda - u)\psi - 2u_{,x} \psi_{,x}.$$

Differentiating this again with respect to x with the use of the condition $\psi_{,xx} = (\lambda - u)\psi$ leads to

$$\psi_{,txx} = [(\gamma + u_{,x})(\lambda - u) + u_{,xxx} + 6uu_{,x}] \psi - (\lambda - u)(4\lambda + 2u) \psi_{,x}.$$

Thus, the two equations for $\psi_{,xxt}$ and $\psi_{,txx}$ are compatible ($\psi_{,xxt} = \psi_{,txx}$) if and only if u satisfies KdV equation.

EXERCISE 8.5. Consider two linear equations

$$\mathbf{v}_{,x} = \mathbf{X}\mathbf{v}, \quad \mathbf{v}_{,t} = \mathbf{T}\mathbf{v},$$

where \mathbf{v} is an n -dimensional vector and \mathbf{X} and \mathbf{T} are $n \times n$ matrices. Provided these equations are compatible, that is $\mathbf{v}_{,xt} = \mathbf{v}_{,tx}$, show that \mathbf{X} and \mathbf{T} satisfy

$$\mathbf{X}_{,t} - \mathbf{T}_{,x} + [\mathbf{X}, \mathbf{T}] = 0.$$

The pair \mathbf{X} and \mathbf{T} is similar to Lax's pair L and A , and the last equation may lead to various interesting equations of mathematical physics [1].

Solution. Let us differentiate the first equation with respect to t

$$\mathbf{v}_{,xt} = \mathbf{X}_{,t} \mathbf{v} + \mathbf{X} \mathbf{v}_{,t}.$$

Replacing $\mathbf{v}_{,t}$ by $\mathbf{T}\mathbf{v}$ in accordance with the second equation, we obtain

$$\mathbf{v}_{,xt} = (\mathbf{X}_{,t} + \mathbf{X}\mathbf{T})\mathbf{v}.$$

Analogously, the differentiation of the second equation with respect to x leads to

$$\mathbf{v}_{,tx} = (\mathbf{T}_{,x} + \mathbf{T}\mathbf{X})\mathbf{v}.$$

Thus, the above equations are compatible ($\mathbf{v}_{,xt} = \mathbf{v}_{,tx}$) if

$$\mathbf{X}_{,t} - \mathbf{T}_{,x} + [\mathbf{X}, \mathbf{T}] = 0.$$

EXERCISE 8.6. Consider the two-soliton solution

$$u(x, t) = 12 \frac{3 + 4 \cosh(2x - 8t) + \cosh(4x - 64t)}{[3 \cosh(x - 28t) + \cosh(3x - 36t)]^2}.$$

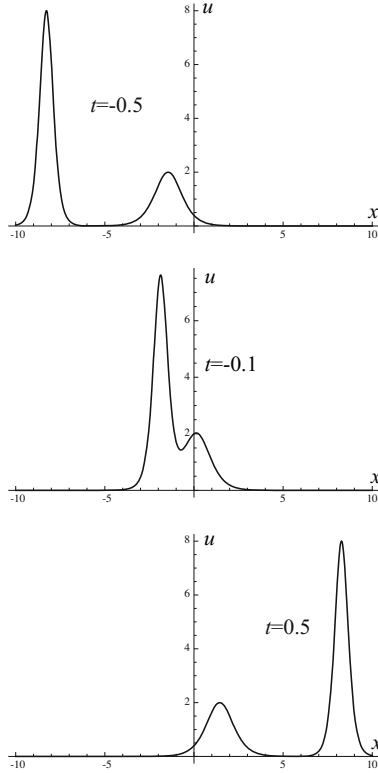

Fig. 8.12 Two solitons before, during, and after collision

Plot this function for the time instants before, during, and after the collision. Observe the behavior of the amplitudes and phases.

Solution. After opening a notebook in *Mathematica* we first define function $u(x, t)$ given above representing the two-soliton solution. Then, by typing the following command

```
Plot[u[x, -0.5], {x, -10, 10}, PlotRange -> All],
```

we plot this function at time instant $t = -0.5$. Doing the same for the time instants $t = -0.1$ and $t = 0.5$, we obtain the sequence of graphs representing two solitons moving to the right before, during, and after collision as shown in Fig. 8.12. One can observe that the solitons maintain their original shapes after the collision. The only change is the phase shift. The graph of this function in the (x, t) -plane was shown in Fig. 8.6.

EXERCISE 8.7. Find the average Lagrangian by solving the minimization problem

$$\bar{L} = \frac{1}{2\pi} \min_{\psi_1, \psi_2} \int_0^{2\pi} \left[\frac{1}{2} (\omega^2 - k^2) (\psi_{1,\theta}^2 + \psi_{2,\theta}^2) - U(\psi_1, \psi_2) \right] d\theta,$$

where

$$U(\psi_1, \psi_2) = \frac{1}{2}[\psi_1^2 + \frac{\alpha}{2}\psi_1^4 + \psi_2^2 + \frac{\alpha}{2}\psi_2^4 + \frac{\beta}{2}(\psi_2 - \psi_1)^4],$$

among 2π -periodic functions for which $\psi_2 = c\psi_1$.

Solution. Let $\psi_1 = \psi$. Substitute the relation $\psi_2 = c\psi$ (which describes the similar normal mode) into the above variational problem for the average Lagrangian, we reduce it to

$$\bar{L} = \frac{1}{2\pi} \min_{\max \psi = a} \int_0^{2\pi} [\frac{1}{2}(\omega^2 - k^2)(1 + c^2)\psi_{,\theta}^2 - U_1(\psi, c)] d\theta,$$

where

$$U_1(\psi, c) = \frac{1}{2}[(1 + c^2)\psi^2 + \frac{\alpha}{2}(1 + c^4)\psi^4 + \frac{\beta}{2}(1 - c)^4\psi^4].$$

Let prime denote the derivative with respect to θ . We use the first integral

$$\frac{1}{2}(\omega^2 - k^2)(1 + c^2)\psi'^2 + U_1(\psi, c) = U_1(a, c) = h$$

to express \bar{L} in the form

$$\bar{L} = \frac{1}{2\pi} \int_0^{2\pi} (\omega^2 - k^2)(1 + c^2)\psi'^2 d\theta - h.$$

Changing the variable $\theta \rightarrow \psi$, we obtain finally

$$\begin{aligned} \bar{L} &= \frac{1}{2\pi} (\omega^2 - k^2)(1 + c^2) \oint \psi' d\psi - h \\ &= \frac{1}{2\pi} \sqrt{2(\omega^2 - k^2)(1 + c^2)} \oint \sqrt{h - U_1(\psi, c)} d\psi - h. \end{aligned}$$

The contour integral in this formula denotes the integral over a complete oscillation of ψ from b , with $U_1(b, c) = U_1(a, c)$, up to a and back, so it is equal to twice the integral from b to a because the sign of the square root has to be changed appropriately in the two parts of the contour. This integral may also be interpreted as the contour integral around a cut from b to a in the complex ψ -plane, where ψ plays the role of the variable of integration.

EXERCISE 8.8. For the average Lagrange function

$$\bar{L} = \frac{\omega}{2\pi} \int_0^T p\dot{q} dt - h = \frac{\omega}{2\pi} \oint p(q, h, \lambda) dq - h$$

of an oscillator depending on the slowly changing parameter λ show that $\partial\bar{L}/\partial h = 0$ coincides with the amplitude-frequency equation.

Solution. We use the conservation of energy

$$\frac{1}{2m}p^2 + U(q, \lambda) = h$$

to express the impulse p in terms of q

$$p = \sqrt{2m} \sqrt{h - U(q, \lambda)}.$$

Substitute this into the formula for the average Lagrange function to obtain

$$\bar{L} = \frac{\omega}{2\pi} \sqrt{2m} \oint \sqrt{h - U(q, \lambda)} dq - h.$$

Let us differentiate this average Lagrange function with respect to h

$$\frac{\partial \bar{L}}{\partial h} = \frac{\omega}{2\pi} \sqrt{\frac{m}{2}} \oint \frac{dq}{\sqrt{h - U(q, \lambda)}} - 1.$$

Thus, the equation $\bar{L}_{,h} = 0$ is equivalent to

$$\oint \frac{dq}{\sqrt{2/m} \sqrt{h - U(q, \lambda)}} = \frac{2\pi}{\omega} = T.$$

The last equation is nothing else but the amplitude-frequency (or amplitude-period) relation; cf. (5.3).

EXERCISE 8.9. Show that the Sine-Gordon equation in cone coordinates takes the form

$$u_{,XT} = \sin u.$$

Develop the theory of slope modulation for this equation.

Solution. Using the cone-coordinates (8.48), we can establish, in our case, the following chain rule of differentiation

$$\begin{aligned} \frac{\partial}{\partial t} &= \frac{\partial}{\partial X} \frac{\partial X}{\partial t} + \frac{\partial}{\partial T} \frac{\partial T}{\partial t} = \frac{1}{2} \left(\frac{\partial}{\partial X} - \frac{\partial}{\partial T} \right), \\ \frac{\partial}{\partial x} &= \frac{\partial}{\partial X} \frac{\partial X}{\partial x} + \frac{\partial}{\partial T} \frac{\partial T}{\partial x} = \frac{1}{2} \left(\frac{\partial}{\partial X} + \frac{\partial}{\partial T} \right). \end{aligned}$$

Then the second derivatives follow

$$\frac{\partial^2}{\partial t^2} = \frac{1}{4} \left(\frac{\partial^2}{\partial X^2} - 2 \frac{\partial^2}{\partial X \partial T} + \frac{\partial^2}{\partial T^2} \right), \quad \frac{\partial^2}{\partial x^2} = \frac{1}{4} \left(\frac{\partial^2}{\partial X^2} + 2 \frac{\partial^2}{\partial X \partial T} + \frac{\partial^2}{\partial T^2} \right).$$

Thus, the left-hand side of Sine-Gordon can be replaced by

$$\left(\frac{\partial^2}{\partial t^2} - \frac{\partial^2}{\partial x^2} \right) u = - \frac{\partial^2}{\partial X \partial T} u,$$

and consequently, the Sine-Gordon equation in cone coordinates reads

$$-u_{,XT} + \sin u = 0 \quad \Rightarrow \quad u_{,XT} = \sin u.$$

The strip problem associated with this form of Sine-Gordon equation is stated as follows: find the extremal of the functional

$$\int_0^{2\pi} [\frac{1}{2}k\omega\psi_{,\theta}^2 - (1 - \cos\psi)]d\theta \tag{8.75}$$

among functions $\psi(\theta)$ satisfying

$$\psi(2\pi) = \psi(0) + 2\pi, \quad \psi_{,\theta}(2\pi) = \psi_{,\theta}(0). \tag{8.76}$$

The maximal slope of solution is defined as before: $p = \max|\psi_{,\theta}|$, with p being an arbitrary real and positive number. The construction of average Lagrangian as well as the associated functional has been discussed in Section 8.4. However, there are two modifications. Firstly, the first integral should read now

$$\frac{1}{2}m\psi_{,\theta}^2 + (1 - \cos\psi) = h, \quad m = k\omega.$$

The phase portrait is shown in Fig. 8.13, where it can be seen that the maximal slope is achieved at $\psi = 0$. This implies $mp^2/2 = h$. Secondly, the average Lagrangian need be slightly modified as follows

$$\bar{L}(p, k, \omega) = \frac{\sqrt{2m}}{2\pi} f(h) - h,$$

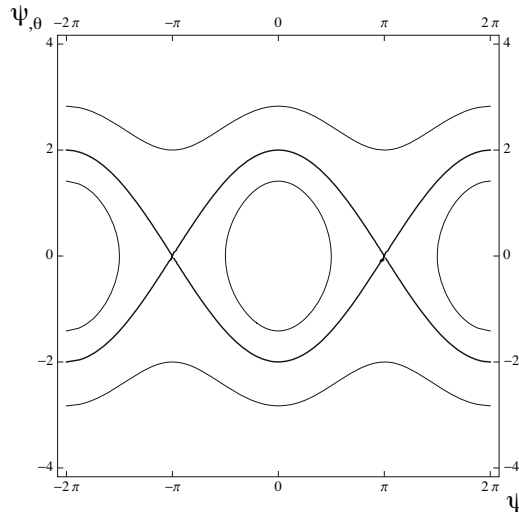

Fig. 8.13 Phase portrait associated with the strip problem with $m = 1$

where $f(h)$ is the function expressed in terms of the complete elliptic integral.

$$f(h) = \int_0^{2\pi} \sqrt{h - (1 - \cos\psi)} d\psi.$$

The latter is nothing else but the time required for a pendulum with mass $m = 2$ and unit length to complete its full circular motion in the gravitational field. Note that the average Lagrangian does not change its form compared to (8.38), so the dispersion relation remains unchanged in its form. To derive the equation of slope modulation let us compute the derivatives

$$\begin{aligned} \frac{\partial \bar{L}}{\partial k} &= \frac{\sqrt{2}}{2\pi} \frac{m_{,k}}{2\sqrt{m}} f(h) + \left(\frac{\sqrt{2m}}{2\pi} f'(h) - 1 \right) h_{,k} = \frac{\sqrt{2}}{4\pi} \frac{\omega}{\sqrt{k\omega}} f(h) = \frac{\sqrt{2}}{4\pi} \sqrt{c} f(h), \\ \frac{\partial \bar{L}}{\partial \omega} &= \frac{\sqrt{2}}{4\pi} \frac{m_{,\omega}}{2\sqrt{m}} f(h) + \left(\frac{\sqrt{2m}}{2\pi} f'(h) - 1 \right) h_{,\omega} = \frac{\sqrt{2}}{4\pi} \frac{k}{\sqrt{k\omega}} f(h) = \frac{\sqrt{2}}{4\pi} \frac{1}{\sqrt{c}} f(h), \end{aligned}$$

where $c = \omega/k$ and the dispersion relation (8.38) has been used in two steps. Next, we compute their derivatives with respect to X and T

$$\begin{aligned} \frac{\partial}{\partial X} \frac{\partial \bar{L}}{\partial k} &= \frac{\sqrt{2}}{4\pi} \left[\frac{c_{,X}}{2\sqrt{c}} f(h) + \frac{\sqrt{c}}{2} f'(h) (k_{,X} \omega + \omega_{,X} k) p^2 + \frac{\sqrt{c}}{2} f'(h) m(p^2)_{,X} \right], \\ \frac{\partial}{\partial T} \frac{\partial \bar{L}}{\partial \omega} &= \frac{\sqrt{2}}{4\pi} \left[-\frac{c_{,T}}{2c\sqrt{c}} f(h) + \frac{1}{2\sqrt{c}} f'(h) (k_{,T} \omega + \omega_{,T} k) p^2 + \frac{1}{2\sqrt{c}} f'(h) m(p^2)_{,T} \right]. \end{aligned}$$

Subtracting the second equation from the first one and dividing the result by the common factor $\sqrt{2}/4\pi$, we get, after some algebra,

$$\frac{f(h)}{2c\sqrt{c}} (c_{,T} + cc_{,X}) + \frac{f'(h)}{2\sqrt{c}} q(k_{,X} \frac{\omega^2}{k} + 2\omega_{,X} \omega - \omega_{,T} k) + \frac{f'(h)}{2\sqrt{c}} (\omega^2 q_{,X} - k \omega q_{,T}) = 0,$$

where the square of maximal slope is denoted by $q = p^2$.

We shall find only a particular solution to this equation using the Ansatz for the phase as before: $\theta(X, T) = g(\xi(X, T))$, $\xi(X, T) = X/T$. With this Ansatz the above equation reduces to

$$4[Tg'(\xi) + Xg''(\xi)]q(X, T) + Tg'(\xi)(Xq_{,X} - Tq_{,T}) = 0.$$

The last equation is the partial differential equation of first order which can be solved by the method of characteristics and whose solution is given by

$$q(X, T) = W(XT)^2 \frac{T^4}{g'(\xi(X, T))^2}, \quad \xi(X, T) = \frac{X}{T},$$

and thus,

$$p(X, T) = \sqrt{q(X, T)} = W(XT) \frac{T^2}{g'(\xi(X, T))}. \quad (8.77)$$

The unknown function $W(XT)$ should be determined from the expression for h in the limit $h \rightarrow 2$, which corresponds to the separatrix in the phase portrait

$$h = \frac{1}{2}mp^2 = \frac{1}{2}XT \times W(XT)^2 \Rightarrow W(XT) = \frac{2}{\sqrt{XT}}.$$

The final asymptotic formula for the slope reads

$$p(X, T) = \frac{2T\sqrt{T}}{\sqrt{|X|}g'(\xi(X, T))}.$$

EXERCISE 8.10. Use the analytical soliton solution for the Sine-Gordon equation given in cone coordinates by (8.49) to simulate the 5-soliton solution and compare it with the asymptotic formula $2\sqrt{T/|X|}$ at large time.

Solution. We use formula (8.49) representing the exact analytical solution of the Sine-Gordon equation. The *Mathematica* code which enables one to simulate this solution is reproduced below.

```
createDelta[eta_, c0_] := Block[{matrixC, gamma, num, m, k, n}, num = Length[eta];
  gamma = Table[Exp[-(eta[[k]] + eta[[n]]) X - (T/4) (1/eta[[k]] + 1/eta[[n]])], {k, num}, {n, num}];
  matrixC = Table[Null, {k, num}, {n, num}];
  For[k = 1, k <= num, k++,
    For[n = 1, n <= k, n++,
      matrixC[[k, n]] = Sum[c0[[m]] Sqrt[c0[[k]] c0[[n]]] (gamma[[k, m]] gamma[[m, n]] / (eta[[k]] + eta[[m]]) (eta[[m]] + eta[[n]])), {m, 1, num}];
      matrixC[[n, k]] = matrixC[[k, n]];
    ];
  Return[Det[IdentityMatrix[num] + matrixC]];
];
Delta = createDelta[Table[k, {k, 5}], Table[1, {5}]];
du = Sqrt[Simplify[4 (D[Delta, {X, 2}] Delta - (D[Delta, X])^2) / Delta^2]];
```

To explain this code let us first consider elements of matrix $C = AA^*$. Since the eigenvalues are purely imaginary, we have

$$\zeta_k - \zeta_n^* = i(\eta_k + \eta_n).$$

Therefore, function $c_k(T)$ and, consequently, its conjugate, turn out to be real functions

$$c_k(T) = c_{k0} \exp(-T/2\eta_k), \quad c_k(T)^* = c_k(T).$$

It is now easy to write the elements of matrix A and A^*

$$A_{kn} = -\frac{i\sqrt{c_{k0}c_{n0}}}{\eta_k + \eta_n} \gamma_{kn}(X, T), \quad A_{kn}^* = \frac{i\sqrt{c_{k0}c_{n0}}}{\eta_k + \eta_n} \gamma_{kn}(X, T),$$

$$\gamma_{kn}(X, T) = \exp\left[-(\eta_k + \eta_n)X - \frac{T}{4}\left(\frac{1}{\eta_k} + \frac{1}{\eta_n}\right)\right].$$

Thus,

$$C_{kn} = \sum_{m=1}^N A_{km} A_{mn}^* = \sum_{m=1}^N c_{m0} \sqrt{c_{k0}c_{n0}} \frac{\gamma_{km}(X, T) \gamma_{mn}(X, T)}{(\eta_k + \eta_m)(\eta_m + \eta_n)}.$$

Denoting $\Delta = \det[\mathbf{I} + \mathbf{C}]$, we differentiate the right-hand side of the expression for the slope solution to get

$$\frac{\partial^2}{\partial X^2} \ln \Delta = \frac{\Delta \partial_X^2 \Delta - (\partial_X \Delta)^2}{\Delta^2},$$

which implies further

$$\frac{\partial u}{\partial X} = 2 \frac{\sqrt{\Delta \partial_X^2 \Delta - (\partial_X \Delta)^2}}{\Delta}.$$

The first piece of the above code is used to generate the determinant $\Delta = \det[\mathbf{I} + \mathbf{C}]$, while the next one is aimed at computing the slope $\partial u / \partial X$. The graph of $\partial u / \partial X$ is plotted with the usual Plot Command. Using this *Mathematica* code, one can reproduce Fig. 8.10 shown at the end of Section 8.4.

EXERCISE 8.11. Prove the identities $K_1 = 0$, $K_2 = K_3$.

Solution. Since K_1 is given as an integral over a closed contour, K_1 vanishes if its integrand is a full differential of a function. To show that this is the case let us compute the following derivative

$$\begin{aligned} D_1 &= \frac{d}{d\phi} \left[2 \sqrt{\frac{(\phi - b_2)(\phi - b_3)}{b_1 - \phi}} \right] \\ &= \sqrt{\frac{\phi - b_3}{(\phi - b_2)(b_1 - \phi)}} + \sqrt{\frac{\phi - b_2}{(\phi - b_3)(b_1 - \phi)}} + \frac{1}{b_1 - \phi} \sqrt{\frac{(\phi - b_2)(\phi - b_3)}{b_1 - \phi}} \\ &= \frac{1}{\phi - b_1} \sqrt{\frac{2}{f(\phi)}} [(\phi - b_3)(\phi - b_1) + (\phi - b_2)(\phi - b_1) - (\phi - b_2)(\phi - b_3)] \\ &= \frac{\sqrt{2}(\phi^2 - 2b_1\phi + b_1b_2 + b_1b_3 - b_2b_3)}{(\phi - b_1)\sqrt{f(\phi)}}, \end{aligned}$$

where $f(\phi)$ is equal to

$$f(\phi) = 2(b_1 - \phi)(\phi - b_2)(\phi - b_3).$$

We see that $D_1/\sqrt{2}$ is exactly the integrand standing in the integral of K_1 , which implies that K_1 vanishes.

Now, we prove that the difference $K_2 - K_3$ also vanishes using the same argument. Subtracting K_3 from K_2 , we obtain

$$K_2 - K_3 = \frac{b_2 - b_3}{4\pi} \oint \frac{\phi^2 - 2b_1\phi + b_1b_2 + b_1b_3 - b_2b_3}{(\phi - b_2)(\phi - b_3)\sqrt{f(\phi)}} d\phi.$$

Then we consider the following derivative

$$\begin{aligned} D_2 &= \frac{d}{d\phi} \left[\sqrt{\frac{2(b_1 - \phi)}{(\phi - b_2)(\phi - b_3)}} \right] \\ &= -\frac{1}{\sqrt{f(\phi)}} - \frac{b_1 - \phi}{(\phi - b_2)\sqrt{f(\phi)}} - \frac{b_1 - \phi}{(\phi - b_3)\sqrt{f(\phi)}} \\ &= -\frac{(\phi - b_2)(\phi - b_3) + (b_1 - \phi)(\phi - b_2) + (b_1 - \phi)(\phi - b_3)}{(\phi - b_2)(\phi - b_3)\sqrt{f(\phi)}} \\ &= \frac{\phi^2 - 2b_1\phi + b_1b_2 + b_1b_3 - b_2b_3}{(\phi - b_2)(\phi - b_3)\sqrt{f(\phi)}}. \end{aligned}$$

Thus, the integrand in the above formula for $K_2 - K_3$ is again the full differential and consequently, the integral vanishes.

EXERCISE 8.12. Derive equations (8.73) directly from the conservation law of KdV equation

$$u_t + (3u^2 + u_{xx})_x = 0.$$

Find its solution.

Solution. Let us average the above equation over a unit length (having \bar{k} solitons) to obtain

$$\bar{u}_t + 3(\bar{u}^2)_x = 0.$$

Since there are \bar{k} solitons in a unit length, the average values should be

$$\bar{u} = \bar{k} \int_{-\infty}^{\infty} u_1 dx, \quad \bar{u}^2 = \bar{k} \int_{-\infty}^{\infty} u_1^2 dx,$$

where u_1 is a single soliton solution having the amplitude a , and the integrals are computed approximately by extending the unit interval to the whole real axis. Now, for the single soliton given by

$$u_1 = a \operatorname{sech}^2[\sqrt{a/2}(x - 2at)],$$

the integration yields

$$\bar{u} = 2\sqrt{2}\bar{k}\sqrt{a}, \quad \bar{u}^2 = \frac{4\sqrt{2}}{3}\bar{k}a^{3/2}.$$

The average equation becomes

$$(\bar{k}\sqrt{a})_t + (2\bar{k}a^{3/2})_x = 0.$$

Keeping in mind that the phase velocity c , in case of solitons, is $c = 2a$, we obtain from the kinematic condition $\bar{k}_t + (c\bar{k})_x = 0$ the following equation

$$\bar{k}_t + (2a\bar{k})_x = 0.$$

We rewrite the above equation as $(\bar{k}\sqrt{a})_t + (c\bar{k}\sqrt{a})_x = 0$, expand the derivatives and factorize appropriately to obtain

$$\sqrt{a}[\bar{k}_t + (c\bar{k})_x] + \frac{\bar{k}}{2\sqrt{a}}(a_t + ca_{,x}) = 0.$$

The second equation of (8.73) follows from the above equation plus the consistency condition.

In this approximation the system is not strictly hyperbolic, but a may be found by integration along the characteristics $dx/dt = 2a$. Along this curve, the amplitude a remains constant, due to

$$\frac{da}{dt} = a_t + \frac{dx}{dt}a_{,x} = 0.$$

Thus,

$$\frac{dx}{dt} = 2a = 2C \quad \Rightarrow \quad \frac{x}{t} = 2C,$$

where C is a constant characterizing such a curve. By varying this constant, one can obtain the solution $a = a(x,t)$ spanned in the whole plane (x,t)

$$a(x,t) = \frac{x}{2t}.$$

With this solution the first equation, after some algebra, is reduced to

$$\partial_t(t\bar{k}) + x\bar{k}_{,x} = 0.$$

Changing the unknown function $q = t\bar{k}$, we obtain

$$q_{,t} + \frac{x}{t}q_{,x} = 0,$$

which admits a simple solution $q(x,t) = f(x/t)$, where f is an arbitrary function. Thus, the average number of solitons is

$$\bar{k} = \frac{1}{t}f\left(\frac{x}{t}\right).$$

However, to achieve the full agreement, solution $a(x,t) = x/2t$ has to be cut off at some leading solitary wave in the sequence. This is equivalent to posing jump conditions on the shock waves. If we accept (8.73), the jump conditions have to be

$$\begin{aligned} -V[[\bar{k}\sqrt{a}]] + [[2\bar{k}a^{3/2}]] &= 0, \\ -V[[\bar{k}]] + [[2a\bar{k}]] &= 0, \end{aligned}$$

where V is the velocity of the discontinuity and $[[\cdot]]$ denotes the jump. A jump from $a = 0$ to a nonzero value $a^{(0)}$ would therefore have $V = 2a^{(0)}$. This is the phase velocity and the result indicates that the solution $a(x,t) = x/2t$ may be cut off at a leading solitary wave in the sequence.

Notation

Time t

Generalized coordinates $q = (q_1, \dots, q_n)$

Generalized velocities $\dot{q} = (\dot{q}_1, \dots, \dot{q}_n)$

Generalized accelerations $\ddot{q} = (\ddot{q}_1, \dots, \ddot{q}_n)$

Generalized impulses $p = (p_1, \dots, p_n)$

Kinetic energy $K(q, \dot{q})$

Potential energy $U(q)$

Lagrange function $L(q, \dot{q}) = K(q, \dot{q}) - U(q)$

Hamilton function $H(q, p)$

Dissipation function $D(q, \dot{q})$

Frequency ω

Period T

Amplitude a

Wave number k

Wavelength λ

Phase θ

Element of volume, area, and length dx, da, ds

Greek indices run through 1,2,3 and denote the cartesian components of vectors and tensors

Latin indices run through 1, . . . , n and numerate the degrees of freedom

References

1. Ablowitz, M.J., Clarkson, P.A.: Solitons, Nonlinear Evolution Equations and Inverse Scattering. Cambridge University Press, Cambridge (1991)
2. Ablowitz, M.J., Kaup, D.J., Newell, A.C., Segur, H.: Method for solving sine-Gordon equation. *Physical Review Letters* 30, 1262–1264 (1973)
3. Abramowitz, M., Stegun, I.A.: *Handbook of Mathematical Functions*. Dover Publications, New York (1965)
4. Andronov, A.A., Vitt, A.A., Khaikin, S.E.: *Theory of Oscillators*. Dover Publications, New York (1987)
5. Arnold, V.I.: *Mathematical Methods of Classical Mechanics*. Springer, Berlin (1989)
6. Bender, C.M., Orszag, S.A.: *Advanced Mathematical Methods for Scientists and Engineers: Asymptotic Methods and Perturbation Theory*. Springer, Berlin (1999)
7. Berdichevsky, V.L.: Variational-asymptotic method for constructing shell theory. *Applied Mathematics and Mechanics (PMM)* 43, 664–687 (1979)
8. Berdichevsky, V.L.: *Variational Principles of Continuum Mechanics*, vol. 1 and 2. Springer, Berlin (2009)
9. Bogoliubov, N.N., Mitropolski, J.A.: *Asymptotic Methods in the Theory of Non-Linear Vibrations*. Nauka, Moscow (1974)
10. Chakraborty, T., Rand, R.H.: The transition from phase locking to drift in a system of two weakly coupled van der Pol oscillators. *International Journal of Non-Linear Mechanics* 23(5), 369–376 (1988)
11. Coddington, E.A., Levinson, N.: *Theory of Ordinary Differential Equations*. McGraw-Hill, New York (1972)
12. Courant, R., Hilbert, D.: *Methods of Mathematical Physics*, vol. 1 and 2. Interscience, New York (1953)
13. Doetsch, G.: *Theory and Applications of the Laplace-Transform*. Chelsea, New York (1965)
14. Feynman, R.P., Leighton, R.B., Sands, M.: *The Feynman Lectures on Physics*, vol. 2. Addison Wesley, Reading (1966)
15. Flavin, J.N., Knops, R.J., Payne, L.E.: Energy bounds in dynamical problems for a semi-infinite elastic beam. In: *Elasticity: Mathematical Methods and Applications*, pp. 101–111. Ellis-Horwood, Chichester (1989)
16. Gardner, C.S., Greene, J.M., Kruskal, M.D., Miura, R.M.: Method for solving the Korteweg-deVries equation. *Physical Review Letters* 19, 1095–1097 (1967)
17. Gelfand, I.M., Fomin, S.V.: *Calculus of Variations*. Prentice-Hall, New Jersey (1963)

18. Gelfand, I.M., Levitan, B.M.: On the determination of a differential equation from its spectral function. *Izvestiya Rossiiskoi Akademii Nauk. Seriya Matematicheskaya* 15(4), 309–360 (1951)
19. Gradshteyn, I.S., Ryzhik, I.M.: *Table of Integrals, Series, and Products*. Academic Press, San Diego (2000)
20. Guckenheimer, J., Holmes, P.: *Nonlinear Oscillations, Dynamical Systems, and Bifurcations of Vector Fields*. Springer, New York (1983)
21. Hamilton, W.R.: On a general method in dynamics. Part II. *Philosophical Transactions of the Royal Society*, 95–114 (1835)
22. Kac, M.: Can one hear the shape of a drum. *American Mathematical Monthly* 73(4), 1–23 (1966)
23. Katō, T.: *Perturbation Theory for Linear Operators*. Springer, Berlin (1995)
24. Kirchhoff, G.: Über das Gleichgewicht und die Bewegung einer elastischen Scheibe. *Journal für die Reine und Angewandte Mathematik* 40, 51–88 (1850)
25. Kolmogorov, A.N.: On conservation of conditionally periodic motions for a small change in Hamiltons function. *Doklady Akademia Nauk SSSR* 98(4), 527–530 (1954)
26. Korteweg, D.J., de Vries, G.: On the change of form of long waves advancing in a rectangular canal, and on a new type of long stationary waves. *Philosophical Magazine* 39(240), 422–443 (1895)
27. Kunin, I.A.: *Elastic Media with Microstructure*. Springer, Berlin (1983)
28. Lamb, H.: On the propagation of tremors over the surface of an elastic solid. *Philosophical Transactions of the Royal Society A* 203, 1–42 (1904)
29. Lanczos, C.: *The Variational Principles of Mechanics*. Dover Publications, New York (1970)
30. Lax, P.D.: Integrals of nonlinear equations of evolution and solitary waves. *Communications on Pure and Applied Mathematics* 21(5), 467–490 (1968)
31. Le, K.C.: *Vibrations of Shells and Rods*. Springer, Berlin (1999)
32. Lindstedt, A.: Über die Integration einer für die Störungstheorie wichtigen Differentialgleichung. *Astronomische Nachrichten* 103, 211–220 (1882)
33. Love, A.E.H.: *A Treatise on the Mathematical Theory of Elasticity*, 4th edn. Cambridge University Press, Cambridge (1927)
34. Lyapunov, M.: *The General Problem of the Stability of Motion*. Princeton University Press, Princeton (1947)
35. Mathieu, E.: Mémoire sur le mouvement vibratoire d'une membrane de forme elliptique. *Journal de Mathématiques Pures et Appliquées*, 137–203 (1868)
36. Nayfeh, A.H., Mook, D.T.: *Nonlinear Oscillations*. Wiley-VCH (1995)
37. Noble, B., Daniel, J.W.: *Applied Linear Algebra*. Prentice-Hall, Englewood Cliffs (1969)
38. Onsager, L.: Reciprocal relations in irreversible processes. *Physical Review* 37(4), 405–426 (1931)
39. Percival, I.C.: A variational principle for invariant tori of fixed frequency. *Journal of Physics A: Mathematical and General* 12, L57 (1979)
40. Poincaré, H.: *New Methods of Celestial Mechanics*. Springer, Berlin (1992)
41. Press, W.H., Flannery, B.P., Teukolsky, S.A., Vetterling, W.T.: *Numerical Recipes. The Art of Scientific Computing*, vol. 3. Cambridge University Press, Cambridge (2007)
42. Preumont, A.: *Vibration Control of Active Structures: an Introduction*. Kluwer Academic Publishers, Dordrecht (2002)
43. Rand, R.H.: *Lecture Notes on Nonlinear Vibrations*. The Internet-First University Press, New York (2004)
44. Rayleigh, J.W.: On waves propagated along the plane surface of an elastic solid. *Proceeding of London Mathematical Society* 17(253), 4–11 (1885)

45. Rayleigh, J.W.: *The Theory of Sound*, 2nd edn. Dover Publications, New York (1945)
46. Salamon, D., Zehnder, E.: KAM theory in configuration space. *Commentarii Mathematici Helvetici* 64(1), 84–132 (1989)
47. Sneddon, I.N.: *Fourier Transforms*. Dover Publications, New York (1995)
48. Timoshenko, S.: *Vibration Problems in Engineering*. D. Van Nostrand Company, Princeton (1955)
49. Vakakis, A.F., Rand, R.H.: Normal modes and global dynamics of a two-degree-of-freedom non-linear system- I. Low energy. *International Journal of Non-linear Mechanics* 27, 861–874 (1992)
50. van der Pol, B.: On relaxation-oscillations. *Philosophical Magazine* 2(11), 978–992 (1926)
51. Watson, G.N.: *A Treatise on the Theory of Bessel Functions*. Cambridge University Press, Cambridge (1995)
52. Weinstein, A.: Normal modes for nonlinear Hamiltonian systems. *Inventiones Math.* 20, 47–57 (1973)
53. Whitham, G.B.: *Linear and Nonlinear Waves*. Wiley Interscience, New York (1974)
54. Zabusky, N.J., Kruskal, M.D.: Interaction of solitons in a collisionless plasma and the recurrence of initial state. *Physical Review Letters* 15(6), 240–243 (1965)
55. Zienkiewicz, O.C., Taylor, R.L.: *The Finite Element Method*. Elsevier Butterworth-Heinemann, Oxford (2006)
56. Zygmund, A.: *Trigonometric Series*, vol. 1 and 2. Cambridge University Press, New York (1959)

Index

- absorber 64
- acceleration 4
- acoustics 127
- action functional 65, 126
- action-angle variables 302
- adiabatic invariants 364
- air resistance 4
- amplitude 7, 183, 229, 233
- amplitude modulation 50, 368
- angular momentum 258
- angular time 211
- angular velocity 257
- anti-resonance 62, 77
- attractor 232
- autonomous system 207
- average Lagrangian 186, 361, 372, 380

- bar 106
- beam
 - Bernoulli-Euler 110
 - Timoshenko 127
- beating 50, 276
- bending moments 121
- Bessel equation 118, 123
- bifurcation 281
 - Hopf 281, 326
 - saddle-node 281
- body
 - elastic 128
 - piezoelectric 128
- Bogoliubov-Mitropolsky method 235
- Brillouin zone 101

- Cantor set 315

- Cartesian coordinates 114
- caustics 160
- center 9
- centrifugal energy 238
- chain of oscillators 99
- chaotic motion 302
- characteristic equation 12, 71
- characteristics 159
- Chladni figures 125
- clamped edge 120
- collision 349
- cone coordinates 375
- conservation of energy 8, 66, 129, 209, 301
- conservative system 65, 207, 300
- consistency condition 212
- coupling factor 55
- crest 153

- d'Alembert solution 152
- damper 10
- damping
 - exhaustive 55
 - permeating 55
 - proportional 55
 - turbulent 217
 - viscous 4
- damping constant 10
- decay rate 14, 58
- degree of freedom 3, 65
- determinant 49
- diagonalization 51, 73
- diophantine condition 314
- dispersion relation 103, 161

- nonlinear 345, 372, 385
 - Rayleigh-Lamb 172
- dissipation function 10, 68, 134, 226, 232, 320, 366
- dissipative system 10, 68, 134, 215, 232, 366
- divisor 317
- Duffing equation 208
- Duhamel formula 25

- eigenfrequency 7
- eigenfunction 108
- eigenvalue 71
- eigenvalue problem 70
- eigenvector 49, 71
- eikonal equation 159
- Einstein summation convention 128
- eliminator 62
- elliptic function 213
- elliptic integral 213
- energy
 - internal 106
 - kinetic 4, 66
 - potential 4, 66
 - total 9, 66
- energy balance 19, 26, 68, 180, 219, 227, 367
- energy dissipation 20, 68, 367
- energy flux 180
- energy household 226
- energy level 210
- energy level surface 303
- energy source 222
- entrainment 276
- envelope 14
- equilibrium 67
- ergodicity 315
- Euler-Lagrange equation 129
- excitation 20
- extremal 4

- fast variable 184, 360
- first integral 209
- fixed point 9, 272
- Floquet theory 263
- flow
 - Hamilton 301
 - slow 262
- focus 18

- force 4
 - external 69
- forced Duffing equation 269
- forced van der Pol equation 275
- Fourier series 234
- Fourier transform 101, 162
- free edge 120
- free-body diagram 4
- frequency
 - cutoff 174
- frequency-locked 276
- friction 216

- Gauss theorem 129
- Gelfand-Levitan equation 353
- generalized coordinate 65
- generalized impulse 300
- generalized velocity 65
- geometrical optics 158
- gravity 5

- Hamilton equations 299, 363
- Hamilton principle 65, 121, 126
- Hamilton-Jacobi equation 328
- harmonic excitation 76
- Helmholtz equation 158
- Hermitian operator 178
- Hessian 319
- Hill equation 264
- holonomic constraint 209
- homoclinic orbit 304
- Huygens principle 159
- hysteresis loop 275

- impact 142
- integrable system 302
- invariant tori 302
- inverse scattering transform 350

- jump 236, 275, 289, 402

- KAM theory 312
- kinematic relation 167
- Klein-Gordon equation 160
- Korteweg-de Vries equation 343
 - linearized 160

- Lagrange equation 66
- Lagrange function 4, 66
- Lagrangian 127

- Lamé constants 170
- Laplace transform 23
- Lax pair 351
- Legendre equation 359
- Legendre transform 300
- Lehr damping ratio 19
- Liénard theorem 227
- limit cycle 226
- Lindstedt-Poincaré method 213
- linearization 256
- Liouville theorem 301
- Lissajous figure 87
- logarithmic decrement 16

- magnification factor 29
- mass 4
- mass density 120
- Mathieu equation 256
- matrix
 - damping 69
 - mass 67
 - modal 73, 75
 - stiffness 67
 - transmittance 63, 76
- membrane
 - circular 118
 - rectangular 116
- modal decomposition 75
- modal equation 306
- moment 5
- moment of inertia 6
- motion
 - aperiodic 16
 - fast 237
 - harmonic 7
 - limit 210
 - periodic 32
 - quasiperiodic 312
 - slow 229
- multi-scale 370

- Newton iteration 316
- Newton rule 176
- Newton second law 4
- node 19
- non-autonomous system 70, 255
- nonlinear normal mode 304
- normal mode 50, 73
- normalization condition 112

- numerical simulation 303

- Onsager principle 55, 68
- operator
 - damping 134
 - stiffness 130
- orthogonality 132
- oscillator
 - continuous 126
 - coupled 45, 297
 - damped 10
 - forced 21
 - harmonic 3
 - nonlinear 207
 - self-excited 222
- oscillograph 15

- parametric resonance 255
- Parseval identity 102
- pendulum 5
- period 8
 - conditional 14
- phase 29, 153, 161, 211, 373, 378
 - initial 7
- phase curve 8
- phase plane 8
- phase portrait 8, 209, 217
- phase shift 349, 358, 393
- phase space 301
- plate
 - circular 122
 - Kirchhoff 120
 - Reissner-Mindlin 127
- Poincaré map 268, 303
- Poincaré-Bendixson theorem 226
- Poisson formula 157
- Poisson ratio 171
- polar coordinates 118, 278
- power 31, 223
 - active 32
 - idle 32
- propagating crack 376
- pseudo-resonance 77

- quasicontinuum 101
- quasiperiodic function 263

- ray 158
- Rayleigh equation 226
- Rayleigh quotient 73

- Rayleigh surface wave 197
- reflection 154
- reflection coefficient 154
- refraction 154
- relaxation oscillation 229
- resonance 31, 77
- resonance function 64
- resonant (secular) term 213
- rotating frame 238
- Routh-Hurwitz criterion 56

- saddle point 210
- scattering data 354
- Schrödinger equation 351
- self-adjointness 132
- separation of variables 123
- separatrix 210
- shock wave 402
- signaling problem 179
- Sine-Gordon equation 346
- slope modulation 370
- slow variables 184, 360
- Snell law 154
- soliton 344
- solvability condition 186
- spectral analysis 355
- spectrum 132
- spiral 18
- spring
 - hardening 208
 - linear 4
 - nonlinear 207
 - softening 208
 - spiral 6
- stability 257
- stability analysis 230
- stability chart 265
- steady-state response 275
- step function 22
- strain 106
- string 104
- strip problem 185, 361, 370, 379
- subharmonic resonance 292
- supported edge 121
- swing 257
- switcher 222
- synchronization 320

- Taylor series 67

- time
 - fast 237
 - slow 233
- time scale 14
- tongue of instability 263
- torus 302
 - non-resonant 314
 - resonant 314
- train of solitons 376, 387
- transition curve 266
- transport equation 159
- trough 153
- truncation 135
- turning point 219
- two-timing 233

- unit step response 23

- van der Pol equation 226
- variation 65
- variational-asymptotic method 183, 211, 233, 261, 270, 276, 305, 312, 359
- velocity
 - group 164
 - phase 161
- vibration
 - control 59
 - damped 14
 - elimination 62, 77
 - finite amplitude 207
 - flexural 111
 - forced 26
 - free 8
 - longitudinal 106
 - node 109
 - small 3
 - torsional 107
- vorticity 217

- wave
 - acoustic 152
 - backward 178
 - branch of 153
 - cnoidal 345
 - dispersive 160
 - hyperbolic 151
 - plane 153
 - spherical 157
 - water 343
- wave number 103

- wave packet 167
- wave vector 153, 161
- wavefront 157
- waveguide 169
- wavelength 103
- Whitham equations 377
- Whitham method 185
- winding numbers 313
- WKB-method 158
- work 26, 70
 - active 32
 - idle 32
- Wronskian 265
- Young modulus 107
- zero level 6
- zeros 15