

Advances in Mathematics Education

Sixto Romero Sanchez

Ana Serradó Bayés

Peter Appelbaum

Gilles Aldon *Editors*

# The Role of the History of Mathematics in the Teaching/ Learning Process

A CIEAEM Sourcebook



Springer

# **Advances in Mathematics Education**

## **Series Editors**

Gabriele Kaiser, University of Hamburg, Hamburg, Germany

Bharath Sriraman, University of Montana, Missoula, MT, USA

## **Editorial Board Members**

Marcelo C. Borba, São Paulo State University, São Paulo, Brazil

Jinfa Cai, Newark, NJ, USA

Christine Knipping, Bremen, Germany

Oh Nam Kwon, Seoul, Korea (Republic of)

Alan Schoenfeld, University of California, Berkeley, Berkeley, CA, USA

Advances in Mathematics Education is a forward looking monograph series originating from the journal ZDM – Mathematics Education. The book series is the first to synthesize important research advances in mathematics education, and welcomes proposals from the community on topics of interest to the field. Each book contains original work complemented by commentary papers.

Researchers interested in guest editing a monograph should contact the series editors Gabriele Kaiser ([gabriele.kaiser@uni-hamburg.de](mailto:gabriele.kaiser@uni-hamburg.de)) and Bharath Sriraman ([sriramanb@mso.umt.edu](mailto:sriramanb@mso.umt.edu)) for details on how to submit a proposal.


Sixto Romero Sanchez • Ana Serradó Bayés  
Peter Appelbaum • Gilles Aldon  
Editors

# The Role of the History of Mathematics in the Teaching/Learning Process

A CIEAEM Sourcebook


 Springer

*Editors*

Sixto Romero Sanchez   
University of Huelva  
Huelva, Spain

Ana Serradó Bayés  
La Salle-Buen Consejo  
Cadiz, Spain

Peter Appelbaum  
School of Education  
Arcadia University  
Philadelphia, PA, USA

Gilles Aldon   
Institut Francais de l'Éducation  
Université Lyon  
LYON CEDEX 07, France

ISSN 1869-4918

ISSN 1869-4926 (electronic)

Advances in Mathematics Education

ISBN 978-3-031-29899-8

ISBN 978-3-031-29900-1 (eBook)

<https://doi.org/10.1007/978-3-031-29900-1>

© The Editor(s) (if applicable) and The Author(s), under exclusive license to Springer Nature Switzerland AG 2023

This work is subject to copyright. All rights are solely and exclusively licensed by the Publisher, whether the whole or part of the material is concerned, specifically the rights of translation, reprinting, reuse of illustrations, recitation, broadcasting, reproduction on microfilms or in any other physical way, and transmission or information storage and retrieval, electronic adaptation, computer software, or by similar or dissimilar methodology now known or hereafter developed.

The use of general descriptive names, registered names, trademarks, service marks, etc. in this publication does not imply, even in the absence of a specific statement, that such names are exempt from the relevant protective laws and regulations and therefore free for general use.

The publisher, the authors, and the editors are safe to assume that the advice and information in this book are believed to be true and accurate at the date of publication. Neither the publisher nor the authors or the editors give a warranty, expressed or implied, with respect to the material contained herein or for any errors or omissions that may have been made. The publisher remains neutral with regard to jurisdictional claims in published maps and institutional affiliations.

This Springer imprint is published by the registered company Springer Nature Switzerland AG  
The registered company address is: Gewerbestrasse 11, 6330 Cham, Switzerland

# Acknowledgements and Contributor Information

This book is a result of the work done by participants in the conferences of the International Commission for the Study and Improvement of Mathematics Teaching (CIEAEM, Commission Internationale pour l'Etude et l'Amélioration de l'Enseignement des Mathématiques), which were held in 2017 in Berlin (Germany), 2018 in Mostaganem (Algeria), and 2019 in Braga (Portugal). It is also the result of discussions between CIEAEM members throughout recent years, locally and internationally, taking advantage of remote meetings, particularly two online commission meetings in 2021 and 2022. During these years, and despite the challenges created by necessary health restrictions, CIEAEM members remained true to the founding principles of the Commission, which, since its foundation in 1950, investigates the actual conditions and future possibilities for changes and developments in mathematics education in order to improve the quality of teaching and learning mathematics. As quoted in the 2000 Manifesto of the commission: "In its work, the Commission follows the humanist tradition of the founders of CIEAEM to integrate the scientific goal of research in mathematics education with the political goal to improve the quality of mathematics education with respect to general education: to educate people who are more rationally acting, critically and consciously thinking as citizens as well as future scientists by using and applying mathematical reasoning and mathematical tools."

As editors of this book, we would like to warmly thank every participant in our 2017, 2018, and 2019 conferences, for their role in the development of this theme around the *Histor(ies) of Mathematics*, and especially each author who participated in the commission's reflections as we compiled this volume:

Gilles Aldon is PhD in Mathematics education (University of Lyon) and president of the CIEAEM since 2017. His main research topic is the use of technology in the teaching and learning of mathematics. In particular, he is interested in teaching and learning in the digital age, and in the contribution of technology to student assessment and the problem-solving process.

Peter Appelbaum is a professor and director of Art Education and Education Studies Programs at Arcadia University in Philadelphia, USA. His scholarship

focuses on mathematics education in and out of school as preparation for anticipating and responding to global crises, and on mathematics as the art for creating communities characterized by joy, a can-do attitude, and the courage to act on their convictions. He is the founder of the Youth Mathematician Laureate Project, YMLP.org.

Marcelo Bairral is a senior professor in Institute of Education at the Federal Rural University of Rio de Janeiro (UFRRJ). He was also a president of Brazilian Society of Mathematics Education (July 17, 2019, until July 17, 2022) and a member of Education Committee at CNPq (Ministry of Science and Technology), Brazil.

Giulia Bini is currently a post-doc at the Department of Mathematics of the University of Turin. Her PhD thesis was about the conceptualization of mathematical memes as educational resources, with a focus on the role of technology and digital culture for the teaching and learning of mathematics. Her research interests include inclusion and creativity in mathematics teaching and learning, the representation of mathematical objects, and the connections between digital culture and school mathematics culture.

Maria Elisabette Brisola Brito Prado holds PhD in Education (Curriculum). She is a professor of the Postgraduate Program in Mathematics Education at the Anhanguera University of São Paulo (Brazil). She was a retired researcher at the Center for Informatics Applied to Education – NIED at the State University of Campinas.

Ana Maria Costa is a professor at the Polytechnic of Viseu – School of Education (Portugal). She holds a PhD in American Studies – American history, culture, and literature. She is a member of the editorial board of several international journals.

Javier Díez-Palomar is an associate professor in mathematics education at the University of Barcelona. He is president of the AMIE (Association of Multidisciplinary Research in Education) associated with WERA (World Educational Research Association), a member of CIEAEM (Commission for the Study and Improvement of Mathematics Teaching), and a member of the Numeracy Expert Group at PIAAC (OECD). He is chief editor of *REDIMAT: Journal of Research in Mathematics Education*. He has been a PI for many national and international RTD research projects on mathematics education.

Susan Gerofsky is an associate professor of Mathematics Education and Environmental Education at the University of British Columbia, Vancouver, BC, Canada. Her interdisciplinary research is in embodied, multisensory, multimodal mathematics education through arts, movement, gesture, and voice. She works in curriculum studies and has taught a course on History of Mathematics for Teachers for more than five years now. She is active as a poet, playwright, musician, and filmmaker, and works with dance and fiber arts. You'll often find her cycling around town with a baritone horn or an accordion.

Joaquín Giménez Rodríguez is a full professor in didactics of mathematics at the Faculty of Education of the University of Barcelona; member of the International Commission for the Study and Improvement of Mathematics Education (CIEAEM), as well as other national and international research networks in mathematics education; and member of the research group on virtual teaching and learning (GREAV).

He has been PI of international research projects in mathematics education. He is author of school books and of numerous chapters and research articles on *Mathematics Education*, mainly on teaching and learning of algebra and geometry.

David Guillemette is a professor at the Department of Mathematics of the Université du Québec, Montréal. From a cultural-historical perspective in mathematics education, his research interests focus on the historical, cultural, social, and political dimensions of mathematics in the context of teacher education.

Fernando Hitt is a professor of mathematics education at the University of Quebec in Montreal (Canada). His main research is about the use of technology in the learning and teaching of mathematics in the classroom.

Sonia Kafoussi is a professor of Didactics of Mathematics at the University of the Aegean, in Greece, at the Department of Sciences of Preschool Education and Educational Design. Her research interests mainly concern the development of children's mathematical thinking in early childhood and the role of parental involvement in mathematics education.

Fragkiskos Kalavasis is a professor of Didactics of Mathematics and Educational Engineering, Faculty of Human Sciences, University of the Aegean, Greece. His research focuses on the link between the diversity of mathematical thought at school (as reflective construction) and the diversity of mathematical expressions in other scientific disciplines. He pursues deeper systemic interaction of such interdisciplinary learning through models of schools as learning organizations interconnecting with the family and social environment.

Carmen Leon-Mantero holds a PhD in Social and Legal Sciences from Universidad de Córdoba. She is an assistant professor in the Department of Mathematics at the Universidad de Córdoba, lecturing in early childhood and primary teacher training degrees, as well as secondary teacher training at the master's level. Her research interests include history of mathematics education, attitudes toward mathematics, bibliometrics, and teacher training.

Nielce Meneguelo Lobo da Costa has PhD in Education (Curriculum) and Post-Doctorate in Educational Technology. She is a professor of the postgraduate program in Mathematics Education at the Anhanguera University of São Paulo (Brazil). She was also a retired math and computer teacher.

José Luis Lupiáñez is a professor in the Department of Didactics of Mathematics at the University of Granada (Spain). His areas of research are STEM education, teacher training, mathematics curriculum, and notion of competence.

María José Madrid holds PhD in Mathematics Education from Universidad de Salamanca. She is an associate professor at Universidad Pontificia de Salamanca, lecturing mainly mathematics didactic in early childhood and primary teacher degrees. Her research interests history of mathematics and mathematics education, attitudes toward mathematics, bibliometrics, and teacher training.

Alexander Maz-Machado holds PhD in Mathematics Education from Universidad de Granada. He is a professor in the Department of Mathematics of the Universidad de Córdoba, lecturing in early childhood and primary teacher training degrees as well as secondary teacher training at master level. His research interests are history of mathematics and mathematics education, science evaluation



and bibliometrics, attitudes and beliefs toward mathematics, and curriculum analysis in higher education.

Cristina Margaritidou has been a secondary school mathematics teacher in Rhodes for 13 years. She holds a master's degree in mathematics and sciences education.

Luís Menezes is a professor at the Polytechnic of Viseu – School of Education (Portugal). He holds a PhD in Didactics of Mathematics. His main research interests are mathematics teaching practices and teacher education. Particularly, his interests pertain to the role of history in the mathematics classroom. He is a member of the editorial board of several international journals.

Andreas Moutsios-Rentzos is an assistant professor in the Department of Pedagogy and Primary Education of the National and Kapodistrian University of Athens in Greece. His research focuses on revealing the complexity of mathematical argumentation, reasoning, and proving across and within different educational levels, as well as on broader systemic approaches of the interdisciplinary mathematical teaching-learning phenomena within an expanded, hybrid educational lifeworld.

Monica Panero, PhD in mathematics, is currently lecturer and researcher in mathematics education at the *Dipartimento formazione e apprendimento of the Scuola universitaria professionale della Svizzera italiana*. Her main research foci are on formative assessment, technology in mathematics education, attitude toward mathematics and its teaching, and mathematics teacher education. She is currently part of the executive board of the International Commission for the Study and Improvement of Mathematics Teaching and part of the scientific committee of the open access semestral journal *Didattica della matematica. Dalla ricerca alle pratiche d'aula*.

Pedro Palhares works at the Institute of Education, University of Minho, in Portugal. He is an associate professor with Aggregation and a member of the Research Center for Child Studies. His main research interests include problem solving, games, and ethnomathematics.

Montserrat Prat holds a PhD in Didactics of Mathematics and a BSc in Mathematics. She is a tenured professor in initial teacher training at the Department of Mathematics Education, Faculty of Psychology, Science of Education and Sport, Blanquerna – URL, Barcelona. She has also been a visiting researcher in England and Chile. She is currently participating in several research and teaching projects. Her main research interests include the social and cultural aspects of mathematics teaching and learning, interdisciplinary learning through mathematics, and early childhood mathematics education.

Sixto Romero Sánchez, PhD in Mathematics, is a professor in the Department of Integrated Sciences, University of Huelva-UHU (Spain). He currently teaches at the Higher Technical School of Engineering (UHU) in the areas of knowledge of mining, electrical, and energy engineering. His research follows two paths: (a) Mathematical modeling in the digital treatment of images; (b) Mathematics education: problem solving and its circular implications.

Ana Serradó Bayés holds a PhD in mathematics education from the University of Cadiz, Spain. She is a middle school teacher at the STEM department of Colegio La

Salle-Buen Consejo in Spain. Her research explores the historical parallelism between the development of the notion of stochasticity and its mathematical education and design-based research on STEAM role-model education for an equalitarian education and a transformative view of teachers' identity.

Carlotta Soldano is currently a temporary researcher ((RTDa) junior lecturer) at the Department of Philosophy and Education Sciences of the University of Torino. She teaches foundations and didactics of mathematics to future kindergarten and primary school teachers who attend the master course in primary education. She obtained the master degree in mathematics and the PhD in mathematics education at the University of Torino. Her main research interests concern the study of geometric reasoning, the development of inquiring-game activities, and the study of the systems of control and of the visualization processes in the teaching and learning of mathematics.

José Luis Soto Munguía is a professor of mathematics education at the University of Sonora (Sonora, Mexico). His main research interests are the use of technology in the teaching and learning of mathematics and the professional development of mathematics teachers.

Charoula Stathopoulou is a professor of Mathematics Education at the University of Thessaly (Greece). She completed a bachelor's degree in mathematics and pursued additional postgraduate study in mathematics education and in social anthropology. Her PhD thesis focused on the connection between cultural context and mathematics learning, for which she conducted fieldwork in a Roma classroom and in the students' community of origin. Roma children's (mathematics) education, together with prison education, form the main foci of her current research.

José Armando Valente is PhD from the Department of Mechanical Engineering and Division for Study and Research in Education at the Massachusetts Institute of Technology (MIT). He was a full professor (retired) at the Department of Multimedia, Arts Institute, and collaborating researcher at the Nucleus of Informatics Applied to Education (NIED) at the State University of Campinas – UNICAMP.

Yuly Vanegas Muñoz is a lecturer professor of Serra Húnter programme in didactics of mathematics at the University of Lleida. She is a member of the research group GIPEAM (Educational Practice and Mathematical Activity). Her research interests include the teaching and learning of mathematics at early ages, teacher training, and interdisciplinary learning through mathematics. She has participated in several national and international research projects on mathematics education. She currently coordinates the IEMI group of the Spanish Society for Research in Mathematics Education (SEIEM) and the "Minor in STEM" of the primary education degree at the University of Lleida.

Sixto Romero  
Ana Serradó Bayés  
Gilles Aldon  
Peter Appelbaum

# The Role of the History of Mathematics in the Teaching/Learning Process

*Mathematics is one of the oldest of sciences; it is also one of the most active; for its strength is the vigour of perpetual youth.*

**Andrew Russell Forsyth (1858–1942)**

*Mathematics is the cheapest science. Unlike physics or chemistry, it does not require any expensive equipment. All one needs for mathematics is a pencil and paper.*

**George Pólya (1887–1985)**

*It matters little who first arrives at an idea, rather what is significant is how far the idea can go.*

**Sophie Germaine (1776–1831)**

*To function efficiently in today's world, you need math. The world is so technical, if you plan to work in it, a math background will let you go farther and faster.*

**Mary Golda Ross (1908–2008)**

Researchers, professors, and teachers who have contributed to annual meetings of the CIEAEM since 2006 have consistently identified the history of mathematics as a focus bringing together many issues and questions about mathematics teaching and learning. Discussion has focused mainly on humanizing mathematics, contextualizing it, and showing our students that it is a product of human activity and that it has developed over millennia of civilization.

CIEAEM, the International Commission for the Study and Improvement of the Teaching of Mathematics, in the aforementioned meetings has managed to bring together the actors involved, including political leaders, to discuss contemporary issues and future directions for collaboration. The incorporation of the History of Mathematics into mathematics education has been a growing thread of conversation at the commission's annual conferences, as well as in the commission's ongoing communications over the past few years. A review of conference presentations, committee meeting topics, and online discussions identified this approach, primarily in terms of the ways in which historical perspectives on mathematics and mathematics education can make mathematics in schools more humane. Contextualizing

mathematics has the potential to show students that the mathematics they are studying and exploring together is a product of human activity, evolving over millennia and taking comparatively different forms in different civilizations.

This recent focus on the history of mathematics continues the commission's interest in mathematics as a human endeavor and also extends the commission's own role in the history of mathematics education. From its founding members to today, CIEAEM has been a meeting site of important figures in mathematics and mathematics education, including Caleb Gattegno, Jean Piaget, Gustave Choquet, Anna Zofia Krygowska, Lucienne Félix, Tamás Varga, Paulo Abrantes, Emma Castelnuovo, Filippo Spagnolo, and Christine Keitel. The French Gustave Choquet (President) and the Swiss psychologist and cognition theorist Jean Piaget (Vice-president) were supported by Caleb Gattegno as secretary. Choquet brought into the discussion the ideas of a reform guided by the restructured new "architecture" of mathematics, Piaget presented his famous results of research in cognition and conveyed new insights into the relationships between mental-cognitive operative structures and the scientific development of mathematics, and Gattegno attempted to connect the new mathematical meta-theory to psychological research by a philosophical and pedagogical synthesis and to create and establish relationships with mathematics education as an important part of general education.

Mathematics as a human creation has been developing for more than four thousand years. It emerged as a response to different social and economic needs of civilizations such as Babylonian, Egyptian, Indian, Chinese, Greek, Roman, Mayan, Aztec, Incan, Navajo, and Inuit, to name but a few. In some early civilizations, the solution to mathematical types of problems lay in empirical research, whereas in later periods deductive theoretical methods were applied (Karaduman, 2010, Clarke, 2003). In all civilizations, whether they are based on writing or oral tradition, mathematics has accompanied the development of the world (Sokhna, 2019). In African and East Asian civilizations, fractal cosmologies and complexification of architecture, design, and community planning fostered aesthetics and theologies foreshadowing what would eventually be "discovered" in Western and European history millennia later (Eglash, 1999, Lu, 2007). Twentieth-century art and philosophy were heavily influenced by mathematical challenges to assumptions about reality and the foundations of rational thought, with mathematics and its uncertainty, the infinity of infinities and their implications, and advanced set theory finding their way into musical composition, the structure of poetry and novels, and theories of social change.

Knowledge of the lives and works of those who created mathematics can be a stimulus for engagement. We are interested in young people having the experience of intellectual pleasure, which is obtained by associating, integrating, relating, and, also, surprising and marveling at Great Ideas and Great Works. Based on that experience, they acquire the desire and the intention to understand, to know, and especially to keep their interest and curiosity in the face of any new challenge.

The teacher must possess this knowledge in order to inculcate such desires and to introduce learners to the various ways in which mathematics has enriched lives and cultures – to introduce learners to those for whom "Mathematics is the alphabet with

which God has written the Universe” (Galileo Galilei, 1619 and Weinberg, 2015), others who, like the eighteenth-century cleric Charles Caleb Colton experienced the wondrous opening of imagination sparked by mathematics – “The study of mathematics, like the Nile, begins in minuteness but ends in magnificence,” yet others who, like the “Indian Calculator” Shakuntala Devi, found that “Without mathematics, there’s nothing you can do. Everything around you is mathematics. Everything around you is number,” or, like, Georg Cantor, that “In mathematics the art of proposing a question must be held of higher value than solving it.” Perhaps most importantly, integrating the history of mathematics into school mathematics helps to foster an understanding of mathematics as integral to all of history, culture, life, meaning, arts, and politics. When teachers enact this conception of mathematics with their students, the mathematics that they jointly create comes to life as part of history for the students as well.

## **What Is the Purpose of Teaching Mathematics from Its History?**

In the first place, introducing young people to various stories of how our science was built (in the course of millennia that preceded us) and presenting its creators (an approach commonly employed in other school subjects, yet oddly rare in most school mathematics) shows mathematics as it is: a product of human activity developed from different stimuli, sometimes to solve practical problems, at other times for artistic or spiritual reasons. Mathematics is, was, and will be in direct relation to the civilizations within which it co-develops and has been evolving. Miguel de Guzmán (2001) justifies this assertion by pointing out that history can provide a truly human vision of mathematics, he adds, “... the historical vision transforms mere facts and skills without soul into portions of knowledge anxiously sought and in many cases with genuine passion. By men of flesh and blood who rejoiced immensely when they first encountered them. (...) The historical perspective brings us closer to mathematics as a human science, not deified, sometimes painfully creepy and sometimes fallible, but also capable of correcting its errors.” When mathematics is studied and developed as having a history, the mathematical discoveries and mathematical skills acquired by learners are understood by these learners as making history themselves.

In the teaching process, special attention should be given to developing positive attitudes of students toward mathematics (Akinsola & Olowojaiye, 2008). One of the ways to achieve this is to show and convince the students that mathematical knowledge can make their life easier and improve it. But most importantly, common sense tells us that mathematics teaching should be organized in a context in which students will eagerly acquire new knowledge by their own intellectual efforts and abilities. One of the pedagogical tools for achieving these goals is the history of mathematics, and we will see how we use this tool in our work. Worldwide, students

are frequently reported as perceiving mathematics to be something foreign, cold, boring, and difficult. It is not necessary to “change” mathematics to teach it; “isolated and naked.” Various proposals suggest leaving the classroom in order to look for mathematics, and find it, for example, in other disciplines, or in the arts and cultures that have developed all around us. Together, this is about contextualizing mathematics through its history.

## *Origins*

In prehistory, at the beginning of the Neolithic period, the concept of natural number appears linked to the need of man to count in order to control his belongings and the first geometric concepts also appear when he makes divisions in the earth (soil) because he learned to sow.

Pottery and loom work, among other new activities, stimulate pattern creation (geometric) in order to decorate pots and pans, as an element of aesthetic order. Nowadays, these concepts are still present in the development of information technology in mathematics education.

As for the origins, among other researchers (Boyer, 1994):

“The interest of prehistoric man for design and spatial relationships may have arisen from his aesthetic sense, to enjoy the beauty of form, motive that also frequently animates the current mathematician. We would like to think that at least some of the primitive geometers did their work only for the pure pleasure of doing mathematics and not as a practical aid for measurement, but there are other alternatives. One of them is that geometry, as well as numeration, had its origin in certain primitive ritual practices. (...) We can only make conjectures about what it was that prompted Stone Age men to count, measure and draw geometric patterns, but what is clear is that the origins of mathematics are more ancient than the oldest civilizations.”

One of the objectives of incorporating history, in Mathematics classes, is to demonstrate its presence in the life of our species through time. In this way it is humanized, showing it as a human activity that has been realized, created, and constructed through centuries and millennia.

The oldest civilizations, Egypt, China, India, and Asiatic Mesopotamia, built wonderful architectural works, mostly dedicated to the cult of the dead and their divinities; in these works, they applied their geometric knowledge while meeting their spiritual and aesthetic needs.

In Greece, mathematics knows its first period of great splendor. Abstraction and generalization appear for the first time within demonstrations and proofs, often attributed to Thales of Miletus. Historians agree that philosophical thinking emerged in the sixth century BC. Philosophers – “lovers of wisdom” – asked themselves questions about natural phenomena, and sought explanations in nature itself (not in the actions and whims of gods). A new current of philosophy is developed in relation

to the evolution of the modes of government and the progress of mathematics as a science. It is there and with those men that Geometry was created, which we continue to study and use today.

Throughout the Middle Ages, while Europe slept in a mystical dream, other cultures, for example Hindu and Arab, continued to develop different aspects of scientific work. As for Mathematics, the most important creations were the decimal, the numerical place-value system including the concept of zero, and the development of Algebra.

### ***Intellectual Horizon in the Incorporation of Elements of the History of Mathematics***

For the teacher, the history of mathematics is inscribed in a space that allows expanding the intellectual horizon of teachers and students willing to address it.

Why do we argue that incorporating elements of the *History of Mathematics in the Teaching Learning Process* facilitates students' mathematics learning?

This incorporation of elements of the *History of Mathematics* to teaching-learning processes facilitates the visualization of the intimate and undeniable link that exists between this scientific discipline and human sociocultural dynamics. Educational benefits obtainable through the history of mathematics include at least the following:

- (a) Promote a change of attitude and beliefs toward mathematics (away from human activity, out of this world, having nothing to do with human needs, perfection, etc.). Mathematics is essentially an activity; therefore, its knowledge is contextual and cannot be separated from its social and historical conditions.
- (b) Help explain and overcome epistemological obstacles, rather than creating the impression that mathematical concepts are especially difficult to understand. This is a student-focused orientation because the historical contexts of mathematics often help to explain the misunderstandings that students present around a particular concept. The "mistakes" of mathematicians in history demonstrate that the ongoing development of mathematical ideas is not linear, but rather the result of successive controversies, disputes, proofs, and refutations leading to results that are accepted at a certain point by the mathematical community – but are always debatable and extendable (Lakatos, 1963/2015).
- (c) Encourage reflection and a critical attitude in the student

The *History of Mathematics* can become a valuable resource in the construction of necessary strategies for training reflective and critical students (who ask what, how, where, and why), because it facilitates the recognition that mathematics is always unfinished, open to criticism and questioning, against the background of its own history. Disclosing the disagreements, the errors, the problems, and the needs that are found in the history of each mathematical concept establishes a rich learning environment. It is not only possible but actually encouraged for a student to express healthy doubts in a classroom

that discusses and also supports mathematics as open to continued contributions from the students themselves.

(d) Integrate mathematics with other disciplines?

There is compatibility between the study of mathematical ideas and the learning of the cultural context that encompasses them. The *History of Mathematics* can help the student connect mathematics with other aspects of human life, such as religion, literature, philosophy, art, and other sciences. One important feature of a historical approach is that it can help a curriculum to avoid a naive, progressive view of history in general: there are many techniques, ideas, and approaches to mathematical ideas and algorithms that have been lost through history, and that have been lost to historical circumstances. Students who have a rich and critical experience with the *History of Mathematics* can better understand the ways in which history is not always an ongoing march of civilization toward utopia. They can also begin to ask questions about the ways that “power dynamics have played out in the history of mathematics, and where mathematics might come to serve the people as opposed to vice versa” (Goffney, et al., 2018).

(e) Increase the interest and motivation of students toward Mathematics

Faced with the diversity of interests existing in people. Likewise, when considering the role that mathematics has played in the evolution of science, technology, and civilization in general, the *History of Mathematics* helps students develop their appreciation for mathematics and enjoy their learning. *History of Mathematics* for specific cultural groups has been employed to create a sense of pride in one’s own cultural heritage (Souviney, 1981, Moses, 2001, Leonard & Martin, 2013), to enhance teacher and student engagement with mathematics through everyday life examples (Csicsery, 2012, Poirier, 2008), and to challenge students to take on an activist role in their local communities (Appelbaum, 2009).

(f) Using the *History of Mathematics* as an introduction to a critical and cultural study of mathematics is one of the most important challenges that mathematics teachers and students can pursue. There are many possibilities in mathematics education for the use of history. What teachers know and understand about mathematics makes a difference in the quality of their teaching (Grugnetti, 2000).

## Proposal to Teach Mathematics with History

1. Design class plans “with history,” that is, by integrating the appropriate historical content with mathematical content.
2. Prepare brief monographs on the life and work of a mathematician, and instead of imposing the topics, students choose among those proposed.
3. Read in class, and in groups, a text referring to the history of mathematics, and then ask questions about it in order to provoke a mathematical conversation.
4. Answer integrating questions, in class, in writing, in groups, on topics already studied, with open and free use of reference books, texts, and student notes.



5. Watch videos about the history of mathematics and solicit comments from students about what makes the session attractive and interesting. Follow up with support for students to pursue research into the history of mathematics in the videos, the lives of the mathematicians mentioned, and in their own investigations of the mathematics included.
6. Orient activities toward the historical contextualization of a concept or topic.
7. See the evolution of concepts throughout history.
8. Recreate the solution of historical mathematical problems.
9. Study the historical impact of mathematical ideas on culture, social structures, politics, art, and community.
10. Use concrete material: technology, visual resources, etc.
11. Assign research work outside of the regular classwork, including the introduction of historical literary expressions related to mathematics (such as verses, dialogues, metaphors, proverbs, and analogies).
12. Assign creative projects that ask students to imagine current mathematics as the history of future mathematical ideas, so that they can see themselves and others as making a history of mathematics in the present day!

In short, the idea is summarized by Wheeler (1980) when he points out: “But I would like that every child, at some point in their schooling, can experience the power and encouragement of mathematics (since they may not have another opportunity) as well as that of all school subjects, so that at the end of their education at least they know what it is like and if it is an activity that has to occupy, or not, a place in their future.”

Huelva University, Huelva, Spain

Sixto Romero

La Salle-Buen Consejo, Spain

Ana Serradó

Institut Francais de l'Éducation,  
Université Lyon, LYON CEDEX 07,  
France

Gilles Aldon

School of Education  
Arcadia University  
Philadelphia, PA, USA

Peter Appelbaum

## References

- Akinsola, M. K., & Olowojaiye, F. B. (2008). Teacher instructional methods and students attitudes towards mathematics. *International Electronic Journal of Mathematics Education*, 3(4), 60–73.
- Appelbaum, P. (2009). Taking Action – mathematics curricular organization for effective teaching and learning. *For the Learning of Mathematics*, 29(2), 38–43.
- Boyer, C. (1994). *Historia de la Matemática*. Alianza Editorial.

- Csicsery, G. (2012). *Navajo Math Circles*. Zala Films.
- Clarke, V. (2003). *Effective Strategies in the Teaching of Mathematics, A Light from Mathematics to Technology*. University Press of America.
- Eglaah, R. (1999). *African fractals. Modern computing and indigenous design*. Rutgers University Press.
- Goffney, I., Gutiérrez, R., & Boston, M. (Eds.) (2018). *Rehumanizing mathematics for Black, Indigenous, and Latinx Students*. (Annual Perspectives in Mathematics Education, Vol. 2018). National Council of Teachers of Mathematics.
- Grugnetti, L. (2000). The History of Mathematics and its Influence on Pedagogical Problems. In V. Katz (Ed.). *Using History to Teach Mathematics An International Perspective*. The Mathematical Association of America (Inc.).
- Guzmán, M. d. (2001). *Tendencias actuales de la educación matemática*. Universidad Complutense de Madrid. Rev. SIGMA-19, 5–25.
- Karaduman, G. B. (2010). A sample study for classroom teachers addressing the importance of utilizing history of math in math education. *Procedia Social and Behavioral Sciences* p. 2689–2691.
- Leonard, J., & Martine, D. (2013). *The brilliance of Black children: Beyond the numbers and toward new discourse*. Information Age Publishing.
- Lu, P. (2007). *Advanced geometry of Islamic art*. BBC News. [http://news.bbc.co.uk/2/hi/middle\\_east/6389157.stm](http://news.bbc.co.uk/2/hi/middle_east/6389157.stm)
- Moses, R. (2001). Organizing algebra. The need to voice a demand. *Social Policy*, 31(4). 4–12.
- Poirier, L. (2008). Teaching mathematics to Inuit children in Nunavik: Taking into account the environment, the culture and the language. *Proceedings of the International Commission on Mathematics Instruction, Monterrey, Mexico, July 6 – 13*.
- Souviney, R. (1981). *Teaching and learning mathematics in the community schools of Papua, New Guinea*. UNESCO Report. ERIC access no. ED229273.
- Weinberg, S. (2015). *Explicar el mundo: el descubrimiento de la ciencia moderna*. Ed.2ª. Taurus.
- Wheeler, D. (1980). *Humanización de la Educación Matemática*. En *Conceptos de Matemática* 55, 7–14.
- Wilson, P. S., & Chauvot, J. B. (2000). Who? How? What? A strategy for using history to teach. *Mathematics Teacher* 93.

# Contents

## Part I The Use of History in the Teaching of Mathematics

- 1 **The Exploration of Inaugural Understandings in the History of Mathematics and Its Potential for Didactic and Pedagogical Reflection** . . . . . 17  
David Guillemette
- 2 **The Value of Historical Knowledge Through Challenging Mathematical Tasks** . . . . . 33  
Luís Menezes and Ana Maria Costa
- 3 **An Historic Approach to Modelling: Enriching High School Student's Capacities** . . . . . 49  
Sixto Romero Sánchez
- 4 **The Introduction of the Algebraic Thought in Spain: The Resolution of the Second Degree Equation** . . . . . 79  
María José Madrid, Carmen León-Mantero,  
and Alexander Maz-Machado

## Part II History of Mathematics and Its Relation to Mathematical Education: Introduction

- 5 **Mathematics Education in Different Times and Cultures** . . . . . 117  
Sixto Romero Sánchez
- 6 **Integrating the History of Mathematics in Mathematics Education: Examples and Reflections from the Classroom** . . . . . 149  
Sonia Kafoussi and Christina Margaritidou
- 7 **Re-constructing the Image of Mathematics Through the Diversity of the Historical Journeys of Famous Mathematicians** . . . 167  
Fragkiskos Kalavasis and Andreas Moutsios-Rentzos

<b>8</b>	<b>History of Ethnomathematics: Recent Developments</b> . . . . .	189
	Peter Appelbaum and Charoula Stathopoulou	
<b>Part III The Role of History in the Process of Training the Mathematician</b>		
<b>9</b>	<b>Problems and Puzzles in History of Mathematics</b> . . . . .	219
	Pedro Palhares	
<b>10</b>	<b>The Potential in Teaching the History of Mathematics to Pre-service Secondary School Teachers</b> . . . . .	233
	Susan Gerofsky	
<b>11</b>	<b>The Role of History in Enriching Mathematics Teachers' Training for Primary Education (6–12 Years Old Students)</b> . . . . .	255
	Yuly Vanegas, Joaquín Giménez, and Montserrat Prat	
<b>12</b>	<b>Recent Trends of History of Mathematics Teacher Education: The Iberic American Tradition</b> . . . . .	273
	Joaquín Giménez and Javier Díez-Palomar	
<b>Part IV Technology in the Recent History of Mathematics Education</b>		
<b>13</b>	<b>Tools and Technologies in a Sociocultural Approach of Learning Mathematical Modelling</b> . . . . .	309
	Fernando Hitt, José-Luis Soto-Munguía, and José-Luis Lupiáñez-Gómez	
<b>14</b>	<b>Technology in Primary and Secondary School to Teach and Learn Mathematics in the Last Decades</b> . . . . .	333
	Giulia Bini, Monica Panero, and Carlotta Soldano	
<b>15</b>	<b>A Trajectory of Digital Technologies Integration in Mathematical Education in Brazil: Challenges and Opportunities</b> . . . . .	361
	Maria Elisabette Brisola Brito Prado, Nielce Meneguelo Lobo da Costa, and José Armando Valente	
<b>16</b>	<b>History, Technology and Dynamic Geometry: From Resources with Static Construction to DGE with Touchscreen</b> . . . . .	381
	Marcelo Bairral	
	<b>Conclusion of the Book</b> . . . . .	401
	<b>References</b> . . . . .	405
	<b>Index</b> . . . . .	455

# Part I

## The Use of History in the Teaching of Mathematics

### Introduction

Ana Serradó Bayés  
Colegio La Salle-Buen Consejo, Puerto Real, Spain  
e-mail: [anaserradobayes@lasallebuenconsejo.es](mailto:anaserradobayes@lasallebuenconsejo.es)

*“As well as looking forward,  
and being alert to new developments,  
you should not forget the past”*  
Atiyah (2014, pp. 1003)

In 2018, when the seminal ideas of this book were discussed during the 70 meeting of the International Commission for the Study and Improvement of Mathematics Teaching (C.I.E.A.E.M), a subtheme of the conference was ‘Rethinking History of Mathematics by Highlighting the Contribution of Different Cultures to the Evolution of Mathematics.’ Although the history of mathematics has not been of primary interest *per se* for some members of the C.I.E.A.M., its usefulness in the teaching and learning of mathematics has been a recurrent issue from the early foundation of the commission. We highlight the persistence of this theme with three examples of renowned C.I.E.A.E.M members throughout the history of the commission. Each grounded their own theories of teaching and learning mathematics through analyzing different perspectives of the possible relationships that can be established between the history of mathematics and its usefulness for the teaching and learning of mathematics.

For Emma Castelnuovo, history goes back to the original ideas and restores intuition against the formalism appearing in the finished theories, echoing the guided reinvention proposed by Hans Freudenthal (Furinghetti & Menghini, 2014). Freudenthal also recognized the importance of history in his *phenomenological analysis of mathematical concepts*. He justified the potential role of history in teacher training by the idea that history contributes to the *profundity* of our mathematical knowledge, and he took the view that historical interventions in mathematics

teaching at school should contribute more to comprehending the general history (of culture) than to comprehending mathematics (Jahnke et al., 2022). Brousseau (1997, 87–8) emphasized epistemological assumptions, stating: “*the obstacles that are intrinsically epistemological are those that cannot and should not be avoided, precisely because of their constitutive role in the knowledge aimed at. One can recognise them in the history of the concepts themselves.*” Following Brousseau, we can recognise a sort of ‘historical parallelism’ between the observation of difficulties and obstacles that appeared in history and those that emerge in the classroom (Harper, 1987; Sfard, 1995; Zornbala & Tzanakis, 2004; Thomaidis & Tzanakis, 2007; Farmaki & Paschos, 2007; Jankvist, 2009).

Castelnouvo, Freudenthal and Brousseau choice two different paradigms, the phylogenesis that seeks to identify a parallelism between historical and psychogenetical developments, and the socio-cultural perspective, which advocates for applying history to the “cultural analysis of the content to be taught.” The second paradigm stresses the importance for teachers to consider the mathematical, historical and cultural aspects of mathematical concepts (Boero & Guala, 2008). These authors present a holistic view of mathematics education, where teachers are challenged to integrate the mathematical, historical and cultural aspects of each mathematical concept they teach. This is a huge challenge for any teacher.

For a non-negligible number of teachers, teaching mathematics has been influenced by an axiomatic approach that relies on formalism as an implicit philosophical thesis. Teaching in this manner is dominated by the presentation of mathematical definitions, axioms, theorems and proofs (Clark et al., 2019). These teachers consider the ‘polished’ products of mathematical activity without considering that this is just one aspect of what constitutes mathematical knowledge. They teach exclusively the part of mathematics which is communicated, criticized (in order to be finally accepted or rejected), and serves as the basis for the new work. This matters for understanding the role of history, for, if one takes mathematics to be essentially unchanging and immortal, then at bottom, there is no difference between past and present. A result of such an orientation is that one may freely translate the mathematics of the past into a modern idiom, and use the present unabashedly as a guide to the past (Fried, 2018). Those teachers act on a commitment to modern mathematics and modern techniques, and are at risk of being whiggish, i.e., ahistorical in their approach (Fried, 2007). They understand mathematics as an intangible heritage, as a way to engage with the past specifically through patterns of selection, interpretation and perseveration that relate it to present purposes (Mazzocchi, 2022). Moreover, they argue against extensive inclusion of history in their teaching, suggesting that historical developments often took place along complicated paths, led to dead ends, and included notions, methods and problems no longer used or otherwise relevant for mathematics nowadays (Clark et al., 2019).

In contrast to that vision of an intangible heritage, Mazzocchi (2022) introduces the idea that cultural heritage demonstrates the value of including historical perspectives in the study of mathematics. “*Heritage is embodied in people, and its creation and maintenance depend on the social structure*” (Mazzocchi, 2022, p. 395). The

concept of cultural heritage applies a dichotomy between history and heritage (Grattan-Guinness, 2004) in a cultural sphere to enable understanding mathematics and its history as distinguished by their respective guiding questions: History asks, “What happened?” or “Why did N happen?”; heritage asks “How did we get here?”. With the ‘history’ of a particular mathematical notion, Grattan-Guinness (2004) refers to the development of a specific notion during a particular period: its launch and early forms, its impact [in the following years and decades], and its application in and/or outside of mathematics. With the ‘heritage’ of a particular mathematical notion, he refers to its impact upon later work, both at the time of its emergence and afterward, especially the forms which it may take, or be embodied, in later contexts. While both approaches are legitimate and important in their own right, mathematicians, mathematic teachers and educators should be aware of such distinctions when dealing with historical considerations (Clark et al., 2019).

The work on the part of the teachers to incorporate the history of mathematics in their teaching is a way of interpreting the mathematics of the past, history or heritage, and thus becomes a way of interpreting and constructing the nature of mathematics that is possible in the present and future. Those who endorse the ‘history’ perspective are not only interested in individual heroic achievements, but also in what did not work out, or was lost in the historical development of ideas and techniques. They consider not only mathematical aspects, but also social and cultural contexts in which mathematics is situated. Those who endorse the ‘heritage’ perspective, in contrast, pursue their work by considering the present as if it were ‘photocopied onto the past,’ that is, as if the meanings and uses of mathematical objects were the same in the past as they are today. The heritage perspective may inhibit the opportunity to experience commognitive conflicts, that is, to experience how the metarules, endorsed narratives and routines governing mathematics have been changing over time.

The work on the part of the teachers to incorporate history of mathematics in their teaching is moreover a component of the “something else” (Ball et al., 2008). Those authors with the aim of describing this something else, introduced the category of Horizon Content Knowledge (HCK), defined as that which makes teaching more skillful. This includes the mathematical content that lies ahead, interpreted in the mathematical knowledge for teaching (MKT) context as “later grades.” But it also includes knowledge of what lies behind, and that “behind” also means orienting instruction to the discipline and making judgements about what is mathematically important.

In an attempt to extend and clarify this definition of Horizon Content Knowledge, Jakobsen et al. (2012) proposed a more practice-based definition:

*Horizon Content Knowledge (HCK) is an orientation to and familiarity with the discipline (or disciplines) that contribute to the teaching of the school subject at hand, providing teachers with a sense of how the content being taught is situated in and connected to the broader disciplinary territory. HCK includes explicit knowledge of the ways of and tools for knowing in the discipline, the kinds of knowledge and their warrants, and where the ideas come from and how “truth” or validity is established. HCK also includes awareness of core disciplinary orientations and values, and of major structures of the discipline (p. 4642).*

Regarding “where the ideas come from,” research indicates that knowledge of the history of mathematics may play a key role in developing teachers’ horizon content knowledge (Smestad et al., 2014). In understanding how this horizon content knowledge could emerge and evolve, we take a genetic approach that helps us to understand that history of mathematics is a scientific field which explains the journey of mathematical knowledge and the people who formed this knowledge throughout civilizations (Baki, 2014). This means that we consider how the milestones and obstacles that have emerged during more than 30 years of research on the history of mathematics and the history of mathematics education could highlight the evolution of teachers’ horizon content knowledge.

A review of the literature on the history of mathematics education leads us to identify three different periods in the research about the history of mathematics and its implications for teaching. Each period can be characterized by the ways that they articulate and pursue the following questions: why is history appropriated, and which history is appropriated, to be used for educational purposes; how is history used in teaching mathematics; and, how can history influence mathematical learning?

We consider the first period was initiated with the research question presented by Barbin (1997) on “*why history and which history is appropriated to be used for educational purposes?*.” It is a question that has been extensively discussed from several points of view, especially in relation to the appropriateness and pertinence of original historical sources in mathematics education. It has been analyzed mostly on the basis of both a priori theoretical and epistemological arguments, and of empirical research (Clark et al., 2019).

According to the literature, there is a more or less general consensus that the history of mathematics can have distinct roles or functions, mutually complementing and supplementing each other (Clark et al., 2019):

- *A replacement role.* This is the possibility offered by history to approach mathematics differently from the way it is often presented; that is, not only as final results, but also as mental processes that may lead to them; hence to perceive mathematics both as a collection of well-defined and deductively organized results, and as a vivid intellectual activity. For those teachers anchored in the perspective of an intelligible heritage of mathematics concepts, the question of “*how did we get this concept?*” could help them to better develop their horizon content knowledge, using history in a replacement role, and integrating “activity-based teaching.” Through this proposal, it can be demonstrated and dramatized that there were different conceptions of mathematical notions in different historical periods.
- *A reorientation role.* Considering a mathematical subject in historical perspective, that is, not in relation to our present knowledge and understanding, but in its historical, social, political, etc., context, as and when it was originally conceived, formulated and applied, Barbin (2006, 2012) reminds us that the history of mathematics has the virtue to astonish. The learner and, in consequence, the teacher, engage in a process where they are forced to reclaim mathematical



meaning (Janke et al., 2000). Teachers' reflection on their preconceptions about the concept on hand that they are studying and what knowledge, procedures and/or motivation are informing the original source would, this proposal suggests, affect teacher's epistemological knowledge about mathematics and mathematics teaching, and enlarge their horizon content knowledge.

- A *cultural understanding*. Integrating the history of mathematics can be an invitation to place the development of mathematics in the scientific and technological context of a particular time, and in the history of ideas and societies, and also to consider the history of teaching mathematics from perspectives that lie outside the established disciplinary subject boundaries (Janke et al., 2000). Mathematics in this proposal is appreciated as a cultural human endeavor: mathematics evolves under the influence of factors intrinsic and extrinsic to it, and forms part of local cultures. The evolution of teachers' horizon content knowledge that emerge from a cultural understanding of the history of mathematics should induce reflection on the factors that influence the understanding of this concept, how a local culture (it can be read from an ethnographic point of view) understands this concept, and therefore, how this concept should accordingly be taught. This cultural understanding demands also that all educators interrogate how these inherit concepts of science, knowledge and truth have come to be assumed rather than questioned. Part 3 of this book extends this idea through arguing that history of mathematics is also the history of mathematics education in this respect, since what has been taught and how that has been taught matters deeply for what we assume to be "the mathematics" and "how to teach mathematics", today and in the future.

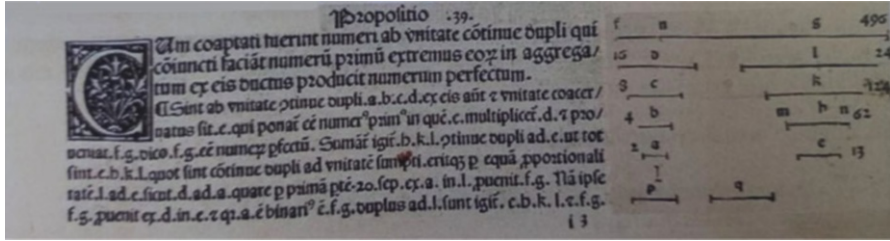
Janke et al. (2000) point out the value of primary sources of historical texts when history takes an orientation role. For these authors, the incorporation of primary sources in teaching mathematics is not good or bad in itself. In order to establish its goodness, it is necessary to have clarified the aims, the target population, the kind of source that might be suitable and the didactical methodology necessary to support its incorporation. Reading primary (original) historic texts may produce a cultural shock if the text is not read uniquely from the point of view of our current knowledge and understanding. Reading historical texts in class introduces history in an explicit way, and presupposes that the teachers have a sense of history, and further, that they are able to handle the mathematics involved in the historical artifact. In this case, the historic content knowledge of how the content to be taught is situated is a prerequisite for the teachers, but also, a tool for clarifying and extending what is found in secondary material, in order for the teacher and students to uncover what is not usually found there, to discern general trends in the history of a topic, to put in perspective some of the interpretations, and to value judgements or even misrepresentations found in the literature. Despite their potential, original sources have to be chosen with great care depending on the educational level in question in order to make sure that the students have a realistic chance of actually working with them (Jankvist, 2009). Meanwhile, when using secondary sources, the students are exposed to a given historian's presentation and, possibly, interpretation of history,

and teachers should make their choices based on this (Furinghetti, 2007). Tzanakis and Arcavi (2000) list some examples of secondary sources and the ways of using them to teach mathematics: historical snippets (life stories, works, pictures, etc.), research projects based on historical texts, worksheets, historical packages, errors, alternative concepts, historical problems, mechanical tools, experimental mathematics activities, games, films and other visual components, trips to historical places, the Internet. An extensive discussion on the issue of how teachers deal or have dealt in the past 20, 30 years in integrating technology in the teaching of mathematics is included in Part 2 of this book. This is referred, between others, to the importance of student-centered teaching and the role of developing materials in rich learning environments and the change in the dialectic media-message due to the development of digital technology brings out a new teaching paradigm which changes the relationship to teaching.

The reflection on the uses of primary and secondary historical sources for teaching mathematics has not only presented a contextualized answer to the questions of ‘why history’ and ‘which history’ is appropriated to be used for educational purposes, but has also initiated a debate about ‘how to use history’ in mathematics education. In this second period of research, which continued to be pursuing the questions of why to use history to teach mathematics, we can find papers that aimed to answer *how* we can use history to teach mathematics. This question, which has guided interesting research in the field of history of mathematics in teaching mathematics, could become a key issue for teachers’ reflection as they broaden their horizontal content knowledge and recognise the historical tools for knowing the mathematics.

Jankvist (2009) proposes three arguments referring to history as a tool: a motivation factor, a cognitive tool, and evolutionary arguments. As a motivation factor for students in their learning and study of mathematics, history can help to sustain the students’ interest and excitement in the subject, or it can provide a more human face of mathematics. Bakker and Gravemeijer (2006) suggest presenting pieces of the mathematical development over which past mathematicians have stumbled because these could also be troublesome for today’s students of mathematics; students may derive comfort from the study of such episodes in history, since the same mathematical concept that they themselves are now having trouble grasping actually took great mathematicians hundreds of years to shape into its final form, if such a form even exists (Bakker & Gravemeijer, 2006). A special use of history as a cognitive tool has been explained at the beginning of this introduction of the notion of epistemological obstacle introduced by Brousseau (1997) and his theory of didactical situations. The evolutionary arguments based on the perspective of phylogenetic evolution can be translated in the recapitulation argument presented above in this introduction, and can be formulated as: *To really learn and master mathematics, one mind must go through the same stages that mathematics has gone through during its evolution.* For Jankvist (2009), the recapitulation argument not only applies to mathematics as a whole, but also to single mathematical concepts and theories.

In order to exemplify how these three arguments for referring to history as a tool can converge when analyzing the evolution of a concept or the creation of a new



**Fig. 1** Proposition IX.36 Euclid’s Elements about perfect numbers, in the Ratdolt edition (Euclid (s.f))

theory, we present an example related to the definition, calculus and the proof of the existence of perfect numbers. The example starts from the study of definition 22 of book VII of the “Elements of Euclid” (Euclid, s. f), which says: “*a perfect number is that which is equal to the sum of its own parts*” and of proposition IX.36 which says: “if several numbers, starting with the unit, are in duplicate proportion and the set of all is a prime number, the product of this set by the last one is a perfect number”. (Fig. 1)

This proposition is an arithmetical prescription that allows one to easily calculate the first perfect numbers using current technological means; however, the first Pythagoreans only knew the perfect numbers 6 and 8. Nicomano of Gerasa presents the first four perfect numbers 6, 28, 496 and 8128 in his “Introduction to Arithmetic,” making the observation that they end in 6 and 8, which is elaborated by Jambolico, who adds that the perfect numbers end alternatively in 6 and 8 (uncertain from the fifth on, although it is true that those known so far end in 6 or 8). In addition, Jambolico believed that there is a perfect number in each of the intervals 1–10, 10–100, 100–1000, etc., which is false from the fifth interval onwards. These errors, collected by Boertius (Arithmetica 1.20), remained throughout the Middle Ages, which is understandable because of the manifest deficiencies of the precariousness of the numbering systems used, which did not facilitate the handling of very large and rapidly growing numbers. The proposition enunciated by Euclid warns of the importance in the investigation of perfect numbers of numbers of the form  $M(n) = 2^n - 1$ , called Mersenne Numbers, especially when they are prime (which requires that  $n$  also be prime), then called Mersenne Perfect Primes (Gonzalez Urbaneja, 2017).

Mersenne published *Cogiata Physica-Mathematica* in 1664, including the next image, in which he described the errors committed by Pedro Bungo, and stated that  $2^n - 1$  is prime for the following values of  $p$ : 2, 3, 5, 7, 13, 19, 31, 67, 127, 257, and composite for all other values of  $n < 257$  (Mersenni, 1644) (Fig. 2).

Even the historic analysis could continue with the study of Euler’s attempts to enlarge the list of perfect numbers in 1739. Euler studied perfect numbers for  $n = 41$  and  $n = 47$ , but in 1750 was able to recognize his error and prove the Euclid-Euler Theorem: *an even number is perfect if and only if it has the form  $2^p - 1(2^p - 1)$ , where  $2^p - 1$  is a prime number*. Even more important than the proof of the theorem

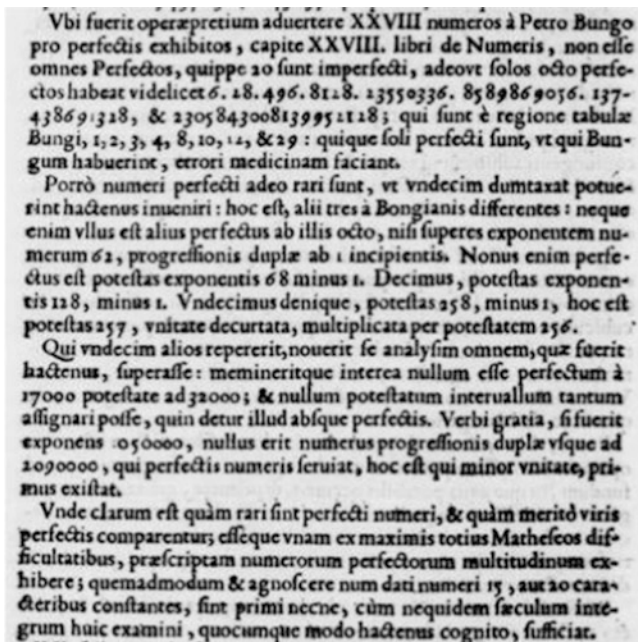


Fig. 2 Perfect numbers. Preface XIX. Mersenne (1664)

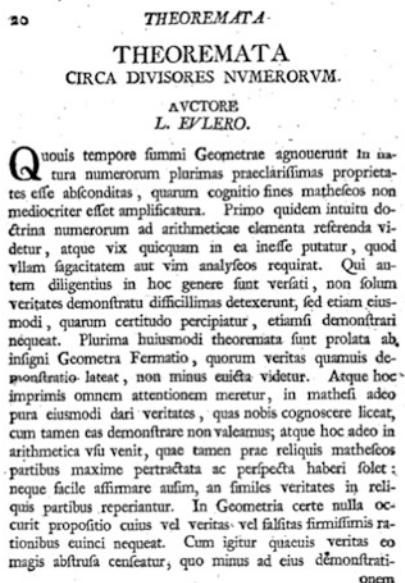
itself are the words that Euler worked on in the preface of this demonstration, recognizing the importance of the emergent new field of mathematical knowledge, the Theory of Numbers. He wrote (Fig. 3):

*At any time, the greatest mathematicians have recognized in nature many of the most important and most hidden properties, of which the limits of astrology will not be greatly enlarged when they know it. At first glance, the doctrine of numbers seems to be related to the elements of arithmetic, and scarcely anything in it is thought to be ineffable, since it requires no flair or force of analysis. But those who have been more diligently turned in this class, have not only detected the most controversial truths by demonstration, but also the ways in which it can be perceived with certainty, even if it cannot be demonstrated. Much of this theorem has been produced by the incredible geometry of Fermat, whose truth, although the demonstration is hidden, seems to have been proved no less.*

*And this deserves special attention, that there are so pure truths of this kind in mathematics, which it is lawful for us to know, although we are not able to demonstrate them; and this comes so much in arithmeticalism, in which, however, it tends to be considered more thoroughly and well-seen than the other mathematicians, nor is it easy to say whether similar truths are found in the other parts (Euler, 1747)*

Despite the astonishment provoked by the reading of these excerpts of primary sources—in the words of Janke et al. (2000)—the excerpts are useful for presenting the different manners in which the history of mathematics may be used in the teaching and learning of mathematics. Jankvist (2009) presents three categories of approaches to introduce history: the illumination approaches, the module approaches and the history-based approaches. In the illumination approaches, the teaching and

**Fig. 3** Prologue of the Euler Journal article on Theory of Numbers (Euler, 1747)



learning of mathematics is supplemented by historical information, for example, ‘isolated factual information’ or ‘historical snippets,’ which may cover famous works and events, time charts, biographies, famous problems and questions. With the previous example on hand, these might be the names of those who have worked with perfect numbers or its definition in Euclid’s *Elements*.

The module approaches are instructional units devoted to history based on cases. These might simply be collections of materials narrowly focused on a small topic, for example the two excerpts in the example of perfect numbers, Euclid’s *element book* and preface XIX of the Mercenne book. In the middle scale of the module approaches, modules of perhaps 10–20 periods could help to study, for example the history of the Theory of Numbers through an Internet biographical analysis. Finally, in these module approaches, teachers can develop a course relying on original or secondary sources, for example, on the History of the Theory of Numbers.

Finally, Jankvist (2009) proposes the category directly inspired by or based on the development and history of mathematics. We understand this category as foregrounding the evolutionary nature of mathematics, both in context and form (notation, terminology, computational methods, meta-mathematical concepts, modes of expression and representation), including as well extrinsic characteristics of the mathematical activity. The reading of the Prologue of the Euler Journal article on Theory of Numbers could be a great example of the evolutionary nature of mathematics (Clark et al., 2019) from the point of view of Janke’s hermeneutic approach (Janke et al., 2000). In this approach, mathematics learners are conceived as interpreters, so that the reading of historical texts becomes a way of exploring one’s mathematical identity (Fried, 2018).

The extension in the described second period of research about why, which and how history could be used to teach mathematics segues into what can be recognized as yet a third period. This third period, mostly evident in research from the year 2000 and later, seeks answers to the question: how can history influence the mathematical learning of students? In this mostly recent research literature, the benefits of using history in classes are describe in five potential ways: (i) it may help students understand that mathematics is a human activity and product; (ii) it may help to increase a student's motivation and facilitate a positive attitude towards learning; (iii) it may develop students' perspectives on the nature of mathematics and mathematical activities, as well as teachers' instructional repertoire; (iv) it may support increased understanding of mathematical concepts, problems and solutions; and (v) it may have positive effects on students' cognitive and affective development (Bütüner, 2018).

Despite such potential for the inclusion of history, counterarguments and objections of a didactical and a practical nature may emerge when teachers are asked to integrate history into their teaching (Clark et al., 2019). Nevertheless, as stated by NCTM (1989), students should have numerous and varied experiences related to the cultural, historical, and scientific evolution of mathematics so that they can appreciate the role of mathematics in society, and the disciplines it serves. This document identifies three contexts where the experiences should emerge: culture, history and science. Niss and Højgaard (2011) describe three similar contexts –nature, society and culture- as a competence-driven experience for developing students' awareness about three further dimensions of mathematics: history, applications and philosophy (Jankvist, 2013). The claim is that teaching activities should be designed to develop students' awareness of history, applications and philosophy when learning mathematics. This is still an open research question, which seems boundless; yet, when considering educational standards set by different countries around the globe, and the persistent teacher lament that “*there is not enough time to teach history of mathematics*” (Clark, 2020), we must also understand the limits of our imagination when proposing possibilities.

To sum up, the theoretical framework presented to answer the question, ‘why, which, how to use history in teaching mathematics’ has provided information about the approaches, dimensions, roles and tools that could help teachers to initiate and to deepen their horizon content knowledge. The framework further establishes a possible evolution in the acquisition of this horizon content knowledge through the classification of Fried (2007) about the use of the history of mathematics. In the first place, we find those teachers who persist in their commitment to modern mathematics and modern techniques, and who are at risk of being whiggish, i.e., ahistorical in their approach (Fried, 2007). The second category of teachers, in the words of Fried (2007), trivialize the use of history in their teaching by including anecdotes, mathematicians' biographies, historical problems, or photos of mathematicians. Fried (2001) uses the term “addition strategy” to describe this approach, in which the existing curriculum is unchanged, only expanded (in trivial ways). In contrast with the first group of teachers, with this approach, learners are encouraged to think of mathematics as an evolving body of knowledge rather than as a well-

defined entity composed of irrefutable and eternal truths (Barbin et al., 2000). Finally, according to Fried (2007), the third type of teacher takes a genuinely historical approach to the history of mathematics.

Although this framework provides a new pathway for teachers' development of their horizontal content knowledge, "*it still requires further empirical studies to confirm its educational value in the future*" (Clark, 2020, pp. 24), examples of which are presented in the four chapters of the first part of this book.

In Chap. 1, Guillemette presents a paper aimed at the exploration of (and the engagement with) ancient ways of doing mathematics, based on the cultural aspect of mathematical activity and the social and cultural perspective of teaching mathematics. He presents an investigation regarding the theoretical elements from a hermeneutic approach, the *dépaysement* (*reorientation role*) and the *inaugural understandings* that bring two interrelated forms of reflections on how students learn using history: (a) students learn something about their own mathematics by experiencing and "reflecting on the contrast between modern concepts and their historical counterparts;" (b) students' abilities, deepening the mathematical understanding on both levels, doing mathematics and thinking about mathematics. The potential of these reflections is exemplified with the work of Ptolomey presenting: the biographical notes of this author, the reference to the prologue of the book *Mathematike Syntaxis*, and the modern mathematics notation and calculations that are needed to relate the arcs and the lengths of the chords when reasoning with circles presented in the primary source of Ptolomey. From the hermeneutic perspective, he describes the *inaugural understandings* of trigonometry of the circle, instead of the modern mathematics understanding in the triangle. Finally, he discusses on the didactical and pedagogical potential that a situated cognition could have for surpassing the difficulty of the transition from trigonometry of the triangle to the trigonometry of the circle, the construction of the table of the relationship between the arc and the chord by the students, the understanding of the concepts of sine, cosine and tangent of 0 and 90 degrees, and working with a different "definition" of these ratios.

Menezes, in Chap. 2, presents a module approach in designing a formative experience that links History, Mathematics, Philosophy-Sociology and the Didactics of Mathematics. A qualitative and interpretive methodology has been applied, aiming to understand how mathematical tasks, which bear upon historical context, contributed to student learning in terms of understanding: the nature of mathematics; the historical development of mathematical knowledge and the processes by which it is developed; and mathematical concepts and their modes of representations. He proposes a module consisting of working with the history of mathematics in two phases. The first phase consists of reading and discussing secondary sources of texts about the evolution of mathematical knowledge; the second phase focuses on solving, discussing and reflecting on mathematical tasks corresponding to problems posed/solved by different civilizations. The author concludes that the students become aware of the nature of mathematical knowledge, and indeed that they understand the role that problem solving has played in the historical development and construction of mathematical concepts, in addition to the development of the

students' affective dimension and their recognition of the social relevance of mathematics.

Chapter 3, written by Romero, presents an illumination-historic approach to modeling and applications in order to enrich secondary students' capacities in the field of conjectures, proofs and refutations. Three case studies are presented in the text. The first requires that students reflect on how square roots are mathematical expressions that arose when posing various geometric problems, included in the Ahmes Papyrus dated to 1650 BC. They use modern mathematical techniques to solve these large square roots. The second seeks to motivate students and to help them understand that mathematics is a human activity and product through interaction with primary and secondary sources such as bibliographies; students also study the correspondence between Euler and Golbach related to Goldbach's conjecture. The chapter further describes the impact of presenting an excerpt of a film to illuminate and motivate students' understanding of the Vessels Problem studied by Niccolo Fontana Tartaglia in the sixteenth century.

Finally, in the fourth chapter, Madrid, León-Mantero and Maz-Machado, presents an historic-based approach and exemplifies the dichotomy of history/heritage when researching the resolution of second degree equations. They present the most common and current resolution of second degree equations in Spanish textbooks, and research about the particular heritage question of "how did they get there?" as well as the general question of "how algebraic thought was introduced in Spain?". In order to answer these two questions they present an historic introduction to the solution of second degree equations and an exploratory, descriptive and *ex post facto* research summary of what is described in the books of the sixteenth, seventeenth century and eighteenth century. They discuss the evolution presented in the resolution of quadratic equations in Spanish mathematics books related to the notation, the computational methods, the number of roots and the consideration of negative roots. They also highlight the epistemological obstacles that emerged during the evolution of the resolution of the second-degree equations: the impossibility of negative roots, and the null solution for quadratic equations of the form  $ax^2 = bx$  or  $ax^2 = bx^2$ . And, they conclude with a discussion about the reorientation role of history concerning its didactical and pedagogical potential that the study of these texts could have, for example, to compare old and modern methods in order to value modern ones, or to understand the evolution of the algebraic thinking and past obstacles and mistakes looking for an historic parallelism.

Summing up, the reading of these four chapters of part one is about breaking the chronological boundaries inherited from the ancient, medieval, classic and modern mathematics, and to think about the place of the History of Mathematics to enlarge teachers' horizon content knowledge. As we have described in the first paragraph of this introduction, using history has been a strategy for teaching mathematics since the beginning of the history of C.I.E.A.E.M. The initial aims for using history were, first, to improve teachers' own mathematical education, and also to provide a different pedagogical orientation for classroom mathematics. Currently, it is an aim to revisit the History of Mathematics by highlighting the contribution of different cultures to the evolution of Mathematics.



## References

- Atiyah, M. (2014). *Collected works. Volume 7: 2002–2013*. Oxford University Press.
- Baki, A. (2014). *Matematik tarihi ve felsefesi*. Pegem Akademi Yayinıcılık.
- Bakker, A., & Gravemeijer, K. (2006). An historical phenomenology of mean and median. *Educational Studies in Mathematics*, 62, 149–168.
- Ball, D. L., Thames, M. H., & Phelps, G. (2008). Content knowledge for teaching: What makes it special? *Journal of Teacher Education*, 59(5), 389–407.
- Barbin, E. (1997). Historie et enseignement des mathématiques: pourquoi? Comment? (History and mathematics teaching: why? how?). *Bulletin de l'AMQ (Association Mathématique du Québec)*, XXXVIII(1), 20–25.
- Barbin, E. (2006). Apport de l'histoire des mathématiques et de l'histoire des sciences dans l'enseignement [History of mathematics and history of sciences' contributions in the teaching]. *Tréma*, 26(1), 20–28.
- Barbin, E. (2012). L'histoire des mathématiques dans la formation: Une perspective historique (1975–2010) [History of mathematics in the teaching: A historical perspective (1975–2010)]. In J. L. Dorier & S. Coutat (Eds.), *Acte du congrès de l'EMF 2012* (pp. 546–554). University of Geneva.
- Barbin, E., Bagni, G., Grugnetti, L., & Krofenher, M. (2000). Integrating history: Research perspective. In J. Fauvel & J. Maanen (Eds.), *History in mathematics education – The ICMI study* (pp. 63–90). Kluwer.
- Boero, P., & Guala, E. (2008). Development of mathematical knowledge and beliefs of teachers: The role of cultural analysis of the content to be taught. In P. Sullivan & T. Wood (Eds.), *The international handbook of mathematics teacher education, Volume I: Knowledge and beliefs in mathematics teaching and teaching development* (pp. 223–244). Sense.
- Brousseau, G. (1997). Theory of didactical situations in mathematics, ed & N tr Balacheff et al. : Kluwer.
- Bütüner, S. O. (2018). Secondary school mathematics Teachers' knowledge levels and use of history of mathematics. *Journal of Education and Training Studies*, 6(1), 9–20. <https://doi.org/10.11114/jets.v6i1.2722>
- Clark, K. (2020). History and pedagogy of mathematics in mathematics education: History of the field, the potential of current examples, and directions for the future. In *Eleventh congress of the European Society for Research in mathematics education, Utrecht University, Feb 2019*, (hal-02436281). Utrecht, Netherlands.
- Clark, K., Kjeldsen, T. H., Schorcht, S., & Tzanakis, C. (2019). History of mathematics in mathematics education – an overview. *Mathematica didactica*, 42, 1–26.
- Euclid. (s.f.). *Euclid's "Elements"*. Venice: Erhard Ratdolt, 1482-05-25.
- Euler, L. (1747). Theoremata circa divisores numerorum. *Novi Commentarii academiae scientiarum Petropolitanae*, 1, 20–48.

- Farmaki, V., & Paschos, T. (2007). Employing genetic ‘moments’ in the history of mathematics in classroom activities. *Educational Studies in Mathematics*, 66, 83–106.
- Fried, M. N. (2007). Didactics and history of mathematics: Knowledge and self-knowledge. *Educational Studies in Mathematics*, 66, 203–223. <https://doi.org/10.1007/s10649-006-9025-5>
- Fried, M. N. (2018). History of mathematics, mathematics education, and the Liberal arts. In G. Kaiser et al. (Eds.), *Invited lectures from the 13th international congress on mathematical education (ICME-13 Monographs)*. Springer. [https://doi.org/10.1007/978-3-319-72170-5\\_6](https://doi.org/10.1007/978-3-319-72170-5_6)
- Fried, N. M. (2001). Can mathematics education and history of mathematics coexist? *Science and Education*, 10, 391–408. <https://doi.org/10.1023/A:1011205014608>
- Furinghetti, F. (2007). Teachers education through the history of mathematics. *Educational Studies in Mathematics*, 66, 131–143. Special issue on the history of mathematics in mathematics education.
- Furinghetti, F., & Menghini, M. (2014). The role of concrete materials in Emma Castelnuovo’s view of mathematics teaching. *Educational Studies in Mathematics*, 87(1), 1–6. <https://doi.org/10.1007/s10649-014-9569-8>
- Gonzalez Urbaneja, P. M. (2017). *Los elementos de Euclides. Biblia de la Geometría griega*. Servicio de Publicaciones de la FESPM.
- Grattan-Guinness, I. (2004). History or heritage? An important distinction in mathematics and for mathematics education. *The American Mathematical Monthly*, 111(1), 1–12.
- Harper, E. (1987). Ghost or Diophanthus. *Educational Studies of Mathematics*, 18, 75–90.
- Jahnke, H. N., Jankvist, U. T., & Kjeldsen, T. H. (2022). Three past mathematicians’ views on history in mathematics teaching and learning: Pointcaré, Klein, and Freudenthal. *ZDM-Mathematics Education*, 54, 1421–1433. <https://doi.org/10.1007/s11858-022-01376-0>
- Jakobsen, A., Thames, M. H., Ribeiro, C. M., & Delaney, S. (2012). Using practice to define and distinguish horizon content knowledge. In *Pre proceedings of ICME12, the 12th international congress on mathematics education* (pp. 4635–4677). ICMI.
- Janke, H. N., et al. (2000). The use of original sources in mathematics classroom. In J. Fauvel & J. van Mannen (Eds.), *History in mathematics education: The ICMI study* (pp. 291–328). Kluwer.
- Jankvist, U. T. (2009). A categorization of the “whys” and “hows” of using history in mathematics education. *Educational Studies in Mathematics*, 71, 235–261. <https://doi.org/10.1007/s10649-008-9174-9>
- Jankvist, U. T. (2013). History, applications, and philosophy in mathematics education: HAPh-A use of primary sources. *Science and Education*, 22, 635–656. <https://doi.org/10.1007/s11191-012-9470-8>
- Mazzocchi, F. (2022). Diving deeper into the concept of “cultural heritage” and its relationship with epistemic diversity. *Social Epistemology*, 36(3), 393–406. <https://doi.org/10.1080/02691728.2021.2023682>

- Mersenni, F. M. (1644). *Cogitata physico-matematica: In quibus tam naturae quàm artis effectus admirandi certissimis demonstrationibus explicantur*. Sumptibus Antonij Bertier, viâ Iacobæâ.
- National Council of Teachers of Mathematics (NCTM). (1989). *Curriculum and evaluation standards for school mathematics*. Author.
- Niss, M., & Højgaard, T. (Eds.). (2011). *Competencies and mathematical learning—ideas and inspiration for the development of mathematics teaching and learning in Denmark*. English Edition, October 2011. IMFUFA tekst no. 485. Roskilde: Roskilde University (published in Danish in 2002).
- Sfard, A. (1995). The development of algebra: Confronting historical and psychological perspectives. *Journal of Mathematical Behaviour*, 14, 15–39.
- Smestad, B., Jankvist, U. T., & Clark, K. (2014). Teachers' mathematical knowledge for teaching in relation to the inclusion of history of mathematics in teaching. *Nordic Studies in Mathematics Education*, 19(3–4), 169–183.
- Thomaidis, Y., & Tzanakis, C. (2007). The notion of historical 'parallelism' revisited: Historical evolution and students' conceptions of the order relation on the number line. *Educational Studies in Mathematics*, 66, 165–183. Special issue on the history of mathematics in mathematics education.
- Tzanakis, C., & Arcavi, A. (2000). Integrating history of mathematics in the classroom: An analytic survey. In J. Fauvel, & J. van Maanen (Eds.), *History in mathematics education* (pp. 201-240, Chapter 7). The ICMI Study. Dordrecht: Kluwer Academic Publishers.
- Zorbala, K., & Tzanakis, C. (2004). The concept of the plane in geometry: Elements of the historical evolution inherent in modern views. *Mediterranean Journal of Research in Mathematics Education*, 3(1–2), 37–62. Special double issue on the role of the history of mathematics in mathematics education (proceedings from TSG 17 at ICME10).

# Chapter 1

## The Exploration of Inaugural Understandings in the History of Mathematics and Its Potential for Didactic and Pedagogical Reflection



David Guillemette

**Abstract** This chapter concerns the exploration of the history of mathematics with emphasis on its potential for secondary school teachers' education. From an example coming from the history of mathematics (Ptolemy's *Almagest*), we emphasize how history can provide *inaugural understandings* in mathematics that could foster didactic and pedagogical reflections of pre-service and in-service teachers. Firstly, we present the example coming from the history of mathematics in the Greco-Roman world, with the concern to situate the mathematical works in its intellectual ambiance. From a hermeneutico-phenomenological stance, we describe different ways-of-being and ways-of-doing mathematics appearing from the example that underpins the *inaugural understandings* that can be found in Ptolemy's work. This leads to some element of a didactic and pedagogical reflection around teaching and learning trigonometry. Finally, we open the discussion about how the exploration of these *inaugural understandings* can be an opportunity to discuss and to reflect on major theorization and conceptualization in mathematics education such as embodied or situated cognition or historico-cultural perspectives.

**Keywords** History of mathematics · Teachers' education · Mathematics education · Inaugural understandings · Hermeneutico-phenomenological perspective

### Introduction

There is a close relationship between the history of mathematics and mathematics education that has repeatedly been developed and implemented. Especially within research in mathematics education, this relationship has been explored very early,

---

D. Guillemette (✉)

Département de mathématiques, Université du Québec à Montréal (UQAM), Montreal, QC, Canada

e-mail: [guillemette.david@uqam.ca](mailto:guillemette.david@uqam.ca)

particularly by the International Study Group on the Relations between the History and Pedagogy of Mathematics (HPM Study Group). Affiliated with the International Commission on Mathematical Instruction (ICMI), the HPM Study Group aims to investigate different conceptions and views of mathematics. Its members study different eras, mathematicians, regional and national mathematical schools, mathematical textbooks, and many other topics from the history of mathematics. They seek to connect the history of mathematics as a discipline, its roles in education, and the roles that it continues to have in developing mathematical instruction and the curricula around the globe (see International Mathematical Union, 2021).<sup>1</sup>

Let's mention that fifty years ago, in 1972, a working group on the "History and Pedagogy of Mathematics" was organized by Phillip. S. Jones and Leo Rogers during the second International Congress on Mathematics Education (ICME 2). This working group leads to the creation of the International Study Group on the relations between the History and Pedagogy of Mathematics (afterwards known as the HPM Group) in 1976.

Indeed, the interest in the history and epistemology of mathematics became stronger and more important and organize in the 1960s and 1970s in response to the "New Math" reform (Barbin, 2012). This led to fifty years of research at an international level, and countless worldwide studies on the relationship between the history of mathematics and mathematics education. Research has shown in many ways and circumstances important support and insights that the history of mathematics can bring to didactic and pedagogical reflection and to the development of teaching practices (see Barbin et al., 2020; Clark et al., 2016; Fauvel & van Maanen, 2002). Numerous arguments supporting the presence of history in the teaching and learning of mathematics have been advanced, as well as many ways of putting these elements into practice (reading of historical texts, snippets, historical problems, modular approach, genetic approach, etc.).

The 2000 CIEAEM manifesto is marked with strong emphasize on the cultural and historical dimension of mathematics and of mathematics education (see CIEAEM, 2000). These dimensions are clearly embedded in a strong humanistic ambience and anchoring. More concretely, the very active workshop around Cultures in mathematics has welcome many conferences and discussions on the introduction and the potential of the history of mathematics in mathematics education. The working group has developed numerous insights on a more critical based fundament in this sense, especially on how mathematical abstractions and formalizations applied to social reality create formal systems and hierarchies, what kind of research in mathematics education may contribute to creating a new view of mathematics practice, what must be done to appropriately examine the impact of a

---

<sup>1</sup>Let's mention that, already in the second half of the nineteenth century, mathematicians like Felix Klein and Augustus De Morgan, and historians like Paul Tannery and Gino Loria, were showing an active interest in the role of the history of mathematics in education already (see Barbin et al., 2020). Furthermore, we can go back even to Proclus to whom the history of mathematics could help pointing out and discussing the first discovers of a given result, having in mind educational goals (see Fried, 2014).

transfer of ideas and experiences for other cultures and establishing mathematics education as a discipline that serves to critique theory as well as to provide a contribution to practise.

Despite many developments in the field, and constant research activities in the last decades, some major issues are still discussed and are keenly experienced. For instance, the development of theoretical or conceptual frameworks appropriated to the field of research is still sorely lacking (Barbin et al., 2020; Clark et al., 2016; Fried et al., 2016). It seems necessary to envision and develop new concepts and perspectives for a more in-depth reflection on the foundations and applications of the history of mathematics in teaching and learning.

In this contribution, we focus on preservice teachers' education, with emphasis on the exploration of (and the engagement with) ancient ways of doing mathematics. We offer an investigation regarding theoretical elements and conceptualizations that allow us to think about these educational practices. In view of a precise objective for this article, we will clarify, in the next section, the need for such theoretical elements and conceptualizations.

## The Research Problem

For more than a decade now, research around the potential contribution of the history of mathematics to mathematics education has been restructuring. In the proceeding of the 2016 HPM Group meeting in Montpellier, France, Clark et al. (2016) published an important paper concerning recent developments in the field of research on the history of mathematics in mathematics education. The authors put forward some elements related to the needs and issues presently lived in the field. In their concluding remarks (p. 175), the authors mention issues that are currently central for the researchers: (1) to put emphasis on pre- and in-service teachers' education, (2) to design, make available and disseminate a variety of didactic source material, (3) to systematically and carefully perform applied empirical research in order to examine in detail and convincingly evaluate the effectiveness of HPM perspective, and (4) to acquire a deeper understanding of theoretical ideas put forward in the HPM domain to carefully develop them into coherent theoretical frameworks and methodological schemes.

These issues can be linked to those more recently raised by Barbin et al. (2020) in the chapter *History of mathematics in education* in the *Encyclopedia of mathematics education*. In the section Current concerns and emergent questions in the field, the authors mention the need for (1) common ground between the history of mathematics and mathematics education, (2) effective theoretical and conceptual frameworks, (3) more in-depth empirical studies, and (4) a more refined reflection around the interdisciplinary role of history.

We can recognize a convergent and recurrent point: the need for the development of theoretical positioning and conceptual basis in the field. Putting emphasis on

preservice and in-service teachers' education, we will discuss theoretically about the potential of the encounter with ancient ways of doing mathematics.

Within the HPM Group literature, it is now quite well established that, when students engage with the history of mathematics, especially in the context of the readings of primary historical sources, it may provide "unfamiliarity". In a sense, the history of mathematics puts the learners on foreign ground, this phenomenon is often referred to as *dépaysement* (Barbin, 1997; Pengelley, 2011). Studies show that the educationally rewarding aspects of such *dépaysement* are that students become more inclined to keep an open mind in relation to mathematical concepts (Furinghetti et al., 2006; Guillemette, 2017), and that it may lead to "meta-level" learning (Kjeldsen & Blomhøj, 2012).

From a hermeneutic approach, reading a historical text in mathematics, and the associated *dépaysement*, bring two interrelated forms of reflections in the context of teachers' training. Firstly, students learn something about their own mathematics by experiencing and "reflecting on the contrast between modern concepts and their historical counterparts" (Fried et al., 2016, p. 218). This idea goes either direction, so that students deepen both their understanding of history and their own perspective. Secondly, the aim is to think about the mathematicians in their context. This poses completely new demands on students' abilities, deepening the mathematical understanding on both levels: doing mathematics and thinking about mathematics. In particular, in the context of teachers' education, a feeling of participation or solidarity within mathematics can engage prospective teachers to a more attentive relation to their future pupils (Arcavi & Isoda, 2007; Guillemette, 2017).

As mentioned above, it is quite well established that the history of mathematics can provide ways of doing mathematics (and being in mathematics) that are very different from what is common nowadays. Engaging in such an exercise bears some similarities to the process of grasping what lies behind learners' thinking and actions. This does not mean that there may be parallels between the mathematics underlying primary sources and that of learners, but experiencing the process of understanding the mathematical approach of a primary source can be a sound preparation for learning to listen to them (Arcavi & Isoda, 2007; Guillemette, 2017).

This said, there is a need to think about more precisely, about these questions. In particular, on the potential of encountering historical elements and to conceptualize more about these potential reflections on the contrast between modern concepts and their historical counterparts (Barbin et al., 2020; Clark et al., 2016; Fried et al., 2016). It is particularly the case for teachers' education (Clark et al., 2016). Pengelley (2011) has collected different "potentialities" for teachers' education that have been put forward: "understanding essence, origin, and discovery, mathematics as a humanistic endeavour; participating in the process of doing mathematics through experiments, conjecture, proof, generalizations, publication and discussion; more profound technical comprehension from initial simplicity" (p. 3).

The reader will easily find some similar arguments in other works like those of Furinghetti et al. (2006) and Jahnke and his collaborators (Jahnke et al., 2002). This said, we could legitimately ask: Why understanding mathematics origin and discovery is important concretely for the pre- and in-service teachers? What are the

pedagogical and didactic rewards for such engagement with the history of mathematics? Which history has to be presented/explored? In what ways? What can be found within this “initial simplicity”? How does teachers’ education can concretely take advantage of it? On what educational foundations can we base these considerations? In this chapter, our objective is not to refute or to dispute these already mention potentialities for teachers’ education. Rather we would like to refine the argumentation by attempting to develop a particular theoretical positioning and, ultimately, to provide some articulated avenues for reflection and intervention.

In the next section, exemplified later with the exploration of the work of Ptolemy regarding trigonometry, we will present and detail a specific theoretical position and some conceptualizations aiming to think about the potential of the history of mathematics for teachers’ education.

## Inaugural Understandings in Mathematics

Hermeneutics was originally defined, as the art of interpreting a text. More broadly, it refers today to a general theory of interpretation (Grondin, 2011). The concern of the hermeneut is “to keep open a space of variations, to aim less at persuasion than to open the imagination, in order to highlight a community of interpretation” (Ricoeur, 1986, p. 152), a certain “membership structure” would say Gadamer (1991). The fact is that all understanding emerges against the background of concerns and questions linked to an interpretive tradition (Warnke, 1991). The hermeneutic approach seeks to describe this belonging.

Some empirical and theoretical studies in HPM literature are grounded in the hermeneutic perspective (e.g., Arcavi & Isoda, 2007; Glaubitz, 2011; Jahnke, 2014). Accounting for teachers’ education, this approach has brought two interrelated forms of reflections by the students confronted to the history of mathematics. First, there is the experience of “dissonance” or “alienation”, just like the feeling of being in a foreign country. At the point of what is called the “hermeneutic circle”,<sup>2</sup> the reader arrives at a satisfying result after a kind of saturation of meaning. This reflection goes in both directions, so that the students deepen both their understanding of history and of their own set of modern conceptualizations regarding mathematics and mathematical objects. Second, the task is now to think about the situation of the mathematicians living in the past. This task requires being able to argue from the assumptions of these persons, to use their symbols and methods. This poses quite new demands on the students’ abilities in their mathematical activities.

According to the hermeneutic perspective, a text consists in the merging of different horizons, the horizon of the reader and the horizon of the author. This

---

<sup>2</sup>A Gadamerian concept which refers to the process in which a hypothesis is put up related to what the student is confronted, tested against the source by confronting it with other parts of the text, modified, tested again and so on, and so on.



means, of courses, that different readers embedded in their different backgrounds arrive at different interpretations. The texts here are the problems and the things that students are confronted with. As mentioned above, from the hermeneutic perspective, there is an emerging process of reconciliation between past and present understandings, a process that we are looking to describe. A reconciliation that could make possible the creation of a filiation or the emphasize of a belonging to a community of interpretation. Indeed, as Jahnke put it: “This might cause a feeling of participation or solidarity” (Fried et al., 2016, p. 220), a feeling of being with the others in mathematics, in a community. Jahnke goes deeper by claiming that this feeling of participation or solidarity can engage prospective teachers to a more attentive relation to their future pupils.

Let’s not forget that the hermeneutic perspective has itself a history, and that this history is closely related to phenomenology, the philosophical tradition inaugurated by Husserl at the beginning of the twentieth century. Indeed, phenomenology, especially with the work of Heidegger and Gadamer has contributed to a renewal and a regain of interested regarding hermeneutics, which was at that time confined to the study of traditional religious texts (*exegesis*). Indeed, Heidegger envisaged to found, no longer a logic of meanings or a logic of values like Husserl, but a “radical logic of the origin” (Jollivet, 2009). If phenomenology claims at the same time to sift through its critique the conceptuality inherited from tradition, it is indeed to bring the fundamental concepts, which it itself makes use of their living source, namely to shed light on them, through a sort of genetics of meaning, in the direction of their original motives located in the concrete experience of life, culture and history. In other words, the Heideggerian (and later Gadamerian) revivals of phenomenology will radicalize the transcendent pole of intentionality to the point of liberating transcendence from all immanence. In short, there is a prioritization of the World over Subjectivity in the elucidation of the essences. Understanding therefore constitutes an “event”: each interpretive act is a meeting between what comes from us and what comes from the past. In this sense, there is a real “work of the history”: each event or each work is enriched by the new interpretations given to it. It is in the element of language, to which Gadamer’s hermeneutics for instance attaches fundamental importance, that this interpretive dialogue takes place.

Back to mathematics and to the history of mathematics in mathematics education, we could now try to think more precisely about the potential of the history of mathematics, and which kind of educational awards the study of it could bring. Indeed, the history of mathematics can reveal the origin of mathematical concepts or its chronological development, but, within the hermeneutic approach, it could rather reveal partially lost or occulted senses of mathematics concepts and notions, that is grounded more concretely in the experience of life and culture. These senses are what we call *inaugural understandings* in mathematics. In other words, the idea is that the educational potential of the history of mathematics in the context of teachers’ education could not reside in the account of a particular history *stricto sensu*, but in pedagogical and didactic reflections emerging from a hermeneutic type of exercise that could reveal these *inaugural understandings* in mathematics. Indeed, these *inaugural understandings* could foster meeting opportunities with ways to do and

to be radically different in mathematics. Within this encounter, the learners engage in a kind of dialogue, which surmounts the closedness and one sidedness of their particular meanings, and bring them in the search for a sort of reconciliation and reconstruction of meaning. These arguments can be linked to the need for prospective teachers to “unclog automatism” highlighted by Freudenthal (1983, p. 469), that is to say to unpack issues taken for granted in order to develop abilities to understand students’ conceptions and potential entailments. In short, there is a need for a more decentring position and effective listening of the classroom activities (see Ball, 1993).

In the next section, we will present and detail an example with the case of the exploration of the work of Ptolemy regarding trigonometry. It will allow us to illustrate more concretely our theoretical positioning and what *inaugural understanding* could mean.

## An Example with the Work of Ptolemy

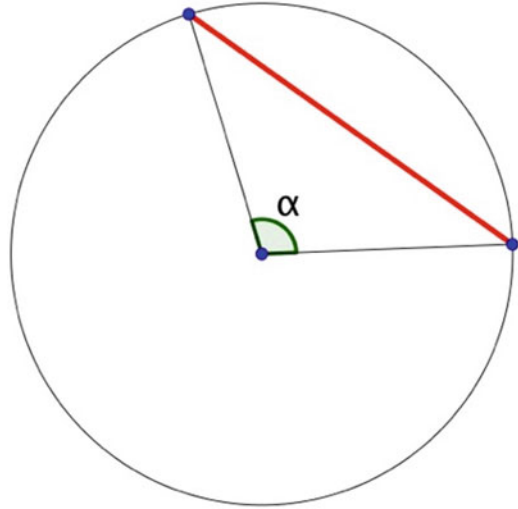
Claudius Ptolemy, an Alexandrian astronomer, and mathematician from the second century, wrote a famous treatise entitled *Μαθηματικὴ Σύνθεσις* (Mathematike Syntaxis) or The Mathematical Compilation, on the apparent motions of the stars and planets. This work soon became known as The Greatest Compilation and it established the model of a geocentric universe, a scientific schema that would be followed for the next thousand years. When Ptolemy’s work was adopted in the Islamic world, its title in Arabic was shortened to The Greatest, which when transliterated into Latin became Almagest (Swetz, 2013). The first complete Latin edition of the Almagest was published in the sixteenth century. Claudius Ptolemy has the same name as the monarchs of the great Greek dynasty who will reign over Egypt during the great Hellenistic and Greco-Roman period, which has led to some deviations, as he is sometimes represented through the age with a crown or other royal attributes. Even if his name is Roman (*Claudius*), he was an astronomer of Greek culture, installed in Alexandria, who built a refined geocentric astronomical model (Aristotelian inspiration), being authoritative until Copernicus.

The book<sup>3</sup> begins with references to Hipparchus of Bithynia, a Greek astronomer from the second century B. C. He mentions a table of chords made by Hipparchus and that will be extended and developed later in the book. This new table of chords will be used as a geometric tool and will allow Ptolemy to build his astronomical model. The first part of the Almagest (Book 1, Chaps. 9, 10, 11) is dedicated to the mathematical construction of the table of chords, quite equivalent to the sine

---

<sup>3</sup>We cannot read neither the Greek, nor the Arabic, nor the Latin. The document of work, which is our, is the French translation of the abbot Halma, at the beginning of the nineteenth century, from a Greek copy of the Middle Ages (Delambre, 1988). It exists Greek and Arabic copies of the Almagest from the end of the Middle Ages.

**Fig. 1.1** The length of a chord associated with different arcs



function for angle measurement values from 0 to 180 degrees. We will quickly explain here this construction and try to highlight conception of trigonometry (or what could be understood as trigonometry<sup>4</sup>) at the time of Ptolemy. As he will use sexagesimal numeration throughout, he takes a radius equal to 60.

For the construction of his table of chords, Ptolemy's goal is to find the length of a chord associated with different arcs (see Fig. 1.1), ranging from 1/2 to 180 degrees, by increments of 1/2 degree.<sup>5</sup>

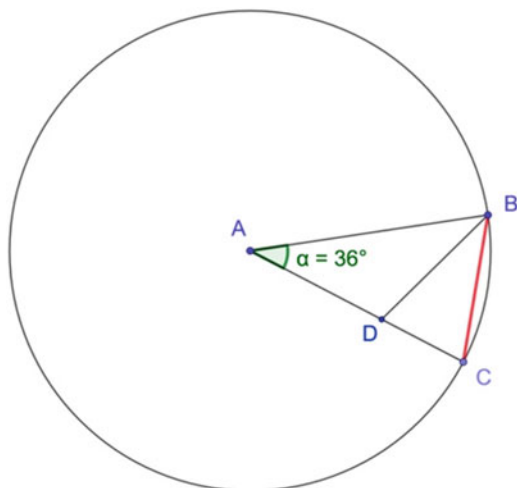
The first chord evaluated by Ptolemy is the chord for an arc of 36 degrees. He builds the bisection of one of the angles at the base of the triangle created by the arc and the centre of the circle and creates two similar triangles (see Fig. 1.2). Considering a simple proportion, he finds that the chord for an arc of 36 degrees is equal to  $\sqrt{3600 + 900} - 30$ , which is equal to 37; 4, 55.

The second chord evaluated by Ptolemy is the chord for an arc of 72 degrees. In order to do it, he refers to a Euclidian theorem: "If a regular pentagon is inscribed in a circle, the square on the side of the pentagon is equal to the sum of the square on the side of the regular hexagon and the square on the side of the regular decagon inscribed in the same circle" (Euclid, Elements, Book XIII, proposition 10). This lead easily to the fact that the length of the chord for an arc of 72 degrees is equal to

<sup>4</sup>Let's mention that the word "trigonometry" as never been used by the mathematician from antiquity. The word will appear with Regiomontanus, mathematician of the Renaissance who will translate Ptolemy's Almagest (Charbonneau, 2002).

<sup>5</sup>The use of degree for measuring the angle was already done by the Mesopotamian astronomers, the Greek astronomers will continue to subdivide the circle in 360 degrees and used the sexagesimal numeration for their calculations. It is not the case for mathematicians like Euclid or Archimedes (Charbonneau, 2002).

**Fig. 1.2** The length of a chord associated with an arc of 36 degrees ( $chord(36^\circ)$ )



$\sqrt{60^2 + chord^2(36^\circ)}$ . Knowing the length of the chord for an arc of 36 degrees, he finds that the chord for an arc of 72 degrees is equal to 70; 32, 3.

In the next section of the book, Ptolemy gives the demonstration (from Euclidian theorems) of a proposition (which is now known as the Ptolemy's theorem): "If a quadrilateral is inscribed in a circle, the product of the measures of the diagonals is equal to the sum of the products of the measures of the opposite sides" (Book 1, Chap. 9). Considering a particular case of the proposition (when one side of the quadrilateral is a diameter), he builds the formula that will allow him to calculate the length of a chord associated with an arc which is the difference between two arcs for which we already know the chord. The formula is this one:  $120 \cdot chord(\beta - \alpha) = chord(\beta) \cdot chord(180 - \alpha) - chord(\alpha) \cdot chord(180 - \beta)$ . Applying this formula for the already known arcs of 72 degrees and 60 degrees, he obtains that  $chord(12^\circ) = chord(72^\circ - 60^\circ) = 12; 32, 36$ .

In the next section, Ptolemy gives the demonstration (again using simple Euclidian theorems) that if we have two given arcs  $\alpha$  and  $\beta$ , with  $2\alpha = \beta$ , we have that  $chord^2(\alpha) = \frac{chord^2(\beta)}{4} + \left(60 + \sqrt{60 - \frac{chord^2(\beta)}{4}}\right)^2$ . Knowing the chord for 12 degrees, this result allows him to do, successively, the calculation of the length of the chord for an arc of 6 degrees, 3 degrees, 1; 30 degree and 0;45 degree. So, at this point, he has calculated the length of all these chords:

$$chord(36^\circ) = 37; 4, 55$$

$$chord(72^\circ) = 70; 32, 3$$

$$chord(60^\circ) = 60$$

$$\text{chord}(90^\circ) = 84; 51, 10$$

$$\text{chord}(120^\circ) = 114; 7, 37$$

$$\text{chord}(12^\circ) = 12; 32, 36$$

$$\text{chord}(6^\circ) = 6; 16, 49$$

$$\text{chord}(3^\circ) = 3; 8, 28$$

$$\text{chord}(1; 30^\circ) = 1; 34, 15$$

$$\text{chord}(0; 45^\circ) = 0; 47, 8$$

As Ptolemy obtains the length of the chord for an arc of  $3/2$  degree and for an arc of  $3/4$  degree, he will claim that “the chord for  $3/2$  is known, the chord associated with the third of this arc cannot be determined by geometric methods” (Delambre, 1988). This refers directly to the angle trisection problem. Facing this deadlock, he will then search for a kind of interpolation between the chord of  $3/4$  degree and of  $3/2$  degree. He first shows that if we have two given arcs  $\alpha$  and  $\beta$ , with  $\alpha < \beta$ , we have that  $\frac{\beta}{\alpha} > \frac{\text{chord}(\beta)}{\text{chord}(\alpha)}$ . This will lead him to the fact that  $\text{chord}(1^\circ) < \frac{4}{3} \cdot \text{chord}(\frac{3}{4}^\circ) = 1; 2, 50, 40$  and that  $\text{chord}(1^\circ) > \frac{2}{3} \cdot \text{chord}(\frac{3}{2}^\circ) = 1; 2, 50$ . Considering these results, he evaluates the length of the chords for an arc of 1 degree as 1; 2, 50, and the chords for an arc of  $1/2$  degree as 0; 31, 25.

Having found what he was looking for, Ptolemy can now build his table ranging from  $1/2$  to 180 degrees, by increments of  $1/2$  degree. His calculations are done until the seconds for the length of the chords<sup>6</sup> (Fig. 1.3).

As we can see, trigonometry is understood and practised in slightly different manners from what we can usually encounter in schools. First, the idea is not to reason on triangles, but on the length of chords associated with given arcs in a circle. The word “sine” comes from the Latin word “sinus” that means a cavity, a hollow or more broadly a gap or an opening.<sup>7</sup> In a way, the idea of Ptolemy is not to explore mathematically the triangle (or to solve right triangle), but to establish the length of different chords in the unit circle. There is something here that can be related to what Pengelley (2011) emphasizes when pointing at different “potentialities” for teachers’ education: “understanding essence, origin” and “initial simplicity”.

From the hermeneutics perspective, we can talk about *inaugural understandings* in mathematics as the history of mathematics can reveal partially lost or occulted senses of mathematics concepts and notions, like trigonometry in the case of

<sup>6</sup>This excerpt does not show all parts of Ptolemy’s table. After the arc column and the chord column, there is a third column labelled “sixtieths”. Numbers in this column gives the average number of sixtieths of a unit that must be added to a given chord each time the angle increases by one minute of arc.

<sup>7</sup>Let’s mention that the words *sinus* come from the translation of *jaib*, which is the Arabic word for cavity or hollow. The word *jaib* is related phonetically to *jiva*, which is the word for chord in Sanskrit.

Fig. 1.3 Excerpt of Ptolemy's table of chords (from Delambre, 1988)

A R C S.		C O R D E S.		
Degrés	Min.	Part. Ju Diam.	Prim	Secon.
0	30	0	31	25
1	0	1	2	50
1	30	1	34	15
2	0	2	5	40
2	30	2	37	4
3	0	3	8	28
3	30	3	39	52
4	0	4	11	16
4	30	4	42	40
5	0	5	14	4
5	30	5	45	27
6	0	6	16	49
6	30	6	48	11
7	0	7	19	33
7	30	7	50	54
8	0	8	22	15
8	30	8	53	35
9	0	9	24	54
9	30	9	56	13
10	0	10	27	32
10	30	10	58	49
11	0	11	30	5
11	30	12	1	21
12	0	12	32	36

Ptolemy, that is grounded more concretely in the experience of life and culture, maybe in a more sensuous and direct mode of being in mathematics (simpler would say Pengelley (2011)) for this particular example. When engaging with these *inaugural understandings* of trigonometry, there is an irresistible desire to establish a kind of dialogue between past and present in the search of a sort of reconciliation, reevaluation and reconstruction of meaning. As developed earlier, in the context of teachers' education, the idea is not to establish a sort of chronological and geographical filiation with the work of Ptolemy, but to set an interpretive dialogue in view of pedagogical and didactic reflections.

In the particular case of Ptolemy's trigonometry, one of the first didactic problems that could be discussed concretely is the central difficulty of the transition from the trigonometry of the triangle to the trigonometry of the circle in secondary school. Indeed, there is the classic teaching problem emerging from the fact that the definition of sine is given first as a ratio and then as a coordinate. The case of Ptolemy's trigonometry could help to make this problem more visible for the future teachers. The reconciliation that the exploration of these *inaugural understandings* of trigonometry could help to build, for the classroom, a reconciliation between the trigonometry of the triangle to that of the circle.

More concretely, this exploration could help to foster teaching strategy in this sense. For instance, we can think about using a trigonometric table with students instead of the calculator for a while. This table could be constructed by the students themselves. Plus, we could see within this table already a functional aspect between the arc and the value of sine, cosine or tangent. Identification of trigonometric identities could also easily be done with this table. The reflection on borderline cases like sine, cosine or tangent of 0 or 90 degrees could also be discussed. Another teaching strategy, inspired by these the exploration of these *inaugural understandings*, could be to take time to discuss the case of the triangle with a hypotenuse of one unit long (just like Ptolemy takes a radius of 60). This could help to have already the students working with different "definition" of sine, as ratio, in this case, become lengths. Finally, the question of teaching first trigonometry of the circle could also be discussed, as the trigonometry of the triangle is usually introduced first.

This said, the introduction of the history of mathematics in mathematics education is not an easy task, and constructive encounters with *inaugural understandings* do not happen straight away. More concretely, on the side of the trainer, there is a need to engage, support, and accompany the students with inclusive gestures in their interpretative ordeal, but also to offer, highlight, challenge, and expound interpretations, as someone who has developed (at least potentially) a certain sensibility regarding the manifestations of different voices (from the present and the past) involved in this special encounter (see Guillemette, 2017, 2020). In a way there are very subtle pedagogical challenges emerging from the exploration of *inaugural understandings*, because there is a need to "live a distance" in order to figure out the mediation of mathematics by the surrounding culture and the social dimensions of mathematical activity. If the encounter with the history is not prepared enough, there is a risk of missing the encounter itself because of a much too large semantic distance between the students and the text, making it impossible to cope with distant voices.

## **A Source for Epistemological Reflections in Mathematics Education**

More broadly, the exploration of these *inaugural understandings* could be a source for more fundamental reflections in mathematics education. As Barbin (2012) emphasizes, the history of mathematics could bring us to a more cultural

understanding of mathematics by inviting historical-anthropological reflection on mathematical activity and a repositioning of the discipline as a human activity. This dimension could help to begin a reflection on the contents and the programs with prospective teachers. As we have seen, the exploration of *inaugural understandings* may help to foster pedagogical and didactic reflection, but, within this search for a sort of reconciliation, reevaluation and reconstruction of meaning, the reflection could reach epistemology of mathematics and fundamental aspects of teaching and learning mathematics.

In this sense, the history of mathematics in the context of teachers' education could have a critical function. A critical function that would find its point of tension in the confrontation with the history of science, techniques and objectivist philosophies which have remained anchored in naturalism and scientific universalism, as the encounter with unusual forms of objects and mathematical activities reveals both the historicity of mathematics and its cultural dimension. As Barbin puts it: "The history of mathematics is a source of epistemological astonishment" (2012, p. 552), and thus could invite for a reevaluation, not only of notions meanings and possible meanings, but also of mathematics and mathematical thinking itself. Indeed, for Radford et al. (2007), it is precisely in highlighting and understanding the link between past and current knowledge that the history of mathematics contributes the most to enriching the perception of the discipline and understanding of its genesis and its epistemology.

Regarding mathematics education and the process of teaching and learning mathematics, the history could play a major role by provoking fundamental reflections with the students. For Radford (2016), the common denominator of sociocultural theories is the claim that human beings are consubstantial with the culture in which they live, that is to say, "The way in which human beings think, take action, feel, imagine, hope, and dream is deeply entangled in the historically constituted forms of thinking, sensing, feeling, and interacting that they find in their culture" (pp. 1–2). Within sociocultural approaches, there is an attempt to get away from the individualist and idealist approaches of the mind which understand the development of subjectivity as an ahistorical and a-cultural phenomenon and culture as a source of stimuli to which humans adapt and develop themselves. The exploration of the history of mathematics could foster some insights about these contemporary perspectives. For more in-depth discussion on the sociocultural point of view on the potential of the history of mathematics for the learning of mathematics and example of prospective teachers' classroom activities, see Guillemette (2015, 2020).

As we already discuss, with the example of Ptolemy's trigonometry, there is a possibility to discuss how these mathematical practices are grounded concretely in the experience of life and culture. By pointing out to the links between past and present modes of doing and being in mathematics, this exploration could also be an invitation to consider, in our context, teaching and learning mathematics in accordance with the way in which teachers and students engage in classroom activity. An invitation to attend to the sensuous manners in which, today, teachers and students bring mathematical ideas to the fore and produce mathematical meanings, sensuous manners which could include perceptual activity, gestures, kinesthetic actions,



posture, language, and the use of artifacts, symbols, graphs or diagrams for instance, manners that could be discussed, problematized or reinvented. The contextualization that the history of mathematics can provide would be an instrument of analysis as well as a fundamental characteristic of human social life.

The situated cognition movement, and historico-cultural perspective in mathematics education, pointed out that scientific knowledge, too, is embodied, situated, and contextual; and it pointed out that what students' master is not knowledge of a cultural-historically relevant object but knowledge of something else instead, something particular to schools. In this sense, mathematics educators, in the context of teachers' education, could seek, within the exploration of the history of mathematics, to restore to mathematical activity its most precious ontological force, namely, the dynamic locus where human existence creates and recreates itself against the backdrop of culture and history.

## Conclusion

The exploration of the history of mathematics and its potential for mathematics education have been discussed extensively, particularly in the context of mathematics teachers' training. One of the principal goals that have been put forward is to explore, with prospective teachers, their own mathematics knowledge, and epistemological assumptions, by experiencing and reflecting on the contrast between modern concepts and their historical counterparts. In this chapter, we have presented and detailed a specific theoretical position and conceptualization regarding what we have called *inaugural understandings* in mathematics education. Revelled in the interpretive dialogue that the history of mathematics could bring, these *inaugural understanding* are associated with different partially lost senses of mathematics concepts and notions that are grounded concretely in the experience of life and culture of mathematicians from the past. We took the time to exemplify our point with the exploration of the work of Ptolemy, regarding trigonometry in the Greco-Roman world.

Possible implications for teachers' education practices have also been suggested, especially related to the example of Ptolemy's work. We attempt to introduce and to develop a bit the idea that the exploration of these *inaugural understandings* could foster didactic and pedagogical reflections, but could also play a major role like provoking fundamental reflections with the students about mathematics education. We proposed that it is particularly the case with the introduction of major theorization and conceptualization in mathematics education such as embodied or situated cognition or historico-cultural perspectives. In this sense, we addressed, in a particular manner and in a specific perspective, the need for the development of theoretical positioning and conceptual basis in the field. Putting emphasis on preservice and in-service teachers' education.

Finally, we would like to emphasize again the importance of these educational practices, alongside investigation of the theoretical developments on the subject and

of the implementation of these practices. The reason is that the latter seems to have the potential to highlight, which is quite difficult to imagine in another educational context, the very fundamental cultural aspect of mathematical activity, as well as the social and cultural perspective on mathematics and mathematics education. A reflection that, we believe, is crucial to reinterpret and to develop the meaning and the orientation of mathematics education itself.

## References

- Arcavi, A., & Isoda, M. (2007). Learning to listen: From historical sources to classroom practice. *Educational Studies in Mathematics*, 66(1), 111–129. <https://doi.org/10.1007/s10649-006-9075-8>
- Ball, D. L. (1993). With an eye on the mathematical horizon: Dilemmas of teaching elementary school mathematics. *The Elementary School Journal*, 93(4), 373–397. <https://doi.org/10.1086/461730>
- Barbin, É. (1997). Histoire et enseignement des mathématiques : Pourquoi? Comment? *Bulletin de l'Association mathématique du Québec*, 37(1), 20–25.
- Barbin, É. (2012). L'histoire des mathématiques dans la formation : Une perspective historique (1975–2010). In J.-L. Dorier & S. Coutat (Eds.), *Acte du congrès de l'Espace mathématiques francophone 2012* (pp. 546–554). University of Genève.
- Barbin, É., Guillemette, D., & Tzanakis, C. (2020). History of mathematics and education. In S. Lerman (Ed.), *Encyclopedia of mathematics education* (2nd ed., online). Springer. [https://doi.org/10.1007/978-3-030-15789-0\\_69](https://doi.org/10.1007/978-3-030-15789-0_69)
- Charbonneau, C. (2002). La trigonométrie : une histoire à l'envers tournée d'abord vers le ciel. In I. L. Juneau & S. Viau (Eds.), *Actes du 44<sup>e</sup> congrès annuel de l'AMQ* (pp. 47–56). Le Griffon d'Argile.
- CIEAEM. (2000). *50 years of CIEAEM: where we are and where we go: "manifesto 2000 for the year of mathematics"*. [https://www.cieaem.org/images/Documents/CIEAEM\\_Manifesto/CIEAEM\\_Manifesto.pdf](https://www.cieaem.org/images/Documents/CIEAEM_Manifesto/CIEAEM_Manifesto.pdf). Accessed 16 May 2022.
- Clark, K., Kjeldsen, T. H., Schorcht, S., Tzanakis, C., & Wang, X. (2016). History of mathematics in mathematics education: Recent developments. In L. Radford, F. Furinghetti, & T. Hausberger (Eds.), *Proceedings of the 2016 meeting of the international study group on the relations between the history and pedagogy of mathematics* (pp. 135–179). IREM de Montpellier.
- Delambre, M. (1988). *Composition mathématique de Claude Ptolémée ou astronomie ancienne*. Blanchard.
- Fauvel, J., & van Maanen, J. (Eds.). (2002). *History in mathematics education: The ICMI study*. Kluwer Academic Publishers. <https://doi.org/10.1007/0-306-47220-1>
- Freudenthal, H. (1983). *The didactic phenomenology of mathematical structures*. Reidel.
- Fried, M. N. (2014). History of mathematics in mathematics education. In M. R. Matthews (Ed.), *International handbook of research in history, philosophy and science teaching* (pp. 669–703). Springer Science+Business Media. [https://doi.org/10.1007/978-94-007-7654-8\\_21](https://doi.org/10.1007/978-94-007-7654-8_21)
- Fried, M. N., Guillemette, D., & Jahnke, H. N. (2016). Theoretical and/or conceptual frameworks for integrating history in mathematics education. In L. Radford, F. Furinghetti, & T. Hausberger (Eds.), *Proceedings of the 2016 ICME satellite meeting of the international study group on the relations between the history and pedagogy of mathematics* (pp. 211–230). IREM de Montpellier.
- Furinghetti, F., Jahnke, H., & van Maanen, J. (2006). Mini-workshop on studying original sources in mathematics education. *Oberwolfach Reports*, 3(2), 1285–1318.

- Gadamer, H. G. (1991). *L'art de comprendre : Herméneutique et champ de l'expérience humaine*. Aubier.
- Glaubitz, M. R. (2011). The use of original sources in the classroom: Empirical research findings. In É. Barbin, M. Kronfellner, & C. Tzanakis (Eds.), *History and epistemology in mathematics education: Proceedings of the 6th European Summer University (ESU 6)* (pp. 351–362). Holzhausen Publishing Ltd..
- Grondin, J. (2011). *L'herméneutique* (3rd ed.). Presses Universitaires de France.
- Guillemette, D. (2015). Rôle de l'histoire des mathématiques dans l'enseignement-apprentissage des mathématiques : le point de vue socioculturel. In C. Sabena & B. Di Paola (Eds.), *Actes de la 67<sup>e</sup> Réunion de la Commission internationale pour l'étude et l'amélioration de l'enseignement des mathématiques (CIEAEM 67) – Enseigner et apprendre les mathématiques : ressources et obstacles* (pp. 607–618). CIEAEM.
- Guillemette, D. (2017). History of mathematics in secondary school teachers' training: Towards a nonviolent mathematics education. *Educational Studies in Mathematics*, 96(3), 349–365. <https://doi.org/10.1007/s10649-017-9774-3>
- Guillemette, D. (2020). Lecture de textes historiques dans la formation à l'enseignement des mathématiques : choix et modalités de lecture. In B. Di Paola & P. Palhares (Eds.), *Actes de la 71<sup>e</sup> Réunion de la Commission internationale pour l'étude et l'amélioration de l'enseignement des mathématiques (CIEAEM 71) – Connexions et compréhensions dans l'enseignement des mathématiques : donner un sens à un monde complexe* (pp. 443–454). CIEAEM.
- International Mathematical Union. (2021). *Organization – Affiliated Organizations – HPM*. <https://www.mathunion.org/icmi/organization/affiliated-organizations/hpm>. Accessed 4 Jan 2022.
- Jahnke, H. N. (2014). History in mathematics education: A hermeneutic approach. In M. N. Fried & T. Dreyfus (Eds.), *Mathematics & mathematics education: Searching for common ground* (pp. 75–88). Springer. [https://doi.org/10.1007/978-94-007-7473-5\\_6](https://doi.org/10.1007/978-94-007-7473-5_6)
- Jahnke, H. N., Arcavi, A., Barbin, E., Bekken, O., Furinghetti, F., El Idrissi, A., Silva da Silva, C. M., & Weeks, C. (2002). The use of original sources in the mathematics classroom. In J. Fauvel & J. van Maanen (Eds.), *History in mathematics education: The ICMI study* (pp. 291–328). Kluwer Academic Publishers. [https://doi.org/10.1007/0-306-47220-1\\_9](https://doi.org/10.1007/0-306-47220-1_9)
- Jollivet, S. (2009). L'herméneutique de la facticité et la question du « sens d'être » (1921–1923). In S. Jollivet (Ed.), *Heidegger : Sens et histoire (1912–1927)* (pp. 79–114). Presses Universitaires de France.
- Kjeldsen, T., & Blomhøj, M. (2012). Beyond motivation: History as a method for learning meta-discursive rules in mathematics. *Educational Studies in Mathematics*, 80(3), 327–349. <https://doi.org/10.1007/s10649-011-9352-z>
- Pengelly, D. (2011). Teaching with primary historical sources: Should it go mainstream? Can it? In V. Katz & C. Tzanakis (Eds.), *Recent developments on introducing a historical dimension in mathematics education* (pp. 1–8). The Mathematical Association of America. <https://doi.org/10.5948/upo9781614443001.002>
- Radford, L. (2016). Mathematics education as a matter of labor. In M. A. Peters (Ed.), *Encyclopedia of educational philosophy and theory*. [Living edition]. Springer. [https://doi.org/10.1007/978-981-287-532-7\\_518-1](https://doi.org/10.1007/978-981-287-532-7_518-1)
- Radford, L., Furinghetti, F., & Katz, V. (2007). Introduction: The topos of meaning or the encounter between past and present. *Educational Studies in Mathematics*, 66(1), 107–110. <https://doi.org/10.1007/s10649-006-9076-7>
- Ricoeur, P. (1986). Rhétorique-Poétique-Herméneutique. In M. Meyer (Ed.), *De la métaphysique à la rhétorique* (pp. 143–155). Université de Bruxelles.
- Swetz F. J. (2013). Mathematical treasure: Ptolemy's almagest. *Convergence*. <https://www.maa.org/press/periodicals/convergence/mathematical-treasureptolemy-s-almagest>. Accessed 4 Jan 2022.
- Warnke, G. (1991). *Herméneutique, tradition et raison* (J. Colson, Trans.). De Boeck.

# Chapter 2

## The Value of Historical Knowledge Through Challenging Mathematical Tasks



Luís Menezes and Ana Maria Costa

**Abstract** Learning mathematics does not simply mean acquiring/developing a set of content knowledge. It also means being able to solve problems, think mathematically and communicate ideas with others. If we think about the mathematics taught to prospective mathematics teachers, the study of the nature of mathematical knowledge, mathematical processes and their historical development is fundamental to their future teaching practice. To achieve this goal, we designed a formative experience in which were proposed challenging, historically framed mathematical tasks to prospective mathematics teachers who teach in the early years (Kindergarten and Primary). In this setting, the study aims to understand how challenging mathematical tasks, which bear upon historical context, contributed to student learning in terms of understanding: the nature of mathematics; the historical development of mathematical knowledge and the processes by which it is developed; mathematical concepts and their modes of representation.

The study applies a qualitative and interpretive methodology with the participation of 45 prospective teachers who recently enrolled in the undergraduate programme. The data comes from student resolutions, individual reflections, observations and field notes. The results reveal that as a corollary to working with challenging mathematical tasks framed historically, students have developed their knowledge of mathematics and the nature of mathematical knowledge. They understand the value of problem solving towards an improvement of their historical knowledge and in the development of some fundamental mathematical concepts taught in the initial school years, such as number, operation, regularity, geometric objects.

**Keywords** Learning · Mathematics · Prospective teachers · Historical knowledge · Mathematical tasks

---

L. Menezes (✉) · A. M. Costa  
School of Education – Polytechnic of Viseu, Viseu, Portugal  
e-mail: [menezes@esev.ipv.pt](mailto:menezes@esev.ipv.pt); [anacostalopes@esev.ipv.pt](mailto:anacostalopes@esev.ipv.pt)

© The Author(s), under exclusive license to Springer Nature Switzerland AG 2023  
S. Romero Sanchez et al. (eds.), *The Role of the History of Mathematics in the Teaching/Learning Process*, Advances in Mathematics Education,  
[https://doi.org/10.1007/978-3-031-29900-1\\_2](https://doi.org/10.1007/978-3-031-29900-1_2)

## Introduction

Learning mathematics is much more than knowing mathematical contents. Learning mathematics involves understanding mathematics, being able to reason mathematically, solving problems, communicating and discussing mathematical ideas, having a vision of the evolution of the discipline and its tools and also being able to appreciate it (Cobb, 1994; Heyd-Metzuyanim & Sfard, 2012; Menezes et al., 2015; Sfard, 2001; Weber & Leikin, 2016).

This view of what it means to learn mathematics is valid for students at all levels of education, but it is even more valid for the mathematical training of students who will teach this subject. Even before knowing how to teach it, forthcoming teachers must have an in-depth view of mathematics, the nature of its knowledge, its history and its reasoning processes. Assuming this perspective of learning mathematics, and valuing the role that the History of mathematics (HM) can play in this learning process in terms of understanding its nature, usefulness and social relevance (Barbin et al., 2018; Clark, 2019; Clark et al., 2016; Katz, 2004; Lim & Chapman, 2015; Siu, 2007) this study analyses a training experience. This training involved an undergraduate course (BE - Basic Education) which in Portugal is the first cycle of studies (followed by a two-year professional graduate degree course) for those who wish to become kindergarten teacher or primary school teachers (1st to 6th grades; the first four years of Primary school being taught by a single teacher on his/her own and the two following ones by teachers whose expertise is in the mathematical field and who only teach mathematics). The experiment was accomplished within the Curricular Unit (CU) of Foundations of mathematics (taught in the first semester of the BE undergraduate degree course) and sought to promote learning of mathematics of such kind, giving particular attention to HM and working with historically framed mathematical tasks. Mathematics tasks are a powerful means through which students can learn mathematics in a productive and meaningful way, as described above (Menezes et al., 2015; Stein et al., 2008). Thus, this study aims to understand how mathematical tasks with a historical context contribute to improve learning on the part of forthcoming teachers of the initial school years in terms of understanding mathematical concepts and their modes of representation, the nature of mathematics, the historical development of mathematical knowledge and the ability to value the discipline and its social relevance.

## Learning Mathematics

Mathematics learning has been a very active field of research for many years (Ambrosio, 2006; Cobb, 1994; Sfard, 2001). Among the questions that these studies have sought to answer, the following stand out: (I) What does it mean to learn mathematics? and (ii) What are the most effective strategies for learning mathematics? These two questions are related, so the answer to the second depends on the

answer given to the first. Analysing what research has revealed about what it means to learn mathematics, there is a broad consensus around the idea that this implies much more than knowing mathematical facts and procedures, involving an understanding of the concepts, in situations that are meaningful to the students (Cobb, 1994; Heyd-Metzuyanim & Sfard, 2012; Menezes et al., 2015; Sfard, 2001). This mathematical understanding fosters the development of skills such as reasoning and mathematical communication that allow for students to solve problems and above all learn to solve them. Alongside this learning process, students, increasingly as they progress through schooling stages, must reflect on the nature of knowledge, the processes that allows it to be obtained and its historical framework. In addition, and similarly to what happens in other areas of human activity/school subjects, such as the Arts, students must develop the ability to empathise with mathematics and recognise its growing social relevance. Analysing the question of how to promote this learning, although there are different perspectives on the right answer to be put forward, many hold that it is important to highlight how close the activity students perform in class comes to the activity that historically, human beings have followed and continue to follow. As we know, this human activity consists in the identification of problems with which it is confronted/faced, in the resolution of problems (usually in a collaborative way), in the communication and discussion of the answers found and, finally, in the establishment of the knowledge produced. The exploratory teaching of mathematics, based on solving mathematical tasks (usually problems), promotes this mathematical activity among students (Menezes et al., 2015; Stein et al., 2008). A lesson with this type of teaching is usually organized into three or four phases, depending on whether or not the last one is required: (i) Task Introduction; (ii) Task Resolution; (iii) collective discussion/establishment of knowledge (Stein et al., 2008). In this study, we assume the four phases, considering the fact that the collective discussion is focused on the results of the task and the systematization of learning seeks to establish relationships between previous and newly knowledge (Menezes et al., 2015). The tasks used in this type of lesson must be meaningful to the students, which implies that they are culturally situated, in space and time (Ambrosio, 2006; Cobb, 1994). Reflection on this mathematical activity allows students to understand the nature of mathematical knowledge and its forms of representation, while they gain an appreciation of mathematics and its social relevance.

## **History of Mathematics to Learn Mathematics**

Recommendations for the use of HM in mathematics teaching have existed for a long time, this idea having been even more highlighted in recent years (Clark et al., 2016; Jankvist et al., 2019; Katz, 2004; Mosvold et al., 2014; Pinto & Costa, 2020; Siu, 2007). One of the most common ways of introducing the History of mathematics in the teaching of the subject is through mathematical tasks, based on historical facts within which frame they are set, and which supports mathematics learning

(Barbin et al., 2018; Katz, 2004; Schubring et al., 2000). These tasks can be seen as a simple motivation for the study of a new mathematical topic, or as a means to learn new mathematical topics, within an exploratory teaching approach, or as an application of content already acquired (Clark, 2019; Clark et al., 2016; Katz, 2004).

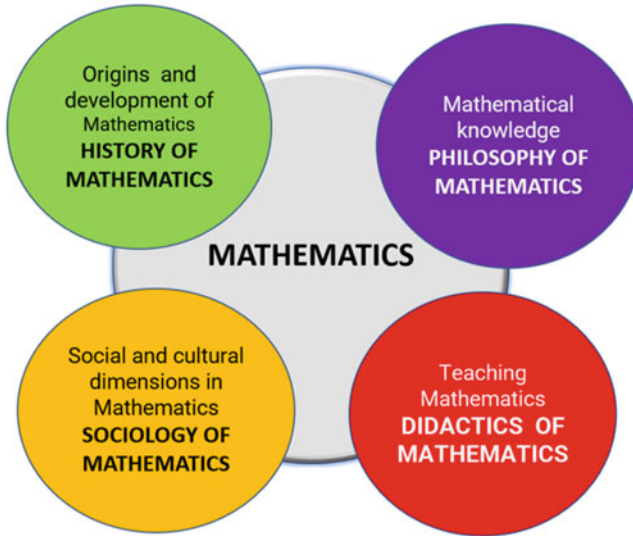
One can account for the introduction of HM in the mathematics class in several ways: (i) It supports the understanding of mathematical content; (ii) It allows for a more humanized view of mathematics; (iii) Motivates students to learn mathematics; (iv) It favours the establishment of connections with reality and with other sciences; (v) Develops skills such as problem solving, reasoning and mathematical communication (Barbin et al., 2018; Clark, 2019; Clark et al., 2016; Katz, 2004; Martins et al., 2021).

The low use of HM in the classroom has to do with a set of constraints that teachers point out, such as: lack of time to deal with the extensive curricula; lack of explicit curriculum guidelines; lack of didactic resources to support teaching; scarcity of teacher training offer in this field (Martins et al., 2021; Siu, 2007). Thus, this study seeks to introduce the History of mathematics into the field of initial teacher training in order to promote the learning of mathematics with meaning and motivation, by enabling students to become familiar with the nature and history of mathematics.

## The Formative Experience

This training experience took place in a Curricular Unit (CU) that is part of the study plan of Basic Education (BE), a three-year degree course, which is currently, in Portugal, the cycle of studies required for undergraduates who want to become kindergarten or primary school teachers, then followed by studies conducive to a specific professional master's degree. Much of the mathematical training of these future professionals is carried out in this first cycle of studies (BE), which, together with training within the scope of mother tongue subject matters/contents/curricular units, represent about a third of the study plan. BE's first mathematics CU, called "Foundations of mathematics", aims to lead students to reflect on their previous mathematical experiences, in secondary education, namely in their view of mathematics, of the nature of mathematical knowledge, the processes of production and validation of this knowledge, the historical evolution of this knowledge and its relationship with the cultures where it arose. This reflection, which combines History and Philosophy of mathematics, also aims to deepen students' mathematical knowledge in topics such as Numbers and Operations, Geometry and Measurement and Algebra. Schematically, this curricular unit is organized around four major thematic areas, with the History of mathematics playing an important role (Fig. 2.1).

Working with the History of mathematics involved reading texts about the evolution of mathematical knowledge (from the first manifestations of mathematical thinking in the Paleolithic to the present day, crossing great ancient civilizations, such as the Ancient Egyptian, Mesopotamian, Ancient Greek and Islamic).



**Fig. 2.1** Thematic areas of the Foundations of mathematics course

Alongside the reading and discussion of these texts, students undertook the resolution, discussion and reflection of mathematical tasks corresponding to problems posed/solved by different civilizations.

The assignments proposed followed an exploratory approach to the teaching of mathematics, bearing on the four phases: (i) introduction of the task to the students; (ii) Task resolution by students; (iii) Collective discussion of the task results; and (iv) systematization of learning. The proposed tasks aimed to promote learning, alongside with an understanding of mathematical concepts (somewhat unusual for those students at the time when they enrol in Higher Education, despite its unquestionable importance), at the same time that it is intended students are led towards a more humanized view of Mathematics and an understanding of the nature of its knowledge and its production processes.

Much as the historical context was important in all the four phases the first and last were more the most relevant ones. The first provided the context and reasons for the students to solve the tasks. The latter, favoured holistic learning of Mathematics, showing connections between concepts and displaying its value as a significant human activity.

Below is one of the tasks related to Ancient Egypt (Fig. 2.2). With this task, students should understand mathematics as an activity used to solve problems posed to the Egyptians in their daily lives, which led this people to the development of mathematical ideas and respective forms of representation and communication. In addition, the task also aimed at deepening the concepts of fraction and fractional number, leading students to analyze an algorithm used by the Egyptians and to prove mathematical relationships resulting from it. Mathematics developed in Ancient Greece was presented as a turning point in mathematical thinking, bringing it closer to the goals and methods of current mathematics.



The Egyptians represented, in hieroglyphics, the unit fractions placing the symbol  $\circ$  over the symbol representing the denominator. For example,  $\frac{1}{13}$  was represented by  $||| \circ$ .

Any non-unit fraction, with the exception of  $\frac{2}{3}$ , did not have a particular symbol. They were represented by sums of unit fractions.

The fraction  $\frac{2}{3}$  was represented in hieroglyphics by  $|| \circ$ .

In the famous papyrus of Rhind, one of the few sources of Egyptian mathematics and one of the oldest texts that is known, there appears a list that gives a representation of the fractions of the form  $\frac{2}{n}$  as the sum of distinct unit fractions,  $n$  being odd and varying from 3 to 101.

For example, the fraction  $\frac{2}{13}$  is represented in the Rhind papyrus by the sum  $\frac{1}{8} + \frac{1}{52} + \frac{1}{104}$ .

#### Algorithm

This is an algorithm that allows you to write any fraction as a sum of unit fractions. Let's see how it works for the fraction  $\frac{2}{5}$ .

1) Subtract the largest possible unit fraction. Like  $\frac{2}{5} = 0,4$  the fraction to be subtracted from  $\frac{2}{5}$  is  $\frac{1}{3}$ .

2) A new fraction is obtained.  $\frac{2}{5} - \frac{1}{3} = \frac{1}{15}$

3) As the fraction obtained is a unit fraction, we finished the procedure.

We have then  $\frac{2}{5} = \frac{1}{3} + \frac{1}{15}$

If the fraction obtained was not unitary, we would apply steps 1) and 2) again to the new fraction.

- Apply the algorithm to the fraction  $\frac{2}{13}$  and compare the result obtained with the representation of  $\frac{2}{13}$  on the papyrus of Rhind.
- Prove:  $\frac{1}{a} = \frac{1}{a+1} + \frac{1}{a \times (a+1)}$ ,  $\forall a \in \mathbb{N}$ .
- Given the previous result, obtain another representation of  $\frac{2}{13}$  as the sum of unit fractions.
- Find the first fraction of the form  $\frac{2}{n}$ , with odd  $n$ , for which the algorithm is applied more than once.

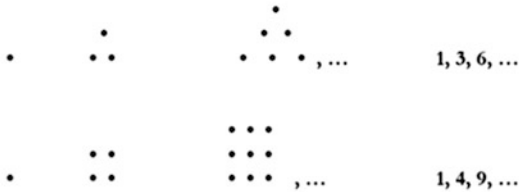
Fig. 2.2 Task on Egyptian algorithm (Ancient Egypt)

The more intellectualized, sometimes even playful, character of mathematics developed in Ancient Greece is exemplified by the task presented in Fig. 2.3.

With this task it was intended that the students understand the turn that occurred in mathematics in Ancient Greece, pertaining to the Greek culture of that historical period. In mathematical terms, it was intended to work representations of numbers, sequences and regularities and an essential aspect of mathematical reasoning: generalization. Furthermore, this task provided an opportunity to explore divisibility.

## Numbers in Ancient Greece

1. The arrangement of points representing numbers in triangular, square, pentagonal, etc. schemes it will have taken into account the succession of triangular numbers, square numbers, pentagonal numbers, etc.



1.1 Determine the first ten terms of the triangular numbers succession ( $t_n$ ) and of the square numbers succession ( $q_n$ ).

1.2 Write the general expressions of the two successions, ( $t_n$ ) and ( $q_n$ ).

1.3 Investigate the relationship between square numbers and triangular numbers.

2. The search for rectangular schemes to represent numbers will have led to the concept of divisibility.

2.1 What kinds of rectangular representations support prime numbers? What about composite numbers?

2.2 For each of the representations of the rectangular numbers, what does the number of rows and columns represent?

2.3 Investigate other relationships of rectangular numbers.

**Fig. 2.3** Task on figured numbers (Ancient Greece)

The work developed with these tasks surprised the students because they were not familiar with historically framed tasks, nor did they see mathematical knowledge as a human response to their problems and interests. The students were also highly motivated in solving and discussing the results of the tasks, reinforcing their ability to think and communicate mathematically.

## Methodology

This study adopts qualitative and interpretive research methods as the data collected are qualitative and the aim is to understand the phenomena (Allan, 2020; Erickson, 2012). The data collected for this study resulted from: (i) solving mathematical tasks (Figs. 2.2 and 2.3), performed individually; (ii) Observation of task resolution; (iii) Written reflection on the potential of tasks for learning mathematics; and (iv) peer

**Table 2.1** Themes and categories of analysis

Analysis themes	Categories of analysis
Mathematical activity of students with mathematical tasks	Involvement of students in carrying out mathematical tasks
	Use of mathematical concepts and representations in solving tasks
Importance of HM-based mathematical tasks for student learning	Impact of HM on learning mathematical content
	HM's role in building a holistic view of the discipline
	Impact of HM for the appreciation of mathematics (affective domains)

work on a period of recognition and historic growth for Mathematics, encompassed by a broader and more general historical framework, contributing to its development. A total of 45 students participated in the study, most of them female, aged between 18 and 19 years old, starting their BE undergraduate studies, the first cycle required for granting access to a professional master's course that will enable them to teach children aged 3–5 years, 6–9 years or 10–12 years. For data analysis, two themes were established according to the objectives of the study and the theoretical framework: (i) Mathematical activity of students with mathematical tasks; and (ii) Importance of HM-based mathematical tasks in student learning. For each of these themes, categories of analysis were defined as shown in Table 2.1.

The categories of analysis were applied systematically to all records (solving mathematical tasks, reflections and field notes of observations). This was a recursive process, as the categories showed changes after successive cross – checking with the data. In the next section, evidence is presented by “ $S_i$ ”, representing “S” student and in index “ $i$ ” the random number assigned to each student.

## Results

This section presents the results according to the two defined themes and in each of them within the defined categories:

### *Mathematical Activity of Students with Mathematical Tasks*

#### **Involvement of Students in Carrying Out Mathematical Tasks**

The students were very involved in the classes, both in carrying out the tasks based on HM and in the analysis and discussion of texts about HM which supported the ongoing tasks, showing motivation, curiosity, willingness to be challenged and

commitment to their work. Such disposition and behaviour was visible, in class, during the performance of the tasks and in the written reflection that they made about this mathematical activity based on HM: “The History of mathematics is a motivating and provoking element of students’ curiosity” (St23); “This new way of looking at mathematics made me curious to listen and learn, something [mathematics] I never thought I wanted” (St 13).

### Use of Mathematical Concepts and Representations in Solving Tasks

Students mobilize mathematical knowledge and representations to solve mathematical tasks. In the case of the Egyptian algorithm task (Fig. 2.2), in order to write the fraction  $\frac{2}{13}$  as the sum of two-unit fractions, students are given the opportunity to revisit the representations (Egyptian and current) and fraction meanings (in particular of the unitary) and to understand how important these fractions were for the ancient Egyptians in their quest to solve their daily problems (Fig. 2.4).

Still on the subject of obtaining unit fractions, the students were invited to try a simple mathematical demonstration, understanding the value that demonstrations represent for mathematics (aspect they tend to devalue), involving processes of abstraction, symbolization, formalization and generalization (Fig. 2.5).

In the Figured numbers task (Fig. 2.3), students understand that numbers can be represented in many ways other than symbolic. In this case, students understand the value of pictorial representation, bringing numbers closer to geometric shapes. In this task, in triangular numbers, students work on the generalization of nearby terms (by a process of recurrence) and of the general term (generalizing the infinite sequence:  $1, 1 + 2; 1 + 2C3; 1 + 2 + 3+ 4+ \dots$ ) (Figs. 2.6 and 2.7).

- Apply the algorithm to the fraction  $\frac{2}{13}$  and compare the result obtained with the representation of  $\frac{2}{13}$  on the papyrus of Rhind.

$$\Leftrightarrow \frac{2}{13} - \frac{1}{7} = \frac{14}{91} - \frac{13}{91} = \frac{1}{91}$$

$$\frac{2}{13} = \frac{1}{7} + \frac{1}{91}$$

Fig. 2.4 Task resolution (St. 33)

Prove:  $\frac{1}{a} = \frac{1}{a+1} + \frac{1}{a \times (a+1)}$ ,  $\forall a \in \mathbb{N}$ .

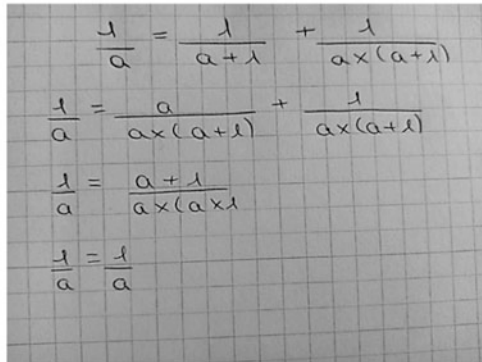


Fig. 2.5 Task resolution (St. 14)

Obtain the first ten terms of the sequence of triangular numbers (tn) and of the sequence of square numbers (qn).

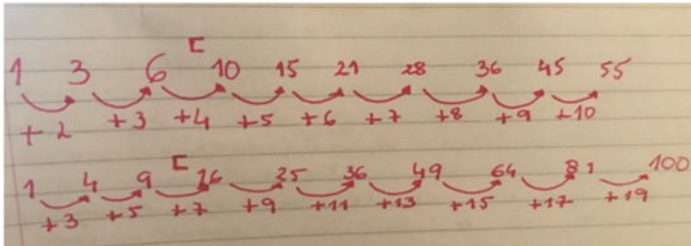


Fig. 2.6 Task resolution (St. 15)

Fig. 2.7 Task resolution (St. 36)

$$\begin{aligned}
 &1 \\
 &1 + 2 \\
 &1 + 2 + 3 \\
 &1 + 2 + 3 + 4 \\
 &\dots \\
 &1 + 2 + 3 + 4 + \dots + n = n \times \frac{1+n}{2}
 \end{aligned}$$

Regarding rectangular numbers, students were asked to establish relationships with divisibility, prime numbers, composite numbers, even and odd numbers. Students, accustomed to treating this theme in the strict field of numbers and operations, were able to establish a connection with Geometry:

For each of the rectangular number representations, what do the number of rows and columns represent? Rectangular numbers are formed from the organization of their points in rectangular figures, with the numbers of rows and columns representing the divisors of the numbers. (St 3)

The prime numbers can only be done in a row or in a column, because they are only divided by themselves and by 1, while in composite numbers, they can be divided by other numbers. (St 17)

Most students established a relationship between the sequence of square numbers and that of triangular numbers, algebraically and geometrically (Figs. 2.8 and 2.9).

## ***Importance of HM-Based Maths Tasks to Student Learning***

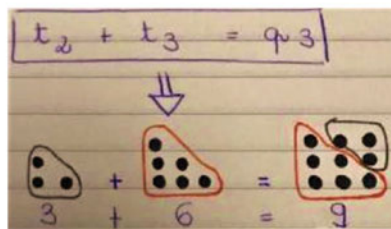
### **Impact of HM on Learning Mathematical Content**

Students report that working with HM, in particular with tasks, allowed them to enlarge their mathematical knowledge with new concepts and to give meaning to others they had learned before: “Studying the history of mathematics allowed me to know more concepts that were not new, allowed me to understand concepts that I had already heard about, but did not know their meaning.” (St 35). The learning of mathematical symbology, so important in this discipline, is pointed out by some students, underlining its creation and evolution in view of its role in symbolising mathematical ideas: “Many of the concepts I knew previously changed after this study, where I was able to understand aspects as the creation and evolution of symbols” (St 9); “mathematics has evolved over time and by studying the history

Being  $T_n$  the designation of a triangular number  $n$  and  $Q_n$  the designation of a square number  $n$ , we arrive at the expression:  $T_n + T_{n+1} = Q_{n+1} = (n+1)^2$

**Fig. 2.8** Task resolution (St. 13)

The sum of two consecutive triangular numbers is equal to the square number corresponding to the order of the added triangular number. For example, as follows:



**Fig. 2.9** Task resolution (St. 3)

of mathematics we have seen its evolution, we have followed the transformation of writing, for example, before the Greeks used dots to represent numbers (figured numbers)”(St. 17).

Working with mathematical tasks allowed students to know the origin and evolution of concepts, such as numerical and pictorial sequences, divisibility and fractions: “Tasks like this are quite relevant, as they allow me to learn more about the origin and the evolution to the present day of everything I learned to get here.” (St. 24) “This task makes us learn about square numbers and triangular numbers, which came from the Pythagorean School. When we know the history of mathematics, we understand where these numbers came from, how and where they were used and who created them”. (St. 15),

The learning of mathematics with a spatio-temporal context is pointed out by several students, learning mathematics and History in an integrated way: “We were able to place great ideas and problems both in space and in time. It also helps understanding the construction of concepts,” (St 21). The same student underlines the impact of HM on her learning by favoring the establishment of mathematical connections: “HM provides an important context that allows students to establish relationships between mathematical concepts and life events. Learning depends on the ability of the student to establish connections between different types of knowledge.” (St 21).

For many students, HM is seen as a motivation for learning mathematics, showing how and why many concepts emerged:

This semester (...) I learned more about what I had learned so far, the origin, how it evolved to reach us and how important it is to always try to know the history of the contents to captivate us and to often find the answer to the “why?” the existence of a certain content. (St. 26)

### **HM’s Role in Building a Holistic View of the Discipline**

HM contributed to the development, on the part of most students, of a more complete view of what mathematics is, who no longer conceive it as something static and finished, but, on the contrary, as something that is constantly evolving, having a past, a present and a future. In addition, students become aware of the social relevance of mathematics and its presence in most things and situations in our life:

Over this time, I conclude that mathematics really is much more important than I imagined, much more complex and that it really is everywhere. I realized where it came from, I discovered its past and its evolution to the present day, I managed to conclude that mathematics has no end, (at least an end foreseen for so soon). (St 26)

These assignments, in addition to showing much of the development that our ancestors undertook, demonstrating how much they have already managed to progress and how much we can still progress and develop constantly, helped to broaden my academic horizon and gave me a different perspective of what Maths is. (St 13)

Now (...) it showed me another side of mathematics that I did not know: how it was developed, how it is present in everything and how it can exist, even though there is nothing physical in mathematical knowledge or in mathematical entities. (St 17)

Some students refer to a change in their conception of what mathematics is, expanding their view of mathematical knowledge, consolidating the process of abstraction that leads to the construction of this knowledge: “At this moment, I realize that [mathematics] is much more than just numbers and figures, but behind these there is an abstract thought, which allows for the evolution of knowledge and how important it is to be worked on” (St. 7).

Mathematics comes to be understood as a problem-solving science, in which creativity and the relationship between people take on an important role:

Tasks like these are very important to understand mathematics as a science of logical and abstract reasoning, which studies measures, quantities, variations... Mathematical knowledge can be acquired through dialogue, questions, intuition, creativity, interaction. with each other and with the world around us, through previously known mathematical concepts and lived experiences. From a very early age, man starts attempting to solve everyday problems. Mathematics is always present in our lives. All in all, mathematics is a science that helps us understand the world around us. (St. 11)

### **Impact of HM for the Appreciation of Mathematics (Affective Domains)**

In addition to the impact of HM on some aspects of a cognitive nature, related to the learning of mathematical concepts, students indicate impacts of an affective nature: taste and appreciation of mathematics. Usually, a substantial part of the students who start the BE Undergraduate Study course are not shown to view mathematics in a pleasant way, not being fully aware of its social relevance. Working with HM, namely performing mathematical tasks such as those shown in Figs. 2.2 and 2.3, contributed to substantial changes in this sense. HM, by providing a framework to what was being studied and by broadening horizons in terms of mathematical knowledge, brought about an appreciation for the discipline:

Now, I understand that [HM] is a fundamental aspect, to understand much better what we are studying and what we are solving. With the work we did, I came to develop a taste for mathematics, a discipline I had always seen as consisting of mere calculations, outside a context. (St. 7)

Appreciation of mathematics also resulted from seeing mathematics as a human activity, an activity of confronting and overcoming problems of people, like us, over thousands of years: “The way I appreciated mathematics changed a bit, because when I learned more about its history, the efforts that were made for the sake of its evolution, so that mathematics holds its present day status, touched me” (St. 27).

The study of HM made it possible to develop a positive relationship with the discipline, leading some students to recommend its more widespread use in the classroom (supported by teacher training) to combat negative views that still persist about the discipline:

The study of the history of mathematics provided a more positive view of this discipline. It is a different and innovative concept of learning mathematical concepts, developing reasoning ability. In my opinion, it is necessary to invest in a qualified training of mathematics teachers, so that, within the classroom, they can end the stigma that mathematics is a “boogeyman”, so that throughout the school journey, students learn to really like this discipline. (St. 35)



## Conclusions

This study aims to understand how mathematical tasks with a historical context contribute to the learning of future mathematics teachers of the early years of schooling in terms of understanding mathematical concepts and their modes of representation, the nature of mathematics, the historical development of mathematical knowledge and the ability to appreciate this discipline and its social relevance. For this purpose, a formative experience was developed in which students were asked to reflect and learn mathematics, through HM and, in particular, to carry out historically contextualized mathematical tasks. The results allow us to conclude that students develop their knowledge of mathematics and become aware of the nature of mathematical knowledge. They understand the role that problem solving has played in the historical development and construction of mathematical concepts such as those taught in the early years of schooling, such as number, operation, regularity, and geometric objects, while understanding the relationships between them as well. In addition to the cognitive dimension of learning mathematics, within the scope of a contextualized and meaningful learning of mathematical concepts and the development of an understanding of what mathematics is and the processes by which it is created, the students developed an affective dimension, which led to a closer relationship with mathematics, whose appreciation was further enhanced. This appreciation also implied a recognition of the social relevance of mathematics, an aspect many students had not acknowledged before. Working on the HM as a way of learning mathematics and learning to know and appreciate it seems to be a need, especially for students who attend teacher training programs. A growing knowledge of mathematics implies being aware of its roots in History and society, which is why HM, through tasks and texts, seems to represent, in line with what is held by other authors (Jankvist et al., 2019; Pinto & Costa, 2020; Schubring et al., 2000), an interesting training opportunity for future teachers.

The main contribution of this study lies in the design of the formative experience which, in addition to the common link between History and Mathematics, establishes links with Philosophy of Mathematics, Sociology of Mathematics and Didactics of Mathematics itself (Fig. 2.1), that is, the historically contextualized tasks, with the support of historical texts, allowed forthcoming teachers to reflect on a subject that has been a part of their student life since they went to the school, and that in a few years they themselves will be teaching. In terms of continuity of this study, it may be interesting to understand how these future teachers, in addition to solving historically framed tasks, are able to design tasks for their future students. In this circumstance, the connection under analysis. in a historical context, is between Mathematics and Didactics of Mathematics.

## References

- Allan, G. (2020). Qualitative research. In I. G. Allan & C. Skinner (Eds.), *Handbook for research students in the social sciences* (pp. 177–189). Routledge.
- Ambrosio, U. (2006). *Ethnomathematics: Link between traditions and modernity*. Brill – Sense.
- Barbin, E., et al. (2018). *Let history into de mathematics classroom*. Springer.
- Clark, K. (2019). History and pedagogy of mathematics in mathematics education: History of the field, the potential of current examples, and directions for the future. In U. T. Jankvist, M. Heuvel-Panhuizen, & M. Veldhuis (Eds.), *Eleventh congress of the European Society for Research in mathematics education* (pp. 29–55). Utrecht University and ERME.
- Clark, K., Kjeldsen, T., Schorcht, S., & Tzanakis, C. (2016). History of mathematics in mathematics education: Recent developments. In L. Radford, F. Furinghetti, & T. Hausberger (Eds.), *Proceedings of the 2016 ICME satellite meeting of the international study group on the relations between the history and pedagogy of mathematics* (pp. 135–179). IREM.
- Cobb, P. (1994). Where is the mind? Constructivist and sociocultural perspectives on mathematical development. *Educational Researcher*, 23(7), 13–20.
- Erickson, F. (2012). Qualitative research methods for science education. In I. B. Fraser, K. Tobin, & C. McRobbie (Eds.), *Second international handbook of science education* (pp. 1451–1469). Springer.
- Heyd-Metzuyanim, E., & Sfard, A. (2012). Identity struggles in the mathematics classroom: On learning mathematics as an interplay of mathematizing and identifying. *International Journal of Educational Research*, 51, 128–145.
- Jankvist, U. T., Clark, K., & Mosvold, R. (2019). Developing mathematical knowledge for teaching teachers: Potentials of history of mathematics in teacher educator training. *Journal of Mathematics Teacher Education*, 23, 311–332.
- Katz, V. (2004). *The history of mathematics*. (Brief Edition). Person Education Inc.
- Lim, S. Y., & Chapman, E. (2015). Effects of using history as a tool to teach mathematics on students' attitudes, anxiety, motivation and achievement in grade 11 classrooms. *Educational Studies in Mathematics*, 90(2), 189–212.
- Martins, A. P., Clain, T., Ribeiro, A., Costa, C., Pinto, H., Gomes, H., & Menezes, L. (2021). Conceções e práticas de professores sobre a História no ensino da Matemática a num contexto de formação. *Millenium*, 2(8), 249–259.
- Menezes, L., Oliveira, H., & Canavarro, A. P. (2015). Inquiry-based mathematics teaching: The case of Célia. In U. Gellert, J. Gimenez Rodriguez, C. Hahn, & S. Kafoussi (Eds.), *Educational paths to mathematics* (pp. 305–321). Springer.
- Mosvold, R., Jakobsen, A., & Jankvist, U. T. (2014). What a mathematical knowledge for teaching may profit from the study of history of mathematics. *Science & Education*, 23, 47–60.
- Pinto, H., & Costa, C. (2020). La Historia de las Matemáticas en los Cursos de Educación Básica en Portugal: una Reflexión para la Formación del Profesorado. *Paradigma. Revista del centro de investigaciones educacionales*, 41(1), 1–19.
- Schubring, G., et al. (2000). History of mathematics for trainee teachers. In J. Fauvel & J. Van Maanen (Eds.), *History in mathematics education, the ICMI study* (pp. 91–142). Springer.
- Sfard, A. (2001). Learning mathematics as developing a discourse. In *Proceedings of 21st conference of PME-NA* (pp. 23–44).
- Siu, M. K. (2007). No, I don't use history of mathematics in my class. Why? In F. Furinghetti, S. Kaijser, & C. Tzanakis (Eds.), *Proceedings HPM2004 & ESU4* (pp. 268–277). Uppsala Universitet.
- Stein, M. K., Engle, R. A., Smith, M. S., & Hughes, E. K. (2008). Orchestrating productive mathematical discussions: Five practices for helping teachers move beyond show and tell. *Mathematical Thinking and Learning*, 10, 313–340.
- Weber, K., & Leikin, R. (2016). Recent advances in research on problem solving and problem posing. In A. Gutiérrez, G. Leder, & P. Boero (Eds.), *The second handbook of research on the psychology of mathematics education* (pp. 353–382). Springer.

# Chapter 3

## An Historic Approach to Modelling: Enriching High School Student's Capacities



Sixto Romero Sánchez

**Abstract** An active class can be enriched with fun and engaging activities that use the history of mathematics to deepen mathematical concepts. With this work it is intended, for future actions, that the history of mathematics can be used to teach them with different degrees of difficulty. And special attention to a proposal in the context of a research project with high school students (special school center), to explore the possibility of using the historical development of mathematics in a problematic and modeled teaching of mathematics that allows them to see if there is a relationship between cognitive processes and learning mathematics, when solving some tasks. Modeling in/with mathematics represents reaching out to our everyday actions that we perform in the environment around us. With this, we also mathematize culture through school and institutional actions, ultimately, social ones. In this work, as a fundamental nucleus, an activity centered on the exposition of two problematic situations related to the concept of conjecture and Diophantine equations, carried out in the context of a project called ERACIS (Estrategia Regional Andaluza para la Cohesión y la Inclusión Social), in the educational framework in Andalusia (Spain) is presented with secondary school students with special mathematical talent.

**Keywords** Mathematical modelling · Capacities · Talent · Conjectures · Proofs · Refutations · ERACIS project

---

S. R. Sánchez (✉)  
University of Huelva, Huelva, Spain  
e-mail: [sixto@uhu.es](mailto:sixto@uhu.es)

## Introduction

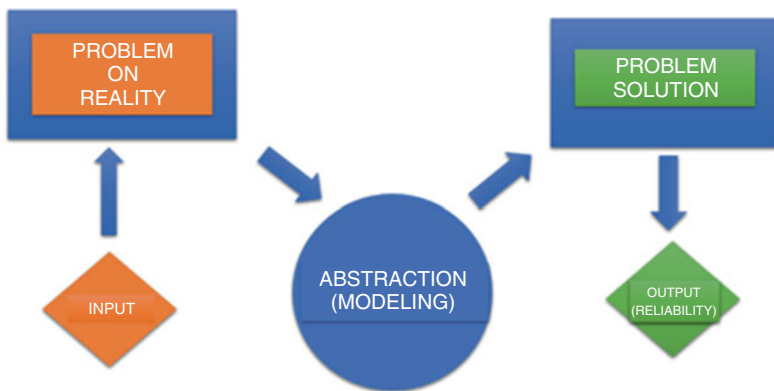
In the teaching of traditional mathematics there has been an epistemological subject-object relationship between teacher and student. This fact is closely related to educational policies and how the teacher conceives mathematics and uses education as an exercise of power (Rodríguez & Mosqueda, 2015).

In relation to this, highlight the Brazilian Paulo Reglus Neves Freire (1921–1997), a prominent defender of critical pedagogy, one of the greatest and most significant pedagogues of the twentieth century. With the beginning of his dialogue, he taught a new way for the relationship between teachers and students. His ideas influenced and influence democratic processes around the world: "... Teaching is not transferring knowledge, but creating possibilities for its own production or construction. ..." (Freire, 1997, 2000).

I agree with the researchers Rodríguez and Mosqueda (2015) in pointing out that the Freirean dialogue is one of its essential principles, which enables communication and places the actors in the educational process of mathematics on a horizontal plane, as opposed to the authoritarian education of traditional pedagogy of mathematics: "... Liberating education proposes relationships between equals and a permanent dialogue that facilitates the learning of both the student and the educator; it is there where the educator becomes an educated and the educated becomes an educator. ...".

In Freire's conception, the learner should not be considered as an empty container that must be filled with knowledge. In his position, the educator and the learner must face together the act of knowing. And this facing together is done from a position of "learning partners", from a horizontal situation and not from a vertical position in which the teacher communicates to a student that he does not know. The Freirian vision postulates a dialogue teaching, which stimulates creativity and critical awareness. (Meza, 2009).

Hans Freudenthal, for his part, in 1983 questioned himself: How to create adequate contexts to be able to teach by mathematizing? His response: "...we need math problems that have meaningful context for students. *The History of Mathematics offers multiple examples that can be used, in the classroom, through a methodology very close to problem solving and at the same time serve as an example of how mathematics organizes everyday phenomena...*". Freudenthal advocates a mathematical activity or active mathematics as the basis of teaching. Such a way of understanding mathematics has a fundamental characteristic called mathematization (Freudenthal, 1983) which consists of organizing and structuring the information that appears in a problem, identifying mathematical aspects and discovering regularities, relationships and structures. The experimentation of the phenomena by the students allows the appearance of particular solutions and conceptions. The teacher's task, consistent with the principle, should be to advance from those particular solutions and conceptions to the most elaborate ones in mathematics. Thus arises the disquisition of Treffers (1987) on horizontal and vertical mathematics. In the mathematization process, domain of the phenomenon through mathematical



**Fig. 3.1** Scheme for modeling (Romero et al., 2014)

tools, a dichotomy is established between the horizontal and vertical mathematical processes (Gravemeijer, 1994; Menon, 2013).

Horizontal mathematics takes us from the real world to the world of symbols and enables the mathematical treatment of problems. Once the problem has been formulated in mathematical terms, the activity becomes specifically mathematical, this is what is called vertical mathematics.

Research in Mathematics Education has focused, for a long time, its attention on the design of activities, based on mathematical modeling, of real situations with the conviction of obtaining a greater guarantee in the gain, by our students, of mathematical learning, and therefore in teaching by teachers (Romero et al., 2014) (Fig. 3.1).

One of the most complex problems that education faces at different educational levels, as far as the teaching of mathematics is concerned, is related to the way of articulating the contents with other areas of knowledge and even with mathematics itself. That is, most of the content organized into topics is disconnected from the real world and science, which has the consequence that our students do not conceive the usefulness of mathematics in their training. As indicated above, in recent years, research in Mathematics Education shows that one of the issues that has attracted attention is the design of activities based on the modeling of real situations. In many countries, and under different conditions, its inclusion in the curriculum has made it possible to develop cognitive, metacognitive, and transversal skills that help to understand the role of mathematics in today's society (De Lange et al., 1993; Keitel et al., 1993; Blomhøj, 2000; Aravena, 2001; Aravena & Caamaño, 2007). For this reason, today's society must be endowed with the role of facing problem solving, making estimates, making decisions, facing a mathematization of the culture and the environment that surrounds it, that is, modeling from the Mathematics is to tend to favor the understanding of concepts and methods, thus allowing a more complete and global vision of mathematics (Guzman, 1994).

Throughout history, mathematics has occupied a predominant place in school curricula. They have achieved this prominence not so much for the importance they have in themselves as for cultural and social reasons. Such is the importance achieved that it is taught in practically all schools in the world.

As an introduction, one of the objectives of the work presented is that the study of the history of mathematics can be a tool for gifted students participating in the ERACIS project, which we present *ut-infra*, to develop, among others, the processes of conjecture, proof and refutation and the contextualization of the Diophantine equations. For this, a theoretical framework is used that analyzes the historical problems of evolution of the knowledge of the square root and the Diophantine equations within a larger framework that is the model and mathematical modeling. And, in turn, mathematical modeling is used as a theoretical framework for the modeling of teaching practice in gifted students participating in said project.

## **Use of the History of Mathematics in a Problematic and Modeled Teaching of Mathematics**

There are some contributions of historical reflection that are of particular interest to teachers in their reflections on teaching. The study of the mathematical processes of construction, generally hidden in an exclusively formal presentation or in the school presentation, provides conceptual, methodological and epistemological elements that the teacher can use in their educational proposals (Anacona, 2003. p. 37). We can mention, among others, the following:

- The History of mathematics as an element in the development of a curriculum.
- The History of Mathematics in the design of didactic activities, for example, the use of historical texts, is very attractive to students, who are surprised by the techniques, symbols and languages used, thus expanding their panorama of problem solving (Barbin, 1996; Barbin et al., 1996; García, 2008).
- Historical-epistemological studies as vehicles of knowledge that account for the genesis, evolution and consolidation of a mathematical concept within the framework of socio-cultural conditions, contribute to an understanding of the mathematical concept that transcends mere algorithmic processes (Arboleda, 1983).
- The History of Mathematics, as a communication bridge between mathematics and culture, offers the possibility of showing the links that exist between mathematics as a historical construction and other cultural productions of humanity.
- The History of Mathematics offers a rich source of problems that can be the subject of different treatments such as playful treatment. Different moments and great theoretical problems, which occupied an important place in history, can be converted into recreational mathematics activities, in which the game and all its pedagogical components occupy a central place (Anacona, 2003. p.43)

## ***Reflection on Problem Solving as a Way to Mathematical Modelling***

The subsequent presentation of several examples on mathematical modelling, illustrating different levels of complexity, may appear in the mathematization process in which the theoretical framework that globally bases each of the steps taken, the approaches adopted or the results obtained becomes explicit.

Modeling mathematically means that the development of the examples also reveals the connections between problem solving and the process of creation and discovery in mathematics; In short, achieving the discovery or creation of models and theories is one of the objectives.

As for the role that the student assumes in the process, it is similar to that of a mathematician in the development of an investigation, there is only one difference: the level of knowledge with which one works (high school, high school and even University).

The author of this work is aware of the difficulty involved in dealing with this topic at certain levels of education, but I would like to formulate and substantiate some ideas to justify the concept of modeling:

- What aspects of the creation and/or discovery process in Mathematics should we focus on so that when they are brought to the classroom we can achieve the educational objectives that we have set for ourselves?
- Can we in secondary or high school education, with students of these ages, experience the process using some ideas about it as a theoretical framework together with problem-solving models?

On the other hand, when considering bringing the subject to the classroom, we must make explicit the didactic objectives that we are going to consider. In our case, among others, mention the following:

- Deepen the methods of research in mathematics: particularization, the search for general laws, the construction of models, generalization, the use of analogies, conjectures and demonstrations.
- Use mathematical models to mathematize reality and solve problems, experiencing their validity and usefulness, criticizing their limitations, improving them and communicating their results and conclusions.
- Practice problem solving as the most genuine activity in any specific field of mathematics.
- Bringing students closer to mathematical knowledge, prioritizing the approach and resolution of challenges, the search for explanatory models, inquiry and discovery.
- Encourage students to see the true face of mathematics, through the history of this discipline, often assuming the role of a research mathematician.

- Prepare our students for the invention, increasing the taste for it. Increase the mathematical culture of our students, discarding erroneous beliefs about the nature of knowledge and mathematical work throughout history and its results.

These didactic approaches must be accompanied by a personal reflection on the main ideas that can help us situate ourselves in each moment or explain, in a coherent way, the type of situations that are happening or that we are encountering.

When faced with the questions, why is mathematics essential today? Why is it necessary to renew its teaching? How should the content of the programs and teaching methods be redefined? What should be the priorities for Tomorrow? Can we and should we strengthen the link between mathematics and other disciplines? In what direction should the training of mathematics teachers evolve? (Kahane, 2002), it is necessary to pay attention when Kahane states: “. . . reflection on the teaching of mathematics must be carried out from all angles, from all statuses: it can be from the daily task in the classroom, of the difficulties of teachers and students of all educational levels. It can be done, through a detailed study of the exams, of the tests; or extracurricular activities, gymkhanas, rallies, competitions, Olympics, in short, all the manifestations of animation and dissemination of mathematics; or the role and evolution of mathematical sciences in the sciences and society as a whole. . .”. As in France, in our country, teachers grouped, or not, in Societies of Teachers, Editors of Reviews of Mathematic Education... (for example, the Spanish Federation of Mathematics Teachers’ Societies, FESPM, MSEL (Modeling in Science Education and Learning, among others) have taken initiatives in order to make proposals and initiatives in the field of modeling mathematics and that lead to an improvement of the binomial Teaching/Learning of Mathematics.

Problems have a long tradition in mathematics. George Polya viewed Euclid’s Elements as a collection of problems (a succession of statements and solutions). Together with Gabor Szegő he produced under the title of Problems and Theorems in Analysis I (Polya and Szego, Polya & Szego, 1972), a graduated collection of problems that were, without a doubt, in their time, the best introduction to mathematical analysis, and that has remained as a jewel of great interest that deserves to be studied.

The scientific approaches and attitudes that are expected, satisfy the general and specific objectives of the teaching of mathematics, as well as the “a priori” “known” knowledge, for its organization, must be in accordance with the depth defined by the level of class and by the pace adopted by some students. And as a result, the same content can be taught or “repeated” several times, but at different levels with corresponding adjustments.

We teachers must reflect, to a greater or lesser extent, on the role of the history of mathematics in its attention to diversity. The value of historical knowledge does not consist in having an accumulation of curious stories to entertain our students in order to make a stop along the way; on the contrary, history can and should be used, for example, to understand and make a difficult idea understood in the most appropriate way. The history of mathematics should be a powerful aid for the fulfillment of the



objectives proposed in our educational work, and even more so in special educational environments of diversity, such as:

- Make clear the way ideas appear in mathematics.
- Temporally and spatially frame big ideas and problems, along with their motivation, precedents, etc.
- Point out the open problems of each era, their evolution, the current situation.
- Point out the historical relations of mathematics with other sciences, in whose interaction a large number of important ideas have traditionally arisen.

With a greater or lesser degree of mathematization, we present below some considerations and the study of some cases, with the conviction of the need to confront at present a problematized and modeled teaching of mathematics (Romero, 2011; Romero & Romero, 2015).

### **Problematic that Can Be Posed: Study of Cases**

For not many years, researchers in Mathematics Education have focused their attention on the design of activities based on the mathematical modeling of real situations with the conviction of obtaining a greater guarantee in the gain, by our students, of mathematical learning, and therefore in the teaching by the teachers.

We present below, with some details, an activity that indicates, a priori, the level at which it seems to us that certain proposed exercises can be tackled. However, this indication is given only as a guide since it depends, of course, on the contents of the programs, the level of the class and the choices that the teacher considers appropriate to achieve their objectives. In this way we recommend that for other similar exercises the level of presentation is not indicated, due to its greater difficulty for the students. Naturally, considering that being, for example, at a secondary education level, it should be the teacher who considers it appropriate if they are going to teach students who have chosen the option traditionally called the “social option” as opposed to the “scientific option”, as outlined in the following paragraph (ERACIS).

It is possible to work from different perspectives in different case studies, among others, in reference to methodological objectives (MO) and content (C).

### ***Problematic (MO): Conjectures, Proofs and Refutations***

By conjecture is meant the judgment that is formed (moral, ethical or mathematical) of things or events by evidence and observations. In mathematics, the concept of conjecture refers to a statement or hypothesis that is supposed to be true, but has not been proven or disproved. Once the truth of a conjecture is proven, it is considered a full-fledged theorem and can be used as such to build other formal proofs.

Perhaps contrary to the definition that has been given of ut-supra conjecture, in mathematics we distinguish between proof and proof: the mathematical proof is a particular proof, respecting the codified and commonly accepted rules and rhetoric, although there are different forms of proof: the physical proof or the “exposition” where it is enough to put in evidence a fact or an example.

In this way we provoke in the student the need to study the concept of conjecture.

In relation to some brushstrokes in relation to history: in the history of science, and in particular of mathematics, problems are always being posed – the history of mathematics arises from the relationship between human beings and nature – and many of them are posed simply for the sake of posing them. Some appear when a previous problem is being solved or has been solved, and many others arise from certain situations or observations that lead to a problem model, the solution of which is in many cases one more step forward in the history of science and of humanity. In many cases, these problems that are proposed to us are easily solved by someone. In other cases, finding the solution was tremendously complicated or difficult. So much so that it took centuries to reach it. And there are problems of which nothing is known yet. The way to know if they are true or false has not yet arrived. To solve a problem of this type you have to look for a consistent proof, if true; or come up with a counterexample if it is false.

In mathematics, the concept of conjecture refers to a statement or proposition that is assumed to be true, but has not been proven or disproved to date. Once a conjecture is proven to be true, it is considered a fully-fledged theorem and can be used as such to construct other formal proofs. As in other sciences, guesswork has always played a stimulating role in mathematics as well. M. Atiyah (2000) said in his collaboration on the book *Mathematics: Frontiers and Perspectives*: “*Some problems open doors, some problems close doors, and some remain curiosities, but all sharpen our ingenuity and act as a challenge and a test of our ingenuity and our techniques*” (sic).

A brief comment on some conjectures, such as the Riemann hypothesis (still a conjecture) or Fermat’s Last Theorem (a conjecture until Andrew Wiles proved it in Wiles, 1995), that have shaped much of mathematical history as new areas of mathematics that is developed in order to demonstrate it. Until recently the best-known conjecture was Fermat’s last theorem, misnamed because, although Pierre de Fermat claimed to have found a proof, none could be found among his writings after his death. This conjecture scoffed at the mathematical community for more than three centuries until Wiles, A. finally elevated it to the rank of a theorem.

On the other hand, the mathematical challenge that anyone understands, but nobody has solved: Goldbach’s conjecture. In more than three hundred years, no one has been able to prove this conjecture, one of the simplest and at the same time most complex problems in all of mathematics.

What happens in this type of problem and again we wonder how the student will address it at their level of training as a student?

The activities related to this topic can lead to the student’s personal reflection, to doubt, to make assumptions, to be convinced of the truth of the exposed statements or of the properties that can be deduced, if they work collectively. This joint work

must help to find solutions, but it also has a social aspect where it exists: the need to convince whether the decision taken is true or false, the need to communicate objectively, as well as to take into account the subjectivity of a leader, as a spokesperson who communicates the exchanges during the process of solving the problem.

## ***ERACIS Project***

### **Experience with Secondary School Students in an ERACIS Center, in Time of the COVID 19 Pandemic**

We present, below, the experience carried out in a secondary school class in a center in Huelva (Spain) in the context of the project called, Management of mathematical talent in times of uncertainty-COVID19- in students of Compulsory Secondary Education in a center ERACIS (Estrategia Regional Andaluza para la Cohesión e Inclusión Social- Andalusian Regional Strategy for Cohesion and Social Inclusion) (Romero & Benítez, 2021a, 2022 and Romero & Benítez, 2021b, 2022). To do this, work will be done on challenges and trends in talent management in times of uncertainty, such as the current one with the presence of COVID19.

The experience was carried out, initially, with 25 third and fourth year secondary school students (15–16 years old) of which 13 participated in a Learning and Improvement Program considered troublesome students. Different activities were scheduled taking into account, among others, the historical development of the following topics:

1. The importance of prime numbers
2. From Chaos to Security
3. Cryptography.
4. Curious numbers
5. Experimental mathematics with modeling activities in the teaching of mathematics through historical problems posed and/or solved by Galileo Galilei, François Vehrult, Edwards Lorentz,...
6. Elementary mathematics from a higher point of view:
  - Fibonacci Sequence: Examples.
  - Golden Number
  - Matrices in Genetics and Mendel's Laws
  - Mathematical modeling of the evolution of chemical reagents
  - Number “e”. Applications
  - Fractals in nature
  - Rare Areas. Geogebra.
  - Dynamic Systems: evolution of the species

## 7. Calculation of square roots of large numbers

## 8. Diophantine Equations

But we were not successful with these students, who disassociated themselves from the activity, but we did succeed with 13 fourth-year secondary school students (15–16 years old) who constitute the central nucleus of our work.

The following lines shows an outline of the topics of the regulated training of the participating students:

(a) 5 students in Academic Mathematics, oriented to teachings in which both theoretical aspects and practical applications are strengthened and more difficult activities may be proposed. They are aimed at achieving the necessary skills to study Baccalaureate of Sciences or Social Sciences. Academic Mathematics deals with a greater number of contents and of greater difficulty and Applied Mathematics is more basic. The syllabus of the subject is grouped into a series of blocks that group the different units that make up the subject program:

- Algebra
- Geometry
- Features
- Combinatorics
- Probability

(b) 8 students in Applied Mathematics, oriented to Applied Teaching, emphasis is placed on the practical application of the course contents as opposed to deepening the theoretical aspects to achieve the necessary skills to study Vocational Training or a Baccalaureate modality that does not have Math. The syllabus is grouped around several didactic blocks that address the complete syllabus of the subject.

- Calculation
- Algebra
- Geometry
- Features
- Statistics

Of the 13 students with an initial test carried out to obtain information on their mathematical culture, only five of different nationalities passed the required level: Morocco, Algeria, Romania, Spain. And with them we have been working in the 2021–2022 academic year on the aforementioned topics (Fig. 3.2, 3.3 and 3.4).

As a summary, we propose the resolution of a list of problematic situations, among which we present ut-infra: find the square root of a large number equation.

It is a proposal to the student to explore the possibility of using historical development that allows him to see if there is a relationship between cognitive processes and learning mathematics, when solving the task of calculating the square root of large numbers.

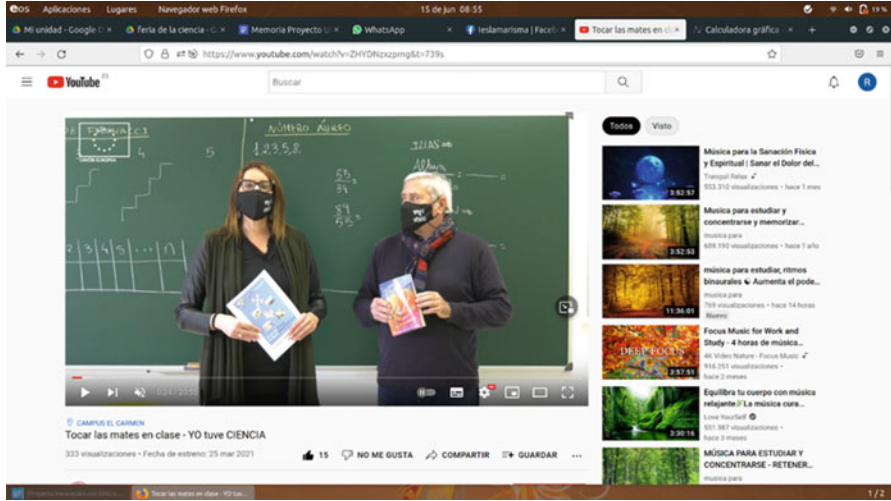


Fig. 3.2 ERACIS Project teachers



Fig. 3.3 Students of the ERACIS project at the Science Fair in Seville (May 2022) (I)

In this exploration we show them that they must investigate how square roots are mathematical expressions that arose when posing various geometric problems such as the length of the diagonal of a square. The Ahmes Papyrus dated to 1650 BC. C. shows how the Egyptians extracted square roots (Anglin, 1994). In ancient India, knowledge of the theoretical and applied aspects of the square and the square root was at least as old as the Sulba Sutras, dated around 800–500 BC. C (Gheverghese, 2000) whose importance lies in the fact that they constitute the only surviving source on the basic mathematical knowledge that was known in India during the Vedic period (prior to the formation of the Hindu religion). The Babylonians approximated square roots by calculating using the arithmetic mean. On the other hand, square roots were one of the first developments in mathematics, being particularly investigated during the Pythagorean period, when the discovery that the square root of 2 was irrational (incommensurable) or not expressible as any



Fig. 3.4 Students of the ERACIS project at the Science Fair in Seville (May 2022) (I)

quotient, which meant a milestone in the mathematics of the time. Subsequently, the definition of square root was expanded. For negative real numbers, the generalization of their square root function gives rise to the concept of imaginary numbers and the field of complex numbers, something necessary for any polynomial to have all its roots (fundamental theorem of algebra). The square root symbol was introduced in 1525 by the mathematician Christoph Rudolff (Cajori, 2007; Suzuki, 2009) to represent this operation that appears in his book *Coss* being the first algebra treatise written in vulgar German.

We present examples with a methodological approach for the use of original sources in the classroom. The creation of a mathematics learning environment that reflects on inquiry is a significant element of this methodology. It functions as a mediating link between the theoretical analysis of sources from the past and a classroom practice where students are invited to the workplace of mathematicians from the past through history.

### *Application Examples*

**Example 3.1: Curious Exercise for Calculating Squares of Large Numbers**  
*As the following case, find the square root of*

$$\sqrt{(1111111111\dots\dots\dots1111).(1000000000\dots\dots\dots0005) + 1}$$

Let's fix our attention on the numbers

$$4, 34, 334, 3334, \dots, 3333333 \dots 33334, \dots$$

represent a sequence whose squares are

$$16, 1156, 111556, 11115556, 1111155556, \dots, 11111 \dots 15555 \dots 5556, \dots$$

An interesting exercise that we will solve through the concept of conjecture

It has to:

- $\sqrt{1x15} = 4$
- $\sqrt{11x105 + 1} = 34$
- $\sqrt{111x1005 + 1} = 334$
- $\sqrt{1111x1005 + 1} = 3334$

What will be the value of

$$\sqrt{11111x100005 + 1}?$$

What kinds of conjectures can be cast? Can they be tested?

Calculate, then:

- $\sqrt{1111111111x1000000005 + 1} = ?$
- $\sqrt{(1111111111 \dots 1111) \cdot (1000000000 \dots 0005) + 1}$

### Note and Indication

This exercise consists of calculating the square root of a number using the definition of conjecture. It is designed to remember the meaning of a number written in the decimal system and to promote and activate the student's curiosity so that it fits more easily in the test of the particularity of the given numbers. For this, several sequences of numbers will be considered and one of the keys to move from the definition to the understanding of the term of range "n" of these sequences to its expression as a function of "n".

- a) In the successive roots, let us pay attention to the first factors that we can decompose into the sequences,  $P$ , of numbers writing only with "1"

$$P_1 = 1; P_2 = 11; P_3 = 111, \dots, P_n = 111111 \dots 1111$$

$$P_1 = 1; P_2 = 10 + 1; P_3 = 100 + 10 + 1; \dots, P_n = 10^{n-1} + 10^{n-2} + \dots + 10 + 1$$

which we can write like this:

$$P_1 = 1; P_2 = 10 + 1; P_3 = 100 + 10 + 1, \dots, P_n = \frac{10^n - 1}{9}$$

b) Also, the second factors, we can also write as the sequence  $Q$  of integers such that:

$$\begin{aligned} Q_1 &= 15; Q_2 = 105; Q_3 = 1005, \dots, Q_n = 1000000000 \dots^{n-1} \dots 005 \\ Q_1 &= 10 + 5; Q_2 = 100 + 5; Q_3 = 1000 + 5; \dots, \\ Q_n &= 1000000000 \dots^{n-1} \dots 00 + 5 \end{aligned}$$

which we can write like this:

$$Q_1 = 10 + 5; Q_2 = 10^2 + 5; Q_3 = 10^3 + 5; \dots, Q_n = 10^n + 5$$

c) The sequence  $H$  of integers numbers of the radical satisfies

$$\forall n \in N^*$$

$H_n = P_n \cdot Q_n + 1$  is equal to

$$\frac{10^n - 1}{9} (10^n + 5) + 1 = \frac{10^{2n} + 4 \cdot 10^n + 4}{9} = \left( \frac{10^n + 2}{3} \right)^2$$

Where

$$\forall n \in N^* : \left( \sqrt{M_n L_n + 1} \right) = \frac{10^n + 2}{3}; \forall n \in N^* : \sqrt{H_n} = \frac{10^n + 2}{3}$$

Can we ensure that it is an integer?

Indeed, decomposing the numerator we have:

$$\frac{10^n + 2}{3} = \frac{10^n + 3 - 1}{3} = \frac{10^n - 1}{3} + 1 = 3P_n + 1$$

With all this it can be conjectured that the square root of the large number



$$\sqrt{1111111111.10000000005 + 1} \text{ is } 3.333.333.334$$

That generically leads us to affirm that

$$\begin{aligned} &\sqrt{(1111111111\dots\dots1111)x(1000000000\dots\dots0005 + 1)} \\ &= 3.333\dots\dots333.334 \end{aligned}$$

**Note:** It is suggested to the students that with analogous reasoning they study the sequence

$$7, 67, 667, 6667, 66667, \dots$$

which has the same structure, that the case studied ut-supra, but now is

$$\begin{aligned} &\sqrt{(44 + 4) + 1} = 7 \\ &\sqrt{(4444 + 44) + 1} = 67 \\ &\sqrt{(444444 + 444) + 1} = 667 \\ &\dots\dots \end{aligned}$$

We can conjecture that

$$\sqrt{\left(44\dots44 + 4\dots4 + 1 = 66\dots67\right)^{n-1}}$$

The students of the ERACIS Project, under the supervision of the responsible professors, are motivated by their interest in research and collaborative work by offering them bibliographies, in the case at hand, related to Goldbach's conjecture in its relationship with Leonard Euler. The following lines are those found by the group of four students with whom we continue to work on the project. As a summary, the lines that follow represent the result of the collaborative work.

*“... In a letter to Euler and dated June 7, 1742, Christian Goldbach (1690–1764) claimed to have observed that any even number greater than 2 could be written as the sum of two primes; and that every odd number greater than 5 could be represented as a sum of three.*

*One hundred sixty-seven letters from the Euler-Goldbach correspondence were published (Fuss, 1843) in his Correspondance mathématique et physique de quelques célèbres géomètres du XVIIIème siècle. The letters below all came from Fuss' book. Unfortunately, Fuss often excised the personal part of the correspondence, and published only the scientific material. From page 144 of Fuss's text, the correspondence between Euler and Goldbach appears, with letter XLIII (pp-280) showing the correspondence between them on the conjecture with details...”.*

The resolution of Goldbach’s conjecture is considered one of the most difficult problems in mathematics (Cilleruelo, 2000).

We have that the following even numbers adopt the following decomposition

- 4 = 2 + 2; 6 = 3 + 3; 8 = 3+5; 10 = 3 + 7 = 5 + 5; 12 = 5 + 7; 14 = 3 + 11 = 7 + 7;
- 16 = 3 + 13 = 5 + 11; 18 = 5 + 13 = 7 + 11; 20 = 3 + 17 = 7 + 13
- 22 = 3 + 19 = 5 + 17 = 11 + 11; .....

The conjecture has been verified for all even numbers less than  $4 \times 10^{14}$  verified in 2000 and published in 2001 by Joerg Richstein (Richstein, 2001): “...Using a carefully optimized segmented sieve and an efficient checking algorithm, the Goldbach conjecture has been verified and is now known to be true up to  $4.10^{14}$ . The program was distributed to various workstations. It kept track of maximal values of the smaller prime in the minimal partition of the even numbers, where a minimal partition is a representation  $2n = p + q$  with  $2n - p$  being composite for all  $p' < p$ . The maximal prime  $p$  needed in the considered interval was found to be 5569 and is needed for the partition  $389965026819938 = 5569 + 389965026814369..$ ”.

It can be seen in the previous list how the first even numbers are not only representable as the sum of two primes, but the number of representations of n as the sum of two primes seems to grow with n. This is due, among other things, to the fact that the cousins are quite numerous (Figs. 3.5, 3.6 and 3.7).

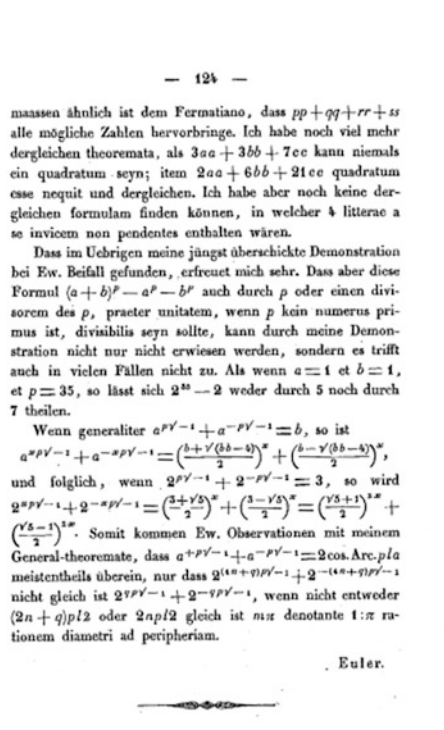


Fig. 3.5 Lettre XLIII-Christian Goldbach a Euler

— 126 —

so dass, wenn die formula ipsa = 2 ist, die applicata maxima unten oder oben herauskommt, folglich unzählige andere applicatae unter sich gleich seyn müssen; nichts desto weniger ist in meiner damaligen Expression ein Fehler eingeschlichen, den Ew. mit Recht angemerkt haben, und leicht verbessert werden kann, indem es heissen sollen, dass wenn  $q$  ein numerus quicunque und  $2^{p^q-1} + 2^{-p^q-1} = 0$  gesetzt wird, alsdann positio pro  $n$  integro quocunque, seyn werde

$$2^{(2^n-1-q)p^q-1} + 2^{-(2^n-1-q)p^q-1} = 2^{q p^q-1} + 2^{-q p^q-1}$$

Ew. haben gefunden, dass alle Zahlen, so nicht  $\frac{1}{2}mn - m - n$  seyn können, in dieser Formel begriffen sind  $v^2 + v + u^2$ , und ich finde, dass alle  $\frac{1}{2}mn - m - n$  zu dieser Formel  $y^2 + y - x^2$  gebracht werden können, so dass eine jede gegebene Zahl gleich ist  $p^2 + p \pm q^2$ , woselbst  $p$  et  $q$  numeros integros anzeigen, oder auch eine von beiden litteris 0 bedeuten kann; woraus zu sehen ist, dass eine jede Zahl aus einem duplo numeri triangularis  $\pm$  numero quadrato besteht. Weil aber auch eine jede Zahl gleich ist der Formel

$$u^2 + v^2 + v + y^2 + y - x^2,$$

so wird, wenn man setzt  $u = \frac{v^2+s}{4} + 1$ ,  $x = \frac{v^2+s}{4} - 1$ ,  $u^2 - x^2 = s^2 + s$ , folglich jedes numeri dati dimidium

$$\frac{s}{2} = \frac{v^2+s+y^2+y+s^2+s}{2},$$

id est tribus trigonalibus.

Dass in der formula polygonalium  $\frac{(p-2)s^2 - (p-4)s}{2}$ , wenn sie gleich werden soll  $\frac{1}{2}mn - m - n$ ,  $p$  weder  $5 \pm 2$  noch  $5 \pm 1$  seyn könne, sondern alle trigonales, tetragonales, hexagonales und heptagonales ausgeschlossen werden, folget ex istdem principiis.

— 127 —

Ich halte es nicht für undienlich, dass man auch diejenigen propositiones anmerke, welche sehr probabiles sind, obgleich es an einer wirklichen Demonstration fehlet, denn wenn sie auch nachmals falsch befunden werden, so können sie doch zu Entdeckung einer neuen Wahrheit Gelegenheit geben. Des Fermati Einfall, dass jeder numerus  $2^{2^n-1} + 1$  eine seriem numerorum primorum gebe, kann zwar, wie Ew. bereits gezeigt haben, nicht bestehen; es wäre aber schon was Sonderliches, wenn diese series lauter numeros unico modo in duo quadrata divisibiles gäbe. Auf solche Weise will ich auch eine conjecture hazardiren: dass jede Zahl, welche aus zweyen numeris primis zusammengesetzt ist, ein aggregatum so vieler numerorum primorum sey, als man will (die unitatem mit dazu gerechnet), bis auf die congruam omnium unitatum \*); zum Exempel

$$4 = \begin{cases} 1+3 \\ 1+1+2 \\ 1+1+1+1 \end{cases} \quad 5 = \begin{cases} 2+3 \\ 1+1+3 \\ 1+1+1+2 \\ 1+1+1+1+1 \end{cases}$$

$$6 = \begin{cases} 1+5 \\ 1+2+3 \\ 1+1+1+3 \\ 1+1+1+1+2 \\ 1+1+1+1+1+1 \end{cases} \text{ etc.}$$

\*) Nachdem ich dieses wieder durchgesehen, finde ich, dass sich die conjecture in summo rigore demonstrare lässt in casu  $n+1$ , si successit in casu  $n$ , et  $n+1$  dividit posit in duo numeros primos. Die Demonstration ist sehr leicht. Es scheint wenigstens, dass eine jede Zahl, die größer ist als 1, ein aggregatam trium numerorum primorum sey. G

Fig. 3.6 Lettre XLIII-Christian Goldbach a Euler

Regarding conjectures in mathematics there is, depending on the mathematician's specialty, the opinion of classifying them by importance is a personal matter (Sáenz, 2001; Hiriart-Urruty, 2011) depending on whether the conjecture is stated in the domain that is worked on. Some will be considered very important and others not, or of little interest by mathematicians and specialists in a different domain. These are some of the most famous guesses:

- Goldbach's conjecture
- Collatz conjecture
- Riemann hypothesis
- $P \neq NP$
- Poincaré conjecture (proved by Grigori Perelman in 2002)

Following Hiriart-Urruty (2011), a famous conjecture must verify the following three properties:

- The statement is simple, understandable to most mathematicians, and even non-mathematicians. (The P. Fermat conjecture, until its proof by A. Wiles and R. Taylor in 1994, was a clear example of perfection).

Hierauf folgen ein Paar observationes, so demonstrirct werden können:

Si  $v$  sit functio ipsius  $x$  ejusmodi, ut facta  $v = c$  numero cuicumque, determinari possit  $x$  per  $c$  et reliquis constantes in functione expressas, poterit etiam determinari valor ipsius  $x$  in aequatione  $v^{2v+1} = (2v+1)(v+1)^{v-1}$ .

*Note marginale d'Euler:*

$$\begin{aligned} v^{2v+1} - (v+1)(v+1)^{v-1} & \text{ divisib. per } vv - v - 1 \\ \text{addatur } (v - v - 1)(v+1)^{v-1} & \\ v^{2v+1} - (2v+1)(v+1)^{v-1} & \text{ divisib. per } vv - v - 1. \end{aligned}$$

Si concipiatur curva cujus abscissa sit  $x$ , applicata vero sit summa seriei  $\frac{x^n}{n \cdot 2^{2n}}$ , posita  $n$  pro exponente terminorum hoc est, applicata  $= \frac{x}{1 \cdot 2^2} + \frac{x^2}{2 \cdot 2^4} + \frac{x^3}{3 \cdot 2^6} + \frac{x^4}{4 \cdot 2^8} + \text{etc.}$ , dico, si fuerit abscissa  $=$

$$\begin{aligned} 1, & \text{ applicatam fore } = \frac{1}{3} \left\{ \begin{array}{l} \text{en } \frac{1}{3}, \text{ nam sit haec applicata } = y, \\ \text{erit } y = t \cdot \frac{1}{4-x} \text{ Note marginale d'Euler} \end{array} \right\} \\ 2 & \dots \dots \dots 1/2 \\ 3 & \dots \dots \dots 2/2 \\ 4 & \text{ vel major } \dots \dots \text{ infinitam.} \end{aligned}$$

Goldbach.

*P. S.* Die beiden andern formulas numerorum non quadratorum, deren Erwähnung thun, habe ich noch nicht untersucht, ich glaube aber, dass selbige, wenn man setzt

$$a = hx + k, \quad b = lx + m, \quad c = nx + p$$

sich wohl möchten unter nachfolgende Formeln rangiren lassen, allwo  $f, g, \gamma, \delta$  numeri integri affirmativi sind

$$(2f - 4\gamma\delta)x^2 + 4(f - 2\gamma\delta)(2g - \delta^2)x + (2g - \delta^2)^2 - 4\gamma^2 \quad \dots \quad - 2f \quad \dots \quad - 2g$$

denn diese kann niemals ein quadratum geben. . . .

Posita  $m$  et  $p$  numeris integris affirmativis, haec expressio  $\frac{p+2 \pm \sqrt{(3p-m+5)}}{m}$  non potest fieri numerus integer.



Fig. 3.7 Lettre XLIII-Christian Goldbach a Euler

- Having long resisted the assaults of professional mathematicians.
- To have generated mathematical novelties through the different attempts at solutions. In conclusion, it is necessary to weigh and emphasize the importance of the development of reasoning in the learning of Mathematics. Students must be clear that it has a meaning that must be rebuilt through the development of ideas, justification of results and the use of conjectures, among other activities.

### Problematic (C): In Reference to Content

In this section we are not going to detail the solutions for obvious reasons of space, but it is interesting to highlight in reference to the contents that we can work with the students situations of: location and detection, study of certain configurations, representations and associated measures, dynamics of points, figures and numbers, measurement of large and small quantities, treatment and representation of statistical data, etc. ...

**Example 3.2: Vessels Problem**

*There are two vessels of 3 and 5 liters respectively. These vessels are near a fountain and it is necessary to measure exactly 4 liters of water. How would it be done?*

This problematic situation, classic and studied by Niccolò Fontana Tartaglia in the sixteenth century, presents a playful nature that can motivate students. Niccolò Fontana (1500-December 13, 1557), a mathematician nicknamed Tartaglia (the stutterer) since as a child he received a wound in the taking of his hometown, Brescia, by Gaston de Foix Huérfano and without material means to provide himself with an instruction, arrived to be one of the leading mathematicians of the sixteenth century.

He taught and explained this science successively in Verona, Vinezza, Brescia and finally Venice, the city in which he died in 1557 in the same poverty that accompanied him all his life. Tartaglia (1500–1557) is said to have only learned half of the alphabet from a private tutor before the money ran out, and subsequently had to learn the rest on his own. Be that as it may, his learning was essentially self-taught.

**Note and Indication** With this example we intend to show that interactive activities can be promoted to take to the classroom based on some scenes from a movie, trying to promote a taste for Mathematics through cinema. Reference is made to the methodological proposal of how to adapt a historical problem to the current context, and use cinema, to present it to ERACIS students in order for them to solve a Diophantine equation.

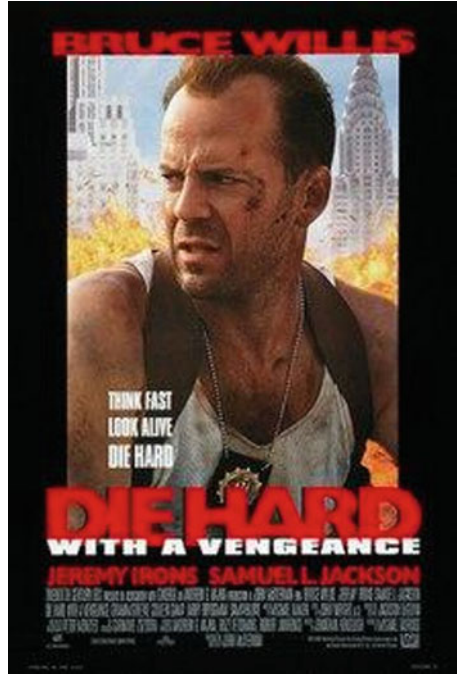
It may seem strange! We have chosen the film *Die Hard with a Vengeance* (McTierna, 1995), because although it has been chosen and treated by mathematics education professionals (teachers and researchers), the approach we have given it allows us to formalize several interesting mathematical concepts (Figs. 3.8 and 3.9).

Different authors have approached the problem with different perspectives and interesting contributions. It would not be fair to understand the cinema as a company that only contemplates the production of commercial films, fiction or not. There are many films with a numerical title and different thematic content: *The Dirty Dozen* (1957), war; *Twelve Angry Men* (1957), court drama; *21 grams* (2003), family drama; *The number 23* (2007), suspense and murders; *Friday the 13th* (2009), horror; *300* (2007), historical; *Murder in 8 mm* (1999), intrigue...

In the chosen film, *Die Hard with a Vengeance* (1995) certain situations are detected that well attract our attention when it is viewed with mathematical eyes. This is demonstrated by the interest it has provoked in many professionals in the teaching of Mathematics.

It is about starting from a hero who has to save the city of New York and not only must he make crazy car races, fight and do stunts; he will also have to solve a well-known math puzzle. How difficult it is to be a hero, in these times, when you have to defuse a bomb, especially when saving your life may depend on the quick solution of a classic problem that appears in high school mathematics textbooks as a paradigm of transfer of any liquid!

**Fig. 3.8** Die Hard with a Vengeance



**Fig. 3.9** Scene 1. Die Hard- Bruce Willis-Samuel L. Jackson

**Scene:** We take the scene that takes place between minutes 55:30 and 59:50 of the film.

**Level:** Any high school course

**Topic:** Algebra.

**In the classroom:** This well-known problem appears in almost all high school textbook collections, with no relevance to one course or another. That is why, after solving it in the classroom, it is very curious and fun for the student to see the difficulties that he/she goes through in front of the problem of a cinematographic hero.

**Argument and context:** The film shows that mathematics can solve perverse situations: neutralize a bomb by solving an enigma.

A man who calls himself Simon (played by Jeremy Irons) starts a wave of terror through the streets of New York. As a cunning terrorist, Simon sets off a bomb in a busy New York shopping mall, then reveals more explosives threatening the city. John McClane (played by Bruce Willis) will have to overcome the successive tests that the perverse terrorist submits to him, with the company of Zeus (played by Samuel L. Jackson), an occasional hero.

*One of those tests consists of defusing a bomb that is in a fountain in a park and it will explode in 5 minutes unless McClane manages to deposit exactly 4 liters of water on it. For this he has two non-graduated carafes: one of 3 liters and the other of 5. How will they do it?*

The solution to this problem, chosen and treated by mathematics education professionals (teachers and researchers), allows the formalization of several interesting mathematical concepts (Romero & Benítez, 2008) the diophantine equations and the Euclidean algorithm.

### Solution

If we reflect a little, the solution is simple.

Let's see the steps.

**Step 1:** Fill 3 liter drum A and pour the contents into 5 liter drum B. Let us represent the situation in the following figure (Fig. 3.10).

**Step 2:** Drum A is filled again, and the content is poured into drum B until it is full. What is the situation now? There is 1 liter in drum A, and drum B is full (Fig. 3.11).

**Step 3:** Drum A is emptied and the content of 1 liter that is in drum A is poured into drum B (Fig. 3.12).

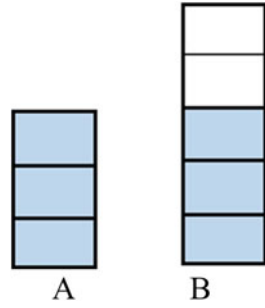
**Step 4:** The 3 liter drum is refilled and poured into the 5 liter drum. We then obtain the 4 liters requested (Fig. 3.13).

### Notes:

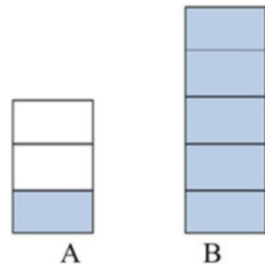
- a) The great French mathematician Siméon Denis Poisson (1781–1840) revealed the interest of mathematics in solving this type of problem.

The students are asked to go deeper into the problem, with drum A, 3 liters, they can obtain 3, 6, 9,...,3a liters with a belonging to the natural numbers, N, and with drum B, of 5 liters, 5,10,15,...,5b liters are obtained with b belonging to the natural numbers.

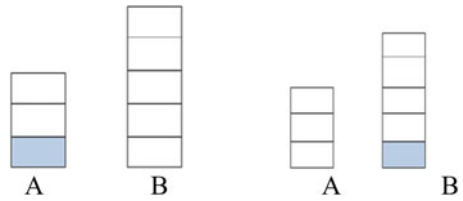
**Fig. 3.10** Step 1, transfer of water between drums A and B



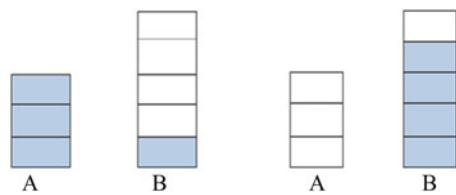
**Fig. 3.11** Step 2, transfer of water between drums A and B



**Fig. 3.12** Step 3, transfer of water between drums A and B



**Fig. 3.13** Step 1, transfer of water between drums A and B



b) If you want to get 4 liters, you need to use the two drums and how  $4 \neq 3a + 5b; \forall a, b \in \mathbb{N} \cup \{0\}$ , it is necessary to pour the water from one drum to another; this demonstrates the need to use negative integers in solving the problem.



That is why the solution adopted in the film by the actors B. Willis and S.L. Jackson, can be written as:

$$4 = 3.3 + (-1).5,$$

that is

$$a = 3, b = -1.$$

c) At this point we invite the students to try to solve the question: ***Can any number of liters of water be obtained?***

The fact of obtaining a liter by manipulating the two drums in the way

$$1 = 2.3 + (-1).5$$

It is an interesting result, because it allows, repeating the process, to obtain any number of liters.

With the experience gained with this example, we can say that watching movies is a good excuse to motivate our students, guiding them and educating them on how to get an academic performance from a movie that in principle is nothing more than an action film. However, if you “see” with mathematical eyes, things change. With a starting point in this movie you can get a walk through the Euclid Algorithm, Diophantine Equations and Continuous Fractions.

It is an exercise that can be used as an attractive resource in the classroom for which number theory is used when modeling it, starting the process with the identity of Bezout (French mathematician Étienne Bézout born in Nemours on March 31, 1730 and died in Avon on September 27, 1783) as a study of the solution of the diophantine equation  $ax + by = c$  using Euclid’s algorithm (Bach & Shallit, 1996) which gives us the opportunity to introduce the student in your interest in the history:

- Geometric original algorithm
- Generalized classical algorithm
- Practical applications with simplifying fractions
- Continuous fractions
- Lamé’s theorem using Euclid’s algorithm to calculate the number of divisions necessary to find the greatest common divisor of two integers
- To conclude with the study of diophantine equations

In the historical consultation on diophantine equations (Andreescu et al., Andreescu et al., 2010), some solution methods are detected that were used by some civilizations and cultures to solve the so-called diophantine equations, but these methods were applied to equations of the form  $ax + by = c$  that were subject to systems of linear equations, were looking for unique solutions and it was only until the work of Diophantus, pioneer of solution methods for these equations, without being subject to a system of linear equations, where they began to be search for infinite solutions, thus showing that the problem of uniqueness and infinity has been worked on for many years.

From this example, students are provided with bibliographical material to delve into a historical study of the birth of the Diophantine equations (Britannica, 2014).

Diophantus of Alexandria (Fernández & Tamaro, 2004; Sesiano, 2021), is a Greek mathematician whose writings contributed significantly to the refinement of algebraic notation and the development of algebraic knowledge of his time. By means of calculation artifices he was able to give particular solutions to numerous problems, and established the bases for a later development of important mathematical questions. Several volumes of *Arithmetic* (book of collective inspiration, but written by a single author) and fragments of *Porismas* and *Polygonal Numbers* are preserved from his work.

We know nothing about the homeland of this Greek mathematician and very little about his life. He belonged to the Alexandrian school, was born around 250 and died at the age of eighty-four. A dedication of his to a certain Dionysius, who wanted to identify himself with the contemporary saint of the same name, Bishop of Paris, has led him to believe that he was a Christian.

For his originality and his contributions, Diophantus was called by historians the father of modern algebraists. In an age of decadence and pure exegesis, such as the century in which he lived, his work is a notable exception. He is generally credited with introducing algebraic calculus to mathematics. Apparently, he initiated the systematic use of symbols to indicate powers, equalities or negative numbers.

Of the work of Diophantus the first six books and a fragment of the seventh of a treatise entitled *Arithmetic*, originally made up of thirteen, are preserved. The preserved books contain a treatise on determined and indeterminate equations and systems of equations, in which the solution is systematically sought in rational numbers. A text of his on polygonal numbers has also come down to us. The ancients also considered theirs a book of *porism* (mathematical proposition or corollary. In particular, the term “porism” has been used to refer to a direct result of a proof, much as a corollary is used to refer to a direct result of a theorem) and a treatise on fractions, *Moriastica*.

Obviously, we are not going to undertake an exhaustive study of the history of diophantine equations (Schmidt, 1991), understood as equations with integer coefficients, whose solutions are sought in the set of integers. The bibliography consulted indicates that there has been a wide journey, over time with approaches and solutions of equations from ancient cultures to the sixteenth century, there are contributions from some cultures to the approach and solution of equations, highlighting in some of them (the oldest) a representation with a purely rhetorical character since they did not have the current symbolic notation to which they are accustomed; Likewise, their solutions could only be positive or zero, since they did not have the notion of negative numbers that were later adapted to the solution of equations, through the Greek culture in the seventh century and Arab culture in the ninth century (taking them into account as elements or rules of operation).

Some ancient cultures such as the Babylonian, Greek and Indian cultures have found in mathematics a fundamental basis for their development and in equations a tool for solving problems in their environment. At the same time they do a job with

the equations for the solution of problems clearly mathematicians who generated the basis of his great knowledge in this science.

Historically, Arithmetic was of utmost importance, because it exerted a remarkable influence both on the development of algebra among the Arabs (who translated it into their language in the tenth century) and on modern number theory. Translated into Latin in 1571, it was published in the Greek text in the seventeenth century by Bachet de Méziriac (Collet & Itard, 1947) who found in it the way to develop the so-called determined analysis.

With this work methodology, interactive activities can be promoted based on some scenes from a movie, trying to promote a taste for Mathematics through the cinema.

Definitely, with this attitude we want to show, based on the accumulated experience in the investigations carried out, that the problematized and modeled teaching of mathematics allows us to make reality: “. . . *in principle, there is a modeling process behind everything mathematical model. This means that someone implicitly or explicitly has gone through a process of establishing a relationship between some mathematical idea and a real situation. In other words, in order to create and use a mathematical model it is necessary, in principle, to go all the way through a modeling process. . .*”. (Morten Blomhøj, 2004).

We have verified at the different levels of education in various primary, secondary and university centers that carrying out a “small or large mathematization” accompanied, as a tool, by the history of mathematics represents the core part of the Teaching / Learning model of mathematics . . .

Modeling in/with mathematics represents reaching out to our daily actions that we carry out in the environment that surrounds us. With this, we also mathematize culture through school and institutional actions, in short, social ones.

## Conclusion

The topic of models and modeling has come to be important for science and mathematics education in recent years. The topic of “Modeling” (Arseven, 2015) is especially important and influenced by major empirical studies of educational achievement TIMSS (Trends in International Mathematics and Science Stud), developed by the International Association for the Evaluation of Educational Achievement (IEA) TIMSS), the Program for International Student Assessment (PISA), and the Progress in International Reading Literacy Study (PIRLS) that allows participating nations to compare the educational achievement of students across borders.

Mathematical modeling can be defined as using mathematics to explain and define the events in real life, to test ideas and to make estimations about real life events. Rapid development of information and technology today changed society's expectations from people and education world. Today's world expects mathematics teachers to raise individuals who are able to create effective solutions in cases of real

problems and use mathematics effectively in their daily lives. Thus, they will enjoy mathematics instead of being scared of it and comprehend and appreciate the importance and power of mathematics.

Some reflections on the theoretical basis of mathematical modelling, model and the concepts of modeling activity are exposed in this work. Emphasis is placed on the fact that it is relatively recent that researchers in Mathematics Education have focused their attention on the design of activities based on the mathematical modeling of real situations with the conviction of obtaining a greater guarantee in the gain, by our students, of mathematical learning and therefore in the teaching by the teachers.

Remarkable is that in this chapter we have presented some of the lines of development aimed at recognizing the history of mathematics as a valid instrument and recognizing the social and political values that shape the of mathematics curricula.

The work presented wants to show, based on the experience accumulated in the research carried out, that problematized and modeled teaching of mathematics allows us to make it a reality (Morten Blomhøj 2004).

We have verified at the different levels of education in various primary, secondary and university centers that: "... carrying out a "small or large mathematization" represents the nuclear part in the Teaching/Learning model of mathematics...".

Modeling in/with mathematics represents reaching out to our daily acts that we carry out in the environment that surrounds us. With this, we also mathematize culture through school, institutional, . . . ultimately social actions.

Finally, we are convinced that it is necessary to continue researching the use of the history of mathematics in a problematized and modeled teaching of mathematics through various examples of application in the context of the ERACIS Project with the experience carried out by the author. of this work, in a high school class for gifted students, in times of uncertainty, such as COVID19 (in this period, we all have suffered adversities as part of our lives, we will bump into them from time to time. When that happens, it will The most important thing is not the experience we live, but how we live it and what we do with it) in a center whose teachings are based on the Regional Strategy of the region of Andalusia (Spain) for Cohesion and Social Inclusion. We can affirm that the exploration of the history of development leads to establishing a relationship between cognitive processes and the learning of mathematics, by solving various tasks such as those mentioned (for example, calculating the square root of a large number and/or solving a diophantine equation).

**Acknowledgments** (a) To the University of Huelva (Spain) and High school IES Marisma de Huelva for educational innovation project, *Management of Mathematical Talent in times of uncertainty in secondary school students in an ERACIS center-UHU-2021-2021*. (b) Proyecto TOCAR LAS MATES-YO TUVE CIENCIA (2021). Activity framed in the dissemination of research carried out at the University of Huelva for young people. Consejería de Transformación Económica, Industria, Conocimiento y Universidades. OTRI. University of Huelva. European Union. Regional Development Fund.

## References

- Anacona, M. (2003). La historia de las matemáticas en la educación matemática. *Revista EMA*, 8(1), 30–46.
- Andresescu, T., et al. (2010). In Birkhäuser (Ed.), *An introduction to Diophantine equations. A problem-based approach* (pp. 67–70). Springer.
- Anglin, W. S. (1994). *Mathematics: A concise history and philosophy*. ISBN 0-387-94280-7 e ISBN 978-0-387-94280-3.
- Aravena, M. (2001). Evaluación de proyectos para un curso de álgebra universitaria. Un estudio basado en la modelización polinómica. *Tesis Doctoral. Departament de Didáctica de la Matemática i de les Ciències Experimentals*. Barcelona (España).
- Aravena, M., & Caamaño, E. C. (2007). Modelización matemática con estudiantes de secundaria de la comuna de Talca, Chile. *Estudios Pedagógicos XXXIII*, 2, 7–25.
- Arboleda, L. C. (1983). Historia y enseñanza de las matemáticas (nº 4, *Serie Epistemología, Historia y Didáctica de la Matemática*). Universidad Nacional de Colombia.
- Arseven, A. (2015). Mathematical modelling approach in mathematics education. *Universal Journal of Educational Research*, 3(12), 973–975.
- Atiyah, M. (2000). In *mathematics: Frontiers and perspectives, by the International Mathematical Union*. Publications of the American Mathematical Society.
- Bach, E., & Shallit, J. (1996). Algorithmic number theory. *Volume I: Efficient algorithms*. Chapter 4: The greatest common Divisor. MIT Press.
- Barbin, E. (1996). The role of problems in the history and teaching of mathematics. In R. Calinger (Ed.), *Vita Matemática. Historical research and integration with teaching*. MAA Notes. No. 40 (pp. 17–25).
- Barbin, E., Bkouche, R., Bühler, M., Friedelmeyer, J. P., Guillemot, M., Hallez, M., Jozeau, M., Kahn, C., & Plane, H. (1996). *Pour une perspective historique dans l'enseignement des mathématiques*. Bulletin Inter-IREM épistémologie.
- Blomhøj, M. (2000). *Developing modelling competence: The different roles of modelling and problem solving*. Roskilde University.
- Blomhøj, M. (2004). Mathematical modelling – a theory for practice. In B. Clarke, D. Clarke, G. Emanuelsson, B. Johnansson, D. Lambdin, F. Lester, A. Walby, & K. Walby (Eds.), *International perspectives on Learning and teaching mathematics* (pp. 145–159). National Center for Mathematics Education.
- Britannica. (2014). Diophantine equation. *The Editors of Encyclopaedia*. Encyclopedia Britannica, 26. <https://www.britannica.com/science/Diophantine-equation>
- Cajori, F. (2007). A history of mathematical notations I (1928–29). Reprinted by Cosimo.
- Cilleruelo, J. (2000). La conjetura de Goldbach. *Gaceta de la Real Sociedad Matemática Española*, 3(3), 557–565. <https://eudml.org/doc/43270>
- Collet, C. G., & Itard, J. (1947). Un mathematician humaniste : Claude-Gaspar Bachet de Meziriac, 1581–1638. *Revue d'histoire des sciences*, 1, 26–50. <https://mathshistory.st-andrews.ac.uk/Biographies/Bachet/>
- Guzman, M. de (1994). Impactos de la Matemática sobre la Cultura, en: La Ciencia ante el siglo XXI. *Ciclo de conferencias de la Real Academia de Ciencias Exactas, Físicas y Naturales (Fundación Ramón Areces, Madrid, 1995)*, 21–54. (Texto de una conferencia en la Fundación Ramón Areces).
- De Lange, J., Keite, C., Huntley, I., & Niss, M. (1993). *Innovations in maths education by modelling and applications*. Ellis Horwood.
- Euler's Correspondence with Christian Goldbach. <https://eulerarchive.maa.org/correspondence/correspondents/Goldbach.html>
- Fernández, T., & Tamaro, E. (2004). Biografía de Diofanto de Alejandría. En Biografías y Vidas. *La enciclopedia biográfica en línea*. Barcelona, España. <https://www.biografiasyvidas.com/biografia/d/diofanto.htm>

- Freire, P. (1997). *Pedagogía de la Autonomía: Saberes necesarios para la práctica educativa México, Siglo XXI*, 22–41. <https://redclade.org/wp-content/uploads/Pedagog%C3%ADa-de-la-Autonom%C3%ADa.pdf>
- Freire, P. (2000). *Pedagogia da autonomia: saberes necessários à prática educativa. 7 ed. São Paulo: Paz e Terra* (original de 1996).
- Freudenthal, H. (1983). Didactical phenomenology of mathematical structures. In *Mathematics Education Library*. D. Reidel Publishing Company.
- Fuss, P. H. (1843). Correspondance mathématique et physique de quelques célèbres géomètres du XVIIIème siècle, précédé d'une notice sur les travaux de Léonard Euler, tant imprimés qu'inédits et publiée sous les auspices de l'Académie impériale des sciences de Saint-Petersbourg. Ed. P. H. (Paul Heinrich), 1797–185. St.-Petersbourg [De l'impr. de l'Académie impériale des sciences]. Digitizing sponsor Google (2008). <https://archive.org/details/correspondancem01goldgoog/page/n75/mode/2up>
- García, J. A. (2008). Génesis histórica y enseñanza de las matemáticas. *Rev. UNIÓN. Número, 15*, 61–87.
- Gheverghese, J. G. (2000). *The crest of the peacock: The non-European roots of mathematics*. Londres. ISBN 0-691-00659-8 e ISBN 978-0-691-00659-8.
- Goldbach, C. (1690–1764). <https://www.britannica.com/science/Goldbach-conjecture>
- Gravemeijer, K. P. E. (1994). Developing realistic Mathematics Education. In *Center for Science and Mathematics Education, Freudenthal Institute, Research Group On Mathematic Education*. Utrecht University.
- Hiriart-Urruty, J. B. (2011). El papel de las conjeturas en el avance de las matemáticas: vueltas y revueltas con ayuda de ejemplos. *Conferencias del Departamento de Estadística e Investigación Operativa. Universidad de Alicante (España)*. Institut de mathématiques. Université Paul Sabatier. Toulouse. <https://dmat.ua.es/es/documentos/actividades/conferencias/conferencia20110511-conjeturas.pdf>
- Kahane, J. P. (2002). L'enseignement des sciences mathématiques Commission de réflexion sur l'enseignement des mathématiques. Ed. *Odile Jacob Rapport au Ministre de l'Éducation Nationale*.
- Keitel, C., Kotzmann, E., & Skovsmose, O. (1993). Beyond the tunnel vision: Analysing the relationship between mathematics education, society and technology. In C. Keitel & K. Ruthven (Eds.), *Learning from computers: Mathematics education and technology* (pp. 242–279). Springer.
- McTierna, J. (1995). *Die hard with a vengeance* (1995). American action thriller film. [https://en.wikipedia.org/wiki/Die\\_Hard\\_with\\_a\\_Vengeance](https://en.wikipedia.org/wiki/Die_Hard_with_a_Vengeance)
- Menon, U. (2013). Mathematisation-vertical and horizontal. epISTEME 5 international conference to review research on science, technology and mathematics education, conference proceedings. Mumbai, India. <http://episteme5.hbce.tifr.res.in/index.php/episteme5/5/paper/view/168/52>
- Meza, L. G. (2009). Elementos de pensamiento crítico en Paulo Freire: Implicaciones para la educación superior. *Revista Digital Matemática, Educación e Internet*, 10(1), 1–10. Costa Rica.
- Poisson, S. D. (1781–1840). <https://mathshistory.st-andrews.ac.uk/Biographies/Poisson/>
- Polya, G., & Szego, G. (1972). *Problems and theorems in Analysis*. Springer-Verlag.
- Richstein, J. (2001). Verifying the Goldbach conjecture up to  $4 \times 10^{14}$ . *Mathematics of Computation*, 70(236), 1745–1749. <https://www.ams.org/journals/mcom/2001-70-236/S0025-5718-00-01290-4/>
- Rodríguez, M. E., & Mosqueda, K. (2015). Aportes de la pedagogía de Paulo Freire en la enseñanza de la matemática: hacia una pedagogía liberadora de la matemática. *Revista Educación y Desarrollo Social*, 9(1), 82–95. Bogotá (Colombia).
- Romero, S. (2011). La resolución de problemas como herramienta para la modelización matemática. *Modelling in Science Education and Learning. Volume 4, No. 4. Instituto Universitario de Matemática Pura y Aplicada*. Valencia, 41–47.

- Romero, S., & Benítez, R. (2008). De la Jungla de Cristal III a las ecuaciones diofánticas pasando por el algoritmo de Euclides. *Rev. Epsilon: Revista de la Sociedad Andaluza de Educación Matemática "Thales"*, 7–26. (Page on the synopsis of the film The Crystal Jungle III). <http://www.filmaffinity.com/es/film971189.html>. <http://www.hoycinema.com/Jungla-cristal-III-venganza-1995.html>
- Romero, S., & Benítez, R. (2021a, 2022). Gestión del talento matemático en tiempos de incertidumbre-COVID19- en alumnos de Enseñanza Secundaria Obligatoria en un centro ERASCIS (Estrategia Regional Andaluza para la Cohesión e Inclusión Social). En: *Modalidad C: proyectos que impulsan la colaboración con centros docentes públicos no universitarios*. [https://www.uhu.es/innovacion\\_docente/ConvPID\\_2021\\_2022/RESOLUCION\\_DEFINITIVA\\_21\\_22.pdf](https://www.uhu.es/innovacion_docente/ConvPID_2021_2022/RESOLUCION_DEFINITIVA_21_22.pdf)
- Romero, S., & Benítez, R. (2021b, 2022). Proyecto TOCAR LAS MATE-S-YO TUVE CIENCIA (2021). Activity framed in the dissemination of research carried out at the University of Huelva for young people. Consejería de Transformación Económica, Industria, *Conocimiento y Universidades*. OTRI. University of Huelva. European Union. Regional Development Fund. <https://www.youtube.com/watch?v=ZHYDNzxpimg>
- Romero, S., & Romero, J. (2015). ¿Por una enseñanza problematizada y modelizada de las matemáticas? Estudio de casos. *Uno: Revista de didáctica de las matemáticas*, 69, 33–43.
- Romero, S., Rodríguez, I.M., Salas, I.M., Benítez, R., & Romero, J. (2014). La Resolución de Problemas (RdP's) como herramienta para la modelización matemática: ejemplos de la vida real. *IV Jornadas sobre Modelización MATEMÁTICA. Matemáticas a lo largo de la vida*. Universidad Internacional de Andalucía. Palos de la Frontera (Huelva).
- Sáenz, C. (2001). Sobre conjeturas y demostraciones en la enseñanza de las matemáticas. In *V Simposio de la Sociedad Española de Investigación en Educación Matemática* (pp. 47–51). Almería.
- Schmidt, M. (1991). Aproximaciones diofánticas y ecuaciones diofánticas. In *Apuntes de clase en Matemáticas* (Vol. 1467). Springer.
- Sesiano, J. (2021). Diophantus. *Encyclopedia Britannica*, 25. <https://www.britannica.com/biography/Diophantus>
- Suzuki, J. (2009). *Mathematics in historical context*. MAA. [https://books.google.es/books/about/Mathematics\\_in\\_Historical\\_Context.html?id=lew5IC5piCwC&redir\\_esc=y](https://books.google.es/books/about/Mathematics_in_Historical_Context.html?id=lew5IC5piCwC&redir_esc=y)
- Tartaglia, N (1500–1557). <https://mathshistory.st-andrews.ac.uk/Biographies/Tartaglia/>
- Treffers, A. (1987). Three dimensions: A model of goal and theory description in mathematics instruction. In *The Wiskobas project*. Reidel.
- Wiles, A. (1995). Modular elliptic curves and Fermat's last theorem. *Annals of Mathematics*, 443, 55.

# Chapter 4

## The Introduction of the Algebraic Thought in Spain: The Resolution of the Second Degree Equation



María José Madrid, Carmen León-Mantero, and Alexander Maz-Machado

**Abstract** Algebraic contents first appeared in Spain in printed form in 1552, when the book *Libro primero, de Arithmetica Algebraica* written by the German Marco Aurel was published. Since then, different Spanish mathematics books have included algebra and therefore, their study allows knowing how the algebraic thought was introduced in Spain. Here we analyze Spanish mathematics books written during the 16th, 17th and 18th centuries, in order to study an important topic of research in the history of mathematics and mathematics education, how equations were solved. In particular, we focus our study on the different resolutions for quadratic equations included in these books. We made an exploratory, *ex post facto*, descriptive study using content analysis of old Spanish mathematics texts, which included algebraic thinking. The analyzed books show the evolution in the presentation of algebraic contents and the different resolutions included by the authors for this topic. Furthermore, from an ethnomathematical point of view, this study shows the relationship between the Spanish context of each time and the introduction of algebraic thought and it can be a useful tool for nowadays teaching and learning process of this topic.

**Keyword** History of mathematics and mathematics education · Algebra · Spanish mathematics books · Quadratic equations

---

M. J. Madrid  
Universidad Pontificia de Salamanca, Salamanca, Spain  
e-mail: [mjmadridma@upsa.es](mailto:mjmadridma@upsa.es)

C. León-Mantero · A. Maz-Machado (✉)  
Departamento de Matemáticas, Universidad de Córdoba, Córdoba, Spain  
e-mail: [cmleon@uco.es](mailto:cmleon@uco.es); [malmamaa@uco.es](mailto:malmamaa@uco.es)



## Introduction

Among the topics of research on history of mathematics and mathematics education, there are included how different methods of mathematical thought, such as induction, algebraic thought, analytic geometry, infinitesimal calculus, topology, probability . . . have arisen in different historical circumstances.

For example, García (2015) shows Jorge Juan's role in the introduction of infinitesimal calculus in Spain; Ausejo and Medrano (2012) study the introduction of infinitesimal calculus in Spain by analyzing Gabriel Ciscar's book on infinitesimal calculus. León-Mantero et al. (2022) analyse the introduction of the cosine theorem for solving triangles in Spanish trigonometry textbooks. Millán (1991) deals with the introduction of French *géométrie moderne* in the Spanish universities and the role of projective geometry in 20th mathematics studies in the Spanish universities. Ageron and Hedfi (2020) present Ibrāhīm al-Balīshṭār's Arabic treatise on arithmetic, which was created by intertwining two Spanish treatises and drawn material from Arabic authors, these authors consider it an original attempt to create a Euro-Islamic hybrid knowledge.

Focusing on algebraic thinking, Christianidis and Megremi (2019) examine the influence of Diophantus' *Arithmetica* in mathematical texts written until early medieval times, focusing on some scholia used to solve problems. Oaks (2019) analyzes a commentary written by the Persian mathematician al-Fārisī on a practical arithmetic book. Al-Fārisī aimed to provide rigour by formally proving different arithmetical results following the methods of Euclid's number theory books; and he even presented a proof using polynomial algebra to overcome the differences between Arabic and Euclidean numbers. Cifoletti (2021) discusses the solutions for second degree equations introducing the sixteenth-century algebraic quantities as a new version of Euclid's plane and solid numbers, but geometrically constructed from Pacioli to Nunes.

These studies are just a small sample of the interest that researchers on the history of mathematics and mathematics education have on the evolution of mathematical thought over time, and in particular on the development of algebraic thinking; however, there are still many issues to be considered (Parshall, 2017; Puig, 2022).

Therefore, in this paper, we focus our attention on one component of the history of algebraic ideas that Puig (2003, 2022) highlights: history of equation solving. In particular, we focus our study on the different resolutions for second degree (quadratic) equations with only one unknown value.

A quadratic equation is any equation that can be rearranged in standard form as:

$$ax^2 + bx + c = 0$$

where  $x$  is the unknown term,  $a$ ,  $b$ , and  $c$  are constants and  $a \neq 0$ .

Nowadays, Spanish mathematics textbooks for secondary education include for the resolution of second degree equations mainly three possibilities:

- If the second degree equation is incomplete because  $c = 0$ , the solutions (roots) of the quadratic equation  $ax^2 + bx = 0$  are:

$$x = 0 \text{ and } x = \frac{-b}{a}$$

If the second degree equation is incomplete because  $b = 0$ , the solutions (roots) of the quadratic equation  $ax^2 + c = 0$  are:

$$x = \pm \sqrt{\frac{-c}{a}}$$

If  $-c/a > 0$  these roots are real, if  $-c/a < 0$  these roots are imaginary.

- If the second degree equation is complete, the solutions (roots) are given by this formula:

$$x = \frac{-b \pm \sqrt{b^2 - 4ac}}{2a}$$

These roots depend on the discriminant of the quadratic equation:  $b^2 - 4ac$ . If  $b^2 - 4ac > 0$  the quadratic equation has 2 real roots. If  $b^2 - 4ac < 0$ , the two roots of the quadratic equation are complex. If  $b^2 - 4ac = 0$  there is only one double root.

Here we consider if this approach has always been the most common one, or if the resolution of second degree equations has been posed in different ways through the history of mathematics and mathematics education.

Resolution of quadratic equations has a long history, which dates back to Babylonian culture (Boyer, 1968). Magnaghi-Delfino and Norando (2019) analyze how in some Babylonian tablets, there are methods of resolution of some second degree equations using geometric constructions.

Neugebauer (1957) points out that Babylonians already posed problems involving these equations, and he puts as an example the following problem: find the side of a square knowing that its area minus its side is equal to 14,30. Then he indicates that the solution given was equivalent to the one obtained applying the following formula, which is one of the roots of the equation  $x^2 - px = q$ .

$$x = \sqrt{\left(\frac{p}{2}\right)^2 + q} + \frac{p}{2}$$

Smith (1958) points out that Berlin Papyrus included the solution of a quadratic equation. In particular, the problem posed can be solved considering the equations  $x^2 + y^2 = 100$  and  $y = \frac{3}{4}x$ . And it is solved in Berlin Papyrus by a false position method. Some geometrical propositions presented in Euclid's *Elements* are the geometrical equivalent of quadratic equations. For example, Boyer (1968, p. 145)

states that propositions 84 and 85 are geometrical substitutes for the Babylonian algebraic methods to solve the systems  $xy = a^2$  and  $x \pm y = b$ . So they are also equivalent to quadratic equations.

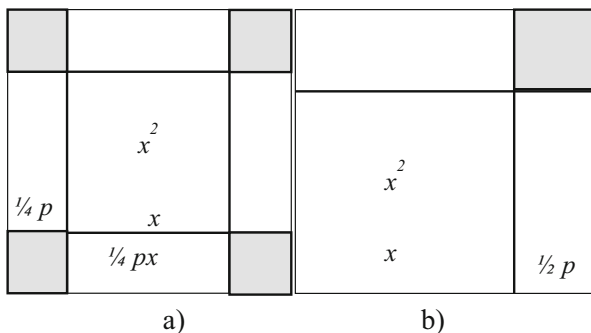
Diophantus knew how to solve equations like  $ax^2 + c = bx$ . To solve the same problems with quadratic equations that Babylonians solved, he made it in a strictly algebraic form (Katz, 2009, p. 179). He provided an introduction to symbolism in the solution of equations, but he considered only positive answers (Smith, 1958). In problem IV-39 of *Arithmetica*, he pointed out as a solution to solve the equation  $c + bx = ax^2$ , the expression:

$$x = \frac{\frac{b}{2} + \sqrt{ac + (\frac{b}{2})^2}}{a}$$

Later in India, Brahmagupta wrote *Brahma-sphuta-siddhanta* (The revised system of Bramha), a text dedicated to astronomy, whose chapters 12 and 18 are about mathematics. In chapter 18, he discussed how to solve Diophantine equation  $x^2 = 1 + py^2$ , which was solved by Bhaskara (n. 1114) for positive integers and small p-values (Boyer, 1968; Gray, 2010 & Koley, 2022).

During the rise of Arabic algebra, Al-Khwārizmī relied on Greek methods to solve quadratic equations (Vallhoneste et al., 2015). He established five rules for solving quadratic equations, that he divided into five forms:  $ax^2 = bx$ ,  $ax^2 = c$ ,  $ax^2 + bx = c$ ,  $ax^2 + c = bx$  and  $ax^2 = bx + c$ , where a, b, c are positive numbers and in all cases  $a = 1$  (Rouse Ball, 1960). In order to solve them, he used two methods, in the first one, he relied on a geometric construction and thus he justified his solution for the equation  $x^2 + px = q$ . For example, for the equation  $x^2 + 10x = 39$ , he made a square of side x, he enlarged it with rectangles of sides  $\frac{1}{4}p$  (Fig. 4.1a), and he obtained as a solution  $x = 3$  (Paradis & Malet, 1989; Smith, 1958). The second method is also similar. In Fig. 4.1b, the unshaded part is  $x^2 + px$ , and he added the square of  $\frac{1}{2}p$ . By doing so, he obtained the equation  $x^2 + px + \frac{1}{4}p^2 = \frac{1}{4}p^2 + q$ , therefore,  $x = \sqrt{\frac{1}{4}p^2 + q} - \frac{1}{2}p$  considering only the positive root (Rouse Ball, 1960; Smith, 1958).

**Fig. 4.1** Examples of geometric methods used by Al-Khwārizmī in order to solve quadratic equations



Leonardo of Pisa in his book *Liber Quadratorum* (1225) discussed the solutions with rational numbers of some equations that included squares. Jordanus de Nemore made advances on Leonardo's work and in his *Arithmetica*, he posed the problem of finding three square numbers whose continuous differences were equal. His solution in current notation is:

$$y = \frac{a^2}{2} + ab - \frac{b^2}{2}; \quad x = \frac{a^2 + b^2}{2}, \quad z = \frac{b^2}{2} + ab - \frac{a^2}{2}$$

Where  $a$  and  $b$  are of equal parity (Katz, 2009).

Luca Pacioli established three compound rules for algebraic equations (Fauvel & Gray, 1991). François Viète differed from his predecessors, because he replaced geometric methods by analytical methods in the solution of quadratic equations, but he still accepted only positive solutions (Boyer, 1968; Smith, 1958; Puig & Rojano, 2004). For the equation  $A \text{ quad} + B^2$  in  $A$  equals  $Z$  plane, which is equivalent to  $A^2 + 2BA = Z$  in current notation, he gave as solution  $A = \sqrt{Z + B^2} - B$ , and what's more, this was the first time that the term quadratic formula was used (Katz, 2009).

Smith (1958) states that if the modern methods developed to obtain the formula for the solution of the quadratic equation are considered, the one using determinants is of theoretical interest. This method was developed by Euler and Bézout and improved by James Joseph Sylvester and Otto Hesse.

Therefore, many mathematicians dedicated their time and efforts to solve quadratic equations, which have had a relevant role in the history of solving equations. Here we aim to analyze different Spanish mathematics books written during the 16th, 17th and 18th centuries in order to study this important topic of research in the history of mathematics and mathematics education, how quadratic equations were solved.

This study follows the line of research posed in Madrid, León-Mantero, et al. (2019a), who focus on the definition of equation given by several Spanish authors from the eighteenth century. Also, Madrid et al. (2020) analyse the 18th the century Spanish mathematics books that included algebra.

The aim of this study is to know which mathematics books published between the sixteenth century and the eighteenth century included second degree equations and what approach was posed for them. From an ethnomathematical perspective (Rosa & Shirley, 2016), this allows us to consider two main issues:

On the one hand, we explain the Spanish evolution of methods for solving second-degree equations since their first printed appearance, showing that mathematics is a human activity, and that both mathematical concepts and structures have developed over time. On the other hand, we present past obstacles and difficulties that nowadays teachers and students may encounter by solving second degree equations, considering that this can help to establish connections between past and present mathematics issues.

## Methodology

We present an exploratory, descriptive and *ex post facto* research. The nature of this research is historical mathematic and it is based on the analysis of old mathematics textbooks.

In order to carry out this study, we have used the content analysis technique for books (Neuendorf, 2002), following the guidelines set out in Maz (2009) and that we have already used in previous studies on the history of mathematics and mathematics education (Madrid et al., 2017; Madrid, Maz-Machado, et al., 2019b).

Each paragraph included in the books that was focused on solving second degree equations was defined as a unit of analysis. These paragraphs were read, analyzed and subsequently categorized through a review by experts on the History of Mathematics Education.

The large number of books that include algebra contents would make a detailed analysis impossible, also the following selection criteria adapted from (Madrid et al., 2020), were considered:

- Publication date: the first publication of each book took place during 16th -18th centuries, so we focus our study just on the introduction of algebra in Spain.
- Algebra: all the books analyzed include at least algebraic contents.
- Language: only books printed in Spanish were considered due to its greater scope in Spain. Therefore, books written in Latin or in other languages in Spain during these centuries were not considered.
- Printing: only printed books were considered, so manuscripts are not part of our study. Among the reasons for this decision, we consider that it is not always possible to know when a manuscript was written, who was its author, for what purpose it was written, etc.
- Edition: whenever possible, the first edition of each book was considered. Although comparative analysis among different editions could be interesting, due to the number of books that include algebra contents, we have considered the first edition of each book sufficient for our sample, unless another edition was of special interest.
- Typology: Printed descriptions of exams or public contests at the time were not considered, because we have focused our study on how authors explained and solved quadratic equations, not on their presence in different institutions.
- Availability of the text: the date of publication of these books might make it difficult to access them, therefore, the chosen books are available when it is necessary. This means that our sample is intentional and for convenience.

Books were mainly searched and located through Biblioteca Digital Hispánica of the Biblioteca Nacional de España and Google Books digital repository. We selected:

- Sixteenth century: 6 books
- Seventeenth century: 3 books
- Eighteenth century: 18 books

Taking into account studies like Beeley et al. (2020), León-Mantero et al. (2020), Madrid et al. (2019a, b), Madrid et al. (2020), Maz and Rico (2015), Meavilla and Oller (2014), Paradis and Malet (1989), Puig and Fernández (2013) or Rey (1934), we consider that these books are a sufficiently representative sample of Spanish printed books with algebraic content in these three centuries.

## Results

### *Sixteenth Century Books*

In the Spanish city Valencia in 1552 the book *Libro primero, de Arithmetica algebraica* (Aurel, 1552) written by the German Marco Aurel was published; it is considered the first Spanish printed book that includes algebraic contents.

Marco Aurel's book includes several chapters about algebra's rule (called also: "regla de la cosa" or "arte mayor"). In particular, chapter 14 includes eight equalisations to solve algebra problems. Resolution of quadratic equations can be deduced as a specific case from 5 of them. The general rules given by the author for these five ones are:

- Equalisation 1: if two quantities, characters or differences of names are equalled and there is none missing between them, you should divide the smaller into the larger and this quotient is the solution (cosa). Therefore, a particular case of this rule is the solution of the incomplete quadratic equation:  $ax^2 = bx$  (in current notation). And the only solution given is  $x = \frac{b}{a}$ .
- Equalisation 2: if two quantities or differences of names are equalled and there is one missing between them, you should divide the smaller into the larger and this quotient is the value of a censo (square) and the square root of this quotient is the solution (cosa). Therefore, this rule gives the solution of the incomplete quadratic equation  $ax^2 = c$  (in current notation), and the only solution given is  $x = \sqrt{\frac{c}{a}}$ .

Aurel also specified that if we equal two quantities of the same quantity and gender like  $4x^2 = 4x^2$ , then the solution is always 1, but if we equal  $4x^2 = 5x^2$ , this would be impossible.

- Equalisation 5: if three quantities or differences of names equally distant are equalled and there is none missing among them, and in particular, if the two larger ones are equal to the smaller. You should divide the smaller and the middle one into the larger, then you should multiply half the quotient of the middle one into the larger by itself and to this product you should add the quotient of the smaller between the larger. The root of all this sum minus half the quotient of the middle one is the solution (cosa). In today's notation, this rule solves the following complete second degree equation:  $ax^2 + bx = c$ . And the only solution given is:

$$x = \sqrt{\frac{b^2}{4a^2} + \frac{c}{a}} - \frac{b}{2a}$$

- Equalisation 6: if three quantities or differences of names equally distant are equalled and there is none missing between them, and in particular, if the larger and the smaller ones are equal to the intermediate value. You should divide the smaller and the middle one into the larger one, then you should multiply half the quotient of the middle one into the larger by itself and from this product you should subtract the quotient of the smaller into the larger one. The root of all this subtraction plus or minus half the quotient of the intermediate value into the larger is the solution (cosa). In today's notation, this rule solves the following complete second degree equation:  $ax^2 + c = bx$ . And the solutions given are:

$$x = \sqrt{\frac{b^2}{4a^2} - \frac{c}{a}} \pm \frac{b}{2a}$$

The author included different comments about this equalisation.

For example, if  $\sqrt{\frac{b^2}{4a^2} - \frac{c}{a}} - \frac{b}{2a}$  is impossible, because  $\sqrt{\frac{b^2}{4a^2} - \frac{c}{a}} < \frac{b}{2a}$ , then you should solve:

$$\frac{b}{2a} - \sqrt{\frac{b^2}{4a^2} - \frac{c}{a}}$$

The author clarified that most of the questions solved by this equalisation have two answers. And he indicated the following comment to decide if it is better to remove or to add the root  $\sqrt{\frac{b^2}{4a^2} - \frac{c}{a}}$ : if the quantity of the middle character is greater than the quantity of the smaller one, you will add the root to half the quotient of the middle one and if it is less than the smaller quantity you will remove the root of the middle quotient. The rest is left to the judgement of the solver.

Marco Aurel also warned that if the quotient of the smaller character is greater than the power of half of the middle one, so that you cannot remove it, you should add it, and then you should make its root and then add to it half of the middle one, but this value will be less or debt.

- Equalisation 7: if three quantities or differences of names equally distant are equalled and there is none missing between, and in particular, if the two smaller ones are equal to the larger. You should divide the smaller and the middle one into the larger one, then multiply half the quotient of the middle value into the larger by itself and to this product you should add the quotient of the smaller into the larger one and then, the root of all this sum plus half the quotient of the middle value is the solution (cosa). In today's notation, this rule solves the following complete second degree equation:  $ax^2 = bx + c$ . And the only solution given is:

$$x = \sqrt{\frac{b^2}{4a^2} + \frac{c}{a}} + \frac{b}{2a}$$

Also in 1552, Gonçalo Busto (1552) printed in Seville a new edition of Juan de Ortega's treatise, whose first edition was printed in 1512, and he added thirteen solved problems about algebra. These problems included some cases of quadratic equations (in today's notation):

- For  $x^2 + bx = c$ , the solution given is  $x = \sqrt{\frac{b^2}{4} + c} - \frac{b}{2}$ .
- For  $ax^2 = c$ , the only solution given is  $x = \sqrt{\frac{c}{a}}$ .

In *Arithmetica practica, y speculativa* written by Juan Pérez de Moya (Perez de Moya, 1562), we can find similar algebraic ideas to the ones in Marco Aurel. Although as Meavilla and Oller (2014) state, the algebraic symbolism that appears in these books is not the same. Considering the resolution of quadratic equations, Pérez de Moya included comments like: If the two parts of the equalisation are similar in characters and number, in current notation for quadratic equations  $ax^2 = ax^2$ , the solution is 1. If they were similar in characters and different in number as  $ax^2 = bx^2$ , these questions are impossible. If they are similar in number and dissimilar in characters as  $8x = 8x^2$ , these have infinite answers and do not have only one. And if they are dissimilar in number and character as  $5x = 8x^2$ , they have only one solution.

Pérez de Moya considered 7 equalisations, and he divided them into simple and compound. First and second simple equalisations are in line with what we previously said for Marco Aurel's first and second equalisations. First, second and third compound equalisations are in line with what we previously said for Marco Aurel's fifth, sixth and seventh equalisations (respectively).

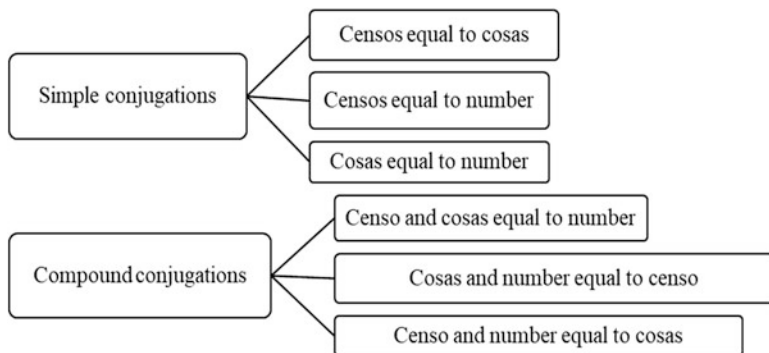
Perez de Moya's comments for second compound equalisations (in current notation  $ax^2 + c = bx$ , and roots  $x = \sqrt{\frac{b^2}{4a^2} - \frac{c}{a} \pm \frac{b}{2a}}$ ), said that the root of the subtraction  $\frac{b^2}{4a^2} - \frac{c}{a}$  can be added or subtracted to half of the middle value to obtain the solution, these equalisations have in most cases two answers and in order to know if it will be better to add the root of the half of the middle or to subtract it, you will consider: If the middle character is greater than the smaller one, then you should add. And if the minor is greater than the middle one, then you should subtract.

He also said that if the quotient of the smaller one is greater than the square of half of the middle one, so you cannot remove these quantities, you should add them together and the root of that plus half of the middle one will be the solution. So, it is in line with Marco Aurel's comments.

This is not the only book published by Pérez de Moya that included algebraic contents. For example, *Tratado de Mathematicas* by Perez de Moya (1573) included again algebra (regla de la cosa), and it expanded what was already told in the previous one, although it included some minor modifications. For example, when he spoke about equalisations that are composed of different characters but had similar quantities, like 10 censos to 10 cosas ( $10x^2 = 10x$ ), he said that such a question has several answers and not just one.

The book *Arithmetica* by Antich Rocha included algebraic contents briefly (Rocha, 1564), he repeated the notices included by Perez de Moya (1562) about





**Fig. 4.2** Scheme of conjugations proposed by Pedro Nuñez (1567, p. 1)

similar or not similar characters with similar or not similar numbers and he indicated that for the equalisations he would follow Marco Aurel.

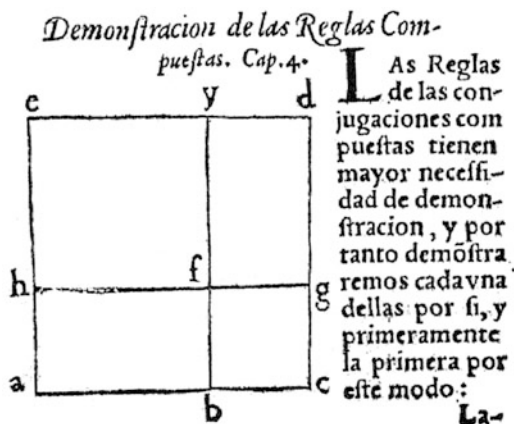
*Libro de Algebra en Arithmetica y Geometria* written by Pedro Nuñez and published in 1567 included algebraic contents and he posed this scheme (Fig. 4.2):

He included a rule for each one of these conjugations, considering only quadratic equations:

- Censos equal to cosas (in current notation  $ax^2 = bx$ ) We shall divide the number by  $x$  (cosas) into the number by  $x^2$  (censos) and that shall be the unknown value (cosas). So  $x = \frac{b}{a}$ .
- Censos equal to numbers (in today's notation  $ax^2 = c$ ) We shall divide the number into the number by  $x^2$  (censos). The root of this partition shall be the unknown value (cosas). So  $x = \sqrt{\frac{c}{a}}$ .
- Censo and cosas equal to number (in current notation  $x^2 + bx = c$ ): We shall multiply half of the number of  $x$  (cosas) by itself and add the number. From this sum we shall take the root and to the result we shall subtract half of the number of  $x$  (cosas) and that shall be the unknown value. So  $x = \sqrt{\frac{b^2}{4} + c} - \frac{b}{2}$ .
- Cosas and number equal to censo (in today's notation  $x^2 = bx + c$ ): We shall multiply half of the number of  $x$  and add the number. To all this sum we shall take the root and put it together with half the number of  $x$  and the sum shall be the unknown value.  
So  $x = \sqrt{\frac{b^2}{4} + c} + \frac{b}{2}$ .
- Censo and number equal to cosa ( $x^2 + c = bx$  in today's notation): We shall multiply half the number of  $x$  and subtract the number. From what is left we shall take the root and add it with half the number of  $x$ , or subtract it if we want, and it shall give us the unknown value.  
So  $x = \sqrt{\frac{b^2}{4} - c} \pm \frac{b}{2}$ .

Pedro Nuñez included geometric demonstrations for these rules (Fig. 4.3), which were not included by the previous ones.

**Fig. 4.3** Proof of the compound rules (Nuñez, 1567, p. 6b)



### Seventeenth Century Books

The first seventeenth century book that we considered was published by Juan Bautista Tolra in 1619. It was a translation into Spanish of *Arismetica* by Joan Ventallol and Tolra included also *Tratado de la Arte mayor*, a treatise about algebra. When he talked about equalisations, he said that he follows Marco Aurel and Rocha and he considered 8 equalisations, so we found no relevant differences among them (Tolra, 1619).

Joseph Zaragoza published in 1669 *Arithmetica Universal* (Zaragoza, 1669), he included resolution of quadratic equations in a different form if we compared it with the previous authors. Notation was also different, for example Zaragoza wrote:  $1z^2 + 9z^1 \Omega 90$  (in today's notation  $x^2 + 9x = 90$ ).

First, this author speaks about different questions, for example: If a quantity is found equal to itself as  $6z^2 + 4z = 6z^2 + 4z$ , this equation is useless, and this could be for three reasons:

- Because there are not enough terms in the question to obtain a suitable equation.
- Because any number can solve the question, and in this case is not useless, since it already determines the truth, and in geometrical questions it is very useful.
- Because not all the circumstances of the question have been well examined, and so it is convenient to re-examine it.

Once a equalisation has been reduced, the author said that: if the character is a single one and its exponent is two, the quantity is divided into the number of the character and the square root is taken. So for:

$$az^2 = c, \quad z = \sqrt{\frac{c}{a}}.$$

If there are two characters in a equalisation and the greater exponent is twice the smaller one, first the square root of the number of the character is taken. Then to the square of the number of the minor character, add or subtract the quadruple of the quantity, according to the sign of the major character. Once the square root of the sum or subtraction has been taken, if the minor character has a plus sign, the difference of its number and this root will be taken, and if it has a minus sign, the sum will be taken. And half of this difference or sum is the value of the minor character.

So, in today's notation for  $az^2 + bz = c, z = \frac{\sqrt{b^2 - 4c - b}}{2}$ .

He also clarifies, that if the major character has a minus sign, the minor character will have two values, sometimes the two values satisfy the question, sometimes only one, and this have to be examined.

In *Arithmetica especulativa, y practica y arte de algebra* by Andrés Puig (1672) in chapter 6 quadratic equations are included. He solved them without major changes with respect to the sixteenth century books.

Among his comments, if the equalisation is compound, he said that there is much to be said, because of the great difficulty to be able to explain it and comprehend it well.

The author explained also particular situations, as if  $\frac{b^2}{4a^2} - \frac{c}{a} = 0$  the solution is  $\frac{b}{a}$ . Or if  $\frac{b^2}{4a^2} - \frac{c}{a}$  cannot be calculated, the situation is impossible.

### ***Eighteenth Century Book***

The first considered book from the 18th century is *Elementos Mathematicos* by Pedro de Ulloa (1706). This book included several ideas for quadratic equations, for example, this scheme about the roots (Fig. 4.4):

Then he included the value of these roots (Fig. 4.5):

And he said that the proof of them is easy, and in order to do so, he used the square of a binomial and therefore, the technique of completing the square (although without saying it). He also considered impossible situations.

*Compendio mathematico* was written by Vicente Tosca (1709). In his book, Tosca included a treatise on algebra or analytical art with different theorems, propositions and corollaries to solve quadratic equations.

$$\begin{array}{c}
 \text{SEGUNDO GRADO.} \\
 \text{I.}^a \qquad \qquad \qquad \text{II.}^a \qquad \qquad \qquad \text{III.}^a \\
 -a \sim 0 . x - b \sim 0 \mid x + a \sim 0 . x + b \sim 0 . \mid x - a \sim 0 . x + b \sim 0 . \\
 x^2 - ax - bx + ab \sim 0 \mid x^2 + ax + bx + ab \sim 0 \mid x^2 - ax + bx - ab \sim 0 ;
 \end{array}$$

Fig. 4.4 Ulloa's scheme of roots (de Ulloa, 1706, p. 130)

**Fig. 4.5** Ulloa's scheme of values for the roots (de Ulloa, 1706, p. 130)

$$\begin{array}{l}
 \text{I.}^a \quad x^2 + px + q = 0. \quad x = \frac{1}{2}p + r \sqrt{\frac{1}{4}p^2 - q} \\
 \text{II.}^a \quad x^2 + px - q = 0. \quad x = \frac{1}{2}p + r \sqrt{\frac{1}{4}p^2 + q} \\
 \text{III.}^a \quad x^2 - px + q = 0. \quad x = \frac{1}{2}p - r \sqrt{\frac{1}{4}p^2 - q} \\
 \text{IV.}^a \quad x^2 - px - q = 0. \quad x = \frac{1}{2}p - r \sqrt{\frac{1}{4}p^2 + q}
 \end{array}$$

La Demostracion de estos valores es facil.

Tosca explained first the particular case: if after reducing a equalisation (following the previous propositions), the character of the unknown is found to be equal to a known quantity, and this character has as exponent 2, the square root of the known number will be the number required.

Then for compound analysis, the introduction shows this theorem: If we have the two given quantities a and b, and we assume that  $x = a$  and  $x = b$ . By antithesis,  $x - a = 0$  and  $x - b = 0$ , if we multiply these equations, the product is  $xx - xa - xb + ab = 0$ , and a and b are the roots. As a corollary, he concluded that second degree equations can have two roots, and these can be both positive, both negative or one of each.

To solve them, he considered different resolution methods. One of them is partition by Monsignor Juan Prester: considering that the last term is the product of the roots, or values of the unknown, it is certain that some of its divisors will be the roots. Look for all the divisors of the last term and see if the unknown plus or minus each divisor can divide it exactly; the divisor that will make the division exact, will give a root of the equalisation. If no partition comes exactly, the equalisation will not have a commensurable root. He also explained the relation between the signs of the numbers and the signs of the roots.

Then he explained another method: substitution, posed by Rolle, which according to Tosca is easier. This method consisted on substituting different known quantities in place of the unknown quantity, until the root is found.

He also considered the Method of Hypothesis. These hypotheses are numbers chosen to find the value of the unknown quantity by substituting them in place of each other in compound equalizations.

The book *Arithmetica especulativa, y practica, y Arte mayor, o Algebra* written by Francisco Xavier Garcia (1733) explained simple and compound equalisations like a dialogue between a teacher and his pupil. He included them in a similar way in notation and structure as the sixteenth century authors.

Pedro Padilla y Arcos included in his third volume of *Curso militar de mathematicas* (Padilla, 1756) a treatise on algebra, where he talked about second-degree equations. To solve these equations, first he explained how to leave the equation in the form:  $x^2 + bx = c$ .

If the unknown has first and second terms, you should add to both parts the square of half the quotient of the second term, so the part of the unknown is a perfect square. Extracting the square root from both parts, the equation will be reduced to a first degree equation and it will be solved by the rules of these. The author considered

both roots, and the solutions will be real or imaginary depending on the value of the root.

Thomas Cerda included in his second volume of *Liciones de Mathematica, o Elementos generales de Arithmetica y álgebra para el uso de la clase* (1758) some pages dedicated to second degree equations. In them, he differentiated between simple quadratic equation, like  $x^2 = ab$  whose value the author considered easy, in particular,  $x = \sqrt{ab}$ ; and complete quadratic equations. For them, he included a universal rule with 4 steps:

1. Pass all the terms where the unknown and its square are found to one member and in the other member include all the known terms.
2. If the square of the unknown has any coefficients, remove them following the previously given rules.
3. Add to both members the square of half of the coefficient of the simple unknown, so the member of the unknown will be a perfect square.
4. Take the square root of both members and find the values (roots).

He said that the root of any negative quantity will be imaginary or impossible. And every quadratic equation has two solutions, either both real or imaginary, but no one real and one imaginary.

Benito Bails in the first volume of his book *Principios de matemática* (1776) included a specific article dedicated to second degree equations. He defined them as every equation whose unknown is raised to the second power and he differentiated three cases:

- If the equation only includes the square of the unknown:  $xx - bb = cc$ , Bails said that the resolution is very easy and the solution is:  $x = \pm \sqrt{bb + cc}$
- If, in addition to the square of the unknown, the equation also includes the first power as  $xx + ax = bb$ , the value of the unknown is not obtained so quickly. However, he said that this operation has no difficulty if it is considered the formation of the square of a binomial (for example, the square of  $x + a$  is  $xx + 2ax + aa$ ).

And to solve it, he explained how to prepare the equation to obtain the previous form. Then in order to make a complete square in the member of the equation where the unknown is, you should add to both members the square of half the coefficient that carries the first power of the unknown. Finally, the square root of each member is taken and then the values are found.

Bails manifested that these questions give two solutions, that can be both positives, one positive and the other negative (and for this, the problem is solved in the opposite terms), but if both resolutions are negative, it is a sign that it is badly proposed and that it must be posed with contrary conditions.

Also, the author said that a question is impossible when the value of the unknown is some impossible quantity of the form  $\sqrt{-aa}$ .

*Elementos de matemática* by Benito Bails (1779) included several sections on this topic, similar to his previous book.

First volume of *Elementos de matemática pura* by Carlos Le-Maur (1778) included a specific part about quadratic equations, where he considered different resolution methods:

- The method of successively substituting in place of the unknown factors of the last term of the equation, until we find one that satisfies the equation. The author said that this method is safe, but it seems to act by doubting, and it does not resolve the question in general terms.
- Therefore, he proved that for the equation  $x^2 + px + q = 0$  the values (roots) of the unknown are:

$$x = -\frac{1}{2}p + \left(\frac{1}{4}p^2 - q\right)^{\frac{1}{2}} \quad \text{and} \quad x = -\frac{1}{2}p - \left(\frac{1}{4}p^2 - q\right)^{\frac{1}{2}}$$

Among his comments, he analysed the different situations when the roots are positive or negative, imaginary, etc. and he also considered incomplete equations.

*Elementos de Algebra, o sea reglas generales para encontrar lo que vale la incognita en las ecuaciones de el primero, y segundo grado, en quienes no haya termino irracional, y resolucion de setenta y quatro problemas, distribuido todo en veinte y tres Dialogos* was published by Ventura de Abila (n.d.-b). In his dialogue 97 he included a general rule to find the two values of quadratic equations if there is no irrational term.

He first indicated how to reduce the equation to the form  $n^2 = bn + c$  and then to obtain the values, he included the following steps:

You should multiply half the coefficient of the simple unknown by itself. To this product, you should add the known term, and from this sum you would get the square root. Then, to half of the coefficient of the simple unknown add the square root and the sum will be the value of the unknown in the given equation. Also, to half the coefficient of the simple unknown, subtract the square root and the difference will be the other value of the unknown in the given equation.

$$n = \frac{b}{2} \pm \sqrt{\frac{b}{2} \cdot \frac{b}{2} + c}$$

In his book *Aplicación del Algebra a la regla de tres simple, directa, e indirecta; a la de tres compuesta; a la de compañías sin tiempo; y con el; al interes simple, al interes compuesto; y a las aligaciones*, Ventura de Abila (n.d.-a) mentioned dialogue 97 to solve problems that involve quadratic equations.

A similar rule to the one in dialogue 97, it is included in *Reglas generales que de la arithmetica numerica y literal, de la formacion de potencias, y extraccion de raíces de cantidades numericas, y literales, y de la algebra* (de Avila, 1780). In this occasion, the author included: note that these two values can be equal.

Juan Justo García in *Elementos de aritmética, álgebra y geometría* (1782) included different chapters on algebra, among them one about quadratic equations.

He indicated that the resolution of equations where the unknown is raised to its square, depends on four rules:

- 1st. Put in one member all the terms where the unknown is found, but in such a way that the one containing the square of the unknown is 1.
  - 2nd. If the square is complete (if there were no more terms with the unknown than the square of the unknown), take the square root of both members and you will find the unknown.
  - 3rd. If the square is incomplete (if in addition to the square of the unknown, there are one, two or more terms with it), you should add to both members the square of half the quantity or quantities that multiply the first power of the unknown.
  - 4th. You should take the square root of both members and you can find the values.
- He added some comments like that the 3rd rule is due to the three terms of which the square of a binomial consists.

About the values, he said that every quadratic equation has two unknown roots or values, and if the quantities obtained are negative, the problem is solved in the opposite direction. Also, he considered imaginary quantities absurd or impossible, so if the result of the solution of a problem is an imaginary root, the problem will be impossible.

Jayme Conde included in *Rudimentos de algebra* (1782) a section on second degree equations with only one unknown. He indicated that for equations like  $ax^2 = c$ , the values will be  $x = \pm \sqrt{\frac{c}{a}}$ . These values of the quadratic equations can be positive or negative, but if the square root is negative ( $\frac{c}{a} < 0$ ), the problem is impossible.

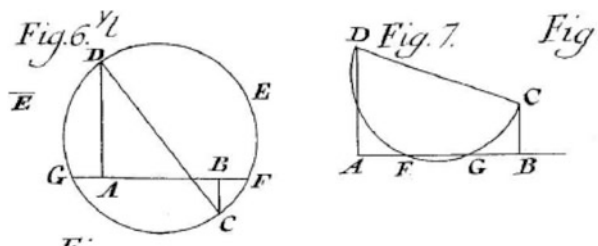
To solve complete quadratic equations, the equation must be prepared so it has the form:  $ax^2 + bx = c$ . Then you should add to each member of the equation the square of half of the known quantity which multiplies  $x$  in the second term, this will result in a perfect square of the first member, then you should take the square root of both members (considering that the square root of the second member can be both positive and negative) and you will find the unknown values.

Pedro Giannini (1782) included in the second volume of his *Curso matematico para la enseanza de los caballeros cadetes del Real Colegio Militar de Artilleria* the resolution of quadratic equations. To find the roots of the second degree equation  $x^2 + ax = bc$  when the known quantities  $a$ ,  $b$  and  $c$  are either positive or negative, you should add to the two members of the equation the square of the semi-coefficient of the second term, then the square root of both members is extracted and the solution is obtained.

$$x = -\frac{a}{2} \pm \sqrt{bc + \frac{a^2}{4}}$$

The author indicated that these solutions can be negative, positive or imaginary. He includes as a corollary the solution of the incomplete equations ( $x^2 = bc$  and  $x^2 + ax = 0$ ) with their two right values.

**Fig. 4.6** Geometric construction for two second degree equations (Giannini, 1782, p. 336)



Giannini (1782) also included the geometric construction of different second degree equations, as it is shown for example in Fig. 4.6.

Antonio Gregorio Rosell published in 1785 the first volume of *Instituciones matemáticas* (Rosell, 1785). Here he said that the values of the unknown for equations like  $ax^2 = c$ , will be  $x = \pm \sqrt{\frac{c}{a}}$ . For equations like  $x^2 + cx = e$ , where  $c$  and  $e$  represent any positive or negative quantity, he considered the square of a binomial, and therefore, by adding  $\frac{1}{4}c^2$  in both terms and doing the square root, you will find the values. The formula is:  $x = -\frac{1}{2}c \pm \sqrt{\frac{1}{4}c^2 + e}$ .

He made a comment about the two values of the unknown: To know which one of these values is the one sought, or if both are useful, it is necessary to know the circumstances of the question. Also he thought about the possible values of the unknown: real, equal or unequal, ... And also imaginary if  $e < 0$  and  $e > 1/4c^2$ . In this situation, the author said that it will be impossible to find what is required.

*Elementos de aritmética y álgebra* (Poy y Comes, 1786) included a general rule to find the two values that the unknown has in any second degree equation with no irrational term. First he gave several steps to put the equation in the form  $x^2 = ax + b$ . Then he said, that you should square half the coefficient of the single unknown, you should add the previous number to the known term, you should take the square root of that sum and if you add half of the coefficient of the simple unknown with the previous square root, you will get the first value of the unknown. If you subtract it, you will have the second value.

Four years later, *Llave aritmética y algebrayca* written also by Manuel Poy y Comes (1790) was published. The text was written as questions and answers and the following question is included: How will you find the two values that the unknown has in any second degree equation with no irrational term? The answer given includes the same 13 steps that Poy y Comes (1786) explained.

*Compendio de Matemáticas puras y mixtas para instruccion de la juventud* written by Francisco Verdejo (1794) included several pages about quadratic equations and their resolution.

He divided quadratic equations into simple and compound equations and he said that the unknown of these equations must have two values. Simple equations ( $x^2 + a = c$ ) are solved by extracting the square root of the two members  $x = \pm \sqrt{c - a}$ .

Compound quadratic equations ( $x^2 + ax + b = c$ ) are divided into complete and incomplete. Complete quadratic equations are those equations in which the member



with the unknown terms is a perfect square or can become one only with the transposition of some terms. These are solved easily, by extracting the square root of each member and then making the necessary transposition so that the unknown remains alone in one of the members.

Incomplete ones are those equations in which it is not possible to make the member in which the unknown is found a perfect square without the addition of some quantity. These are solved by adding to each of the members half the coefficient that multiplies the first power of the unknown, raises it to the second power, then the equation will be complete.

Tadeo Lope y Aguilar wrote *Curso de matemáticas: para la enseñanza de los caballeros seminaristas del Real Seminario de Nobles de Madrid* (Lope y Aguilar, 1794). This author said that for solving quadratic equations, you should put in one member of the equation all the unknown terms, and you should remove the coefficient of the square of the unknown. Then you should prepare the member where the unknown is found, so that it is a perfect square. The author explained how to do this last step, he demonstrated it, and he indicated that a quadratic equation always has two roots, which can be real or imaginary.

## Discussion

Research on the history of mathematics and mathematics education allows knowing more about the evolution of mathematical knowledge in different countries and social circumstances and books are one of the main primary sources for this research.

In 1552 the first Spanish printed book with algebraic contents was published. Since then, many authors have included this kind of content. The previous analysis shows that quadratic equations were a relevant topic in Spain, included by all the authors considered in these 27 books.

The results show how the resolution of quadratic equations in Spanish mathematics books evolved in many aspects: in notation as stated for example by Meavilla and Oller (2014), but also in considerations and approach. For example, Marco Aurel included the solution of quadratic equations as particular cases of his 8 equalisations. And he posed their solution as steps to follow (square a term, add, subtract, . . .). In 4 of the 5 equalisations here analyzed, he calculated only one root for the quadratic equation, and he considered negative roots impossible. With minor changes, these ideas are also shared by other authors like Perez de Moya, Rocha, Pedro Nuñez, Tolra or Francisco Xavier Garcia (the latter in the eighteenth century).

Resolutions using the square of a binomial (completing the square technique) are the most common approach in the eighteenth century, for example in Ulloa, Giannini, Bails, Lope y Aguilar, Verdejo or Juan Justo Garcia. However, not all the authors mentioned explicitly this concept (square of a binomial).

Other eighteenth century authors like Tosca or Le-Maur included substitution methods. And authors like Poy y Comes or Ventura de Avila, maybe because of the

nature of their books, gave the solutions as steps to follow (square a term, add, subtract, . . .).

Furthermore, the comments and notices included by some authors show interesting ideas in order to understand how algebraic thought has evolved. For example Marco Aurel did not consider the null solution for quadratic equations like  $ax^2 = bx$  or  $ax^2 = bx^2$ , included some mistakes, etc.

Through these books, we can examine the changes in the number of roots considered for quadratic equations and in its nature, for example, negative roots are not considered by some authors, above all sixteenth century ones. Also, square roots of negative numbers received different treatments in these books, for example Giannini talked about imaginary roots like  $a + \sqrt{-b}$  and  $a - \sqrt{-b}$ .

To sum up, this study shows the progressive journey through the resolution of second degree equations in Spain, showing different approaches, methods of resolution, notation, obstacles, etc. In the following centuries and until our days, systematic study of quadratic equations was and is a relevant part of the teaching and learning of mathematics and therefore, it is included in many mathematics books, as it is shown for example in *Tratado elemental de algebra* (Cortázar, 1866).

## Conclusions

The role of the history of mathematics and mathematics education in the mathematics classroom has been considered by many researchers (Chorlay et al., 2022). Fauvel (1991) mentions several arguments for using history in mathematics education, for example, it can increase motivation, it gives mathematics a human face, it can help understanding by showing how concepts have developed, it can help to value modern techniques, etc. He also presented some ways of using history in mathematics education: provide historical anecdotes, make exercises using mathematical texts from the past, set projects about local mathematical activity in the past, use examples from the past to explain methods, explore past mistakes to help understanding and solving difficulties, etc. Jankvist (2009) proposes two categories to structure the arguments for the use of history in teaching and learning mathematics: history as a tool and history as a goal, and three categories to organize the ways of using: the illumination, the modules, and the history-based approaches.

In particular, Jahnke et al. (2002) consider the study of original sources a value activity by which historical aspects might be integrated into the teaching and learning of mathematics. Also, Guillemette (2017) and Guillemette and Radford (2022) value the contact with the history of mathematics, particularly with the use of original sources, in the context of mathematics teachers' training.

In the field of algebra, different authors propose the possibilities of its history in mathematics instruction. For example, Meavilla and Oller (2014) present activities for trainee secondary school teachers in which they should compare and assess the old algebraic symbolism in relation to the one used today; Frejd (2013) carries out a

comparative analysis of five old algebra books published in Sweden between 1794 and 1836, and he identifies historical features that can help teachers and students in the process of teaching and learning mathematics; Guevara-Casanova and Burgués-Flamarich (2018) use the methods of Liu Hui and al-Khwārizmī, and they identify evidences showing that the teaching of algebra in the classroom should start from geometry and problem solving and that the current method that moves from arithmetic to algebra, is a didactic problem inherited from our history; and Florio (2020) uses history of mathematics to help students to overcome the discontinuity, often perceived by them, between learning geometry and learning algebra; Puig and Rojano (2004) address some issues in algebra history from which ideas for the future of the teaching and learning of this field can be extracted. Nataraj and Thomas (2017) extract ideas from the history of algebra for developing classroom teaching practices involving variables and exponents. Barbin (2022) proposes introducing the resolution of quadratic equations by completing squares throughout one school year, then waiting until the next course to introduce the resolution by using the usual formula and, finally the comparison of constructions of geometric figures in Pedro Nunes, Françoise Viète and René Descartes' original texts.

Considering what for example Madrid et al. (2021) say about the common lack of knowledge about the history of mathematics, our study provides useful examples to use in the mathematics classroom, for example to compare old and modern methods in order to value modern ones, to understand the evolution of the algebraic thinking and past obstacles and mistakes or to generate meaningful debates between students, for example between trainee mathematics teachers. Also, this ethnomathematical approach could help to show mathematics in the Spanish context, which brings this discipline closer to the students (Meaney et al., 2021).

**Acknowledgments** This study has been carried out within the research project of the Plan I + D + i of Spanish Ministry of Economy and Competitiveness (FEDER Funds) EDU2016-78764-P.

## References

- Ageron, P., & Hedfi, H. (2020). Ibrāhīm al-Balīshṭār's book of arithmetic (ca. 1575): Hybridizing Spanish mathematical treatises with the Arabic scientific tradition. *Historia Mathematica*, 52, 26–50. <https://doi.org/10.1016/j.hm.2020.01.002>
- Aurel, M. (1552). *Libro primero, de Arithmetica Algebraica*. Casa de Ioan de Mey Flandro.
- Ausejo, E., & Medrano, F. (2012). La fundamentación del Calculus en España: el Cálculo Infinitesimal en Gabriel Ciscar (1760–1829). *Llull: Revista de La Sociedad Española de Historia de Las Ciencias y de Las Técnicas*, 35(76), 305–316.
- Bails, B. (1776). *Principios de matematica donde se enseña la especulativa, con su aplicacion a la dinámica, hidrodinámica, óptica, astronomía, geografia, gnomónica, arquitectura, perspectiva, y al calendario*. Joachin Ibarra.
- Bails, B. (1779). *Elementos de matemática. Tomo II*. Joachin Ibarra.
- Barbin, É. (2022). On the role and scope of historical knowledge in using the history of mathematics in education. *ZDM Mathematics Education.*, 54, 1597–1611. <https://doi.org/10.1007/s11858-022-01410-1>

- Beeley, P., Nasifoglu, Y., & Wardhaugh, B. (2020). *Reading mathematics in early modern Europe*. Routledge. <https://doi.org/10.4324/9781003102557>
- Boyer, C. (1968). *History of mathematics*. Wiley.
- Busto, G. (1552). *Tractado subtilissimo de Arismetica y de Geometria. . . de nuevo emendado. . . por Gonçalo Busto*.
- Cerda, T. (1758). *Liciones de mathematica, o elementos generales de arithmetia y algebra para el uso de la clase. Tomo I*. Francisco Suria.
- Chorlay, R., Clark, K. M., & Tzanakis, C. (2022). History of mathematics in mathematics education: Recent developments in the field. *ZDM Mathematics Education*, 54, 1407–1420. <https://doi.org/10.1007/s11858-022-01442-7>
- Christianidis, J., & Megremi, A. (2019). Tracing the early history of algebra: Testimonies on Diophantus in the Greek-speaking world (4th–7th century CE). *Historia Mathematica*, 47, 16–38. <https://doi.org/10.1016/j.hm.2019.02.002>
- Cifoletti, G. C. (2021). “New” early modern evidence for Jacob Klein’s theses. In B. Hopkins & J. Drummond (Eds.), *The new yearbook for phenomenology and phenomenological philosophy* (Special Issue: Gian-Carlo Rota and The End of Objectivity, 2019). Routledge. <https://doi.org/10.4324/9781003131250>
- Conde, J. (1782). *Rudimentos de algebra para facilitar la enseñanza de la Escuela Patriótica de la Real Sociedad Aragonesa de Amigos del Pais*. Blas Miedes.
- Cortázar, J. (1866). *Tratado de álgebra elemental*. Imprenta de Antonio Peñuelas.
- de Abila, V. (n.d.-a). *Aplicación del Algebra a la regla de tres simple, directa, e indirecta; a la de tres compuesta; a la de compañías sin tiempo; y con el; al interes simple, al interes compuesto; y a las aligaciones*. Francisco Suria y Burgada.
- de Abila, V. (n.d.-b). *Elementos de Algebra, o sea reglas generales para encontrar lo que vale la incognita en las ecuaciones de el primero, y segundo grado, en quienes no haya termino irracional, y resolucion de setenta y quatro problemas, distribuido todo en veinte y tres Dia*. Francisco Suriá y Burgada.
- de Avila, V. (1780). *Reglas generales que de la arithmetica numerica y literal, de la formacion de potencias, y extraccion de raíces de cantidades numericas, y literales, y de la algebra*. Francisco Moreno.
- de Ulloa, P. (1706). *Elementos mathematicos* (1st ed.). Antonio Gonçalez de Reyes.
- Fauvel, J. (1991). Using history in mathematics education. *For the Learning of Mathematics*, 11(2), 3–6.
- Fauvel, J., & Gray, J. (1991). *The history of mathematics: A reader*. Open University.
- Florio, E. (2020). A synergy between history of mathematics and mathematics education: A possible path from geometry to symbolic algebra. *Education Sciences*, 10(9), 243. <https://doi.org/10.3390/educsci10090243>
- Frejd, P. (2013). Old algebra textbooks: A resource for modern teaching. *BSHM Bulletin: Journal of the British Society for the History of Mathematics*, 28(1), 25–36. <https://doi.org/10.1080/17498430.2012.676963>
- García, F. X. (1733). *Arithmetica especulativa y practica y arte mayor o algebra*. Imprenta Real de Luis de Cueto.
- García, J. J. (1782). *Elementos de aritmetica, álgebra y geometría*. Joaquín Ibarra.
- García, D. (2015). Jorge Juan: el introductor del Cálculo Infinitesimal en España. *Suma: Revista Sobre Enseñanza y Aprendizaje de Las Matemáticas*, 79, 53–63.
- Giannini, P. (1782). *Curso matematico para la enseñanza de los caballeros cadetes del Real Colegio Militar de Artillería. Tomo II*. Don Antonio Espinosa.
- Gray, J. (2010). *A history of abstract algebra*. Springer.
- Guevara-Casanova, I., & Burgués-Flamarich, C. (2018). Geometry and visual reasoning. In K. Clark, T. Kjeldsen, S. Schorcht, & C. Tzanakis (Eds.), *Mathematics, education and history. ICME-13 monographs* (pp. 165–192). Springer. [https://doi.org/10.1007/978-3-319-73924-3\\_9](https://doi.org/10.1007/978-3-319-73924-3_9)

- Guillemette, D. (2017). History of mathematics in secondary school teachers' training: Towards a nonviolent mathematics education. *Educational Studies in Mathematics*, 96(3), 349–365. <https://doi.org/10.1007/s10649-017-9774-3>
- Guillemette, D., & Radford, L. (2022). History of mathematics in the context of mathematics teachers' education: A dialogical/ethical perspective. *ZDM Mathematics Education*, 54, 1493–1505. <https://doi.org/10.1007/s11858-022-01437-4>
- Jahnke, H. N., Arcavi, A., Barbin, E., Bekken, O., Furinghetti, F., El Idrissi, A., da Silva, C. M. S., & Weeks, C. (2002). *The use of original sources in the mathematics classroom* (pp. 291–328). [https://doi.org/10.1007/0-306-47220-1\\_9](https://doi.org/10.1007/0-306-47220-1_9)
- Jankvist, U. T. (2009). A categorization of the “whys” and “hows” of using history in mathematics education. *Educational Studies in Mathematics*, 71(3), 235–261. <https://doi.org/10.1007/s10649-008-9174-9>
- Katz, V. J. (2009). *History of mathematics*. Pearson.
- Koley, S. (2022). Geometrical contribution of ŚRĪDHARĀCĀRYA. *Science and Culture*, 88(3–4), 101–107. <https://doi.org/10.36094/sc.v88.2022>
- Le-Maur, C. (1778). Elementos de matemática pura. Tomo primero. Aritmética universal. .
- León-Mantero, C., Santiago, A., & Gutiérrez-Arenas, M. P. (2020). El método de máximos y mínimos en los libros de texto españoles del siglo XVIII: influencias europeas. In C. López-Esteban & A. Maz-Machado (Eds.), *Las matemáticas en España durante el siglo XVIII a través de los libros y sus autores* (pp. 115–133). Universidad de Salamanca.
- León-Mantero, C., Madrid, M. J., & Maz-Machado, A. (2022). La evolución de los métodos de resolución de triángulos oblicuángulos en los libros de texto sobre trigonometría publicados en España. In J. A. Fernández-Plaza, J. L. Lupiáñez, A. Moreno, & R. Ramírez (Eds.), *Investigación en Educación Matemática. Homenaje a los profesores Pablo Flores e Isidoro Segovia* (pp. 213–230). Octaedro.
- Lope y Aguilar, T. (1794). *Curso de matemáticas: para la enseñanza de los caballeros seminaristas del Real Seminario de Nobles de Madrid. Tomo I*. Imprenta Real.
- Madrid, M. J., Maz-Machado, A., León-Mantero, C., & López-Esteban, C. (2017). Applications of mathematics to everyday life in Spanish arithmetic books published in the 16th century, Aplicaciones de Las Matemáticas a la Vida Diaria en Los Libros de Aritmética Españoles del Siglo XVI. *Bolema - Mathematics Education Bulletin*. <https://doi.org/10.1590/1980-4415v31n59a12>
- Madrid, M. J., León-Mantero, C., Maz-Machado, A., & López-Esteban, C. (2019a). El desarrollo del concepto de ecuación en libros españoles de matemáticas del siglo XVIII. In J. M. Marbán, M. Arce, A. Maroto, J. M. Muñoz-Escolano, & Á. Alsina (Eds.), *Investigación en Educación Matemática XXIII* (pp. 403–412). Universidad de Valladolid.
- Madrid, M. J., Maz-Machado, A., López, C., & León-Mantero, C. (2019b). Old arithmetic books: Mathematics in Spain in the first half of the sixteenth century. *International Electronic Journal of Mathematics Education*, 15(1), em0553. <https://doi.org/10.29333/iejme/5935>
- Madrid, M. J., León-Mantero, C., & López-Esteban, C. (2020). El tratamiento del álgebra en los libros de matemáticas en castellano en el siglo XVIII. In C. López-Esteban & A. Maz-Machado (Eds.), *Las matemáticas en España durante el siglo XVIII a través de los libros y sus autores* (pp. 199–221). Universidad de Salamanca.
- Madrid, M. J., Maz-Machado, A., Almaraz-Menéndez, F., & León-Mantero, C. (2021). Comparison between a modern-day multiplication method and two historical ones by trainee teachers. *Mathematics*, 9(4), 349. <https://doi.org/10.3390/math9040349>
- Magnaghi-Delfino, P., & Norando, T. (2019). How to solve second degree algebraic equations using geometry. In P. Magnaghi-Delfino, G. Mele, & T. Norando (Eds.), *Faces of geometry. From Agnesi to Mirzakhani* (Lecture Notes in Networks and Systems) (Vol. 88). Springer. [https://doi.org/10.1007/978-3-030-29796-1\\_11](https://doi.org/10.1007/978-3-030-29796-1_11)
- Maz, A. (2009). Investigación histórica de conceptos en los libros de matemáticas. In M. J. González, M. T. González, & J. Murillo (Eds.), *Investigación en Educación Matemática XIII* (pp. 5–20). Sociedad Española de Investigación en Educación Matemática, SEIEM.

- Maz, A., & Rico, L. (2015). Principios didácticos en textos españoles de matemáticas en los siglos XVIII y XIX. *Revista Latinoamericana de Investigación En Matemática Educativa*, 18(1), 49–76. <https://doi.org/10.12802/relime.13.1812>
- Meaney, T., Trinick, T., & Allen, P. (2021). Ethnomathematics in education: The need for cultural symmetry. In M. Danesi (Ed.), *Handbook of cognitive mathematics*. Springer. [https://doi.org/10.1007/978-3-030-44982-7\\_4-1](https://doi.org/10.1007/978-3-030-44982-7_4-1)
- Meavilla, V., & Oller, A. M. (2014). El simbolismo algebraico en tres álgebras españolas del siglo XVI. *Números*, 87, 59–68.
- Millán, A. (1991). Los estudios de Geometría Superior en España en el siglo XIX. *Llull, Revista de La Sociedad Española de Historia de Las Ciencias*, 14, 117–186.
- Nataraj, M. S., & Thomas, M. (2017). Teaching and learning middle school algebra: Valuable lessons from the history of mathematics. In S. Stewart (Ed.), *And the rest is just algebra*. Springer. [https://doi.org/10.1007/978-3-319-45053-7\\_8](https://doi.org/10.1007/978-3-319-45053-7_8)
- Neuendorf, K. A. (2002). *The content analysis guidebook*. Sage Publications.
- Neugebauer, O. (1957). *The exact sciences in antiquity*. Harper.
- Nuñez, P. (1567). *Libro de Algebra en Arithmetica y Geometria*. Herederos d'Arnoldo Birckman.
- Oaks, J. A. (2019). Proofs and algebra in al-Fārisī's commentary. *Historia Mathematica*, 47, 106–121. <https://doi.org/10.1016/j.hm.2018.10.008>
- Padilla, P. (1756). *Curso militar de mathematicas, sobre las partes de estas ciencias, pertenecientes al Arte de la Guerra. Tomo 3*. Imprenta de Antonio Marin.
- Paradis, J., & Malet, A. (1989). *La génesis del álgebra simbólica. Vol. 1. Los orígenes del álgebra: de los árabes al Renacimiento*. Promociones y Publicaciones Universitarias.
- Parshall, K. H. (2017). A plurality of algebras, 1200-1600: Algebraic Europe from Fibonacci to Clavius. *BSHM Bulletin: Journal of the British Society for the History of Mathematics*, 32(1), 2–16. <https://doi.org/10.1080/17498430.2016.125340>
- Perez de Moya, J. (1562). *Arithmetica practica, y speculativa*. Mathias Gast.
- Perez de Moya, J. (1573). *Tratado de Mathematicas*. Juan Gracian.
- Poy y Comes, M. (1786). *Elementos de aritmetica y algebra para la instruccion de la juventud*. Francisco Suria y Burgada.
- Poy y Comes, M. (1790). *Llave aritmetica y algebrayca*. Francisco Suria y Burgada.
- Puig, A. (1672). *Arithmetica especulativa, y practica y arte de algebra*. Antonio Lacavalleria.
- Puig, L. (2003). Historia de las ideas algebraicas: componentes y preguntas de investigación desde el punto de vista de la matemática educativa. In E. Castro (Ed.), *Investigación en educación matemática: séptimo Simposio de la Sociedad Española de Investigación en Educación Matemática* (pp. 97–108). SEIEM. <https://www.uv.es/puigl/granada03oral.pdf>
- Puig, L. (2022). Ideas of structure in the history of algebra and its teaching. In T. Rojano (Ed.), *Algebra structure sense development among diverse learners* (pp. 20–35). Routledge. <https://doi.org/10.4324/9781003197867>
- Puig, L., & Fernández, A. (2013). La Arithmetica Algebraica de Marco Aurel, primer álgebra impresa escrita en español. Preliminares para su estudio. In L. Rico, M. C. Cañadas, J. Gutiérrez, M. Molina, & I. Segovia (Eds.), *Investigación en Didáctica de la Matemática. Homenaje a Encarnación Castro* (pp. 143–150). Editorial Comares.
- Puig, L., & Rojano, T. (2004). The history of algebra in mathematics education. In K. Stacey, H. Chick, & M. Kendal (Eds.), *The future of the teaching and learning of algebra the 12th ICMI study* (pp. 187–223). Kluwer Academic Publishers. [https://doi.org/10.1007/1-4020-8131-6\\_8](https://doi.org/10.1007/1-4020-8131-6_8)
- Rey, J. (1934). *Los matemáticos españoles del siglo XVI*. Junta de Investigaciones Histórico-Bibliográficas.
- Rocha, A. (1564). *Arithmetica* (1st ed.). Casa de Claudio Bornat a la Águila Fuerte.
- Rosa, M., & Shirley, L. (2016). Introduction. In M. Rosa, U. D'Ambrosio, D. Clark, L. Shirley, W. V. Alanguí, P. Palhares, & M. E. Gavarrete (Eds.), *Current and future perspectives of Ethnomathematics as a program* (ICME-13 Topical Surveys). Springer. [https://doi.org/10.1007/978-3-319-30120-4\\_2](https://doi.org/10.1007/978-3-319-30120-4_2)
- Rosell, A. G. (1785). *Instituciones matemáticas. Tomo I*. Imprenta Real.

- Rouse Ball, W. W. (1960). *A short account of the history of mathematics*. Dover.
- Smith, D. E. (1958). *History of mathematics* (Vol. II). Dover.
- Tolra, J. B. (1619). *Arismetica de Ivan Ventallol*. Gabriel Roberto.
- Tosca, T. V. (1709). Compendio mathematico. In *Tomo II* (1st ed.). Antonio Bordazar.
- Vallhonestá, F. R., Massa Esteve, M. R., Guevara Casanova, I., Puig-Pla, C., & Roca-Rosell, A. (2015). P, teacher training in the history of mathematics. In É. Barbin, U. T. Jankvist, & T. Kjeldsen (Eds.), *Proceedings of ESU7 history and epistemology in mathematics education* (pp. 113–128). Danish School of Education.
- Verdejo, F. (1794). *Compendio de matemáticas puras y mixtas para instruccion de la juventud* (1st ed.). Viuda de Ibarra.
- Zaragoza, J. (1669). *Arithmetica universal que comprehende el arte menor, y maior, algebra vulgar, y especiosa*. Geronimo Vilagrassa.

# Part II

## History of Mathematics and Its Relation to Mathematical Education: Introduction

Peter Appelbaum and Sixto Romero

In general, historically, the dissemination of knowledge (Romero, 2020; Ramírez, 2009; Chartier, 1987) is transformed with the arrival of new techniques and the use of technologies; first, with the appearance of the printing press, the world revolutionizes the way in which it approaches scientific production, in general, and today the Internet has allowed us to approach mathematical knowledge that predisposes us to understand the world from a differently and access a scenario of information that was previously inaccessible.

Thus, for example, the (university) publishing field emerges, which must adapt to the new dynamics and manage to stabilize the loss of legitimacy and hegemony that (higher) education is experiencing. This situation has imposed a challenge on (higher) education to achieve its permanence in the field of scientific production, which constitutes not only the production of knowledge but also its dissemination, by articulating with the dynamics of contemporaneity and the appearance of a consumer society close to virtuality.

Knowledge is the conscious and intentional act to apprehend the qualities of the object and is primarily referred to the subject, the Who knows, but also to the thing that is its object, the What is known. Its development has been consistent with the evolution of human thought. Epistemology studies knowledge (Van Loon & Sarzano, 2016) and both are the basic elements of scientific research, which begins by proposing a hypothesis and then treats it with mathematical verification models and ends by establishing valid and reproducible conclusions. Scientific research has become an accepted and validated process to solve questions or new facts aimed at

---

P. Appelbaum  
Arcadia University, Glenside, PA, USA  
e-mail: [appelbap@arcadia.edu](mailto:appelbap@arcadia.edu)

S. Romero  
Universidad de Huelva, Huelva, Spain  
e-mail: [sixto@uhu.es](mailto:sixto@uhu.es)



knowing the principles and laws that sustain man and his world; It has its own systems based on the hypothesis-deduction/induction method complemented with statistical and probability calculations. Good management of the theory of knowledge in scientific research allows correct and technical answers to be given to any hypothesis, which is why the scientific researcher should know the theory and its evolution (Romero, 2020).

Mathematics is currently considered to be the most powerful social medium for planning, optimizing, directing, representing and communicating man-made social affairs. Through the development of modern information and communication technologies, based on mathematics, this social impact has come to reach its maximum splendor: mathematics is now used universally in all fields of society, and there is hardly any process of political decision making in which mathematics is not used as the rational argument and objective basis that replaces political judgments and power relations. For the ordinary citizen, however, it becomes more and more difficult and sometimes impossible to follow these developments in mathematics, mathematical applications and adequately evaluate their social use, since the specialization and segmentation of mathematical applications are often extremely difficult to understand. The main perception of its need and a basic knowledge of its importance in general are often confronted with a complete lack of knowledge of concrete examples of its impact. Competencies to evaluate mathematical applications, and their possible usefulness or problematic effects, however, are now a necessary precondition for political executive and democratic citizen participation. The new challenge is to determine what kind of knowledge about social knowledge is needed in a mathematized society and how to acquire the necessary constituents.

But what happens when we have to talk about the history of mathematics and its relationship with mathematics education? (De Guzmán, 2001; Siu & Tzanakis, 2004; Kjeldsen, 2011)

It seems clear that a profound change is taking place in the mathematical community, at least in terms of the assessment it makes of mathematical education. It is in this very significant aspect that in the new classification of fields and subjects that in 2000 the American Mathematical Society presented for use in the *Mathematical Reviews*, introducing for the first time a field entitled *Mathematical Education* with the same status as other fields of the Mathematics such as *Differential Equations*, *Mathematical Analysis*, *Differential Geometry*, . . . (De Guzmán, 2001).

The history of mathematics education (De Guzmán, 2001) has experienced great changes, not only in what is taught, but also in the way of teaching. There has been a wide variation in the value placed on mathematics and its position in education. The views of the public and of academic societies towards a predominantly mathematical or scientific education have, for the most part, been very different from those now held.

There are numerous questions that immediately come to mind. What Mathematics topics have been taught and to what extent? What are the reasons for the changes that have occurred? Often these changes depend on the opinions of the public and the respect they have for professions that rely heavily on mathematical knowledge. How

has mathematics been taught? Are today's methods very different from those used centuries ago?

The discussion about the links between History of Mathematics and Mathematics Education is gaining more and more force in the international field (Arboleda, 1983; Sierra, 1997; Anacona, 2003; Jankvist, 2007, 2009). Despite the different research projects, conferences and articles that have been developed around this topic in recent decades, there is still no complete clarity and consensus in the academic community about the contributions that history can offer to reflection on Mathematics Education, although the number of researchers and teachers interested in this connection is increasing.

Ways of approaching historical work are characterized, from each of which conceptual aspects are pointed out that point to and contribute to educational reflection on various forms of incidence of the History of Mathematics in Mathematics Education. For this purpose, two educational dimensions are fundamentally considered, one located in teacher training and the other linked to learning processes.

Interesting and essential is the survey (Clark et al., 2016, 2020) that describes the state-of-the-art, on *The role of the history of mathematics in mathematics education* developed at ICME 13, held in Hamburg in 2016. It gives a brief review of the developments since 2000,<sup>1</sup> on the relationships between the History and Pedagogy of Mathematics, in order to illuminate and provide information on the following general issues:

- Which story is appropriate, pertinent and relevant for Mathematics Education (ME)?
- What role can History of Mathematics (HM) play in ME?
- To what extent has HM been integrated into ME (curriculum, textbooks, educational aids/resource material, teacher training)?
- How can this role be assessed and evaluated and to what extent does it contribute to the teaching and learning of mathematics?

As a topic of reflection in the history of mathematics, two ways of approaching historical work on scientific knowledge have traditionally been distinguished: (a) the first considers that the object of the History of Science is science itself. This is how it is a matter of making a history of the concepts, basically attending to their logical structure of production; (b) the second, considers that explanations about scientific events can be obtained primarily from the social sphere, a position that is closer to a sociological aspect of science. However, there is a third path that tries to reconcile these two philosophical and methodological positions. It is possible to think of a work in the History of Mathematics that accounts for the complex processes of genesis, evolution and consolidation of a mathematical theory, without forgetting that these construction processes are developed within the framework of a sociocultural context, where they circulate particular pedagogical, philosophical and

---

<sup>1</sup>The year of publication of History in Mathematics Education: The ICMI Study, edited by J. Fauvel & J. van Maanen (2000).

theological conceptions, as well as educational policies, among others. Here we start from the premise that mathematics is, above all, a human activity; a complex social construction built over thousands of years in arduous processes of cultural interrelation. This means that mathematics is inescapably linked to its history; a story that accounts for its conceptual development, on the basis that such development takes place in the midst of complex social dynamics.

If the consideration that Mathematics Education is a field of an interdisciplinary nature can be accepted (Vasco 2002), educational problems must be thought of from each of the disciplines that make it up.

As an intervention of historical reflection in the training of mathematics teachers, there are many contributions that are of particular interest to teachers in their reflections on teaching. The study of the mathematical processes of construction, generally hidden in an exclusively formal presentation or in the school presentation, provides conceptual, methodological and epistemological elements that the teacher can use in their educational proposals:

- The history of mathematics as an element in the development of a curriculum.
- The history of Mathematics as an indicator of difficulties for understanding.
- The History of Mathematics in the design of educational activities.
- The History of Mathematics in the reflection on the nature of mathematics.
- The history of mathematics education
- And finally the intervention of historical reflection in the learning of mathematics:
- The history of Mathematics in the relationship between mathematics and experience.
- The History of Mathematics, source of problems and playful activities.
- Historical-epistemological studies as vehicles of knowledge.
- History as a bridge of communication between mathematics and culture.

Understanding and assuming cultural diversity is essential in the different educational instances, in an exercise of a new interpretation of the world. Understanding the relationships that are woven —between knowledge, behavior and culture— in the process of objectivation<sup>1</sup> of mathematical knowledge is important in this new reading of the world. In this sense, discussions are taking place in the international field from mathematics education in a sociocultural perspective. In this perspective, we must cite prestigious authors who have opted for the sociocultural line of mathematics education (D’Ambrosio, 1998, 2001; Radford, 2006, 2008), Skovsmose & Valero, 2007; Valero, 2006).

In a sociocultural perspective of education, knowledge ceases to be seen as an external product that must be appropriated by individuals, transgressing the paradigm of modernity, and is now understood as an interpretation that subjects make of the world, in a dialectic continuous with its social, cultural, historical and political environment.

That is, knowledge is produced from the subject in its interrelationships with the world. Under this sociocultural perspective, mathematics education assumes mathematical knowledge as a social activity, whose production and legitimation is the result of the explanation of different social practices in which the subjects are

involved, based on shared senses and meanings, respecting, thus, the different knowledge constituted by the various sociocultural groups within them.

Mathematics, in this sociocultural perspective, and as some authors point out, is seen as a product of human activity, which is formed during the development of solutions to problems created in the interactions that produce the human way of living socially, in a given time and context.

It is worth asking if there are other relationships between culture, curriculum and mathematics education, when it comes to teaching and learning mathematics. The discussion of these relationships can be made possible from some questions, namely:

- (a) What are the relationships between knowledge, behavior and culture in the objectivation (Jaramillo, 2011; Radford, 2006, 2008) of mathematical knowledge?
- (b) How are sociopolitical contexts in mathematics education understood?
- (c) How do some sociocultural factors that enable mathematical knowledge influence the teaching and learning processes of mathematics within the classroom?
- (d) What would happen if instead of looking at social practices from mathematics, we looked at mathematics from social practices?
- (e) What role does language play, as a constitutive element of the subject, in the production and objectification of mathematical knowledge?
- (f) How are the interactions that are woven between the teaching and learning processes, inside the classroom, mediated by the mathematical knowledge in question?
- (g) How to understand mathematical activity in the production and objectification of mathematical knowledge?

For its part, the work of Shkelzen (2017)<sup>2</sup> is a “portrait” of the debate between the main scholars of the multicultural approach and those of the intercultural approach, developed in the UK. After emphasizing the peculiarities and the critique of multiculturalism, around the recognition of diversities and the inclusion of foreigners, the comparison of said model with the current challenges facing the United Kingdom, marked by the dynamism and differentiation of ethnic minorities, leads to consider some of the intercultural theses as a better approach to representing and reacting to ethnic and religious diversities.

Multiculturalism is presented as a set of political doctrines, national and local intervention policies, initiatives by people from civil society, and a complex of public opinions put in the forefront in recent years in the European debate (Meer et al., 2016).

At the center of the multiculturalist theories there is citizenship, considered not only as a set of rights and duties which give a legal entitlement to have access to a passport, to vote, but also in a broader sense. The multiculturalists emphasize the

---

<sup>2</sup>Multiculturalism vs Interculturalism: New Paradigm? (Sociologic and Juridical Aspects of the Debate between the two Paradigms). *Journal of Education & Social Policy* Vol. 4, No. 2. p. 171–179.

importance of relations between the groups in an ethical context characterized by the respect for freedom and equality. Differently from the liberal theories, citizenship is conceived as relationship “in general”, not only as a specific relationship between individuals and the powers of the government.

In recent decades, the sociocultural and political discourses of mathematics education have been activated in different scenarios, particularly the approaches of the ethnomathematics research programs. This interest has been related to the need to recognize, value and legitimize other ways of doing and being, typical of the different cultures of a given country. Ethnomathematics as a possibility in the sociocultural perspective is a philosophical proposal that has been discussed since the 1980s by D’Ambrosio (1998, 2001) and Knijnik (1996, 1998, 2004), among others. In this work, they debate the production, validation and legitimation of mathematical knowledge within different social practices. Methodologically, this proposal could focus on alternatives such as project development and mathematical modeling, among others. However, it is notable to put the accent on the curricular proposal in mathematics with an approach from the underdeveloped ethnomathematics, as it happens, in different Ibero-American countries (Monteiro, 2005).

Understanding ethnomathematics (Stathopoulou & Appelbaum, 2019) as a methodology, we can affirm that, starting from a reality, it comes to pedagogical action in a natural way, through a cognitive approach with a strong cultural foundation (Monteiro, 2005). In this sense, the discussions and research in ethnomathematics show that this appreciation is not correct, since ethnomathematics is not a teaching methodology. I agree with some authors in affirming that ethnomathematics is set as a limit: the discussion of the knowledge of everyday life, already known by the students, undervaluing the knowledge acquired at the different levels of school education. On the other hand, mathematical knowledge can be recognized as a social production where the culture of the different communities and peoples plays an important role, from the social, historical, cognitive, political, epistemological and educational dimensions (D’Ambrosio, 2001).

Approaching mathematics education from a sociocultural perspective, when researching it and when preparing teaching activities, is not an easy task. There is always a certain tension in the conception of the term, between the ordinary professor and the researcher. This duality is the result of a neoliberal model in educational processes (Jaramillo, 2011), where attention must be paid, on the one hand, to the cultural diversity of the students, and, on the other, to the internal and external homogenizing processes of the institutions. Educational.

Insisting, in agreement with Jaramillo (2011), that undertaking mathematics education from a sociocultural perspective can lead us to move away from the theoretical concepts of knowledge with the training procedures provided by new technologies, in which the educational community and researcher remains submerged, not signifying the need to judge differently the concepts of science, knowledge and truth.

It is also important to point out that from ethnomathematics there is a positive position for the incorporation of social practices in curricular projects related to teachers and students.

Therefore, it must be understood that ethnomathematics appears as a possibility of putting mathematical knowledge at the service of everyday practices. This is how the teacher, in the context of the school, can structure “own knowledge” as a consequence of the social practices that are developed in the context of the community, together with the knowledge of the school. Consequently, ethnomathematics enables the production, ratification and legitimation of mathematical knowledge from social practices. The ways of acting, as well as the epistemological, gnoseological, axiological positions, etc. they have been determined by the interests of the researchers and by the communities with which the research is carried out. This is intended, in all countries, with greater or lesser acceptance, on the part of the educational community, to make visible the models of participation in the field of ethnomathematics and to show those possibilities, still to be implemented, the possibilities of paths still to be traverse or that it will be necessary to traverse again.

In the line of Clark et al. (2016) or Jankvist (2009), among others, the theoretical research carried out by Mathematics Education professionals on the incidences and effects that the use of the History of Mathematics can produce can be valued. in its refinement and quality.

On the other hand, the creativity that the use of the History of Mathematics can bring can be related to the theoretical advances made by teachers and researchers on the nature of mathematics itself in the school stage, especially in the constructivist stage, and which has led to a new paradigm in the developments of the binomial process Teaching/Learning of Mathematics: for example, the realistic mathematics of Hans Freudenthal (1973), represent a clear example of a philosophy of education, which contrasting the strategies carried out to teach mathematics, thinks that students must learn with real situations and that this knowledge can be useful in their lives.

If the management and use of the History of Mathematics is useful, it is convenient to quickly think about the principle of activity, advocated by Freudenthal: mathematics is a human activity and it is best learned by doing it. It makes no sense to learn the result of the math already done, you have to learn to do the math, the process of the activity itself. Problematic situations must be provided to students so that they acquire knowledge with which to face situations of daily life.

Familiarization with historical facts produced in certain civilizations, through examples based on the History of Mathematics, in Primary and Secondary Education, can offer students the possibility of working with a “type of mathematics” with which they could reach the objectives mentioned above ut-supra, mainly, In this way, you can get interesting material -exercises and problems- with which students can use outside class, for example those presented in Chap. 11 of this book: (a) ¿ Why did the Babylonians show interest in solving the quadratic equation? and (b) interesting is the treatment given to the resolution of the quadratic equation by Al-Khwarizmi”, giving rise to the appearance of the concepts “algebra” and “algorithm”. Regarding the design, implementation and evaluation of the tasks, we can mention that both teachers and students can benefit from the point of view of the use of the history of the history of the history of mathematics in the classroom.

It is also worth pointing out the historical categorization of the texts that can be used in Mathematics Education: (a) texts with resolution of problems addressed by

mathematicians in the period of conception, study and development of a mathematical concept; (b) texts with different descriptions in ancient and recent cultures; and (c) following Arcavi and Bruckheimer (2000), the use of texts used in the teaching of mathematics in students of school age.

Teacher training programs can serve to facilitate the revision of the generally negative affectivity with mathematics and with the teaching of mathematics, to support their active reconstruction of a positive and functional image of mathematics. These types of programs, such as those presented in Chap. 12 of this book (PST), employ a scientific stance and scientific inquiry practices to focus on mathematicians and their historical trajectories, in order to emphasize the scientific perspective. Systemic and interdisciplinary approach to mathematics, with the aim of empowering PSTs to rebuild their image of mathematics. Importantly, the history of mathematics is used as a means to acknowledge the seemingly paradoxical diversity and universality of mathematics, thus facilitating the development of inclusive pedagogical practices in their future careers.

The chapters present, in the context of the work carried out in the CIEAEM, the history of mathematics and its uses in mathematics education, identified and treated in the last hundred years. Perhaps, it should be said that in the last two it can be identified in the term of the use in the classroom of the history of mathematics in the training and education of mathematics teachers. It is shown that different international organizations, since then, pay much more attention to the use of the history of mathematics in mathematics education. For example, ICME (International Congress of Mathematics Education) with working groups on this subject. Also highlight the world association HPM (History and Pedagogy of Mathematics) that with regular meetings of its members act every 4 years in the context of ICME, with a satellite meeting. The history of mathematics and the history of mathematics education, although mainly related to mathematics itself, are marked by the national and international contexts of the societies from which they arise. We must also highlight the learning itself of our students in the classroom and the training of teachers. With different approaches of the authors it has been tried: (a) to understand and assume cultural diversity as indispensable in the different educational instances, in an exercise of a new interpretation of the world; (b) ethnomathematics as a possibility in the sociocultural perspective as a proposal of a philosophical nature; (c) the integration of the history of mathematics in mathematics education through the reflection of exercises carried out by primary and secondary school students; and d) teacher training with programs that can serve to facilitate the revision of the generally negative affectivity with mathematics and with the teaching of mathematics, to support their active reconstruction of a positive and functional image of mathematics.

Sixto Romero in this paper, we will try to contribute some ideas about the core of mathematics education in different times and cultures. One of the most widespread general trends today consists in the emphasis on the transmission of the thought processes typical of mathematics, rather than on the mere transfer of content. Mathematics is, above all, know-how, it is a science in which the method clearly predominates over the content. It is exposed as different institutions in many

countries have been working for decades to give a new approach to the teaching of mathematics, resorting to different ways of learning and working on the interaction between the history of mathematics in mathematics education using different points of view and in an eminently practical way (relationships between mathematics and other disciplines, technology in the Mathematics classroom, diversity and interculturality). It is interesting to propose how, when reexamining different approaches of the Teaching/Learning models, the role of the multicultural approach or orientation in the teaching and learning of our students in the subject of mathematics is weighed. Thus, to try to answer the question, why is a multicultural approach necessary in the teaching of mathematics? highlights that the multicultural nature of mathematics teaching is important because it humanizes the content of mathematics topics: people from all over the world have developed mathematical practices according to their needs and interests, specifically for practical, aesthetic and recreational purposes. It ends with a section of the chapter in which it makes a brief analysis of different approaches in various cultures that enriches both students and teachers, since they are better understood and valued, fostering critical thinking.

In Chap. 8, Peter Appelbaum and Charoula Stathopoulou present ethnomathematics (EM) as a challenge to inherited mathematical intuition, questioning different models of mathematical knowledge throughout history. This establishes a meeting point of interest between the history of mathematics, and the diversity of the sociocultural achievements of the human being, taking into account the flexibility of theoretical approaches whose body of formation is the classical theory that specializes in specific areas of interest. In the context of ME, the authors of this work highlight how it exerts its influence on the particular vision of the history of mathematics, placing it as a true discipline capable of identifying important social problems, as they point out in the introduction: colonization and problems related to gnoseology, epistemology, pedagogy,...in short, with training in education that allows assessing, as indicated, concerns related to equity and globalization. It also highlights how the history of MS leads to what they call ethnomathematics from a critical point of view. The theoretical structure presented in the work allows us to clearly visualize how ethnomathematics with a sociocultural approach, as indicated *ut-supra*, very prominent in the last century, has allowed placing mathematics education and mathematics in a preponderant place in society with its ideological fluctuations that lead to the reflection of teachers, professors and researchers on the conjunction that must exist between ethnomathematics, its history and the fusion of Mathematics Education and the History of Mathematics.

Sonia Kafoussi and Christina Margaritidou present some valid examples, from a fundamentally symbolic point of view, in activities that use the history of mathematics as a didactic resource in the process of the binomial Teaching/Learning. They carry out a prospective analysis of how the vision of the history of mathematics can influence EM, as an objective to be met and also raising the possibility of its use as a useful management tool. They experience and concretize it at various levels of primary and secondary education, with examples related to the resolution of equations and the use of allegorical exercises to symbology in ancient civilizations, such as the Egyptian and the Babylonian. The authors value the theoretical research



carried out by Mathematics Education professionals on the incidences and effects that the use of the History of Mathematics can produce in its improvement and quality. On the other hand, the creativity that the use of the History of Mathematics can bring can be related to the theoretical advances made by teachers and researchers on the very nature of mathematics in the school stage, especially in the constructivist stage, and which has led to a new paradigm in the developments of the binomial process Teaching/Learning of Mathematics. They also express that mathematics is a human activity and is best learned by doing it. Problematic situations must be provided that facilitate students to acquire knowledge with which to face difficulties and setbacks of daily life. In short, it can be said that the work presented by the authors describes very well, with various practical tasks, the use of history as a tool and history as an end. This type of mathematical learning can be a very positive tool to assess students' self-esteem towards understanding mathematical concepts through the use of the history of mathematics. In addition, they provide a very interesting reflection on the need to work on the history of mathematics as topics that are still open, and not sufficiently worked on both in the field of teacher training and work in the classroom.

Fragkiskos Kalavasis and Andreas Moutsios-Rentzos, in the work they present a teacher training program using the history of mathematics. They posit that the history of mathematics endows, pre-service pre-school and primary school teachers (PSTs) with an epistemological conviction of the need to elicit, express, and legitimize the diversity of their future students in their teaching practices, as a means of pragmatically addressing the need for inclusive mathematics pedagogy. It is interesting the argument that they expose affirming that the universality and the effectiveness of mathematics can emerge from the documented and lived consideration of the diversity of the manifestations of mathematics, which can be internalized and inscribed in the culture, practices and mathematical identity. School. For its part, supporting the PST leads to an approach to education that allows one to experience mathematical creation as lived by famous mathematicians who acted and interacted in complex scientific, sociocultural and political scenarios, which allowed them to build an image of mathematics, diverse, full of advances and setbacks, of reorganizations, far from being absolute, in short, a construction, of an anthropological nature, intertwined with other disciplines, but clearly different from them. Considering the contributions of other authors, they insist that future teachers should be given a new responsibility that may arise from reading historical texts that influence support and encouragement to value joint participation. With this, for the authors of the work it means that such findings are particularly encouraging and relevant to the assumption that the history of mathematics can be an important tool to design an inclusive mathematics education: to use the history of mathematics as a means to facilitate the reconstruction of the cognitive and affective relationship of pre-service pre-school and primary school teachers (PSTs) with mathematics through a systemic and interdisciplinary approach.

Finally, a retrospective look at the history of the CIEAEM<sup>3</sup> from its beginnings in August 1950 in Debden (United Kingdom) to the present, at the last face-to-face meeting held in Braga (Portugal) in 2019, allows us to affirm that we must be self-critical. It has been almost 70 years since its creation and the topic at hand, *The Role of the History of Mathematics in the Teaching /Learning Process: A CIEAEM Sourcebook*, has been dealt with very few times. Although it is true that in the meetings of Quebec (1973), Lisbon (1983), Berlin (1995), Chichester (1999), Vilanova i Geltrú (2002), Palermo (2005), Sni (2006), Rhodes (2012), Berlin (2017), Mostaganem (2018), we can affirm that the theme has not been treated in depth, only as such, it should be highlighted as an ad-hoc theme in Berlin (1995 and 2017), Palermo, Sni, but above all Chichester (1999) with the central theme of the meeting, *Cultural diversity and mathematics education*.

Perhaps it is necessary to include permanently, and here is my proposal, that in the next events of the Commission a section dedicated ad-hoc be dedicated to dealing with the generic theme that gives the title to the book *The Role of the History of Mathematics in the Teaching/Learning Process*. It would be a way for the CIEAEM to contribute to the empowerment, dissemination and development of the history of mathematics in mathematics education in a constructive dialogue from different perspectives in which ethnomathematics should play an important role, which can and should produce a great advance. That allows us to work collaboratively, making the theme of the CIEAEM-70 held in 2018 in Mostaganem (Algeria), “Mathematics and living together”: Why, How, What? So be it!

## References

- Anaconda, M. (2003). La historia de las matemáticas en la educación matemática. *Revista EMA*, 8(1), 30–46.
- Arboleda, L. C. (1983). Historia y enseñanza de las matemáticas. (N° 4, *Serie Epistemología, Historia y Didáctica de la Matemática*). Universidad Nacional de Colombia.
- Arcavi, A., & Bruckheimer, M. (2000). Didactical uses of primary sources from the history of mathematics. *Themes in Education*, 1, 55–74.
- Chartier, R. (1987). *The cultural uses of print in early modern France*. Princeton.
- Clark, K., Kjeldsen, T. H., Schorcht, S., Tzanakis, C., & Wang, X. (2016). *History of mathematics in mathematics education: Recent developments* (pp. 1–42). [https://www.academia.edu/26341958/History\\_of\\_Mathematics\\_in\\_Mathematics\\_Education:\\_Recent\\_developments](https://www.academia.edu/26341958/History_of_Mathematics_in_Mathematics_Education:_Recent_developments)
- Clark, K. et al. (2020). *History of mathematics in mathematics education: Recent developments*. <https://hal.archives-ouvertes.fr/hal-01349230/document>

<sup>3</sup><https://www.cieaem.org/index.php/en/>; <https://www.cieaem.org/index.php/en/meetings-en/previous-meetings>;

- D'Ambrosio, U. (1998). *Etnomatemática*, 4.a ed., São Paulo, Ática.
- D'Ambrosio, U. (2001). *Etnomatemática: Elo entre las tradiciones e a modernidad*. Belo Horizonte.
- De Guzmán, M. (2001). *Tendencias actuales de la educación matemática*.
- Freudenthal, H. (1973). *Mathematics as an educational task*. Reidel.  
<http://www.mdeguzman.net>  
<https://www.encyclopedia.com/history/encyclopedias-almanacs-transcripts-and-maps/dissemination-knowledge>
- Jankvist, U. T. (2007). Empirical research in the field of using history in mathematics education: Review of empirical studies in HPM2004 & ESU4.
- Jankvist, U. T. (2009). *Using history as a "goal" in mathematics education*. Dissertation. Department of Science, Systems and Models, IMFUFA, Roskilde University.
- Jaramillo, D. (2011). La educación matemática en una perspectiva sociocultural: tensiones, utopías, futuros posibles. *Revista Educación y Pedagogía*, vol. 23, núm. 59.
- Kjeldsen, T. H. (2011). Uses of history in mathematics education: Development of learning strategies and historical awareness. In M. Pytlet, T. Rowland, & E. Swoboda (Eds.), *Proc. of CERME 7*. University of Rzeszow.
- Knijnik, G. (1996). *Exclusão e resistência – Educação Matemática e Legitimacao Cultural*. Artes Médicas.
- Knijnik, G. (1998). Educação Matemática e os problemas da 'vida real. En: À. Chassot y R. J. d. Oliveira (Eds.), *Ciência, ética e cultura na educação, São Leopoldo*, UNISINOS.
- Knijnik, G. (2004). Etnomatemática e educação no movimento 'Sem Terra'. En: G. Knijnik, F. Wanderer y C. Oliverira (Eds.), *Etnomatemática: currículo e formação de professores* (pp. 53–69). EDUNISC.
- Meer, N., Modood, T., & Zappata-Barrero, R. (2016). *Interculturalism and Mul-ticultural-ism, Edimburgh*. University Press.
- Monteiro, A. (2005). Currículo de Matemáticas: reflexões numa perspectiva enomatemática, 7. *Encuentro de Educación Matemática*, Asocolme, Tunja.
- Radford, L. (2006). Elementos de una teoría cultural de la objetivación. *Revista Latinoamericana de Investigación en Matemática Educativa* (Special Issue on Semiotics, Culture and Mathematical Thinking).
- Radford, L. (2008). The ethics of being and knowing: Towards a cultural theory of learning. In L. Radford, G. Schubring, & F. Seeger (Eds.), *Semiotics in mathematics education: Epistemology, history, classroom, and culture*. Sense Publishers.
- Ramírez, A. V. (2009). La teoría del conocimiento en investigación científica: una visión actual (Knowledge's theory in scientific research: a current scope). American College of Occupational and Environmental Medicine. *Anales de la Facultad de Medicina*, 70(3), 217–242.
- Romero, S. (2020) Algunas reflexiones sobre la divulgación del conocimiento científico. *Encuentro entre Academias Americanistas Andaluzas. Instituto de Academias de Andalucía. Consejería de Economía, Conocimiento, Empresas y Universidad* (pp. 41–43). Junta de Andalucía. Málaga (España).

- Shkelzen, H. (2017). Multiculturalism vs interculturalism: New paradigm? (sociological and juridical aspects of the debate between the two paradigms). *Journal of Education & Social Policy*, 4(2), 171–179.
- Sierra, M. (1997). Notas de Historia de las Matemáticas para el currículo de secundaria. En L. Rico (Coord.), E. Castro, E. Castro, M. Coriat, A. Marín, L. Puig, M. Sierra y M. Socas (Eds.), *La educación matemática en la enseñanza secundaria* (pp. 179–194). ICE-Horsori.
- Siu, M.-K., & Tzanakis, C. (Eds.). (2004). The role of the history of mathematics in mathematics education. *Med JRME*, 3(1–2), 1–166.
- Skovsmose, O., & Valero, P. (2007). Educación matemática y justicia social: hacerle frente a las paradojas de la sociedad de la información. En: J. Jiménez, J. Díez-Palomar y M. Civil (Eds.), *Educación matemática y exclusión*, Barcelona. Ed. Grao.
- Stathopoulou, C., & Appelbaum, P. (2019). Mathematics education and Ethnomathematics – Living together with each other. *Quaderni di Ricerca in Didattica (mathematics)*. G.R.I.M. (Departimento di Matematica e Informatica) (pp. 49–61). University of Palermo.
- Valero, P. (2006). *Consideraciones sobre el contexto y la educación matemática para la democracia*. Foro Educativo Nacional. Año de Competencias Matemáticas.
- Van Loon, M., & Sarzano, M. (2016). *Quelques problèmes de la conception duale de la norme de l'action et de l'assertion*. Ed. La Connaissance et ses raisons. Chevalier, J.M, Gaultier, B. La Philosophie de la connaissance au Collège de France.
- Vasco, C. (2002). Siete tensiones irresolubles en la articulación de la historia de las matemáticas con la enseñanza de las matemáticas. *Conferencia inaugural de la Primera Escuela Latinoamericana de Historia y Epistemología de las Matemáticas*. Universidad del Valle.

# Chapter 5

## Mathematics Education in Different Times and Cultures



Sixto Romero Sánchez

**Abstract** In this work we will present some references on the trends of mathematics education throughout its process of adaptation to the new times that must look at their reflection in the mirror of the cultures they represent, always considering their vertiginous changes. A multicultural and intercultural approach in the classroom thanks to the study of some cases that occurred in developing countries will make us understand certain ways of objectifying mathematical knowledge based on a dialogue between social and school practices. Counting on the idea that all peoples have developed a mathematical thought in relation to their vital context, geography, history, cosmogony and their mythical stories, both theoretical and practical knowledge can be used to solve their daily problems.

Thus, certain skills which are studied, they also include symbolic systems, spatial designs, techniques, construction practices, calculation methods, models and measurements of time and space, specific forms of reasoning, and other problems and activities, all of them developed in different towns, such as case studies in developing countries: the use of social and school practices within an indigenous school, Afro-Colombian studies and basic standards in competencies with intercultural dialogue and some mathematical competencies in the project Chair of Afro-Colombian Studies (CEA).

**Keywords** Multicultural · Intercultural · Practical knowledge · Mathematized society · Dynamic process

### Introduction

Competencies to evaluate mathematical applications and their potential usefulness are now a fundamental precondition for planning within political administrations and democratic citizen participation. The new challenge is to determine what kind of

---

S. R. Sánchez (✉)  
University of Huelva, Huelva, Spain  
e-mail: [sixto@uhu.es](mailto:sixto@uhu.es); <http://sixtoromero.com/>

knowledge about social knowledge is needed in a mathematized society and how its components can be acquired. Different institutions in many countries have been working, for decades, to give a new approach to the teaching of mathematics by using several forms of learning and working on the interaction between the history of mathematics within mathematics education from different points of view and in multiple, eminently practical ways, (relationships between mathematics and other disciplines, technology in the mathematics classroom, diversity and interculturality. . .) (MEC, 2006).

Max Scheler (1874–1928), a German philosopher of great importance in ethics and philosophical anthropology, as well as the development of phenomenology, used it to study emotional phenomena and their respective internationalities (values) with which he developed a very solid, original personalist foundation of ethics: the realization of values was concretized in human models that invited to their follow-up. Scheler distinguished three types of knowledge: inductive, essential - also named ‘phenomenological structure’- and metaphysical (Scheler, 1934).

When this classification is applied to mathematics we can say that the knowledge of the Egyptians was practical: they were interested in the solution to concrete problems which were generated by social organizations such as architectural constructions, taxes, commercial transactions, establishment of limits in crop fields next to each flood of the river Nile, etc. . . . It was a useful knowledge to modify and improve the world for it to be ‘organized’ and inhabited. Later, Greek era started. Greeks were a typical example of cultured people in all aspects of knowledge, especially in mathematics, who studied in order to understand nature and universe, apart from capturing its harmony, reasoning activity, etc. Some of the most representative people regarding this era of mathematics were par excellence Apollonius of Perga (2nd century B.C.), author of books on conics, Eratosthenes of Cyrene (2nd century B.C.) who ingeniously knew how to measure the radius of the Earth from the distance existing between Alexandria and Siena and their latitudes, and finally Claudius Ptolemy (2nd century B.C.) author of the *Almagest*, a work that systematized all the knowledge about astronomy by that time.

Along with other authors, usually compilers of earlier works, people like Pappus (3rd century), Diophante (3rd century) or Proclus (5th century) need to be mentioned here. This way we will go back to the Middle Age, when most part of the Western world began to worry about the knowledge of salvation whose essential interest was to participate in the existence and constitution of things (Santaló, 1994).

Since the Romans, contents of the trivium – grammar, history and dialectics, also named ‘the art of word’ – were the knowledge that was the object of formal teaching; and contents of the quadrivium – arithmetic, geometry, astronomy and music, also named ‘the art of thought’- were institutionalized by Plato in his work *The Republic*. This knowledge did not have its own purpose, for which a limited use was not needed in order to increase the knowledge already acquired or to promote sciences by themselves, but it was enough to make an inventory of the inheritance of the past in encyclopedias, more or less extensive (Bréhier, 1926). This led to the fact that no original mathematics was produced. Whereas sciences related to ‘the divine’ were highly developed, other sciences -and especially mathematics- were reduced to the

reproduction of the classical works of the Greeks which was often misrepresented and poorly understood. These works were *Etymologies of San Isidoro* (570–636, bishop of Seville, Spain) and *On the Nature of Things* by Bede the Venerable (672–735). They were very famous as they pretended to contain all the knowledge of that time. But they did not contain any important mathematical novelties despite of being very extended texts for many centuries. Precisely, this respect and cult of exaggeration for notable predecessors were the reasons for which mathematics education was reduced to a continuous repetition of the classical works. Mathematics went into decline due to the lack of creative vitality, returning back even to the level of previous centuries. And it is for centuries when the difference between mathematics for researchers -or trained mathematicians- and mathematics for users and the proportion of both trends in elementary education has caused a great controversy and discrepancies amongst mathematicians, as well as amongst psychologists and educators.

In the eighteenth century the efficacy of Euclid's *Elements* in the learning of geometry began to be questioned when Alexis Claude Clairaut (1713–1765) said in a geometry text for high school: '*... although geometry itself is abstract, it must nevertheless be admitted that the difficulties experienced by those beginning to apply it stem most often from the way it is taught. ... It always begins with a large number of preliminary definitions, demands, axioms and principles, which seem to promise nothing but antipathy to the reader. ...*' (Clairaut, 1741).

## **What Kind of Knowledge Is Necessary in a Mathematized Society?**

Taking a leap in time, mathematics is currently considered the most powerful social media for planning, optimizing, directing, representing and communicating man-made social issues. Thanks to the development of modern information and communication technologies based on mathematics, this social impact has reached its highest splendour: mathematics is now universally used in all fields of society and there is hardly a political decision-making process in which mathematics is not used as the rational argument and objective basis for political judgments and power relations to be replaced. However, it becomes increasingly tedious and sometimes even impossible for the ordinary citizen to follow these developments in mathematics as well as in mathematical applications, and to evaluate their social use in an appropriate way, since specialization and segmentation of mathematical applications are often extremely difficult to understand. The main perception of its purpose and the basic knowledge of its general importance are frequently confronted with a complete lack of knowledge of concrete examples of its impact. But competencies to assess mathematical applications, and so their potential utility or their problematic effects, are now a necessary precondition for political executive and democratic citizen participation.

### ***Some Historical Considerations of Mathematics in Relation to the New Social Visions of the World***

In 2004, in Huelva (Spain), when Cristine Keitel presented her work about historical considerations of mathematics in relation to new social visions of the world *The teaching of mathematics in the knowledge society or how much mathematics does a prime minister need?* she highlighted:

- (a) Mathematics as a distinctive tool for solving problems in social practices and as means of social power.
- (b) Mathematics as a theoretical system and universal cosmic vision with a new perspective.
- (c) Mathematics as a human effort and driving force for scientific and social development in general.
- (d) Mathematics as rationality and common sense where it played a decisive role: in the thirteenth century universities created the interest for the Renaissance movement in ancient culture, and the printing press made them be available for a larger audience and the media development revolution.
- (e) The knowledge of non-European cultures.
- (f) The growing social needs for teaching mathematics led to mathematics education as a public task.

When Wilhelm von Humboldt established the state educational system in Prussia at the beginning of the nineteenth century, he created the idea of the *Bildung*—word generally translated as ‘training’ in English and Spanish, which do not totally capture its meaning. *Bildung* encompasses learning as universal as possible with a great emphasis on humanities such as philosophy, history, literature, art, music. . . but also on mathematics and science (Keitel, 2004).

### ***Combination of Education and Knowledge Needed to Prosper in Today’s Society***

There are many definitions of *Bildung*. The European Bildung Network describes it like ‘the combination of education and knowledge needed to prosper in our society, and the moral and emotional maturity for team working while having personal autonomy at the same time’ (Cofunded by Erasmus, 2021).

The reason for which it is called the ‘Bildung Rose’ (Andersen, 2019, 2020) and not ‘the Society Rose’ is because we need to understand the following domains of our society for us to prosper (Fig. 5.1).

Mathematics has become a subject in higher education because of its formal educational qualities like educating the mind to be independent from a direct utilitarian perspective, and also because it promotes general attitudes of support for science-driven scientific and technological development.



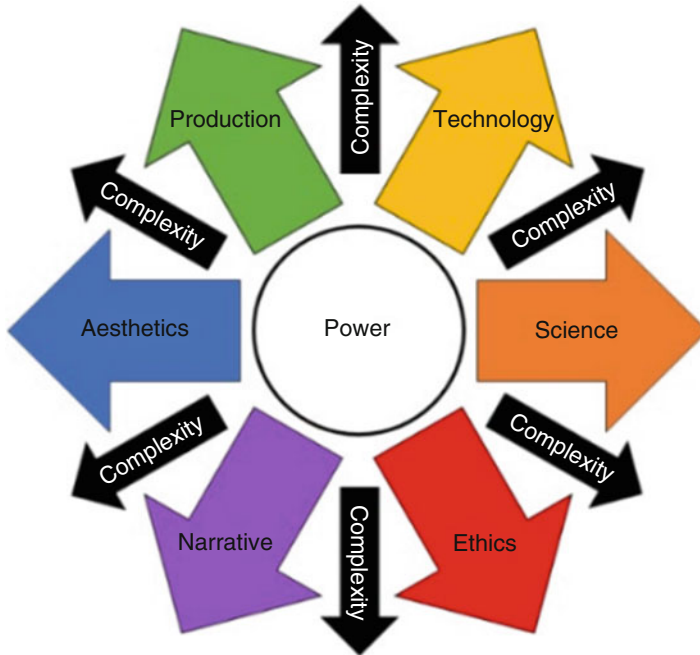


Fig. 5.1 Bildung Rose. (<https://nordicbildung.org/papers/the-bildung-rose/>)

In the 19th and 20th centuries, mathematics became the main driving force of almost all scientific and technological developments: mathematical and scientific models and their transformation into technology had their impact not only on the natural and social sciences and on economics, but also on all activities of social, professional and daily life. This impact was rapidly increased by the development of new information and communication technologies based on mathematics, which radically changed the social organization of work and our perceptions about knowledge or techniques to a point not fully explored yet.

It can become part of the learning experience in different ways when the concept of ethnomathematics (mathematical ideas from different cultural groups) are included in the curricular texts. From here, incorporated into the mathematics texts in the Western class, these are transformed with the following variations of form and achievement of objectives (Dickenson-Jones, 2008). The research carried out by this author provides a conceptual model that illustrates different modes of transformation that can occur when indigenous cultural practices are incorporated into the texts of the mathematics curriculum. To illustrate aspects of the model, the cited work: (a) includes an example of the Australian Aboriginal practice of throwing a return boomerang. With this, she gets the main actors (students and teachers), from constructive criticism working in the classroom, to reflect on the ways in which ethnomathematical ideas are modified when they are used in class; (b) the cultural praxis is also altered, allowing the teacher to elaborate and build their own curricular

texts that contain the different models of transformation. In short, the aim of the model developed in this research is not to criticize the potential educational value of ethnomathematical ideas in curriculum. Rather, the model provides a tool that may allow teachers of mathematics to identify the different kinds of representations of indigenous cultural practices in ethnomathematical curriculum and to choose those that are the most suitable for their own classroom environment.

On the one hand, mathematics being taken as a human activity in a social environment is determined by social structures, hence it is not disinterested or politically neutral. As opposed to it, the continuous application of mathematical models, being considered as universal problem-solving procedures, provides not only descriptions and predictions of social actions, but also prescriptions. Social and political decisions are translated into facts, restrictions or prescriptions that individuals or collective human behaviour must follow. Then how can we deal with these demands? What will keep the necessary knowledge, as this must be provided and the appropriate form of education must be offered, if mathematics plays such an important role in society and if the individual is supposed to act, knowingly, in accordance with the individual and social interests?

Since the end of the twentieth century, new perspectives on the social role of knowledge of mathematics and general education have been developed and have gained acceptance and political support: the ‘Knowledge Society’ and the ‘Teaching of mathematics for all’.

In the last 60 years there have been many profound changes in the teaching of mathematics. Due to the efforts that the international community of experts in mathematics education is still making with the aim of finding suitable models, it is evident that we are witnessing a situation of experimentation and continuous change (Romero, 2016, 2019). Back in the 1960s and 1970s, the renovating movement towards modern mathematics already brought with it an important transformation of teaching, both in its nature and in its new content (De Guzmán, 2001), where some details are provided in Sect. 3.2. from the section developed in the section of this article indicated ut-infra, *Brief reflection on trends to face challenges in mathematics education*.

One of the most widespread general trends today, related to mathematics education in different times and cultures at least, is about the emphasis on the transmission of the thought processes of mathematics rather than on the mere transfer of the content (Keitel, 2006). Mathematics is, above all, a know-how science as the method clearly predominates over the content.

It is necessary for T/L model to be adapted to new times in different cultures for new approaches to be restructured. A brief reflection on the current problems of mathematics education will lead us to face challenges (Karp, 2016) by overcoming particular ad-hoc situations, which had already appeared thousands of years ago, but when they were approached from a generalist or universal point of view, different forms of approaches appeared in solving problems associated with the endemic characteristics of each area.

It is important to add that when different approaches are being re-examined to E/A, we need to weigh the role of multicultural orientation on mathematics itself at the time of teaching and learning by our students.

Regarding the question about why a multicultural orientation is needed we find an interesting answer in the works *Teaching Mathematics Concepts Using a Multicultural Approach* (Uy, 2000) and *Multicultural Math Classroom* (Zaslavsky, 1996). Also, a multicultural approach to science is generally important -and particularly to the teaching of mathematics- because it produces the necessary humanization of science. In my most sincere opinion, the scientificity of humanities, situated far from ordinary citizens, should be more humane and familiar, as well as much closer and friendly. This would mean humanizing the mathematical lessons and their content. People around the world have developed mathematical practices according to their needs and interests, especially for practical, aesthetic, and recreational ones.

The book *Teaching with a Multicultural Perspective: A Practical Guide, 2nd Edition* (Davidman & Davidman, 1994) provides a clear model with objectives leading to the creation of effective instructions in culturally diverse settings. For its part, ethnomathematics reflects on the role of this multicultural perspective in different environments. You can, for a better understanding, read the Chap. 8 of this same book (Appelbaum & Stathopoulou, 2022), *History of Ethnomathematics: Recent developments*,

Based on a set of field-tested planning questions and linked to some curricular case studies, as well as educator profiles and activities, it makes a series of clear and compelling connections between multicultural theory and practice. Some authors think that mathematics does not seem to be a promising subject for multicultural education because mathematical truths are universally valid. However, all cultures produce mathematical ideas, just as they produce different languages and social systems too. Besides, it must be recognized the history of mathematics as well as the social and political values that have shaped the development of mathematics curricula (Nelson, 1993). For this, an analysis of the different approaches is essential to enrich a multicultural approach for both students and teachers, since they understand each other and value themselves much better by promoting critical thinking because the multicultural teaching of mathematics provokes in students a stimulus of depth and expansion of knowledge: thinking, learning and applying concepts is done from multiple perspectives.

## **Brief Reflection on Trends to Face Challenges in Mathematics Education**

In relation to the knowledge of our society, it seems reasonable that the educational system participates in its generation and promotion, as well as its democratization forces the principles of merit and effort to be a reference in these environments. And as a result, the State is the backbone of the national system by defining the contents

of teaching thanks to the core subjects. As indicated by the OECD, ‘...*qualifying the system through external evaluations at the end of the cycles and reinforcing its presence in the autonomous sphere through high inspection has not been exercised and has generated educational lack of control. . . The reality, however, has actually been distorting the teaching and its results. . .*’ (Luengo, 2018).

### ***Education as a Dynamic Process***

Education has a truly, fascinating aspect: it is an active, dynamic process, in constant construction, and undoubtedly highly contextualized. This characteristic makes changes and contributions to be introduced in order to ensure its permanent renewal.

From this point of view, research reappears as an inherent activity in the educational process; despite the scientific research is more or less rigorous, it must always be oriented to find answers for real needs and problems which are faced by everybody in a certain field of science.

Then an important reflection comes up in the field of research: which lines or fields of knowledge should we orient our research efforts to? Areas related to technology and experimental sciences have traditionally enjoyed the privilege of greater attention in this aspect, unlike what has happened in the field of humanistic sciences and education.

Nowadays, we find a reality which is sufficiently verified in studies and research, as an evidence of the enormous educational deficiencies of our population: graduates of basic, intermediate and higher level struggling to write a letter, to make themselves understood, to express an idea, to make estimates, to propose reasoning or problem solving, analysis or synthesis of particular situations. . . We definitely see here intellectual limitations that lead us to ask ourselves: where is the origin of these problems? Technology? Or maybe our human, social and educational reality?

It is about something beyond the investigation of deep, rugged problems, or the study of simple situations and daily practices, which are common aspects to our educational work and our sociocultural reality. This is an important source of research, even more than a science with a high value of social intersubjectivity such as mathematics and mathematics education in general.

Researching in the field of mathematics education has been favoured by the rise of ‘research in education’; it has established itself as a field of study which has progressively evolved in order to be positioned from a philosophical perspective, much more than from a scientific one reaching ‘the necessary experience’ to have an identity of its own. The growing concern for mathematicians and educators about what kind of mathematics is taught in school, how this subject is learned and what and how it should be taught, has represented the main stimulus for the configuration and delimitation of the problems about this field of study and the adequate methods for its knowledge and intervention (Castro, 2007).

There is a world-wide community of educators, researchers, departments, institutions, etc., which is concerned about study and research in this field. They have

also contributed powerfully to the constitution of ‘the new discipline scientist that deals with problems related to Mathematics Education’ (de Guzmán, 1996; Godino, 2004). Efforts to strengthen academic cooperation and the linkage amongst different working groups have found some bases in the actions of groups and institutions such as the International Commission on Mathematical Instruction, the National Science Foundation (NSF), the UNESCO, the International Congress of Mathematics Education (ICME), the Inter-American Committee on Mathematics Education (CIAEM), the Commission Internationale pour l’ Étude et l’Amélioration de l’Enseignement des Mathématiques (CIEAEM), or the Commission for the Study and Improvement of Mathematics Teaching or the Latin American Meeting of Educational Mathematics (RELME).

### ***Current Trends in Mathematical Education***

Miguel de Guzmán, a Spanish professor and president of the International Commission on Mathematical Instruction (ICMI), made at the end of the 90 s an interesting reflection on some aspects of the panorama of mathematics education in an excellent article entitled *Current trends in mathematical education*:

- Why is teaching mathematics a difficult task?
- Why is it necessary to study the change in the Didactics of Mathematics within each period?
- General trends in mathematics education
- Changes in methodological principles
- Some current trends in the contents

Amongst all the aspects that have been extracted from his approach and recommendations, it must be highlighted the initial and permanent training of mathematics teachers, research in mathematics education, mathematics education of society, popularization of mathematics and attention to early talent in mathematics.

Below I will present a summary scheme of this contribution by providing some ideas that complement the work referred to.

Mathematics is a way of approach to reality. It provides important elements for the development of the capacity for rational argumentation, reflective abstraction and the increase of the skills which are needed to solve problems not only in the school environment, but also widely applied and transferred to other fields of knowledge. These aspects constitute valid arguments for the mathematical education and, consequently, for the promotion and stimulation of research initiatives in this field, both of studies about pure research (epistemology and structure of science) and of those which are closest to teaching practice (planning, teaching strategies, development and use of resources and evaluation) that could be classified as applied research. Research in the field of mathematics education represents an alternative that could contribute not only to the development and stimulation of investigative skills of those people who assume it, but would also broaden the horizons of the

didactic-pedagogical analysis criteria, which favour the prospective, strategic and tactical vision of this science that are needed for all professionals, and especially for those in the educational field (Castro, 2007).

In order to delve into this question, I would like to add some comments about the thought of pedagogical renewal. This concept, which promotes a deepening of active and emancipatory practices in education if it is taken as a tendency, has experienced some historical moments of different intensity and in many ways all over the world. Its trace throughout history has penetrated into the world of education and pedagogy up to our days. It needs to be mentioned that the case of Spain -with a background of important history in Europe and in the rest of the world- is not a preferential study aim in this work, as in different regions the required renovation has not been carried out in the same way. From a critical perspective, it must be reviewed what the concept of contemporary pedagogical renewal has meant, and what it has also meant for Spanish education since many times its footprint has been diluted within the recent history of the country.

The fact of valuing the action of the Pedagogical Renewal Movements of that time can provide us with crucial clues and reflections on the situation of education at the procedural moment and today too, since many elements of its problem keep persisting and have not been addressed with sufficient details and depth although exponential progress has been made. Far from posing here a nostalgic anecdote of what the pedagogical renewal of the last decades meant -and still means- we must weigh up the results obtained as indicated *ut-supra* (Lorenzo, 2016).

, shows us that some of the changes which had been introduced in the 70 s turned out to be not successful like, for instance, when elementary mathematics lost content as geometry and it was replaced by algebra. Besides, drawbacks that arose with the introduction of modern mathematics far outweighed the questionable advantages that had been thought to achieve, for example, the rigor in the foundation and the understanding of mathematical structures.

The integration of historical and epistemological questions in the teaching and learning of mathematics constitutes a possible natural way of discovering, a better understanding of the specific parts of mathematics, and also a greater awareness of what part of mathematics is part of knowledge. This is something that practically everyone has an idea of (Santaló, 1994).

In mathematics education, mathematics is the result of contributions that have been taken from many different cultures, as well as its constant dialogue with other scientific disciplines, philosophy, arts and technology and being constantly updated with changes throughout history. These all facts are a constant force of encouragement and scientific, technical support, and so artistic and social development (Clark et al., 2016). As mathematics is fundamental to modern society, these facts will improve mathematics education since the historical and epistemological questions of mathematics are equally important because when its harmony is mixed with other areas of knowledge, they make a greater connection between humanities and sciences.

## *New Challenges in the Teaching of Mathematics*

New challenges related to the teaching of mathematics that the international community had to face were passionately carried out (De Guzmán, 2001) on the benefits and deficits of the trends that were making their own way over time. As significant changes are taking place more and more in mathematics education, in the most developed countries there has been a growing interest of a large number of mathematicians who have focused in the problems currently posed at different levels, from the primary education to university.

The work of Gravemeijer (1994) that can be contemplated in the Education and Social Environment project (OSM), which finally appeared in the publication of the textbook series *Rekenen en Wiskunde*, sets the tone for the elaboration of a plan of mathematics studies that embodies the main characteristics of realistic mathematics education with the aim of changing educational practice in schools.

Besides, NCTM (2000) asserted that educational technology (computers) could help to teach content as it could offer students a linkage from concrete to abstract thinking by enabling them to observe and create multiple representations of mathematical ideas.

Also, HAL needs to be mentioned, a multidisciplinary open access that can be used for the deposit and dissemination of scientific material, research documents, whether published or not, which may come from teaching and research institutions of public or private research centers. Since 2000 it indicates the topics of TSG 25 (ICME 13) (Clark et al., 2016) in which the state of the art on the relationships between history and mathematics pedagogy is described in order to enlighten and provide insight into the following general questions:

- Which history is suitable, pertinent, and relevant to Mathematics Education (ME)?
- Which role can History of Mathematics (HM) play in ME?
- What extent has HM been integrated to in ME (curricula, textbooks, educational aids/resource material, teacher education)?
- How can this role be evaluated and assessed and what extent does it contribute to the teaching and learning of mathematics?

Highly-prestigious mathematicians have advocated as a priority the advancement in mathematics education from different topics mentioned above:

- *Mathematics Education and Language Diversity* (Barwell et al., 2016). Here the authors introduce challenges and possibilities for the development of indigenous mathematics education in multilingual contexts, as well as recent movements towards the recognition of linguistic and cultural diversity and opening spaces for new debates on education that must be recovered, and a cultural identity to be reclaimed.
- *Why including the History of Mathematics in Mathematics Education* (Clark et al., 2016; Palenzuela, 2017; Tzanakis et al., 2002; Arcavi, 1991; Ernest, 1998; Furinghetti & Somaglia, 1997; de Guzmán, 1993).

- The cultural, humanistic, interdisciplinary character and the possibility of its curricular organization are shown with the hope for the concern and need for the use of the history of mathematics as a didactic resource in the classroom to be sparked (Arcavi, 1991; Fauvel, 1991).
- The proper use of the history of mathematics helps to teach the subject. But in these times of mathematics for all, the history of mathematics is the most important thing, like an integral part of the subject TO HAVE A WIDER perspective OF IT and to present a more complete picture of what mathematics is FOR the public community (Siu & Siu, 1979; Siu, 1997).
- Studying the history of mathematics rather than just using it as a tool, and this means trying to understand it as a historian does. Then we can realize that mathematics is something that humans do and therefore it helps us to understand human identity itself. This way the history of mathematics in mathematics education has potentially made us fuller human beings, which is known in the heart of the educational tradition as ‘liberal arts’ (arts of a free human being). By considering the nature of liberal arts we can better understand the significance of the history of mathematics in mathematics education (Fried, 2018).
- The twenty-first century faces enormous challenges that increasingly and universally come from interrelated societies. Thus, it is possible to observe significant economic changes in the globalization of capitals and markets, both industrial and financial; or extremely dynamic advances in science and technology, in mechanical, virtual and spatial spheres, etc. All of this has affected all living beings that are part of this reality. Our cultures have absorbed all these new globalized aspects, by making them their own and interchangeable: communications are almost instantaneous in real time; the mobility of information is surprising; war conflicts between countries being broadcast on television; literacy is linked to the computer; virtual reality is almost the new company of children, much closer than manual, collective creation games. We are undoubtedly immersed in a scientific-technical revolution that means a new way of producing and thinking about what we are surrounded by. The theoretical-practical needs and problems have demanded epistemological changes and ruptures, and even rationality. According to what it was suggested by Thomas Kuhn, an American physicist, philosopher of science and historian who is known for his contribution to the change of orientation of philosophy and scientific sociology in the 1960s, we can say that we are facing paradigm changes as a result of scientific revolutions. At the end of the twentieth century these partial, disciplinary scientific movements began not only to be interrelated, but also to be measured as a single movement. In this sense, some authors began to identify and deepen the reflections on synchronic similarities, despite the different plots and knowledge problems. And all of this has turned out to be the configuration and denomination of a new generalizing scientific paradigm, which is capable of encompassing all sciences in general -and mathematics in particular- as it is the emergence of this new complex or complex paradigm. The scientific paradigm of complexity (Romero, 2020) comes up to overcome the historical insufficiency, like the classical paradigm and its





**Fig. 5.2** Complexity Theory. (*Quaderni di Ricerca in Didattica (Mathematics)*, Numero Speciale N°. 7, 127–138. Università di Palermo)

corresponding assessment of the notion of simplicity and domination of man towards nature (Bacon, 1620a, b; Menna & Salvatico, 2000) (Fig. 5.2).

Therefore, it goes beyond the identification of complexity as ‘something which is complicated’ and, on the contrary, the transcendence is about affirming that the complex is an attribute of reality and it is irreducible to discrete entities too. There are proposals that value the dialectical units of the simple and the complex, the validation of chance, uncertainty, chaos, indeterminacy and emergence, non-linearity, etc. (Taeli, 2010). However, this paradigm of complexity not only conforms what reality is like to the ontological vision, but it also demands an epistemological coherence, complex thinking or non-classical rationality to be increasingly accepted. For decades, numerous journals, some open access or not, have addressed the main topics of mathematics education whose aims were to share, disseminate and discuss current trends, research results, experiences and perspectives in a wide range of mathematics education, mathematics teaching, development in mathematics instruction, the innovations in mathematics learning and current trends in mathematics

education research, etc. Obviously, due to reasons of length I will only cite some of these most popular journals:

- Educational Studies in Mathematics  
(An International Journal)<sup>1</sup>
- Digital Experiences in Mathematics Education<sup>2</sup>
- Journal for Research in Mathematics Education<sup>3</sup>
- Canadian Journal of Science, Mathematics and Technology Education<sup>4</sup>
- International Journal of Mathematical Education in Science and Technology<sup>5</sup>
- ZDM – Mathematics Education<sup>6</sup>
- International Electronic Journal of Mathematics Education<sup>7</sup>
- Teaching Mathematics and Its Applications<sup>8</sup>
- The Journal of Mathematical Behaviour<sup>9</sup>
- Research in Mathematics Education<sup>10</sup>
- Journal of Mathematics Teacher Education<sup>11</sup>

## Multicultural and Intercultural Approaches in the Classroom

Not many research projects, curriculum development efforts, or cross-cultural collaborations in mathematics education take seriously the notion that potentially confusing and complex multiplicities of cultures and identities manifest in what might at first glance be taken as a single “culture.” and monolithic. in contemporary, postcolonial, Creole “intercultural” contexts,.. (Appelbaum, 2008; Valero & Stentoft, 2010; Swanson & Appelbaum, 2012; Chronaki, 2005).

---

<sup>1</sup> <https://www.springer.com/journal/10649>

<sup>2</sup> <https://www.springer.com/journal/40751>

<sup>3</sup> <https://pubs.nctm.org/view/journals/jrme/jrme-overview.xml>

<sup>4</sup> <https://www.springer.com/journal/42330>

<sup>5</sup> <https://www.tandfonline.com/action/journalInformation?show=aimsScope&journalCode=tmes20>

<sup>6</sup> <https://www.springer.com/journal/11858>

<sup>7</sup> <https://www.iejme.com/>

<sup>8</sup> <https://academic.oup.com/teamat>

<sup>9</sup> <https://www.journals.elsevier.com/the-journal-of-mathematical-behavior>

<sup>10</sup> <https://www.tandfonline.com/action/journalInformation?show=aimsScope&journalCode=rme20>

<sup>11</sup> <https://www.springer.com/journal/10857>

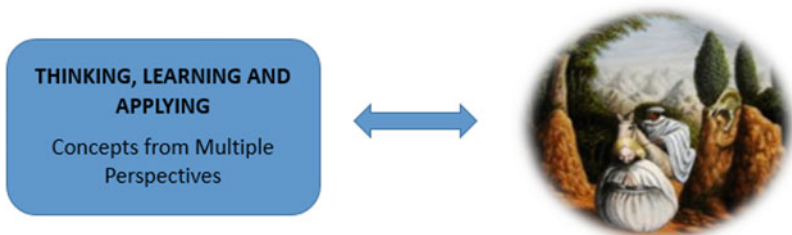
In (Swanson & Appelbaum, 2012), the analysis of the debates around the links between mathematics and democracy among the population can be pointed out; in general, they have not been explicitly tested well. A critical relationship around democracy in mathematics education can compromise the direction of its goals. Consequently, in the work cited, it is notable to point out the issues that arise, and that I personally want to review, quote: “. . . *what if the “option“ of not participating in experiences of mathematics education, or in its (re) direction, was also a critical relationship with mathematics education? What if this rejection and disobedience to the evocative power of mathematics were a democratic action? . . .*”

In Chap. 8 of this book (Appelbaum & Stathopoulou, 2022) it is analyzed how the few projects and study referents of the complexity of the notion of multiculturalism and interculturalism have not been clearly the object of investigation.

In this section we will do a brief analysis of different outlooks in multicultural and intercultural approaches in the classroom. We would like to make sure that making use of multicultural and intercultural approaches (Holm & Zilliacus, 2009) enriches both students and teachers since they are better understood and valued by promoting critical thinking, as students think about this topic more deeply and broadly. Multiculturalism is increasingly present in the classroom and this creates the need for teachers to have new challenges. Traditionally, students who participate in a multicultural class have to make an effort at the time of learning to live with unknown people, culture and language.

As a consequence, this implies that teachers must acquire the task and the commitment to direct students through that ‘strange’, unknown route which allows them to achieve the goals initially proposed thanks to specialized learning techniques. Classrooms with dynamic activities, both inside and outside the campus, are more likely to boost student achievement and to improve the negative aspects that were observed in multicultural classrooms in the past (Merfat, 2015) (Fig. 5.3).

When it comes to talking about multiculturalism and interculturality (Stan, 2020; Latour, 2010; Shkelzen, 2017), a brief reflection must be made since both concepts, in my opinion, present some differences between each other to be understood and effectively approached by the promotion of what democratic values may be.



**Fig. 5.3** S. Freud. (*St. George and the dragon*. Jósean Figueroa)

These differences mainly lie in the fact that interculturality is a much broader term that even encompasses multiculturalism.

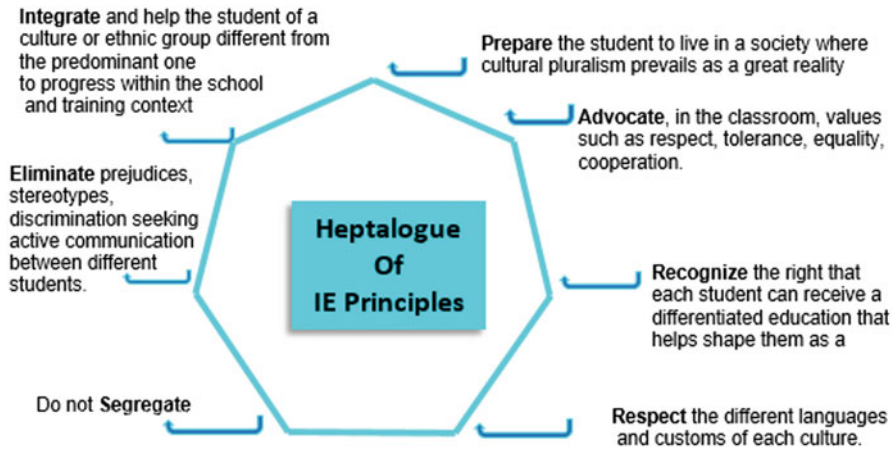
Therefore, it would be better to focus on the concept of ‘intercultural education’. A fully inclusive school goes one step beyond multicultural education. This is necessary to incorporate criticism and reflection so that students may be able to acquire values, such as respect for diversity, equality and dignity, apart from having a more empathetic vision to live with society as well. Some guidelines to follow would be:

- Educational proposals of a social nature
- Highlighting the similarities between cultures, and not only the differences
- Rejecting the hierarchy of cultures.
- Fostering relationships between individuals, groups and institutions of various cultures.
- Establishing common languages and shared rules that allow exchanges and facilities for interpersonal relationships, as well as the power of decision and participation.

And here mathematics education must play an important role. In order to achieve an education where all students are integrated, it is necessary that both in classrooms and in educational centers (Cole, 1996), formal and non-formal or intercultural, all groups from different cultures may be able to coexist based on equal treatment and respect for difference.

Diversity is a defining element of the dynamics of history and cultural richness sustained by the identities that are integrated into its cultural heritage linked to the social weft. The story of this diversity goes through the fight against racism, discrimination and stereotypes, along with equal access and enjoyment of Human Rights and Fundamental Freedoms. December 10, 2021 marked the 73rd anniversary of the adoption of the Universal Declaration of Human Rights (Resolution, 217-III, 1948) by the General Assembly. According to UNESCO, in a society where cultural diversity is part of the common heritage of mankind, communication and interaction between cultures is an essential need like biological diversity between living organisms, basic educational work to coexist freely, fair, egalitarian and dignified in everyone’s society that must be an indispensable objective of every Curriculum Project. Interculturality means the relationship between two or more cultures that establish ties in a horizontal, non-hierarchical way, creating synergies and sharing different points of view (Reynolds-Case, 2013). In a school where there is an increasing confluence of cultures due to higher rates of immigration, the educational response to this interculturality must be adequate and adapted. And this is possible when an Intercultural Education (IE) is applied in a school environment that benefits the coexistence between people of different cultures.

***As Heptalogue of IE Principles (Fig. 5.4)***



**Fig. 5.4** Heptalogue of IE Principles. (Heptalogue of IE Principles)

***How to Apply an Intercultural Education in a Mathematics Classroom***

The presence of a high number of students from different cultures in the classroom makes the work of the teacher more important when it comes to facilitate communication and relationships between students in order to provide a positive intercultural mathematics education. This is considered as a mission and a challenge in which all members of the educational community must collaborate like center staff, environment, family, etc.

The permanent training in mathematics by the teacher must keep being the transmission of pedagogical competences about how to program the classroom in a way that might be focused on interculturality, how to work with positive education, moderate conflicts, as well as proposing the resolution to problems associated with coexistence of cultures by presenting mathematical situations that are adapted to the procedural moment in which it is found. Thanks to a positive activity the teacher must be willing to successfully communicate her intercultural message, and promulgating confidence and security at the same time.

## ***Multicultural Mathematics: Teaching Mathematics from a Global Perspective***

For so long many researchers have been working on the need for teaching mathematics from a multicultural perspective. This approach can be applied to any school curriculum. Recognizing and appreciating the cultural heritage of minority students helps to build their confidence and pride. A multicultural approach to mathematics requires the acknowledgement of history of mathematics and recognizing the social and political values that shape the mathematics curriculum (Roth & Radford, 2011).

### ***How to Work with Intercultural Education***

The introduction of intercultural content in the didactic units of the different curricular areas, especially in mathematics, should serve to carry out cooperative activities in work groups by adapting them to the classroom and by developing materials that can favour their application (Salazar, 2009).

In the activities whose aims are the interaction and feedback between students of different ethnicities and cultures, an attempt will be made for an emotional development and a relational learning by contributing to the aforementioned values that promote reflection, dialogue, harmony, listening to the other person, empathy, as well as to adapt their skills to different environments, etc. (Velasco & Jablonska, 2010). A work that, if applied from the earliest educational stage, improves not only the quality of teaching but also enriches the very multicultural society where we find –and will find– ourselves. (CIEAEM, 70-Mostaganem, 2018).

Definitely, being the mestizo society, the multicultural reality is a condition of the way of life of the human species: we live in multicultural societies. As Gairín (2005) said, ‘. . . all societies have been multicultural. . .’ (sic). On the other hand, Ainscow (2001) made a very serious approach in his book *Development of inclusive schools. Ideas, proposals and experiences to improve school institutions*. This book offers many ideas, reflections, proposals and experiences to make schools and classrooms more inclusive, capable of reaching out to those students who encounter difficulties in their participation and learning. Also, in the interesting work *Developing inclusive education systems: What are the levers for change?* Ainscow (2004) argues that inclusion is the main challenge facing education systems around the world. This reflection provides a framework for determining factors that can help to facilitate systems in a more inclusive direction. As a consequence, strategies for developing inclusive practices must involve interruptions at the time of thinking to foster an exploration of overlooked possibilities.

Figure 5.5 helps us to get focused on the factors that influence inclusive developments within an education system. The debate on interculturality has strongly penetrated into the educational field in southern European countries. In Spain, the real emergence took place in 1992 and the initiatives of the administrations and

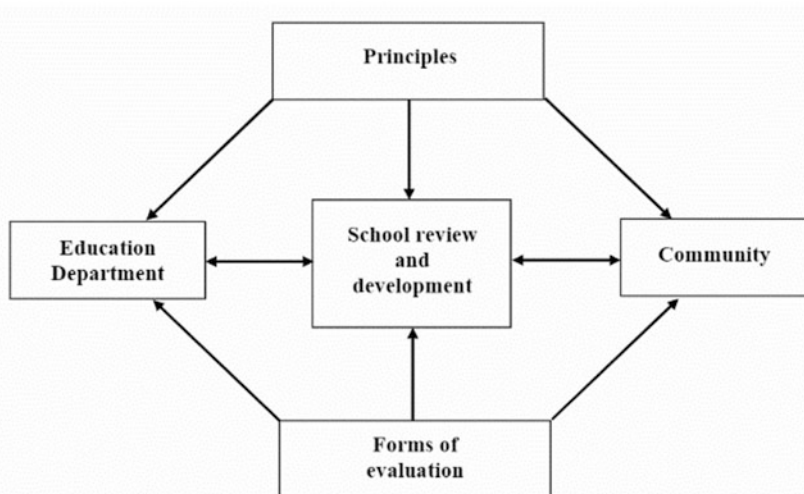


Fig. 5.5 Levers for change. Inclusive development. (Ainscow, 2004)

universities, publications and scientific meetings have been multiplying since then. I agree with the idea of interculturality of Xavier Besalú, 2002: *‘The best intercultural education is the full social recognition of cultural minorities. We cannot respond to political and social problems with educational solutions alone. Pedagogizing the most complex issues and challenges is still a cheap and easy resource, serving only to divert attention from the true causes of these problems. However, education can favor a rational understanding of conflicts and avoid irrational and unfair explanations and solutions...’* (sic)

It is about a new space, still non-existent, governed by new rules, born from negotiation and joint creativity (Carbonell, 1998). And, consequently, what pedagogical policies, teaching organizations and methodologies can concur to the achievement of fair, adequate solutions. In education there are three major theoretical-practical perspectives on how to approach interculturality in school: compensatory, multicultural and intercultural education.

## Cases in Developing Countries

There are many works and investigations that have been carried out in this respect of mathematics, diversity and cultural education. Today, in Latin America there are more than 600 indigenous tribes and minority groups, historically marginalized by educational systems and social policy, who obtain less successful results of learning achievement in mathematics. In order to promote equity in education and the relevance of learning and teaching processes, it is necessary to incorporate the

richness and cultural diversity of peoples into them. The works of the Peruvian Association for Research in Mathematical Education (Bonilla et al., 2018) highlight the importance of developing IBE-Intercultural Bilingual Education (López & Küper, 1999) and designing processes that use local mathematical knowledge, by making known the situation of Intercultural Bilingual Education in Chile (Peña & Hueitra, 2016) and Peru (Cáceres et al., 2016), as well as the bilingualism of deaf people in Brazil (Andreis-Witkoski, 2020), by developing aspects of its mathematical dimension and proposing alternatives which contribute to solve problems that may arise. Also, in Ecuador (MEE, 2013; Conejo, 2008; Bonilla et al., 2018) the IIBE System Model (MOSEIB) allows the promotion and development of the ancestral language and culture thanks to active, student-focused proposals by considering their learning rhythms, which is a contextualized learning in the social, mental, cultural and linguistic fields.

Not wanting to enter into controversy about the consideration of a developing country, and due to obvious reasons of space and the singularity of the research which has been carried out, we will present with certain details, as a significant example in the context of the issue addressed, an investigation that makes us focus our attention on social practices in an indigenous community.

### ***Case (a): The Use of Social and School Practices Within an Indigenous School***

The excellent ethnomathematical work (Jaramillo, 2009, 2013, 2014) by the University of Antioquia (Colombia) exemplifies other understandings about the forms of objectification of mathematical knowledge from a dialogue between social practices and school practices within the indigenous school

This is an investigation that analyzes the relationship that can appear between the social practices of planting by the Tule and Embera-Chamí indigenous peoples and the production of mathematical knowledge related to measurement in an indigenous school context. An interesting conclusion is the presentation of latent intercultural tensions that have not been solved yet, neither for researchers in this field nor for indigenous peoples (Fig. 5.6).

In this research project, the question that invited us was related to what interrelationships are woven, through mathematical knowledge, between the teaching processes and the learning processes, within the mathematics classroom. . . . A practice that makes it possible to explain the relationships between human action and social, cultural, political and historical situations, where such actions take place, and that enable the emergence of such knowledge. For its part, we understood the classroom as an encounter, where various subjects converge in a given space, time and sociocultural context - the three historical and political - where an interlocutory event has to take place, from the perspective of Gerdal (2000), around specific knowledge . . . (sic)

Jaramillo highlights in this analysis some ideas about the sociocultural perspective in mathematics education: knowledge is produced from the subject in their



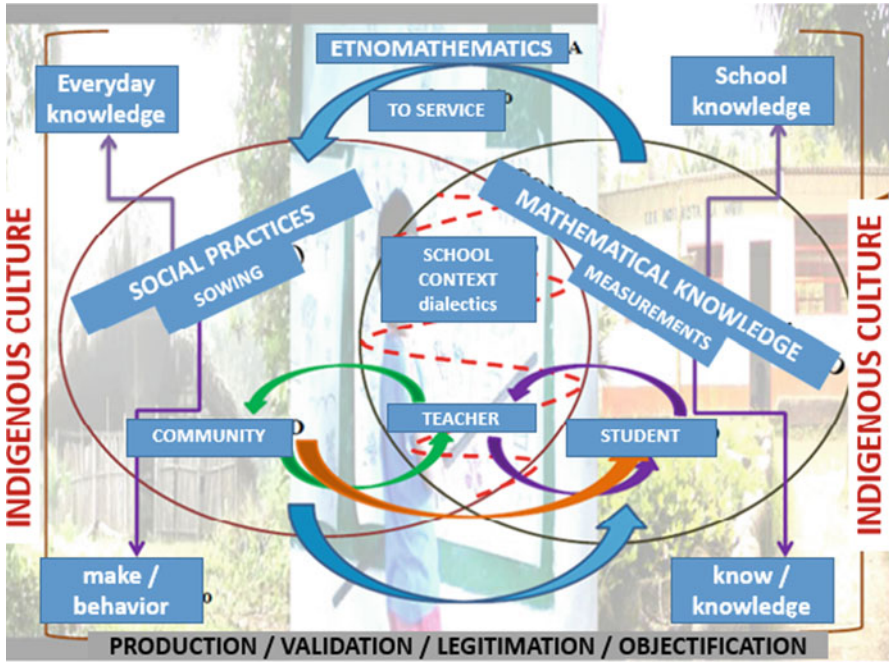


Fig. 5.6 Scheme Berrío Londoño, 2009. (Content translation: Romero, 2021)

interrelations with the world as a social activity, whose production and legitimation is the result of the explanation of different social practices in which the subjects are involved, based on the senses and shared meanings, thus respecting the different knowledge constituted by the various sociocultural groups.

From this sociocultural perspective, and according to some authors like Radford (2008), mathematics is seen as a product of human activity that is formed during the development of solutions to problems which are created in the interactions that produce the human way of living socially, always in a given time and context.

When it comes to teaching and learning mathematics, there are some important and basic relationships between culture, the curriculum and mathematics education to be taken into consideration. The discussion of these relationships can be possible thanks to some questions (Jaramillo, 2011):

- What sociocultural factors that can make possible mathematical knowledge must be considered, by influencing the educational processes of the teaching/learning of mathematics binomial when they are introduced in the classroom?
- What would happen if we looked at mathematics from social practices instead of looking at social practices from mathematics?
- How can mathematical activity be understood in the production and objectification of mathematical knowledge?

- What are the relationships between knowledge, behaviour and culture in the objectification of mathematical knowledge?

I personally agree with the conclusion that Radford reached to when he stated: ‘... *These questions are not new in education, perhaps they are for mathematical educators, they try to rescue subjectivity when practicing pedagogy, in their praxis, in mathematics. In this sociocultural perspective of mathematics education, the recovery of the subject and subjectivity in the educational act is sought. Use is made of the dyad used by Freire (2000), complaint-advertisement. A reality is denounced to announce a possibility, a utopia or a dream...*’. In this sense, Radford (2008) drew attention to the need to think about mathematics on a basis which would assume knowing as the result of human activity from a historical, social and cultural point of view.

### ***Case (b): Afro-Colombian Studies and Basic Standards in Competencies***

#### **Intercultural Dialogue**

This look at ethnomathematics and mathematics education in Colombia (Blanco-Álvarez et al., 2014) presents an interesting document about the path travelled by students, teachers and researchers (Oliveras et al., 2013) in the field of ethnomathematics and the relationships with mathematics education. It is about reflection, study and travel through different cultures: (a) making specific, curricular proposals that legitimize intercultural dialogue regarding the different ways of being and doing in a complex, diverse country like Colombia; (b) creating and proposing public policies in accordance with local needs and interests.

Besides, it is also interesting the study of the Chair of Afro-Colombian Studies (CEA) in the context of education for citizenship and coexistence, which has been carried out under the direction of Ángela Patricia Valencia Salas. This study has been stated despite the sociocultural character of mathematics since the seventeenth century:

They have been introduced as a universal, decontextualized and abstract knowledge, based on formal logic. Their criteria have been applied to the thought systems of other non-Western cultures, and this way it has been argued that their explanations of the world are inconsistent, absurd, false or pre-logical (Páramo, 1996).

As we indicated in the introduction, in this work, all peoples have developed a mathematical thought in relation to their vital context, both from a theoretical and practical point of view, in short: a knowledge with its own logic.

Thus, ethnomathematics shows us a variety of models and explanations of the world, not only ours, but also of multiple others, and this is why teaching provides the student with tools for understanding and intercultural dialogue. Therefore, it is possible to carry out a research within Afro-descendant communities, street children,

indigenous communities, mathematicians, carpenters, bricklayers, peasants, dress-makers, etc., or any other cultural group whose practices will turn out to be another cultural group who will study according to the interests of the communities who the research may be carried out with. (Blanco-Álvarez, 2006, 2011, 2012; Blanco-Álvarez et al., 2014).

The aim of this relationship between mathematical knowledge and reality is constantly being researched, and also to highlight the knowledge of peoples that make possible the search and proposals of new pedagogical perspectives in order to make from the teaching of mathematics an inclusive, intercultural and participatory process (Jaramillo, 2011) which may incorporate the contributions of the African, Afro-diasporic and, especially, Afro-Colombian peoples. African and Afro-diasporic ethnomathematics is the set of mathematical ideas that African-origin different cultures have developed, based on the experience that men and women have had with their environment and relationships; and these ideas are also materialized in mathematical activities such as counting, measuring, estimating, classifying, or predicting, amongst others.

Eugenio Nkogo (2001), in his book *Systematic Synthesis of African Philosophy*, described the wisdom of the Dogon people, a community from Mali that contained precise and detailed data on the solar system.

The synthesis of African philosophy provides surprising data on the origin of Western culture. The common thread lies in the fact that the Egyptian and Greek cultural nourishing source was in African culture: the first essential achievements of the human condition, oral and written language, the emergence of systematized thought, as well as the ethical and artistic dimension of the human race took place in African territories. In great depth, Eugenio Nkogo showed that humanistic civilization came from Africa to the West through Egypt and Rome (Nkogo, 2001, p. 196–197).

The work of the CEA rescues the sociocultural character (Valero, 2004) and mathematics by taking into consideration: what is the use of rescuing the sociocultural character of mathematics for? Why is it useful to the teaching of mathematics the re-establishment of its sociocultural character? This can be used to make visible the mathematical knowledge which is present in all cultures as a way to provoke critical reflections in students that may allow them to recognize their own mathematical knowledge, their ability to think mathematically about reality and to solve everyday situations and problems.

It is part of an educational policy whose main purpose is to highlight, to transmit and to recover the contributions of Afro-descendant peoples to knowledge, values, or relationships between communities and nature which had been invisible, undervalued or denied:

The history of mathematics has not set apart from these processes of little visibility. For example, Pythagoras and Thales of Miletus, the great Greek mathematicians who were of Phoenician descent, learned and worked with wise African mathematicians; it is unknown that the oldest mathematical object of mankind (dated 35.000 years B.C.) was found in Eswatini (ancient Swaziland, Southern Africa): a

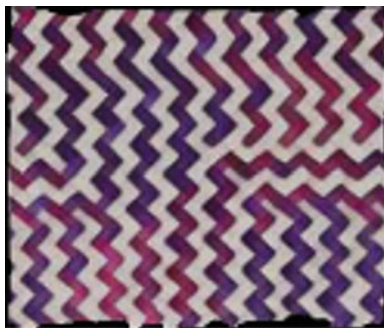
chuck bone fragment marked with 29 notches that served to keep time ([Ikuska.com](http://Ikuska.com), 2013), which is also a calendar still used by some Khoisan groups in Namibia.

### Some Mathematical Competencies in the Project (CEA)

Competencies that include symbolic systems, spatial designs, techniques, construction practices, calculation methods, models and measurements of time and space, specific forms of reasoning, and other problems and material activities, were developed in different peoples of the African continent. Also, it shows how this type of thinking is linked to the sociocultural practices of African peoples and responds to their needs, for example: (a) order, classification and set theory: a mathematical critique of race and gender; (b) spatial thinking: geometric figures, patterns, symmetry and asymmetry. Throughout history human beings learned to use geometry in work contexts and needs. In this sense, it seems that geometric exploration was par excellence a mathematical activity in the history of central and southern Africa. A reflection on this can be appreciated in the artistic and geometric work of mat and basket weaving, ceramics, beadwork, painting, wall ornamentation, hair braiding, tattoos, wood sculpture and architecture, by specifically exploring rotational symmetry patterns. Amongst these geometric explorations we must mention: *sipatsi*, *sona* and *litema*.

1. Tonga women from the province of Inhambane (South Mozambique) use a diagonal weaving technique to make handbags called *sipatsi*. These crafts are made with various mental calculations before crisscrossing starts. If there is no exact or positive solution, an approximate solution will be sought. (Gerdes, 2004, 2007, 2014) (Figs. 5.7, and 5.8).
2. The study of the *sona* drawings (*lusona*, singular) leads us to the historical dimension of ethnomathematics. This tradition of sand designs was developed amongst the Chokwe of North East Angola (Gerdes, 2007; Chavey, 2009) (Figs. 5.9, and 5.10).
3. This is another example of creation of geometric patterns that are used by some peoples who live in South Africa and Lesotho today. The *litema* are creations

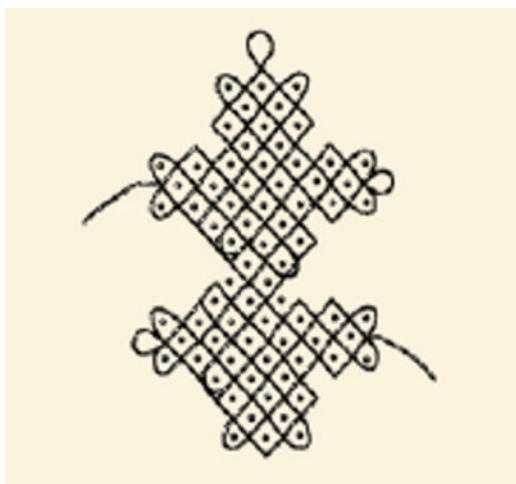
Fig. 5.7 *Sipatsi* tissue



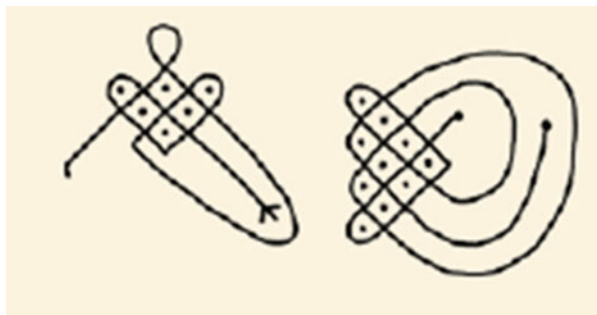
**Fig. 5.8** Base of *sipatsi* basket

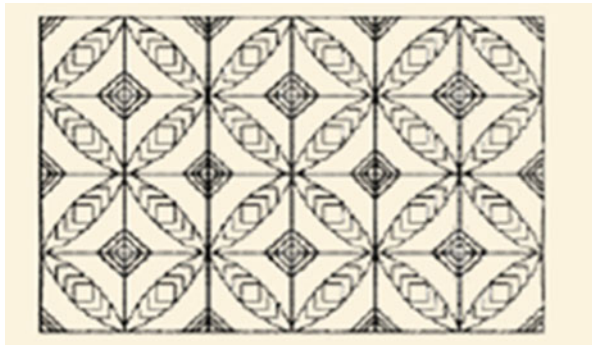


**Fig. 5.9** *Sona*  
Non-monolinear



**Fig. 5.10** *Sona* basic  
design Triangular



**Fig. 5.11** *Litema*

mainly made by women to decorate their homes, and the motifs come up from the observation of nature and its surroundings (Fig. 5.11).

## Conclusion

Unanimity is noticeable in the opinion of the world-wide mathematical community about the creation of a way to approach reality thanks to mathematics, by providing important elements for the development of the capacity related to rational argumentation, reflective abstraction and the increase of the skills which are needed for problem solving, not only in the school environment but also of wide application and transfer to other fields of knowledge. It represents a valid argument for mathematics education and for the promotion and revitalization of research initiatives in this field too, both in studies related to epistemology and those ones which are close to teaching practice. The advance in mathematics education has been consolidated as a field of study, which has been progressively evolving in order to make from itself a scientific perspective rather than a philosophical one, thus reaching ‘the necessary experience’ to have its own identity.

Finally, as evidenced by reading other chapters of this book, it is important to value the need for a thorough analysis of the diversity of cultures so that they are included in curricular designs as well as taken into account by the educational community, which means that a multicultural approach can potentially enrich both students and teachers. We must focus our attention on a school where every day there is more confluence of cultures and the educational response to this interculturality must be adequate and adapted. And this is possible when an education that promotes coexistence between people of different cultures is applied, presented as a heptalogue. Also, and by way of example, some experiences carried out in disadvantaged environments in developing countries have been presented, such as the use of social and school practices within an indigenous school.

## References

- Ainscow, M. (2001). *Desarrollo de escuelas inclusivas. Ideas, propuestas y experiencias para mejorar las instituciones escolares*. Ed. Narcea.
- Ainscow, M. (2004). Developing inclusive education systems: What are the levers for change? *Journal Education Change*, 6, 109–124. <https://doi.org/10.1007/s10833-005-1298-4>
- Andersen, L. R. (2019). *The Bildung Rose*. <https://nordicbildung.org/papers/the-bildung-rose/>
- Andersen, L. R. (2020). *Bildung: Keep Growing*. Nordic Bildung. Report to the Club Rome, 171. <http://nordicbildung.org/books/bildung/>
- Andreis-Witkoski, S. (2020). Desafios no processo de letramento de alunos surdos (Challenges in the process of literacy of deaf students). *Revista (Con)Textos Linguísticos, Vitória*, 14(27), 309–311. <https://www.educacion.gob.ec/wp-content/uploads/downloads/2014/03/MOSEIB.pdf>
- Appelbaum, P. (2008). *Embracing mathematics: On becoming a teacher and changing with mathematics*. Routledge.
- Appelbaum, P., & Stathopoulou, C. (2022). History of Ethnomathematics: Recent developments. Chapter 8. In *The role of the history of mathematics in the teaching learning process*.
- Arcavi, A. (1991). *Two benefits of using history. For the learning of mathematics* (Vol. 11, N<sup>o</sup>, pp 11). Flm.
- Bacon, F. (1620a). Novum Organum. In Ed. Losada-2004. *Buenos Aires* (Argentina).
- Bacon, F. (1620b). Novum Organum, Ed. by Joseph Devey, M.A. -1902 (P.F. Collier). <https://oll.libertyfund.org/title/bacon-novum-organum>
- Barwell, R. et al. (Eds.) (2016). *Mathematics Education and Language Diversity. The 21st ICMI Study*. Springer. <https://link.springer.com/book/10.1007/978-3-319-14511-2>
- Berrío Londoño, K. (2009). *La medida en un contexto de escuela indígena. El caso de la comunidad tule y el caso de la comunidad Ember-Chami*. Trabajo de Grado no publicado, Universidad de Antioquia.
- Besalú, X. (2002). Educación intercultural. En, *Diversidad Cultural y Educación*. THE. Ed. Síntesis.
- Blanco-Álvarez, H. (2006). La Etnomatemática en Colombia. Un programa en construcción. *Revista Bolema: Boletim de Educação Matemática*, 19(26), 49–75.
- Blanco-Álvarez, H. (2011). La postura sociocultural de la educación matemática y sus implicaciones en la escuela. *Revista Educación y Pedagogía*, 23(59), 59–66.
- Blanco-Álvarez, H. (2012). Estudio de las actitudes hacia una postura sociocultural y política de la Educación Matemática en maestros en formación inicial. *REDIMAT – Journal of Research in Mathematics Education*, 1(1), 57–78.
- Blanco-Álvarez, H., Higueta Ramírez, C., & Oliveras, M. L. (2014). Una mirada a la Etnomatemática y la Educación Matemática en Colombia: caminos recorridos. *Revista Latinoamericana de Etnomatemática*, 7(2), 245–269.
- Bonilla, M. C., Milton, R., Aucacahuallpa, R., & Reyes, M. E. (2018). *La dimensión matemática en educación intercultural bilingüe: educación matemática y diversidad*. APINEMA (Asociación Peruana de Investigación en Educación Matemática), Universidad de Federal de Ouro Preto, Universidad Nacional de Educación, Complejo Educacional Consolidada (Vol. 31, N<sup>o</sup> 2). Acta Latino americana de Matemática Educativa. ALME). <https://www.alme.org.mx/alme32v1/index.php>, <https://es.scribd.com/document/446060781/alme31-2-pdf>
- Bréhier, E. (1926). *Histoire de la Philosophie*. In. Presses Iniversitaires de France. Ed. F. Alcan. <https://archive.org/details/histoiredelaphil00br/page/6/mode/2up?ref=ol&view=theater>, [https://archive.org/stream/histoiredelaphil00br/histoiredelaphil00br\\_djvu.txt](https://archive.org/stream/histoiredelaphil00br/histoiredelaphil00br_djvu.txt), <https://ia802606.us.archive.org/5/items/histoiredelaphil00br/histoiredelaphil00br.pdf>
- Cáceres, R., Cavero, O., & Gutiérrez, D. (2016). *Diagnóstico descriptivo de la situación de los pueblos originarios y de la política de Educación Intercultural Bilingüe en el Perú*. Ministerio de Educación.

- Carbonell, F. (1998). *Minories culturals (i lingüístiques) a l'escola ara i aquí. Condicionants sociopolítics i reptes educatius*. En Aznar, S., Buesa, S. y Terradellas, 33–34 M. R. (Coord.). Primer Simposi: Llengua, Educació i Inmigració. Universitat de Girona.
- Castro, J. (2007). *La investigación en educación matemática: una hipótesis de trabajo*. EDUCERE Investigación arbitrada. Vol. 11, N° 38, 201–230. Universidad de Los Andes.
- Chavey, D. (2009). *Mathematical experiments with African Sona Designs. Bridges 2009: Mathematics, music, art, architecture, culture* (pp. 305–308).
- Chronaki, A. (2005). Learning about 'learning identities' in the school arithmetic practice: The experience of two young minority Gypsy girls in the Greek context of education. *European Journal of Psychology of Education*, 20(1), 61–74.
- CIEAEM 70. (2018). *Mathematics and living together: Why, how, what?* <https://www.cieaem.org/index.php/en/meetings-en/2018-mostaganem-en>
- Claireaut, A.-C. (1741). *Éléments de Géométrie*. Académie Royale des Sciences et de la Société Royale de Londres. Chez David Fils. <https://archive.org/details/elementsdegeomet00claigoog/page/n6/mode/2up>
- Clark, K., et al. (2016). *History of mathematics in mathematics education. Recent developments. History and Pedagogy of Mathematics*. <https://hal.archives-ouvertes.fr/hal-01349230>
- Cofunded by Erasmus. (2021). *Programme of the European Unión*. <https://eaea.org/wp-content/uploads/2021/02/Bildung-spanish.pdf>
- Cole, M. (1996). *Psicología cultural*. The Belknap Press de Harvard University Press.
- Conejo, A. (2008). *Educación Intercultural Bilingüe en el Ecuador, La propuesta educativa y su proceso* (pp. 64–82). Comunicación y Sociedad. <https://dspace.ups.edu.ec/bitstream/123456789/8090/1/Educaci%C3%B3n%20intercultural%20biling%C3%BCe%20en%20el%20Ecuador.pdf>
- Davidman, L., & Davidman, P. T. (1994). *Teaching with a multicultural perspective: A practical guide* (2nd ed.). California Polytechnic State University. [https://www.abebooks.com/servlet/BookDetailsPL?bi=30725392057&searchurl=an%3Ddavidman%2Bleonard%2Bdavidman%2Bpatricia%2Bt%26sortby%3D17&cm\\_sp=snippet\\_-\\_srp1\\_-\\_title1](https://www.abebooks.com/servlet/BookDetailsPL?bi=30725392057&searchurl=an%3Ddavidman%2Bleonard%2Bdavidman%2Bpatricia%2Bt%26sortby%3D17&cm_sp=snippet_-_srp1_-_title1)
- de Guzmán, M. (1993). Enseñanza de las ciencias y la matemática: tendencias e innovaciones. Daniel Gil Pérez, Miguel de Guzmán Ozámiz. Publisher: Editorial Popular. Editor: OEI. Organización de estados Iberoamericanos para la Educación, la Ciencia y la Cultura.
- de Guzmán, M. (1996). Una breve descripción de la Comisión Internacional de Educación Matemática y de sus actividades. *Rev. Suma. Enseñanza y aprendizaje de las Matemáticas*, 22, 5–8.
- De Guzmán, M. (2001). *Tendencias actuales de la educación matemática*. Universidad Complutense de Madrid. *Rev. SIGMA-1* (pp. 5–25). [https://www.euskara.euskadi.eus/contenidos/informacion/dia6\\_sigma/eu\\_sigma/adjuntos/sigma\\_19/3\\_Educacion\\_Matematica.pdf](https://www.euskara.euskadi.eus/contenidos/informacion/dia6_sigma/eu_sigma/adjuntos/sigma_19/3_Educacion_Matematica.pdf), <http://www.mdeguzman.net>
- Dickenson-Jones, A. (2008). Transforming ethnomathematical ideas in western mathematics curriculum texts. *Mathematics Education Research Journal*, 20(3), 32–53. James Cook University.
- Ernest, P. (1998, Sept.). The history of mathematics in the classroom. *Mathematics in School* 27(4), *History of Mathematics*, pp. 25–31. <https://www.jstor.org/stable/30211871>.
- Fauvel, J. (1991). Using history in mathematics education. *For the learning of mathematics*, 11(2), 3–6. FLM Publishing Association. <https://www.jstor.org/stable/40248010>
- Freire, P. (2000). *Pedagogia da autonomia: saberes necessários à prática educativa*. 7 ed. Paz e Terra (original de 1996).
- Fried, M. N. (2018). History of mathematics, mathematics education, and the liberal arts. In G. Kaiser, H. Forgasz, M. Graven, A. Kuzniak, E. Simmt, & B. Xu (Eds.), *Invited lectures from the 13th international congress on mathematical education. ICME-13 monographs*. Springer. [https://doi.org/10.1007/978-3-319-72170-5\\_6](https://doi.org/10.1007/978-3-319-72170-5_6)
- Furinghetti, F., & Somaglia, A. (1997). History of mathematics in school acrossdisciplines. *Mathematics in School*, 27(4), 48–51.



- Gairín, J. (2005). Organizar la escuela intercultural una exigencia del futuro. Actas Congreso Iberoamericano de Pedagogía. Ed. Sociedad Española de Pedagogía. En Vol. 1. *La educación en contextos multiculturales. Diversidad e identidad*. Sec. IV. Instituciones y escenarios para un currículum multicultural conferencias, mesas redondas y talleres. 273, 329.
- Geraldi, J. W. (2000). *Portos de Passagem*. 4 ed. São Paulo: Martins Fontes, (original de 1991).
- Gerdes, P. (2004). *Plaited strip patterns on Tonga handbags in Inhambane*. <http://www.mi.sanu.ac.rs/vismath/gerdbook/gerdtongastrip/#421>
- Gerdes, P. (2007). *Etnomatemática: Reflexões sobre Matemática e Diversidade Cultural*. Portuga, Edições Húmus.
- Gerdes, P. (2014). Reflexões sobre o ensino da matemática e diversidade cultural. *Revista Latinoamericana de Etnomatemática*, 7(2), 108–118. <https://www.revista.etnomatematica.org/index.php/RevLatEm/article/view/124/328>
- Godino, J. D. (2004). Didáctica de las matemáticas para maestros. Departamento de Didáctica de las Matemáticas. Universidad de Granada. <http://www.ugr.es/local/jgodino/>
- Gravemeijer, K. P. E. (1994). *Developing realistic mathematics education*. Center for Science and Mathematics Education, Freudenthal Institute, Research Group On Mathematic Education. Utrecht University.
- Holm, G., & Zilliacus, H. (2009). Multicultural education and intercultural education: Is there a difference? In M. Talib, J. Loima, H. Paavola, & S. Patrikainen (Eds.), *Dialogues on diversity and global education* (pp. 11–28). Peter Lang. [https://www.researchgate.net/publication/281555019\\_Multicultural\\_education\\_and\\_intercultural\\_education\\_Is\\_there\\_a\\_difference](https://www.researchgate.net/publication/281555019_Multicultural_education_and_intercultural_education_Is_there_a_difference)
- Jaramillo, D. (2009). *Educación Matemática, Diversidad y Cultura: un ejemplo desde las prácticas sociales y las prácticas escolares en una escuela indígena*. Matemática, Educación y Sociedad-MES. Facultad de Educación. Universidad de Antioquia. Medellín (Colombia). Ponencia Central Mesa Matemática, diversidad y cultura. <https://www.udea.edu.co/wps/portal/udea/web/inicio/investigacion/grupos-investigacion/ciencias-sociales/mes>, [https://scienti.minciencias.gov.co/cvlac/visualizador/generarCurriculoCv.do?cod\\_rh=0000291013](https://scienti.minciencias.gov.co/cvlac/visualizador/generarCurriculoCv.do?cod_rh=0000291013), <http://soda.ustadistancia.edu.co/enlinea/congreso/Coloquio/MemoriasColoquio/Documentos/INTERCULTURALIDAD/Ponencia%20Central%20Mesa%20Matematica,%20diversidad%20y%20cultura%20-%20Diana%20Jaramillo.pdf>
- Jaramillo, D. (2011). La educación matemática en una perspectiva sociocultural: tensiones, utopías, futuros posibles. *Revista Educación y Pedagogía*, 23(59), 13–36.
- Jaramillo, D. (2013). La constitución de la subjetividad del maestro que enseña matemáticas, desde y para la Actividad Pedagógica. Educación científica y tecnológica Universidad Distrital Francisco José de Caldas. Revista Científica. Octubre de 2013. Ed. Especial.
- Jaramillo, D. (2014). La movilización de objetos culturales desde las memorias de la práctica de la construcción del purradé: elementos para otra discusión en educación (matemática) indígena. *Revista Latinoamericana de Etnomatemática: Perspectivas Socioculturales de la Educación Matemática*, 7(3), 8–32.
- Karp, A. (2016). Reflecting on the current issues in mathematics education. In *Current issues in mathematics education* (pp. 1–12). Materials of the American-Russian Workshop. [https://www.comap.com/Free/C\\_I\\_IN\\_MAT\\_ED/PDF/CURRENT\\_ISSUES\\_IN\\_MAT\\_EDUCATION.pdf](https://www.comap.com/Free/C_I_IN_MAT_ED/PDF/CURRENT_ISSUES_IN_MAT_EDUCATION.pdf)
- Keitel, C. (2004). *La enseñanza de las matemáticas en la sociedad del conocimiento o ¿Cuánta matemática necesita un Primer Ministro? Las Matemáticas en la Era del conocimiento*. Actas del XI CEAM. Ed. Sociedad Andaluza de Educación Matemática Thales. Huelva. ISBN:84–933040. Huelva (España).
- Keitel, C. (2006). *Perceptions of mathematics and mathematics education in the course of history – A review of western perspectives*. [https://link.springer.com/chapter/10.1007/0-387-29723-5\\_5](https://link.springer.com/chapter/10.1007/0-387-29723-5_5)
- Latour, A. (2010). *L'éducation interculturelle: qu'en pensent les enseignants oeuvrant en milieu homogène?* Université du Québec à Trois-Rivières.
- López, L., & Küper, W. (1999). La educación intercultural bilingüe en América Latina: balance y perspectivas. *Revista Iberoamericana de Educación*, 20, 85.

- Lorenzo, J. (2016). Renovación pedagógica en Aragón: estudio de caso del movimiento de renovación pedagógica “aula libre” entre 1975 y 2012. *Tendencias Pedagógicas*, 27, 201–230.
- Luengo, H. (2018). *Cambios en la Educación*. Diario de avisos. El Español. <https://diariodeavisos.elspanol.com/2018/03/cambios-la-educacion/>
- MECyD. (2006). *Enfoques actuales en la Didáctica de las matemáticas*. Instituto Superior de Educación. Ministerio de Educación, Cultura y Deporte. Área de Educación. <https://sede.educacion.gob.es/publivena/enfoques-actuales-en-la-didactica-de-las-matematicas/ciencia/12128>
- Menna, S., & Salvatico, L. (2000). *Rationality and methodology in bacon's Novum Organum* (Cuadernos no 15) (pp. 139–144). Facultad Humanidades y Ciencias Sociales. Universidad de Jujuy.
- Merfat, A. (2015). Examples of current issues in the multicultural classroom. *Journal of Education and Practice*. IISTE, 6(10), 87–88.
- MEE. (2013). Modelo de excelencia ecuatoriano y su relación con el desarrollo institucional del sector público local. <https://servicios.inclusion.gob.ec/intranet/index.php/gestion-de-calidad/modelo-ecuatoriano-de-excelencia>
- NCTM. (2000). The bibliographical citation appears in the web address: <https://www.springer.com/journal/42330>
- Nelson, D. et al. (1993). *Multicultural mathematics: Teaching mathematics from a global perspective*. *The mathematical Gazette* (Vol.79. ERIC Number: ED365767). <https://eric.ed.gov/?id=ED365767>
- Nkogo, E. (2001). *Síntesis sistemática de la filosofía africana*. Ediciones Carena. <https://gratis.e-detective.de/descargar/233489-eugenio-nkogo/>
- Oliveras, M. L., Blanco-Álvarez, H., & Palhares, P. (2013). ¿Hay matemáticas fuera de la escuela?: reflexiones de maestros de matemáticas en ejercicio. *Revista Científica*, Edición especial. 417–421.
- Palenzuela, H. (2016–2017). *¿Por qué incluir la Historia de la Matemática en el aula?* Máster en Profesorado de Educación Secundaria Obligatoria y Bachillerato, Formación Profesional y Enseñanza de Idiomas, 4–12. Universidad de Almería (España).
- Páramo, G. (1996). Mito, lógica y geometría. En: C.B. Gutiérrez. (Ed.). *El trabajo filosófico de hoy en el continente*. Memorias del XIII Congreso Interamericano de Filosofía. Bogotá. Universidad de los Andes.
- Peña, P., & Hueitra, Y. (2016). Conocimientos [matemáticos] mapuche desde la perspectiva de los educadores tradicionales de la comuna de El Bosque. *Revista Latinoamericana de Etnomatemática*, 9(1), 8–25.
- Radford, L. (2008). The ethics of being and knowing: Towards a cultural theory of learning. In L. Radford, G. Schubring, & F. Seeger (Eds.), *Semiotics in mathematics education: Epistemology, history, classroom, and culture*. Sense Publishers.
- Resolución 217-III. (1948). *Universal Declaration of Human Rights (UDHR)* (pp. 34–38). [https://undocs.org/es/A/RES/217\(III\)](https://undocs.org/es/A/RES/217(III))
- Reynolds-Case, A. (2013). The value of short-term study abroad: An increase in students' cultural and pragmatic competency. *Foreign Language Annals*, 46(2), 311–322.
- Romero, S. (2016). Situaciones reales. . .SAPERE AUDE a través de la Modelización Matemática. *Proceedings XVI CEAM. Conferencia Clausura*. <https://thales.cica.es/xviceam/actas/pdf/actas.pdf>
- Romero S. (2019). An introduction to the theory of complexity: case study with dynamic systems and fractality. *Proceedings CIEAEM-71. Quaderni di Ricerca in Didattica*. [http://math.unipa.it/~grim/quaderno\\_2020\\_numspec\\_7.htm](http://math.unipa.it/~grim/quaderno_2020_numspec_7.htm)
- Romero, S. (2020). An introduction to the theory of complexity: A case study with dynamic systems and fractality. *Quaderni di Ricerca in Didattica (Mathematics)*, Número Speciale, 7, 127–138. G.R.I.M. Dipartimento di Matematica, University of Palermo.

- Roth, W. M., & Radford, L. (2011). *A cultural-historical perspective on mathematics teaching and learning. Computer science, mathematics.* <https://www.appf.edu.es/ensenanza-para-todas-las-culturas/>
- Salazar, M. J. (2009). *Multiculturalidad e interculturalidad en el ámbito educativo: experiencia de países latinoamericanos* (pp. 13–26). IIDH. Instituto interamericano de Derechos Humanos.
- Santaló, L. A. (1994). *Enfoques hacia una didáctica humanista de la matemática*. Edición Troquel.
- Scheler, M. (1934). El saber y la cultura. *Revista de Occidente*. En *Colección: Nuevos Hechos-Nuevas Ideas IX*. <https://archive.org/details/scheler-max.-el-saber-y-la-cultura-ocr-1939/page/n1/mode/2up>
- Shkelzen, H. (2017). Multiculturalism vs Interculturalism: New Paradigm? (Sociologic and Juridical Aspects of the Debate between the two Paradigms)? University of Pisa Italy. *Journal of Education & Social Policy*, 4, 171–172.
- Siu, M. K. (1997). *The ABCD of using history of mathematics in the (undergraduate) classroom.* *Bulletin of Hong Kong Mathematical Society* (pp. 1–4, 12). Department of Mathematics University of Hong Kong. <https://citeseerx.ist.psu.edu/viewdoc/download?doi=10.1.1.563.1225&rep=rep1&type=pdf>
- Siu, F. K., & Siu, M. K. (1979). History of mathematics and its relation to mathematical education (1979). *International Journal of Mathematical Education in Science and Technology.*, 10(4), 561–567. <https://eric.ed.gov/?id=EJ216698>
- Stan, C. (2020). Multiculturality and interculturality in the educational system. *Educatia 21 Journal*, 19, 149–153. <http://educatia21.reviste.ubbcluj.ro/data/uploads/article/2020ed21-no19-art19.pdf>
- Swanson, D., & Appelbaum, P. (2012). Refusal as a democratic catalyst for mathematics education development. *Pythagoras*, 33(2), 1–6. <http://www.pythagoras.org.za/index.php/pythagoras/article/view/189>
- Taeli, F. (2010). The new paradigm of complexity and education: an historical glance. *Polis Revista Latinoamericana.*, 25, 2–13. <http://polis.revues.org/400>
- Tzanakis, C., et al. (2002). Integrating history of mathematics in the classroom: an analytic survey. In J. Fauvel & J. Van Maanen (Eds.), *History in mathematics education* (New ICMI Study Series, Vol. 6. Chap. 7). Springer.
- Uy, F. L. (2000). *Teaching mathematics concepts using a multicultural approach*. California State University. [https://learning.educatetogether.ie/pluginfile.php/12854/mod\\_resource/content/1/Teaching%20Mathematics%20Concepts%20with%20a%20Multicultural%20Approach.pdf](https://learning.educatetogether.ie/pluginfile.php/12854/mod_resource/content/1/Teaching%20Mathematics%20Concepts%20with%20a%20Multicultural%20Approach.pdf)
- Valero, P. (2004). Socio-political perspectives on mathematics education. En P. Valero, & R. Zevenbergen (Edits.) *Researching the socio-political dimensions of mathematics education: Issues of power in theory and methodology*. Kluwer Academic Publishers.
- Valero, P., & Stenoft, D. (2010). The ‘post’ move of critical mathematics education. In *Critical mathematics education: Past, present and future*. Brill Sense.
- Velasco, S., & Jablonska, A. C. (2010). *Construcción de políticas educativas interculturales en México: debates, tendencias, problemas, desafíos*. En *Horizontes Educativos*. Universidad Pedagógica Nacional.
- Zaslavsky, C. (1996). *Multicultural Math Classroom, Bringing in the World*. Heinemann. <https://eric.ed.gov/?id=ED393667>

# Chapter 6

## Integrating the History of Mathematics in Mathematics Education: Examples and Reflections from the Classroom



Sonia Kafoussi and Christina Margaritidou

**Abstract** This chapter presents examples for the design, implementation and assessment of mathematical activities based on the history of mathematics during the teaching of school mathematics in primary and low secondary education. Our main concern is the investigation of learning opportunities that such activities could provide for mathematical discussions among the members of the classroom concerning history as a goal and/or history as a tool. The empirical evidence comes from a third class of junior high school concerning the relation of Babylonians and Al-Khwarizmi with the solution of a quadratic equation as well as from a fourth grade of a primary school, where the students were engaged in activities referred to the Babylonian and ancient Egyptian symbols about numbers.

**Keywords** History of mathematics · Primary mathematics education · Middle school mathematics · Classroom discourse

### Introduction

In recent decades the interest of mathematics educators in the ways that the history of mathematics can help and improve mathematics education, is continuously increasing, as there are a lot of discussions about the coexistence of mathematics education and history of mathematics in the mathematics classroom (see for example Clark et al., 2016; Fried, 2001; Jankvist, 2009, 2010; Wang et al., 2018). According to Jankvist (2009) “the arguments for using history are of two different kinds: those that refer to history as a tool for assisting the actual learning and teaching of mathematics, and those that refer to history as a goal in itself” (p.237). The first category -that refers to history as a tool- is mainly connected with arguments that consider history as a motivational or/and as a cognitive tool (e.g. the idea of epistemological

---

S. Kafoussi (✉) · C. Margaritidou  
Department of Sciences of Pre-School Education and of Educational Design,  
University of the Aegean, Rhodes, Greece  
e-mail: [Kafoussi@aegean.gr](mailto:Kafoussi@aegean.gr); [psed23010@aegean.gr](mailto:psed23010@aegean.gr)

obstacles) or with the evolutionary arguments (e.g. the recapitulation argument that one's mind must go through the same stages that mathematics has gone during its evolution). On the other hand, the second category –that refers to history as a goal- is mainly connected with the learning of the history of mathematics as a purpose in itself. In the latter case, the basic purpose is to show to students the developmental aspects of mathematics as a discipline, meaning that mathematics exists with different forms in time and space and that its evolution is influenced by many different cultures. However, these two functions of the use of history during the learning of a mathematical concept or process are not always distinct and it is a matter of interpretation for someone to decide which function to support in a research program (Jankvist, 2009).

The effort for a creative development of the history of mathematics, during the teaching of this specific subject, is directly connected with views that have been expressed over the last decades about the nature of school mathematics, their learning and teaching. First of all, the view according to which school mathematics is a group of predetermined rules and techniques that have to be transmitted by the teacher to the pupils, has been replaced by the notion that mathematics must be experienced by the students as a socially constructed human activity. According to Freudenthal (1973) mathematics is a human activity and it is best learned by doing it. Students' shaping such beliefs agrees with the historical evolution of mathematics. Moreover, constructivist or socio-cultural theories have led to the modulation of a new frame for the learning and teaching of school mathematics (cf. NCTM, 2000). All mathematics educators agree today that children are capable of constructing their own mathematical meanings during the solution of their own problems. These problems stem from their own personal engagement with mathematical activities and their communication with the other members of the classroom. The construction of suitable mathematical activities, which offer the pupils the opportunity to develop a creative thinking within the classroom, constitutes a basic concern for those who are involved with didactics of mathematics. Towards this direction the design of effective educational material for mathematics can be connected with the history of mathematics in various ways. For example, an attempt is imprinted on the way that the history of mathematics is presented in the so-called realistic mathematics, one of the axes of this approach being the didactic phenomenology of Freudenthal (1973). According to this axis the students could follow the learning route that humankind has followed. That does not necessarily mean that during teaching, the historic evolution of a concept will be exactly reproduced, but the phenomena through which the mathematical concepts became meaningful could be an integral part of supporting the learning process about them. So, the researcher/designer may look at the history of mathematics as a source of inspiration (Gravemeijer, 2004).

However, as it was previously mentioned, whether history of mathematics “is appropriate, or even relevant at all to the teaching and/or learning of mathematics, is an issue that, despite the extended research and the many insightful and sophisticated applications in the last few decades, has not reached universal acceptance even today” (Clark et al., 2016). Moreover, it seems that there still exists a need for the evaluation of effective ways of the integration of history of maths in mathematics

education in order to deal with the gap between academic research and teaching practice (Wang et al., 2018). Furthermore, a lot of research has been done in higher secondary education and there is less work in lower levels of education.

This chapter presents examples for the design, implementation and assessment of mathematical activities based on history of mathematics during the teaching of school mathematics in primary and low secondary education. Our main concern is the investigation of learning opportunities that such activities could provide for the students concerning history as a goal and/or history as a tool. We present examples of worksheets describing the different ways of approaching a mathematical issue in various cultures from the history of mathematics, through the smallest module approach that concerns materials focused on a concrete topic of the curriculum, suitable for a few lessons in the classroom (Jankvist, 2009). The empirical evidence comes from a third class of junior high school as well as from a fourth grade of a primary school. In the first case two worksheets were given to the students, which presented the relation of Babylonians and Al-Khwarizmi with the solution of a quadratic equation. The students were acquainted with many historical facts, got involved in the process of studying and solving quadratic equations in the way Babylonians and Al-Khwarizmi used to and distinguished the similarities and differences between these two methods, but also between these methods and the contemporary one they had already been taught. In the second case the students were engaged in activities connected with the Babylonian and ancient Egyptian symbols about numbers and made comparisons between them and the modern symbols.

## **Why and How Use History of Mathematics in Mathematics Education**

The main arguments developed by many researchers proposing the integration of the history of mathematics into the curriculum of school mathematics are the following (see for example Fauvel, 1991; Tzanakis et al., 2000):

- (a) It can help to “humanize” and “demystify” the mathematical science, as it enables students to realize that school mathematics is not a set of “magic” rules, but a product of human activity developed according to the needs of each society and that it is changing over time. For example, the development of a multicultural approach to the teaching of mathematics helps to achieve this goal and contributes to the realization of the crucial role of mathematics in the development of society.
- (b) It can give students the opportunity to better understand the mathematical concepts they are dealing with and to realize the value of modern techniques and processes, through their involvement in situations of historical research and reflection around a mathematical topic.
- (c) It can facilitate the development of students’ positive dispositions towards mathematics, as it enables them to feel that difficulties and problems are an

integral part of the process of constructing new knowledge. They could realize that “mathematics- in -the making” is different from “mathematics- as- an- end product” (Siu & Siu, 1979, see p. 241 in Jankvist, 2009), as the creation of a mathematical concept is a result of many, continuous and persistent efforts, which many times were lasting for prolonged periods. In this way, they can better value their own efforts during their involvement with various mathematical problems.

- (d) It can contribute to the development of interdisciplinary activities and therefore the connection of mathematics with other cognitive subjects like philosophy, arts or sciences.

Moreover, up to now, the research that has been carried out for the integration of the history of mathematics in school mathematics curriculum, seems to be built around two fundamental axes:

- The use of primary (original) and/or secondary sources from the history of mathematics: The first axe includes the so-called “illuminations” and “module” approaches (Jankvist, 2009). In the illumination approaches, the teaching and learning of mathematics is supplemented by historical information, which may cover names, dates, biographies, famous problems etc. The module approaches are instructional units devoted to history that may differ in size and scope and they are often based on specific mathematical content.
- The organization of the teaching of a mathematical concept in a way that the historical route of its development is taken into account (a history-based or genetic approach). In this case, the important steps in the historical development of a mathematical topic must be identified (Tzanakis et al., 2000).

In both cases, a lot of discussions have been recorded. For example, the use of historical sources has provoked many debates on the ways that they could be used in parallel with the standard mathematics curriculum. Fried (2001) has proposed the method that he named “radical separation” for the incorporation of primary sources of the history of mathematics in mathematics education. He has argued that in order to help students to engage in a meaningful study of the history of mathematics, one must put the history of mathematics on a different truck from the regular course of study using primary resources. Someone could acknowledge that in order to humanize mathematics “one must look at it through the eyes and works of its practitioners with all their idiosyncrasies; one must, as far as possible, read their text as they wrote them” (see p. 401 in Fried, 2001). On the other hand, in the second axe there were a lot of discussions concerning to what extent the difficulties that pupils meet during the construction of a mathematical concept could be similar to those of mathematicians as they are historically recorded (epistemological obstacles), so that mathematics teaching could be organized in such a way that the historical conditions of creation and surpassing of those difficulties within the classroom can be reproduced. Some researchers supported the idea that such thing is not feasible, as today’s classroom differs substantially from the one of the past and the appearance and

surpassing of authentic epistemological obstacles is connected to a specific historic-sociocultural environment (Fauvel & van Maanen, 2000).

In this chapter we present examples with the use of secondary sources from the history of mathematics through the smallest module approach, adopting a multicultural approach to the teaching of mathematics.

### *Categories of Historical Texts*

The texts based on the history of mathematics that are usually proposed to be used in mathematics education could be classified in three categories as follows:

- Texts referring to problems that have been manifested by mathematicians during the development of a mathematical concept

This first category includes historical mathematical texts that imprint the difficulties of the mathematicians in the comprehension of a mathematical concept, the difficulties in understanding the way in which various mathematical concepts are connected, or the speculation about the nature and the methodology of mathematical activity (e.g. Kline, 1964). The presentation and discussion of those texts among the members of a classroom may help the deeper understanding of a mathematical concept or process, as a teacher can ask questions “about the author and the kind of activity she/he is engaged in, search for the hidden assumptions behind the terms the author uses, try and uncover the author’s understanding of the object she/he studies and how her/his understanding may differ from ours”, so that the students acquire a sense of the author’s intellectual environment (see p. 403 in Fried, 2001). Furthermore, the presentation of the dilemmas and doubts that known mathematicians had confronted, humanizes the mathematical science and helps pupils create views about mathematics that agree with the aims that the mathematics educators set today.

- Texts describing the different ways of approaching of a mathematical issue in various cultures

The second category includes historical texts, which set off the ways that different cultures envisaged various mathematical concepts and processes. The history of mathematics is a rich source for finding texts referring to various cultures, concerning issues of primary or secondary education, such as the different number systems, operations with natural or rational numbers, methods of solution of algebraic or geometrical problems etc. (e.g. Menninger, 1992). For example, the way that the Ancient Egyptians were executing the multiplication of integers could be used educationally towards this direction. The discussion of this topic within a classroom offers pupils the possibility to study the similarities and the differences between the current algorithm of multiplication and the process that was used by Ancient Egyptians. In doing so, not only do they learn different ways of computing but they also have a chance to reflect upon their own mathematical activity, probing deeply into the understanding of the specific process. Moreover, such kind of



activities help students realize that different cultures have contributed to the evolution of mathematical science, and recognize their own culture's contribution. As D'Ambrosio (1985) has reported: "Making a bridge among anthropologists and historians of culture and mathematicians is an important step towards recognizing that different modes of thoughts may lead to different forms of mathematics" (p. 44).

- Texts referring to the history of mathematics

Finally, the third category includes texts that delineate ways in which children were involved in mathematics in the past. Arcavi and Bruckheimer (2000) put the following problem to children aged 12–13: "If you had been born 60 years ago how could you have learnt arithmetic?". As they reported, the students' occupation with the particular question offered them the chance to think about the aims of mathematical education the last century. Towards this direction old mathematics textbooks from a country or even from different countries could be used as a fruitful resource.

Concerning all these texts, it could be stressed that in the study of historical mathematical texts, someone should be engaged in solving problems as well as in a kind of reflective thinking or inquiry in order to become deeply acquainted with the human activity of mathematical work. The meaningful study of the history of mathematics could give the opportunity to the students to feel the excitement and surprise in finding different solutions to known problems. Towards this effort research results indicate that the appropriate choice and presentation of sources from the history of mathematics have positive effects on students' learning (see for example Lim & Chapman, 2015).

## Examples and Reflections from the Classroom

In Greece there are no activities in the school math textbooks for the creative use of the history of mathematics in students' learning. More specifically in primary education there isn't any kind of historical texts about mathematics. In low secondary education since 1987 there are pieces of historical information at the end of some chapters on different mathematical topics that the students can read. However, these informations are not connected with fruitful mathematical activities for the students. They could be characterised as speak or stamp, that is small texts without mathematics assignments in class (van den Bogaart-Agterberg et al., 2021).

This unit presents examples of worksheets for the integration of the history of mathematics into mathematics education. The texts used described the different ways of approaching of a mathematical issue in various cultures and they were designed from classroom teachers in collaboration with a mathematics education university teacher in an effort to actually engage students in different kinds of mathematical tasks.

## *The Case of Quadratic Equation*

The first research was realized in a third class of a junior high school, in order to investigate the learning opportunities offered to students through their engagement with the solution of a quadratic equation in the culture of Babylonians (2000 BC) and the way of Al-Khwarizmi (830 AD). The research took place on February 2018 with 59 students in a high school of the city of Rhodes in Greece (34 boys and 25 girls). The students were distributed alphabetically in three groups in their school and every lesson lasted two teaching hours for each group. Two worksheets were used, one for each teaching hour, related to the history of the quadratic equation using historical information from secondary resources. We studied the existence of differences in relation to the gender of the students and their performance in mathematics. The students' attainment was based on their grades in school mathematics according to their teacher during the first 4 months of the school year. According to the teacher's assessment 7 students had high performance in mathematics (that is grades 19–20 in our country), 24 students had medium performance (grades 15–18) and 28 students low performance (grades under 15). Before the students' engagement with these worksheets, they had been taught the solution of a quadratic equation during nine teaching hours, according to the math curriculum. The questions in each worksheet were completed individually from the students and their answers were our data. There were ten true-false questions and two open-ended questions (students had to express their views on issues raised).

### **The Content of the Worksheets**

In general, both worksheets had the following structure: (a) some historical information, (b) examples of the solution of a quadratic equation, (c) exercises for the students and (d) questions concerning the comparison and assessment of different methods. So, the students were required to act on the mathematics involved in the text (solving the equation like standard textbook exercises) as well as to do a meta-task, in order to reflect on the piece of historical information of mathematics (Chorlay, 2016).

More specifically, the content of the two worksheets were the following:

A. The first worksheet had the title: "The quadratic equation and the Babylonians" and it contained the following tasks:

1. Why did the Babylonians learn to solve quadratic equations?

Historical information from Katz (1997) was used like the following: *It really wasn't so important to solve the quadratic equations – there were a few real situations that required it. It was important for students to develop problem-solving skills in general, skills that would empower them to solve the problems that nation's leaders had to solve.*

2. How did the Babylonians solve the quadratic equation?

From 2000 BC the Babylonians could solve pairs of equations like  $x_1 + x_2 = p$  and  $x_1 \cdot x_2 = q$  which are equivalent to the quadratic equation  $x^2 + q = px$ . This pair was solved by a method which gave the two roots of the equation:

$$x_1, x_2 = \frac{p}{2} \pm \sqrt{\left(\frac{p}{2}\right)^2 - q}$$

when both were positive (the Babylonians did not know the negative numbers).

The steps of the process were the following:

1. Form  $\frac{x_1+x_2}{2} = \frac{p}{2}$
2. Form  $\left(\frac{x_1+x_2}{2}\right)^2$
3. Form  $\left(\frac{x_1+x_2}{2}\right)^2 - x_1 \cdot x_2$
4. Form  $\sqrt{\left(\frac{x_1+x_2}{2}\right)^2 - x_1 \cdot x_2}$
5. Find  $x_1, x_2$  controlling the roots of steps 1 and 4

Of course these steps were not expressed in symbols, but were only applied with specific numbers (Stillwell, 1989).

3. Solving with the way used by Babylonians the equation:  $x^2 + 24 = 10x$   
Pose

$$q = x_1 \cdot x_2 = 24$$

$$p = x_1 + x_2 = 10$$

$$\text{Form } \frac{x_1+x_2}{2} = \frac{p}{2} = \frac{10}{2} = 5$$

$$\text{Form } \left(\frac{x_1+x_2}{2}\right)^2 = 5^2 = 25$$

$$\text{Form } \left(\frac{x_1+x_2}{2}\right)^2 - x_1 \cdot x_2 = 25 - 24 = 1$$

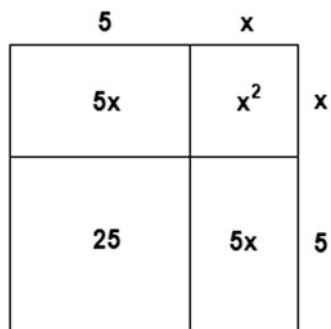
$$\text{Form } \sqrt{\left(\frac{x_1+x_2}{2}\right)^2 - x_1 \cdot x_2} = \sqrt{1} = 1$$

Thus  $x_{1, 2} = 5 \pm 1$ , so  $x_1 = 6$  and  $x_2 = 4$

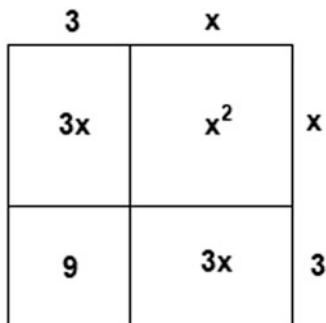
4. Using the above method in order to solve the equation  $x^2 + 12 = 8x$
5. Solve the same equation  $x^2 + 12 = 8x$  with the modern formula.
6. Mark the following sentences with T if they are True or with F if they are False:
  1. There is no similarity between the two ways of solving the quadratic equation.
  2. There are two solutions to the way of solving used by the Babylonians, as in the one with the modern formula.
  3. Both ways can separate the two solutions with the help of  $\pm$  signs.
  4. The Babylonians use a discriminant.

5. The quadratic equation in the Babylonians places the first degree term in the second part of the equation, while in the modern formula all terms must be in the first part in order to apply the way of solving it.
  6. The Babylonians use the sum and product of solutions without knowing them at first, while with the modern formula something like that does not happen.
  7. The Babylonians accept negative solutions, just as it is the case with the modern formula.
  8. The fixed term and the coefficient of the first degree term are necessarily positive numbers for the Babylonians, while with the modern formula they can also be negative.
  9. The Babylonians do not use symbols but only concrete numbers, as opposed to the modern formula which uses together numbers and symbols.
  10. The Babylonians solve quadratic equations in which the coefficient of  $x^2$  can take any value.
- B. The second worksheet had the title: “The quadratic equation and Al-Khwarizmi” and it contained the following tasks:
1. (a) Where do the words “algebra” and “algorithm” come from?  
 Historical information was used from Stillwell (1989) and the book “The parrot’s theorem” of Denis Guedj (1999).
  - (b) Who was Al-Khwarizmi?  
 Historical information was used from Swetz (1994) and Katz (1997).
  2. How did Al-Khwarizmi solve quadratic equation? (Fig. 6.1)  
 In order to solve the equation  $x^2 + 10x = 39$  he represents  $x^2$  with a square of side  $x$  and  $10x$  with two rectangles with sides 5 and  $x$ . The square for the number 25 completes the square with side  $x + 5$  to this with value  $25 + 39$  as  $x^2 + 10x = 39$ . So the big square is 64 and its side is  $x + 5 = 8$ . Thus the solution is  $x = 3$ . Euclid and Al-Khwarizmi did not accept the negative lengths, so the root  $x = -13$  of the equation  $x^2 + 10x = 39$  doesn’t appear. This is natural as geometry accepts only one square with area 64 (Stillwell, 1989).
  3. Using the above method in order to solve the equation  $x^2 + 6x = 40$  (Fig. 6.2).

**Fig. 6.1** Al-Khwarizmi’s solution of the equation  $x^2 + 10x = 39$



**Fig. 6.2** Al-Khwarizmi's solution of the equation  $x^2+6x=40$



**Table 6.1** Students' answers to the solution of the quadratic equation  $x^2 + 12 = 8x$

Students' answers	Tasks	
	$x^2 + 12 = 8x$ with the Babylonian method	$x^2 + 12 = 8x$ in the modern way
Correct	56% (33)	35.6% (21)
Partially Correct	18.6% (11)	18.6% (11)
Wrong	18.6% (11)	32.2% (19)
No answer	6.8% (4)	13.6% (8)

We represent  $x^2$  with a square of side  $x$  and  $6x$  with two rectangles with sides  $3$  and  $x$ . The square for the number  $9$  completes the square with side to this with value  $9 + 40$  as  $x^2 + 6x = 40$ . So, the big square is  $64$  and its side is  $x + 3 = 7$ . Thus the solution is  $x = 4$ .

4. What similarities and differences do you notice between the way of Al-Khwarizmi and the modern formula that we use today?
5. What did you like about the two different ways of solving the quadratic equation, the Babylonian way and that of Al-Khwarizmi?

### Evaluating the Worksheets

According to the design of the worksheets we could mention that the first one concerned mainly the history as a tool (for assisting the actual learning and teaching of the quadratic equation) and the second one mainly the history as a goal. In Table 6.1 the students' answers to the solution of the quadratic equation  $x^2 + 12 = 8x$  with the Babylonian method and in the modern way are presented. Then the children's answers are analyzed according to their performance in mathematics and their gender (see Tables 6.2 and 6.3).

The students' answers were categorized as correct, partially correct and wrong. For example, if a student had realized at least three steps correctly with the Babylonian method and then he/she stopped or he/she made mistakes, his/her answer was characterized as partially correct (e.g.  $x_1 \cdot x_2 = 12$  and  $x_1 + x_2 = 8$ ,  $\frac{x_1+x_2}{2} = 4$ ,  $(\frac{x_1+x_2}{2})^2 = 4^2 = 16$ ,  $16 - 12 = 4$ ,  $\sqrt{16-8} = \sqrt{8}$ ,  $x_{1,2} = 4 \pm \sqrt{8}$ ).

**Table 6.2** Students' answers depending on their performance

Students' answers	the Babylonian method			the modern way		
	HP (7)	MP (24)	LP (28)	HP (7)	MP (24)	LP (28)
Correct	100% (7)	54% (13)	46% (13)	86% (6)	37.5% (9)	18% (5)
Partially Correct	0% (0)	21% (5)	21.5% (6)	14% (1)	25% (6)	14% (4)
Wrong	0% (0)	21% (5)	21.5% (6)	0% (0)	37.5% (9)	43% (12)
No answer	0% (0)	4% (1)	11% (3)	0% (0)	0% (0)	25% (7)

*HP* high performance, *MP* medium performance, *LP* Low Performance

**Table 6.3** Students' answers depending on their gender

Students' answers	the Babylonian method		the modern way	
	Girls (25)	Boys (34)	Girls (25)	Boys (34)
Correct	64% (16)	50% (17)	40% (10)	30% (10)
Partially Correct	24% (6)	15% (5)	8% (2)	26% (9)
Wrong	12% (3)	23% (8)	48% (12)	26% (9)
No answer	0% (0)	12% (4)	4% (1)	18% (6)

When a student had realized only one or two steps and then he/she stopped or he/she made mistakes, it was characterized as wrong (e.g.  $x_1 \cdot x_2 = 12$  and  $x_1 + x_2 = 8$ ,  $\frac{x_1+x_2}{2} = 4$ ,  $\left(\frac{x_1+x_2}{2}\right)^2 = 8^2 = 64$ ,  $64 - 24 = 40$ , etc.). Analogous categorization was used for the solution of the equation with the modern way. When the students used the correct formula and made errors in calculations, their answers were characterized as partially correct. If they used a wrong formula, their answers were characterized as wrong.

Although the students came into contact with such an approach to the solution of the quadratic equation with the Babylonian method for the first time, 56% were able to solve the equation correctly, in contrast to the modern way where only 35.6% of them solved it correctly. A possible interpretation for this result is that the Babylonian algorithm is executed with the help of simple operations, in contrast to the modern formula which requires knowledge of the algebraic language. Moreover, these differences in the number of students who correctly solved the equation with the Babylonian method in relation to those who solved it correctly in the modern way were due to the medium (24 students) and mainly low-achieving students (28 students) in mathematics (see Table 6.2).

According to the above results, 54% of the students of medium performance in mathematics correctly solved the equation with the Babylonian method and 37.5% in the modern way. Moreover, 46% of the students of low performance in mathematics correctly solved the equation with the Babylonian method and 18% in the modern way. These results show that the engagement of medium and low achievement students with the different ways of solving an equation helped them to perform well in mathematics and this fact could constitute a positive experience for them during their mathematics education.

**Table 6.4** Students' right answers in the true-false questions

Question	Students' right answers
1	66.1% (39)
2	54.2% (32)
3	83.1% (49)
4	79.7% (47)
5	52.5% (31)
6	54.2% (32)
7	72.9% (43)
8	71.2% (42)
9	50.8% (30)
10	59.3% (35)

Table 6.3 shows that the girls did better than the boys in solving the equation with the Babylonian method (if we add correct and partially correct answers), while in the modern way the percentages seem to be divided between boys and girls (a little better for the boys). We consider that this fact also could be a positive experience for the girls about their mathematics education, if we take into account that in these ages there is a difference between girls and boys concerning their beliefs about math (Bevan, 2001; Forgasz, 1998; Leder, 1992)

Finally, Table 6.4 presents the relative and the absolute frequencies of the students' right answers in the true-false questions in the first worksheet.

More than half of the students, after processing the first worksheet and combining the knowledge they had gained from solving the quadratic equation based on the textbooks, found that the way the Babylonians used to solve the equation had many similarities to the modern type, although the Babylonians did not use symbols but specific numbers. In addition, the large formulas with square roots and the various variables presented to explain the Babylonian way do not seem to have prevented students from recognizing common features in the modern way. We posit that the structure of the worksheet -as they have solved the same equation with both ways- helped them to answer correctly in these questions.

For the second worksheet, concerning the question what they liked about the two different ways of solving the quadratic equation, it was interesting that the students' comments had a cognitive base, that is they focused on the facility or difficulty of these methods as well as some characteristics of each method. More specifically, most students (25.4%, 15 students) expressed themselves positively in the convenience of one or the other type of solution. Some illustrative examples are the following:

*I did not like the way the Babylonians used, because it seemed more difficult to me. I liked the way Al-Khwarizmi is, because it is easier and geometric, also because it has areas and you calculate differently than in our formula where you just replace and solve.*

*In my opinion, the way the Babylonians solved the quadratic equations was as effective as that of Al-Khwarizmi, but it was an easier way for the Babylonians.*

*I liked the Babylonians' solution more, because it has more in common with the modern way and that is why it is easier. I did not like Al-Khwarizmi's way, because I find it more difficult to combine geometry.*

*I like that both ways did not use negative numbers.*

Some students (mentioned only the characteristic elements of Al-Khwarizmi's way (20.3%, 12 students) or they mentioned only the characteristic elements of the Babylonian method (16.9%, 10 students):

*Al-Khwarizmi:*

*It combines the Science of Algebra with the Science of Geometry for the solution of the quadratic equation.*

*I find interesting in the Al-Khwarizmi formula the idea of using geometry (area) to solve an exercise in Algebra.*

*The Babylonian method:*

*I really liked the way the Babylonians used  $p$  and  $q$ , even though it was a bit difficult to express it.*

*In the way of the Babylonians there was a structure and a series of orders and if one learned them one could solve the equation.*

However, there were also 7 students (11.9%) that they did not like anything in the two ways of solving the quadratic equation and 6 students (10.2%) did not answer the question at all.

## ***The Case of Numbers Systems***

In primary education three one-hour lessons about ancient number systems took place in a class of fourth grade students (10 years old) in 2009. The students were introduced to a scenario where two friends of 10 years old, named Pythagoras and Hypatia, have learnt that their names were names of well-known mathematicians of Ancient Greece and began to search and gather information on the mathematics of ancient times. The students were engaged in activities concerning the investigation of how the Babylonians wrote their numbers, to recognize numbers using the Babylonian symbols and to compare the number system we use today with that of the Babylonians. Then, they studied the number system of ancient Egyptians, they tried to make additions with Egyptian and modern symbols and to make comparisons between them. They also studied the way the Egyptians multiplied. We present two episodes from the classroom concerning the learning opportunities that these activities offered to the students using history as a tool.

### ***Episode 1***

The first activity that they discussed was the following: Pythagoras and Hypatia, looking for various books on mathematics of the Ancient Babylonians and the Ancient Greeks, found an image that showed a Babylonian number and an ancient Greek one. Below the image was the note: Both symbols mean the same number. The students tried to find out what the number was (Fig. 6.3).



**Fig. 6.3** A number in ancient Greek and in Babylonian



The students concluded that the symbols  $\iota$  and  $\beta$  represent the numbers 10 and 2 respectively, based on their experiences from everyday life in Greece (for example the greek symbols are used in solving crossword puzzles or in numbering the classrooms). Then the following discussion took place:

*John: Since  $\iota$  is 10 and  $\beta$  is 2, the number will be 102.*

*Teacher: Do you agree;*

*Ann, Helen: Yes, 102.*

*Menios: No. It's 12. 10 and 2, 12.*

*John: I do not agree with what Menios said, because Menios added the two numbers. Whereas, let's say, when we see a number and want to get out what the number is, we do not add, we read.*

*Teacher: Menio, what do you have to say to him? He tells you that you did not do well, because you added the two numbers.*

*Menios: 12 is made from 10 and 2. If we find that this 1 means 10 and the other is 2, of course it is 12.*

*Antonis: It's 102. As we said  $\iota$  is the tenth number, I made it hundreds, I added  $\beta$  and I made it 102.*

*Teacher: What do you say to the idea of Antonis?*

*Irene: Why did you do it hundreds?*

*John: Menios is right. Yes, Menios is right. To get 25, we add 20 and 5.*

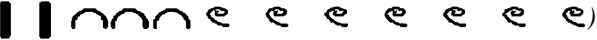
In this episode as the students tried to determine the value of a number, they managed to apply the multiplication principle and the addition that we use in order to analyze a number in the decimal number system and they arrived at the solution of the problem. That is, they intuitively understood that the way to write a two-digit natural number  $\alpha$  in the decimal system is based on the following principle:

$$\alpha = x_2x_1 = x_2 \cdot 10 + x_1$$

### **Episode 2**

As the students engaged in activities related to the execution of operations in different number systems, they compared the way in which the ancient Egyptians calculated sums with the modern process of addition they had been taught. The following episode is representative of the discussions that took place in the classroom. The children tried to calculate the sum  $679 + 53$ , using firstly the symbols of ancient Egyptians and then they performed the standard addition algorithm (Fig. 6.4).

*Spyros: 9 and 3, 12. I am writing 2 lines and a ten (with Egyptian symbols). Then I have 5 and 7, 12 and a ten that I had before 13. I am writing two more tens and a hundred. And six more hundred, 7 hundred. I found 732.*

(He wrote )

Teacher: When did you have to form groups and write a new symbol?

Spyros: With the units and the tens.

Teacher: Fine. Here we collected 10 units, and we made a ten and here we collected 10 tens and we made a hundred (he shows the corresponding actions in the table). You can do the addition now in our own way.

Spyros: 3 and 9, 12. I am writing 2, 1 to be carried over. 5 and 7, 12, and 1 to be carried over 13. I am writing 3, and 1 to be carried over. 6 and 1, 7. 732.

Teacher: What do these to be carried over show? The first one to be carried over?

Spyros: Ten.

Teacher: The other one to be carried over?

Spyros: Tens again

Teacher: Does anyone have a different opinion?

Antonis: Yes. I think that this is hundreds.

Teacher: Ok. What would you say to Spyros to change his mind?





















1		20	
2		30	
3		40	
4		50	
5		60	
6		70	
7		80	
8		90	
9		100	
10		1000	

Fig. 6.4 Egyptian symbols

*Antonis: We give this to the hundreds, we do not give it to the tens. If it was ten and we added it to the hundreds it would be 610, not 700. It's like in Egypt, we have 7 hundred (he shows the symbols of the hundreds).*

In the second episode the students had the opportunity to develop arguments about what the number to be carried over symbolized each time. This discussion was very fruitful, as they could overcome their misconceptions about the number to be carried over. The understanding of the value of the number to be carried over is one of the main difficulties that students have with the execution of addition at this age.

## Reflections

In this chapter we presented examples for the design, implementation and assessment of mathematical activities based on the history of mathematics during the teaching of school mathematics in primary and low secondary education. The mathematical topics that we used in both cases were fully compatible with the content of the Greek math curriculum. However, the students neither in the high school nor in the primary education had until then the opportunity to discuss topics concerning the history of mathematics. Our purpose was to investigate if these texts could enrich the mathematical experience of the students. Concerning the design, implementation and assessment of the tasks, we could mention that both teachers and students reported positively about the educational value of the history of mathematics in the classroom. So, the educational effects of these experiences were positive on the students' engagement with mathematics.

In the first case of the quadratic equation in a 3rd class in a high school, according to the results, the majority of the students – even students with low performance- managed to solve accurately the quadratic equation using the method of Babylonians. Moreover, when students were required to do the meta-tasks, most of them gave correct answers (true-false questions). Chorlay (2016) has mentioned that in that case, the identification of the relevant mathematical background knowledge of the students -in order to successfully perform a meta-task concerning history of mathematics- plays an important role, as students have to answer on the basis of the math they have already learnt and to act as experts endowed with background knowledge. This is a point of further investigation regarding the structure a worksheet using historical texts and the conditions for its success.

In the second case of primary school, the students also had genuine reflective opportunities to discuss on issues concerning their actual knowledge about the structure of numbers and algorithms. As they tried to interpret and justify the use of ancient symbols, they managed to overcome their own misconceptions about the modern way of executing algorithms. In our opinion this reflective process on their already existing knowledge converted history as a powerful tool of learning mathematics.

According to D'Ambrosio (2007) teaching mathematics of other cultures like the mathematics of ancient Egypt or the mathematics of the Mayas etc. is to demystify

mathematics as being “final, permanent, absolute, unique” and to overcome the conception “that those who perform well in mathematics are more intelligent, indeed “superior” to others and to illustrate intellectual achievement of various civilizations, cultures, peoples, professions, gender” (see p. 295 in Jablonka & Gellert, 2012). However, the above examples show that history of math can play a more essential role in the teaching of mathematics, as it offers a lot of learning opportunities for the students. The students can engage in genuine discussions and challenging situations concerning their own mathematical knowledge overcoming misconceptions and obstacles that they had. Moreover, these mathematical learning opportunities could help them feel good and help shape positive attitudes towards this subject.

In our opinion the investigation of designing tasks concerning history of mathematics in different ages is an open research question. One issue concerns the selection of suitable historical content that it could be used. Another issue concerns the degree of students’ engagement in each task. Moreover, as teacher’s training in designing activities based on the history of mathematics is a necessary step towards the fruitful use of the history in math education, more research is also needed towards this direction. Finally, the implementation of the proposed tasks in real math classrooms and their assessment both from a cognitive and affective point of view is necessary.

## References

- Arcavi, A., & Bruckheimer, M. (2000). Didactical uses of primary sources from the history of mathematics. *Themes in Education, 1*, 55–74.
- Bevan, R. (2001). Boys, girls and mathematics: Beginning to learn from the gender debate. *Mathematics in School, 30*(4), 2–6.
- Chorlay, R. (2016). Historical sources in the classroom and their educational effects. In L. Radford, F. Furinghetti, & T. Hausberger (Eds.), *Proceedings of the 2016 ICME satellite meeting of the international study group on the relations between the history and pedagogy of mathematics* (pp. 5–24). IREM de Montpellier.
- Clark, K., Kjeldsen, T. H., Schorcht, S., Tzanakis, C., & Wang, X. (2016). *History of mathematics in mathematics education: Recent developments* (pp. 1–42). [https://www.academia.edu/26341958/History\\_of\\_Mathematics\\_in\\_Mathematics\\_Education:\\_Recent\\_developments](https://www.academia.edu/26341958/History_of_Mathematics_in_Mathematics_Education:_Recent_developments)
- D’Ambrosio, U. (1985). Ethnomathematics and its place in the history and pedagogy of mathematics. *For the Learning of Mathematics, 5*(1), 44–48.
- D’Ambrosio, U. (2007). Peace, social justice and ethnomathematics. In B. Sriraman (Ed.), *International perspectives in social justice in mathematics education* (Monograph of the Montana Enthusiast) (pp. 25–34). The University of Montana and the Montana Council of Teachers of Mathematics.
- Fauvel, J. (1991). Using history in mathematics education. *For the Learning of Mathematics, 11*(2), 3–6.
- Fauvel, J., & van Maanen, J. (2000). *History in mathematics education. The ICMI study*. Kluwer Academic Publishers.
- Forgasz, H. (1998). The “male domain” of high school and tertiary mathematics learning environments. In C. Keitel (Ed.), *Social justice and mathematics education: Gender, class, ethnicity and the politics of schooling* (pp. 32–44). International Organization of Women and Mathematics Education.

- Freudenthal, H. (1973). *Mathematics as an educational task*. Reidel.
- Fried, M. (2001). Can mathematics education and history of mathematics coexist? *Science & Education*, 10, 391–408.
- Gravemeijer, K. P. E. (2004). Creating opportunities for students to reinvent mathematics. In *Regular lecture at the 10th international congress on mathematical education (ICME 10)*.
- Guedj, D. (1999). *The parrot's theorem*. Polis.
- Jablonka, E., & Gellert, U. (2012). Potentials, pitfalls and discriminations: Curriculum conceptions revisited. In O. Skovsmose & B. Geer (Eds.), *Opening the cage: Critique and politics of mathematics education* (pp. 287–307). Sense Publishers.
- Jankvist, U. T. (2009). A categorization of the “whys” and “hows” of using history in mathematics education. *Educational Studies in Mathematics*, 71, 235–261.
- Jankvist, U. T. (2010). An empirical study of using history as a ‘goal’. *Educational Studies in Mathematics*, 74, 53–74.
- Katz, V. J. (1997). Algebra and its teaching: An historical survey. *Journal of Mathematical Behavior*, 16(1), 25–38.
- Kline, M. (1964). *Mathematics in western culture*. Oxford University Press.
- Leder, G. (1992). Mathematics and gender: Changing perspectives. In D. A. Grouws (Ed.), *Handbook of research in mathematics teaching and learning* (pp. 597–622). Macmillan.
- Lim, S. Y., & Chapman, E. (2015). Effects of using history as a tool to teach mathematics on students’ attitudes, anxiety, motivation and achievement in grade 11 classrooms. *Educational Studies in Mathematics*, 90, 189–212.
- Menninger, K. (1992). *Number words and number symbols*. Dover Publications.
- National Council of Teachers of Mathematics (NCTM). (2000). *Principles and standards for school mathematics*. NCTM.
- Siu, F.-K., & Siu, M.-K. (1979). History of mathematics and its relation to mathematical education. *International Journal of Mathematical Education in Science and Technology*, 10(4), 561–567.
- Stillwell, J. (1989). *Mathematics and its history*. Springer.
- Swetz, F. J. (1994). *From five fingers to infinity*. Open Court.
- Tzanakis, C., Arcavi, A., Correia de Sa, C., Isoda, M., Lit, C.-K., Niss, M., Pitombeira de Carvalho, J., Rodriguez, M., & Siu, M.-K. (2000). Integrating history of mathematics in the classroom: An analytic survey. In J. Fauvel & J. van Maanen (Eds.), *History in mathematics education: The ICMI study* (pp. 201–240). Kluwer.
- van den Bogaart-Agterbeerg, D. A., Oostdam, R. J., & Janssen, F. J. J. M. (2021). From speck to story: Relating history of mathematics to the cognitive demand level of tasks. *Educational Studies in Mathematics*, 110, 49–64. <https://doi.org/10.1007/s10649-021-10093-6>
- Wang, K., Wang, X., Li, Y., & Rugh, M. (2018). A framework for integrating the history of mathematics into teaching in Shanghai. *Educational Studies in Mathematics*, 98, 135–155.

# Chapter 7

## Re-constructing the Image of Mathematics Through the Diversity of the Historical Journeys of Famous Mathematicians



Fragkiskos Kalavasis and Andreas Moutsios-Rentzos

**Abstract** In this chapter, we discuss a teacher training programme with pre-service pre-school and primary school teachers (PSTs) in Greece. The programme attempts to facilitate the PSTs' re-visiting their usually negative affective with mathematics and with teaching mathematics, in order to support their actively re-constructing a positive and functional image of mathematics. Through this program, the PSTs are involved in more accessible to them research practice and mathematical activity to understand the variety of historical backgrounds of mathematicians in different eras and regions, so to recognize and to encourage variety in didactical situations. We therefore employ a systemic and interdisciplinary perspective of mathematics, with the aim of giving PST the epistemological means to reconstruct their image for mathematics and to create mathematical knowledge with greater levels of positive affectivity and efficiency. Importantly, the history of mathematics is employed as means for acknowledging the seemingly paradoxical diversity and universality of mathematics, thus facilitating their developing inclusive pedagogical practices in their future careers. Along with the theoretical discussion of the programme, the design of two implementations of the programme are presented: a small-scale implementation (including less than 15 participants) and a large-scale implementation (including more than 100 participants). The implications of our approach with respect to research and practice are discussed.

**Keywords** Teacher training · History of mathematics · Interdisciplinary curriculum · Inclusive education

---

F. Kalavasis

Department of Pre-School Education Sciences and Educational Design, University of the Aegean, Rhodes, Greece

e-mail: [kalabas@aegean.gr](mailto:kalabas@aegean.gr)

A. Moutsios-Rentzos (✉)

Department of Pedagogy and Primary Education, National and Kapodistrian University of Athens, Athens, Greece

e-mail: [moutsiosrent@primedu.uoa.gr](mailto:moutsiosrent@primedu.uoa.gr)

## Introduction

Mathematics is at the crux of the modern curricula, as identified by their qualitative characteristics, the amount of educational time devoted to the teaching and learning mathematics, and by the fact that being successful in mathematics is often considered as a strong index of success of the whole educational system. The ability of students to recognize, connect and apply mathematical models within mathematics (e.g. geometric and algebraic reasoning) and beyond mathematics (e.g. interdisciplinary, STE(A)M etc.) seems to be recognized internationally (EU, UNESCO, OECD) as a crucial educational aim, linked amongst others with twenty-first century skills and critical thinking (Ananiadou & Claro, 2009; Applebaum, 2015; Voogt & Roblin, 2012). At the same time, there has been a broader interest in education about the need for revisiting educational outcomes to include social and affective aspects, sometimes identified as ‘21st century subjects, themes and skills or competences’ (e.g. Voogt & Roblin, 2012), ‘soft skills’ (Heckman & Kautz, 2012) or ‘social and emotional learning’ (Jones & Doolittle, 2017; Pekrun & Linnenbrink-Garcia, 2014).

The technologically connected and expanded living present as identified in the contemporary school unit is radically transformed socio-culturally, temporally and geographically (Moutsios-Rentzos et al., 2017). The variety of the employed approaches and the multiplicity of perceptions and expressions are fundamental in this novel pedagogical hybrid reality. It is argued that the need for inclusive teaching practices (e.g. UNESCO, 2005; UNICEF, 2007), especially in mathematics, a course that has deep socio-cultural and political links, is more crucial than ever before in the human history. Moreover, these practices need to be epistemologically valid, as well as adaptable and mathematically accessible to the young learners. Within this complexity, the training of both in-service and pre-service teachers needs to address, for example, the interpretation and communication of scientific information through mathematical notation and ideas, as well as the handling of vast amount of information, which requires, amongst others, the relational understanding of mathematical ideas. Consequently, it is argued that, for this purpose, the teacher education programmes need to re-consider the mathematical ideas that are important for the students of different levels, as well as the multiplicity of relationships of mathematics with other courses and with everyday life. Hence, it is required a re-construction of the image of mathematics: *mathematics as a life-tool for all*. Such a radical re-positioning of essentially the whole educational system is hardly easy. It is posited that through a series of strategic engineering planifications aiming at systemic reflections, the educational system may reach a new equilibrium bearing (aspects of) the desired characteristics.

In particular, in this chapter, we focus on preservice preschool and primary school teachers (PSTs). Though the educational levels qualitatively differ and the training of the respective PSTs, these pre-service teachers share important characteristics: they are both institutionally identified as pedagogues, they both have to teach courses that are not considered to be experts (in this case mathematics). This training

programme is settled within a broader programme that aims to support the PSTs' reflectively re-constructing their image of mathematics. Such a re-construction of their usually, negative, uni-dimensional and procedural school mathematics experience is essential for their developing an appropriate mathematics teacher identity. Within the broader training programme, the PSTs follow a series of seminars and supervised work, in order to experience the complexity of the phenomenology of mathematics learning and teaching in school and to acquire the skills to organise and manage didactic situations. The corpus of the broader training programme was developed and produced in the two institutions for training PSTs: the National and Kapodistrian University of Athens (for primary school teachers) and University of the Aegean (for preschool teachers). The PSTs are taught courses that include didactics of mathematics (theories, activities, educational tools etc) and mathematics (set theory, number theory, geometry etc), We complement these courses with three lines of training:

- *an interdisciplinary and systemic approach to school mathematics*; focused on the emergence of the functional importance of the role of the family and its positioning with respect to the cultural, social and professional value of mathematics, as well as on the role of the school experience and its positioning about the links of mathematics with other disciplines and the various professions (see, for example, Moutsios-Rentzos et al., 2020; Moutsios-Rentzos & Kalavasis, 2016; Kasimatis et al., 2021).
- *a real-life approach of students' academic mathematical experiences*; through the production of digital narratives and a series of individual and collective reflections, we attempt to facilitate the emergence of the functional importance of the multifaceted emotional dimensions in the PSTs' mathematical teaching (and learning) journey, which crucially affects their mathematical (teaching/learning) identity (see, for example, Moutsios-Rentzos et al., 2019, 2022).
- *the anthropological and epistemological approach to the history of mathematics*; in order to for the PSTs to participatorily reconstruct their image of mathematics, by recognizing the diversity of the courses and the role of the cultural and social context in the elaboration of the concepts and writing mathematics, intellectual experiments and mathematical proofs, theories, applications and their interactions with the development of civilizations and their technologies.

In this chapter, we discuss the latter line of the broader training programme. At the crux of our approach lies the development of the *scientific method* as means: (a) for finding and evaluating information in the literature (scientific, historical etc) and/or through the collection of empirical data, and (b) for synthesizing, representing and appropriately reporting scientifically valid claims. It is argued that through subjecting the PSTs' interactions with historical and/or empirical information to the de-subjectified scientific scrutiny, the PSTs's experiences transcend the subjective and obtain a status of valid scientific knowledge. It is posited that such a transformation constitutes a factor that enables the PSTs to functionally re-construct their image of mathematics, which may act as a wholistic transformation factor with respect to their relationship with mathematics and with teaching mathematics.



## History of Mathematics and Mathematics Education

The history of mathematics has drawn the attention of mathematics educators, as means for facilitating the learners' efforts. Though the complexities of such endeavour are acknowledged (Radford, 1997), researchers have attempted to synthesise different paths that may be followed in order to appropriately employ history of mathematics in the classroom (Arcavi & Isoda, 2007; Boero, 2007; Clark et al., 2018; Fauvel, 1991; Fried, 2001; Furinghetti, 2020; Jankvist, 2009; Jankvist & Kjeldsen, 2011; Kjeldsen & Blomhøj, 2012). In particular, it has been argued that the history of mathematics enroots the learners' construction of mathematical ideas within the historical and sociocultural context of their introductions and their development, thus linking them with human needs and intentionalities (for an overview, see Barbin et al., 2020). In this way, the learners may conceptualise mathematics as relevant to the lifeworld of the learners and, importantly, as being strongly intertwined with the various strands of development of human civilization (about mathematics in general, but also about specific mathematical ideas as, for example, about the notion of mathematical proof or the Pythagorean theorem; Moutsios-Rentzos & Spyrou, 2015; Moutsios-Rentzos et al., 2014). Godelier (1977) noted that history transforms our relationship with Nature and our relationship with each other.

Following these, researchers stress that if we agree about the importance of including history of mathematics in the teaching and learning mathematics, then we should provide appropriately designed, relatively long-term, training to in-service and pre-service mathematics teachers (see, Barbin et al. 2015; Barbin et al., 2019; Fauvel & van Maanen, 2002; Furinghetti, 2007). For example, Guillemette (2017) in a study with secondary school teachers who were engaged in reading historical texts found that the

future teachers give themselves a new responsibility of welcoming their learners and their reasoning in a nonviolent way. The readings of historical texts can thus, among the preservice teachers, support and encourage this participative act that is the empathic movement towards the Other in the mathematics classroom, bringing open-mindedness to marginality, novelty and singularity (p. 362–363)

We consider such findings particularly encouraging and relevant to our assumption that history of mathematics may prove to be an important tool for designing inclusive mathematics education. Hence, in this study, we draw upon these to employ history of mathematics as means for facilitating the PSTs' reconstructing their cognitive and affective relationship with mathematics through a systemic, interdisciplinary approach.

## A Systemic, Interdisciplinary Approach to Teacher Training Though the History of Mathematics

Our approach is built upon a *systemic, interdisciplinary* approach to mathematics education (Moutsios-Rentzos & Kalavasis, 2016), according to which mathematics teaching and learning occurs through a continuous interplay with other courses and

real-life situations. The school unit is conceptualised as learning organisation; a complex whole “characterised by its developing systems thinking, personal mastery, mental models, team development and building a shared vision” (Kasimatis et al., 2021, p. 331). Following these, in our training approach history is utilised to facilitate the PSTs’ experiencing mathematics as being part of an interdisciplinary, complex whole. In other words, the PSTs are expected to reflect upon their experiences in a systemic way, in order for them to build a systemic, interdisciplinary conceptual network of learning mathematics as linking links (Moutsios-Rentzos & Kalavasis, 2016), thus expanding the well-known qualities of conceptual knowledge (Hiebert & Lefevre, 1986) or relational understanding (Skemp, 1976).

In this study, we draw upon research findings that emphasise “the necessity to read original texts, not in relation to our present knowledge and understanding but in the context they were written” (Barbin et al., 2020, p. 337). We agree that is important for the learners to become familiar with the context within which a mathematical idea is generated and becomes visible within the course of human civilisation. However, instead of putting the historical texts at the crux of our programme, we chose to focus on the *mathematicians* themselves; the protagonists, the historical figures who created those mathematical ideas, which subsequently were objectified by means of the written text. By turning the PSTs’ attention to the person who produces mathematics, rather than the product itself, we allow for the context to obtain the complexity that we as socio-cultural beings face –and constitute– in our lived present.

The mathematician as a historical figure followed a multidimensional path that transcends mathematics; for example, other scientific disciplines, engineering, economics, politics, disabilities, gender, religion, race, social class are just a few of the aspects that the PSTs may discover about the path of the historical figure. At the same time, the PSTs relate and situate the mathematical ideas with the historical context and draw parallels with the present context they experience each day. Through this approach the PSTs re-visit mathematics within the various systems it constitutes: social systems and systems of scientific disciplines (Moutsios-Rentzos & Kalavasis, 2016). Moreover, the PSTs experience the variety and the connections among mathematicians and mathematics communities, in order to reinforce the background of the mathematical culture of the PSTs and to provide epistemological support to the pedagogical objective for inclusive teaching practices in mathematics education.

In line with similar approaches (Barbin et al., 2020), our approach employs history to address and support the PSTs’ positively re-constructing both their affective and cognitive relationship with mathematics. Considering the cognitive relationship with mathematics, during our training programme the PSTs are engaged with the mathematical problems posed, solved, or linked with the historical figure that is at the crux of their investigations. Moreover, they may become familiar with the mathematical tools and notation of the era, allowing them to realise that mathematics, being a deeply human activity, is under constant development and social negotiation. Hence, the PSTs may be asked to work with Platonic solids or with Euler’s Bridges of Königsberg and to reflect upon the importance of these tasks in

the science of mathematics, their links with other disciplines, their broader social effect, as well as their presence in their multifaceted lived present.

Considering their affective relationship, our training programme attempts to support the PSTs' re-construction of their *image of mathematics*, referring to a wholistic affective re-positioning towards mathematics. Ernest (1995, 2008) discussed the image of mathematics as a system of beliefs and views about mathematics. In a study about inclusive mathematics education (Pinnika et al., 2018), we built upon Ernest's ideas and upon a systemic perspective to affect (Pepin & Roesken-Winter, 2014) to propose a conceptualisation of the image of mathematics as an affective system, consisting of five components organised in three dimensions: (a) the *accumulated affect* (beliefs, values, and attitudes; Philipp, 2007; Seah et al., 2008), (b) the *real time affect* (emotions; Hannula, 2002), and (c) the *affective potential* (expectations; Betz & Hackett, 1983). These components and dimensions are diagrammatically organised in a trigonal bipyramid (Pinnika et al., 2018) as means for representing both the local relationships of the parts of the three dimensions and the wholistic nature of the construct. We argued that by employing this conceptualisation in investigation across the educational system, we obtain "multidimensional cross-mappings of the existing educational interactions and networks", thus "allowing for a pragmatic address of the call for inclusivity" (Pinnika et al., 2018, p. 262; original emphasis).

Furthermore, we acknowledge that, in Greece, both the pre-school and the primary school teachers share a difficult professional reality, which adds negative load to their affective and cognitive relationship with mathematics (Moutsios-Rentzos et al., 2022). They are expected to teach courses linked with diverse disciplines (mathematics, physics, language etc), while their professional and scientific identity is different: they are pedagogues, not mathematicians or physicists. The role of history is expected to challenge this dominant giving meaning processes, allowing for the PSTs to re-visit their own identities and re-position themselves with their future profession and their vision about teaching and teaching mathematics (Hammerness, 2001; Munter, 2014).

For this purpose, in our training programme the PSTs act as researchers, actively building a *scientific stance* to knowledge, through a series of *scientific research practices*. They learn, amongst others: to search for historical sources; to evaluate their findings and the findings of others; to present their findings; to reflect upon the feedback they receive; to compose a scientific report in line with the standards of the scientific community etc. We posit that the scientific stance *empowers* the PSTs to face mathematics and its power, as mathematics is subjected to scientific scrutiny, "defending" its value, rather than a priori being considered an omni-temporal truth; it *may* be useful, it *may* be fallible, it *may* be valued or disvalued. In other words, we argue that by providing the PSTs with scientific tools to investigate the lives of famous mathematicians, we allow them to actively re-story the history of mathematics, thus providing them with the opportunity to re-visit their relationship with mathematics.

Overall, in our teacher training approach the PSTs employ a scientific stance and scientific research practices to focus on mathematicians and their historical paths, in

order to emphasise the systemic, interdisciplinary perspective of mathematics, with the purpose for the PSTs to be empowered to re-construct their image of mathematics.

## **One Approach: Two Implementations**

These ideas were implemented in two training programmes: one small-scale implementation with pre-school PSTs (Pre-PSTs) and one large-scale implementation with primary school PSTs (Pri-PSTs).

### ***Small-Scale Implementation: The Research Team Working Paradigm***

Regarding the Pre-PSTs, the small-scale programme is now in its fourth iteration. We have worked with a three-year implementation with different groups of Pre-PSTs of our approach, as part of a university course entitled “Mathematical journeys of people and civilisations: planning by drawing upon the variety”.

The 13-week course is structured as a series of workshops, which includes both collaborative and individual work. The Pre-PSTs, organized in small groups (two to five members), form *research teams* with diverse roles for each member.

All the research teams communicate and are being co-ordinated by a *co-ordination team*. The role of the co-ordination team is at the crux of our approach. Their responsibility is to synthesise the research outputs of the different teams, with the purpose to highlight the convergences and the divergences of the different images of mathematics as identified by the teams. The co-ordination team allows the individual images of mathematics to be conceptually juxtaposed, thus allowing for the diversity to be visible (conceptually and/or perceptually). We posit that through a process of negotiation about the diversity of those images and a series of individual and collective reflections upon this diversity, the Pre-PSTs are allowed to actively re-construct their image of mathematics, emphasising its omni-temporal, universal, yet deeply socio-cultural and anthropological nature.

First, the research teams are provided with the names of famous mathematicians, whose work is a reference to a mathematical topic that may arouse the interest of the group (e.g. non-Euclidean geometries). The Pre-PSTs are free to choose whomever they liked based on their intuition. For example, they may choose a mathematician that is somehow familiar to them, in the sense that they have heard about him/her in school, or that they feel that is socio-culturally close to them (this may be linked to the fact that most of the Pre-PSTs chose ancient Greek mathematicians).

In the following paragraphs, we present the structure of the implementation, along with excerpts of the work of four teams of Pre-PSTs that focussed on Plato, Pythagoras, Archimedes, and Euler (Figs. 7.1, 7.2, 7.3, 7.4, 7.5, 7.6, 7.7, and 7.8).

**Fig. 7.1** Pythagoras, Plato, Archimedes: the person (Pre-PSTs' submitted work; our translation)




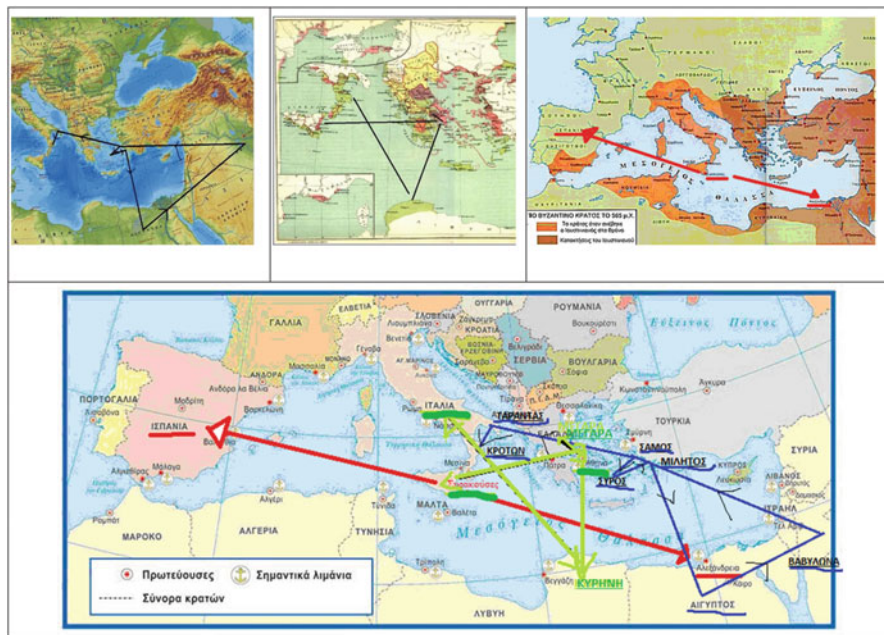
	Pythagoras	Plato	Archimedes
Image	 <a href="http://el.wikipedia.org/wiki/%CE%A9%CF%85%CE%B8%CE%B1%CE%B3%CF%8C%CF%81%CE%B1%CF%82: Bust o di Pitagora. Copia romana di originale greco. Musei Capitolini, Roma">http://el.wikipedia.org/wiki/%CE%A9%CF%85%CE%B8%CE%B1%CE%B3%CF%8C%CF%81%CE%B1%CF%82: Bust o di Pitagora. Copia romana di originale greco. Musei Capitolini, Roma</a>	 <a href="http://en.wikipedia.org/wiki/Plato">http://en.wikipedia.org/wiki/Plato</a> (circa 400-300 B.C.)	 Giuseppe Patania (1780-1852) Biblioteca Comunale (Palermo, Italy). <a href="http://www.math.nyu.edu/~corres/Archimedes/Pictures/ArchimedesPictures.html">http://www.math.nyu.edu/~corres/Archimedes/Pictures/ArchimedesPictures.html</a>
Origins (family) & marital status	- was born between 580-572 BC, son of Myesarchus (rich merchant) and Parthenida - married Theano and they had two boys and a daughter	- was born in 428-7 BC, son of Aristonas and Periction, one of the most eminent families - his brothers were Adimantos and Glaucus	- was born in 287 BC, son of Pheidias. He was related to Hieron (king of Syracuse) and Gelona (tyrant of Syracuse)
geographical areas	- grew up in Samos - went to Syros, Miletus, Egypt (for 22 years) and Italy - Babylon: 12 years in prison	- stayed in Athens and went to Megara, Sicily, Lower Italy, and Cyrene (North Africa)	- lived most of his life in Syracuse, stayed in Alexandria for 34 years and studied, visited Spain
influences /education	- attended the lessons of Ermodamantas and studied with Pherecydes - friendships with Thales (mathematics and geometry) and Anaximander (ontological importance of number and definition in mathematical and numerical terms of the relations of celestial bodies) - learns from the priests of Egypt (geometry, astronomy, science of numbers and music) - was educated with care and diligence (parents, Pythia)	- was a student of Socrates after the age of 20	- studied in Alexandria with teachers the successors of Euclid - friendships with great mathematicians (Konon, Eratosthenes, Dositheos)
Sayings	- «φύλος ἐστὶν ἄλλος ἐγὼ» - «πάντα κατ' ἀριθμῶν γίνονται»	«Αἰεὶ ὁ Θεὸς γεωμετρεῖ» - «Μηδὲς ἀγεωμέτρητος εἰσιτο μοι τὴν θύραν»	«ἐὐρηκα» - «Μη μου τοὺς κύκλους τάραττε»
Political direction	- he preferred the Doric regime (a mixed regime in Sparta, in which an aristocracy rules and equality is limited only to those who are called citizens-soldiers, the kingdom [two kings], the oligarchy [senate] and the tyranny [curators] coexists)	- describes the ideal state in two long dialogues, the <i>Nóμος</i> and the <i>Πολιτεία</i>	
End – Death	- three versions of his death: burned in his house by a fire set by Cylon - the Crotonians slaughtered him along with his disciples - dies of starvation in Metapontium, staying fasting for forty days	- died in 347 BC.	- was murdered in 212 BC at the age of 75, during the looting of Syracuse - there are different versions of his death
Work (educational and scientific [mathematical philosophical politics engineering])	- study of the properties of numbers and the foundation of mathematics, geometry and music - gave ontological significance to the number (prudence of number properties with creation of world) - discovered and proved the asymmetry of the square root of 2 that led to the theory of the number irrational - discovery of five convex regular solids - modern expression 'square number' - equilateral triangles, squares and regular hexagons are the only normal shapes with which we are able to fully cover a flat surface - Pythagorean theorem	- His works are 36 and have the form of philosophical dialogues (State and Laws, Symposium, Apology of Socrates [monologue]), while although he himself is a philosopher his works touch on all subjects - division of mathematics into four branches (Arithmetic, Music, Geometry, Astronomy) - establishment of the Academy (scientific study, philosophical research, political science and mathematics are promoted)	- In the field of engineering: war machines, machines for pumping water, machines calculating distances, levers - In the field of astronomy: calculation of the distances of the planets, planetarium - In the field of mathematics: he gave a method for calculating square roots and $\pi$ , found general methods for finding the areas of curvilinear flat shapes and volumes enclosed by curved surfaces, invented a system by which he could name any number, invented Integral Calculus and predicted the invention of Differential Calculus - created the Hydrostatics giving the positions of calm and balance of the floating bodies - preferred mathematics rather than the brutality of everyday life and applications



Fig. 7.2 Euler: his life and work (Pre-PSTs’ submitted work; our translation)

These excerpts are provided as exemplars of the results of our implementation. Please note the excerpts are all translated to English by the authors and that care was taken so that the style of the translation would be as close to the original text as possible.



**Fig. 7.3** Pythagoras, Plato, Archimedes: their geographical paths (Pre-PSTs’ submitted work)

First, each team starts by choosing the mathematician that would be the topic of their investigations. The teams, working in parallels, are engaged in historical-socio-anthropological research with the aim of revealing the variety of different individual profiles, ideological attitudes, socio-cultural contexts, as well as of geographic areas, historical periods, and particular creative paths in the historical evolution of mathematics (see Figs. 7.1 and 7.2).

The teams conduct structured investigations into different aspects of each mathematician’s life, including a visual image of the person (of a painting, of a sculpture etc), personal work, education, profession, mathematical and scientific work, travel, collaborations, era (socio-cultural and/or political aspects), special abilities, etc. Of particular interest appeared to be the geographical mapping of the mathematicians’ journeys (see Figs. 7.2 and 7.3), as it provides a visual representation that links the person with space, which is also linked with the lived present, thus linking the Pre-PSTs’ lifeworld with the mathematician’s.

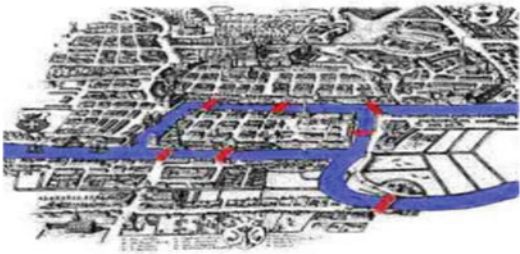
Each team is also expected to work on aspects of a mathematical idea linked with the chosen mathematician (see Figs. 7.4 and 7.5). The topic is also carefully chosen so that it may be, on the one hand, mathematically accessible to Pre-PSTs, and, on the other, to bear great degrees of freedom with respect to the particular focus the team may wish to choose; akin to an open problem.

	Pythagoras	Plato	Archimedes
Topic	- the Pythagorean Theorem has found application in almost every branch of science, pure or applied - even and odd numbers - polygonal numbers	- Platonic solids (tetrahedron, cube, octahedron, dodecahedron and icosahedron)	- Στοιμάχιον - the Boeian problem
- cause motivation (framing)	- the fact that number is not perceived by the senses but by the mind, so the Pythagoreans were forced to consider the essence of beings conceivable and conceived by abstract thought and not material and accessible to the senses. Thus they argued that beings in their inner essence are numbers, which constitute the essential content of beings	- the reason is, in his interactive work "Timaeus", that in his effort to analyze the creation of the world, he introduces with the help of mathematics a model based on the four normal solids	- Archimedes did not deal with The Stomachion as a game (although it evolved into an endearing game in antiquity) but his goal was to find out in how many different ways the 14 flat shapes in which a square is divided by a predetermined pattern can be combined in order to form a square again - Archimedes suggested this numerical problem (Voelikon) in a letter to Eratosthenes and asked him to find the multitude of the bosoms of the Sun God
- possible dimensions (metaphysical, ontological)	- they looked up to the Greek religion and believed in the necessary purification of the soul from the miasma of natural existence and in its liberation from the prison of the body. (Kline,1990:83) The tetractys is said to have been so named because in the triangle each side has 4 tesserae -Geometric representation of numbers	- connects the four elements with the normal solids (fire-tetrahedron, earth-cube, air-octahedron, water-icosahedron) - attempts to mathematicalize nature and recounts how the "shape of the world" was created by the ratio: fire / air = air / water = water / earth	- The Stomachion is the most ancient treatise of Combinatorial (synthesis- reconstruction). It is also possible to create different forms with the combination of ossicles - The Boeikon is a problem that deals with few initial data and simple relationships between them, while the solution is chaotic (oversized in relationships).
- impact	- A combination of geometric shape in essence and sequential arithmetic - Combination of the first, second, third.. (sequential) numbers, which can be constructed through the relationship created with the square area sided with the operative number. It combines the geometric shape with the calculation of the operative number (size), giving a wider dimension. Pentagon-Pedalfa	- Schläfli (1852) proved that there are exactly six regular instruments with Platonic properties in four dimensions, three in five dimensions, and three in all higher dimensions The secret is in the relationships (vertices, edges, faces): analogy and in terms of the elements of nature - Relations of natural phenomena with solids	- the Stomachion is the oldest treatise of Combinatorics: in how many different ways the 14 flat shapes in which a square is divided by a predetermined pattern can be joined together to form a square again: synthesis and reconstruction; also, it is possible to create different forms by combining the ossicles. Bill Culter from Illinois found that there are 536 different ways of reconstructing the square -The Boeikon is a problem that deals with a few initial data and with simple relationships between them, the solution is a huge number (oversized in relationships). The Boeian problem is being given today, to the universities to the students to be solved.


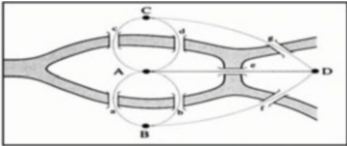
Fig. 7.4 Pythagoras, Plato, Archimedes: mathematical topic (Pre-PSTs' submitted work; our translation)



The mathematical riddle




The inhabitants of the city played a peculiar game with the seven bridges. They asked passers-by to find a way to take a walk in their city and return to the point from where they started, passing through all seven bridges only once. Many said that they had taken such a walk, but when they were asked to repeat it, it was impossible to pass through all the bridges only once.





The attempt of the Swiss mathematician Euler to find a solution to the problem essentially inaugurated the "Theory of Graphs".

The Seven Bridges of Königsberg (now)



It is interesting to see today how many of those bridges are still there. As an important point of the Baltic, the city of Königsberg was a strategic point for the German fleet during the 2nd World War and therefore suffered from very strong bombardments by the allies. Much of the city's historical fabric was razed to the ground, including the famous university on the island in the heart of the city where Kant and Hilbert grew up academically. But the bridges? Three of the pre-war bridges are still there: the "wooden" bridge (Holzbrücke), the "honey" bridge (Honigbrücke) and the "tall" Bridge High (Hohebrücke). Two bridges have disappeared completely: the "carcass" bridge (Köttelbrücke) and the bridge of the "blacksmith" (Schmiedebrücke). The remaining bridges – the green bridge (Grünebrücke) and the bridge of the "merchant" (Krämerbrücke) – had been rebuilt after the war to raise a large transport part within the city.



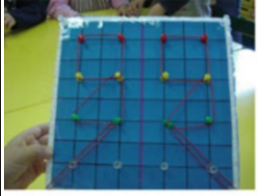


Even with the current picture, the problem cannot be solved, as the number of bridges is unnecessary: 5. Because in areas B and C a perfect number of bridges ends up, then there is always a route that passes through each bridge, exactly once, but without returning to the original point, which is the aim of the problem.

In general, Euler observed that such a route will always be impractical if there are more than two areas in each of which an odd number of bridges ends up.

<https://thalesandfriends.org/el/2014/02/28/oi-gefires-tou-konigsberg/>  
<http://papaveri48.blogspot.gr/2011/05/konigsberg.html>  
<http://eisatopon.blogspot.gr/2011/02/konigsberg.html>

**Fig. 7.5** Euler: The bridges of Königsberg (Pre-PSTs' submitted work; our translation)

The students' investigation about mathematical ideas linked with the mathematician may be also reflected on an educational material that may be used in school for the teaching and learning mathematics in the present era (see Fig. 7.6). Such an investigation crucially links the mathematicians' scientific work with the Pre-PSTs' professional and scientific identity, thus offering the opportunity for the Pre-PSTs to reflect upon the relevance of the mathematics of the famous mathematicians with the

Pythagoras	Plato	Archimedes
		
<ul style="list-style-type: none"> <li>- many references and links, most of them invalid and untrustworthy, many refer to fictions</li> <li>- some do not respond to the developmental stage of early childhood education</li> <li>- the one presented corresponds to the theory of Pythagoras, as numbers are placed in shapes (ontological dimension)</li> <li>- the teaching material is manipulative</li> </ul> <p> <a href="http://www.prasinipriza.com/E3110MATHTYPONO.html">http://www.prasinipriza.com/E3110MATHTYPONO.html</a>  <a href="http://www.pi.ac.cy/pi/files/yap/ekdoseis_yap/dimotikis/maths/math_c/MATH_C_D_56_80.pdf">http://www.pi.ac.cy/pi/files/yap/ekdoseis_yap/dimotikis/maths/math_c/MATH_C_D_56_80.pdf</a> </p>	<ul style="list-style-type: none"> <li>- the material chosen is based on Plato's theories and helps more in understanding the theory of Platonic solids</li> <li>- it is not an ideal example, as such an educational material would be a material that combines the thematic centers of this research, however, it is the closest of the rest</li> <li>- It is made of cardboard and is manipulative</li> </ul> <p> <a href="http://mathlab.mysch.gr/mathimata/2011_visit_A1.html">http://mathlab.mysch.gr/mathimata/2011_visit_A1.html</a> </p>	<ul style="list-style-type: none"> <li>- there are several online teaching apps and games, but they are not easy to use for pre-school children.</li> <li>- the toy pictured above is manipulative, made of wood and can be used more easily by infancy children.</li> <li>- for the Boecian problem, no teaching material-game was found.</li> </ul> <p> <a href="http://geometrytoys.com/2011/06/Archimedes-square-stomachion-puzzle">http://geometrytoys.com/2011/06/Archimedes-square-stomachion-puzzle</a> </p>

**Fig. 7.6** Pythagoras, Plato, Archimedes: educational materials (Pre-PSTs’ submitted work; our translation)

mathematics of the everyday school reality, which includes tangible educational materials (rather than abstract ideas) (Fig. 7.6).

A team member shares their results during the course through a properly structured presentation. In this way, the various paths of each mathematician are mapped on a multidimensional space. The convergences and divergences of these paths are discussed by the team. Their investigations, discussions and reflections are organised in a report, which is also presented (similar to a scientific conference presentation).

The presentations and the reports are important aspects of our approach as through these communicational spaces the Pre-PSTs are given the opportunity to share, to reflect and, importantly, to *voice* their potential re-construction of their image of mathematics.

In some cases, the Pre-PSTs were encouraged to conduct their own small-scale research study, in order to obtain an answer to a research question that derived from their investigation with the literature. For example, a team focussing on Euler discovered his visual impairment (see Fig. 7.4) and reflected upon the links between disability and mathematics. They were encouraged to conduct a study (with a questionnaire they designed) researching the views that people hold about this issue nowadays (see Fig. 7.7). The team reflected upon their findings to note:

**EXPERIMENTAL QUESTIONNAIRE FOR A RESEARCH COURSE**

This questionnaire entitled "Vision Difficulties and Mathematics at school and in everyday life" serves the purposes of a research course of the Department of Early Childhood Education And Educational Planning of the University of the Aegean. The duration of completing this questionnaire does not exceed 10 minutes. There are no correct and incorrect answers. Thank you for your contribution!

**PART 1** For each of the following sentences, choose the answer that expresses you most with an X. 'Vision problems' refer to **serious vision problems** which are on the **spectrum of blindness**.

Mark with the answer that expresses you the most with X	Mark with the answer that expresses you the most with X	Mark with the answer that expresses you the most with X
In your opinion, <b>mathematics</b> as a science is important for the participation of the visually <b>impaired</b> in the development of cultures? I totally disagree Disagree I'm not sure I agree Agree	In your opinion, is mathematics just as important for the participation of the <b>visually impaired</b> in the development of cultures? I totally disagree Disagree I'm not sure I agree Agree	Less important for visually impaired people Just as important More important for visually impaired people
In your opinion, <b>mathematics</b> as a science is useful in the activities of the daily life of people <b>without</b> visual problems? I totally disagree Disagree I'm not sure I agree Agree	In your opinion, is mathematics just as useful in the activities of the <b>visually impaired</b> daily lives of the <b>visually impaired</b> people? I totally disagree Disagree I'm not sure I agree Agree	Less useful for the visually impaired Just as useful More useful for the visually impaired
In your opinion, <b>does mathematics as a science</b> affect the professional development of people <b>without</b> visual impairments? I totally disagree Disagree I'm not sure I agree Agree	In your opinion, do mathematics also influence just as much the professional development of <b>visually impaired</b> people? I totally disagree Disagree I'm not sure I agree Agree	It contributes less for the visually impaired It contributes the same It contributes more for the visually impaired
In your opinion, <b>does mathematics as a science</b> contribute to the development of the logical thinking of people <b>without</b> vision problems? I totally disagree Disagree I'm not sure I agree Agree	In your opinion, do mathematics have the same contribution to the development of logical thinking of <b>visually impaired</b> people? I totally disagree Disagree I'm not sure I agree Agree	They do not contribute for the visually impaired They contribute the same They contribute more for people with visual impairments
In your opinion, is <b>school mathematics</b> for children <b>without</b> visual impairments one of the school courses of increased importance? I totally disagree Disagree I'm not sure I agree Agree	In your opinion, is school mathematics of the same importance for <b>visually impaired</b> children? I totally disagree Disagree I'm not sure I agree Agree	Decreased importance for visually impaired people Same importance Increased importance for visually impaired people
In your opinion, is <b>school mathematics</b> for <b>non-visually impaired</b> children useful for understanding the other courses of the school curriculum? I totally disagree Disagree I'm not sure I agree Agree	In your opinion, are school mathematics equally useful for <b>visually impaired</b> children? I totally disagree Disagree I'm not sure I agree Agree	Reduced usefulness for visually impaired people Same usefulness Increased usefulness for visually impaired people
In your opinion, is <b>school mathematics</b> for children <b>without</b> visual impairments the most difficult subject? I totally disagree Disagree I'm not sure I agree Agree	In your opinion, is mathematics the most difficult school course for <b>visually impaired</b> children as well? I totally disagree Disagree I'm not sure I agree Agree	It is not the most difficult for people with visual impairments It is the most difficult for people with visual impairments
In your opinion, is the performance of <b>non-visually impaired</b> boys and girls differentiated in <b>school mathematics</b> ? Higher performance for the boys Same performance Higher performance for the girls	In your opinion, is the performance of <b>visually impaired</b> boys and girls differentiated in <b>school mathematics</b> ? Higher performance for the boys Same performance Higher performance for the girls	Higher performance for the boys Same performance Higher performance for the girls

**Research Topic:** "Visual Impairments and Mathematics in school and in everyday life"

**Sample:** The sample of our research is opportunistic and consists of 10 men and 10 women.

**Research Tool:** As a tool of our survey, we used the questionnaire method as they can be sent to a large number of people, respondents have the opportunity to express themselves freely. Also, the ways of analyzing the material are standardized. Finally, as researchers, we could not influence the answers.

**Selection of Questions:** The selection of the questions was made in such a way that we cover as wide a range of our topic as possible. We tried to be understandable and simple, so that it is easily and pleasantly complemented by the respondents.

**Commentary on Statistically Important Answers:** The following answers were selected to be commented on, as they have significant statistical value in their interpretation, because they deviate from the mean value (neutral "e.g. I'm not sure").

**Fig. 7.7** The students' investigation about the conceptions about visual impairment and doing mathematics (their instrument and their outline of their study)

On a proper reading of all the above, we conclude that blind people should be treated as normal and not as weaker. A good solution would perhaps be for blind children to have a lesson at the same time as children without visual impairments in the same matter. On the one hand, one of them gets used to each other and respects the particularities of others. To sum up, it is concluded that blindness is not an obstacle to the understanding of mathematics, and Euler's work is there to remind us of it.

It should be stressed that along all the aforementioned steps, the co-ordination team continuously links the seemingly incongruent research spaces within which each research team works.

The course concludes with a joint report that synthesises the work of all the teams, with the purpose to bring into the fore the inherent diversity and universality of mathematics, as a socio-cultural product that derives from and at the same time transcends the human activities.

### ***Large-Scale Implementation: Investigation-Presentations-Reflections-Written Report***

The large-scale implementation with pre-service primary school teachers (Pri-PSTs) is currently in its second iteration. In this chapter, we present its structure and rationale. We implement our approach with a larger number of participants (more than a hundred participants, working in small groups of two to five Pri-PSTs per group). The large-scale implementation draws upon the same principles as the small-scale implementation and it is designed as follows: investigation-presentation-reflection-written report.

A crucial difference between the two implementations is the fact that each team is asked to consider *a pair of mathematicians* (not just one as in the small-scale implementation). In this case, the groups choose amongst a list of pairs of mathematicians, chosen to represent *diversity* with respect to gender, ethnicity, eras, race etc. Some of the famous mathematicians included in that list are: Ada Lovelace, Al-Khwārizmī, Al-Qalasadi, Archimedes, Aristotle, Brahmagupta, Cantor, Descartes, Diophantus, Émilie du Châtelet, Eratosthenes, Euclid, Eudoxus, Euler, Evelyn Boyd Granville, Fermat, Fibonacci, Galois, Gauss, Heron, Hilbert, Hippocrates of Chios, Hypatia, Lobachevsky, Mirzakhani, Noether, Omar Khayyam, Pascal, Plato, Pythagoras, Ramanujan, Sophie Germain, Thales, Theaititos, Theano, Turing, Zhang Heng, etc.

As in the small-scale implementation, the Pri-PSTs may choose based on criteria that are linked with socio-cultural visibility; that is, they somehow consider some mathematicians closer to their socio-cultural experience. However, in this case, a mathematician more familiar to them (e.g. Pythagoras) may be paired with someone less (or no) familiar to them (e.g. Brahmagupta or Erato). Thus, in this implementation, the teams may ask us for some additional information before they commit themselves to a pair of mathematicians. We posit that through the linkings of these seemingly incongruent or even opposing images of mathematics that the lives of different mathematicians communicate, the diversity of the image of mathematics will emerge.

For this purpose, the large-scale implementation employs a series of whole group presentations and reflections. This is at the crux of this implementation, as it is hypothesised to play the role that the co-ordination team played in the small-scale implementation. In order to facilitate this, the same mathematician appears in different pairs, thus constituting a network of relationships: a *social network of historical figures*. Hence, during the process of sharing with the whole group (presenting, asking questions, reflecting), the binary relationships are exploding to multiplicity revealing a network of images of mathematics that derive from, yet transcend the diversity of the mathematicians. We argue that through this process the Pri-PSTs are offered the opportunity to experience an integrated, rather than conflated or biased, image of mathematics.

A. Era [the wider context in which the person lived and acted]
<ul style="list-style-type: none"> <li>● Important historical events of the Era</li> <li>● Socio-political context of the Era</li> <li>● Education System of the Era</li> <li>● Mathematics – Sciences of the Era</li> </ul>
B. Person [socio-demographics of the person]
<ul style="list-style-type: none"> <li>● Image e.g. a photo, a sculpture, a drawing etc.</li> <li>● Time (chronological placement of the Person)</li> <li>● Place (geographical positioning of the Person)</li> <li>● Mapping on a geographical map of the paths</li> <li>● Significant personal or social difficulties e.g. slavery, disability, etc.</li> <li>● Marital status</li> <li>● Social class</li> <li>● Studies – Influences from other important persons</li> <li>● Ending (death)</li> </ul>
C. Work [the work of the person]
<ul style="list-style-type: none"> <li>● Mathematical work</li> <li>● Main contribution to mathematical science; Recognition (when?); Important collaborations with other persons; Influences on other important persons</li> <li>● Other scientific work</li> <li>● Other social, political, artistic work etc.</li> </ul>
D. Presence [Presence of the person and his work in the modern world]
<ul style="list-style-type: none"> <li>● in modern mathematical education, e.g. in school textbooks, in educational material, etc.</li> <li>● in important dimensions of modern mathematics and/or sciences</li> <li>● on important aspects of modern everyday life</li> </ul>

**Fig. 7.8** Investigating the lives of two mathematicians: the four dimensions

Each team is asked to produce a report that investigates the lives of these mathematicians with respect to *four dimensions* (see Fig. 7.8): (a) *Era* (referring to the broader context within which the person lived and acted), (b) *Person* (socio-demographic aspects), (c) *Work* (the mathematical and scientific work of the person), and (d) *Presence* (the presence, if any, of the person in the modern lived present). Importantly, the teams are asked to think about the convergences and the divergences about the lives of the two mathematicians, which is the main reason that we asked the teams to consider two mathematicians. This was important, as in the large-scale implementation there is not time for the teams to be engaged in multiple cycles of investigating and sharing.

Subsequently, the teams are expected to produce a presentation summarising their findings and to present them to the whole class. This process gives the teams the opportunity to share their findings and to critically reflect upon mathematics and mathematicians. Moreover, as already noted, during this process, the whole group is given the opportunity to experience the diversity of the image of mathematics and to focus on and legitimise this diversity rather than to remain entrapped on the apparent polarity that the socio-cultural characteristics of the pairs may include.

Once this phase is completed, the teams are expected to synthesise their findings and to provide feedback of their experiences during the whole-group sharing in a report written that meets the scientific standards.

We had the opportunity to pilot this implementation design with a large group of Pri-PSTs as part of a university course entitled “Development of the science of mathematics (historical roots of elementary mathematics)” in the previous academic year (2021–2022). The concurrent investigations in the scale-up, pilot, iteration of the programme with the Pri-PSTs included 131 students who were engaged in investigating 45 pairs of mathematicians. The Pri-PSTs appeared to follow similar paths that the Pre-PSTs followed in the small-scale implementation. Consequently, this academic year (2022–2023), we implemented this design (with 181 Pri-PSTs investigating 48 pairs of mathematicians), the results of which will be evaluated to further develop our design.

## Concluding Remarks

The integration of cultural and emotional dimensions in the teaching of mathematics seems to create a consensus between the tendencies towards algorithmic thinking and engineering, as well as the tendencies towards a sociocognitive approach and ethnomathematics. Nevertheless, the variety of approaches communicated through such integration, reflects the diversity of conceptions and emotions that we have about culture and mathematics, as well as about their boundaries. Since Piaget’s cyclical epistemology and didactic research on learning situations, we have in fact witnessed a kind of interactive proximity between mathematics and the social sciences. In particular, we have acknowledged the qualitative bridges between the epistemological obstacles at the heart of mathematical scientific development and the academic difficulties observed by constructivist models of research in didactics of mathematics, science and ICT.

By investigating the interactions between mathematics and the organisational thinking, the expressions and expectations of societies and civilizations, as well as the socio-personal paths of the protagonists of science, we argue that it is feasible for the PSTs (both Pre-PSTs and Pre-PSTs) to experience the seemingly paradoxicality of mathematical thought and expression to be at the same time diverse and universal.

An important part of pre-school and primary school mathematics education is for the teachers to support the young learner’s development of logico-mathematical thinking. We posit that it is crucial this development to be intertwined with the young learners’ development of emotional intelligence, as well as with physical and embodied activities, in order to promote their approaching the scientific approach in their construction of knowledge. Furthermore, many pre-school teachers seem to have a negative affective relationship with mathematics, usually linked with negative emotional school experiences and/or with a delimited and skewed image of mathematics as, for example, being a set of rules deprived of links with their everyday life word.

In this chapter, we presented a teacher training programme that functionally and explicitly includes this paradoxical simultaneity by employing the history of mathematics. It is posited that the history of mathematics provides the PSTs with an

epistemological conviction of the need to bring out, express and legitimise the diversity of their future students in their didactic practices, as means for pragmatically addressing the need for inclusive pedagogy in mathematics. Thus, we argue that through this approach, the universality and effectiveness of mathematics may emerge from the documented and lived consideration of the diversity of the manifestations of mathematics, which may be interiorised and inscribed in the school mathematics culture, practices and identity.

We argued that it is crucial to support the PSTs in their constructively re-building their affective relationship with mathematics, in order to be successful in their teaching. Hence, we propose an approach of educating the PSTs that allows them to experience mathematical creation as lived by famous mathematicians, who are humans that acted and interacted in complex scientific, socio-cultural, political settings, thus allowing for their constructing an image of mathematics that is diverse, full of advancements and setbacks, of re-organisations, far from being absolute; a construction, which is of anthropological nature, intertwined with other disciplines, yet clearly distinct from them.

We draw upon an interdisciplinary, systemic approach to introduce a training programme for PSTs that builds upon their historical investigations. The purpose of the programme is multifaceted: (a) to develop mathematical and scientific reasoning qualities, as well as skills about conducting acceptable scientific investigations and presentations, (b) to experience the anthropological nature of mathematical knowledge and its diverse and profound socio-cultural inter-relationships, which co-exists with its relevance with diverse temporal and socio-cultural contexts, and (c) to realise the deep interdisciplinary connections of the generation of mathematics, as well as the interdisciplinary links and appearances of mathematical results. Though it is beyond the scope of the present chapter, it is posited that through experiences of such qualities, the PSTs are expected to develop a well-founded and cognitively oriented positive approach (as opposed to an over-simplified popularisation) of inclusive teaching practices in their future careers.

We discussed two implementation designs: a small-scale implementation (already in its fourth year) and a large-scale implementation (just finished the first year implementation after its pilot phase). We focussed on highlighting “unexpected” (in the dominant discourse) aspects of mathematics and mathematicians, including disability, women in mathematics, non-western mathematics, religion, politics, familial relationships, cross-cultural, cross-temporal, inter-disciplinary journeys. The findings of both the implementations appear to support our approach, as the PSTs seem to develop appropriate qualities that may help them in re-constructing their image of mathematics. Our ongoing research concentrates on the design of the large-scale implementation, including the employment of asynchronous communicational spaces, as well as on creating communicational spaces within which PSTs who are in different year groups may share their investigations in the lives of famous mathematicians, with the purpose for the academic institution (in this case the Department) to establish a systemic professional and academic identity.

## References

- Ananiadou, K., & Claro, M. (2009). *21<sup>st</sup> century skills and competences for new millennium learners in OECD countries*. Organisation for Economic Cooperation and Development. EDU Working paper no. 41. Retrieved from [http://www.oalis.oecd.org/oalis/2009doc.nsf/linkto/edu-wkp\(2009\)20](http://www.oalis.oecd.org/oalis/2009doc.nsf/linkto/edu-wkp(2009)20)
- Applebaum, M. (2015). Activating pre-service mathematics teachers' critical thinking. *European Journal of Science and Mathematics Education*, 3(1), 77–89.
- Arcavi, A., & Isoda, M. (2007). Learning to listen: From historical sources to classroom practice. *Educational Studies in Mathematics*, 66, 111–129.
- Barbin, E., Jankvist, U. T., & Kjeldsen, T. H. (2015). *Proceedings of the eighth European Summer University on history and epistemology in mathematics education ESU 7*. Aarhus University.
- Barbin, E., Jankvist, U. T., Kjeldsen, T. H., Smestad, B., & Tzanakis, C. (2019). *Proceedings of the eighth European Summer University on history and epistemology in mathematics education ESU 8*. OsloMet.
- Barbin, É., Guillemette, D., & Tzanakis, C. (2020). History of mathematics and education. In S. Lerman (Ed.), *Encyclopedia of mathematics education*. Springer. [https://doi.org/10.1007/978-3-030-15789-0\\_69](https://doi.org/10.1007/978-3-030-15789-0_69)
- Betz, N. E., & Hackett, G. (1983). The relationship of mathematics self-efficacy expectations to the selection of science-based college majors. *Journal of Vocational Behavior*, 23, 329–345.
- Boero, P. (Ed.). (2007). *Theorems in school: From history, epistemology and cognition to classroom practice*. Sense Publishers.
- Clark, K. M., Kjeldsen, T. H., Schorcht, S., & Tzanakis, C. (Eds.). (2018). *Mathematics, education and history. Towards a harmonious partnership. ICME-13 monographs*. Springer.
- Ernest, P. (1995). Values, gender and images of mathematics: A philosophical perspective. *International Journal of Mathematical Education in Science and Technology*, 26(3), 449–462.
- Ernest, P. (2008). Epistemology plus values equals classroom image of mathematics. *Philosophy of Mathematics Education Journal*, 23, 1–12.
- Fauvel, J. (1991). Using history in mathematics education. *For the learning of mathematics*, 11(2), 3–6.
- Fauvel, J., & van Maanen, J. A. (Eds.). (2002). *History in mathematics education: The ICMI study*. Kluwer.
- Fried, M. (2001). Can mathematics education and history of mathematics coexist? *Science Education*, 10, 391–408.
- Furinghetti, F. (2007). Teacher education through the history of mathematics. *Educational Studies in Mathematics*, 66(2), 131–143.
- Furinghetti, F. (2020). Rethinking history and epistemology in mathematics education. *International Journal of Mathematical Education in Science and Technology*, 51(6), 967–994.
- Godelier, M. (1977). *Perspectives in Marxist anthropology*. Cambridge University Press.
- Guillemette, D. (2017). History of mathematics in secondary school teachers' training: Towards a nonviolent mathematics education. *Educational Studies in Mathematics*, 96(3), 349–365.
- Hammerness, K. (2001). Teachers' visions: The role of personal ideals in school. *Reform Journal of Educational Change*, 2, 143–163.
- Hannula, M. S. (2002). Attitude towards mathematics: Emotions, expectations and values. *Educational Studies in Mathematics*, 49(1), 25–46.
- Heckman, J. J., & Kautz, T. (2012). Hard evidence on soft skills. *Labour Economics*, 19(4), 451–464.
- Hiebert, J., & Lefevre, P. (1986). Conceptual and procedural knowledge in mathematics: An introductory analysis. In J. Hiebert (Ed.), *Conceptual and procedural knowledge: The case of mathematics* (pp. 1–27). Lawrence Erlbaum.



- Jankvist, U. T. (2009). A categorization of the “whys” and “hows” of using history in mathematics education. *Educational Studies in Mathematics*, 71(3), 235–261.
- Jankvist, U. T., & Kjeldsen, T. H. (2011). New avenues for history in mathematics education: Mathematical competencies and anchoring. *Science & Education*, 20(9), 831–862.
- Jones, S. M., & Doolittle, E. J. (2017). Social and emotional learning: Introducing the issue. *The Future of Children*, 27, 3–11.
- Kasimatis, K., Moutsios-Rentzos, A., & Kalavasis, F. (2021). A systemic approach to authentic evaluation in education. In T. Barkatsas & P. McLaughlin (Eds.), *Authentic assessment and evaluation approaches and practices in a digital era* (pp. 329–349). Leiden, Netherlands. isbn:978-90-04-50155-3.
- Kjeldsen, T. H., & Blomhøj, M. (2012). Beyond motivation: History as a method for learning meta-discursive rules in mathematics. *Educational Studies in Mathematics*, 80(3), 327–349.
- Moutsios-Rentzos, A., & Kalavasis, F. (2016). Systemic approaches to the complexity in mathematics education research. *International Journal for Mathematics in Education (HMS-i-jme)*, 7, 97–119.
- Moutsios-Rentzos, A., & Spyrou, P. (2015). Fostering internal need for proof: a reading of the genesis of proof in ancient Greece. *Philosophy of Mathematics Education Journal*, 29. Retrieved from <http://socialsciences.exeter.ac.uk/education/research/centres/stem/publications/pmej/pome29/index.html>
- Moutsios-Rentzos, A., Spyrou, P., & Peteinara, A. (2014). The objectification of the right-angled triangle in the teaching of the Pythagorean theorem: An empirical investigation. *Educational Studies in Mathematics*, 85(1), 29–51.
- Moutsios-Rentzos, A., Kalavasis, F., & Sofos, E. (2017). Learning paths and teaching bridges: The emergent mathematics classroom within the open system of a globalised virtual social network. In G. Aldon, F. Hitt, L. Bazzini, & U. Gellert (Eds.), *Mathematics and technology* (pp. 371–393). Springer.
- Moutsios-Rentzos, A., Kalavasis, F., & Meimaris, M. (2019). “My relationship with mathematics”: Multimodal realisations and realities. In A. Moutsios-Rentzos, M. Meimaris, & A. Giannakouloupoulos (Eds.), *Proceedings of the international digital storytelling conference “current trends in digital storytelling: Research & Practices”* (pp. 186–194). UNESCO Club of Zakynthos.
- Moutsios-Rentzos, A., Pinnika, V., Kritikos, G., & Kalavasis, F. (2020). Appearances of the equals sign in primary school mathematics and natural sciences: An interdisciplinary, systemic approach. *Quaderni di Ricerca in Didattica*, 7, 285–294.
- Moutsios-Rentzos, A., Kalavasis, F., Meimaris, M., & Kritikos, G. (2022). “My relationship with mathematics”: a digital storytelling-centered investigation with pre-service teachers. Manuscript submitted for publication.
- Munter, C. (2014). Developing visions of high-quality mathematics instruction. *Journal for Research in Mathematics Education*, 45, 584–635.
- Pekrun, R., & Linnenbrink-Garcia, L. (2014). *International handbook of emotions in education*. Routledge.
- Pepin, B., & Roesken-Winter, B. (Eds.). (2014). *From beliefs to dynamic affect systems in mathematics education: Exploring a mosaic of relationships and interactions*. Springer.
- Philipp, R. A. (2007). Mathematics teachers’ beliefs and affect. In F. K. J. Lester (Ed.), *Second handbook of research on mathematics teaching and learning* (pp. 257–315) National Council of Teachers of Mathematics.
- Pinnika, V., Moutsios-Rentzos, A., & Kalavasis, F. (2018). A systemic approach to the image for mathematics: The case of special education. In B. Maj-Tatsis, K. Tatsis, & E. Swoboda (Eds.), *Mathematics in the real world* (pp. 261–270). Wydawnictwo Uniwersytetu Rzeszowskiego. isbn:978-83-7996-554-0.
- Radford, L. (1997). On psychology, historical epistemology, and the teaching of mathematics: Towards a socio-cultural history of mathematics. *For the Learning of Mathematics*, 17(1), 26–33.

- Seah, W. T., Atweh, B., Clarkson, P., & Ellerton, N. (2008). Socio-cultural factors in mathematics teaching and learning. In H. Forgasz, A. Barkatsas, A. Bishop, B. Clarke, S. Keast, W. T. Seah, & P. Sullivan (Eds.), *Research in mathematics education in Australasia 2004–2007* (pp. 223–253). Sense Publishers.
- Skemp, R. R. (1976). Relational understanding and instrumental understanding. *Mathematics Teaching*, 77, 20–26.
- UNESCO. (2005). *Guidelines for inclusion: Ensuring access to education for all*. UNESCO.
- UNICEF. (2007). Promoting the rights of children with disabilities. *Innocenti Digest*, 13, 1–68.
- Voogt, J., & Roblin, N. P. (2012). A comparative analysis of international frameworks for 21st century competences: Implications for national curriculum policies. *Journal of Curriculum Studies*, 44(3), 299–321.

# Chapter 8

## History of Ethnomathematics: Recent Developments



Peter Appelbaum and Charoula Stathopoulou

**Abstract** Ethnomathematics (EM) emerged not only as a challenge to eurocentrism (Powell & Frankenstein, *Ethnomathematics: Challenging eurocentrism in mathematics education*, SUNY Press, 1997), but also as a challenge to mathematics knowledge itself; ethnomathematics questions how histories pre-suppose what counts as mathematics knowledge, and challenges the dominant paradigm of history and its hubris in classifying and prioritizing knowledge. For Ubi D’Ambrosio, considered by many as the intellectual father of EM, EM exists at the confluence of the history of mathematics and cultural anthropology, going beyond the dichotomy of western (academic) and non-western (practical) mathematics.

In this chapter we explore how the EM perspective influences our view of the history of mathematics, placing it in the broader context of history as a discipline, as a western construction, focusing on power relationships that are embedded in the uses of history. This context is central to EM itself, which identifies issues of colonization and related concerns for epistemology, education, and related concerns about equity and globalization. We will also explore the history of EM as it is relevant to thinking about the role of history in the teaching of mathematics; EM had its origins in colonial practices of privileging and legislating knowledge according to Western criteria. A critical perspective on the history of EM leads to our proposal for a “critical ethnomathematics” perspective that can address current problems of education and of the world as a whole.

**Keywords** Ethnomathematics · Multicultural · Intercultural · History of mathematics and mathematics education · Critical mathematics education · Coloniality · Post-colonial curriculum

---

P. Appelbaum (✉)

School of Education, Arcadia University, Philadelphia, PA, USA

e-mail: [appelbap@arcadia.edu](mailto:appelbap@arcadia.edu)

C. Stathopoulou

Mathematics Education, University of Thessaly, Volos, Greece

e-mail: [hastath@uth.gr](mailto:hastath@uth.gr)

© The Author(s), under exclusive license to Springer Nature Switzerland AG 2023

S. Romero Sanchez et al. (eds.), *The Role of the History of Mathematics*

*in the Teaching/Learning Process*, Advances in Mathematics Education,

[https://doi.org/10.1007/978-3-031-29900-1\\_8](https://doi.org/10.1007/978-3-031-29900-1_8)

## **Introduction: Looking for an Ethnomathematics Perspective Before EM-Connection of Culture and Mathematics**

Ethnomathematics, and in general, sociocultural approaches to mathematics education, became a significant focus in the latter half of the twentieth Century, foregrounding mathematics and mathematics education as non-culture-free, and reflecting—in indeed in many ways, formatting—political, social and ideological issues. More than two decades into the twenty-first Century, we can ask, “What can ethnomathematics and its history contribute to the integration of the history of mathematics and mathematics education?” The mutually-informing worlds of mathematics and mathematics education take on different forms, and establish different collections of expectations, outcomes, and institutional practices, depending on the location of their interactions, both conceptually and geopolitically, and are at once sites of historical moments as well as contributors to history in-the-making by everyday people, in everyday ways.

It is challenging to identify specific moments in history or geography when expressions of these connections emerged in academic study or sociocultural awareness. A few texts record limited material, mainly in the form of personal observations, from people who had traveled to different parts of their world. In these records, the authors often recognize distinct cultural practices as well as diversity in the mathematical practices that they noticed. An early effort to relate mathematical concepts and practices with a particular culture seems to be found in the ancient Greek Herodotus’ (Online) *Histories*; this 430 BCE work used anthropological observations from travel to discuss concepts such as ‘equality’ and ‘price’ in specific cultures and described these in a certain form of detachment from the customs and habits of the people of that time. This interest in other cultures has persisted in the European context from antiquity to the present day, in different forms in each historical period. For example, during the Middle Ages, knowledge based on religion prevailed, leading to questions about the beginnings of human existence as well as about ‘exotic’ cultures. These pursuits promoted the ideal of the (Christian) Church. In comparison, the fourteenth Century Arab historian Ibn Khaldun linked environmental, economic, psychological, and social factors to the growth, rise and fall of specific cultures, analyzing economic policies and their consequences for local communities, as well as their contribution to the defense of societies against injustice and oppression by the ruling classes (Rosa & Orey, 2011). In the late 15th and early 16th centuries, European researchers came up with descriptions — often unbelievable to their audiences— of what they experienced as ‘exotic cultures’ encountered during voyages across the Pacific, to Asia, Africa, and the Americas. These descriptions, however, were, usually, ‘folk’ descriptions and not systematic studies.

Often designated as the “first” ethnomathematics text, “Summary of the Stories of Silver and Gold that were necessary for merchants and all forms of fraud in Kingdom of Peru: with some laws related to Arithmetic”, by the Spanish-Mexican Juan Diez Freyle (1556), describes arithmetic practices used by the indigenous peoples of Peru.

Diez Freyle places the arithmetic practices in the context of intercultural dynamics, including the practical efforts of colonizers to exploit the resources of the “new world,” processes of knowledge assimilation interchanged between the European colonizers and the local population, and, as an early example of sociological analysis, specific intercultural interactions leading to transformations in the unfolding development of knowledge systems over time. In *The History of Brazil*, written in 1627 by Frei Vicente do Salvador, there is an extensive claim that the indigenous people of Brazil possessed a number system without numbers greater than five (cited in D’Ambrosio, 2009, p. 6). Do Salvador described the use of fingers and toes in situations needing larger numbers; he further recounted stories of an “exchange system,” during which indigenous people replaced one item with another in a 1–1 match/correspondence, circumventing a number system. By the turn of the 19th and 20th century, anthropology as a discipline can be recognized as carrying forth a particular set of canonical texts that focused on colonized cultures. Number systems, architecture, geometry and other aspects of cultures and customs of specific groups were by this time routinely studied as entries into cultural dynamics, culture-specific cosmologies, aesthetics, and served to clarify by European and other “Western” anthropologists how such cultures could be understood as exotic and different despite common elements of humanity (Said, 1978). Examples include the German mathematician, ethnologist, and educator, Ewald Fettweis (1881–1967), who wrote on “Early Mathematical Thought and Culture,” and the reflections of the French philosopher, George-Henri Luquet (1876–1965), on the “Cultural Origin of Mathematical Concepts” (Gerdes, 1996: 911).

Ubiratan D’Ambrosio spoke at the second Ethnomathematical Congress (D’Ambrosio, 2002) in Ouro Preto, Brazil, identifying the historian Oswald Spengler in the early twentieth Century as the first person to directly mention the existence of more than one kind of mathematics, in his book, *The Decline of the West* in the early twentieth century (1918):

There is not one sculpture, one painting, one mathematics, one physics, but many, each in its deepest essence different from the others, each limited in duration and self-contained, just as each species of plant has its peculiar blossom or fruit, its special type of growth and decline (Spengler, 1918, p. 38)

In Spengler’s chapter on mathematics, he applies his theories of cultural development to write about mathematics as part of culture, and to further describe how individual cultures depend in turn on each of their parts holistically together. In his article, “Meaning of Numbers” (Spengler, 1956) he proposes that something as fundamental –and perhaps misunderstood as universal– as numbers, is indeed culturally-specific: “There is not, and cannot be, number as such.” (Spengler, 1956, p. 2317–2318). There are numerous number-worlds, Spengler writes, just as there are numerous cultures. Spengler, actually, had a theory of a finite number of culture-types, delineating Indian, Arabian, Classical, and Western types of mathematical thought, each expressing its own type of number, fundamentally peculiar and unique, imbued with the potential to express a specific world-feeling, symbols communicating specific validity capable of scientific definition, that is, a principle of

ordering that together reflects the central essence of what he referred to as the soul of that particular culture. An extension of Spengler's theory would lead to the notion that there are more than one form of what anthropologists and historians informally label "mathematics." Historically, we can begin from this point on, to refer to different cultures as reflected in their historical and cultural contexts: the inner structure of Euclidean geometry is something different from that of the Cartesian; the analysis of Archimedes is something other than the analysis of Gauss; the geometric "algebra" of Tartaglia and Cardano fundamentally different from the symbolic algebra following Descartes. These differences are not merely matters of form, intuition, and method, but above all in essence, in the intrinsic and obligatory meaning of number, shape, space, form, and logic, and in the unfolding purposes for which they respectively develop and set forth.

In general, there is increasing acceptance by scholars from the 1930s through the 1970s that mathematics develops as a response to the cultural conditions of its time (Barton, 1996: 1046). Examples of this perspective include, for example, *A Concise History of Mathematics*, by Dirk Struik (1948), which grounded its narrative in sociological analysis. Alvin White's *Essays in Humanistic Mathematics* (White, 1993) emphasized mathematics as something that people "do," as a cultural and human activity, with the explicit proposition that learners of mathematics needed to understand this human aspect of the school subject, and to see themselves as makers of (mathematical) knowledge and history; this work was grounded in the anthropological study of mathematicians as creators of a culture of mathematics.

Mathematician and President of the American Mathematical Society Raymond Wilder looked back on the evolving study of mathematics from a cultural perspective in his 1950 invited address to the International Congress of Mathematicians in Cambridge, Massachusetts, "The Cultural Basis of Mathematics" (1950). He urged his audience to pursue a cultural perspective on their work:

... I do believe that only by recognition of the cultural basis of mathematics will a better understanding of its nature be achieved; moreover, light can be thrown on various problems, particularly those of the Foundations of Mathematics. I don't mean that it can solve these problems, but that it can point the way to solutions as well as show the kinds of solutions that may be expected. In addition, many things that we have believed, and attributed to some kind of vague "intuition," acquire a real validity on the cultural basis (Wilder, 1950, p. 260).

Wilder noted that the study of mathematics from a cultural perspective was not new; he pointed out, however, that anthropologists' observations were primarily limited to arithmetic formulas of what they deemed "primitive" cultures. He reminded those in attendance of the implications of Spengler's standpoint, including how the nature of the mathematics found in a particular culture is indicative of the distinctive character of the culture taken as a whole, and, moreover, that their own beliefs in the "truths" of mathematics were as culture-bound as any other beliefs:

As a body of knowledge, mathematics is not something I know, you know, or any individual knows: It is a part of our culture, our collective possession. We may even forget, with the passing of time, some of our own individual contributions to it, but these may remain, despite our forgetfulness, in the culture stream. As in the case of many other cultural elements, we are taught mathematics from the time when we are able to speak, and from

the first we are impressed with what we call its "absolute truth." It comes to have the same significance and type of reality, perhaps, as their system of gods and rituals has for a primitive people (Wilder, 1950, p. 261).

In his final caveats about presuming a universal, culture-free truth as characteristic of mathematics, Wilder was echoing the anthropologist Leslie White (White, 1947/1956), who wrote, in "The Locus of Mathematical Reality: An Anthropological Footnote," about the fundamental question of "truth" at the heart of mathematics: whether it is "a product of discovery or of invention," of "whether mathematical truths belong to the outside world, to be discovered by humans, or they are human inventions" he suggests that "mathematics in its fullness is 'truths' and their 'realities' are part of human culture." (White, 1947/1956, p. 2350) White believed that Mathematics was not born with Euclid and Pythagoras—or even in ancient Egypt and Mesopotamia—but rather is "a development of human thought that began by the appearance of people and . . . culture; about a million years ago." (White, 1947/1956, p. 2348) Important mathematical ideas are embedded in various cultures, he claimed, strongly situated and different in each culture. His historical perspective assumed the increasing diffusion of such mathematical ideas as a result of exploration and invention, combined with the development and use of appropriate and common symbols, that is, elements from what he understood as more "advanced" cultures, merging to form what would be known as "Mathematics." He proposed, nevertheless, that mathematics should not be considered as a consolidated entity, but instead a subject of constant change (Wilder, 1950, pp. 269–270).

In his later work, "Introduction to the Foundations of Mathematics," Wilder (1965) explicitly explored the cultural foundations of mathematics, including a chapter entitled, "The Cultural Environment of Mathematics." In this work, Wilder makes direct connections to the teaching and learning of mathematics, suggesting that mathematics, compared with other cultural elements, "seems to have a universality without borders." He might have been the first to point out an important issue in the cultural study of mathematics, raising concerns about the motivations behind visiting another culture to look for mathematics, and the dangers of looking in this new culture for what is considered mathematics in that person's home culture (Wilder, 1965). He further worried about what he referred to as "marginal" practices and concepts, those difficult either to integrate into mathematics or to determine as outside of what one is calling "Mathematics." Central to his arguments was the refrain from his earlier address to the International Congress, that "We 'civilized' people rarely think of how much we are dominated by our cultures: we take so much of our behavior as 'natural'" (Wilder, 1981, p.186).

This thread of mathematics as an entry into culture and the study of human meaning was further developed by Philip Davis and Reuben Hersh (Davis & Hersh, 1981, 1986), in two volumes that emphasized mathematics as driven by social forces and as reflecting cultural values. In *The Mathematical Experience*, then-contemporary mathematics was discussed in historical and philosophical perspective, presenting a psychology of mathematics as evidenced by particular stories in the history of European thought, and specific problems that mathematics solved. In

the later Descartes Dream: The World According to Mathematics, Davis and Hersh created a narrative of mathematics as a window into intellectual history; following cultural shifts in the sixteenth Century that lead to a “dream” of the unification of knowledge through mathematics and logic, technological advances and associated cultural beliefs were retold as grander meta-stories about the nature and purposes of knowledge itself. The mutually reinforcing dialogue of mathematical practices and cultural values was, according to Davis and Hersh, important for understanding the conditions of civilization that elicit application of particular mathematical principles. They further demonstrated how the effectiveness of these applications, the situations in which the applications are now perceived as beneficial, dangerous, or irrelevant, and in turn how applied mathematics constrains lives and transforms perceptions of reality, can become the focus of our concerns. In this sense, Davis and Hersh introduced the “historiography” of mathematics and culture, that is, the study of how people create versions of history as itself an important window into understanding the historians themselves as culturally bound.

In 1960, the eminent algebraist Yasuo Akizuki (1959) proposed an emphasis on values in mathematics education, recognized through reflection, and committing to education as preparation for important leadership in the community. His efforts to modernize mathematics education introduced the “History of Science and Mathematics” at all levels, based on his commitment to helping students understand mathematics as a cultural product, and also to promote those instances of mathematics present in Asia:

Oriental philosophies and religions are of a very different kind from those of the West. I can therefore imagine that there might also exist different modes of thinking even in mathematics. Thus I think we should not limit ourselves to applying directly the methods which are currently considered in Europe and America to be the best, but should study mathematical instruction in Asia properly. Such a study might prove to be of interest and value for the West as well as for the East (Akizuki, 1959, p. 288–289).

Mathematicians and anthropologists of the twentieth Century were generally ignorant of Otto Friedrich Raum’s (1938) book, *Arithmetic in Africa*. In the preface, Raum refers to mathematics education, commenting: It cannot really be effective unless it is cleverly based on indigenous culture and the interests of life. He points out, as one of the basic principles of good teaching, the understanding of students’ cultural background, and the need for learning experiences to relate to local cultural practices (Raum, 1938). The interest in connecting school learning experiences to local cultural contexts demonstrated by Raum and later in Japan by Akizuki was unique at this time. A review of the international literature on the cultural dimension of mathematics suggests that such applications did not reach the wider mathematical community, nor educators steeped in the acceptance of mathematics as reflecting universal truths, until more recently. Despite indications of a close link between cognition and the cultural environment, there has been in general an oversimplification of mathematics. This trend has its roots in Descartes, and has dominated, and to a large extent continues to dominate, education (Walkerline, 1988). It is characterized by the notion that mathematics is a type of knowledge independent from cultural contexts (Lancy, 1983), and interwoven in fantasies of control and power



(Walkerdine, 1988), despite the few scholars we have discussed so far in this chapter. However, bubbling up in the cultural and political contexts of the 1960s and 70 s was a more critical perspective on truth and values in the so-called “Western” and “Developed” nations, so that, by the 1980s, implications for mathematics education were deemed obvious by various researchers and scholars, of whom the previously mentioned D’Ambrosio (1985), is a preeminent example.

## **Culture and Mathematics: Post-colonialism and the Emergence of Ethnomathematics**

The previous section of this chapter discussed inchoate scholarly awareness of mathematics as a cultural endeavor, and occasional connections to mathematics education during periods of history prior to the advent of the term “ethnomathematics.” This section places the emergence of ethnomathematics in its own historical, political, social and cultural context. Circumspection leads to the awareness that “culture” itself was/is as much a cultural and geopolitical concept tied to colonialism as mathematics might be. Neither mathematics nor culture is a neutral term, and both, individually and together, developed mutually as reinforcing structures of power and hierarchy (Appelbaum & Stathopoulou, 2015). Economic exploitation and political forms of imperialism during colonization buttressed assumptions about “the extension of civilization,” ideologically justifying racial and cultural fantasies of superiority of “The Western World” over the “non-Western World.” Forms of knowledge acted as forms of enlightened justifications for colonizing other regions of the world. The twentieth Century witnessed decolonization. European powers began to separate themselves from their former colonies following World War II, which undermined their sense of invulnerability, white supremacy, and found outwardly anti-colonial powers such as the United States and the Soviet Union replacing official colonialism with economic and political imperialism. Former colonies experienced nationalist movements and demanded independence. Nevertheless, despite numerous decolonization processes leading to new nation states and increased independence of formerly colonized regions in the world, many structures of dominance and hierarchy remained, culturally, economically, geopolitically, and ideologically, mutually maintaining forms of privilege and oppression that are collectively understood today as “coloniality.”

The post-colonial period can be theorized through the work of French West Indian Franz Fanon (1952, 1961), who meticulously analyzed colonialism as a destructive force, harmful to indigenous people subjugated to colonial status, and ideologically damaging to societies systematically denied attributes of being human. Fanon understood colonialism as a “total project” ruling all aspects of colonized reality. The totalizing functions of colonization force the colonized to see themselves with the language and ideologies of the colonizers, losing their own cultural resources for self-identity. Considering school mathematics as originating within

this structure of colonization, mathematics as a collection of tools for making meaning would in this sense contribute to this harmful system of colonialism.

A parallel analysis of colonialism and its legacy by the Palestinian American Edward Said (1978) reinterprets the colonialist hierarchies and justifications with heightened attention to the binaries established by the “Western colonizers” and the “Orient” or others, enabling Europeans to suppress the communities of the Middle East, the Indian Subcontinent, and of Asia in general, and intellectually preventing these communities and cultures from expressing and representing themselves as discrete. “Orientalism” in this way, according to Said, lumped together and narrowed the non-Western world into a homogenized, simplified, cultural entity known as “the East,” supporting imperialism and in turn the assumptions of this “Oriental World” as inferior and backward, irrational and wild, as opposed to a Western Europe that was superior and progressive, rational and civil. School mathematics within this perspective can be understood as serving Orientalism by establishing itself as a uniquely progressive and rational tool of civilization, enforcing its will against the dangers of the wild and irrational.

Early Ethnomathematics emerged in this context, serving two primary functions: as recognition of the situation; and, paradoxically, as a resource for perpetuating the hierarchic legacies of colonialism, or coloniality. In the first of these roles, ethnomathematics provided a perspective that explained why colonized populations might struggle with school mathematics. In this role, ethnomathematics offered forms of local culture that shared properties with the mathematical concepts and skills that were transported from Western European curricula into local lives in and out of school. Ethnomathematics also functioned in the contrasting second role, as a colonization perspective on subjugated cultures exploitable in Western European school programs: examples of traditionally taught mathematics ‘found’ in ‘indigenous’ practices around the world, used in Western school curricula, coopted mathematics in this way as a tool of coloniality; that is, the use of non-European examples in the teaching of mathematics as practiced in many schools today is an example of a structure of coloniality, just as the teaching of traditional, Western mathematics around the world, taken as ‘the universal definition of mathematics’ for all, is itself a structure of coloniality. The further identification of a local tradition – say, street mathematics, home crafts and textile work, tile design on walls, etc. – as ‘just as much mathematics as Western European mathematics’ is the ultimate example of coloniality: something is recognized and legitimized as mathematics if and only if it looks like what the colonizing culture sees as mathematics. Entire realms of mathematical activity are in this way reduced to those attributes that conform to the colonizing epistemological structures, and others are forever lost to humanity since they are not in this way visible as forms of mathematics. Paulus Gerdes (1994) reflected on the early history of ethnomathematics in a similar way, noting that the late 1970s and early 1980s witnessed a growing awareness among mathematicians of the societal and cultural aspects of mathematics and mathematics education; he credits Ubiratan D’Ambrosio for proposing an *Ethnomathematical Program* as a

methodology to track and analyze the processes of generation, transmission, diffusion, and institutionalization of (mathematical) knowledge in diverse cultural systems. His own life's work is stunning in its depth and breadth, developing new curriculum materials and school programs celebrating indigenous traditions of Mozambique, and supporting similar work internationally by others.

Colonization maintained an ongoing suppression or total erasure of local knowledges, and the totalizing expectation that the colonized learn and assimilate the epistemologies, knowledges, and associated 'ignorances' of the colonizers; coloniality preserves many of these practices to this day. Gerdes (1994) spoke of "frozen knowledge" (p. 20), the oppressed or lost knowledge of formerly colonized people. Colonization and Coloniality construct a hierarchy of knowledges and practice that privilege Western European modes as superior, often going so far as to obliterate the existence of available alternatives. In order to function in society and to find a means of basic survival and subsistence, subjects of colonization and now of coloniality have needed to cross boundaries of culture, knowledge, and modes of thinking, and 'live' in the world views and epistemologies of the colonizers, either by force or simple survival strategy.

A brief flirtation with multicultural methods in the 1980s and 1990s led to classroom activities connecting mathematics to: games and practices from non-Western cultures (see, e.g., Zaslavsky, 1993, 1996, 1998; Whitin & Wilde, 1995; Lipka et al., 2007); non-standard calculation procedures and algorithms (Knijnik et al., 2005; Moreira, 2003; Moreira & Pires, 2012; Orey & Rosa, 2008; Stathopoulou, 2005; Stathopoulou & Kalabasis, 2002); multiple representations of mathematical concepts (Barton, 1995; Favilli, 2007; Gerdes, 1988; Palhares, 2012), and to a cultural pride linked to mathematics (Appelbaum, 1995; Gutstein, 2003; Matthews, 1989; Moses & Cobb, 2001). There have been parallel efforts to develop school mathematics activities and projects that take advantage of the funds of knowledge that students bring to school from home and community cultures (see, e.g., Gerdes, 1988; Civil & Kahn, 2001; Stathopoulou, 2006; Klein & Showalter, 2012). Nevertheless, there remains a limited focus on using social practices from "other," non-mainstream cultures to lure learners into an understanding of traditional mathematics content (Bazin & Tamez, 2002). Few culturally-sensitive curricular practices that work with the culturally specific knowledge that learners bring to school support these learners in their taking what is enhanced or refined in school back into their home cultures. Even the more politically sensitive approaches to mathematics teaching and learning (Frankenstein, 1989; Gutstein & Peterson, 2005) assume the mathematics to be politically neutral, however politicized its applications. And few research projects, curriculum development efforts, or cross-cultural collaborations in mathematics education take seriously the notion that potentially confusing and complex multiplicities of cultures and identities are manifest in what might be taken on first glance to be a single, monolithic "culture" in contemporary, post-colonial, creolized "inter-cultural" contexts (Appelbaum, 1995, 2008; Valero & Stentoft, 2010; Swanson & Appelbaum, 2012, Chronaki, 2005).

The impact of an ethnomathematics perspective has made its mark on mathematics educators, at least in terms of an articulated importance. As recently as 2007, Norma Presmeg wrote that mathematics education had “experienced a major revolution in perceptions,” so that “mathematics, long considered value- and culture-free, is indeed a cultural product, and hence that the role of culture – with all its complexities and contestations—is an important aspect of mathematics education” (Presmeg, 2007, p. 435). Yet, as late as the revised edition of *Against Common Sense*, Kevin Kumashiro could write in 2009 that, “More than any discipline, math is considered by many people to be the least influenced by social factors, and, therefore, to be the most bias-free of all subjects being taught and learned in school. People have told me that race might matter when treating students of color differently in a math classroom, but race has little, if anything, to do with adding and subtracting numbers” (Kumashiro, 2009, p. 111). Virtually the same comments can be found in most of the references already cited in this paragraph, from at least as long ago as the 1970s, indicating how little the stated impact has been reflected in actual practices.

Some point to 1977 as the establishment of ethnomathematics. This was the year that Ubiratan D’Ambrosio first used the term in a presentation to American Association for the Advancement of Science, initiating an ongoing set of questions about what the field might actually entail, yet always referring to the “ethno” and “mathema” for their categories of analysis, and “tics” from *techne*, which refers to making or doing. In this way, ethnomathematics begins with an interest in “The mathematics which is practiced among identifiable cultural groups such as national-tribe societies, labour groups, children of certain age brackets and professional classes” (D’Ambrosio, 1997, p. 16). This leads scholars of ethnomathematics to the mathematical ideas of people who have generally been excluded from discussions of formal, academic mathematics. Research into the mathematics of these cultures constructs two contradictory viewpoints: first, that the objectivity of mathematics is due to it being something discovered, external to a person, and not constructed; Second, however, is the realization that the usefulness of mathematics obscures its cultural constructs. What is now identified as “critical ethnomathematics” centers those aspects of ethnomathematics that speak to the political and social justice aspects of the field. Here one challenges the ideological and unquestioned applications of terms such as culture and mathematics for their implicit perversions and structural forms of coloniality, and especially for those ways in which schools, educational policy, popular culture representations of mathematics and mathematicians, and government sanctioned applications of mathematics to the solution of social problems, perpetuate assumptions about the neutrality of a universal, Western version of mathematics, the erasure of local mathematical ways of being, and a contemporary, postcolonial orientation to equity. Of increasing importance are post-human theories that decenter humanity in the sustainability of a planet in peril for its own survival, and the ways that an unquestioned use of mathematical approaches might be countered by previously ignored forms of knowledge and knowing (Appelbaum et al., 2022; Khan et al., 2022).

## Whither Ethnomathematics?

Ethnomathematics, and especially critical ethnomathematics, does not claim itself as a panacea, but as a framework to enhance the development of hybrid spaces inside and outside school, spaces that instead of focusing on differences attempt collective efforts pursuing a better world – a world of dignity, equity, and social justice. Some versions of this include what George Joseph (1994) once called “antiracist mathematics,” constituted both by the study of the history of mathematics outside of Europe and important parallel histories in non-European regions of the world, and by the avoidance of stereotypes in school curriculum materials; this requires attention to both the formal, official curriculum, and the hidden, or informal curriculum of school mathematics, the latter being of crucial importance in conveying values and assumptions passed on by teachers and schools regarding the nature of knowledge, the potential of students, and the place of mathematics in the lives of individuals. Other versions, building upon the literature of “culturally relevant” and “culturally responsive” pedagogy (Gay, 2010; Leonard, 2008), design school curriculum to use these expansive histories of mathematics to empower learners to excel academically by validating and affirming local cultures, centering local cultural traditions and practices in the learning of mathematics, and intentionally transforming school experiences through the explicit study of such broader histories of mathematics.

Appelbaum and Stathopoulou (2020) encourage educators to make coloniality itself the focus of mathematics education curriculum development, by assisting local communities of learners in the re-appropriation of “Western” school mathematics for the solution of local problems. This might be described as an application of the history of mathematics and its associated erasure of local knowledges within problem-based-learning STEM and STEAM approaches to mathematics education, using the following logic: Just as colonizers can be said to have ‘raped’ and exploited the natural resources and human labor of the colonized, so have the colonized always found ways to exploit and appropriate the tools of the oppressors for their own needs. There are limitations to this way of living coloniality; in the words of Audre Lorde, “the master’s tools will never dismantle the master’s house.” (Lorde, 1979), Nevertheless, the goal is not so much to dismantle the master’s house, but to live as one wishes and to flourish as one dreams, independent of that stranger’s craziness; and the local knowledges as the authorities bring more than the ‘master’s tools’ to the project – they bring the rich practices and traditions of local culture, and a curiosity to appropriate and blend ways of thinking and being from all over the world if they are relevant to the task at hand.

Structuring mathematics education around re-appropriation shares many characteristics with what Palestinian mathematics educator Munir Fasheh et al. (2017) highlights as rooted wisdom guiding teaching and learning for all. Fasheh uses the Arabic word *mujaawarah* to refer to a collectivity of people self-selecting to be together, and who function without the need of a permit, budget, hierarchy, or set of rules. Collective thinking and reflecting, situated in specific contextual concerns instead of merely abstract analytical/critical thinking, enables each member of the

*mujaawarah* to contribute what they do well, and to see themselves as useful, beautiful, and giving. This cultural orientation to learning in general, as a formative perspective on mathematics education, encourages mathematics educators to shift their focus away from specific content objectives toward the primary creation of learning communities that facilitate each member to be respectful of their own “worth rather than being part of a hierarchical or normative evaluation of worth,” embodying the logic of *muthanna*: ‘you are, therefore I am’” (Fasheh et al., 2017, p. 298).

Meaningful teaching requires being personal about what one teaches. A rooted teacher is one who has gone through a long period of diverse experiences, reflected upon them and put an effort to make sense out of them, and who is ready to share one’s experiences, doubts and concerns with others as open matters – rather than delivers them as ready information and skills or fixed capacities to be consumed. Teaching any subject wisely (and not only math) requires reclaiming two other ignored aspects in living and learning: soil and memory. Community consists of several soils that enrich one another and nurture the intellectual growth in community: earth soil; cultural soil; social soil; and economic soil – all of which necessarily embody memory. Nurturing these soils and memories, and being nurtured by them, is our vocation as teachers (Fasheh et al., 2017, p. 299).

The diverse experiences to which Fasheh refers often include mathematical learning experiences highlighting the ways that mathematics can be a powerful tool to move along an apparent path of progress. Schools typically promote mathematics as a “subtle weapon” to “monopoliz[e] what constitutes knowledge” (Fasheh, 2012, p. 94). “As a result,” writes mathematics educator Nirmala Naresh (2015), “I held a narrow perception of mathematics that limited my ability to perceive and present mathematics as a human activity.” Naresh found through ethnomathematics that she had been oblivious to the mathematical ideas on the walls of her grandmother’s ancestral home, the *kolam* designs and *rangoli* patterns on the thresholds of the homes in her neighborhood, the mental mathematics embodied in the activities of “just plain folks in my community,” and the contributions of her forerunners to the historical evolution of mathematical ideas. Naresh has subsequently designed a critical mathematics education program designed so that activities include cultural, social and political, and historical dimensions. After implementing the program, she reports,

We understood and embraced the concept that if we failed to produce meaningful dialogue (between teachers and learners), or if dialogue is absent, change cannot occur. As a learning community, we have come to realize that it is important to “empower students, through broadening, not narrowing their knowledge of mathematics; through inspiring their participation and creativity in contributing to the development of mathematical knowledge, and, for teachers, through the creation of a culturally responsive teaching (Mukhopadhyay et al., 2009, p. 72, quoted in Naresh, 2015, p. 468).

Ron Eglash (1999, p. 223) developed many extensions of his ethnomathematical research projects on recursion in African cultures, both for local exploitation of cultural aesthetics and cosmology and for increasing engagement in learners of the African diaspora. While the notion of increasing engagement of, for example, African American students, through the study African mathematical activities should

be unpacked for its complicated assumptions about learners and culture, the ideas of fractal design as historically present across the enormous continent of Africa, despite this topic's emergence in Western mathematics as late as the twentieth century demands serious reflection. Bamana sand divination (Eglash, 1997) works as an indigenous example of recursion: The Bamana diviners pass outputs of an operation back through an algorithm as the new inputs, iterating the process until certain criteria are met. Eglash (1999) also proposes directions for development by interconnecting African fractals (indigenous design) and modern computing. He mentions a few existing applications such as a Ghanaian national television broadcast test pattern and projects in Burkina Faso that combine traditional fractal architecture with modern techniques. Eglash mentions potential applications to the organization of production and vending, decentralized electronic voting (decision making in many African cultures is traditionally decentralized), and neural-net style decision making. Through his ethnomathematics projects, Eglash has come to understand African fractals as a potential framework rooted in indigenous cultures, and possibly applied to the solution of local problems.

Gelsa Knijnik (2005, 2007) has used an ethnomathematics perspective to better understand adult education in the context of the Brazilian Landless Movement. Her projects integrate the study of Eurocentric discourses constituting academic mathematics and school mathematics along with a parallel analysis of the effects that these discourses of academic mathematics and school mathematics in specific communities. The issues of difference in mathematics education when interpreted through lenses of culture and the power relations that institute it leads to a recognition of a dichotomy between "high" and "low" cultures in mathematics education. Knijnik's ongoing work with peasants of the Brazilian Landless Movement, participants in adult education courses as students or as teachers, help her to describe and interpret this social movement, especially in terms of the educational work they are developing. By combining the ethnomathematics perspective on different worlds of mathematics, the analysis of the mathematics produced by the Landless peasant form of life, ethnographic study of the relationships that individuals have with school mathematics, and the problematizing curricular issues of adult mathematics education, she can report on ways that life inside and outside of school constrain and enable each other. Since the mathematics of everyday life that they grow up with as part of being a human being is culturally a part of their way of giving meaning to life, it would be almost impossible to ignore the necessary close connections between this kind of mathematical practice, which Knijnik describes as "oral mathematics," and the school curriculum. When they join adult education projects, their peasant culture comes with them, even when the school curriculum tries to impose a sort of "forgetfulness" about who they are, the music they enjoy, the food they appreciate, the grammar they use when talking, the grammar they use when adding, subtracting, multiplying and dividing, and so on. When this subtle imposition of denying their culture occurs, it is not surprising to see that it brings with it a resistance process. This resistance can be expressed by adult peasants through rejection of school (no-learning attitudes); can be expressed by pretending that they accept such an imposition (simply pretending). When they go outside school, their peasant

mathematics is revived, showing that it can survive the school conservative practices that are bound by only one kind of rationality, one kind of language-games as mathematics.

Daniel Orey and Milton Rosa have pursued the combination of ethnomathematics and mathematical modelling (Orey & Rosa, 2011, 2021). Ethnomodelling takes into consideration diverse processes that help in the construction and development of scientific and mathematical knowledge that includes collectivity, and the overall sense of and value for creative and new inventions and ideas. The processes and production of scientific and mathematical ideas, procedures, and practices operate as a register of the interpretative singularities that regard possibilities for symbolic constructions of the knowledge in different cultural groups. In this context, Orey and Rosa understand ethnomodelling as the intersection of three research fields: cultural anthropology, ethnomathematics, and mathematical modelling. In the ethnomodelling processes that they facilitate in educational environments, the intersection between mathematical modelling and ethnomathematics relates to the respect and valorization of previous knowledge and traditions developed by students, enabling the students to assess and translate problem-situations by elaborating mathematical models in different contexts. Local, or emic, ethnomodels are representations developed by the members of distinct cultural groups taken from their own reality as they are based on mathematical ideas, procedures, and practices rooted in their own cultural contexts, such as religion, clothing, ornaments, architecture, and lifestyles. Global, or etic, ethnomodels are elaborated according to the view of the external observers in relation to the systems taken from reality. In this regard, ethnomodellers study mathematical practices developed by members of different cultural groups with common definitions and metric categories. However, glocal, or dialogical, ethnomodels are based on the shared understanding that complexity of mathematical phenomena is only verified within the context of cultural groups in which they are developed. In these ethnomodels, the emic approach seeks to understand a particular mathematical procedures based on the observation of the local internal dynamics while the etic approach provides a cross-cultural understanding of these practices.

Such examples demonstrate how ethnomathematics should be understood as a pedagogical action beginning with teachers and students together thinking about how they use mathematics in everyday and academic contexts (Rosa & Orey, 2016a, b). They also dramatize the ways that ethnomathematics balances the ethno-science tendency to fix the subject of study in ways that deny its fluidity with the ethno-science commitment to the kind of recognition and dignity that results from facilitating the ongoing making of mathematics as history by those researched, those learning, those teaching, and those making educational policy. Ethnomathematical practices, once embraced and then generated by a particular cultural group, is itself not only the result of interactions with the natural and social environment, but also subjected to interactions with the power relations both among and within cultural groups (Vithal & Skovsmose, 1997, p. 11). Ethnomathematical studies have been more successful at demonstrating the ways in which this has unfolded between the Eurocentrism of academic mathematics and the mathematics of identifiable cultural



groups, but has yet to be effective in applying a similar analysis to the analogous situation occurring within an identified cultural group trying to use the ethnomathematical perspective in meaningful ways. Understanding these distinctions makes it possible for students and teachers to integrate culture and mathematics through creating a transformational and comprehensive environment that honors diversity as acceptable, essential and important to living in a modern world.

## **Coda: History and Historiography**

What is often presented as “History of Mathematics” is a progressive, straightforward story of “Western Mathematics” marching forth through periods and moments of growth or stasis, always moving toward clarification of truths within given structures of knowing and acting. Ethnomathematics challenges this perception by making spaces for “other” worlds of mathematics not included in this corpus of knowledge; it further challenges the pedagogical implications of this orientation for what should or could take place in a mathematics classroom. Once the cultural construction of mathematics is clear, the cultural and ideological construction of the history of mathematics is that much apparent. The need for students of mathematics to understand the cultural, historical and ideological contexts for what they are learning becomes an ethical obligation. What might have been seen merely as a useful resource among others for motivating learners takes on far more powerful roles in mathematics education. First of all, an historical perspective alters what the students are learning not only in terms of the literal content, but more importantly in terms of the story about that content that they are experiencing. Experiences that place the mathematics of a time and place in the context of the questions that were asked, the social, economic and political perspectives of the people asking these questions, the uses to which the mathematics was put, and the directions not taken, create a story of human beings making knowledge as part of their making of human history – intellectual history of what has later been labelled “mathematics,” as well as forms of interaction with the world, with other human beings, and further forms of social and political life intertwined with the mathematics of that time and place. The historical perspective further facilitates students in the extraordinary re-experience of mathematics they have learned in a version usually taken out of social and political contexts, now situated in contrasting forms of representation and used for culturally different purposes, facilitating the awareness of mathematics as something fully human, made by humans, and having human consequences. Such experiences have the greatest impact when they help students see themselves as capable of making mathematics themselves, by nature of being human beings; if these experiences moreover help students to recognize the responsibilities thrust upon them by this cultural awareness, this is yet a more powerful mathematics education. When they ask, “Who has written *this* version of the history of mathematics?” they are embarking on a critical ethnomathematics perspective.

Ethnomathematics has reached a place in its own development where it is necessary to reflect on who is writing the history, not only of mathematics, but of ethnomathematics. How and why have different people told different stories about ethnomathematics, and how does this matter? And, for whom does this matter? Just as ethnomathematics has from its beginning told the story of mathematics as multiple, cultural, ideological, political, at the focal point of colonialism and colonality, the history of ethnomathematics is necessarily understood as multiple, cultural, ideological, political, and at the focal point of colonialism and colonality. (At times, for example, the study of local cultures has served to define indigenous communities as “needing” Western school mathematics, or as needing special forms of cultural relevance to “help them” – as others, othered by colonality – to learn mathematics. At other times, the study of “exotic” non-Western mathematics has been exploited to create new and engaging forms of mathematical examples for mathematics classrooms, ostensibly in the guise of multiculturalism, yet preserving outdated and offensive forms of self-congratulatory superiority for those in dominant, primarily Western, cultures.)

This chapter itself is an artifact of its historical moment, composed by a U.S.-American university professor and a Greek university professor, each of whom bring specific life histories and cultural assumptions to the study of ethnomathematics and mathematics education. History has been at times naively understood as a record of events. At other times, history is better understood as the stories of who we have become; ethnomathematics in its various forms tells the stories of colonality. In yet other times and places, history is the stories we tell in order to explain our futures. What are the futures that the authors of this chapter wish to tell? One is the story of mathematics as a collection of tools for a post-colonial recognition of the need for new relationships in and out of mathematics classrooms with the practices of mathematics and mathematics education. Another is the story of ethnomathematics in dialogue with mathematics education, evolving together in the pursuit of social justice and a sustainable planet. Some stories will be re-written, with new perspectives, by ourselves and others.

## References

- Akizuki, Y. (1959). Proposal to I.C.M.I. *L'Enseignement mathématique*, *Genebra*, 5(4), 288–289. <https://www.e-periodica.ch/cntmng?pid=ens-001:1959:5::109>
- Appelbaum, P. (1995). *Popular culture, educational discourse, and mathematics*. State University of New York Press.
- Appelbaum, P. (2008). *Embracing mathematics: On becoming a teacher and changing with mathematics*. Routledge.
- Appelbaum, P., & Stathopoulou, C. (2015). Critical issues in culture and mathematics learning. In L. English & D. Kirshner (Eds.), *Handbook of international research in mathematics education* (pp. 744–798). Taylor and Francis.
- Appelbaum, P., & Stathopoulou, C. (2020). The taking of Western/Euro mathematics as reappropriation/repair. *Revemop*, 2, e202003.

- Appelbaum, P., Stathopoulou, C., & Xenofontos, C. (2022). Mathematics education as dystopia: A future beyond. *Journal of Humanistic Mathematics*, 12(2) <https://scholarship.claremont.edu/jhm/vol12/iss2/2/>
- Barton, B. (1995). Making sense of ethnomathematics: Ethnomathematics is making sense. *Educational Studies in Mathematics*, 31(1–2), 201–233.
- Barton, B. (1996). Anthropological perspectives on mathematics and mathematics education. In A. J. Bishop et al. (Eds.), *International handbook of mathematics education* (pp. 1035–1053). Springer.
- Bazin, M., & Tamez, M. (2002). *Math and science across cultures: Activities and investigations from the Exploratorium*. The New Press.
- Chronaki, A. (2005). Learning about ‘learning identities’ in the school arithmetic practice: The experience of two young minority gypsy girls in the Greek context of education. *European Journal of Psychology of Education*, 20(1), 61–74.
- Civil, M., & Kahn, L. (2001). Mathematics instruction developed from a garden theme. *Teaching Children Mathematics*, 7(7), 400–405.
- D’Ambrosio, U. (1985). Ethnomathematics and its place in the history and pedagogy of mathematics. *For the Learning of Mathematics*, 5(1), 44–48.
- D’Ambrosio, U. (1997). Ethnomathematics and its place in the history and pedagogy of mathematics. In M. Fankenstein & A. Powell (Eds.), *Ethnomathematics: Challenging eurocentrism in mathematics education* (pp. 13–24). State University of New York Press.
- D’Ambrosio, U. (2002). Ethnomathematics: An overview. In M. de Monteiro (Ed.), *Proceedings of the second international congress on Ethnomathematics (ICEM2)* (pp. 4–7). Lyrium Comunacacao Ltda.
- D’Ambrosio, U. (2009). A dinâmica cultural no encontro do velho e do novo mundo. *Eä Revista de Humanidades Médicas & Estudios Sociales de la Ciencia y la Tecnologia*, 1(1), 1–25.
- Davis, P. & Hersh, R. (1981). *The mathematical experience*. Birkhäuser.
- Davis, P., & Hersh, R. (1986). *Descartes’ dream: The world according to mathematics*. Dover.
- Eglash, R. (1997). When math worlds collide: Intention and invention in ethnomathematics. *Science, Technology, & Human Values*, 22(1), 79–97.
- Eglash, R. (1999). *African fractals: Modern computing and indigenous design*. Rutgers University Press.
- Fanon, F. (1952). *Black skin, white mask* (1986 Edition, with a foreword by H. Bhabha). Pluto Press.
- Fanon, F. (1961). Letter to the youth of Africa. In *Political essay, later published in toward the Africa revolution*. Grove Press.
- Fasheh, M. (2012). The role of mathematics in the destruction of communities, and what we can do to reverse this process, including using mathematics. In O. Skovsmose & B. Greer (Eds.), *Opening the cage: Critique and politics of mathematics education* (pp. 92–105). Brill.
- Fasheh, M., Abtahi, Y., & Chronaki, A. (2017). *Mujaawarah: Being together in wisdom or reclaiming life for mathematics*. In A. Chronaki (Ed.), *Proceedings of the ninth international mathematics education and society conference* (pp. 298–312). MES.
- Favilli, F. (Ed.). (2007). *Ethnomathematics and mathematics education, Proceedings of the 10<sup>th</sup> International Congress of Mathematics Education, Discussion Group 15: Ethnomathematics*. Tipografia Editrice Pisana, Pisa.
- Frankenstein, M. (1989). *Relearning mathematics: A different third R – Radical maths*. Free Association Books.
- Gay, G. (2010). *Culturally responsive teaching: Theory, research, and practice* (2nd ed.). Teachers College Press.
- Gerdes, P. (1988). On possible uses of traditional Angolan sand drawings in the mathematics classroom. *Educational Studies in Mathematics*, 19(1), 3–22.
- Gerdes, P. (1994). Reflections on Ethnomathematics. *For the Learning of Mathematics*, 14(2), 19–21.
- Gerdes, P. (1996). On ethnomathematics and the transmission of mathematical knowledge in and outside of schools in Africa south of the Sahara. In R. Waast (Ed.), *Les sciences hors d’Occident au XXème Siècle (Science et développement)* (Vol. 5, pp. 229–246). ORSTOM/UNESCO.

- Gutstein, E. (2003). Teaching and learning mathematics for social justice in an urban, Latino school. *Journal for Research in Mathematics Education*, 34(1), 37–73.
- Gutstein, E. & Peterson, B. (2005). Rethinking mathematics: Teaching social justice by the numbers. Rethinking Schools.
- Herodotus (online). Histories. Pekka Mansikka. <https://www.google.com/books/edition/Histories/PnlyEAAAQBAJ?>
- Joseph, G. (1994). The politics of anti-racist mathematics. *European Education*, 26(1), 67–74.
- Khan, S., LaFrance, S., & Tran, H.T.T. (2022). After plantations' precarities: Curating math-thematic curriculum plots in initial teacher education for multispecies' flourishing and a freedom-yet-to-come. *Research in Mathematics Education*, Khan, La France, Tran (2022). After plantations' precarities etc. *Research in Mathematics Education*. <https://doi.org/10.1080/14794802.2022.2090421>
- Klein, R., & Showalter, D. (2012). Where's the math? In J. Díez-Palomar & C. Kanes (Eds.), *Family and community in and out of the classroom: Ways to improve mathematics achievement* (pp. 115–122). Univ. Autònoma de Barcelona.
- Knijnik, G. (2005). Cultural differences, oral mathematics and calculators in a teacher training course of the Brazilian landless movement. *ZDM Zentralblatt für Didaktik der Mathematik*, 37(2), 101–108.
- Knijnik, G. (2007). Mathematics education and the Brazilian landless movement: Three different mathematics in the context of the struggle for social justice. *Philosophy of Mathematics Education Journal*, 21(1), 1–18.
- Knijnik, G., Wanderer, F., & Oliveira, C. J. (2005). Cultural differences, oral mathematics and calculators in a teacher training course of the Brazilian landless movement. *ZDM Zentralblatt für Didaktik der Mathematik*, 37(2), 101–108.
- Kumashiro, K. K. (2009). *Against common sense: Preparing anti-oppressive teachers in six disciplines*. Routledge.
- Lancy, D. (1983). *Cross-cultural studies in cognition and mathematics*. Academic.
- Leonard, J. (2008). *Culturally responsive pedagogy in the mathematics classroom: Strategies for teachers and students*. Routledge.
- Lipka, J., Sharp, N., Adams, B., & Sharp, F. (2007). Creating a third space for authentic biculturalism: Examples from math in a cultural context. *Journal of American Indian Education*, 46(3), 94–115.
- Lorde, A. (1979). The Master's tools will never dismantle the Master's house. In C. Moraga & G. Anzaldúa (Eds.), *This bridge called my back: Writings by radical women of color* (pp. 25–28). Kitchen Table Press.
- Matthews, J. (1989). *Escalante: The best teacher in America*. Henry Holt.
- Moreira, D. (2003). A Matemática na educação familiar: Memórias escolares, ideias sobre a Matemática e relação educativa em grupos domésticos de baixa escolaridade. *Quadrante. Revista de Investigação em Educação Matemática*, XII(2), 3–23.
- Moreira, D., & Pires, G. (2012). O Processo Educativo das Crianças Ciganas e a Aprendizagem da Matemática. Em, Ana Isabel Afonso (Org) *Etnografias com Ciganos*. In *Diferenciação e Resistência Cultural* (pp. 71–87). Edições Colibri.
- Moses, R., & Cobb, C. (2001). *Radical equations: Civil rights from Mississippi to the algebra project*. Beacon Press.
- Mukhopadhyay, S., Powell, A. B., & Frankenstein, M. (2009). An Ethnomathematical perspective on culturally responsive mathematics education. In B. Greer, & S. Mukhopadhyay (Eds.), *Culturally responsive mathematics education* (pp. 65–84). Routledge.
- Naresh, N. (2015). The role of a critical ethnomathematics curriculum in transforming and empowering learners. *Revista Latinoamericana de Etnomatemática*, 8(2), 450–471.
- Orey, D. C., & Rosa, M. (2008). Ethnomathematics and cultural representations: Teaching in highly diverse contexts. *Acta Scientiae*, 10(1), 27–46.
- Orey, D., & Rosa, M. (2011). Ethnomodeling: A pedagogical action for uncovering ethnomathematical practices. *Journal of Mathematical Modelling and Application*, 1(3), 58–67.
- Orey, D. C., & Rosa, M. (2021). Ethnomodelling as a glocalization process of mathematical practices through cultural dynamism. *The Mathematics Enthusiast*, 18(3), 439–468.

- Palhares, P. (2012). Mathematics education and ethnomathematics. A connection in need of reinforcement. *REDIMAT – Journal of Research in Mathematics Education*, 1(1), 79–92.
- Powell, A. B., & Frankenstein, M. (1997). *Ethnomathematics: Challenging eurocentrism in mathematics education*. SUNY Press.
- Presmeg, N. (2007). The role of culture in teaching and learning mathematics. *Second Handbook of Research on Mathematics Teaching and Learning*, 1, 435–458.
- Raum, O. (1938). *Arithmetic in Africa*. Evans Brothers.
- Rosa, M., & Orey, D. C. (2011). Ethnomathematics: The cultural aspects of mathematics. *Revista Latinoamericana de Etnomatemática*, 4(2), 32–54.
- Rosa, M., & Orey, D. C. (2016a). State of the art in Ethnomathematics. In *Current and future perspectives of ethnomathematics as a program* (pp. 11–37). Springer.
- Rosa, M., & Orey, D. (2016b). Ethnomodelling as a globalization process of mathematical practices through cultural dynamism. *The Mathematics Enthusiast*, 18(3), 439–468.
- Said, E. (1978). *Orientalism: Western concepts of the orient*. Pantheon Books.
- Spengler, O. (1918). *The decline of the west in the early 20<sup>th</sup> century*. Oxford.
- Spengler, O. (1956). Meaning of numbers. In J. Newman (Ed.), *The world of mathematics* (pp. 2315–2347). Simon and Schuster, ed. Newman.
- Stathopoulou, C. (2005). *Ethnomathematics: Exploring the cultural dimension of mathematics and of mathematics education*. Atrapos.
- Stathopoulou, C. (2006). Exploring informal mathematics of craftsmen in the designing tradition of ‘Xysta’ at Pyrgi of Chios. *For the Learning of Mathematics*, 26(3), 9–14.
- Stathopoulou, C., & Kalabasis, F. (2002). Teaching mathematics to first grade Romany children, through familiar every day money dealings. In P. Valero & O. Skovsmose (Eds.), *Proceedings of the mathematics education and society conference* (pp. 507–514). Danmarks Paedagogiske Universitet.
- Struik, D. (1948). *A concise history of mathematics*. Dover.
- Swanson, D., & Appelbaum, P. (2012). Refusal as a democratic catalyst for mathematics education development. *Pythagoras*, 33(2), 6 pages. <http://www.pythagoras.org.za/index.php/pythagoras/article/view/189>
- Valero, P., & Stenoft, D. (2010). The ‘post’ move of critical mathematics education. In *Cmathematics education: Past, present and future* (pp. 183–195). Brill Sense.
- Vithal, R., & Skovsmose, O. (1997). The end of innocence: A critique of ‘ethnomathematics’. *Educational Studies in Mathematics*, 34(2), 131–157.
- Walkerdine, V. (1988). *The mastery of reason: Cognitive development and the production of rationality*. Routledge.
- White, L. (1947/1956). The locus of mathematical reality: An anthropological footnote (1947). In J. Newman (Ed.), *The world of mathematics: A small library of the literature of mathematics from A’h Mose the scribe to Albert Einstein* (Vol. 4, pp. 2348–2364). Simon and Schuster.
- White, A. (1993). *Essays in humanistic mathematics*. The Mathematical Association of America (MAA Notes no. 32).
- Whitin, D., & Wilde, S. (1995). *It’s the story that counts: More children’s books for mathematical learning, K-6*. Heinemann.
- Wilder, R. (1950). The cultural basis of mathematics. Plenary address to the international congress of mathematicians, Cambridge, MA, USA, 30 August to 6 September. In *Proceedings of the international congress of mathematicians* (Vol. 1, pp. 258–271) [https://mathshistory.st-andrews.ac.uk/Extras/Cultural\\_Basis\\_I/](https://mathshistory.st-andrews.ac.uk/Extras/Cultural_Basis_I/)
- Wilder, R. (1965). *Introduction to the foundations of mathematics*. Dover Publications
- Wilder, R. L. (1981). *Mathematics as a cultural system*. Pergamon Press.
- Zaslavsky, C. (1993). *Multicultural mathematics: Interdisciplinary cooperative-learning activities*. J. Weston Walch.
- Zaslavsky, C. (1996). *The multicultural math classroom: Bringing in the world*. Heinemann.
- Zaslavsky, C. (1998). *Math games and activities from around the world*. Chicago Review Press.

# Part III

## The Role of History in the Process of Training the Mathematician

### Introduction

Javier Díez-Palomar and Joaquim Giménez Rodríguez  
Department of Didactics of Experimental Science and Mathematics, Faculty of Education, University of Barcelona, Barcelona, Spain

The *Part IV* of this book is devoted to the role of history in the process of training pre-service and in-service teachers of mathematics. The four chapters in this section provide a great example of how we can use the history of mathematics to support teachers in teaching mathematics better. In Vanegas, Giménez, Prat, Palhares, and Gerofsky chapters, the history of mathematics becomes not just a teaching resource but a clear example that mathematics is a cultural product, a part of our human heritage, which contains the challenges, discoveries, difficulties, contributions, that many persons in the past have shared, discussed, and left for us in the present, to continue with. In these four chapters, mathematics is a *living being*, making a case for in-service and pre-service teachers to know the facts of the history of mathematics not just because the history of mathematics provides good examples and anecdotes for the lesson, but because including the history of mathematics in their lessons is a way to make mathematics more humanized, exciting and closer to the students.

We like to go back to Freudenthal's (1977/1981) words about the history and the teaching and learning of mathematics: "should a mathematics teacher know something about mathematics? Or about the mathematics he is teaching? Or about the use of mathematics, about how it is applied (and by that, we do not mean a study of so-called Applied Mathematics)?" (Freudenthal, 1981, p. 30) Those are meaningful and purposeful questions. In middle school, we remember the mathematics textbook, including some taste of mathematics history along the margins of the book, in colourful squares displaying some mathematician's bio or a relevant anecdote

regarding mathematics. I liked those “passages.” However, the teacher did not always pay attention to them, so they usually went unnoticed by us, the students.

Our experience is similar to the one reported by Freudenthal (1981) in his article published more than 40 years ago: the history of mathematics consisted of exciting anecdotes that added “colour” to the mathematics class. But the usual thing is that the opportunity to “humanize” mathematics and make it more interesting was lost (beyond being a bunch of algorithms, rules, procedures, strategies, and concepts, which used to be presented in a decontextualised way most of the time). Would we have learned mathematics with more understanding if the historical narrative had been included in the classroom explanations? This is the question that many of us who are dedicated to teaching mathematics have asked ourselves. This book is an excellent example of that.

There are great textbooks and classroom materials which contextualize the different mathematical objects in their history. Examples that come to my mind are the extraordinary book *Storie di Mathematica* by Prosperini and Isonni (2000) or the book that a group of mathematical enthusiasts discussed and wrote with adults with no formal training (*Matemáticas en las escuelas de Adultos – 1982 –* by Lemos de Castro, Ortega, Flecha, Giménez and Valls), with which the practice of using the history of mathematics as a didactic resource for its teaching was introduced already at the beginning of the 1980s for the first time in Spain (a common practice later on). Research in teacher training has notable examples of this trend, such as Luis Pino-Fan’s thesis, in which the different concepts of the “derivative” are reviewed, drawing on a historical journey about that concept (Pino-Fan et al., 2018). Some textbooks use the history of mathematics as the main organiser for the curriculum.

Previous research has shown that using the history of mathematics positively impacts the motivation to study this topic (Fauvel & Mannen, 2002; Karp & Schubring, 2014). In this book, we can see clear examples of this claim. According to Fauvel (1991), there are (at least) fifteen reasons that have been used to justify using history in mathematics education:

- Helps to increase motivation for learning
- Gives mathematics a human face
- Historical development helps to order the presentation of topics in the curriculum
- Showing pupils how concepts have developed helps their understanding
- Changes pupils’ perceptions of mathematics
- Comparing ancient and modern establishes value of modern techniques
- Helps to develop a multicultural approach
- Provides opportunities for investigations
- Past obstacles to development help to explain what today’s pupils find hard
- Pupils derive comfort from realizing that they are not the only ones with problems
- Encourages quicker learners to look further
- Helps to explain the role of mathematics in society
- Makes mathematics less frightening
- Exploring history helps to sustain your own interest and excitement in mathematics
- Provides opportunity for cross-curricular work with other teachers or subjects (Fauvel, 1991, p. 4)

There are multiple examples of case studies in which the history of mathematics has been used in the classroom as a teaching resource (Fauvel & van Maanen, 2000; Katz, 2000; Shell-Gellasch & Jardine, 2005; Furinghetti et al., 2007; Katz & Tzanakis, 2011). Mathematics students not only appreciate being presented with a more “in-context” view of mathematics, but it also seems that research findings suggest that understanding of mathematics is improved (Liu, 2003), despite that there are authors who show some hesitation towards the replicability (and generalisation) of these cases (Barbin et al., 2020). It seems that presenting mathematical objects in their historical context, justifying why they arose, how they occurred, how they were found, etc., makes it easier to make connections between them.

Now, one thing is that students like teachers to use the history of mathematics to organise and deliver the contents of the curriculum (because this practice motivates them, and they understand the lessons better); and quite another thing is the use of the history of mathematics by teachers. Here what we must discuss is what concept of “using the history of mathematics” teachers have, as Fried (2018) warns, and that we can also guess in the article written by Freudenthal (1981).

Fried (2018) goes back to the works of David Eugene Smith (1860–1944) to distinguish between two ways of using the history of mathematics to teach mathematics. On the one hand, one of the approaches referred to by Fried (2018) is the well-known “drill and practice” method. Paraphrasing Smith (1902), Fried refers to this method of teaching mathematics as that of the “mechanical teacher”, an approach that both he and Smith, at the beginning of the twentieth century, totally rejected as adequate for teaching mathematics.

Opposite to this approach, Fried, following Smith, highlights a more “cultural” approach, which we understand as more “humanized”, more “contextual”, and more related to the history of the construction of mathematical knowledge. By focusing the way of teaching mathematics on the historical-evolutionary aspect of mathematical knowledge, Smith assumes certain parallelism between how mathematical knowledge develops and how children learn said knowledge. The *parallelism argument* can be accepted and understood that just as mathematical objects have emerged because of an evolutionary process of specific discoveries, connections, advances, setbacks, etc., the same happens with students’ learning. It will be easier for students to follow the same “route” that the development of a mathematical object has followed throughout history to understand it. Smith already warned that this does not mean that “the child must go through all the stages of mathematical history -an extreme of the “culture-epoch” theory; but what has bothered the world usually bothers the child, and the way in which the world overcome its difficulties is suggestive of the way in which the child may overcome similar ones in his own development (p. 42–43) (quoted in Fried, 2018, pp. 87–88).

Following the same historical path that mathematical objects have followed in their evolution throughout history can perhaps help some students to contextualise the mathematics that appears in textbooks and to motivate themselves. However, the evidence is not conclusive in this regard. Many works suggest that the “historical” sequencing of concepts (the “logical” epistemic configuration of a mathematical object, in terms of Godino, Font and others -Godino et al., 2007; Font et al., 2013),



does not always coincide with the cognitive learning sequence of every student. For example, what is better to present a sequence and study towards what value it tends? Or choose to take a “historical journey” to the classical Greece of Archimedes, and explain his variant of Eudoxus’s method of exhaustion, the method of compression, to approximate by inscribed and circumscribed polygons respectively a given circumference to the sphere -or the maximum circle- to which this circumference corresponds? Or perhaps explain the concept of  $\varepsilon$  drawing directly on the “modern” definition of the limit of a function  $f(x)$ ? Or maybe draw the representation of a function on the board and take arbitrary values of  $\varepsilon$  so that you can choose a  $\delta$  for each of them, so that  $f(x)$  and  $L$  get closer as  $x$  gets closer to  $c$ ? Or work with the intuitive idea of a function  $f(x)$  whose values approach a certain real number,  $b$ , as the variable approaches the point  $a$ ? or maybe just explain the formulation provided by Cauchy?

According to research such as Fauvel (1991), Furinghetti et al. (2007), or Liu (2003), contextualizing mathematical objects (such as limit) in their historical context serves to motivate students. And we know that motivation is a crucial part of any cognitive learning process, as Mehler and Bever’s (1967) experiment on conservation of quantity showed for young children (around 2 years of age).

On the other hand, Smith (according to the interpretation of Fried, 2018) also considered that teaching mathematics using a historicist approach serves to use the “history of mathematics [...] as a kind of filter allowing one to see clearly what has proven important and fruitful and what turned out to be effete and not worth pursuing.” (Fried, 2018, p. 88) Using history is a strategy to ensure that the mathematics being explained is “good mathematics” because if what the history of mathematics “has preserved” is explained, then the teacher may be reasonably sure that it is explaining something useful and “accepted” by the universal mathematical community (who decides what things are incorporated and remain in history, and what things are forgotten or do not deserve a place in that history). Fried uses this quote from Smith to illustrate this idea of permanence and certainty of mathematical knowledge that is part of universal mathematics.

One thing that mathematics early imparts, unless hindered from so doing, is the idea that here, at last, is an immortality that is seemingly tangible -the immortality of a mathematical law... The laws of the Medes and Persians, unchangeable though they were thought to be, have all perished; the canons that bound Egyptian activities for thousands of years exist only in the ancient records, preserved in our museums of antiquity...But in the midst of all these changes it has ever been true, it is true today, it shall be true in all the future of this earth, and it is equally true throughout the universe whether in the algebra of Flatland or in that of the space in which we live, that  $(a + b)^2 = a^2 + 2ab + b^2$ . (p. 341) (Fried, 2018, p. 88)

Therefore, it seems that the relationship between the history of mathematics and the teaching of mathematics, at least from the point of view of the teacher (and of teacher training), is that history constitutes the driving force of the mathematics curriculum.

This part of the book that you have in your hands now is devoted to bringing the history of mathematics as this “driving force” for teachers of mathematics to design, plan, implement and evaluate their mathematics lessons. The first chapter by Giménez and Díez-Palomar, provides the framework for this section. They go

back to the main approaches in the research conducted in the field of mathematics teachers' training programs, highlighting the challenges and contributions overtime during the last decades, focusing on the Iberic American tradition (that has been less analyzed as the English influence on the field). Giménez and Díez-Palomar review how the training of our in-service and pre-service mathematics teachers has evolved, while the Teacher Mathematics Education (TME) became a research agenda within Mathematics Education (M.E.) as a scientific discipline. They also emphasize the contributions of the Iberic America CIEAEM community to TME programs.

In the following chapter, Vanegas, Giménez, and Prat explore the use of history in enriching mathematics teachers' training programs for primary education. They present history to create "context" for the lessons and, therefore, to increase the students' motivation. Learning mathematics in their historical context has a great potential to engage students in the learning experience. History also provides opportunities to discuss mathematics as a cultural product. The history of mathematics humanizes mathematics, making it more interesting, understandable, and closer to students. Their examples of money systems, or the Liu Hui decompositions, or the case of measurements, are great examples of how to use history to engage students in mathematics learning.

Palhares' chapter is an excellent proposal of using puzzles in the history of mathematics to foster students to solve problems. Previous research has demonstrated the capacity problem-solving situations have to develop students' mathematical abilities. Palhares introduces classic mathematics books inspired by some great mathematicians in the past (such as Luca Pacioli, or Fibonacci), as well as by ancient mathematical documents (e.g., the Rhind papyrus), to discuss several problems as potential situations for teachers to introduce mathematics reasoning to their students.

Gerofsky's chapter brings our attention to the discussion of using the history of mathematics in pre-service teachers' programs. Her proposal (the "History of mathematics for teachers" course) is an excellent example of how creating a course drawing on the cultural heritage of mathematics as a universal set of knowledge. Her proposal pushes us to avoid a *western* image of the history of mathematics (mainly rooted in the ancient Greek tradition), but including other references such as Babylonian, Ancient Egyptian, Mayan, and Incan, mathematics from islanders, China, Japan, the medieval Islam, or the Renaissance in Europe. Her proposal makes us think beyond the history of mathematics as a simple tool for making teaching more "interesting."

In the Freudenthal article *Should a mathematics teacher know something about the history of mathematics?* (which is a version of the lecture he gave at the IREM of Poitiers on June 17th, 1977) Freudenthal (1981) explains that using the history of mathematics to teach mathematics is not "telling stories." It does not mean explaining anecdotes from the history of mathematics in class. It is not explaining stories, such as Hippasus of Metapontus being expelled (or assassinated, according to some) from the Pythagorean school because broking the rule of silence when he discovered the incommensurability of the diagonal of a square with the side of the same square and proved the existence of irrational numbers. That condemned him in the eyes of the rest of the members of the Pythagorean school. Or the famous

anecdote of young Gauss when he devised a way to count the first hundred natural numbers of the arithmetic progression  $S_n = \frac{a_1 + a_n}{2} \times n$ . For Freudenthal the key is that history is at the service of mathematics. He lists several possible examples of this:

- Numbers -where do they come from, what do they point to, what do they mean?
- The numerals and their shapes -could they have been different and why are there ten?
- Why does the day have 24 hours?
- The hour sixty minutes?
- The minute sixty seconds?
- The year 365 days, and sometimes 366?
- The week seven days?
- Snowwhite seven dwarfs?
- The right angle 90 degrees?
- A dozen twelve pieces?
- Why is a meter 100 cm long?
- Why does water boil at 100 centigrades?
- And freeze at zero?
- Why is  $-273^\circ$  the absolute zero?
- Why has the sky four quarters?
- The year four seasons?
- Why is the equator so nicely 40.000 km, and yet a little more?
- The velocity of light so nicely 300.000 km/sec?
- The velocity of sound so nicely 333 m/sec?
- The nautical mile a crazy 1852 m?
- And the statute mile 1609 m?
- Why does a stamp for a domestic letter cost 65 (Dutch) cents?
- Why is  $\pi$  about 3 1/7?
- What is the natural feature of the basis of natural logarithms?
- Why does a man have 32 teeth?
- And a deck of cards 32 or 52 pieces?
- Why are there 9 men in skittles and 10 in bowling?
- Why does February have 28 days? (Freudenthal, 1981, p. 32)

What Freudenthal (1981) proposes is to use the history of mathematics to generate “interesting questions” that lead to connecting relevant facts of everyday life (something very usual in the school of realistic mathematics) with historical aspects related to mathematics, which serve to deepen mathematics and its understanding (and usefulness, together with the cultural and historical context where it appears/is constructed).

We see a similar approach to the one presented by Freudenthal in the chapters that are part of section IV of this book, especially those that correspond to Pedro Palhares and Yuly Vanegas, Joaquín Giménez and Montserrat Moratonas. The cases that are explained about the use of different units of measurement throughout history and in different geographical contexts, the impact on the everyday economy, the use of historical problems such as Lui’s decompositions, the mathematical puzzles that we find in books such as those collected by Palhares (see his chapter in this book) are examples that show the potential of the history of mathematics as a resource for teaching mathematics in the classroom. In addition, Gerofsky’s chapter introduces an example of how to use the history of mathematics in a course of professional teachers’ training at the university.

This impact is not only from the point of view of the resources that the teacher can count on to organize their lessons. We also know that it substantially improves student motivation, as we have already said above. But not only that. Díez-Palomar (2020) shows that using the reading of classic readings of the History of Mathematics helps adults without previous studies or with limited academic training (ISCED levels 0 and 1) to have the opportunity to engage in mathematical conversations, know, understand and use mathematical objects that are part of our knowledge of mathematics. An example is the use of the number base in number systems. Reading the book *Historia de las Matemáticas* [History of Mathematics] by Jean-Paul Collette (1985), the following excerpt can be read (in the chapter on the Babylonian civilisation):

For example, one problem is “to know the length of the side of a square whose area minus the side is equal to 870.” This is equivalent to solving the equation  $x^2 - x = 870$ . How did they solve this problem? Take half of 1, which is 0;30 (in base 60), and multiply 0;30 by 0;30, which is 0;15; this result is added to 14.30 ( $14.30 + 0;15 = 14.30;15$ , since 0;15 means 0.15); but 14,30,15 is the square of 29,30. Finally, 0,30 is added to 29,30 and the result is 30, the side of the square. (Collette, 1985 p. 27)

The women participating in the *dialogic mathematical gathering* were very struck by how the numbers were written (0;30, 14,30;15, etc.) and that the text said that this was “base 60.” A discussion arose about what base means when talking about a number system. I remember that this fragment of Babylonian history led us back to the times when we used the *peseta* before the *euro*. We reflected that before, with the *peseta*, sometimes it was counted in *duros* (which were five *pesetas*). When someone said “twenty *duros*”, in fact, the 20 meant one hundred *pesetas*. In the same way, when in ancient Babylon someone said 1;30 (for example), they meant “once sixty, and thirty more units”, which is a total of 90 units. Using a fragment of the story allowed us to discuss one of the critical aspects of any numbering system, which is the use of grouping as the basis on which units (of a number system) and their multiples are created.

Hence, going back to the initial questions posed by Freudenthal (1981) with which we began this preface, it seems clear that teachers (and teacher training) must integrate the history of mathematics. And this is so not only because it motivates students (knowing, for example, some anecdotes of characters who have made contributions to mathematics). As Fauvel (1991) said, there are at least 15 good reasons to include the history of mathematics in its teaching. Therefore, it is also necessary for teachers to know the history of mathematics (Jankvist, 2009). This should make us reflect on teacher training. In CIEAEM, as Díez-Palomar and Giménez show in their chapter in this book, it is something that has been done for decades. We need to incorporate the history of mathematics into the training programs for future teachers so that teachers have this knowledge, and they can use it in their lessons. But it is not only to include the history of mathematics; it is also necessary to include examples and practical cases of how to use that story in the mathematics classroom. Books like this one, in the context of organisations like CIEAEM, which has spent decades connecting research with the practice of teaching mathematics, are crucial to setting guidelines for the future.

## References

- Barbin, E., Guillemette, D., & Tzanakis, C. (2020). History of mathematics and education. In S. Lerman (Ed.), *Encyclopedia of mathematics education* (2nd ed., pp. 333–342). Springer reference.
- Collette, J. P. (1985). *Historia de las matemáticas*. Siglo XXI.
- Díez-Palomar, J. (2020). Dialogic mathematics gatherings: Encouraging the other women’s critical thinking on numeracy. *ZDM-Math Education*, 52(3), 473–487. <https://doi.org/10.1007/s11858-019-01092-2>
- Fauvel, J. (1991). Using history in mathematics education. *For the learning of Mathematics*, 11(2), 3–6. <https://www.jstor.org/stable/40248010>
- Fauvel, J., & van Maanen, J. (Eds.). (2000). *History in mathematics education – The ICMI study* (New ICMI study series) (Vol. 6). Kluwer.
- Fauvel, J., & van Maanen, J. (Eds.). (2002). *History in mathematics education – The ICMI study* (New ICMI study series) (Vol. 6). Kluwer.
- Font, V., Godino, J. D., & Gallardo, J. (2013). The emergence of objects from mathematical practices. *Educational Studies in Mathematics*, 82(1), 97–124. <https://doi.org/10.1007/s10649-012-9411-0>
- Freudenthal, H. (1981). Should a mathematics teacher know something about the history of mathematics? *For the learning of Mathematics*, 2(1), 30–33.
- Fried, M. N. (2018). History of mathematics, mathematics education, and the liberal arts. In G. Kaiser et al. (Eds.), *Invited lectures from the 13th international congress on mathematical education* (pp. 85–101). Springer.
- Furinghetti, F., Radford, L., & Katz, V. (Eds.). (2007). *The history of mathematics in mathematics education: Theory and practice*. Educational Studies in Mathematics, 66(2), 107–271.
- Godino, J. D., Batanero, C., & Font, V. (2007). The onto-semiotic approach to research in mathematics education. *ZDM-Math Education*, 39(1), 127–135. <https://doi.org/10.1007/s11858-006-0004-1>
- Jankvist, U. T. (2009). A characterization of the “whys” and “hows” of using history in mathematics education. *Educational Studies in Mathematics*, 71(3), 235–261. <https://doi.org/10.1007/s10649-008-9174-9>
- Karp, A., & Schubring, G. (Eds.). (2014). *Handbook on the history of mathematics education*. Springer.
- Katz, V. (Ed.). (2000). *Using history to teach mathematics: An international perspective* (MAA notes) (Vol. 51). The Mathematical Association of America.
- Katz, V., & Tzanakis, C. (Eds.). (2011). *Recent developments on introducing a historical dimension in mathematics education* (MAA notes) (Vol. 78). The Mathematical Association of America.
- Lesmos de Castro, L., Ortega, M. A., Flecha, R., Giménez, F., & Valls, R. (1982). *Las matemáticas en las escuelas de adultos*. El Roure.
- Liu, P. H. (2003). Connecting research to teaching: Do teachers need to incorporate the history of mathematics in their teaching? *The Mathematics Teacher*, 96(6), 416–421.

- Mehler, J., & Bever, T. G. (1967). Cognitive capacity of very young children. *Science*, 158(3797), 141–142.
- Pino-Fan, L. R., Godino, J. D., & Font, V. (2018). Assessing key epistemic features of didactic-mathematical knowledge of prospective teachers: The case of the derivative. *Journal of Mathematics Teacher Education*, 21(1), 63–94. <https://doi.org/10.1007/s10857-016-9349-8>
- Prosperini, L., & Isonni, B. (2000). *Storie di matematica*. Ghisetti e Corvi Editori.
- Shell-Gellasch, A., & Jardine, D. (Eds.). (2005). *From calculus to computers: Using the last 200 years of mathematics history in the classroom* (MAA notes) (Vol. 68). The Mathematical Association of America.
- Smith, D. E. (1902). *The teaching of elementary mathematics*. The Macmillan Company.

# Chapter 9

## Problems and Puzzles in History of Mathematics



Pedro Palhares

**Abstract** Since the publication of Polya's book *How to Solve it*, and in special after becoming a central aspect of curricular recommendations, problem solving has become a focus in mathematics education. However, mathematical problems as a way to teach mathematical concepts and procedures has been around for many years before that. In this chapter, I will try to present problems and puzzles with an historic background, together with its cultural diversity and intercultural exchanges.

**Keywords** Problem solving · Mathematical puzzles · Mathematics curriculum · History of mathematics education

### Introduction

George Pólya was a Hungarian-born mathematician, who worked in Switzerland from 1914 to 1940. Due to the persecution of Jews in the 1930s in Germany, fearing his situation, he emigrated to the United States, where he lived for the rest of his life (he died in 1985). Polya produced a monumental corpus of work in various fields of Mathematics; however, his name is best known in the Mathematics Education community because of his books on problem solving, in particular the book, *How to Solve it* (Pólya, 1957).

Although he was not the first mathematics educator to propose the introduction of problem solving in the School, George Pólya was undoubtedly the most influential and the most cited; his model of how to solve problems was the basis for all subsequent models; and his books continue to provide powerful sources of reasons to teach problem-solving. He thought that one of the essential tasks of teaching, perhaps the most important, was to pass on general knowledge. And so, when teaching problem solving in math class, the teacher has an excellent opportunity to develop certain concepts and habits of thought that, according to him, were

---

P. Palhares (✉)

CIEC, Institute of Education, University of Minho, Braga, Portugal

e-mail: [palhares@ie.uminho.pt](mailto:palhares@ie.uminho.pt)

important ingredients of general culture beyond the specific mathematics content of a lesson.

Charles and Lester (1986) have considered 5 types of problems: one-step, two or more steps, process, application and puzzle. One-step and two or more steps include the typical school word problems that, if abused, may constitute exercises. Application problems usually arise from real situations, sometimes ill-defined. Process problems are those that require the use of one or more strategies (trial and error, working backwards, table or organized list, identification of patterns, drawing, among others). Puzzles are those problems that only through some insight we can manage to solve.

Some authors (e.g. Appelbaum & Allen, 2008) do consider a distinction between problems and puzzles. In problems we use strategies, mathematical operations, and usually the most important learning occurs while solving them, the solution is not really relevant. In puzzles, the solution is predetermined, we can try out, a few times get lucky, most of the times we get stuck, and it is intuition or insight that lead us to the solution. It is in this sense that we use the terms problems and puzzles.

## **Problem Solving in Mathematics Teaching Curricula**

In the last 40 years the idea of introducing problem solving in schools has progressively become consensual throughout the world. Teachers were pressured by mathematics education researchers and curriculum planners to introduce problem-solving tasks into the classroom.

One very important document was NCTM's 'Agenda for Action' (1980), which suggested problem solving should be the focus of school mathematics in North America. The Cockcroft report (in Desforges & Cockburn, 1987) also included problem-solving tasks as a recommendation for teachers in the United Kingdom. There it was recommended that mathematics teaching include opportunities for lectures, discussion between teacher and students and among students, appropriate practical work, consolidation and practice of fundamental skills and routines, problem solving including the application of mathematics to everyday situations, and investigative work.

After that, the National Council of Supervisors of Mathematics in the United States ranked problem solving as one of the 12 essential components of mathematics education. There it was said that learning to solve problems is the main reason for studying mathematics (NCSM, 1989).

Despite the few sources mentioned above, problem solving then became an international movement, permeating curricula almost everywhere.



## Problem Solving in Schools

Problem solving has been a focus of research in school mathematics education for decades. Researchers agree that it is better for students to learn new mathematical concepts by trying to solve problems on their own rather than by imitating the work of others. Despite this consensus, however, there have been challenges to the implementation of this strategy, and often the resistance comes from the teachers themselves who tend to teach as they themselves have been taught, namely with a lot of exercise practice. Baniower et al. (2018) report that 85% of teachers believe that students should learn mathematics by solving problems themselves and that students should be able to explain their solutions. However, most teachers do not give this opportunity to students, and less than a quarter of classrooms make independent problem solving and discussion a part of daily lessons, which is the exception rather than the norm. The truth is that many teachers are reluctant to change the way of teaching they have learned, perhaps even because they are not prepared to do so.

Examples of problem solving experiences reduced in everyday practice to routine exercises can be found as early as the last century, but extend to the present day. The general structure of this interpretation, according to Schoenfeld (1992), is:

1. a task is used to introduce a technique;
2. the technique is illustrated;
3. more tasks are introduced so that the student can practice the technique.

The basic assumptions are:

1. having worked on this group of exercises, students have one more technique in their math toolbox;
2. the sum of these techniques (the curriculum) reflects the body of mathematics that the student is expected to master;
3. the set of techniques that the student masters is the student's mathematical knowledge and understanding.

Pólya considered that there were two ways of looking at the teaching of mathematics: one, with a concern to train students in routine operations, which had the consequences of eliminating their interest and harming their intellectual development; the other, with the concern of challenging students' curiosity through problems within their reach, and which allows them to develop independent thinking (Pólya, 1957).

## New Justifications for Problem Solving

Arriving here we have to ask: How can we teach students to attack problems using mathematical reasoning if we only give them opportunities to memorize formulas and facts? The most important benefit of studying mathematics is to learn

mathematical processes, such as mathematical reasoning and problem solving. That gives students an opportunity to explore and make sense of the world around them. However, asking students simply to memorize facts and procedures – the results of other people’s exploration and discovery, makes mathematics boring (Takahashi, 2021).

We have to teach students to think mathematically. Thinking mathematically has five interconnected proficiency strands (NRC, 2001):

Conceptual understanding – understanding of mathematical concepts, operations and relationships;

Procedural fluency – ability to carry out procedures properly, with flexibility, precision and efficiency;

Strategic competence – Ability to formulate, represent and solve mathematical problems;

Adaptive reasoning – ability for logical thinking, reflection, explanation and justification;

Productive disposition – Habitual inclination to see mathematics as practical, useful and worthwhile, accompanied by a belief in perseverance and self-efficacy.

However, the expository method and the repetition routine cannot feed the five strands of proficiency.

As we have seen before, many teachers tend to teach the way they were taught (Baran et al., 2011; Mapolelo & Akinsola, 2015). Considering the importance of teaching students to think mathematically, mathematics teacher educators should make an effort to give future teachers the opportunity to solve interesting problems as well as leading discussions on the introduction of problem solving in mathematics teaching. With that kind of experience, they might in the future develop more than just the expository method and the repetition routine.

## **Different Perspectives on Mathematics Teaching**

Almost anyone is familiar nowadays with the notion that there are different perspectives on how to teach mathematics. In the twentieth century, there were several reform movements and subsequent clashes among the various camps involved. Over recent years in the United States, for example, there has been a ‘battle’ between those implementing NCTM reform views and those supporting a ‘back to basics’ transition.

Also well known, is what has come to be called in the literature and public media the ‘math wars’, between some from the community of professional mathematicians and the mathematics educators who promote reforms. Another country with a similar history is Portugal, in Europe, where a right-wing government pushed for a new, more abstract curriculum stripped of problem solving, also, like in the United States, with the support of the mathematics community.

Such recent clashes mirror clashes between the Socratic movement and the Sophists in the time of Plato. Most understood in contemporary educational studies is the Socratic point of view, which emphasized the teaching and learning of ethics, but eventually turned to teaching mathematics, in a dialogue in the *Meno*.

We have found what must have been one of such clashes on mathematics education in Portugal in the sixteenth century. We will describe in some detail how we got to that conclusion and what we believe to be the characteristics of each side, through the analysis of two popular arithmetic books of the same period.

Arithmetic in the middle ages was a major topic of study. However, Swetz (1987) says that in the middle of the thirteenth century, in the European universities, the Hindu-Arabic numeration system was taught, yet the level of teaching was rather theoretical and without practical applications.

As to the first arithmetic books in Europe, Swetz (1987) reports that

The first printed, dated, arithmetic in Germany, appeared in 1482; in France and Spain, 1512; in Portugal, 1519, and in England, 1537. All of these arithmetics were of a commercial type and many were written by reckoning masters (p.24).

Concerning the first Portuguese book, Swetz (1987) claims that

Practical necessity was the motivating force in this printing decision, as indicated by the words of Gaspar Nicolas, the author of the 1519 Portuguese book, in his dedication: "I am printing this arithmetic because it is a thing so necessary in Portugal for transactions with the merchants of India, Persia, Arabia, Ethiopia, and other places discovered by us. (p.25)

## First Book – Gaspar Nicolas Book – 1519

This was the first mathematics book ever printed in Portuguese, and a very popular book in its time, demonstrated by its frequent reprints, in 1530, 1541, 1551, 1573, 1594, and again in the XVII and XVIII centuries (1607, 1613, 1679, 1716). However, during the period from 1472 to 1519, there were about forty arithmetic treatises published in Portugal, either in Latin or in other, common, languages (most often Italian). Nicolas had been inspired by Luca Pacioli's *Suma de Arithmetica, Geometria, Proportioni e Proportionalita*, as he himself reveals in fol. 51 and 55. The great popularity of Nicolas' treatise is generally attributed to the style of its presentation (with a lot of problems with the solutions) as well as to the reputation the author enjoyed at the time (Albuquerque, 1963).

The general organization of the book consists of an initial, brief summary of the basic contents for about 15 pages; then the remainder of the book is presents problems followed by solutions, sometimes with two different methods. Typically, there is a problem of one type, then another with one small variation, and then yet another with a greater variation. After all the themes have thus been explored, there is an array of varied problems to be solved, again with the solution(s) following each problem. The problems are sometimes of a practical nature, at other times related to an imagined and possibly unrealistic story.

To better understand the general organization of the book, let us analyse the initial set of problems. The first twelve problems are clearly meant to introduce a method to solve problems. Nicolas calls this method opposition, and in reality, it is a false position method. Let's be more specific, this is the first problem (reais is the plural of the monetary unit of that time, the real, Lisboa, Sacavem, Vila Franca and Santarem are Portuguese names for Lisbon and three places up to 50 miles from Lisbon):

A man departed from Lisboa to Santarem and we don't know how much money he was carrying. But we know that in Sacavem he doubled his money and then spent 20 reais and he kept money with him. He went to Vila Franca and doubled the money he had and spent 20 reais and he kept money with him. When he got to Santarem he doubled his money and spent 20 reais. Now he has no more money. So, I ask how much money he was carrying.

He then gives two methods to solve the problem; one is the method of opposition, the other is referred to as 'just another rule':

There is another rule as you see below. But I will use opposition for you to understand. Take 18, (...) you will have 4 left. Take 17, (...), you will have 4 missing. Add 4 left and 4 missing which is 8 (broken)

$$\text{Then } 4 \times 18 = 72$$

$$4 \times 17 = 68$$

$$72 + 68 = 140$$

divide 140 by the broken, 8, that gives  $17 \frac{1}{2}$

take  $17 \frac{1}{2}$ , (...) you will have 0 left.

He then gives this other rule

*Another way of doing without opposition:*

For each time he doubles and spends 20, take half of 20, then half of the half, then half of the half of the half, and so on.

$$\text{So, } 20:2 = 10$$

$$10:2 = 5$$

$$5:2 = 2 \frac{1}{2}$$

$10 + 5 + 2 \frac{1}{2} = 17 \frac{1}{2}$  The next problem is not much different from the first in structure. Only the amount of money to be subtracted is changed, from 20 to 12.

However, the context is very different:

I say that a man got into a church and we don't know how much money he was carrying. And he told to the first saint to double his money and he would give him 12 reais. The saint doubled and he gave 12 reais and he stood with money. He went to another saint and told him to double his money, he would give him 12 reais. The saint doubled and the man gave him 12 and he stood with money. He went to another saint and told him to double his money, he would give him 12 reais. The saint doubled, he gave him 12 reais and he got without money. Now I ask how much money this good man carried.

He still solves the problem by the two different methods, opposition and the other rule (today we would likely solve this problem using the strategy, 'working backward').

The third problem is now quite different structurally. The context follows the first one. Now the value to be subtracted is different each time, and therefore the ‘other method’ no longer works (Setubal is a city 40 miles apart from Lisbon):

A man goes from Lisboa to Setubal and he carried some money but we don’t know how much. But we know that in the first sale he doubled his money and spent 12 reais. He stood with some money, which he doubled on the next sale and spent 13 reais. He stood with some money, which he doubled on the next sale, he spent 14 reais and stood with no money. Now I ask with how much money did the good man leave from Lisbon.

Nicolas gives another, fourth problem, not much different from the third, except that the final part of the problem (when the character stays without any money) changes as well:

A man goes from Lisboa to Belem and he carried some money, we don’t know how much. On the sale in Santos, he doubled his money and spent 10. He stood with money. In Alcantara he doubled his money and spent 10. He stood with money. In Belem he doubled his money and spent 12. He stood with 3 reais. Now I ask how much money did this man have.

He then gives a series of three problems with minor variations, and absent any context except the numerical one, specifically to be solved with opposition:

Make from 20 two such parts that a fourth of one over the other is 17.

Make from 20 two such parts that  $\frac{1}{3}$  of one over the other makes 18.

Make from 20 two such parts that a fourth of one over the other makes 12.

He then proceeds with a series of five problems, all with the same context, three men wanting to buy something. They dialogue with one another, stating which part of the others’ money would be enough to buy the property in question (cruzados is the plural of one monetary unit of the time):

I say that three men want to buy a horse that is worth 60 cruzados and said the first to the second if you give me the half of yours with what I have I will buy that horse. Said the second to the third but give me one third of yours with what I have I will buy that horse. Said the third to the first but you give me one fourth of what you have with what I have I will buy that horse. Now I ask how much each had in their purses.

He then changes horse for house and 60 cruzados for 79 to create the second problem. For the third problem, he changes house for thing. Besides that, we no longer know the value of the thing, and, now it is half, third and fourth of what the other two men have. For the fourth problem, the only change is that half, third and fourth are substituted by third, fourth and fifth. In the fifth gets back to half, third and fourth of what the other two have but now we have the value obtained, 30:

Three men have money said the first to the two give me you to me the half of yours and with what I have, I will have 30. Said the second to the other two but give me you to me the third of yours and with what I have I will have 30. Said the third to the other give me you to me the fourth of yours and with what I have I will have 30. So, I ask how much each one has.

He takes two whole pages to explain the solution to this last problem, and the values are indeed complicated to find.

In summary, for this particular method he is expounding, he has three sets of problems of different nature, and within each set he varies the problems so as to generate more complicated ones that are also designed to give the opportunity to extract some generality. Some rules apply always, some don't; sometimes you get whole numbers, at other times you get fractions, and so on.

He then continues with the theme of progressions, with 8 arithmetic and geometric progressions (up to a point, it's not infinite) to get their sum. After that is bartering (4 problems), numbers (26 problems, starting with "Give me such two numbers that makes the same a quarter and a fifth of one as a fifth and a sixth of other"), then some weighing and selling of goods, and so on. There are a total of more than 150 problems each with an explicated solution.

## Second Book – Rui Mendes – 1541

As with Nicolas' book, Mendes begins with an introduction, a long explanation of all of the contents of the book without any problem or exercise being given (104 pages up to square and cubic roots extraction). The book has a very organized index, with chapters, parts and particles. It has an encyclopaedic nature; the organization falls into small bits, and classifies all possibilities, and has a pedagogical/psychological import of a large number of cases. Eventually, the author proceeds by exhaustion in some cases (division of 324 by 2, 3, 4, 5, . . . , 8). One might say it tries to break complexity into simple steps, but that the result is a stripping of content.

In order to better understand this book's philosophy, we should look first into the contents index. There we can see in the beginning:

The present book contains seven treatises and each treatise has seven chapters. And each chapter certain particles. In the first treatise are declared the seven parts of the art of arithmetic by whole numbers – denominate: sum: diminish: multiply. Share. Progression. Take square and cubic roots with all the necessary.

This first treatise has about 32 folios (64 pages). On the whole of these 64 pages there are no problems or exercises, consisting of an explanation of the several things involved, including the algorithms. But perhaps we should analyse in more detail what the author is doing:

It follows the second chapter in which I will declare the second sort, which is called summing: which chapter has nine particles. This first particle has the declaration of the said sort. At first I will say like this: that summing is not another thing than gathering many numbers in one only or in many and knowing what to amount in all. And I say in only one because of the first way of summing that I will declare ahead and which is the most universal: in which always the numbers get together in only one. And I say more in many because of the second way of summing that I declare ahead in which the numbers sometimes get together in only one: however, most times will get together in other many. This way is not so universal as the first. And for that reason, this sort is called summing because through it those numbers are gathered as it is said: because summing means gathering. (Folio 4)

It is clearly a style in which everything is split into the smallest possible parts. And each little bit is explained in great detail, even if sometimes in circular reasoning, for example in the case of explaining why one should call the operation ‘summing’: because it is gathering, and gathering is summing.

Another interesting aspect of this book is its use of variation, apparently implemented in order to exhaust the possibilities. Let us continue with sum in the book. So far the author has explained the name, the concept, and has said that there two ways of adding, one that results in one number, and another that usually results in one number but not always. Let us see how he develops this idea:

Particle second – Being so declared what is summing and why it is called that way. You should know that there are two ways of summing. The first is when the number we want to sum are all of the same quality. (...) This way is much more universal than the second. Which is when the numbers we want to sum are not of the same quality, instead of many, as some were of the quality of *cruzados* and some of *tostoes* and some of *vintens* and like this for other kinds of coin. Or some of the quality of *quintais* and some of *arrobas* and some of *arrateis* and like this for other kinds of weight. Or some of *varas* and some of half *varas* or some of *varas* and some of thirds. Or some of *alqueires* and some of halves and some of fourths and like this of other qualities of measurement or of any other things (Folio 4)

So far we have established five major distinctions between these two books:

1. Knowledge to be constructed by solving problems versus knowledge to be imparted in words.
2. Knowledge is connected, not partitioned, versus knowledge is partitioned into small bits.
3. Variation has a pedagogical objective versus variation has an exhaustion purpose.
4. The organization is established for methods and for each method a few different sorts of applications, versus the organization is for contents and for each major content minor contents will be sought.
5. Learning how to solve realistic problems is the drive, versus learning how to perform calculations with numbers.

## Cultural Diversity and Intercultural Exchanges

Mathematics since antiquity has been accompanied by a register of problems, sometimes solved just for fun, sometimes intended to facilitate learning; often both purposes are combined, since it is by solving problems that we sharpen our wits and whet our ingenuity (Kasner & Newman, 1988).

The first source of problems lies in what is known as the Rhind papyrus, which takes us back to the Egyptian civilization. Here is an example taken from this ancient text:

Problem 79 from the Rhind Papyrus (c. 1650 BC; Chace et al., 1927)

There are seven houses, each with seven cats. Each cat kills seven mice and each mouse eats seven cobs of wheat. Each cob of wheat would have produced seven hekats of grain. What is the total of all this?

This problem points to multiplying 7 by itself 5 times. Despite the big dimension of the final result, nowadays it would not be considered a problem, given our calculation skills, even if only by the use of a calculator. In the time of the Egyptian civilization, on the other hand, as they didn't use multiplication by seven directly, they would have to double, double again and add with the original number. As we have multiple multiplications by 7, this would have to be done several times.

$$7 \times 7 = 7 + 14 + 28 = 49$$

$$49 \times 7 = 49 + 98 + 196 = 343$$

$$343 \times 7 = 343 + 686 + 1372 = 2401$$

$$2401 \times 7 = 2401 + 4802 + 9604 = 16807$$

Finally, as you seek the total of all of this, you would have to add the various products found.

$$7 + 49 + 343 + 2401 + 16807 = 19607$$

Nowadays, with our algorithms or even with a calculator, we would solve it in an instant. But in ancient Egyptian it must have been something very difficult, and not only that, but a way to learn how to multiply with the Egyptian algorithm.

This problem has been reformulated many times throughout history, with its specific characteristics altered in one way or another, and often with its purpose modified. Let us look at the problem articulated by Fibonacci in his *Liber Abaci* (Wells, 1992):

Seven old women are travelling to Rome, and each has seven mules. On each mule there are seven sacks, in each sack there are seven loaves of bread, in each loaf there are seven knives, and each knife has seven sheaths. The question is to find the total of all of them.

This is essentially the same problem, but with one more level, as 7 ends up being multiplied 6 times and not 5 as in the previous one. Fibonacci's purpose was to show that the Roman numerals then used were of little use, the Arabic (originally Hindu) numerals being better. We have to recognize that doing all these multiplications and then the final addition using the abacus would have been an almost impossible task.

In eighteenth century Victorian England, a statement based on a series of multiplications and additions was uninteresting, so here's how the problem turned out to be changed:

As I was going to Saint Ives,

I met a man with seven wives.

Every wife had seven sacks.

Every sack had seven cats.

Every cat had seven kits;

Kits, cats, sacks and wives.

How many were there going to Saint Ives? (Chace et al., 1927)



In this puzzle, attention to the statements and the story being told is more important than the calculations, which are totally irrelevant. In the end, only one is going to Saint Ives. . . Considering the first problem, then the second and finally the third, there were first incremental modifications but then a structural modification. All original and subsequently modified problems had educational intent, yet this changed each time.

A very important source of problems and puzzles from the ninth century is the book by Alcuin of York, who lived and taught in Charles Magne court. We will take two puzzles from it.

Three friends, each with a sister, needed to cross a river. Each one of them coveted the sister of another. At the river they found only a small boat, in which only two of them could cross at a time. How did they cross the river without any of the women being defiled by the men? (Hadley & Singmaster, 1992, p. 111).

This is a puzzle whose context could be problematic today, since it is based on sex discrimination. It was however studied by many, who considered small changes like 4 couples instead of three (impossible, but Tartaglia gave an erroneous solution), with 4 couples with a 3-person boat, or with an island in the middle of the river, and with  $n$  bigger than 4 couples. (Hadley & Singmaster, 1992). Particularly interesting is a variation that appears in a 1624 book, in which there are three masters and three valets, and the masters hate the other valets and will beat them if left alone with them. Instead of sex discrimination, we have class discrimination! A later modification assumed masters and valets as well, but the valets are thieves and will rob the masters whenever they find themselves outnumbering the masters. This makes a small difference for the solution since the connection between any master and his valet is no longer an important detail. It is however still based on class discrimination of a different kind; lower classes are presumed to be robbers whenever they have the opportunity. There is a variation in which we have missionaries and cannibals. Cannibals who outnumber the missionaries will eat them! (Pressman & Singmaster, 1989). This is again a repulsive idea of white men being morally superior but having to be smart to counter the civilizational deficit of other, less advanced cultures. It is interesting how this initial puzzle from Alcuin was pursued by so many, who changed it in so many ways, some changing the solution or the solving process, others just changing the context. More interesting is that, from today's perspective, all these variations and the original puzzle carry hidden messages that we today find, at the very least, inappropriate.

One other puzzle from Alcuin's book is this:

A man had to take a wolf, a goat and a bunch of cabbages across a river. The only boat he could find could only take two of them at a time. But he had been ordered to transfer all of these to the other side in good condition. How could this be done? (Hadley & Singmaster, 1992, p. 112).

This is a very interesting educational puzzle that happened to be studied by none other than Piaget, with children of several ages. Piaget (1978) presented it to children, introducing, as a simplification, a boat on the other bank, and introducing the question, 'What if it were the goat instead of the wolf (or cabbage)?' as an

unlocking aid. As a complement, if children managed to solve it, he asked them to think about how the traveler could return to the shore from which he had started. He found 5 levels in the children's responses. At sub-stage IA (5–6 years old) no child understands the need to start everything with the transport of the goat, nor does he or she spontaneously have the idea of bringing the goat when they take the wolf (or cabbage) on the second outward journey. Solutions not foreseen in the conditions are also common: putting up a barrier, giving the wolf or goat other food or making the boat go so fast that the animals don't have time to eat. At this level, children focus their attention on a single incompatibility or compatibility (wolf and cabbage), forgetting the others. At sub-stage IB (6 years old and several 7-year-olds) the intention to coordinate begins, but without success, although with the clear purpose of achieving compatibility (wolf/goat). The return of the cabbage is discovered spontaneously, but it is not seen as a necessary condition, experienced rather as a one-off. In substage IIA (7–8 years), which is characterized by the beginning of the coordination of incompatibilities and compatibilities, although compatibility (wolf and cabbage) takes precedence and causes wrong attempts, each child eventually concludes with the need to start with the goat, except for the inverse problem, which seems like a new problem to them. In sub-stage IIB (9–10 years old), children solve the problem but either start with the wolf or cabbage until they are convinced of the need to start with the goat, or in the inverse problem, they start with the wolf or cabbage; or, after solving the problem, they draw lessons from failed attempts rather than from the solution. In stage III (10–12 years) there is simultaneous and complete coordination of meetings and separations in both problems (Piaget, 1978).

From what can be perceived after the rather thorough study by Piaget, this is a very interesting problem to be given to elementary children. There are some different versions of this puzzle, but with the same exact structure. Hadley and Singmaster (1992) mention a variation with a fox, duck and grain. This one is from Liberia:

A man has a leopard, a goat, and a bundle of cassava leaves. He must get them all across the river, but his boat can carry only one object besides the man himself. If he leaves the goat with the leopard, the goat will soon be eaten. He cannot leave the goat with the cassava leaves because the goat will make a meal of them. What is the fewest number of trips that the man must make to get all three objects across the river? (Zaslavsky, 1998, p. 81).

Zaslavsky (1998) mentions a variant with a different solution, told by African Americans living in the Sea Islands of South Carolina:

Jonah stood on the bank of the river and wondered what to do. Next to him stood a fox. Nearby was a duck and a bag of corn. He had to row them across the river before nightfall. But his boat was too small to hold everything. It could carry only two things besides Jonah.

Jonah would have to leave one thing behind. But if he left the fox with the duck on the other side of the river, the fox would soon make a meal of the bird. He couldn't leave the duck with the corn because the duck would eat the corn.

Jonah knew that he must make more than one trip. How could he get the fox, the duck, and the corn across the river safely? (Zaslavsky, 1998, p. 79)

As one can see, in this case the boat can carry two besides the man. There are fewer travels and it is easier to find one solution, even if it can be claimed that there is a better solution than the others. We could take the fox and duck, return with the duck

and then carry the duck and corn. But that means the duck would have to travel continuously back and forth, with extra effort by the rower. Perhaps, then, it is better to carry the fox and corn and return empty to then take the duck.

Ascher (1990) believes that the two versions, one with only one possession traveling with the rower and the other with two possessions, were developed independently, one in Europe and parts of Africa, while the second spread only in Africa. She claims that “Attention to logic, (. . .), is not the exclusive province of any one culture or subculture. (. . .) the river-crossing problem, (. . .) [is] an explicit example of the panhuman concern for mathematical ideas.”

So, there are a few ideas we can extract in this section about problems:

1. Problems are spread across cultures;
2. They are adapted from one culture to another;
3. Adaptation of a problem can result from an educational aim, or from a need to contextualize it in the particular culture;
4. Sometimes problems will bring forth elements of a culture that are not acceptable by another;

## Final Considerations

Problem solving, as a strong recommendation in mathematics education, has been around for sixty years, since the NCTM’s ‘Agenda for Action’ (1980). But as we have shown, problems and puzzles have been accompanying mathematics education, in its varied forms, for several millennia, at the very least since the writing of the Rhind Papyrus.

Problems and puzzles are not the mark of any sole civilization, they can be traced in many civilizations and time periods. In some periods, one type of problem or puzzle is the preferred, in a different time or place it is another type the preferred, many times depending on the educational purpose intended.

Problems and puzzles are adapted to people’s culture, knowledge, or environment they live in, and sometimes express one particular culture bias toward women, or low classes, or foreigners. These biases should be reckoned and avoided in education settings.

To finish these considerations, we must stress their importance for mathematics teacher education. Future teachers should be empowered on sources of good problems, their connection to mathematics history, and of course the skill to change them whenever necessary.

**Acknowledgements** This work was financially supported by Portuguese national funds through the FCT (Foundation for Science and Technology) within the framework of the CIEC (Research Center for Child Studies of the University of Minho) projects under the references UIDB/00317/2020 and UIDP/00317/2020.

## References

- Albuquerque, L. M. (1963). Notas sobre a obra e o seu autor. In G. Nicholas (Ed.), *Tratado da Prática Darismética* (Edições Fac-Similadas). Livraria Civilização.
- Appelbaum, P., & Allen, D. S. (2008). *Embracing mathematics: On becoming a teacher and changing with mathematics*. Routledge.
- Ascher, M. (1990). A river-crossing problem in a cross-cultural perspective. *Mathematics Magazine*, 63(1), 26–29.
- Banilower, E. R., Smith, P. S., Malzahn, K. A., Plumley, C. L., Gordon, E. M., & Hayes, M. L. (2018). *Report of the 2018 NSSME+*. Retrieved from <https://eric.ed.gov/?id=ED598121>
- Baran, E., Chuang, H., & Thompson, A. (2011, October). TPACK: An emerging research and development tool for teacher educators. *TOJET: The Turkish Online Journal of Educational Technology*, 10(4), 370–377.
- Chace, A. B., Manning, H. P., & Archibald, R. C. (1927). *The Rhind mathematical papyrus. Photographic facsimile, hieroglyphic transcription, transliteration, literal translation, free translation, mathematical commentary, and bibliography* (Vol. 1). Mathematical Association of America – via Internet Archive.
- Charles, R., & Lester, F. (1986). *Mathematical problem solving*. Learning Institute.
- Desforges, C. W., & Cockburn, A. D. (1987). *Understanding the mathematics teacher: A study of practice in the first school*. Falmer Press.
- Hadley, J., & Singmaster, D. (1992). Problems to sharpen the young. *The Mathematical Gazette*, 76(475), 102–126. The Use of the History of Mathematics in the Teaching of Mathematics (Mar., 1992), (25 pages).
- Kasner, E., & Newman, J. R. (1988). Pastimes of past and present times. In J. R. Newman (Ed.), *The world of mathematics – a small library of the literature of mathematics from A'h-mosé the scribe to Albert Einstein* (pp. 2393–2414). Tempus Books.
- Mapolelo, D. C., & Akinsola, M. K. (2015). Preparation of mathematics teachers: lessons from review of literature on teachers' knowledge, beliefs, and teacher education. *International Journal of Educational Studies*, 2(01), 1–12.
- National Council of Supervisors of Mathematics. (1989). Essential mathematics for the twenty-first century: The position of the National Council of supervisors of mathematics. *Arithmetic Teacher*, 44–46.
- National Council of Teachers of Mathematics. (1980). *An agenda for action: Recommendations for school mathematics of the 1980s*. Author.
- National Research Council. (2001). *Adding it up: Helping children learn mathematics*. National Academy Press.
- Piaget, J. (1978). *Investigaciones sobre la contradicción*. Siglo Veintiuno.
- Pólya, G. (1957). *How to solve it*. Anchor Books.
- Pressman, I., & Singmaster, D. (1989). “The jealous husbands” and the “missionaries and cannibals”. *The Mathematical Gazette*, 73(464), 73–81.
- Schoenfeld, A. (1992). Learning to think mathematically: Problem solving, metacognition, and sense making in mathematics. In D. A. Grouws (Ed.), *Handbook of research on mathematics teaching and learning* (pp. 165–197). Macmillan.
- Swetz, F. J. (1987). *Capitalism and arithmetic: The “new math” of the 15<sup>th</sup> century including the full translation of the Treviso arithmetic of 1478*, translated by David Eugene Smith. Open Court.
- Takahashi, A. (2021). *Teaching mathematics through problem solving: A pedagogical approach from Japan*. Routledge.
- Wells, D. (1992). *The penguin book of curious and interesting puzzles*. Penguin Books.
- Zaslavsky, C. (1998). *Math games & activities from around the world*. Chicago Review Press.

# Chapter 10

## The Potential in Teaching the History of Mathematics to Pre-service Secondary School Teachers



Susan Gerofsky

**Abstract** This chapter explores the development and student uptake of a five-year-old course in “History of Mathematics for Teachers” as part of a secondary teacher education program. In the design of this 13-week course, choices had to be made about which aspects, eras and cultures’ history of mathematics to include, what pedagogies to use to engage future secondary teachers with math history in meaningful ways, what the ‘big picture’ message(s) and take-aways might be from this course (i.e., the pedagogical intentions of the course), which resources could be drawn on to bring these intentions to reality. Once the instructor had made these design decisions, and made a series of mid-course adjustments to adapt to student requests and suggestions, there remains the question of student uptake of these intentions and design decisions. Were the intentions understood by learners, and were they effective in promoting an attention to historic consciousness, diversity in many dimensions, and to supporting new teachers’ flexible thinking and design approaches for their own teaching? Course syllabi, blog posts and student writing are used to explore these questions in presenting this particular course as a case study for further work on inclusion of the history of mathematics for diversity in teacher education.

**Keywords** History of mathematics · Teacher education · Secondary mathematics curriculum · Mathematical communication · Teacher knowledge

### Introduction/Context

This chapter is largely based on my experiences of designing, teaching and redesigning a course on the history of mathematics for teachers in the teacher education program in my university in Vancouver, Canada, on Canada’s Pacific

---

S. Gerofsky (✉)

Department of Curriculum & Pedagogy, The University of British Columbia,  
Vancouver, BC, Canada

e-mail: [susan.gerofsky@ubc.ca](mailto:susan.gerofsky@ubc.ca)

coast. Vancouver is a highly multicultural city with strong influences from many cultures. It is impossible to provide a comprehensive list and not leave anyone out, but Vancouver's population and culture has significant contributions from local communities with connections to China, Japan, Taiwan and Korea, India, Sri Lanka and Bangladesh, Fiji, Hawaii, the Philippines and Vietnam, Iran, Afghanistan, Lebanon, Syria, Brazil, Mexico, Italy, Germany, the Balkans, France, England and the US, among many others. Vancouver has a strong and active presence of Indigenous people and cultures, from the First Peoples of this place at the mouth of the Fraser River and the Burrard Inlet (the Musqueam *xʷməθkʷəy̓əm*, Squamish *Sḵwx̱wú7mesh*, and Tsleil-Waututh *səlílwətaʔl* nations), and from other Indigenous peoples from all over the Americas/ Turtle Island. The teachers, students and families in Vancouver schools bring all of these cultural connections and identifications to classrooms in schools and universities.

Most of the preservice secondary mathematics teachers in my classes are recent graduates from undergraduate programs with a major or minor in mathematics. However, unless they chose to take an optional course in the history of mathematics, most of these new teachers have been educated to think of mathematics as ahistorical, a-cultural and not connected to human lives, emotions and stories. In something close to the High Modernist tradition exemplified by the Bourbaki group in the mid-twentieth century (Gerofsky, 2008), mathematics has been presented to these students as an eternal, unchanging, abstract body of knowledge, as if it has always existed as it is practiced today. These new teachers approach mathematics as a set of theorems and proofs, concepts and skills, mostly framed in algebraic terms, that are treated as if they have always been exactly as they are now.

This ahistorical view of mathematical knowledge is then what these secondary mathematics teachers tend to bring to their own students and classes. Each secondary teacher works with, on average, 200 students per year, so in a typical twenty-five to thirty year teaching career, an individual teacher will affect the lives and learning of 5000–6000 students. Even if only for this reason, teacher education is significant; the assumptions and ways of thinking that new teachers develop in their teacher education programs may have important influence on the way they teach thousands of learners over the course of their careers as educators.

Of course, mathematics does not stand outside of history or of human cultures and societies, even if we might consider its insights timeless. Mathematical concepts, problem-solving procedures and strategies and notational conventions are very much of the time and place where they developed and were used. Grappling with other ways of doing and conceiving of mathematics, from other times and places, can offer new representations and equivalencies, with the potential for building deeper understandings of the mathematics we teach our students (Pape & Tchoshanov, 2001).

Even a small difference in notation can have a profound effect on the possible interpretations and uses of a particular mathematical idea. To gain insights into historical mathematical ways of thinking, it is helpful to use the original notation and methods as much as possible, rather than immediately translating everything into our familiar contemporary algebraic notation and then treating a historical problem as if it were a current one.

## The Process of Course Design

When I was given the opportunity (in 2017) to design and teach a course in the History of Mathematics for Teachers as part of our faculty's eleven month teacher education program, I was happy to take up the challenge. I had taught preservice secondary mathematics and physics teachers in this program since 2005, and could see the potential of such a course to open new teachers' views on the nature and scope of mathematics.

I was inspired by courses in the history and philosophy of mathematics and science that I had taken as an undergraduate and graduate student at the University of Toronto, and at Simon Fraser University in Vancouver. My professors in these courses (Drs. Stillman Drake, Trevor Levere and Mary (Polly) Winsor at UT, and Len Berggren, Tom O'Shea, David Wheeler and my doctoral advisor, David Pimm at SFU) modelled lively ways of teaching history, through creative arts engagement, problem-solving using the methods and notation of the historical period, and reading both primary and secondary sources (O'Shea, 2016; Berggren, 2017; Gerofsky, 2019). I drew from my memorable experiences in the courses I had taken to design the new course in math history for teachers.

Some of the issues I wanted to address in course design included the following:

My students would be teacher candidates with a background in mathematics, and not necessarily in history. How to contextualize the mathematical practices and discoveries of other eras without overloading students with historical/ political information, lists of dates to memorize, or long lectures that might not be meaningful? How much general historical information should be included alongside the history of mathematics specifically?

How should I balance readings with activities and projects? What balance is needed between learning historical facts and engaging with the mathematics of other times, places and cultures to take away something meaningful?

How could I integrate learning about the history of mathematics and thinking about the pedagogy of teaching secondary school math with history?

There were constraints on the course, not least of which was the fact that it was only one semester long (13 weeks), and this was definitely not enough time to engage meaningfully with the entire history of mathematics. So another question became: which historical periods, cultures, mathematical topics and mathematicians should be included and excluded from the course?

This latter question became amplified for me as I taught and re-designed aspects of the course over several years' teaching it. I was deeply aware of the masculinist, Eurocentric nature of many of the textbooks and resources conventionally used to teach the history of mathematics, and I wanted to avoid reproducing those biases. I was also aware of the multicultural, multigendered and multiracial nature of my students (and their future students), and I am strongly committed to more equitable and, simply, truthful representation of the history of mathematics.

Given this awareness and these commitments, it was important to me to move away from an exclusively ‘dead white European males’ view of mathematics history, and to include *both* the ‘standard’ European male mathematicians *and* mathematicians of other cultural, gendered and racial identifications. I also wanted to emphasize that the somewhat conventional ‘individual genius’ narrative of discovery in the history of math and science was seldom accurate, and that new mathematical ideas were often developed through the exchange of ideas and collaborative work. I wanted my students to see aspects of their own identifications in the intriguing cultural and historical mathematics we would be studying, and to appreciate that people who are diverse in every way we can imagine are fully capable of creating mathematical ingenuity and beauty.

In this pursuit of a more equitable and diverse representation of mathematical innovations throughout history, another question arose for me: Where can I find resources to research and engage with the history of mathematics from a perspective of cultural, racial and gender diversity?

One further question arose that is highly significant in the contemporary Canadian context is how to Indigenize and decolonize the history of mathematics in light of the reports of the Truth and Reconciliation Commission (TRC, [2015–2022](#))?

These reports, initially prepared after an intensive six-year inquiry of public hearings across Canada, reveal a centuries-long history of extreme abuse, racism, cultural genocide and intergenerational trauma to Indigenous peoples in Canada. First Nations, Métis and Inuit children were torn away from their families, communities, languages and cultural traditions and transported to far-away residential ‘schools’ where they were starved, beaten, sexually and psychologically abused. The recent revelation of thousands of unmarked graves of children on the grounds of these government- and church-run residential schools gives undeniable evidence of the criminal cruelty of the colonial system and the urgent need to begin a new relationship in a better way between settlers, Indigenous peoples and the land. All Canadians, and educators especially, have the responsibility to take up the work of decolonization to start the reconciliation process.

How to do this work effectively in a course on the history of mathematics for teachers? I continue to struggle with this as I re-think my course syllabus each year. There are aspects of Indigenous mathematics included in the course, but I feel that these are still inadequate, especially as people are still just beginning to develop resources for researching and teaching math history from an Indigenous point of view.

## **Developing the Course Syllabus**

Over the five years that I have taught the course in the History of Mathematics for Teachers, I have developed the following syllabus in response to the questions noted above, trying to balance readings with participatory activities and experiences,



Eurocentric accounts of history with more diverse and Indigenized ones, a focus on the accuracy of historical representation with a focus on pedagogy, and the use of newer and older resources in many media to help students imagine the realities of other times and cultures.

The course objectives, taken from the 2021 course outline, reflect my wish to represent the history of mathematics in an equitable way, acknowledging the contributions from every culture:

“This course is an introduction to the history of mathematics as a background to teaching secondary school mathematics in BC. It is expected that the course (a) will help to understand more about the way that mathematics developed historically, in all cultures and places; (b) bring a focus on humanity, human endeavor and emotion to your understanding of mathematics, to help make it a subject that is part of our shared human heritage; (c) develop ways of teaching mathematics that incorporate an appreciation of history and culture, to reach your students in cultural as well as abstract ways; (d) improve your abilities to communicate mathematics in many modes and forms to stimulate learners’ interests and meet their needs; (e) expand your curiosity about mathematics, teaching and learning; (f) become a lifelong learner and contributor to the community of math educators.

We will work with mathematics history from a wide range of cultures and times, including some of the following:

- Babylonian mathematics
- Ancient Egyptian mathematics
- Mayan and Incan mathematics
- Mapping from the Marshall Islands, Greenland and other cultures
- Ancient Greek mathematics
- Chinese and Japanese mathematics
- Indian mathematics including Vedic math
- Mathematics of medieval Islam
- Mathematics of Renaissance Europe
- Early modern to contemporary mathematics (largely through project work)”

### *Course Readings*

In trying to realize these objectives, I have introduced the following topics, readings and activities in this course. Selections in **bold** reflect topics that are not often included in earlier Eurocentric accounts of mathematics history – although Babylonian and Egyptian mathematics (which are not European) have ‘traditionally’ been included in mainstream courses and tellings of mathematics history.

- Tzanakis, Arcavi et al. (2002): A survey of reasons for teaching (or not teaching) the history of mathematics in math classes.
- **Joseph (1999): Introductory chapter: The history of mathematics: Alternative perspectives (pp. 1–22)**

- Joseph (1999): section on Babylonian proto-algebra.
- Gerofsky (2004): Section on the history of Babylonian word problems.
- **Gustafson (2012): A comparison of Classical Chinese and ancient Greek mathematics, and a revisiting of the evidence that the ‘Pythagorean Theorem’ was well known in China long before Pythagoras was born.**
- **Joseph (1999) on classical Chinese mathematics: counting rods, magic squares, systems of simultaneous equations.**
- **Doolittle (2007): an essay on mathematics and Indigenous cultures by Haudenosaunee mathematics professor, Edward Doolittle.**
- **Iseke-Barnes (2000): essay by Indigenous math educator Iseke-Barnes on decolonizing mathematics education in the North American context.**
- **Major (2017): essay on our perception of numbers, with a focus on classical Maya numeration systems.**
- Reading St. Vincent Millay’s poem on Euclid and a parody of it, and commenting on Euclid’s influence.
- Looking at Euclidean proofs from Byrne (1847/2022) and Heath (1956) editions and comparing the graphic and verbal approaches from an educator’s point of view.
- Excerpts from Scott (2006): Plato’s *Meno*.
- **Excerpts from Berggren (2017) on the mathematics of medieval Islam: dustboard arithmetic and achievements of Islamic Golden Age mathematicians.**
- **Reading Rumi’s mathematically-reference poem, The Lover’s Tailor Shop and excerpts from mathematician/ poet Umar Al-Khayyami’s poetry**
- Schrader (1967) on the trivium and quadrivium, and the mathematics taught in medieval European universities.
- Hadley & Singmaster (1992) on Alcuin’s medieval word problems.

### *Video Screenings*

Some videos available online have been used where appropriate to supplement course readings:

- BBC (1993): Documentary film about Andrew Wiles’ work on the proof of Fermat’s Last Theorem.
- A variety of short videos showing visual proofs of the Gou-Gu/ Pythagorean Theorem.
- **Short videos of kids using imagined abaci to do rapid calculations.**
- **BBC (2013): Marcus de Sautoy documentary on Indian classical mathematics and mathematicians <<https://www.youtube.com/watch?v=pElvQdcaGXE>> and <[https://www.youtube.com/watch?v=DeJbR\\_FdvFM](https://www.youtube.com/watch?v=DeJbR_FdvFM)>**

- Sarah Chase: Dancing combinatorics, phases and tides <<https://vimeo.com/251883173>>

### *Mini Lectures*

This is a seminar course that emphasizes active learning and participation, rather than a lecture-based course. However it is still important to communicate contextual background knowledge to set the scene for the mathematical activities we undertake in class. For this reason, short lectures ('mini-lectures'), about 15–20 minutes long, are included at some points in the course.

- Introduction to Mesopotamia and Babylonian mathematics in historical/ geographical context
- Introduction to ancient Egyptian mathematics in historical/ geographical context
- Introduction to ancient Egyptian multiplication by doubling and halving. Discussion about how this might be useful in teaching multiplication.
- Introduction to ancient Egyptian fractions from Ahmes' Papyrus
- Introduction to the ancient Egyptian proto-algebraic method of false position. Discussion about how this might be useful in teaching initial algebra.
- Introduction to word problems in the context of the history of mathematics. Discussion about the nature and uses of word problems in math education.
- **Guest talk by musical/ mathematical historian Sara de Rose on connections between astronomy, music and mathematical ratios in ancient Babylonian, Greek and Chinese contexts.**
- **Introduction to the mathematics of classical India and the legacy of Brahmagupta.**
- Introduction to the importance of Euclid in the history of mathematics.
- Exploration of further topics in ancient Greek mathematics: Zeno's paradoxes; Diophantine equations; Archimedes' accomplishments; ancient Greek number systems; three impossible problems in Greek compass-and-straightedge geometry.
- **Guest talk by Belizean UBC doctoral graduate Dr. Myron Medina on Classical Maya mathematics and his doctoral dissertation research in Maya traditional mathematics.**
- Introduction to medieval European mathematics in historical context.
- Looking at the famous illustration of Hindu-Arabic numerals and algorithms vs. medieval European counters/ abaci. Introduction to Fibonacci (Leonardo of Pisa) and readings from his *Liber Abaci*.
- Introduction to MoMATH (the Museum of Mathematics in New York) and Wolfram's Historical Mathematical Artifacts online resource at <<https://history-of-mathematics.org/>>
- **Introduction to Inca qipus and their social and mathematical significance.**

- **Introduction to Marshall Islanders' and other Pacifika navigators' highly accurate mappings of ocean swells and islands and navigation by the stars.**
- **Introduction to Greenland Inuit edge-carved maps.**

## *Activities*

Throughout the course, students engage in hands-on mathematical work that replicates historical ways of doing mathematics, with the aim of developing an appreciation for the intelligence, ingenuity and originality of the mathematics of other times, places and cultures. These activities promote an 'insider' view of diverse historical mathematical techniques and ways of representing and thinking about mathematical patterns, and I have seen that engagement with these mathematical activities has changed students' understanding and appreciation for cultures and eras different from their own.

I offer a bulleted list (below) of all the activities that are part of the course, followed by a detailed explanation of two of them:

## *List of Activities that Replicate Historical Ways of Doing Mathematics*

- Deciphering and interpreting a Babylonian clay tablet (nine times table)
- Making sense of a Babylonian clay tablet (pairs of base 60 numbers including fractions that multiply to 60)
- Constructing own table of base 60 number pairs that multiply to 45
- Working on a (translated) Babylonian word or story problem
- Brainstorming, researching and writing about 'why base 60?' in Babylonian mathematics.
- Introduction to ancient Egyptian numeration
- Trying out the ancient Egyptian multiplication and division algorithms
- Trying out problems using ancient Egyptian unit fractions
- Interpreting a mathematical wall painting from the tomb of Mena, Egypt, 1549 BCE (showing rope stretchers, mathematical scribes at work, calculations of the areas of fields and volumes of grain, etc.)
- Researching and interpreting the Eye of Horus drawing as a representation of Egyptian fractions.
- Problem solving using the ancient Egyptian method of false position, using the University of Surrey page on Egyptian fractions by Ron Knott <<https://r-knott.surrey.ac.uk/Fractions/egyptian.html>> and the N-Rich Maths resource <<https://nrich.maths.org/1173>>

- **Exploring aspects of classical Chinese mathematics using the online resource at <<http://paulscottinfo.ipage.com/history/mark/mhh.html>>**
- **Solving Sun Tzu's 'Dishes' puzzle without using algebra**
- **Constructing magic squares**
- **Hands-on classical Chinese geometric proof with paper and scissors of the Gou-Gu (Pythagorean) theorem, and other visual/ geometric proofs of this theorem.**
- Learning to use abaci to do arithmetic.
- Hands-on exploration of a Pythagorean monochord and relationships of fractions to musical tones and harmonics.
- Hands-on exploration of Euclidean number theory proofs: relatively prime numbers measured with string
- Experimenting with dancing the first three proofs in Euclid's Elements Book 1.
- Reading excerpts from Plato's *Meno* aloud as reader's theatre and discussing Platonic views of the sources of mathematical knowledge.
- **Experimenting with the techniques of Vedic mathematics.**
- **Trying out the student activities from Ancient Indian rope geometry <<https://www.maa.org/press/periodicals/convergence/ancient-indian-rope-geometry-in-the-classroom-student-activities>>**
- **Solving problems with the techniques of dustboard arithmetic from medieval Islamic mathematics.**
- Solving Alcuin's medieval European 'Problems to sharpen the young' and discussing the oddities of these word problems and their sources.
- **Making replicas of qipus to create mathematical and record-keeping notation.**
- **Experimenting with stick maps to represent land contours outdoors. Experimenting with creating carved edge maps to represent shorelines, pathways and elevations.**

#### **An Example of Two Course Activities in Greater Detail:**

*Making sense of a Babylonian clay tablet (pairs of base 60 numbers including fractions that multiply to 60) and constructing own table of base 60 number pairs that multiply to 45*

It is interesting and challenging to do arithmetic in bases that are different from our familiar base 10 system. The Babylonian standard, base 60, is at once familiar and unfamiliar in our culture, because we continue to use it for telling time and (in a limited way, for working with angle measures in degrees as well). Our cultural familiarity with the 60 second minute and 60 minute hour can make for some surprises when working with Babylonian fractions. For example, the base 60 fraction for one half is: 30, one quarter is: 15, and three quarters is: 45 – all familiar from our understanding of the quarter hours and half hours when working with clocks. Less familiar base 60 fractions are one third (:20), one sixth (:10), one tenth (:06) and one twelfth (:05), but thinking about the sixty-minute hour helps clarify these Babylonian fractions as well.

Col. I	Col. II	Col. I	Col. II	Col. I	Col. II
2	30	16	3,45	45	1,20
3	20	18	3,20	48	1,15
4	15	20	3	50	1,12
5	12	24	2,30	54	1, 6 ,40
6	10	25	2,24	1	1
8	7,30	27	2,13,20	1,4	56,15
9	6,40	30	2	1,12	50
10	6	32	1,52,30	1,15	48
12	5	36	1,40	1,20	45
15	4	40	1,30	1,21	44,26,40

Fig. 10.1 From Babylonian clay tablets

Once students are able to recognize the correspondences between base 10 and base 60 fractions, it is possible (though still challenging) to understand how to do arithmetic with these fractions. The examples we work with begin by examining and making sense of an existing Babylonian clay tablet that shows pairs of numbers that multiply to 60 (see Fig. 10.1 below, taken from Aaboe, 1963, p. 10, along with my instructions to the class for the exploratory activity).

*What might these tables mean?*

*Note that, in this notation, commas separate place values (for both whole numbers and fractions).*

*Can you figure out the common theme here?*

*Why are certain numbers missing from the left hand column? For example, there is no 7, 11, 13, etc.*

*How do fractions in the Babylonia style connect with our fractions? (Keep this in mind as we learn about ancient Egyptian fractions later on...)*

*Could you create a table of this kind with a different number as its focus — for example, 45?*

It is easy to see that the whole number pairs multiply to 60 (for example, 2 and 30, 15 and 4 or 20 and 3), but more challenging to see the same pattern when working with base 60 fractional notation (for example, 9 and 6, 40 or 25 and 2,24). It is even more challenging when the base 60 fractions go into more than one place to the right of the units column – for example, 54 and 1,6,40 or 27 and 2,13, 20 – or if there are numbers with base 60 fractions in both columns – for example, 1,4 and 56,15 or 1,21 and 44,26,40. The range of difficulty in this table offers a good ‘low floor, high ceiling’ challenge for students, and it’s interesting to see that this translation to Hindu-Arabic numerals of an actual Babylonian clay tablet was designed by its unknown maker to offer this kind of range. It may have been a teaching tablet or at least a calculating table for students at a scribal school, and this is interesting to consider from a pedagogical point of view too. Even four millenia ago, good

mathematics teachers seem to have found entrance points and then ways to ramp up the difficulty level for their students!

One cannot help but be impressed by the virtuosity and mathematical understanding of Babylonian mathematicians and scribes, who could make sense of decomposing 60 into  $(1 + 21/60) \times (44 + 26/60 + 40/3600)$ . It takes a good deal of work and thought for us to make sense of the second column of fractions in this notation, partly because a denominator of  $60^2$  is so large and unfamiliar. It is especially impressive to note that Babylonian mathematicians did this work on wet clay with only a triangular-ended stylus – a very different technique from either pencil-and-paper algorithms or electronic calculators! It is this kind of appreciation for the ingenuity of past civilizations and their mathematics that this class aims to stimulate.

Once the given tablet starts to make sense, it is highly engaging to construct one's own multiplication table of Babylonian 'reciprocals' multiplying to 45 rather than 60, especially with the added challenge of including some more difficult fractional amounts, on one or both sides of the multiplication. Here are some examples of student's tables for 45, resulting from group work and discussion. It's interesting to see all the groups taking a systematic approach, and working with the conundrum of trying to create rational numbers in base 60 corresponding to primes like 7, 11 and 13. Students also started to notice reciprocating patterns in the numbers in both the 60 and 45 tables, and to begin to look for similar patterns in a reflexive way as they returned to our familiar base 10 system (Fig. 10.2).

### ***Major Course Assignments***

There are three major course assignments, listed briefly below: (1) In pairs: doing ancient puzzles in ancient and modern ways. Each pair picked a different puzzle from a selection from Scriba & Schreiber (2010) and Aaboe (1963). Solutions presented to class and handed in to instructor.

(2) Individually: exploring the history of a mathematical topic in the British Columbia secondary mathematics curriculum and how the history might enhance the teaching of the topic. Each student adds slides to a shared slide deck available to the whole class as a teaching resource and presents to class.

(3) In pairs: exploration of a topic that interests you that was not covered in the course. The research should culminate in building or making a work of art, mathematical device, performance or object that connects the history of mathematics with practical or beautiful results. Presentation to class, and work donated to class mathematical art gallery. Students also wrote short weekly blog posts reflecting on aspects of their readings, activities or class discussion topics.

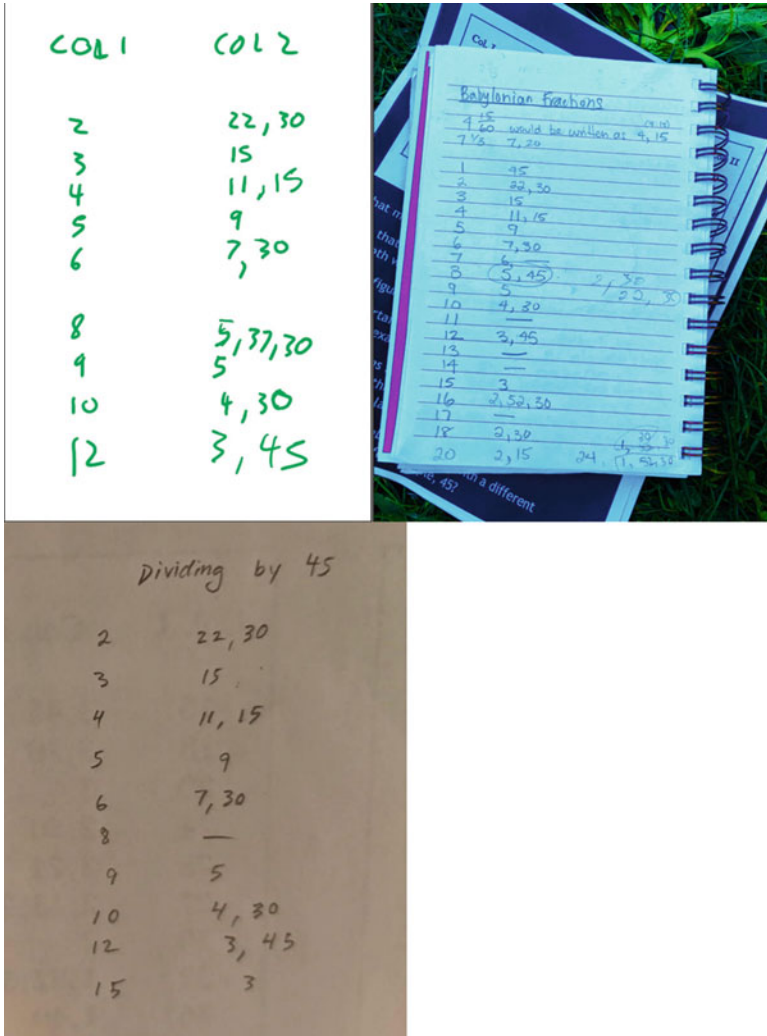


Fig. 10.2 Students' work

### Did these Ideas Make a Difference for Future Teachers?

It is important to assess how the teacher candidates in the course have actually taken up the ideas, experiences, readings and discussion topics they are encountered in the course. Do the main course objectives make an impression on students? Do they expand their view of the nature and sources of mathematics? Are they more able to appreciate mathematics as part of our shared human heritage, and as a cultural treasure arising from every world culture? How will they share what they have learned with their future secondary school math students?



The written data I have available to assess student responses comes from two sources: anonymous student course evaluations (which I can quote), and student blog writing from the course over several years (which I can paraphrase, but not quote, without specific written permission). Out of about twelve blog posts from the course, several typically included comments relevant to a discussion of the course objectives:

1. Reflections on reading Joseph's (1999) introduction to *The crest of the peacock*.
2. Reflections on reading Gustafson (2012)'s article, Was Pythagoras Chinese?
3. Reflections on reading Berggren (2017) on medieval Islamic mathematics
4. Reflection and assessment of learning at the end of the course

The weekly blog posts were short (1–3 paragraphs), low-stakes pieces of writing that I commented on, and marked for completeness and relevance to the topic. Almost everyone in class each year completed the blog posts in a satisfactory way and received full marks for this aspect of the course (15% of the final grade). Blog posts responded to prompts I offered for reading responses or for working on a puzzle or problem, and the students' weekly writing often guided class discussions. Students generally seemed quite frank about their ideas as expressed in their blog posts, and they knew that there was not penalty for having a dissenting opinion or different ways of viewing things.

Below are some of the student comments, quoted or paraphrased, in relation to the stated course objectives. Pseudonyms are used in place of actual student names.

### ***Student Comments: General Remarks***

Over the five years I have taught this course so far, from 2017 to 2021, there has always been an intention to emphasize the ways that mathematics and mathematical ways of thinking are part of our human heritage, across all times, places and cultures, and to help my students experience the beauty and ingenuity of mathematics developed in other eras and cultures. Student writing in the course has picked up on these intentions every year in students' writings about the course.

However, it is evident to me that there is far greater student uptake this year (2021/22) of the course theme of decolonization of a white, male, Eurocentric portrayal of the history of mathematics. More of the students have commented on issues of racism, sexism, white supremacy and the attempted erasure of the cultural accomplishments of colonized and subjugated peoples. Furthermore, the students in this year's class often mentioned readings and discussions from their other university classes on topics of social justice, decolonizing and Indigenizing teaching and learning, the Black Lives Matter (BLM) movement, and the process of Truth and Reconciliation (TRC) in Canada. In the context of these large-scale national and international societal movements for justice, teacher candidates have a heightened awareness of the harm done in the name of colonization – and they now have the vocabulary and background to be able to discuss this in well-reasoned and

thoughtful ways. The History of Math for Teachers course has adjusted and changed somewhat over these five years, but the society around it has changed more. In the wake of the COVID 19 pandemic, and in light of the TRC, BLM, Me Too Movement and other recent activist and awareness movements, students' perceptions of this math history course have focused more intensely on these threads running through the course design.

The students in this course (and in my university's teacher education program) have always been diverse in many dimensions including so-called 'race', national origins, ethnicities, languages and religions, gender identities, age, abilities and more. In the past year or two, I have seen an increased distinction between the writing of students who affiliate with equity-seeking groups and students who identify more with mainstream groups. Many of those who are included in the mainstream comment only on aspects of the course that are not necessarily related to decolonization (and since the course is 'about' many different facets of mathematics history and pedagogy, that is a perfectly alright). In contrast though, almost all of the students with identifications beyond the mainstream *do* highlight the theme of decolonization in the course, along with their discussions of other aspects of the curriculum.

### *Other General Comments*

#### **Student Comments on Objective 1: Understanding More About the Way that Mathematics Developed Historically, in All Cultures and Places**

This was the objective that received the most student commentary by far. Some students spoke specifically from their own positionality and experiences, others from a more generally philosophical view.

An example of the latter came from L, an Indigenous teacher candidate, who identified the course content with the spirit of decolonization. L considered European concepts of 'the march of time', progress, competition and haste as colonial perspectives, and expressed the hope that acknowledgement of the non-European sources of mathematics might help expand students' thinking beyond these patterns. L also was surprised at how Eurocentric his own education had been, and mentioned that, up to the completion of an undergraduate degree, he had only heard about ancient Greek sources of mathematics.

S, a student of Chinese heritage, said that he entered the course with little background in the history of mathematics, and questioned whether integrating mathematics history was necessary or even helpful for learners. He was surprised to find that he enjoyed the course, and admitted that he had been unaware of the diverse cultural contributions to mathematics before beginning this class. He spoke of the ravages of colonialism in the suppression of diverse cultural knowledges. He saw this course as a way to begin to connect general ideas about decolonizing pedagogy with specific ways to do this in secondary mathematics classes. S also

noted that it was shocking and disheartening that there remained some cultures still excluded from the history of mathematics, especially Indigenous cultures of the Americas and cultures from southern Africa, in part because little had been published on their contributions.

M, a student of European origin, noted in a similar way that some cultures' contributions were excluded from the history of mathematics because there was not a high level of documentation that had survived over the centuries, sometimes for devastating reasons, referring to the burning of whole libraries of Maya bark scroll codices by Spanish Catholic missionaries and colonial administrators in Central America. She remarked as well that it was amazing to put oneself into the thought patterns of ancient civilizations by working with their mathematical systems and approaches directly.

Several other students remarked on the ways the course changed their perspectives on mathematics as a whole, helping them see that mathematics was not just a white, male European field of endeavour. They were happy to see a contradiction of this false impression of white superiority, and to see people of other genders, races and cultures acknowledged as important contributors to mathematics as thinkers, philosophers and creative scientists.

Some students spoke explicitly from their own positionality and national and ethnic background. One student, Y, who was educated in the UK, said she was astounded and overwhelmed by the diversity of cultural sources of mathematics beyond the ancient Greeks, after having been schooled to think that the Greeks were the sole originators of mathematical ideas. She also expressed shock that so much of mathematics history could have been overlooked or suppressed, when even the ancient Greek mathematicians acknowledged their debt to other civilizations including the Babylonians and Egyptians.

Other students, D, A and V were educated both in China and Canada, and had learned about Chinese mathematical contributions to mathematics history in a detailed way before being exposed to the European contributions to mathematics history. With that background, they were not surprised at the contributions of Chinese mathematicians, but they were shocked to see how distorted a view of history was being presented as the norm in some conventional Western histories of mathematics.

D wrote in particular about the rise of societal movements like BLM and Stop Asian Hate, and about the increasing importance of awareness of political and racial issues for him as a young adult and a new teacher. He made a case for the significance of our origin stories in shaping our sense the world and whether we could feel pride in our own identities and cultures – an important consideration for teachers in a strongly multicultural society.

A wrote that it would certainly make a difference for her students' learning to acknowledge the diverse roots of mathematics, and that it might possibly make a very big difference. A discussed the diversity of Canadian society, and the importance for students of seeing and discussing the diversity of the mathematicians who created wonderful theorems and concepts.

V discusses the idea that ‘history is written by the winners’, and notes that our present Canadian education system had its origins in 18th and 19th century England, at the height of the Industrial Revolution and the British Empire, so that it should be unsurprising that foundational textbooks emphasized Eurocentric perspectives. Interestingly, he speculates on what it might have been like if modern textbooks had their origins one or two millennia ago. Would they have spoken more about the mathematical contributions of the Islamic world, India and China?

Finally, R talked about his previous impression of math history as simply memorizing where and when a famous European mathematician was born – and then getting on with doing the usual practice worksheets and exercises. He appreciated an approach to the history of mathematics that went beyond naming prominent historical figures and instead took a deep dive into layers of meaning through examining who was included and excluded, how representation and accuracy or inaccuracy played out in our view of the past. He appreciated the in-depth experience of trying out the mathematical techniques of earlier times. He felt that this layered approach gave purpose to the readings and assignments students completed throughout the course.

### **Student Comments on Objective 2: A Focus on Mathematics as Our Shared Human Heritage**

Many of the students expressed a sense of joy in discovering the shared human heritage of mathematical discovery across cultures, sometimes with special reference to their own cultures, but often more generally in developing insights into the beauty of different ways of thinking and working with mathematical relationships and ideas.

W, a student who grew up in the Middle East and India, wrote about the joy of the continuity of math across the ages and around the globe. She saw mathematics as a powerful connection among people as we all participate in an ongoing journey with mathematical ideas. W used a metaphor of mathematics as a thread weaving a tapestry across time and space, and noted the hypocrisy of only acknowledging Eurocentric perspectives when the global history of mathematics could be such a unifying force. She expressed awe, amazement and fascination at learning about the mathematics of India and of Mayan cultures, and spoke of the wondrous brilliance of mathematicians from these places and eras, and a bittersweet emotion at the realization that some of these civilizations were now solely in the past.

Several students, including L and Y (cited in the previous section) as well as O, wrote about their surprise and gratitude in learning that the pursuit of mathematical knowledge is shared by most or all human cultures throughout history. They described this realization as eye-opening and surprising. These students acknowledged many different and equally valuable purposes for the development of mathematical knowledge, from the very practical to the more abstract. They also expressed amazement at the high degree of mathematical communication and collaboration amongst peoples across huge geographical and linguistic/cultural

divides, even in ancient times – something we might not expect in eras when travel and communications were slower and more difficult than today.

Finally, students J, M, N and Z wrote about their appreciation of the humanity behind the mathematics that emerges in taking a holistic approach as we did in this course. M talked about being shocked at the fact that Babylonian mathematics used base 60, and at seeing how she could learn to work in the very different context of the base 60 system when she was so accustomed to our familiar base 10. N was delighted to see *people* brought back into a mathematics course and to see that decolonizing mathematics education could also be an awe-inspiring process. Z remarked that mathematics was not just the work of a single man or of a few lone geniuses, but rather a treasure trove for all human beings, with many possible approaches adding to its richness.

### **Student Comments on Objective 3: Incorporating an Appreciation of History and Culture in Their Future Teaching**

As new teachers embarking on careers in secondary mathematics education, many of the students commented on ways that they plan to incorporate mathematics history in their own teaching.

C expressed a strong interest in trying out some of the ancient, non-algebraic methods of mathematical problem-solving with her students, and talked as well about teaching mathematics through dance and art (connecting with Objective 4 as well). She wrote about her new insights into the variety of ways we can teach mathematics, and that worksheets and exams were no longer the only means she could see for teaching math.

K also liked the assignment where students solved ancient problems in ancient and modern ways, and wanted to try this with her own classes. She wrote that this approach could help learners deepen their understanding of basic mathematical concepts, and see that there is more than one true or valid way of doing math. She saw the value of taking a more universal, not-exclusively-Eurocentric view of mathematics history as a way of welcoming students who were newcomers to Canada and letting them know that their cultures are valued. K spoke about her pride as a person of Asian heritage in learning about Asian mathematical contributions, and expressed a wish to help all her students feel this kind of pride in their cultural inheritance.

J was intrigued to see that many of the Islamic mathematicians we studied worked in multidisciplinary ways, and were also poets, astronomers, geographers and artists. Through teaching her own students about these multifaceted and interesting historical mathematicians, she saw ways of making math less ‘stuffy’ and more human. She felt that this would give encouragement to kids who had a range of interests, and might not see themselves in the stereotype of mathematicians as people ‘obsessed with numbers’.

S, B, N and F wanted to let their own students know that Eurocentric accounts of mathematics history did not tell the whole or true story by any means. They wrote

about their interest in teaching about the diversity of mathematical cultures as a way of acknowledging the plethora of mathematical contributions that originated in many places and times.

Students E and D were impressed that there could be plenty of creativity and interdisciplinary integration ‘even’ in a math class. D was surprised that math history didn’t need to be dry, stuffy or forced; E was interested in trying out different, varied historical methods as modes of inquiry for learners to explore mathematics experientially through opening their minds to patterns and connections. Both were interested in using ideas and techniques from other historical periods as a way to show that mathematics was more human and interesting than the ‘black and white approach’ or ‘wrong and right answer’ binary that they had commonly seen in math classes.

T found the course one of his most interesting, and could see that learning about earlier civilizations and their mathematical knowledge could strengthen his students’ understanding of the ways that ideas could give rise to conjectures, theorems and proofs. He wrote that his experiences in the class changed the way he thought about presenting mathematical problems, to get the big picture of the history of the mathematics we use in contemporary times. He suggested that we include more on Indigenous mathematics and its integration with other aspects of culture.

#### **Student Comments on Objective 4: Communicating Mathematics in Diverse Modes to Stimulate Interest**

This course integrated the visual and performing arts and ‘maker culture’ into the study of mathematics history (for example, using ideas from one of our course books, Shell-Gellasch (2008)). Some of the students were inspired by these learning activities to design similar arts-based engagements for their own students.

W used the metaphor of a journey for the trajectory of each of our classes in the course, and found a lot of fun in the activities and readings, which she found to be at once simple and transformative. She found that the hands-on activities and problem solving deepened her curiosity about math. W was especially intrigued by the integration of architecture and mathematics in Islamic cultures, and found that the arts-based approach challenged her preconceptions about who did math and why, and which mathematics had societal relevance. She plans to bring these kinds of activities and projects to her own classes.

C commented that she learned that mathematics is also art and beauty, and that mathematical arts can take multiple forms, from dance to tilings. C and Y worked together on creating a portable working sundial as a final project for the course, and Y commented that she learned so much from this project that she felt confident in teaching it to her own students. Both expressed their intention to create arts-based math history assignments in their own secondary school math classes.

## Why Does This Matter?

The preservice secondary math teacher students in my class clearly enjoyed many aspects of this approach to the history of mathematics for teachers, and found benefits and even inspiration in a variety of readings, activities and assignments. But there may still be questions about whether this sort of course is truly important for new math teachers, or whether it is something optional or peripheral. Why does this kind of course matter?

Writing from student K offered me the most moving description of the deep reasons for teaching math history in this way, to student teachers and eventually their own students. K grew up in India and Canada, and wrote about students' sense of self confidence, cultural pride and ambition to achieve good things that arise from identifying with mathematicians that represent your cultural background.

K writes that it is absolutely clear what a difference it makes to learn about someone from your own culture doing excellent, groundbreaking work and achieving great things. He speaks of a sense of pride that helps shape a student's identity and aspirations.

With heart-breaking candour, K writes that he can't name a single person from his own cultural background who accomplished anything amazing in their life. That is a terribly sad statement coming from a young person embarking on a teaching career in our Canadian society that is still far from being egalitarian and non-racist. K writes that he is sure there are plenty of accomplished people from his culture, but he has never been taught about any of them. He writes that, when you are only presented with images of the supremacy of white people in school books, it can make you feel that as a non-white person, you are not destined to accomplish much.

It takes some time for the gravity of this simple statement to sink in. The feelings that K has experienced in a racialized society, where his family and community are not portrayed as accomplished or successful, has had a profound effect on his sense of self and his own possibilities. K is able to see this story in the context of his own teaching and to reflect on it with an honesty and even humour that defuses the emotional effects to some extent, but what he is expressing here may be absolutely devastating to many young people's sense of hope for the future, optimism about their own abilities and feelings of self-efficacy. As K's classmate N writes, the lack of representation of many non-European peoples and cultures in our curricula takes away from student confidence and may limit their imagination and engagement with learning in mathematics and other areas. Is this not enough reason to teach a more inclusive course in the history of mathematics in teacher education?

## Coda: Areas for Future Development

As I write the conclusion to this chapter, I am aware of the many lacunae in my own knowledge and resources around intercultural histories of mathematics. There are cultural and historic approaches I would very much like to include in the course, but I

am not sure how to research them, as they are not yet widely published in the literature.

Within the Canadian context, it is of prime importance to include the Indigenous cultures of Turtle Island/ the Americas and their mathematical ways of thinking and doing, but how to learn about these contributions if there are not many published studies?

Not all cultures create the written documentation that counts as ‘historical’ within historiography; for example, cultures of predominantly oral, storytelling societies may have non-written ways of keeping history alive.

Not all cultures have created a category analogous to the English-language discipline we call ‘mathematics’ – but that does not mean that people in that culture do not engage in what people might identify as reasoning, awareness of patterns and patterns-of-patterns, design, play and other aspects of life that can be viewed as mathematical.

I ask my colleagues for advice in how to move forward in decolonizing this course in the history of mathematics for teachers, by including meaningful explorations of Indigenous and other cultural ways of ‘being mathematical’, with the aim of welcoming new teachers and their future students into active engagement with mathematical fascination and beauty.

## References

- Aaboe, A. (1963). *Episodes from the early history of mathematics*. Mathematical Association of America. ISBN: 0-88385-613-1.
- BBC. (1993). *Fermat's Last Theorem - The theorem and its proof*. Film retrieved May 2022 from <<https://www.youtube.com/watch?v=6ymTZEeTjI8>>
- Berggren, J. L. (2017). *Episodes in the mathematics of medieval Islam*. Springer. ISBN 978-1493937783.
- Byrne, O. (1847/2022). *The first six books of the elements of Euclid: In which coloured diagrams and symbols are used instead of letters for the greater ease of learners*. Taschen. ISBN: 978-3836577380.
- Doolittle, E. (2007). Mathematics as medicine. In Liljedahl, P. (Ed.) *Proceedings of the 2006 Annual Meeting of the Canadian mathematics education study group* (30th, Calgary, Alberta, Canada, Jun 3-7, 2006). Canadian Mathematics Education Study Group. Retrieved May 2022 from < <https://eric.ed.gov/?id=ED529562>>
- Gerofsky, S. (2004). A man left Albuquerque heading east: Word problems as genre in mathematics education. Peter Lang. ISBN: 978-0820458236.
- Gerofsky, S. (2008). Mathematics education. In S. Mathison & W. Ross (Eds.), *Battleground schools*. : Greenwood, vol. 2, pp. 391–400. ISBN: 978-0313339424.
- Gerofsky, S. (2019). Approaching the history of mathematics via the performing arts: Kepler: A “renaissance folk play” in verse. *The Mathematical Intelligencer*, 41, 57–66.
- Gustafson, R. (2012). Was Pythagoras Chinese? Revisiting an old debate. *The Mathematics Enthusiast*, 9(1), Article 10. Retrieved May 2022 from <<http://scholarworks.umt.edu/tme/vol9/iss1/10>>
- Hadley, J., & Singmaster, D. (1992). Problems to sharpen the young. *The Mathematical Gazette*, 76(475), 102–126.
- Heath, T. L. (Ed.). (1956). *The thirteen books of Euclid's elements*. Dover. ISBN 978-0486600888.



- Iseke-Barnes, J. M. (2000). Ethnomathematics and language in decolonizing mathematics. *Race, Gender & Class*, 7(3), 133–149.
- Joseph, G. G. (1999). *The crest of the peacock: Non-European roots of mathematics*. Princeton University Press.
- Major, A. (2017). Numbers with personality. In D. Swart, C. Séquin, & K. Fenyvesi (Eds.), *Proceedings of bridges 2017: Mathematics, art, music, architecture, education, culture*. Retrieved May 2022 from <<https://archive.bridgesmathart.org/2017/bridges2017-1.html>>
- O’Shea, T. (2016). *Mathematics education across time and place: Over two millennia from Athens to Zimbabwe*. FriesenPress. ISBN 978-1460286081.
- Pape, S. J., & Tchoshanov, M. A. (2001). The role of representation(s) in developing mathematical understanding. *Theory Into Practice*, 40(2), 118–127.
- Schrader, D. V. (1967). The arithmetic of the medieval universities. *The Mathematics Teacher*, 60(3), 264–278.
- Scott, D. (2006). *Plato’s Meno*. Cambridge University Press.
- Scriba, C. J., & Schreiber, P. (2010). *5000 years of geometry: Mathematics in history and culture*. Springer. ISBN: 978-3-0348-0898-9.
- Shell-Gellasch, A. (Ed.). (2008). *Hands-on history: A resource for teaching mathematics*. Mathematical Association of America.
- TRC (Truth and Reconciliation Commission). (2015–2022). *Reports of the Canadian Truth and Reconciliation Commission*. Retrieved May 2022 from <<https://nctr.ca/records/reports/>>
- Tzanakis, C., Arcavi, A., Sa, C. C. D., Isoda, M., Lit, C. K., Niss, M., de Carvalho, J. P., Rodriguez, M., & Siu, M. K. (2002). Integrating history of mathematics in the classroom: An analytic survey. In *History in mathematics education* (pp. 201–240). Springer.

# Chapter 11

## The Role of History in Enriching Mathematics Teachers' Training for Primary Education (6–12 Years Old Students)



Yuly Vanegas, Joaquín Giménez, and Montserrat Prat

**Abstract** The benefits of incorporating history into mathematics teacher education have received considerable attention and have been discussed for decades. Nevertheless, the knowledge of epistemic principles for Primary Educators is limited. Curriculum planning involves far more than choosing the content to be taught. Teachers must decide the instructional sequence and the methods to teach the content. Therefore, future teachers should know some roots of the epistemic formation of mathematics to have justifications for the relevance of main aspects of mathematics knowledge. Currently, the history of mathematics is introduced in secondary schools. Still, it has been excluded in many curricular explanations in the lowest levels of education, probably because some people think children do not need to be aware of developments in this discipline. In this chapter, we assume that future teachers must know about it to interpret accurately what is written in the curriculum.

**Keywords** History of mathematics · Teacher education · Primary mathematics education · Teacher knowledge

---

Y. Vanegas (✉)

Didactics of Mathematics, University of Lleida, Lleida, Spain

e-mail: [yuly.vanegas@udl.cat](mailto:yuly.vanegas@udl.cat)

J. Giménez

Department of Didactics of Experimental Science and Mathematics, Faculty of Education, University of Barcelona, Barcelona, Spain

e-mail: [quimgimenez@ub.edu](mailto:quimgimenez@ub.edu)

M. Prat

Faculty of Psicology, Science Education and Sport, Blanquerna-University Ramon Llull, Barcelona, Spain

e-mail: [montserratpm3@blanquerna.url.edu](mailto:montserratpm3@blanquerna.url.edu)

© The Author(s), under exclusive license to Springer Nature Switzerland AG 2023

S. Romero Sanchez et al. (eds.), *The Role of the History of Mathematics*

*in the Teaching/Learning Process*, Advances in Mathematics Education,

[https://doi.org/10.1007/978-3-031-29900-1\\_11](https://doi.org/10.1007/978-3-031-29900-1_11)

The benefits of incorporating history into mathematics teacher education have received considerable attention and have been discussed for decades. Nevertheless, the knowledge of epistemic principles for Primary Educators is limited. Curriculum planning involves far more than choosing the content to be taught. Teachers must decide the instructional sequence and the methods to teach the content. Therefore, future teachers should know some roots of the epistemic formation of mathematics to have justifications for the relevance of main aspects of mathematics knowledge. Currently, the history of mathematics is introduced in secondary schools. Still, it has been excluded in many curricular explanations in the lowest levels of education, probably because some people think children do not need to be aware of developments in this discipline. In this chapter, we assume that future teachers must know about it to interpret accurately what is written in the curriculum.

We begin this chapter by interpreting what one might mean by teacher knowledge relating to the use of the history of mathematics in the classroom and students' understanding. We will refer and exemplify the different preparation needs of both Kindergarten and Primary Teachers. It is known that the main reason for introducing the history of mathematics into mathematical classrooms is based upon three big and old arguments: (1) that the history of mathematics humanizes mathematics, (2) that it makes mathematics more interesting, more understandable, and more approachable, (3) that it gives insight into concepts, problems, and problem-solving (Fried, 2001). In this chapter, some of these approaches are considered. In fact, by posing historical problems and analyzing the approaches by mathematicians of previous eras, students can better understand mathematical thinking and appreciate the dynamic nature of students' mathematical learning. The history of mathematics consistently highlights that the initial driving forces of mathematical knowledge are plausible conjectures and heuristic thinking; logical arguments and deductive reasoning come into play later on.

After an initial reflection, in a second large part, we move to examine the possible implications of such teacher knowledge on instruction. We discuss the main interest in history from different perspectives: (a) History can help increase motivation and develop a positive attitude toward learning; (b) Past obstacles in the development of mathematics can help explain what today's students find difficult; (c) Historical problems can help develop students' mathematical thinking; (d) History reveals the humanistic facets of mathematical knowledge; (e) History gives teachers a guide for teaching; (f) there is a need to observe the differences between empirical and metaphorical observations to understand representational problems.

The third part of this chapter examines the assumption that teacher knowledge does not increase more because of a lack of epistemic content and historical background. In this chapter, we assume that the understanding of students' mathematical learning relating the proto-historical perspective is essential for good teaching in light of different theoretical perspectives.

## History of Mathematics and Elementary Teacher Knowledge

The use of history enables students to illustrate mathematical concepts and proofs on an empirical basis (Bartolini Bussi, 2000).

We are aware that the historical sense is somewhat elusive for most people, including those who have a mathematical culture, and, even more, is particularly difficult to define in the case of young students. In the case of secondary school teachers, it was noticed that for “decades if not centuries now, a few voices in each generation have urged the value and importance of using history in teaching mathematics—but so far, without this insight taking firm and widespread root in the practice of teaching” (Fauvel, 1991). More recently, Ball and colleagues explained the use of history as a part of their definition of horizon content knowledge. Ball et al. (2008) concentrated on “how teachers need to know that content” (p. 395) and they sought to “determine what else teachers need to know about mathematics and how and where teachers might use such mathematical knowledge in practice” (p. 395).

Boero and Guala (2008) used the notion of “cultural analysis of the content to be taught” (p. 223), that engaging in the mathematical, historical, and cultural aspects of a mathematical concept is an important way for teachers to know the content that they teach.

By posing historical problems and analysing the approaches by mathematicians of previous eras, students can better understand mathematical thinking and appreciate its dynamic nature (Po-Hung Liu, 2003). Some research showed the Role of the History of Mathematics in fostering argumentation (Gil & Martinho, 2015). In many of such studies, the content knowledge of students and knowledge of instructional strategies improved. In addition, the vertical links from content knowledge to several attributes of Pedagogical Content Knowledge (PCK), as well as the horizontal links among those attributes, were strengthened (Su & Ying, 2014).

In one study with Secondary School teachers, in-service teachers in China did work on Heron's formula. They used Veal and MaKinster's taxonomy to analyze teachers' productions to see how content knowledge grows. The authors reflect on different types of observations about growing PCK: (a) mathematical knowledge and the connection between content knowledge and socio-culturalism; (b) different representations and structures of proofs; (c) connection between the teachers' content knowledge and assessment; (d) connection between content knowledge and pedagogy; (e) students' possible difficulties and its connection with content knowledge and (g) connections among content knowledge, pedagogy, and curricula. Regular topics were analysed as Gauss systems for solving problems with three variables; second-degree equations, methods of measuring inaccessible lengths using similar triangles, etc.

We think that Primary teachers would not present the same kind of results. In Italy and Spain, young students, mainly women, who enter the university to become teachers, have an experience in math courses in compulsory and secondary school lasting about 12 years. This experience often involves feelings such as annoyance or

distress and a vision of mathematics reduced to pure calculation and mechanical procedures (Millán Gasca & Cleme, 2021).

Clark's study (2012) presents the results of research about how prospective mathematics teachers know the topics that they will teach and how that teaching might include a historical component. A few studies report on using the history of mathematics for Elementary students. For instance, "The Development of Place Value Concepts to Sixth Grade Students via the Study of the Chinese Abacus" (Tsiapou & Nikolantonakis, 2013) is based on studies about students' difficulties and the possible positive contribution of the history of mathematics – via the Chinese abacus – in place value understanding. Thus, students are expected to develop an understanding by exploring mathematical concepts empirically. It is imagined that they recognize the validity of non-formal approaches of the past. Students become aware that different people in different periods developed various forms of representations. They must perceive that mathematics was influenced by social and cultural factors. Also that they feel the need for pedagogical arguments: motivate emotionally-develop critical thinking and/or metacognitive abilities. The composing and decomposing activities on the abacus and their connection to the algorithms of addition and subtraction changed their perspective on the concept of the carried number. They explained it as an exchange between classes, verbally denoted or through a composing or decomposing example.

Didactically, it is essential to find and identify historical sources that are suitable for provoking discussion in classrooms among students and with their teachers about different meta-discursive rules. Likewise, it is crucial to perform research about how this can be done, how teaching activities that support such discussions and reflections can be designed, and how the effectiveness of such teaching and learning situations can be evaluated in practice (Kjeldsen & Blomhøj, 2012: pp. 347).

History shows that societies develop due to the scientific activity undertaken by successive generations and that mathematics is a fundamental part of this process. This way, mathematics could be presented to students as an intellectual activity for solving problems in each period. The societal and cultural influences on the historical development of mathematics provide teachers with a view of mathematics as a subject dependent on time and space and thereby add additional value to the discipline (Katz & Tzanakis, 2011). Regarding prospective elementary teachers, it is known that some of them have positive memories of mathematics. Despite this, they assumed that the mathematics they had studied was mechanical, with a lot of arithmetic and algebraic calculations. Although they had enjoyed them, the lack of real problems had made the subject useless in their lives. None of them mentioned reasoning or development of thought when speaking about the contributions that the study of mathematics had made to their global training.

Moyon (2017), based upon the French curriculum, giving a historical perspective to some mathematical contents (numeration, decimal numbers, Metric system, etc.), states that the use of history in Elementary education may contribute to identifying the pupils' own scientific culture. In the following parts, we present several examples of the use of history in preparation for Primary teachers. We base some of the experiences on the idea of exploring mathematics through history (Eagle, 1995).

## History Can Help Increase Motivation: Money Systems and Number Systems

For Primary Education, we consider the use of history, mainly in constructing big ideas to see how the fundamental ones arise as social constructions. We discuss how the history of number systems has been used, the historical evolution of maps, and the main issues about the history of probability, measurement ideas, ratio, and proportional problem solving, among others. The role of patterns and the analysis of mathematical meanings could be revealed.

Since the early years, it has been essential to analyze the role of complex issues and the big interdisciplinary ideas such as integrating geometries, parabolic motion, and others. It is also essential to explain examples about the limits of knowledge, integrate the analysis of social issues about mathematical ideas, and have tools for critical thinking and inquiry attitude. The importance of contextualizing mathematical knowledge is widely assumed since it is considered that context may be the key to relating to what psychologists have learned about how humans reason, feel, remember, imagine and decide what. On their side, anthropologists have learned about how meaning is constructed, learned, activated, and transformed. However, various studies show that there is a significant gap between the mathematics that is explained in school and that which people use in their daily lives. For Diez-Palomar (2004), the existence of this gap is one of the reasons that explain the negative attitudes that many people develop towards mathematics. It has been observed that in real-life situations, where people are cognitively, emotionally, and socially involved, they use 'their own' mathematics that, although it may be very different from that studied in school, generates the solution simultaneously with the problem.

Understanding one's sociocultural past, in addition to being an objective of the curriculum, can be a good resource for interpreting the present. Furthermore, as stated by Prats and Santacana (2009), the heritage — in this case, the local archaeological heritage of the city where the students live — has an identified and observable history that allows us a scientific approach to the past and has a high instructive and educational potential since it provides objective knowledge. According to Dean (2008), the student must proceed as if he were a young historian who constructs a specific vision of the past based on the complex interaction between two stories. The first story is the information frame the past has left for the historian to work on, and the second is where his life experience is completed (what you have read, what you know, etc.). In this case, who is the historian is the same students and, therefore, due to their age, this second story is relatively restricted; it is precisely on this restriction where the teacher plays an essential role since she is responsible for providing sufficient instruments to be able to alleviate this lack of experience by writing a second story.

The mathematical experience that is exposed is part of a task bank that was called "Living Baetulo," contextualized in the historical epoch corresponding to the Roman Empire and the process of Romanization of Catalonia, specifically, in the daily life of Baetulo (Badalona city close to Barcelona) between the 1st and 4th centuries BCE. It

is an example requiring an attitude of research. Potentially designed tasks could promote in students the need to investigate aspects related to numbering systems. The experiment was designed in 11 sessions, of approximately 50 minutes each, where students, starting from an archaeological report, had first to gather information to know the context of the task and then to be able to conjecture and formulate their hypotheses. In one of the tasks, students found the need to know the way the Roman monetary system worked to find the value of the coins. In this task, they studied other, more current monetary systems to build mathematical thinking around the idea of a numbering system. Then they searched information -through a blog created for this experiment- to assess whether the treasure represented, for whom it was hidden, a lot or a little money, since this would give them the necessary information about what type of person could be its owner.

The students who studied the system less known to them were forced to reason and discuss among themselves based on the information available they had to establish some of these less obvious relationships. With the reflection generated in the comparison of the monetary systems, students were able to connect information and make generalizations applicable to other systems and, specifically, to the decimal number system and the metric system.

In a special session of reviewing and discussing the information obtained from the visits of the previous session, they emphasized knowing the houses of Baetulo to be able to make a conjecture as to whether the treasure house belonged to a rich or poor owner.

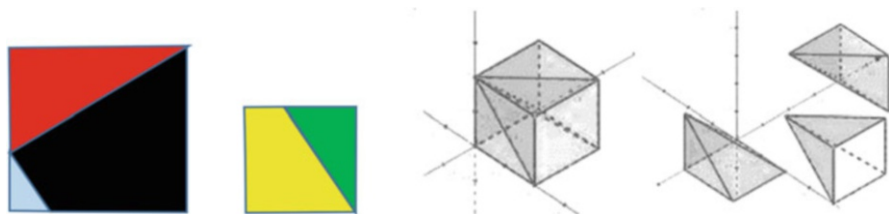
As a first conclusion of such experience, we can affirm that the nearby historical-cultural context is motivating since it allows the connection of mathematics with the close reality of the students. This context promoted thinking about relevant mathematical questions since it has generated among the students the possibility of contemplating new points of view about the content -proportion, systematization, etc.- that has led them to discover new patterns – the relational structure of the monetary system similar to that of the numbering system, the use of subtraction in sales relationships, etc.

## **Recognizing Students' Difficulties: The Liu Hui Decompositions Example**

Geometric education should begin in kindergarten or primary school, where the child should acquire familiarity through the senses with simple geometric forms by inspecting, drawing, modelling, measuring them, and noting their more obvious relations (NCTM, 2000). On the other hand, the activity of classifying is one of the essential characteristics of any branch of human thinking and, in particular, a fundamental activity in mathematics. Guillén Soler (2005) argues that to determine types of classifications, it is necessary to have taken into account the criteria used to classify the universe.

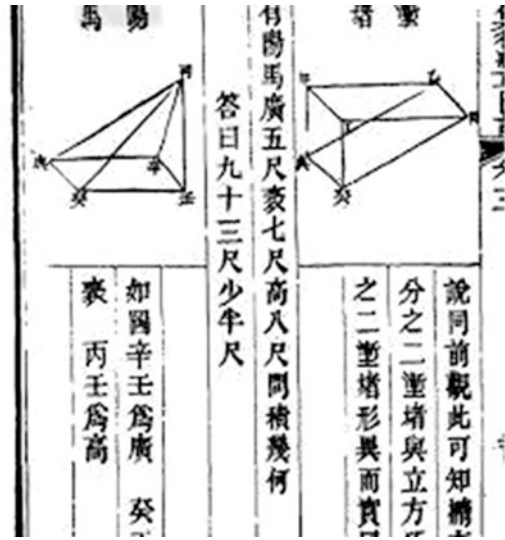
Students have difficulties in classifying polyhedral. Research has reported that students usually have learning difficulties in 3-D shapes (Ng et al., 2020). Students take a partial look at the figures to determine the families of polyhedral, paying particular attention to the face shapes of the polyhedron, if the polygons that make it up are regular equal or not, if they are oblique, in general, they do not make a global look of the polyhedral to determine families. One of the difficulties found by students and future teachers is related to the construction of nets. Net construction requires students' ability to do translations between 3D objects and 2D nets by focusing and studying the parts of the objects in both representation modes. In particular, they have difficulties recognizing sections of 3D figures (Cohen, 2005). Some authors supported that the visualization of nets involves mental processes that students do not have but can develop through appropriate instruction. Some of these difficulties start in mathematics textbooks (Zang, 2021). Students have difficulties in (1) recognizing the types of 2-D and 3-D shapes, (2) drawing the 2-D and 3-D shapes, (3) counting the edges of the shapes, (4) identifying the types of straight, curved, and number of shape surfaces, (5) drawing the 3-D shape net, and (6) combining the basic shapes in a net. Ng et al. (2020) summarized that students always relied too much on the perceptual attributes of 3-D shapes and failed to decompose any shape into its basic elements and identify its properties. Therefore, we propose a task in which future teachers construct figures and relate such knowledge with the history of mathematics. In the present section, we want to explain that this content provides enough opportunities for students to learn geometry to the caster for individual differences and acquire spatial ability.

Liu Hui's Cube Puzzle has been successfully used with more than 12 classes of prospective elementary teachers in the teacher education program at Southern Illinois University Carbondale and several groups of in-service teachers at in-school professional development workshops in southern Illinois (Bu, 2017). In our case, we introduced Liu Hui mathematics framework to compare the plane scheme of the Pythagorean rule and cube dissection. Both schemes are dissection and composition problems. From such a perspective, we want to reflect on the need to compare 2D and 3D figures and relate it to the history of mathematics, at least for elementary teachers, as we observe in the figure.



Comparing Plane Tangram with volume decomposition both used by Liu Hui





Observing Chinese representations of half and third of a cube

We introduced three important Chinese terms used in his description, *quiandu*, *yangma*, and *bie'nao*. Moreover, how does the *bie'nao* (triangular pyramid) compare with the *yangma* in terms of volume? To analyse the volume of a *yangma* (rectangular pyramid) that results from such a dissection was difficult. However, the heaviest difficulty is to see that you need two different symmetric figures of the sixth to have the third.

In a first pilot experience done at Lleida University, we used only several *quiandu* pieces (four half cubes). After the experience, some interesting answers were collected.

I thought the cube puzzle was fun and a great way to get my brain cranking and develop ideas on how to form the cube. It was not very difficult for me, but I could see it being a challenge for children and a great learning experience when learning about 3D objects and geometry... It was interesting when the trainer explain the possibilities of classifications from this material. (Future teacher Mary, October 14, 2020).

Now, I see a way to present the number relations among 3D figures. It is easy to recognize that adding two shapes is equal to another one. It means something similar to what we observe with tangram. I never thought that such observations were so old. (Future teacher Marta, October 14, 2020).

If we create problems like these to give our pupils a good grounding in this topic, equipping them with complementary knowledge and skills, then perhaps three-dimensional problems will never become 'hard and scary' at all. (NRICH comment, 2004).

## Developing Students' Mathematical Thinking: Problem Posing

We assume the need for having tools for semantic analysis of problem-solving using the Pólya principles. Pólya indicates that understanding how the human race has acquired knowledge of specific facts or concepts puts us in a better position to judge how a human child should acquire such knowledge. On the one hand, these are relevant for orienting and preparing students for later study, as well as transmitting essential aspects of the human cultural heritage to new generations. Bartolini Bussi (1996) explains how students express the 'voice' of Piero Della Francesca during a primary school perspective drawing activity. Ernest says, "Mathematicians in history struggled to create mathematical processes and strategies which are still valuable in learning and doing mathematics" (1998, p. 25).

For example, consider the teaching experiment reported in Boero & Garuti, 1994. Students were asked to produce a brief, general statement about the relationships between heights of objects and the length of sun shadows they cast; they were subsequently asked to compare their statements with the official statements of the so-called 'Thales theorem.' Analysis of the students' texts revealed an interesting phenomenon: many students had tried to rephrase their statements to make them resemble the official statements or to rephrase the official statements to make them resemble their own.

One interesting task for prospective elementary teachers to promote mathematics thinking is presented as follows: (1) Search and selection of news; (2) Analysis and discussion about the potential that the news has to address mathematical notions; (3) Curriculum analysis on mathematical content and processes; (4) Initial project of school activities; (5) Configuration of the overall proposal; (6) Reflection on the planning and designing process; and, (7) Public presentation of the didactic sequence developed.

In many of the comments analysed, the culture and identity of social groups appear as an element to be considered or education in values like the theme of hunger. In others, there is a search for interdisciplinary topics with a training component for citizenship. Most topics are of scientific origin: the ecological (drought, animal abuse, etc.), health (the sugar we eat, what we should be up to date, etc.). Also, appear one hundred cases in which there is an artistic and historical context (painting, architecture, etc.) or issues of social origin, such as handling press information. It should be called an actual historical problem, but it is considered possible to have a set of problems (Vanegas & Giménez, 2018).

When the students were asked to find arguments for the value of this news, prospective teachers told us, "The main reason we believe that teammates selected this news is because it is a global problem that affects many people in the world". The prospective teachers could propose questions relating proportions to non-experienced units related to hunger problems. Nevertheless, it does not mean a deep understanding of the conventionalism of length measurement. Prospective teachers recognize that, when dealing with a problem, it allows not only

interdisciplinary connections but also connects mathematical notions. When describing the competencies studied, in the case of the proposal on hunger in the world, there is a much better description than the initial one, in which the relationship between context and content that we understand by connection is carefully explained as a mediator.

## Obstacles in the Development of Mathematics: The Case of Unit Measurement

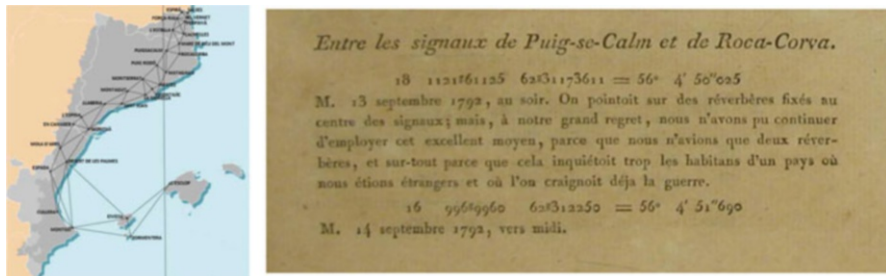
During the development of mathematical ideas, mathematicians slowly recognized certain concepts. It is reasonable to assume that today's students would also encounter difficulties when they begin to learn these concepts. As an example, we know the difficulty of children to understand why it was only in the XIX century that people considered having a common conventional unit. Lehrer (2003) put focuses on the measurement process and focuses on the units, putting forward eight ideas needed to understand measurement. Exploring children's errors when they measure with a ruler is one of the most interesting aspects of analysing children's knowledge of that instrument during their school years. Gomezescobar et al. (2020) studied the difficulties of preschoolers with understanding conventional units. Other authors relate such difficulty in the early years (Barrett et al., 2012; Sisman & Aksu, 2016).

The school activity was implemented by observing a monument in Glories' square in Barcelona (Vilella, 2018) with 6th graders (10–11 years old students) (Fig. 11.1 right). We explain to future teachers how in every town, there was an official unit for measuring textiles. We present the image to the old representation of "canador" (person who uses the official length for measuring) in the front door of Barcelona, as it is represented in a gravure observed in a public fountain near one of the old doors of Barcelona town (Fig. 11.1, left).

It promotes to reflect on the use of different lengths of non-conventional units. It is the moment to talk about the different units as the use of span or foot, "vara, toesa, vara, or the width of chariots. . . We show the method of triangulation used to find the measurement of the meridian from Dunkerke to Barcelona (figure right). The



**Fig. 11.1** The image of canador in a tile. (left) Image of the meridian profile



**Fig. 11.2** Triangulation in Catalonia (left) Explanation of measurements

monument was a gift from the city of Dunkerke to the city of Barcelona. After that, we discuss the last triangle used to find the measurement. Giving the students some of information about different measurements, we want to keep in mind the non-conventional.

Vara from Pallars	0.778 m
Vara from València & Castelló	0.906 m
Vara from Xàtiva & Alacant	0.912 m
Vara from Terol	0.768 m

We note that it would be a good business to buy fabric in Castelló and sell it, at the same price, in Terol. Since Terol’s ‘Vara’ was shorter, we would make a profit of 18%.

It is explained the process of triangulations (Fig. 11.2 left) and the difficulties found in schools. For instance, the text in the Fig. 11.2 (right), indicates that they could not undertake the luminous signals because they only had two and, above all, because this worried the inhabitants of the country in which they were foreigners and where the war was already feared (it refers to the war with France that would break out a few months later, at the beginning of 1793).

In Barcelona classrooms, the teacher talks about the triangle used in Barcelona (Fig. 11.3 left), the streets called “Parallel and Meridian,” and the intersection of the tower of the clock. This point was used with the citadel and Montjuic Mountain as one of the triangles during the measurement (Fig. 11.3).

Such an experience could be improved with a more sophisticated experience by discussing the use of the pendulum as a way of looking for a deep understanding of mathematics and physics. An experience like that was organized with 11th graders in Greece to see in depth the arguments about arbitrary and conventional measures, connecting the conventional unit of length measurement with justice. The social conditions were presented as decisive for making decisions, while at the same time, the ethical responsibility of scientists as active members of society came to the fore (Kotarinou & Stathopoulou, 2015). The teaching experiment entitled “Is our world Euclidean?” was drama-based teaching of the process of axiomatic definition of Euclidean and Non-Euclidean Geometries interrelated to the history of Euclid’s 5th



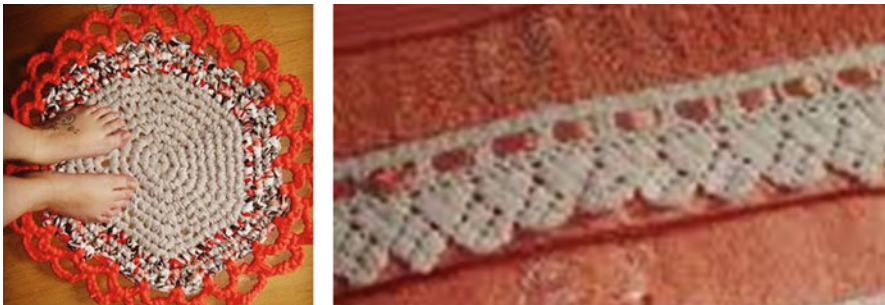
**Fig. 11.3** The triangle measured at Barcelona, and the position of meridian and parallel

postulate. Our research reveals considerable evidence for the effectiveness of drama techniques as an alternative approach to creating appropriate learning conditions, activating all students as evidenced by their participation, and contributing to their development as critical citizens.

## Humanistic Facets of Mathematical Knowledge: Isometries in Kosovo and Spain

The students can reflect on the cultural recognition of geometry present in a cultural comparison perspective based on observing the use of popular embroideries.

The example of drafts (“calados” in Spanish) from Canary island (Balbuena et al., 2000) to identify isometries in Secondary school classes inspired us for a more general study made by Prospective Primary teachers. The activity starts with the video explained by Luis Balbuena (<https://www.youtube.com/watch?v=4OzYJukau04>). It is in the framework of the work of isometries (movements of a figure that conserve the same shape). The use of this example in a session for talented students can be observed in Spanish in the following document. (<https://www.estalmat.org/archivos/CaladosCanarios.pdf>). In the figures, we see the example of similar techniques of embroideries in Catalonia.

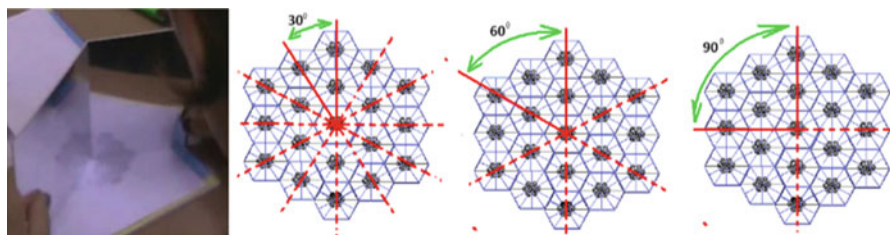


Comparing embroideries in Catalonia (left side) and Kosovo (right side)

Also, in Kosovo, it is possible to observe such ideas with typical embroideries. Such images, based on historical techniques of embroidery and knitting, produced a wide range of motifs that demonstrate a unique way of transformation and movement across plane and space. The activities have been performed in regular classrooms of the Faculty of Education of Kosovo and Barcelona (Spain). In the group, there were 18 students in the 3rd grade of the study program primary education. Some other questions were added to identify reasoning and specific cultural elements about geometric transformations, ideas about teaching and learning, and their thinking about future classrooms teaching geometrical transformations. Students came to the final test after taking a training course about teaching geometric transformations in the school during the spring semester of 2013. Students received a questionnaire on the last day of the course, and all students responded to the questionnaire. The issue in focus was the identification of the prospective teachers' concept images and the way they used their images, and the mathematical definition of specific concepts for geometric transformations that they will find central when they begin their professional life as mathematics teachers.

We present now the analysis of the moments of progress or difficulties of the student for future teachers of Primary school; in the process of building the idea of geometrical transformation, that fig. A is transformed in fig. B and the usage of the adequate terminology in every case and identification of different types of transformations. Few students talk explicitly about isometries as transformations that conserve size and shape. Instead, they identify the symmetries, rotations, and translations as transformations with such property. In some cases, the activity makes the intuitive go ahead with the structured knowledge. In that way, when we are in front of the observation of the embroidery, some students show rotation as a unique isometry since they identify it as the only transformation that acts on the module that is marked (Fig. 11.4). So, the conceptual image of the geometrical transformation is built based on visual properties (transform = deform) and movement (Isometric = displacement).

The classification of patterns by symmetry provides a systematic technique for studying the role and meaning of design in a cultural context. Although many hand-made created and manufactured patterns are not exact in their symmetry, a closely balanced pattern is considered symmetrical and can be examined with symmetry analysis.



**Fig. 11.4** Future teachers analyze rotational embroideries by using mirrors

We found difficulties interpreting isometries as an action on a set of points, even using a close environment for mathematical ideas. Only one of the participants talks about isometric transformation as a transformation that conserves shape and size – conservation of shape and size is the definition of isometry, while the others identify it as a repetition – which is associated with difficulties in identifying properties of transformations. We find that considering transformations with identifying invariants (form and size) is a better level than considering transformations as simple repetitions.

A deep understanding of embroideries could be analyzed using an ethnomathematical theoretical background in the Bedouins' culture (Katsap & Silverman, 2016).

### Empirical vs. Metaphorical Observations. The Case of Geometrical Reasoning



When doing an initial activity about connecting the real world to Mathematics, prospective teachers do not identify a historical framework as a context for developing mathematical problems.

It was proposed to formulate problems relating to several images. One of them was the oldest known example of applied geometry, dating back 3700 years ago.

Daniel Mansfield (2021) explains that “It’s the only known example of a cadastral document from the OB period, which is a plan used by surveyors to define land boundaries. After explaining, future Elementary teachers could state that they would never discover it only by looking at the picture. The idea of having a relation between such a tablet and Plintom 322, telling us about Pythagorean triplets, recovers the argument suggesting the Babylonians beat the ancient Greeks to the invention of trigonometry by over 1,000 years. Future teachers remember their knowledge about trigonometry, at least “to understand trainer explanations.”

## Final Considerations

Learning mathematics through its historical development is essential not only from a cultural and humanistic perspective, but also because it facilitates understanding its contents. In this chapter, we exemplify the need for empowering future teachers about the role of mathematics in interpreting social events. Training mathematics should not start at the final stage: the passive assimilation of abstract concepts and their correlations. It should be the students themselves who obtain a general notion. This is how to return to the initial moment of a scientific proposition. The role of manipulative and computational mediators using historical frameworks is also discussed.

As teacher educators and researchers, we aim to explain how pre-service teachers learn to interpret teaching situations. The challenge is defining how to analyze the learning of this competence. Integrating history into school mathematics curricula not only helps improve students' attitudes and enhance higher-level thinking but also helps expand teachers' understanding of the nature of mathematical knowledge.

Observations so far suggest that available or suggested sign systems strongly influence accumulating and deepening phenomena at an individual level. As to 'multiple echoes', we think that familiarity with collective discussion (where students carry out the social construction of knowledge) is a necessary condition but not sufficient for generating this type of echo.

Based on the findings of this study, it is recommended that mathematics educators in particular, and teachers in general, consider the epistemological and cultural approach in the design and delivery of instruction.

**Acknowledgments** This study has been carried out as part of the projects: PID2019-104964GB-I00 (MICINN) / PGC2018-098603-B-I00/ 2017-SGR-101 y 2017-SGR-1353.

## References

- Balbuena, L., De la Coba, D., & Garcia, E. (2000). Calados canarios y matemáticas. *Suma*, 35, 5–14.
- Ball et al. (2008). Content knowledge for teaching: What makes it special? *Journal of Teacher Education*, 59(5), 389–407.
- Barrett, J. E., Sarama, J., Clements, D. H., Cullen, C., McCool, J., Witkowski-Rumsey, C., et al. (2012). Evaluating and improving a learning trajectory for linear measurement in elementary grades 2 and 3: A longitudinal study. *Mathematical Thinking and Learning*, 14(1), 28–54. <https://doi.org/10.1080/10986065.2012.625075>
- Bartolini Bussi, M. (1996). Mathematical discussion and perspective drawing in primary school. *Educational Studies in Mathematics*, 31, 11–41. <https://doi.org/10.1007/BF00143925>
- Bartolini Bussi, M. (2000). Ancient instruments in the modern classroom. In J. Fauvel & J. Maanen (Eds.), *History in mathematics education: The ICMI study* (pp. 343–350). Kluwer Academic publishers.
- Boero, P., & Garuti, R. (1994). Approaching rational geometry: From physical relationships to conditional statements. In *Proceedings of PME-XVIII* (Vol. 2, pp. 96–103). PME.



- Boero, P., & Guala, E. (2008). Development of mathematical knowledge and beliefs of teachers: The role of cultural analysis of the content to be taught. In P. Sullivan & T. Wood (Eds.), *The international handbook of mathematics teacher education* (Vol. 1, pp. 223–244). Sense.
- Bu, L. (2017). *Exploring Liu Hui's cube puzzle: From paper folding to 3-D design*. Convergence.
- Clark, K. M. (2012). History of mathematics: Illuminating understanding of school mathematics concepts for prospective mathematics teachers. *Educational Studies in Mathematics*, 81, 67–84. <https://doi.org/10.1007/s10649-011-9361-y>
- Cohen, C. (2005). The influence of spatial ability on the use of a dynamic interactive animation in a spatial problem solving task. In T. Barkowsky, C. Freksa, M. Hegarty, & R. Lowe (Eds.), *Reasoning with mental and external diagrams. Computational modeling and spatial assistance*. American Association for Artificial Intelligence Press.
- Dean, J. (2008). *Ensenyar història a Primària*. Zenobita edicions.
- Diez-Palomar, J. (2004). *L'ensenyament de les matemàtiques en l'educació de persones adultes*. Tesis doctoral no publicada. Universitat de Barcelona.
- Eagle, R. (1995). *Mathematics through history*. Cambridge University Press.
- Ernest, P. (1998). A postmodern perspective on research in mathematics education. Mathematics education as a research domain: A search for identity: An ICMI study book 1. *An ICMI Study Book*, 2, 71–85.
- Fauvel, J. (1991). Using history in mathematics education. *For the Learning of Mathematics*, 11(2), 3–6. <https://www.jstor.org/stable/40248010>
- Fried, M. N. (2001). Can mathematics education and history of mathematics coexist? *Science & Education*, 10(4), 391–408. <https://doi.org/10.1023/A:1011205014608>
- Gil, P., & Martinho, M. H. (2015). The role of history of mathematics in fostering argumentation: Two towers, two birds and a fountain. In K. Krainer & N. Vondrová (Eds.), *Proceedings of the ninth congress of the European Society for Research in Mathematics Education* (pp. 1817–1824). Charles University in Prague, Faculty of Education and ERME.
- Gomezscobar, A., Guerrero, S., & Fernandez, R. (2020). How long is it? Difficulties with conventional ruler use in children aged 5 to 8. *Early Childhood Education Journal*, 48, 693–701. <https://doi.org/10.1007/s10643-020-01030-y>
- Guillén Soler, G. (2005). Análisis de la clasificación. Una propuesta para abordar la clasificación en el mundo de los sólidos. *Educación Matemática*, 17(2), 117–152.
- Katsap A., & Silverman F. L. (2016). Transformations, shapes and patterns analysis in the Negev Bedouins' embroideries. In *Ethnomathematics of Negev Bedouins' existence in forms, symbols and geometric patterns*. SensePublishers. [https://doi.org/10.1007/978-94-6209-950-0\\_6](https://doi.org/10.1007/978-94-6209-950-0_6).
- Katz, V., & Tzanakis, C. (Eds.). (2011). *Recent developments on introducing a historical dimension in mathematics education*. The Mathematical Association of America.
- Kjeldsen, T. H., & Blomhøj, M. (2012). Beyond motivation: History as a method for learning meta-discursive rules in mathematics. *Educational Studies in Mathematics*, 80, 327–349.
- Kotarinou, P., & Stathopoulou, C. (2015). Using drama techniques for facilitating democratic access to mathematical ideas for all learners. In U. Gellert, J. Gimenez, C. Hahn, & S. Kafoussi (Eds.), *Educational paths to mathematics* (pp. 323–340). Springer.
- Lehrer, R. (2003). Developing understanding of measurement. In J. Kilpatrick, W. G. Martin, & D. Schifter (Eds.), *A research companion to principles and standards for school mathematics* (pp. 179–192). National Council of Teachers of Mathematics.
- Liu, P.-H. (2003). Connecting Research to Teaching: Do teachers need to incorporate the history of mathematics in their teaching. *The Mathematics Teacher*, 96(6), 416–421. <https://doi.org/10.5951/MT.96.6.0416>
- Mansfield, D. F. (2021). Plimpton 322: A study of rectangles. *Foundations of Science*, 26(4), 977–1005.
- Millán Gasca, A., & Cleme, E. G. (2021). *Integrating history of mathematics with foundational contents in the education of prospective elementary teachers*. <http://dml.mathdoc.fr/item/hal-01349254/>

- Moyon, M. (2017). Teaching mathematics and algorithmics with recreational problems: The Liber Abaci of Fibonacci. In É. Barbin, U. T. Jankvist, T. H. Kjeldsen, B. Smestad, & C. Tzanakis (Eds.), *Proceedings of the Eighth European Summer University on History and Epistemology in Mathematics Education (ESU-8)* (Skriftserie 2019, nr 11) (pp. 417–436). Oslo Metropolitan University.
- National Council of Teachers of Mathematics. (2000). *Principles and standards for school mathematics*. NCTM.
- Ng, O., Shi, L., & Ting, F. (2020). Exploring differences in primary students' geometry learning outcomes in two technology-enhanced environments: Dynamic geometry and 3D printing. *International Journal of STEM Education*, 7, 50. <https://doi.org/10.1186/s40594-020-00244-1>
- NRICH comment. (2004). *Thinking 3D*. <https://nrich.maths.org/2392>
- Prats, J., & Santacana, J. (2009). La ciudad, un espacio para aprender. *Aula de innovación educativa*, 182, 47–51.
- Sisman, G. T., & Aksu, M. (2016). A study on sixth grade students' misconceptions and errors in spatial measurement: Length, area, and volume. *International Journal of Science and Mathematics Education*, 14, 1293–1319. <https://doi.org/10.1007/s10763-015-9642-5>
- Su, J. H., & Ying, J. M. (2014). Enhancing in-service mathematics teachers' professional knowledge with an HPM approach as observed in teachers' reflections. *Taiwan Journal of Mathematics Education*, 1(1), 79–97. <https://doi.org/10.6278/tjme.20140307.003>
- Tsiapou, V., & Nikolantonakis, K. (2013). The development of place value concepts to sixth grade students via the study of the Chinese abacus. In B. Ubuz, Ç. Haser, & M. A. Mariotti (Eds.), *Proceedings of the eighth congress of the European society for research in mathematics education* (pp. 2058–2067). Middle East Technical University and ERME.
- Vanegas, Y., & Giménez, J. (2018). Conexões extramatemáticas na formação inicial de docentes. *Estudos Avançados*, 32, 153–169.
- Vilella, X. (2018). La història com a context per a l'enriquiment competencial de l'activitat matemàtica. *Noubiaix: revista de la FEEMCAT i la SCM*, 43, 36–50.
- Zang, P. (2021). Opportunities to learn three-dimensional shapes in primary mathematics: The case of content analysis of primary mathematics textbooks in Hong Kong. *EURASIA Journal of Mathematics, Science and Technology Education*, 17(6), em1971. <https://doi.org/10.29333/ejmste/10884>

# Chapter 12

## Recent Trends of History of Mathematics Teacher Education: The Iberic American Tradition



Joaquín Giménez and Javier Díez-Palomar

**Abstract** This chapter intends to analyze the recent evolution of the Teacher Education programs themselves, the proposals relating to knowledge and practice, the noticing approach, the didactic phenomenology or the ontosemiotic approach, the anthropological perspective, sociocultural and critical perspectives, among others other general theoretical frameworks. In addition, the chapter focalizes the Iberoamerican tradition less analyzed by the English influence but participating as an international perspective. Also, future perspectives are recognized.

**Keywords** History of mathematics · History of teacher education · Teacher education · Teacher knowledge · Iberoamerican tradition

### Introduction

This chapter analyses the evolution of the research about teacher training programs and research proposals developed in the study, mainly focusing on mathematics teacher education from a historical point of view. We do not focus on using history as a resource for teaching but on exploring how mathematics teacher education has evolved in the last decades, resulting from a historical development process.

Two facts mark the emergence of the new status of Teacher Mathematics Education (TME) as a research agenda within Mathematics Education (M.E.) as a scientific discipline: (a) the importance of teacher educators in the field, and (b) the presence of teacher-researchers in international forums. Many studies have been published in the *Journal of Math Teacher Education* and the *European Journal of Teacher Education*, and other scientific sources, including *CIEAEM Conferences*. Such organisation consolidates the role of teachers as teacher-researchers.

---

J. Giménez · J. Díez-Palomar (✉)  
Department of Didactics of Experimental Science and Mathematics, Faculty of Education,  
University of Barcelona, Barcelona, Spain  
e-mail: [quimgimenez@ub.edu](mailto:quimgimenez@ub.edu); [jdiezpalomar@ub.edu](mailto:jdiezpalomar@ub.edu)

In the last decades, there has been considerable development of the TME. After a first period (1968–2000) in which the research was focused more on students, it started a new period centred on teaching and teacher development.

The year 2000 increased the reflection about the role of Mathematics in schools, also giving opportunities for the preparation for the new role of teachers in society. The ICMI community was ready to receive the message of Ubiratan D’Ambrosio (1986) at ICME-5, which introduced sociocultural dimensions into mathematics education and acknowledged the dignity of various forms of mathematical culture. It started the *Renaissance period* (Furinghetti et al., 2008). In CIEAEM63 (Barcelona), D’Ambrosio delivered one of the keynotes. He encouraged the training of future teachers capable of arousing interest in mathematics as a tool to improve the well-being of the entire society (D’Ambrosio, 2011).

Before that, it was a lack of international communication regarding mathematical education basically because many differences appear concerned the contents of instruction and the epistemology of school mathematics and the methodology of teaching.

In many countries, the training of teachers has become a more professional perspective. The inclusion of an official preparation of teachers in the Universities, leaving the old practice in separated colleges or “escuelas normales”, introduced a theoretical and specialized preparation on M.E. (Sierra, 1995). A critical moment was the publication of a collection of a series called “Mathematics Teacher Education” and the definitive inclusion of Teacher Education as an important point in the international agenda. The book “Learning through Teaching Mathematics, edited by Leikin and Zazkis (2010), was also a significant challenge trying to change the regular perspective of observing others to a new view of self-reflection.

## Theoretical and Historical Aspects

The changing conditions for the preparation of teachers in a common European framework, and internationally promoting exchanges among prospective teachers and teachers themselves, increase the interest in Teacher Education. The influence was noticeable in the themes and contributions to international meetings. The year 2000 promoted research interest in M.E. from a broader international audience: colleagues from non-industrialized and socialist countries and primary and secondary school teachers. Shifting from a concentration on content and methodological questions in mathematics, new themes were included in the research agenda, such as broader epistemological, psychological, sociological, and technological problems.

The teacher’s professional problems create links between scientific knowledge and craft wisdom, reinforcing the collaboration of mathematics education research and practice. Many questions arise from that perspective: What are the strategies in research and practice that support the development and provide essential and appropriate teaching and learning opportunities that ensure access to all levels of institutionalized schooling in elementary, secondary, higher education, and adult

education? How to create appropriate social conditions to establish a teaching and learning practice guided by social justice and equity principles?

The insufficient learning opportunities and a lack of transparency of the assessment system mainly concern mathematics as the prominent means of selection in the educational system. Education is in danger of being no longer perceived as a public duty or vital public service. TME should share a common aim: to train future teachers for equity and mathematics for all. TME should support adult education as a critical force for democratization and change in such a framework. It means a new way of seeing Mathematics teacher preparation for all.

The importance is given to training on practice, and from practice is considered. Likewise, collaborative intervention in research on teacher training is also considered. The proposals are analysed according to the need for a more significant link with school practice, the need for programs that face interdisciplinary visions, the tension between globalized training in the pre-K, kindergarten, and primary stages, and specialized postgraduate training in secondary education. The role and analysis of general or specific professional competencies are recognized among the new topics. The new views refer to professional identity, analysis of the holistic nature of specialized knowledge, the incorporation of research results, the essence of practical knowledge, including the history of mathematics in initial training, special needs, etc.

Concerning the curriculum for Teacher Education, the content matter should be extended to subjects too complex for treatment in traditional instruction, and application and problem-solving a much more appropriate simulation of reality is possible. By far less evident is how mathematics education should respond to the change in the notion of reality: the blending of the real and the virtual worlds, the loss of reliable discrimination of reality, and its manipulation. A tremendous problem emerges from the fact that the new technologies open up unprecedented chances and risks in various fields like biotechnology and military development, based on models and simulations beyond theoretical comprehension and beyond the validity of existing empirical knowledge. No attempts have been made so far to furnish reliable intellectual and moral basis equipment to the coming generations that inevitably will have to deal with these challenges (CIEAEM, 2000).

The following sections present different approaches from the international perspective, putting a particular accent on the research done in the Iberic American countries. Therefore, we focus on: (1) cognitive and epistemic aspects, (2) preservice teacher development at different levels, (3) knowledge and practice of mathematics teacher education, introducing lesson study and other frameworks, (4) anthropological and onto-semiotic perspective studies, (5) identity of teachers, attitudes, and beliefs; (6) critical issues and ethnomathematics studies, and (7) the CIEAEM contributions to mathematics teacher training. Finally, new topics and future perspectives are described.

## Cognitive and Epistemic Aspects of MTE

In the last decades, several contributions have expanded the classic work done by Shulman (1986, 1987) on teachers' knowledge. This section exemplifies studies related to didactic-epistemological reflections, mainly done at the secondary level. Personal epistemologies refer to individuals' cognition of knowledge and the process of knowing (Pintrich, 2004). In Furinghetti (2000) work, it is argued that the history of mathematics may be an efficient element to provide students with flexibility, open-mindedness, and motivation for mathematics. She presented a historical presentation of 'definition'; it was developed with mathematics students who will become mathematics teachers. Furinghetti's work (2000) claimed the need to consider the cognitive dimension of the knowledge that mathematics teachers will need to teach their students. Later, it is recognized the importance of teacher educators as a learner (Krainer et al., 2014).

*Mathematics teachers'* knowledge has been a very prominent focus of attention in the last decades. Many of the studies introduced the analysis of mathematics knowledge on different topics. From such a perspective, it is found the work about specialized mathematics knowledge on topics such as divisibility (Almeida et al., 2021), three-dimensional figures (Vanegas & Giménez, 2021); logic (Alfaro et al., 2020), among others.

Ball and her colleagues (2008) expanded Shulman's model exploring more in detail the distinction between content knowledge and pedagogical content knowledge (PCK), adding new concepts (common content knowledge, specialized content knowledge, and horizon content knowledge; knowledge of content and students, knowledge of content and teaching, and knowledge of curriculum).

These proposals have been resonated in the Iberic American context (Contreras et al., 2017; Montes et al., 2013; Pinto Sosa & González Astudillo, 2008). In 2020 the University of Huelva organized the IV Congreso Iberoamericano sobre conocimiento especializado del profesor de matemáticas [IV Ibero-American Congress on specialized knowledge of the mathematics teacher]. Members of the *Red Iberoamericana MTSK* discussed the relationships between the subdomains of PCK (Cabrera-Baquedano & Pezoa-Reyes, 2020).

However, the PCK model (and further developments, such as the ones by Ball et al.) have been criticized for being too static (Venkat & Adler, 2020). Opposite to this type of approach, frameworks focus on the developmental change in teachers' epistemologies (Feucht et al., 2017). Teachers change their beliefs, practices, and pedagogical knowledge while teaching over time or because of being exposed to new teaching evidence (further research studies, additional teacher training programs, etc.).

The team from Huelva in Spain expanded the PCK model toward an MTSK perspective (Carrillo et al., 2013a, b). Drawing on Ball et al. (2008) work, Carrillo and his colleagues expanded the original concept (PCK), including the specialized knowledge that mathematics teachers have (Montes et al., 2013; Flores et al., 2013; Carreño & Climent, 2009; Hill et al., 2008). According to them, mathematics

teachers have specialized knowledge emerging from their practice. Teachers need this specialized knowledge to conduct their lessons, which is different from the broader knowledge of mathematics that every mathematics user may have. The MTSK includes six subdomains of knowledge: three regarding the mathematics knowledge (M.K.): knowledge of themes (KoT), knowledge of the mathematics structure (KSM); and three regarding the pedagogical content knowledge: knowledge about the features of the learning mathematics (KFLM), knowledge about mathematics teaching (KMT), and knowledge about the mathematics learning standards (KMLS).

Rowland and his colleagues (2003) coined the *Knowledge Quartet*, focusing on analyzing teacher situations and introducing a model composed of four dimensions: foundation, transformation, connection, and contingency knowledge. This approach has also been used in the Iberic American tradition to provide examples for future teachers of using teachers' professional knowledge to reflect on teachers' practices (Martínez & Arévalo, 2017).

In August 2015, a group of researchers met at the Advanced Study Colloquium (ACS), funded by the EARLI (European Association for Research in Learning and Instruction), and introduced the 3R-EC framework: reflection, reflexivity, and resolved action for epistemic cognition. They discussed that teachers use the review to examine their practices to improve their future praxis. According to Feucht et al. (2017), teachers first reflect on a particular issue of concern. Then they engage in an internal dialogue including diverse structural, cultural and personal factors (as well as personal epistemologies) to finally make teaching decisions that will be enacted in the next opportunity (i.e., in their next lesson). Epistemic cognition refers to "how people acquire, understand, justify, change and use knowledge in formal and informal contexts" (Greene et al., 2016).

This dynamic view of teachers' competence to reflect (and change) their practices have been explored in the Iberic American region. For example, Zamorano (2015) discusses teachers' practices drawing on Rowland's concept of contingency situations. Solar and Deulofeu (2014) explore the contingency, focusing on how teachers justify their statements/claims within the classroom. Similarly, Martínez and Arévalo (2017) use the "knowledge quartet" model to analyze mathematics classes as a strategy for the professional development of primary education teachers.

## Preservice Teacher Development at Different Levels

The expression *teacher professional development* arises from the XXI century and tends to encompass the initial preparation with in-service research as a continuity. Therefore, some reflections about language contexts were emphasized for teacher education in the ICMI study held in 2005.

The agenda, in this case, argue on assumptions about classroom practice and preservice teachers' and school students' learning. There is still a discussion about theoretical frameworks and methodologies to discuss potentials and challenges. It

continues the reflection about analyzing representations and other mathematical processes.

Recent elaborations introduce the perspective of teachers' competencies resulting from the interaction between personal, situational, and social aspects (Blomeke et al., 2015).

In the case of preparation for secondary level, it is essential to conceptualize and measure knowledge in/for teaching mathematics, core features, basic abilities, and attempts of a normative approach. An unsolved question is what kind of knowledge is relevant for practice, and where and how do teachers learn this knowledge? It is also important how to implement the reflective practice, designing learning environments, changing perceptions, collaborative issues, inquiry learning environments, digital learning (Borba et al., 2016) environments, management issues, Self-efficacy, etc.

Among the different perspectives, many investigations relate to noticing competence in different levels (Llinares et al., 2016; Brown et al., 2020; López, 2021; Tekin-Sitrava et al., 2021; Amador et al., 2021; Dindyal et al., 2021) and study of learning trajectories (Burgués & Giménez, 2007; Ivars et al., 2019) mainly for Primary Teachers; Bernabeu et al., 2021).

Also, to understand opportunities for learning measurement (Callejo et al., 2021) and how prospective early childhood teachers try to instrument a learning trajectory (Moreno et al., 2021) and use the noticing approach as a research-based design for early reasoning (Vanegas et al., 2021).

## **Knowledge and Practice of Mathematics Teacher Education**

Borko and Potari (2020) have pointed out that 'knowledge for teaching' comprises 'subject matter knowledge and "pedagogical matter knowledge." There is an increasing "polarization" between practitioners and researchers in many countries and mathematicians and mathematics educators. Politicians find this an attractive situation and take advantage of it by using the division to minimize academic "interference" in their agenda for education, for example, in a further back-to-basics approach (CIEAEM, 2000).

Sfard (2004) qualified a new period as "the era of the teacher" due to researchers' uncontested focus on teachers. Such attention is also represented in the launching in 1998 of an international journal dedicated to mathematics teachers' education, the *Journal of Mathematics Teacher Education*. Questions about what teachers need to know and be able to do and how they develop their knowledge, skills, and beliefs have become central to the mathematics education research literature.

In some sense, "mathematics teacher educator" suggests a focus on academics only. This may be true for those countries/regions where MaTED is mainly at universities. But there are countries/regions where MaTED takes place within the instruction system or in teacher education institutes independent of universities.



The recently launched ICMI Study 25 (co-chaired by Potari & Borko) focuses on the idea of mathematics teachers learning through collaboration in schools or larger communities, drawing on an ICME-13 survey team by Robutti et al. (2016). Collaborative groups may be teams, communities, schools, and other educational institutions, professional development courses, local or national networks. This means that mathematics teacher educators can work in formal or informal groupings, in either face-to-face or distance settings. In addition, they can be facilitators such as trainers, coaches, or mentors. Given the variety of ways mathematics teacher educators can work and the different settings they can operate, many papers are needed to identify how to handle these professionals.

## Anthropological, Historicist, and Onto-Semiotic Approaches

Recently, new topics have arisen, such as the so-called ecological aspect and analysis of restrictions, which allows us to analyse the so-called study and research paths from the Anthropological Theory of Didactics. Sustainability in training processes, comparative studies, distance training models, and new integrative analyses of the social with the linguistic in analysing processes in initial or in-service teacher training. The role of reflective methodologies such as Lesson Study is now recognized. Also, issues related to social justice, the use of democratic debates, and the analysis of training for citizenship in teacher training. The critical view of Mathematics Education is also analysed regarding teacher training in recent years. It also points to the role of the specific analysis of textbook proposals, homework, analysis of interactions, and other curricular materials.

The origin of the Anthropological theory of didactic (the ATD) is the theory of the didactic transposition held by Chevallard (1991). At that time, Chevallard intended to describe and understand the lessons of mathematics taught by teachers in the classroom as the result of a process of “translation” of the mathematics itself, in the form of mathematics for teaching (which is not mathematics but a reformulation of mathematics in didactical terms). Drawing from this approach, many authors have contributed to the ATD framework (Bosch et al., 2011; Bronner et al., 2010; Chevallard, 2006, 2007; Ruiz-Higueras et al., 2007). Similar formulations also include the so-called “Joint Action Theory in Didactics” (JATD), drawing on Brousseau’s (1997) idea of didactic situations. According to the Anthropological perspective, *didactics* includes two main elements: the object of knowledge ( $O$ ) and the human being  $x$  who is studying  $O$ . In this sense, for researchers under this approach, the object of study is the system  $R(x, O)$ , where “ $R$ ” means the relations between  $x$  and  $O$ . This minimum system can be further expanded including the person who is teaching  $O$  ( $y$ ), as well as other people involved in the didactical situation (relatives, community members, etc.). The relation  $R(x, O)$  expands to  $R(x, y, O)$ , etc., creating a didactic system in which the general expression is denoted by  $S(X, Y, O)$ . The authors under this approach are aware of the restrictions/conditions the educational institution imposes on the system  $S(X, Y, O)$ . In every school, there is

a pedagogical approach of the centre, also influenced by the general standards (curriculum). Hence, in every case, the system  $S(X, Y, O)$  may look a bit (or significantly) different. In turn, the object of knowledge ( $O$ ) can also be expanded into different “layers”: the domain of the discipline (i.e., geometry), sectors, themes (or topics), and subjects.

The component that makes the system work is called *praxeology*. This component includes the *type of tasks* ( $T$ ); the *technique*  $t$  (*tau*), concerning a way of performing the tasks; the *technology*  $q$  (*theta*), referring to the way of explaining and justifying the technique  $t$ ; and the *theory*  $Q$  (*big theta*), that explains, justifies, or generates any part of the technology  $q$  that may be missing (or embedded). According to the ATD, the object of knowledge ( $O$ ) results in a combination of praxeologies ( $T, t, q, Q$ ).

The JATD introduces another critical aspect in the didactical analysis (to understand how teaching works): the relationship between teacher, student, and knowledge, based on what Ligozat and Schubauer-Leoni (2009) call *epistemic joint act*. According to them, teaching is an “action” in which the teacher teaches an object of knowledge to the student. In a similar vein, other authors (Sensevy, 2011) use the idea of the “Didactic game” as a metaphor to describe the interactions between teacher and student (as two players aiming at achieving the goal of the game, which is learning  $O$ ), as described in Chevillard and Sensevy (2014).

In the Iberic American countries, the Anthropological framework has been used in different contexts, such as integrating theories (Gellert et al., 2013), specific topics (Barbé et al., 2005; Corica & Otero, 2009; Quijano & Corica, 2017). We even found efforts of theoretical dialogue among different approaches, such as ATD and APOS (Bosch et al., 2017).

Radford (2013) proposes the *theory of objectification*. He introduces a more dynamic perspective in the didactical analysis based on a historicist point of view. According to him, “the goal of mathematics education is a dynamic political, societal, historical, and cultural endeavor aiming at the dialectical creation of reflexive and ethical subjects who critically position themselves in historically and culturally constituted and always evolving mathematical discourses and practices” (Radford, 2013, p. 8). Knowledge is constructed through doing, thinking, and reflecting, which is historically and culturally situated. Knowing becomes the actualization of knowledge. Learning is the social practice in which participants internalize that knowledge.

In a different vein, another contribution to the teacher training domain emerging from the Spanish scientific research, primarily echoed along with the Iberic American countries, is the onto-semiotic approach (OSA) (Godino et al., 2007). Initially, this perspective focused on the mathematical object. According to this approach, mathematics is a “socially shared problem activity, a symbolic language and a logically organized conceptual system.” (Godino et al., 2007, p. 129) People engage in *mathematical practices* when doing any mathematical activity (namely, solving mathematical problems or situations). When an individual is doing “mathematics,” s/he carries out certain shared social practices, and s/he uses particular instruments and tools. Recently, OSA relates very closely to ATD perspectives introducing a

prescriptive character of didactics (Godino et al., 2019). Researchers drawing on this approach tend to pay more attention to the systems of operative and discursive practices people use when solving mathematical tasks. These practices may be set up individually or defined/established by the institution (who is the “authority” determining what is right and wrong). Godino et al. (2007) distinguish among different types of institutional meanings: implemented, assessed, intended, and referential. Personal meanings include: global (personal practices that an individual can potentially carry out about a mathematical object), declared (what the individual does in fact), and achieved (personal practices fitting with the institutional meaning expressed by the teacher). Doing mathematics involves using mathematical objects. Godino et al. (2007) distinguish between language (terms, expressions, notations, graphics); situations (problems, extra or intra-mathematical applications, exercises, etc.); concepts (i.e., number, point, straight line, mean, function, etc.); propositions, properties, or attributes; procedures (operations, algorithms, techniques); and arguments (i.e., deductive, inductive, abductive, etc.) Godino et al., 2007, p. 130) Objects are organized into systems of practices. Teachers and students (or participants in the teaching-learning context) use semiotic representations (not just language but also other representations) to discuss the mathematical objects organized within systems of practice. According to authors working from this perspective, mathematical objects are organized in “configurations” that can be epistemic or cognitive. When individuals engage in primary mathematical processes (such as communicating, solving problems, defining, enunciating, elaborate procedures, arguing and/or justifying, etc.), they may use some of the above objects. Drawing on Wittgenstein’s (1953) concept of *language game*, Godino (2002) claimed that individuals’ interaction when doing mathematics might swing from personal to institutional, ostensive to non-ostensive, extensive to intensive, unitary to systemic and expression to content dimensions. The researcher needs to consider the duality (dialectally) among those binomials to analyze and understand what happens when a subject is doing mathematics.

Recent elaborations of this approach include a focus on didactical problems, practices, processes, and objects, including what is called “didactical suitability criteria (DSC).” (Breda et al., 2018). The DSC include six dimensions: epistemic, cognitive, interactive, mediational, emotional, and ecological. Researchers use them to analyze how fair is a particular mathematical practice (i.e., a lesson, an interaction in small groups, etc.), to design tasks for didactical analysis (Breda, 2021; Díez-Palomar et al., 2020; Giménez et al., 2013), to reflect on the meta-didactic knowledge of teachers (Breda et al., 2017), to push prospective teachers to develop their didactical suitability analysis competence (Giacomone et al., 2018). In addition, some recent studies suggest connections between DSC and other well-known teaching constructs, such as the “lesson study” (Hummes et al., 2019). Other examples of how this approach is being used (and expanded) among Ibero-American countries include assessment (García Marimón et al., 2021), analyzing self-regulation practices (Hidalgo Moncada et al., 2021).

## Identity of Teachers, Attitudes, and Beliefs

At the end of the twentieth Century, mathematics emphasized how mathematics teachers could improve situations by introducing “interesting mathematics” and analysing such a situation. The emotional and affective domain became a cornerstone for mathematics educators and researchers, mainly since McLeod (1989) worked on beliefs, attitudes, and emotions. In 1994, he published a paper in the *Journal for Research in Mathematics Education*, providing one of the most important reviews on affect and mathematics learning in the last decades (McLeod, 1994). He tracked research in this domain back to the 1960s when researchers such as Schacter and Singer (1962) or H.A. Simon (1967), among others, started to claim that students may develop a negative attitude towards mathematics and their ability to learn mathematics if they experience many situations in which they are unable to solve a problem, or they do not solve the problem according to their expectations (for instance, finding the solution in a short period -like 2 or 3 minutes-). According to McLeod (1992), when students experience negative episodes several times, they develop negative attitudes towards mathematics. He introduced relevant concepts to clarify the field, namely: beliefs (i.e., a problem can be solved quickly or not at all, only geniuses can be creative in mathematics, mathematics is primarily rule-oriented or concept-oriented, mathematics is helpful, but involves mainly memorizing and following rules, etc. -see Schoenfeld, 1985; Fennema & Peterson, 1985; Dossey et al., 1988-), attitudes (affective responses involving positive or negative feelings of moderate-intensity and reasonable stability -see Leder, 1987; Reyes, 1984-), and emotions (i.e., tension, frustration, happiness, etc. -see Bloom & Broder, 1950; Buxton, 1981-). He also highlighted the importance of confidence, self-concept, self-efficacy, and mathematics anxiety to understand how learners feel when learning mathematics.

Philippou and Christou (1998a, b) paid particular attention to the link between history and mathematics teachers’ beliefs and attitudes about mathematics.

Theories of mathematical giftedness entail attitudes to teach mathematics in a school for all to the few: only gifted and “socially useful.” To identify the gifted, more selection and individual differentiation in tests is justified, and the chances of collective learning experiences are ignored or neglected. If a social focus on the “gifted” persists, the majority will not be educated appropriately.

Later, authors such as Markus Hannula led the field, creating the TSG on mathematics and affect in CERME and PME (Hannula, 2006, 2019; Hannula et al., 2004).

In the Iberic American context, the pioneer work on mathematics and affect came from Inés María Gómez Chacón. In 2000 she published her dissertation as a book titled *Matemática Emocional. Los afectos en el aprendizaje matemático*. She worked together with McLeod on mathematics and affect. She provided one of the better classifications of beliefs, attitudes and emotions that is still used largely in the field (Hannula et al., 2005). Since then, many studies have addressed this issue in the Iberic American countries (Blanco et al., 2009, Blanco et al., 2010; Ciro & Torres, 2016; Contreras & Moreno, 2019; García-González et al., 2021; García González &

Pascual Martín, 2017; Gil et al., 2006; Ibarra-González & Eccius-Wellmann, 2018; Perdomo Díaz & Fernández Vizcarra, 2018; etc.). This topic has been raised up also in Iberic American conferences, such as RELME (Farfán & Sosa, 2007; Martínez, 2014; Martínez Padrón et al., 2007), or CIBEM (González, 2009; Martínez Padrón, 2009), among others.

Mathematics still is one of those school subjects that provoke strong feelings of anxiety, aversion, and incompetence. Pupils (and teachers) still dislike school mathematics as a compulsory enterprise without significance. How can a subject raise such solid emotions and block both interest and ability to think mathematically? Why is mathematics so meaningless and challenging for most pupils who consider themselves “mentally handicapped” in mathematics and doomed to failure?

Regarding continuous training and research problems, the tension between peer training programs based on specific reflective practice and school team training that emphasize project work proposals. It has gone from the prevalence of generic studies on professional development and analysis of training models, those based on the epistemic, affective, or socio-cognitive component, to studies that combine reflection on beliefs and professional identity with proposals on social and cultural approaches.

## Critical Issues and Ethnomathematics Studies

Mathematical abstractions and formalizations applied to social reality create formal systems and hierarchies, models, or ways of argumentation that eventually become quasi-natural social rules. By transforming into technology, application, and continuous use, these formalizations turn into representations of “natural” social order and “natural” patterns of social organization, institutions, and regulations - formatting of the society by mathematics has taken place. Mathematics Teacher education must understand the processes of “mathematization” in society and how to prepare teachers to do it. And it must create a critical judgment about it, transparency of the part of mathematics played in social conditions, and enlightenment about the social use of mathematics. It is a way to improve the metacognitive aspect of teaching and know ways to understand modelling as a deep interrelation between social and human aspects of interpreting and changing the world and learning how to introduce debates, analyse the role of language and metaphors, etc.

Critical perspective recognizes still unsolved problems in the research of Teacher Mathematics Education: Is the perception of excellence or high achievement in mathematics different in different cultures, societies, and communities, perhaps depending on class, gender, and ethnicity? Does it respect social awareness and political responsibility? What are various strategies to counteract conflicts, lack of justice, and equal treatment in teaching and learning mathematics in the classroom and the school or broader society? What are the influences of changing social environments on the attitudes towards mathematics and the performance expectations of teachers and parents?

At ICME VI in 1988, for the first time included the social and political dimensions of mathematics education as a legitimate challenge, a matter of worldwide consciousness and recognition.

The recent analysis of Montecino and Valero (2017) states that by deploying a Foucault-inspired discourse analysis on a series of documents produced by these agencies, we argue that nowadays, the cultural thesis about who the mathematics teacher should be are framed in a double bind of the teacher as a policy product and as a sales agent. Narratives about the mathematics teacher are made possible within a dispositive of control, making mathematics education and mathematics teachers the cornerstone for realizing current market-oriented, competitive, and globalized societies.

## **The CIEAEM Contributions to Mathematics Teacher Education**

CIEAEM was born as a space for bridging research and teaching practice that has contributed significantly to improving the teaching and learning of mathematics. Therefore, its very beginning was already marked by a clear orientation towards teacher training, but with an evident emphasis on creating bridges between practitioners and researchers, which, seventy years later, continues to be a unique space.

Throughout the history of this congress, multiple contributions have been made to the professional development of the mathematics teacher. The contribution of the Iberic American community has also been (and it is) relevant. CIEAEM is a privileged space. It offers a unique perspective on mathematics teacher education and the challenges that the teachers of mathematics face in schools. Almost all CIEAEM conferences have included a working group focused on the professional development of teachers. Over the years, the centres of interest have been changing according to the needs of each moment. However, there have always been common elements that have given continuity to the CIEAEM vision of teacher training. The central recurring concern in all editions is: How to promote connections between school mathematics and academic mathematics in teacher training?

In recent times (from 2014 onwards), the Iberic American community has contributed significantly to establishing research lines in teachers' professional development.

In 2014, Javier Díez-Palomar and Gail FitzSimons (FitzSimons & Díez-Palomar, 2014) coordinated a working group on teachers' education at the annual CIEAEM meeting held in Lyon. On this occasion, the central theme was "mathematics and its teaching about other disciplines." Díez-Palomar et al. (2014) discussed the connections of mathematics with other disciplines as a meeting point for preservice teachers' training programs. Drawing on a case study, they addressed questions such as "how can mathematics interact with other disciplines to support the understanding of a multidimensional problem?", highlighting interdisciplinarity as a way

of creating didactic learning units where mathematical objects appear contextualized. These types of proposals encourage the development of the mathematical competence of future teachers.

In 2015, when CIEAEM was held in Aosta, Joaquim Giménez (together with Daniela Ferrarello and Ruhai Floris) coordinated the working group on “teacher education.” The main topic of discussion was the obstacles and difficulties that mathematics teachers must face to carry out their work. Attendees discussed questions such as:

- How is it possible to support teachers to develop relevant knowledge and competencies in digital technologies so that they are effective in their mathematics teaching?
- What are the main obstacles to mathematics teacher development?
- How can the social dimension become a resource for teacher education? What are the programs’ challenges based on social interaction in communities of practice/inquiry?
- How can the affective dimension become a resource for teacher education?

In 2017 the focus was mathematization. The fourth working group focused on “Mathematization as a didactic principle: looking at teachers of mathematics.” The mathematization approach has traditionally been dominated by the contributions of authors influenced by Freudenthal and his Institute in mathematics for pre-and kindergarten, primary and secondary schools. The Iberic American community of the CIEAEM has already made relevant contributions to this research line, such as the piece by Giusti de Souza, Nogueira de Lima, Mendonça Campos and Gerardini (2012).

The most recent contribution of CIEAEM to mathematics teachers’ professional development was found in 2019 when a working group on mathematics teacher education was included again (Panero & Mamede, 2020). The main topic for discussion was the connections and complexity in mathematics teacher education on this opportunity. The following research questions were discussed:

- What kind of mathematics training should teachers have to promote learning with understanding?
- How can teacher training contribute to establishing connections between the various areas of Mathematics?
- How can teacher training contribute to establishing connections between Mathematics and other subjects?
- How to promote connections between school mathematics and academic mathematics in teacher training?
- What competencies do we need to include in professional training programs for mathematics teachers to cope with the increasingly complex world challenges?

The research carried out by Iberic American researchers has incorporated all these topics. Different approaches to teacher education have been used. For example, Pereira Gonçalves and Gomes (2020) discuss the use of the MKT model in the case of numbers and operations. In their work, they reflect on the mathematical

preparation of future teachers (a concern that is recurrent in other Iberic American countries). Font and his colleagues have used the OSA approach to discuss various aspects related to the training of mathematics teachers. They use the didactic suitability criteria (DSC) to identify cognitive, epistemic, emotional, ecological, interactional, and mediational components of mathematical practices and planning and teaching. Other authors have also discussed some of these components. For instance, complexity frameworks have also been introduced to interpret teacher education issues (Giménez, 2020). Bruna (2015), for example, highlights the impact that mathematics teachers' beliefs have on the willingness of students to solve complex math problems. Dilemmas such as "when to correct students: immediately or let them realize their mistake?" are relevant because they affect how students define their identity as problem solvers. According to Bruna (2015), how math teachers act to support (correct) their students affect the feeling of security and confidence students may have when facing word problems. But not only teachers' beliefs have been the subject of the discussion. So has the aspect of emotions. Hummes et al. (2020) claim that the criteria of didactical suitability can be used to analyze and support teachers' didactical choices, allowing us to consider the emotional dimension in connection with the epistemic and cognitive ones.

Other authors, such as Vale et al. (2015), have contributed to teaching tools, such as math trails, designed to create problems. Their reflections highlight the need to transmit to future mathematics teachers' knowledge about the development of effective tasks in teaching mathematics. Their proposal is situated in the tradition of the problem-posing developed by Silver (1997). Similarly, Lobo da Costa et al. (2017) propose "investigative tasks" as tools for teachers to develop teachers technological pedagogical content knowledge. On the other hand, they also offer problem-based learning as a research-based approach to teaching optimization problems (Lopes Galvao et al., 2017).

Diversity has been a recurring theme that brings together an excellent line of research in the Iberian American scope. Giménez et al. (2012) discuss interculturality and citizenship. They provide evidence suggesting that teacher training must prepare future teachers to make connections between mathematics and everyday life, creating tasks based on mathematical principles, but that also integrates students' personal representations, encouraging them to develop a critical sense to make decisions in our society. More recently, Vanegas et al. (2015) reflected on sociocultural contexts as resources to be incorporated in the training of future mathematics teachers. Another different approach within the domain is proposed by Hitt and Rivera (2017) when they use Bourdieu's theory to suggest sociocultural training.

Another of the questions that we have historically asked ourselves in teacher training is, "what is the best way to teach mathematics? Is there a teaching style that is the "best" way to teach mathematics?" Ferrarello et al. (2015) discusses whether a style based on concrete experience (feeling), reflective observation (watching), abstract conceptualization (thinking), or active experimentation (doing) is better. According to his work, the best proposal is perhaps a combination (in a spiral) of all these styles since they help the mathematics teacher manage the complexity of



teaching mathematics better. Other authors, such as Mulat and Berman (2015) draw on the pedagogy of the question (which was initially inspired by Freire), which denotes the profound impact of the Brazilian pedagogue in the mathematics education research that we find in CIEAEM.

The reflection on the best way to teach mathematics leads us to the field of assessment of mathematical knowledge for teaching. Gonçalves and Gomes (2020) adapted a questionnaire and used interviews as research tools. However, they also pointed out methodological aspects that still need to be deepened in mathematics teacher education.

The CIEAEM has also addressed the use of technologies to train preservice teachers. For example, Floris (2015) presents the case of an initial training device to integrate numeric environments in the teaching of mathematics in secondary schools. Drawing on Brousseau's approach (1997), he uses the concept of milieu to integrate a virtual environment in teacher training. In the Iberic American field, this line of research has contributed with studies such as those by Lobo da Costa et al. (2015) and Brito Prado et al. (2015). According to their work, introducing the use of digital technologies as a tool for mathematics teachers requires not only that mathematics teachers know them and know how to use them; they also must be able to reconstruct mathematical concepts in digital environments so that the sense of using these types of resources as tools for training (not as ends in themselves) is not lost.

Interaction (Díez-Palomar et al., 2021) was also raised in CIEAEM as a critical aspect of teacher training. Along with the international scientific community, we find works highlighting the contribution of approaches such as collaborative study groups in the professional development of teachers (Lopes Galvao et al., 2015).

Finally, another relevant contribution of the Iberian American research community has been made in social inclusion. In 2011, Flecha (2011) gave a plenary conference on the teaching of mathematics for social inclusion. He highlighted the transformative role that inclusive mathematics education can have, creating opportunities for those people and groups in a situation of vulnerability. On the other hand, we also find the work of D'Ambrosio (2011), who established an agenda for future teacher training. From his point of view, future mathematics teachers will have to: (a) Promote citizenship and (b) promote creativity.

On the one hand, teachers face the challenge of transmitting past values (which leads to citizenship). They must train students for an uncertain future (which implies creativity). In doing so, D'Ambrosio warns that future teachers must be careful because we neither want to transmit docile citizenship nor promote irresponsible creativity. The key is not justifying the math curriculum we teach simply because it satisfies rigor. D'Ambrosio argues that the mathematics that is needed for the present but above all for the future is that advanced mathematics that promotes the well-being of all people without compromising rigor serves to generate interest motivation. "Education has a responsibility in building up healthy attitudes towards the self, towards society, towards nature." (p.31).

## New Themes, New Perspectives

Where is teacher training going? What are the new topics to work on in the coming years? Suppose we refer to the evolution of the contributions made by the Iberic American community in recent years. In that case, we can conclude, at least, that one obvious fact is that teacher training responds to the needs that arise at each historical moment. This trend will continue in the coming years.

In educational research at the international level (and in mathematics education more specifically), there is a growing interest in approaches of a global nature, which attempt to explain the practice of teaching and learning mathematics as a multidimensional fact with multiple Aspects. Teacher training must provide future mathematics teachers with mathematics content (an old and ever-present debate) but also didactic and pedagogical content (this is also already “old”). But in a world where technologies have transformed educational scenarios (mainly because of the covid-19 pandemic, which has normalized the use of online, hybrid teaching, etc.), teacher training will have to incorporate all these new methodologies, tools, etc., and accommodate them to achieve the goals of excellent and quality mathematics teaching.

In this scenario, surely another critical element will be the assessment. An actual, most controversial debate concerns the quality of teaching and learning mathematics and teacher training research. What are the criteria or methods of evaluating quality in teaching and learning mathematics? Quality management is more effective for institutional management and administration in education than for teaching, learning, and research issues. The effects of recent developments on the structure and content of mathematical curricula can be described by many trends which tend to be similar in many countries. Sustainability for professional development is an unsolved problem (Zehetmeier & Krainer, 2011) and has a lot of influence on implementing innovative teaching (Maass et al., 2019). And we need more research on promoting citizenship in mathematics teaching (Vanegas et al., 2013; Maass et al., 2019).

We also need to enlarge the collaborative experiences of teachers and researchers through inquiry design (Jaworski & Potari, 2021) more about the use of technological tools for teacher education and science-mathematics exchanges.

Finally, everything indicates that teaching based on successful educational actions will become widespread (Flecha, 2014; García-Carrión, Padrós Cuxart, et al., 2020b). Future teachers and in-service teachers will increasingly demand to know the scientific evidence that supports the educational actions that they can implement in their classrooms. Lesson design, teaching planning, quality assessment in teaching and learning mathematics, the effectiveness of methods, teaching strategies, etc., all must be supported by scientific evidence with social and educational impact (García-Carrión, López de Aguilera, et al., 2020a). This will be one of the future challenges, and much research will be needed to confirm that a specific practice is (or is not) successful.

**Acknowledgments** This chapter has been carried out in the context of the projects: PID2019-104964GB-I00 (MICINN) / PGC2018-098603-B-I00/ 2017-SGR-101.

## References

- Alfaro, C., Flores, P., & Valverde, G. (2020). *Conocimiento especializado de profesores de matemática en formación inicial sobre aspectos lógicos y sintácticos de la demostración*. PNA 14:2, 85-117, <https://doi.org/10.30827/pna.v14i2.9363>.
- Almeida, M. V. R., Ribeiro, M., & Fiorentini, D. (2021). *Mathematical specialized knowledge of a mathematics teacher educator for teaching divisibility*. PNA, 15:3, 187-210, <https://doi.org/10.30827/pna.v15i3.15778>.
- Amador, J., Bragelman, J., & Superfine, A. (2021). Prospective teachers' noticing: A literature review of methodological approaches to support and analyze noticing. *Teaching and Teacher Education*, 99, 103256. <https://doi.org/10.1016/j.tate.2020.103256>
- Ball, D. L., Thames, M. H., & Phelps, G. (2008). Content knowledge for teaching: What makes it special. *Journal of Teacher Education*, 59(5), 389-407. <https://doi.org/10.1177/0022487108324>
- Barbé, J., Bosch, M., Espinoza, L., & Gascón, J. (2005). Didactic restrictions on the teacher's practice: The case of limits of functions in Spanish high schools. In C. Laborde, M.-J. Perrin-Glorian, & A. Sierpiska (Eds.), *Beyond the apparent banality of the mathematics classroom* (pp. 235-268). Springer.
- Bernabeu, M., Llinares, S., & Moreno, M. (2021). Levels of sophistication in elementary students' understanding of polygon concept and polygons classes. *Mathematics*, 9(16), 1966.
- Blanco, L., Carrasco, A. C., & Guerrero, E. (2009). El dominio afectivo en la construcción del conocimiento didáctico del contenido sobre resolución de problemas de matemáticas. *Enseñanza de las ciencias*, Extra, 362-365.
- Blanco, L., Carrasco, A. C., Piedehierro, A., Guerrero, E., & del Amo, R. G. (2010). El Dominio afectivo en la Enseñanza/Aprendizaje de las Matemáticas. Una revisión de investigaciones locales. *Campo Abierto Revista de Educación*, 29(1), 13-31.
- Blomeke, S., Gustafsson, J. E., & Shavelson, R. (2015). Beyond dichotomies: Competence viewed as a continuum. *Zeitschrift für Psychologie*, 223(1), 3-13. <https://doi.org/10.1027/2151-2604/a000194>
- Bloom, B. S., & Broder, L. J. (1950). *Problem-solving processes of college students*. University of Chicago Press.
- Borba, M., Askar, P., Engelbrecht, J., Gadanidis, G., Llinares, S., & Sánchez-Aguilar, M. (2016). Blended learning, e-learning and mobile learning in mathematics education. *ZDM-Mathematics Education*, 48(5), 589-610. <https://doi.org/10.1007/s11858-016-0798-4>
- Borko, H., & Potari, D. (2020). *ICMI study 25. Teachers of mathematics working and learning in collaborative groups*. University of Lisbon.
- Bosch, M., et al. (Eds.). (2011). *Un panorama de la TAD. An overview of ATD*. CRM. <http://www.recercat.net/bitstream/handle/2072/200617/Documents10.pdf?sequence=1/41>
- Bosch, M., Gascón, J., & Trigueros, M. (2017). Dialogue between theories interpreted as research praxeologies: The case of APOS and the ATD. *Educational Studies in Mathematics*, 95(1), 39-52. <https://doi.org/10.1007/s10649-016-9734-3>
- Breda, A. (2021). Valoración y rediseño de una unidad sobre proporcionalidad, utilizando la herramienta Idoneidad Didáctica. *Uniciencia*, 35(1), 38-54.
- Breda, A., Pino-Fan, L. R., & Font, V. (2017). Meta didactic-mathematical knowledge of teachers: Criteria for the reflection and assessment on teaching practice. *EURASIA Journal of Mathematics, Science and Technology Education*, 13(6), 1893-1918. <https://doi.org/10.12973/eurasia.2017.01207a>

- Breda, A., Font, V., & Pino-Fan, L. R. (2018). Criterios valorativos y normativos en la Didáctica de las Matemáticas: el caso del constructo idoneidad didáctica. *Bolema*, 32, 255–278.
- Brito Prado, M. E. B., Lobo da Costa, N., & Mendonça Campos, T. M. (2015). Pedagogical use of tablets in mathematics teachers continued education. *Quaderni di Ricerca in Didattica (Mathematics)*, 25(2), 287–293.
- Bronner, A., et al. (Eds.). (2010). *Apports de la théorie anthropologique du didactique. Diffuser les mathématiques (et les autres savoirs) comme outils de connaissance et d'action*. IUFM.
- Brousseau, G. (1997). *Theory of didactical situations in mathematics*. Kluwer Academic Publishers.
- Brown, L., Fernández, C., Helliwell, T., & Llinares, S. (2020). Prospective mathematics teachers as learners in university and school contexts. In L. L. Gwendolyn & O. Chapman (Eds.), *International handbook of mathematics teacher education* (Vol. 3, pp. 343–366). Brill/Sense.
- Bruna, J. (2015). Do teacher's beliefs regarding the pupil's mistake influence willingness of pupils to solve difficult word problems? *Quaderni di Ricerca in Didattica (Mathematics)*, 25(2), 213–217.
- Burgués, C., & Giménez, J. (2007). Formación de maestros en matemáticas: un análisis desde la investigación. *Gaceta de la Real Sociedad Matemática Española*, 10(1), 159–178.
- Buxton, L. (1981). *Do you panic about maths?* Heinemann.
- Cabrera-Baquedano, A., & Pezoa-Reyes, M. (2020, September). Relaciones entre subdominios del PCK: La experiencia de práctica comunitaria. In *IV Congreso iberoamericano sobre conocimiento especializado del profesor de matemáticas* (Vol. 225). Servicio de Publicaciones de la Universidad de Huelva.
- Callejo, M. L., Pérez-Tyteca, P., Moreno, M., & Sánchez-Matamoros, G. (2021). The use of a length and measurement HLT by pre-service kindergarten teachers' to notice children's mathematical thinking. *International Journal of Science and Mathematics Education*, 20, 1–21. <https://doi.org/10.1007/s10763-021-10163-4>
- Carreño, E., & Climent, N. (2009). Polígonos: conocimiento especializado del contenido de estudiantes para profesor de matemáticas. In M. J. González, M. T. González, & J. Murillo (Eds.), *Investigación en Educación Matemática XIII* (pp. 187–196). SEIEM.
- Carrillo, J., Climent, N., Contreras, L. C., & Muñoz-Catalán, M. C. (2013a). Mathematics teacher specialized knowledge. In *Proceedings of eighth ERME congress*.
- Carrillo, J., Climent, N., Contreras, L. C., & Muñoz-Catalán, M. C. (2013b). Determining specialized knowledge for mathematics teaching. In B. Ubuz, C. Haser, & M. A. Mariotti (Eds.), *Proceedings of the VIII congress of the European Society for Research in mathematics education (CERME 8)* (pp. 2985–2994). Middle East Technical University.
- Carrillo, J., Montes, M., Codes, M., Contreras, R. C., & Climent, N. (2019). El conocimiento didáctico del contenido del formador de profesores de matemáticas: su construcción a partir del análisis del conocimiento especializado pretendido en el futuro profesor. In F. Imberón, A. S. Neto, & I. Fortunato (Eds.), *Formação permanente de professores: experiências iberoamericanas* (pp. 324–341). Edições Hipótese.
- Chevallard, Y. (1991). *La transposition didactique – Du savoir savant au savoir enseigné*. La pensée sauvage.
- Chevallard, Y. (2006). Steps towards a new epistemology in mathematics education. In M. Bosch (Ed.), *Proceedings of CERME 4* (pp. 21–30). Fundemi IQS.
- Chevallard, Y. (2007). Readjusting didactics to a changing epistemology. *European Educational Research Journal*, 6(2), 131–134.
- Chevallard, Y., & Sensevy, G. (2014). Anthropological approaches in mathematics education, French perspectives. In *Encyclopedia of mathematics education* (pp. 38–43).
- CIEAEM. (2000). 50 years of CIEAEM. Where we are and where we go. Manifiesto 2000 for the Year of Mathematics. Retrieved from: [https://www.cieaem.org/images/Documents/CIEAEM\\_Manifiesto/CIEAEM\\_Manifiesto.pdf](https://www.cieaem.org/images/Documents/CIEAEM_Manifiesto/CIEAEM_Manifiesto.pdf)
- Ciro, R. D. H., & Torres, M. M. (2016). Lo emocional como articulador de la razonabilidad en la didáctica de la matemática. *INGE@UAN-Tendencias en la ingeniería*, 8(16), 26–34.

- Contreras, J. I. Á., & Moreno, L. C. D. (2019). Emociones en Educación Matemática: una mirada con base en el pensamiento complejo. *Educação & Realidade*, 44, e76639.
- Contreras, L. C., Montes, M., Muñoz-Catalán, M. C., & Joglar, N. (2017). Fundamentos teóricos para conformar un modelo de conocimiento especializado del formador de profesores de matemáticas. In J. Carrillo & L. C. Contreras (Eds.), *Avances, utilidades y retos del modelo MTSK* (pp. 11–25). Actas de las III Jornadas del Seminario de Investigación de Didáctica de la Matemática de la Universidad de Huelva CGSE.
- Corica, A. R., & Otero, M. R. (2009). Analysis of a college mathematics praxeology with respect to the limit of functions and students' productions at the moment of assessment. *Revista latinoamericana de investigación en matemática educativa*, 12(3), 305–331.
- D'Ambrosio, U. (1986). Sociocultural bases for mathematical education. In M. Carss (Ed.), *Proceedings of the fifth international congress on mathematical education* (pp. 1–6). Birkhäuser.
- D'Ambrosio, U. (2011). Mathematicians, mathematics educators and the state of the world. *Quaderni di Ricerca in Didattica (Mathematics)*, 22(2), 25–36.
- Díez-Palomar, J., Gimenez, J., Vanegas, Y., & Font, V. (2014). Connecting mathematics to other disciplines as a meeting point for preservice teachers. *Quaderni di Ricerca in Didattica (Mathematics)*, 24(1), 94–97.
- Díez-Palomar, J., Vanegas, Y., Giménez, J., & Hummes, V. B. (2020). *Discussing 'lesson study' and 'didactical suitability criteria as tools designed for teacher collaboration in mathematics*. ICMI.
- Díez-Palomar, J., Chan, M. C. E., Clarke, D., & Padrós, M. (2021). How does dialogical talk promote student learning during small group work? An exploratory study. *Learning, Culture and Social Interaction*, 30, 100540. <https://doi.org/10.1016/j.lcsi.2021.100540>
- Dindyal, J., Schack, E. O., Choy, B. H., & Sherin, M. G. (2021). Exploring the terrains of mathematics teacher noticing. *ZDM-Mathematics Education*, 53, 1–16. <https://doi.org/10.1007/s11858-021-01249-y>
- Dossey, J. A., Mullis, J. V. S., Lindquist, M. M., & Chambers, D. L. (1988). *The mathematics report card: Trends and achievement based on the 1986 national assessment*. Educational Testing Service.
- Farfán, R., & Sosa, L. (2007). Formación de profesores. Diversas concepciones que afectan el quehacer docente y competencias iniciales de profesores del nivel medio superior. In C. Crespo (Ed.), *Acta Latinoamericana de Matemática Educativa* (Vol. 20, pp. 347–352). Comité Latinoamericano de Matemática Educativa.
- Fennema, E., & Peterson, P. (1985). Autonomous learning behavior: A possible explanation of gender-related differences in mathematics. In L. C. Wilkinson & C. Marrett (Eds.), *Gender influences in classroom interaction* (pp. 17–35). Academic.
- Ferrarello, D., Floris, R., & Gimenez, J. (2015). Teacher education. *Quaderni di Ricerca in Didattica (Mathematics)*, 25(2), 203–204.
- Feucht, F. C., Lunn Brownlee, J., & Schraw, G. (2017). Moving beyond reflection: Reflexivity and epistemic cognition in teaching and teacher education. *Educational Psychologist*, 52(4), 234–241. <https://doi.org/10.1080/00461520.2017.1350180>
- FitzSimons, G., & Díez-Palomar, J. (2014). Mathematics and its teaching in relation to other disciplines. *Quaderni di Ricerca in Didattica (Mathematics)*, 24(1), 65–67.
- Flecha, R. (2011). Mathematics for social inclusion. *Quaderni di Ricerca in Didattica (Mathematics)*, 22(2), 51–55.
- Flecha, R. (2014). *Successful educational actions for inclusion and social cohesion in Europe*. Springer.
- Flores, E., Escudero, D. I., & Carrillo, J. (2013). A theoretical review of specialized content knowledge. In *Proceedings of eighth ERME congress*.
- Floris, R. (2015). Un dispositif de formation initiale pour l'intégration d'environnements numériques dans l'enseignement des mathématiques au secondaire. *Quaderni di Ricerca in Didattica (Mathematics)*, 25(2), 245–249.

- Furinghetti, F. (2000). The history of mathematics as a coupling link between secondary and university teaching. *International Journal of Mathematical Education in Science and Technology*, 31, 43–51. <https://doi.org/10.1080/002073900287372>
- Furinghetti, F., Menghini, M., Arzarello, F., & Giacardi, L. (2008). ICMI renaissance: The emergence of new issues in mathematics education. In M. Menghini, F. Furinghetti, L. Giacardi, & F. Arzarello (Eds.), *The first century of the international commission on mathematical instruction (1908–2008)* (pp. 131–147). Reflecting and shaping the world of mathematics education. Istituto della Enciclopedia Italiana.
- García González, M. D. S., & Pascual Martín, M. I. (2017). De la congoja a la satisfacción: el conocimiento emocional del profesor de matemáticas. *Revista de investigación educativa de la REDIECH*, 8(15), 133–148.
- García Marimón, O., Díez-Palomar, J., Morales Maure, L., & Durán González, R. E. (2021). Evaluación de secuencias de aprendizaje de matemáticas usando la herramienta de los Criterios de Idoneidad Didáctica. *Bolema*, 35, 1047–1072.
- García-Carrión, R., López de Aguilera, G., Padrós, M., & Ramis-Salas, M. (2020a). Implications for social impact of dialogic teaching and learning. *Frontiers in Psychology*, 11, 140. <https://doi.org/10.3389/fpsyg.2020.00140>
- García-Carrión, R., Padrós Cuxart, M., Alvarez, P., & Flecha, A. (2020b). Teacher induction in schools as learning communities: Successful pathways to teachers' professional development in a diverse school serving students living in poverty. *Sustainability*, 12(17), 7146. <https://doi.org/10.3390/su12177146>
- García-González, M. S., Ramírez-Gómez, B., & Navarro-Sandoval, C. (2021). Situaciones que Originan Emociones en Estudiantes de Matemáticas. *Bolema*, 35, 39–62.
- Gellert, U., Barbé, J., & Espinoza, L. (2013). Towards a local integration of theories: Codes and praxeologies in the case of computer-based instruction. *Educational Studies in Mathematics*, 82(2), 303–321. <https://doi.org/10.1007/s10649-012-9427-5>
- Giacomone, B., Godino, J. D., & Beltrán-Pellicer, P. (2018). Developing the prospective mathematics teachers' didactical suitability analysis competence. *Educação e Pesquisa*, 44, e172011.
- Gil, N., Guerrero, E., & Blanco, L. (2006). El dominio afectivo en el aprendizaje de las Matemáticas. *Electronic Journal of Research in Educational Psychology*, 4(1), 47–72.
- Giménez, J. (2020). Complexity with simplicity. *Quaderni di Ricerca in Didattica (Mathematics)*, 7(special issue), 43–54.
- Giménez, J., Vanegas, Y., & Vilella, X. (2012). Intercultural debates and citizenship. Some teacher. Research consequences. *Quaderni di Ricerca in Didattica (Mathematics)*, 22(Supplemento 1), 99–104.
- Giménez, J., Font, V., & Vanegas, Y. (2013). Designing professional tasks for didactical analysis as a research process. Task Design in Mathematics Education. In *Proceedings of ICMI study* (Vol. 22, pp. 581–590).
- Giusti de Souza, H., Nogueira de Lima, R., Mendonça Campos, T. M., & Gerardini, L. (2012). Mathematical modelling and bank loan systems: An experience with a group of youngs and adults. *Quaderni di Ricerca in Didattica (Mathematics)*, 22(Supplemento 1), 104–107.
- Godino, J. D., Batanero, C., & Font, V. (2007). The onto-semiotic approach to research in mathematics education. *ZDM-Mathematics Education*, 39(1), 127–135. <https://doi.org/10.1007/s11858-006-0004-1>
- Godino, J. D., Batanero, C., & Font, V. (2019). The onto-semiotic approach: Implications for the prescriptive character of didactics. *For the Learning of Mathematics*, 39(1), 37–42. <https://www.jstor.org/stable/26742011>
- Gonçalves, C. V. P., & Gomes, A. (2020). Portuguese school teachers' mathematical knowledge for teaching: Questions on numbers and operations. *Quaderni di Ricerca in Didattica (Mathematics)*, 7(special issue), 193–199.
- González, F. (2009). *Problemática del tránsito de la educación secundaria a la educación superior*. Un enfoque multidimensional. Ponencia presentada en VI CIBEM.

- Greene, J. A., Sandoval, W. A., & Bråten, I. (2016) (Eds.). Reflections and future directions. In *Handbook of epistemic cognition*. Routledge.
- Hannula, M. S. (2006). Affect in mathematical thinking and learning: Towards integration of emotion, motivation, and cognition. In J. Maasz & W. Schloeglmann (Eds.), *New mathematics education research and practice* (pp. 209–232). Brill Sense.
- Hannula, M. S. (2019). Young learners' mathematics-related affect: A commentary on concepts, methods, and developmental trends. *Educational Studies in Mathematics*, 100(3), 309–316. <https://doi.org/10.1007/s10649-018-9865-9>
- Hannula, M., Evans, J., Philippou, G., & Zan, R. (2004). Affect in mathematics education—exploring theoretical frameworks. Research forum. In *Proceedings of the 28th conference of the international group for the psychology of mathematics education*. IGPME.
- Hannula, M. S., Gómez Chacón, I. M., Philippou, G., & Schloeglmann, W. (2005). Affect and mathematical thinking. Role of beliefs, emotions and other affective factors. In *Proceedings of the fourth congress of the European Society for Research in Mathematics Education: 18–21 February 2005* (pp. 165–284). European Research in Mathematics Education.
- Hidalgo Moncada, D., Valencia, S. P., Vanegas, Y. M., & Díez-Palomar, J. (2021). Prácticas de docentes universitarios que fomentan la autorregulación del aprendizaje en las matemáticas. *UNIÓN. Revista Iberoamericana de Educación Matemática*, 17, 62.
- Hill, H., Ball, D. L., & Schilling, S. (2008). Unpacking pedagogical content knowledge: Conceptualizing and measuring teachers' topic-specific knowledge of students. *Journal for Research in Mathematics Education*, 39(4), 372–400. <https://doi.org/10.5951/jresmetheduc.39.4.0372>
- Hitt, F., & Rivera, S. Q. (2017). La modelisation mathematique et processus de mathematization dans la formation des enseignants. *Quaderni di Ricerca in Didattica (Mathematics)*, 27(2), 247–252.
- Hummes, V. B., Font, V., & Breda, A. (2019). Combined use of the lesson study and the criteria of didactical suitability for the reflection on the own practice in the training of mathematics teachers. *Acta Scientiae*, 21(1), 64–82.
- Hummes, V., Breda, A., Sanchez, A., & Font, V. (2020). Didactical suitability criteria in videos of lesson study. *Quaderni di Ricerca in Didattica (Mathematics)*, 7(special issue), 257–269.
- Ibarra-González, K. P., & Eccius-Wellmann, C. (2018). Desarrollo y Validación de un Instrumento de Medición de la Afectividad respecto a la Comisión de Errores en Matemáticas. *Bolema*, 32, 673–695.
- Ivars, P., Fernández, C., & Llinares, S. (2019). A learning trajectory as a scaffold for preservice Teachers' noticing of Students' mathematical understanding. *International Journal of Science and Mathematics Education*, 18, 529–548. <https://doi.org/10.1007/s10763-019-09973-4>
- Jaworski, B., & Potari, D. (2021). Implementation of a developmental model of teachers' and didacticians' learning through inquiry: Design, operationalization and outcomes. *ZDM-Mathematics Education*, 53(5), 1073–1084. <https://doi.org/10.1007/s11858-021-01290-x>
- Kraimer, K., Chapman, O., & Zaslavsky, O. (2014). Mathematics teacher educator as learner. In S. Lerman (Ed.), *Encyclopedia of mathematics education* (pp. 431–434). Springer.
- Leder, G. C. (1987). Attitudes towards mathematics. In T. A. Romberg & D. M. Steward (Eds.), *The monitoring of school mathematics* (Vol. 2, pp. 261–277). Wisconsin Center for Education Research.
- Leikin, R., & Zazkis, R. (Eds.). (2010). *Learning through teaching mathematics: Development of teachers' knowledge and expertise in practice*. Springer Science & Business Media.
- Ligozat, F., & Schubauer-Leoni, M.-L. (2009). The joint action theory in didactics. Why do we need it in the case of teaching and learning mathematics. In V. Durand-Guerrier, S. Soury-Lavergne, & F. Arzarello (Eds.), *Proceedings of CERME6, January 28th–February 1st 2009* (pp. 1615–1624). INRP. [www.inrp.fr/editions/cerme6](http://www.inrp.fr/editions/cerme6)
- Llinares, S., Fernández, C., & Sánchez-Matamoros, G. (2016). Changes in how prospective teachers anticipate secondary students' answers. *EURASIA Journal of Mathematics, Science and Technology Education*, 12(8), 2155–2170. <https://doi.org/10.12973/eurasia.2016.1295a>

- Lobo da Costa, N., Brito Prado, M. E. B., & Lopes Galvao, M. E. E. (2015). Mathematics teaching and digital technologies: A challenge to the teacher's everyday school life. *Quaderni di Ricerca in Didattica (Mathematics)*, 25(2), 263–270.
- Lobo da Costa, N., Brito Prado, M. E. B., & Alves Dias, M. (2017). Investigative tasks: Possibilities to develop teachers' technological pedagogical content knowledge. *Quaderni di Ricerca in Didattica (Mathematics)*, 27(2), 235–240.
- Lopes Galvao, M. E. E., Garcia Silva, A. F., & Pietropaolo, R. C. (2015). Collaborative study groups in teacher development: A university school project. *Quaderni di Ricerca in Didattica (Mathematics)*, 25(2), 251–254.
- Lopes Galvao, M. E. E., Lobo da Costa, N., & Brito Prado, B. (2017). Problem-based learning: An investigative approach to teach optimization problems. *Quaderni di Ricerca in Didattica (Mathematics)*, 27(2), 241–246.
- López, L. M. (2021). Noticing: Una revisión bibliográfica sobre los orígenes y perspectivas actuales. *RECHIEM. Revista Chilena de Educación Matemática*, 13(3), 79–92. <https://doi.org/10.46219/rechiem.v13i3.92>
- Maass, K., Cobb, P., Krainer, K., et al. (2019). Different ways to implement innovative teaching approaches at scale. *Educational Studies in Mathematics*, 102, 303–318. <https://doi.org/10.1007/s10649-019-09920-8>
- Martínez, O. (2014). El afecto en el aprendizaje de la Matemática: una mirada desde los docentes paraguayos. In *Actas de la RELME 25* (pp. 1954–1961). CLAME.
- Martínez, M., & Arévalo, E. (2017). Análisis didáctico de prácticas matemáticas de aula utilizando “the knowledge quartet”. *El pensamiento del profesor, sus prácticas y elementos para su formación profesional. Acta Latinoamericana de Matemática Educativa* (pp. 1095–1104). CLAME.
- Martínez Padrón, O. (2009). Sistemas de creencias hacia la matemática observados en docentes, en servicio, que se forman en educación integral. In *Ponencia presentada en el VI CIBEM*.
- Martínez Padrón, O., Villegas, M., & González, F. (2007). Afecto y comprensión en la resolución de problemas. In *Ponencia presentada en RELME 21*. Universidad del Zulia.
- McLeod, D. B. (1989). Beliefs, attitudes, and emotions: New views of affect in mathematics education. In D. B. McLeod & V. M. Adams (Eds.), *Affect and mathematical problem solving* (pp. 245–258). Springer.
- McLeod, D. B. (1992). Research on affect in mathematics education: A reconceptualization. In D. A. Grouws (Ed.), *Handbook of research on mathematics teaching and learning* (pp. 575–596). NCTM.
- McLeod, D. B. (1994). Research on affect and mathematics learning in the JRME: 1970 to the present. *Mathematics Education Research Journal*, 25(6), 637–647. <https://doi.org/10.5951/jresmetheduc.25.6.0637>
- Montecino, A., & Valero, P. (2017). Mathematics teachers as products and agents: To be and not to be. That's the point! In H. Straehler-Pohl, N. Bohlmann, & A. Pais (Eds.), *The disorder of mathematics education*. Springer. [https://doi.org/10.1007/978-3-319-34006-7\\_9](https://doi.org/10.1007/978-3-319-34006-7_9)
- Montes, M. A., Contreras, L. C., & Carrillo, J. (2013). Conocimiento del profesor de matemáticas: Enfoques del MKT y del MTSK. In A. Berciano, G. Gutiérrez, A. Estepa, & N. Climent (Eds.), *Investigación en Educación Matemática XVII* (pp. 403–410). SEIEM.
- Moreno, M., Sánchez-Matamoros, G., Callejo, M. L., Pérez-Tyteca, P., & Llinares, S. (2021). How prospective kindergarten teachers develop their noticing skills: The instrumentation of a learning trajectory. *ZDM-Mathematics Education*, 53, 57–72. <https://doi.org/10.1007/s11858-021-01234-5>
- Mulat, T., & Berman, A. (2015). A pedagogical coaching design focused on the pedagogy of questioning in teaching mathematics. *Quaderni di Ricerca in Didattica (Mathematics)*, 25(2), 333–336.
- Panero, M., & Mamede, E. (2020). Mathematics teacher education/Éducation des enseignants en mathématiques. *Quaderni di Ricerca in Didattica (Mathematics)*, 25(2), 333–336.



- Perdomo Díaz, J., & Fernández Vizcarra, A. (2018). Estudio exploratorio de las emociones en la cotidianidad de las clases de matemáticas. *Revista Electrónica de Investigación Educativa*, 20(4), 133–143.
- Pereira Gonçalves, C. V., & Gomes, A. (2020). Portuguese school teachers' mathematical knowledge for teaching: Questions on numbers and operations. *Quaderni di Ricerca in Didattica (Mathematics)*, 7(special issue), 193–198.
- Philippou, G. N., & Christou, C. (1998a). Beliefs, teacher education and history of mathematics. In A. Olivier & K. Newstead (Eds.), *Proceedings of PME 22* (Vol. 4, pp. 1–9).
- Philippou, G. N., & Christou, C. (1998b). The effect of a preparatory mathematics program in changing prospective teachers' attitudes towards mathematics. *Educational Studies in Mathematics*, 35, 189–206. <https://doi.org/10.1023/A:1003030211453>
- Pinto Sosa, J. E., & González Astudillo, M. T. (2008). El conocimiento didáctico del contenido en el profesor de matemáticas: ¿una cuestión ignorada? *Educación Matemática*, 20(3), 83–100.
- Pintrich, P. R. (2004). A conceptual framework for assessing motivation and self-regulated learning in college students. *Educational Psychology Review*, 16(4), 385–407. <https://doi.org/10.1007/s10648-004-0006-x>
- Quijano, M., & Corica, A. R. (2017). Development of a reference Praxeological model about loci. *Redimat*, 6(2), 192–220. <https://doi.org/10.17583/redimat.2017.2228>
- Radford, L. (2013). Three key concepts of the theory of objectification: Knowledge, knowing, and learning. *Redimat*, 2(1), 7–44. <https://doi.org/10.4471/redimat.2013.19>
- Reyes, L. H. (1984). Affective variables and mathematics education. *The Elementary School Journal*, 84, 558–581. <https://doi.org/10.1086/461384>
- Robutti, O., et al. (2016). ICME international survey on teachers working and learning through collaboration: June 2016. *ZDM-Mathematics Education*, 48, 651–690. <https://doi.org/10.1007/s11858-016-0797-5>
- Rowland, T., Huckstep, P., & Thwaites, A. (2003). The knowledge quartet. In *Proceedings of the British Society for Research into Learning Mathematics* (pp. 97–102).
- Ruiz-Higueras, L., Estepa, A., & Garcia, J. (Eds.). (2007). *Sociedad, Escuela y Matemáticas. Aportaciones de la Teoría Antropológica de lo Didáctico (TAD)*. Universidad de Jaén.
- Schacter, S., & Singer, J. (1962). Cognitive, social and physiological determinants of emotional state. *Psychological Review*, 69, 379–399. <https://doi.org/10.1037/h0046234>
- Schoenfeld, A. H. (1985). *Mathematical problem solving*. Academic.
- Sensevy, G. (2011). Overcoming fragmentation: Towards a joint action theory in didactics. In B. Hudson & M. Meyer (Eds.), *Beyond fragmentation: Didactics, learning and teaching in Europe* (pp. 60–76). Barbara Budrich.
- Sfard, A. (2004). What could be more practical than good research? On mutual relations between research and practice of mathematics education. In M. Niss (Ed.), *Proceedings of the 10th international congress on mathematical education* (pp. 76–91).
- Shulman, L. S. (1986). Those who understand: Knowledge growth in teaching. *Educational Researcher*, 15(2), 4–14. <https://doi.org/10.3102/0013189X015002004>
- Shulman, L. (1987). Knowledge and teaching: Foundations of the new reform. *Harvard Educational Review*, 57(1), 1–23. <https://doi.org/10.17763/haer.57.1.j463w79r56455411>
- Sierra, M. (1995). La formación del profesorado de matemáticas en España: Perspectiva histórica. En L. Blanco y V. Mellado (Eds.), *La formación del profesorado de ciencias y matemáticas en España y Portugal* (pp. 227–242). Universidad de Extremadura.
- Silver, E. A. (1997). Fostering creativity through instruction rich in mathematical problem solving and problem posing. *ZDM-Mathematical Education*, 29(3), 75–80. <https://doi.org/10.1007/s11858-997-0003-x>
- Simon, H. A. (1967). Motivational and emotional controls of cognition. *Psychological Review*, 74, 29–39. <https://doi.org/10.1037/h0024127>
- Solar, H., & Deulofeu, J. (2014). *Tratamiento de la contingencia desde el desarrollo de la competencia de argumentación en el aula de matemáticas*. <http://funes.uniandes.edu.co/5389/>

- Tekin-Sitrava, R., Kaiser, G., & Işksal-Bostan, M. (2021). Development of prospective teachers' noticing skills within initial teacher education. *International Journal of Science and Mathematics Education*, 20, 1611–1634. <https://doi.org/10.1007/s10763-021-10211-z>
- Vale, I., Barbosa, A., & Pimentel, T. (2015). Math trails a rich context for problem-posing: An experience with preservice teachers. *Quaderni di Ricerca in Didattica (Mathematics)*, 25(2), 205–211.
- Vanegas, Y., & Giménez, J. (2021). Prácticas matemáticas democráticas: Análisis de una experiencia escolar. *AIEM*, 19, 71–85. <https://doi.org/10.35763/aiem.v0i19.417>
- Vanegas, Y. M., Díez-Palomar, J., Font, V., & Giménez, J. (2013). Considering extrinsic aspects in the analysis of mathematics teacher-training programs. In A. M. Lindmeier & A. Heinze (Eds.), *Proceedings of the 37th conference of the international group for the psychology of mathematics education* (Vol. 5, p. 188). PME.
- Vanegas, Y., Giménez, J., & Díez-Palomar, J. (2015). Sociocultural contexts as difficult resources to be incorporated by prospective mathematics teachers. *Quaderni di Ricerca in Didattica (Mathematics)*, 25(2), 305–310.
- Vanegas, Y., Prat, M., Giménez, J., & Edó, M. (2021). Tareas profesionales en la formación de maestros de educación infantil. *Acta scientiae*, 23(3), 30–51. <https://doi.org/10.17648/acta.scientiae.6205>
- Venkat, H., & Adler, J. (2020). Pedagogical content knowledge within “mathematical knowledge for teaching”. In S. Lerman (Ed.), *Encyclopedia of mathematics education* (pp. 655–658). Springer.
- Wittgenstein, L. (1953). *Philosophical investigations*. John Wiley & Sons.
- Zamorano, A. (2015). *La práctica de la enseñanza de las matemáticas a través de las situaciones de contingencia*. Unpublished Doctoral dissertation, Universitat Autònoma de Barcelona.
- Zehetmeier, S., & Krainer, K. (2011). Ways of promoting the sustainability of mathematics teachers' professional development. *ZDM-Mathematics Education*, 43(6), 875–887. <https://doi.org/10.1007/s11858-011-0358-x>

# Part IV

## Technology in the Recent History of Mathematics Education

### Introduction

We have experienced and are still experiencing an extraordinary phenomenon in the history of mankind: the technological revolution that is overturning the means of communication between human beings and, as such, is profoundly changing education in general and mathematics education in particular. A lot of questions arise at an ethical, philosophical and sociological levels that we can summarize by the question: *Which kind of contract do we (we as human beings) need to make in order to live in the XXI century?* The historical point of view of the previous revolutions may highlight our reflections. If we consider after Serres (2019) that the three main revolutions in the history of humanity regard the development of information transfer and the relationship between the medium and the message, say the invention of writing, the invention of printing and the invention of digital technology of communication and information, we can look at this moment of contemporary history with care. Indeed, each of the previous periods has brought to human kind a disruption of human societies, moving successively from an oral civilization to a civilization of the book where laws, religions, and education rely on written thought, to a civilization of the diffusion of writing leading to an appropriation of knowledge by individuals which, in each steps, has profoundly changed the knowledge of law, social organization, religions and of course education.

“Every man is pope with a bible in his hand” Luther said, pronouncing a detachment of the law from a hierarchical construction towards a common and debatable law directly from the Book, the Reform.

Everything changed with the Great Schism (1378–1500), a confessional split that divided Europe into two rival denominations and accelerated the rise of national states and churches. (Charle & Verger, 2015, p. 20)<sup>1</sup>

---

<sup>1</sup>« Tout change avec le Grand Schisme (1378–1500). Coupure confessionnelle qui partagea l’Europe en deux obédiences rivales, cette crise accéléra la montée des États et des Églises nationales. » (Translated by us).

In the same way, the current period is changing the relationship between the media and the message, between the signifier and the signified in such a way that one can imagine upheavals as great as those that occurred at the time of the transition from an oral to a written civilization, and at the time of the wide diffusion of the written word.

Education is of course not apart from this historical phenomenon and this part of the book focus on this contemporary history that we are all witnessing. There is a paradigm shift in education that is occurring as well as it occurred in the previous revolutions, from the Socrate's view of an oral transmission of knowledge to Platon's praise of the word fixed (frozen?) by the written word, to the humanist school of the European Renaissance. As an example, in Europe, the period between the end of the fourteenth century to the beginning of the sixteenth century is marked by a significant development of universities. Knowledge is available to all, books are kept in libraries and, in a way, human memory is externalized. The French philosopher Montaigne could then declare: "Better a well-made head than a full one"<sup>2</sup> (Montaigne, 1580/1997); this quotation, a symbol of humanism in education, shows that this externalization of memory gives humans the possibility and the time to think themselves. The parallel with this period of transformations of society as a whole can be drawn with the current period in which this relationship between the media and the message is being disrupted by the appearance of digital technology.

Information and communication technology is part of the great history of computers which are the result of a long evolution of automation of calculation that occurs all along the history of mathematics. Since the calculations made with pebbles (*calculus* in Latin) to the use of algorithms coming from Arabic mathematics, mathematicians have sought to make calculation automatic or to algorithmise mathematics; Pascal and the Pascaline (Pascal, 1645; Champan, 1942) Napier and the table of logarithms (1614), Descartes and analytical geometry allowing geometric problems to be solved by calculation, Leibniz and its calculator (1710), Charles Babbage and Ada Lovelace and the analytical engines (Babbage, 1889/2010) and so on. . . In the period extending over the last 40 years, the appearance of portable calculation means has not left the actors of mathematics education indifferent; this revolution is of course the result of a long history, full of quarrels and controversies that could certainly be compared to the quarrel between the abacists and the algorists in the sixteenth century. The abacists, holding token calculations, were supplanted by the algorists defending pen-and-paper calculations using algorithms of operations on the representation of numbers in a decimal system of position. The woodcut (Fig. 1) attributed to Martin Schongauer and published in Gregor REISCH's *Margarita Philosophica* (1503) shows an allegory of arithmetic deliberately turning to the posited calculation symbolized by Boece and looking away from Pythagoras' abacus. A parallel can be drawn with the advent of personal computers, laptops,

---

<sup>2</sup>Free translation from: "je voudrois aussi qu'on fust soigneux de luy choisir un conducteur, qui eust plustost la teste bien faite, que bien pleine: et qu'on y requisit tous les deux, mais plus les moeurs et l'entendement que la science" (Livre I, chapitre XXV). (I would also like us to be careful to choose a conductor for him, who would have a well-shaped rather than a well-filled head: and that we require both of them, but more morals and understanding than science).

**Fig. 1** The Arithmetic fairy, preferring the use of posed calculations to tokens



calculators, mobile phones. In both cases, one artifact replaces another and tends to favor the portability of calculation. In both cases, the practice of calculation is said to become simpler, more fun, more playful, more satisfying for the calculator, as witnessed by the smile on Boece's face compared to Pythagoras' seriousness (sadness, spite?) in Fig. 1.

To return to more recent events, we can recall the chronology of the development of the Internet and the diffusion of personal computers; the idea of interconnecting computers was theoretically founded by the work in information theory (Shannon, 1948) but practically implemented in the early 1970s with the military network ARPANET. The World Wide Web using hypertext documents in a network was born from research at CERN (*Conseil Européen pour la Recherche Nucléaire*, European Council for Nuclear Research): Sir Tim Berners-Lee wrote:

“HyperText is a way to link and access information of various kinds as a web of nodes in which the user can browse at will. Potentially, HyperText provides a single user-interface to many large classes of stored information such as reports, notes, data-bases, computer documentation and on-line systems help. We propose the implementation of a simple scheme to incorporate several different servers of machine-stored information already available at CERN, including an analysis of the requirements for information access needs by experiments” (Berners-Lee & Caillau, 1990).

In 1993, the WWW software was distributed into the public domain freely and at no cost. In 1995 the World Wide Web Consortium (W3C) was established at MIT (Massachusetts Institute of Technology) complemented with INRIA in France (Institut de Recherche en Informatique et Automatique) but still with the same Open Source License. The development of the World Wide Web followed a significant growth, with a number of active internet users in 2021 of around 4,6 billion, which approximately corresponds to half the global population.

Considering only the history of personal computers, in 1973, the first available micro computer, Micral N was designed in the French INRA (Institut National de la

Recherche Agronomique), and the next year, in 1974 the ALTAIR 8800 was designed in the US by the Micro Instrumentation Telemetry Systems, an American company. It is the starting point of the beginning of Personal Computers (PC), which, under the leadership of IBM, were widely imitated and spread out in the world. This development of personal computers has had a rapid impact on education and despite the appearance and rapid disappearance of tools (think, for example, of cassettes, floppy disks, cd-roms, to name but a few ways of storing data) policies to integrate computers into education have been introduced in most countries, as for example in France “*Plan informatique pour tous*” which was presented to the press on Friday 25 January 1985 by Laurent Fabius, Prime Minister at the time; in Australia: “in the late 1970s the number of microcomputers in Victorian schools grew rapidly.” (Tatnal & Davey, 2004, p. 87); in the UK “British politicians (of all parties) have tended towards enthusiastic espousal of ICT in education” (Haydn & Counsell, 2003, p. 2); in North America (Kozma, 2002; Patrick, 2008); in African countries (Waema, 2005, Seifert et al., 2006); in Asia (Hong & Songan, 2011; Firth & Mellor, 2002; Qiu & Bu, 2013); in Latin American countries (Tinio, 2003; Laia et al., 2011; Valente & Almeida, 2020); in East Europe (Kommers, 2000). . . The impact of ICT uses has been widely studied from the perspective of both teachers and students (Anka, 1980; Dumont, 1988; Sinko & Lehtinen, 1999; Punie et al., 2006; Balanskat et al., 2006; Hernandez, 2017). More particularly, as we focus on mathematics education, the question of the contribution of ICT to mathematics education arises but more generally, the question of the changes that ICT brings into mathematics education is of great interest. Indeed, despite the fact that ICT brings tools for communication and information, it also brings tools that radically change the vision of subjects that are taught in primary and secondary education all over the world, say calculation and geometry. We take here two examples that will be declined and developed in the chapters of this part which are particularly significant of the profound changes in the perception of mathematics subjects.

In the early seventies at MIT, Seymour Papert set out to develop a new and different approach to computers in education (Papert, 1999). He developed a programming language, Logo, to encourage rigorous thinking about mathematics. (Molnar, 1997). Papert wrote that “Logo is a programming language plus a philosophy of education” (p. VIII) and insisted on the fact that through this philosophy, learners would become actors of their own discoveries, which brings us back to Michel de Montaigne’s well-made heads! The foundations of constructionism are then laid.

In the meantime, researchers developed a computer-based environment for the representations of mathematical objects. In France Jean-Marie Laborde created a research project at the university of Grenoble whose aim was to allow visual representations of graph: “Especially in research in combinatorics and graph theory, people are accustomed to supporting their thinking with “small sketches” drawn on a sheet of paper” (Laborde, 2016, p. 53). The idea of “rough book” or “sketchpad” allowing to draw quickly a small drawing supporting the reasoning was born with the first CaBrI (Cahier de Brouillon Informatique) which allowed a direct manipulation of mathematics representations (Fig. 2).

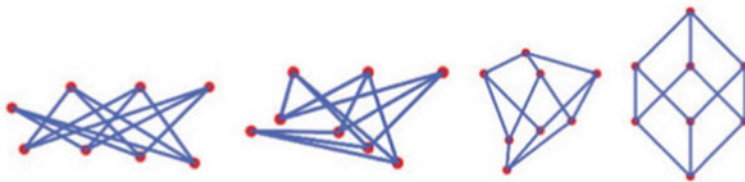


Fig. 2 Transformation of the complete bipartite graph  $K_{4,4}$  into a cube. (Laborde, 2016, p. 54)

The essential property of this geometric manipulation software was to maintain the geometric semantic relationships between the different components of a geometric figure. In the line of Logo, CaBrI was presented as a micro-world with no *a priori* educative contents that have to be developed through the use of the software but based on four fundamental rules of direct manipulation: (1) permanent representation of objects of interest (2) use of physical actions instead of textual commands (3) the result of physical actions should be directly visible (4) these actions should be fast, incremental and reversible.

At approximately the same time, the Geometer Sketchpad came out of a project about visual geometry (Visual Geometry Project) led by Eugene Klotz and Doris Schattschneider at Swarthmore College in the United States of America. Even if the first version didn't include a dragging component but a way of static representation, very quickly, Nicholas Jackiw (designer programmer) incorporated this possibility which has become a fundamental property of all DGS (Digital Geometry Software); from this time a large number of DGS have been developed around the world: C.a.R (Compass and Ruler) developed by Rene Grothmann since 1996,<sup>3</sup> CaRMetal created by Eric Hakenholtz allowing both direct manipulation and programming (Martin, 2010), Cinderella,<sup>4</sup> initially developed by Jürgen Richter-Gebert and Henry Crapo in Germany, the software was rewritten in 1996 and first commercialized in 1998; GeoGebra whose creator Markus Hohewarter started the project in 2001 and took advantage of the properties of direct manipulation, adding possibilities of algebraic representations of the manipulated objects. The development and the success of these software are linked to the dissemination policy but also to the community of users that has been developed all around the world. Thus, information and communication properties are again linked to software development and dissemination.

Another important development of mathematical software is dedicated to the calculations and particularly the transition from numerical analysis software including spreadsheets to computer algebra systems (CAS). This kind of software is also considered as a micro-world in the sense that they do not contain pedagogical content or didactical intentions, but they offer a space to make calculations and manipulation of mathematical formulae.

<sup>3</sup>[https://web.archive.org/web/20170707071912/http://db-maths.nuxit.net/CaRMetal/index\\_en.html](https://web.archive.org/web/20170707071912/http://db-maths.nuxit.net/CaRMetal/index_en.html)

<sup>4</sup><https://cinderella.de/tiki-index.php>

The difference between CAS and numerical calculation is the possibility for CAS to deal with algebraic or infinitesimal calculation coupled with graphical representations. Macsyma, which was born in 1968 at MIT, and REDUCE are considered as the first completed CAS. The first uses of CAS are mainly research, particularly to compute long calculations, as REDUCE which was first dedicated to high energy physics calculations. In the eighties, MuMath, MuSIMP in 1976 and then DERIVE (1988) were developed by David Stoutemyer and Albert Rich at the University of Hawaiï. The portability of Derive as well as its friendly menu-driven interface made it very popular especially in secondary education. The *International DERIVE Journal* created in 1994 after the first DERIVE conference in Plymouth was edited by John Berry and related educational experiences using Derive and more generally CAS:

IDIJ is published to disseminate information about research and practice on the use of DERIVE as a tool for doing and learning mathematics. The journal aims to enhance the use of DERIVE by reporting on research and significant innovations. (Berry, 1994, p. 1).

Subsequently, Derive was implemented in the TI92 calculators (1995) and then in the range of Texas Instruments calculators, TI89, TI Nspire. . . which has made it possible for symbolic calculation to be widely used in mathematics teaching. Other companies such as Casio and Hewlett Packard followed suit and offered formal calculators for use in secondary schools. Calculators, with symbolic calculation or not, are surely an important milestone of the introduction of technology in education. Calculators, which are both inexpensive and portable, first appeared in schools in the 1980s. The debates that their use has provoked clearly show the evolution of calculation teaching and the externalization of procedures that were for a long time a goal to be reached by primary school pupils. A very important literature explored the effects of the introduction of calculators in the mathematics classroom since their introduction (Hembree & Dessart, 1986; Bishop, 1988; Shumway et al., 1981), then graphic calculators (Penglase & Arnold, 1996; Drijvers & Doorman, 1996; Smith, 1996), then CAS calculators (Kutzler, 2000; Ruthven, 1996; Trouche, 2005).

In parallel with this development, the two software packages Maple and Mathematica have been widely developed and used both in research and in teaching, mainly in higher education (Tyncherov et al., 2020; Fissore et al., 2020; Lample & Charton, 2019).

What is important to notice is that the presence of DGS as well as CAS and graphical devices in the educational world has profoundly modified the teaching and learning of mathematics. Geometry is no more static but dynamic and even if the distribution of DGS is not yet widespread, their mere existence and the possibility for teachers to use them changes the perception of the geometric objects manipulated. In the same way, with the spread of graphing calculators and calculators incorporating symbolic calculation, the learning requirements have shifted from description to understanding of phenomena. Take for example the study of functions, which in the 1960s was about drawing a curve, and which now becomes more about describing a mathematical or physical model. As Serres (2019) wrote: “[t]he forces shaping our bodies now come more from the environment we have built than from the given world, more from our culture than from nature” (p. 41).



Therefore, ICT is not only a tool used by human beings but a complete environment that shapes the human behavior and the world of education is no exception to this phenomenon.

In this brief history of mathematical software, I have tried to consider only the micro-worlds without mentioning software built with particular didactical intentions, exercisers, lesson software, etc. This bias is directly linked to the chapters of this part in which the authors describe didactic experiences made possible by the diffusion of this software in education.

Maria Elisabette Brisola Brito Prado, Nielce Meneguelo Lobo da Costa and José Armando Valente present in their chapter the trajectory of digital technology starting from Papert's philosophy of teaching in the context of the Brazilian education system. But more than a contextualized history, they describe, starting from a particular context, the history of geometry software and the impact it has had on the teaching of mathematics through the influences of Papert, D'Ambrósio, Dewey, Freire to the mathematical education research community. The three authors, through their own experience of teaching and research, discuss in the chapter the evolution of teaching and learning mathematics and the appearance of a new learning paradigm. In particular, they point out that the constructionism, born in a computational context, becomes more widely a teaching paradigm in the line of the constructivism but including the importance of student-centering student-centered teaching and the role of developing materials in a rich learning environment. As mentioned above, the fundamental change in the dialectic media-message due to the development of digital technology brings out a new teaching paradigm which changes the relationship to teaching. The concept of computational thinking, already mentioned by Papert, is a consequence of this new approach linking the teaching of mathematics and computer science. The authors of this chapter highlight that in view of the increasing presence of digital technologies in schools, teachers have to develop new knowledge both from a pedagogical point of view, content knowledge and in terms of technological skills.

Marcelo Bairral, as for him, makes a foray into the history of the production of some resources aimed at mathematics teaching and learning showing that the introduction and the wide dissemination of digital technology in the class has led teachers, researchers and mathematics educators to design new teaching environments and new resources. Examples are taken from DGE (Digital Geometry Environments) and particularly with the entry into classrooms of personal devices, mainly mobile devices with touch screens. Tools have always been used to do mathematics as well as to teach them, but what changed when introducing these new digital tools? The concept of a learning environment includes digital technology but enlarges the learners' vision, developing creativity and autonomy. Papert's initial ideas are confirmed and, as already presented above, ICT goes beyond the mere function of a tool to become a learning environment. The author shows the step aside that is made in such environments, not only on the didactic changes but also on the geometric content itself, pointing out the fact that the geometry studied differs on some point from the Euclidean geometry, target of the learning.

Giulia Bini, Monica Panero and Carlotta Soldano consider the evolution of the use of technology in primary and secondary school. The chapter addresses the issue of how teachers deal or have dealt in the past 20, 30 years in integrating technology in the teaching of mathematics. The authors consider technology in its potentialities and show how these potentialities have modified the mathematics teaching approaches. The manipulation of mathematical objects through some of their representations leads to the concept of semiotic potential that is illustrated by the study of Mathematical Internet memes as educational resources. They show how the development of games environments, linked with students centered pedagogy, can enhance knowledge acquisitions. But technology is also a mean to modify the orchestration of debate and mathematics discussions within the class as well as it may change the assessment paradigms, facilitating pupils-pupils teamwork and teacher-pupils interactions through new forms of feedback. Finally, it is a new form of communication facilitated by digital technology and the availability of internet networks that change the way knowledge is transmitted with distance learning and the appearance of online courses. The 2 years of pandemic have shown, if it was needed, the importance of this way of teaching but also the indispensable need for human relations in the transmission of knowledge.

Fernando Hitt, José-Luis Soto and José-Luis Lupiáñez are interested in the history of tools in this contemporary period in direct relation with the history of theoretical frameworks that emerge to accompany and facilitate the understanding of the modification brought about by the introduction of these digital tools in education. Through an observation of three periods, (the sixties and seventies, the end of the twentieth century, and the first years of the twenty-first century) they relate the development of representation and calculation tools to the development of theoretical frameworks in mathematics education pointing out the development of concept in a frame of socio-constructivist theories. They show how the students-centered movement in education and the importance of problem solving and modeling in mathematics both in the discovery of mathematics and their teaching have led the development of new concepts using sociological, anthropological, ergonomics and didactics to cover the understanding of the evolution of teaching and learning.

Through the work carried out by the CIEAEM in recent years, these chapters show that the contemporary history of the introduction of digital technologies in education follows the evolution of human societies. Although critics sometimes accuse education of being out of step with the rapid progress observed in society, these four chapters demonstrate the profound changes that have occurred in the last 40 years, whether from the point of view of content, tools, theoretical thinking or teaching and learning paradigms. However, whatever the promises of the technology, participation everywhere is very unevenly distributed in the world and in a humanistic perspective, sharing experiences and developing education systems remain a priority in the modern world.

“The new technologies have condemned us to be clever” Michel Serres said in a conference given at INRIA in May 2007. Knowledge is immediately available and we are at a distance from knowledge, but it is a question of organizing it, of

imagining, of constructing a new relationship to it based both on what we have lost and on what we are gaining with communication and information technologies.

## References

- Anka, S. S. (1980). *Development, service and application of information and communication technology (ICT) in education*. Journal homepage: [www.ijrpr.com](http://www.ijrpr.com). ISSN, 2582, 7421.
- Babbage, C. (1889/2010). *Calculating engines*. Cambridge University press. Retrieved on June 2022 the 13th from [https://web.archive.org/web/20160304104606/http://monoskop.org/images/4/40/Babbage\\_Charles\\_Calculating\\_Engines.pdf](https://web.archive.org/web/20160304104606/http://monoskop.org/images/4/40/Babbage_Charles_Calculating_Engines.pdf)
- Balanskat, A., Blamire, R., & Kefala, S. (2006). The ICT impact report. *European Schoolnet, 1*, 1–71.
- Berners-Lee, T., & Caillau, R. (1990). *Proposal for a Hyper Text Project, Internal proposal in the CERN*. Retrieved the 16th of June 2022 at [http://cds.cern.ch/record/2639699/files/Proposal\\_Nov-1990.pdf](http://cds.cern.ch/record/2639699/files/Proposal_Nov-1990.pdf)
- Berry, J. (1994). *The international DERIVE Journal* (Vol. 1, p. 1). Ellis Horwood Limited.
- Bishop, A. J. (1988). Mathematics education in its cultural context. *Educational Studies in Mathematics, 19*(2), 179–191.
- Champan, S. (1942). Blaise Pascal (1623-1662). *Nature, 150*, 508–509.
- Charle, C., & Verger, J. (2015). *Histoire des universités, XIIIe-XXIe siècle*. PUF.
- Drijvers, P., & Doorman, M. (1996). The graphics calculator in mathematics education. *The Journal of Mathematical Behavior, 15*(4), 425–440.
- Dumont, B. (1988). New Technologies in Education for new access to information and new hierarchy of communication. In *Children in the information age* (pp. 179–187). Pergamon.
- Firth, L., & Mellor, D. (2002). The importance of national ICT visions for information society in South East Asia. In *ACIS 2002 Proceedings, 86*.
- Fissore, C., Floris, F., Marchisio, M., & Sacchet, M. (2020, November). Maple for distance education in secondary schools during the COVID-19 emergency. In *Maple Conference* (pp. 204–218). Springer.
- Haydn, T., & Counsell, C. (Eds.). (2003). *History, ICT and learning in the secondary school*. RoutledgeFalmer.
- Hembree, R., & Dessart, D. J. (1986). Effects of hand-held calculators in precollege mathematics education: A meta-analysis. *Journal for Research in Mathematics Education, 17*(2), 83–99.
- Hernandez, R. M. (2017). Impact of ICT on education: Challenges and perspectives. *Journal of Educational Psychology-Propositos y Representaciones, 5*(1), 337–347.

- Hong, K. S., & Songan, P. (2011). ICT in the changing landscape of higher education in Southeast Asia. *Australasian Journal of Educational Technology*, 27(8), 1276–1290.
- Kommers, P. (2000). Information and communication technology (ICT) for education: Research and development for the educational integration of technology in Eastern European countries. *Educational Technology Research and Development*, 48, 103–111.
- Kozma, R. B. (2002). *ICT and educational reform in developed and developing countries*. Center for Technology in Learning/SRI International.
- Kutzler, B. (2000). *The algebraic calculator as a pedagogical tool for teaching mathematics*. Paper presented at the T3 world-wide conference, Tokyo, Japan.
- Laborde, J. M. (2016). SOME CaBrI historical background. In M. Bates & A. Usiskin (Eds.), *Digital curricula in school mathematics* (pp. 53–74). Information Age Publishing.
- Laia, M. M. D., Cunha, M. A. V. C. D., Nogueira, A. R. R., & Mazzon, J. A. (2011). Electronic government policies in Brazil: Context, ICT management and outcomes. *Revista de Administração de Empresas*, 51(1), 43–57.
- Lample, G., & Charton, F. (2019). Deep learning for symbolic mathematics. *arXiv preprint arXiv:1912.01412*.
- Leibniz, G. W. (1710). Brevis description Machinæ Arithmeticae, cum figura, dans *Miscellanea Berolinensia ad incrementum scientiarum*, 317–319.
- Martin, Y. (2010). Une géométrie dynamique enrichie. *Express*, 35, 165–272.
- Molnar, A. (1997). Computers in education: A brief history. *The journal*, 24(11), 63–68.
- Montaigne, M. (1580/1997). *Les essais, Bibliothèque de la pléiade*. Gallimard.
- Papert, S. (1999). What is logo? Who needs it In *Logo philosophy and implementation* (pp. 4–16).
- Pascal, B. (1645). *Lettre dédicatoire à Monseigneur le chancelier*, No printing or printer's name, retrieved on June 2022 the 13th from <http://www.bibnum.education.fr/calculinformatique/calcul/la-pascaline-la-machine-qui-releve-du-defaut-de-la-memoire>
- Patrick, S. (2008). ICT in educational policy in the North American region. In *International handbook of information technology in primary and secondary education* (pp. 1109–1117). Springer.
- Penglase, M., & Arnold, S. (1996). The graphics calculator in mathematics education: A critical review of recent research. *Mathematics Education Research Journal*, 8(1), 58–90.
- Punie, Y., Zinnbauer, D., & Cabrera, M. (2006). A review of the impact of ICT on learning. *European Commission, Brussels*, 6(5), 635–650.
- Qiu, J. L., & Bu, W. (2013). China ICT studies: A review of the field, 1989–2012. *The China Review*, 13(2), 123–152.
- Reisch, G. (1503). *Margarita philosophica*. Digitalized retrieved on June 2022 the 13th from <https://daten.digitale-sammlungen.de/0001/bsb00012346/images/index.html>

- Ruthven, K. (1996). Calculators in the mathematics curriculum: The scope of personal computational technology. In *International handbook of mathematics education* (pp. 435–468). Springer.
- Seifert, M., Egert, M., Heerbaart, F., Kolossa, K., Limanski, M., & Mumin, M. (2006). Fostering ICT use in teacher education, in Africa. In *1st Cologne Junior Conference on African Studies (KANT I)*. [http://www.uni-koeln.de/phil-fak/afrikanistik/kant/data/AM1\\_kant1.pdf](http://www.uni-koeln.de/phil-fak/afrikanistik/kant/data/AM1_kant1.pdf)
- Serres, M. (2019). *Hominescence*. Bloomsbury.
- Shannon, C. E. (1948). A mathematical theory of communication. *The Bell System Technical Journal*, 27(3), 379–423.
- Shumway, R. J., Wheatley, G. H., Coburn, T. G., White, A. L., Revs, R. E., & Schoen, H. L. (1981). Initial effect of calculators in elementary school mathematics. *Journal for Research in Mathematics Education*, 12(2), 119–141.
- Sinko, M., & Lehtinen, E. (1999). *The challenges of ICT*. Atena.
- Smith, B. A. (1996). *A meta-analysis of outcomes from the use of calculators in mathematics education*. Texas A&M University-Commerce.
- Tatnal, A., Davey, B. (2004). Streams in the history of computer education in Australia. In *IFIP international conference on the history of computing* (pp. 83–90). Springer.
- Tinio, V. L. (2003). *ICT in Education*. Retrieved from [https://e-learning.tsu.ge/pluginfile.php/183/mod\\_resource/content/0/ict\\_docs/ICT\\_in\\_education.pdf](https://e-learning.tsu.ge/pluginfile.php/183/mod_resource/content/0/ict_docs/ICT_in_education.pdf)
- Trouche, L. (2005). Calculators in mathematics education: A rapid evolution of tools, with differential effects. In *The didactical challenge of symbolic calculators* (pp. 9–39). Springer.
- Tyncherov, K. T., Olenov, A. A., Selivanova, M. V., & Kirichek, K. A. (2020, November). Modeling set theory laws using MAPLE computer algebra system. In *Journal of Physics: Conference Series (1661)* (Vol. 1, p. 012086). IOP Publishing.
- Valente, J. A., & Almeida, M. E. B. (2020). Brazilian technology policies in education: History and lessons learned. *Arquivos Analíticos de Políticas Educativas*, 28(94), n94.
- Waema, M. T. (2005). A brief history of the development of an ICT policy in Kenya. In *At the crossroads: ICT policy making in East Africa* (pp. 25–43).

# Chapter 13

## Tools and Technologies in a Sociocultural Approach of Learning Mathematical Modelling



Fernando Hitt, José-Luis Soto-Munguía, and José-Luis Lupiáñez-Gómez

**Abstract** In this chapter, we are interested in the history of technological tools, in relation with the progress of theoretical frameworks that allow us to explain the phenomena linked to the learning of mathematics. We begin from the second half of last century and finally arrive to the use of tools and technologies to support modelling process in the mathematics classroom. We began with a constructivist theoretical learning approach related to representations that gave support to the technical development of technologies for teaching in the past. We emphasise the cognitive obstacles associated to the use of technologies for the learning of mathematics and the need to approach these obstacles with a new teaching method in a new theoretical sociocultural perspective to learning. We present and exemplify the ACODESA teaching method and the role of the design of chained tasks in a technological environment.

**Keywords** Sociocultural approach of learning · STEM education · Modelling · History of technology

---

F. Hitt (✉)

Département de Mathématiques, Université du Québec à Montréal, Montréal, QC, Canada  
e-mail: [hitt.fernando@uqam.ca](mailto:hitt.fernando@uqam.ca)

J.-L. Soto-Munguía

Departamento de Matemáticas, Universidad de Sonora, Hermosillo, Mexico  
e-mail: [jlsoto@mat.uson.mx](mailto:jlsoto@mat.uson.mx)

J.-L. Lupiáñez-Gómez

Departamento de Didáctica de la Matemática, Universidad de Granada, Granada, Spain  
e-mail: [lupi@ugr.es](mailto:lupi@ugr.es)

## Introduction

CIEAEM<sup>1</sup> members in the 50s influenced the ICMI<sup>2</sup> group by emphasizing some critical issues of mathematics teaching. This paved the way for the creation of institutions dedicated to study how to improve mathematics teaching and learning, thus actually giving rise to the didactics of mathematics as a discipline. Indeed, the third International Congress on Mathematical Education in 1976 (Karlsruhe, Germany) was a key moment in the development of research in mathematics education and the use of technology. To give an example, Freudenthal chaired a panel titled: *what may in the future computers and calculators mean in mathematical education*. Also, in that congress the idea of creating the IGPME<sup>3</sup> emerged.

In the 80s, the abandonment of behaviourist theories was evident, reaffirming constructivism. Theoretical frameworks on the learning of mathematics emerged, emphasizing the role of representations in the construction of concepts (Duval, 1988, 1995; Janvier, 1987). At that time, calculators that only presented a single line on the screen, evolved to calculators with graphing capabilities (Roberts, 2014). A perfect mutual influence between learning theories and teaching with technology.

The technological boom occurred in the 90s. As we said, it was this mutual influence in between the theoretical approach to learning concepts that demanded the articulation among representations in different registers (Duval, 1995; Janvier, 1987) and the multiple screen representation capabilities of the new technological devices (i.e. the Texas Instruments calculators). Unfortunately, the learning difficulties persisted and sociocultural theories on the use of technology emerged (Rabardel, 1995). Guin and Trouche (1999) incorporate the instrumentation and instrumentalization processes, specified by Rabardel, into the learning of mathematics, stressing the cognitive difficulties of conversion among representations.

Another important variable is about what teachers need to know in order to appropriately integrate technology into their teaching, and how this technology could be used to enhance mathematics learning (e.g. TPCK,<sup>4</sup> Mishra & Koehler, 2006). The birth of the STEM<sup>5</sup> program in the 90s, where T stands for technology, accounts for the current problematic of STEM integration (Kelley & Knowles, 2016).

At the beginning of this century, Artigue (2000) points out that for 20 years (1980–2000), technology did not really impact the mathematics classroom, emphasizing some aspects to be developed. Research in mathematics education has then addressed what Artigue pointed out (e.g. Hitt & Kieran, 2009; Hoyles et al., 2004),

---

<sup>1</sup>Commission Internationale pour l'Étude et l'Amélioration de l'Enseignement des Mathématiques (International Commission for Study and Improvement of Teaching Mathematics).

<sup>2</sup>International Commission on Mathematical Instruction.

<sup>3</sup>International Group for the Psychology of Mathematics Education.

<sup>4</sup>Technological Pedagogical Content Knowledge.

<sup>5</sup>Science, Technology, Engineering and Mathematics.

and progress has been made partially finding possible and efficient solutions to the problems raised by Artigue (see for example Aldon, 2015; Aldon et al., 2017).

In early 2020 the entire world was shocked by the advance of the COVID-19 virus. The number of deaths and illnesses in the entire world caused severe decision-making in the daily activities of humans. Distance work was promoted, and particularly in education; These measures led to the closure of schools and universities and promoted the implementation of digital media in distance learning of mathematics.

New problems emerged in the learning of mathematics under this approach of teaching:

- (a) A lag in populations with fewer economic resources (Trouche, 2021),
- (b) A big gap among the teachers' use of technologies to teach online,
- (c) A learning problem because students are not used to this type of environment (many factors are involved).

In relation with the first point (a), to follow the online courses, every family with several children should have several computers and a very good Wi-Fi, this was not the case in all families. The second point (b) is related to the abilities of the teacher to use technological software. Teachers with little experience with technology opted for direct teaching, writing on paper or using a small blackboard and direct filming. Others used PowerPoint and some more experienced teachers were able to integrate most computer packages that allowed them to dynamically teach mathematics. The reaction of the students was immediate: "Online courses, offline brain" (point c), claiming that, in general, the courses were unattractive (Zhang & Liu, 2021).

Regarding the rules that students had to follow, in our case, at the beginning, it was required that students should have their camera opened to see their image, and especially during exams. The problems of unstable networks and slow computers caused that in the courses the students would not be forced to use their camera. Distractions multiplied, students used their cell phone during the courses, or email, or other websites not related to the course and even eating in front of the camera. As an example, an impressive fact provided by the press in Quebec was the announcement about the 40% increase in the use of video games and online casino. Another problem is that psychological symptoms of anxiety began to appear among young people, caused by isolation and lack of communication between them.

A new decade has just begun, and we must learn as much as possible from what happened in these two decades of the present century.

In what follows, we are presenting with more details the evolution of the use of technologies in the teaching of mathematics from the 60s (last century) up to now; also, we are introducing the modelling process in the learning of mathematics and its importance in the new trends of this century in terms of both learning theories and technology functionalities.



## **Modern Mathematics in the 60s, Realistic Mathematics in the 70s, Modelling Process and the Emergence of Software to Support this Trend**

The movement known as “Modern Mathematics” spread from the mid-1950s to the mid-1970s (Kilpatrick, 2012), and its didactic approaches reached the mathematics classrooms of many countries (e.g. France, Italy, USA, Canada among others). The movement privileged the teaching of basic mathematical concepts, algebraic structures and deductive methods (Howson et al., 1981); which left the applications of mathematics practically excluded from the classroom. The opinions of those who warned of the consequences that this exclusion would bring, such as Freudenthal (1968a), Kline (1973) or Pollack (1969), had little weight during that period.

But the first major event to push for the inclusion of applications in mathematics courses was a colloquium that took place in Utrecht in 1967 under the title “*How to Teach Mathematics so as to Be Useful*” and whose proceedings were published a year later (Freudenthal, 1968b). In his opening lecture, Freudenthal said:

The problem is not what kind of mathematics, but how mathematics has to be taught, in its first principles mathematics means mathematizing reality, and for most of its users this is the final aspect of mathematics, too. (Freudenthal, 1968a, p. 7)

Over time, other initiatives related to the Utrecht Colloquium emerged, such as the one undertaken by the National Research Council (1979) in the USA, which struggled to link school mathematics with the real world. An agenda was just beginning to be outlined, which would take hold until “Modern Mathematics” had declined.

The task force that would ultimately be the most important one, for this evolution, met for the first time in 1983 under the name International Community of Teachers of Mathematical Modeling and Applications (ICTMA), and has met every two years thereafter. The group has benefited from at least three events that have taken place in recent decades: (a) The emergence of what is now known as “STEM education” emerged in the 1990s (Chesky & Wolfmeyer, 2015), that promotes integration in the teaching of science, technology, engineering and mathematics, disciplines to which it owes its acronym; (b) The adoption of the Principles and Standards for School Mathematics (NCTM, 2000) in the USA for the mathematics curriculum at levels pre-K-12 and that includes problem solving among its standard processes and (c) The excessive growth of number and diversity of software with the capacity to generate different representations on a computer screen, and which are a valuable tool for mathematical modelling.

When Hohenwarter (2002) created the GeoGebra software, the ICTMA was already a consolidated group, which from its first version was able to combine the ability to perform algebraic calculations, already present in the CAS, with the construction of dynamic graphical representations that generated the DGS and the power of spreadsheets, in such a way that it allowed to produce algebraic representations, two-dimensional graphs and tabular representations, dynamically linked

(Hohenwarter & Jones, 2007). The most recent version also includes a CAS view and allows the construction of three-dimensional dynamic graphs. The software quickly became popular, thanks to its technical advantages and its free use, in such a way that by 2010 it was already available in 50 languages and its website registered that year five million visits from 180 countries (Hohenwarter & Lavicza, 2011).

Practically since its inception, as we will see in Sect. “Mathematical Modelling, Realistic Mathematics and Use of Technology in the Mathematics Classroom” of this chapter, GeoGebra has been adopted as a tool in both mathematics research and teaching in general and has proven to be a valuable tool to promote design and research in mathematical modelling and in projects related to STEM education. Due to the characteristics of the representations GeoGebra produces, it has also opened a new field of research, related to the nature of the cognitive activities of users (Bu & Schoen, 2011).

## **Use of Technology at the End of the Twentieth Century and the Beginning of the 21st**

In this section we describe the digital technological developments that impacted the teaching of mathematics starting from the 1970s.

We will first address what was known as the “programmed teaching” movement, an approach not restricted to the teaching of mathematics, whose theoretical bases came from behaviorism. This was mainly translated into programmed teaching texts and teaching machines, defined by Skinner (1965, p. 6) as “In the broadest sense, teaching machines are simply devices which make it possible to apply technical knowledge of human behavior to the practical field of education”, initially elaborated as mechanical artifacts and later as devices digital. Despite the diversity of criticism that “programmed teaching” received, focusing mainly on the poverty of student learning, the teaching designs were easy to develop and evaluate; This would explain why some characteristics of these designs have been retaken many years later for the organization of courses with technology, as pointed out by McDonald et al. (2005):

Furthermore, at least some surface features of contemporary instructional technology, such as computer-based instruction, interactive video technologies, and online learning bear a resemblance to much of the programmed instructional materials developed 40 years ago. (p. 89)

In parallel, at Stanford University, Patrick Suppes and his collaborators began to develop in the early 1960s a teaching environment that they called “Computer-Assisted Instruction”, later popularized as CAI. This teaching environment was made up of a learning station for the student, equipped with a typewriter and some visual device, a central processor to which the learning stations were connected and that could ask questions to the students and provide feedback on their responses

(Suppes & Macken, 1978). After two years of development and testing, the environment was applied for the first time in an elementary school.

His insistence on the existence of a cognitive hierarchy that could be learned and used to better respond to new situations, led him to conjecture about the existence of an eclectic theory that could arise from behaviorism and cognitive psychology (Suppes, 1975):

I see the convergence of cognitive psychology and the neobehaviorist kind of learning theory I have been sketching in the study of the kinds of internal hierarchies that can be learned and that will prove useful to learn in order to master complex concepts and skills. (p. 281)

In 1966, Papert, Feurzeig, Bobrow and Solomon invented LOGO, the first programming language designed for children. By 1970 they had designed a geometric turtle that could be given instructions in LOGO (Solomon et al., 2020). This turtle was the main piece to create what they called “Microworlds”. The most famous of these microworlds was created with the Geometric Turtle, and it was a learning environment in which children could give orders to a “turtle”, through a reduced number of LOGO commands, and make it trace figures when moving (Hoyles & Noss, 1992).

The works of Papert (1980) and his team rethink the use of computers in teaching, Papert built the theoretical foundation of his didactic approaches based mainly on Piaget’s genetic epistemology, although he included some elements of the theories existing on artificial intelligence:

My perspective is more interventionist. My goals are education, not just understanding. So, in my own thinking I have placed a greater emphasis on two dimensions implicit but not elaborated in Piaget’s own work: an interest in intellectual structures that could develop as opposed to those that actually at present do develop in the child, and the design of learning environments that are resonant with them. (p. 161)

For reasons that are still debated today, the use of Papert’s microworlds began to decline in classrooms, although the idea of learning mathematics by programming a computer was never completely abandoned. Papert’s ideas have been updated with the Scratch programming environment (Resnick et al., 2009; Solomon et al., 2020).

The three contributions described so far responded to the need to incorporate technological tools into global theoretical frameworks that already existed or were being built, but along with these advances other initiatives were developed less concerned with the underlying learning theories. This was the case of the incorporation into the teaching of the BASIC language, created in 1964 by John Kemeny and Thomas Kurtz (Rankin, 2018). Although they never delved into the didactic bases of their project, they were convinced that students could improve their learning by programming a computer.

The use of BASIC in the classroom expanded rapidly after the release of personal computers and became a key element in the training of mathematics teachers, especially since later versions facilitated the design of digital teaching materials by the teachers. But as a tool for teaching mathematics, it is still used, along with other programming languages such as ISETL (Dubinsky & Leron, 1994), Scratch (Resnick et al., 2009), R language (Briz & Serrano, 2018) or Python (Weigend,

2020), always under the assumption that mathematical skills and concepts can be learned by programming a computer.

As the 1980s progressed, the notion of representation in the construction of concepts became more important in mathematics education, giving rise to a congress in 1984 and a publication titled “Problems of Representation in the Teaching and Learning of Mathematics” (Janvier, 1987). In parallel, Duval (1988, 1995) establishes a theoretical framework on representations from a Piagetian point of view, considering that any representation of a mathematical object only partially represents the object. As a consequence, the coordination of the different representations of a mathematical concept or object is absolutely necessary for its construction (Duval, 1995).

An important fact is that technology, together with these theories about representations, had an impact on the reform of calculus in the USA (initial period 1986–1994). The main modification was seen in the presentation of the issues, subject to another principle, which the reformers called “The Rule of Three”, giving rise to the Triple Representation Model curriculum (Schwartz et al., 1990), and which Gleason and Hughes-Hallet (1992) described as follows:

Our project is based on our belief that these three aspects of calculus—graphical, numerical, and analytical should all be emphasized throughout. We call this approach “The Rule of Three” and are working together to design a core curriculum based on this principle. (p. 1)

At the end of the 80s and beginning of the 90s, calculators with a screen appeared, in which numerical, algebraic and graphical representations could be obtained simultaneously and on the other hand, personal computers introduced high resolution monitors and included the “mouse” as an input device. These elements were probably important for incorporating electronic boards (e.g. Excel) into algebra learning (Healy & Sutherland, 1990).

With regard to software related to mathematics education, during this decade existing ones were updated, and new ones emerged. Some of those that today are grouped under the name of Computer Algebra System (CAS), were made available to the public at this time: Matlab (1984, see The MathWorks Inc., 2022), Maple (1985), Mathematica (1988, see Wolfram, 1991) and Derive (1988), to cite just four examples. These software allow the user to graph equations, although their main feature was the ability to perform symbolic calculations.

At the end of that decade, some software with characteristics very different from the CAS saw the light; today they are grouped under the generic name the Dynamic Geometry System (DGS). Two of the best known were the Cabri Géomètre (1988, see Baulac et al., 1990) and the Geometer’s Sketchpad (1989, see Jackiw, 1991). Both designed to produce dynamic geometric constructions, manipulated directly on a computer screen (simulating the constructions with a ruler and compass). But undoubtedly the great technical contribution of the DGS is the “drag” tool, which allows to manipulate the constructions, making the elements that comprise it vary, without the construction losing the properties with which it was originally made.

The increase in the number of computers and calculators in schools and the availability of the aforementioned software considerably increased the interaction

between students and new technologies. This has naturally strengthened those theoretical developments about learning, which argue that the main source of learning mathematics is the activity of students. But these advances also modified the representations of mathematical objects, which were now very different (dynamic representation) from those that a student could produce in his notebook (static representation).

## **Emergency of the Program on Science, Technology, Engineering and Mathematics (STEM)**

The importance and recognition of scientifically training citizens to sustain the social and economic advancement of a country was consolidated in the United States from the Space Race that the Soviet Union began with the launch of Sputnik in 1957. In the 70s, these voices reached the educational field, and several associations, including NSF and NCTM, also highlighted the value of training students in scientific fields (Berube, 2014). Since that time, there have been numerous educational institutions that promote STEM Education as the basis of their curricula, and research has also responded to this movement.

Through a systematic review of almost 800 papers published between 2000 and 2018, Li et al. (2020) have verified several trends in research on STEM Education. One of the most common lines of research in this period is related to history, epistemology, and perspectives about STEM Education. This is justified by the need to conceptually clarify the basis of STEM Education, but Martín-Páez et al. (2019) concluded that there is no consolidated criterion when referring to STEM education in research literature. They found works that (1) only focus on one discipline; (2) produce different combinations without coming to integrate the four disciplines involved in the acronym; and (3) integrate the four disciplines into a single didactic experience. Aguilera et al. (2021b), by analyzing different approaches to the meaning of STEM Education, propose that it “is an interdisciplinary educational approach that promotes students to integrate knowledge and skills from all four disciplines, oriented towards the resolution of problems contextualized in situations with different levels of authenticity” (p. 112).

Research on STEM Education has also led to an in-depth analysis of the role of the disciplines involved in this approach, and in this chapter, we are especially interested in Technology, Mathematics and modelling related to its application in real life. In relation to Technology, Cullen and Guo (2020) point out that “is an integral part of the STEM acronym because it provides the tools and processes by which the other areas advance and do their work” (p. 21). In addition, Ferreira-Gauchía et al., (2012), note that in STEM Education, Technology is not the mere application of scientific knowledge and is aimed at achieving the correct and continuous operation of instruments and systems. On the other hand, Maass et al. (2019) emphasize that modelling is one of the greatest contributions of Mathematics

to the tasks that are part of a STEM Education. In our study, we will show how these assumptions about Technology, Mathematics and modelling are carried out.

The recent revitalization of the STEM constructs in curricular reforms, research and proposals for tasks, and in the development of classroom resources, has also brought with it the reconsideration of the importance of interdisciplinarity, for the necessary integration of the four disciplines involved. Dori et al. (2018) reflect on the importance of teacher training for a STEM education, to try to resolve the persistent conflict between a disciplinary approach and interdisciplinary guidance. To understand levels of integration in STEM Education, it is necessary to reflect on how to establish links between different disciplines.

Following Jantsch (1972), after the isolated consideration of a discipline, *multidisciplinarity* recognizes a grouping of them, but without explicit relationships between them. *Pluridisciplinarity* also considers several disciplines at the same hierarchical level but grouped together in such a way that some relationships between them are improved. *Crossdisciplinarity* implies that one discipline is imposed on others, thus creating a preponderance that does not facilitate coordination. *Interdisciplinarity* generates an axiomatic at a higher hierarchical level, which is common for a group of related disciplines. This approach offers a novel vision through the fusion of concepts, expectations, methods and theoretical frameworks that come from different disciplines. Finally, *transdisciplinarity* requires the coordination of all disciplines based on a widespread axiomatic and an emerging epistemological pattern. In this case, the education provided by a curriculum transcends the boundaries of conventional academic disciplines. Different disciplines enrich each other and promote the development of a similar set of skills. The transdisciplinary approach is said to blur the frontiers between disciplines (Zuberek, 2007).

In their study on the conceptualization and use of STEM education, Martín-Páez et al. (2019), identify research studies that are framed in one of these levels of coordination and cooperation between disciplines. Complementing his analysis, we highlight the studies of Dyrberg and Holmegaard (2019) and Tress et al., (2005) in the case of multidisciplinary; Balsiger (2004) and Kirshner (2002) refer to crossdisciplinarity; Hofstetter (2012) pluridisciplinary; Leikin and Sriraman (2017) and English (2009) the interdisciplinarity, while Khoo et al. (2018) and Nordén (2018) are placed in the context of transdisciplinarity.

Nevertheless, traditional rigid structure presented by most curricula, do not facilitate these ideal levels of integration between disciplines that arise from interdisciplinary and transdisciplinary models. Different disciplines are presented in isolation and rarely make connections between them, in terms of fundamentals, expectations or developments (Martín-Páez et al., 2019). Aguilera et al. (2021a) propose different levels of integration in STEM Education, based on different considerations of an interdisciplinary nature. In any case, these authors consider that adding the terms “integrative” or “integrated” to STEM education is redundant, as the acronym already alludes to disciplinary integration. But, as Akerson and Guo (2020) point out, “all individual disciplines of STEM should be included in ways that are meaningful and showcase the interdependence of the fields” (p. 255).

## From a Constructivist Theoretical Framework to a Sociocultural Approach to Learning of Mathematics in a Technological Environment

As we already said, the decade of the 90s was impressive from the point of view of technological development and its compatibility with constructivist theories related to the construction of concepts through coordination between representations. Considering that every representation of a mathematical object is partial with respect to what it represents, the calculator or computer tried to help solve a critical issue presenting different representations on the screen. At the end of the 90s, the difficulties in the conversion processes among representations demanded to the students in a technological environment were clearer. The detection of visual variables and their relationship with the significant units of the algebraic register (Duval, 1988) were more difficult than expected in a technological setting (Guin & Trouche, 1999). In fact, Artigue (2000) points out the little impact that there had been in the period 1980–2000 on an efficient use of technology in the mathematics classroom.

In the mid-90s, an important work by Rabardel (1995) appeared, taking into account the notion of the zone of proximal development, semiotic mediation and instruments of Vygotsky (Vygotsky, 1932/1962) and activity theory from Leontyev (1978). Rabardel (1995) presented a work on the instrumentalization processes directed to the artifact, and the instrumentation processes relative to the subject. Rabardel explicitly mentions:

The instrumentalization processes are directed towards the artefact: selection, grouping, production and institution of functions, [...] transformation of the artefact, [...]. The instrumentation processes relate to the subject: the emergence and evolution of patterns of use and instrumented action: their constitution, their evolution through accommodation, coordination, and reciprocal assimilation, the assimilation of artefacts new to existing schemes etc. (p. 5)

Thus, from a sociocultural perspective, it is possible to associate concepts well known to the constructivist school, such as the notion of a scheme. In fact, a few years later we have a critique of Vergnaud and Récopé (2000) who affirm that a sociocultural approach without the notions of scheme puts in doubt the operability of sociocultural theory (p. 43).

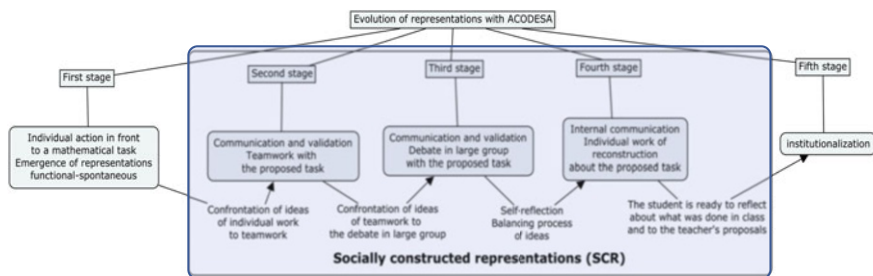
We agree with the affirmation of Vergnaud and Récopé (2000), if one considers only the works of Vygotsky on one side and those of Leontyev on the other. However, to activity theory we can add four elements that can be used in a sociocultural approach to learning:

- (a) A notion of representation closer to an activity theory (Leontyev, 1978), for example, that provided by Davis et al. (Davis et al., 1982): “A representation may be a combination of something written on paper, something existing in the form of physical objects, and a carefully constructed arrangement of ideas in one’s mind” (p. 54).

- (b) A notion of sign linked to communication provided by Voloshinov (1973): “[. . .] The reality of the sign is wholly a matter determined by that communication. After all, the existence of the sign is nothing but the materialization of that communication” (p. 13) and its implementation in a micro-society (Engeström, 1999).
- (c) A notion of objectification processes in the mathematics classroom (Radford, 2021) and taking into account the processes of instrumentation and instrumentalization (Rabardel, 1995).
- (d) A notion of *habitus* (structuring cognitive structure) of Bourdieu (1980): “The conditionings associated with a particular class of existing conditions produce habitus, systems of durable and transposable dispositions, structured structures predisposed to function as structuring structures . . .” (pp. 88–89).

We see that a sociocultural position is possible, considering a definition of representation related to action, a construction of the sign linked to communication and objectification processes together with processes of instrumentation and instrumentalization in computational environments, and a teaching method that considers the classroom as a micro-society to promote a structuring cognitive structure (a *habitus*).

Our proposal for a teaching method under a sociocultural approach in the mathematics classroom takes into consideration ideas from Engeström (1999) to organize communication in the classroom. In this collaborative learning approach, scientific debate (Legrand, 2001) and self-reflection processes (Hitt, 2007; Hitt et al. 2017a, b), designated as ACODESA (this acronym comes from: Apprentissage collaboratif, Débat, Autoréflexion), we can integrate the aforementioned aspects in a sociocultural learning. Under this approach, the notion of spontaneous representation is essential and the problem of making this type of representation evolve requires considering a teaching method in stages such as ACODESA: (a) individual production, (b) teamwork, (c) large group discussion, (d) self-reflection, (e) institutionalization process. According to Hitt and Quiroz (2019), the stages of teamwork, large group discussion and self-reflection are essential for the evolution of spontaneous representations (Fig. 13.1).



**Fig. 13.1** Stages in the co-construction of a representation and its evolution (Hitt & Quiroz, 2019)



## Modelling Process in a Problem-Solving Approach

The research on problem solving, developed at the end of the twentieth century, gave rise to the consideration of mathematical modelling as an important aspect in solving complex problems. In this new paradigm, two main trends are outlined: a European one where mathematical modelling attempts to unify the different didactics (mainly of physics, chemistry, biology and mathematics, e.g. European PRIMAS project) and, as we explained in the preceding section, another STEM also. In this section, we are interested in focusing our attention on mathematical modelling.

Mathematics in context naturally involves a modelling process. The current called “realistic mathematics” (Freudenthal, 1973) involved the investigation of modelling processes. According to Freudenthal (2002), mathematical activity divides it into two parts:

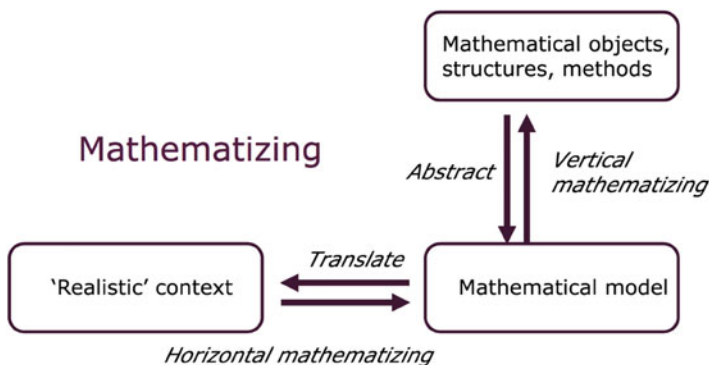
Horizontal mathematisation leads from the world of *life* to the world of *symbols*. In the world of life one lives, acts (and suffers); in the other one symbols are shaped, reshaped, and manipulated, mechanically, comprehendingly, reflectingly; this is vertical mathematisation. (p. 41–42)

Along the same lines, Drijvers (2003) proposes a model (Fig. 13.2).

Gravemeijer (2007), deepening in the processes of mathematization, first distinguishes the “model of” linked to the process of horizontal mathematization, then, continuing in a conceptual deepening, the construction of the “model for” is reached, as a process of vertical mathematization. Doorman et al. (2013) make explicit these processes linked to the design of tasks within the “Algebra Arrows” computing environment:

The study aims at designing and evaluating an ICT-rich learning arrangement. . .

1. which fosters the transition from an input-output conception to a structural conception
2. in which ‘models *for*’ emerge in a natural way from ‘models *of*’, that are rooted in suitable starting points



**Fig. 13.2** Horizontal and vertical mathematization (Drijvers, 2003, p. 54)

3. and which benefits from the opportunities ICT offers, while ensuring that the techniques in the computer tool match with the targeted conceptual development. (p. 431)

## Mathematical Modelling

Problems of mathematical modelling are one of the most valuable resources to promote interdisciplinarity. The strong link that can be established between a particular scientific phenomenon, various mathematical concepts and procedures and a rational use of technology has reinforced its use in the context of a STEM Education. However, there are still important questions that do not have a generally accepted answer in research in Mathematics Education, for example Geiger (2016) claims:

While significant progress has been made in understanding the processes that underpin the successful applications of mathematics in real world contexts, there has been limited research into how to design tasks that are authentic reflections of the role of digital technologies in solving problems situated in the workplace or daily life (Geiger et al., 2010). This is despite the noteworthy progress of research that explores both the themes of mathematical modelling and applications and the use of digital tools to enhance mathematics learning. (p. 285)

Frykholm and Glasson (2005) point out that one of the main difficulties students face when solving real problems is that they fail to understand the context in which these problems are situated. Precisely, promoting the realization of modelling problems in the classroom, favours that student's cultural background plays a relevant role in its own learning (Anhalt et al., 2018).

Technologies can provide a dynamic space for analysis in modelling tasks, which is especially relevant in a STEM Education. For example, using technology, we can recognize the role of sensors that capture actual data from the environment (Muldner & Burleson, 2014) or the use of applications that analyse that data along with mathematical tools that facilitate their study, such as *Tracker*<sup>6</sup> software and dynamic geometry system *GeoGebra*<sup>7</sup> (Lupiáñez, 2018). The use of various applications of mobile phones (Quinn, 2015), spreadsheets and other software (Benacka, 2016; Geiger, 2016), graphing calculators (Hitt, 2011) and even programmable robots (Lopes & Fernandes, 2014) are also resources of interest for the development of modelling problems.

---

<sup>6</sup><https://physlets.org/tracker>

<sup>7</sup><http://geogebra.org>

## Mathematical Modelling, Realistic Mathematics and Use of Technology in the Mathematics Classroom

In accordance with what has been stated about mathematical modelling, our approach to the notions of horizontal mathematization and vertical mathematization, together with the notions of *model of* and *model for*, are integrated into the ACODESA teaching method (see Fig. 13.3) in a technological environment.

Freudenthal (2002) aims at a guided reinvention in the mathematics classroom: [...] guiding reinvention means striking a subtle balance between the freedom of inventing and the force of guiding, between allowing the learner to please himself and asking him to please the teacher. (p. 48) and adding Guilford’s ideas (1967) in this trend, we would have to develop chained tasks that allow a balance between divergent thinking and convergent thinking in the mathematics classroom.

In this mission on the construction of tasks, we were interested in the work of Mason (1996, p. 83) where he considers a spiral cognitive development, in which three stages are important: manipulation, acquisition of meaning (knowing the activity) and articulation. Thus, the manipulation of the objects in play opens a path towards the appropriation of the task to understand it, and the actions to solve it will allow the construction of knowledge and its articulations, reinforcing the learning process. Considering then the idea of Artigue (2002) about the elaboration of chained tasks in a technological context, we elaborate this type of tasks in a work environment in the classroom using the ACODESA method (Aprentissage Collaboratif, Débat and Self-reflection). Thus, the design of chained tasks allows

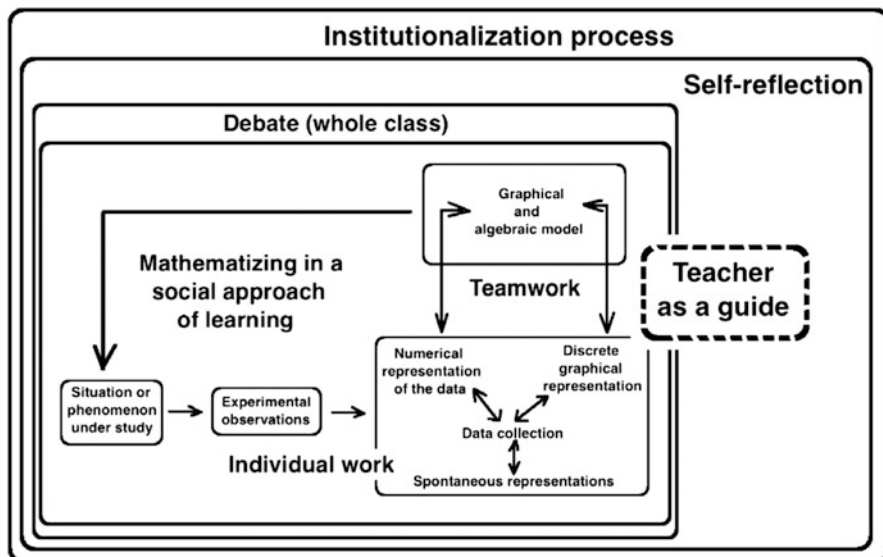


Fig. 13.3 Modelling process in a collaborative learning approach with ACODESA

an evolution of the students' productions, leaving freedom in the production of spontaneous representations, guided by the design of the task and use of technology and bounded by the force of communication (confrontation of arguments) of the other students. Considering that consensus is ephemeral (Thompson, 2002), the self-reflection stage is irrefutable.

Thus, together with the ACODESA method, whose main objective is the evolution of spontaneous representations in the modelling process of complex tasks, it gave rise to the development of chained tasks that allow, on the one hand, freedom of action and reinvention through Freudenthal's proposition, and on the other, to orient students towards institutional representations. We developed this method of teaching in detail in two chapters of the CIEAEM sourcebook: *Mathematics and Technology* (Aldon et al., 2017).

Related to the elaboration of chained tasks, in the first four stages of ACODESA, under a guided reinvention (Freudenthal, 2002; Hitt et al., 2017b), to promote objectivation processes (Radford, 2021) looking at the classroom as a cultural semiotic system (Radford, 1998), the following should be taken into consideration:

- (a) The general objective of the task (or intended mathematical concept),
- (b) How the concept is introduced to understand the task (manipulation stage according to Mason, 1996)
- (c) How the task and communication (teamwork) could influence the actions of the students in the evolution of their spontaneous representations, to be directed towards the expected mathematical concept (acquisition of the meaning according to Mason, 1996),
- (d) How the task, technological support and communication (in a team and in a large group discussion) could influence the actions of articulation of concepts, and construction of action schemes that link work on paper and pencil and technology (construction of schemes of action linked to the processes of instrumentation and instrumentalization according to Rabardel, 1995) and processes of articulation between concepts (articulation stage according to Mason, 1996, construction of the sign according to Voloshinov, 1973).

We follow this trend in the elaboration of several tasks (see Hitt et al., *in press*), related to the concept of generalization in primary school, we are presenting an abstract of this research in the next section.

### ***Example of an Investigation in the Classroom Using ACODESA's Method***

We take an investigation carried out by Quiroz with sixth year elementary school children (Hitt et al., *in press*), contextualized within a chained task called "The pumpkin garden" in Quebec or "The Day of the Dead" in Mexico. This experiment considered realistic mathematics, the design of chained tasks and the use of

ACODESA in a technological environment. The spontaneous representations emerge immediately, and individual work together with teamwork, discussion, process of self-reflection and institutionalization promote evolution of those representations. Evolution of representations is expected in the resolution of chained tasks. In these tasks involving the use of GeoGebra on iPad (6 chained tasks, see Hitt et al., [in press](#)), under the ACODESA teaching method, on one of those (“The Day of the Dead”), we asked for the calculation of: (a) Number of skulls on the road; (b) Number of luminous tiles (green); (c) Number of brown slabs. The global task is presented on several pages as chained tasks: 9 questions to work in a pencil and paper approach; 2 questions to promote a generalization aritmético-algebraic (Hitt et al., [2017c](#)); 3 questions using technology as a tool to support conjectures. After the individual work stage, they are provided with one iPad per team, which allows them to check their guesses in the generalization processes (see Fig. [13.5](#)).

Let us remember that in the instrumentation process Rabardel (1995, p. 5) mentions the emergence of use and instrumented action schemes that is reflected in the students’ production (see Fig. [13.4](#)).

In Fig. [13.4](#), the “skull” represents the number of skulls along the path, “verdes” or “v” (green) represents the number of green slabs. These two variables are used to calculate the brown slabs “m” (brown).

In this experimentation, technology as a tool, permit the children verify their conjectures (see Fig. [13.4](#)) in a process of objectivization in the mathematics classroom seen as a semiotic cultural system (Radford, 1998). In this context about a generalization process, Radford (2010) claims:

These signs may be letters, but not necessarily. Using letters does not amount to doing algebra. The history of mathematics clearly shows that algebra can also be practiced resorting to other semiotic systems. (p. 39)



**Fig. 13.4** Spontaneous representation of teamwork to calculate green slabs and brown slabs (the skull is a spontaneous representation of the variable number of skulls along the way)

We can see (Fig. 13.4) that children in an arithmetico-algebraic thinking are producing spontaneous representations related to a process of generalization in Radford's sense. More details about this experimentation you can see in Hitt et al. (in press).

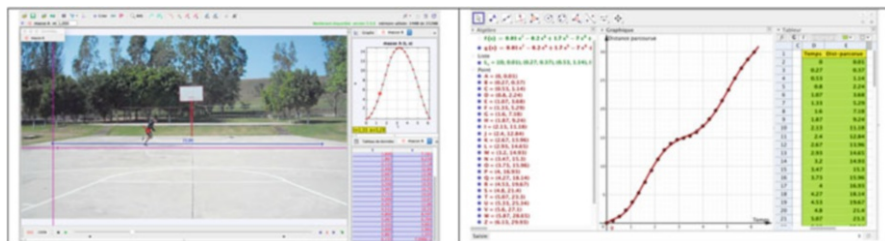
### *Example of Integrating a Cinematic Context, Technology and Mathematics*

The creation of the Avimeca package (University of Rennes) and the Tracker package (COMPADRE, Digital Resources for Physics & astronomy Education) among others, has allowed the analysis of physical phenomena promoting mathematical modelling. These computer packages allow us to collect data when analyzing a video, and with the help of GeoGebra (for example), the treatment of the data obtained provides an enormous wealth to propose mathematical models that allow us to explain the phenomena and predict a future event if necessary. See example of a man crossing a basketball court (Fig. 13.5) and data analysis taking into account time and position, and time and distance travelled.

## Conclusions

In this chapter, we have carried out a brief review on technological tools development linked to the teaching and sociocultural approach of learning mathematical modelling. We started with the first actions carried out by CIEAEM and its influence on the ICMI group.

We have not ignored the issue of distance learning (a consequence of the pandemic, see, e.g., Trouche, 2021; Reimers, 2022) and the learning obstacles associated with this type of teaching. As it was discussed, three main problems emerged in this pandemic period: A lag in populations with fewer economic resources; A big gap among the teachers' use of technologies to teach online;



**Fig. 13.5** Example of a person crossing a basketball court (round trip) using different variables (time-position and time-distance travelled)

Different kinds of learning problems A learning problem because students are not used to follow an online course. On this trend, according to UNESCO (2020), the learning of more than 1.7 billion children and young people from 200 countries was influenced by COVID-19 pandemic. Recent research has also found that when teachers have developed their technological competence, it has been possible to mitigate many of these difficulties. In these cases, as we have highlighted, the rational and efficient use of technology has been and will be essential.

We have shown that, in the technology boom in the 90s, the theoretical frameworks on representations underpinned the use of technology in the classroom in the construction of concepts. It is in the late 90s that cognitive difficulties in the conversion processes between representations linked to the use of technology begin to become clearer. From that moment, other trends of inquiry were developed, such as mathematical modelling, the uses of technology and the role of this technology in modelling tasks.

One more issue was added in the 90s and early this century, which is the importance of the STEM Education, highlighted by the STEM project on the one hand and the European PRIMAS project on the other. In both, mathematical modelling is the central element to put into practice (Maass et al., 2019). The complexity in the process of modelling a mathematical situation promote an emergence of spontaneous representations and this, led us to create a theoretical framework that considers this type of representations, and in a collaborative work, its evolution. Following Freudenthal's ideas of guided reinvention, we present a new approach of chained tasks to use in the mathematical classroom using a specific method of teaching (ACODESA), we exemplified this in a technological environment. Indeed, we agree with Geiger (2016) when he argues that "digital technologies should be considered as essential infrastructure for mathematical problem solving in current and future societies" (p. 288).

From our point of view, in the immediate future, we believe that more research is necessary in mathematical modeling processes that combine a paper and pencil approach together with technology, in a sociocultural approach to teaching (e.g. ACODESA) and learning, considering the main element a guided reinvention through chained tasks.

**Acknowledgments** To the Ministry of Science, Innovation and Universities from Spain for funding project PGC2018-095765-B-I00 and to the European Regional Development Fund for funding project UAL2020-SEJ- D1784.

## References

- Aguilera, D., Lupiáñez, J. L., Vílchez-González, J. M., & Perales-Palacios, F. J. (2021a). In search of a long-awaited consensus on disciplinary integration in STEM education. *Mathematics*, 9, 597. <https://doi.org/10.3390/math9060597>
- Aguilera, D., Lupiáñez, J. L., Vílchez-González, J. M., & Perales-Palacios, F. J. (2021b). In search of a long-awaited consensus for STEM education. A framework proposal. In M. N. Bowman (Ed.), *Topics in science education* (pp. 101–136). Nova Science Publishers.

- Akerson, V. L., & Guo, M. (2020). Reflection on Part III: Critical questions in STEM. In V. L. Akerson & G. A. Buck (Eds.), *Critical questions in STEM education* (pp. 255–256). Springer Nature. [https://doi.org/10.1007/978-3-030-57646-2\\_2](https://doi.org/10.1007/978-3-030-57646-2_2)
- Aldon, G. (2015). Technology and education: Frameworks to think mathematics education in the twenty-first century. In U. Gellert, J. Giménez, C. Hahn, & S. Kafoussi (Eds.), *Educational paths to mathematics a CIEAEM sourcebook* (pp. 365–381). Springer.
- Aldon, G., Hitt, F., Bazzini, L., & Gellert, U. (Eds.). (2017). *Mathematics and technology. A C.I.E. A.E.M. Sourcebook*. Springer.
- Anhalt, C. O., Staats, S., Cortez, R., & Civil, M. (2018). Mathematical modeling and culturally relevant pedagogy. In Y. J. Dori, Z. R. Mevarech, & D. R. Baker (Eds.), *Cognition, metacognition, and culture in STEM education. Teaching, learning and assessment* (pp. 307–330). Springer International Publishing AG.
- Artigue, M. (2000). Instrumentation issues and the integration of computer technologies into secondary mathematics teaching. *Proceedings of the Annual Meeting of GDM*. Potsdam. Retrieved from <http://webdoc.sub.gwdg.de/ebook/e/gdm/2000>, June, 2014.
- Artigue, M. (2002). L'intégration de calculatrices symboliques à l'enseignement secondaire: les leçons de quelques ingénieries didactiques. In D. Guin & L. Trouche (Eds.), *Calculatrices Symboliques transformer un outil en un instrument du travail mathématique: un problème didactique* (pp. 277–349). La Pensée Sauvage.
- Balsiger, P. W. (2004). Supradisciplinary research practices: History, objectives and rationale. *Futures*, 36, 407–421.
- Baulac, Y., Bellemain, F., & Laborde, J. M., designers (1990). *Cabri: The interactive geometry notebook. Cabri Géomètre*. Brooks-Cole.
- Benacka, J. (2016). Calculating ellipse area by the Monte Carlo method and analysing dice poker with excel at high school. *International Journal of Mathematics Education and Science and Technology*, 47(6), 976–986.
- Berube, C. T. (2014). *STEM and the city: A report on STEM education in the great American urban public school system*. Information Age Publishing.
- Bourdieu, P. (1980). *Le sens pratique*. Éditions de Minuit.
- Briz, Á., & Serrano, Á. (2018). Aprendizaje de las matemáticas a través del lenguaje de programación R en Educación Secundaria. *Educación Matemática*, 30(1), 133–162. <https://doi.org/10.24844/em3001.05>
- Bu, L., & Schoen, R. (2011). *Model-Centered Learning. Pathways to Mathematical Understanding Using GeoGebra*. SensePublishers. <https://doi.org/10.1007/978-94-6091-618-2>
- Chesky, N., & Wolfmeyer, M. (2015). *Philosophy of STEM education: A critical investigation*. Palgrave Macmillan. <https://doi.org/10.1057/9781137535467.0006>
- Cullen, T. A., & Guo, M. (2020). The nature of technology. In V. L. Akerson & G. A. Buck (Eds.), *Critical questions in STEM education* (pp. 21–32). Springer Nature. [https://doi.org/10.1007/978-3-030-57646-2\\_2](https://doi.org/10.1007/978-3-030-57646-2_2)
- Davis, R., Young, S., & McLoughlin, P. (1982). *The roles of "understanding" in the learning of mathematics*. Final report of the NSFG. Retrived 15th Feb., 2016 from <http://files.eric.ed.gov/fulltext/ED220279.pdf>
- Derive, 1.0. (1988). *A mathematical assistant program* (2nd & 3rd ed.). Soft Warehouse, Inc.
- Doorman, M., Drijvers, P., Gravemeijer, K., Boon, P., & Reed, H. (2013). Design research in mathematics education: The case of an ICT-rich learning arrangement for the concept of function. In T. Plomp & N. Nieveen (Eds.), *Educational design research – Part B: Illustrative cases* (pp. 425–446). SLO.
- Dori, Y. J., Tal, T., & Heyd-Metzuyanin, E. (2018). SWOT analysis of STEM education in academia: The disciplinary versus cross disciplinary conflict. In O. Hazzan, E. Heyd-Metzuyanin, A. Even-Hazav, T. Tal, & Y. J. Dori (Eds.), *Application of management theories for STEM education. The case of SWOT analysis* (pp. 25–41). Springer.
- Drijvers, P. (2003). *Learning algebra in a computer algebra environment: Design research on the understanding of the concept of parameter*. Dissertation. Utrecht, The Netherlands: CD-B Press.



- Dubinsky, E., & Leron, U. (1994). *Learning abstract algebra with ISETL*. Springer.
- Duval, R. (1988). Graphiques et équations: l'Articulation de deux registres. *Annales de Didactique et de Sciences Cognitives*, 1, 235–253.
- Duval, R. (1995). *Sémiosis et pensée humaine: Registres sémiotiques et apprentissages intellectuels*. Peter Lang.
- Dyrberg, N., & Holmegaard, H. T. (2019). Motivational patterns in STEM education: A self-determination perspective on first year courses. *Research in Science & Technological Education*, 37(1), 90–109.
- Engeström, Y. (1999). Activity theory and individual and social transformation. In Y. Engeström, R. Miettinen, & R.-L. Punamäki (Eds.), *Perspectives on activity theory* (pp. 19–38). Cambridge University Press.
- English, L. D. (2009). Promoting interdisciplinarity through mathematical modelling. *ZDM*, 41(1–2), 161–181.
- Ferreira-Gauchía, C., Vilches, A., & Gil-Pérez, D. (2012). Teachers' conceptions about the nature of technology and the science-technology-society-environment relationships. *Enseñanza de las Ciencias*, 30(2), 197–218. <https://doi.org/10.5565/rev/ec/v30n2.557>
- Freudenthal, H. (1968a). Why to teach mathematics so as to be useful. *Educational Studies in Mathematics*, 1(1/2), 3–8.
- Freudenthal, H. (1968b). Proceedings of the Colloquium "How to Teach Mathematics so as to Be Useful". *Educational Studies in Mathematics*, 1, 1–2.
- Freudenthal, H. (1973). *Mathematics as an educational task*. Springer.
- Freudenthal, H. (2002). *Revisiting mathematics education*. Kluwer.
- Frykholm, J., & Glasson, G. (2005). Connecting science and mathematics instruction: Pedagogical context knowledge for teachers. *School Science and Mathematics*, 105(3), 127–141.
- Geiger, V. (2016). Designing for mathematical applications and modelling tasks in technology rich environments. In A. Leung & A. Baccaglini-Frank (Eds.), *Digital Technologies in Designing Mathematics Education Tasks, mathematics education in the digital era* (pp. 285–301). Springer International Publishing. [https://doi.org/10.1007/978-3-319-43423-0\\_14](https://doi.org/10.1007/978-3-319-43423-0_14)
- Geiger, V., Faragher, R., & Goos, M. (2010). CAS-enabled technologies as 'agents provocateurs' in teaching and learning mathematical modelling in secondary school classrooms. *Mathematics Education Research Journal*, 22(2), 48–68.
- Gleason, A. M., & Hughes-Hallett, D. (1992). The calculus consortium based at Harvard University. *Focus on calculus: A newsletter for the calculus consortium at Harvard University*, 1, 1–3. Retrieved from <http://personal.denison.edu/~whiteda/files/Teaching/Pedagogy/Theory%20of%20Pedagogy/Use%20to%20Summarize%20Harvard%20Calc.pdf>, Oct, 2021
- Gravemeijer, K. (2007). Emergent modelling as a precursor to mathematical modelling. In W. Blum, P. Galbraith, H. Henn, & M. Niss (Eds.), *Modelling and applications in mathematics education* (pp. 137–144). Springer.
- Guilford, J. P. (1967). *The nature of human intelligence*. McGraw-Hill.
- Guin, D., & Trouche, L. (1999). The complex process of converting tools into mathematical instruments: The case of calculators. *International Journal of Computers for Mathematical Learning*, 3, 195–227.
- Healy, L., & Sutherland, R. (1990). The use of spreadsheets within the mathematics classroom. *International Journal of Mathematics Education in Science and Technology*, 21(6), 847–862.
- Hitt, F. (2007). Utilisation de calculatrices symboliques dans le cadre d'une méthode d'apprentissage collaboratif, de débat scientifique et d'auto-réflexion. In M. Baron, D. Guin, & L. Trouche (Eds.), *Environnements informatisés et ressources numériques pour l'apprentissage. Conception et usages, regards croisés* (pp. 65–88). Hermès.
- Hitt, F. (2011). Construction of mathematical knowledge using graphic calculators (CAS) in the mathematics classroom. *International Journal of Mathematics Education and Science and Technology*, 42(6), 723–735.

- Hitt, F., & Kieran, C. (2009). Constructing knowledge via a peer interaction in a CAS environment with tasks designed from a task-technique-theory perspective. *International Journal of Computers for Mathematical Learning*, 14, 121–152.
- Hitt, F., & Quiroz, S. (2019). Formation et évolution des représentations fonctionnelles-spontanées à travers un apprentissage socioculturel. *Annales de didactique et de Sciences Cognitives*, 24, 75–106.
- Hitt, F., Cortés, C., & Saboya, M. (2017a). Integrating arithmetic and algebra in a collaborative learning and computational environment using ACODESA. In G. Aldon, F. Hitt, L. Bazzini, & U. Gellert (Eds.), *Mathematics and technology. A C.I.E.A.E.M. Sourcebook* (pp. 285–311). Springer.
- Hitt, F., Saboya, M., & Cortés, C. (2017b). Task design in a paper and pencil and technological environment to promote inclusive learning: An example with polygonal numbers. In G. Aldon, F. Hitt, L. Bazzini, & U. Gellert (Eds.), *Mathematics and technology. A C.I.E.A.E.M. Sourcebook* (pp. 57–74). Springer.
- Hitt, F., Saboya, M., & Cortés, C. (2017c). Rupture or continuity: The arithmetico-algebraic thinking as an alternative in a modelling process in a paper and pencil and technology environment. *Educational Studies in Mathematics*, 94(1), 97–116.
- Hitt, F., Quiroz, S., Saboya, M., & Lupiáñez, J-L. (in press). Construction sociale de processus de généralisation arithmético-algébriques dans une approche par compétences à l'école québécoise et mexicaine. *Revue Educación Matemática*.
- Hofstetter, R. (2012). Educational sciences: Evolutions of a Pluridisciplinary discipline at the crossroads of other disciplinary and professional fields (20th century). *British Journal of Educational Studies*, 60(4), 317–335.
- Hohenwarter, M. (2002). *GeoGebra – Ein Software system für dynamische Geometrie und Algebra der Ebene*. Master thesis, University of Salzburg.
- Hohenwarter, M., & Jones, K. (2007). Ways of linking geometry and algebra: The case of GeoGebra. *Proceedings of the British Society for Research into Learning Mathematics*, 27(3), 126–131. : BSRLM.
- Hohenwarter, M., & Lavicza, Z. (2011). The strength of the community: How GeoGebra can inspire technology integration in mathematics. In L. Bu & R. Schoen (Eds.), *Model-centered learning. Pathways to mathematical understanding using GeoGebra* (pp. 7–12). Sense Publishers.
- Howson, G., Keitel, K., & Kilpatrick, J. (1981). *Curriculum development in mathematics*. Cambridge University Press.
- Hoyle, C., & Noss, R. (1992). A pedagogy for mathematical microworlds. *Educational Studies in Mathematics*, 23, 31–57.
- Hoyle, C., Noss, R., & Kent, P. (2004). On the integration of digital technologies into mathematics classrooms. *International Journal of Computers for Mathematical Learning*, 9, 309–326.
- ICMI. (1976). *Bulletin of the international commission on mathematical instruction*. No. 8, December 1976. Retrieved from [https://www.math.uni-bielefeld.de/icmi/bulletin/ICMI\\_08\\_12\\_1976.pdf](https://www.math.uni-bielefeld.de/icmi/bulletin/ICMI_08_12_1976.pdf), Nov, 2020.
- Jackiw, N. (1991). *The geometer's sketchpad* [computer program]. Key Curriculum Press.
- Jantsch, E. (1972). Inter- and transdisciplinary university: A systems approach to education and innovation. *Higher Education*, 1(1), 7–37.
- Janvier, C. (Ed.). (1987). *Problems of representation in the teaching and learning of mathematics*. Lawrence Erlbaum Associates.
- Kelley T. R., & Knowles J. G. (2016). A conceptual framework for integrated STEM education. *International Journal of STEM Education*, 3, 1-11. Open Access: <https://doi.org/10.1186/s40594-016-0046-z>.
- Khoo, S.-M., Haapakoski, J., Hellstén, M., & Malone, J. (2018). Moving from interdisciplinary research to transdisciplinary educational ethics: Bridging epistemological differences in researching higher education internationalization(s). *European Educational Research Journal*, 18(2), 181–199.

- Kilpatrick, J. (2012). The new math as an international phenomenon. *ZDM Mathematics Education*, 44, 563–571. <https://doi.org/10.1007/s11858-012-0393-2>
- Kirshner, D. (2002). Untangling teachers' diverse aspirations for student learning: A crossdisciplinary strategy for relating psychological theory to pedagogical practice. *Journal for Research in Mathematics Education*, 33(1), 46–58.
- Kline, M. (1973). *Why Johnny Can't add: The failure of the new math*. St. Martin's Press.
- Legrand, M. (2001). Scientific debate in mathematics courses. In D. Holton (Ed.), *The teaching and learning of mathematics at university level: An ICMI Study* (pp. 127–135). Kluwer Academic Publishers.
- Leikin, R., & Sriraman, B. (2017). *Creativity and giftedness. Interdisciplinary perspectives from mathematics and beyond*. Springer International Publishing.
- Leontyev, A. (1978). *Activity, consciousness, and personality*. Prentice Hall.
- Li, Y., Wang, K., Xiao, F., & Froyd, J. E. (2020). Research and trends in STEAM education: A systematic review of journal publications. *International Journal of STEM Education*, 7, 11.
- Lopes, P. C., & Fernandes, E. (2014). Literacy, reasoning and statistical thinking with robots. *Quadrante*, 23(2), 69–93.
- Lupiáñez, J. L. (2018). Resolución de problemas y tecnología en el desarrollo de la competencia STEM. In P. Flores, J. L. Lupiáñez, & I. Segovia (Eds.), *Enseñar matemáticas. Un homenaje a los profesores Francisco Fernández y Francisco Ruiz* (pp. 203–214). Atrio.
- Maass, K., Geiger, V., Romero-Ariza, M., & Goos, M. (2019). The role of mathematics in interdisciplinary STEM education. *ZDM Mathematics Education*, 51(6), 869–884. <https://doi.org/10.1007/s11858-019-01100-5>
- Maple. (1985). Maplesoft, a division of Waterloo Maple Inc., Waterloo, Ontario.
- Martín-Páez, T., Aguilera, D., Perales-Palacios, F. J., & Vílchez-González, J. M. (2019). What are we talking about when we talk about STEM education? A review of literature. *Science Education*, 103, 799–822. <https://doi.org/10.1002/sce.21522>
- Mason, J. (1996). Expressing generality and roots of algebra. In N. Bernarx, C. Kieran, & L. Lee (Eds.), *Approaches to algebra: Perspectives for research and teaching* (pp. 65–86). Kluwer Academic Publishers.
- McDonald, J. K., Yanchar, S. C., & Osguthorpe, R. T. (2005). Learning from programmed instruction: Examining implications for modern instructional technology. *Educational Technology Research and Development*, 53, 84–98. <https://doi.org/10.1007/BF02504867>
- Mishra, P., & Koehler, M. (2006). Technological pedagogical content knowledge: A framework for teacher knowledge. *Teachers College Record*, 108(6), 1017–1054.
- Muldner, K., & Burtleson, W. (2014). Utilizing sensor data to model students' creativity in a digital environment. *Computers in Human Behavior*, 42(C), 127–137.
- National Research Council. (1979). *The Role of Applications in the Undergraduate Mathematics Curriculum*. The National Academies Press. <https://doi.org/10.17226/19835>
- NCTM. (2000). *Principles and standards for school mathematics*. NCTM.
- Nordén, B. (2018). Transdisciplinary teaching for sustainable development in a WholeSchool project. *Environmental Education Research*, 24(5), 663–677.
- Papert, S. (1980). *Mindstorms: Children, computers and powerful ideas*. Basic Books.
- Pollack, H. (1969). How can we teach applications of mathematics? *Educational Studies in Mathematics*, 2(2/3), 393–404.
- Quinn, A. (2015). Using apps to visualize graph theory. *The Mathematics Teacher*, 108(8), 626–631.
- Rabardel, P. (1995). *Les hommes et les technologies, approche cognitive des instruments Contemporains*. Armand Colin. HAL: hal-01017462, Consulted 5 April 2016.
- Radford, L. (1998). *On culture and mind, a post-Vygotskian semiotic perspective, with an example from Greek mathematical thought*. Paper presented at the 23rd annual meeting of the semiotic society of America, Victoria College, University of Toronto, October 15–18, 1998. Retrieved from <http://www.laurentian.ca/educ/lradford/>

- Radford, L. (2010). Layers of generality and types of generalization in pattern activities. *PNA*, 4(2), 37–62.
- Radford, L. (2021). *The theory of objectification. A Vygotskian perspective on knowing and becoming in mathematics teaching and learning*. Brill.
- Rankin, J. (2018). *A people's history of computing in the United States*. Harvard University Press.
- Reimers, F. M. (Ed.). (2022). *Primary and secondary education during COVID-19*. Springer.
- Resnick, M., Maloney, J., Monroy-Hernández, A., Rusk, N., Eastmond, E., Brennan, K., Millner, A., Rosenbaum, E., Silver, J., Silverman, B., & Kafai, Y. (2009). Scratch: Programming for all. *Communications of the ACM*, 52(11), 60–67.
- Roberts, D. L. (2014). History of tools and technologie in mathematics. In A. Karp & G. Schubring (Eds.), *Handbook on the history of mathematics education* (pp. 565–578). Springer.
- Schwartz, B., Dreyfus, T., & Brukheimer, M. (1990). A model of the function concept in a three-fold representation. *Computers Education*, 14(3), 249–262.
- Skinner, B. (1965). Reflections on a decade of teaching machines. In R. Glaser (Ed.), *Teaching machines and programed learning. II, data and directions* (pp. 5–20). National Education Association of the United States.
- Solomon, C., Harvey, B., Kahn, K., Lieberman, H., Miller, M., Minsky, M., Papert, A., & Silverman, B. (2020). *History of Logo*. Proceedings of the ACM Programming Languages 4, HOPL, Article 79.
- Suppes, P. (1975). From behaviorism to neobehaviorism. *Theory and Decision*, 6, 269–285.
- Suppes, P., & Macken, E. (1978). The historical path from research and development to operational use of CAI. *Educational Technology*, 18(4), 9–12.
- The MathWorks Inc. (2022). *MATLAB version: 9.13.0 (R2022b)*. The MathWorks Inc. <https://www.mathworks.com>
- Thompson, P. (2002). Some remarks on conventions and representations. In F. Hitt (Ed.), *Mathematics visualisation and representations* (pp. 199–206). Psychology of Mathematics Education North American Chapter and Cinvestav-IPN.
- Tress, B., Tress, G., & Fry, G. (2005). Defining concepts and the process of knowledge production in integrative research. In B. Tress, G. Tress, G. Fry, & P. Opdam (Eds.), *From landscape research to landscape planning: Aspects of integration, education, and application* (pp. 13–26). Springer.
- Trouche, L. (2021). Covid-19: les défis en termes de ressources et collaboration des enseignants. *Le Bulletin de l'APMEP*, No. 539, 3–10.
- UNESCO. (2020). *Policy brief: Education during COVID-19 and beyond*. United Nations. [https://www.un.org/development/desa/dspd/wp-content/uploads/sites/22/2020/08/sg\\_policy\\_brief\\_covid-19\\_and\\_education\\_august\\_2020.pdf](https://www.un.org/development/desa/dspd/wp-content/uploads/sites/22/2020/08/sg_policy_brief_covid-19_and_education_august_2020.pdf)
- Vergnaud, G., & Récopé, M. (2000). De Revault d'Allonnes à une théorie du schème aujourd'hui. *Psychologie Française*, 45(1), 35–50.
- Voloshinov, V. N. (1973). *Marxism and the phylosophy of langage*. (L. Matejka, I. R. Titunik, Trans.). Harvard University Press.
- Vygotsky, L. (1932/1962). *Thought and language*. MIT Press.
- Weigend, M. (2020). Programming languages for secondary schools, python. In A. Tatnall (Ed.), *Encyclopedia of education and information technologies* (pp. 1370–1378). Springer.
- Wolfram, S. (1991). *Mathematica: A system for doing mathematics by computer* (2nd Edn). Addison-Wesley.
- Zhang, Y., & Liu, B. (2021). Psychological distress among chinese college students during the COVID-19 pandemic: Does attitude toward online courses matter? *Frontiers in Psychology*. Published online 2021 May 28. <https://doi.org/10.3389/fpsyg.2021.665525>
- Zuberek, M. (2007). Multidisciplinarity – the grand challenge and the future of academia. In E. Kovács, P. Olajos, & T. Tómacs (Eds.), *Proceedings of the 7th international conference on applied informatics* (Vol. 2, pp. 81–91). Eszterházy Károly College.

# Chapter 14

## Technology in Primary and Secondary School to Teach and Learn Mathematics in the Last Decades



Giulia Bini, Monica Panero, and Carlotta Soldano

**Abstract** There is no doubt that the introduction of digital technology in primary and secondary school has radically changed the way of teaching and learning. Specifically, considerable changes have occurred in the field of mathematics education. The aim of this chapter is to highlight such an evolution taking into account different and distinct aspects and points of view which are proper to mathematics teaching and learning. After all, the integration of digital tools into the world of education was unavoidable and necessary, and both teachers and students have been developing new knowledge and skills to face an evolving digitalized society and to become critical thinkers and informed citizens. In the last 30 years, teachers and students have experimented with new ways of manipulating, visualising, representing and treating mathematical objects, new approaches to pose, face and solve mathematical problems, new processes for designing and playing mathematical games, new strategies to assess mathematical skills, and nowadays also new forms of distance teaching and learning. On their side, researchers in mathematics education have detected and studied these new skills, approaches, processes, and strategies in order to provide teachers with the necessary tools and support to exploit effectively the functionalities offered by the technology. The focus of this chapter is on the integration of technology into mathematics teaching, the main issues that have been faced in the last 30 years and the challenges that are still to be faced. A survey

---

G. Bini

Dipartimento di Matematica, Università degli Studi di Milano, Milan, Italy

e-mail: [giuliagiovanna.bini@unimi.it](mailto:giuliagiovanna.bini@unimi.it)

M. Panero (✉)

Dipartimento formazione e apprendimento, Scuola universitaria professionale della Svizzera italiana, Locarno, Switzerland

e-mail: [monica.panero@supsi.ch](mailto:monica.panero@supsi.ch)

C. Soldano

Dipartimento di Filosofia e di Scienze dell'Educazione, Università degli Studi di Torino, Turin, Italy

e-mail: [carlotta.soldano@unito.it](mailto:carlotta.soldano@unito.it)

of the literature helps outlining the existing landscape, and the current issues are highlighted and illustrated through the description and analysis of some examples. Such examples are properly selected from research studies, projects and didactical experiences in which the authors have been personally involved (Aldon & Panero, Can digital technology change the way mathematics skills are assessed? *ZDM*, 52, 1333–1348, 2020; Arzarello & Soldano, *Compendium for early career researchers in mathematics education. ICME-13 Monographs*. Springer, 2019; Bini et al., Maths in the time of social media: Conceptualizing the internet phenomenon of mathematical memes. *International Journal of Mathematical Education in Science and Technology*. <https://doi.org/10.1080/0020739X.2020.1807069>, 2020; Bini, Robutti, & Montagnani, When they tell you that  $i^{56}=1$ : Affordances of memes and GeoGebra in mathematics. *The International Journal for Technology in Mathematics Education*, 28(3), 143–151, 2021. <https://cloud.3dissue.com/170388/199108/233436/IJTME-Vol28-3-2021/index.html>; Soldano & Sabena, Technology-based inquiry in geometry: Semantic games through the lens of variation. *Educational Studies in Mathematics*, 100(1), 7–23, 2019).

**Keywords** Digital technology · Critical thinking · Formative assessment · Inquiring-games

## Introduction

Many changes have occurred from the beginning of the seventies when a first group of MIT scientists started carrying out projects aimed at “changing, and possibly enhancing, the education and intellectual development of young children, by having them actively manipulate computers in various problem fields” (Jahnke, 1983, p. 87). Commenting on Papert’s “Mindstorms” published in 1982, Jahnke highlighted its pioneristic educational interest “to understand how computers and microcomputers’ massive invasion of the everyday life of the individual and of society will change the style and the mode of thinking, in order to develop orientations and opportunities for changing the learning processes in children” (Jahnke, 1983, p. 87). Historically, one of the first software introduced for educational purposes was the programming language called LOGO, in which commands for movement and drawing produce line or vector graphics that are visible through the motion of a small turtle.<sup>1</sup> Conceived to teach programming concepts, only later it was employed to make students understand, predict, and reason about the turtle’s motion by imagining to move if they were the turtle, namely what Papert called a *body-syntonic reasoning*. The research and didactic interest in studying how to effectively integrate technology at school still relies on developing students’ critical thinking and problem-solving skills. Moreover, as highlighted by recent surveys (e.g., Clark-Wilson et al., 2020), the focus has consequently shifted also on the

---

<sup>1</sup><https://turtleacademy.com/>

teachers' role when using technology to improve teaching practices and students' learning. The emergent perspective was that any digital device has to be seen as students' and teachers' ally, rather than a replacing machine in calculating, thinking or designing activities. This vision led to the study unit that Borba and Villarreal (2005) named "humans-with-media" and to the necessity of focusing on the reorganisation of mathematical thinking that is implied by this unit.

The integration of digital technology led to gradually reorganising the way mathematics, science, and technology itself are thought, conceived, taught, learnt and assessed. As highlighted in 2007 by Rocard's report concerning the future pedagogy of science education: "Science literacy is important for understanding environmental, medical, economic and other issues that confront modern societies, which rely heavily on technological and scientific advances of increasing complexity" (Rocard et al., 2007, p. 6). In the first two decades of the third millennium, despite the fact that science literacy remains a crucial skill, OECD surveys indicate that young students' performances in mathematics<sup>2</sup> and science<sup>3</sup> are alarmingly decreasing. The integration of technology in mathematics and science education then appears as fundamental and unavoidable; moreover, in these last years, with the spreading of the Covid-19 pandemic, such an integration has become more and more essential and urgent.

This chapter aims at highlighting the main important issues that have been addressed using technology for teaching and learning mathematics, providing examples of effective practices, and formulating open challenges and future goals for researchers and teachers.

After the literature review based on various and rich existing surveys on this theme, we outline the theoretical frame which guided our work and present two significant examples of effective didactic practices with technology. The first example addresses the challenges of designing an inquiring-game activity in such a way that it can support students in discovering and conjecturing geometry theorems. The second example faces the challenge of combining digital culture and mathematics teaching making the latter become closer to students' interests and extra-school life.

## Theoretical Frame and Literature Review

When computers were introduced in mathematics teaching in the seventies, researchers and teachers focused primarily on how digital tools might be used to improve students' learning. Since that first introduction, the most investigated mathematical fields have been arithmetic and geometry. Computers indeed can provide an extremely performant supporting tool for calculation, and also a rich virtual environment that can support students' visualisation activity and geometrical

---

<sup>2</sup><https://data.oecd.org/pisa/mathematics-performance-pisa.htm>

<sup>3</sup><https://data.oecd.org/pisa/science-performance-pisa.htm>

reasoning. Reading the phenomenon through modern lenses, researchers in mathematics education would say that it had to be analysed the *semiotic potential* of the artefact (Bartolini Bussi & Mariotti, 2008), which means to deepen the study of what the object is meant for, what mathematical concepts its working underlies, which mathematical signs it allows students to produce, how students might use it. This is a necessary reflection, usually conducted a priori by the teacher, and it is fundamental if the artefact is a digital or virtual one, since all the affordances and limits of the object have to be considered properly. Moreover, an artefact becomes an instrument for its user through a process called *instrumental genesis*, which is a cognitive ergonomic construct that mathematics education (Artigue, 2002) borrowed from the ergonomic theory of Rabardel (1995). Each user needs to appropriate the artefact, by associating it with specific schemes of use which may (or may not) be those for which the artefact has been created. Instrumentation is the process responsible for the creation of the scheme of use, while the parallel process of instrumentalization is the most creative part where the subject imagines possible uses of the artefact, eventually modifying and adapting it to his/her purposes.

### ***Technology for Visualising, Representing and Manipulating Mathematical Objects***

As stated by the famous Duval's claims, "there is no noesis without semiosis" (Duval, 1993, p. 40), which means that there is no conceptual understanding without passing through the signs that represent the object. Mathematical objects are accessible just through their representations. In this perspective, technology has been used to support the visualisation, representation and manipulation of mathematical objects, such as geometrical figures and constructions, functions and graphics, algebraic formulas, arithmetic expressions, etc.

For this purpose, Noss and Hoyles (1996) conceived the computer as a channel to understand the process of meaning-making, because it leads all users to communicate in the language of the used software or of the software's "microworld". Some first examples of microworlds in the arithmetic-algebraic domain were *Ti-Nspire* calculators,<sup>4</sup> with which equations and systems of equations can be solved with respect to a declared variable, and within specified numerical sets. Also the interactive *AlNuset*<sup>5</sup> is an example of software developed to connect the study of algebra, numerical sets and functions for secondary school mathematics. Other well-known examples in the geometrical field are Dynamic Geometry Systems (DGSs) or Environments (DGEs), like *Cabri*<sup>6</sup> or *GeoGebra*<sup>7</sup> which combine geometrical,

---

<sup>4</sup><https://education.ti.com/en/products/calculators/graphing-calculators/ti-nspire-cx-ii-cx-ii-cas/>

<sup>5</sup><http://www.alnuset.com/en/alnuset/>

<sup>6</sup><https://cabri.com/en>

<sup>7</sup><https://www.geogebra.org/>



graphical, algebraic and tabular registers, allowing users to visualize the simultaneous and interconnected change of semiotic frames when manipulating representations (for a historical overview of DGSs see Prado et al. in the same issue). This helps students to deal with the multifaceting of mathematical objects and conjecture mathematics properties.

In particular, studies show that a DGS can be motivational for students, because they gain a better understanding and visual grasp of the mathematics they are investigating (Garry, 1997). [...] Moreover, a DGS can be used to overcome some of the difficulties encountered when approaching proof in Geometry, by providing visual feedback and supporting the construction of situations in which ‘what if’ questions can be asked and explored (DeVilliers, 1997, 1998). (Baccaglioni-Frank, 2010, p. 7)

The main characteristic of these digital tools is their interactive mode and dynamicity. While manipulating algebraic equations, inequalities or systems, or exploring a construction in a DGE, students mobilise conceptual and procedural knowledge underlying the construction, with the consequence of questioning, consolidating and widening it. In DGEs one of the main affordances is the possibility (or impossibility) of *dragging* points and elements of a geometrical construction, which are created with specific mathematics properties, such as belonging to another element, being the intersection of other elements, changing coordinates within a given range, describing a geometrical locus depending on the movement of another element and so on. Different kinds of dragging have been studied in literature (e.g., Arzarello et al., 2002; Baccaglioni-Frank, 2012; Olivero, 2002) together with the reasoning and the cognitive activities that they trigger and foster in the students’ minds. In particular, dragging can be used to test whether an accomplished construction is correct or to formulate conjectures on a given construction. In both cases, it is a matter of developing the schemes of use for appropriating the tools and their affordances. The aspect of dragging will be central in our first example (see section “[Inquiring-Game Activities within DGE to Discover Geometry Theorems](#)”).

### ***Technology to Enrich and Gamify Mathematical Tasks***

It is not rare that students see mathematics as a cold, abstract and difficult discipline, and their negative attitude towards the discipline may seriously impact their motivation to learn mathematics and tackle mathematics problems. In this perspective, games are used to create fascinating environments to provide students with positive experiences with alive, playful and fun mathematics (Ernest, 1986). For a long time games were absent from the classroom. Indeed, this has been the case as long as pedagogy was teacher-centred. On the one hand the pedagogical revolution of making education student-centred by taking into account students’ own psychology made it possible to consider games as teaching and learning tools. On the other hand, technology facilitating an individualisation of teaching eased the introduction of games in teaching.

Starting from kindergarten and primary school, usually within specific research projects, different mathematics-based applications have been created and experimented in the classrooms to face mathematical situations where pupils can actively explore, construct and validate specific mathematical concepts. To give an example, we refer to the *TouchCounts* app,<sup>8</sup> which addresses counting, addition, subtraction, and equipartition for children aged 3–8. This app is meant to develop children’s abilities to perceive and comprehend numbers and arithmetic concepts, through tangible explorations involving their fingers, hands and body gestures. Another example is the online *Exploding dots experience*<sup>9</sup> which offers the possibility to play with the place-value property of our decimal numerical system (or with other bases), exploiting the iconic representation of numbers to solve and conceptually understand arithmetic computations. Other virtual environments have been created to play with mathematics also in informal or non-formal learning contexts. It is the case of educational escape rooms<sup>10</sup> or apps such as the German *Math-city maps*.<sup>11</sup> The latter proposes (and gives the possibility to propose) trails in different cities with mathematical problems tailored to the cities’ specific characteristics or places. Game-based learning is also at the core of mathematics-based video games such as *Variant: Limits*,<sup>12</sup> an immersive calculus game developed by the Mathematics Department of Texas A & M University in association with Triseum. The game presents an experiential exploration of a 3D virtual environment that engages students to play and learn about functions, limits, continuity and asymptotes. While playing, students are prompted by the game mechanism in solving a series of increasingly challenging calculus problems, acquiring and directly applying the knowledge in the gamified environment. A validating study conducted in the 2017/2018 academic year by Triseum with the European Schoolnet, involving educators from Greece, Italy, Norway, Poland and Portugal, positively measured the effectiveness of game-based learning on students’ knowledge acquisition and on behavioural, emotional, cognitive and agentic engagement (Tiede & Grafe, 2018). Finally, this category also includes educational robots (like *Bee-bots*, *Blue-bots* or *Thymio*) that can be used to develop geometrical and visual-spatial skills related to orientation and to cartesian plane study.

All these apps and games promote perceptual-motor learning, which is a kind of learning based on movement, body and senses: “The perceptual-motor system, precisely because it is more adapted, operates more naturally and spontaneously: it does not need awareness, it does not require concentration, it does not make us fatigued, it does not tire us and it is much faster” (Antinucci, 2001, pp. 15–16). Furthermore, the main characteristic of such learning environments is the motivational boost. As highlighted by Ernest (1986): “Playing games demands

---

<sup>8</sup><http://touchcounts.ca/about.html>

<sup>9</sup><https://www.explodingdots.org/>

<sup>10</sup>See, for instance, the European *School Break project*: <http://www.school-break.eu/>

<sup>11</sup><https://mathcitymap.eu/de/>

<sup>12</sup><https://triseum.com/variant-limits/>

involvement. Children cannot play games passively, they must be actively involved, the more so if they want to win. Thus games encourage the active involvement of children, making them more receptive to learning, and of course increasing their motivation” (p. 3). And if games at school are technology-aided, a concern to keep in mind has already been well expressed by Antinucci:

[...] if the school does not take gaming seriously, the computer at school will end up like the ‘audiovisual aids’ – and in general like all the technologies that have been knocking in vain at the door of the school building – relegated to a special ‘computer room’ as a useful (to whom?) complement to the fundamental (and, of course, traditional) didactics.<sup>13</sup>

This aspect of motivation through technology-enhanced mathematical activities will be deepened in the second example (see section “[Mathematical Internet Memes as Educational Resources](#)”).

## ***Technology to Orchestrate and Instrument Mathematical Discussion***

Student-centred pedagogical revolution mentioned in the previous section led to making students active also in the classroom discourse. In line with this, mathematical discussion became widely recognised in literature as a staple of classroom discourse and a key step in accompanying students’ growth into mathematically literate adults in a constructive epistemology perspective (Bartolini Bussi et al., 1995; Richards, 1991; Stein et al., 2008). A productive mathematical discussion takes place when teachers and students interact using the *inquiry math* language, built up of “asking mathematical questions; solving mathematical problems [...]; proposing conjectures; listening to mathematical arguments” (Richards, 1991, p. 15).

To foster a culture for inquiry in the classroom, several steps are needed: (1) conversations between teacher and students and among students have to be allowed, (2) these conversations should revolve around a *consensual domain* (Maturana, 1978), i.e., a domain of interconnected and common language that supports students’ participation and allows communication to take place.

Modern digital technology offers a variety of tools that can support teachers in establishing the consensual domain that provides the right context for the emergence of the inquiry math language, on the condition that an effort is made to use this technology as a means to stimulate discussion in a student-centred perspective, fostering bi-directional exchanges between teacher and students and among students. In fact, technology in itself is not enough to nurture communication: as Drijvers (2015) shows in his study, technology-rich environments can be used both in a teacher-centred way to provide students with top-down explanations or in a student-centred way to elicit bottom-up conjectures and arguments.

---

<sup>13</sup>Retrieved from the article at: <http://dienneti.com/software/articoli/computer.htm>

Nevertheless, if technology is used to “work together, to share the products of our solving problem strategies, to discuss around a theme, to give or receive feedback on our work in real-time” (Robutti, 2010, p. 77) it becomes a powerful asset to transform the class group into a learning community (Bielaczyc & Collins, 1999) in a constructive epistemology stance.

In Table 14.1, we list a sample of software and online apps suitable to instrument and orchestrate (in the sense given by Trouche, 2004) mathematical class discussion, together with suggestions of use in a mathematical inquiry perspective. Our choice focuses on online digital tools that allow multi-user and collaborative work so that the digital space can become a shared space where real bi-directional communication is nurtured and fruitful mathematical discussion that yields to knowledge construction can take place. All selected tools provide an interface that displays users’ contributions in real-time, thus enabling synchronous whole-class discussion.

### ***Technology to Assess Mathematical Learning***

A relevant part of teachers’ activity is dedicated to assessment, which in the history of education evolved from being “simply” summative to combining summative and formative elements. This evolution was made possible through the increasing relevance given to feedback for accompanying students in their learning processes (Hattie & Timperley, 2007; Taras, 2005). Technologies can significantly support teachers in assessing students’ learning, in both summative and formative ways. A well-known application that can be used with this aim is *Kahoot!*,<sup>14</sup> a game-based learning platform which allows students to answer online quizzes through mobile devices and provides immediate feedback. Teachers can create questionnaires in the form of multiple choice tests and true/false questions or use ready-made ones. Another example of online response systems is *Socrative*,<sup>15</sup> which allows the user also to create short answer items. Classroom response systems, such as clickers, quizzes and surveys, motivate and capture students through gamification and technological elements and, at the same time, support teachers and learners themselves in detecting and discussing mistakes and needs. Indeed, such systems allow teachers to easily collect data about students’ understanding, and usually also process them giving a picture of each individual student’s as well as of the entire class achievement.

In this way, technology can support summative assessment, since the teachers can immediately check students’ products and, if answers are displayed in the classroom, also students themselves can evaluate their performance on the different questions and topics. However, this would be a superficial use of the technological affordances at stake. The real challenge of integrating technology into assessment practices is to

---

<sup>14</sup><https://kahoot.com/>

<sup>15</sup><https://www.socrative.com/>

**Table 14.1** Digital tools for instrumentation, instrumentalization and orchestration of mathematical class discussion

Instrument		Mathematical Discussion	
Artefact	Scheme of use	Instrumentalization	Orchestration
Digital shared boards (e.g., Padlet, <sup>a</sup> Flipgrid, <sup>b</sup> Lino <sup>c</sup> )	The account owner can create and share: - Digital boards where content (images, videos, texts) can be uploaded by the account owner and by those authorised by him/her. Reactions and comments to the shared content can be enabled by the account owner (Padlet only).	The teacher publishes some content on the digital board: an open problem, a triggering question, an image, a video. The content is shared with students: Individually through the link and/or collectively using an interactive whiteboard.	The teacher prompts students to: - Reflect on the shared content and make observations, conjectures and argumentations orally or in the form of reactions or written comments; - Contribute to the development of the discussion by uploading their own content to the shared board, e.g., photos of individual solutions to the given problem.
Real-time audience response system (e.g., Wooclap <sup>d</sup> )	The account owner can create and share: - Brainstorming activities producing word clouds; - Live polls; - Matching activities; - Image labelling activities. Reactions and messages can be enabled by the account owner.	The teacher creates the chosen interactive activity on the webapp. The activity is shared with students: individually through the link and/or the automatically generated QRcode. Answers given by students can be viewed in real-time on an interactive whiteboard.	The teacher prompts students to: - Interpret and discuss the word cloud (for brainstorming activities); - Reflect and discuss on the different given answers (for polls and other activities).
Interactive timelines webapp (e.g. Sutori <sup>e</sup> )	The account owner can create and share: - Interactive scroll-down timelines with embedding options for text, images, videos, links, quiz questions. Students' subscription is needed to allow contribution.	The teacher can create: - A complete timeline; - A timeline draft to be completed collaboratively by students. Timelines are shared with students individually through the link and/or collectively using an interactive whiteboard.	For teacher-created timelines: the teacher prompts students to discuss the content of the timeline, playing videos and answering the quiz questions. For student-created timelines: the teacher prompts students to present their work and discuss it with classmates.
Collaborative mind mapping tools (e.g., Miro <sup>f</sup> )	The account owner can create and share: - Collaborative boards to brainstorm and map out connections between	The teacher can create: - A complete mindmap; - A mindmap with missing elements to be filled in by students;	For teachers-created mindmaps: the teacher prompts students to discuss the content of the map, arguing about the

(continued)

**Table 14.1** (continued)

Instrument		Mathematical Discussion	
Artefact	Scheme of use	Instrumentalization	Orchestration
	concepts and ideas. Boards can be shared in editing mode via email.	- A mindmap draft to be completed by students. Mindmaps are shared with students individually through the link and/or collectively using an interactive whiteboard.	choice of connections and nodes. For students-created mindmaps: the teacher prompts students to present their work and discuss it with classmates.

<sup>a</sup><https://padlet.com/>

<sup>b</sup><https://info.flipgrid.com/>

<sup>c</sup><http://linoit.com/home>

<sup>d</sup><https://www.wooclap.com/>

<sup>e</sup><https://www.sutori.com/>

<sup>f</sup><https://miro.com/mind-map/>

evaluate and support students' processes and learning paths. Thus, evidence about student achievement is not only elicited, but mostly "interpreted, and used by teachers, learners, or their peers, to make decisions about the next steps in instruction that are likely to be better, or better founded, than the decisions they would have taken in the absence of the evidence that was elicited" (Black & Wiliam, 2009, p. 9). This teaching-learning practice leads to *formative assessment*, that is assessment for learning, which can be implemented through five key strategies: clarifying and sharing learning intentions and criteria for success; engineering effective classroom discussions and other learning tasks that elicit evidence of student understanding; providing feedback that moves learners forward; activating students as instructional resources for one another; activating students as the owners of their own learning.

Studying the role of technology in effectively implementing formative assessment strategies has been the goal of the European project FaSMEd (*Formative Assessment in Mathematics and Science Education*),<sup>16</sup> that ran from 2014 to 2016, and identified three main functionalities through which technology can amplify the teachers' and the students' actions: sending and displaying; processing and analysing; providing an interactive environment. When a digital artefact is used by the teacher, by the individual students or by a group of students, with a specific functionality to implement a particular formative assessment strategy, it becomes what Aldon and Panero (2020) called *formative assessment instrument*. The scheme of use is given by the triplet: agent, functionality, strategy. For example, in order to orchestrate a fruitful mathematical discussion (see section "[Technology to Orchestrate and Instrument Mathematical Discussion](#)"), the teacher asks students to work on a given problem in groups on their tablets, and uses a connected classroom technology (i.e., *NetSupport School*<sup>17</sup>) to collect and display on the interactive

<sup>16</sup><https://microsites.ncl.ac.uk/fasmedtoolkit/>

<sup>17</sup><https://www.netsupportschool.com/>

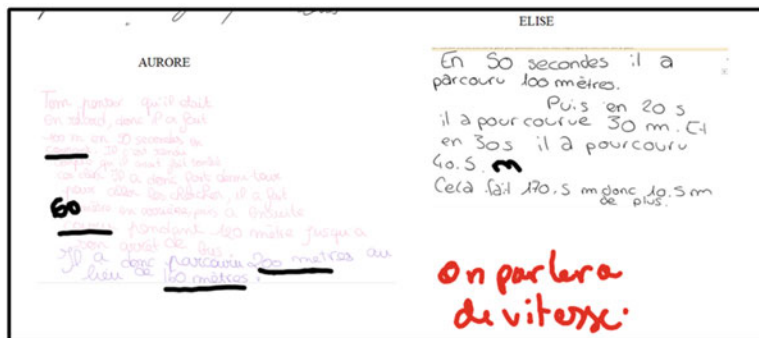


Fig. 14.1 Some different students' answers on the whiteboard

whiteboard how the different groups have solved the problem. The technological artefact *NetSupport School* has been associated with the following scheme of use: agent–teacher; functionality–sending and displaying; strategy–engineering an effective classroom discussion eliciting student understanding.

Technology allows the teacher to display *all* the students' answers, exactly *as they have been proposed*, to zoom in, discuss, complete, underline details and write notes on each particular answer (as shown in Fig. 14.1). The teacher's formative assessment strategies are thus reinforced and augmented by the use of technology.

With the aim of supporting formative assessment with technology, in recent years, the Israeli research group, headed by Prof. M. Yerushalmy at Mathematics Education Research and Innovation Centre, has been developing digital systems which provide real-time feedback on complex student performances. It is the case of *Seeing the Entire Picture* (STEP) system (Olsher et al., 2016), which uses computer checking of students' work for formative assessment purposes. Students enter in STEP interactive diagrams as answers to a given task and the system, using implemented automatic filters, is able to provide immediate assessment information to individual students and global analysis of all the answers. Filters, developed by Y. Luz, support the formative assessment of higher-order mathematical skills, such as students' inquiring processes (Soldano et al., 2019), the comprehension of terms and concepts and the comprehension of the logical status of stating (Luz & Yerushalmy, 2019).

### ***Technology for Distance Training***

In the field of tertiary education, and in particular of teacher education, numerous remote training experiences had been successfully carried out all over the world, especially when the goals or the context demanded it. This is the case of MOOCs (Massive Open Online Courses) which developed as a remote training possibility, in very large countries or when different countries were involved. Such courses, mostly based on asynchronous engagement through videos, quizzes and forums, can have

different durations and ways of certification: some of them ask for a personal creative work to be produced, individually or in collaboration with other participants. Synchronous moments can also be organised in webinar mode, with the possibility to ask questions in a common chat. To give an example, eFAN Maths<sup>18</sup> (*Enseigner et Former Avec le Numérique en Mathématiques*) is a 5-week MOOC delivered by the Ecole Normale Supérieure de Lyon for all the French-speaking mathematics secondary school teachers around the world. For the remote parts of these courses, specific platforms are used to present and exchange materials (e.g., Moodle,<sup>19</sup> Coursera<sup>20</sup>) or connected classroom technologies are employed to create a communication network between teacher and students, and among students (e.g., Google Classroom,<sup>21</sup> Microsoft Teams<sup>22</sup>). These systems are often replaced or integrated by the use of software like Google Meet,<sup>23</sup> Skype<sup>24</sup> or Zoom<sup>25</sup> that allow organising remote conferences and meetings.

Blended solutions are also possible, with part of the work in a remote mode and another part in presence at the university. In Italy, one important example in the field of mathematics teacher education has been the *m@t.abel project*,<sup>26</sup> a national-scale training program involving teachers of all grades of compulsory school to experiment and document teaching-learning paths on crucial nodes of Italian school curriculum. In this project, teachers and educators, coming from various Italian universities, worked together, both in presence and in remote modalities, to design and analyse such educational paths for pupils. One well-known blended modality gave origin to an innovative didactic approach called Flipped Classroom, in which the “traditional” class, consisting in course and application, is inverted: the theoretical content is reserved for the students’ home studying (usually through video materials), and the application and in-depth study is done in presence in classroom (usually in groups).

In such contexts, trainers’ tasks and challenges as well as trainees’ forms of collaboration and engagement change (Aldon et al., 2019). For trainers the main concerns of remote teaching are related to design (e.g., structure, modules, materials, communication tools) and assessment (e.g., how to assess trainees’ participation, which forms of assessments to use). For trainees, the main features of remote learning consist in the opportunities to attend courses which would be difficult to access otherwise, to proceed at one’s normal learning pace, and to collaborate and exchange ideas with colleagues coming from other school contexts.

---

<sup>18</sup><https://www.fun-mooc.fr/en/cours/enseigner-et-former-avec-le-numerique-en-mathematiques/>

<sup>19</sup><https://moodle.org/>

<sup>20</sup><https://www.coursera.org/>

<sup>21</sup><https://classroom.google.com/>

<sup>22</sup><https://www.microsoft.com/it-it/microsoft-teams/>

<sup>23</sup><https://meet.google.com/>

<sup>24</sup><https://www.skype.com/>

<sup>25</sup><https://zoom.us/>

<sup>26</sup><http://www.scuolavalore.indire.it/superguida/matabel/>



## Challenges to Be Faced

Drijvers (2015) published an illuminating study describing six cases in which digital technology has been used in mathematics teaching. He reflected on whether digital technology worked well (or not) for the student, the teacher or the researcher, and which factors may explain the success or failure. Moreover, he identified three crucial factors that support or inhibit the successful integration of digital technology in mathematics education: the design, the role of the teacher, and the educational context. In the examples chosen for this chapter we will particularly describe these three aspects. Our aim is to point out technology-related challenges that are still open for researchers and teachers in mathematics education, adding virtuous cases to those analysed by Drijvers (2015).

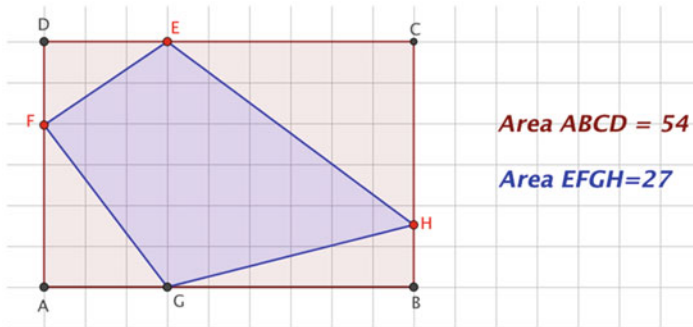
### *Inquiring-Game Activities Within DGE to Discover Geometry Theorems*

In this section it is described how and why *inquiring-game activities* (Soldano & Arzarello, 2017) can be used didactically to support the discovery of geometric theorems and deepen the understanding of the meaning of their statements, truth and validity. *Inquiring-game activities* consist in a *game* based on a geometric theorem and a *worksheet task* containing reflecting questions. Game dynamics are inspired by games of verification and falsification, known as semantical games, used in the Logic of Inquiry (Hintikka, 1998, 1999) to establish the truth of statements. Before carrying on in the description of inquiring-game activities, we should open a brief parenthesis for illustrating the semantical game dynamics. In order to establish the truth of the statement “for all  $x$ , there exists  $y$  such that  $S(x,y)$ ”, imagine a *falsifier* who controls variable  $x$  and a *verifier* who controls variable  $y$ . The *falsifier* chooses a value for  $x$  and the *verifier* should find the suitable value of variable  $y$  that makes  $S(x,y)$  true. If, even in the worst possible scenario, the *verifier* is able to find a value for the variable  $y$  that makes  $S(x,y)$  true, then the statement is true, otherwise it is false. The possibility for the *verifier* to always win depends on the existence of a winning strategy which guarantees the truth of the statement according to Game Theory principles.

The first step of the design of *inquiring-game activities* consists in rethinking the theorem, which is the object of the didactical transposition, as a game between a *verifier* and a *falsifier*. We illustrate this creative operation on the following theorem:

When (and only when) at least one of the two diagonals of a quadrilateral inscribed in a rectangle is parallel to one side of the rectangle the area of the inscribed quadrilateral is half of the area of the rectangle.

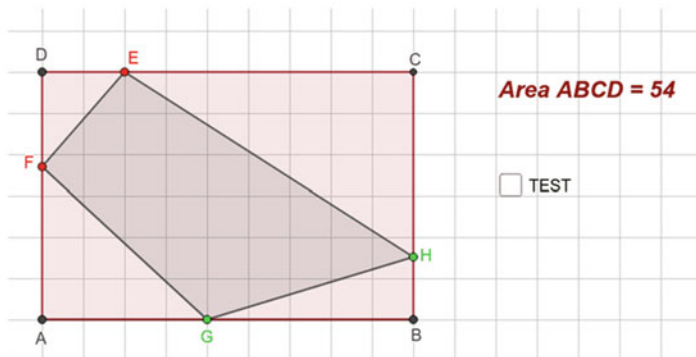
Roughly said, in order to create an inquiring-game situation we need a *falsifier* who in each match produces a different inscribed quadrilateral configuration whose area



**Fig. 14.2** Robust construction of the parallelism condition

is not the half of the rectangle area and a *verifier* who, starting from the configuration produced by the *falsifier*, transforms it into an inscribed quadrilateral whose area is the half of the rectangle area. The affordances of DGE and the dragging tool potentialities has been exploited for creating the described dialectic between the falsifier and the verifier. To this end, the parallelism condition between one diagonal of the inscribed quadrilateral and one side of the rectangle is not *robustly* constructed (Healy, 2000), but *softly* produced by the verifier's move. The property would have been robustly constructed if a couple of non-consecutive vertices (for example E and G in Fig. 14.2) of the inscribed quadrilateral were constructed as follows: vertex E as a point belonging to a side of the rectangle and vertex G as the intersection point between the line passing through E and perpendicular to the side of the rectangle to which E belongs.

If we imagine not knowing the theorem and inquiring it using the dragging tool on the robust construction retrievable at the link <https://www.geogebra.org/m/hqstgs9p>, we would observe that there are three vertices (E, F and H) of the inscribed quadrilateral which are free to move on the sides of the rectangle to which they belong and one vertex (G) which moves only when its non-consecutive vertex (E) is moved. By noticing the invariant parallelism between diagonal EG and side AD and the invariant ratio between the areas of the two quadrilaterals, it is possible to conjecture the statement of the theorem in the form of a conditional statement which links the observed invariant properties. However, this inquiring process with the dragging tool does not offer the possibility of observing what happens to the relationship between the areas if the parallelism condition would not be present. According to the variation theory (Marton et al., 2004), we could say that the so-called “contrast dimension” is absent. Within this theory, learning consists of becoming aware of the critical aspects or features that constitute an object. Learners discern critical aspects by paying attention to what varies and what is invariant. The authors identify four dimensions of variation which elicit the phenomenological experience: contrast, generalisation, separation and fusion. The contrast dimension establishes that “in order to experience something, a person must experience something else to compare it with” (p. 16). So observing what happens to the area when



**Fig. 14.3** The game implemented in GeoGebra

**Table 14.2** Rules of the game

Within your pair, establish a <i>verifier</i> and a <i>falsifier</i> . Each challenge consists of two moves and a TEST.
The <i>falsifier</i> moves points E and F, the <i>verifier</i> moves points G and H.
The first move is made by the <i>falsifier</i> whose goal is to prevent the <i>verifier</i> from reaching his/her goal.
The second move is made by the <i>verifier</i> , whose goal is to find a configuration in which the area of EFGH is half the area of the rectangle ABCD.
When the <i>verifier</i> has completed his move, the <i>falsifier</i> clicks on TEST to check if the <i>verifier</i> has reached his/her goal. If so, the <i>verifier</i> wins the challenge, otherwise the <i>falsifier</i> wins. Then click on TEST to hide the value of the EFGH area and start a new challenge.

the side of the rectangle and the diagonal of the inscribed quadrilateral are not parallel is necessary to discover that the area of the inscribed quadrilateral is half of the area of the rectangle when the side and the diagonal are parallel.

Inquiring-game activities allow the user to perceive the contrast dimension by using soft constructions of invariants and by introducing the verifier and falsifier roles. In the reported examples, a soft construction of the parallelism property is obtained by leaving the vertices of the inscribed quadrilateral free to move on the sides of the rectangle and by asking the verifier to produce a configuration in which the ratio between the areas is 1:2. The game is played on the geometric construction shown in Fig. 14.3 (link <https://www.geogebra.org/m/ng6gyspz>) following the rules reported in Table 14.2.

ABCD is a rectangle with fixed vertices and EFGH is a quadrilateral inscribed in the rectangle, whose vertices are draggable on the side of the rectangle to which they belong. Two consecutive vertices of the inscribed quadrilateral – E and F (red points in Fig. 14.3) – are moved by the *falsifier*, who in each move produces a different inscribed quadrilateral configuration. The other two vertices G and H (green points in Fig. 14.3) are moved by the *verifier* who reacts to the *falsifier*'s move by producing an inscribed quadrilateral whose area is the half of the rectangle's one.



**Fig. 14.4** (a) *Falsifier's* move. (b) *Verifier's* not expert move. (c) *Verifier's* expert move

During the first matches, the *verifier* does not know that the parallelism between a diagonal of the inscribed quadrilateral and a side of the rectangle guarantees the required relationship between the areas of the two figures, hence the *verifier* would try to reach the goal using visual or empirical strategies (i.e., visually estimating the magnitude of the two areas, counting the squares and part of squares of the grid covered by the figures, looking for symmetries). The winner of each challenge is established by clicking on the TEST button created through the check box tool, which allows users to show and hide the associated value in the Graphic view of GeoGebra by clicking on it.

Figure 14.4a shows a hypothetical configuration produced by the *falsifier*, while Fig. 14.4b, c show possible winning configurations produced by the *verifier*.

During the first moves, many students produce configurations in which both diagonals are parallel to the rectangle sides, similar to the one shown in Fig. 14.4b. After some matches, they discover that it is not necessary that both diagonals be parallel to the sides and start producing configurations such as the one shown in Fig. 14.4c. This is an example of “expert move”, generally performed by students at the end of the activity, after having deeply inquired the situation and discovered that the necessary condition for the required area relationship is to have just one of the two diagonals of EFGH parallel to one side of ABCD. These different ways of reaching the verifier’s goal could be exploited in a class discussion following the exploration activity for reflecting on necessary and sufficient conditions of the theorem statement.

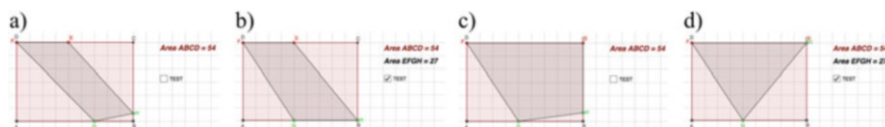
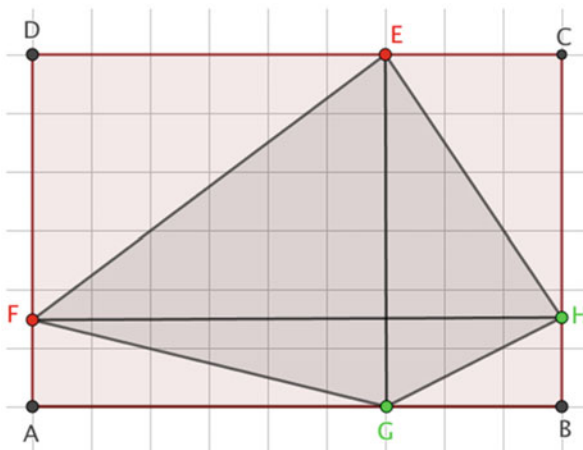
The parallelism condition is not easy to be discovered: it could happen that students justify why the produced configuration is a winning one without even noticing it. For example, students could see rectangles and triangles inside ABCD as shown in Fig. 14.5 and notice that the triangles which cover rectangle ABCD are made by two equal pairs of triangles which cover EFGH.

Moreover, the *falsifier*, looking for a strategy to defeat the *verifier*, generally moves E and F at the extreme (such as Fig. 14.6a in which  $F=D$  and Fig. 14.6c in which  $F=D$  and  $E=C$ ), creating the condition for special configuration such as the trapezoid in Fig. 14.6b and degenerative ones such as the triangle in Fig. 14.6d.

During the game it is important that both students make experience of the role of the *verifier* and the role of the *falsifier*, hence in the task it is required to exchange roles and play again.

Once the game is designed and the rules of the game are clearly written for students, the second step of the design is the production of the worksheet. Some students, especially in low degrees, play without inquiring geometric properties: they

**Fig. 14.5** *Verifier's* way to notice winning configurations



**Fig. 14.6** (a–c) *Falsifier* moves points in extreme positions. (b–d) *Verifier* produces special cases

produce winning configurations, special configurations or degenerate ones without noticing their geometric peculiarities. The questions contained in the worksheet are meant to focus students' attention on the geometric counterpart of the game. The first question we recommend asking is:

Which geometric condition allows the *verifier* to reach the goal for every move made by the *falsifier*?

This question requires to discover and to make explicit the geometric winning strategy that ensures the area of EFGH to be half of the area of ABCD. The winning strategy can be expressed in various ways: the diagonal(s) of EFGH must be parallel to side(s) of ABCD; the diagonal(s) of EFGH must be perpendicular to side(s) of ABCD; opposite vertices of EFGH must be symmetrical with respect to axis of symmetry of ABCD passing through the midpoints of their sides. It is possible that students initially identify conditions that are sufficient but not necessary, such as: both diagonals of EFGH must be parallel/perpendicular to the sides of ABCD. We also expect that students formulate incorrect winning strategies such as: the diagonals of EFGH should be perpendicular to each other, generalising an accidental property which is observable in configuration similar to Fig. 14.5.

The second question we recommended to ask is:

Which theorem did you discover? Formulate it in the "If... then..." form.

This question explicitly requires conjecturing the statement of the theorem, using as hypothesis the winning strategy and as thesis the observed relationship between the areas, for example: if a diagonal of EFGH is parallel to one side of ABCD then area of EFGH is half of area of ABCD.

Finally, the third questions would be:

Write the hypothesis, the thesis and prove the theorem.

After having explored the situation deeply through the game we expected that the production of the proof would not be difficult since generally students observe and discuss the geometric properties which guarantee the relationship between the areas while looking for the winning configuration and while investigating why the produced configuration is a winning one.

### ***Mathematical Internet Memes as Educational Resources***

In this section we describe why and how mathematical memes, the mathematical mutations of the digital phenomenon of Internet memes, can be used by teachers to enrich mathematical teaching, bridging the cultural and technological divide that separates informal out-of-school learning environments and traditional school-based learning environments.

In the last 20 years, the fast evolution of the Internet digital technology has produced a technological discontinuity between generations, and therefore between teachers and learners, and between school-based and out-of-school learning contexts (Bronkhorst & Akkerman, 2016).

This is not merely a technical evolution, it is a cultural change which is particularly evident when we look at the difference between how young learners access and share information and knowledge outside the school environment and how they are exposed to them inside schools (Clark et al., 2009).

The focal point in this difference is not simply the accessibility of notions but stands in terms of being involved in a participatory way in the construction of knowledge and not simply being exposed to it as consumers (Ito et al., 2013; Jenkins, 2006, 2009; Thomas & Seely Brown, 2011).

Internet Memes (or simply memes) are considered emblematic products of the 21-st century participatory digital culture (Shifman, 2014). They are humorous digital artefacts, typically *mutations* of popular images with user-added text. Memes multiply and spread after being purposefully reinterpreted by Internet users following strict socially-enforced rules that are institutionalised in meme encyclopaedias as *KnowYourMeme*.<sup>27</sup> Memes are quick and easy to create, using meme-generator websites as *Imgflip*<sup>28</sup> that provide user-friendly interfaces to combine

<sup>27</sup><https://knowyourmeme.com/>

<sup>28</sup><https://imgflip.com/memegenerator>

images and texts, and host repositories of users' productions. On the one hand the process of creating and sharing memes on the Web allows authors to participate in the digital discourse, expressing their own personal meanings: feelings, political protest or mathematical ideas (Bini et al., 2020; Milner, 2016; Shifman, 2014). On the other hand, the interaction that takes place around shared memes, typically in the form of threads of comments, provides space for explanations and clarifications about the subject of the meme, and thus for knowledge-building according to the digital native culture.

Mathematical Internet memes (or simply, mathematical memes) are mutations of Internet memes carrying a mathematical content. They are shared mostly inside dedicated online communities, hosted in social networking websites such as Reddit, Instagram or Facebook. Analysing the interaction initiated by mathematical memes within these communities, Bini et al. (2020) showed that mathematical memes are perceived as representations of mathematical statements, written in a new hybrid language which combines mathematical and memetic elements, and that they are endowed with an epistemic power to initiate spontaneous argumentation processes.

Examples of memes and mathematical memes are presented in Fig. 14.7. The starting point is an image, in this case a screenshot from a video of a man smacking cards on a table (Fig. 14.7a). Through a process of "collective semiosis" (Osterroth, 2018, p. 6), the image becomes popular and acquires the metaphorical meaning to depict real or symbolic aggressive behaviours. Retaining this metaphorical meaning, the image – by means of different added texts – is *mutated* to represent (Fig. 14.7b) the historical event of Stalin's winter counteroffensive bringing an end to German Operation Barbarossa and (Fig. 14.7c) the typical mathematical mistake of using L'Hôpital's rule for any limit presenting a  $\infty/\infty$  or  $0/0$  indeterminate form, without verifying the validity of the other hypotheses.

In both mutations (Fig. 14.7b, c) the *semiotic potential* of the artefact (Bartolini Bussi & Mariotti, 2008) is perceptible. The constitutive elements of *humour*, *intertextuality* and *anomalous juxtapositions* (Knobel & Lankshear, 2005) merge to convey proper cultural content, whose understanding requires a *multiliteracy*

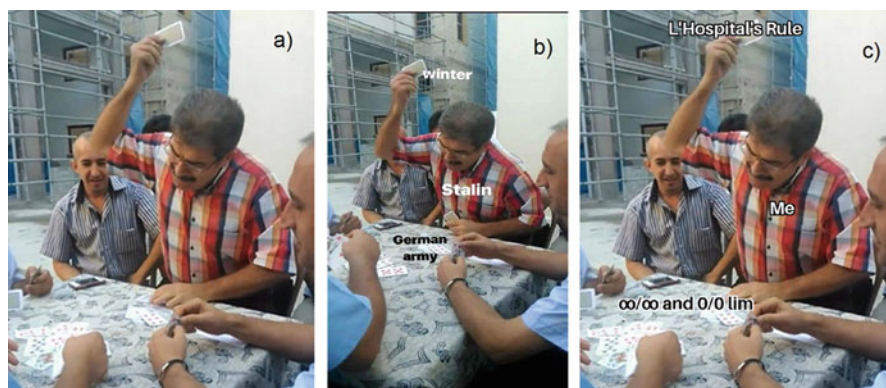


Fig. 14.7 Mutations in Internet memes. (Source: Reddit)

(Cope & Kalantzis, 1999): a non-trivial combination of *online* digital culture, to recognise the image and its metaphorical meaning, and *offline* traditional culture, in these cases historical or mathematical.

Focusing on the mathematical example, following Bini et al. (2020) we can read it as the memetic representation of the statement: “In evaluating a limit, an indeterminate form of the  $0/0$  or  $\infty/\infty$  kind is a necessary but not sufficient condition to apply L’Hôpital’s rule”. Therefore, we can imagine a number of possible school uses of this artefact, aimed at fostering mathematical reasoning: determination of the truth-value of the statement, argumentations, proofs and clarifications around the embedded mathematical idea (Mariotti, 2006; Tabach et al., 2012).

Despite their educational potentialities, mathematical memes are not straightforward to integrate into a teaching practice: educators need support to adapt the artefact to the teaching practice, i.e., to interpret the mathematical statement represented by mathematical memes, and vice versa to adapt the teaching practice to the artefact, i.e., to design tasks involving mathematical memes that can be fruitfully assigned to students.

The triple-s construct of the *partial meanings* of a meme (Bini & Robutti, 2019) can provide support in both directions. The triple-s is a semiotic tool that enables the reader to recognise and decode the layers of meanings necessary to understand a mathematical meme. These layers of partial meanings are classified as:

- Social meaning: the metaphorical value of the image as enforced by social semiosis, that can be retrieved from meme encyclopaedias as *KnowYourMeme*;
- Structural meaning: the layout and font of the user-added texts, that is also enforced by social semiosis and retrievable from *KnowYourMeme*, and is automatically provided by meme generator websites as *Imgflip*;
- Specialised meaning: the specific topic addressed by the mutations performed by the author of the meme.

The interconnected interpretation of these three partial meanings gives what Bini and Robutti (2019) call the *full meaning* of the meme, which corresponds to the represented mathematical statement. Thus, applying the triple-s, teachers are guided in the process of extracting and interpreting meaningful data to decode image-based memes, connecting the new artefact to a known mathematical object (the statement). This is a passage that supports the *instrumentation* of the artefact and its adaptation to the teaching practices.

Figure 14.8 shows a view of the *KnowYourMeme* encyclopaedia page for the previously discussed meme. The introductory information given is the image with its social name (“Man Smacking Cards Down on Table”) and origin, the structural meaning (“object labelling image”, namely texts are to be added as labels onto the characters/objects of the image) and the social meaning (“expresses an aggressive interjection or addition”). Scrolling down on the page (not shown), various mutations of the meme are given.

Figure 14.9 shows a view of the meme-generator interface in the *Imgflip* website for the same meme. Here we see the image on the left, and on the right the three text fields for the user-added text (text1, text2 and text3): once the user types in the text, it



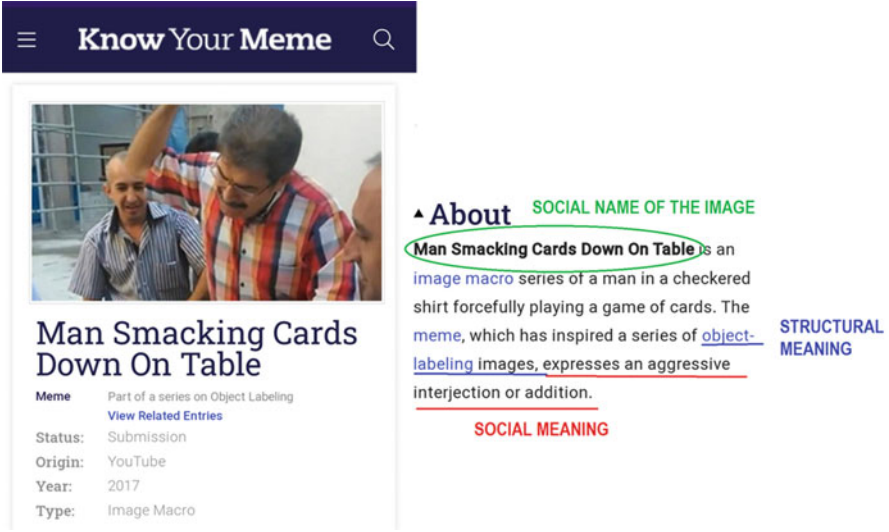
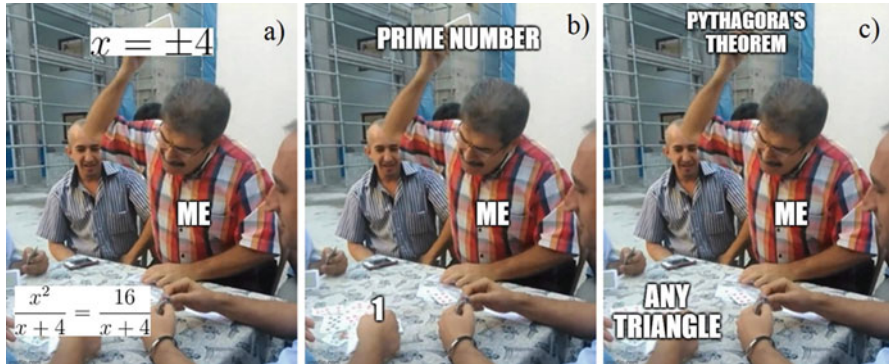


Fig. 14.8 KnowYourMeme interface showing the social and structural meanings



Fig. 14.9 Meme generator website interface

automatically appears on the image in the correct font and position. Mathematical formulas can be written with another program (Microsoft Word or LaTeX), saved as images, and then uploaded using the “add image” button and dragged to their final position on the meme, as in Fig. 14.10a. The finished meme can then be downloaded



**Fig. 14.10** (a–c) Mathematical mutations of the *Man Smacking Cards Down on Table* meme. (Created by authors)

and saved on the author’s personal device in jpeg format and can be shared directly or inserted into documents.

The triple-s can also provide support in designing tasks that involve mathematical memes, adapting the teaching practice to the artefact. The teacher can choose to fix the social and structural meanings, by selecting a particular image and leaving students free to create their mathematical mutations picking their own specialised meanings. Depending on the image selected by the teacher, students’ specific competences are fostered: for instance, an image like the “Man Smacking Cards Down on Table” example can prompt students to reflect metacognitively on typical mistakes, as exemplified in Fig. 14.10a–c. Conversely, the teacher can choose to fix the specialised meaning, encouraging students to reorganise and systematise their knowledge on a specific subject, while leaving them free to express it through their preferred image. In both cases, a whole class discussion of the productions is suggested to elicit the mathematical reasonings that lead to the constructions of the memes.

To conclude, there are some final observations to keep in mind to design school activities fruitfully involving mathematical memes: if we want to take advantage of these digital artefacts to enrich the teaching of mathematics, we must make an effort to preserve their essence as objects of the culture infusing students’ out-of-school digital life. This implies that students (and not teachers) should be at the centre of the activity as meme creators, to preserve the participatory thrust of the digital culture, and that students’ productions should not be simply handed in to the teacher, but collected in a digital or physical space openly shared inside the class-group (such as Padlet, see section “[Technology to Orchestrate and Instrument Mathematical Discussion](#)”) to preserve the social value that memes have in social networking websites, where creating a good meme is a distinctive feature.

Globalisation and technological progress drive unrelenting cultural, social, economic and environmental changes, but they also present new opportunities that educators can take on (Schleicher, in the preface of Howells, 2018). We believe

that mathematical Internet memes are one of these opportunities, as educational resources that “emphasize the movements and connections between mathematics education and other practices” (Bakker et al., 2021, p. 8).

## Conclusion

The two cases presented in this chapter are virtuous examples of integrating current technological tools into mathematics teaching practices. Teaching experiments conducted on the use of inquiring game GeoGebra activities with primary and secondary school students (Soldano & Arzarello, 2017; Soldano & Sabena, 2019) and of mathematical memes in upper secondary school (Bini & Robutti, 2019; Bini et al., 2021) showed the positive effects of the activities designed with these tools on students’ motivation and learning.

Recalling sections “[Technology for Visualising, Representing and Manipulating Mathematical Objects](#)” and “[Technology to Enrich and Gamify Mathematical Tasks](#)”, motivation is boosted, in the first case, by the dynamical features of the DGE that offers an unusual and active way of manipulating geometrical objects as well as the game character that makes the activity playful and funny; in the second case, motivation is fostered by transforming a digital object coming from extra-school life, close to students’ interests and fun sources. Nevertheless, this motivational boost is important but not the only element that makes such activities successful.

Another crucial element of success is the epistemic core of such activities. Students are exploring, conjecturing, proving, detecting typical mistakes and misconceptions, mobilising knowledge, with no apparent effort. To reach this didactic goal, as shown in section “[Inquiring-Game Activities within DGE to Discover Geometry Theorems](#)” and “[Mathematical Internet Memes as Educational Resources](#)”, the activities must be designed on an epistemic basis. The inquiring game is based on the semantical game interpretation of the proposition “For all  $x$ , there exists  $y$  such as  $S(x,y)$ ”, rendered through the concrete back and forth between *verifier* and *falsifier*. The mathematical memes require a deep understanding and mastery of mathematical concepts, properties and theorems to the point that one is able to create a joke on it, and such a joke also passes through the comprehension of the social meaning of online images and resources. Both cases develop students’ critical and creative thinking on a deep and epistemic level.

With these two cases, we intend to contribute to Drijvers’ (2015) gallery of successful cases of integration of technology into mathematics teaching practices. If we wonder, as Drijvers, whether these cases work and why, our answer is positive and the reasons rest exactly on the critical aspects that he pointed out: a specific focus on design issues, on the role of the teacher, and on the educational context of the students to which such activities are proposed. And we would add as a successful element the important reflection on the epistemic side which constitutes the source of the playful nature of the activity.

We conclude with a last reflection and concern. While writing about integration of technology in education with a focus on its historical evolution, we could not avoid thinking about the particular historical period we are passing through, in which the Covid19 pandemic has obliged everybody to experiment and cope with the massive use of technology in education. To this end, we want to raise a concern for mathematics education, and education in general. The challenges of distance teaching and learning, just mentioned in section “[Technology for Distance Training](#)” referring to adults’ learning, are extremely delicate when distance teaching is intended not for adults but for children or teenagers. In this latter case, learners’ methods for studying and elaborating information are still developing and need the teacher’s guide to receive feedback and structure. Moreover, relational and emotional issues still play an essential role in the students’ growth. These concerns are shared and discussed in recent studies about young students’ distance learning during the pandemic:

From one moment to the next, teachers are compelled to make decisions on how to encourage their students to continue their learning at a distance. [...] many colleagues all over the world worry inequality and the digital divide will only increase, because many students do not have the resources and opportunities to engage in online education. [...] Several colleagues worried that quick adoption of new technology will lead to falling back to less favorable pedagogy (e.g., transmission of knowledge or the *laissez faire* of unguided discovery). Questions were also raised what it meant to lose some embodied aspects of learning and the face-to-face interaction with peers and teachers. (Bakker & Wagner, 2020, p. 2)

This is an impoverishing trend we hope will not be taken by technology in teaching, and in particular in mathematics teaching. Quoting a recent article written by Andrea Migliorini (2022), editor of WeSchool, using digital technology for a traditional, transmissive teaching which repropose, online, the same frontal lesson that would have occurred in the classroom is not “digital teaching”. The use of technology has to be reflected and carefully designed, because the core issue of distance teaching is not “distance” but rather “teaching”.

## References

- Aldon, G., & Panero, M. (2020). Can digital technology change the way mathematics skills are assessed? *ZDM*, 52, 1333–1348.
- Aldon, G., Arzarello, F., Panero, M., Robutti, O., Taranto, E., & Trgalová, J. (2019). MOOCs for mathematics teacher education to foster professional development: Design principles and assessment. In G. Aldon & J. Trgalová (Eds.), *Technology in Mathematics Teaching* (pp. 223–246). Springer.
- Antinucci, F. (2001). *La scuola si è rotta. Perché cambiano i modi di apprendere*. Laterza.
- Artigue, M. (2002). Learning mathematics in a CAS environment: The genesis of a reflection about instrumentation and the dialectics between technical and conceptual work. *International Journal of Computers for Mathematical Learning*, 7(3), 245–274.

- Arzarello, F., & Soldano, C. (2019). Approaching proof in the classroom through the logic of inquiry. In G. Kaiser & N. Presmeg (Eds.), *Compendium for early career researchers in mathematics education. ICME-13 Monographs*. Springer.
- Arzarello, F., Olivero, F., Paola, D., & Robutti, O. (2002). A cognitive analysis of dragging practises in Cabri environments. *ZDM*, 34(3), 66–72.
- Baccaglioni-Frank, A. (2010). *Conjecturing in dynamic geometry: A model for conjecture-generation through maintaining dragging*. Doctoral dissertation, University of New Hampshire.
- Baccaglioni-Frank, A. (2012). Dragging and making sense of invariants in dynamic geometry. *Mathematics Teacher*, 105(8), 616–620.
- Bakker, A., & Wagner, D. (2020). Pandemic: Lessons for today and tomorrow? *Educational Studies in Mathematics*, 104(1), 1–4.
- Bakker, A., Cai, J., & Zenger, L. (2021). Future themes of mathematics education research: An international survey before and during the pandemic. *Educational Studies in Mathematics*. <https://doi.org/10.1007/s10649-021-10049-w>
- Bartolini Bussi, M. G., & Mariotti, M. A. (2008). Semiotic mediation in the mathematics classroom: Artefacts and signs after a Vygotskian perspective. In L. English, M. Bartolini Bussi, G. Jones, R. Lesh, & D. Tirosh (Eds.), *Handbook of international research in mathematics education* (2nd ed., pp. 746–805). Lawrence Erlbaum.
- Bartolini Bussi, M. G., Boni, M., & Ferri, F. (1995). *Interazione sociale e conoscenza a scuola: la discussione matematica*. Comune di Modena.
- Bielaczyc, K., & Collins, A. (1999). Learning communities in classrooms: A reconceptualization of educational practice. In C. M. Reigeluth (Ed.), *Instructional-Design Theories and models. A new paradigm of instructional theory* (pp. 269–292).
- Bini, G., & Robutti, O. (2019). Meanings in mathematics: Using internet memes and augmented reality to promote mathematical discourse. In U. T. Jankvist, M. van den Heuvel-Panhuizen, & M. Veldhuis (Eds.), *Proceedings of the eleventh congress of the European society for research in mathematics education*. Freudenthal Group & Freudenthal Institute, Utrecht University and ERME. <https://hal.archives-ouvertes.fr/hal-02422152>
- Bini, G., Robutti, O., & Montagnani, M. (2021). When they tell you that  $i^{56}=1$ : Affordances of memes and GeoGebra in mathematics. *The International Journal for Technology in Mathematics Education*, 28(3), 143–151. <https://cloud.3dissue.com/170388/199108/233436/IJTME-Vol28-3-2021/index.html>
- Bini, G., Robutti, O., & Bikner-Ahsbals, A. (2020). Maths in the time of social media: Conceptualizing the internet phenomenon of mathematical memes. *International Journal of Mathematical Education in Science and Technology*. <https://doi.org/10.1080/0020739X.2020.1807069>
- Black, P., & Wiliam, D. (2009). Developing the theory of formative assessment. *Educational Assessment, Evaluation and Accountability*, 21(1), 5–31.
- Borba, M. C., & Villarreal, M. E. (2005). *Humans-with-media and the reorganization of mathematical thinking: Information and communication technologies, modeling, visualization and experimentation* (Vol. 39). Springer Science & Business Media.
- Bronkhorst, L., & Akkerman, S. (2016). At the boundary of school: Continuity and discontinuity in learning across contexts. *Educational Research Review*, 19, 18–35. <https://doi.org/10.1016/j.edurev.2016.04.001>
- Clark, W., Logan, K., Luckin, R., Mee, A., & Oliver, M. (2009). Beyond web 2.0: Mapping the technology landscapes of young learners. *Journal of Computer Assisted Learning*, 25, 56–69. <https://doi.org/10.1111/j.1365-2729.2008.00305.x>
- Clark-Wilson, A., Robutti, O., & Thomas, M. (2020). Teaching with digital technology. *ZDM*, 52, 1223–1242.
- Cope, B., & Kalantzis, M. (Eds.). (1999). Introduction: Multiliteracies: The beginnings of an idea. In *Multiliteracies: Literacy learning and the design of social futures* (pp. 3–8). Taylor and Francis.

- Drijvers, P. (2015). Digital technology in mathematics education: Why it works (or doesn't). In S. J. Cho (Ed.), *Selected regular lectures from the 12th international congress on mathematical education* (pp. 135–151). Springer.
- Duval, R. (1993). Registres de représentation sémiotique et fonctionnement cognitif de la pensée. *Annales de didactique et de sciences cognitives*, 5(1), 37–65.
- Ernest, P. (1986). Games. A rationale for their use in the teaching of mathematics in school. *Mathematics in School*, 15(1), 2–5.
- Hattie, J., & Timperley, H. (2007). The power of feedback. *Review of Educational Research*, 77(1), 81–112.
- Healy, L. (2000). Identifying and explaining geometrical relationship: Interactions with robust and soft Cabri constructions. *Proceedings of the 24th PME International Conference* (Vol. 1, pp. 103–117). Hiroshima, Japan.
- Hintikka, J. (1998). *The principles of mathematics revisited*. Cambridge University Press.
- Hintikka, J. (1999). *Inquiry as inquiry: A logic of scientific discovery*. Springer Science & Business Media.
- Howells, K. (2018). *The future of education and skills: Education 2030: The future we want*. OECD. [http://www.oecd.org/education/2030/E2030%20Position%20Paper%20\(05.04.2018\).pdf](http://www.oecd.org/education/2030/E2030%20Position%20Paper%20(05.04.2018).pdf)
- Ito, M., Gutierrez, K., Livingstone, S., Penuel, B., Rhodes, J., Salen, K., & Watkins, S. C. (2013). Connected learning: An agenda for research and design. *Digital Media and Learning Research Hub*. <https://dmlhub.net/publications/connected-learning-agenda-for-research-and-design/>
- Jahnke, H. N. (1983). Technology and education: The example of the computer. *Education Studies in Mathematics*, 14, 87–100.
- Jenkins, H. (2006). *Convergence culture: Where old and new media collide*. NYU Press.
- Jenkins, H. (2009). *Confronting the challenges of participatory culture. Media education for the 21st century*. MIT Press.
- Knobel, M., & Lankshear, C. (2005). *Memes and affinities: Cultural replication and literacy education*. Miami National Reading Conference. [https://www.academia.edu/3011351/Memes\\_and\\_affinities\\_Cultural\\_replication\\_and\\_literacy\\_education](https://www.academia.edu/3011351/Memes_and_affinities_Cultural_replication_and_literacy_education)
- Luz, Y., & Yerushalmy, M. (2019). Students' conceptions through the lens of a dynamic online geometry assessment platform. *The Journal of Mathematical Behavior*, 54, 100682.
- Mariotti, M. A. (2006). Proof and proving in mathematics education. In A. Gutiérrez & P. Boero (Eds.), *Handbook of research on the psychology of mathematics education* (pp. 173–204). Brill Sense.
- Marton, F., Tsui, A. B. M., Chik, P. P. M., Ko, P. Y., & Lo, M. L. (Eds.). (2004). *Classroom discourse and the space of learning*. Lawrence Erlbaum Associates.
- Maturana, H. (1978). Biology of language: The epistemology of reality. In G. A. Miller & E. Lenneberg (Eds.), *Psychology and biology of language and thought* (pp. 27–64). NY Academic Press.
- Migliorini, A. (2022, 8 Febbraio). Il problema della Dad è la didattica non la tecnologia. In *Domani*. <https://www.editorialedomani.it/idee/commenti/dad-didattica-distanza-tecnologia-scuola-lazioni-fdnukrvk>.
- Milner, R. M. (2016). *The world made meme: Public conversations and participatory media*. MIT Press.
- Noss, R., & Hoyles, C. (1996). *Windows on mathematical meanings learning cultures and computers*. Kluwer Academic Publishers.
- Olivero, F. (2002). *The proving process within a dynamic geometry environment*. PhD Thesis, University of Bristol.
- Olsher, S., Yerushalmy, M., & Chazan, D. (2016). How might the use of technology in formative assessment support changes in mathematics teaching? *For the Learning of Mathematics*, 36(3), 11–18.
- Oostertho, A. (2018). *Semiotics of Internet memes*. <https://doi.org/10.13140/RG.2.2.12320.89605>

- Rabardel, P. (1995). *Les hommes et les technologies; approche cognitive des instruments contemporains*. Armand Colin.
- Richards, J. (1991). Mathematical discussions. In E. Von Glasersfeld (Ed.), *Radical constructivism in mathematics education. Mathematics education library* (Vol. 7, pp. 13–51). Springer. [https://doi.org/10.1007/0-306-47201-5\\_2](https://doi.org/10.1007/0-306-47201-5_2)
- Robutti, O. (2010). Graphic calculators and connectivity software to be a community of mathematics practitioners. *ZDM – The International Journal on Mathematics Education*, 42(1), 77–89.
- Rocard, M., Csermely, P., Jorde, D., Lenzen, D., Walberg-Heriksson, H., & Hemmo, V. (2007). *Science education now: A new pedagogy for the future of Europe*. Report for the European Commission. <https://www.eesc.europa.eu/sites/default/files/resources/docs/rapportrocardfinal.pdf>
- Shifman, L. (2014). *Memes in digital culture*. MIT Press.
- Soldano, C., & Arzarello, F. (2017). Learning with the logic of inquiry: Game-activities inside dynamic geometry environments. In T. Dooley & G. Guedet (Eds.), *Proceeding of CERME 10* (pp. 267–274). DCU Institute of Education & ERME.
- Soldano, C., & Sabena, C. (2019). Fostering critical thinking in primary school within dynamic geometry environments. In B. Di Paola, Y. Aberkane, & F. Cerquetti (Eds.), *Proceedings of CIEAEM 70. “Quaderni di Ricerca in Didattica (Mathematics)”*, n. 2, *Supplemento n.3* (pp. 73–79). Mostaganem (Algeria).
- Soldano, C., Luz, Y., Arzarello, F., & Yerushalmy, M. (2019). Technology-based inquiry in geometry: Semantic games through the lens of variation. *Educational Studies in Mathematics*, 100(1), 7–23.
- Stein, M. K., Engle, R. A., Smith, M. S., & Hughes, E. K. (2008). Orchestrating productive mathematical discussions: Five practices for helping teachers move beyond show and tell. *Mathematical Thinking and Learning*, 10(4), 313–340.
- Tabach, M., Levenson, E., Barkai, R., Tsamir, P., Tirosh, D., & Dreyfus, T. (2012). An organizer of mathematical statements for teachers: The six-cell matrix. *International Journal of Mathematical Education in Science and Technology*, 43(6), 765–777.
- Taras, M. (2005). Assessment–summative and formative–some theoretical reflections. *British Journal of Educational Studies*, 53(4), 466–478.
- Thomas, D., & Seely Brown, J. (2011). *A new culture of learning: Cultivating the imagination for a world of constant change*. CreateSpace Independent Publishing Platform.
- Tiede, J., & Grafe, S. (2018). *Triseum game-based learning validation study evaluation report – 2018*. European Schoolnet. [https://storage.eun.org/resources/upload/226/Triseum\\_Pilot\\_report-1.pdf](https://storage.eun.org/resources/upload/226/Triseum_Pilot_report-1.pdf)
- Trouche, L. (2004). Managing the complexity of human/machine interactions in computerized learning environments: Guiding students’ command process through instrumental orchestrations. *International Journal of Computers for Mathematical Learning*, 9(3), 281–307.

# Chapter 15

## A Trajectory of Digital Technologies Integration in Mathematical Education in Brazil: Challenges and Opportunities



Maria Elisabette Brisola Brito Prado, Nielce Meneguelo Lobo da Costa,  
and José Armando Valente

**Abstract** This chapter presents a trajectory of Digital Technologies in the teaching of Mathematics in Brazil, since 1980. Papert's ideas regarding constructionism arrived in the country in the 70 s, with the proposal of teaching the Logo Programming Language. From the beginning of the 1980s, there was great incentive and support from the Brazilian government for the development of several projects aimed mainly at K-12 Education. However, in Higher Education, digital technologies were used only in isolated subjects such as Calculus and Geometries, with innovation centred on integration of software, such as Cabri, Graphmatica and Winplot. Currently, the National Common Base Curriculum (BNCC) proposes the integration of technology into the K-12 curriculum. One possibility is the insertion of Programming, such as the use of Scratch, into the K-12 Mathematics curriculum, with the objective of promoting the development of computational thinking. These new norms have driven the curricular reformulation of undergraduate courses as well, opening up possibilities for increased integration of Programming activities designed according to the constructivist perspective effective in the teaching of mathematics concepts. Evidence demonstrates that creating computer programs and applying concepts and strategies facilitates the development of computational and mathematical thinking.

**Keywords** Constructionism · Programming language · Educational technologies · Computational thinking · Curriculum

---

M. E. B. B. Prado (✉) · N. M. L. da Costa  
Universidade Anhanguera de São Paulo UNIAN, São Paulo, Brazil  
e-mail: [bette.prado@gmail.com](mailto:bette.prado@gmail.com); [nielce.lobo@anhanguera.com](mailto:nielce.lobo@anhanguera.com)

J. A. Valente  
Universidade Estadual de Campinas – UNICAMP, Campinas, São Paulo, Brazil  
e-mail: [jvalente@unicamp.br](mailto:jvalente@unicamp.br)



## Introduction

In Brazil the integration of Digital Information and Communication Technologies (DICT) in teaching has been an ongoing effort for some time, marked by both challenges and opportunities. We can identify the beginning of a recent trajectory in this history with a meeting of prominent figures in the mid-1970s. This history at least as far back as the mid-1970s. The Director of the Institute of Mathematics, Statistics, and Computer Science at the State University of Campinas (UNICAMP), at that time, the great visionary Professor Ubiratan D'Ambrósio, invited two international researchers, Seymour Papert and Marvin Minsky from the Massachusetts Institute of Technology (MIT), to an extended residency at the university. These researchers were developing the computer language Logo, and discussed during their stay at the university innovative ideas on technological evolution, inspiring a group of teachers<sup>1</sup> to undertake an investigative look at the impacts that technologies could have on the cognitive development of Brazilian children and young students.

It is worth remembering that, in this period, the direct interaction between people and machines (computers) was still limited. Nevertheless, these teacher-researchers already visualized much greater interaction and increased possibilities for learning with computers. Papert's enthusiasm for the potential of children teaching the computer to solve problems, a provocative reversal of common sense thinking about learning (in which the computer would be teaching the children) (Papert & Solomon, 1971), led Brazilian educators to explore the richness of children learning programming languages. This early foray into children learning with computers found young learners using the Logo computer language via a terminal connected to a large, 'mainframe,' computer system, allowing the users to program the movements of a robot in real physical space. Later, with further technological development and the introduction of the Personal Computer (PC), the Logo language was incorporated directly on the computer screen; instead of commanding the robot, the user could command a graphic turtle-shaped cursor, and program its movement on the screen, that is, in the plane.

Logo was created as part of the activities of MIT's Artificial Intelligence Laboratory, and this involved the development of sophisticated features that allow it to perform activities in various areas such as graphics, music, symbolic processing, robotics, animation, and combinations of these areas (Valente, 2005, p. 50).

The interaction with these researchers from MIT with the Brazilian group during their residency instigated as well the development of research focused on understanding children's thinking. That is, the Brazilian researchers explored, for example, how the children used in their programming a finished mathematical concept in a formal or intuitive way to solve a problem when programming.

---

<sup>1</sup>Professors at UNICAMP such as Afira Ripper, Fernando Curado, José Armando Valente. Later, José A. Valente, supported by Prof. Ubiratan D'Ambrósio, conducted his doctoral study at MIT, under the guidance of Seymour Papert (Valente, 1983).

The child programs the computer. And in teaching the computer how to think, children embark on an exploration about how they themselves think. The experience can be heady: Thinking about thinking turns the child into an epistemologist, an experience not even shared by most adults (Papert, 1980, p. 19).

In this perspective, the computer was no longer merely an object of the learning environment; it was now conceived as taking on a facilitating role, supporting users (students and teachers) in assuming a posture of “the active builders of their own intellectual structures” (Papert, 1980, p. 19). Papert had emphasized how the programming activity made interaction with the computer attractive and interesting. Teaching the machine, that is, by building something meaningful to them so that they experience a creative and reflective process of learning, established the children as protagonists of their own learning.

These ideas spread in Brazil, from the first formal initiatives in 1981 (Valente & Almeida, 2020), throughout the ensuing 40 years, so that it is possible to identify a trajectory of the use of DICT in mathematics education evolving from Papert’s ideas and the use of Logo. This chapter describes this trajectory, and discusses the main milestones of DICT integration in Brazilian mathematics education. As the trajectory took its course, it is possible to note new software and systems beyond the Logo language, the refinement of theoretical constructs such as the constructionism proposed by Papert, transformations in the relationship between computational thinking and mathematics, toward the most recent proposal of the Common National Base Curriculum – BNCC for K-12 Education (Brazil, 2018), and finally, contemporary needs for the training of educators on the uses of DICT in the teaching of mathematics. The trajectory described here is based on experiences that the three authors have had as direct participants in the various research projects and the various educational actions since the beginning of this history. In this sense, the chapter is both a memoir and an analysis of this history, preserving our personal sense of the main events, but also critically reflecting on the choices and actions carried out throughout these past 40 years.

## **Brief Historical Overview of DICT Integration in Mathematics Teaching**

With the expansion of personal computer use in the early 1980s, the first initiatives to set up computer labs in public elementary schools were supported by the federal government in partnership with universities, as part of the EDUCOM Project (Andrade, 1993). This pilot research effort involved the participation of five universities, each developing a teaching methodology relying on the computer, preparing teachers for the new pedagogical practices that were possible with the computer, and carrying out research supporting the expansion of the new educational experiences. Two of these universities, the Laboratory of Cognitive Studies (LEC) at the Federal University of Rio Grande do Sul (UFRGS) and the Nucleus of Informatics Applied

to Education (NIED) at the State University of Campinas (UNICAMP), dedicated their research centres to the use of Logo (Valente & Almeida, 2020). The research focusing on the use of the Logo Language demonstrated positive and innovative outcomes, however, these occurred in specific situations and disconnected from classroom practices (Miskulin, 1993; Baranauskas, 1993a; Sidericoudes, 1996; Almeida, 2000; Prado & Valente, 2003). The research also revealed the teachers' difficulty in approaching curricular content, such as specific mathematical concepts embedded in the programming activity was also evidenced, indicating the need to rethink teacher training (Valente, 1996).

Furthermore, it was noted during the process of implementing the use of computers in schools that some teachers, in both K-12 and Higher Education, were uncomfortable and fearful, because they worried that the computer could replace their teaching role (Borba & Penteadó, 2007). This fear has contributed to developing in many educators an attitude contrary to the pedagogical use of computers at school. However, this impasse in the educational context was softened by the pronouncement of a great Brazilian educator, Paulo Freire. His words, spoken in various academic spaces, were vital in provoking university professors to reflect on new ways to comprehend this moment when computers started to arrive in public schools: "Preventing or hindering access of this technology to young students in public schools is an attitude that only reinforces a different kind of education to the oppressed social class" (Prado & Lobo da Costa, 2015, p. 252). Freire's thought aroused in several researchers, such as Castro (2011) and Vieira (2013), the interest in investigating how technology could be integrated into a teacher's practice as the teacher creates a learning environment, a shift from the previous attention to designing activities with the computer that did not involve teachers in ways other than as managers of the equipment. At this point, it became clear that the way forward was to invest in the continuing education of teachers.

Thus, by the 1990s, there was a large investment by agencies linked to the Ministry of Education in the dissemination of knowledge about the use of digital technologies in K-12 Education throughout all regions of the Brazilian territory. It was an intense job of continuing education for teachers and managers, enhanced as well by the availability of educational software beyond only the Logo programming language. For mathematics, Winplot, Graphmatica, and Cabri-Géomètre software stood out and became widely implemented in these dissemination efforts.

The Cabri-Géomètre software has had great acceptance and recognition by professionals in Mathematics Education in Brazil, due to its potential for assisting the teaching and learning of Geometry. This software was developed by Jean-Marie Laborde, Yves Baulac, and Franck Bellemain at the Laboratoire de Structures Discrètes et de Didactique of the Institut d'Informatique et de Mathématiques Appliquées of Grenoble, from 1984 to 1995, with the idea of being a 'rough book for geometry' that would facilitate exploration of the properties of and relations among geometric objects.<sup>2</sup> The software presents an interface with construction

---

<sup>2</sup>For more information see: <http://www.cabri.net/cabri2/historique-e.php>

menus in classic Geometry language. Geometric figures are constructed from their properties, so that when a user moves them in the plane they transform, maintaining the geometric relationships that characterize them. From 1992 on, the software became available for several countries in DOS and MacOS platforms, and, from 1995 on, a Windows version called Cabri-Géomètre II was released.

The Cabri-géomètre software was brought to Brazil by professors returning from doctoral studies abroad or working in French, English, and American research projects, and who, in partnership with foreign professors invited to join graduate programs in Mathematics Education,<sup>3</sup> started to develop their own research in Brazil. There have been several publications arising from these partnerships, such as, for example, Almouloud et al. (1998). Further research on the teaching of Geometry continued into the second half of the 1990s. Of particular note are research projects developed by the Graduate Program in Education at the Federal University of Ceará (UFC), in the state of Ceará, the Graduate Program in Mathematics Education at the Universidade Estadual Paulista “Júlio de Mesquita Filho” UNESP – Rio Claro campus and the Graduate Studies Program in Mathematics Education at the Pontifícia Universidade Católica de São Paulo (PUCSP), both in the state of São Paulo, and the Graduate Program in Education at the Universidade Federal do Paraná, in the state of Paraná. Pioneering research for teaching mathematics with the use of software beyond Geometry was conducted, for example, by: Sangiacomo (1996); Lobo da Costa (1997); Silva (1997); Campos (1999); Areas (1999); Henriques (1999); and da Purificação (1999). These studies presented didactic sequences to help with the teaching of Thales’ Theorem, symmetries and ornaments, quadrilaterals, metric geometry, trigonometry in triangle and cycle, in addition to the design of new materials for the teaching of Dynamic Geometry and the shift from drawing to figure and Cabri-Géomètre software as an epistemological adventure. Thus, by the end of the 1990s, in universities, and especially in graduate programs, this research movement on teaching geometry with the use of Cabri-Géomètre was firmly established.

However, the use of Cabri-Géomètre could not be expanded in K-12 Education with national coverage because it is proprietary software. This hinders its use in schools, and especially in public schools. Nevertheless, some innovative initiatives of DICT integration in teaching undertaken mainly by partnerships between State Education Departments and universities can be noted. One example is the 1997 PROCÍENCIAS project, a partnership between the State of São Paulo and universities, in which the Secretary of Education promoted continuing education projects for mathematics teachers aimed at integrating DICT into teaching, and particularly the Cabri-Géomètre software for teaching geometry. Yet it should be understood that the use of DICT had hardly reached a level of daily routine in Brazilian Mathematics classrooms until the end of the 1990s, except in a few elite private schools and some public schools in a few Brazilian states.

---

<sup>3</sup>Examples include: Saddo Ag. Almouloud, Lulu Healy, Sandra Magina, Ana Paula Jahn, Vincenzo Bongiovanni, Verônica Gitirana.

Significant in the expanding use of software for teaching mathematics was the development of GeoGebra software by Judith Hohenwarter and Markus Hohenwarter at the University of Salzburg in 2001 (Hohenwarter, 2002). This GPL (General Public License) software, written in Java language, runs on several platforms and presents, besides the interface with tools for plane geometry, the possibility of working with coordinates, equations, variables, roots, and functions, that is, with algebra, calculus, and analysis. GeoGebra heralded a genuine revolution, especially because the project continued to develop and, from version 5.0 on, because it became possible with GeoGebra 3D to work with spatial geometry.

By the early 2000's Brazilian Mathematics Education research had mostly moved over to the use of GeoGebra, thanks to its public license, its greater potential for mathematics learning beyond Geometry, and also because it has continued to evolve and find increased flexibility, offering possibilities for use, either online or offline, via computer, tablet, or smartphone. The flexibility, especially, has meant that the dissemination of GeoGebra in the educational context has been increasingly widespread and, with this expansion, research as well (Abar & dos Santos, 2021). Several groups<sup>4</sup> of mathematics educators from different public and private universities have been working both in continuing education projects for teachers of K-12 Education and in research on the teaching and learning of mathematics using GeoGebra.<sup>5</sup> These studies follow the technological evolution, as for example the mobile devices shown in Bairral's studies (2013), in which the use of the tablet and touchscreens brought a new option for user interaction with the object represented on the screen through touch. The different and simultaneous types of touches on the screen offer the user more dynamism and freedom of manipulation with the objects on the screen. (Bairral et al., 2015) Using touchscreen activities with the software Geometric Constructor, it became possible to study the development of geometric reasoning in high school students through the observation of students' interaction with the touchscreen, further highlighting the refinement of the trajectory away from experiments with the technology as the object, toward the thinking and cognitive changes in learners. Bairral concluded that it "[...] may bring new cognitive insights to mathematics education with this type of digital technology" (Bairral, 2013, p. 16).

Research results also point to innovative practices that encourage students in Elementary Education to engage with mathematical content, both in geometry and

---

<sup>4</sup>For example: Research Group on Informatics, Other Media and Mathematics Education (GPIMEM), coordinated by Professor Marcelo de Carvalho Borba, Universidade Estadual Paulista – UNESP/Rio Claro; GeoGebra Institute of São Paulo, coordinated by Professor Celina AAP Abar of the Pontifícia Universidade Católica de São Paulo (PUC/SP), which is part of the International GeoGebra Institute (IGI), among other groups of researchers belonging to universities in various regions of the country.

<sup>5</sup>The Catalog of Theses and Dissertations of CAPES (<https://catalogodeteses.capes.gov.br/catalogo-teses/#/>), in a survey made in November 2021, pointed to 1389 researches that resulted in Theses and Dissertations in Brazil, involving GeoGebra, in the period from 2008 to 2021. These scientific papers came from 152 Higher Education Institutions, with 762 different professors, which show the existence of a community of Brazilian researchers investigating the use of the software in teacher education and in the teaching and learning of mathematics.

the study of functions, through new ways of learning with touchscreen technology. Notably, the use of dynamic mathematics software developed in a pedagogical perspective in which the student assumes an active posture, made possible by allowing exploration, conjecture, and reflection on mathematical objects, has proven to be a viable way both to recover this learning and to deepen the understanding of geometry, algebra, calculus, and analysis. Indeed, it is now accepted by almost all mathematics educators in Brazil that both the use of educational software and a programming language are powerful technological resources; however, this is understood to depend on the pedagogical approach adopted by the teacher to enable students to experience new ways of learning geared toward the development of autonomy and their protagonism in the learning process.

Under this focus, we highlight Papert's conception that gave origin to the theoretical construct called constructionism, which guides the practices with the use of digital technologies to be developed in the school context.

## Constructionism: A Theoretical Construct

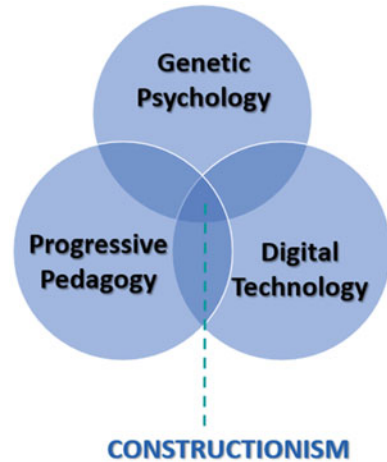
Papert coined the term "constructionism" as part of the proposal presented and funded by the National Science Foundation in 1986 (Papert, 1986). In this proposal, he stated that:

... learning is particularly effective when it is embedded in an activity the learner experiences as constructing a meaningful product (for example, a work of art, a functioning machine, a research report, or a computer program) (Papert, 1986, p. abstract).

Although constructionism emerged in the computational context, more specifically in the programming activity, the roots of this approach are based on the assumptions of Piaget's psychology and Dewey's developmental pedagogy. Within Piagetian psychology theory, constructionism inherited its main attribute from constructivism, as a process of construction and reconstruction of mental structures through the child's interaction with the world (Piaget, 1985). As for the pedagogical principles advocated by Dewey, we can highlight student-centred teaching, which emphasizes students' experience and learning-by-doing (Dewey, 1979), as illustrated in Fig. 15.1.

The constructionist approach, according to Papert (1990, 1994), Falbel (1993), Ackermann (1991), and Harel (1991), highlights the importance of developing materials and creating learning environments that allow learners to engage in construction and reflective activities. Under this approach, the materials should facilitate students in both learning-with and learning-about-thinking. The main idea is that hands-on and head-in experiences enable students to learn by doing (getting their hands dirty) and by building something that is meaningful to them, so that they become emotionally and cognitively involved with what is being produced. It is important that the product is something tangible and capable of being made and understood by the student-producer, something that allows them to recognize an

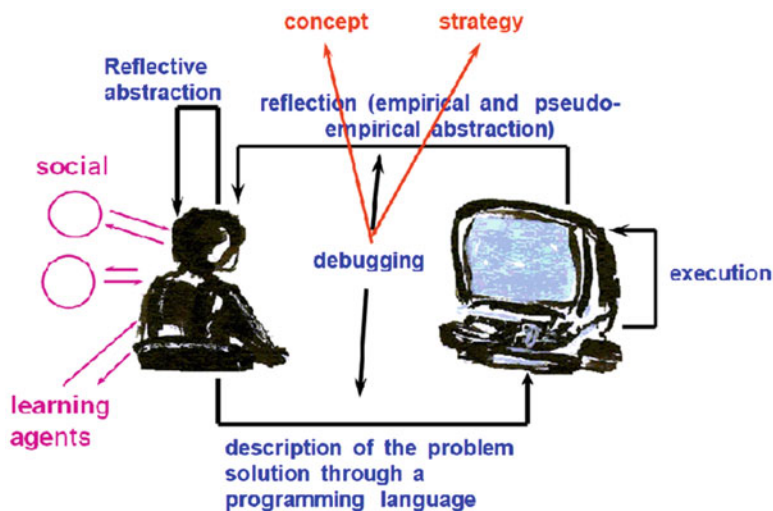
**Fig. 15.1** Theoretical construct of Constructionism. (Source: the authors)



immediate usefulness for what is being made during the production process and, especially, for what is being learned (Prado & Valente, 2003). When creating learning environments, it is necessary to consider, in addition to the materials, the choice of activities, the diversity of learning situations, and the quality of the interactions that are established in this context. Thus, a learning environment consisting of these characteristics presupposes the use of the computer as a medium that enables subjects to experience a reflective learning process.

Valente (2002) warns that an emphasis on the pedagogical use of technologies cannot be solely centred on technique but must also encompass the thought process involved in the activity of programming the computer. We extend this as well to the construction of mathematical objects with a touchscreen. Following Valente, we can elaborate on this thought process by specifying the constitutive elements of the cycle of actions that is established in the interaction of the subject with the computer during the programming activity, as illustrated in Fig. 15.2: *description – execution – reflection – debugging – (new) description*.

Figure 15.2 describes the interaction of the subject (the learner) with the computer, which begins when the subject elaborates the *description* of the solution to the problem for the computer. For this to take place, the subject needs to interpret the problem, and then write the algorithm based on formal or intuitive mathematical concepts, which are translated into computational language. Hence, in the description, concepts and strategies related to the problem and the computational environment are used. From this description, the computer carries out the immediate *execution* and shows on the computer screen the result that corresponds to the machine's feedback, and expresses for the subject what the subject had thought. In terms of learning, it is interesting when there is a confrontation between the result obtained and the expected one, because this situation can favour the occurrence of *reflection* by the subject about their own thinking regarding the concepts and strategies used to solve the problem. It is through this reflective process that the



**Fig. 15.2** Cycle of actions in the interaction between subject and computer in the programming situation. (Source: Adapted from Valente (2005))

subject is provoked to seek new understandings and to *debug* their ideas, reviewing their interpretation of the problem, as well as the concepts involved. From then on, the cycle of actions restarts at another level of understanding, revealed by a *new description*. Thus, a continuous iteration of cycles of actions and comprehension is established, with the presence of the learning agent (the computer) as mediator and the social context, configuring this process in a learning spiral.

The idea of a cycle conceived in the format of an ascending spiral, of continuous movements of actions-thoughts toward new understandings (Valente, 2005), is also represented in the interactionist theories formulated by authors such as Piaget (1985) and D'Ambrosio (1986), among others. Piaget used the assimilation-adaptation-accommodation cycle, which is set in the various levels of interaction of subjects with their environment, to explain the development of cognitive structures. For D'Ambrósio, intellectual evolution can be explained by the reality-reflection-action-reality cycle. In D'Ambrósio's cycle, the dialectical relationship between reflection and action in the learning process is established in the interaction of individuals with the social and cultural reality. In this interaction, individuals learn and modify reality, generating new artefacts that trigger new thought-action processes. And one of these artefacts is the computer, which is one of the key elements in the scenario of this study.

However, the cycle of actions that can occur when subjects interact with the computer does not always spontaneously, on its own, provoke the reflection process and conceptual systematization. This aspect is critically important in terms of technology use in the school context. Helpful for consideration of this important factor is the work of Valente (2002) and Prado and Valente (2003), which differentiates the nature of the feedback given by the computer and provided by the teacher-



mediator. Computer feedback is based on logic, proper to the computational language. Teacher-mediator feedback is human and is able to address the cognitive, affective, and social dimensions of the student, informed by the teacher's professional intentions for the activity and educational commitments. Given the strong presence of technologies in contemporary society and the need to prepare new generations for contemporary society, teacher education must be rethought, especially in terms of the demands made by the development of computational thinking.

## Computational Thinking and Mathematics

A growing movement of researchers and professionals in the fields of Education and Computing from the United States, Brazil, and several European countries have been discussing and designing strategies to insert actions that enable students in K-12 education to develop computational thinking. In Brazil, this movement coincided with the elaboration phase of the BNCC (Brazil, 2018), an official curriculum document listing the competencies that should be developed by students at all levels of schooling in K-12 Education. The BNCC provides guidelines marking the importance of Information and Communication Technologies and Digital Culture in Education.

[...]The digital culture has promoted significant social changes in contemporary societies. As a result of the advance and multiplication of information and communication technologies and the increasing access to them through the greater availability of computers, cell phones, tablets, and the like, students are dynamically inserted in this culture, not only as consumers. (Brazil, 2018, p. 61, emphasis added)

This means that it is the school's responsibility to fulfil its role in educating citizens prepared not only to be consumers of digital technologies, but also to be producers of new strategies to solve problems, as well as to provide the development of competencies related to mathematical literacy (reasoning, representation, communication, and argumentation) and computational thinking.

Valente (2016, 2019) claims that the computational thinking concept is still not well established, yet it is commonly understood among national and international researchers in similar and overlapping ways. For example, Wing (2006, p. 33) stresses that "computational thinking is a crucial skill for everyone, not just computer scientists," and adds that "computational thinking in the analytical skills of all children" should be included in addition to "reading, writing, and arithmetic. Brackmann (2017, p. 28) highlight some features of computational thinking that involve: "logical thinking, the ability to recognize patterns, reason through algorithms, and decomposing and abstracting a problem." These characteristics help the human being to develop skills.

Ramos and Espadeiro (2014, p. 2) list some of the analytical skills deemed crucial for computational thinking, namely: “recursive thinking, sequential and parallel thinking, abstraction, automation, decomposition, modelling, and simulation”.

The Computer Science Teachers Association (CSTA), in partnership with the International Society of Technology and Education (ISTE), has developed a definition of computational thinking grounded in problem solving, based on a survey of more than 700 teachers and researchers from around the world. By linking computational thinking to problem solving, this definition reduced the computer to a problem solving tool rather than an interactive element of a learning environment:

Formulating problems in a way that enables us to use a computer and other tools to help solve them; logically organizing and analyzing data; representing data through abstractions such as models and simulations; automating solutions through algorithmic thinking (a series of ordered steps); identifying, analyzing, and implementing possible solutions with the goal of achieving the most efficient and effective combination of steps and resources; generalizing and transferring this problem-solving process to a wide variety of problems (ISTE/CSTA, 2011, p. 7).

In contrast, the researcher Blikstein (2008) points out that computational thinking involves the use of the computer as a tool that extends human cognitive and operational power in ways that favour knowledge production and creativity. For Blikstein (2013), knowledge production is tied to the computer user and computational thinker as a maker of things valued in the world, for whom a tool is a resource for both accomplishing a task and for inventing new uses.

We can see that this current movement of stressing the importance of providing the development of computational thinking to students from K-12 Education onwards extends the early ideas of Papert (1980) and Harel (1991). Valente (2019, p. 5) recalls that “the term computational thinking had already been mentioned by Papert (1994, p. 184)” when pointing out that in programming activity with the Logo language, children could explore computational concepts through problem solving, which allowed them to develop logical thinking and mathematical ideas.

## **The Common National Base Curriculum (BNCC) and the Teaching of Mathematics**

The BNCC national document emphasizes the following for the Mathematics area:

Algorithmic language has common points with algebraic language, especially in relation to the concept of variable. Another skill related to algebra that maintains a close relationship with computational thinking is the identification of patterns to establish generalizations, properties, and algorithms (Brazil, 2018, p. 269).

For the authors Prado et al. (2020), the concept of variable and generalization is present in both algebraic and computational thinking. They highlight the studies of Blanton and Kaput (2005) on the centrality of generalization in algebraic thinking;

similarly, we consider that generalization plays a prominent role in computational thinking.

It is worth mentioning that high level programming languages are used in the context of K-12 education, i.e., with greater abstraction power and a syntax closer to natural languages. Among these languages, those that fit into the object-oriented computing paradigm, such as the Scratch programming language, are currently being used in the school context (Baranauskas, 1993b). The Scratch language was developed in 2007 by the Lifelong Kindergarten Group, a research consortium led by Mitchel Resnick and part of the Media Lab at the Massachusetts Institute of Technology – MIT, aiming to enable the participation of people of various ages, backgrounds, and nationalities in the creation of software such as games, animations, and simulations (Resnick et al., 2009). Resnick emphasizes that Scratch was not created with the intention of forming professional programmers, but so that people could express themselves creatively through computer programming.

A mathematics activity in which the student can create a program, even a simple one, such as teaching the computer to identify whether a given number is odd or even, may already be enough to provoke a feeling of empowerment in the student. That is, it can be enough that the learner recognizes that they themselves must already have the knowledge to teach the machine through programming, in order for the machine to learn.

[...] the constructions developed by the students show that Scratch enables the manipulation of concepts and symbols according to logical formal rules (propositional calculus), though these usually are implicit to the programmer. Therefore, the Scratch programming language, although it is similar to natural language, has a clear mathematical basis (Vecchia et al., 2015, p. 58).

Another context with great potential is robotics, in which students build concrete objects (machines that move), and through programming, define the behavior of these objects, i.e., the mechanism of their operation. This type of activity involves the integration of different areas of knowledge, such as Science, Technology, Engineering, and Mathematics (STEM) (Greca Dufranc et al., 2020).

Looking at the scenario of digital technology in education and its trajectory, it is evident in research that a gap remains between the technological innovations that are within the reach of this current generation of students and the practices that occur in the context of K-12 education. The several initiatives and actions that have taken place from 1985 to the present day regarding the continuing education of teachers on the use of digital technologies (programming, robotics, educational software, games, etc.), and on the integration of technologies within curricular contents, appear from the vantage point of the present day to be extremely limited in scope and vision. Research demonstrates that practices using digital technologies often occur as an appendix to classroom work, indicating that the challenge to provide an effective and integrated use of technologies in the school context continues (Almeida & Valente, 2011). Technology is often inserted into school practice, that is, “[...] teachers use it, but without this causing a different learning from what was done before and, more than that, the computer becomes a strange instrument (alien) to the pedagogical

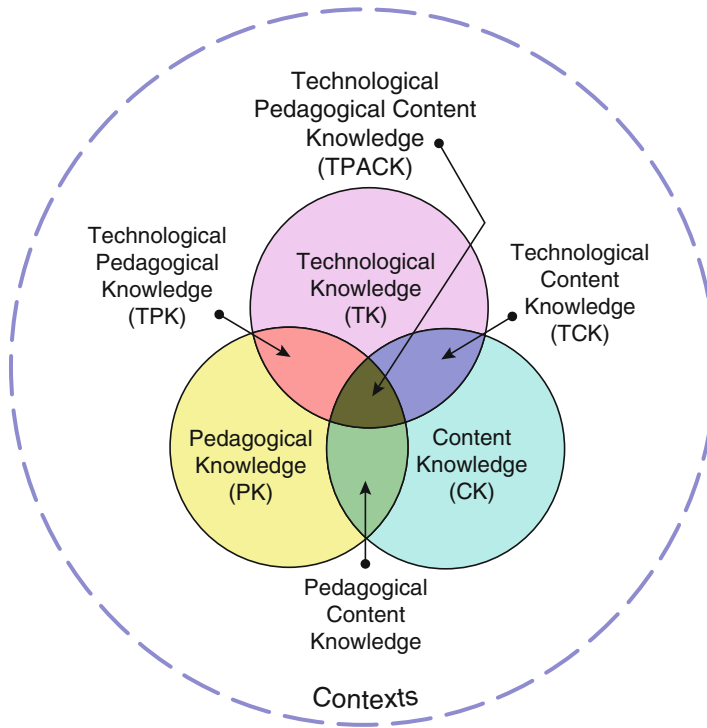
practice” (Bittar, 2010, p. 259). As Bittar notes, the insertion of technology in education differs from the integration of the use of a certain software, and the teacher’s intention to provide the student with a new way of learning the curricular content. We understand that this occurs for several reasons. One is the structure and organization of the school system, which mirrors the paradigm of the last century. Another reason is that the university courses that prepare teachers do not fully contemplate the real demand to be able to practice a pedagogy that integrates the technological resources. Given this situation, the emphasis has remained focused on remediating a lack of preparation through the continuing education of teachers.

## The Teacher Education and Professional Knowledge

As discussed above, the continuing education of teachers on the use of digital technologies throughout the trajectory explored in this chapter has been led by initiatives of courses linked to the Ministry of Education and the State and Municipal Education Departments in partnership with public and private universities. Generally, these courses were primarily about technical content related to software, applications, and programming languages, and, in some of them, theories related to pedagogical approaches that could guide the practices to be developed in the context of K-12 education were also emphasized. There was undoubtedly the need for the teachers participating in the courses to appropriate the operational aspects of the technological resources, which took more time, because according to them, the process of technological appropriation does not occur immediately, but rather in phases that normally evolve in the sense of learning how to make pedagogical use of the technology (Sandholtz et al., 1997; Almeida & Valente, 2011; Vieira & Lobo da Costa, 2016).

This “learning to do” requires the reconstruction of the teacher’s professional knowledge, as pointed out by Mishra and Koehler (2006). These researchers created a model called TPACK – Technological Pedagogical Content Knowledge, based on Shulman’s Knowledge Based Theory (Shulman, 1986), which is constituted by the integration of Pedagogical Knowledge (PK) and Content Knowledge (CK). Mishra and Koehler integrated Technological Knowledge (TK) within this structure, as shown in Fig. 15.3.

The constitution of TPACK, as indicated in Fig. 15.3, develops through three intersections, involving Pedagogical, Technological, and Content-specific knowledge. The intersection between pedagogy and content knowledge results in Pedagogical Content Knowledge (PCK), inherited from the ideas of Shulman (1986, 1987), and refers to the teacher’s knowledge of which pedagogical approaches are appropriate for teaching given content objectives. In the context of teaching mathematics, this type of knowledge has been widely discussed in research based on the ideas of Ball et al. (2008), who emphasize the importance of the teacher’s specialized knowledge for mathematics teaching. For Ball and her collaborators, this mathematical knowledge for teaching is not limited to the common knowledge of



**Fig. 15.3** Technological Pedagogical Content Knowledge. (Source: The TPACK framework and its knowledge components (Koehler & Mishra, 2009, p. 63))

mathematical content, but adds knowledge that the teacher must have about what makes some mathematical concepts and procedures difficult to teach and/or learn, and also how to help students to overcome the difficulties, the epistemological obstacles and the most common mistakes. The intersection of content and technology derives from Technological Content Knowledge (TCK), which refers to the understanding of the reciprocal relationships between technology and content. The technology both restricts some types of representations and presents new and varied possibilities of representations, and creates greater flexibility of conversions among them. Therefore, it is necessary for teachers to know, in addition to the subject matter they teach, in our case mathematics, the ways in which the use of technology changes their approach. This type of integration – technology and content -, when using specific software, has been happening more naturally, as it allows the teacher and the student to explore new ways of representing knowledge and deepening the understanding of mathematical concepts.

However, the intersection of pedagogy and technology generates Technological Pedagogical Knowledge (TPK – Technological Pedagogical Knowledge), which refers to knowing the potential of different technological resources and their implications for teaching and learning processes. This knowledge intersection has been

more challenging for teachers to develop, because their understanding of teaching practices is still often guided by conceptions that differ from the constructionist view. This intersection, even more than the others, requires a conception of the learning environment as prioritizing situations in which the student can *learn-with* and *learn-about-thinking* (Resnick et al., 2009). This idea of a pedagogy focused on active learning, promoting the student as protagonist developing their autonomy and creativity, was strongly promoted by Papert in creating a constructionist approach – even before his residency in Brazil in 1980. The notion is even more important today, considering advances in technology and the characteristics of today’s society, which require not only an individual who consumes technology, but also producers of new solutions, both local and global.

Finally, the intersections that result in the three types of knowledge (PCK, TPK, and TCK) originates TPACK, which symbolizes an emergent form of knowledge that goes beyond all its components (content [in our case mathematics], pedagogy, and technology). This is the type of knowledge to be mobilized for teaching with technology situated in each context. Indeed, research such as that of Lobo da Costa and Prado (2015), Colling and Richit (2019), Rocha et al. (2020) shows that using technology to teach mathematics to meet the specificities of each mathematics subfield (numerical, algebraic, geometric, etc.) must consider the precise educational context of performance, and allow students to build mathematical knowledge. This is a challenge that, to be met, depends on the teacher experiencing a gradual process of knowledge appropriation and reconstruction from the TPACK perspective. Hence the importance of rethinking the continuing and initial education courses for teachers who teach mathematics, considering that this learning itself can also occur based on the principles of learning-by-doing and reflecting on a new way of teaching mathematics by integrating technology into the curriculum.

## Final Considerations

In the process of revisiting and reflecting on the challenges and possibilities in the trajectory of DICT integration in teaching and learning mathematics, our view as researchers who participated in the main projects and formative actions since the beginning of this path was focused on recovering ideas from the past. We identified the principle of constructionism as a primary motivator for the integration of educational technologies, consistent throughout the trajectory and currently present in active teaching methodologies and computational thinking. We returned to the 1980s and to the origins of the insertion of digital technologies into Education in Brazil, with the Logo Programming Language, and particularly, in Mathematics teaching with Winplot and Graphmatica software used mainly in Higher Education, specifically in the subdisciplines of Calculus and Analysis. The Cabri-géomètre software facilitated the spread of DICT in graduate courses and research, having planted the seed for a culture of using Dynamic Geometry for teaching. The emergence of GeoGebra, disseminated with great emphasis since 2005, started to

be used in most studies and research in Mathematics Education, especially in geometry, algebra, and analysis. With GeoGebra, “Dynamic Mathematics” has begun to reach the classroom, including the study of spatial geometry, with the GeoGebra 3D version, and most recently with the potentialities of GeoGebra AR.

The development of DICT and their dissemination allowed us to glimpse and create possibilities for change in the teaching and learning processes in the context of K-12 education, especially in the sense of reconstruction of pedagogical practices. An example of such reconstructions is the official document of the National Common Base Curriculum, which proposes the integration of technology into the K-12 curriculum. The BNCC has created the possibility of inserting Programming, such as the use of Scratch, into the K-12 Mathematics curriculum, in order to promote computational thinking. The integration of DICT activities and the K-12 Mathematics curriculum has also promoted the curricular reformulation of undergraduate courses, which may lead Programming activities to become effective in the teaching of mathematical concepts according to the constructionist perspective. Likewise, the proposals for continued teacher training based on the official document of the BNCC have been directed towards providing teachers with the reconstruction of knowledge from the perspective of TPACK, the technological pedagogical content knowledge. Moreover, there is a movement towards providing students at different levels of education with a creative and collaborative way of learning, in which they seek to solve real world problems, assuming authorship in the production of ideas and the construction of knowledge. Of particular current interest is the transformation of activities with the advent of touchscreens on mobile devices. It is expected that the trajectory will continue, probably with faster actions and reconstructions, consistent with the ongoing technological evolution, which should also provide for the evolution of human intelligence.

## References

- Abar, C. A. A., & Dos Santos, J. M. (2021). Mapeamento dos artigos publicados na Revista do Instituto GeoGebra Internacional de São Paulo entre 2013 e 2018. *Revista de Matemática, Ensino e Cultura*, 16(37), 01–13.
- Ackermann, E. (1991). From Decontextualized to situated knowledge: Revising Piaget’s water-level experiment. Epistemology and learning group. In I. Harel & S. Papert (Eds.), *Construcionism* (pp. 269–294). Ablex Publishing Corporation.
- Almeida, M. E. B. (2000). *O computador na escola: contextualizando a formação de professores*. Dissertation, Doctor in Education, São Paulo: Programa de Pós-Graduação em Educação: Currículo, Pontifícia Universidade Católica de São Paulo.
- Almeida, M. E. B., & Valente, J. A. (2011). *Tecnologias e Currículo: trajetórias convergentes ou divergentes?* Paulus.
- Almouloud, S. A., Bongiovanni, V., & Campos, T. (1998). Les coniques: Construction d’une séquence didactique avec Cabri-Géomètre. *Scientia Paedagogica Experimentalis*, 35(1), 119–159.
- Andrade, P. F. (1993). (org.) *Projeto EDUCOM: realizações e produtos*. Ministério da Educação e Organização dos Estados Americanos.

- Areas, E. das N. (1999). *Sobre Simetrias e Ornamentos*. Thesis, Master in Mathematics. Universidade Estadual de Campinas – UNICAMP.
- Bairral, M. A. (2013). Do clique ao touchscreen: novas formas de interação e de aprendizado matemático. *Anais 36ª Reunião Nacional da ANPED*, Goiânia.
- Bairral, M. A., Arzarello, F., & de Assis, A. R. (2015). High School students rotating shapes in GeoGebra with touchscreen. *Quaderni di Ricerca in Didattica*, 25, 103–108.
- Ball, D. L., Thames, M. H., & Phelps, G. (2008). Content knowledge for teaching: What makes it special? *Journal of Teacher Education*, 59(5), 389–407.
- Baranauskas, M. C. C. (1993a). Uma abordagem Construcionista ao Design de um Ambiente para Programação em Lógica. In J. A. Valente (org.). *Computadores e conhecimento: repensando a educação* (pp. 313–330). UNICAMP/NIED.
- Baranauskas, M. C. C. (1993b). Procedimento, função, objeto ou lógica? Linguagens de programação vistas pelos seus paradigmas. In J. A. Valente (org.). *Computadores e Conhecimento: repensando a educação* (pp. 55–76). UNICAMP/NIED.
- Bittar, M. (2010). A Incorporação de um Software em uma Sala de Matemática: uma análise segundo a abordagem instrumental. In A. P. Jahn & N. S. G. Allevato (Org.). *Tecnologias e Educação Matemática: ensino, aprendizagem e formação de professores* (1ªed, Vol. 7, p. 209–225). SBEM.
- Blanton, M., & Kaput, J. (2005). Characterizing a classroom practice that promotes algebraic reasoning. *Journal for Research in Mathematics Education*, 36(5), 412–446.
- Blikstein, P. (2008). *O pensamento computacional e a reinvenção do computador na educação*. [http://www.blikstein.com/paulo/documents/online/ol\\_pensamento\\_computacional.html](http://www.blikstein.com/paulo/documents/online/ol_pensamento_computacional.html).
- Blikstein, P. (2013). Digital fabrication and “making” in education: The democratization of invention. In J. Walter-Herrmann & C. Büching (Eds.), *FabLabs: Of machines, makers and inventors* (pp. 1–21). Transcript Publishers.
- Borba, M. d. C., & Penteadó, M. G. (2007). *Informática e Educação Matemática (5ª edição)*. Autêntica.
- Brackmann, C. P. (2017). *Desenvolvimento do pensamento computacional através de atividades desplugadas na educação básica*. Dissertation, Doctor in Informatics in Education. Universidade Federal do Rio Grande do Sul.
- Brasil. (2018). *Base Nacional Comum Curricular – BNCC*. Ministério da Educação.
- Campos, M. O. C. (1999). *Cabri-Géomètre: uma aventura epistemológica*. Thesis. Master in Education. Universidade Federal do Ceará – UFCE.
- Castro, A. L. (2011). *Tecnologias Digitais de Informação e Comunicação e o Ensino de Funções Quadráticas: contribuições para a compreensão das diferentes representações*. Dissertação (Educação Matemática). Universidade Bandeirante de São Paulo.
- Colling, J., & Richit, A. (2019). Conhecimentos Pedagógico, Tecnológico e do Conteúdo na Formação Inicial do Professor de Matemática. *Educação Matemática Pesquisa*, 21(2), 394–421.
- D’Ambrosio, U. (1986). *Da realidade à ação: reflexões sobre Educação e Matemática*. Summus.
- Purificação, I. C. da. (1999). *Cabri-Géomètre e Teoria Van Hiele: possibilidades e avanços na construção do conceito de quadrilátero*. Thesis, Master in Education. Universidade Federal do Paraná – UFPR.
- Dewey, J. (1979). *Como pensamos – como se relaciona o pensamento reflexivo com o processo educativo: uma reexposição*. Editora Nacional.
- Falbel, A. (1993). *What is Construcionism? LEGO Publication*.
- Greca Dufranc, I. M., García Terceño, E. M., Fridberg, M., Cronquist, B., & Redfors, A. (2020). Robotics and early-years STEM education: The botSTEM framework and activities. *European Journal of STEM Education*, 5(1), 1. <https://doi.org/10.20897/ejsteme/7948>
- Harel, I. (1991). *Children designers*. Ablex Publishing Corporation.
- Henriques, A. (1999). *Ensino e Aprendizagem da Geometria Métrica: uma sequência didática com auxílio do software Cabri-Geometre*. Thesis. Master in Mathematic Education. Universidade Paulista de São Paulo.



- Hohenwarter, M. (2002). *Introduzione a GeoGebra*. Trad. Simona Riva. <https://sodilinux.itd.cnr.it/sdl6x2/documentazione/geogebra/intro-it.pdf>
- ISTE/CSTA (2011). *Computational Thinking Teacher Resource* (2ª edição). Computer Science Teachers Association (CSTA) and the International Society for Technology in Education (ISTE). [https://csta.acm.org/Curriculum/sub/CurrFiles/472.11CTTeacherResources\\_2ed-SP-vF.pdf](https://csta.acm.org/Curriculum/sub/CurrFiles/472.11CTTeacherResources_2ed-SP-vF.pdf).
- Koehler, M. J., & Mishra, P. (2009). What is technological pedagogical content knowledge? *Contemporary Issues in Technology and Teacher Education*, 9(1), 60–70.
- Lobo da Costa, N. M. (1997). *Funções Seno e Cosseno: Uma Sequência de Ensino a partir dos Contextos do 'Mundo Experimental' e do Computador*. Thesis, Master in Mathematic Education. Pontifícia Universidade Católica de São Paulo – PUCSP.
- Lobo da Costa, N. M., & Prado, M. E. B. B. (2015). A integração das tecnologias digitais ao ensino de Matemática: desafio constante no cotidiano escolar do professor. *Perspectivas da Educação Matemática*, 8(16), 99–119.
- Mishra, P., & Koehler, M. J. (2006). Technological pedagogical content knowledge: A framework for teacher knowledge. *Teachers College Record*, 108(6), 1017–1054.
- Miskulin, R. G. S. (1993). A importância da Heurística no processo de construção de Noções Geométricas em Ambientes Informatizados. In J. A. Valente (org.). *Computadores e conhecimento: repensando a educação* (pp. 208–233). UNICAMP/NIED.
- Papert, S. (1980). *Mindstorms: Children, computers, and powerful ideas*. Basic Books.
- Papert, S. (1986). *Constructionism: A new opportunity for elementary science education*. A proposal to the National Science Foundation, Massachusetts Institute of Technology, Media Laboratory, Epistemology and Learning Group.
- Papert, S. (1990). *Computer criticism vs technocentrism* (E&L Memo nº 01). Massachusetts Institute of Technology. Media Laboratory.
- Papert, S. (1994). *A máquina das crianças: repensando a escola na era da informática*. Artes Médicas.
- Papert, S. & Solomon, C. (1971). *Twenty things to do with a computer* (Logo Memo Nº 3). <http://www.stager.org/articles/twentythings.pdf>.
- Piaget, J. (1985). *Equilibration of cognitive structures*. University of Chicago Press.
- Prado, M. E. B. B., & Lobo da Costa, M. N. (2015). Educational laptop computers integrated into mathematics classrooms. In U. Gellert, J. Giménez Rodriguez, C. Hahn, & S. Kafoussi (Eds.), *Educational paths to mathematics: A C.I.E.A.E.M sourcebook* (pp. 351–365). Springer.
- Prado, M. E. B. B., & Valente, J. A. (2003). A formação na ação do professor: Uma abordagem na e para uma nova prática pedagógica. In J. A. Valente (Ed.), *Formação de educadores para o uso da Informática na escola* (pp. 21–38). Campinas, SP. <https://www.nied.unicamp.br/biblioteca/formacao-de-educadores-para-o-uso-da-informatica-na-escola/>
- Prado, M. E. B. B., Garcia Silva, A. F., Pietropaolo, R. C., & Silva, S. F. K. (2020). Pensamento Computacional e atividade de programação: perspectivas para o ensino da matemática. *Revista Sergipana de Matemática e Educação Matemática*, 5(2), 145–208.
- Ramos, J. L., & Espadeiro, R. G. (2014). Os futuros professores e os professores do futuro. Os desafios da introdução ao pensamento computacional na escola, no currículo e na aprendizagem. *Educação, Formação & Tecnologias*, 7(2), 4–25.
- Resnick, M., et al. (2009). Scratch: Programming for all. *Communications of the ACM*, 52(11), 60–67.
- Rocha, A. K. d. O., Prado, M. E. B. B., & Valente, J. A. (2020). A linguagem de programação Scratch na formação do professor: uma abordagem baseada no TPACK. *Revista Sergipana de Matemática e Educação Matemática*, 5(2), 19–36.
- Sandholtz, J. H., Ringstaff, C., & Dwyer, D. C. (1997). *Ensinando com Tecnologia: criando salas de aula centradas no aluno*. Artes Médicas.
- Sangiacomo, L. (1996). *O Processo da Mudança de Estatuto: de desenho para figura geométrica*. Thesis, Master in Mathematic Teaching. Pontifícia Universidade Católica de São Paulo – PUCSP.

- Shulman, L. S. (1986). Those who understand: Knowledge growth in teaching. *Educational Researcher*, 15(2), 4–14.
- Shulman, L. S. (1987). Knowledge and teaching: Foundations of the new reform. *Harvard Educational Review*, 57(1), 1–23.
- Sidericoudes, O. (1996). *Desenvolvimento de Metodologias de Ensino-Aprendizagem da Matemática em Ambientes Computacionais Baseados na Estética Logo*. Thesis, Master in Mathematic Education. Universidade Paulista de São Paulo – UNESP/Rio Claro.
- Silva, M. C. (1997). *Teorema de Thales: Uma Engenharia Didática utilizando o Cabri Geometre*. Thesis, Master in Mathematic Teaching. Pontifícia Universidade Católica de São Paulo – PUCSP.
- Valente, J. A. (1983). *Creating a computer-based learning environment for physically Handicapped children*. Dissertation, Doctor in Bioengineering and Education. Massachusetts Institute of Technology.
- Valente, J. A. (1996). (Org.) *O professor no ambiente Logo: Formação e atuação*. UNICAMP/ NIED.
- Valente, J. A. (2002). A espiral da aprendizagem e as tecnologias da informação e comunicação: repensando conceitos. In M. C. R. A. Joly (Ed.), *A tecnologia no ensino: implicações para a aprendizagem* (pp. 15–37). Casa do Psicólogo.
- Valente, J. A. (2005). *A espiral da espiral de aprendizagem: o processo de compreensão do papel das tecnologias de informação e comunicação na educação*. Dissertation, Full Professor. Universidade Estadual de Campinas – UNICAMP.
- Valente, J. A. (2016). Integração do pensamento computacional no currículo da educação básica: diferentes estratégias usadas e questões de formação de professores e avaliação do aluno. *Revista eCurriculum*, 14(3), 864–897.
- Valente, J. A. (2019). Pensamento computacional, letramento computacional ou competência digital? Novos desafios da educação. *Revista Educação e Cultura Contemporânea*, 16(43), 147–168.
- Valente, J. A., & Almeida, M. E. B. (2020). Brazilian technology policies in education: History and lessons learned. *Arquivos Analíticos de Políticas Educativas*, 28(94). <https://doi.org/10.14507/epaa.28.4295>
- Vecchia, R. D., Maltempi, M. V., & Borba, M. C. (2015). The construction of electronic games as an environment for mathematics education. In Lowrie, T. & Jorgensen (ZEVENBERGEN), R. (Eds.). *Mathematics education in the digital era* (pp. 55–70). Springer.
- Vieira, E. R. (2013). *Grupo de Estudos de professores e a apropriação de tecnologia digital no ensino de geometria: caminhos para o conhecimento profissional*. Tese (Educação Matemática). Universidade Bandeirante de São Paulo.
- Vieira, E. R., & Lobo da Costa, N. M. (2016). O processo de apropriação de tecnologias digitais por professores dos anos iniciais para o ensino de Geometria. *Perspectivas da Educação Matemática*, 9, 765–785.
- Wing, J. M. (2006). Computational thinking. *Communications of the ACM*, 49(3), 33–35.

# Chapter 16

## History, Technology and Dynamic Geometry: From Resources with Static Construction to DGE with Touchscreen



Marcelo Bairral

**Abstract** In the evolution of humanity Mathematics and Technology walk together in History. Changes in Mathematics affect Technology, and vice-versa. In this chapter, I make (Throughout the chapter I'll use I to emphasise my ideas and we when I'll invite the reader to think together about it.) a foray into the history of the production of some resources aimed at mathematics teaching and learning. I reflect about constraints or affordances of some resources, and I provide examples that claim for changes in mathematics and the school curriculum nowadays. I dedicate part of the end of the chapter to recent contributions from a research project on learning parallel lines intersected by a transversal line using GeoGebra on smartphones. I support the view that the use of dynamic geometric environments with touchscreens (DGEwT) in teaching parallel lines intersected by a transversal has revealed the importance of another concept, that of *reference*. I conclude with some pedagogical reflections.

**Keywords** Mathematical resources · Dynamic geometry · Touchscreen · Mobile devices

### Introduction

Mathematics and technology walk hand in hand and feed each other back on human evolution. Unfortunately, changes in mathematics and their history do not always arrive fast enough to the school curricula. Nevertheless, the demands for technological and innovation are always welcome by curricula developers, as we see, for instance, in STEM.<sup>1</sup>

---

<sup>1</sup>Science, Technology, Engineering and Mathematics (STEM).

M. Bairral (✉)  
Federal Rural University of Rio de Janeiro, Seropédica, Brazil  
e-mail: [mbairral@ufrj.br](mailto:mbairral@ufrj.br); <http://www.gepeticem.ufrj.br>

A great number of people do not perceive the changes in mathematics in their daily activities. Even when they have access to digital technologies (electronic card for transportation, GPS, online games, smartphones, streaming platforms etc.), many people do not see mathematics as a living science in constant transformation and recreation. This has been a great challenge for mathematics educators!

In this chapter,<sup>2</sup> I make a foray through the history of didactic resources devoted to teaching and learning mathematics. It is not an exhaustive or chronological reflection, and it can orient professional development actions aiming to improve teachers' mathematic knowledge for teaching (Ball et al., 2008).

One part of the chapter is dedicated to digital Dynamic Geometry Environments (DGE), which have introduced innovation alternatives, changes, and challenges into classrooms and into mathematics learning and research (King & Schattschneider, 1997). Mobile devices with touchscreen (MDwT), as tablets or smartphones, for instance, increasingly present in classrooms, are becoming more and more indispensable personal objects for students and even teachers. Particularly, the use of smartphones proved stimulating, as it allowed students to watch a set of elements (angles, line position, etc.) articulated with the handling of the drawn straight lines intersected by a transversal line with GeoGebra on smartphone. Teaching and learning parallel lines intersected by a transversal within this scenario of simultaneous movements and objects has brought out another concept, that of reference: Which pair of straight lines should be considered? Which angles? In addition to paying greater attention to the concept of reference, results also claim for less focus on memorizing names (corresponding angles, opposite by vertex etc.) in favour of a deeper understanding on angle properties and relations among them.

## Didactic Resources<sup>3</sup> and the Search for Mathematical Innovation

When reaching into the history of the production of manipulating material aimed to help with mathematics learning (golden bead material, Cuisenaire rods, logic blocs, etc.) it is possible, at least in Brazil, to see that these resources prioritized elementary arithmetic, and were primarily designed for the beginning years of schooling. Still, we know that it is possible to use the same materials in other school years, approaching different aspects of the same mathematics concepts.

Geoboards and puzzles (like Tangrams), among other resources, signal a new exploratory field focusing on geometrical relationships, in particular, important conceptual aspects like (de)composing, study and analysing areas without formulae, identification of (in)variables, exploration of varied and unusual shapes (like squares

---

<sup>2</sup>Product of a research project supported by CNPq and Faperj (Brazil).

<sup>3</sup>I am referring to the material resources specifically made for mathematics classes. I suggest Adler (2000) for an interesting conceptualization of resources.

and triangles), and the use of pieces as units of measurement and the establishment of other numerical relationships, etc. Each of these explorations focuses on geometric visualizing, and fosters among other contributions, the disengagement of teaching surface and perimeter as a common curricular unit. These concepts do not need to be taught together, because they are independent. Surface is measure of space (area) and perimeter is linear (longitude) measure. Teaching these concepts at same time could complicate understanding of each one.

In the simple historic retrospect that I engage in, I note that resources like the ones used for drawing (ruler, compass, protractor, etc.) heavily influenced curriculum development and pedagogy. In the case of geometric constructions, the tools were mostly geared towards procedures to perform certain constructions and in a perspective that limited movements. Although construction of a figure on paper (or folding) mobilizes a dynamic thought and action of gestures and motion – important for learning – the final, generated shapes seem to become the main focus of instruction. Because they restricted themselves to the construction of static shapes, motions and other semiotic resources (Bussi & Mariotti, 2008) tended to be out of the teacher's view. In other words, the procedures of construction and the constructed object were collapsed into a single aim.

Besides widening the possibilities for manipulation of the pieces, jigsaw puzzles, for example, are as easily generated with geometric constructions, and these constructions would be very fruitful for learning. We can use the concepts of bisector, perpendicular, midpoint, etc., and generate a puzzle by folding paper or using a ruler, a compass, etc.; these are situations that rescue and value geometric constructions, and do so with a purpose that is not merely procedural.

By the way of geometric constructions, museums *Museo Universitario di Storia Naturale website and the Strumentazione Scientifica Università degli studi di Modena e Reggio Emilia*<sup>4</sup> make available some applications that can move, rotate, deform, link, and otherwise relate elements that can become relevant tools for the teaching and learning of geometry.

There is a set of pantographs that provide dynamic movements and experiences in visualizing geometric constructions and concepts. Before computer graphics, the graphic representation of maps was not a simple task.

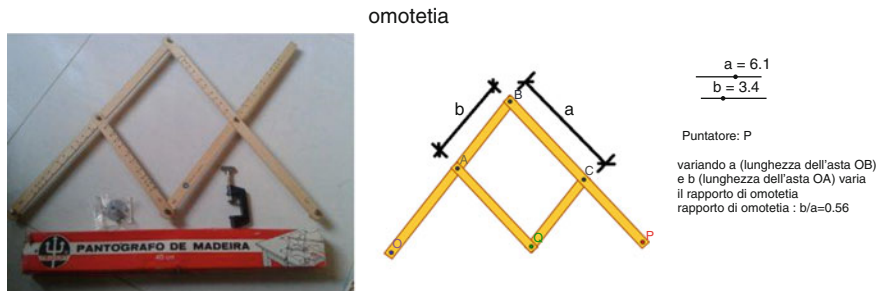
The complexity of contour lines of the regions that were represented at different scales required an instrument that would respect the sinuosity of the lines while keeping the scale of the map. Scheiner's pantograph (Fig. 16.1), also known as homothetic<sup>5</sup> pantograph, answered those needs.<sup>6</sup>

With the advancement of research in mathematics education, it became more evident that different resources contribute differently to our learning. No resource is

<sup>4</sup><http://www.mmmlab.unimore.it/site/home.html> Access: Aug. 10, 2020.

<sup>5</sup>Homothety is the transformation that links two by two the points on a plane, so that pairs of corresponding points are aligned with a fixed point and the ratio of the distances from this fixed point to the pairs of corresponding points is constant.

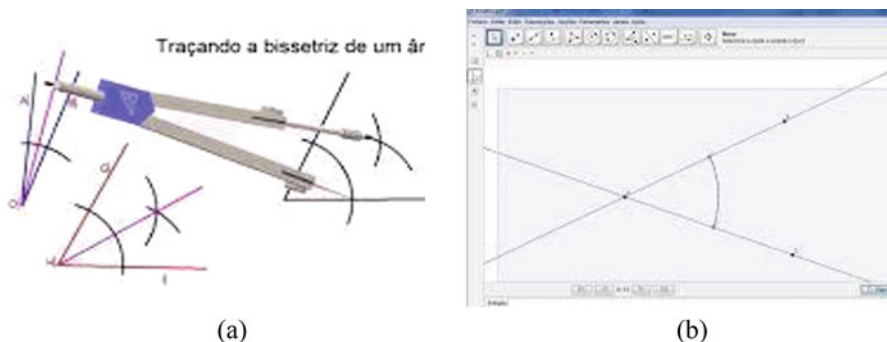
<sup>6</sup>See in Izar (2016) some interesting guides for the exploration of pantographs at the Museum.



**Fig. 16.1** Actual wooden and virtual Schneider’s Pantographs for amplified and reduced copies. (Sources: <http://img.olx.com.br/images/68/688529102427803.jpg>. <http://www.macchinematematiche.org/images/macchine/trasformazioni/simulazioni/omotetia.html>)

completely sufficient and, in accordance with the purpose of the teacher, it can be used in different school years. Moreover, as we interact with them, we follow procedures or concepts already existing, or we generate others, without necessarily building a hierarchy among concepts, procedures, etc. Instead of building any given hierarchy, we will always have cognitive movements and connections being made in fields both mathematical and extra-mathematical (Noss et al., 1997). For example, although the compass and the protractor have been part of student life for many of us who were in school before the advent of computers, we currently have other ways to do constructions, and measurements of angles and other mathematic objects. One of them is the digital geometry environment GeoGebra. As with all technology, the novelty of a mobile device brings light, but it also generates shadows, silhouetting us in different times and spaces, which are unique and complex.

Using a traditional compass to construct the bisector, it is necessary to mark different points using the same compass opening (one point within each line/angle side and, through each one, find the intersection point as shown in Fig. 16.2a, which generate the bisector). Using a Digital Geometry Environment (DGE) the subject only needs to use the angle bisector icon. Another example: using compass to find the orthocentre of a triangle it is necessary to localize three specific points, but in a DGE, only the construction of two points is necessary and sufficient. After the localization of the two points, you select “intersect the lines” and you will find the orthocentre. Have you asked yourself why? One more challenge: try to construct a square using ruler, compass and protractor, and afterword using a DGE. Did you find some constraints or affordances in each approach? Understanding and problematizing what lays behind a particular need (or lack of need) in the construction is important, especially in teacher training. For those who have themselves studied with the traditional, non-digital tool, this question makes sense. However, it does not make any sense for someone who has never learned with, or has never known those conventional drawing resources. Oh, yes! What we did with those traditional resources was a drawing; we used to create a single image. With DGEs we build a class of figures.



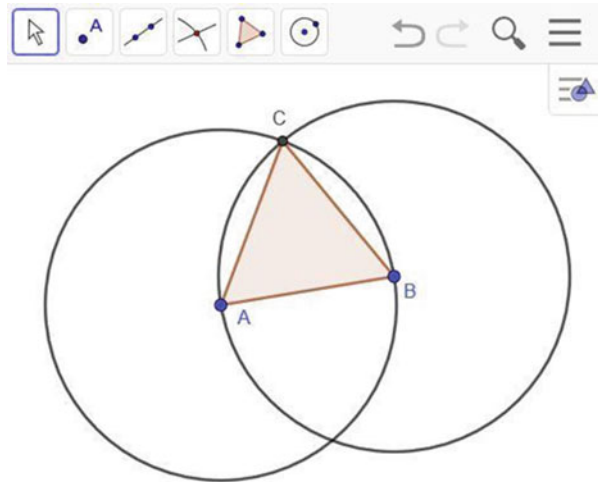
**Fig. 16.2** Building a bisector, (a) with a compass, (b) with GeoGebra. (Google pictures) ([https://www.google.com/search?biw=1267&bih=613&tbm=isch&sa=1&ei=tNVBW\\_itA7SQmgX0y5GIDQ&q=construcao+de+bissetriz+com+geogebra&oq=construcao+de+bissetriz+com+geogebra&gs\\_l=img\\_3...53759.55097.0.56359.8.8.0.0.0.158.447.6j1.7.0...0...1c.1.64.img..1.0.0...0.zjNwJK5PpWU#imgrc=\\_](https://www.google.com/search?biw=1267&bih=613&tbm=isch&sa=1&ei=tNVBW_itA7SQmgX0y5GIDQ&q=construcao+de+bissetriz+com+geogebra&oq=construcao+de+bissetriz+com+geogebra&gs_l=img_3...53759.55097.0.56359.8.8.0.0.0.158.447.6j1.7.0...0...1c.1.64.img..1.0.0...0.zjNwJK5PpWU#imgrc=_) Access: Jul. 8, 2018)

Digital geometry environments have introduced innovation and more choices into classrooms and into mathematics learning, such as the simultaneous exploration of possible movements (transformations) with the analysis of the preservation (or not) of Euclidean properties during such a transformation, and the potential for carrying out additional mathematical tasks in a dynamic way (Arzarello et al., 2002). For instance, one can see that the procedural dimension (construction techniques with a ruler, a compass, a protractor, etc.) gives way to conceptual comprehension, and a new understanding of properties, relationships among concepts, properties and geometric figures starts taking centre stage in the development of mathematical thinking using DGE.

It is worth remembering a didactic-conceptual recommendation changing regarding the use of the term software in the history of technology in Mathematics Education. Instead of software, is important to mention learning environment, because: (i) it is a scenario built by subjects who learn in the way they appropriate the technology, and reflect on their learning; (ii) it is enriched by the subject's interaction with technology and with his/her peers; (iii) it has a pedagogical purpose of the constructed scenario, notably, of the designed tasks; and (iv) that enhances different forms of communication (writings, gestures, touchscreen, pictorials, icons and screen capturing etc.). Finally, talking about the environment seeks to overcome the importance of technology per se and enhance the creativity and the autonomy of those who design and those who learn.

A fundamental design feature of most of DGEs is that all elements of a dynamic figure that depend on a given point move of such fundamental design feature a given base point move and such base point is dragged, and they move in a way such that the properties defined by the construction are maintained (Leung et al., 2013). The comprehension among properties of the objects, relations, and the dynamic of relations between different geometric objects happens frequently in GeoGebra (Alqahtani & Powell, 2020). When dragging objects in a given mathematic task

**Fig. 16.3** An equilateral triangle built using two congruent circles



(Fig. 16.3) teachers discuss and analyse the geometric objects and their interdependence.

In Fig. 16.3, point C is fixed, and points A and B are not. A and B are used to build both circles. Dragging A and B moves the circles, as these points are used in the construction of the circles. They are the centres of the circles. We see a relationship between the dependence and the construction. In this interactive identification we can see variable and invariable elements, as Alqahtani & Powell (2020) pointed out. Another interesting aspect is the fact that GeoGebra leaves a shadowed triangle, which is something that does not happen to circles. In fact, what is initially at play is the construction of the triangle. Nevertheless, with the movements, the circles, the points, and the segments come to integrate an exploratory and mathematical research scenario, which allows teacher and students to together create and enrich explorative, experimental, and deductive processes (Leung et al., 2013).

The possibility for mouse clicks or touching the screen directly, dragging and transforming a figure, maintaining or not its assumed Euclidean properties, has brought about some epistemological reflections (Arzarello et al., 2014, 2002). In a DGE the primitive Euclidean entities (points, straight lines, and planes) do not exist on their own, but rather coexist with a variety of geometric objects and constructions, each of which can be manipulated on the screen or through the mouse. Therefore, it is worth noting that the geometry produced in a DGE like GeoGebra is “another geometry”, since it has a new language with its own terms (variation of icons, forms of measurement, simultaneous observation of properties and shapes, etc.), as well as new ways of discovery and verification of properties. When combined with augmented reality (AR) devices, we have even greater challenging explorations possible for planes, projections and other relations in space.

In other words, in an historical and didactical perspective, what is taught with DGEs (or AR devices, GeoGebra AR for example) is a geometry, but not exactly Euclidean geometry. Traditional tools such as compass, rulers, etc. concretize



circles, lines, etc., which are the basis of Euclidean Geometry, and which have been used for centuries to exemplify the abstract objects of geometry, typically by physically drawing a specific case of a particular configuration. DGEs, in contrast, are tools to explore figures (not only drawing) in a geometry which is not exactly the same. AR devices go one step further. They recreate the reality of the physical world, which becomes a starting point for learning, and allows the user to experience virtual objects in another way, without losing contact with the everyday life environment. In this manner, AR apps establish another feeling of motion, scenario belonging and body projection, making it possible to drag, deform, transform, enlarge (or reduce) images, and highlight ways of seeing, manipulating, and experimenting within a three dimensional visual world, which can favour the intertwined development of the virtual visualization, representation, and prediction processes (Paulo et al., 2020). Again, I'm not saying it's better, but different and as researchers we need try to find and discuss such novelties, constrains, and affordances.

Up to now we can see procedures that have been left behind (some of them totally abandoned) even as thinking strategies have emerged, always associated with and emphasizing visualization, representation, and geometrical modes of communication. The great challenge remains, nevertheless: to understand new mathematics concepts. Returning to the special case of constructions, we can study how the construction of notable points (incentre, bisector and orthocentre) in a triangle have changed with the introduction of DGEs. All options for movement, transformation, the relationships among them, and related concepts (Euler's line, for instance) have intensified with the use of DGEs. We have also developed a keener attention to the type of task that is proposed, and to the emerging ways of reasoning (Bairral & Marques, 2016).<sup>7</sup>

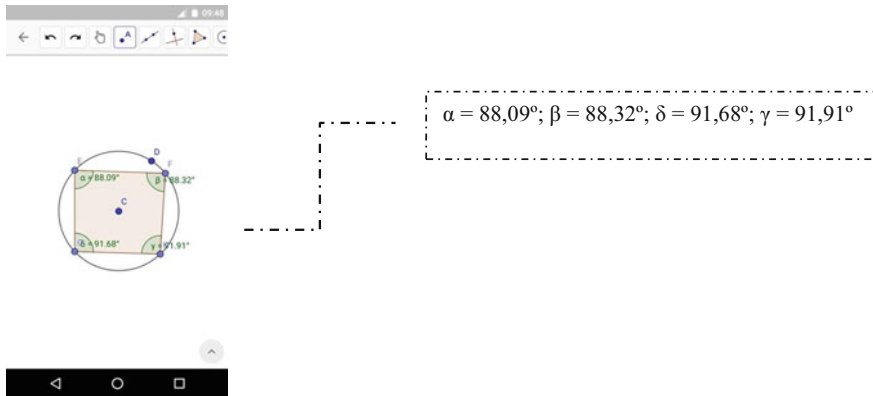
Human evolution and communication, and interaction among humans and humans, as well as between humans and machine, have all been influencing and altering mathematics concepts and classroom dynamics. The role played by technology shifted from being a visual amplifier or provider of data towards being an essential constituent of the meaning of tasks, and therefore has affected the conceptions of the mathematical objects that the subjects might construct (Laborde, 2001).

## DGEs Transforming Mathematics and Curricular Contents

A DGE should allow the user to interact constantly both with the device and with the other people in the group, as well as to move freely during the task among progress using various forms of communication, technological and geometric strategies. The use of a DGE provides interaction between the user and the construction: through trial and error; the possibility to formulate and verify conjectures, and the

---

<sup>7</sup>See a possibility in: <http://www.gepeticem.ufrj.br/pontos-notaveis-de-um-triangulo/> Access: Aug. 20, 2020.



**Fig. 16.4** Measures of the internal angles of the quadrilateral. (Source: Duarte (2018))

observation with different forms of visualising and representation (not static) of the mathematical object. DGEs also reveal the obsolescence of some formerly important curriculum topics. For example, operations with angle measurements using degrees minutes and seconds (addition, subtraction, multiplication, or division), should no longer be included in the Brazilian school curriculum. In the past, there were no tools to provide the result; we had to know how to calculate. Nowadays, GeoGebra, for instance, provides those measurements, as shown in Fig. 16.4.

Besides providing whole values for the angles, GeoGebra allows a user to construct and compare shapes, inscription, etc. It also offers the possibility to measure and analyse external angles. Measurement and comparison will certainly be reconfigured. Instead of calculating, what we can do is interpret and analyse various measurements, facilitating understanding of angles as dynamic objects, as “an opening”,<sup>8</sup> beyond the procedural tasks of calculations. Other explorations are now possible. For example, what does it mean to talk about “the non-whole part in each angle,  $\alpha$ ,  $\beta$ ,  $\delta$  e  $\gamma$ , respectively, 09°, 32°, 68° and 91°?” Furthermore, building only a bisector with GeoGebra, as shown in Fig. 16.2b,<sup>9</sup> is taking far too little advantage in exploring this resource, which allows the user to build and intertwine different constructs, concepts, properties, and establish relations among them.

Just as the DGE reconfigured the notion of dynamic related to compasses and pantographs, mobile devices have revolutionized the concepts of mobility and transformation. Although a compass can be constantly opened and closed, it is a device that lacks mobility or transformation. The construction generated on such a device is static, it is a drawing, a specific shape. A DGE used on a desktop is similarly static; despite constructions with several movements, the laptop also does

<sup>8</sup>The opening between two intersected lines or planes.

<sup>9</sup>The figure illustrates the beginning of the construction of the angle.

not possess mobility. However, a DGE used on a smartphone does have mobility. In the case of the compass and straight edge or the DGE on a laptop, the user needs to go to each of the devices and provoke their mobility by carrying them and physically moving or changing them. The DGE on the laptop is potentially endowed with mobility, although it can temporarily remain still (Bairral, 2019). I would like to stress here that, although compasses and mobile phones are mobile resources, the mobility of a smartphone is quite a different thing. With a smartphone, mobility comes along with two other characteristics of a MDwT: ubiquity (everywhere presence) and convergence (integration of different media). Once again, this does not mean that a smartphone is necessarily better than<sup>10</sup> a compass when it comes to making a construction. My intention is to provoke the reader to consider the transformations of the history of mathematics that have come about from resources, reconceptualization, and interactive dynamics. The mobility and sharability afforded by the smartphone creates possible designs for the teaching and learning of mathematics that are not possible to imagine as easily with historically earlier forms of technology.

In a DGE we have different possibilities for the construction of geometrical objects and relations among them. Particularly on a DGE with touchscreen, a learner can touch directly on the screen or perform other kinds of manipulations that simultaneously modify the constructed geometric object constructed (angles, sides, shape etc.). It should be stressed that the software on its own does not guarantee learning. Other factors, like multimodality of interaction, the sort of proposed task, interrelated with the experience of the specific device and its processes of semiotic mediation (Bussi & Mariotti, 2008), and so on, must be considered as interacting with each other to generate the learning environment with the touchscreen device (Bairral & Assis, 2017).

## Touchscreen Devices Entering the Learning Environment

Mobile devices such as smartphones and tablets constitute a physical extension of our bodies (Bairral, 2020), and as such, reconstruct our ways of thinking and interacting (Arzarello et al., 2014). I understand such devices as part of the process, and conceive them as more than mere resources that help teaching, since they also alter the process in which knowledge is built (Bairral, 2020). Therefore, a mobile device is a part of the learning scenario, which modifies the ways of thinking and decision taking in both the presentation and the resolution of a task (Bairral et al., 2022).

---

<sup>10</sup>In the research that I coordinate as well as in my teaching, I do not use adjectives such as new, good, better, as they express subjective views: what is old for one person may be new to somebody else.

As Bairral et al. (2017) have stressed, the increasing number of devices with touchscreen technology, as well as their appropriation by teachers and learners, have facilitated new outlooks on the way to teach and learn mathematics. The connectivity, ubiquity and mobility of these devices expands options for implementing teaching environments that include them, because they are so readily available, they foster learning, and they allow for a variety of tasks.

The applications on mobile devices, nevertheless, bring with them alternatives (not necessarily better) due to the possibility for manipulating on the screen. For example, in some applications<sup>11</sup> we need to make a transformation on the plane (rotation, symmetry of reflection, etc.) so that the pieces fit without overlapping. With conventional manipulative pieces (paper, or material such as E.V.A. foam for geometric shapes, puzzles etc.), even when we do make a similar movement (rotate, translate, etc.), it is not determinant to solve the puzzle

The proposed tasks in the research that I supervise are designed for small groups or pairs. They take place in classrooms (not in isolated groups) and engage learners with content prescribed in the school curriculum. We do not develop APPs; we design activities that can only be used with freely available APPs. We try to use the students' smartphones, and we also bring to the site of research phones that belong to our research group to lend to students who need one. In the next section I summarize, as an example of the changes in the learning environment that smartphones and touchscreens have introduced in recent years, some implications for learning concepts related to the study of straight lines intersected by a transversal line. This research used the GeoGebra with touchscreen App operating on the students' own smartphones<sup>12</sup> (Henrique & Bairral (2019b), Duarte & Bairral (2021), and Henrique & Bairral (2022)).

## Teaching Parallel Lines Intersected by a Transversal Line with the GeoGebra App

In Brazil, the teaching of parallel lines cut by a transversal is conventionally done by showing lines drawn on the blackboard; from the identification of angles and memorization of properties, equations are set to be solved. In truth, the focus of the lesson is eventually the resolution of the equation, so the learners work on their algebra rather than on any geometrical aspect.

I'll summarize the development of two tasks in which 8th grade primary school pupils interacted, researched, kept various records, and reported their discoveries, using the GeoGebra App.<sup>13</sup> Our research team concluded that the students had a

---

<sup>11</sup> See for example TANGRAM HD.

<sup>12</sup> See more details concerning task-design and students' interaction in Duarte (2018), Duarte and Bairral (2021), Henrique (2021), Henrique and Bairral (2019b), Henrique and Bairral (2022).

<sup>13</sup> Version Geometria – 5.0.485.0. Available at <https://www.geogebra.org/download>

wider and better articulated comprehension of geometric properties than typical classes taught in the more traditional way without smartphones. The use of smartphones proved stimulating, as it allowed students to observe a set of elements (angles, line position, etc.) articulated with the manipulation of the drawn straight lines. Results also suggested the efficacy of less focus on memorizing specialized terms (corresponding angles, opposite by vertex etc.) in order to facilitate a deeper understanding of angle properties and relations among them.

Initial research led to the belief that instruction and classroom dynamics with GeoGebra App for teaching parallel lines intersected by a transversal line would empower students with a good motivation for discovering, understanding, and adopting critical attitudes for learning geometry. Our research team designed tasks (see two examples in the Appendix)<sup>14</sup> that focused on the performance of geometry constructions with GeoGebra on the students' own smartphones. The tasks were designed to facilitate analysis of the relations that can be observed between two parallel lines intersected by a transversal line, particularly by investigating the properties between the possible pairs of angles formed by two parallel lines when they are intersected by a transversal. Data was collected through audio and video recordings, screen capture from individual devices, learners' written notes and the researcher's diary.

In the next section I will summarize results regarding the students' learning about (1) concurrent lines with angles (Appendix [Task 1](#)) and (2) parallel lines intersected by a transversal line<sup>15</sup> (Appendix [Task 2](#)).

### ***About Concurrent Lines with Angles (Task 1)***

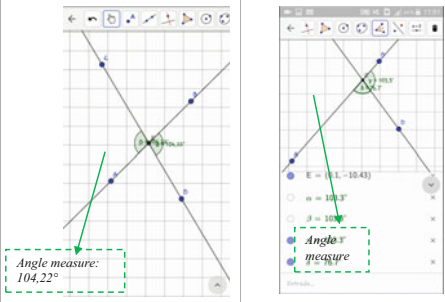
The students initially struggled with the construction of the angles opposed by the vertex, due to the particular shape demanded in the construction. Nevertheless, as the class progressed, the teacher tried to clear out the students' doubts and boost those pairs of learners who presented better performances by proposing new questions. The records presented in Chart 16.2 demonstrate the development of the tasks, mainly in terms of the learners' discoveries. In the first phase, the students were asked to construct two concurrent lines and a pair of angles opposed by the vertex. Although the students modified the presentation at times, indicating uncertainty about the construct, it can be inferred in a number of video sequences that they found it readily easy to observe that the angles remained congruent, even when modifying the construct.

In the next phase (relation between adjacent angles), the students experienced greater difficulty in identifying the relationship. It is possible that rounding up at one

---

<sup>14</sup>See complete set of tasks in Henrique and Bairral (2019a).

<sup>15</sup>I am making this section longer because it contains recent results from the research group that I coordinate ([www.gepeticem.ufrj.br](http://www.gepeticem.ufrj.br)) develops with DGEwT.

Video – Time	Screen Print Out (Task 1)
12:10 - 12:34	
Description	
Students B and G modifying the construct while trying to establish some relation between opposed angles and adjacent angles between concurrent lines.	

**Chart 16.1** Actions performed by students in [Task 1](#)

decimal place made this process more difficult. Observing the students' difficulties, the teacher suggested they try adding up the angles that were adjacent in the algebra field of the screen (as in the picture in [Chart 16.1](#)), and that they freely experiment with different straight lines to pursue a conjecture about the relationships with the pair of angles. This strategy facilitated the construction performance and the recognition of the property (adjacent angles are supplementary).

The research team concluded from the episode that the capacity to provide a non-static vision of geometry using GeoGebra made a significant contribution to the learning environment, and that this case is emblematic of a learning environment in which the use of mobile devices supports learning mathematics through tasks made possible by the non-static devices (Arzarello et al., 2014). The team also noted how the use of the devices stimulates research and the emergence of conjectures in the discovery of geometric properties, further highlighting the potentialities of DGEs.

### ***About Parallel Lines Intersected by a Transversal Line (Task 2)***

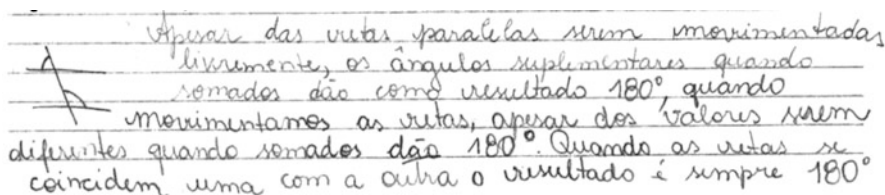
The second task aimed at working on existing properties between pairs of angles that can be formed from the construction of two parallel lines intersected by a transversal line. At the beginning of the task, some difficulties occurred in relation to both constructing with GeoGebra and with fidgety students, quite usual in this kind of task. During the implementation, the teacher tried to help the pairs of students who had more difficulties and to boost those who were faring well with the completion of the task. I have to stress that the interaction in a teaching-learning environment using DGEwT tends to be more dynamic, but it also demands a greater flexibility from the teacher in the solution of problems as well as in addressing other requests from the learners. Nevertheless, keeping the motivation and curiosity high on the part of learners is always a challenge.

## Moving from Only Nominating to Understandings, Sharing, and Publicizing Ideas and Justifications

A particular point of discussion is the use of specific jargon and naming in the study of properties pertaining to the intersection of parallel straight lines. Expressions like *interior alternate*, *exterior alternate*, *congruent*, *corresponding angles*, etc., may generate obstacles to learning. Faced with this recognition, this intervention chose to value the students' discoveries in terms of the properties and relations between the angles, their observation of the position of straight lines, and so on, in as natural a way as possible, and to downplay the naming of these properties and relations, which tends to be overemphasized when working on this subject. The task statement takes on the role of semiotic mediation (Bussi & Mariotti, 2008), and must be considered as part of the learning process. Particularly, the students' argumentative ideas - captured in their written register - deserves special attention. In answer to the question, *Move freely the transversal line and then the parallel lines. What can you see?* (Task 2, items 1.3 and 1.4), the students B and G wrote an interesting justification (Fig. 16.5), especially considering that this kind of pedagogical intervention was unusual for them:

The register created by the students demonstrates the importance of the use of writing in mathematical learning, highlighting the way it is used in the process of conceptual reflection. Yet, the drawing used by these learners suggests another way of understanding. Although some parts of the text are redundant, it seems clear enough that the learners checked the accuracy of the fact that the sum of the supplementary angles is  $180^\circ$  (in different positions, adjacent and not adjacent). According to the report, we can see that the registered observation was accomplished by dragging one of the lines closer to or superimposing it on the other. It is still likely that this fact has led to the remarks, although the learners did not point out other discoveries in relation to other pairs of angles (Chart 16.2).

However, it is possible to check, from the capture of the smartphone screen used by the pair of students, that other testings of the conjecture were carried out in their search for other findings, according to chart above. As we would like to show how



**Fig. 16.5** Written answer by students Band G (aged 13 and 14) ("In spite of the parallel straight lines being moved freely, the supplementary angles, when they are added, they add up to  $180^\circ$ , when we move the lines, despite the values being different, they sum up to  $180^\circ$ . When the lines coincide together with each other, the result is always  $180^\circ$ ")

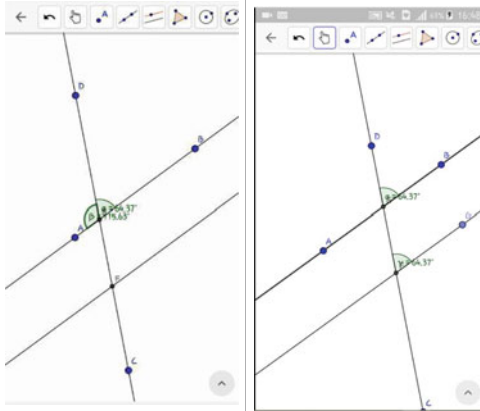
Video – Time	Screen Print Out (Task 2)
06:44 – 10:21	
<b>Description</b>	
Students B and G researching the relations between adjacent angles and corresponding angles	

Chart 16.2 Actions performed by students in Task 2

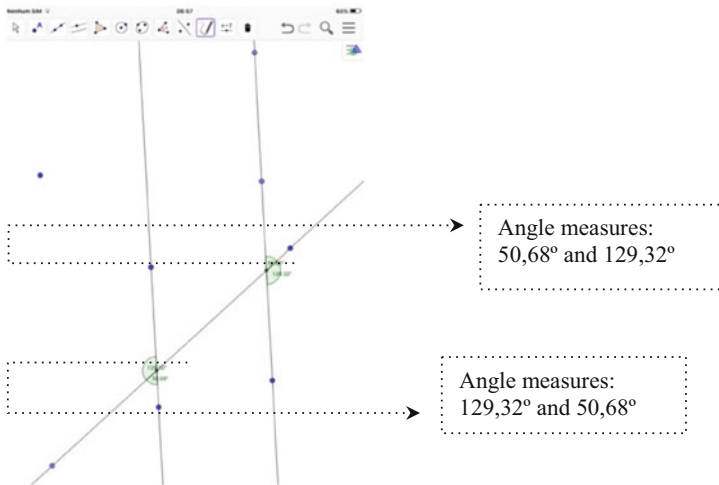


Fig. 16.6 Construction performed by the threesome H, L and J in activity 2. (Source: Duarte & Bairral (2021))

learners can also socialize their ideas, you can see that they made a print of the screen in their smartphone after completing the task (Fig. 16.6), and that they sent it to the WhatsApp group created at the beginning of the interventions. The measures of the angles are transcribed for better viewing.



The findings mentioned here also reveal the interactions (students–students, and students–DGEwT) that took place as the students were working on the task. The reflection presented in writing suggests a dialogue between them, prior to their writing, in which they formulated conjectures that arose during the altering and visualization of the mathematical object.

As for the smartphone, the motivating appeal of this resource must be stressed. Nevertheless, their use presents some challenges, as visualising properties on too small of a screen creates challenges. In terms of the tasks discussed in this chapter, I highlight five important findings: (1) difficulties in handling the software and visualizing properties in a construct when the screen is too small; (2) greater emphasis on exploring properties, without overvaluing naming; (3) use of writing and dialog as forms of reflection and conceptual development; (4) identifying properties and relations among angles is simplified; and (5) visualizing properties from possible combinations between pairs of angles was experienced by the students as challenging as they consolidated their findings, but the innovation introduced aspects that led to a more encompassing and articulated comprehension of the geometrical concepts studied.

I have observed that environments that centre mobile devices with touchscreens facilitate learning beyond identifying various angles and understanding properties (between straight lines and angles). Students in these environments manage to readily construct justifications for their reasoning, which would be difficult to do in traditional, more static approaches. Furthermore, with the variety of objects (angles and lines) that are at play, and moving around, the notion of reference comes to be a part of the content. Which angle? Which pair of lines should be considered? Although these considerations may sometimes be spontaneous, they are important to be considered in the learning of this topic.

The pedagogic intervention turned out to be stimulating, as it allowed students – through different modes of interaction, including written register and constructions on screen – an articulated observation of a set of elements (measurement or addition of angles, position of lines, etc.) and together with the handling of the DGE, the varied exploration of the construction of straight lines. The manner in which the mathematics content was approached enabled the students to develop an expanded conception of properties without emphasizing the naming of special objects and relationships. It is always up to the teacher to reflect on how much naming jargon is needed (adjacent, internal alternate, corresponding angles, etc.), since the naming may complicate the process, or undermine the understanding of identification and relation between angles and related properties. Based on this rich exploring process we defend instruction concerning parallel lines intersected by a transversal that minimizes names (corresponding angles, opposite by vertex etc.) in favour of a focus on angles relation and properties among the concepts.

## Conclusion

Expectations of classroom innovation and improvement in mathematics learning rest heavily on the use of didactic resources. The history of technology use for mathematics can be seen as a resource for conceptualizing learning. Resources do not always solve learning problems, and the focus of learning and teaching cannot be based solely on resources. Although some resources are developed to support the teaching of some specific content, it is possible to think of other alternatives from the interaction with such material. Particularly with DGEwT, we have seen changes over time, not only regarding content to be taught, but also in terms of new ways to propose tasks, in classroom dynamics and modes of communication and reflection on what is being learned, and in the possibilities for interaction among teachers and learners as learning unfolds. This may be recognized in the work with DGE (with or without screen touching) especially in how the experiences with this technology facilitate justification for reasoning and an expanded repertoire of argumentative forms. If we use MDwT, there are even more possibilities of communication and media convergence (as is the case of sharing through WhatsApp, or the production of short explanatory videos and other messages).<sup>16</sup> In this stimulating and motivating dynamic, we advocate for the use of technology in school mathematics.

Learners use technological resources for various purposes, but it is the role of the teachers to plan their use in the teaching of diverse content or in how they choose to interact with their students. According to Chao et al. (2016), teachers can use mobile devices to combine and engage in four types of communication that are likely to improve students' learning: *clarification* (when the teacher tries to understand exactly what a student did and why), *verification* (when the teacher asks confirmation questions about the student's strategy, restates a student's thinking, and asks for confirmation); *extension* (when the teacher broadens the original problem or task in order to build upon the student's strategy, requiring the ability to make inferences about what a student understands and then to formulate questions that probe into this thinking); or *redirection* (when the teacher redirects a student towards a teacher-presented strategy when the teacher feels they have heard enough of what a student is thinking, or thinks the student is headed down an incorrect path and decides to intervene by telling the student to use a particular alternative strategy). I agree with these authors; such types of listening with questioning of and responding to students may be used in teaching processes with or without mobile devices. Of course, every resource needs special attention concerning instruction and ways of interaction, yet it is rarely the specific resource that determines good pedagogical use of that resource. For a didactic introduction of smartphones into classrooms - in the same manner as the introduction into classrooms of any pedagogical tool, it is necessary to identify potentialities and limitations of the device. Some challenges are related to the

---





<sup>16</sup>In this chapter I didn't pay attention to touches on screen as a new semiotic resource. You will find these ideas in Arzarello et al. (2014), Bairral et al. (2017), Bairral (2020), and Bairral & Assis (2022).

performing of constructions or difficulties in visualizing properties when the smartphone screen is small. Nevertheless, this difficulty in visualizing tends to be considered as natural in the discovery process by the students, and seems to rarely introduce barriers to learning.






The dynamic performance of the device, the easy use and handling on the screen and the possibility to repeatedly see the construction steps increases the learners attention during the tasks, and provokes greater engagement with the mathematics that they are learning (Bairral et al., 2015). The simultaneous analysis of several elements (angles, lines, intersections, etc.), and the need to take reference (line, angles, and side) into account, constitutes a vast and stimulating field of geometrical exploration that widens the visual and representational range of geometrical objects. It becomes important to the learners that they pay special attention to geometrical objects and the relations that they aim to analyse. The mediation of the teacher is also important, because the teacher can take on the functions of an observer and a constant propeller of ideas and interlocution with the learners.

## Appendix

### Task 1

1. Construct two concurrent straight lines. **Hint:** Use the tool **Straight Line** 
  - 1.1. Using the tool **Intersection of two objects**  construct the point where both lines concur.
  - 1.2. From the lines that you have built, move the angles opposed by the vertex. **Hint:** With the selected tool **Angle**  touch three consecutive points clockwise.
  - 1.3. Move the straight lines freely. **Hint:** Use the tool **Move** 
  - 1.4. What have you seen?
  - 1.5. Is there any relation between the angles? If so, what?
  - 1.6. What relation is there between adjacent angles? Explain.
2. Build a short text to tell your discoveries. Try to specify what you have learnt from manipulating GeoGebra. If necessary, make drawings in order to exemplify.

## Task 2

1. Construct two parallel lines. **Hint:** Use the tool **Straight line**  then select **Parallel line**  and touch on the built straight line and on another point in the area of construction.
  - 1.1. Construct one straight line transversal to the parallel lines. 
  - 1.2. With the selected tool **Angle**  construct the eight angles that can be formed from the parallel lines with their transversal line.
  - 1.3. Move freely  the transversal line, and then the parallel lines.
  - 1.4. What relations are there between the possible combinations of pairs of angles?
  - 1.5. Research other relations between the pairs of angles that can be formed. As always, register your remarks and if necessary, make a drawing in order to clarify your discoveries. When you are done, print out and save the construction.

## References

- Adler, J. (2000). Conceptualising resources as a theme for teacher education. *Journal of Mathematics Teacher Education*, 3, 205–224.
- Alqahtani, M. M., & Powell, A. B. (2020). Crescimento colaborativo do conhecimento de professores em um ambiente online de geometria dinâmica. In M. Bairral (Ed.), *Ambiências e redes online: interações para ensino, pesquisa e formação docente*. São Paulo.
- Arzarello, F., Olivero, F., Paola, D., & Robutti, O. (2002). A cognitive analysis of dragging practises in Cabri environments. *ZDM*, 34(3), 66–72.
- Arzarello, F., Bairral, M., & Dané, C. (2014). Moving from dragging to touchscreen: Geometrical learning with geometric dynamic software. *Teaching Mathematics and its Applications*, 33(1), 39–51. <https://doi.org/10.1093/teamat/hru002>
- Bairral, M. A. (2019). Dimensions to be considered in teaching, learning and research with Mobile devices with touchscreen. *Acta Scientiae*, 21(2), 93–109. <https://doi.org/10.17648/acta.scientiae.v21iss2id5040>
- Bairral, M. (2020). Not only what is written counts! Touchscreen enhancing our cognition and language. *Global Journal of Human-Social Science (G)*, 20(5), 1–10. <https://doi.org/10.17406/GJHSS>
- Bairral, M., & Assis, A. (2017). Touchscreen devices and task design to improve plane transformation in high school classroom. *Quaderni di Ricerca in Didattica: Matematica*, 27-(Supplemento n. 2), 135–139.
- Bairral, M., & de Assis, A. R. (2022). Isometries: Epistemological insights among secondary students interacting in dynamic geometric environment with touchscreen. *International Journal for Research in Mathematics Education (RIPEM)*, 12(22), 92–121. <https://doi.org/10.37001/ripem.v12i2.2834>

- Bairral, M. A., & de Marques, F. J. R. (2016). Onde se localizam os pontos notáveis de um triângulo? Futuros professores de matemática interagindo no ambiente VMT com GeoGebra. *Educação Matemática Pesquisa*, 18(1), 111–130.
- Bairral, M. A., Assis, A., & da Silva, B. C. C. (2015). Uma matemática na ponta dos dedos com dispositivos touchscreen. *RBECT*, 8(4), 39–74. <https://doi.org/10.3895/rbect.v8n4.1754>
- Bairral, M., Arzarello, F., & Assis, A. (2017). Domains of manipulation in touchscreen devices and some didactic, cognitive and epistemological implications for improving geometric thinking. In G. Aldon, F. Hitt, L. Bazzini, & U. Gellert (Eds.), *Mathematics and technology: A C.I.E.A.E.M source book* (pp. 113–142). Springer.
- Bairral, M., Henrique, M. P., & Assis, A. (2022). Moving parallel and transversal lines with touches on smartphones: A look through screenrecording. *The Mathematics Enthusiast*, 19(1), 114–135.
- Ball, D. L., Thames, M. H., & Phelps, G. (2008). Content knowledge for teaching: What makes it special? *Journal of Teacher Education*, 59(5), 389–407. <https://doi.org/10.1177/0022487108324554>
- Bussi, M. G. B., & Mariotti, M. A. (2008). Semiotic mediation in the mathematics classroom: Artifacts and signs after a Vygotskian perspective. In *Handbook* (pp. 746–783).
- Chao, T., Murray, E., & Star, J. (2016). Helping mathematics teachers develop noticing skills: Utilizing smartphone technology for one-on-one teacher/student interviews. *Contemporary Issues in Technology and Teacher Education*, 16(1), 22–37.
- Duarte, R. C. B. C. (2018). *Utilização do GeoGebra, de smartphone e de reflexões escritas na construção de conceitos relacionados a retas paralelas cortadas por uma transversal*. Master Dissertation. Seropédica: UFRRJ/PPGEduCIMAT.
- Duarte, R., & Bairral, M. (2021). Smartphone e GeoGebra: Um convívio não paralelo em sala de aula. In M. Bairral & M. P. Henrique (Eds.), *Smartphones com toques da Educação Matemática: Mãos que pensam, inovam, ensinam, aprendem e pesquisam* (pp. 65–100). CRV.
- Henrique, M. P. (2021). *Metáforas e Toques em Tela: Potencializando Aprendizagens Discentes no Estudo de Retas Paralelas e Transversais*. Doctoral Thesis in Education. Seropédica: UFRRJ/PPGEduCIMAT.
- Henrique, M. P., & Bairral, M. (2019a). *Caderno de Atividades sobre Conceitos Geométricos em Ambientes de Geometria Dinâmica (eBook)* (p. 49) Retrieved from <http://r1.ufrj.br/edur/loja/caderno-de-atividades-sobre-conceitos-geometricos-em-ambientes-de-geometria-dinamica/>
- Henrique, M. P., & Bairral, M. (2019b). Touching, moving and understanding properties related with parallel lines intersected by a transversal line with GeoGebra on smartphones. *Quaderni di Ricerca in Didattica: Matematica*, 3(Special Issue Proceedings CIEAEM70), 109–116.
- Henrique, M. P., & Bairral, M. (2022). Straight Lines and Angles that Move, Students' Ideas that Touch and Add. *Acta Scientiae*, 24(8), 315–339. <https://doi.org/10.17648/acta.scientiae.7129>
- Izar, S. B. (2016). Museu Virtual: Pantógrafos e Homotetia em aulas de Matemática. *Boletim Gepem*, 69, 162–169. <https://doi.org/10.4322/gepem.2017.013>
- King, J., & Schattschneider, D. (1997). *Geometry turned on: Dynamic software in learning, teaching, and research* (n. 41). Cambridge University Press.
- Laborde, C. (2001). Integration of technology in the design of geometry tasks with Cabri geometry. *International Journal of Computers for Mathematical Learning*, 6(3), 283–217.
- Leung, A., Baccaglioni-Franck, A., & Mariotti, M. (2013). Discernment of invariants in dynamic geometry environments. *Educational Studies in Mathematics*, 84(3), 430–460.
- Noss, R., Healy, L., & Hoyles, C. (1997). The construction of mathematical meanings: Connecting the visual with the symbolic. *Educational Studies in Mathematics*, 33, 203–233. <https://doi.org/10.1023/A:1002943821419>
- Paulo, R. M., Pereira, A. L., & Pavanelo, E. (2020). The constitution of mathematical knowledge with augmented reality. *The Mathematics Enthusiast (TME)*, 18(3), 640–668. Retrieved from <https://scholarworks.unt.edu/tme/vol18/iss3/11>

# Conclusion of the Book

This book collects reflections coming from recent CIEAEM meetings and is therefore only a snapshot at one point in time of the commission's ongoing work to improve mathematics education by taking into account history and its implications for today's world. Different approaches have been proposed and tried for Mathematics Education using, integrating, or being influenced by the History of Mathematics, which we can summarize in three broad categories:

1. History as a motivator— teaching through History has the potential to make content more interesting. History can provide entertaining stories, contexts that explain purposes for the mathematics, and in these ways make mathematics more “human” by implicitly or explicitly teaching students that actual people living in (their) real world “made” mathematics – whether it was for a practical purpose, a recreational adventure, a link with other scientific subjects (STEAM) or for other reasons (e.g., personal aggrandizement, competition for celebrity or employment, etc.). Such a message about mathematics can in turn facilitate learners as understanding themselves as creators of mathematics.
2. History as a cognitive Tool – learners have to understand mathematics as created by people in a particular time, place, culture, class position, ethnicity, etc., and to (hopefully as a result) see themselves as doing, or able to be doing, the same thing. Historical texts provide materials that can be studied with this approach, comparing different texts with others, or simply doing the challenging work of trying to understand these texts as mathematicians doing mathematics – it creates a world that must be entered as mathematical anthropologists, so to speak.
3. History in a context of Evolutionary Assumption – some believe it e efficacious to have learners travel the very same journey in the development of mathematical ideas that their reading of the history has led them to believe was the evolution of these ideas – ontogeny recapitulates phylogeny: on the one hand, ontogeny through the biology of development presents the history as structural changes of institutions and the consequences on people. And on the other hand, phylogeny

emphasises the relationship of kinship, trying to understand the historical relationships between groups and organisms.

But the greatest concern is WHOSE history is the history of mathematics? We must take seriously that the “history” is often only the history of western mathematics. This is a result of colonialism, but also now is a perpetuation of coloniality, the unequal distribution of power, knowledge, etc., in the world. Alan Bishop’s conception of mathematics as culturally universal according to six ways of being mathematical can be the start of a history of mathematics. (Yet, Bishop himself was a western anthropologist of mathematics education, so we need to continue to be reflexive in this application of his ideas!) There is an idea of empowering learners by helping them learn mathematics via the local cultural history of mathematics – Chicano and Central American Latino study of Mayan and Inca mathematics, South Pacific Islander study of Maori, Filipino, Fijian, etc. mathematics, African Fractal cosmologies and cultures, Inuit and Navajo conceptions of space and place as perhaps the only hope for new forms of science and engineering that can save the planet, are examples. Also, Brazilian landless rights movements. The notion is to say, “we” are the creators of the most important mathematics. Similarly, some historians “rewrite” European history to “correct” that history and show that most innovations are migrations from the East . . . mathematical ideas and technologies, notation systems, and more. Teaching mathematics “without its history” can only be really understood in this way as cultural imperialism, as teaching all students that mathematics is really only school mathematics, and therefore is really only Western/European mathematics.

Another key point is the discussion of the Role of Technology in the History of Mathematics and the History of Mathematics Education. Following the anthropologist Clifford Geertz (Geertz, Clifford. “Thick Description: Toward an Interpretive Theory of Culture”. In *The Interpretation of Cultures*. New York: Basic Books, 1973.) Technology and culture are mutually evolving with and through the mediation and influence of the other. So we see in the chapters in this book that the history of mathematics, the history of the teaching of mathematics, and the history of new technologies, from writing tools and notational systems and printing technologies and dissemination of knowledge technologies and electronic technologies and . . . and . . . and dynamic touchscreen technologies, that technological innovations often inspire new forms of mathematics, new forms of pedagogy, and new ways to research about mathematics and mathematics pedagogy. We also see that new needs in the culture lead to new kinds of technologies, new kinds of mathematics, and new sorts of pedagogies. We also see that innovations in social structures are the result of new mathematics or new technologies, while new technologies change the knowledge that learners bring to their school mathematics lessons, that teachers bring to their understanding of mathematics, learners, schools, etc., and that contemporary imperatives that are the result of uncontrolled, carbon-based technologies have created an urgent need for much more innovation in all of these things.

An interesting approach to curriculum development for mathematics education might be to use the history of technology and its social, political, cultural and ideological contexts as the focus for indirectly learning mathematics in an interdisciplinary STEAM design. In this interdisciplinary approach, students would learn the mathematics they need in order to understand the technological innovation and how it works, why it was needed, and in terms of the mathematics that people of that time understood and used. This would turn mathematics into a tool for the history of technology and a source of questions to advance within technological innovation. This is provocative, since mathematics as a tool is usually understood as helping science and engineering, rather than history. But this change of viewpoint could be interesting.

In the development of technology, touchscreens on mobile devices create all sorts of exciting possibilities! Learners can experience mathematics as dynamic discovery, much as a scientist “experiments” based on first initial collection of cases and then interventions based on hypotheses. At the same time, teachers might carry out formative assessments, by observing and also by collecting documentation that reveals student thinking and their spontaneous use of previous knowledge. Researchers can learn more about students because the trace / record of student activity can be collected as data for analysis. Studying the history of mathematics and how concepts may have come into being raise concerns about the dangers of overwhelming surveillance. When student activity is forever available as records, are we violating personal privacy and integrity?

The fantasy that technologies will transform pedagogy and knowledge is a common trope in history – would radio change education? Will TV? Telephones? Film? Whiteboards? Computers? Our fantasies are never fulfilled. Can we learn from history and understand the limitations of technology for truly changing pedagogy? Technology that could be considered as obsolete in certain parts of the world persist in high importance in others, as for example radio, which reaches people at great distances in all parts of the world. The experience of Radio Nacional de España is a good example: it was a milestone in mathematics education in Andalusia, and a novelty in Spain, where the character of Thales as a narrator of the history of mathematics was included throughout the centuries with the inclusion of problem-solving, through the antenna, aimed at schools and the general audience.

There is so much more needed to be done! As examples, to give the focus on gendered mathematics and the place of scientists who identify as female in the history of mathematics, as well as in its future. Mathematics could be comprehended as a tool of understanding the past as well as the evolution of societies, without forgetting maths as a tool of violence in a world where climate disruption is inevitably leading to the multiplication of climatic catastrophes. In this latter sense, it appears that mathematics cannot be taught and cannot be learned without a deep understanding of how mathematics fits into the cultural, social and political construction of the world around us. Which leads us to advocate for the integration of these historical aspects into curricula, teacher training, and ongoing professional development.



# References

- Aaboe, A. (1963). *Episodes from the early history of mathematics*. Mathematical Association of America. ISBN: 0-88385-613-1.
- Abar, C. A. A., & Dos Santos, J. M. (2021). Mapeamento dos artigos publicados na Revista do Instituto GeoGebra Internacional de São Paulo entre 2013 e 2018. *Revista de Matemática, Ensino e Cultura*, 16(37), 01–13.
- Ackermann, E. (1991). From Decontextualized to situated knowledge: Revising Piaget's water-level experiment. Epistemology and learning group. In I. Harel & S. Papert (Eds.), *Construcionism* (pp. 269–294). Ablex Publishing Corporation.
- Adler, J. (2000). Conceptualising resources as a theme for teacher education. *Journal of Mathematics Teacher Education*, 3, 205–224.
- Ageron, P., & Hedfi, H. (2020). Ibrāhīm al-Balīshṭār's book of arithmetic (ca. 1575): Hybridizing Spanish mathematical treatises with the Arabic scientific tradition. *Historia Mathematica*, 52, 26–50. <https://doi.org/10.1016/j.hm.2020.01.002>
- Aguilera, D., Lupiáñez, J. L., Vílchez-González, J. M., & Perales-Palacios, F. J. (2021a). In search of a long-awaited consensus on disciplinary integration in STEM education. *Mathematics*, 9, 597. <https://doi.org/10.3390/math9060597>
- Aguilera, D., Lupiáñez, J. L., Vílchez-González, J. M., & Perales-Palacios, F. J. (2021b). In search of a long-awaited consensus for STEM education. A framework proposal. In M. N. Bowman (Ed.), *Topics in science education* (pp. 101–136). Nova Science Publishers.
- Ainscow, M. (2001). *Desarrollo de escuelas inclusivas. Ideas, propuestas y experiencias para mejorar las instituciones escolares*. Ed. Narcea.
- Ainscow, M. (2004). Developing inclusive education systems: What are the levers for change? *Journal Education Change*, 6, 109–124. <https://doi.org/10.1007/s10833-005-1298-4>
- Akerson, V. L., & Guo, M. (2020). Reflection on Part III: Critical questions in STEM. In V. L. Akerson & G. A. Buck (Eds.), *Critical questions in STEM education* (pp. 255–256). Springer Nature. [https://doi.org/10.1007/978-3-030-57646-2\\_2](https://doi.org/10.1007/978-3-030-57646-2_2)
- Akizuki, Y. (1959). Proposal to I.C.M.I. *L'Enseignement mathématique*, Genebra, 5(4), 288–289. <https://www.e-periodica.ch/cntmng?pid=ens-001:1959:5::109>
- Albuquerque, L. M. (1963). Notas sobre a obra e o seu autor. In G. Nicholas (Ed.), *Tratado da Prática Darismética* (Edições Fac-Similadas). Livraria Civilização.
- Aldon, G. (2015). Technology and education: Frameworks to think mathematics education in the twenty-first century. In U. Gellert, J. Giménez, C. Hahn, & S. Kafoussi (Eds.), *Educational paths to mathematics a CIEAEM sourcebook* (pp. 365–381). Springer.

- Aldon, G., & Panero, M. (2020). Can digital technology change the way mathematics skills are assessed? *ZDM*, 52, 1333–1348.
- Aldon, G., Hitt, F., Bazzini, L., & Gellert, U. (Eds.). (2017). *Mathematics and technology. A C.I.E. A.E.M. Sourcebook*. Springer.
- Aldon, G., Arzarello, F., Panero, M., Robutti, O., Taranto, E., & Trgalová, J. (2019). MOOCs for mathematics teacher education to foster professional development: Design principles and assessment. In G. Aldon & J. Trgalová (Eds.), *Technology in Mathematics Teaching* (pp. 223–246). Springer.
- Alfaro, C., Flores, P., & Valverde, G. (2020). *Conocimiento especializado de profesores de matemática en formación inicial sobre aspectos lógicos y sintácticos de la demostración*. PNA 14:2, 85–117, <https://doi.org/10.30827/pna.v14i2.9363>.
- Allan, G. (2020). Qualitative research. In I. G. Allan & C. Skinner (Eds.), *Handbook for research students in the social sciences* (pp. 177–189). Routledge.
- Almeida, M. E. B. (2000). *O computador na escola: contextualizando a formação de professores*. Dissertation, Doctor in Education, São Paulo: Programa de Pós-Graduação em Educação: Currículo, Pontifícia Universidade Católica de São Paulo.
- Almeida, M. E. B., & Valente, J. A. (2011). *Tecnologias e Currículo: trajetórias convergentes ou divergentes?* Paulus.
- Almeida, M. V. R., Ribeiro, M., & Fiorentini, D. (2021). *Mathematical specialized knowledge of a mathematics teacher educator for teaching divisibility*. PNA, 15:3, 187–210, <https://doi.org/10.30827/pna.v15i3.15778>.
- Almouloud, S. A., Bongiovanni, V., & Campos, T. (1998). Les coniques: Construction d'une séquence didactique avec Cabri-Géomètre. *Scientia Paedagogica Experimentalis*, 35(1), 119–159.
- Alqahtani, M. M., & Powell, A. B. (2020). Crescimento colaborativo do conhecimento de professores em um ambiente online de geometria dinâmica. In M. Bairral (Ed.), *Ambiências e redes online: interações para ensino, pesquisa e formação docente*. São Paulo.
- Amador, J., Bragelman, J., & Superfine, A. (2021). Prospective teachers' noticing: A literature review of methodological approaches to support and analyze noticing. *Teaching and Teacher Education*, 99, 103256. <https://doi.org/10.1016/j.tate.2020.103256>
- Ambrosio, U. (2006). *Ethnomathematics: Link between traditions and modernity*. Brill – Sense.
- Anacona, M. (2003). La historia de las matemáticas en la educación matemática. *Revista EMA*, 8(1), 30–46.
- Ananiadou, K., & Claro, M. (2009). *21<sup>st</sup> century skills and competences for new millennium learners in OECD countries*. Organisation for Economic Cooperation and Development. EDU Working paper no. 41. Retrieved from [http://www.oalis.oecd.org/oalis/2009doc.nsf/linkto/edu-wkp\(2009\)20](http://www.oalis.oecd.org/oalis/2009doc.nsf/linkto/edu-wkp(2009)20)
- Andersen, L. R. (2019). *The Bildung Rose*. <https://nordicbildung.org/papers/the-bildung-rose/>
- Andersen, L. R. (2020). *Bildung: Keep Growing*. Nordic Bildung. Report to the Club Rome, 171. <http://nordicbildung.org/books/bildung/>
- Andrade, P. F. (1993). (org.) *Projeto EDUCOM: realizações e produtos*. Ministério da Educação e Organização dos Estados Americanos.
- Andrescu, T., et al. (2010). In Birkhäuser (Ed.), *An introduction to Diophantine equations. A problem-based approach* (pp. 67–70). Springer.
- Andreis-Witkoski, S. (2020). Desafios no processo de letramento de alunos surdos (Challenges in the process of literacy of deaf students). *Revista (Con)Textos Linguísticos, Vitória*, 14(27), 309–311. <https://www.educacion.gob.ec/wp-content/uploads/downloads/2014/03/MOSEIB.pdf>
- Anglin, W. S. (1994). *Mathematics: A concise history and philosophy*. ISBN 0-387-94280-7 e ISBN 978-0-387-94280-3.
- Anhalt, C. O., Staats, S., Cortez, R., & Civil, M. (2018). Mathematical modeling and culturally relevant pedagogy. In Y. J. Dori, Z. R. Mevarech, & D. R. Baker (Eds.), *Cognition, metacognition, and culture in STEM education. Teaching, learning and assessment* (pp. 307–330). Springer International Publishing AG.

- Anka, S. S. (1980). *Development, service and application of information and communication technology (ICT) in education*. Journal homepage: [www.ijrpr.com](http://www.ijrpr.com). ISSN, 2582, 7421.
- Antinucci, F. (2001). *La scuola si è rotta. Perché cambiano i modi di apprendere*. Laterza.
- Appelbaum, P. (1995). *Popular culture, educational discourse, and mathematics*. State University of New York Press.
- Appelbaum, P. (2008). *Embracing mathematics: On becoming a teacher and changing with mathematics*. Routledge.
- Appelbaum, P., & Allen, D. S. (2008). *Embracing mathematics: On becoming a teacher and changing with mathematics*. Routledge.
- Appelbaum, P., & Stathopoulou, C. (2015). Critical issues in culture and mathematics learning. In L. English & D. Kirshner (Eds.), *Handbook of international research in mathematics education* (pp. 744–798). Taylor and Francis.
- Appelbaum, P., & Stathopoulou, C. (2020). The taking of Western/Euro mathematics as reappropriation/repair. *Revemop*, 2, e202003.
- Appelbaum, P., Stathopoulou, C., & Xenofontos, C. (2022). Mathematics education as dystopia: A future beyond. *Journal of Humanistic Mathematics*, 12(2) <https://scholarship.claremont.edu/jhm/vol12/iss2/2/>
- Appelbaum, M. (2015). Activating pre-service mathematics teachers' critical thinking. *European Journal of Science and Mathematics Education*, 3(1), 77–89.
- Aravena, M. (2001). Evaluación de proyectos para un curso de álgebra universitaria. Un estudio basado en la modelización polinómica. *Tesis Doctoral. Departament de Didàctica de la Matemàtica i de les Ciències Experimentals*. Barcelona (España).
- Aravena, M., & Caamaño, E. C. (2007). Modelización matemática con estudiantes de secundaria de la comuna de Talca, Chile. *Estudios Pedagógicos XXXIII*, 2, 7–25.
- Arboleda, L. C. (1983). Historia y enseñanza de las matemáticas (n° 4, *Serie Epistemología, Historia y Didáctica de la Matemática*). Universidad Nacional de Colombia.
- Arcavi, A. (1991a). Two benefits of using history. *For the learning of mathematics* (Vol. 11, N° 11), pp 11). Flm.
- Arcavi, A. (1991b). Two benefits of using history. *For the Learning of Mathematics*, 11(2), 11.
- Arcavi, A., & Bruckheimer, M. (2000). Didactical uses of primary sources from the history of mathematics. *Themes in Education*, 1, 55–74.
- Arcavi, A., & Isoda, M. (2007). Learning to listen: From historical sources to classroom practice. *Educational Studies in Mathematics*, 66(1), 111–129. <https://doi.org/10.1007/s10649-006-9075-8>
- Areas, E. das N. (1999). *Sobre Simetrias e Ornamentos*. Thesis, Master in Mathematics. Universidade Estadual de Campinas – UNICAMP.
- Arseven, A. (2015). Mathematical modelling approach in mathematics education. *Universal Journal of Educational Research*, 3(12), 973–975.
- Artigue, M. (2000). Instrumentation issues and the integration of computer technologies into secondary mathematics teaching. *Proceedings of the Annual Meeting of GDM*. Potsdam. Retrieved from <http://webdoc.sub.gwdg.de/ebook/e/gdm/2000>, June, 2014.
- Artigue, M. (2002a). L'intégration de calculatrices symboliques à l'enseignement secondaire: les leçons de quelques ingénieries didactiques. In D. Guin & L. Trouche (Eds.), *Calculatrices Symboliques transformer un outil en un instrument du travail mathématique: un problème didactique* (pp. 277–349). La Pensée Sauvage.
- Artigue, M. (2002b). Learning mathematics in a CAS environment: The genesis of a reflection about instrumentation and the dialectics between technical and conceptual work. *International Journal of Computers for Mathematical Learning*, 7(3), 245–274.
- Arzarello, F., & Soldano, C. (2019). Approaching proof in the classroom through the logic of inquiry. In G. Kaiser & N. Presmeg (Eds.), *Compendium for early career researchers in mathematics education. ICME-13 Monographs*. Springer.
- Arzarello, F., Olivero, F., Paola, D., & Robutti, O. (2002). A cognitive analysis of dragging practises in Cabri environments. *ZDM*, 34(3), 66–72.

- Arzarello, F., Bairral, M., & Dané, C. (2014). Moving from dragging to touchscreen: Geometrical learning with geometric dynamic software. *Teaching Mathematics and its Applications*, 33(1), 39–51. <https://doi.org/10.1093/teamat/hru002>
- Ascher, M. (1990). A river-crossing problem in a cross-cultural perspective. *Mathematics Magazine*, 63(1), 26–29.
- Atiyah, M. (2000). *In mathematics: Frontiers and perspectives, by the International Mathematical Union*. Publications of the American Mathematical Society.
- Atiyah, M. (2014). *Collected works. Volume 7: 2002–2013*. Oxford University Press.
- Aurel, M. (1552). *Libro primero, de Arithmetica Algebraica*. Casa de Ioan de Mey Flandro.
- Ausejo, E., & Medrano, F. (2012). La fundamentación del Calculus en España: el Cálculo Infinitesimal en Gabriel Ciscar (1760–1829). *Llull: Revista de La Sociedad Española de Historia de Las Ciencias y de Las Técnicas*, 35(76), 305–316.
- Aydin, C. H., & Tasci, D. (2005). Measuring readiness for E-learning: Reflections from an emerging country. *Educational Technology & Society*, 8, 244–257.
- Babbage, C. (1889/2010). *Calculating engines*. Cambridge University press. Retrieved on June 2022 the 13th from [https://web.archive.org/web/20160304104606/http://monoskop.org/images/4/40/Babbage\\_Charles\\_Calculating\\_Engines.pdf](https://web.archive.org/web/20160304104606/http://monoskop.org/images/4/40/Babbage_Charles_Calculating_Engines.pdf)
- Baccaglioni-Frank, A. (2010). *Conjecturing in dynamic geometry: A model for conjecture-generation through maintaining dragging*. Doctoral dissertation, University of New Hampshire.
- Baccaglioni-Frank, A. (2012). Dragging and making sense of invariants in dynamic geometry. *Mathematics Teacher*, 105(8), 616–620.
- Bach, E., & Shallit, J. (1996). Algorithmic number theory. *Volume I: Efficient algorithms*. Chapter 4: The greatest common Divisor. MIT Press.
- Bacon, F. (1620). *Novum Organum*. In Ed. Losada-2004. *Buenos Aires* (Argentina).
- Badillo, E., Figueiras, L., Font, V., & Martínez, M. (2013). Visualización gráfica y análisis comparativo de la práctica matemática en el aula. *Enseñanza de las ciencias*, 31(3), 207–225.
- Bails, B. (1776). *Principios de matematica donde se enseña la especulativa, con su aplicacion a la dinámica, hidrodinámica, óptica, astronomía, geografia, gnomónica, arquitectura, perspectiva, y al calendario*. Joachin Ibarra.
- Bails, B. (1779). *Elementos de matemática*. Tomo II .
- Bairral, M. A. (2007). Building a community of practice to promote inquiry about geometry: A study case of preservice teachers interacting online1. *Interactive Education Multimedia*, 14, 40–53.
- Bairral, M. A. (2013). Do clique ao touchscreen: novas formas de interação e de aprendizado matemático. *Anais 36ª Reunião Nacional da ANPED, Goiânia*.
- Bairral, M. A. (2019). Dimensions to be considered in teaching, learning and research with Mobile devices with touchscreen. *Acta Scientiae*, 21(2), 93–109. <https://doi.org/10.17648/acta.scientiae.v21iss2id5040>
- Bairral, M. (2020). Not only what is written counts! Touchscreen enhancing our cognition and language. *Global Journal of Human-Social Science (G)*, 20(5), 1–10. <https://doi.org/10.17406/GJHSS>
- Bairral, M., & Assis, A. (2017). Touchscreen devices and task design to improve plane transformation in high school classroom. *Quaderni di Ricerca in Didattica: Matematica*, 27-(Supplemento n. 2), 135–139.
- Bairral, M., & de Assis, A. R. (2022). Isometries: Epistemological insights among secondary students interacting in dynamic geometric environment with touchscreen. *International Journal for Research in Mathematics Education (RIPEM)*, 12(22), 92–121. <https://doi.org/10.37001/ripem.v12i2.2834>
- Bairral, M. A., & de Marques, F. J. R. (2016). Onde se localizam os pontos notáveis de um triângulo? Futuros professores de matemática interagindo no ambiente VMT com GeoGebra. *Educação Matemática Pesquisa*, 18(1), 111–130.

- Bairral, M. A., & Powell, A. B. (2013). Interlocution among problem solvers collaborating online: A case study with prospective teachers. *Pro-Posições*, 24(1), 1–16. <https://doi.org/10.1590/S0103-73072013000100005>
- Bairral, M. A., Giménez, J., & Rosich, N. (2005). Debate Virtual y Desarrollo Profesional. Una Metodología para el Análisis del Discurso Docente. *Revista de Educación*, 336, 439–465.
- Bairral, M. A., Arzarello, F., & de Assis, A. R. (2015a). High School students rotating shapes in GeoGebra with touchscreen. *Quaderni di Ricerca in Didattica*, 25, 103–108.
- Bairral, M. A., Assis, A., & da Silva, B. C. C. (2015b). Uma matemática na ponta dos dedos com dispositivos touchscreen. *RBECT*, 8(4), 39–74. <https://doi.org/10.3895/rbect.v8n4.1754>
- Bairral, M., Arzarello, F., & Assis, A. (2017). Domains of manipulation in touchscreen devices and some didactic, cognitive and epistemological implications for improving geometric thinking. In G. Aldon, F. Hitt, L. Bazzini, & U. Gellert (Eds.), *Mathematics and technology: A C.I.E.A.E.M source book* (pp. 113–142). Springer.
- Bairral, M., Henrique, M. P., & Assis, A. (2022). moving parallel and transversal lines with touches on smartphones: A look through screenrecording. *The Mathematics Enthusiast*, 19(1), 114–135.
- Baki, A. (2014). *Matematik tarihi ve felsefesi*. Pegem Akademi Yayinlicilik.
- Bakker, A., & Gravemeijer, K. (2006). An historical phenomenology of mean and median. *Educational Studies in Mathematics*, 62, 149–168.
- Bakker, A., & Wagner, D. (2020). Pandemic: Lessons for today and tomorrow? *Educational Studies in Mathematics*, 104(1), 1–4.
- Bakker, A., Cai, J., & Zenger, L. (2021). Future themes of mathematics education research: An international survey before and during the pandemic. *Educational Studies in Mathematics*. <https://doi.org/10.1007/s10649-021-10049-w>
- Balanskat, A., Blamire, R., & Kefala, S. (2006). The ICT impact report. *European Schoolnet*, 1, 1–71.
- Balbuena, L., De la Coba, D., & Garcia, E. (2000). Calados canarios y matemáticas. *Suma*, 35, 5–14.
- Ball, D. L. (1993). With an eye on the mathematical horizon: Dilemmas of teaching elementary school mathematics. *The Elementary School Journal*, 93(4), 373–397. <https://doi.org/10.1086/461730>
- Ball, D. L., Thames, M. H., & Phelps, G. (2008). Content knowledge for teaching: What makes it special. *Journal of Teacher Education*, 59(5), 389–407. <https://doi.org/10.1177/0022487108324>
- Balsiger, P. W. (2004). Supradisciplinary research practices: History, objectives and rationale. *Futures*, 36, 407–421.
- Banilower, E. R., Smith, P. S., Malzahn, K. A., Plumley, C. L., Gordon, E. M., & Hayes, M. L. (2018). *Report of the 2018 NSSME+*. Retrieved from <https://eric.ed.gov/?id=ED598121>
- Baran, E., Chuang, H., & Thompson, A. (2011, October). TPACK: An emerging research and development tool for teacher educators. *TOJET: The Turkish Online Journal of Educational Technology*, 10(4), 370–377.
- Baranauskas, M. C. C. (1993a). Uma abordagem Construcionista ao Design de um Ambiente para Programação em Lógica. In J. A. Valente (org.). *Computadores e conhecimento: repensando a educação* (pp. 313–330). UNICAMP/NIED.
- Baranauskas, M. C. C. (1993b). Procedimento, função, objeto ou lógica? Linguagens de programação vistas pelos seus paradigmas. In J. A. Valente (org.). *Computadores e Conhecimento: repensando a educação* (pp. 55–76). UNICAMP/NIED.
- Barbé, J., Bosch, M., Espinoza, L., & Gascón, J. (2005). Didactic restrictions on the teacher's practice: The case of limits of functions in Spanish high schools. In C. Laborde, M.-J. Perrin-Glorian, & A. Sierpiska (Eds.), *Beyond the apparent banality of the mathematics classroom* (pp. 235–268). Springer.
- Barbin, E. (1996). The role of problems in the history and teaching of mathematics. In R. Calinger (Ed.), *Vita Matemática. Historical research and integration with teaching*. MAA Notes. No. 40 (pp. 17–25).

- Barbin, É. (1997a). Histoire et enseignement des mathématiques : Pourquoi? Comment? *Bulletin de l'Association mathématique du Québec*, 37(1), 20–25.
- Barbin, E. (1997b). Historie et enseignement des mathématiques: pourquoi? Comment? (History and mathematics teaching: why? how?). *Bulletin de l'AMQ (Association Mathématique du Québec)*, XXXVII(1), 20–25.
- Barbin, E. (2006). Apport de l'histoire des mathématiques et de l'histoire des sciences dans l'enseignement [History of mathematics and history of sciences' contributions in the teaching]. *Tréma*, 26(1), 20–28.
- Barbin, É. (2012a). L'histoire des mathématiques dans la formation : Une perspective historique (1975–2010). In J.-L. Dorier & S. Coutat (Eds.), *Acte du congrès de l'Espace mathématiques francophone 2012* (pp. 546–554). University of Genève.
- Barbin, E. (2012b). L'histoire des mathématiques dans la formation: Une perspective historique (1975–2010) [History of mathematics in the teaching: A historical perspective (1975–2010)]. In J. L. Dorier & S. Coutat (Eds.), *Acte du congrès de l'EMF 2012* (pp. 546–554). University of Geneva.
- Barbin, É. (2022). On the role and scope of historical knowledge in using the history of mathematics in education. *ZDM Mathematics Education.*, 54, 1597–1611. <https://doi.org/10.1007/s11858-022-01410-1>
- Barbin, E., Bkouche, R., Bühler, M., Friedelmeyer, J. P., Guillemot, M., Hallez, M., Jozeau, M., Kahn, C., & Plane, H. (1996). *Pour une perspective historique dans l'enseignement des mathématiques*. Bulletin Inter-IREM épistémologie.
- Barbin, E., Bagni, G., Grugnetti, L., & Krofener, M. (2000). Integrating history: Research perspective. In J. Fauvel & J. Maanen (Eds.), *History in mathematics education – The ICMI study* (pp. 63–90). Kluwer.
- Barbin, E., Jankvist, U. T., & Kjeldsen, T. H. (2015). *Proceedings of the eighth European Summer University on history and epistemology in mathematics education ESU 7*. Aarhus University.
- Barbin, E., et al. (2018). *Let history into de mathematics classroom*. Springer.
- Barbin, E., Jankvist, U. T., Kjeldsen, T. H., Smestad, B., & Tzanakis, C. (2019). *Proceedings of the eighth European Summer University on history and epistemology in mathematics education ESU 8*. OsloMet.
- Barbin, É., Guillemette, D., & Tzanakis, C. (2020a). History of mathematics and education. In S. Lerman (Ed.), *Encyclopedia of mathematics education* (2nd ed., online). Springer. [https://doi.org/10.1007/978-3-030-15789-0\\_69](https://doi.org/10.1007/978-3-030-15789-0_69)
- Barbin, E., Guillemette, D., & Tzanakis, C. (2020b). History of mathematics and education. In S. Lerman (Ed.), *Encyclopedia of mathematics education* (2nd ed., pp. 333–342). Springer reference.
- Barrett, J. E., Sarama, J., Clements, D. H., Cullen, C., McCool, J., Witkowski-Rumsey, C., et al. (2012). Evaluating and improving a learning trajectory for linear measurement in elementary grades 2 and 3: A longitudinal study. *Mathematical Thinking and Learning*, 14(1), 28–54. <https://doi.org/10.1080/10986065.2012.625075>
- Bartolini Bussi, M. (1996). Mathematical discussion and perspective drawing in primary school. *Educational Studies in Mathematics*, 31, 11–41. <https://doi.org/10.1007/BF00143925>
- Bartolini Bussi, M. (2000). Ancient instruments in the modern classroom. In J. Fauvel & J. Maanen (Eds.), *History in mathematics education: The ICMI study* (pp. 343–350). Kluwer Academic publishers.
- Bartolini Bussi, M. G., & Mariotti, M. A. (2008). Semiotic mediation in the mathematics classroom: Artefacts and signs after a Vygotskian perspective. In L. English, M. Bartolini Bussi, G. Jones, R. Lesh, & D. Tirosh (Eds.), *Handbook of international research in mathematics education* (2nd ed., pp. 746–805). Lawrence Erlbaum.
- Bartolini Bussi, M. G., Boni, M., & Ferri, F. (1995). *Interazione sociale e conoscenza a scuola: la discussione matematica*. Comune di Modena.
- Bartolini Bussi, M. G., Ramploud, A., & Baccaglini-Frank, A. (2013). *Aritmetica in pratica*. Strumenti e strategie dalla tradizione cinese per l'inizio della scuola primaria, Erickson.

- Barton, B. (1995). Making sense of ethnomathematics: Ethnomathematics is making sense. *Educational Studies in Mathematics*, 31(1–2), 201–233.
- Barton, B. (1996). Anthropological perspectives on mathematics and mathematics education. In A. J. Bishop et al. (Eds.), *International handbook of mathematics education* (pp. 1035–1053). Springer.
- Barwell, R. et al. (Eds.) (2016). *Mathematics Education and Language Diversity. The 21st ICMI Study*. Springer. <https://link.springer.com/book/10.1007/978-3-319-14511-2>
- Bazin, M., & Tamez, M. (2002). *Math and science across cultures: Activities and investigations from the Exploratorium*. The New Press.
- BBC. (1993). *Fermat's Last Theorem – The theorem and its proof*. Film retrieved May 2022 from <<https://www.youtube.com/watch?v=6ymTZEeTjI8>>
- Beeley, P., Nasifoglu, Y., & Wardhaugh, B. (2020). *Reading mathematics in early modern Europe*. Routledge. <https://doi.org/10.4324/9781003102557>
- Benacka, J. (2016). Calculating ellipse area by the Monte Carlo method and analysing dice poker with excel at high school. *International Journal of Mathematics Education and Science and Technology*, 47(6), 976–986.
- Berggren, J. L. (2017). *Episodes in the mathematics of medieval Islam*. Springer. ISBN 978-1493937783.
- Berners-Lee, T., & Caillau, R. (1990). *Proposal for a Hyper Text Project, Internal proposal in the CERN*. Retrieved the 16th of June 2022 at [http://cds.cern.ch/record/2639699/files/Proposal\\_Nov-1990.pdf](http://cds.cern.ch/record/2639699/files/Proposal_Nov-1990.pdf)
- Berrío Londoño, K. (2009). *La medida en un contexto de escuela indígena. El caso de la comunidad tule y el caso de la comunidad Ember-Chami*. Trabajo de Grado no publicado, Universidad de Antioquia.
- Berry, J. (1994). *The international DERIVE Journal* (Vol. 1, p. 1). Ellis Horwood Limited.
- Berube, C. T. (2014). *STEM and the city: A report on STEM education in the great American urban public school system*. Information Age Publishing.
- Besalú, X. (2002). Educación intercultural. En, *Diversidad Cultural y Educación*. THE. Ed. Síntesis.
- Betz, N. E., & Hackett, G. (1983). The relationship of mathematics self-efficacy expectations to the selection of science-based college majors. *Journal of Vocational Behavior*, 23, 329–345.
- Bevan, R. (2001). Boys, girls and mathematics: Beginning to learn from the gender debate. *Mathematics in School*, 30(4), 2–6.
- Bielaczyc, K., & Collins, A. (1999). Learning communities in classrooms: A reconceptualization of educational practice. In C. M. Reigeluth (Ed.), *Instructional-Design Theories and models. A new paradigm of instructional theory* (pp. 269–292).
- Bini, G., & Robutti, O. (2019). Meanings in mathematics: Using internet memes and augmented reality to promote mathematical discourse. In U. T. Jankvist, M. van den Heuvel-Panhuizen, & M. Veldhuis (Eds.), *Proceedings of the eleventh congress of the European society for research in mathematics education*. Freudenthal Group & Freudenthal Institute, Utrecht University and ERME. <https://hal.archives-ouvertes.fr/hal-02422152>
- Bini, G., & Robutti, O. (2020). Is this the real life? Connecting mathematics across cultures. In *Proceedings of the CIEAEM 71 conference, Quaderni di Ricerca in Didattica (mathematics)*, 7. G.R.I.M. (Dipartimento di Matematica e Informatica, University of Palermo, Italy). [http://math.unipa.it/~grim/quaderno\\_2020\\_numspeg\\_7.htm](http://math.unipa.it/~grim/quaderno_2020_numspeg_7.htm)
- Bini, G., Robutti, O., & Bikner-Ahsbabs, A. (2020). Maths in the time of social media: Conceptualizing the internet phenomenon of mathematical memes. *International Journal of Mathematical Education in Science and Technology*. <https://doi.org/10.1080/0020739X.2020.1807069>
- Bishop, A. J. (1988). Mathematics education in its cultural context. *Educational Studies in Mathematics*, 19(2), 179–191.

- Bittar, M. (2010). A Incorporação de um Software em uma Sala de Matemática: uma análise segundo a abordagem instrumental. In A. P. Jahn & N. S. G. Allevalo (Org.). *Tecnologias e Educação Matemática: ensino, aprendizagem e formação de professores* (1ªed, Vol. 7, p. 209–225). SBEM.
- Black, P., & Wiliam, D. (2009). Developing the theory of formative assessment. *Educational Assessment, Evaluation and Accountability*, 21(1), 5–31.
- Blanco, L., Carrasco, A. C., & Guerrero, E. (2009). El dominio afectivo en la construcción del conocimiento didáctico del contenido sobre resolución de problemas de matemáticas. *Enseñanza de las ciencias*, Extra, 362–365.
- Blanco, L., Carrasco, A. C., Piedehierro, A., Guerrero, E., & del Amo, R. G. (2010). El Dominio afectivo en la Enseñanza/Aprendizaje de las Matemáticas. Una revisión de investigaciones locales. *Campo Abierto Revista de Educación*, 29(1), 13–31.
- Blanco-Álvarez, H. (2006). La Etnomatemática en Colombia. Un programa en construcción. *Revista Bolema: Boletim de Educação Matemática*, 19(26), 49–75.
- Blanco-Álvarez, H. (2011). La postura sociocultural de la educación matemática y sus implicaciones en la escuela. *Revista Educación y Pedagogía*, 23(59), 59–66.
- Blanco-Álvarez, H. (2012). Estudio de las actitudes hacia una postura sociocultural y política de la Educación Matemática en maestros en formación inicial. *REDIMAT – Journal of Research in Mathematics Education*, 1(1), 57–78.
- Blanco-Álvarez, H., Higuera Ramírez, C., & Oliveras, M. L. (2014). Una mirada a la Etnomatemática y la Educación Matemática en Colombia: caminos recorridos. *Revista Latinoamericana de Etnomatemática*, 7(2), 245–269.
- Blanton, M., & Kaput, J. (2005). Characterizing a classroom practice that promotes algebraic reasoning. *Journal for Research in Mathematics Education*, 36(5), 412–446.
- Blikstein, P. (2008). *O pensamento computacional e a reinvenção do computador na educação*. [http://www.blikstein.com/paulo/documents/online/ol\\_pensamento\\_computacional.html](http://www.blikstein.com/paulo/documents/online/ol_pensamento_computacional.html).
- Blikstein, P. (2013). Digital fabrication and “making” in education: The democratization of invention. In J. Walter-Herrmann & C. Büching (Eds.), *FabLabs: Of machines, makers and inventors* (pp. 1–21). Transcript Publishers.
- Blomeke, S., Gustafsson, J. E., & Shavelson, R. (2015). Beyond dichotomies: Competence viewed as a continuum. *Zeitschrift für Psychologie*, 223(1), 3–13. <https://doi.org/10.1027/2151-2604/a000194>
- Blomhøj, M. (2004). Mathematical modelling – a theory for practice. In B. Clarke, D. Clarke, G. Emanuelsson, B. Johnansson, D. Lambdin, F. Lester, A. Walby, & K. Walby (Eds.), *International perspectives on Learning and teaching mathematics* (pp. 145–159). National Center for Mathematics Education.
- Blom, B. S., & Broder, L. J. (1950). *Problem-solving processes of college students*. University of Chicago Press.
- Boero, P. (Ed.). (2007). *Theorems in school: From history, epistemology and cognition to classroom practice*. Sense Publishers.
- Boero, P., & Garuti, R. (1994). Approaching rational geometry: From physical relationships to conditional statements. In *Proceedings of PME-XVIII* (Vol. 2, pp. 96–103). PME.
- Boero, P., & Guala, E. (2008a). Development of mathematical knowledge and beliefs of teachers: The role of cultural analysis of the content to be taught. In P. Sullivan & T. Wood (Eds.), *The international handbook of mathematics teacher education* (Vol. 1, pp. 223–244). Sense.
- Boero, P., & Guala, E. (2008b). Development of mathematical knowledge and beliefs of teachers: The role of cultural analysis of the content to be taught. In P. Sullivan & T. Wood (Eds.), *The international handbook of mathematics teacher education, Volume I: Knowledge and beliefs in mathematics teaching and teaching development* (pp. 223–244). Sense.
- Boero, P., Pedemonte, B., & Robotti, E. (1997). Approaching theoretical knowledge through voices and echoes: A Vygotskian perspective. In *Proceedings of the PME 21* (pp. 81–89). PME.



- Bonilla, M. C., Milton, R., Auccahuallpa, R., & Reyes, M. E. (2018). *La dimensión matemática en educación intercultural bilingüe: educación matemática y diversidad*. APINEMA (Asociación Peruana de Investigación en Educación Matemática), Universidad de Federal de Ouro Preto, Universidad Nacional de Educación, Complejo Educacional Consolidada (Vol. 31, N° 2). Acta Latino americana de Matemática Educativa. ALME). <https://www.alme.org.mx/alme32v1/index.php>, [https://etnomatematica.org/home/wp-content/uploads/2021/06/LA-DIMENSION-MATEMATICA-EN-EDUCACION-INTERCULTURAL-BILINGUE\\_EDUCACION-MATEMATICA-Y-DIVERSIDAD.pdf](https://etnomatematica.org/home/wp-content/uploads/2021/06/LA-DIMENSION-MATEMATICA-EN-EDUCACION-INTERCULTURAL-BILINGUE_EDUCACION-MATEMATICA-Y-DIVERSIDAD.pdf)
- Borba, M. d. C., & Penteadó, M. G. (2007). *Informática e Educação Matemática (5ª edição)*. Autêntica.
- Borba, M. C., & Villarreal, M. E. (2006). *Humans-with-media and the reorganization of mathematical thinking: Information and communication technologies, modeling, visualization and experimentation* (Vol. 39). Springer Science & Business Media.
- Borba, M., Askar, P., Engelbrecht, J., Gadanidis, G., Llinares, S., & Sánchez-Aguilar, M. (2016). Blended learning, e-learning and mobile learning in mathematics education. *ZDM-Mathematics Education*, 48(5), 589–610. <https://doi.org/10.1007/s11858-016-0798-4>
- Borko, H., & Potari, D. (2020). *ICMI study 25. Teachers of mathematics working and learning in collaborative groups*. University of Lisbon.
- Bosch, M., et al. (Eds.). (2011). *Un panorama de la TAD. An overview of ATD*. CRM. <http://www.recercat.net/bitstream/handle/2072/200617/Documents10.pdf?sequence=1/41>
- Bosch, M., Gascón, J., & Trigueros, M. (2017). Dialogue between theories interpreted as research praxeologies: The case of APOS and the ATD. *Educational Studies in Mathematics*, 95(1), 39–52. <https://doi.org/10.1007/s10649-016-9734-3>
- Bourdieu, P. (1980). *Le sens pratique*. Éditions de Minuit.
- Boyer, C. (1968). *History of mathematics*. Wiley.
- Braathe, H. J. (2015). The new specialized Norwegian teacher education. *For the Learning of Mathematics*, 35(1), 39–41.
- Brackmann, C. P. (2017). *Desenvolvimento do pensamento computacional através de atividades desplugadas na educação básica*. Dissertation, Doctor in Informatics in Education. Universidade Federal do Rio Grande do Sul.
- Brasil. (2018). *Base Nacional Comum Curricular – BNCC*. Ministério da Educação.
- Breda, A. (2021). Valoración y rediseño de una unidad sobre proporcionalidad, utilizando la herramienta Idoneidad Didáctica. *Uniciencia*, 35(1), 38–54.
- Breda, A., Pino-Fan, L. R., & Font, V. (2017). Meta didactic-mathematical knowledge of teachers: Criteria for the reflection and assessment on teaching practice. *EURASIA Journal of Mathematics, Science and Technology Education*, 13(6), 1893–1918. <https://doi.org/10.12973/eurasia.2017.01207a>
- Breda, A., Font, V., & Pino-Fan, L. R. (2018). Criterios valorativos y normativos en la Didáctica de las Matemáticas: el caso del constructo idoneidad didáctica. *Bolema*, 32, 255–278.
- Bréhier, E. (1926). *Histoire de la Philosophie*. In. Presses Iniversitaires de France. Ed. F. Alcan. <https://archive.org/details/histoiredelaphil00br/page/6/mode/2up?ref=ol&view=theater>, [https://archive.org/stream/histoiredelaphil00br/histoiredelaphil00br\\_djvu.txt](https://archive.org/stream/histoiredelaphil00br/histoiredelaphil00br_djvu.txt), <https://ia802606.us.archive.org/5/items/histoiredelaphil00br/histoiredelaphil00br.pdf>
- Britannica. (2014). Diophantine equation. *The Editors of Encyclopaedia*. Encyclopedia Britannica, 26. <https://www.britannica.com/science/Diophantine-equation>
- Brito Prado, M. E. B., Lobo da Costa, N., & Mendonça Campos, T. M. (2015). Pedagogical use of tablets in mathematics teachers continued education. *Quaderni di Ricerca in Didattica (Mathematics)*, 25(2), 287–293.
- Briz, Á., & Serrano, Á. (2018). Aprendizaje de las matemáticas a través del lenguaje de programación R en Educación Secundaria. *Educación Matemática*, 30(1), 133–162. <https://doi.org/10.24844/em3001.05>

- Bronkhorst, L., & Akkerman, S. (2016). At the boundary of school: Continuity and discontinuity in learning across contexts. *Educational Research Review*, 19, 18–35. <https://doi.org/10.1016/j.edurev.2016.04.001>
- Bronner, A., et al. (Eds.). (2010). *Apports de la théorie anthropologique du didactique. Diffuser les mathématiques (et les autres savoirs) comme outils de connaissance et d'action*. IUFM.
- Brousseau, G. (1997). *Theory of didactical situations in mathematics*. Kluwer Academic Publishers.
- Brown, T., & McNamara, O. (2005). *New teacher identity and regulative government: The discursive formation of primary mathematics teacher education*. Springer.
- Brown, L., Fernández, C., Helliwell, T., & Llinares, S. (2020). Prospective mathematics teachers as learners in university and school contexts. In L. L. Gwendolyn & O. Chapman (Eds.), *International handbook of mathematics teacher education* (Vol. 3, pp. 343–366). Brill/Sense.
- Bruna, J. (2015). Do teacher's beliefs regarding the pupil's mistake influence willingness of pupils to solve difficult word problems? *Quaderni di Ricerca in Didattica (Mathematics)*, 25(2), 213–217.
- Bu, L., & Schoen, R. (2011). *Model-Centered Learning. Pathways to Mathematical Understanding Using GeoGebra*. SensePublishers. <https://doi.org/10.1007/978-94-6091-618-2>
- Bussi, M. G. B., & Mariotti, M. A. (2008). Semiotic mediation in the mathematics classroom: Artifacts and signs after a Vygotskian perspective. In *Handbook* (pp. 746–783).
- Busto, G. (1552). *Tractado subtilissimo de Arismetica y de Geometria... de nuevo emendado... por Gonçalo Busto*.
- Bütüner, S. O. (2018). Secondary school mathematics Teachers' knowledge levels and use of history of mathematics. *Journal of Education and Training Studies*, 6(1), 9–20. <https://doi.org/10.11114/jets.v6i1.2722>
- Buxton, L. (1981). *Do you panic about maths?* Heinemann.
- Byrne, O. (1847/2022). *The first six books of the elements of Euclid: In which coloured diagrams and symbols are used instead of letters for the greater ease of learners*. Taschen. ISBN: 978-3836577380.
- Cabrera-Baquedano, A., & Pezoa-Reyes, M. (2020, September). Relaciones entre subdominios del PCK: La experiencia de práctica comunitaria. In *IV Congreso iberoamericano sobre conocimiento especializado del profesor de matemáticas* (Vol. 225). Servicio de Publicaciones de la Universidad de Huelva.
- Cáceres, R., Cavero, O., & Gutiérrez, D. (2016). *Diagnóstico descriptivo de la situación de los pueblos originarios y de la política de Educación Intercultural Bilingüe en el Perú*. Ministerio de Educación.
- Cajori, F. (2007). A history of mathematical notations I (1928–29). Reprinted by Cosimo.
- Callejo, M. L., Pérez-Tyteca, P., Moreno, M., & Sánchez-Matamoros, G. (2021). The use of a length and measurement HLT by pre-service kindergarten teachers' to notice children's mathematical thinking. *International Journal of Science and Mathematics Education*, 20, 1–21. <https://doi.org/10.1007/s10763-021-10163-4>
- Campos, M. O. C. (1999). *Cabri-Géomètre: uma aventura epistemológica*. Thesis. Master in Education. Universidade Federal do Ceará – UFCE.
- Carbonell, F. (1998). *Minorities cultural (i lingüístiques) a l'escola ara i aquí. Condicionants sociopolítics i reptes educatius*. En Aznar, S., Buesa, S. y Terradellas, 33–34 M. R. (Coord.). Primer Simposi: Llengua, Educació i Immigració. Universitat de Girona.
- Carreño, E., & Climent, N. (2009). Polígonos: conocimiento especializado del contenido de estudiantes para profesor de matemáticas. In M. J. González, M. T. González, & J. Murillo (Eds.), *Investigación en Educación Matemática XIII* (pp. 187–196). SEIEM.
- Carreño, E., Rojas, N., Montes, M. A., & Flores, P. (2013). Mathematic Teacher's specialized knowledge. Reflections based on descriptors of knowledge. In *Proceedings of eighth ERME congress*.
- Carrillo, J., Climent, N., Contreras, L. C., & Muñoz-Catalán, M. C. (2013a). Mathematics teacher specialized knowledge. In *Proceedings of eighth ERME congress*.
- Carrillo, J., Climent, N., Contreras, L. C., & Muñoz-Catalán, M. C. (2013b). Determining specialized knowledge for mathematics teaching. In B. Ubuz, C. Haser, & M. A. Mariotti (Eds.),

- Proceedings of the VIII congress of the European Society for Research in mathematics education (CERME 8)* (pp. 2985–2994). Middle East Technical University.
- Carrillo, J., Climent, N., Montes, M., Contreras, L. C., Flores-Medrano, E., Escudero-Ávila, D., Vasco, D., Rojas, N., Flores, P., Aguilar-González, A., Ribeiro, M., & Muñoz-Catalán, M. C. (2018). The mathematics teacher's specialised knowledge (MTSK) model. *Research in Mathematics Education*, 20(3), 236–253. <https://doi.org/10.1080/14794802.2018.1479>
- Carrillo, J., Montes, M., Codes, M., Contreras, R. C., & Climent, N. (2019). El conocimiento didáctico del contenido del formador de profesores de matemáticas: su construcción a partir del análisis del conocimiento especializado pretendido en el futuro profesor. In F. Imbernón, A. S. Neto, & I. Fortunato (Eds.), *Formação permanente de professores: experiências iberoamericanas* (pp. 324–341). Edições Hipótese.
- Castro, J. (2007). *La investigación en educación matemática: una hipótesis de trabajo*. EDUCERE Investigación arbitrada. Vol. 11, N° 38, 201–230. Universidad de Los Andes.
- Castro, A. L. (2011). *Tecnologias Digitais de Informação e Comunicação e o Ensino de Funções Quadráticas: contribuições para a compreensão das diferentes representações*. Dissertação (Educação Matemática). Universidade Bandeirante de São Paulo.
- Cerda, T. (1758). *Liciones de mathematica, o elementos generales de arithmetia y algebra para el uso de la clase. Tomo 1*. Francisco Suria.
- Chace, A. B., Manning, H. P., & Archibald, R. C. (1927). *The Rhind mathematical papyrus. Photographic facsimile, hieroglyphic transcription, transliteration, literal translation, free translation, mathematical commentary, and bibliography* (Vol. 1). Mathematical Association of America – via Internet Archive.
- Champan, S. (1942). Blaise Pascal (1623-1662). *Nature*, 150, 508–509.
- Chao, T., Murray, E., & Star, J. (2016). Helping mathematics teachers develop noticing skills: Utilizing smartphone technology for one-on-one teacher/student interviews. *Contemporary Issues in Technology and Teacher Education*, 16(1), 22–37.
- Charalambous, C. Y., Panaoura, A., & Philippou, G. (2009). Using the history of mathematics to induce changes in preservice teachers' beliefs and attitudes: Insights from evaluating a teacher education program. *Educational Studies in Mathematics*, 71, 161–180. <https://doi.org/10.1007/s10649-008-9170-0>
- Charbonneau, C. (2002). La trigonométrie : une histoire à l'envers tournée d'abord vers le ciel. In I. L. Jeneau & S. Viau (Eds.), *Actes du 44<sup>e</sup> congrès annuel de l'AMQ* (pp. 47–56). Le Griffon d'Argile.
- Charle, C., & Verger, J. (2015). *Histoire des universités, XIIe-XXIe siècle*. PUF.
- Charles, R., & Lester, F. (1986). *Mathematical problem solving*. Learning Institute.
- Chartier, R. (1987). *The cultural uses of print in early modern France*. Princeton.
- Chavey, D. (2009). *Mathematical experiments with African Sona Designs. Bridges 2009: Mathematics, music, art, architecture, culture* (pp. 305–308).
- Chesky, N., & Wolfmeyer, M. (2015). *Philosophy of STEM education: A critical investigation*. Palgrave Macmillan. <https://doi.org/10.1057/9781137535467.0006>
- Chevallard, Y. (1991). *La transposition didactique – Du savoir savant au savoir enseigné*. La pensée sauvage.
- Chevallard, Y. (2006). Steps towards a new epistemology in mathematics education. In M. Bosch (Ed.), *Proceedings of CERME 4* (pp. 21–30). Fundemi IQS.
- Chevallard, Y. (2007). Readjusting didactics to a changing epistemology. *European Educational Research Journal*, 6(2), 131–134.
- Chevallard, Y., & Sensevy, G. (2014). Anthropological approaches in mathematics education, French perspectives. In *Encyclopedia of mathematics education* (pp. 38–43).
- Chorlay, R. (2016). Historical sources in the classroom and their educational effects. In L. Radford, F. Furinghetti, & T. Hausberger (Eds.), *Proceedings of the 2016 ICME satellite meeting of the international study group on the relations between the history and pedagogy of mathematics* (pp. 5–24). IREM de Montpellier.

- Chorlay, R., Clark, K. M., & Tzanakis, C. (2022). History of mathematics in mathematics education: Recent developments in the field. *ZDM Mathematics Education*, 54, 1407–1420. <https://doi.org/10.1007/s11858-022-01442-7>
- Christianidis, J., & Megreми, A. (2019). Tracing the early history of algebra: Testimonies on Diophantus in the Greek-speaking world (4th–7th century CE). *Historia Mathematica*, 47, 16–38. <https://doi.org/10.1016/j.hm.2019.02.002>
- Chronaki, A. (2005). Learning about ‘learning identities’ in the school arithmetic practice: The experience of two young minority Gypsy girls in the Greek context of education. *European Journal of Psychology of Education*, 20(1), 61–74.
- CIEAEM. (2000). *50 years of CIEAEM: where we are and where we go: “manifesto 2000 for the year of mathematics”*. [https://www.cieaem.org/images/Documents/CIEAEM\\_Manifesto/CIEAEM\\_Manifesto.pdf](https://www.cieaem.org/images/Documents/CIEAEM_Manifesto/CIEAEM_Manifesto.pdf). Accessed 16 May 2022.
- CIEAEM 70. (2018). *Mathematics and living together: Why, how, what?* <https://www.cieaem.org/index.php/en/meetings-en/2018-mostaganem-en>
- Cifoletti, G. C. (2021). “New” early modern evidence for Jacob Klein’s theses. In B. Hopkins & J. Drummond (Eds.), *The new yearbook for phenomenology and phenomenological philosophy* (Special Issue: Gian-Carlo Rota and The End of Objectivity, 2019). Routledge. <https://doi.org/10.4324/9781003131250>
- Filleruelo, J. (2000). La conjetura de Goldbach. *Gaceta de la Real Sociedad Matemática Española*, 3(3), 557–565. <https://eudml.org/doc/43270>
- Ciro, R. D. H., & Torres, M. M. (2016). Lo emocional como articulador de la razonabilidad en la didáctica de la matemática. *INGE@UAN-Tendencias en la ingeniería*, 8(16), 26–34.
- Civil, M., & Kahn, L. (2001). Mathematics instruction developed from a garden theme. *Teaching Children Mathematics*, 7(7), 400–405.
- Claireaut, A.-C. (1741). *Éléments de Géométrie*. Académie Royale des Sciences et de la Société Royale de Londres. Chez David Fils. <https://archive.org/details/elemensdegeomet00claigoog/page/n6/mode/2up>
- Clark, K. M. (2012). History of mathematics: Illuminating understanding of school mathematics concepts for prospective mathematics teachers. *Educational Studies in Mathematics*, 81, 67–84. <https://doi.org/10.1007/s10649-011-9361-y>
- Clark, K. (2019a). History and pedagogy of mathematics in mathematics education: History of the field, the potential of current examples, and directions for the future. In U. T. Jankvist, M. Heuvel-Panhuizen, & M. Veldhuis (Eds.), *Eleventh congress of the European Society for Research in mathematics education* (pp. 29–55). Utrecht University and ERME.
- Clark, K. (2019b). History and pedagogy of mathematics in mathematics education: History of the field, the potential of current examples, and directions for the future. In *Eleventh congress of the European Society for Research in mathematics education*. Utrecht University, Feb 2019.
- Clark, K. (2020). History and pedagogy of mathematics in mathematics education: History of the field, the potential of current examples, and directions for the future. In *Eleventh congress of the European Society for Research in mathematics education*, Utrecht University, Feb 2019, (hal-02436281). Utrecht, Netherlands.
- Clark, W., Logan, K., Luckin, R., Mee, A., & Oliver, M. (2009). Beyond web 2.0: Mapping the technology landscapes of young learners. *Journal of Computer Assisted Learning*, 25, 56–69. <https://doi.org/10.1111/j.1365-2729.2008.00305.x>
- Clark, K., Kjeldsen, T. H., Schorcht, S., Tzanakis, C., & Wang, X. (2016a). History of mathematics in mathematics education: Recent developments. In L. Radford, F. Furinghetti, & T. Hausberger (Eds.), *Proceedings of the 2016 meeting of the international study group on the relations between the history and pedagogy of mathematics* (pp. 135–179). IREM de Montpellier.
- Clark, K., Kjeldsen, T., Schorcht, S., & Tzanakis, C. (2016b). History of mathematics in mathematics education: Recent developments. In L. Radford, F. Furinghetti, & T. Hausberger (Eds.), *Proceedings of the 2016 ICME satellite meeting of the international study group on the relations between the history and pedagogy of mathematics* (pp. 135–179). IREM.

- Clark, K., et al. (2016c). *History of mathematics in mathematics education. Recent developments*. History and Pedagogy of Mathematics. <https://hal.archives-ouvertes.fr/hal-01349230>
- Clark, K., Kjeldsen, T. H., Schorcht, S., Tzanakis, C., & Wang, X. (2016d). *History of mathematics in mathematics education: Recent developments* (pp. 1–42). [https://www.academia.edu/26341958/History\\_of\\_Mathematics\\_in\\_Mathematics\\_Education:\\_Recent\\_developments](https://www.academia.edu/26341958/History_of_Mathematics_in_Mathematics_Education:_Recent_developments)
- Clark, K. M., Kjeldsen, T. H., Schorcht, S., & Tzanakis, C. (Eds.). (2018). *Mathematics, education and history. Towards a harmonious partnership. ICME-13 monographs*. Springer.
- Clark, K., Kjeldsen, T. H., Schorcht, S., & Tzanakis, C. (2019). History of mathematics in mathematics education – an overview. *Mathematica didactica*, 42, 1–26.
- Clark, K., et al. (2020). *History of mathematics in mathematics education: Recent developments*. <https://hal.archives-ouvertes.fr/hal-01349230/document>
- Clark-Wilson, A., Robutti, O., & Thomas, M. (2020). Teaching with digital technology. *ZDM*, 52, 1223–1242.
- Cobb, P. (1994). Where is the mind? Constructivist and sociocultural perspectives on mathematical development. *Educational Researcher*, 23(7), 13–20.
- Cofunded by Erasmus. (2021). *Programme of the European Unión*. <https://eaea.org/wp-content/uploads/2021/02/Bildung-spanish.pdf>
- Cohen, C. (2005). The influence of spatial ability on the use of a dynamic interactive animation in a spatial problem solving task. In T. Barkowsky, C. Freksa, M. Hegarty, & R. Lowe (Eds.), *Reasoning with mental and external diagrams. Computational modeling and spatial assistance*. American Association for Artificial Intelligence Press.
- Cole, M. (1996). *Psicología cultural*. The Belknap Press de Harvard University Press.
- Collet, C. G., & Itard, J. (1947). Un mathematician humaniste : Claude-Gaspar Bachet de Meziriac, 1581–1638. *Revue d'histoire des sciences*, 1, 26–50. <https://mathshistory.st-andrews.ac.uk/Biographies/Bachet/>
- Collette, J. P. (1985). *Historia de las matemáticas*. Siglo XXI.
- Colling, J., & Richit, A. (2019). Conhecimentos Pedagógico, Tecnológico e do Conteúdo na Formação Inicial do Professor de Matemática. *Educação Matemática Pesquisa*, 21(2), 394–421.
- Conde, J. (1782). *Rudimentos de algebra para facilitar la enseñanza de la Escuela Patriótica de la Real Sociedad Aragonesa de Amigos del Pais*. Blas Miedes.
- Conejo, A. (2008). *Educación Intercultural Bilingüe en el Ecuador, La propuesta educativa y su proceso* (pp. 64–82). Comunicación y Sociedad. <https://dspace.ups.edu.ec/bitstream/123456789/8090/1/Educaci%C3%B3n%20intercultural%20biling%C3%BCe%20en%20e1%20Ecuador.pdf>
- Contreras, J. I. Á., & Moreno, L. C. D. (2019). Emociones en Educación Matemática: una mirada con base en el pensamiento complejo. *Educação & Realidade*, 44, e76639.
- Contreras, L. C., Montes, M., Muñoz-Catalán, M. C., & Joglar, N. (2017). Fundamentos teóricos para conformar un modelo de conocimiento especializado del formador de profesores de matemáticas. In J. Carrillo & L. C. Contreras (Eds.), *Avances, utilidades y retos del modelo MTSK* (pp. 11–25). Actas de las III Jornadas del Seminario de Investigación de Didáctica de la Matemática de la Universidad de Huelva CGSE.
- Cooke, A. (2015, July). Preservice teacher conceptualization of mathematics. *Quaderni di Ricerca in Didattica (Mathematics)*, 25(2), 227–234.
- Cope, B., & Kalantzis, M. (Eds.). (1999). Introduction: Multiliteracies: The beginnings of an idea. In *Multiliteracies: Literacy learning and the design of social futures* (pp. 3–8). Taylor and Francis.
- Corica, A. R., & Otero, M. R. (2009). Analysis of a college mathematics praxeology with respect to the limit of functions and students' productions at the moment of assessment. *Revista latinoamericana de investigación en matemática educativa*, 12(3), 305–331.
- Cortázar, J. (1866). *Tratado de álgebra elemental*. Imprenta de Antonio Peñuelas.
- Cullen, T. A., & Guo, M. (2020). The nature of technology. In V. L. Akerson & G. A. Buck (Eds.), *Critical questions in STEM education* (pp. 21–32). Springer Nature. [https://doi.org/10.1007/978-3-030-57646-2\\_2](https://doi.org/10.1007/978-3-030-57646-2_2)

- D'Ambrosio, U. (1985). Ethnomathematics and its place in the history and pedagogy of mathematics. *For the Learning of Mathematics*, 5(1), 44–48.
- D'Ambrosio, U. (1986a). Sociocultural bases for mathematical education. In M. Carss (Ed.), *Proceedings of the fifth international congress on mathematical education* (pp. 1–6). Birkhäuser.
- D'Ambrosio, U. (1986b). *Da realidade à ação: reflexões sobre Educação e Matemática*. Summus.
- D'Ambrosio, U. (1997). Ethnomathematics and its place in the history and pedagogy of mathematics. In M. Fankenstein & A. Powell (Eds.), *Ethnomathematics: Challenging eurocentrism in mathematics education* (pp. 13–24). State University of New York Press.
- D'Ambrosio, U. (1998). *Etnomatemática*, 4.a ed., SãoPaulo, Ática.
- D'Ambrosio, U. (2001). *Etnomatemática: Elo entre las tradiciones e a modernidad*. Belo Horizonte.
- D'Ambrosio, U. (2002). Ethnomathematics: An overview. In M. de Monteiro (Ed.), *Proceedings of the second international congress on Ethnomathematics (ICEM2)* (pp. 4–7). Lyrium Comunacacao Ltda.
- D'Ambrosio, U. (2007). Peace, social justice and ethnomathematics. In B. Sriraman (Ed.), *International perspectives in social justice in mathematics education* (Monograph of the Montana Enthousiast) (pp. 25–34). The University of Montana and the Montana Council of Teachers of Mathematics.
- D'Ambrosio, U. (2011). Mathematicians, mathematics educators and the state of the world. *Quaderni di Ricerca in Didattica (Mathematics)*, 22(2), 25–36.
- Purificação, I. C. da. (1999). *Cabri-Géomètre e Teoria Van Hiele: possibilidades e avanços na construção do conceito de quadrilátero*. Thesis, Master in Education. Universidade Federal do Paraná – UFPR.
- Davidman, L., & Davidman, P. T. (1994). *Teaching with a multicultural perspective: A practical guide* (2nd ed.). California Polytechnic State University. [https://www.abebooks.com/servlet/BookDetailsPL?bi=30725392057&searchurl=an%3Ddavidman%2Bleonard%2Bdavidman%2Bpatricia%2Bt%26sortby%3D17&cm\\_sp=snippet-\\_srp1\\_-\\_title1](https://www.abebooks.com/servlet/BookDetailsPL?bi=30725392057&searchurl=an%3Ddavidman%2Bleonard%2Bdavidman%2Bpatricia%2Bt%26sortby%3D17&cm_sp=snippet-_srp1_-_title1)
- Davis, P. & Hersh, R. (1981). *The mathematical experience*. Birkhäuser.
- Davis, P., & Hersh, R. (1986). *Descartes' dream: The world according to mathematics*. Dover.
- Davis, R., Young, S., & McLoughlin, P. (1982). *The roles of "understanding" in the learning of mathematics*. Final report of the NSFG. Retrived 15th Feb., 2016 from <http://files.eric.ed.gov/fulltext/ED220279.pdf>
- de Abila, V. (n.d.-a). *Aplicación del Algebra a la regla de tres simple, directa, e indirecta; a la de tres compuesta; a la de compañías sin tiempo; y con el; al interes simple, al interes compuesto; y a las aligaciones*. Francisco Suria y Burgada.
- de Abila, V. (n.d.-b). *Elementos de Algebra, o sea reglas generales para encontrar lo que vale la incognita en las equaciones de el primero, y segundo grado, en quienes no haya termino irracional, y resolucion de setenta y quatro problemas, distribuido todo en veinte y tres Dia*. Francisco Suria y Burgada.
- de Avila, V. (1780). *Reglas generales que de la arithmetica numerica y literal, de la formacion de potencias, y extraccion de raíces de cantidades numericas, y literales, y de la algebra*. Francisco Moreno.
- De Gamboa, G., Badillo, E., Ribeiro, M., Montes, M., & Sanchez-Matamoros, G. (2020). The role of teachers' knowledge in the use of learning opportunities triggered by mathematical connections. In S. Zehetmeier, D. Potari, & M. Ribeiro (Eds.), *Professional development and knowledge of mathematics teachers*. Routledge. <https://doi.org/10.4324/9781003008460>
- Guzman, M. de (1994). Impactos de la Matemática sobre la Cultura, en: *La Ciencia ante el siglo XXI. Ciclo de conferencias de la Real Academia de Ciencias Exactas, Físicas y Naturales (Fundación Ramón Areces, Madrid, 1995), 21–54*. (Texto de una conferencia en la Fundación Ramón Areces).
- De Guzmán, M. (2001a). *Tendencias actuales de la educación matemática*. Universidad Complutense de Madrid. *Rev. SIGMA-1* (pp. 5–25). <https://www.euskara.euskadi.eus/>

- [contenidos/informacion/dia6\\_sigma/eu\\_sigma/adjuntos/sigma\\_19/3\\_Educacion\\_Matematica.pdf](http://www.mdeguzman.net), <http://www.mdeguzman.net>
- De Guzmán, M. (2001b). *Tendencias actuales de la educación matemática*.
- De Lange, J., Keite, C., Huntley, I., & Niss, M. (1993). *Innovations in maths education by modelling and applications*. Ellis Horwood.
- de Ulloa, P. (1706). *Elementos mathematicos* (1st ed.). Antonio González de Reyes.
- Dean, J. (2008). *Ensenyar història a Primària*. Zenobita edicions.
- Delambre, M. (1988). *Composition mathématique de Claude Ptolémée ou astronomie ancienne*. Blanchard.
- Desforges, C. W., & Cockburn, A. D. (1987). *Understanding the mathematics teacher: A study of practice in the first school*. Falmer Press.
- Dewey, J. (1979). *Como pensamos – como se relaciona o pensamento reflexivo com o processo educativo: uma reexposição*. Editora Nacional.
- Dickenson-Jones, A. (2008). Transforming ethnomathematical ideas in western mathematics curriculum texts. *Mathematics Education Research Journal*, 20(3), 32–53. James Cook University.
- Díez-Palomar, J. (2004). *L'ensenyament de les matemàtiques en l'educació de persones adultes*. Tesis doctoral no publicada. Universitat de Barcelona.
- Díez-Palomar, J. (2020). Dialogic mathematics gatherings: Encouraging the other women's critical thinking on numeracy. *ZDM-Math Education*, 52(3), 473–487. <https://doi.org/10.1007/s11858-019-01092-2>
- Díez-Palomar, J., Gimenez, J., Vanegas, Y., & Font, V. (2014). Connecting mathematics to other disciplines as a meeting point for preservice teachers. *Quaderni di Ricerca in Didattica (Mathematics)*, 24(1), 94–97.
- Díez-Palomar, J., Vanegas, Y., Giménez, J., & Hummes, V. B. (2020). *Discussing 'lesson study' and 'didactical suitability criteria as tools designed for teacher collaboration in mathematics*. ICMI.
- Díez-Palomar, J., Chan, M. C. E., Clarke, D., & Padrós, M. (2021). How does dialogical talk promote student learning during small group work? An exploratory study. *Learning, Culture and Social Interaction*, 30, 100540. <https://doi.org/10.1016/j.lcsi.2021.100540>
- Dindyal, J., Schack, E. O., Choy, B. H., & Sherin, M. G. (2021). Exploring the terrains of mathematics teacher noticing. *ZDM-Mathematics Education*, 53, 1–16. <https://doi.org/10.1007/s11858-021-01249-y>
- Doolittle, E. (2007). Mathematics as medicine. In Liljedahl, P. (Ed.) *Proceedings of the 2006 Annual Meeting of the Canadian mathematics education study group* (30th, Calgary, Alberta, Canada, Jun 3-7, 2006). Canadian Mathematics Education Study Group. Retrieved May 2022 from < <https://eric.ed.gov/?id=ED529562>>
- Doorman, M., Drijvers, P., Gravemeijer, K., Boon, P., & Reed, H. (2013). Design research in mathematics education: The case of an ICT-rich learning arrangement for the concept of function. In T. Plomp & N. Nieveen (Eds.), *Educational design research – Part B: Illustrative cases* (pp. 425–446). SLO.
- Dori, Y. J., Tal, T., & Heyd-Metzuyanim, E. (2018). SWOT analysis of STEM education in academia: The disciplinary versus cross disciplinary conflict. In O. Hazzan, E. Heyd-Metzuyanim, A. Even-Hazav, T. Tal, & Y. J. Dori (Eds.), *Application of management theories for STEM education. The case of SWOT analysis* (pp. 25–41). Springer.
- Dorier, J. L., & Coutat, S. (2012). *Enseignement des mathématiques et contrat social: enjeux et défis pour le 21e siècle–Actes du colloque EMF2012*.
- Dossey, J. A., Mullis, J. V. S., Lindquist, M. M., & Chambers, D. L. (1988). *The mathematics report card: Trends and achievement based on the 1986 national assessment*. Educational Testing Service.
- Drijvers, P. (2003). *Learning algebra in a computer algebra environment: Design research on the understanding of the concept of parameter*. Dissertation. Utrecht, The Netherlands: CD-B Press.

- Drijvers, P. (2015). Digital technology in mathematics education: Why it works (or doesn't). In S. J. Cho (Ed.), *Selected regular lectures from the 12th international congress on mathematical education* (pp. 135–151). Springer.
- Drijvers, P., & Doorman, M. (1996). The graphics calculator in mathematics education. *The Journal of Mathematical Behavior*, 15(4), 425–440.
- Duarte, R. C. B. C. (2018). *Utilização do GeoGebra, de smartphone e de reflexões escritas na construção de conceitos relacionados a retas paralelas cortadas por uma transversal*. Master Dissertation. Seropédica: UFRRJ/PPGEduCIMAT.
- Duarte, R., & Bairral, M. (2021). Smartphone e GeoGebra: Um convívio não paralelo em sala de aula. In M. Bairral & M. P. Henrique (Eds.), *Smartphones com toques da Educação Matemática: Mãos que pensam, inovam, ensinam, aprendem e pesquisam* (pp. 65–100). CRV.
- Dubinsky, E., & Leron, U. (1994). *Learning abstract algebra with ISETL*. Springer.
- Dumont, B. (1988). New Technologies in Education for new access to information and new hierarchy of communication. In *Children in the information age* (pp. 179–187). Pergamon.
- Duval, R. (1988). Graphiques et équations: l'Articulation de deux registres. *Annales de Didactique et de Sciences Cognitives*, 1, 235–253.
- Duval, R. (1993). Registres de représentation sémiotique et fonctionnement cognitif de la pensée. *Annales de didactique et de sciences cognitives*, 5(1), 37–65.
- Duval, R. (1995). *Sémiosis et pensée humaine: Registres sémiotiques et apprentissages intellectuels*. Peter Lang.
- Dyrberg, N., & Holmegaard, H. T. (2019). Motivational patterns in STEM education: A self-determination perspective on first year courses. *Research in Science & Technological Education*, 37(1), 90–109.
- Eagle, R. (1995). *Mathematics through history*. Cambridge University Press.
- Eglash, R. (1997). When math worlds collide: Intention and invention in ethnomathematics. *Science, Technology, & Human Values*, 22(1), 79–97.
- Eglash, R. (1999). *African fractals: Modern computing and indigenous design*. Rutgers University Press.
- Engeström, Y. (1999). Activity theory and individual and social transformation. In Y. Engeström, R. Miettinen, & R.-L. Punamäki (Eds.), *Perspectives on activity theory* (pp. 19–38). Cambridge University Press.
- English, L. D. (2009). Promoting interdisciplinarity through mathematical modelling. *ZDM*, 41(1–2), 161–181.
- Erickson, F. (2012). Qualitative research methods for science education. In I. B. Fraser, K. Tobin, & C. McRobbie (Eds.), *Second international handbook of science education* (pp. 1451–1469). Springer.
- Ernest, P. (1986). Games. A rationale for their use in the teaching of mathematics in school. *Mathematics in School*, 15(1), 2–5.
- Ernest, P. (1995). Values, gender and images of mathematics: A philosophical perspective. *International Journal of Mathematical Education in Science and Technology*, 26(3), 449–462.
- Ernest, P. (1999). Forms of knowledge in mathematics and mathematics education: Philosophical and rhetorical perspectives. In D. Tirosh (Ed.), *Forms of mathematical knowledge* (pp. 67–83). Springer.
- Ernest, P. (2008). Epistemology plus values equals classroom image of mathematics. *Philosophy of Mathematics Education Journal*, 23, 1–12.
- Euclid. (s.f.). *Euclid's "Elements"*. Venice: Erhard Ratdolt, 1482-05-25.
- Euler, L. (1747). Theoremata circa divisores numerorum. *Novi Commentarii academiae scientiarum Petropolitanae*, 1, 20–48.
- Euler's Correspondence with Christian Goldbach. <https://eulerarchive.maa.org/correspondence/correspondents/Goldbach.html>
- Falbel, A. (1993). *What is Construcionism? LEGO Publication*.
- Fanon, F. (1952). *Black skin, white mask* (1986 Edition, with a foreword by H. Bhabha). Pluto Press.
- Fanon, F. (1961). Letter to the youth of Africa. In *Political essay, later published in toward the Africa revolution*. Grove Press.



- Farfán, R., & Sosa, L. (2007). Formación de profesores. Diversas concepciones que afectan el quehacer docente y competencias iniciales de profesores del nivel medio superior. In C. Crespo (Ed.), *Acta Latinoamericana de Matemática Educativa* (Vol. 20, pp. 347–352). Comité Latinoamericano de Matemática Educativa.
- Farmaki, V., & Paschos, T. (2007). Employing genetic ‘moments’ in the history of mathematics in classroom activities. *Educational Studies in Mathematics*, 66, 83–106.
- Fasheh, M. (2012). The role of mathematics in the destruction of communities, and what we can do to reverse this process, including using mathematics. In O. Skovsmose & B. Greer (Eds.), *Opening the cage: Critique and politics of mathematics education* (pp. 92–105). Brill.
- Fasheh, M., Abtahi, Y., & Chronaki, A. (2017). *Mujaawarah: Being together in wisdom or reclaiming life for mathematics*. In A. Chronaki (Ed.), *Proceedings of the ninth international mathematics education and society conference* (pp. 298–312). MES.
- Fauvel, J. (1991). Using history in mathematics education. *For the Learning of Mathematics*, 11(2), 3–6.
- Fauvel, J., & Gray, J. (1991). *The history of mathematics: A reader*. Open University.
- Fauvel, J., & van Maanen, J. (2000). *History in mathematics education. The ICMI study*. Kluwer Academic Publishers.
- Fauvel, J., & van Maanen, J. (Eds.). (2002). *History in mathematics education: The ICMI study*. Kluwer Academic Publishers. <https://doi.org/10.1007/0-306-47220-1>
- Favilli, F. (Ed.). (2007). *Ethnomathematics and mathematics education, Proceedings of the 10<sup>th</sup> International Congress of Mathematics Education, Discussion Group 15: Ethnomathematics*. Tipografia Editrice Pisana, Pisa.
- Fedorov, A. (2008). Media education around the world: Brief history. *Acta Didactica Napocensia*, 1(2), 56–68.
- Fennema, E., & Peterson, P. (1985). Autonomous learning behavior: A possible explanation of gender-related differences in mathematics. In L. C. Wilkinson & C. Marrett (Eds.), *Gender influences in classroom interaction* (pp. 17–35). Academic.
- Fernández, T., & Tamaro, E. (2004). Biografía de Diofanto de Alejandría. En *Biografías y Vidas. La enciclopedia biográfica en línea*. Barcelona, España. <https://www.biografiasyvidas.com/biografia/d/diofanto.htm>
- Ferrarello, D. (2015). Rescuing casualties of mathematics. *Quaderni di Ricerca in Didattica (Mathematics)*, 25(2), 235–243.
- Ferrarello, D., Floris, R., & Gimenez, J. (2015). Teacher education. *Quaderni di Ricerca in Didattica (Mathematics)*, 25(2), 203–204.
- Ferreira-Gauchía, C., Vilches, A., & Gil-Pérez, D. (2012). Teachers’ conceptions about the nature of technology and the science-technology-society-environment relationships. *Enseñanza de las Ciencias*, 30(2), 197–218. <https://doi.org/10.5565/rev/ec/v30n2.557>
- Feucht, F. C., Lunn Brownlee, J., & Schraw, G. (2017). Moving beyond reflection: Reflexivity and epistemic cognition in teaching and teacher education. *Educational Psychologist*, 52(4), 234–241. <https://doi.org/10.1080/00461520.2017.1350180>
- Firth, L., & Mellor, D. (2002). The importance of national ICT visions for information society in South East Asia. In *ACIS 2002 Proceedings*, 86.
- Fissore, C., Floris, F., Marchisio, M., & Sacchet, M. (2020, November). Maple for distance education in secondary schools during the COVID-19 emergency. In *Maple Conference* (pp. 204–218). Springer, Cham.
- FitzSimons, G., & Díez-Palomar, J. (2014). Mathematics and its teaching in relation to other disciplines. *Quaderni di Ricerca in Didattica (Mathematics)*, 24(1), 65–67.
- Flecha, R. (2011). Mathematics for social inclusion. *Quaderni di Ricerca in Didattica (Mathematics)*, 22(2), 51–55.
- Flecha, R. (2014). *Successful educational actions for inclusion and social cohesion in Europe*. Springer.
- Flores, E., Escudero, D. I., & Carrillo, J. (2013). A theoretical review of specialized content knowledge. In *Proceedings of eighth ERME congress*.

- Florio, E. (2020). A synergy between history of mathematics and mathematics education: A possible path from geometry to symbolic algebra. *Education Sciences*, 10(9), 243. <https://doi.org/10.3390/educsci10090243>
- Floris, R. (2015). Un dispositif de formation initiale pour l'intégration d'environnements numériques dans l'enseignement des mathématiques au secondaire. *Quaderni di Ricerca in Didattica (Mathematics)*, 25(2), 245–249.
- Font, V., Godino, J. D., & Gallardo, J. (2013). The emergence of objects from mathematical practices. *Educational Studies in Mathematics*, 82(1), 97–124. <https://doi.org/10.1007/s10649-012-9411-0>
- Forgasz, H. (1998). The “male domain” of high school and tertiary mathematics learning environments. In C. Keitel (Ed.), *Social justice and mathematics education: Gender, class, ethnicity and the politics of schooling* (pp. 32–44). International Organization of Women and Mathematics Education.
- Frankenstein, M. (1989). *Relearning mathematics: A different third R – Radical maths*. Free Association Books.
- Freire, P. (1997). *Pedagogía de la Autonomía: Saberes necesarios para la práctica educativa México, Siglo XXI*, 22–41. <https://redclade.org/wp-content/uploads/Pedagog%C3%ADa-de-la-Autonom%C3%ADa.pdf>
- Freire, P. (2000). *Pedagogia da autonomia: saberes necessários à prática educativa. 7 ed. São Paulo: Paz e Terra* (original de 1996).
- Frejd, P. (2013). Old algebra textbooks: A resource for modern teaching. *BSHM Bulletin: Journal of the British Society for the History of Mathematics*, 28(1), 25–36. <https://doi.org/10.1080/17498430.2012.676963>
- Freudenthal, H. (1968a). Why to teach mathematics so as to be useful. *Educational Studies in Mathematics*, 1(1/2), 3–8.
- Freudenthal, H. (1968b). Proceedings of the Colloquium “How to Teach Mathematics so as to Be Useful”. *Educational Studies in Mathematics*, 1, 1–2.
- Freudenthal, H. (1973a). *Mathematics as an educational task*. Reidel.
- Freudenthal, H. (1973b). *Mathematics as an educational task*. Springer.
- Freudenthal, H. (1981). Should a mathematics teacher know something about the history of mathematics? *For the learning of Mathematics*, 2(1), 30–33.
- Freudenthal, H. (1983a). *The didactic phenomenology of mathematical structures*. Reidel.
- Freudenthal, H. (1983b). Didactical phenomenology of mathematical structures. In *Mathematics Education Library*. D. Reidel Publishing Company.
- Freudenthal, H. (2002). *Revisiting mathematics education*. Kluwer.
- Fried, M. (2001). Can mathematics education and history of mathematics coexist? *Science & Education*, 10, 391–408.
- Fried, M. N. (2006). Mathematics as a constructive activity: Learners generating examples. *Zentralblatt für Didaktik der Mathematik*, 38, 209–211. <https://doi.org/10.1007/BF02655890>
- Fried, M. N. (2007). Didactics and history of mathematics: Knowledge and self-knowledge. *Educational Studies in Mathematics*, 66, 203–223. <https://doi.org/10.1007/s10649-006-9025-5>
- Fried, M. N. (2014). History of mathematics in mathematics education. In M. R. Matthews (Ed.), *International handbook of research in history, philosophy and science teaching* (pp. 669–703). Springer Science+Business Media. [https://doi.org/10.1007/978-94-007-7654-8\\_21](https://doi.org/10.1007/978-94-007-7654-8_21)
- Fried, M. N. (2018a). History of mathematics, mathematics education, and the liberal arts. In G. Kaiser, H. Forgasz, M. Graven, A. Kuzniak, E. Simmt, & B. Xu (Eds.), *Invited lectures from the 13th international congress on mathematical education. ICME-13 monographs*. Springer. [https://doi.org/10.1007/978-3-319-72170-5\\_6](https://doi.org/10.1007/978-3-319-72170-5_6)
- Fried, M. N. (2018b). History of mathematics, mathematics education, and the Liberal arts. In G. Kaiser et al. (Eds.), *Invited lectures from the 13th international congress on mathematical education (ICME-13 Monographs)*. Springer. [https://doi.org/10.1007/978-3-319-72170-5\\_6](https://doi.org/10.1007/978-3-319-72170-5_6)
- Fried, M. N., Guillemette, D., & Jahnke, H. N. (2016). Theoretical and/or conceptual frameworks for integrating history in mathematics education. In L. Radford, F. Furinghetti, & T. Hausberger

- (Eds.), *Proceedings of the 2016 ICME satellite meeting of the international study group on the relations between the history and pedagogy of mathematics* (pp. 211–230). IREM de Montpellier.
- Frykholm, J., & Glasson, G. (2005). Connecting science and mathematics instruction: Pedagogical context knowledge for teachers. *School Science and Mathematics*, 105(3), 127–141.
- Furinghetti, F. (2000). The history of mathematics as a coupling link between secondary and university teaching. *International Journal of Mathematical Education in Science and Technology*, 31, 43–51. <https://doi.org/10.1080/002073900287372>
- Furinghetti, F. (2007). Teachers education through the history of mathematics. *Educational Studies in Mathematics*, 66, 131–143. Special issue on the history of mathematics in mathematics education.
- Furinghetti, F. (2020). Rethinking history and epistemology in mathematics education. *International Journal of Mathematical Education in Science and Technology*, 51(6), 967–994.
- Furinghetti, F., & Menghini, M. (2014). The role of concrete materials in Emma Castelnuovo's view of mathematics teaching. *Educational Studies in Mathematics*, 87(1), 1–6. <https://doi.org/10.1007/s10649-014-9569-8>
- Furinghetti, F., & Somaglia, A. (1997). History of mathematics in school acrossdisciplines. *Mathematics in School*, 27(4), 48–51.
- Furinghetti, F., Jahnke, H., & van Maanen, J. (2006). Mini-workshop on studying original sources in mathematics education. *Oberwolfach Reports*, 3(2), 1285–1318.
- Furinghetti, F., Radford, L., Katz, V. (Eds.). (2007). *The history of mathematics in mathematics education: Theory and practice*. Educational Studies in Mathematics, 66(2), 107–271.
- Furinghetti, F., Menghini, M., Arzarello, F., & Giacardi, L. (2008). ICMI renaissance: The emergence of new issues in mathematics education. In M. Menghini, F. Furinghetti, L. Giacardi, & F. Arzarello (Eds.), *The first century of the international commission on mathematical instruction (1908–2008)* (pp. 131–147). Reflecting and shaping the world of mathematics education. Istituto della Enciclopedia Italiana.
- Fuss, P. H. (1843). Correspondance mathématique et physique de quelques célèbres géomètres du XVIIIème siècle, précédé d'une notice sur les travaux de Léonard Euler, tant imprimés qu'inédits et publiée sous les auspices de l'Académie impériale des sciences de Saint-Petersbourg. Ed. P. H. (Paul Heinrich), 1797–185. St.-Petersbourg [De l'impr. de l'Académie impériale des sciences]. Digitizing sponsor Google (2008). <https://archive.org/details/correspondancem01goldgoog/page/n75/mode/2up>
- Gadamer, H. G. (1991). *L'art de comprendre : Herméneutique et champ de l'expérience humaine*. Aubier.
- Gairín, J. (2005). Organizar la escuela intercultural una exigencia del futuro. Actas Congreso Iberoamericano de Pedagogía. Ed. Sociedad Española de Pedagogía. En Vol. 1. *La educación en contextos multiculturales. Diversidad e identidad*. Sec. IV. Instituciones y escenarios para un currículum multicultural conferencias, mesas redondas y talleres. 273, 329.
- García, F. X. (1733). *Arithmetica especulativa y practica y arte mayor o algebra*. Imprenta Real de Luis de Cueto.
- García, J. J. (1782). *Elementos de aritmetica, álgebra y geometría*. Joaquín Ibarra.
- García, J. A. (2008). Génesis histórica y enseñanza de las matemáticas. *Rev. UNIÓN. Número, 15*, 61–87.
- García, D. (2015). Jorge Juan: el introductor del Cálculo Infinitesimal en España. *Suma: Revista Sobre Enseñanza y Aprendizaje de Las Matemáticas*, 79, 53–63.
- García González, M. D. S., & Pascual Martín, M. I. (2017). De la congoja a la satisfacción: el conocimiento emocional del profesor de matemáticas. *Revista de investigación educativa de la REDIECH*, 8(15), 133–148.
- García Marimón, O., Diez-Palomar, J., Morales Maure, L., & Durán González, R. E. (2021). Evaluación de secuencias de aprendizaje de matemáticas usando la herramienta de los Criterios de Idoneidad Didáctica. *Bolema*, 35, 1047–1072.

- García-Carrión, R., López de Aguilera, G., Padrós, M., & Ramis-Salas, M. (2020a). Implications for social impact of dialogic teaching and learning. *Frontiers in Psychology, 11*, 140. <https://doi.org/10.3389/fpsyg.2020.00140>
- García-Carrión, R., Padrós Cuxart, M., Alvarez, P., & Flecha, A. (2020b). Teacher induction in schools as learning communities: Successful pathways to teachers' professional development in a diverse school serving students living in poverty. *Sustainability, 12*(17), 7146. <https://doi.org/10.3390/su12177146>
- García-González, M. S., Ramírez-Gómez, B., & Navarro-Sandoval, C. (2021). Situaciones que Originan Emociones en Estudiantes de Matemáticas. *Bolema, 35*, 39–62.
- Gates, P., & Jorgensen, R. (2009). Foregrounding social justice in mathematics teacher education. *Journal of Mathematics Teacher Education, 12*(3), 161–170. <https://doi.org/10.1007/s10857-009-9105-4>
- Gay, G. (2010). *Culturally responsive teaching: Theory, research, and practice* (2nd ed.). Teachers College Press.
- Geiger, V. (2016). Designing for mathematical applications and modelling tasks in technology rich environments. In A. Leung & A. Baccaglioni-Frank (Eds.), *Digital Technologies in Designing Mathematics Education Tasks, mathematics education in the digital era* (pp. 285–301). Springer International Publishing. [https://doi.org/10.1007/978-3-319-43423-0\\_14](https://doi.org/10.1007/978-3-319-43423-0_14)
- Geiger, V., Faragher, R., & Goos, M. (2010). CAS-enabled technologies as 'agents provocateurs' in teaching and learning mathematical modelling in secondary school classrooms. *Mathematics Education Research Journal, 22*(2), 48–68.
- Gellert, U., Barbé, J., & Espinoza, L. (2013a). Towards a local integration of theories: Codes and praxeologies in the case of computer-based instruction. *Educational Studies in Mathematics, 82*(2), 303–321. <https://doi.org/10.1007/s10649-012-9427-5>
- Gellert, U., Hernández, R., & Chapman, O. (2013b). Research methods in mathematics teacher education. In M. A. Clements, A. J. Bishop, C. Keitel, J. Kilpatrick, & F. K. S. Leung (Eds.), *Third international handbook of mathematics education* (pp. 327–360). Springer.
- Gerdes, P. (1988). On possible uses of traditional Angolan sand drawings in the mathematics classroom. *Educational Studies in Mathematics, 19*(1), 3–22.
- Gerdes, P. (1994). Reflections on Ethnomathematics. *For the Learning of Mathematics, 14*(2), 19–21.
- Gerdes, P. (1996). On ethnomathematics and the transmission of mathematical knowledge in and outside of schools in Africa south of the Sahara. In R. Waast (Ed.), *Les sciences hors d'Occident au XXème Siècle (Science et développement)* (Vol. 5, pp. 229–246). ORSTOM/UNESCO.
- Gerdes, P. (2004). *Plaited strip patterns on Tonga handbags in Inhambane*. <http://www.mi.sanu.ac.rs/vismath/gerdbook/gerdtongastrip/#421>
- Gerdes, P. (2007). *Etnomatemática: Reflexões sobre Matemática e Diversidade Cultural*. Portuga, Edições Húmus.
- Gerdes, P. (2014). Reflexões sobre o ensino da matemática e diversidade cultural. *Revista Latinoamericana de Etnomatemática, 7*(2), 108–118. <https://www.revista.etnomatematica.org/index.php/RevLatEm/article/view/124/328>
- Gerofsky, S. (2004). A man left Albuquerque heading east: Word problems as genre in mathematics education. Peter Lang. ISBN: 978-0820458236.
- Gerofsky, S. (2008). Mathematics education. In S. Mathison & W. Ross (Eds.), *Battleground schools*. : Greenwood, vol. 2, pp. 391–400. ISBN: 978-0313339424.
- Gerofsky, S. (2019). Approaching the history of mathematics via the performing arts: Kepler: A "renaissance folk play" in verse. *The Mathematical Intelligencer, 41*, 57–66.
- Gheverghese, J. G. (2000). *The crest of the peacock: The non-European roots of mathematics*. Londres. ISBN 0-691-00659-8 e ISBN 978-0-691-00659-8.
- Giacomone, B., Godino, J. D., & Beltrán-Pellicer, P. (2018). Developing the prospective mathematics teachers' didactical suitability analysis competence. *Educação e Pesquisa, 44*, e172011.
- Giannini, P. (1782). *Curso matematico para la enseñanza de los caballeros cadetes del Real Colegio Militar de Artillería. Tomo II*. Don Antonio Espinosa.

- Giannini, P. (1795). *Curso matematico para la enseñanza de los caballeros cadetes del Real Colegio Militar de Artillería. Tomo III*. Don Antonio Espinosa.
- Gil, P., & Martinho, M. H. (2015). The role of history of mathematics in fostering argumentation: Two towers, two birds and a fountain. In K. Krainer & N. Vondrová (Eds.), *Proceedings of the ninth congress of the European Society for Research in Mathematics Education* (pp. 1817–1824). Charles University in Prague, Faculty of Education and ERME.
- Gil, N., Guerrero, E., & Blanco, L. (2006). El dominio afectivo en el aprendizaje de las Matemáticas. *Electronic Journal of Research in Educational Psychology*, 4(1), 47–72.
- Giménez, J. (2020). Complexity with simplicity. *Quaderni di Ricerca in Didattica (Mathematics)*, 7(special issue), 43–54.
- Giménez, J., Font, V., & Vanegas, Y. (2013). Designing professional tasks for didactical analysis as a research process. Task Design in Mathematics Education. In *Proceedings of ICMI study* (Vol. 22, pp. 581–590).
- Gimenez, J., Vanegas, Y., & Díez-Palomar, J. (2019). Designing interdisciplinary learning units drawing on a research project aimed in assessing mathematics teachers' key competencies. *Quaderni di Ricerca in Didattica (Mathematics)*, 2(3), 227–234.
- Glaubitz, M. R. (2011). The use of original sources in the classroom: Empirical research findings. In É. Barbin, M. Kronfellner, & C. Tzanakis (Eds.), *History and epistemology in mathematics education: Proceedings of the 6th European Summer University (ESU 6)* (pp. 351–362). Holzhausen Publishing Ltd..
- Gleason, A. M., & Hughes-Hallett, D. (1992). The calculus consortium based at Harvard University. *Focus on calculus: A newsletter for the calculus consortium at Harvard University*, 1, 1–3. Retrieved from <http://personal.denison.edu/~whiteda/files/Teaching/Pedagogy/Theory%20of%20Pedagogy/Use%20to%20Summarize%20Harvard%20Calc.pdf>, Oct. 2021
- Godelier, M. (1977). *Perspectives in Marxist anthropology*. Cambridge University Press.
- Godino, J. D., Batanero, C., & Font, V. (2007). The onto-semiotic approach to research in mathematics education. *ZDM-Mathematics Education*, 39(1), 127–135. <https://doi.org/10.1007/s11858-006-0004-1>
- Godino, J. D., Batanero, C., & Font, V. (2019). The onto-semiotic approach: Implications for the prescriptive character of didactics. *For the Learning of Mathematics*, 39(1), 37–42. <https://www.jstor.org/stable/26742011>
- Goldbach, C. (1690–1764). <https://www.britannica.com/science/Goldbach-conjecture>
- Gomezescobar, A., Guerrero, S., & Fernandez, R. (2020). How long is it? Difficulties with conventional ruler use in children aged 5 to 8. *Early Childhood Education Journal*, 48, 693–701. <https://doi.org/10.1007/s10643-020-01030-y>
- Gonçalves, C. V. P., & Gomes, A. (2020). Portuguese school teachers' mathematical knowledge for teaching: Questions on numbers and operations. *Quaderni di Ricerca in Didattica (Mathematics)*, 7(special issue), 193–199.
- González, F. (2009). *Problemática del tránsito de la educación secundaria a la educación superior. Un enfoque multidimensional*. Ponencia presentada en VI CIBEM.
- Gonzalez Urbaneja, P. M. (2017). *Los elementos de Euclides. Biblia de la Geometría griega*. Servicio de Publicaciones de la FESPM.
- Grattan-Guinness, I. (2004). History or heritage? An important distinction in mathematics and for mathematics education. *The American Mathematical Monthly*, 111(1), 1–12.
- Gravemeijer, K. P. E. (1994). Developing realistic Mathematics Education. In *Center for Science and Mathematics Education, Freudenthal Institute, Research Group On Mathematic Education*. Utrecht University.
- Gravemeijer, K. P. E. (2004). Creating opportunities for students to reinvent mathematics. In *Regular lecture at the 10th international congress on mathematical education (ICME 10)*.
- Gravemeijer, K. (2007). Emergent modelling as a precursor to mathematical modelling. In W. Blum, P. Galbraith, H. Henn, & M. Niss (Eds.), *Modelling and applications in mathematics education* (pp. 137–144). Springer.
- Gray, J. (2010). *A history of abstract algebra*. Springer.

- Greca Dufranc, I. M., García Terceño, E. M., Fridberg, M., Cronquist, B., & Redfors, A. (2020). Robotics and early-years STEM education: The botSTEM framework and activities. *European Journal of STEM Education*, 5(1), 1. <https://doi.org/10.20897/ejsteme/7948>
- Gronin, J. (2011). *L'herméneutique* (3rd ed.). Presses Universitaires de France.
- Guedj, D. (1999). *The parrot's theorem*. Polis.
- Guevara-Casanova, I., & Burgués-Flamarich, C. (2018). Geometry and visual reasoning. In K. Clark, T. Kjeldsen, S. Schorch, & C. Tzanakis (Eds.), *Mathematics, education and history. ICME-13 monographs* (pp. 165–192). Springer. [https://doi.org/10.1007/978-3-319-73924-3\\_9](https://doi.org/10.1007/978-3-319-73924-3_9)
- Guilford, J. P. (1967). *The nature of human intelligence*. McGraw-Hill.
- Guillemette, D. (2015). Rôle de l'histoire des mathématiques dans l'enseignement-apprentissage des mathématiques : le point de vue socioculturel. In C. Sabena & B. Di Paola (Eds.), *Actes de la 67<sup>e</sup> Réunion de la Commission internationale pour l'étude et l'amélioration de l'enseignement des mathématiques (CIEAEM 67) – Enseigner et apprendre les mathématiques : ressources et obstacles* (pp. 607–618). CIEAEM.
- Guillemette, D. (2017). History of mathematics in secondary school teachers' training: Towards a nonviolent mathematics education. *Educational Studies in Mathematics*, 96(3), 349–365. <https://doi.org/10.1007/s10649-017-9774-3>
- Guillemette, D. (2020). Lecture de textes historiques dans la formation à l'enseignement des mathématiques : choix et modalités de lecture. In B. Di Paola & P. Palhares (Eds.), *Actes de la 71<sup>e</sup> Réunion de la Commission internationale pour l'étude et l'amélioration de l'enseignement des mathématiques (CIEAEM 71) – Connexions et compréhensions dans l'enseignement des mathématiques : donner un sens à un monde complexe* (pp. 443–454). CIEAEM.
- Guillemette, D., & Radford, L. (2022). History of mathematics in the context of mathematics teachers' education: A dialogical/ethical perspective. *ZDM Mathematics Education*, 54, 1493–1505. <https://doi.org/10.1007/s11858-022-01437-4>
- Guillén Soler, G. (2005). Análisis de la clasificación. Una propuesta para abordar la clasificación en el mundo de los sólidos. *Educación Matemática*, 17(2), 117–152.
- Guin, D., & Trouche, L. (1999). The complex process of converting tools into mathematical instruments: The case of calculators. *International Journal of Computers for Mathematical Learning*, 3, 195–227.
- Gustafson, R. (2012). Was Pythagoras Chinese? Revisiting an old debate. *The Mathematics Enthusiast*, 9(1), Article 10. Retrieved May 2022 from <<http://scholarworks.umt.edu/tme/vol9/iss1/10>>
- Gutstein, E. (2003). Teaching and learning mathematics for social justice in an urban, Latino school. *Journal for Research in Mathematics Education*, 34(1), 37–73.
- Gutstein, E. & Peterson, B. (2005). Rethinking mathematics: Teaching social justice by the numbers. Rethinking Schools.
- Hadley, J., & Singmaster, D. (1992). Problems to sharpen the young. *The Mathematical Gazette*, 76(475), 102–126. The Use of the History of Mathematics in the Teaching of Mathematics (Mar., 1992), (25 pages).
- Hammerness, K. (2001). Teachers' visions: The role of personal ideals in school. *Reform Journal of Educational Change*, 2, 143–163.
- Hannula, M. S. (2002). Attitude towards mathematics: Emotions, expectations and values. *Educational Studies in Mathematics*, 49(1), 25–46.
- Hannula, M. S. (2006). Affect in mathematical thinking and learning: Towards integration of emotion, motivation, and cognition. In J. Maasz & W. Schloeglmann (Eds.), *New mathematics education research and practice* (pp. 209–232). Brill Sense.
- Hannula, M. S. (2011). The structure and dynamics of affect in mathematical thinking and learning. In *Cerme 7* (pp. 34–60). University of Rzeszów.
- Hannula, M. S. (2019). Young learners' mathematics-related affect: A commentary on concepts, methods, and developmental trends. *Educational Studies in Mathematics*, 100(3), 309–316. <https://doi.org/10.1007/s10649-018-9865-9>

- Hannula, M., Evans, J., Philippou, G., & Zan, R. (2004). *Affect in mathematics education-exploring theoretical frameworks*. Research Forum. International Group for the Psychology of Mathematics Education.
- Hannula, M. S., Gómez Chacón, I. M., Philippou, G., & Schölglmann, W. (2005). Affect and mathematical thinking. Role of beliefs, emotions and other affective factors. In *Proceedings of the fourth congress of the European Society for Research in Mathematics Education: 18--21 February 2005* (pp. 165–284). European Research in Mathematics Education.
- Harel, I. (1991). *Children designers*. Ablex Publishing Corporation.
- Harper, E. (1987). Ghost or Diophanthus. *Educational Studies of Mathematics*, 18, 75–90.
- Hattie, J., & Timperley, H. (2007). The power of feedback. *Review of Educational Research*, 77(1), 81–112.
- Haydn, T., & Counsell, C. (Eds.). (2003). *History, ICT and learning in the secondary school*. RoutledgeFalmer.
- Healy, L. (2000). Identifying and explaining geometrical relationship: Interactions with robust and soft Cabri constructions. *Proceedings of the 24th PME International Conference* (Vol. 1, pp. 103–117). Hiroshima, Japan.
- Healy, L., & Sutherland, R. (1990). The use of spreadsheets within the mathematics classroom. *International Journal of Mathematics Education in Science and Technology*, 21(6), 847–862.
- Heath, T. L. (Ed.). (1956). *The thirteen books of Euclid's elements*. Dover. ISBN 978-0486600888.
- Heckman, J. J., & Kautz, T. (2012). Hard evidence on soft skills. *Labour Economics*, 19(4), 451–464.
- Hembree, R., & Dessart, D. J. (1986). Effects of hand-held calculators in precollege mathematics education: A meta-analysis. *Journal for Research in Mathematics Education*, 17(2), 83–99.
- Henrique, M. P. (2021). *Metáforas e Toques em Tela: Potencializando Aprendizagens Discentes no Estudo de Retas Paralelas e Transversais*. Doctoral Thesis in Education. Seropédica: UFRRJ/PPGEduCIMAT.
- Henrique, M. P., & Bairral, M. (2019a). *Caderno de Atividades sobre Conceitos Geométricos em Ambientes de Geometria Dinâmica (eBook)* (p. 49) Retrieved from <http://r1.ufrj.br/edur/loja/caderno-de-atividades-sobre-conceitos-geometricos-em-ambientes-de-geometria-dinamica/>
- Henrique, M. P., & Bairral, M. (2019b). Touching, moving and understanding properties related with parallel lines intersected by a transversal line with GeoGebra on smartphones. *Quaderni di Ricerca in Didattica: Matematica*, 3(Special Issue Proceedings CIEAEM70), 109–116.
- Henrique, M. P., & Bairral, M. (submitted). *Retas e ângulos que se movimentam, ideias discentes que somam*.
- Henriques, A. (1999). *Ensino e Aprendizagem da Geometria Métrica: uma sequência didática com auxílio do software Cabri-Geometre*. Thesis. Master in Mathematic Education. Universidade Paulista de São Paulo.
- Hernandez, R. M. (2017). Impact of ICT on education: Challenges and perspectives. *Journal of Educational Psychology-Propositos y Representaciones*, 5(1), 337–347.
- Herodotus (online). Histories. Pekka Mansikka. <https://www.google.com/books/edition/Histories/PnlyEAAAQBAJ?>
- Heyd-Metzuyanim, E., & Sfard, A. (2012). Identity struggles in the mathematics classroom: On learning mathematics as an interplay of mathematizing and identifying. *International Journal of Educational Research*, 51, 128–145.
- Hidalgo Moncada, D., Valencia, S. P., Vanegas, Y. M., & Díez-Palomar, J. (2021). Prácticas de docentes universitarios que fomentan la autorregulación del aprendizaje en las matemáticas. *UNIÓN. Revista Iberoamericana de Educación Matemática*, 17, 62.
- Hiebert, J., & Lefevre, P. (1986). Conceptual and procedural knowledge in mathematics: An introductory analysis. In J. Hiebert (Ed.), *Conceptual and procedural knowledge: The case of mathematics* (pp. 1–27). Lawrence Erlbaum.
- Hill, H., Ball, D. L., & Schilling, S. (2008). Unpacking pedagogical content knowledge: Conceptualizing and measuring teachers' topic-specific knowledge of students. *Journal for Research in Mathematics Education*, 39(4), 372–400. <https://doi.org/10.5951/jresmetheduc.39.4.0372>

- Hintikka, J. (1998). *The principles of mathematics revisited*. Cambridge University Press.
- Hintikka, J. (1999). *Inquiry as inquiry: A logic of scientific discovery*. Springer Science & Business Media.
- Hiriart-Urruty, J. B. (2011). El papel de las conjeturas en el avance de las matemáticas: vueltas y revueltas con ayuda de ejemplos. *Conferencias del Departamento de Estadística e Investigación Operativa. Universidad de Alicante (España)*. Institut de mathématiques. Université Paul Sabatier. Toulouse. <https://dmat.ua.es/es/documentos/actividades/conferencias/conferencia20110511-conjeturas.pdf>
- Hitt, F. (2007). Utilisation de calculatrices symboliques dans le cadre d'une méthode d'apprentissage collaboratif, de débat scientifique et d'auto-réflexion. In M. Baron, D. Guin, & L. Trouche (Eds.), *Environnements informatisés et ressources numériques pour l'apprentissage. Conception et usages, regards croisés* (pp. 65–88). Hermès.
- Hitt, F. (2011). Construction of mathematical knowledge using graphic calculators (CAS) in the mathematics classroom. *International Journal of Mathematics Education and Science and Technology*, 42(6), 723–735.
- Hitt, F., & Kieran, C. (2009). Constructing knowledge via a peer interaction in a CAS environment with tasks designed from a task-technique-theory perspective. *International Journal of Computers for Mathematical Learning*, 14, 121–152.
- Hitt, F., & Quiroz, S. (2019). Formation et évolution des représentations fonctionnelles-spontanées à travers un apprentissage socioculturel. *Annales de didactique et de Sciences Cognitives*, 24, 75–106.
- Hitt, F., & Rivera, S. Q. (2017). La modelisation mathématique et processus de mathématisation dans la formation des enseignants. *Quaderni di Ricerca in Didattica (Mathematics)*, 27(2), 247–252.
- Hitt, F., Cortés, C., & Saboya, M. (2017a). Integrating arithmetic and algebra in a collaborative learning and computational environment using ACODESA. In G. Aldon, F. Hitt, L. Bazzini, & U. Gellert (Eds.), *Mathematics and technology. A C.I.E.A.E.M. Sourcebook* (pp. 285–311). Springer.
- Hitt, F., Saboya, M., & Cortés, C. (2017b). Task design in a paper and pencil and technological environment to promote inclusive learning: An example with polygonal numbers. In G. Aldon, F. Hitt, L. Bazzini, & U. Gellert (Eds.), *Mathematics and technology. A C.I.E.A.E.M. Sourcebook* (pp. 57–74). Springer.
- Hitt, F., Saboya, M., & Cortés, C. (2017c). Rupture or continuity: The arithmetico-algebraic thinking as an alternative in a modelling process in a paper and pencil and technology environment. *Educational Studies in Mathematics*, 94(1), 97–116.
- Hitt, F., Quiroz, S., Saboya, M., & Lupiañez, J-L. (in press). Construction sociale de processus de généralisation arithmético-algébriques dans une approche par compétences à l'école québécoise. *Revue Québécoise de Didactique des Mathématiques*.
- Hofstetter, R. (2012). Educational sciences: Evolutions of a Pluridisciplinary discipline at the crossroads of other disciplinary and professional fields (20th century). *British Journal of Educational Studies*, 60(4), 317–335.
- Hohenwarter, M. (2002a). *GeoGebra – Ein Software system für dynamische Geometrie und Algebra der Ebene*. Master thesis, University of Salzburg.
- Hohenwarter, M. (2002b). *Introduzione a GeoGebra*. Trad. Simona Riva. <https://sodilinux.itd.cnr.it/sdl6x2/documentazione/geogebra/intro-it.pdf>
- Hohenwarter, M., & Jones, K. (2007). Ways of linking geometry and algebra: The case of GeoGebra. *Proceedings of the British Society for Research into Learning Mathematics*, 27(3), 126–131. : BSRLM.
- Hohenwarter, M., & Lavicza, Z. (2011). The strength of the community: How GeoGebra can inspire technology integration in mathematics. In L. Bu & R. Schoen (Eds.), *Model-centered learning. Pathways to mathematical understanding using GeoGebra* (pp. 7–12). Sense Publishers.



- Holm, G., & Zilliacus, H. (2009). Multicultural education and intercultural education: Is there a difference? In M. Talib, J. Loima, H. Paavola, & S. Patrikainen (Eds.), *Dialogues on diversity and global education* (pp. 11–28). Peter Lang. [https://www.researchgate.net/publication/281555019\\_Multicultural\\_education\\_and\\_intercultural\\_education\\_Is\\_there\\_a\\_difference](https://www.researchgate.net/publication/281555019_Multicultural_education_and_intercultural_education_Is_there_a_difference)
- Hong, K. S., & Songan, P. (2011). ICT in the changing landscape of higher education in Southeast Asia. *Australasian Journal of Educational Technology*, 27(8).
- Howells, K. (2018). *The future of education and skills: Education 2030: The future we want*. OECD. [http://www.oecd.org/education/2030/E2030%20Position%20Paper%20\(05.04.2018\).pdf](http://www.oecd.org/education/2030/E2030%20Position%20Paper%20(05.04.2018).pdf)
- Howson, G., Keitel, K., & Kilpatrick, J. (1981). *Curriculum development in mathematics*. Cambridge University Press.
- Hoyles, C., & Noss, R. (1992). A pedagogy for mathematical microworlds. *Educational Studies in Mathematics*, 23, 31–57.
- Hoyles, C., Noss, R., & Kent, P. (2004). On the integration of digital technologies into mathematics classrooms. *International Journal of Computers for Mathematical Learning*, 9, 309–326. <http://www.mdeguzman.net>  
<https://www.encyclopedia.com/history/encyclopedias-almanacs-transcripts-and-maps/dissemination-knowledge>
- Hummes, V. B., Font, V., & Breda, A. (2019). Combined use of the lesson study and the criteria of didactical suitability for the development of the reflection on the own practice in the training of mathematics teachers. *Acta Scientiae*, 21(1), 64–82.
- Hummes, V., Breda, A., Sanchez, A., & Font, V. (2020). Didactical suitability criteria in videos of lesson study. *Quaderni di Ricerca in Didattica (Mathematics)*, 7(special issue), 257–269.
- Ibarra-González, K. P., & Eccius-Wellmann, C. (2018). Desarrollo y Validación de un Instrumento de Medición de la Afectividad respecto a la Comisión de Errores en Matemáticas. *Bolema*, 32, 673–695.
- ICMI. (1976). *Bulletin of the international commission on mathematical instruction*. No. 8, December 1976. Retrived from [https://www.math.uni-bielefeld.de/icmi/bulletin/ICMI\\_08\\_12\\_1976.pdf](https://www.math.uni-bielefeld.de/icmi/bulletin/ICMI_08_12_1976.pdf), Nov, 2020.
- International Mathematical Union. (2021). *Organization – Affiliated Organizations – HPM*. <https://www.mathunion.org/icmi/organization/affiliated-organizations/hpm>. Accessed 4 Jan 2022.
- Iseke-Barnes, J. M. (2000). Ethnomathematics and language in decolonizing mathematics. *Race, Gender & Class*, 7, 133–149.
- ISTE/CSTA (2011). *Computational Thinking Teacher Resource* (2ª edição). Computer Science Teachers Association (CSTA) and the International Society for Technology in Education (ISTE). [https://csta.acm.org/Curriculum/sub/CurrFiles/472.1ICTTeacherResources\\_2ed-SP-vF.pdf](https://csta.acm.org/Curriculum/sub/CurrFiles/472.1ICTTeacherResources_2ed-SP-vF.pdf).
- Ito, M., Gutierrez, K., Livingstone, S., Penuel, B., Rhodes, J., Salen, K., & Watkins, S. C. (2013). Connected learning: An agenda for research and design. *Digital Media and Learning Research Hub*. <https://dmlhub.net/publications/connected-learning-agenda-for-research-and-design/>
- Ivars, P., Fernández, C., & Llinares, S. (2019). A learning trajectory as a scaffold for preservice Teachers' noticing of Students' mathematical understanding. *International Journal of Science and Mathematics Education*, 18, 529–548. <https://doi.org/10.1007/s10763-019-09973-4>
- Izar, S. B. (2016). Museu Virtual: Pantógrafos e Homotetia em aulas de Matemática. *Boletim Gepem*, 69, 162–169. <https://doi.org/10.4322/gepem.2017.013>
- Jablonka, E., & Gellert, U. (2012). Potentials, pitfalls and discriminations: Curriculum conceptions revisited. In O. Skovsmose & B. Geer (Eds.), *Opening the cage: Critique and politics of mathematics education* (pp. 287–307). Sense Publishers.
- Jahnke, H. N. (1983). Technology and education: The example of the computer. *Education Studies in Mathematics*, 14, 87–100.
- Jahnke, H. N. (2014). History in mathematics education: A hermeneutic approach. In M. N. Fried & T. Dreyfus (Eds.), *Mathematics & mathematics education: Searching for common ground* (pp. 75–88). Springer. [https://doi.org/10.1007/978-94-007-7473-5\\_6](https://doi.org/10.1007/978-94-007-7473-5_6)

- Jahnke, H. N., Arcavi, A., Barbin, E., Bekken, O., Furinghetti, F., El Idrissi, A., Silva da Silva, C. M., & Weeks, C. (2002). The use of original sources in the mathematics classroom. In J. Fauvel & J. van Maanen (Eds.), *History in mathematics education: The ICMI study* (pp. 291–328). Kluwer Academic Publishers. [https://doi.org/10.1007/0-306-47220-1\\_9](https://doi.org/10.1007/0-306-47220-1_9)
- Jahnke, H. N., Jankvist, U. T., & Kjeldsen, T. H. (2022). Three past mathematicians' views on history in mathematics teaching and learning: Pointcaré, Klein, and Freudenthal. *ZDM-Mathematics Education*, *54*, 1421–1433. <https://doi.org/10.1007/s11858-022-01376-0>
- Jakobsen, A., Thames, M. H., Ribeiro, C. M., & Delaney, S. (2012). Using practice to define and distinguish horizon content knowledge. In *Pre proceedings of ICME12, the 12th international congress on mathematics education* (pp. 4635–4677). ICMI.
- Janke, H. N., et al. (2000). The use of original sources in mathematics classroom. In J. Fauvel & J. van Maanen (Eds.), *History in mathematics education: The ICMI study* (pp. 291–328). Kluwer.
- Jankvist, U. T. (2007). Empirical research in the field of using history in mathematics education: Review of empirical studies in HPM2004 & ESU4.
- Jankvist, U. T. (2009a). A categorization of the “whys” and “hows” of using history in mathematics education. *Educational Studies in Mathematics*, *71*(3), 235–261. <https://doi.org/10.1007/s10649-008-9174-9>
- Jankvist, U. T. (2009b). *Using history as a “goal” in mathematics education*. Dissertation. Department of Science, Systems and Models, IMFUFA, Roskilde University.
- Jankvist, U. T. (2009c). A characterization of the “whys” and “hows” of using history in mathematics education. *Educational Studies in Mathematics*, *71*(3), 235–261. <https://doi.org/10.1007/s10649-008-9174-9>
- Jankvist, U. T. (2010). An empirical study of using history as a ‘goal’. *Educational Studies in Mathematics*, *74*, 53–74.
- Jankvist, U. T. (2013). History, applications, and philosophy in mathematics education: HAPh-A use of primary sources. *Science and Education*, *22*, 635–656. <https://doi.org/10.1007/s11191-012-9470-8>
- Jankvist, U. T., & Kjeldsen, T. H. (2011). New avenues for history in mathematics education: Mathematical competencies and anchoring. *Science & Education*, *20*(9), 831–862.
- Jankvist, U. T., Clark, K., & Mosvold, R. (2019). Developing mathematical knowledge for teaching teachers: Potentials of history of mathematics in teacher educator training. *Journal of Mathematics Teacher Education*, *23*, 311–332.
- Jantsch, E. (1972). Inter- and transdisciplinary university: A systems approach to education and innovation. *Higher Education*, *1*(1), 7–37.
- Janvier, C. (Ed.). (1987). *Problems of representation in the teaching and learning of mathematics*. Lawrence Erlbaum Associates.
- Jaramillo, D. (2009). *Educación Matemática, Diversidad y Cultura: un ejemplo desde las prácticas sociales y las prácticas escolares en una escuela indígena*. Matemática, Educación y Sociedad-MES. Facultad de Educación. Universidad de Antioquia. Medellín (Colombia). Ponencia Central Mesa Matemática, diversidad y cultura. <https://www.udea.edu.co/wps/portal/udea/web/inicio/investigacion/grupos-investigacion/ciencias-sociales/mes>, [https://scienti.minciencias.gov.co/cv/lac/visualizador/generarCurriculoCv.do?cod\\_rh=0000291013](https://scienti.minciencias.gov.co/cv/lac/visualizador/generarCurriculoCv.do?cod_rh=0000291013), <http://soda.ustadistancia.edu.co/enlinea/congreso/Coloquio/MemoriasColoquio/Documentos/INTERCULTURALIDAD/Ponencia%20Central%20Mesa%20Matematica,%20diversidad%20y%20cultura%20-%20Diana%20Jaramillo.pdf>
- Jaramillo, D. (2011). La educación matemática en una perspectiva sociocultural: tensiones, utopías, futuros posibles. *Revista Educación y Pedagogía*, *23*(59), 13–36.
- Jaworski, B., & Potari, D. (2021). Implementation of a developmental model of teachers' and didacticians' learning through inquiry: Design, operationalization and outcomes. *ZDM-Mathematics Education*, *53*(5), 1073–1084. <https://doi.org/10.1007/s11858-021-01290-x>
- Jenkins, H. (2006). *Convergence culture: Where old and new media collide*. NYU Press.

- Jenkins, H. (2009). *Confronting the challenges of participatory culture. Media education for the 21st century*. MIT Press.
- Jollivet, S. (2009). L'herméneutique de la facticité et la question du « sens d'être » (1921–1923). In S. Jollivet (Ed.), *Heidegger : Sens et histoire (1912–1927)* (pp. 79–114). Presses Universitaires de France.
- Jones, S. M., & Doolittle, E. J. (2017). Social and emotional learning: Introducing the issue. *The Future of Children*, 27, 3–11.
- Joseph, G. (1994). The politics of anti-racist mathematics. *European Education*, 26(1), 67–74.
- Joseph, G. G. (1999). *The crest of the peacock: Non-European roots of mathematics*. Princeton University Press.
- Kahane, J. P. (2002). L'enseignement des sciences mathématiques Commission de réflexion sur l'enseignement des mathématiques. Ed. Odile Jacob Rapport au Ministre de l'Éducation Nationale.
- Karp, A. (2016). Reflecting on the current issues in mathematics education. In *Current issues in mathematics education* (pp. 1–12). Materials of the American-Russian Workshop. [https://www.comap.com/Free/C\\_I\\_IN\\_MAT\\_ED/PDF/CURRENT\\_ISSUES\\_IN\\_MAT\\_EDUCATION.pdf](https://www.comap.com/Free/C_I_IN_MAT_ED/PDF/CURRENT_ISSUES_IN_MAT_EDUCATION.pdf)
- Karp, A., & Schubring, G. (Eds.). (2014). *Handbook on the history of mathematics education*. Springer.
- Kasimatis, K., Moutsios-Rentzos, A., & Kalavasis, F. (2021). A systemic approach to authentic evaluation in education. In T. Barkatsas & P. McLaughlin (Eds.), *Authentic assessment and evaluation approaches and practices in a digital era* (pp. 329–349). Leiden, Netherlands. isbn:978-90-04-50155-3.
- Kasner, E., & Newman, J. R. (1988). Pastimes of past and present times. In J. R. Newman (Ed.), *The world of mathematics – a small library of the literature of mathematics from A'h-mosé the scribe to Albert Einstein* (pp. 2393–2414). Tempus Books.
- Katsap A., & Silverman F. L. (2016). Transformations, shapes and patterns analysis in the Negev Bedouins' embroideries. In *Ethnomathematics of Negev Bedouins' existence in forms, symbols and geometric patterns*. SensePublishers. [https://doi.org/10.1007/978-94-6209-950-0\\_6](https://doi.org/10.1007/978-94-6209-950-0_6).
- Katz, V. J. (1997). Algebra and its teaching: An historical survey. *Journal of Mathematical Behavior*, 16(1), 25–38.
- Katz, V. (Ed.). (2000). *Using history to teach mathematics: An international perspective* (MAA notes) (Vol. 51). The Mathematical Association of America.
- Katz, V. (2004). *The history of mathematics*. (Brief Edition). Person Education Inc.
- Katz, V. J. (2009). *History of mathematics*. Pearson.
- Katz, V., & Tzanakis, C. (Eds.). (2011). *Recent developments on introducing a historical dimension in mathematics education*. The Mathematical Association of America.
- Keitel, C. (2004). *La enseñanza de las matemáticas en la sociedad del conocimiento o ¿Cuánta matemática necesita un Primer Ministro? Las Matemáticas en la Era del conocimiento*. Actas del XI CEAM. Ed. Sociedad Andaluza de Educación Matemática Thales. Huelva. ISBN:84–933040. Huelva (España).
- Keitel, C. (2006). *Perceptions of mathematics and mathematics education in the course of history – A review of western perspectives*. [https://link.springer.com/chapter/10.1007/0-387-29723-5\\_5](https://link.springer.com/chapter/10.1007/0-387-29723-5_5)
- Keitel, C., Kotzmann, E., & Skovsmose, O. (1993). Beyond the tunnel vision: Analysing the relationship between mathematics education, society and technology. In C. Keitel & K. Ruthven (Eds.), *Learning from computers: Mathematics education and technology* (pp. 242–279). Springer.
- Kelley T. R., & Knowles J. G. (2016). A conceptual framework for integrated STEM education. *International Journal of STEM Education*, 3, 1-11. Open Access: <https://doi.org/10.1186/s40594-016-0046-z>.
- Khan, S., LaFrance, S., & Tran, H.T.T. (2022). After plantations' precarities: Curating math-thematic curriculum plots in initial teacher education for multispecies' flourishing and a freedom-yet-to-come. *Research in Mathematics Education*, Khan, La France, Tran (2022). After plantations' precarities etc. *Research in Mathematics Education*. <https://doi.org/10.1080/14794802.2022.2090421>

- Khoo, S.-M., Haapakoski, J., Hellstén, M., & Malone, J. (2018). Moving from interdisciplinary research to transdisciplinary educational ethics: Bridging epistemological differences in researching higher education internationalization(s). *European Educational Research Journal*, 18(2), 181–199.
- Kilpatrick, J. (2012). The new math as an international phenomenon. *ZDM Mathematics Education*, 44, 563–571. <https://doi.org/10.1007/s11858-012-0393-2>
- King, J., & Schattschneider, D. (1997). *Geometry turned on: Dynamic software in learning, teaching, and research* (n. 41). Cambridge University Press.
- Kirshner, D. (2002). Untangling teachers' diverse aspirations for student learning: A crossdisciplinary strategy for relating psychological theory to pedagogical practice. *Journal for Research in Mathematics Education*, 33(1), 46–58.
- Kjeldsen, T. H. (2011). Uses of history in mathematics education: Development of learning strategies and historical awareness. In M. Pytlet, T. Rowland, & E. Swoboda (Eds.), *Proc. of CERME 7*. University of Rzeszow.
- Kjeldsen, T., & Blomhøj, M. (2012). Beyond motivation: History as a method for learning meta-discursive rules in mathematics. *Educational Studies in Mathematics*, 80(3), 327–349. <https://doi.org/10.1007/s10649-011-9352-z>
- Klein, R., & Showalter, D. (2012). Where's the math? In J. Díez-Palomar & C. Kanés (Eds.), *Family and community in and out of the classroom: Ways to improve mathematics achievement* (pp. 115–122). Univ. Autònoma de Barcelona.
- Kline, M. (1964). *Mathematics in western culture*. Oxford University Press.
- Kline, M. (1973). *Why Johnny Can't add: The failure of the new math*. St. Martin's Press.
- Knijnik, G. (1996). *Exclusao e resistência – Educacao Matemática e Legitimacao Cultural*. Artes Médicas.
- Knijnik, G. (1998). Educação Matemática e os problemas da 'vida real. En: À. Chassot y R. J. d. Oliveira (Eds.), *Ciência, ética e cultura na educação, São Leopoldo*, UNISINOS.
- Knijnik, G. (2004). Etnomatemática e educação no movimento 'Sem Terra'. En: G. Knijnik, F. Wanderer y C. Oliverira (Eds.), *Etnomatemática: currículo e formação de professores* (pp. 53–69). EDUNISC.
- Knijnik, G. (2005). Cultural differences, oral mathematics and calculators in a teacher training course of the Brazilian landless movement. *ZDM Zentralblatt für Didaktik der Mathematik*, 37(2), 101–108.
- Knijnik, G. (2007). Mathematics education and the Brazilian landless movement: Three different mathematics in the context of the struggle for social justice. *Philosophy of Mathematics Education Journal*, 21(1), 1–18.
- Knijnik, G., Wanderer, F., & Oliveira, C. J. (2005). Cultural differences, oral mathematics and calculators in a teacher training course of the Brazilian landless movement. *ZDM Zentralblatt für Didaktik der Mathematik*, 37(2), 101–108.
- Knobel, M., & Lankshear, C. (2005). *Memes and affinities: Cultural replication and literacy education*. Miami National Reading Conference. [https://www.academia.edu/3011351/Memes\\_and\\_affinities\\_Cultural\\_replication\\_and\\_literacy\\_education](https://www.academia.edu/3011351/Memes_and_affinities_Cultural_replication_and_literacy_education)
- Koehler, M. J., & Mishra, P. (2009). What is technological pedagogical content knowledge? *Contemporary Issues in Technology and Teacher Education*, 9(1), 60–70.
- Koley, S. (2022). Geometrical contribution of ŚRĪDHARĀCĀRYA. *Science and Culture*, 88(3–4), 101–107. <https://doi.org/10.36094/sc.v88.2022>
- Kommers, P. (2000). Information and communication technology (ICT) for education: Research and development for the educational integration of technology in Eastern European countries. *Educational Technology Research and Development*, 48, 103–111.
- Kotarinou, P., & Stathopoulou, C. (2015). Using drama techniques for facilitating democratic access to mathematical ideas for all learners. In U. Gellert, J. Gimenez, C. Hahn, & S. Kafoussi (Eds.), *Educational paths to mathematics* (pp. 323–340). Springer.

- Kotsopoulos, D., Makosz, S., Zambrzycka, J., & McCarthy, K. (2015). The effects of different pedagogical approaches on the learning of length measurement in kindergarten. *Early Childhood Education Journal*, 43, 531–539. <https://doi.org/10.1007/s10643-014-0686-x>
- Kozma, R. B. (2002). *ICT and educational reform in developed and developing countries*. Center for Technology in Learning\SRI International.
- Krainer, K., Chapman, O., & Zaslavsky, O. (2014). Mathematics teacher educator as learner. In S. Lerman (Ed.), *Encyclopedia of mathematics education* (pp. 431–434). Springer.
- Kumashiro, K. K. (2009). *Against common sense: Preparing anti-oppressive teachers in six disciplines*. Routledge.
- Kutzler, B. (2000). *The algebraic calculator as a pedagogical tool for teaching mathematics*. Paper presented at the T3 world-wide conference, Tokyo, Japan.
- Laborde, C. (2001). Integration of technology in the design of geometry tasks with Cabri geometry. *International Journal of Computers for Mathematical Learning*, 6(3), 283–217.
- Laborde, J. M. (2016). SOME CaBrI historical background. In M. Bates & A. Usiskin (Eds.), *Digital curricula in school mathematics* (pp. 53–74). Information Age Publishing.
- Laia, M. M. D., Cunha, M. A. V. C. D., Nogueira, A. R. R., & Mazzon, J. A. (2011). Electronic government policies in Brazil: Context, ICT management and outcomes. *Revista de Administração de Empresas*, 51(1), 43–57.
- Lample, G., & Charton, F. (2019). Deep learning for symbolic mathematics. *arXiv preprint arXiv:1912.01412*.
- Lancy, D. (1983). *Cross-cultural studies in cognition and mathematics*. Academic.
- Latour, A. (2010). *L'éducation interculturelle: qu'en pensent les enseignants oeuvrant en milieu homogène?* Université du Québec à Trois-Rivières.
- Leder, G. C. (1987). Attitudes towards mathematics. In T. A. Romberg & D. M. Steward (Eds.), *The monitoring of school mathematics* (Vol. 2, pp. 261–277). Wisconsin Center for Education Research.
- Leder, G. (1992). Mathematics and gender: Changing perspectives. In D. A. Grouws (Ed.), *Handbook of research in mathematics teaching and learning* (pp. 597–622). Macmillan.
- Legrand, M. (2001). Scientific debate in mathematics courses. In D. Holton (Ed.), *The teaching and learning of mathematics at university level: An ICMI Study* (pp. 127–135). Kluwer Academic Publishers.
- Lehrer, R. (2003). Developing understanding of measurement. In J. Kilpatrick, W. G. Martin, & D. Schifter (Eds.), *A research companion to principles and standards for school mathematics* (pp. 179–192). National Council of Teachers of Mathematics.
- Leibniz, G. W. (1710). Brevis description Machinae Arithmeticae, cum figura, dans *Miscellanea Berolinensia ad incrementum scientiarum*, 317–319.
- Leikin, R., & Sriraman, B. (2017). *Creativity and giftedness. Interdisciplinary perspectives from mathematics and beyond*. Springer International Publishing.
- Le-Maur, C. (1778). Elementos de matemática pura. Tomo primero. Aritmética universal. .
- Leonard, J. (2008). *Culturally responsive pedagogy in the mathematics classroom: Strategies for teachers and students*. Routledge.
- León-Mantero, C., Santiago, A., & Gutiérrez-Arenas, M. P. (2020). El método de máximos y mínimos en los libros de texto españoles del siglo XVIII: influencias europeas. In C. López-Esteban & A. Maz-Machado (Eds.), *Las matemáticas en España durante el siglo XVIII a través de los libros y sus autores* (pp. 115–133). Universidad de Salamanca.
- León-Mantero, C., Madrid, M. J., & Maz-Machado, A. (2022). La evolución de los métodos de resolución de triángulos oblicuángulos en los libros de texto sobre trigonometría publicados en España. In J. A. Fernández-Plaza, J. L. Lupiáñez, A. Moreno, & R. Ramírez (Eds.), *Investigación en Educación Matemática. Homenaje a los profesores Pablo Flores e Isidoro Segovia* (pp. 213–230). Octaedro.
- Leontyev, A. (1978). *Activity, consciousness, and personality*. Prentice Hall.
- Lesmos de Castro, L., Ortega, M. A., Flecha, R., Giménez, F., & Valls, R. (1982). *Las matemáticas en las escuelas de adultos*. El Roure.

- Leung, A., Baccaglioni-Franck, A., & Mariotti, M. (2013). Discernment of invariants in dynamic geometry environments. *Educational Studies in Mathematics*, 84(3), 430–460.
- Li, Y., Wang, K., Xiao, F., & Froyd, J. E. (2020). Research and trends in STEAM education: A systematic review of journal publications. *International Journal of STEM Education*, 7, 11.
- Ligozat, F., & Schubauer-Leoni, M.-L. (2009). The joint action theory in didactics. Why do we need it in the case of teaching and learning mathematics. In V. Durand-Guerrier, S. Soury-Lavergne, & F. Arzarello (Eds.), *Proceedings of CERME6, January 28th–February 1st 2009* (pp. 1615–1624). INRP. [www.inrp.fr/editions/cerme6](http://www.inrp.fr/editions/cerme6)
- Lim, S. Y., & Chapman, E. (2015). Effects of using history as a tool to teach mathematics on students' attitudes, anxiety, motivation and achievement in grade 11 classrooms. *Educational Studies in Mathematics*, 90(2), 189–212.
- Lipka, J., Sharp, N., Adams, B., & Sharp, F. (2007). Creating a third space for authentic biculturalism: Examples from math in a cultural context. *Journal of American Indian Education*, 46(3), 94–115.
- Liu, P.-H. (2003). Connecting Research to Teaching: Do teachers need to incorporate the history of mathematics in their teaching. *The Mathematics Teacher*, 96(6), 416–421. <https://doi.org/10.5951/MT.96.6.0416>
- Llinares, S., Fernández, C., & Sánchez-Matamoros, G. (2016). Changes in how prospective teachers anticipate secondary students' answers. *EURASIA Journal of Mathematics, Science and Technology Education*, 12(8), 2155–2170. <https://doi.org/10.12973/eurasia.2016.1295a>
- Llinares, S., Ivars, P., Buforn, À., & Groenwald, C. (2019). “Mirar profesionalmente” las situaciones de enseñanza: una competencia basada en el conocimiento. In E. Badillo, N. Climent, C. Fernández, & M. T. González (Eds.), *Investigación sobre el profesor de matemáticas: formación, práctica de aula, conocimiento y competencia profesional* (pp. 177–192). Ediciones Universidad Salamanca.
- Lobo da Costa, N. M. (1997). *Funções Seno e Cosseno: Uma Sequência de Ensino a partir dos Contextos do 'Mundo Experimental' e do Computador*. Thesis, Master in Mathematic Education. Pontifícia Universidade Católica de São Paulo – PUCSP.
- Lobo da Costa, N. M., & Prado, M. E. B. (2015). A integração das tecnologias digitais ao ensino de Matemática: desafio constante no cotidiano escolar do professor. *Perspectivas da Educação Matemática*, 8(16), 99–119.
- Lobo da Costa, N., Brito Prado, M. E. B., & Lopes Galvao, M. E. E. (2015). Mathematics teaching and digital technologies: A challenge to the teacher's everyday school life. *Quaderni di Ricerca in Didattica (Mathematics)*, 25(2), 263–270.
- Lobo da Costa, N., Brito Prado, M. E. B., & Alves Dias, M. (2017). Investigative tasks: Possibilities to develop teachers' technological pedagogical content knowledge. *Quaderni di Ricerca in Didattica (Mathematics)*, 27(2), 235–240.
- Lope y Aguilar, T. (1794). *Curso de matemáticas: para la enseñanza de los caballeros seminaristas del Real Seminario de Nobles de Madrid. Tomo I*. Imprenta Real.
- Lopes, P. C., & Fernandes, E. (2014). Literacy, reasoning and statistical thinking with robots. *Quadrante*, 23(2), 69–93.
- Lopes Galvao, M. E. E., Garcia Silva, A. F., & Pietropaolo, R. C. (2015). Collaborative study groups in teacher development: A university school project. *Quaderni di Ricerca in Didattica (Mathematics)*, 25(2), 251–254.
- Lopes Galvao, M. E. E., Lobo da Costa, N., & Brito Prado, B. (2017). Problem-based learning: An investigative approach to teach optimization problems. *Quaderni di Ricerca in Didattica (Mathematics)*, 27(2), 241–246.
- López, L. M. (2021). Noticing: Una revisión bibliográfica sobre los orígenes y perspectivas actuales. *RECHIEM. Revista Chilena de Educación Matemática*, 13(3), 79–92. <https://doi.org/10.46219/rechiem.v13i3.92>
- López, L., & Küper, W. (1999). La educación intercultural bilingüe en América Latina: balance y perspectivas. *Revista Iberoamericana de Educación*, 20, 85.

- Lorde, A. (1979). The Master's tools will never dismantle the Master's house. In C. Moraga & G. Anzaldúa (Eds.), *This bridge called my back: Writings by radical women of color* (pp. 25–28). Kitchen Table Press.
- Lorenzo, J. (2016). Renovación pedagógica en Aragón: estudio de caso del movimiento de renovación pedagógica “aula libre” entre 1975 y 2012. *Tendencias Pedagógicas*, 27, 201–230.
- Luengo, H. (2018). *Cambios en la Educación*. Diario de avisos. El Español. <https://diariodeavisos.lespanol.com/2018/03/cambios-la-educacion/>
- Lupiáñez, J. L. (2018). Resolución de problemas y tecnología en el desarrollo de la competencia STEM. In P. Flores, J. L. Lupiáñez, & I. Segovia (Eds.), *Enseñar matemáticas. Un homenaje a los profesores Francisco Fernández y Francisco Ruiz* (pp. 203–214). Atrio.
- Luz, Y., & Yerushalmy, M. (2019). Students' conceptions through the lens of a dynamic online geometry assessment platform. *The Journal of Mathematical Behavior*, 54, 100682.
- Maass, K., Cobb, P., Krainer, K., et al. (2019a). Different ways to implement innovative teaching approaches at scale. *Educational Studies in Mathematics*, 102, 303–318. <https://doi.org/10.1007/s10649-019-09920-8>
- Maass, K., Geiger, V., Romero-Ariza, M., & Goos, M. (2019b). The role of mathematics in interdisciplinary STEM education. *ZDM Mathematics Education*, 51(6), 869–884. <https://doi.org/10.1007/s11858-019-01100-5>
- Madrid, M. J., Maz-Machado, A., León-Mantero, C., & López-Esteban, C. (2017). Applications of mathematics to everyday life in Spanish arithmetic books published in the 16th century, Aplicaciones de Las Matemáticas a la Vida Diaria en Los Libros de Aritmética Españoles del Siglo XVI. *Bolema - Mathematics Education Bulletin*. <https://doi.org/10.1590/1980-4415v31n59a12>
- Madrid, M. J., León-Mantero, C., Maz-Machado, A., & López-Esteban, C. (2019a). El desarrollo del concepto de ecuación en libros españoles de matemáticas del siglo XVIII. In J. M. Marbán, M. Arce, A. Maroto, J. M. Muñoz-Escolano, & Á. Alsina (Eds.), *Investigación en Educación Matemática XXIII* (pp. 403–412). Universidad de Valladolid.
- Madrid, M. J., Maz-Machado, A., López, C., & León-Mantero, C. (2019b). Old arithmetic books: Mathematics in Spain in the first half of the sixteenth century. *International Electronic Journal of Mathematics Education*, 15(1), em0553. <https://doi.org/10.29333/iejme/5935>
- Madrid, M. J., León-Mantero, C., & López-Esteban, C. (2020). El tratamiento del álgebra en los libros de matemáticas en castellano en el siglo XVIII. In C. López-Esteban & A. Maz-Machado (Eds.), *Las matemáticas en España durante el siglo XVIII a través de los libros y sus autores* (pp. 199–221). Universidad de Salamanca.
- Madrid, M. J., Maz-Machado, A., Almaraz-Menéndez, F., & León-Mantero, C. (2021). Comparison between a modern-day multiplication method and two historical ones by trainee teachers. *Mathematics*, 9(4), 349. <https://doi.org/10.3390/math9040349>
- Magnaghi-Delfino, P., & Norando, T. (2019). How to solve second degree algebraic equations using geometry. In P. Magnaghi-Delfino, G. Mele, & T. Norando (Eds.), *Faces of geometry. From Agnesi to Mirzakhani* (Lecture Notes in Networks and Systems) (Vol. 88). Springer. [https://doi.org/10.1007/978-3-030-29796-1\\_11](https://doi.org/10.1007/978-3-030-29796-1_11)
- Major, A. (2017). Numbers with personality. In D. Swart, C. Séquin, & K. Fenyvesi (Eds.), *Proceedings of bridges 2017: Mathematics, art, music, architecture, education, culture*. Retrieved May 2022 from <<https://archive.bridgesmathart.org/2017/bridges2017-1.html>>
- Mapolelo, D. C., & Akinsola, M. K. (2015). Preparation of mathematics teachers: lessons from review of literature on teachers' knowledge, beliefs, and teacher education. *International Journal of Educational Studies*, 2(01), 1–12.
- Mariotti, M. A. (2006). Proof and proving in mathematics education. In A. Gutiérrez & P. Boero (Eds.), *Handbook of research on the psychology of mathematics education* (pp. 173–204). Brill Sense.
- Martin, Y. (2010). Une géométrie dynamique enrichie. *Express*, 35, 165–272.
- Martínez, O. (2014). El afecto en el aprendizaje de la Matemática: una mirada desde los docentes paraguayos. In *Actas de la RELME 25* (pp. 1954–1961). CLAME.

- Martínez, M., & Arévalo, E. (2017). Análisis didáctico de prácticas matemáticas de aula utilizando “the knowledge quartet”. *El pensamiento del profesor, sus prácticas y elementos para su formación profesional. Acta Latinoamericana de Matemática Educativa* (pp. 1095–1104). CLAME.
- Martínez Padrón, O. (2009). Sistemas de creencias hacia la matemática observados en docentes, en servicio, que se forman en educación integral. In *Ponencia presentada en el VI CIBEM*.
- Martínez Padrón, O., Villegas, M., & González, F. (2007). Afecto y comprensión en la resolución de problemas. In *Ponencia presentada en RELME 21*. Universidad del Zulia.
- Martín-Páez, T., Aguilera, D., Perales-Palacios, F. J., & Vílchez-González, J. M. (2019). What are we talking about when we talk about STEM education? A review of literature. *Science Education*, 103, 799–822. <https://doi.org/10.1002/sce.21522>
- Martins, A. P., Clain, T., Ribeiro, A., Costa, C., Pinto, H., Gomes, H., & Menezes, L. (2021). Conceções e práticas de professores sobre a História no ensino da Matemática a num contexto de formação. *Millenium*, 2(8), 249–259.
- Marton, F., Tsui, A. B. M., Chik, P. P. M., Ko, P. Y., & Lo, M. L. (Eds.). (2004). *Classroom discourse and the space of learning*. Lawrence Erlbaum Associates.
- Mason, J. (1996). Expressing generality and roots of algebra. In N. Bernarx, C. Kieran, & L. Lee (Eds.), *Approaches to algebra: Perspectives for research and teaching* (pp. 65–86). Kluwer Academic Publishers.
- Massa, R. (2014). Historical activities in the mathematics classroom: Tartaglia’s Nova Scientia (1537). *Teaching Innovations*, 27(3), 114–126.
- Matos, M., Almeida, M. C., & Candeias, R. (2021). Models of teacher education and professional knowledge. *Educação & Realidade*, 46, 3. <https://doi.org/10.1590/2175-6236112154>
- Matthews, J. (1989). *Escalante: The best teacher in America*. Henry Holt.
- Maturana, H. (1978). Biology of language: The epistemology of reality. In G. A. Miller & E. Lenneberg (Eds.), *Psychology and biology of language and thought* (pp. 27–64). NY Academic Press.
- Maz, A. (2009). Investigación histórica de conceptos en los libros de matemáticas. In M. J. González, M. T. González, & J. Murillo (Eds.), *Investigación en Educación Matemática XIII* (pp. 5–20). Sociedad Española de Investigación en Educación Matemática, SEIEM.
- Maz, A., & Rico, L. (2015). Principios didácticos en textos españoles de matemáticas en los siglos XVIII y XIX. *Revista Latinoamericana de Investigación En Matemática Educativa*, 18(1), 49–76. <https://doi.org/10.12802/relime.13.1812>
- Mazzocchi, F. (2022). Diving deeper into the concept of “cultural heritage” and its relationship with epistemic diversity. *Social Epistemology*, 36(3), 393–406. <https://doi.org/10.1080/02691728.2021.2023682>
- McDonald, J. K., Yanchar, S. C., & Osguthorpe, R. T. (2005). Learning from programmed instruction: Examining implications for modern instructional technology. *Educational Technology Research and Development*, 53, 84–98. <https://doi.org/10.1007/BF02504867>
- McLeod, D. B. (1989). Beliefs, attitudes, and emotions: New views of affect in mathematics education. In D. B. McLeod & V. M. Adams (Eds.), *Affect and mathematical problem solving* (pp. 245–258). Springer.
- McLeod, D. B. (1992). Research on affect in mathematics education: A reconceptualization. In D. A. Grouws (Ed.), *Handbook of research on mathematics teaching and learning* (pp. 575–596). NCTM.
- McLeod, D. B. (1994). Research on affect and mathematics learning in the JRME: 1970 to the present. *Mathematics Education Research Journal*, 25(6), 637–647. <https://doi.org/10.5951/jresmetheduc.25.6.0637>
- McTierna, J. (1995). *Die hard with a vengeance* (1995). American action thriller film. [https://en.wikipedia.org/wiki/Die\\_Hard\\_with\\_a\\_Vengeance](https://en.wikipedia.org/wiki/Die_Hard_with_a_Vengeance)
- Meaney, T., Trinick, T., & Allen, P. (2021). Ethnomathematics in education: The need for cultural symmetry. In M. Danesi (Ed.), *Handbook of cognitive mathematics*. Springer. [https://doi.org/10.1007/978-3-030-44982-7\\_4-1](https://doi.org/10.1007/978-3-030-44982-7_4-1)



- Meavilla, V., & Oller, A. M. (2014). El simbolismo algebraico en tres álgebras españolas del siglo XVI. *Números*, 87, 59–68.
- MECyD. (2006). *Enfoques actuales en la Didáctica de las matemáticas*. Instituto Superior de Educación. Ministerio de Educación, Cultura y Deporte. Área de Educación. <https://sede.educacion.gob.es/publiventa/enfoques-actuales-en-la-didactica-de-las-matematicas/ciencia/12128>
- Meer, N., Modood, T., & Zappata-Barrero, R. (2016). *Interculturalism and Multiculturalism, Edinburgh*. University Press.
- Mehler, J., & Bever, T. G. (1967). Cognitive capacity of very young children. *Science*, 158(3797), 141–142.
- Menezes, L., Oliveira, H., & Canavarró, A. P. (2015). Inquiry-based mathematics teaching: The case of Célia. In U. Gellert, J. Gimenez Rodriguez, C. Hahn, & S. Kafoussi (Eds.), *Educational paths to mathematics* (pp. 305–321). Springer.
- Menna, S., & Salvatico, L. (2000). *Rationality and methodology in bacon's Novum Organum* (Cuadernos no 15) (pp. 139–144). Facultad Humanidades y Ciencias Sociales. Universidad de Jujuy.
- Menninger, K. (1992). *Number words and number symbols*. Dover Publications.
- Menon, U. (2013). Mathematisation-vertical and horizontal. epISTEME 5 international conference to review research on science, technology and mathematics education, conference proceedings. Mumbai, India. <http://episteme5.hbcse.tifr.res.in/index.php/episteme5/5/paper/view/168/52>
- Merfat, A. (2015). Examples of current issues in the multicultural classroom. *Journal of Education and Practice*. IISTE, 6(10), 87–88.
- Mersenni, F. M. (1644). *Cogitata physico-matematica: In quibus tam naturae quàm artis effectus admirandi certissimis demonstrationibus explicantur*. Sumptibus Antonij Bertier, viâ Iacobæâ.
- Mersin, N., & Durmus, S. (2021). Effects of the enriched history of mathematics course on prospective mathematics teachers. *International Journal of Curriculum and Instruction*, 13-(1) Special Issue, 635–669.
- Meza, L. G. (2009). Elementos de pensamiento crítico en Paulo Freire: Implicaciones para la educación superior. *Revista Digital Matemática, Educación e Internet*, 10(1), 1–10. Costa Rica.
- Migliorini, A. (2022, 8 Febbraio). Il problema della Dad è la didattica non la tecnologia. In *Domani*. <https://www.editorialedomani.it/idee/commenti/dad-didattica-distanza-tecnologia-scuola-lazioni-fdnukrvk>.
- Millán, A. (1991). Los estudios de Geometría Superior en España en el siglo XIX. *Llull, Revista de La Sociedad Española de Historia de Las Ciencias*, 14, 117–186.
- Millán Gasca, A., & Cleme, E. G. (2021). *Integrating history of mathematics with foundational contents in the education of prospective elementary teachers*. <http://dml.mathdoc.fr/item/hal-01349254/>
- Milner, R. M. (2016). *The world made meme: Public conversations and participatory media*. MIT Press.
- Mishra, P., & Koehler, M. (2006). Technological pedagogical content knowledge: A framework for teacher knowledge. *Teachers College Record*, 108(6), 1017–1054.
- Miskulin, R. G. S. (1993). A importância da Heurística no processo de construção de Noções Geométricas em Ambientes Informatizados. In J. A. Valente (org.). *Computadores e conhecimento: repensando a educação* (pp. 208–233). UNICAMP/NIED.
- Molnar, A. (1997). Computers in education: A brief history. *The journal*, 24(11), 63–68.
- Montaigne, M. (1580/1997). *Les essais, Bibliothèque de la pléiade*. Gallimard.
- Montecino, A., & Valero, P. (2017). Mathematics teachers as products and agents: To be and not to be. That's the point! In H. Straehler-Pohl, N. Bohlmann, & A. Pais (Eds.), *The disorder of mathematics education*. Springer. [https://doi.org/10.1007/978-3-319-34006-7\\_9](https://doi.org/10.1007/978-3-319-34006-7_9)
- Monteiro, A. (2005). Currículo de Matemáticas: reflexões numa perspectiva enomatemática, 7. *Encuentro de Educación Matemática*, Asocolme, Tunja.

- Montes, M. A., Contreras, L. C., & Carrillo, J. (2013a). Conocimiento del profesor de matemáticas: Enfoques del MKT y del MTSK. In A. Berciano, G. Gutiérrez, A. Estepa, & N. Climent (Eds.), *Investigación en Educación Matemática XVII* (pp. 403–410). SEIEM.
- Montes, M. A., Aguilar, A., Carrillo, J., & Muñoz-Catalán, M. C. (2013b). MTSK: From common and horizon knowledge to knowledge of topics and structures. In *Proceedings of eighth ERME congress*.
- Moreira, D. (2003). A Matemática na educação familiar: Memórias escolares, ideias sobre a Matemática e relação educativa em grupos domésticos de baixa escolaridade. *Quadrante. Revista de Investigação em Educação Matemática*, XII(2), 3–23.
- Moreira, D., & Pires, G. (2012). O Processo Educativo das Crianças Ciganas e a Aprendizagem da Matemática. Em Ana Isabel Afonso (Org) *Etnografias com Ciganos*. In *Diferenciação e Resistência Cultural* (pp. 71–87). Edições Colibri.
- Moreno, M., Sánchez-Matamoros, G., Callejo, M. L., Pérez-Tyteca, P., & Llinares, S. (2021). How prospective kindergarten teachers develop their noticing skills: The instrumentation of a learning trajectory. *ZDM-Mathematics Education*, 53, 57–72. <https://doi.org/10.1007/s11858-021-01234-5>
- Moses, R., & Cobb, C. (2001). *Radical equations: Civil rights from Mississippi to the algebra project*. Beacon Press.
- Mosvold, R., Jakobsen, A., & Jankvist, U. T. (2014). What a mathematical knowledge for teaching may profit from the study of history of mathematics. *Science & Education*, 23, 47–60.
- Moutsios-Rentzos, A., & Kalavasis, F. (2016). Systemic approaches to the complexity in mathematics education research. *International Journal for Mathematics in Education (HMS-i-jme)*, 7, 97–119.
- Moutsios-Rentzos, A., & Spyrou, P. (2015). Fostering internal need for proof: a reading of the genesis of proof in ancient Greece. *Philosophy of Mathematics Education Journal*, 29. Retrieved from <http://socialsciences.exeter.ac.uk/education/research/centres/stem/publications/pmej/pome29/index.html>
- Moutsios-Rentzos, A., Spyrou, P., & Peteinara, A. (2014). The objectification of the right-angled triangle in the teaching of the Pythagorean theorem: An empirical investigation. *Educational Studies in Mathematics*, 85(1), 29–51.
- Moutsios-Rentzos, A., Kalavasis, F., & Meimaris, M. (2019). “My relationship with mathematics”: Multimodal realisations and realities. In A. Moutsios-Rentzos, M. Meimaris, & A. Giannakouloupolous (Eds.), *Proceedings of the international digital storytelling conference “current trends in digital storytelling: Research & Practices”* (pp. 186–194). UNESCO Club of Zakynthos.
- Moutsios-Rentzos, A., Pinnika, V., Kritikos, G., & Kalavasis, F. (2020). Appearances of the equals sign in primary school mathematics and natural sciences: An interdisciplinary, systemic approach. *Quaderni di Ricerca in Didattica*, 7, 285–294.
- Moutsios-Rentzos, A., Kalavasis, F., Meimaris, M., & Kritikos, G. (2022). “My relationship with mathematics”: a digital storytelling-centered investigation with pre-service teachers. Manuscript submitted for publication.
- Moyon, M. (2017). Teaching mathematics and algorithmics with recreational problems: The Liber Abaci of Fibonacci. In É. Barbin, U. T. Jankvist, T. H. Kjeldsen, B. Smestad, & C. Tzanakis (Eds.), *Proceedings of the Eighth European Summer University on History and Epistemology in Mathematics Education (ESU-8)* (Skriftserie 2019, nr 11) (pp. 417–436). Oslo Metropolitan University.
- Mulat, T., & Berman, A. (2015). A pedagogical coaching design focused on the pedagogy of questioning in teaching mathematics. *Quaderni di Ricerca in Didattica (Mathematics)*, 25(2), 333–336.
- Muldner, K., & Burleson, W. (2014). Utilizing sensor data to model students’ creativity in a digital environment. *Computers in Human Behavior*, 42(C), 127–137.
- Munter, C. (2014). Developing visions of high-quality mathematics instruction. *Journal for Research in Mathematics Education*, 45, 584–635.

- Naresh, N. (2015). The role of a critical ethnomathematics curriculum in transforming and empowering learners. *Revista Latinoamericana de Etnomatemática*, 8(2), 450–471.
- Nataraj, M. S., & Thomas, M. (2017). Teaching and learning middle school algebra: Valuable lessons from the history of mathematics. In S. Stewart (Ed.), *And the rest is just algebra*. Springer. [https://doi.org/10.1007/978-3-319-45053-7\\_8](https://doi.org/10.1007/978-3-319-45053-7_8)
- National Council of Supervisors of Mathematics. (1989). Essential mathematics for the twenty-first century: The position of the National Council of supervisors of mathematics. *Arithmetic Teacher*, 44–46.
- National Council of Teachers of Mathematics. (1980). *An agenda for action: Recommendations for school mathematics of the 1980s*. Author.
- National Council of Teachers of Mathematics (NCTM). (1989). *Curriculum and evaluation standards for school mathematics*. Author.
- National Council of Teachers of Mathematics (NCTM). (2000). *Principles and standards for school mathematics*. NCTM.
- National Research Council. (1979). *The Role of Applications in the Undergraduate Mathematics Curriculum*. The National Academies Press. <https://doi.org/10.17226/19835>
- National Research Council. (2001). *Adding it up: Helping children learn mathematics*. National Academy Press.
- NCTM. (2000). *Principles and standards for school mathematics*. NCTM.
- Nelson, D., et al. (1993). *Multicultural mathematics: Teaching mathematics from a global perspective*. *The Mathematical Gazette* (Vol.79. ERIC Number: ED365767). <https://eric.ed.gov/?id=ED365767>
- Neuendorf, K. A. (2002). *The content analysis guidebook*. Sage Publications.
- Neugebauer, O. (1957). *The exact sciences in antiquity*. Harper.
- Ng, O., Shi, L., & Ting, F. (2020). Exploring differences in primary students' geometry learning outcomes in two technology-enhanced environments: Dynamic geometry and 3D printing. *International Journal of STEM Education*, 7, 50. <https://doi.org/10.1186/s40594-020-00244-1>
- Niss, M., & Højgaard, T. (Eds.). (2011). Competencies and mathematical learning—ideas and inspiration for the development of mathematics teaching and learning in Denmark. *English Edition, October 2011. IMFUFA tekst no. 485*. Roskilde: Roskilde University (published in Danish in 2002).
- Nkogo, E. (2001). *Síntesis sistemática de la filosofía africana*. Ediciones Carena. <https://gratis.e-detective.de/descargar/233489-eugenio-nkogo/>
- Nordén, B. (2018). Transdisciplinary teaching for sustainable development in a WholeSchool project. *Environmental Education Research*, 24(5), 663–677.
- Noss, R., & Hoyles, C. (1996). *Windows on mathematical meanings learning cultures and computers*. Kluwer Academic Publishers.
- Noss, R., Healy, L., & Hoyles, C. (1997). The construction of mathematical meanings: Connecting the visual with the symbolic. *Educational Studies in Mathematics*, 33, 203–233. <https://doi.org/10.1023/A:1002943821419>
- Novotna, J., Margolinas, C., & Sarrazy, B. (2013). Developing mathematics educators. In M. A. Clements, A. J. Bishop, C. Keitel, J. Kilpatrick, & F. K. S. Leung (Eds.), *Third international handbook of mathematics education* (pp. 431–457). Springer.
- Núñez, P. (1567). *Libro de Algebra en Arithmetica y Geometria*. Herederos d'Arnoldo Birckman.
- O'Shea, T. (2016). *Mathematics education across time and place: Over two millennia from Athens to Zimbabwe*. FriesenPress. ISBN 978-1460286081.
- Oaks, J. A. (2019). Proofs and algebra in al-Fārisī's commentary. *Historia Mathematica*, 47, 106–121. <https://doi.org/10.1016/j.hm.2018.10.008>
- Oliveras, M. L., Blanco-Álvarez, H., & Palhares, P. (2013). ¿Hay matemáticas fuera de la escuela?: reflexiones de maestros de matemáticas en ejercicio. *Revista Científica*, Edición especial. 417–421.
- Olivero, F. (2002). *The proving process within a dynamic geometry environment*. PhD Thesis, University of Bristol.

- Olsher, S., Yerushalmy, M., & Chazan, D. (2016). How might the use of technology in formative assessment support changes in mathematics teaching? *For the Learning of Mathematics*, 36(3), 11–18.
- Orey, D. C., & Rosa, M. (2008). Ethnomathematics and cultural representations: Teaching in highly diverse contexts. *Acta Scientiae*, 10(1), 27–46.
- Orey, D., & Rosa, M. (2011). Ethnomodeling: A pedagogical action for uncovering ethnomathematical practices. *Journal of Mathematical Modelling and Application*, 1(3), 58–67.
- Organisation for Economic Co-operation and Development. (2006, May 4). *Evolution of student interest in science and technology studies policy report*. Global Science Forum. <https://www.oecd.org/science/inno/36645825.pdf>
- Osterroth, A. (2018). *Semiotics of Internet memes*. <https://doi.org/10.13140/RG.2.2.12320.89605>
- Padilla, P. (1756). *Curso militar de mathematicas, sobre las partes de estas ciencias, pertenecientes al Arte de la Guerra. Tomo 3*. Imprenta de Antonio Marin.
- Palenzuela, H. (2016–2017). *¿Por qué incluir la Historia de la Matemática en el aula?* Máster en Profesorado de Educación Secundaria Obligatoria y Bachillerato, Formación Profesional y Enseñanza de Idiomas, 4–12. Universidad de Almería (España).
- Palhares, P. (2012). Mathematics education and ethnomathematics. A connection in need of reinforcement. *REDIMAT – Journal of Research in Mathematics Education*, 1(1), 79–92.
- Panero, M., & Mamede, E. (2020). Mathematics teacher education/Éducation des enseignants en mathématiques. *Quaderni di Ricerca in Didattica (Mathematics)*, 25(2), 333–336.
- Pape, S. J., & Tchoshanov, M. A. (2001). The role of representation(s) in developing mathematical understanding. *Theory Into Practice*, 40(2), 118–127.
- Papert, S. (1980). *Mindstorms: Children, computers and powerful ideas*. Basic Books.
- Papert, S. (1986). *Constructionism: A new opportunity for elementary science education*. A proposal to the National Science Foundation, Massachusetts Institute of Technology, Media Laboratory, Epistemology and Learning Group.
- Papert, S. (1990). *Computer criticism vs technocentrism* (E&L Memo n° 01). Massachusetts Institute of Technology. Media Laboratory.
- Papert, S. (1994). *A máquina das crianças: repensando a escola na era da informática*. Artes Médicas.
- Papert, S. (1999). What is logo? Who needs it In *Logo philosophy and implementation* (pp. 4–16).
- Papert, S. & Solomon, C. (1971). *Twenty things to do with a computer* (Logo Memo N° 3). <http://www.stager.org/articles/twentythings.pdf>.
- Paradis, J., & Malet, A. (1989). *La génesis del álgebra simbólica. Vol. 1. Los orígenes del álgebra: de los árabes al Renacimiento*. Promociones y Publicaciones Universitarias.
- Páramo, G. (1996). Mito, lógica y geometría. En: C.B. Gutiérrez. (Ed.). *El trabajo filosófico de hoy en el continente*. Memorias del XIII Congreso Interamericano de Filosofía. Bogotá. Universidad de los Andes.
- Parshall, K. H. (2017). A plurality of algebras, 1200–1600: Algebraic Europe from Fibonacci to Clavius. *BSHM Bulletin: Journal of the British Society for the History of Mathematics*, 32(1), 2–16. <https://doi.org/10.1080/17498430.2016.125340>
- Pascal, B. (1645). *Lettre dédicatoire à Monseigneur le chancelier*. No printing or printer's name, retrieved on June 2022 the 13th from <http://www.bibnum.education.fr/calculinformatique/calcul/la-pascaline-la-machine-qui-releve-du-defaut-de-la-memoire>
- Patrick, S. (2008). ICT in educational policy in the North American region. In *International handbook of information technology in primary and secondary education* (pp. 1109–1117). Springer.
- Paulo, R. M., Pereira, A. L., & Pavanelo, E. (2020). The constitution of mathematical knowledge with augmented reality. *The Mathematics Enthusiast (TME)*, 18(3), 640–668. Retrieved from <https://scholarworks.umt.edu/tme/vol18/iss3/11>
- Pekrun, R., & Linnenbrink-Garcia, L. (2014). *International handbook of emotions in education*. Routledge.

- Peña, P., & Hueitra, Y. (2016). Conocimientos [matemáticos] mapuche desde la perspectiva de los educadores tradicionales de la comuna de El Bosque. *Revista Latinoamericana de Etnomatemática*, 9(1), 8–25.
- Pengelley, D. (2011). Teaching with primary historical sources: Should it go mainstream? Can it? In V. Katz & C. Tzanakis (Eds.), *Recent developments on introducing a historical dimension in mathematics education* (pp. 1–8). The Mathematical Association of America. <https://doi.org/10.5948/upo9781614443001.002>
- Penglase, M., & Arnold, S. (1996). The graphics calculator in mathematics education: A critical review of recent research. *Mathematics Education Research Journal*, 8(1), 58–90.
- Pepin, B., & Roesken-Winter, B. (Eds.). (2014). *From beliefs to dynamic affect systems in mathematics education: Exploring a mosaic of relationships and interactions*. Springer.
- Perdomo Díaz, J., & Fernández Vizcarra, A. (2018). Estudio exploratorio de las emociones en la cotidianidad de las clases de matemáticas. *Revista Electrónica de Investigación Educativa*, 20(4), 133–143.
- Pereira Gonçalves, C. V., & Gomes, A. (2020). Portuguese school teachers' mathematical knowledge for teaching: Questions on numbers and operations. *Quaderni di Ricerca in Didattica (Mathematics)*, 7(special issue), 193–198.
- Perez de Moya, J. (1562). *Arithmetica practica, y specvlativa*. Mathias Gast.
- Perez de Moya, J. (1573). *Tratado de Mathematicas*. Juan Gracian.
- Philipp, R. A. (2007). Mathematics teachers' beliefs and affect. In F. K. J. Lester (Ed.), *Second handbook of research on mathematics teaching and learning* (pp. 257–315) National Council of Teachers of Mathematics.
- Philippou, G. N., & Christou, C. (1998a). Beliefs, teacher education and history of mathematics. In A. Olivier & K. Newstead (Eds.), *Proceedings of PME 22* (Vol. 4, pp. 1–9).
- Philippou, G. N., & Christou, C. (1998b). The effect of a preparatory mathematics program in changing prospective teachers' attitudes towards mathematics. *Educational Studies in Mathematics*, 35, 189–206. <https://doi.org/10.1023/A:1003030211453>
- Piaget, J. (1978). *Investigaciones sobre la contradicción*. Siglo Veintiuno.
- Piaget, J. (1985). *Equilibration of cognitive structures*. University of Chicago Press.
- Ping, O. W., & Hua, A. K. (2016). A case report of educational in 3D and 2D towards primary mathematics. *Asia Pacific Journal of Education. Arts and Science*, 3(2), 8–12. <https://doi.org/10.6084/m9.figshare.3398614.v1>
- Pinnika, V., Moutsios-Rentzos, A., & Kalavasis, F. (2018). A systemic approach to the image for mathematics: The case of special education. In B. Maj-Tatsis, K. Tatsis, & E. Swoboda (Eds.), *Mathematics in the real world* (pp. 261–270). Wydawnictwo Uniwersytetu Rzeszowskiego. isbn:978-83-7996-554-0.
- Pino-Fan, L. R., Godino, J. D., & Font, V. (2018). Assessing key epistemic features of didactic-mathematical knowledge of prospective teachers: The case of the derivative. *Journal of Mathematics Teacher Education*, 21(1), 63–94. <https://doi.org/10.1007/s10857-016-9349-8>
- Pinto, H., & Costa, C. (2020). La Historia de las Matemáticas en los Cursos de Educación Básica en Portugal: una Reflexión para la Formación del Profesorado. *Paradigma. Revista del centro de investigaciones educacionales*, 41(1), 1–19.
- Pinto Sosa, J. E., & González Astudillo, M. T. (2008). El conocimiento didáctico del contenido en el profesor de matemáticas: ¿una cuestión ignorada? *Educación Matemática*, 20(3), 83–100.
- Poisson, S. D. (1781–1840). <https://mathshistory.st-andrews.ac.uk/Biographies/Poisson/>
- Pollack, H. (1969). How can we teach applications of mathematics? *Educational Studies in Mathematics*, 2(2/3), 393–404.
- Pólya, G. (1957). *How to solve it*. Anchor Books.
- Polya, G., & Szego, G. (1972). *Problems and theorems in Analysis*. Springer-Verlag.
- Ponte, J. (2007). Investigations and explorations in the mathematics classroom. *ZDM Mathematics Education*, 39, 419–430. <https://doi.org/10.1007/s11858-007-0054-z>

- Ponte, J. P., & Chapman, O. (2008). Preservice mathematics teachers' knowledge and development. In L. D. English (Ed.), *Handbook of international research in mathematics education* (2nd ed., pp. 223–261). Routledge.
- Ponte, J. P., & Santos, L. (2005). A distance in-service teacher education setting focused on mathematics investigations: The role of reflection and collaboration. *Interactive Educational Multimedia*, 11, 104–126. <http://hdl.handle.net/10451/4072>
- Ponte, J. P., Serrazina, L., Guimarães, H. M., Breda, A., Guimarães, F., Martins, M. E. G., Menezes, L., Oliveira, P., & Sousa, H. (2007). *Programa de Matemática do Ensino Básico*. <http://hdl.handle.net/10400.19/1155>
- Powell, A. B. (1997). In M. Frankenstein (Ed.), *Ethnomathematics: Challenging eurocentrism in mathematics education*. SUNY Press.
- Poy y Comes, M. (1786). *Elementos de aritmetica y algebra para la instruccion de la juventud*. Francisco Suria y Burgada.
- Poy y Comes, M. (1790). *Llave aritmetica y algebrayca*. Francisco Suriá y Burgada.
- Prado, M. E. B. B., & Lobo da Costa, M. N. (2015). Educational laptop computers integrated into mathematics classrooms. In U. Gellert, J. Giménez Rodríguez, C. Hahn, & S. Kafoussi (Eds.), *Educational paths to mathematics: A C.I.E.A.E.M sourcebook* (pp. 351–365). Springer.
- Prado, M. E. B. B., & Valente, J. A. (2003). A formação na ação do professor: Uma abordagem na e para uma nova prática pedagógica. In J. A. Valente (Ed.), *Formação de educadores para o uso da Informática na escola* (pp. 21–38). Campinas, SP. <https://www.nied.unicamp.br/biblioteca/formacao-de-educadores-para-o-uso-da-informatica-na-escola/>
- Prado, M. E. B. B., Dias, F. A. S., & Padilha, W. R. (2018). O processo de apropriação das tecnologias digitais móveis: uma experiência na formação continuada do professor de matemática. *Educação & Linguagem (online)*, 21, 41–58.
- Prado, M. E. B. B., Garcia Silva, A. F., Pietropaolo, R. C., & Silva, S. F. K. (2020). Pensamento Computacional e atividade de programação: perspectivas para o ensino da matemática. *Revista Sergipana de Matemática e Educação Matemática.*, 5(2), 145–208.
- Prats, J., & Santacana, J. (2009). La ciudad, un espacio para aprender. *Aula de innovación educativa*, 182, 47–51.
- Presmeg, N. (2007). The role of culture in teaching and learning mathematics. *Second Handbook of Research on Mathematics Teaching and Learning*, 1, 435–458.
- Pressman, I., & Singmaster, D. (1989). “The jealous husbands” and the “missionaries and cannibals”. *The Mathematical Gazette*, 73(464), 73–81.
- Prosperini, L., & Isonni, B. (2000). *Storie di matematica*. Ghisetti e Corvi Editori.
- Puig, A. (1672). *Arithmetica especulativa, y practica y arte de algebra*. Antonio Lacavalleria.
- Puig, L. (2003). Historia de las ideas algebraicas: componentes y preguntas de investigación desde el punto de vista de la matemática educativa. In E. Castro (Ed.), *Investigación en educación matemática: séptimo Simposio de la Sociedad Española de Investigación en Educación Matemática* (pp. 97–108). SEIEM. <https://www.uv.es/puigl/granada03oral.pdf>
- Puig, L. (2022). Ideas of structure in the history of algebra and its teaching. In T. Rojano (Ed.), *Algebra structure sense development among diverse learners* (pp. 20–35). Routledge. <https://doi.org/10.4324/9781003197867>
- Puig, L., & Fernández, A. (2013). La Arithmetica Algebraica de Marco Aurel, primer álgebra impresa escrita en español. Preliminares para su estudio. In L. Rico, M. C. Cañadas, J. Gutiérrez, M. Molina, & I. Segovia (Eds.), *Investigación en Didáctica de la Matemática. Homenaje a Encarnación Castro* (pp. 143–150). Editorial Comares.
- Puig, L., & Rojano, T. (2004). The history of algebra in mathematics education. In K. Stacey, H. Chick, & M. Kendal (Eds.), *The future of the teaching and learning of algebra the 12th ICMI study* (pp. 187–223). Kluwer Academic Publishers. [https://doi.org/10.1007/1-4020-8131-6\\_8](https://doi.org/10.1007/1-4020-8131-6_8)
- Punie, Y., Zinnbauer, D., & Cabrera, M. (2006). A review of the impact of ICT on learning. *European Commission, Brussels*, 6(5), 635–650.
- Qiu, J. L., & Bu, W. (2013). China ICT studies: A review of the field, 1989–2012. *The China Review*, 13(2), 123–152.

- Quijano, M., & Corica, A. R. (2017). Development of a reference Praxeological model about loci. *Redimat*, 6(2), 192–220. <https://doi.org/10.17583/redimat.2017.2228>
- Quinn, A. (2015). Using apps to visualize graph theory. *The Mathematics Teacher*, 108(8), 626–631.
- Rabardel, P. (1995). *Les hommes et les technologies, approche cognitive des instruments Contemporains*. Armand Colin. HAL: hal-01017462, Consulted 5 April 2016.
- Radford, L. (1997). On psychology, historical epistemology, and the teaching of mathematics: Towards a socio-cultural history of mathematics. *For the Learning of Mathematics*, 17(1), 26–33.
- Radford, L. (1998). *On culture and mind, a post-Vygotskian semiotic perspective, with an example from Greek mathematical thought*. Paper presented at the 23rd annual meeting of the semiotic society of America, Victoria College, University of Toronto, October 15–18, 1998. Retrieved from <http://www.laurentian.ca/educ/lradford/>
- Radford, L. (2006). Elementos de una teoría cultural de la objetivación. *Revista Latinoamericana de Investigación en Matemática Educativa* (Special Issue on Semiotics, Culture and Mathematical Thinking).
- Radford, L. (2008). The ethics of being and knowing: Towards a cultural theory of learning. In L. Radford, G. Schubring, & F. Seeger (Eds.), *Semiotics in mathematics education: Epistemology, history, classroom, and culture*. Sense Publishers.
- Radford, L. (2010). Layers of generality and types of generalization in pattern activities. *PNA*, 4(2), 37–62.
- Radford, L. (2013). Three key concepts of the theory of objectification: Knowledge, knowing, and learning. *Redimat*, 2(1), 7–44. <https://doi.org/10.4471/redimat.2013.19>
- Radford, L. (2016). Mathematics education as a matter of labor. In M. A. Peters (Ed.), *Encyclopedia of educational philosophy and theory*. [Living edition]. Springer. [https://doi.org/10.1007/978-981-287-532-7\\_518-1](https://doi.org/10.1007/978-981-287-532-7_518-1)
- Radford, L. (2021). *The theory of objectification. A Vygotskian perspective on knowing and becoming in mathematics teaching and learning*. Brill.
- Radford, L., Furinghetti, F., & Katz, V. (2007). Introduction: The topos of meaning or the encounter between past and present. *Educational Studies in Mathematics*, 66(1), 107–110. <https://doi.org/10.1007/s10649-006-9076-7>
- Ramírez, A. V. (2009). La teoría del conocimiento en investigación científica: una visión actual (Knowledge's theory in scientific research: a current scope). American College of Occupational and Environmental Medicine. *Anales de la Facultad de Medicina*, 70(3), 217–242.
- Ramos, J. L., & Espadeiro, R. G. (2014). Os futuros professores e os professores do futuro. Os desafios da introdução ao pensamento computacional na escola, no currículo e na aprendizagem. *Educação, Formação & Tecnologias*, 7(2), 4–25.
- Rankin, J. (2018). *A people's history of computing in the United States*. Harvard University Press.
- Raum, O. (1938). *Arithmetic in Africa*. Evans Brothers.
- Reimers, F. M. (Ed.). (2022). *Primary and secondary education during COVID-19*. Springer.
- Reisch, G. (1503). *Margarita philosophica*. Digitalized retrieved on June 2022 the 13th from <https://daten.digitale-sammlungen.de/0001/bsb00012346/images/index.html>
- Resnick, M., Maloney, J., Monroy-Hernández, A., Rusk, N., Eastmond, E., Brennan, K., Millner, A., Rosenbaum, E., Silver, J., Silverman, B., & Kafai, Y. (2009a). Scratch: Programming for all. *Communications of the ACM*, 52(11), 60–67.
- Resnick, M., et al. (2009b). Scratch: Programming for all. *Communications of the ACM*, 52(11), 60–67.
- Resolución 217-III. (1948). *Universal Declaration of Human Rights (UDHR)* (pp. 34–38). [https://undocs.org/es/A/RES/217\(III\)](https://undocs.org/es/A/RES/217(III))
- Rey, J. (1934). *Los matemáticos españoles del siglo XVI*. Junta de Investigaciones Histórico-Bibliográficas.
- Reyes, L. H. (1984). Affective variables and mathematics education. *The Elementary School Journal*, 84, 558–581. <https://doi.org/10.1086/461384>

- Reynolds-Case, A. (2013). The value of short-term study abroad: An increase in students' cultural and pragmatic competency. *Foreign Language Annals*, 46(2), 311–322.
- Richards, J. (1991). Mathematical discussions. In E. Von Glasersfeld (Ed.), *Radical constructivism in mathematics education. Mathematics education library* (Vol. 7, pp. 13–51). Springer. [https://doi.org/10.1007/0-306-47201-5\\_2](https://doi.org/10.1007/0-306-47201-5_2)
- Richstein, J. (2001). Verifying the Goldbach conjecture up to  $4 \times 10^{14}$ . *Mathematics of Computation*, 70(236), 1745–1749. <https://www.ams.org/journals/mcom/2001-70-236/S0025-5718-00-01290-4/>
- Ricoeur, P. (1986). Rhétorique-Poétique-Herméneutique. In M. Meyer (Ed.), *De la métaphysique à la rhétorique* (pp. 143–155). Université de Bruxelles.
- Roberts, D. L. (2014). History of tools and technologie in mathematics. In A. Karp & G. Schubring (Eds.), *Handbook on the history of mathematics education* (pp. 565–578). Springer.
- Robutti, O. (2010). Graphic calculators and connectivity software to be a community of mathematics practitioners. *ZDM – The International Journal on Mathematics Education*, 42(1), 77–89.
- Robutti, O., et al. (2016). ICME international survey on teachers working and learning through collaboration: June 2016. *ZDM-Mathematics Education*, 48, 651–690. <https://doi.org/10.1007/s11858-016-0797-5>
- Rocard, M., Csermely, P., Jorde, D., Lenzen, D., Walberg-Heriksson, H., & Hemmo, V. (2007). *Science education now: A new pedagogy for the future of Europe*. Report for the European Commission. <https://www.eesc.europa.eu/sites/default/files/resources/docs/rapportrocardfinal.pdf>
- Rocha, A. (1564). *Arithmetica* (1st ed.). Casa de Claudio Bornat a la Águila Fuerte.
- Rocha, A. K. d. O., Prado, M. E. B. B., & Valente, J. A. (2020). A linguagem de programação Scratch na formação do professor: uma abordagem baseada no TPACK. *Revista Sergipana de Matemática e Educação Matemática*, 5(2), 19–36.
- Rodríguez, M. E., & Mosqueda, K. (2015). Aportes de la pedagogía de Paulo Freire en la enseñanza de la matemática: hacia una pedagogía liberadora de la matemática. *Revista Educación y Desarrollo Social*, 9(1), 82–95. Bogotá (Colombia).
- Roesken-Winter, B., Hoyles, C., & Blömeke, S. (2015). Evidence-based CPD: Scaling up sustainable interventions. *ZDM-Mathematics Education*, 47, 1–12. <https://doi.org/10.1007/s11858-015-0682-7>
- Romero, S. (2011). La resolución de problemas como herramienta para la modelización matemática. *Modelling in Science Education and Learning. Volume 4, No. 4. Instituto Universitario de Matemática Pura y Aplicada*. Valencia, 41–47.
- Romero, S. (2016). Situaciones reales. . .SAPERE AUDE a través de la Modelización Matemática. *Proceedings XVI CEAM. Conferencia Clausura*. <https://thales.cica.es/xviceam/actas/pdf/actas.pdf>
- Romero S. (2019). An introduction to the theory of complexity: case study with dynamic systems and fractality. *Proceedings CIEAEM-71. Quaderni di Ricerca in Didattica*. [http://math.unipa.it/~grim/quaderno\\_2020\\_numspecc\\_7.htm](http://math.unipa.it/~grim/quaderno_2020_numspecc_7.htm)
- Romero, S. (2020a). An introduction to the theory of complexity: A case study with dynamic systems and fractality. *Quaderni di Ricerca in Didattica (Mathematics)*, Número Speciale, 7, 127–138. G.R.I.M. Dipartimento di Matematica, University of Palermo.
- Romero, S. (2020b) Algunas reflexiones sobre la divulgación del conocimiento científico. *Encuentro entre Academias Americanistas Andaluzas. Instituto de Academias de Andalucía. Consejería de Economía, Conocimiento, Empresas y Universidad* (pp. 41–43). Junta de Andalucía. Málaga (España).
- Romero, S., & Benítez, R. (2008). De la Jungla de Cristal III a las ecuaciones diofánticas pasando por el algoritmo de Euclides. *Rev. Epsilon: Revista de la Sociedad Andaluza de Educación Matemática "Thales"*, 7–26. (Page on the synopsis of the film The Crystal Jungle III). <http://www.filmaffinity.com/es/film971189.html>. <http://www.hoycinema.com/Jungla-cristal-III-vinganza-1995.html>



- Romero, S., & Benítez, R. (2021a, 2022). Gestión del talento matemático en tiempos de incertidumbre-COVID19- en alumnos de Enseñanza Secundaria Obligatoria en un centro ERASCIS (Estrategia Regional Andaluza para la Cohesión e Inclusión Social). En: *Modalidad C: proyectos que impulsen la colaboración con centros docentes públicos no universitarios*. [https://www.uhu.es/innovacion\\_docente/ConvPID\\_2021\\_2022/RESOLUCION\\_DEFINITIVA\\_21\\_22.pdf](https://www.uhu.es/innovacion_docente/ConvPID_2021_2022/RESOLUCION_DEFINITIVA_21_22.pdf)
- Romero, S., & Benítez, R. (2021b). Proyecto TOCAR LAS MATES-YO TUVE CIENCIA (2021). Activity framed in the dissemination of research carried out at the University of Huelva for young people. Consejería de Transformación Económica, Industria, Conocimiento y Universidades. OTRI. University of Huelva. European Union. Regional Development Fund. <https://www.youtube.com/watch?v=ZHYDNzxpmg>
- Romero, S., & Romero, J. (2015). ¿Por una enseñanza problematizada y modelizada de las matemáticas? Estudio de casos. *Uno: Revista de didáctica de las matemáticas*, 69, 33–43.
- Romero, S., Rodríguez, I.M., Salas, I.M., Benítez, R., & Romero, J. (2014). La Resolución de Problemas (RdP's) como herramienta para la modelización matemática: ejemplos de la vida real. *IV Jornadas sobre Modelización MATEMÁTICA. Matemáticas a lo largo de la vida*. Universidad Internacional de Andalucía. Palos de la Frontera (Huelva).
- Rosa, M., & Orey, D. C. (2011). Ethnomathematics: The cultural aspects of mathematics. *Revista Latinoamericana de Etnomatemática*, 4(2), 32–54.
- Rosa, M., & Orey, D. C. (2016a). State of the art in Ethnomathematics. In *Current and future perspectives of ethnomathematics as a program* (pp. 11–37). Springer.
- Rosa, M., & Orey, D. (2016b). Ethnomodelling as a globalization process of mathematical practices through cultural dynamism. *The Mathematics Enthusiast*, 18(3), 439–468.
- Rosa, M., & Shirley, L. (2016). Introduction. In M. Rosa, U. D'Ambrosio, D. Clark, L. Shirley, W. V. Alangui, P. Palhares, & M. E. Gavarrete (Eds.), *Current and future perspectives of Ethnomathematics as a program* (ICME-13 Topical Surveys). Springer. [https://doi.org/10.1007/978-3-319-30120-4\\_2](https://doi.org/10.1007/978-3-319-30120-4_2)
- Rosell, A. G. (1785). *Instituciones matemáticas. Tomo I*. Imprenta Real.
- Roth, W. M., & Radford, L. (2011). *A cultural-historical perspective on mathematics teaching and learning. Computer science, mathematics*. <https://www.appf.edu.es/ensenanza-para-todas-las-culturas/>
- Rouse Ball, W. W. (1960). *A short account of the history of mathematics*. Dover.
- Rowland, T., Huckstep, P., & Thwaites, A. (2003). The knowledge quartet. In *Proceedings of the British Society for Research into Learning Mathematics* (pp. 97–102).
- Ruiz-Higueras, L., Estepa, A., & García, J. (Eds.). (2007). *Sociedad, Escuela y Matemáticas. Aportaciones de la Teoría Antropológica de lo Didáctico (TAD)*. Universidad de Jaén.
- Ruthven, K. (1996). Calculators in the mathematics curriculum: The scope of personal computational technology. In *International handbook of mathematics education* (pp. 435–468). Springer.
- Sáenz, C. (2001). Sobre conjeturas y demostraciones en la enseñanza de las matemáticas. In *V Simposio de la Sociedad Española de Investigación en Educación Matemática* (pp. 47–51). Almería.
- Said, E. (1978). *Orientalism: Western concepts of the orient*. Pantheon Books.
- Sala, G., Giménez, J., & Font, V. (2013). *Alumnos de Primaria investigan sobre la numeración. Jornadas para la enseñanza y aprendizaje de las matemáticas*. XVI JAEM.
- Salazar, M. J. (2009). *Multiculturalidad e interculturalidad en el ámbito educativo: experiencia de países latinoamericanos* (pp. 13–26). IIDH. Instituto interamericano de Derechos Humanos.
- Sámuel, M., Vanegas, Y., & Giménez, J. (2018). Caracterización del conocimiento matemático de futuras maestras de educación infantil. *Bordón*, 70(3), 61–75. <https://doi.org/10.13042/Bordon.2018.62907>
- Sandholtz, J. H., Ringstaff, C., & Dwyer, D. C. (1997). *Ensinando com Tecnologia: criando salas de aula centradas no aluno*. Artes Médicas.

- Sangiaco, L. (1996). *O Processo da Mudança de Estatuto: de desenho para figura geométrica*. Thesis, Master in Mathematic Teaching. Pontifícia Universidade Católica de São Paulo – PUCSP.
- Schacter, S., & Singer, J. (1962). Cognitive, social and physiological determinants of emotional state. *Psychological Review*, 69, 379–399. <https://doi.org/10.1037/h0046234>
- Scheler, M. (1934). El saber y la cultura. *Revista de Occidente*. En *Colección: Nuevos Hechos-Nuevas Ideas IX*. <https://archive.org/details/scheler-max-el-saber-y-la-cultura-ocr-1939/page/n1/mode/2up>
- Schleicher, A. (Ed.). (2012). *Preparing teachers and developing school leaders for the 21st century: Lessons from around the world*. OECD Publishing.
- Schmidt, M. (1991). Aproximaciones diofánticas y ecuaciones diofánticas. In *Apuntes de clase en Matemáticas* (Vol. 1467). Springer.
- Schoenfeld, A. H. (1985). *Mathematical problem solving*. Academic.
- Schoenfeld, A. (1992). Learning to think mathematically: Problem solving, metacognition, and sense making in mathematics. In D. A. Grouws (Ed.), *Handbook of research on mathematics teaching and learning* (pp. 165–197). Macmillan.
- Schrader, D. V. (1967). The arithmetic of the medieval universities. *The Mathematics Teacher*, 60(3), 264–278.
- Schubring, G., et al. (2000). History of mathematics for trainee teachers. In J. Fauvel & J. Van Maanen (Eds.), *History in mathematics education, the ICMI study* (pp. 91–142). Springer.
- Schwartz, B., Dreyfus, T., & Brukheimer, M. (1990). A model of the function concept in a three-fold representation. *Computers Education*, 14(3), 249–262.
- Scott, D. (2006). *Plato's Meno*. Cambridge University Press.
- Scriba, C. J., & Schreiber, P. (2010). *5000 years of geometry: Mathematics in history and culture*. Springer. ISBN: 978-3-0348-0898-9.
- Seah, W. T., Atweh, B., Clarkson, P., & Ellerton, N. (2008). Socio-cultural factors in mathematics teaching and learning. In H. Forgasz, A. Barkatsas, A. Bishop, B. Clarke, S. Keast, W. T. Seah, & P. Sullivan (Eds.), *Research in mathematics education in Australasia 2004–2007* (pp. 223–253). Sense Publishers.
- Seifert, M., Egert, M., Heerbaart, F., Kolossa, K., Limanski, M., & Mumin, M. (2006). Fostering ICT use in teacher education, in Africa. In *1st Cologne Junior Conference on African Studies (KANT I)*. [http://www.uni-koeln.de/phil-fak/afrikanistik/kant/data/AMI\\_kant1.pdf](http://www.uni-koeln.de/phil-fak/afrikanistik/kant/data/AMI_kant1.pdf)
- Sensevy, G. (2011). Overcoming fragmentation: Towards a joint action theory in didactics. In B. Hudson & M. Meyer (Eds.), *Beyond fragmentation: Didactics, learning and teaching in Europe* (pp. 60–76). Barbara Budrich.
- Serradó, A., Vanegas, Y. M., & Giménez, J. (2015). Facilitating deliberate dialogue in mathematics classroom. In U. Gellert et al. (Eds.), *Educational paths to mathematics* (Advances in Mathematics Education) (pp. 289–304). Springer.
- Serres, M. (2019). *Hominescence*. Bloomsbury.
- Sesiano, J. (2021). Diophantus. *Encyclopedia Britannica*, 25. <https://www.britannica.com/biography/Diophantus>
- Sfard, A. (1995). The development of algebra: Confronting historical and psychological perspectives. *Journal of Mathematical Behaviour*, 14, 15–39.
- Sfard, A. (2001). Learning mathematics as developing a discourse. In *Proceedings of 21st conference of PME-NA* (pp. 23–44).
- Sfard, A. (2004). What could be more practical than good research? On mutual relations between research and practice of mathematics education. In M. Niss (Ed.), *Proceedings of the 10th international congress on mathematical education* (pp. 76–91).
- Shannon, C. E. (1948). A mathematical theory of communication. *The Bell System Technical Journal*, 27(3), 379–423.
- Shell-Gellasch, A. (Ed.). (2008). *Hands-on history: A resource for teaching mathematics*. Mathematical Association of America.

- Shell-Gellasch, A., & Jardine, D. (Eds.). (2005). *From calculus to computers: Using the last 200 years of mathematics history in the classroom* (MAA notes) (Vol. 68). The Mathematical Association of America.
- Shifman, L. (2014). *Memes in digital culture*. MIT Press.
- Shkelzen, H. (2017a). Multiculturalism vs Interculturalism: New Paradigm? (Sociologic and Juridical Aspects of the Debate between the two Paradigms)? University of Pisa Italy. *Journal of Education & Social Policy*, 4, 171–172.
- Shkelzen, H. (2017b). Multiculturalism vs interculturalism: New paradigm? (sociologic and juridical aspects of the debate between the two paradigms). *Journal of Education & Social Policy*, 4(2), 171–179.
- Shulman, L. S. (1986). Those who understand: Knowledge growth in teaching. *Educational Researcher*, 15(2), 4–14. <https://doi.org/10.3102/0013189X015002004>
- Shulman, L. (1987). Knowledge and teaching: Foundations of the new reform. *Harvard Educational Review*, 57(1), 1–23. <https://doi.org/10.17763/haer.57.1.j463w79r56455411>
- Shumway, R. J., Wheatley, G. H., Coburn, T. G., White, A. L., Revs, R. E., & Schoen, H. L. (1981). Initial effect of calculators in elementary school mathematics. *Journal for Research in Mathematics Education*, 12(2), 119–141.
- Sidericoudes, O. (1996). *Desenvolvimento de Metodologias de Ensino-Aprendizagem da Matemática em Ambientes Computacionais Baseados na Estética Logo*. Thesis, Master in Mathematic Education. Universidade Paulista de São Paulo – UNESP/Rio Claro.
- Sierra, M. (1997). Notas de Historia de las Matemáticas para el currículo de secundaria. En L. Rico (Coord.), E. Castro, E. Castro, M. Coriat, A. Marín, L. Puig, M. Sierra y M. Socas (Eds.), *La educación matemática en la enseñanza secundaria* (pp. 179–194). ICE-Horsori.
- Silva, M. C. (1997). *Teorema de Thales: Uma Engenharia Didática utilizando o Cabri Geometre*. Thesis, Master in Mathematic Teaching. Pontifícia Universidade Católica de São Paulo – PUCSP.
- Silver, E. A. (1997). Fostering creativity through instruction rich in mathematical problem solving and problem posing. *ZDM-Mathematical Education*, 29(3), 75–80. <https://doi.org/10.1007/s11858-997-0003-x>
- Simon, H. A. (1967). Motivational and emotional controls of cognition. *Psychological Review*, 74, 29–39. <https://doi.org/10.1037/h0024127>
- Sinko, M., & Lehtinen, E. (1999). *The challenges of ICT*. Atena.
- Sisman, G. T., & Aksu, M. (2016). A study on sixth grade students' misconceptions and errors in spatial measurement: Length, area, and volume. *International Journal of Science and Mathematics Education*, 14, 1293–1319. <https://doi.org/10.1007/s10763-015-9642-5>
- Siu, M. K. (1997). *The ABCD of using history of mathematics in the (undergraduate) classroom*. *Bulletin of Hong Kong Mathematical Society* (pp. 1–4, 12). Department of Mathematics University of Hong Kong. <https://citeseerx.ist.psu.edu/viewdoc/download?doi=10.1.1.563.1225&rep=rep1&type=pdf>
- Siu, M. K. (2007). No, I don't use history of mathematics in my class. Why? In F. Furinghetti, S. Kaijser, & C. Tzanakis (Eds.), *Proceedings HPM2004 & ESU4* (pp. 268–277). Uppsala Universitet.
- Siu, F. K., & Siu, M. K. (1979a). History of mathematics and its relation to mathematical education (1979). *International Journal of Mathematical Education in Science and Technology*, 10(4), 561–567. <https://eric.ed.gov/?id=EJ216698>
- Siu, F.-K., & Siu, M.-K. (1979b). History of mathematics and its relation to mathematical education. *International Journal of Mathematical Education in Science and Technology*, 10(4), 561–567.
- Siu, M.-K., & Tzanakis, C. (Eds.). (2004). The role of the history of mathematics in mathematics education. *Med JRME*, 3(1–2), 1–166.
- Skemp, R. R. (1976). Relational understanding and instrumental understanding. *Mathematics Teaching*, 77, 20–26.

- Skinner, B. (1965). Reflections on a decade of teaching machines. In R. Glaser (Ed.), *Teaching machines and programmed learning. II, data and directions* (pp. 5–20). National Education Association of the United States.
- Skovsmose, O., & Valero, P. (2007). Educación matemática y justicia social: hacerle frente a las paradojas de la sociedad de la información. En: J. Jiménez, J. Díez-Palomar y M. Civil (Eds.), *Educación matemática y exclusión*, Barcelona. Ed. Grao.
- Skovsmose, O., & Vithal, R. (1997). The end of innocence: A critique of ‘ethnomathematics’. *Educational Studies in Mathematics*, 3(2), 131–157.
- Smestad, B., Jankvist, U. T., & Clark, K. (2014). Teachers’ mathematical knowledge for teaching in relation to the inclusion of history of mathematics in teaching. *Nordic Studies in Mathematics Education*, 19(3–4), 169–183.
- Smith, D. E. (1902). *The teaching of elementary mathematics*. The Macmillan Company.
- Smith, D. E. (1958). *History of mathematics* (Vol. II). Dover.
- Smith, B. A. (1996). *A meta-analysis of outcomes from the use of calculators in mathematics education*. Texas A&M University-Commerce.
- Solar, H., & Deulofeu, J. (2014). *Tratamiento de la contingencia desde el desarrollo de la competencia de argumentación en el aula de matemáticas*. <http://funes.uniandes.edu.co/5389/>
- Soldano, C., & Arzarello, F. (2017). Learning with the logic of inquiry: Game-activities inside dynamic geometry environments. In T. Dooley & G. Guedet (Eds.), *Proceeding of CERME 10* (pp. 267–274). DCU Institute of Education & ERME.
- Soldano, C., & Sabena, C. (2019). Fostering critical thinking in primary school within dynamic geometry environments. In B. Di Paola, Y. Aberkane, & F. Cerquetti (Eds.), *Proceedings of CIEAEM 70. “Quaderni di Ricerca in Didattica (Mathematics)”*, n. 2, *Supplemento n.3* (pp. 73–79). Mostaganem (Algeria).
- Soldano, C., Luz, Y., Arzarello, F., & Yerushalmy, M. (2019). Technology-based inquiry in geometry: Semantic games through the lens of variation. *Educational Studies in Mathematics*, 100(1), 7–23.
- Solomon, C., Harvey, B., Kahn, K., Lieberman, H., Miller, M., Minsky, M., Papert, A., & Silverman, B. (2020). *History of Logo*. Proceedings of the ACM Programming Languages 4, HOPL, Article 79.
- Souza, V. H. G., Lima, R. N., Campos, T. M. M., & Gerardini, L. (2012). Mathematical modelling and bank loan systems: An experience with a group of young and adults. *Quaderni di Ricerca in Didattica (Mathematics)*, 22(1), 104–108.
- Spengler, O. (1918). *The decline of the west in the early 20<sup>th</sup> century*. Oxford.
- Spengler, O. (1956). Meaning of numbers. In J. Newman (Ed.), *The world of mathematics* (pp. 2315–2347). Simon and Schuster, ed. Newman.
- Stan, C. (2020). Multiculturality and interculturality in the educational system. *Educatia 21 Journal*, 19, 149–153. <http://educatia21.reviste.ubbcluj.ro/data/uploads/article/2020ed21-no19-art19.pdf>
- Stathopoulou, C. (2005). *Ethnomathematics: Exploring the cultural dimension of mathematics and of mathematics education*. Atrapos.
- Stathopoulou, C. (2006). Exploring informal mathematics of craftsmen in the designing tradition of ‘Xysta’ at Pyrgi of Chios. *For the Learning of Mathematics*, 26(3), 9–14.
- Stathopoulou, C., & Appelbaum, P. (2019). Mathematics education and Ethnomathematics – Living together with each other. *Quaderni di Ricerca in Didattica (mathematics). G.R.I.M. (Departimento di Matematica e Informatica)* (pp. 49–61). University of Palermo.
- Stathopoulou, C., & Kalabasis, F. (2002). Teaching mathematics to first grade Romany children, through familiar every day money dealings. In P. Volero & O. Skovsmose (Eds.), *Proceedings of the mathematics education and society conference* (pp. 507–514). Danmarks Paedagogiske Universitet.
- Stein, M. K., Engle, R. A., Smith, M. S., & Hughes, E. K. (2008). Orchestrating productive mathematical discussions: Five practices for helping teachers move beyond show and tell. *Mathematical Thinking and Learning*, 10, 313–340.
- Stillwell, J. (1989). *Mathematics and its history*. Springer.

- Streefland, L. (Ed.). (1991). *Realistic mathematics education in primary school*. Freudenthal Institute.
- Struik, D. (1948). *A concise history of mathematics*. Dover.
- Su, J. H., & Ying, J. M. (2014). Enhancing in-service mathematics teachers' professional knowledge with an HPM approach as observed in teachers' reflections. *Taiwan Journal of Mathematics Education*, 1(1), 79–97. <https://doi.org/10.6278/tjme.20140307.003>
- Suppes, P. (1975). From behaviorism to neobehaviorism. *Theory and Decision*, 6, 269–285.
- Suppes, P., & Macken, E. (1978). The historical path from research and development to operational use of CAI. *Educational Technology*, 18(4), 9–12.
- Suzuki, J. (2009). *Mathematics in historical context*. MAA. [https://books.google.es/books/about/Mathematics\\_in\\_Historical\\_Context.html?id=lew5IC5piCwC&redir\\_esc=y](https://books.google.es/books/about/Mathematics_in_Historical_Context.html?id=lew5IC5piCwC&redir_esc=y)
- Swanson, D., & Appelbaum, P. (2012). Refusal as a democratic catalyst for mathematics education development. *Pythagoras*, 33(2), 1–6. <http://www.pythagoras.org.za/index.php/pythagoras/article/view/189>
- Swetz, F. J. (1987). *Capitalism and arithmetic: The “new math” of the 15<sup>th</sup> century including the full translation of the Treviso arithmetic of 1478*, translated by David Eugene Smith. Open Court.
- Swetz, F. J. (1994). *From five fingers to infinity*. Open Court.
- Swetz F. J. (2013). Mathematical treasure: Ptolemy's almagest. *Convergence*. <https://www.maa.org/press/periodicals/convergence/mathematical-treasureptolemy-s-almagest>. Accessed 4 Jan 2022.
- Sztajn, P., Borko, H., & Smith, T. (2017). Research on mathematics professional development. In J. Cai (Ed.), *Compendium for research in mathematics education* (pp. 793–823). NCTM.
- Tabach, M., Levenson, E., Barkai, R., Tsamir, P., Tirosh, D., & Dreyfus, T. (2012). An organizer of mathematical statements for teachers: The six-cell matrix. *International Journal of Mathematical Education in Science and Technology*, 43(6), 765–777.
- Taeli, F. (2010). The new paradigm of complexity and education: an historical glance. *Polis Revista Latinoamericana.*, 25, 2–13. <http://polis.revues.org/400>
- Takahashi, A. (2021). *Teaching mathematics through problem solving: A pedagogical approach from Japan*. Routledge.
- Taras, M. (2005). Assessment–summative and formative—some theoretical reflections. *British Journal of Educational Studies*, 53(4), 466–478.
- Tartaglia, N (1500–1557). <https://mathshistory.st-andrews.ac.uk/Biographies/Tartaglia/>
- Tatnal, A., Davey, B. (2004). Streams in the history of computer education in Australia. In *IFIP international conference on the history of computing* (pp. 83–90). Springer.
- Tekin-Sitrava, R., Kaiser, G., & Işıksal-Bostan, M. (2021). Development of prospective teachers' noticing skills within initial teacher education. *International Journal of Science and Mathematics Education*, 20, 1611–1634. <https://doi.org/10.1007/s10763-021-10211-z>
- Thaqi, X., & Gimenez, J. (2012). *Prospective teacher's understanding of geometric transformation, presented in 12th international congress on mathematical education, Seoul*.
- Thomaidis, Y., & Tzanakis, C. (2007). The notion of historical 'parallelism' revisited: Historical evolution and students' conceptions of the order relation on the number line. *Educational Studies in Mathematics*, 66, 165–183. Special issue on the history of mathematics in mathematics education.
- Thomas, D., & Seely Brown, J. (2011). *A new culture of learning: Cultivating the imagination for a world of constant change*. CreateSpace Independent Publishing Platform.
- Thompson, P. (2002). Some remarks on conventions and representations. In F. Hitt (Ed.), *Mathematics visualisation and representations* (pp. 199–206). Psychology of Mathematics Education North American Chapter and Cinvestav-IPN.
- Tiede, J., & Grafe, S. (2018). *Triseum game-based learning validation study evaluation report – 2018*. European Schoolnet. [https://storage.eun.org/resources/upload/226/Triseum\\_Pilot\\_report-1.pdf](https://storage.eun.org/resources/upload/226/Triseum_Pilot_report-1.pdf)

- Tinio, V. L. (2003). *ICT in Education*. Retrieved from [https://e-learning.tsu.ge/pluginfile.php/183/mod\\_resource/content/0/ict\\_docs/ICT\\_in\\_education.pdf](https://e-learning.tsu.ge/pluginfile.php/183/mod_resource/content/0/ict_docs/ICT_in_education.pdf)
- Tolra, J. B. (1619). *Arismetica de Ivan Ventallol*. Gabriel Roberto.
- Tosca, T. V. (1709). Compendio mathematico. In *Tomo II* (1st ed.). Antonio Bordazar.
- TRC (Truth and Reconciliation Commission). (2015–2022). *Reports of the Canadian Truth and Reconciliation Commission*. Retrieved May 2022 from <https://nctr.ca/records/reports/>
- Treffers, A. (1987). Three dimensions: A model of goal and theory description in mathematics instruction. In *The Wiskobas project*. Reidel.
- Tress, B., Tress, G., & Fry, G. (2005). Defining concepts and the process of knowledge production in integrative research. In B. Tress, G. Tress, G. Fry, & P. Opdam (Eds.), *From landscape research to landscape planning: Aspects of integration, education, and application* (pp. 13–26). Springer.
- Trouche, L. (2004). Managing the complexity of human/machine interactions in computerized learning environments: Guiding students' command process through instrumental orchestrations. *International Journal of Computers for Mathematical Learning*, 9(3), 281–307.
- Trouche, L. (2005). Calculators in mathematics education: A rapid evolution of tools, with differential effects. In *The didactical challenge of symbolic calculators* (pp. 9–39). Springer.
- Trouche, L. (2021). Covid-19: les défis en termes de ressources et collaboration des enseignants. *Le Bulletin de l'APMEP, No. 539*, 3–10.
- Tyncherov, K. T., Olenev, A. A., Selivanova, M. V., & Kirichek, K. A. (2020, November). Modeling set theory laws using MAPLE computer algebra system. In *Journal of Physics: Conference Series (1661)*, 1, p. 012086. IOP Publishing.
- Tzanakis, C., & Arcavi, A. (2000). Integrating history of mathematics in the classroom: An analytic survey. In J. Fauvel & J. Maanen (Eds.), *History in mathematics education: The ICMI study* (pp. 201–240). Kluwer Academic Publishers.
- Tzanakis, C., Arcavi, A., Correia de Sa, C., Isoda, M., Lit, C.-K., Niss, M., Pitombeira de Carvalho, J., Rodriguez, M., & Siu, M.-K. (2000). Integrating history of mathematics in the classroom: An analytic survey. In J. Fauvel & J. van Maanen (Eds.), *History in mathematics education: The ICMI study* (pp. 201–240). Kluwer.
- Tzanakis, C., et al. (2002a). Integrating history of mathematics in the classroom: an analytic survey. In J. Fauvel & J. Van Maanen (Eds.), *History in mathematics education* (New ICMI Study Series, Vol. 6. Chap. 7). Springer.
- Tzanakis, C., Arcavi, A., Sa, C. C. D., Isoda, M., Lit, C. K., Niss, M., de Carvalho, J. P., Rodriguez, M., & Siu, M. K. (2002b). Integrating history of mathematics in the classroom: An analytic survey. In *History in mathematics education* (pp. 201–240). Springer.
- UNESCO. (2005). *Guidelines for inclusion: Ensuring access to education for all*. UNESCO.
- UNESCO. (2015). *The challenge of teacher shortage and quality: Have we succeeded in getting enough quality teachers into classrooms?* (Education for All Global Monitoring Report) (pp. 1–10). UNESCO Publishing. <http://hdl.voced.edu.au/10707/19155>
- UNESCO. (2020). *Policy brief: Education during COVID-19 and beyond*. United Nations. [https://www.un.org/development/desa/dspd/wp-content/uploads/sites/22/2020/08/sg\\_policy\\_brief\\_covid-19\\_and\\_education\\_august\\_2020.pdf](https://www.un.org/development/desa/dspd/wp-content/uploads/sites/22/2020/08/sg_policy_brief_covid-19_and_education_august_2020.pdf)
- UNICEF. (2007). Promoting the rights of children with disabilities. *Innocenti Digest*, 13, 1–68.
- Universal Declaration of Human Rights. (1948). <https://www.un.org/en/about-us/universal-declaration-of-human-rights>, <https://www.un.org/sites/un2.un.org/files/udhr.pdf>
- Uy, F. L. (2000). *Teaching mathematics concepts using a multicultural approach*. California State University. [https://learning.educatetogether.ie/pluginfile.php/12854/mod\\_resource/content/1/Teaching%20Mathematics%20Concepts%20with%20a%20Multicultural%20Approach.pdf](https://learning.educatetogether.ie/pluginfile.php/12854/mod_resource/content/1/Teaching%20Mathematics%20Concepts%20with%20a%20Multicultural%20Approach.pdf)
- Vale, I., Barbosa, A., & Pimentel, T. (2015). Math trails a rich context for problem-posing: An experience with preservice teachers. *Quaderni di Ricerca in Didattica (Mathematics)*, 25(2), 205–211.

- Valente, J. A. (1983). *Creating a computer-based learning environment for physically Handicapped children*. Dissertation, Doctor in Bioengineering and Education. Massachusetts Institute of Technology.
- Valente, J. A. (1996). (*Org.*) *O professor no ambiente Logo: Formação e atuação*. UNICAMP/NIED.
- Valente, J. A. (2002). A espiral da aprendizagem e as tecnologias da informação e comunicação: repensando conceitos. In M. C. R. A. Joly (Ed.), *A tecnologia no ensino: implicações para a aprendizagem* (pp. 15–37). Casa do Psicólogo.
- Valente, J. A. (2005). *A espiral da espiral de aprendizagem: o processo de compreensão do papel das tecnologias de informação e comunicação na educação*. Dissertation, Full Professor. Universidade Estadual de Campinas – UNICAMP.
- Valente, J. A. (2016). Integração do pensamento computacional no currículo da educação básica: diferentes estratégias usadas e questões de formação de professores e avaliação do aluno. *Revista eCurriculum*, 14(3), 864–897.
- Valente, J. A. (2019). Pensamento computacional, letramento computacional ou competência digital? Novos desafios da educação. *Revista Educação e Cultura Contemporânea*, 16(43), 147–168.
- Valente, J. A., & Almeida, M. E. B. (2020). Brazilian technology policies in education: History and lessons learned. *Arquivos Analíticos de Políticas Educativas*, 28(94). <https://doi.org/10.14507/epaa.28.4295>
- Valero, P. (2004). Socio-political perspectives on mathematics education. En P. Valero, & R. Zevenbergen (Edits.) *Researching the socio-political dimensions of mathematics education: Issues of power in theory and methodology*. Kluwer Academic Publishers.
- Valero, P. (2006). *Consideraciones sobre el contexto y la educación matemática para la democracia*. Foro Educativo Nacional. Año de Competencias Matemáticas.
- Valero, P., & Stenoft, D. (2010). The ‘post’ move of critical mathematics education. In *Cmathematics education: Past, present and future* (pp. 183–195). Brill Sense.
- Vallhonesta, F. R., Massa Esteve, M. R., Guevara Casanova, I., Puig-Pla, C., & Roca-Rosell, A. (2015). P, teacher training in the history of mathematics. In É. Barbin, U. T. Jankvist, & T. Kjeldsen (Eds.), *Proceedings of ESU7 history and epistemology in mathematics education* (pp. 113–128). Danish School of Education.
- van den Bogaart-Agterbeerg, D. A., Oostdam, R. J., & Janssen, F. J. J. M. (2021). From speck to story: Relating history of mathematics to the cognitive demand level of tasks. *Educational Studies in Mathematics*, 110, 49–64. <https://doi.org/10.1007/s10649-021-10093-6>
- Van Loon, M., & Sarzano, M. (2016). Quelques problèmes de la conception duale de la norme de l’action et de l’assertion. *Ed. La Connaissance et ses raisons*. Chevalier, J.M, Gaultier, B. La Philosophie de la connaissance au Collège de France.
- Vanegas, Y. M., & Giménez, J. (2014). Noticing creativity issues when future teachers analyzing problem solving dialogues. In S. Carreira, K. Jones, & N. Amado (Eds.), *Problem@web international conference. Technology creativity and affect in mathematical problem solving* (pp. 242–253). Universidade do Algarve.
- Vanegas, Y., & Giménez, J. (2021). Prácticas matemáticas democráticas: Análisis de una experiencia escolar. *AIEM*, 19, 71–85. <https://doi.org/10.35763/aiem.v0i19.417>
- Vanegas, Y. M., Díez-Palomar, J., & Giménez, J. (2012). Spaces for the democratic participation in and out of the mathematics. In *Proceedings CIAEM 64*.
- Vanegas, Y. M., Díez-Palomar, J., Font, V., & Giménez, J. (2013). Considering extrinsic aspects in the analysis of mathematics teacher-training programs. In A. M. Lindmeier & A. Heinze (Eds.), *Proceedings of the 37th conference of the international group for the psychology of mathematics education* (Vol. 5, p. 188). PME.
- Vanegas, Y., Giménez, J., Font, V., & Díez-Palomar, J. (2014). Improving reflective analysis of a secondary school mathematics teachers program. In C. Nicol, S. Oesterle, P. Liljedahl, & D. Allan (Eds.), *Proceedings of the joint meeting of PME 38 and PME-NA 36* (Vol. 5, pp. 321–328). PME.

- Vanegas, Y., Giménez, J., & Díez-Palomar, J. (2015a). Sociocultural contexts as difficult resources to be incorporated by prospective mathematics teachers. *Quaderni di Ricerca in Didattica (Mathematics)*, 25(2), 305–310.
- Vanegas, Y., Giménez, J., & Font, V. (2015b). Aprender a formar en ciudadanía en la formación de profesores de matemáticas. *ALME*, 28, 1360–1368.
- Vanegas, Y., Font, V., & Giménez, J. (2017a). How future teachers improve epistemic quality of their own mathematical practices. In *Proceedings of the 9th congress of the European Society for Research in mathematics education*.
- Vanegas, Y., Giménez, J., & Font, V. (2017b). Conexiones matemáticas en la reflexión sobre prácticas escolares. In L. A. Serna (Ed.), *Acta Latinoamericana de Matemática Educativa* (pp. 1114–1124). Comité Latinoamericano de Matemática Educativa.
- Vanegas, Y., Díez-Palomar, J., Giménez, J., & Font, V. (2018). *Using deliberative dialogue to analyze critically the role of families within a master program for future teachers of mathematics*. [https://hal.archives-ouvertes.fr/ETC3/public/Full\\_Download.pdf#page=62](https://hal.archives-ouvertes.fr/ETC3/public/Full_Download.pdf#page=62)
- Vanegas, Y., D'Ambrosio, U., & Giménez, J. (2019a). Discurso y prácticas democráticas en la clase de matemáticas. *Redimat*, 8(2), 139–165. <https://doi.org/10.17583/redimat.2019.3112>
- Vanegas, Y., Prat, M., & Rubio, A. (2019b). Characterization of the learning trajectory of children aged six to eight years old when acquiring the notion of length measurement. In U. T. Jankvist, M. van den Heuvel-Panhuizen, & M. Veldhuis (Eds.), *Proceedings of the eleventh congress of the European Society for Research in mathematics education* (pp. 2381–2388). Freudenthal Group & Freudenthal Institute/Utrecht University and ERME.
- Vanegas, Y., Prat, M., Giménez, J., & Edó, M. (2021). Tareas profesionales en la formación de maestros de educación infantil. *Acta scientiae*, 23(3), 30–51. <https://doi.org/10.17648/acta.scientiae.6205>
- Vasco, C. (2002). Siete tensiones irresolubles en la articulación de la historia de las matemáticas con la enseñanza de las matemáticas. *Conferencia inaugural de la Primera Escuela Latinoamericana de Historia y Epistemología de las Matemáticas*. Universidad del Valle.
- Vasco, D., & Climent, N. (2018). El estudio del conocimiento especializado de dos profesores de Álgebra Lineal. *PNA. Revista de Investigación en Didáctica de la Matemática*, 12(3), 129–146. <https://doi.org/10.30827/pna.v12i3.6454>
- Vecchia, R. D., Maltempo, M. V., & Borba, M. C. (2015). The construction of electronic games as an environment for mathematics education. In Lowrie, T. & Jorgensen (ZEVENBERGEN), R. (Eds.), *Mathematics education in the digital era* (pp. 55–70). Springer.
- Velasco, S., & Jablonska, A. C. (2010). *Construcción de políticas educativas interculturales en México: debates, tendencias, problemas, desafíos*. En *Horizontes Educativos*. Universidad Pedagógica Nacional.
- Venkat, H., & Adler, J. (2020). Pedagogical content knowledge within “mathematical knowledge for teaching”. In S. Lerman (Ed.), *Encyclopedia of mathematics education* (pp. 655–658). Springer.
- Verdejo, F. (1794). *Compendio de matemáticas puras y mixtas para instrucción de la juventud* (1st ed.). Viuda de Ibarra.
- Vergnaud, G., & Récopé, M. (2000). De Revault d'Allonnes à une théorie du schème aujourd'hui. *Psychologie Française*, 45(1), 35–50.
- Vieira, E. R. (2013). *Grupo de Estudos de professores e a apropriação de tecnologia digital no ensino de geometria: caminhos para o conhecimento profissional*. Tese (Educação Matemática). Universidade Bandeirante de São Paulo.
- Vieira, E. R., & Lobo da Costa, N. M. (2016). O processo de apropriação de tecnologias digitais por professores dos anos iniciais para o ensino de Geometria. *Perspectivas da Educação Matemática*, 9, 765–785.
- Vithal, R., & Skovsmose, O. (1997). The end of innocence: A critique of ‘ethnomathematics’. *Educational Studies in Mathematics*, 34(2), 131–157.



- Voloshinov, V. N. (1973). *Marxism and the philosophy of language*. (L. Matejka, I. R. Titunik, Trans.). Harvard University Press.
- Voogt, J., & Roblin, N. P. (2012). A comparative analysis of international frameworks for 21st century competences: Implications for national curriculum policies. *Journal of Curriculum Studies*, 44(3), 299–321.
- Vygotsky, L. (1932/1962). *Thought and language*. MIT Press.
- Waema, M. T. (2005). A brief history of the development of an ICT policy in Kenya. *At the Crossroads: ICT policy making in East Africa*, 25–43.
- Walkerdine, V. (1988). *The mastery of reason: Cognitive development and the production of rationality*. Routledge.
- Wang, K., Wang, X., Li, Y., & Rugh, M. (2018). A framework for integrating the history of mathematics into teaching in Shanghai. *Educational Studies in Mathematics*, 98, 135–155.
- Warnke, G. (1991). *Herméneutique, tradition et raison* (J. Colson, Trans.). De Boeck.
- Weber, K., & Leikin, R. (2016). Recent advances in research on problem solving and problem posing. In A. Gutiérrez, G. Leder, & P. Boero (Eds.), *The second handbook of research on the psychology of mathematics education* (pp. 353–382). Springer.
- Weigend, M. (2020). Programming languages for secondary schools, python. In A. Tatnall (Ed.), *Encyclopedia of education and information technologies* (pp. 1370–1378). Springer.
- Wells, D. (1992). *The penguin book of curious and interesting puzzles*. Penguin Books.
- White, L. (1947/1956). The locus of mathematical reality: An anthropological footnote (1947). In J. Newman (Ed.), *The world of mathematics: A small library of the literature of mathematics from A'h Mose the scribe to Albert Einstein* (Vol. 4, pp. 2348–2364). Simon and Schuster.
- White, A. (1993). *Essays in humanistic mathematics*. The Mathematical Association of America (MAA Notes no. 32).
- Whitin, D., & Wilde, S. (1995). *It's the story that counts: More children's books for mathematical learning, K-6*. Heinemann.
- Wilder, R. (1950). The cultural basis of mathematics. Plenary address to the international congress of mathematicians, Cambridge, MA, USA, 30 August to 6 September. In *Proceedings of the international congress of mathematicians* (Vol. 1, pp. 258–271) [https://mathshistory.st-andrews.ac.uk/Extras/Cultural\\_Basis\\_I/](https://mathshistory.st-andrews.ac.uk/Extras/Cultural_Basis_I/)
- Wilder, R. L. (1981). *Mathematics as a cultural system*. Pergamon Press.
- Wiles, A. (1995). Modular elliptic curves and Fermat's last theorem. *Annals of Mathematics*, 443, 55.
- Wing, J. M. (2006). Computational thinking. *Communications of the ACM*, 49(3), 33–35.
- Zamorano, A. (2015). *La práctica de la enseñanza de las matemáticas a través de las situaciones de contingencia*. Unpublished Doctoral dissertation, Universitat Autònoma de Barcelona.
- Zang, P. (2021). Opportunities to learn three-dimensional shapes in primary mathematics: The case of content analysis of primary mathematics textbooks in Hong Kong. *EURASIA Journal of Mathematics, Science and Technology Education*, 17(6), em1971. <https://doi.org/10.29333/ejmste/10884>
- Zapatera, A., Callejo, M. L., & Badillo, E. (2017). Evolución de la mirada profesional: cambios en el discurso de estudiantes para maestro. In J. M. Muñoz-Escolano et al. (Eds.), *Investigación en Educación Matemática XXI* (pp. 477–486). SEIEM.
- Zaragoza, J. (1669). *Arithmetica universal que comprehendere el arte menor, y maior, algebra vulgar, y especiosa*. Geronimo Vilagrassa.
- Zaslavsky, C. (1993). *Multicultural mathematics: Interdisciplinary cooperative-learning activities*. J. Weston Walch.
- Zaslavsky, C. (1996a). *Multicultural Math Classroom, Bringing in the World*. Heinemann. <https://eric.ed.gov/?id=ED393667>
- Zaslavsky, C. (1996b). *The multicultural math classroom: Bringing in the world*. Heinemann.
- Zaslavsky, C. (1998). *Math games and activities from around the world*. Chicago Review Press.

- Zehetmeier, S., & Krainer, K. (2011). Ways of promoting the sustainability of mathematics teachers' professional development. *ZDM-Mathematics Education*, 43(6), 875–887. <https://doi.org/10.1007/s11858-011-0358-x>
- Zhang, Y., & Liu, B. (2021). Psychological distress among chinese college students during the COVID-19 pandemic: Does attitude toward online courses matter? *Frontiers in Psychology*. Published online 2021 May 28. <https://doi.org/10.3389/fpsyg.2021.665525>
- Zorbala, K., & Tzanakis, C. (2004). The concept of the plane in geometry: Elements of the historical evolution inherent in modern views. *Mediterranean Journal of Research in Mathematics Education*, 3(1–2), 37–62. Special double issue on the role of the history of mathematics in mathematics education (proceedings from TSG 17 at ICME10).
- Zuberek, M. (2007). Multidisciplinarity – the grand challenge and the future of academia. In E. Kovács, P. Olajos, & T. Tórnács (Eds.), *Proceedings of the 7th international conference on applied informatics* (Vol. 2, pp. 81–91). Eszterházy Károly College.

# Index

## A

Adult education, 201, 274, 275  
Affective domains, 40, 282  
African Diaspora, 200  
Afro-Colombian Studies, 138–142  
Ahmes Papyrus, 12, 59  
Akizuki, Y., 194  
Alexandria, 23, 72, 118  
Algebra, xv, 36, 58, 60, 68, 73, 80, 82–85,  
87–91, 93–95, 97, 98, 109, 126, 157,  
161, 192, 212, 239, 241, 301, 315, 320,  
324, 336, 366, 367, 371, 376, 390, 392  
Algorithms, xvi, 37, 38, 41, 64, 69, 71, 153,  
157, 159, 162, 164, 197, 201, 210, 226,  
228, 239, 240, 243, 258, 281, 298, 368,  
370, 371  
Al-Khwārizmī, 82, 109  
American Mathematical Society (AMS), 104,  
192  
Analytic geometry, 80  
Andalusian Regional Strategy for Cohesion and  
Social Inclusion, *see* ERACIS  
Angola, 140  
Anthropology, 118, 191, 202  
Antiracist mathematics, 199  
Archimedes, 24, 173, 174, 176, 177, 179, 181,  
192, 212, 239  
Assessment, 104, 129, 151, 155, 164, 165, 245,  
257, 275, 281, 287, 288, 304, 340,  
342–344, 403  
Astronomy, 82, 118, 239, 325  
Axiomatic approach, 2

## B

Babylonians, xii, 59, 72, 81, 82, 109, 111, 151,  
155–161, 164, 213, 215, 237–243, 247,  
249, 268  
*Bamana*, 201  
Bede the Venerable, 119  
Berlin Papyrus, 81  
Besalú, X., 135  
*Bildung*, 120  
*Bildung Rose*, 120, 121  
Binomial, teaching/learning of, 54, 109, 111,  
112, 137  
Bishop, A., 302, 402  
Brazilian Landless Movement, 201  
Brilliance, of learners, 248  
Brousseau, G., 2, 6, 279, 287

## C

Calculation, 11, 24–26, 45, 58, 72, 104, 140,  
159, 197, 227–229, 238, 240, 258,  
298–302, 304, 312, 315, 324, 335, 388  
Calculators, 28, 228, 243, 298, 299, 302, 310,  
315, 318, 321, 336  
Cardano, G., 192  
Case studies, 12, 55, 123, 211, 284  
Castelnuovo, E., xii, 1  
Chair of Afro-Colombian Studies (CEA),  
138–142  
C.I.E.A.E.M (The International Commission  
for the Study of Mathematics  
Education), 1, 12

- Civilized, 193  
 Clairaut, A.C., 119  
 Colonialism, 195, 196, 204, 246, 402  
 Coloniality, 195–199, 204, 402  
 Competencies, 104, 117, 119, 140, 264, 275, 278, 285, 370  
 Complexity, 53, 128, 129, 131, 168, 169, 171, 198, 202, 226, 285, 286, 326, 335, 383  
 Complexity theory, 129  
 Computer algebra system (CAS), 301, 302, 312, 313, 315  
 Computers, 127, 128, 298–300, 310–312, 314, 315, 318, 321, 325, 334–336, 339, 343, 362–364, 366–372, 383, 384  
 Conjectures, xiv, 12, 20, 52, 53, 55, 56, 61, 63–66, 250, 256, 260, 314, 324, 337, 339, 341, 346, 367, 387, 392, 393, 395  
 Creativity, 45, 50, 109, 112, 135, 200, 250, 287, 371, 375, 385  
 Critical mathematics education, 200  
 Cultural diversity, 106, 108, 110, 113, 127, 132, 136  
 Culturally relevant pedagogy, 199  
 Culturally responsive pedagogy, 199  
 Cultural perspective, 11, 31, 192  
 Cultural understanding, 5, 28  
 Culture, xii–xv, xvii, 2, 5, 10, 12, 18, 19, 22, 23, 27–30, 36, 38, 51, 52, 54, 58, 71–74, 81, 106–108, 110–112, 117–142, 150, 151, 153–155, 164, 165, 171, 183, 184, 190–201, 203, 204, 220, 229, 231, 234, 235, 237, 238, 240, 241, 244, 245, 247–252, 257, 258, 263, 268, 274, 283, 302, 335, 339, 350–352, 354, 370, 375, 401, 402  
 Curriculum  
 guidelines, 36, 370
- D**  
 D'Ambrosio, U., 34, 106, 108, 154, 164, 191, 195, 196, 198, 274, 287, 303, 362, 369  
 Democratic mathematics, 131  
 Democratization, 123, 275  
*Dépaysement*, 11, 20  
 Descartes, R., 98, 181, 192, 194, 298  
 Device, 243, 287, 302, 303, 310, 313, 315, 335, 340, 354, 366, 376, 382, 384, 386–392, 395–397, 403  
 Didactics of Mathematics, 11, 46, 125, 150, 169, 183, 310  
 Digital Geometry Software (DGS), 301, 302, 312, 315, 337  
 Digital learning, 278
- Diophantine equation, 52, 58, 67, 69, 71, 72, 74, 82, 239  
 Diophantus, 71, 72, 80, 82, 181  
 Dissemination  
 of mathematical knowledge via historical studies, 402  
 of research on the roles of the history of mathematics in mathematics education, 402  
 Diversity, xvi, 54, 55, 106–108, 110–113, 118, 127, 132, 135, 142, 168, 169, 173, 180–184, 190, 203, 236, 247, 250, 286, 312, 313, 368  
 Dynamic process, 124
- E**  
 Education and Social Environment Project, 127  
 Eglash, R., xii, 200, 201  
 Egypt, Ancient, 37, 38, 164, 193, 213  
 Eighteenth century, xiii, 12, 83, 84, 90–96, 119, 228  
 Emotional dimensions, 169, 183, 286  
 Epistemology, 18, 29, 103, 111, 125, 142, 183, 197, 274, 276, 277, 314, 316, 339, 340  
 ERACIS project (*Estrategia Regional Andaluza para la Cohesión y la Inclusión Social*), 52, 59, 60, 63, 74  
 Eswatini (Swaziland), 139  
 Ethnomathematics  
 critical, 198, 199, 203  
 Ethnomodelling, 202  
 Euclid  
*Elements*, 7, 9, 24  
 Euclidean theorems, 24  
 Euclid-Euler Theorem, 7  
 Euler, L., 7–9, 12, 63–66, 83, 171, 173, 178, 179, 181, 387  
 Eurocentric discourses, 201  
 Evolution, xv, xvi, xvii, 4–6, 10–12, 34, 36, 43–45, 52, 54, 55, 57, 80, 83, 96, 98, 103–105, 150, 154, 176, 200, 211, 259, 273, 288, 298, 302–304, 311, 312, 318, 319, 323, 324, 326, 340, 350, 356, 362, 366, 369, 376, 381, 387, 401, 403  
 Experimentation, 50, 122, 286, 324, 325  
 Exploratory research, 84
- F**  
 Factors, 5, 6, 61, 62, 93, 107, 134, 137, 169, 190, 198, 258, 277, 311, 345, 369, 389  
 Fanon, F., 195  
 Fasheh, M., 199, 200

- Fermat, P. de, 8, 56, 65, 181, 238  
 Fermat's Last Theorem, 56, 238  
 Fettweis, E., 191  
 Fontana, *see* Tartaglia, N.F.  
 Fractals, xii, 57, 201, 402  
 Freire, P., 50, 138, 287, 303, 364  
 Freudenthal, H., 1, 2, 23, 50, 109, 150, 209–211, 213–215, 285, 312, 320, 322, 326  
 Freud, S., 131  
 Freyle, J.D., 190  
 Funds of knowledge, 197
- G**
- Gender, 85, 140, 155, 158, 159, 165, 171, 181, 236, 246, 247, 283  
 GeoGebra, 57, 301, 312, 313, 321, 324, 325, 336, 347, 348, 355, 366, 375, 376, 382, 384–386, 388, 390–392, 397  
 Geometry, xiv, xv, 8, 36, 42, 58, 80, 98, 118, 119, 126, 140, 157, 161, 169, 173, 191, 192, 239, 241, 259, 261, 262, 265, 266, 268, 280, 298, 300–303, 315, 321, 335–337, 364–367, 375, 376, 381–397  
 Gerdes, P., 140, 191, 196, 197  
 Goldbach, C., 63–66  
 Goldbach's conjecture, 12, 56, 63–65  
 Gravemeijer, K., 6, 320  
 Greco-Roman Era, 23, 30  
 Greece, Ancient, 37–39, 161  
 Guzmán, M. de, xiii, 51, 104, 122, 125, 127
- H**
- Hegemony, 103  
 Heptalogue, the, 133, 142  
 Heritage (Cultural Legacies), xvi, 2, 3, 132, 134, 213, 237, 244–246, 248, 249, 259, 263  
 Hermeneutic circle, 21  
 Higher education, 37, 103, 120, 274, 302, 364, 375  
 Hipparchus of Bithynia, 23  
 Historical documents, 247, 252  
 Historical–epistemological approach, 169  
 Historical trajectories, 110  
 Hohenwarter, J., 366  
 Hohenwarter, M., 312  
 Homogenization of mathematics, 196  
 Horizontal content knowledge (HCK), 3–5, 10, 12, 257, 276
- Horizontal mathematics, 51  
 Humanization of mathematics  
   humanizing mathematics, xi  
 Humboldt, W. von, 120  
 Hypatia, 161, 181  
*Hyper Articles en Ligne* (HAL), 127  
 Hypotheses, 55, 56, 65, 91, 103, 104, 260, 350, 351, 403
- I**
- Imperialism, 195, 196, 402  
 Inaugural understandings, 11, 22, 23, 26–30  
 India, xiv, 59, 82, 223, 234, 239, 248, 251  
 Indigenous  
   mathematics, 121, 127, 135, 194–196, 201, 204, 233, 236, 238, 246, 250, 252  
   peoples, 136, 142, 190, 191, 195, 204, 234, 236  
   schools, 136, 142, 194–196, 204, 234, 236  
 Induction, 80, 104  
 Infinitesimal calculus, 80  
 Inquiry, 53, 60, 110, 154, 236, 250, 259, 278, 285, 288, 326, 339, 340, 345  
 In-service teacher education, 19, 30  
 Instrumentalization, 310, 318, 319, 323, 336  
 Instrumentation, 310, 318, 319, 323, 324, 336, 341, 342, 352  
 Integration, 110, 126, 150–152, 154, 183, 190, 250, 310, 312, 317, 335, 345, 355, 356, 362–376, 389, 403  
 Interaction, 45, 55, 107, 111, 118, 132, 134, 137, 169, 172, 183, 190, 191, 202, 203, 259, 278–281, 285, 287, 304, 315, 351, 356, 362, 363, 366–369, 385, 387, 389, 390, 392, 395, 396  
 Intercultural education (IE), 132, 133, 135  
 Interculturalism, 131  
 Interculturality, 118, 131–135, 142, 286  
 Intercultural mathematics education, 133  
 Interdisciplinarity, 284, 317, 321  
 Interdisciplinary approach, 110, 112, 170, 403  
 International Commission on Mathematical Instruction (ICMI), 18, 105, 125, 274, 277, 279, 310, 325  
 Interpretive methodology, 11  
 Islam, 213, 237, 238
- J**
- Jaramillo, D., 107, 108, 136, 139  
 Joseph, G., 199

**K**

Keitel, C., xii, 51, 120, 122  
 Khaldum, I., 190  
 Kindergarten education, 34, 36, 260  
 Klotz, E., 301  
 Knijnik, G., 108, 197, 201  
 Königsberg bridge problem, 171, 178  
 Kuhn, T., 128  
 Kumashiro, K., 198

**L**

Laborde, J.-M., 300, 301, 364, 387  
 Legitimacy, 103  
*Litema*, 140, 142  
 Logic  
   dream of unification with, 194  
 Lorde, A., 199  
 Luquet, G.-H., 191  
*Lusona*, 140

**M**

Manipulation, algebraic, 336  
 Marginalization, 135  
 Mathematical analysis, 54, 104  
 Mathematical modelling, 51, 52, 55, 57, 73, 74,  
   108, 312, 326  
 Mathematical practices, 29, 123, 190, 194, 201,  
   202, 235, 280, 281, 286  
 Mathematics and living together, 113  
 Mathematization, 50, 51, 53, 55, 73, 74, 283,  
   285, 320, 322  
 Mathematized society, 118  
   *See also* Demathematization;  
   Mathematization  
 Measurement, xiv, 24, 36, 66, 136, 140, 213,  
   214, 227, 259, 263–265, 278, 383, 384,  
   386, 388, 395  
 Medieval era, 80  
 Memes, 304, 350–355  
 Mersenne Primes, 7  
 Mesopotamia, xiv, 193, 239  
 Mesopotamia, Ancient, 36  
 Meta-tasks, 155, 164  
 Methodologies, 5, 11, 39–40, 50, 60, 73, 84–85,  
   108, 135, 153, 196, 274, 277, 279, 288,  
   363, 375  
 Modeling/modelling, 12, 51–54, 57, 71, 73, 74,  
   108, 202, 260, 283, 304, 311–313, 316,  
   317, 320–323, 325, 326, 371  
*Mujaawarah*, 199  
 Multiculturalism, 107, 131, 132, 204

Multicultural Mathematics Education, 134  
 Multicultural perspective, 123, 134  
*Muthanna*, 200

**N**

Namibia, 140  
 Naresh, N., 200  
 National Council of Teachers of Mathematics  
   (NCTM), 127, 150, 220, 222, 231, 260,  
   312, 316  
 Non-Western mathematics, 184, 204  
 Numbers  
   number theory, 71, 73, 80, 169, 241

**O**

Object  
   of digital learning environment, 363  
   of study, 279  
 Operations, 36, 42, 46, 60, 72, 92, 153, 159,  
   162, 201, 220–222, 227, 281, 285, 298,  
   316, 345, 351, 372, 388  
 Orey, D., 190, 197, 202

**P**

Papert, S., 300, 303, 362  
 Pappus, 118  
 Papyrus of Rhind, 227, 231  
 Pedagogical renewal, 126  
 Pedagogical Renewal Movements (PRM), 126  
 Pedagogy, 18, 50, 111, 112, 126, 127, 138, 184,  
   199, 235, 237, 246, 257, 287, 335, 337,  
   356, 367, 373–375, 383, 402, 403  
 Perfect numbers, 7–9  
 Peruvian Association for Research in  
   Mathematical Education, 136  
 Philosophy of mathematics, 36, 46, 235  
 Plato, 118, 173, 174, 176, 177, 179, 181, 223,  
   238, 241  
 Politological doctrines, 107  
 Polya, G., xi, 54, 219, 221, 263  
 Popularization, 125  
 Post-colonialism, 195–198  
 Post-humanism, 198  
 Power, fantasy, 194  
 Pre-school, 112, 172, 173, 183  
 Pre-school education, 183  
 Pre-service, 19, 30, 112, 168, 170, 209, 213,  
   234, 235, 251, 275, 277–278, 284, 287  
 Pre-service teacher education, 168, 233–252,  
   269

Presmeg, N., 198  
 Primary education, 127, 154, 161, 164, 213, 256–269, 277  
 Primary school teachers (PSTs), 34, 36, 110, 112, 168–173, 176, 178, 183, 184  
 Principles, 50, 71, 73, 104, 109, 119, 123, 125, 133, 162, 181, 191, 194, 256, 263, 275, 285, 286, 312, 315, 345, 367, 375  
 Probability, 58, 80, 104, 259  
 Problem solving, 11, 36, 45, 46, 50–53, 98, 122, 124, 142, 155, 213, 219–222, 231, 234, 235, 240, 249, 250, 256, 259, 263, 275, 304, 312, 320, 326, 334, 371, 403  
 Proclus, 118  
 The Program for International Student Assessment (PISA), 73  
 Programming, 300, 301, 314, 315, 334, 362–364, 367–369, 371–373, 375, 376  
 Proofs, xv, 2, 7, 12, 20, 52, 55, 56, 65, 72, 80, 89, 90, 169, 170, 234, 238, 241, 250, 257, 337, 350, 352  
 Psychogenetics, 2  
 Ptolemy, 21, 23–30, 118  
 Pythagoras, 139, 161, 174, 176, 177, 179, 181, 193, 238, 245, 298, 299

**Q**  
 Quadratic equations, 12, 80–85, 87–90, 92–98, 109, 151, 155–161, 164  
 Qualitative methodology, 11, 39

**R**  
 Raum, O.F., 194  
 Refutations, xv, 12, 52  
 Reorientation role, 4, 11, 12  
 Replacement role, 4  
 Representation, 9, 11, 34, 35, 37, 38, 40, 41, 43, 46, 64, 66, 72, 122, 127, 176, 197, 198, 202, 203, 212, 234–237, 240, 248, 251, 257, 258, 261, 262, 264, 278, 281, 283, 286, 298, 300, 301, 304, 310, 312, 313, 315, 316, 318, 319, 323–326, 336–338, 351, 352, 370, 374, 383, 387, 388  
 Research teams approach, 173  
 Resource, 383  
   *See also* Historical documents for learning  
 Rich, A., 302  
 Rome, Ancient, 139  
 Rosa, M., 83, 190, 197, 202

**S**  
 Said, E., 191, 196, 225  
 Salas, Á.P.V., 138  
 Salvador, F.V. do, 191  
 Sand divination, *see Bamana*  
 Schattschneider, D., 301, 382  
 Scheler, M., 118  
 Science, technology, engineering, arts, mathematics (STEAM), 199, 401, 403  
 Science, technology, engineering, mathematics (STEM), 199, 310, 312, 313, 316–317, 320, 321, 326, 372, 381  
 Scientific stance, 110, 172  
 Screen, 303, 310, 312, 315, 318, 362, 366, 368, 385, 386, 389–397  
   *See also* Analytic geometry; Calculators; Computers; Digital Geometry Software (DGS); Ethnomodelling; In-service teacher education; Pre-service teacher education; Software; Teacher education; Technology; Tools  
 Semiotic mediation, 318, 389, 393  
 Semiotic system, 323, 324  
 Seventeenth century, 12, 138  
*Sipatsi*, 140, 141  
 Sixteenth century, 12, 72, 223, 298  
 Smartphones, 366, 382, 389–391, 393–397  
 Sociocultural approaches, 29, 111, 190, 318, 319, 325, 326  
 Sociocultural perspective  
   Sociology of Mathematics, 46  
 Software, 299, 301–303, 311–313, 315, 321, 334, 336, 340, 344, 363–367, 372–375, 385, 389, 395  
 Sona drawing, *see Lusona*  
 South Africa, 140  
 Spengler, O., 191, 192  
 Splendor, *see* Brilliance, of learners  
 Stereotypes, 132, 199, 249  
 Stoutemyer, D., 302  
 Struik, D., 192  
 Systems thinking, 171

**T**  
 Talent, 57, 125  
 Tartaglia, N.F., 12, 67  
 Task resolution, 35, 37, 39, 41–43  
 Teacher education, 127, 130, 168, 231, 233–235, 246, 251, 256, 261, 273–288, 343, 344, 366, 370

- Technology, xiv, xvi, xvii, 6, 73, 111, 118, 119, 121, 124, 126–128, 130, 169, 231, 275, 280, 283, 285, 287, 288, 297–305, 310–313, 315–318, 321, 323–326, 334–356, 362–376, 381–397, 402, 403
- Theory of numbers, *see* Numbers, number theory
- Third International Mathematics & Science Study (TIMSS), 73
- Tonga, 140
- Tools, xiii, 3, 5, 6, 10, 23, 34, 50, 52, 72, 73, 97, 111, 112, 120, 122, 128, 138, 149, 151, 158, 161, 164, 169–172, 196, 199, 200, 204, 213, 259, 263, 274, 280, 286–288, 300, 302–304, 310–326, 335, 337, 339–341, 344, 346, 348, 352, 355, 366, 371, 383, 384, 386–388, 396–398, 401–403
- Topology, 80
- Touchscreens, 366–368, 376, 382, 385, 389–390, 395, 402, 403
- Trigonometry, 11, 21, 23, 24, 26–30, 80, 268, 365
- U**
- Undergraduate education, 40, 45
- United Nations Educational, Scientific and Cultural Organization (UNESCO), 125, 132, 168, 326
- Universal Declaration of Human Rights (UDHR), 132
- V**
- Vessels Problem, 12, 67
- W**
- White, L., 193
- Wilder, R., 192, 193
- Worksheets, 6, 151, 154, 155, 157, 158, 160, 164, 248, 249, 345, 348, 349