



# Design of Innovation and Entrepreneurship Effect Evaluation System for College Students Based on MOA Model

Dan Zhao<sup>1</sup>(✉) and Huan-wei Liang<sup>2</sup>

<sup>1</sup> Changchun Institute of Finance and Economics, Changchun 130000, China  
zhaodan45632@163.com

<sup>2</sup> Guangzhou Huali College, Guangzhou 511325, China

**Abstract.** With the change of social background, the environment of students' innovation and entrepreneurship is also changing. The traditional evaluation system can not meet the needs of higher vocational education. In order to better meet the current needs of higher education, improve the adaptability of College Students' innovation and entrepreneurship effect evaluation system, and achieve a good evaluation of students' Entrepreneurship effect, this paper designs the innovation and entrepreneurship effect evaluation system based on MOA model. In the hardware design, the CPU is determined according to the system functional requirements, and with the support of the CPU, the serial communication circuit is designed to realize the functions of data uploading and downloading. At this point, the system design is complete. The test results show that the designed evaluation system has high concurrency and anti-pressure ability, which shows that the system has good adaptability to heterogeneous data.

**Keywords:** MOA model · College students · Innovation and entrepreneurship · Effect evaluation

## 1 Introduction

Vocational education “take the service as the objective, take the employment as the guidance”, the innovation and entrepreneurship education is its connotation. As an important part of the vocational education system, higher education should constantly improve the quality of innovation and entrepreneurship education and do a good job in innovation and entrepreneurship education. To achieve this goal, we must speed up the construction of the evaluation system and mode of innovation and entrepreneurship education, speed up its popularization and application, find out the problems existing in innovation and entrepreneurship education in time, and take effective measures to solve them [1].

Early on, UNESCO (United Nations Educational, Scientific and Cultural Organization) proposed that “a degree is no longer equivalent to a job” and that graduates should no longer be confined to job seekers, but should also become successful entrepreneurs and job creators. Innovation and entrepreneurship education originated in the US, and the Babson College, which offers a bachelor’s degree in entrepreneurship education, gradually established a more comprehensive innovation and entrepreneurship education system [2]. The United Kingdom, Germany, Japan, Canada and other developed countries have also set off an upsurge of innovation and entrepreneurship education, taking the implementation of innovation and entrepreneurship education as a strategic plan to promote national economic and social development, and gradually forming an innovation and entrepreneurship curriculum system and teaching system with national characteristics and school characteristics. Although the innovation and entrepreneurship education in our country started late, it has become an important way to promote the innovation-driven development in our country and narrow the gap with the technological innovation and development in developed countries. Therefore, we must improve the quality of innovation and entrepreneurship in higher vocational colleges and build a corresponding evaluation system [3].

In addition, vocational education aims at service and employment-oriented. From this level, we can say that innovation and entrepreneurship education is the connotation of vocational education. However, the research and practice of vocational education evaluation in the past mostly focused on moral education evaluation, curriculum evaluation, skill evaluation, professional ability evaluation and so on. Therefore, it is necessary to design an innovation and entrepreneurship effect evaluation system for college students in order to provide a complete evaluation tool for the government and colleges themselves [4].

Although there are many mature research results in the design of college students’ innovation and entrepreneurship evaluation system, such as the integration of social support environment, school investment and student performance. In addition, there are some people from the process of action, environmental factors and reliability and validity of the balance of college students to achieve innovation and entrepreneurship evaluation. However, with the change of social background, the environment of college students’ innovation and entrepreneurship is also changing. The traditional evaluation system has been unable to meet the needs of higher vocational education. In order to better meet the current needs of higher education, improve the adaptability of the evaluation system of College Students’ innovation and entrepreneurship effect, and realize the good evaluation of students’ Entrepreneurship effect, this paper introduces the MOA model into this field, and designs the evaluation system of innovation and entrepreneurship effect based on the MOA (Motivation; Opportunity; Ability) model. In the hardware design, the CPU (Central Processing Unit) is determined according to the system functional requirements, and with the support of CPU, the system can realize the evaluation of students’ Entrepreneurship effect, The serial communication circuit is designed to realize the function of data upload and download. So far, the system design has been completed, which is expected to provide some help to solve the above problems.

## 2 Hardware Design of Innovation and Entrepreneurship Effect Evaluation System for College Students Based on MOA Model

### 2.1 Selection and Design of System CPU

The system CPU needs to provide support for the function realization of the whole system, the most important is to support the serial communication device data acquisition, and data stored in the storage module through the DEBUS bus. According to the work to be done by the CPU, consider the following aspects of CPU selection [5]:

In the system debugging stage, needs to have the input output design, in order to take the different debugging method and the observation debugging result, therefore the CPU must have the certain number I/O port. To simplify the hardware, the output module can be a serial LCD module. Up to four I/O ports are required here. In order to observe the debugging process, you also need to access three to four LED, in this part of the need for about four I/O port. The input part is controlled by keys. The keys do not need a matrix keyboard, only need to set 3 to 4 adjustment keys. Here also need 3 to 4 I/O ports. LCD module, debug button and LED in the final integration of the system, can also be used as a formal output display, functional indicators and function keys. So these ports are initially used for debugging, and later will become part of the system, can not be excluded, a total of at least 12 I/O port CPU. In addition, two I/O ports are required to acquire EEPROM data using the I2C bus. In addition, because of the need of “conflict detection”, the flag line of conflict detection needs to occupy 1 I/O port. Finally, it is best to reserve some I/O ports for future expansion of system functionality. So, at this point, I/O ports need to be at least 15 N each.

Considering the convenience of system debugging and maintenance, CPU should have the function of ISP online programming. Online programming capabilities are not always in use, so I/O ports used for online programming can be reused for other functions [6]. However, considering the stability of online programming and the inconvenience of reusing the software, 3 I/O ports are specially designed for online programming. At this point, the CPU's I/O port is at least 17 N.

Nowadays, the function of CPU is developing rapidly. In order to simplify the external devices, many CPUs integrate some common functions, such as A/D, D/A, voice, floating point, watchdog, etc. Since the design system does not require these functions, there is no need to choose a CPU with additional functions to increase costs, and the performance of the CPU can be seen from its own parameters, such as the capacity of the internal ROM and RAM, the number and bits of the internal timer, the number of internal interrupt sources, the size of the internal stack, the frequency at which the CPU runs, the data width of the CPU universal register, etc. The first metric to be considered here is the general register data width of the CPU. And if there is no complex and precise large-scale operation, the general 8-bit single-chip can meet the needs of field data acquisition [7].

According to the above considerations, the AT89S51 MCU produced by Atmel Company is selected as the CPU of the lower computer [8].

The AT89S51 comes in four package configurations. Choose the most popular PDIP (Plastic Dual Inline Package) package, and compared to PLCC and TQFB package, the price is cheaper, circuit wiring is also more simple [9]. As the core part of CPU, it needs to integrate serial communication interface, DEBUS bus cascade interface, ISP

online download interface, serial LCD (Liquid Crystal Display) display interface, key debugging interface and indicator LED (Light Emitting Diode) interface. Make better use of port resources. The main pin definition is shown in Table 1.

**Table 1.** Main pin definition of AT89S51

Pin	Functional features and definitions	Pin	Functional features and definitions
P1.0	CS_ LCD (+): serial LCD chip selection terminal	P1.1	SCLK(System clock): serial LCD clock line
P1.2	SDAT: serial LCD clock line	P1.5	Mosi: ISP online programming data line
P1.6	Miso: ISP (Internet Service Provider) online programming data line	P1.7	SCK ( <a href="#">Studiecentrum voor Kernenergie</a> ): ISP online programming clock line
P3.0	RXD (receive external data): Asynchronous serial transmission output	P3.1	TXD (transmit external data): Asynchronous serial transmission output
P0.0	Idle: DEBUS bus status flag line	P0.5	ResetSon: Wake up connection
P0.6	IIC-SDAT: I <sup>2</sup> C data line	P0.7	IIC-SCLK: I <sup>2</sup> C clock line
RST	ResetSon: System reset, lower computer reset control	P2.5	LEDcontrol port
P2.4	LED control port	P2.3	LED control port
P2.2	Key control port	P2.1	Key control port
P2.0	Key control port		

Under the support of CPU, the system's internal upload, download, information sharing and other functions to provide support.

## 2.2 Serial Communication Hardware Design

Considering the needs of users, the serial communication hardware is designed to provide users with data upload, download, transmission and sharing functions [10].

In the system hardware design using RS-232 serial communication, PC using the RS-232C standard logic level, and AT89S51 using the TTL (Transistor-Transistor Logic) level, level conversion must be carried out. The exchange of levels falls broadly into two categories. One is the use of discrete components, one is the use of chips [11]. Circuit diagrams of discrete components have a lot of information to follow, some of which are quite simple. But this method needs to calculate the electrical index of discrete components according to the serial port of a specific PC. The choice of integrated chip is low cost, less peripheral components, more stable, can simplify the circuit board. Max232 chips are finally selected in the design based on the power supply requirements (SV), power consumption requirements (general), circuit board area requirements (smaller), price (cheapest) and other factors [12].

There are two pairs of drivers/receivers inside the MAX232. One pair, Tin and Rout, is connected to the TXD and RXD pins of the MCU respectively. The other end is connected to the 9-pin interface, which is connected to the serial interface of the PC. External connection of 4 capacitors, with the internal double charge pump to achieve level conversion. According to the function of online download, the hardware circuit of ISP online download is designed.

The concept of the ISP (In System Programming) was initially proposed by Lattice Corporation of the United States, which can directly program the internal memory of the CPU under the condition that the single-chip computer system operates without power. And after the end of the program, the SCM(Software Configuration Management) can restart the operation [13]. Because ISP makes the development process of embedded system more efficient, Atmel company also adds ISP online download function to its mainstream product AT89CSX series SCM. The ISP functional pins of the AT89S51 are P1.5 (MOSI: MASTER OUTPUT SLAVE INPUT), P1.6 (MISO: MASTER INPUT SLAVE OUTPUT), P1.7 (SCK), and their RST(RESET) reset pins are also attached [14].

In order to realize the downloading function of AT89SSX series single chip micro-computer, it needs the cooperation of hardware and application software [15]. The ISP interface for the underlying host is shown in Fig. 1.

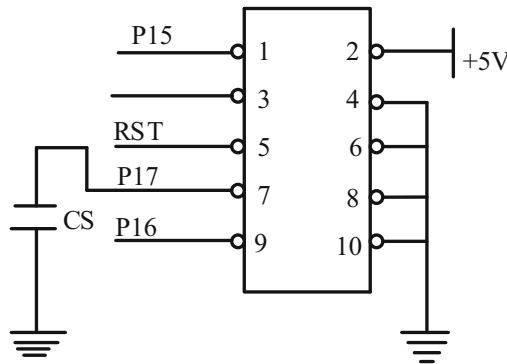

**Fig. 1.** ISP download line interface

According to the above, the DEBUS bus already contains the I2C bus and the status flag line Idle. In order to increase the function of waking up the lower computer, the control line of “ResetSon” is added [16]. The line is directly connected to the RST line of the lower computer. When the lower computer breaks down, it can be restarted by the ResetSon control line. The interface of DEBUS is designed in the form of “cascade”, and the Vcc power line and GND (GrouND) bottom line are added to achieve the goal of “common power supply” and “common ground”. At this point, the DEBUS hardware architecture is complete, totaling six lines: I2C’s data line IIC-SDAT, I2C’s clock line IIC-SCLK, Status Marker Idle, Machine Control Line ResetSon, Bottom Line GND, and Power Line VCCCo. DEBUS Bus interface portions are shown in Fig. 2.

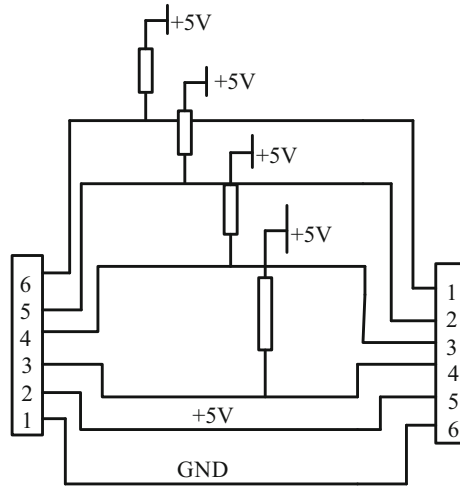

**Fig. 2.** Bus interface circuit

J8 is the cascade terminal, which is the access terminal of each lower computer. Each module of the lower computer has this cascade interface, and all the lower computers can be connected in parallel on the DEBUS bus through the interface. Of the 4 I/O ports of AT89S51, P0 port has the largest IOL, i. e., the strongest drop-down capability, so P0 port is chosen here as the terminal of DEBUS bus. The P0 port has no built-in pullup resistor, so additional pullup resistors are required. At this point, the system hardware design is completed [17].

### 3 Software Design of Innovation and Entrepreneurship Effect Evaluation System for College Students Based on MOA Model

#### 3.1 Storage Mode of Design Effect Evaluation Resources

The evaluation resources of innovation and entrepreneurship often have many forms, such as documents, pictures, videos and so on. Most of these massive digital resources exist in the form of unstructured, and can not be effectively stored with a unified data structure, which easily leads to resource sharing difficulties. In order to achieve the goal of quality innovation and entrepreneurship effect evaluation resource sharing, the first problem to be solved is the description resource [18]. The evaluation of innovation and entrepreneurship effect is to define a standardized and feasible way to describe and package the evaluation resources of innovation and entrepreneurship effect, Realize the unified storage and retrieval of resources. This is the basis of effective resource sharing, so it is necessary to unify and standardize the representation of resources [19].

Defining a consistent data resource description framework through metadata standards is an effective way to solve this problem. Metadata is the description of the data

structure and content characteristics of the original data resources. The purpose of browsing metadata is to access the original data resources, i.e. innovation and entrepreneurship effect evaluation resources. The so-called metadata standard is a set of rules that describe the specific objects of innovation and entrepreneurship effect evaluation resources.

According to the CELTS-42 standard “Metadata Specification of Basic Education Resource”, the data element set of Basic Education Resource includes 22 elements, using the language code specification defined in RFC 1766. The specification allows users to extend metadata elements according to the needs of the system, but must conform to the format and technical specifications defined by the specification elements [20]. According to this specification, the storage mode of system resources is designed as follows:

The resource itself and resource description information of innovation and entrepreneurship effect evaluation should be named with the same file name, and stored in the designated folder of HDFS distributed file system through Hadoop. The resource description information is generated by resource name and resource content configuration file in a fixed format, which is used to generate the index file of retrieval resources [21].

The metadata information of the resource is stored as a record in the MySQL database table, while the location of the resource in HDFS (Hadoop Distributed File System) is recorded and used as a way to download and obtain the resource. Metadata information is used to allow users to view the properties of a resource when it is displayed [22].

Users on the system page can view the metadata information of the resource and the content information of the resource itself (displayed on the page in the form of a preview) and obtain the corresponding resource in HDFS through the storage location field of the resource in the database table when the resource needs to be obtained. The metadata description table ResourceInfo is designed as shown in Table 2.

**Table 2.** ResourceInfo metadata description table

Field name	Field type	Explain
ResourceID	Integer	Resource ID
Title	Varchar (50)	Resource title
UserID	Integer	Resource owner ID
Description	TinyText	Resource description
TypeID	Integer	Resource type
FormatID	Integer	Resource file format size
FileSize	Integer	Resource file size
UploadTime	Date	Resource upload time
Value	Integer	Resource value set by uploader
Download Count	Integer	Resource downloads
ScanCount	Integer	Resource views
Identify	Varchar (255)	Resource index identifier

In the process of evaluation, the system fetches the related information from the resource database, and realizes the effect evaluation of college students' innovation and entrepreneurship [23].

### 3.2 Selection of Evaluation Indicators Based on MOA Model

The MOA model is composed of motivation, opportunity and ability, and their interrelation and interaction promote the occurrence of certain behaviors. Motivation is the college students' willingness to participate in innovation and entrepreneurship activities, and opportunity is the effective component that is conducive to behavior in the external environment. It has positive effect on innovation and entrepreneurship.

Collect the data of college students in the process of innovation and entrepreneurship, process the data by SPSS, analyze the basic situation of the sample, and get the final analysis data by reverse recalculation. Using the concept model to verify and analyze the effect of innovation and entrepreneurship activities of college students, to select the appropriate evaluation indicators. After model verification and calculation, the results are shown in Table 3.

It can be seen from the data in Table 3 that each measurement index meets the evaluation requirements. When the index is known, the weight of each index is calculated.

### 3.3 Evaluation of the Effects of Innovation and Entrepreneurship

The geometric average values of each row of the judgment matrix are calculated by using the product square root method. The formula is as follows:

$$\bar{c}_i = \left( \prod_{j=1}^n a_{ij} \right)^{\frac{1}{n}} \quad i, j = 1, 2, \dots, n \tag{1}$$

In formula (1),  $a_{ij}$  represents the elements in row  $i$  and column  $j$  of the original judgment matrix,  $n$  represents the number of indicators, and  $c_i$  represents the geometric average value in row  $i$  of the original judgment matrix. The geometric mean of each row is normalized to get the feature vector:

$$c_i = \frac{\bar{c}_i}{\sum_{j=1}^n \bar{c}_i} \tag{2}$$

In formula (2),  $c_i$  represents the weight of the  $i$ -th indicator,  $n$  represents the number of indicators, and  $\bar{c}_i$  represents the geometric average value of the  $i$ -th row of the original judgment matrix. The weight coefficient of the first level index is calculated. On this basis, the maximum eigenvalue of the judgment matrix is calculated:

$$\lambda_{max} = \frac{1}{n} \sum_{i=1}^n \frac{\sum_{j=1}^n a_{ij} c_i}{c_i} \tag{3}$$



**Table 3.** Factors load, reliability, validity and normal test results of measurement indexes

First level indicators	Secondary indicators	Factor load	Reliability coefficient	Mean variance extraction
Innovation and Entrepreneurship Environment	External support environment	.702	.493	.426
	School implementation environment	-.393	.154	
	School Entrepreneurship	.795	.632	
Investment in innovation and Entrepreneurship	Construction of teaching staff	.940	.884	
	Current situation of investment	.909	.601	.770
	Construction of practice platform	.775	.501	
Innovation and entrepreneurship process	Curriculum system design	.708	.545	
	Service guidance support	.738	.582	.523
	Student participation process	.763	.741	
Achievements of innovation and Entrepreneurship	social influence	.861	.584	.636
	Educational achievements	.764	.826	

The weights of single-level indicators can be obtained through the above calculation. Based on the above results, an evaluation model is established:

$$Y = \sum_{i=1}^n X_i c_i \quad (4)$$

In formula (4),  $X_i$  represents the score value of the evaluation index and  $c_i$  represents the comprehensive weight of the index. According to the calculation results of formula (4), the effect of innovation and Entrepreneurship of college students is judged. The larger the value is, the better the effect is. On the contrary, the worse the effect is. So

far, the evaluation system of College Students' innovation and entrepreneurship effect based on MOA model has been designed.

## 4 Performance Test of Innovation and Entrepreneurship Effect Evaluation System for College Students Based on MOA Model

### 4.1 Build Test Environment

The system is designed on the basis of multi-layer architecture. The function of each layer is relatively independent. There is a standard interface between each layer. It can not only ensure the scalability, flexibility and openness of the system, but also facilitate the system access and management. In order to verify the application performance of the system, the experimental environment is set up. The hardware environment is shown in Table 4.

**Table 4.** Hardware environment

Hardware type	Purpose	To configure	Number	Operating environment
web application server	Support the retrieval, analysis and other front-end applications	IBM-X3650 M4 CPU:Inter Xeon 4C E5-2609 Memory:ECC DDR3 128G	2	Windows 2010
Interface application server	Middle layer encapsulation service of retrieval interface	IBM-X3650 M4 CPU: Inter Xeon 4C E5-2609 Memory: ECC DDR3 128G	1	Centeos
Load balancing server	Realize load optimization and resource allocation in the process of big data loading and big user concurrency	IBM-X3650 M4 CPU: Inter Xeon 4C E5-2609 Memory: ECC DDR3 128G	1	Centeos

Under the support of the above environment, the test results evaluate the performance of the system. System testing is a process used to test the integrity, correctness and security of software. It is an indispensable part of software development. In order to ensure the quality and reliability of the evaluation system of College Students' innovation and entrepreneurship effect, functional testing and performance testing are carried out on the system. The function test is mainly to test whether each functional module of the system meets the requirements, and the performance test is mainly comparative test. Two traditional evaluation systems are introduced in the test to verify the actual level of each system under the same test conditions, including load stress test and concurrent test.

## 4.2 System Function Test

The function test of the evaluation system for college students' innovation and entrepreneurship effect adopts the method of unit test, which runs through all stages of the system development, that is, every functional module is developed and tested to ensure its accuracy. Test cases include normal input, boundary input and abnormal input. The output of each module of the test system meets the requirements under different conditions, and the system is improved according to the test cases.

The test of evaluation data acquisition and management module mainly includes the upload of test data, the information editing, modification and deletion of uploaded data. The test contents are shown in Table 5.

**Table 5.** Test of data upload and management module

Test content	Input	Expected results	Actual output
Resource upload	Select a file and confirm the upload	Prompt that the upload is successful, call to the resource information editing page	In line with expectations
Edit resource information	Enter the editing information and confirm the editing	Prompt to edit successfully, jump to the uploaded resource list	In line with expectations
Modify resource information	Enter the modification information and confirm the modification	If the modification is successful, skip to the uploaded resource list	In line with expectations
Delete resource	Select a data and click delete	Prompt to delete successfully	In line with expectations

For the test of effect evaluation module, the main function is to test evaluation resources and view other evaluation content. The test contents and results are shown in Table 6.

**Table 6.** Effect evaluation module test

Test content	Input	Expected results	Actual output
View comments	Click the resource icon	The resource details page displays all the user's comments	In line with expectations
Evaluation resources	Evaluation content	Evaluate success	In line with expectations

Evaluation information classification management module test, the administrator to view the evaluation information classification, add, delete, modify information classification functions. The test contents are shown in Table 7.

**Table 7.** Testing of the evaluation information resource category management module

Test content	input	Expected results	Actual output
Get resource category	Click manage resource category	Get resource type	In line with expectations
Add resource category	Enter the resource name and confirm to add	Increase success	In line with expectations
Modify resource category	Select the category, enter the modification name and confirm the modification	Modified successfully	In line with expectations
Delete resource category	Select category and confirm deletion	Successfully deleted	In line with expectations

Through the above functional tests, we can see that the system functions are able to meet the normal implementation, there is no abnormal situation. On this basis, comparative experiments can be carried out to further verify the actual level of the evaluation system.

### 4.3 System Load Capacity Testing and Analysis

Load test mainly tests whether the load pressure of the system meets the requirement under the condition of high concurrent access. Web Bench is used to complete the load stress test of the system server. Web Benceh is a website stress testing tool developed by Lionbridge. It can be used to test the server stress of ASP, PHP, JAVA, CGI, etc. It can also be used to test the load capacity of SSL secure websites. It can simulate up to 30,000 concurrent links to test the load capacity of websites. The traditional effect evaluation systems 1 and 2 are compared with the systems mentioned in the documents [7] and documents [8]. The test results are shown in Table 8.

Through the data in Table 8, it can be seen that the traditional effect evaluation system 1 increased the number of request failures significantly with the increase of test time, and reached 415 request failure links at 50 s, indicating that the system has poor load capacity and can not meet the needs of continuous request access. In the traditional evaluation system 2, when dealing with 1000 requests, with the increase of test time, the rate of request failure is also very obvious. 526 request failure links are reached in 50 s, which indicates that the system load capacity is poor and it is difficult to meet the needs of continuous request access. In the face of a large number of requests, the design system can ensure the success of all requests in the 50 s, indicating that the system can meet the continuous concurrent access in a certain period of time. The results show that

**Table 8.** Load test results of different effect evaluation systems

	Number of requests	Test time	Number of requests failed
Traditional effect evaluation system 1	1000	10	11
	1000	20	65
	1000	30	124
	1000	40	206
	1000	50	415
Traditional effect evaluation system 2	1000	10	24
	1000	20	92
	1000	30	187
	1000	40	294
	1000	50	526
The evaluation system proposed in this paper	1000	10	0
	1000	20	0
	1000	30	0
	1000	40	0
	1000	50	0

the evaluation system of College Students' innovation and entrepreneurship effect has good pressure resistance ability.

#### 4.4 System Concurrency Test Results and Analysis

The system uses Apache JMeter to test concurrency. The concurrency test runs a stress test for about 60 s with different number of threads and different loops.

Observing the data in Table 9, we can see that the system access error rate of the traditional effect evaluation system 1 increases gradually when the thread number setting increases in turn, and reaches more than 50% when it increases to 1000, which is basically unbearable, and the throughput drops obviously, which can not maintain the high application level in the high thread. Traditional evaluation system 2 faces the situation that the number of threads is increasing continuously, but it also has the situation that the system access rate is increasing. When it increases to 1000, the system error rate reaches more than 60%, the system can not run normally, and the throughput drops more obviously. This shows that it is difficult for the system to keep good performance when the number of threads increases. However, with the increase of the number of threads, the error rate of design system access remains at a very low level of 0.5%, and the throughput does not decline significantly, and it always remains at a high level. Load performance test results show that the system based on MOA model has good adaptability and can be effectively applied to multi-party collaborative environment.

**Table 9.** System concurrency test results

	Number of threads	System access error rate%	Throughput (KB/sec)
Traditional effect evaluation system 1	200	0.95	107.16
	400	7.45	73.13
	600	12.17	64.14
	800	26.47	58.92
	1000	51.42	43.61
Traditional effect evaluation system 2	200	0.57	119.62
	400	9.26	94.32
	600	22.54	61.55
	800	43.36	54.23
	1000	62.34	41.45
The evaluation system proposed in this paper	200	0.26	358.5
	400	0.30	307.6
	600	0.51	277.8
	800	0.60	243.6
	1000	0.63	215.4

## 5 Concluding Remarks

In this paper, with the support of the original research data and literature materials, the MOA model-based evaluation system of college students' innovation and entrepreneurship effect is designed, which provides more possibilities for college students' innovation and entrepreneurship education. After the system design is completed, the high adaptability of the evaluation system is verified through a large number of comparative experiments, and the problems existing in the traditional evaluation system are solved. However, due to the limitation of time and technology, the system still has some shortcomings. The basic education of innovation and entrepreneurship involves a wide range, so it is possible to choose the evaluation index. Therefore, in the follow-up research, we will further improve the evaluation indicators and content, promote the improvement of innovation and entrepreneurship education level of college students, so as to achieve the purpose of carrying out satisfactory vocational education.

**Fund Projects.** Humanities and social sciences research project of Jilin Provincial Department of Education (JKH20211399JY).

## References

1. Zhang, Y.: Assisted teaching quality evaluation model based on active learning support vector machine. *Mod. Electron. Tech.* 42(07), 112–114 (2019)

2. Zhang, J., Wang, Y., Yu, L.: Teaching and assessment practice of the course of theoretical mechanics uniting four types of classrooms. *Mech. Eng.* **41**(02), 210–215 (2019)
3. Yu, J., Feng, Q., Ding, X.: A new exploration of academic evaluation system for college students based on CIPP and CDIO model. *Heilongjiang Res. High. Educ.* **37**(03), 52–56 (2019)
4. Wei, D., Wei, X.: Design of network experimental teaching evaluation system based on data mining. *Mod. Electron. Tech.* **43**(03), 142–145+149 (2020)
5. Nan, G., Hou, Z., Liu, K.: Construction of evaluation model of college students' entrepreneurial opportunity based on entropy weight method. *J. Hefei Univ. Technol. (Nat. Sci.)* **43**(12), 1713–1717 (2020)
6. Xu, Z., Yang, L., Luan, S.: Research on evaluation of transformation ability and efficiency of scientific and technological achievements in universities based on relay innovation. *Sci. Technol. Manage. Res.* **39**(24), 8–14 (2019)
7. Dang, J., Wang, D., Jing, T.: Design of entrepreneurship education evaluation system based on digital badge technology. *E-educat. Res.* **41**(09), 75–80+101 (2020)
8. Dong, Q., Dai, G.: Evaluating system of learning effect based on fuzzy comprehensive evaluation. *Math. Pract. Theo.* **50**(05), 282–291 (2020)
9. Han, S., Li, R.: Kansei engineering based evaluation for the designation of products on electronic commerce website. *J. Univ. Shanghai Sci. Technol.* **41**(01), 97–102 (2019)
10. Zhang, J., Li, J., Chen, H.: Research on the performance evaluation and influencing factors of scientific research innovation in universities across the Yangtze River delta: based on DEA-Malmquist-Tobit Model. *Sci. Technol. Manage. Res.* **40**(09), 80–87 (2020)
11. Yan, X., Tian, J.: Evaluation model of college students' entrepreneurship success rate based on grey relational theory. *E3S Web Conf.* **235**(25), 03019 (2021)
12. Xin, M., Wang, Y., Fan, L., et al.: On the construction of evaluation system for undergraduate college students' ability of innovation and entrepreneurship. *J. Heihe Univ.* **10**(09), 105–107 (2019)
13. Yuan, L., Sun, Z., Sun, Z., et al.: Evaluation of college students' innovation and entrepreneurship ability in maker space. *Theo. Pract. Innov. Entrepreneurship* **2**(02), 20–22 (2019)
14. Zhang, F., Xi, L.: An evaluation model for the innovation and entrepreneurship thinking ability of college students based on neural network. *Int. J. Emerg. Technol. Learn. (iJET)* **16**(2), 188 (2021)
15. Liu, R., Guo, J., Daytime charming: Research on the current situation and countermeasures of college students' innovation and entrepreneurship curriculum system—taking Xi'an University of engineering as an example. *Educ. Forum* **000**(014), 122–124 (2019)
16. Xin, Y., Wang, C., Dong, Y., et al.: Management and entrepreneurship management mechanism of college students based on support vector machine algorithm. *Comput. Intel. IP(IP)*, 1–13 (2020)
17. Chen, Y.: College English Teaching quality evaluation system based on information fusion and optimized RBF neural network decision algorithm. *J. Sens.* **2021**(5), 1–9 (2021)
18. Qi, Y., Liang, T., Chang, Y.: Evaluation of college students' innovation and entrepreneurial ability for the science and technology service industry. *Int. J. Emerg. Technol. Learn. (iJET)* **16**(5), 228 (2021)
19. Wang, K., Yan, C.: An evaluation model for the cultivation and improvement of the innovation ability of college students. *Int. J. Emerg. Technol. Learn. (iJET)* **15**(17), 181 (2020)
20. Li, N.: A fuzzy evaluation model of college English teaching quality based on analytic hierarchy process. *Int. J. Emerg. Technol. Learn. (iJET)* **16**(2), 17 (2021)
21. Lei, H., Qin, L.: Effect analysis of the field management innovation of SERVQUAL model evaluation in pro-motion of outpatient service upgrade. *Pract. J. Clin. Med.* **016**(004), 233–235 (2019)

22. Gupta, H., Barua, M.K.: Evaluation of Manufacturing Organizations Ability to Overcome Internal Barriers to Green Innovations (2021)
23. Soltanzadeh, J., Elyasi, M., Ghaderifar, E., et al.: Evaluation of the effect of R&D subsidies on Iranian firms' innovative behavior: reconceptualizing behavioral additionality. *J. Sci. Technol. Policy Manage.* **11**(1), 17–48 (2019)