

House Loti



Audrey Mertens, Chen Qi, and Fantine Fontaine

Abstract Designed to promote and demonstrate the utility of bamboo in architecture and engineering, House Loti takes the form of a blossoming lotus. The authors came together to propose a pavilion that takes inspiration from traditional bamboo, and rattan craftsmanship. We sought to deliver a project which is utilitarian, adaptable, and able to be rapidly assembled. The final project was assembled by 4 people under 24 man-hours, installed on-site at INBAR Pavilion at the 2019 Beijing Horticultural Expo.

Keywords Bamboo · House Loti · Pavilion

1 Design Concept

1.1 Context and Brief

For the 2019 International Bamboo Construction Competition, the building was to be designed as a singular pavilion within a 3 m by 3 m footprint, under 6 m tall. The brief asked for shelter which can be adapted for different functions including the ability to rest.

Expanding on the objective goal of the project, there also exists a strong theme that we must demonstrate. The project should utilize bamboo primarily, and given the nature of the International Bamboo and Rattan Organisation (INBAR), the building should sustain a strong overarching concept which experiments with and celebrates the properties of bamboo.

A. Mertens (✉) · F. Fontaine

Urban and Environmental Engineering Department, University of Liège, Liège, Belgium

C. Qi

Faculty of Environment and Technology, University of the West of England, Bristol, UK

Fig. 1 3D model of the pavilion as designed



1.2 Spatial Design

Given the unique nature of a pavilion, our spatial response to the brief was one of independence. The building is in essence without context, able to be temporarily or permanently installed anywhere. As such, our building would have a ground floor area that is welcoming when approached from any direction. Further, emphasized with the modular collapsible “petals” of the façade, the proposed project allows the user to adjust their exposure to the environment (Fig. 1).

The stand the team is taking here is to promote creative typologies, which is the way to put bamboo on the map as a construction material for other buildings in the future.

Contrasting against the ground floor, a smaller second-level area is designed to create a sense of privacy. Accessed via a ladder, the second level exists in a dichotomy to the ground floor; the area is enclosed with a fixed building envelope, and a series of traditional rattan weave provides a shelter from light and heat.

1.3 Structure and Construction

The construction response captures two main purposes of the building, primarily it should fully utilize the unique properties with bamboo while secondarily the structure should be easily constructible on site.

The main framework of the building sees the use of six bundles of natural bamboo, beginning at the foundation and meeting at their apex. The tensile property of the bamboo allows the building to sit in constant tension, such tension would resist any variable horizontal load including wind or people standing against it.

This hexagonal symmetry allows six equal sections of the building to be prefabricated. As seen in Fig. 2, each symmetrical section of the building consists of a

Fig. 2 Layout plan of the design

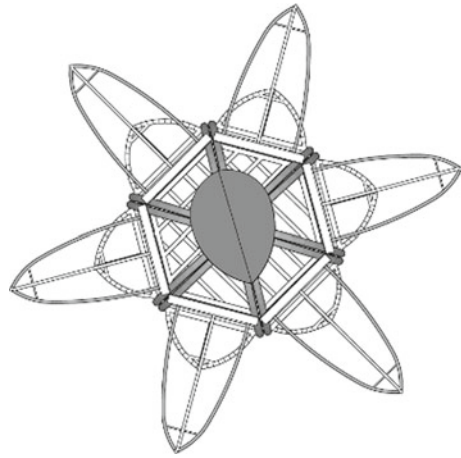

self-contained module with two vertical main bamboo columns and two horizontal bracing components.

The entire structure sits above 6 foundational concrete blocks cast in-situ. Each of these blocks hosts a vertical steel tube to which the vertical bamboo columns will attach to. This allows the building to be quickly installed with minimal tools.

1.4 Material

The exploded axonometric drawing in Fig. 3 displays the detailed strategy. Each panel can be broken down into 3 main materials: bamboo, rattan, and fabric.

Bamboo is used in the project as the main load-bearing component. Bamboo experiences both compressional and tensile stress in the pavilion. Bamboo also allows for circular incisions to be made to allow for either friction joints or the creation of movable hinges such as the component used in the “petals” of the building.

Rattan functions as the secondary structure and as a layer of cladding on the building. This provides marginal bracing for the bamboo and shelters the building from the sun. It also acts as a secondary structure to which the weatherproof fabric layer would be attached.

Waterproof Fabric is used to provide shelter from the rain, sun, exposure, and moisture. As prescribed by Kaminski et al. [1], bamboo should not be exposed to water nor rain. Thus, this fabric protects the structure from direct rain, to prevent the bamboo from rotting, poles must be treated before implementation.

Attached to the exterior of the building, combined with the rattan weave provides a lightweight cladding solution for the pavilion. It is also easily repairable using spare material with primitive tools. However, due to the unavailability of a fit fabric at the time, the entrepreneur in charge of prefabrication of the panels replaced it

Fig. 3 Exploded axonometric scheme of the layers and components of the structure

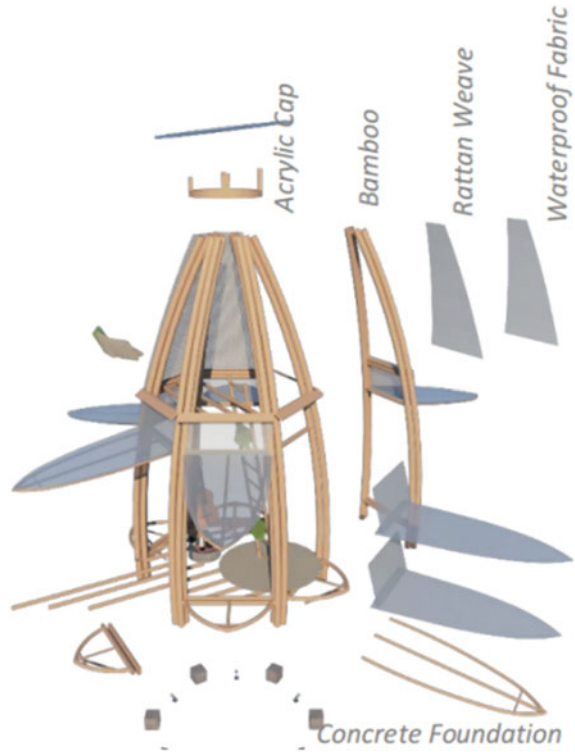

with a Plexiglas layer, therefore still protecting the bamboo structure from rain and maintaining the design will keep partial transparency of the wall cladding.

1.5 Kinetic Facade

The ground level of the building is sheltered by 6 symmetrical “petals”, each attached to a module of the building. A steel cable attaches through a pulley system to the mid-point of each petal, the 6 cables are threaded through a secondary pulley at the pinnacle of the structure, down through a stabilizing component as shown in Fig. 4. These cables are wound through a hand crank in the interior of the building, where it can be operated by a single person. This mechanism allows the petals to be opened, closed, or secured at any position in between.

Fig. 4 Principle diagram for the cables allowing to lift the “petals”

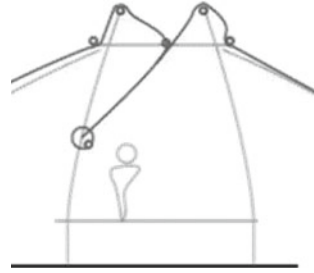

1.6 Site Strategy

While the current project is designed for a pavilion setting, where a single installation is created, we foresee possibilities for wider implementation of the design. One potential use of these pavilions is at designated camping areas in national parks or natural resorts. This allows a variable amount to be placed, adaptable to a range of different densities. While the current construction is not suitable for more than a couple of overnight stays, we are confident it can be adapted and improved to provide more permanent shelter when required.

2 Design Development

2.1 Foundation Design

For the 2019 International Bamboo Construction Competition, the building was to be designed as a singular pavilion within an area of 9 m² (3 m by 3 m), as well as a projection area no larger than 16 m² (4 m by 4 m), including cantilever structural elements such as canopy.

As previously explained, bamboo should not be exposed to water nor the humidity from the soil [1]. To prevent the bamboo from rotting, foundations are made of concrete.

Thus, to be as economical as possible in non-renewable materials such as concrete and steel, the foundations of the House Loti were kept to a minimum of 6 concrete studs, each one topped by steel anchors to bolt the bamboo pole to, positioned in a 3 m wide hexagon. As shown in Figs. 5 and 6 small additional concrete studs serve as holders for the seating’s legs.

Fig. 5 Foundation layout

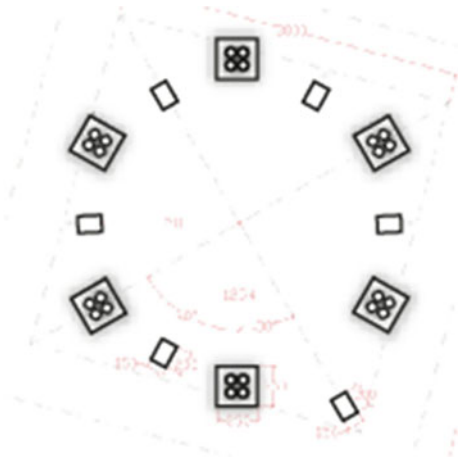
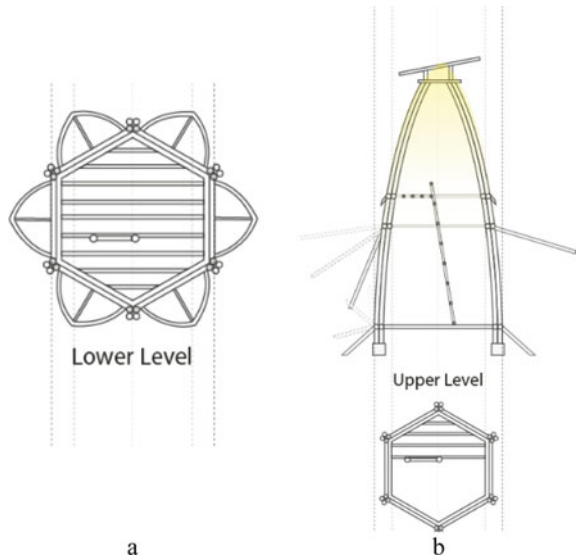

Fig. 6 Layouts and cross section of the pavilion:
Lower level (a); upper level (b)



2.2 Ground Floor Design

The ground floor consisted of a hexagonal main deck, with laminated bamboo flooring. Rotatable bamboo petal-shaped seating can unfold and create extra flooring or a nice stop to sit on, accessible from the exterior of the structure. These seating have a small bamboo pole used as a leg to support the deck. These supports fit in a notch, provided for that purpose in the concrete studs below. The entry of the pavilion lies in one of these petals, which is legless, and which contacts the ground directly

and creates a small ramp to climb onto the main deck of the building. Unfolded, the floor plan recalls the shape of a flower.

This floor is as polyvalent as can be: the deck is vast, regarding the mission statement's constraints, creating a comfy little reunion spot, sheltered from the rain whilst still well ventilated and open to the exterior for sunnier days. It can also be used as 5 different meeting spots for couples meeting on different petals, taking a break, tea, or lunch. If closed, the lotus can also be a nice place for self-examination, to meditate or just to chill. The floor plan is shown in Fig. 6a.

2.3 Second Floor Design

The second floor is a small mezzanine bamboo floor, taking up just half of the hexagonal shape of the building, thus leaving a full height and view of the ceiling for half of the ground floor. It is accessible by a steady ladder, allowing one person at a time to come up and enjoy this small bamboo nest. This upper floor plan is shown in Fig. 6b.

A small basket, hanging on a pulley, allows you to conveniently carry your belongings up with you, without having to carry them whilst going up the ladder. It is a nice spot to get a glance at the view, taking a bit of height. It is a place to store stuff or to rest a little by yourself.

2.4 Ceiling Design

A round sky-opening connects the 6 panels. This hole allows the air to flow through the building and up. A small plexiglass leaf-shaped screen is mounted on the very top of the structure, completing its uniquely natural look, and sheltering the volume of the building from the rain.

2.5 Facade Design

The entire shape of the building evokes the delicacy of a lotus flower. Arches not only highlight the flexibility characteristics of bamboo; it is also very soothing for the eye. The facade features 6 kinetic elements as mentioned before and creates a distinct appearance and flexibility of function for the building. Figure 7 demonstrates the profile of the building when the kinetic elements are opened and closed. A photographic depiction of the facade can be found in Sect. 4.

The transparency of the structure allows a lot of light in. The rattan weave not only gives the building a unique look but it also values local craftsmanship and provides a visual cladding from a distance into the building whilst still allowing full

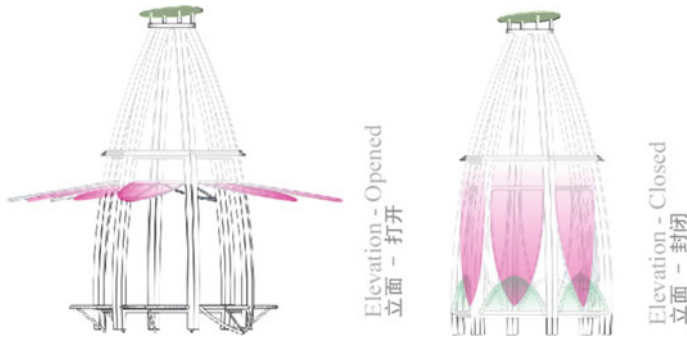

Fig. 7 Elevations of the building

vision out. The kinetic elements allow us to adjust the level of privacy, exposure, weatherproofing, circulation, and footprint of the building, making it suitable for a wide range of locales and functions.

2.6 Structural Approach

The calculation of the structure was guided by methods taught at the firm ASALI BALI during their bamboo construction workshops and by Kaminski et al. writings [2–4]. The calculation is based on the ISO standards and Eurocodes [5–8].

To check the deformation of the pavilion, the structure was modelled with Rhino 3D and the Grasshopper plugin. Then, it was transferred to Autodesk software ROBOTO, entering Moso bamboo’s properties manually for simple tubular beams. The results verified the resistance of the structure for all elements in compression, tension, and bending and gave a maximal displacement at the top of the structure equal to 5.9 cm. This displacement, corresponding to $H/93$, was considered acceptable for a temporary building.

The authors want to highlight the fact that the design was several times presented to local Balinese entrepreneurs and the architect Made Wirahadi Purnawan, to get iterative feedback on versions of the design. This expert advice, together with the knowledge brought up by craftsmen working daily with bamboo, its forces, and constrains, really enriched this design process way more than any engineering calculation could have.

3 Construction

3.1 Pre-fabrication

The initial step of construction happens off-site. We sent the contractor a Sketch Up module containing all bamboo components of the building. The building is broken down and manufactured as independent components, then assembled in the factory to create 6-panel modules. The detailed construction is as follows, as shown in Fig. 8.

3.2 Module Delivery

The structure is made of six frames that are assembled with rope on-site into a hexagonal shaped plan, primary floor structure, and end cap on top. Each frame was prefabricated by the contractor off-site and brought on-site by truck. The frames can be carried by hand by 3 men.

3.3 Foundation Casting

The foundation is cast on-site as semi-submerged concrete blocks (Fig. 9a). During casting, stainless-steel tubes are inserted into the foundation. This will allow main structural bamboo columns to be inserted onto the foundation. Elevation of the base of the bamboo above ground to prevent weathering damage.

3.4 Module Preparation

During transit, the prefabricated panels (Fig. 9b) are braced with additional elements. These are bamboo strips running perpendicular to the modules, nailed in place. It also secures the kinetic facade in place. Prior to the installation, we will extract these bracing elements and test the hinges of the petals.

3.5 Initial Module Installation

To begin the installation, we erect a single module with 3 people, inserting the bamboo into the foundation cast (Fig. 10). Ensuring that both sides of the panel rest fully on the foundation, a single bamboo pole would be used to support this module as we begin to work on the other modules.



a

Step 1: Cylindrical bamboo is cut to size as needed in the building. The primary beams are pre-stressed to create a slight bend.



b

Step 2: Cap is created. A single piece of die-cut stainless steel is bent to create a crown. A leaf-shaped acrylic element is laser-cut.

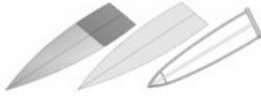

c

Step 3: Separate from the main structure, the petals are created. Rattan is attached to the surface of panels. An acrylic sheet is used for the exterior instead of fabric, that was a compromise we agreed with the contractor due to a lack of material.

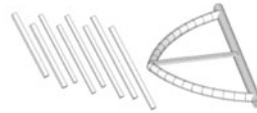

d

Step 4: Adjustable steps are created separate from the main building. Pre-stressed bamboo forms the frame while bamboo sliced in half vertically is installed as the decking.



e

Step 5: The main module frames are created out of bamboo. The petals and adjustable steps are inserted into slots on the main bamboo columns.



f

Step 6: Rattan is laid onto the upper section of the frame and secured in place. A layer of acrylic is added above.

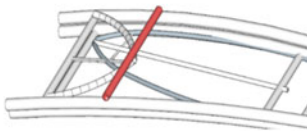

g

Step 7: Temporary bracing is added to the structure to allow the petals to stay in place during transport to the competition ground.



h

Step 8: The modules are bonded to each other using additional temporary braces. This is loaded onto a flatbed truck with additional support.

Fig. 8 Steps for construction

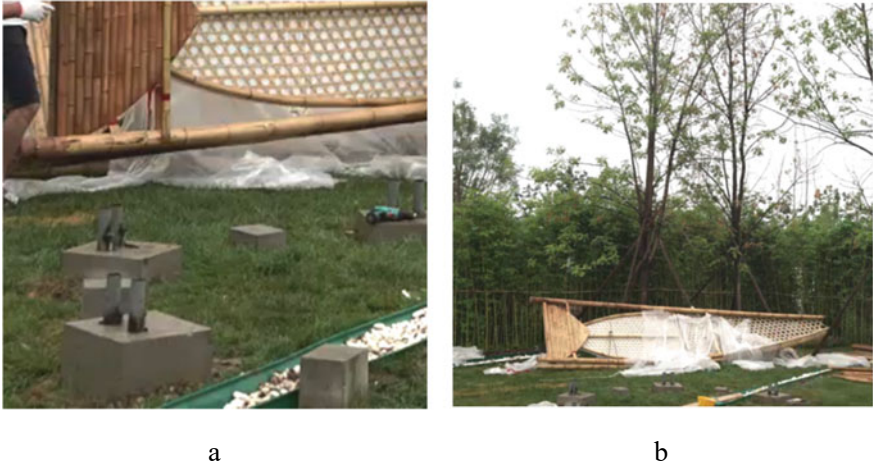

Fig. 9 Casted foundations (a); prefabricated panels (b)



Fig. 10 Module preparation (a); initial module installation (b)

3.6 Adjacent Module Installation

The panels are installed one by one. During this phase of construction, we do not secure any module to its adjacent counterpart (Fig. 11a). This demonstrates the advantage of the tensile module frame, as each module can support itself independently of others.



Fig. 11 Adjacent module installation (a); complete the modules (b)



Fig. 12 Adjacent module connection (a); installation of ceiling element (b)

3.7 Complete the Modules

We install each of the modules onto their foundation. We use grass ropes to temporarily secure the components to each other, marking out positions to install bolts. These ropes are later removed once the bolts are installed (Fig. 11b).

3.8 Adjacent Module Connection

Bolts are installed to secure each module to one another (Fig. 12a). Whereas the timber columns provide vertical load-bearing, these bolts provide bracing against any variable lateral load including wind, or any person leaning against the building.

3.9 Installation of Ceiling Element

The roof element includes a prefabricated module of a stainless-steel crown, capped by a slanted acrylic panel (Fig. 12b). This provides resistance against rain while allowing air circulation between the interior and exterior of the building.

3.10 Threading Cable

From the middle of the petals, we secured steel cables that ran through the pinnacle of the pavilion. A series of pulleys provides a point of support. These 6 cables join into a singular cable (Fig. 13a).

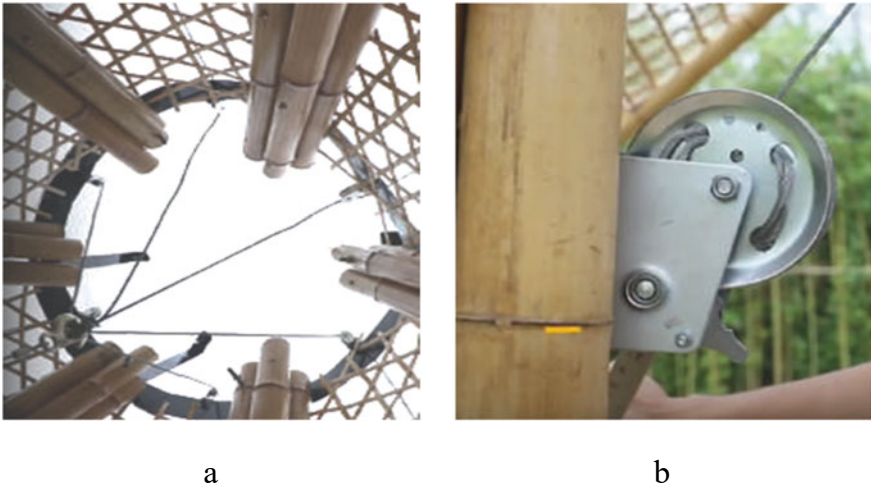

Fig. 13 Threading cable (a); connecting cables to winch (b)

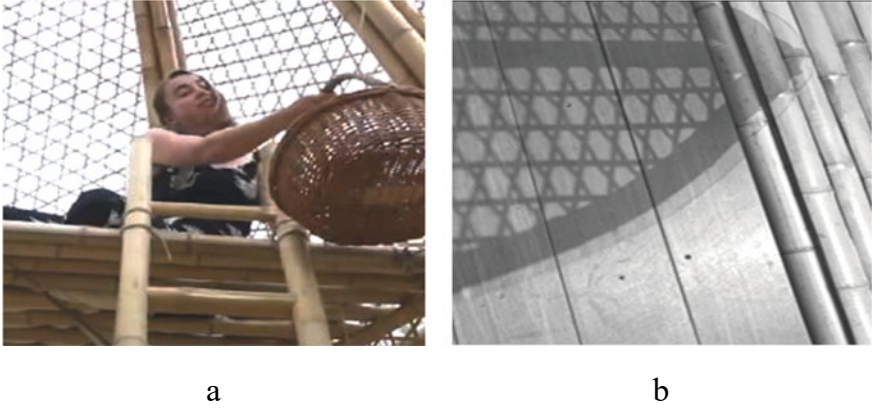

Fig. 14 Upper-level flooring (a); lower-level flooring (b)

3.11 Connecting Cables to Winch

The singular cable is threaded through a winch at one of the columns on the interior of the building. This winch has a self-locking mechanism to allow analog adjustments to the angle of the petals (Fig. 13b).

3.12 Upper-Level Flooring

The upper-level floor (Fig. 14a) consists of a series of cylindrical bamboo decking. This provides a rigid platform as well as additional lateral bracing for the building. A bamboo ladder is placed to allow access to this level. As well as a pulley to retrieve items.

3.13 Lower-Level Flooring

The lower-level floor (Fig. 14b) consists of cross-laminated bamboo beams. This provides a rigid platform, enough to support a group of people. A small gap is left to allow for thermal expansion and contraction. It also provides additional lateral bracing.



Fig. 15 Final look of the constructed pavilion

4 Photos

The final look of the pavilion is shown in Fig. 15.

5 Discussion

This construction was a huge event in all three of the authors' careers as it was the very first time, we had to handle alone all of the constraints of the design from the very beginning, programming to conducting the worksite and construction on a 1:1 scale. The 2019 International Bamboo Construction Competition was a unique opportunity for us to grow and learn from an actual experience focussing on the constraints and forces that a material has to offer. We were the only team amongst the finalist to take bamboo's bending properties not as a weakness but as a force bringing the curves and shapes of natural bamboo into the design of the structure.

The entrepreneur in charge of building the structure had understood that and the cooperative relationship brought us to eventually win the competition [9]. The original and organic shape was mentioned as a key factor in the jury's final choice, as well as the fact that we had taken advantage of the natural raw bamboo poles in the design.

Again, we want to highlight the fact that close interaction and collaboration between bamboo craftsmen and designers is essential in the development of these organic typologies of buildings.

References

1. Kaminski, S., A. Lawrence, and D. Trujillo. 2016. Structural use of bamboo. Part 1: Introduction to bamboo. *The Structural Engineer* 94 (8): 40–43.
2. Kaminski, S., A. Lawrence, D. Trujillo, and C. King. 2016. Structural use of bamboo. Part 2: Durability and preservation. *The Structural Engineer* 94 (10): 38–43.
3. Kaminski, S., A. Lawrence, D. Trujillo, I. Feltham, and L.F. López. 2016. Structural use of bamboo. Part 3: Design values. *Structural Engineer* 94 (12): 42–45.
4. Kaminski, S., A. Lawrence, D. Trujillo, I. Feltham, L.F. López. 2017. Structural use of bamboo. Part 1: Element design equations. *Structural Engineer* 95 (3): 24–27.
5. European Committee for Standardization. 1995. EN: 384:1995 Structural timber. Determination of characteristic values of mechanical properties and density.
6. European Committee for Standardization. 1995. NF EN 1995—Eurocode 5—Design of timber structures Part 1-1: General-Common rules and rules for buildings.
7. International Organization for Standardization. 2004. ISO 22156:2004 Bamboo—Structural design.
8. International Organization for Standardization. 2004. ISO221557-1:2005 Bamboo—Determination of physical and mechanical properties.
9. INBAR. Full results of the International Bamboo Construction Competition. Retrieved from <https://www.inbar.int/full-results-of-the-international-bamboo-construction-competition>.