



Entity Relative Position Representation Based Multi-head Selection for Joint Entity and Relation Extraction

Tianyang Zhao¹✉, Zhao Yan², Yunbo Cao², and Zhoujun Li¹

¹ State Key Lab of Software Development Environment,
Beihang University, Beijing, China
{tyzhao,lizj}@buaa.edu.cn

² Tencent Cloud Xiaowei, Beijing, China
{zhaoyan,yunbocao}@tencent.com

Abstract. Joint entity and relation extraction has received increasing interests recently, due to the capability of utilizing the interactions between both steps. Among existing studies, the Multi-Head Selection (MHS) framework is efficient in extracting entities and relations simultaneously. However, the method is weak for its limited performance. In this paper, we propose several effective insights to address this problem. First, we propose an entity-specific Relative Position Representation (eRPR) to allow the model to fully leverage the distance information between entities and context tokens. Second, we introduce an auxiliary Global Relation Classification (GRC) to enhance the learning of local contextual features. Moreover, we improve the semantic representation by adopting a pre-trained language model BERT as the feature encoder. Finally, these new keypoints are closely integrated with the multi-head selection framework and optimized jointly. Extensive experiments on two benchmark datasets demonstrate that our approach overwhelmingly outperforms previous works in terms of all evaluation metrics, achieving significant improvements for relation F1 by +2.40% on CoNLL04 and +1.90% on ACE05, respectively.

1 Introduction

The entity-relation extraction task aims to recognize the entity spans from a sentence and detect the relations holds between two entities. Generally, it can be formed as extracting triplets (e_1, r, e_2) , which denotes that the relation r holds between the head entity e_1 and the tail entity e_2 , i.e., (*John Smith*, *Live-In*, *Atlanta*). It plays a vital role in the information extraction area and has attracted increasing attention in recent years.

Traditional pipelined methods divide the task into two phases, named entity recognition (NER) and relation extraction (RE) [3, 15, 18]. As such methods neglect the underlying correlations between the two phases and suffer from the

T. Zhao—Work done during an internship at Tencent.

error propagation issue, recent works propose to extract entities and relations jointly. These joint models fall into two paradigms. The first paradigm can be denoted as $(e_1, e_2) \rightarrow r$, which first recognizes all entities in the sentence, then classifies the relation depend on each extracted entity pairs. However, these methods require enumerating all possible entity pairs and the relation classification may be affected by the redundant ones. While another paradigm is referred as $e_1 \rightarrow (r, e_2)$, which detects head entities first and then predicts the corresponding relations and tail entities [2, 14, 26]. Comparing with the first paradigm, the second one can jointly identify entities and all the possible relations between them at once. A typical approach is the Multi-Head Selection (MHS) framework [2]. It first recognizes head entities using the BiLSTM-CRF structure and then performs tail entity extraction and relation extraction in one pass based on multiclass classification. The advantage of the MHS framework is obvious - it is efficient to work with the scenario, that one entity can involve several relational triplets, making this solution suitable for large scale practical applications. In this paper, we focus on the second paradigm of the joint models, especially on the MHS framework.

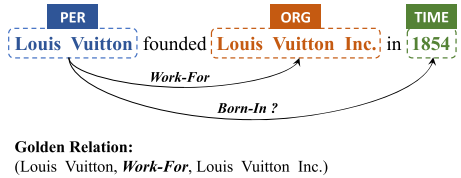

Fig. 1. An example to show the impact of entity-specific relative position.

Despite the efficiency of the MHS framework, it is weak for the limited performance compared with other complex models. Intuitively, the distance between entities and other context tokens provide important evidence for entity and relation extraction. Meanwhile, the distance information of non-entity words is less important. As shown in the sentence of Fig. 1, the “Louis Vuitton” that is far from the word “Inc.” is a person entity, while the one adjacent to “Inc.” denotes an organization. Such an entity-specific relative position can be a useful indicator to differentiate entity tokens and non-entity tokens and enhance interactions between entities. While the existing model pays equal attention to each context tokens and ignores the relative distance information of entities. As a result, the entity-specific features may become less obscure and mislead the relation selection. Second, the existing model predicts the relations and tail entities merely based on the local contextual features of the head entity, and the incomplete local information may confuse the predictor. While the semantic of the whole sentence always has a significant impact on relation prediction. For example, in Fig. 1, the relation between “Louis Vuitton” and “1854” may easily be mislabeled as “Born-In” without considering the meaning of the whole sentence. Therefore, the global semantics should also be taken into account.

To address the aforementioned limitations, we present several new key points to improve the existing multi-head selection framework. First, we propose an entity-specific Relative Position Representation (eRPR) to leverage the distance information between entities and their contextual tokens, which provides important positional information for each entity. Then, in order to better consider the sentence-level semantic during relation prediction, we add up an auxiliary Global Relational Classification (GRC) to guide the optimization of local context features. In addition, different from the original MHS structure, we adopt the pre-trained transformer-based encoder (BERT) to enhance the ability of semantic representations. Notably, the proposed method can address the entity and multiple-relation extraction simultaneously and without relying on any external parsing tools or hand-crafted features. We conduct extensive experiments on two widely-used datasets CoNLL04 and ACE05, and demonstrate the effectiveness of the proposed framework.

To summarize, the contributions of this paper are as follows:

- We propose an entity-specific relative position representation to allow the model aware of the distance information of entities, which provides the model with richer semantics and handles the issue of obscure entity features.
- We introduce a global relation classifier to integrate the essential sentence-level semantics with the token-level ones, which can remedy the problem caused by incompleting local information.
- Experiments on the CoNLL04 and ACE05 datasets demonstrate that the proposed framework significantly outperforms the previous work, achieving +2.40% and +1.90% improvements in F1-score on the two datasets.

2 Related Work

In this section, we introduce the related studies for this work, entity and relation extraction as well as the positional representation.

Entity and Relation Extraction. As a crucial content of information extraction, the entity-relation extraction task has always been widely concerned. Previous studies [3, 15, 18] mainly focus on pipelined structure, which divides the task into two independent phases, all entities are extracted first by an entity recognizer, and then relations between every entity pairs are predicted by a relation classifier. The pipelined methods suffer from error propagation issue and they ignore the interactions between the two phrases. To ease these problems, many joint models have been proposed to extract the relational triplets (e_1, r, e_2) , simultaneously. According to different extraction order, the joint models can be categorized into two paradigms. The first paradigm identifies all entities in the sentence first, then traverses each pair of entities and determines their potential relation. Various models have achieved promising results by exploiting recurrent neural network [16, 17], graph convolutional network [9, 23] and transformer-based structure [7, 25]. Though effective, these models need to examine every possible entity pairs, which inevitably contains a lot of redundant pairs. In the second paradigm, the

head entities are detected first and the corresponding relations and tail entities are extracted later. Bekoulis et al. [2] present the multi-head selection framework to automatically extract multiple entities and relations at once. Huang et al. [12] improve the MHS framework by using NER pretraining and soft label embedding features. Recently, Li et al. [14] cast the task as a question answering problem and identify entities based on a machine reading comprehension model. Different from the first one, the second paradigm is able to extract entities and all the relations at once without enumerating every entity pair each time, which reduces redundant prediction and improves work efficiency.

Positional Representation. Many works design representations to encode positional information for non-recurrent models, which can fall into three categories. The first one designs the position encodings as a deterministic function of position or learned parameters [10, 22]. These encodings are combined with input elements to expose position information to the model. For example, the convolutional neural networks inherently capture the relative positions within each convolutional kernels. The second category is the absolute position representation. The Transformer structure [24] contains neither recurrence nor convolution, in order to inject the positional information to the model, it defines the sine and cosine functions of different frequencies to encode absolute positions. However, such absolute positions cannot model the interaction information between any two input tokens explicitly. Therefore, the third category extends the self-attention mechanism to consider the relative positions between sequential elements [4, 21]. Differently, we propose the relative positions especially for entities to enhance the interactions between them. While we do not consider the relative positions for non-entity tokens to alleviate the unnecessary noise.

Our work is inspired by the multi-head selection framework but enjoys new points as follows. 1) We propose an entity-specific relative position representation to better encode the distance between entities and context tokens. 2) We incorporate the sentence-level information for relation classification to revise the learning of local features. 3) We enhance the original MHS framework with a pre-trained self-attentive encoder. Together these improvements contribute to the extraction performance remarkably.

3 Method

In this section, we briefly present the details of the relative position representation based multi-head selection framework. The concept of multi-head means that any head entity may be relevant to multiple relations and tail entities [2].

Formally, denote \mathcal{E} and \mathcal{R} as the set of pre-defined entity types and relation categories, respectively. Given an input sentence with N tokens $\mathbf{s} = \{s_1, s_2, \dots, s_N\}$, the entity-relation extraction task aims at extracting a set of named entities $\mathbf{e} = \{e_1, e_2, \dots, e_M\}$ with specific types $\mathbf{y} = \{y_1, y_2, \dots, y_M\}$, and predict the relation r_{ij} for each entity pair (e_i, e_j) , where $y_i \in \mathcal{E}$ and $r_{ij} \in \mathcal{R}$. Triplets such as (e_i, r_{ij}, e_j) are formulated as the output, where e_i is the head entity and e_j is the tail entity, e.g., *(John Smith, Live-In, Atlanta)*.

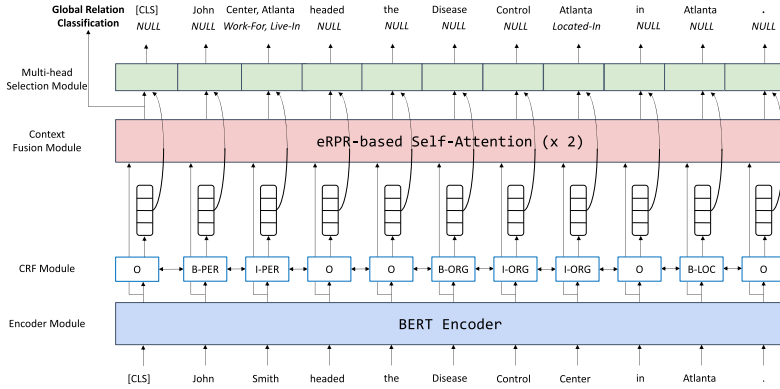

Fig. 2. The overview of the relative position representation based multi-head selection framework. We take a sentence from CoNLL04 dataset as an example. In this sentence, the golden relational triplets are: (*John Smith*, *Live-In*, *Atlanta*), (*John Smith*, *Work-For*, *Disease Control Center*) and (*Disease Control Center*, *Located-In*, *Atlanta*). The *NULL* label denotes a case of no relation.

As illustrated in Fig. 2, our framework consists of four modules as follows: the encoder module, the CRF module, the context fusion module and the multi-head selection module. The token sequence is taken as the input of the framework and is fed into the BERT encoder to capture contextual representations. The CRF module is applied afterward to extract potential head entities (i.e., boundaries and types). Then, the hidden states of BERT and the entity information are fed into the context fusion module to encode the entity position-based features. Finally, a multi-head selection module is employed to simultaneously extract tuples of relation and tail entity for the input token (e.g., (*Work-For*, *Center*) and (*Live-In*, *Atlanta*) for the head entity *Smith*). Additionally, we present the strategy of global relation classification. We will elaborate on each of the modules in the following subsections.

3.1 Encoder Module

The encoder module aims at mapping discrete tokens into distributed semantic representations. Bidirectional Encoder Representations from Transformers (BERT) [5] is a pre-trained language representations built on the bidirectional self-attentive models. It is known for its powerful feature representative ability and recently breaks through the leaderboards of a wide range of natural language processing tasks, such as named entity recognition, word segmentation and question answering. Different from the previous work [2] which uses the BiLSTM as the feature encoder, we use the BERT instead to better represent contextual features.

As illustrated in Fig. 2, given a N -token sentence $\mathbf{s} = \{s_1, s_2, \dots, s_N\}$, a special classification token ([CLS]) is introduced as the first token of the input

sequence as $\{[\text{CLS}], s_1, s_2, \dots, s_N\}$. The sequence is encoded by the multi-layer bidirectional attention structure. The output of the BERT layer is the contextual representation of each token as $\mathbf{h} = \{h_0, h_1, \dots, h_N\}$ where $h_i \in \mathbb{R}^{d_h}$, where d_h denotes the dimension of the hidden state of BERT.

3.2 CRF Module

The conditional random field is a probabilistic method that jointly models interactions between entity labels, which is widely used in named Entity recognition task. Similarly, we employ a linear-chain CRF over the BERT layer to obtain the most possible entity label for each token, e.g., B-PER.

Given the BERT outputs $\mathbf{h} = \{h_0, h_1, \dots, h_N\}$, the corresponding entity label sequence is denoted as $\mathbf{y} = \{y_0, y_1, \dots, y_N\}$. Specifically, we use the BIO (Begin, Inside, Non-Entity) tagging scheme. For example, B-PER denotes the beginning token of a person entity. The probability of using \mathbf{y} as the label prediction for the input context is calculated as

$$p(\mathbf{y}|\mathbf{h}) = \frac{\prod_{i=1}^N \phi_i(y_{i-1}, y_i, \mathbf{h})}{\sum_{\mathbf{y}' \in \mathcal{Y}(\mathbf{h})} \prod_{i=1}^N \phi_i(y'_{i-1}, y'_i, \mathbf{h})}. \quad (1)$$

$\mathcal{Y}(\mathbf{h})$ is the set of all possible label predictions. And $\phi_i(y_{i-1}, y_i, \mathbf{h}) = \exp(\mathbf{W}_{\text{CRF}}^{y_i} h_i + \mathbf{b}_{\text{CRF}}^{y_{i-1} \rightarrow y_i})$, where $\mathbf{W}_{\text{CRF}} \in \mathbb{R}^{d_h \times d_l}$, $\mathbf{b}_{\text{CRF}} \in \mathbb{R}^{d_l \times d_l}$ with d_l denoting the size of the entity label set. $\mathbf{W}_{\text{CRF}}^{y_i}$ is the column corresponding to label y_i , and $\mathbf{b}_{\text{CRF}}^{y_{i-1} \rightarrow y_i}$ is the transition probability from label y_{i-1} to y_i .

During training, the NER loss function is defined as the negative log-likelihood:

$$\mathcal{L}_{\text{NER}} = -\sum_{\mathbf{h}} \log p(\mathbf{y}|\mathbf{h}). \quad (2)$$

During decoding, the most possible label sequence \mathbf{y}^* is the sequence with maximal likelihood of the prediction probability:

$$\mathbf{y}^* = \arg \max_{\mathbf{y} \in \mathcal{Y}(\mathbf{h})} p(\mathbf{y}|\mathbf{h}). \quad (3)$$

The final labels can be efficiently addressed by the Viterbi algorithm [8].

3.3 Context Fusion Module

The context fusion module focuses on injecting the entity-specific relative position representation into the semantic feature of entities to capture the distance information between entities and other context tokens. The self-attention structure in BERT introduces sine and cosine functions of varying frequency to represent the absolute position representation (APR) of tokens. However, such absolute position representation neglects the relative distance information between entities and other tokens, while such distance plays a crucial role in entity-relation prediction. Hence, we introduce an entity-specific relative position representation to efficiently encode the relative distance.

Formally, for the output states of BERT encoder $\mathbf{h} = \{h_0, h_1, \dots, h_N\}$ where $h_i \in \mathbb{R}^{d_h}$, the relative position layer outputs a transformed sequence $\mathbf{p} = \{p_0, p_1, \dots, p_N\}$ where $p_i \in d_p$ with d_p as the hidden dimension of self-attention structure.

Consider two input states h_i and h_j , where h_i denotes an entity and h_j denotes a contextual token, $i, j \in 0, 1, \dots, N$. In order to inject the relative position information into x_i , we define $a_{ij}^K \in d_p, a_{ij}^V \in d_p$ as two different relative distances between h_i and h_j . Suppose that the impacts of tokens beyond a maximum distance on the current token are negligible. Therefore, we clip the relative position within a maximum distance δ and only consider the position information of δ tokens on the left and δ tokens on the right. We define $\omega^K = (\omega_{-\delta}^K, \dots, \omega_{\delta}^K)$ and $\omega^V = (\omega_{-\delta}^V, \dots, \omega_{\delta}^V)$ as two relative position representations, where $\omega_i^K, \omega_i^V \in \mathbb{R}^{d_p}$ are initialized randomly and will be learned during training. Figure 3 illustrates an example of the relative position representations. Then, a_{ij}^K and a_{ij}^V are assigned as:

$$\begin{aligned} a_{ij}^K &= \omega_{\text{clip}(j-i, \delta)}^K \\ a_{ij}^V &= \omega_{\text{clip}(j-i, \delta)}^V \end{aligned} \tag{4}$$

$$\text{clip}(x, \delta) = \max(-\delta, \min(x, \delta)).$$

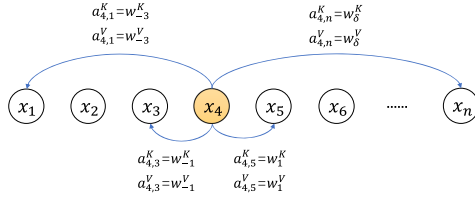

Fig. 3. An example to illustrate the entity relative position representation. x_4 is considered as an entity, we show the eRPR between x_4 and the context tokens within the clipped distance δ . Assuming $3 \leq \delta \leq n - 4$ in this example.

Based on the relative position representations a_{ij}^K, a_{ij}^V , the attention matrix between h_i and h_j is calculated as:

$$\alpha_{ij} = \text{softmax}\left(\frac{(h_i W^Q)(h_j W^K + a_{ij}^K)^T}{\sqrt{d_p}}\right), \tag{5}$$

where $W^Q \in \mathbb{R}^{d_h \times d_p}, W^K \in \mathbb{R}^{d_h \times d_p}$ are parameter matrices for multi-head projections. The attentional output of h_i is the weighted sum of h_j which also consider the relative position:

$$p_i = \sum_{j=1}^n \alpha_{ij} (h_j W^V + a_{ij}^V). \tag{6}$$

Specifically, we only consider the relative position of named entities rather than every tokens in the sentence. So ω^K and ω^V are set as 0 for non-entity tokens. The This entity-only RPR approach comes with the following key advantages: 1) it encodes unique features for entities and thus can better differentiate entities from other plain tokens; 2) it provides entity-specific information and helps the relation and tail entity prediction.

3.4 Multi-head Selection Module

The multi-head selection module aims to predict the possible relations and tail entities simultaneously for each head entity [2]. Given a sequence of entity labels $\mathbf{y} = \{y_0, y_1, \dots, y_N\}$ predicted by the CRF module, we map each label to a distributed label embedding as $\mathbf{l} = \{l_0, l_1, \dots, l_N\}$, $l_i \in \mathbb{R}^{d_l}$, where d_l is the label embedding size. The mapping dictionary is randomly initialized and fine-tuned during training. During training, we use the golden entity labels.

As shown in Fig. 2, the input to the multi-head selection layer are the concatenation of label embedding and the outputs of relative position layer as:

$$z_i = [l_i; p_i], i = 0, 1, \dots, N. \quad (7)$$

For each input state z_i , we compute the score between z_i and z_j given a relation $r_k, r_k \in \mathcal{R}$ as:

$$g(z_i, z_j, r_k) = V^r f(U^r z_j + W^r z_i + b^r), \quad (8)$$

where $V^r \in \mathbb{R}^{d_r}$, $U^r, W^r \in \mathbb{R}^{d_r \times (d_h + d_l)}$, $b^r \in \mathbb{R}^{d_r}$, $f(\cdot)$ is the element-wise RELU function. The most probable tail entity s_j with the relation r_k corresponding to the head entity s_i is predicted as:

$$\Pr(\text{tail} = s_j, \text{relation} = r_k | \text{head} = s_i) = \sigma(g(z_i, z_j, r_k)), \quad (9)$$

where $\sigma(\cdot)$ denotes the sigmoid function.

During training, we optimize the cross-entropy loss \mathcal{L}_{MHS} for the candidate tail entity s_{ij} and relation r_{ij} given the head entity s_i as:

$$\mathcal{L}_{\text{MHS}} = \sum_{i=0}^N \sum_{j=0}^M -\log \Pr(\text{tail} = s_j, \text{relation} = r_j | \text{head} = s_i), \quad (10)$$

where M is the number of golden relations for s_i . During testing, we select the tuple of the relation and tail entity (\hat{r}_k, \hat{s}_j) with a score exceeding the confidence threshold η . In this way, multiple tail entities and relations for the head entity s_i can be predicted simultaneously.

3.5 Global Relation Classification

Generally, detecting the relation between entities needs to consider the theme of the sentence. The previous work only use the local context information for relation and entity prediction, which may lead to the deviation of global semantics.

We introduce the global relation classification strategy to guide the training of local semantic features. As illustrated in Fig. 2, the first output of the relative position layer corresponding to the hidden state of [CLS] token p_0 , which can be considered as the aggregate representation of the sentence. Therefore, we use the [CLS] token to predict the relations relevant to the whole sentence \mathbf{s} as:

$$\Pr(\text{relation} = \mathbf{r}|\mathbf{s}) = \sigma(W^g p_0 + b^g), \quad (11)$$

where $\mathbf{r} \subseteq \mathcal{R}$, $W^g \in \mathbb{R}^{d_h \times |\mathcal{R}|}$, $b^g \in \mathbb{R}^{|\mathcal{R}|}$, $\sigma(\cdot)$ is the sigmoid function. During training, we minimize the binary cross-entropy loss for the global classification as:

$$\mathcal{L}_{\text{GRC}} = \sum_{i=0}^T \Pr(\text{relation} = \mathbf{r}|\mathbf{s}), \quad (12)$$

where T denotes the number of golden relations in the sentence.

3.6 Joint Training

To train the model jointly, we optimize the final combined objective function as:

$$\mathcal{L} = \mathcal{L}_{\text{NER}} + \lambda \mathcal{L}_{\text{GRC}} + \mathcal{L}_{\text{MHS}}, \quad (13)$$

where \mathcal{L}_{NER} , \mathcal{L}_{GRC} , and \mathcal{L}_{MHS} denote the loss function for head entity recognition, global relation classification and multi-head selection, respectively (Eq. 2, 12, 10), $\lambda \in [0, 1]$ is the weight controlling the trade-off of the global relation classification. \mathcal{L} is averaged over samples for each batch.

4 Experiment

In this section, we conduct extensive experiments to verify the effectiveness of our framework, and make detailed analyses to show its advantages.

4.1 Dataset

We conduct evaluation on two widely-used benchmarks for entity and relation extraction: CoNLL04 and ACE05.

CoNLL04 [20] defines 4 entity types as Location (LOC), Organization (ORG), Person (PER) and Other and 5 relation categories as Located-In, OrgBased-In, Live-In, Kill and Work-For. It consists of news articles from the Wall Street Journal and Associated Press. We use the data split by Gupta et al. [11] (910 instances for training, 243 for validation and 288 for testing).

ACE05 [6] provides 7 entity types: Location (LOC), Organization (ORG), Person (PER), Geopolitical Entity (GPE), Vehicle (VEH), Facility (FAC), Weapon (WEA) and 6 relation types: ORG-AFF, PER-SOC, ART, PART-WHOLE, GEN-AFF, PHYS. It contains documents from different domains such as newswire and online forums. We adopt the same data splits as the previous work [17] (351 documents for training, 80 for validation and 80 for testing).

4.2 Implemental Details

Following previous works, we use the standard precision (P), recall (R), and micro-F1 score (F1) as the evaluation metrics. A relation is correct if the arguments of triplet (e_1, r, e_2) are correct. Other experimental settings are as follows. We initialize the BERT encoder layer using the pre-trained BERT-Base-Cased checkpoint¹ which has 12 layers, a hidden size of 768. We use Adam optimizer with an initial learning rate of 5×10^{-5} . During training, we do warm-up startup first and employ a linearly decrease with 0.05 as the decay rate. For the model structure, we adopt 2-layer eRPR-based self-attention after the BERT encoder layer. The self-attention layer has an identical structure as the layer in BERT. The relative position representations ω^K, ω^V are initialized randomly with a uniform distribution. The maximum relative distance is set as $\delta = 4$. The GRC loss weight is set as $\lambda = 1$. The size of entity label embedding is set as $d_l = 50$. The threshold for multi-head selection $\eta = 0.5$.

Specifically, we use both the *relaxed* and the *strict* evaluation settings for comparison. In the *relaxed* setting, a multi-token entity is correct if at least one of its comprising token types is correct; a relation is correct if the two argument entities are correct and the relation type is correct. In the *strict* setting, we consider an entity is correct if the entity type and the boundaries are both correct; a relation is correct if the relation type and the argument entities are both correct.

4.3 Results and Analyses

Comparison Baseline. As shown in Table 1, we list the following baselines for comparison. Gupta et al. [11] propose a table-filling based method that relies on hand-crafted features and external NLP tools. Adel and Schütze [1] use a global normalized convolutional neural networks to extract entities and relations. Miwa and Bansal [1] adopt a BiLSTM to extract entities and a Tree-LSTM to model the dependency relations between entities. Bekoulis et al. [2] propose the multi-head selection structure, which adopts BiLSTM as the feature encoder and uses CRF for entity recognition and can extract the relational triplet simultaneously. The results on CoNLL04 and ACE05 are directly copied from the published paper.

Main Results. Table 1 presents the performance comparisons on CoNLL04 and ACE05 datasets. eRPR MHS is the proposed full model, which uses the BERT at encoder module, and follows by two eRPR self-attention layers and adopts the GRC strategy. As we can see, our eRPR MHS overwhelmingly outperforms all the baseline models in terms of all three evaluation metrics on the two datasets. by a large margin for both entity and relation extraction. Especially, comparing with the model by Bekoulis et al. [2], our model achieves significant boosts by 2.40% and 1.90% for relation F1 on CoNLL04 and ACE05, respectively. These

¹ BERT checkpoints are available at <https://github.com/google-research/bert>.

Table 1. Performance comparison with baselines on CoNLL04 and ACE05. eRPR denotes models adopt the self-attention with entity-specific relative position representation at the context fusion module. The ✓ and ✗ marks stand for whether or not the model builds on hand-crafted features or NLP tools. eRPR MHS is the proposed full model.

Model	Pre-calculated features	Evaluation	Entity			Relation		
			P	R	F1	P	R	F1
CoNLL04								
Gupta et al. [11]	✓	<i>relaxed</i>	92.50	92.10	92.40	78.50	63.00	69.90
Gupta et al. [11]	✗	<i>relaxed</i>	88.50	88.90	88.80	64.60	53.10	58.30
Adel and Schütze [1]	✗	<i>relaxed</i>	-	-	82.10	-	-	62.50
Bekoulis et al. [2]	✗	<i>relaxed</i>	93.41	93.15	93.26	72.99	63.37	67.01
eRPR MHS	✗	<i>relaxed</i>	94.32	93.81	94.06	73.85	64.41	68.81
Miwa and Sasaki [19]	✓	<i>strict</i>	81.20	80.20	80.70	76.00	50.90	61.00
Bekoulis et al. [2]	✗	<i>strict</i>	83.75	84.06	83.90	63.75	60.43	62.04
eRPR MHS	✗	<i>strict</i>	86.85	85.62	86.23	64.20	64.69	64.44
ACE05								
Miwa and Bansal [17]	✓	<i>strict</i>	80.80	82.90	81.80	48.70	48.10	48.40
Katihar and Cardie [13]	✗	<i>strict</i>	81.20	78.10	79.60	46.40	45.53	45.70
eRPR MHS	✗	<i>strict</i>	86.26	84.66	85.45	60.60	60.84	60.72

results show that, with our enhanced components, i.e., the eRPR layers, the global relation classification and the BERT encoder, the model performance can be significantly improved. Such improvements highlight the effectiveness of our proposed framework.

Ablation Study. As shown in Table 2, we list variant models (Model 1–5) for each component in our framework. Model 1 stands for the original MHS framework proposed by Bekoulis et al. [2]. By comparison, we come to the following conclusions. 1) Replacing the BiLSTM with pre-trained BERT can improve the performance obviously (Model 2 v.s. Model 1). 2) Adding the context fusion module after the encoder module can enhance the semantic representation, leading to higher results (Model 3 v.s. Model 2). 3) Comparing Model 4 with the above variations, incorporating eRPR into the self-attention structure can significantly increase the precision of models and thus contribute to better overall F1 scores. For example, it increases the relation F1 from 63.96% to 64.21% on CoNLL04. We attribute it to that, the eRPR injects distance information into entity features, which can provide useful information to the multi-head selection. 4) Comparing Model 5 and Model 4, the GRC strategy can further improve model performance. Therefore, global information is instructive for learning local features. Finally, combining all these components, we achieve significant improvements over the original MHS.

Table 2. Ablation study on CoNLL04 and ACE05. APR denotes models adopt the general self-attention with absolute position representation at the context fusion module. eRPR denotes models adopt the self-attention with entity-specific relative position representation at the context fusion module. The ✓mark refers to the model including the global relation classification. We use the *strict* evaluation setting here.

Model	Encoder	Context fusion	GRC	Entity			Relation		
				P	R	F1	P	R	F1
CoNLL04									
1	BiLSTM	-	-	83.75	84.06	83.90	63.75	60.43	62.04
2	BERT	-	-	85.75	86.28	86.00	65.15	62.56	63.83
3	BERT	APR Layer ×2	-	86.32	85.68	86.00	64.53	63.40	63.96
4	BERT	eRPR Layer ×2	-	86.75	85.56	86.15	63.93	64.50	64.21
5	BERT	APR Layer ×2	✓	86.78	85.66	86.22	64.18	64.30	64.24
6	BERT	eRPR Layer ×2	✓	86.85	85.62	86.23	64.20	64.69	64.44
ACE05									
1	BiLSTM	-	-	84.88	84.10	84.49	57.40	60.32	58.82
2	BERT	-	-	85.70	84.25	84.96	59.92	60.06	59.99
3	BERT	APR Layer ×2	-	86.18	84.55	85.36	60.23	60.82	60.52
4	BERT	eRPR Layer ×2	-	86.24	84.60	85.41	60.57	60.76	60.66
5	BERT	APR Layer ×2	✓	86.22	84.57	85.39	60.46	60.76	60.61
6	BERT	eRPR Layer ×2	✓	86.26	84.66	85.45	60.60	60.84	60.72

4.4 Effect of the Maximum Relative Distance

In this subsection, we evaluate the effect of varying the maximum relative distance δ . Following previous studies [21], we conduct experiments on CoNLL04 with different maximum relative distance δ , increases exponentially from 0 to 64. Figure 4a shows the experimental results. We observe that when $\delta = 8$, the entity F1 has the best result, and when $\delta = 4$, the relation F1 has the best result. Meanwhile, the larger value of δ (i.e., $\delta = 64$) is meaningless for both entity and relation extraction, which verifies that the impacts of tokens beyond a maximum distance can be negligible. Therefore, to ensure a better performance for relation extraction, we set $\delta = 4$ for all the experiments.

4.5 Effect of the GRC Loss Weight

In this subsection, we evaluate the effect of different GRC loss weight λ to the model performance. We keep the maximum relative distance δ as 4 and conduct the experiments on the CoNLL04 dataset with λ from 0 to 1 at the interval of 0.2. As shown in Fig. 4a, the setting with $\lambda = 0$ denotes the GRC is not used in

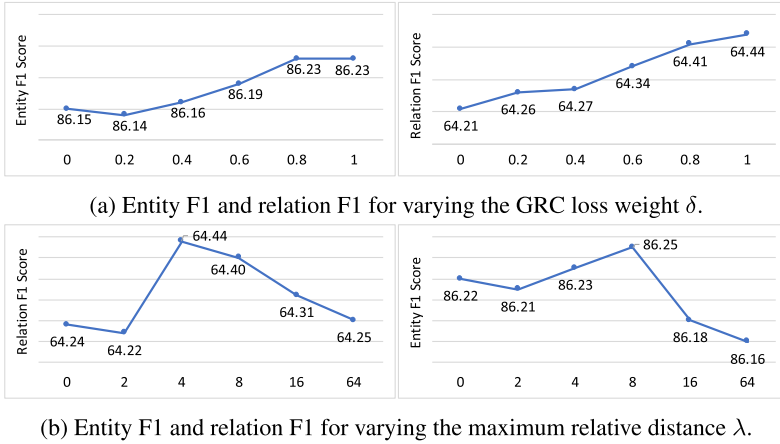

Fig. 4. Results for varying the GRC loss weight δ and the maximum relative distance λ .

the framework and its performance is much lower than settings with larger λ . In addition, with the growth of λ , both entity and relation F1 scores are increased continuously. As such, we keep $\lambda = 1$ for all the above experiments. These comparison results further demonstrate the effectiveness of GRC. Therefore, the sentence-level information can be utilized fruitfully for multi-head selection and helps improve the overall performance.

5 Conclusion

In this paper, we propose a relative position representation based multi-head selection framework for joint entity and relation extraction. Different with the existing multi-head selection method, we introduce the relative position representation to capture the distance information of entities. We then propose a global relation classification to guide the learning of local features. Additionally, BERT is incorporated in the framework for semantic representation. Experimental results on CoNLL04 and ACE05 datasets show that our framework significantly outperforms all the baseline models for both entity and relation extraction.

Acknowledgements. This work was supported in part by the National Natural Science Foundation of China (Grant Nos. U1636211, 61672081,61370126), the Beijing Advanced Innovation Center for Imaging Technology (Grant No. BAICIT-2016001), and the Fund of the State Key Laboratory of Software Development Environment (Grant No. SKLSDE-2019ZX-17).

References

1. Adel, H., Schütze, H.: Global normalization of convolutional neural networks for joint entity and relation classification. In: Proceedings of the 2017 Conference on Empirical Methods in Natural Language Processing, pp. 1723–1729 (2017)
2. Bekoulis, G., Deleu, J., Demeester, T., Develder, C.: Joint entity recognition and relation extraction as a multi-head selection problem. *Expert Syst. Appl.* **114**, 34–45 (2018)
3. Chan, Y.S., Roth, D.: Exploiting syntactico-semantic structures for relation extraction. In: Proceedings of the 49th Annual Meeting of the Association for Computational Linguistics: Human Language Technologies, pp. 551–560 (2011)
4. Dai, Z., Yang, Z., Yang, Y., Carbonell, J.G., Le, Q., Salakhutdinov, R.: Transformer-xl: attentive language models beyond a fixed-length context. In: Proceedings of the 57th Annual Meeting of the Association for Computational Linguistics, pp. 2978–2988 (2019)
5. Devlin, J., Chang, M.W., Lee, K., Toutanova, K.: Bert: pre-training of deep bidirectional transformers for language understanding. In: Proceedings of the 2019 Conference of the North American Chapter of the Association for Computational Linguistics: Human Language Technologies, vol. 1 (Long and Short Papers), pp. 4171–4186 (2019)
6. Doddington, G.R., Mitchell, A., Przybocki, M.A., Ramshaw, L.A., Strassel, S.M., Weischedel, R.M.: The automatic content extraction (ACE) program-tasks, data, and evaluation. In: LREC, pp. 837–840 (2004)
7. Eberts, M., Ulges, A.: Span-based joint entity and relation extraction with transformer pre-training. arXiv preprint [arXiv:1909.07755](https://arxiv.org/abs/1909.07755) (2019)
8. Forney, G.D.: The viterbi algorithm. In: Proceedings of the IEEE, pp. 268–278 (1973)
9. Fu, T.J., Li, P.H., Ma, W.Y.: Graphrel: modeling text as relational graphs for joint entity and relation extraction. In: Proceedings of the 57th Annual Meeting of the Association for Computational Linguistics, pp. 1409–1418 (2019)
10. Gehring, J., Auli, M., Grangier, D., Yarats, D., Dauphin, Y.N.: Convolutional sequence to sequence learning. In: Proceedings of the 34th International Conference on Machine Learning, vol. 70, pp. 1243–1252 (2017)
11. Gupta, P., Schütze, H., Andrassy, B.: Table filling multi-task recurrent neural network for joint entity and relation extraction. In: Proceedings of COLING 2016, the 26th International Conference on Computational Linguistics: Technical Papers, pp. 2537–2547 (2016)
12. Huang, W., Cheng, X., Wang, T., Chu, W.: BERT-based multi-head selection for joint entity-relation extraction. In: Tang, J., Kan, M.-Y., Zhao, D., Li, S., Zan, H. (eds.) NLPCC 2019. LNCS (LNAI), vol. 11839, pp. 713–723. Springer, Cham (2019). https://doi.org/10.1007/978-3-030-32236-6_65
13. Katiyar, A., Cardie, C.: Going out on a limb: joint extraction of entity mentions and relations without dependency trees. In: Proceedings of the 55th Annual Meeting of the Association for Computational Linguistics (vol. 1: Long Papers), pp. 917–928 (2017)
14. Li, X., et al.: Entity-relation extraction as multi-turn question answering. In: Proceedings of the 57th Annual Meeting of the Association for Computational Linguistics, pp. 1340–1350 (2019)

15. Lin, Y., Shen, S., Liu, Z., Luan, H., Sun, M.: Neural relation extraction with selective attention over instances. In: Proceedings of the 54th Annual Meeting of the Association for Computational Linguistics (vol. 1: Long Papers), pp. 2124–2133 (2016)
16. Luan, Y., Wadden, D., He, L., Shah, A., Ostendorf, M., Hajishirzi, H.: A general framework for information extraction using dynamic span graphs. In: Proceedings of the 2019 Conference of the North American Chapter of the Association for Computational Linguistics: Human Language Technologies, vol. 1 (Long and Short Papers), pp. 3036–3046 (2019)
17. Miwa, M., Bansal, M.: End-to-end relation extraction using LSTMS on sequences and tree structures. In: Proceedings of the 54th Annual Meeting of the Association for Computational Linguistics (vol. 1: Long Papers), pp. 1105–1116 (2016)
18. Miwa, M., Sætne, R., Miyao, Y., Tsujii, J.: A rich feature vector for protein-protein interaction extraction from multiple corpora. In: Proceedings of the 2009 Conference on Empirical Methods in Natural Language Processing, pp. 121–130 (2009)
19. Miwa, M., Sasaki, Y.: Modeling joint entity and relation extraction with table representation. In: Proceedings of the 2014 Conference on Empirical Methods in Natural Language Processing, pp. 1858–1869 (2014)
20. Roth, D., Yih, W.T.: A linear programming formulation for global inference in natural language tasks. Technical report, Illinois Univ At Urbana-Champaign Department of Computer Science (2004)
21. Shaw, P., Uszkoreit, J., Vaswani, A.: Self-attention with relative position representations. In: Proceedings of the 2018 Conference of the North American Chapter of the Association for Computational Linguistics: Human Language Technologies, vol. 2 (Short Papers), pp. 464–468 (2018)
22. Sukhbaatar, S., Weston, J., Fergus, R., et al.: End-to-end memory networks. In: Advances in Neural Information Processing Systems, pp. 2440–2448 (2015)
23. Sun, C., et al.: Joint type inference on entities and relations via graph convolutional networks. In: Proceedings of the 57th Annual Meeting of the Association for Computational Linguistics, pp. 1361–1370 (2019)
24. Vaswani, A., et al.: Attention is all you need. In: Advances in Neural Information Processing Systems, pp. 5998–6008 (2017)
25. Wang, H., et al.: Extracting multiple-relations in one-pass with pre-trained transformers. In: Proceedings of the 57th Annual Meeting of the Association for Computational Linguistics, pp. 1371–1377 (2019)
26. Zhao, T., Yan, Z., Cao, Y., Li, Z.: Asking effective and diverse questions: a machine reading comprehension based framework for joint entity-relation extraction. In: Proceedings of the Twenty-Ninth International Joint Conference on Artificial Intelligence, pp. 3948–3954 (2020)