



# Psychometric Evaluation of Stress in 17,414 Critical Care Unit Nurses: Effects of Age, Gender, and Working Conditions

Mohammad Asghari Jafarabadi,  
Amir Vahedian-Azimi, Farshid Rahimibashar,  
Paul C. Guest, Leila Karimi,  
and Amirhossein Sahebkar

## Abstract

Recent events regarding the COVID-19 pandemic have demonstrated the importance of healthcare workers around the world and the stressful working conditions that are often associated with their profession. The severity of stress can be influenced by a number of factors such as age, seniority gender, family status, and position in the wards. Thus, it is important to monitor signs of stress and other psychiatric symptoms in order to understand the mediating factors and guide appropriate interventions. Here, we describe a cross-

sectional study of 17,414 nurses from 31 Iranian cities carried out from 2011 to 2015, using a 22-item tool of work stressors. The tool examined interactive, managerial, and situational domains and the main objective was to identify the main background variables associated with the stress of nurses in critical care settings.

## Keywords

Psychometric · Stress measure · Nurse · Age · Gender · Iran

M. A. Jafarabadi  
Road Traffic Injury Research Center, Tabriz  
University of Medical Sciences, Tabriz, Iran

Department of Biostatistics and Epidemiology,  
Faculty of Medicine, Zanjan University of Medical  
Sciences, Zanjan, Iran

A. Vahedian-Azimi (✉)  
Trauma Research Center, Nursing Faculty,  
Baqiyatallah University of Medical Sciences,  
Tehran, Iran

F. Rahimibashar  
Department of Anesthesiology and Critical Care,  
School of Medicine, Hamadan University of Medical  
Sciences, Hamadan, Iran

P. C. Guest  
Laboratory of Neuroproteomics, Department of  
Biochemistry and Tissue Biology, Institute of Biology,  
University of Campinas (UNICAMP), Campinas, Brazil

L. Karimi  
Behavioral Sciences Research Center, Nursing  
Faculty, Baqiyatallah University of Medical Sciences,  
Tehran, Iran

A. Sahebkar (✉)  
Biotechnology Research Center, Pharmaceutical  
Technology Institute, Mashhad University of Medical  
Sciences, Mashhad, Iran

Neurogenic Inflammation Research Center, Mashhad  
University of Medical Sciences, Mashhad, Iran

Polish Mother's Memorial Hospital Research  
Institute (PMMHRI), Lodz, Poland

## 14.1 Introduction

Nursing is a job with a high level of stress, especially in critical care units (CCUs), including intensive care units [1, 2]. Occupational stress in the healthcare area is associated with specific situations, such as problems with co-workers, conflicts, double shifts, pressure from superiors according to the individual's perception, changes in occupation, and coping with emergency situations. Among the healthcare professionals, nurses often suffer from the consequences of occupational stress, showing problems such as dissatisfaction with work, burnout syndrome, and absenteeism [2–4].

This situation has come more into the public eye with the COVID-19 outbreak, which has now spread to more than 200 countries and territories worldwide [5]. Healthcare workers who are directly involved in the diagnosis, treatment, and care of patients with this deadly virus are at high risk of both physical and mental harm. The widespread media coverage and increasing number of cases and deaths, along with the overwhelming workload, inadequate supply of personal protective equipment, and current lack of effective treatments, can contribute to the mental health effects on these key workers. Previous studies on the severe acute respiratory syndrome (SARS) outbreak in 2002–2003 reported detrimental psychological effects in healthcare workers on the front lines [6–10]. Similar effects on healthcare workers were reported during and in the aftermath of the Middle East respiratory syndrome (MERS) outbreak which began in 2012 [11–14].

One factor that can affect stress and anxiety levels is age. Epidemiologic surveys of the general population have found that anxiety disorders occur more frequently in younger adults compared with older individuals [15, 16]. Conversely, depression occurs more often in older adults compared to the younger population [17, 18]. Working in CCUs has also been positively associated with greater stress levels. The crucial responsibilities of nurses in critical and intensive care include the operation of sophisticated technologies and fast decision-making, which can be affected by excessive workload, different man-

agement styles and skills, professional disagreements, and the emotions involved in caring [19–22]. Such characteristics and conditions can lead to both emotional and mental stress for nurses working in CCUs, and this can lead to an inability to cope and cessation of work [1]. Therefore, it is important to develop and apply tools to aid in assessing the stress levels of CCU nurses.

To understand the stressors and the means of their resolution, several studies have been conducted. Although different tools have been developed for this purpose, a major point that has been omitted in most of these is social and environmental differences in different hospitals and different social and cultural environments [19–21]. An instrument to adequately measure stress and which incorporates these factors is of prime interest in public health research.

In order to investigate the stressors of nurses in special sectors in Iran, we carried out a comprehensive study across Iran to assess the impact of culture, facilities, access to services, and types of patients in relation to nurses' stress levels. We used a partial least square (PLS) approach for psychometric evaluation of a stress scale among 17,414 nurses across 31 Iranian cities. Our main objective was to provide a system for assessing the mental health of nurses and other healthcare workers during the continuing COVID-19 crisis and future pandemics.

---

## 14.2 Methods

### 14.2.1 Design, Setting, and Procedures

The details on methodology of this study have been reported elsewhere [1]. Briefly, a cross-sectional study was conducted in 31 Iranian cities during the period between January 1, 2011, and December 1, 2015. A multistage cluster random sampling scheme was used to collect all data. In a second stage, ten hospitals were selected randomly as clusters in each city. In the final stage, 5 hospitals with more than 100 working nurses in CCUs were selected through a cluster random

sampling scheme. In 5 of the cities, the hospitals had fewer than 100 critical care nurses, in which case all 10 hospitals were selected. The participants who were (1) aged >18 years, (2) registered nurses, (3) working in the intensive care unit (ICU), and (4) willing to participate in the study were included and those who were not available to complete the questionnaire were excluded. The eligible and consenting nurses completed the two-part survey including the demographic and work stressor variables, which typically took place over 10–15 min.

### 14.2.2 Ethical Considerations

The study was approved by the institutional review board at Baqiyatallah University of Medical Sciences (Tehran, Iran). The ethical issues were reviewed and approved by ethical committee of each hospital. Since the research presented no more than minimal risk of harm to participants and involved no procedures for which written consent is normally required outside the research context, the principle of implied consent was adopted. This meant that by completion of the survey instrument, the participant demonstrated their willful consent to participate after the purpose of the study was explained to them. The participants were free to take part, to refuse, or to withdraw from the study at any time, and confidentiality of personal data was guaranteed to them. Although Iranian medical ethics laws (<http://mehr.tums.ac.ir/Codes.aspx>) do not specifically address this topic, it is in accordance with other international ethics codes and laws including the US Federal Code of Regulations (45 CFR 46.117c). All parts of the study were reviewed and reported according to the Strengthening the Reporting of Observational Studies in Epidemiology statement [23].

### 14.2.3 Sample Size

The sample size determination process was reported elsewhere [1, 22], considering 95% confidence level and 90% power and taking into

account the main outcome of relations between background variables and stress. A total of 17,414 nurses took part in the study. This sample size was higher than the minimal requirement sample size to conduct PLS confirmatory factor analysis (PLS-CFA) that assumes ten times the largest number of structural paths directed at a particular construct in the structural model [24].

### 14.2.4 Measurements

The measurements used in this study consisted of demographic/background variables and work stressor items. In the first part, the demographic/background variables involved age, gender, marital status, number of children, body mass index (BMI), education level, years of critical care nursing experience, shift schedule, frequency of working holidays, and ratio of nurses to patients and hospital. A 22-item tool of work stressors was administered (Table 14.1) as reported previously [1, 22]. This list was

**Table 14.1** Stressful situations scale with 22 items

1. Dealing with patient's pain and suffering
2. Family presence
3. Heavy workload
4. Relatives' reaction
5. Time pressure
6. Communicating bad news
7. The necessity of having continual readiness for emergency procedures
8. Death & dying
9. Staff shortage
10. Non-nursing tasks
11. Patients' reactions
12. Physician not available
13. Instability of patient's clinical condition
14. Lack of resources
15. Working extra hours
16. Physicians' demands
17. Decision-making
18. Unpleasant tasks
19. Shift rotation
20. Poor cooperation in dialysis, CCU, and ICU
21. Poor cooperation & communication in other depts.
22. Disproportionate between salary and job hardness

CCU critical care unit, ICU intensive care unit

extracted in nursing working environments in CCU wards, categorized and prioritized qualitatively and quantitatively. The items were quantitatively prioritized by three panels of experts with the output from each step used as the input for the next step, to arrive at a final list. A qualitative analysis consisted of unstructured interviews administered utilizing content analysis, and the categories of nursing job stressors were extracted. Finally, the items in the quantitative and qualitative parts were merged, and the scale was derived and validated in a 3-classic-round Delphi technique [25].

The expert panel consisted of five psychiatric nurses, one psychologist, one psychiatrist, five ICU nurses, five CCU nurses, five dialysis unit nurses, three intensivists, three cardiologists, three nephrologists, and five ICU administrators. After the sessions, the Kendall's  $k$  agreement coefficient test was 0.89 which indicated a good agreement [26].

The final scale consisted of three subscales: (1) interactive and communicative (items 1, 2, 4, 11, 20, and 21), (2) managerial and administrative (items 3, 9, 10, 12, 14, 15, 16, 19, and 22), and (3) exclusive and situational (items 5, 6, 7, 8, 13, 17, and 18). Items assessing work stressors were rated on a five-point Likert-type scale ranging from "1: causes me no stress" to "5: causes me extreme stress." The total score of the scale was calculated by sum over the items and the scores on subscales were calculated by sum over the items on that subscale. The total scores ranged from 22 to 110 with higher scores indicating higher stress.

The content validity of the scale was assessed both quantitatively and qualitatively by the expert panel. In the quantitative part, the content validity index (CVI) and content validity ratio (CVR) were calculated based on a designed form consisting of questions relating to the relatedness, simplicity, and clarity using a four-point ranking scale. In the qualitative part, the experts had some recommendations on modification of some words, sentences, and/or structure of the items which were implemented and the scale was finalized accordingly.

Based on the results of a pilot study [1, 22], the threshold for significant stress was set at 67, with higher values being indicative of the highest stress levels. This cutoff was derived using both qualitative and quantitative assessments, with the latter conducted by receiver operating characteristic curve analysis (results not shown).

#### 14.2.5 Statistical Analyses

Statistical analysis was conducted using STATA (ver.13) (StataCorp LLC, College Station, TX, USA) and SmartPLS (ver. 3.2.8) (<https://www.smartpls.com>) software and  $P$ -values  $<0.05$  were considered as significant in all analyses. Normality of the numeric variables was checked by the Kolmogorov-Smirnov test and data were expressed as mean (SD) and median (min-max) for the numeric normal and non-normal variables, respectively, and frequency (%) for categorical variables.

PLS-CFA was used to assess the construct validity of the scale, by PLS structural equation modeling (PLS-SEM). A second order PLS-CFA was fitted to the data. In the first step of the model, three subscales of interactive, managerial, and situational stress comprised the items, and, in the second step, the stress scale comprised the three subscales. PLS-SEM lacks a fitting index of the chi-square-based model to assess the theoretical model adjustment with collected data, unlike *covariance*-based SEM (CV-SEM), which depends on the *predictive nature* of PLS. Therefore, fitting the indices in this approach was associated with assessment of *model adequacy in prediction of dependent variables* [27]. To modify this and reaching an adequate model, all items with loadings less than 0.5 were removed from the model one at a time, and the indices assessed. This process continued until the model achieved a suitable reliability and validity.

To test the reliability of reflective measurement model, we assessed three indices: Cronbach's alpha, composite reliability or Dillon-Goldstein's  $\rho$ , and communality. For

Cronbach's alpha, values higher than 0.7 indicated acceptable reliability, and alpha values between 0.6 and 0.7 were acceptable for exploratory models. Also, composite reliability was utilized to evaluate internal reliability of constructs, wherein reliability was not calculated absolutely but in regard to their correlation with each other. Composite reliability values higher than 0.7 indicated suitable internal consistency of the measurement model and values lower than 0.6 showed lack of reliability.

The reflective measurement model was homogeneous if the absolute value of a loading factor corresponding with a construct in the model was at least 0.7, equal to a communality of 0.5 ( $0.7^2=0.49$ ) [28]. To assess the validity of the reflective measurement model, we checked both convergent validity and discriminant validity. For convergent validity, average variance extracted (AVE) was used which indicates shared average variance between every construct with its indices. This shows the correlation of an index with itself with higher correlation reflecting a better fit. Discriminant validity measures the ability of the reflective measurement model for discrimination in the model [24]. AVE values higher than 0.5 showed acceptable convergent validity and discriminant validity was acceptable when the AVE for every construct was more than the shared variance between that construct and others (i.e., the square of the correlation coefficient between constructs) [29, 30].

Using *goodness of fit (GOF)* criteria, we assessed the general fit of the model. GOF is the square root of multiplying the "average coefficient of determination" by the "average communality index of construct" [31]. Wetzels et al. introduced the values of 0.01, 0.25, and 0.36 for weak, middle, and strong *GOF* of a general model [32]. The R squared values indicate the coefficient of determination, with values of 0.19, 0.33, and 0.67 indicating weak, middle, and good prediction ability [33].

Next, the relationship between total stress scores and the PLS-indicated components with background variables was modeled using gen-

eralized estimating equations (GEE). The model was built in a multivariate manner and included the explanatory variables of gender, education level, marital status, working shift, patient-to-nurse ratio, collaboration, supportive supervisor, working in holiday, ICU type, ICU system, age (years), clinical experience (years), BMI ( $\text{kg}/\text{m}^2$ ), children (number), and ICU beds (number). The compound symmetry covariance structure took into account the structure introduced by the 31 cities. The categorical variables were entered in the model as indicators. Regression coefficients and their standard error were estimated.

---

## 14.3 Results

From 21,767 administered surveys, 17,414 cases returned valid surveys with a confidence interval (CI) = 79.5–80.5%. The surveys were completed in ICUs ( $n = 370$ ), coronary care units ( $n = 240$ ), and dialysis units ( $n = 180$ ) at 180 educational and private hospitals. The details on demographic characteristics of the participants are provided elsewhere [1]. Briefly, the mean age of participants was 29 years ( $SD = 5.4$ ; range = 21–43 years), 31% of the participants were male, and the ratios of patients to nurses were 3, 2, and 1 for 5.4%, 10.2%, and 84.4%, respectively. The mean job experience of the participants was 16.5 years ( $SD = 6.4$ ; range = 4–27 years). The mean stress score was 69.2 out of 100 points ( $SD = 3.2$ ; range = 62–84). Approximately 71% (95% CI = 70.3–71.7%) exceed the cutoff score of 67 for significant stress.

### 14.3.1 Content Validity

Based on the opinion of 36 experts in the field, an impact score  $> 1.5$ , CVI values  $> 0.75$ , and CVR  $> 0.42$  confirmed face validity and content validity of the items in this instrument (Table 14.2). For the qualitative analysis, required modifications were made according to the integrated experts' opinions.

**Table 14.2** Face and content validity of the instrument

	Value
Face validity (impact score)	2.09–4.67
Content validity (CVR)	0.42–0.68
Content validity (CVI)	0.63–0.93

### 14.3.2 Construct Validity

A second-order PLS-SEM was fitted. In the first step, three subscales of interactive, managerial, and situational stress comprised the items, and in the second step, the stress scale comprised the subscales. The initial model (Fig. 14.1) was modified by iteratively removing each single item (with  $<0.5$  lowest loadings). In the modified model (Fig. 14.2), the reliability and validity of the model and the adequacy were assessed. The model showed adequate fit ( $R^2 = 0.77, 0.83, \text{ and } 0.63$  for interactive, managerial, and situational subscales) indicating middle to good predictive ability of the subscales. This suggested a generally suitable fit of the CFA-PLS model ( $GOF = 0.642 > 0.36$ ). In addition, path coefficients relating items to the subscales and those relating subscales to the stressful total scale were all significant ( $P < 0.05$ ).

### 14.3.3 Reliability

For stability reliability, composite reliability, and internal consistency reliability, indices with values  $>0.7$  confirmed the reliability of the instrument (Table 14.3). Cronbach's alphas for all subscales were in the range of 0.63–0.79, indicating suitable internal consistency reliability of the indices. For the total scale, the Cronbach's alpha was 0.85, indicating a good level of internal consistency of the stress scale (Table 14.3). The values of composite reliability for all constructs were also  $>0.7$ , which indicated suitable internal consistency of the constructs (Table 14.3).

### 14.3.4 Convergent Validity

The AVE value for all subscales was higher than 0.5, indicating suitable convergent validity (Table 14.3).

### 14.3.5 Discriminate Validity (the Fornell-Larcker Criterion)

Application of the Fornell and Larcker method showed that the model had acceptable divergent validity as the values of the principle diameter (i.e., the correlation among the subscales by itself) were higher than the correlations between a variable and other variables (Table 14.4), indicating the discriminate validity of the instrument [30].

### 14.3.6 Relationship Between Stress Components and Background Variables

The results of GEE on assessment of the relationship between total stress scores and PLS-indicated components with background variables are given in Table 14.5. The results were significantly higher for males, higher education levels, and separated or widowed individuals. Also the finding indicated significantly higher interactive, managerial, and total stress in rotation working shift and significantly lower scores of situational stress in rotation working shifts. High-level collaboration was associated with significantly lower stress scores, and supportive supervisor was associated with significantly lower interactive and total stress scores. Working in holidays was associated with significantly higher managerial stress. Age, clinical experience years, and number of children had an inverse relationship with stress.



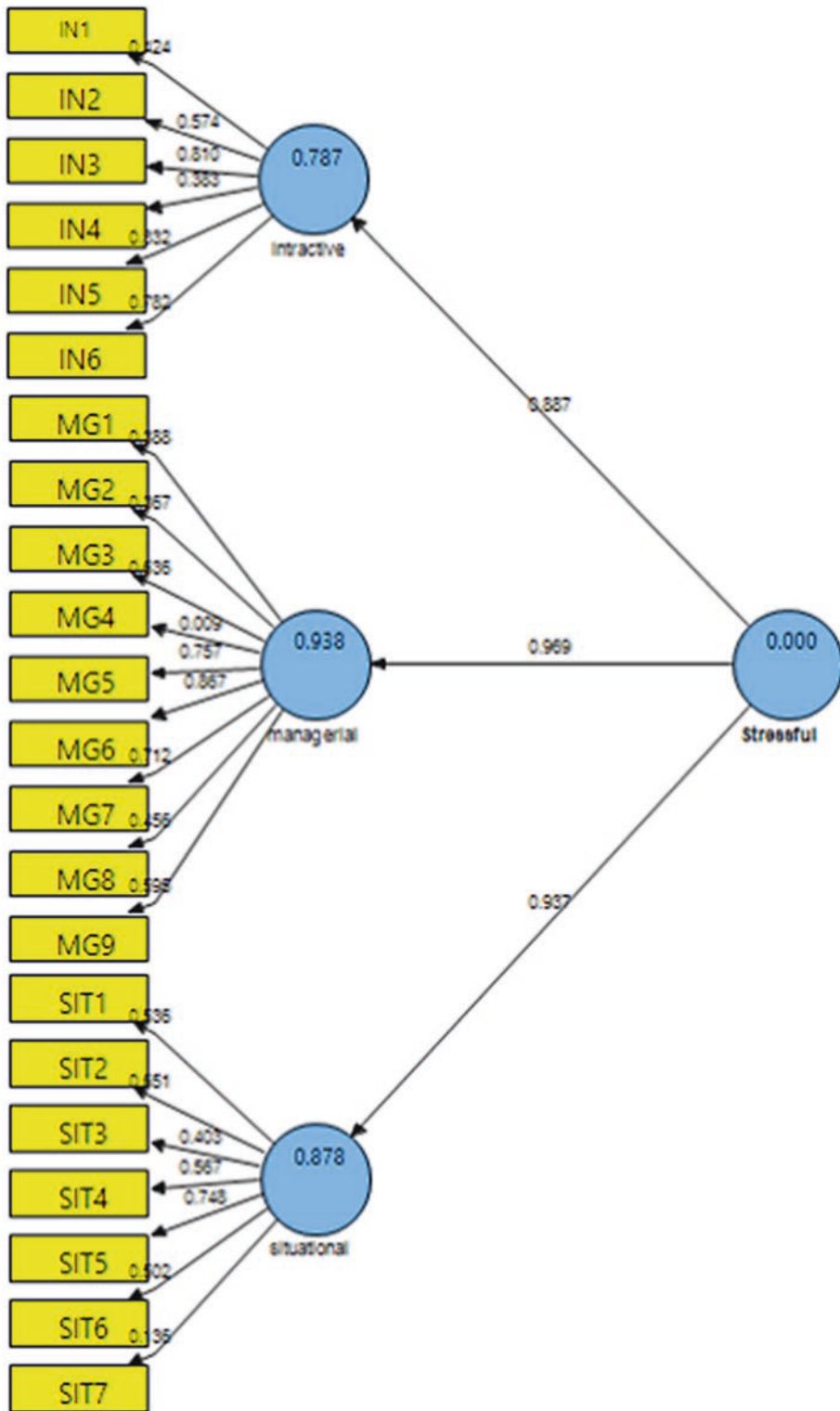
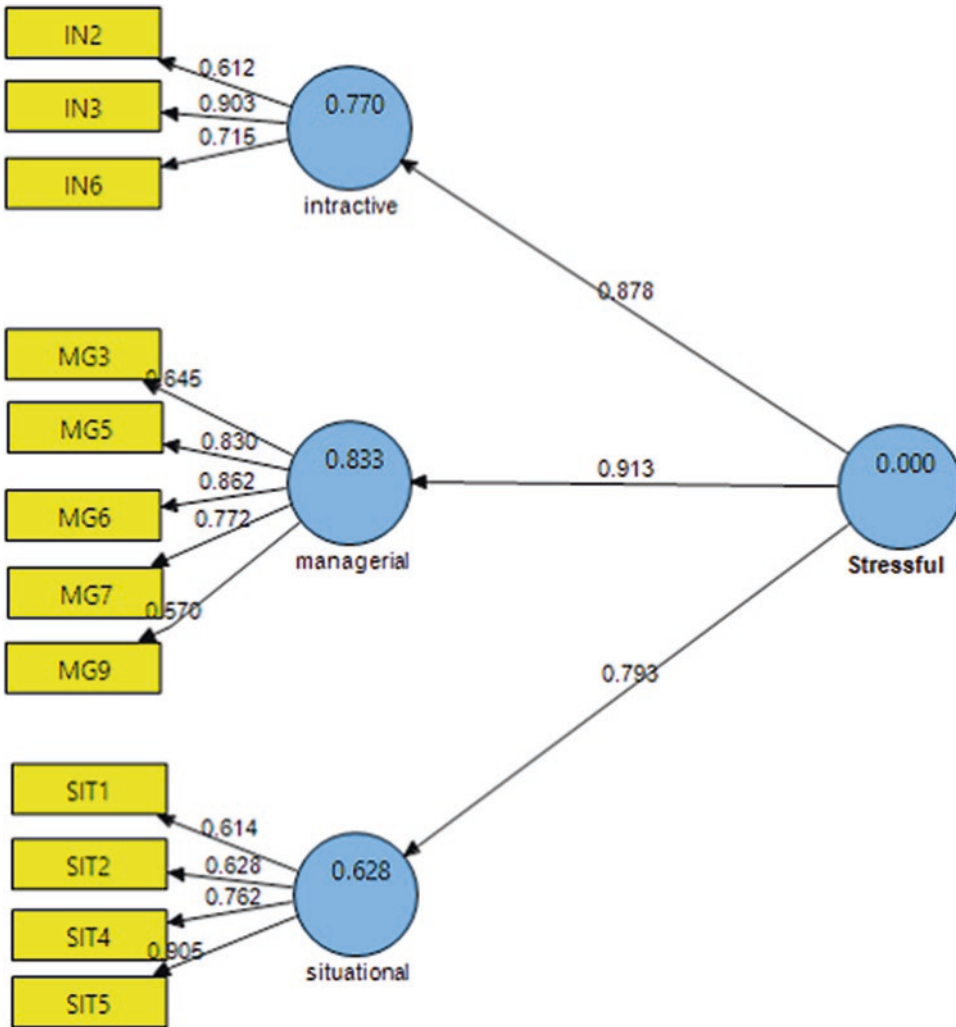

Fig. 14.1 Outer loadings for initial second-order PLS-SEM for stress scale



**Fig. 14.2** Outer loadings for modified *second-order PLS-SEM* for stress scale. \*All paths were significant ( $P < 0.05$ )

**Table 14.3** Stability, composite reliability, internal consistency reliability, and average variance extracted of the instrument

Reliability	Stability (test–retest)	Composite reliability	Internal consistency (Cronbach’s alpha)	Average variance extracted
Stressful	0.87	0.850	0.890	–
Interactive	0.81	0.793	0.632	0.567
Managerial	0.88	0.859	0.794	0.554
Situational	0.84	0.822	0.713	0.543

### 14.4 Discussion

This study has described the use of the working nurses stress scale in critical care units and con-

firmed its reliability and validity in Iran based on a PLS-SEM approach. This is the first time that such a tool has been developed with a sufficiently large sample size across different hos-



**Table 14.4** Discriminate validity (Fornell-Larcker criterion) of the instrument based on latent variable correlations

	Interactive	Managerial	Situational
Interactive	<b>0.760</b>		
Managerial	0.727	<b>0.744</b>	
Situational	0.589	0.544	<b>0.736</b>

pital units in Iran, in accordance with Iranian culture. The face and content validities of the scale were confirmed by the opinions of a panel of experts. The construct validity was also satisfied by the PLS method. The model had a good level of adequacy and high coefficient of determination values. All item-subscale and subscale-scale relationships were statistically significant. The Fornell-Larcker criterion and AVE assessments indicated that the convergent validity and discriminant validity of the measure were satisfied. The test-retest reliability, internal consistency reliability, and composite reliability were also at satisfactory level for subscales and whole scales.

It is important to mention that we used the PLS approach of SEM, and not a covariance-based method, since PLS has minimal requirements on measurement scales, sample sizes, and residual distributions. In addition, the PLS approach focuses on maximizing the variance of the dependent variables explained by the independent variables and thereby avoids the problems of inadmissible solutions and factor indeterminacy associated with a covariance-based approach [34]. The algorithm involved in the PLS approach comprises a series of ordinary least squares equations and, therefore, identification is not a problem for recursive models. In addition, second-order PLS procedures were used in this study, which can be estimated by the standard PLS algorithm [24]. Finally, PLS is considered a better approach for clarifying complex relationships [34, 35]. PLS assumes consistency of the parameter estimates and this was satisfied in our study considering the large sample size. Standard errors need to be estimated in PLS through resampling procedures such as jackknifing or bootstrapping, and p-values of coefficients can be estimated by the jackknife

method resulting from a blindfolded resampling technique [36].

The application of the tool developed here revealed that age, gender, education, marital status, working shift, system collaboration and support difference, working experience, and child number were significantly associated with stress levels of critical care nurses in Iranian hospitals, supporting the discriminant validity of the scales and subscales. Previous instruments designed for stress evaluation of nurses have been conducted in different countries, although these were limited with respect to the type of hospital ward and sample size. The most established and widely used tool designed for measuring the frequency and major sources of stress experienced by nurses on hospital units is the Nursing Stress Scale (NSS), which uses a 34-item, 4-point Likert scale [37].

The results of the current scale showed consistency with previous studies [38], and the high Cronbach's alpha (0.85) revealed a good level of internal consistency, confirming its reliability as an instrument for assessment of stress in Iranian nurses. The final version of this tool included 22 items in 3 domains: *interactive and communicative* (6 items), *managerial and administrative* (9 items), and *exclusive and situational* (7 items) subscales. In previous studies, job stressors for nurses were categorized into six broad domains: (1) intrinsic job characteristics; (2) organizational roles; (3) work relationships; (4) career growth issues; (5) organizational factors including climate, structure, and culture; and (6) the home-work interface. All six of these components are included in three domains of the instrument developed in the present study. This resulted in the present instrument having fewer items than previous tools. We suggest that the use of lower numbers of items increases the willingness of participants to the tool.

The items of the first subscales (interactive and communicative) include dealing with patients' pain and suffering, family presence, relatives reactions, patients' reactions, poor cooperation in the intensive care unit, and poor cooperation and communication in other departments. These items are in line with other studies which found that poor relationships with individuals from other

**Table 14.5** Results of GEE model to assess relationship between the stress components with background variables

Variables	Interactive score			Managerial score			Situational score			Total score		
	B	SE	P-value	B	SE	P-value	B	SE	P-value	B	SE	P-value
<b>Gender (male)</b>	<b>0.95</b>	<b>0.09</b>	<b>&lt;0.01</b>	<b>1.16</b>	<b>0.13</b>	<b>&lt;0.01</b>	<b>0.77</b>	<b>0.14</b>	<b>&lt;0.01</b>	<b>1.55</b>	<b>0.10</b>	<b>&lt;0.01</b>
<b>Education level</b>												
Associate	<b>-0.91</b>	<b>0.33</b>	<b>0.01</b>	<b>-1.61</b>	<b>&lt;0.01</b>	<b>&lt;0.01</b>	NA	NA	NA	<b>-1.57</b>	<b>0.58</b>	<b>0.01</b>
Baccalaureate	-0.21	0.33	0.51	<b>0.16</b>	<b>&lt;0.01</b>	<b>&lt;0.01</b>	NA	NA	NA	-0.43	0.58	0.46
Master	<b>0.71</b>	<b>0.33</b>	<b>0.03</b>	<b>0.97</b>	<b>&lt;0.01</b>	<b>&lt;0.01</b>	NA	NA	NA	-0.15	0.58	0.80
PhD	<b>Referent</b>	-	-	-	-	-	-	-	-	-	-	-
<b>Marital status</b>												
Not married	0.32	0.94	0.73	<b>-0.49</b>	<b>&lt;0.01</b>	<b>&lt;0.01</b>	-0.05	1.73	0.98	0.05	0.66	0.94
Married	-0.11	0.93	0.91	<b>-1.33</b>	<b>&lt;0.01</b>	<b>&lt;0.01</b>	-0.53	1.72	0.76	-0.34	0.65	0.60
Separated or widowed	<b>Referent</b>	-	-	-	-	-	-	-	-	-	-	-
<b>Working shift</b>												
Morning	-0.06	0.05	0.22	<b>-0.15</b>	<b>0.07</b>	<b>0.04</b>	<b>0.28</b>	<b>0.08</b>	<b>&lt;0.01</b>	<b>-0.20</b>	<b>0.07</b>	<b>&lt;0.01</b>
Evening	<b>-0.21</b>	<b>0.05</b>	<b>&lt;0.01</b>	<b>-0.51</b>	<b>0.07</b>	<b>&lt;0.01</b>	<b>0.54</b>	<b>0.08</b>	<b>&lt;0.01</b>	<b>-0.39</b>	<b>0.07</b>	<b>&lt;0.01</b>
Night	<b>-0.17</b>	<b>0.05</b>	<b>&lt;0.01</b>	<b>-0.17</b>	<b>0.08</b>	<b>0.03</b>	<b>0.67</b>	<b>0.08</b>	<b>&lt;0.01</b>	<b>-0.73</b>	<b>0.06</b>	<b>&lt;0.01</b>
Rotation	<b>Referent</b>	-	-	-	-	-	-	-	-	-	-	-
<b>Patient-to-nurse ratio</b>												
One	-0.18	0.93	0.84	-0.31	1.29	0.81	-0.42	1.71	0.80	-0.26	0.65	0.69
Two	-0.11	0.11	0.32	-0.17	0.16	0.29	-0.33	0.18	0.07	-0.06	0.13	0.66
Three	<b>Referent</b>	-	-	-	-	-	-	-	-	-	-	-
<b>Collaboration</b>												
low	<b>3.12</b>	<b>0.04</b>	<b>&lt;0.01</b>	<b>2.56</b>	<b>0.04</b>	<b>&lt;0.01</b>	<b>5.75</b>	<b>0.04</b>	<b>&lt;0.01</b>	<b>2.17</b>	<b>0.06</b>	<b>&lt;0.01</b>
moderate	<b>5.40</b>	<b>0.04</b>	<b>&lt;0.01</b>	<b>4.64</b>	<b>0.06</b>	<b>&lt;0.01</b>	<b>2.32</b>	<b>0.07</b>	<b>&lt;0.01</b>	<b>1.23</b>	<b>0.06</b>	<b>&lt;0.01</b>
high	<b>Referent</b>	-	-	-	-	-	-	-	-	-	-	-
<b>Supportive supervisor (yes)</b>	<b>-0.20</b>	<b>0.08</b>	<b>0.01</b>	0.22	0.12	0.07	<0.01	0.13	0.97	<b>-0.20</b>	<b>0.09</b>	<b>0.02</b>

<b>Working In holiday days (yes)</b>	-0.08	0.08	0.33	<b>0.07</b>	< <b>0.01</b>	-0.01	0.14	0.97	-0.03	0.11	0.81
<b>ICU types</b>											
Surgical	-0.01	0.07	0.94	-0.07	0.11	0.54	0.12	0.75	-0.31	<b>0.09</b>	< <b>0.01</b>
Medical	-0.01	0.07	0.92	0.03	0.10	0.76	0.11	0.95	-0.02	0.09	0.85
Toxicological	-0.02	0.08	0.81	0.00	0.12	0.98	0.14	0.78	0.13	0.10	0.23
Neurology	0.00	0.09	0.96	0.00	0.13	0.98	0.14	0.88	-0.07	0.11	0.52
Trauma	0.14	0.08	0.10	-0.03	0.12	0.82	0.14	0.83	0.07	0.11	0.51
Adult mixed	0.00	0.09	0.98	0.13	0.14	0.36	0.15	0.24	0.12	0.12	0.31
Pediatric	0.01	0.09	0.89	0.03	0.13	0.85	0.15	0.95	-0.04	0.11	0.69
Neonatal	-0.04	0.09	0.69	0.02	0.13	0.87	0.15	0.94	-0.02	0.11	0.85
Pediatric and neonatal mixed	0.07	0.10	0.47	-0.06	0.15	0.67	0.16	0.74	-0.07	0.13	0.60
Coronary	0.07	0.06	0.30	-0.04	0.10	0.65	0.11	0.83	0.05	0.08	0.58
Dialysis	<b>Referent</b>	-	-	-	-	-	-	-	-	-	-
<b>ICU system (semi-close)</b>	0.06	0.05	0.23	0.07	0.07	0.31	0.08	0.34	0.10	0.06	0.11
Age (yrs)	-0.09	<b>0.01</b>	< <b>0.01</b>	-0.03	0.01	0.05	0.01	0.11	-0.08	<b>0.01</b>	< <b>0.01</b>
Clinical experience (yrs)	-0.02	0.01	<b>0.01</b>	-0.08	<b>0.01</b>	< <b>0.01</b>	<b>0.01</b>	< <b>0.01</b>	-0.14	<b>0.01</b>	< <b>0.01</b>
BMI (kg/m <sup>2</sup> )	0.00	0.00	0.55	-0.01	0.01	0.13	0.01	0.88	0.00	0.00	0.78
Children (number)	0.01	0.02	0.52	-0.03	0.03	0.36	0.03	0.83	-0.06	<b>0.02</b>	<b>0.02</b>
ICU bed (number)	-0.01	0.01	0.40	0.00	0.01	0.93	0.01	0.98	0.00	0.01	0.75

GEE generalized estimating equation, B regression coefficient, SE, standard error  
 NA not applicable in the GEE model

professions may lead to lower levels of confidence and higher stress levels and better relationships with other professions [39]. In addition, exposures to pain, suffering, and traumatic life events that nurses experience on a daily basis can contribute to stress [40]. Similarly, another study showed that the least stressful subscale was inadequate preparation to deal with emotional needs of patients and families (feeling inadequately prepared to help with the emotional needs of patients and their families), and factors of the intense emotional support needed for patients and families are another burden of stress placed on nurses [41].

Studies have shown that an individual nurse may behave differently in their perception of stress. The results of the previous study [1] showed that age, marital status, working shift, and years of experience of nurses had significant associations with levels of stress. However, sex, education, and BMI showed no significant association with stress level. Similarly, Li et al. showed that gender and education were not linked with stress but marital status did show a significant effect [42]. In addition, Chang et al. concluded that education, marital status, and number of children did not have a significant association with the level of stress [43].

Similar to our findings about decision-making power in the subset of exclusive and situational subscale and physician dependency in the subset of managerial and administrative subscale, Kang et al. found that lack of autonomy and independence in making decisions was frequently stressful for staff nurses in clinical area [43]. The majority of staff nurses sometimes felt unable to make decisions and powerless to change unsatisfactorily situations. Workload and staff shortage were two other aspects of the managerial and administrative subscale, similar to the findings of a tool developed to assess nurse stress in Saudi Arabia [44]. Another study showed that staff nurses did not always utilize their training and experience despite the fact that some felt inadequately trained or equipped for their job [45]. Transition programs specifically designed to bridge the gap between the academic and service setting and prepare nurses to utilize critical thinking skills in management of acutely ill patients are

therefore likely to be important to ensure nurses have sufficient confidence to deal with the degree of autonomy they are required to demonstrate.

The strengths of this study were the use of multistage random sampling methods and the consideration of different nurse groups in different wards and the large sample size across 31 cities in Iran. This resulted in a sample size significantly greater than the minimal requirement to conduct the PLS-CFA. There was a robust correlation between the level of stress and social and cultural status. The construct validity showed that stress scale items were grouped under three components which may provide greater incentive to participants in completion of the study compared with other studies on stress scale development that used components on the scale ranging from four to seven components [46–49]. This is supported by the finding that most of the above studies identified three major components linked with stress among nurses (lack of adequate staffing, dealing with difficult patients, and high workload). The large sample size of this investigation resulted in a higher response rate (about 80%) as compared to other studies (about 55.1 and 76.2%) [50, 51].

A potential limitation of the present tool relates to the fact that it was developed to assess stress of nurses in critical care units in Iran. Thus, it is not necessarily generalizable for assessment of nurses in healthcare institutions in other countries. Moreover, there are some aspects of the Iranian healthcare system that limit the generalizability of the findings. For example, most academic and tertiary care ICUs in the USA are closed systems and those in Iran are generally semi-closed or open units. We did not collect data on individual nurse's psychiatric symptoms or diagnoses. We also did not collect data on workplace violence or lateral hostilities.

## 14.5 Conclusion

The study demonstrated a valid and reliable scale to assess stress-related factors in the home and workplace for nurses. As the tool is short and simple to use, it is convenient for assessment of

nurses in critical care units. Further studies applying this developed tool are recommended to further elucidate the dimensions of stress in Iranian nurses, with the overall aim of improving working conditions for these critical workers in healthcare. Finally, this approach should be translated for use in other countries and cultures affected by the current COVID-19 outbreak. As a second wave of COVID-19 or outbreaks of further viruses can occur, such a response becomes even more critical to protect our healthcare professionals working on the frontlines.

**Acknowledgement** The authors would like to thank the guidance and advice from the Clinical Research Development Unit of Baqiyatallah Hospital.

## References

- Vahedian-Azimi A, Hajjesmaeli M, Kangasniemi M, Fornés-Vives J, Hunsucker RL, Rahimibashar F et al (2019) Effects of stress on critical care nurses: a national cross-sectional study. *J Intensive Care Med* 34(4):311–322
- Salmon G, Morehead A (2019) Posttraumatic stress syndrome and implications for practice in critical care nurses. *Crit Care Nurs Clin North Am* 31(4):517–526
- Mealer M, Jones J, Meek P (2017) Factors affecting resilience and development of posttraumatic stress disorder in critical care nurses. *Am J Crit Care* 26(3):184–192
- Tirgari B, Azizzadeh Forouzi M, Ebrahimpour M (2019) Relationship between posttraumatic stress disorder and compassion satisfaction, compassion fatigue, and Burnout in Iranian psychiatric nurses. *J Psychosoc Nurs Ment Health Serv* 57(3):39–47  
<https://coronavirus.jhu.edu/map.html>
- Maunder R, Hunter J, Vincent L et al (2003) The immediate psychological and occupational impact of the 2003 SARS outbreak in a teaching hospital. *CMAJ* 168(10)
- Bai Y, Lin CC, Lin CY, Chen JY, Chue CM, Chou P (2004) Survey of stress reactions among health care workers involved with the SARS outbreak. *Psychiatr Serv* 55(9):1055–1057
- Chua SE, Cheung V, Cheung C et al (2004) Psychological effects of the SARS outbreak in Hong Kong on high-risk health care workers. *Can J Psychiatr* 49(6):391–393
- Koh D, Lim MK, Chia SE, Ko SM, Qian F, Ng V et al (2005) Risk perception and impact of Severe Acute Respiratory Syndrome (SARS) on work and personal lives of healthcare workers in Singapore what can we learn? *Med Care* 43(7):676–682
- Lee AM, Wong JG, McAlonan GM, Cheung V, Cheung C, Sham PC et al (2007) Stress and psychological distress among SARS survivors 1 year after the outbreak. *Can J Psychiatr* 52(4):233–240
- Khalid I, Khalid TJ, Qabajah MR, Barnard AG, Qushmaq IA (2016) Healthcare workers emotions, perceived stressors and coping strategies during a MERS-CoV outbreak. *Clin Med Res* 14(1):7–14
- Bukhari EE, Temsah MH, Aleyadhy AA, Alrabiaa AA, Alhboob AA, Jamal AA (2016) Middle East respiratory syndrome coronavirus (MERS-CoV) outbreak perceptions of risk and stress evaluation in nurses. *J Infect Dev Ctries* 10(8):845–850
- Abolfotouh MA, AlQarni AA, Al-Ghamdi SM, Salam M, Al-Assiri MH, Balkhy HH (2017) An assessment of the level of concern among hospital-based health-care workers regarding MERS outbreaks in Saudi Arabia. *BMC Infect Dis* 17(1):4. <https://doi.org/10.1186/s12879-016-2096-8>
- Alsubaie S, Hani Temsah M, Al-Eyadhy AA, Gossady I, Hasan GM, Al-Rabiaah A et al (2019) Middle East respiratory syndrome coronavirus epidemic impact on healthcare workers' risk perceptions, work and personal lives. *J Infect Dev Ctries* 13(10):920–926
- Tuohy A, Knussen C, Wrennall MJ (2005) Effects of age on symptoms of anxiety and depression in a sample of retired police officers. *Psychol Aging* 20(2):202–210
- Blazer D, George LK, Hughes D (1991) Generalised anxiety disorder. In: Robins LN, Regier DA (eds) *Psychiatric disorders in America: the epidemiological catchment area study*. The Free Press, New York, NY, pp 180–203. ISBN 10: 0029265711
- Bunce D, Handley R, Gaines SO Jr (2008) Depression, anxiety, and within-person variability in adults aged 18–85 years. *Psychol Aging* 23(4):848–858
- <https://www.nia.nih.gov/health/depression-and-older-adults>
- Happell B, Reid-Searl K, Dwyer T, Caperchione CM, Gaskin CJ, Burke KJ (2013) How nurses cope with occupational stress outside their workplaces. *Collegian* 20(3):195–199
- Pisaniello SL, Winefield HR, Delfabbro PH (2012) The influence of emotional labour and emotional work on the occupational health and wellbeing of South Australian hospital nurses. *J Vocational Behav* 80(3):579–591
- Rickard G, Lenthall S, Dollard M, Opie T, Knight S, Dunn S et al (2012) Organisational intervention to reduce occupational stress and turnover in hospital nurses in the Northern Territory, Australia. *Collegian* 19(4):211–221
- Hashemian SMR, Farzanegan B, Fathi M, Ardehali SH, Vahedian-Azimi A, Asghari-Jafarabadi M et al (2015) Stress among Iranian nurses in critical wards. *Iran Red Crescent Med J* 17(6):e22612. <https://doi.org/10.5812/ircmj.22612v2>
- Von Elm E, Altman DG, Egger M, Pocock SJ, Gøtzsche PC, Vandenbroucke JP (2007) The Strengthening of Reporting of Observational Studies in Epidemiology

- (STROBE) statement: guidelines for reporting observational studies. *Ann Intern Med* 147(8):573–577
24. Hair JF, Black WC, Babin BJ, Anderson RE (2014) *Multivariate data analysis*. Pearson Education Limited, London. ISBN 10:1-292-02190-X
  25. Hasson F, Keeney S, McKenna H (2000) Research guidelines for the Delphi survey technique. *J Adv Nurs* 32:1008–1015
  26. Abdi H (2007) Kendall rank correlation. In: Salkind NJ (ed) *Encyclopedia of measurement and statistics*. Sage Publications, Inc., Thousand Oaks, CA. ISBN-10: 1412916119
  27. Lipid and Blood Pressure Meta-analysis Collaboration (LBPAC) Group, Serban C, Sahebkar A, Mikhailidis DP, Ursoniu S et al (2015) Impact of statin therapy on coronary plaque composition: a systematic review and meta-analysis of virtual histology intravascular ultrasound studies. *BMC Med* 13:229. <https://doi.org/10.1186/s12916-015-0459-4>
  28. Holland BA (2001) A comprehensive model for assessing service-learning and community-university partnerships. *New Direct Higher Educ* 2001(114):51–60
  29. Farrell AM (2010) Insufficient discriminant validity: a comment on Bove, Pervan, Beatty, and Shiu (2009). *J Business Res* 63(3):324–327
  30. Henseler J, Ringle CM, Sinkovics RR (2009) The use of partial least squares path modeling in international marketing. In: Cavusgil T, Sinkovics RR, Ghauri PN (eds) *New challenges to international marketing*. Emerald Group Publishing Limited, Bingley, UK, pp 277–319. ISBN-10: 1848554680
  31. Tenenhaus M, Vinzi VE, Chatelin YM, Lauro C (2005) PLS path modeling. *Comput Stat Data Anal* 48(1):159–205
  32. Wetzels M, Odekerken-Schröder G, Van Oppen C (2009) Using PLS path modeling for assessing hierarchical construct models: guidelines and empirical illustration. *MIS Quart* 33:177–195
  33. Chin WW (1998) The partial least squares approach for structural equation modeling. In: Marcoulides GA (ed) *Modern methods for business research*. Lawrence Erlbaum Associates Publishers, Mahwah, NJ, pp 295–336. ASIN: B00LKMQO4I
  34. Fornell C, Bookstein FL (1982) Two structural equation models: LISREL and PLS applied to consumer exit-voice theory. *J Mark Res* 19(4):440–452
  35. Fornell C, Lorange P, Roos J (1990) The cooperative venture formation process: a latent variable structural modeling approach. *Manag Sci* 36(10):1246–1255
  36. Lohmöller JB (1984) *LVPLS 1.6 program manual: latent variables path analysis with partial least-squares estimation; mit 2 Disketten Version 1.8: Zentralarchiv für empirische Sozialforschung*. [https://books.google.co.uk/books/about/LVPLS\\_1\\_6\\_program\\_manual.html?id=uAbOcQAACAAM&redir\\_esc=y](https://books.google.co.uk/books/about/LVPLS_1_6_program_manual.html?id=uAbOcQAACAAM&redir_esc=y)
  37. Gray-Toft P, Anderson JG (1981) The nursing stress scale: development of an instrument. *J Behav Assess* 3(1):11–23
  38. Souza ACD, Alexandre NMC, Guirardello EDB (2017) Psychometric properties in instruments evaluation of reliability and validity. *Epidemiol Serv Saude* 26(3):649–659
  39. Jordan TR, Khubchandani J, Wiblehauser M (2016) The impact of perceived stress and coping adequacy on the health of nurses: a pilot investigation. *Nurs Res Pract* 2016:5843256. <https://doi.org/10.1155/2016/5843256>
  40. Cohen-Katz J, Wiley SD, Capuano T, Baker DM, Shapiro S (2005) The effects of mindfulness-based stress reduction on nurse stress and burnout, Part II: a quantitative and qualitative study. *Holist Nurs Pract* 19(1):26–35
  41. Kamal SM, Al-Dhshan M, Abu-Salameh K, Abuadas F, Hassan M (2012) The effect of nurses' perceived job related stressors on job satisfaction in Taif governmental hospitals in Kingdom of Saudi Arabia. *J Am Sci* 8(3):119–125
  42. Li J, Yang W, Cho SI (2006) Gender differences in job strain, effort-reward imbalance, and health functioning among Chinese physicians. *Soc Sci Med* 62(5):1066–1077
  43. Kang MG, Koh SB, Cha BS, Park JK, Baik SK, Chang SJ (2005) Job stress and cardiovascular risk factors in male workers. *Prev Med* 40(5):583–588
  44. Zaghoul AA (2008) Developing and validating a tool to assess nurse stress. *J Egypt Public Health Assoc* 83(3):223–227
  45. Halfer D (2007) A magnetic strategy for new graduate nurses. *Nurs Econ* 25(1):6–11, 3; quiz 12
  46. Motzer SA, Hertig V (2004) Stress, stress response, and health. *Nurs Clin North Am* 39(1):1–17
  47. Nayeri ND, Negarandeh R, Vaismoradi M, Ahmadi F, Faghihzadeh S (2009) Burnout and productivity among Iranian nurses. *Nurs Health Sci* 11(3):263–270
  48. Rego AC, Araujo Filho I, Damasceno BP, Egito ES, Silveira IA, Brandao-Neto J et al (2007) Simvastatin improves the healing of infected skin wounds of rats. *Acta Cir Bras* 22(Suppl 1):57–63
  49. Oyeleye O, Hanson P, O'Connor N, Dunn D (2013) Relationship of workplace incivility, stress, and burnout on nurses' turnover intentions and psychological empowerment. *J Nurs Adm* 43(10):536–542
  50. Kakemam E, Raeissi P, Raoofi S, Soltani A, Sokhanvar M, Visentin D et al (2019) Occupational stress and associated risk factors among nurses: a cross-sectional study. *Contemp Nurse* 55(2–3):237–249
  51. Tran TTT, Nguyen NB, Luong MA, Bui THA, Phan TD, Ngo TH et al (2019) Stress, anxiety and depression in clinical nurses in Vietnam: a cross-sectional survey and cluster analysis. *Int J Ment Health Syst* 13:3. <https://doi.org/10.1186/s13033-018-0257-4>