

Daizhong Su *Editor*

---

# Sustainable Product Development

Tools, Methods and Examples

# Sustainable Product Development

Daizhong Su  
Editor

# Sustainable Product Development

Tools, Methods and Examples

 Springer

*Editor*

Daizhong Su  
Advanced Design and Manufacturing  
Engineering Centre, School of Architecture,  
Design and the Built Environment  
Nottingham Trent University  
Nottingham, UK

ISBN 978-3-030-39148-5      ISBN 978-3-030-39149-2 (eBook)  
<https://doi.org/10.1007/978-3-030-39149-2>

© Springer Nature Switzerland AG 2020

This work is subject to copyright. All rights are reserved by the Publisher, whether the whole or part of the material is concerned, specifically the rights of translation, reprinting, reuse of illustrations, recitation, broadcasting, reproduction on microfilms or in any other physical way, and transmission or information storage and retrieval, electronic adaptation, computer software, or by similar or dissimilar methodology now known or hereafter developed.

The use of general descriptive names, registered names, trademarks, service marks, etc. in this publication does not imply, even in the absence of a specific statement, that such names are exempt from the relevant protective laws and regulations and therefore free for general use.

The publisher, the authors and the editors are safe to assume that the advice and information in this book are believed to be true and accurate at the date of publication. Neither the publisher nor the authors or the editors give a warranty, expressed or implied, with respect to the material contained herein or for any errors or omissions that may have been made. The publisher remains neutral with regard to jurisdictional claims in published maps and institutional affiliations.

This Springer imprint is published by the registered company Springer Nature Switzerland AG  
The registered company address is: Gewerbestrasse 11, 6330 Cham, Switzerland

# Preface

This book offers a comprehensive review of sustainability and product design, providing useful information on the relevant regulations/standards, methods and tools for industries to meet the increasing market demands for eco-products, while reducing their impact on the environment. The examples presented allow readers to gain insights into sustainable products. The authors also explain how to develop products with sustainability features by applying tools and methods. These tools/methods include

- Regulations/directives related to sustainable product development;
- Eco-point and eco-accounting infrastructure;
- Popular lifecycle analysis software packages;
- Environmental and social lifecycle impact assessment methods;
- Lifecycle inventory databases;
- ICT and traceability technologies for sustainable product development;
- Genetic algorithm for sustainable product design optimisation;
- Sustainable design and manufacture;
- Integrated approach for sustainable product development.

The descriptions of each sustainability method and tool are accompanied by easy-to-understand guidelines and examples. Seven different case studies are also presented, which are in the areas of petroleum, vegetable farming, LED lighting, industrial gearbox and flooring products. Those examples and case studies illustrate how to apply the tools and methods into the development of real sustainable products.

This book results from the research in sustainable product design and manufacture conducted by the Advanced Design and Manufacturing Engineering Centre (ADMEC), Nottingham Trent University, UK. As the leader of the research, I am grateful for the contributions received from the ADMEC members and international/industrial collaborators.

I also thank the funding organisations for providing grants to support the following research projects, the results of which are directly related to this book:

- ‘CIRC4Life—A circular economy approach for lifecycles of products and services’, 2018–2021, supported by the European Commission H2020 Circular Economy Programme (Grant agreement No. 776503)
- ‘Research and development of new environmental protection flooring products made from composite materials’, 2015–2017, supported by the Ministry of Science and Technology, China. International collaborative project (Grant No. 2015DFA51330)
- ‘cycLED—Cycling resources embedded in systems containing Light Emitting Diodes’, 2012–2015, supported by the European Commission FP7 Eco-innovation programme (Grant agreement No. 282793)
- ‘myEcoCost—A consumer oriented prototype: forming the nucleus of a novel Ecological Accounting System.’ 2012–2015, Supported by the European Commission FP7-ENV-2012 programme (Grant agreement No. 308530)
- ‘AgitatorCBM: Condition based maintenance of agitators using advanced condition monitoring and Internet/wireless technologies’, 2011–2012, supported by the European Commission FP7 Marie Curie International Incoming Fellowship programme (Grant agreement No. PIIF-GA-2009-253403)
- ‘Ecolights: Market deployment of eco-lighting products’, 2012–2014, supported by the European Commission CIP Eco-innovation programme (Grant agreement No. ECO/11/304409)
- ‘Development of a novel system of solid desiccant dehumidification for low carbon emission buildings’, 2009–2010, supported by the UK Sustainable Construction Innovation Network (Project No. 01DSG R1806)

Nottingham, UK

Prof. Daizhong Su  
Editor and lead author of the book

# Contents

<b>1</b>	<b>Introduction and Sustainable Product Development</b> . . . . .	<b>1</b>
	Daizhong Su	
<b>Part I Sustainability Tools</b>		
<b>2</b>	<b>Review of Directives, Regulations and Standards Related to Sustainable Product Design and Manufacture</b> . . . . .	<b>15</b>
	Jose L. Casamayor and Daizhong Su	
<b>3</b>	<b>Review of Life Cycle Impact Assessment (LCIA) Methods and Inventory Databases</b> . . . . .	<b>39</b>
	You Wu and Daizhong Su	
<b>4</b>	<b>Guidelines for Selection of Life Cycle Impact Assessment Software Tools</b> . . . . .	<b>57</b>
	Daizhong Su, Zhongming Ren, and You Wu	
<b>Part II Methods for Sustainable Product Design</b>		
<b>5</b>	<b>Eco-Accounting Infrastructure</b> . . . . .	<b>73</b>
	Daizhong Su and Wenjie Peng	
<b>6</b>	<b>Application of Information and Communication Technologies for Eco-Accounting</b> . . . . .	<b>85</b>
	Wenjie Peng, You Wu, and Daizhong Su	
<b>7</b>	<b>Social Life Cycle Assessment</b> . . . . .	<b>127</b>
	You Wu and Daizhong Su	
<b>8</b>	<b>Life Cycle Inventory Management</b> . . . . .	<b>153</b>
	You Wu and Daizhong Su	
<b>9</b>	<b>Genetic Algorithm for Sustainable Product Design Optimisation</b> . . . . .	<b>167</b>
	Zhongming Ren and Daizhong Su	

### **Part III Case Studies of Product Life Cycle Assessments**

- 10 Gearbox Life Cycle Assessment** ..... 193  
Daizhong Su and Zhongming Ren
- 11 An Analysis and Evaluation of the Environmental Impacts of ‘Upstream’ Petroleum Operations** ..... 221  
Ammar Irhoma, Daizhong Su, and Martin Higginson
- 12 Environmental Impact Assessment of Farming with Combined Methods of Life Cycle Assessment and Farm Carbon Calculator** ..... 249  
Daizhong Su, Jonathan Smith, You Wu, and Zhongming Ren
- 13 Assessment of the Environmental Impact of Lighting Product** .... 271  
Jose L. Casamayor and Daizhong Su
- 14 Comparative Life Cycle Assessment of Raised Flooring Products** ..... 293  
Shuyi Wang, Daizhong Su, Shifan Zhu, and Qianren Zhang

### **Part IV Case Studies of Integrated Approach for Sustainable Product Development**

- 15 Integrated Approach for Eco-Lighting Product Development** ..... 313  
Jose L. Casamayor and Daizhong Su
- 16 Integrated Approach for Sustainable Flooring Product Development** ..... 351  
Daizhong Su, You Wu, Wenjie Peng, Shuyi Wang, Shifan Zhu, and Qianren Zhang



# About the Editor

The book is authored by a team of researchers, educators and engineers. The authors are members of the Advanced Design and Manufacturing Engineering Centre, Nottingham Trent University, UK, and their international and industrial partners in conducting the research reported in this book. The author team has extensive expertise in the subject areas covered by this book, including product design and manufacture, production and consumption, recycle and reuse, sustainability, circular economy, information technology, traceability and other related areas, which enriched the contents and enhanced the quality of the book.

The team leader and key author of the book, Prof. Daizhong Su, has been working in product design and manufacture for more than 35 years and conducting research in sustainable product development for more than 20 years. He has more than 290 publications, successfully managed and conducted a number of projects with a total project budget of around 37 million Euros. His research has been supported by national and international funding organisations, including the European Commission (H2020, FP7, CIP Eco-innovation, Asia link and Asia ICT programmes), research councils, governmental departments, regional development agencies, sustainable construction networks, international collaboration programmes, industries and others.

# Chapter 1

## Introduction and Sustainable Product Development



Daizhong Su

**Abstract** This book consists of 16 chapters which are grouped into four parts including tools, methods, LCA case studies and integrated approach for sustainable product development. Overview of this book is given with brief information of the 16 chapters. The scope of sustainable product development is presented. The sustainable product development process is detailed with explanation of the sustainable product development through the product lifecycle and its objective, as well as a three-tiers approach for sustainable product design. The integration of methods and tools through the product development process is described, and all the tools and methods presented in other chapters of this book are relevant to this integrated approach. At the end, the novel contributions of this book are highlighted.

**Keywords** Sustainability · Product design · Life cycle impact assessment · Life cycle analysis · Integrated process

### Abbreviations

EoL	End of product life
GA	Genetic algorithm
GUI	Graphical user interface
ICT	Information communication technologies
LCA	Life cycle analysis
LCI	Life cycle inventory
LCIA	Life cycle impact assessment
PDS	Product design specification
S-LCA	Social life cycle assessment
XML	Extensible Markup Language

---

D. Su (✉)

Advanced Design and Manufacturing Engineering Centre, School of Architecture, Design and the Built Environment, Nottingham Trent University, Nottingham, UK  
e-mail: [Daizhong.su@ntu.ac.uk](mailto:Daizhong.su@ntu.ac.uk)

## 1.1 Overview of the Book

Nowadays, sustainability has been receiving great attention globally. Sustainable product development through its lifecycle stages (material attraction, design, manufacture, use, recycling/reuse, etc.) considerably contribute to this issue, and, hence, there is a demand to up-date the knowledge of sustainable product development. To meet such a demand, this book is proposed.

This book consists of 16 chapters. Apart from this chapter which is an introduction of this book, the rest 15 chapters are grouped in four parts, of which Part I and Part II are about the tools and methods, while Part III and Part VI are examples to illustrate how the tools and methods were applied in industrial cases.

**Part I presents the tools related to sustainable product development**, including directives, regulations, standards, life cycle impact assessment (LCIA) methods and software packages, and life cycle inventory (LCI) databases, which are presented in three chapters:

After brief definitions of the three terms ‘directives’, ‘regulations’ and ‘standards’, Chap. 2 reviews nine directives, two regulations and 26 standards which are related to the design and manufacture of sustainable products.

In Chap. 3, 13 LCIA methods such as CML and ReCiPe, and 10 LCI databases such as Ecoinvent and EXIOBASE, are reviewed. The new initiatives for reducing emissions and improving resource efficiency, Product Environmental Footprint, and the environmental product declaration are introduced. And then how to select the LCIA methods and LCI databases are given. The data formats of the Ecoinvent databases are also examined.

Chapter 4 reviews 10 popular LCIA software packages, such as SimaPro, Gabi and openLCA. They are then analysed against three criteria regarding the function to define the product and its lifecycle, databases, and assessment categories and available LCIA methods. Based on the review and analysis results, guidelines for selection of the tools are proposed.

**Part II is about the methods for sustainable product development**, which are presented in Chaps. 5–9:

Chapter 5 introduces the concept ‘*eco-point*’ which is a reference of the ecological impact values of products, and then the eco-point approach is presented, including ‘eco-debit’ to show the customer’s negative impact resulted from the products purchased, ‘eco-credit’ to credit customers’ positive behaviour of recycling end-of-life products, ‘eco-shopping’ for consumers to gain the ecological information of the products to be purchased, and ‘consumer eco-account’ to record consumers’ ecological footprints. The application of the eco-point approach in sustainable production, eco-shopping, recycle/reuse and consumer eco-accounts are also presented.

In the eco-accounting, large amounts of dynamic data are handled for the calculation of eco-points, and, hence, various information communication technologies (ICT) have to be utilised, which are presented in Chap. 6, including distributed computing, Web-based services, security and privacy, data bridging for online Life Cycle

Analysis (LCA), and necessary NFC, RFID and mobile communication technologies. The design of the software structure is also presented.

In Chap. 7, after a brief literature review, the social life cycle assessment (S-LCA) technology is introduced, including fundamental terminologies, steps for implementing an S-LCA, and seven major assessment methods.

Chapter 8 presents an approach to convertecoinvent data format, EcoSpold, to SQL format for LCI inventory data management and Web based applications. It employs the data extraction programming script and applies extracted data values and information in an SQL database management client. An XML parsing library is used to implement the automated EcoSpold files search and extraction function invoked by a Python script. A Java based graphical user interface (GUI) application is also developed, to help select feasible LCI datasets and automated data file to import into LCIA software.

Chapter 9 starts with the introduction of genetic algorithm (GA) and the GA tool embedded in software package MATLAB. The approach of sustainable product design optimisation using GA is then presented, including the LCIA method/toll selection, a three-tier structure for product LCA, and the sustainable product design optimisation procedure.

**Part III deals with the LCA case studies**, which consists of five chapters, and each chapter presents an LCA case study in a particular industrial application, including industrial gearbox, petroleum products, vegetable farming, lighting products and flooring products.

**Part VI illustrates the integrated approach for sustainable product development** with two case studies, one chapter for each, in the areas of eco-lighting product and sustainable flooring product respectively.

## 1.2 Scope of Sustainable Product Development

The World Commission on Environment and Development (1987) defined sustainable development as the ‘development that meets the needs of the present without compromising the ability of future generations to meet their own needs.’ This is also the ultimate aim of sustainable product development. It comprises three dimensions: environment, economy and social aspects which have to be properly assessed and balanced if a new product is to be designed or an existing one is to be improved (Klöpffer 2003).

In the literature about sustainable product development, both words ‘sustainable’ and ‘ecological (or eco for short)’ are used regarding the sustainability of products. Although they are different in wording, their scopes in sustainable product development are more or less the same. Taking the definition of sustainable design and eco-design as an example, in its basic definition, eco-design is an approach to designing products with special consideration for the environmental impacts of the product during its whole lifecycle (Wikipedia, n.d.). On the other hand, it was stated that Eco-design concepts, must evolve by taking environmental issues and all three

dimensions of sustainability into equal consideration (Byggeth et al. 2007). The three dimensions of sustainability, which are stated in the paragraph above, are the scope of sustainable design. Taking eco-point as another example, as presented in Chap. 5 of this book, the eco-point is calculated using ReCiPe method with three end-points: resource availability, ecosystems, and human health. The third point is out the scope in the basic definition of ecology, but is the issue within the scope of sustainability.

In this book, both words ‘sustainable’ and ‘ecological (or eco)’ are used with similar meaning, but which one is to use in the context depends on its usage in common practices. For example, ‘eco-cost’ is used in the EU supported myEcoCost project (myEcoCost, n.d.), and following the same usage of ‘eco’, eco-point, eco-credit, eco-debit and eco-accounting are used in Chaps. 5 and 6 of this book.

### 1.3 Sustainable Product Development Process

Figure 1.1 shows the sustainable product development process, which covers the whole product life cycle. The middle part shows the product life cycle, from the product design until the end of life; the left part shows the input to the product life cycle, including materials, energy and human labour, while the right part shows the output from the product life cycle, which mainly includes harmful emission and waste. The whole product development process is supported by utilisation of relevant sustainability methods and tools.

#### 1.3.1 Sustainable Product Development Through Product Life Cycle

As shown in the middle of Fig. 1.1, the product life cycle consists several phases, including product design, prototyping and test, production, transportation and retail, and end of life, which are further detailed below with related sustainability issues.

**Product design** phase is initiated by the clients’ demands, and based on the demands, the product design specification (PDS) has to be formulated. With the PDS, designer may propose several concepts. The design concepts are then evaluated with the evaluation criteria derived from the PDS and after evaluation, the best concept is selected. With the best concept selected, the detail design is carried out. It has to be aware that in most cases, the design is an iterative procedure, and re-design may happen at any stage of the design process.

Design is the most important for reducing the product’s impact on environment, because ‘over 80% of all product-related environmental impacts can be influenced during the design phase’ (European Commission 2018). Similar statements can be found in many resources in the literature, for example, Church (2014), Donato (n. d.),

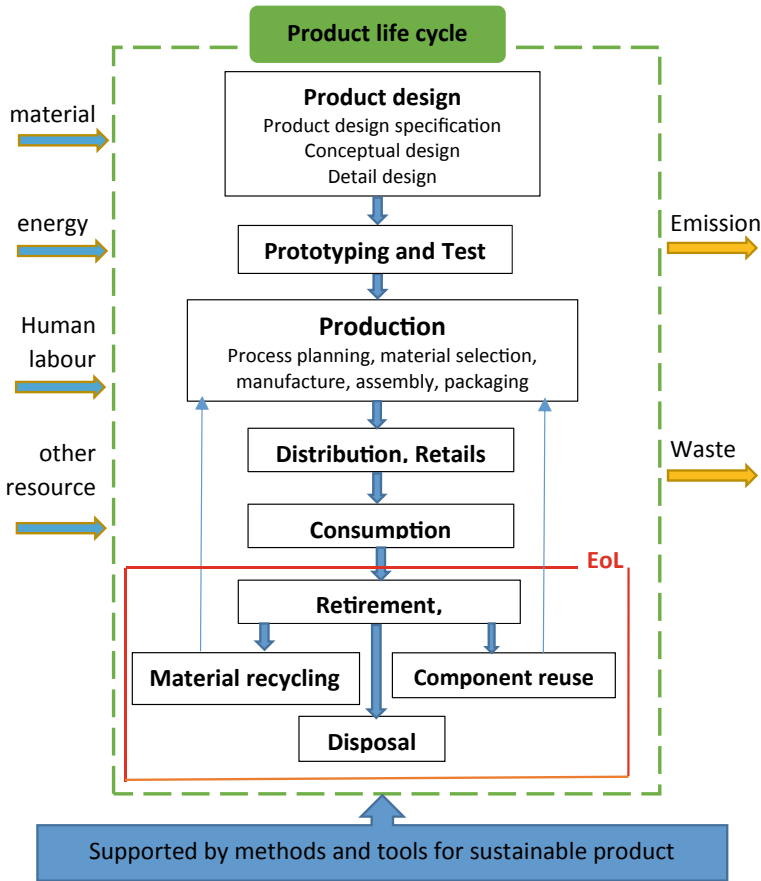

Fig. 1.1 Sustainable product development process

McAloone and Bey (2009), Murray (2013) and more, indicating that it is a common understanding in the product development field.

Many sustainable product design methods have been developed, such as design for environment (Telenko et al. 2016) and ‘Design Products for Sustainability’ (Donato n.d.) which introduces a set of methods including design for embedded carbon, design for recyclability, design for recycled content, design for bio-degradability or compost ability, design for transport efficiency, design for concentration, design for longevity, and design for energy efficiency.

**Prototyping and test** are to validate the design. With the final design, a prototype is made. The prototype is then tested to confirm the expected functions and sustainable features of the product. If the prototype passed the test, then the production starts; if not, the design has to be modified until it passes the test.

**Production** phase normally includes production process planning, material selection, manufacture, assembly and packaging. This is the most important part for

calculation of the ecological impact of the product, because it transfers the design into the product. This phase makes the most ecological impact in the product life cycle, as illustrated in the examples of LCA of all the products shown in this book. Therefore, sustainable production has attracted considerable attention and resulted in many literatures regarding the methods in this area, for example, sustainable manufacture (Moldavska and Welo 2017), cleaner production (Klemes et al. 2012) and lean manufacture (Bhamu and Sangwan 2014).

**Distribution and retail.** There are two routes for products to reach at their consumers: (1) factories—retailers (shops/supermarkets)—consumers, i.e., the products are delivered from the manufacturer to the retailers first, then consumers make their shopping at the shops/supermarkets and take the products home; (2) the products are delivered to the consumers directly. The second route is achieved via e-commerce Websites, such as Amazon and eBay, or catalogue shopping stores such as Agors in the UK where the consumers order the products according to what they see from the product catalogue or samples exhibited, then the products are delivered from the factory to the consumer's home.

The major sustainability issues involved in this phase are the energy consumption and carbon emission during the transportation of the products. It is obvious that the second route is preferable from the sustainability point of view, because it reduces the energy consumption and carbon emission.

**Consumption.** This is the phase of product in service. It is important for the consumers to be encouraged to use the product in a proper way for energy saving and enabling the product in service with its designed life or even longer life. When the product reaches its end of life, the consumer should recycle it, not to throw it to landfill. As presented in Chaps. 5 and 6 of this book, an eco-credit method is developed to encourage the consumer for recycling and an eco-account is established to record the consumer's ecological footprints due to their daily purchasing and recycling products.

**End of product life (EoL).** In this phase, the product's service life terminates. If possible, the EoL product should be disassembled. After disassembling, the EoL product goes in three routes including material for recycling, components for reuse, and disposal. The material for recycling goes back to the manufacture stage and components for reuse goes back to the assembly stage in production phase. The disposal section makes up of landfill, physical, chemical, biological and sustainable treatment, and incineration. Incineration and treatments can produce energy for the whole life cycle to reuse.

### *1.3.2 Objectives of the Sustainable Product Development*

To achieve the sustainability through the product development process, both the inputs and outputs, as shown in Fig. 1.1, should be reduced and various sustainable methods should be applied within the product development process.

The outputs from the whole product life cycle are emission and waste. The emission includes CO<sub>2</sub>, SO<sub>2</sub>, etc. The waste represents any sort of unrecyclable waste.

The inputs to the whole product life cycle include materials, energy, human labour and other resources. To reduce the inputs, the energy and materials have been paid considerable attention in the existing literature; however, the human labour's impact has not been given enough consideration. Because the human labours also produce considerable negative impact, their impact should be considered. To deal with this issue, Su and Ren (2011) developed a method to calculate the human labour's eco-impact, which includes three parts: input (food and drink), output (urine, faeces and respiration) and transportation from home to work place.

### ***1.3.3 A Three-Tiers Approach to Assess Product's Eco-Impact***

In this approach, a product is broken into three tiers: components, subassembly and assembly. Within the production process of a product, related components are assembled together to form a sub-assembly, and then all the sub-assemblies are assembled to form the final product (assembly). The eco-impact elements associated with the production process are relevant to the component and sub-assembly tiers, including impacts of materials used, manufacturing process, packaging, and transportation, as well as human labour and overhead eco-cost. In the assembly tier, the eco-impact elements considered include transportation, packaging, product service life, design for disassembly, product re-use, recycling, and disposal. This approach is further detailed in (Su and Ren 2011), and it has been utilised in the optimisation of sustainable gearbox design presented in Sect. 9.4.1.1 of Chap. 9.

## **1.4 The Integration of Sustainability Methods and Tools for Sustainable Product Development**

The approach is illustrated in Fig. 1.2. Within the approach there are three types of integrations:

**Integration of Methods.** This is to integrate relevant methods into the whole product development process. The methods include the sustainable product design methods presented in Sect. 1.3 above, life cycle impact assessment methods reviewed in Chap. 3, eco-point method detailed in Chap. 5, ICT for eco-accounting infrastructure detailed in Chap. 6, social life cycle assessment presented in Chap. 7, life cycle inventory management methods presented in Chap. 8 and genetic algorithm for sustainable design optimisation presented in Chap. 9. In addition, other existing methods are also included, such as PDS with eco-constraints, LCA procedure, design



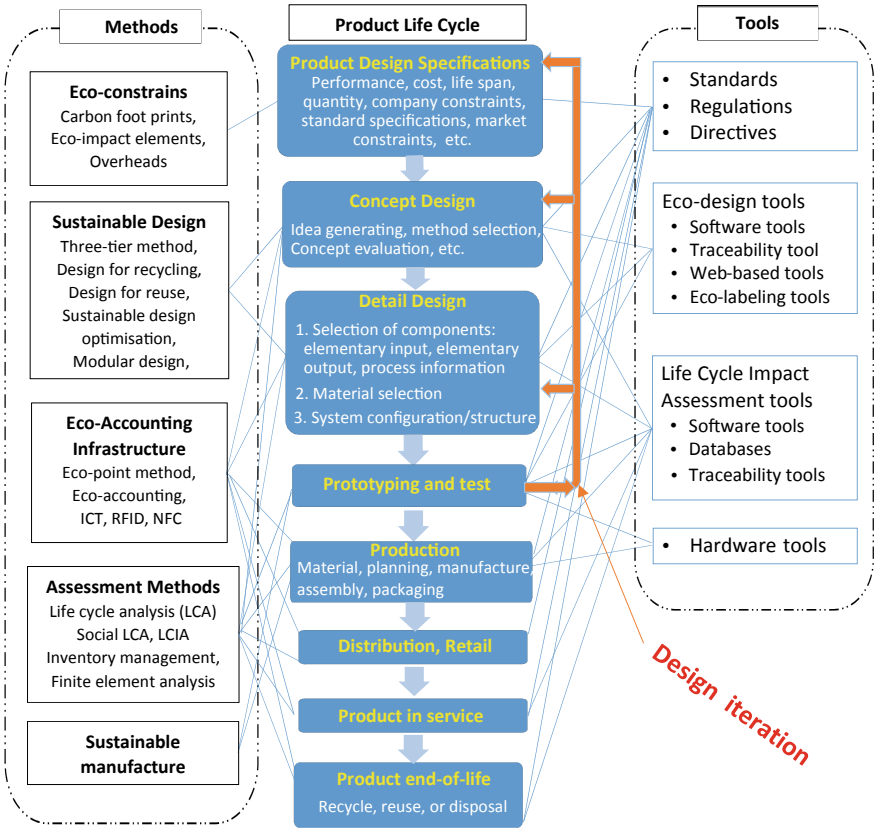

Fig. 1.2 The integrated approach for sustainable product development through product life cycle

for X (design for environment, design for reuse, design for recycling, design for assembly/disassembly, etc.), modular design, finite element analysis and sustainable manufacture.

**Integration of Tools.** This is to Integrate of relevant tools into the whole product development process. The tools include the regulations, directives and standards related to sustainable product development reviewed in Chap. 2, inventory database reviewed in Chap. 3, and life cycle impact assessment software tools reviewed in Chap. 4. Other existing tools related to product development are also considered, such as the tools/equipment for testing the lighting quality of the luminaire mentioned in Chap. 15.

**Integration through Product Life Cycle.** Within the product development process, the product’s sustainability is considered throughout the whole product life cycle, including elaboration of product design specification (PDS), conceptual

design, detail design, prototyping and test, manufacture (material acquisition, manufacturing process, packaging, etc.), transportation, retail, use (product in service), and end-of-life product treatment (recycle, reuse, disposal, etc.).

In the *PDS elaboration phase*, the eco-constraints are derived from various sources such as relevant directives, regulations, eco-design guidelines, standards, etc. These eco-constraints are then integrated into the PDS.

In the *conceptual design phase*, to meet the PDS derived in the previous phase, several design concepts are generated, and then are evaluated against the PDS evaluation criteria. Relevant standards are used to set-up the evaluation criteria. Life Cycle Assessment (LCA) will be conducted during the concept design stage, and, in order to do so, relevant LCIA methods, such as carbon footprint calculation, will be utilized. Because in the conceptual design phase, the product information is not very detailed, unlike the detail design phase, a quick estimation is performed. The eco-points obtained (see Chap. 5 for more information) are used for evaluation of the product concepts. LCIA software for simple and fast analysis, such as Sustainable Minds or SolidWorks (see Chap. 4 for more information), could be more suitable to be used for the analysis.

In the *detail design phase*, the product is further developed from the concept obtained in the conceptual design phase. The major tasks conducted include the selection of components (elementary input, elementary output, process flow, etc.), material selection, and the product system configuration. With further detailed information obtained in detail design, the product's more accurate eco-point score (see Chap. 5 for more information) can be obtained. With the eco-point, the product can be then further optimised to further reduce the product's negative eco-impact. Several software tools are utilized to help select the components and conduct the detail design task. Relevant standards are also referred during this stage of the process to ensure the product quality and to meet the eco-specifications. Relevant sustainable genetic methods are employed to conduct the detailed design, such as application of genetic algorithm design optimisation, modular design, and design for reuse/recycling.

In the *prototyping and testing phase*, the prototype of the product is produced and tested; and the eco-accounting for the product's eco-impact, is conducted and its results are analysed in order to ensure the product to meet the required eco-constraints and the product quality according to the referred standards. Proper testing equipment will be utilized to test the product quality. Unlike the simple/quick LCA conducted in conceptual design phase, a more comprehensive LCA is conducted at this stage. The LCA method and related software tools are utilized to conduct detailed analysis and validation. This is because, in this phase of the product development, the product prototype is completed and hence more detailed information about the product is available. To validate the product's performance, software tool such as finite element analysis package, and hardware tool such as Goniophoto meter for lighting test will be applied in this phase.

In the *production phase*, relevant eco-manufacturing and eco-packaging methods will be applied to reduce waste, material, energy consumption, and impact on the environment. Relevant standards are also followed at this stage to ensure the product quality.

In the *retail phase*, the methods related to eco-shopping, such as eco-account, eco-debits and eco-credits as detailed in Chap. 5 will be utilised to encourage the consumers to reduce their footprints on the environments due to the purchasing.

The data related to the *product in service* phase and treatment of product at the *product end-of-life* phase will be used in the LCA, eco-accounting conducted to assess the product's sustainability.

It has to be pointed out that the tools and methods shown in Fig. 1.2 and discussed above may not all be applied in a particular application. The selection of the tools and methods are depending on the individual cases. The integrated approach for the sustainable product development are illustrated in Chaps. 15 and 16.

## 1.5 Novel Contributions of This Book

This book has the following novel contributions to sustainable product development:

- With an increasing demand for sustainable products, the product designers and manufacturers must comply with the sustainability related directives, regulation and standards, and they need appropriate tools and methods to conduct sustainable product development tasks. However, it is a challenge for them to achieve those. The tools presented in Part I and the methods presented in Part II of this book provide valuable support for the product designers and manufacturers to overcome the challenge.
- The eco-point method presented in this book is a novel contribution to encourage the users to reduce their impact on the environment. The consumer eco-account with eco-debits/credits and eco-balance, and its combination with eco-shopping have not been seen in the literature, and, hence, it is a new and valuable attempt to alert the consumers with their eco-footprints. This method can also be further developed for manufacturers to record their eco-footprints, enabling them to achieve sustainable production.
- The eco-accounting framework enables the implementation of the eco-point approach throughout the process of data collection and processing into the sustainable production assessment, eco-shopping, consumer eco-accounting and recycling/reuse. This a valuable means for both industry and consumers.
- This book also provides several valuable technical contributions, such as
  - The method of integrating multiple tools and methods into the sustainable product development process, which is presented in Sect. 3.3 and illustrated in Chaps. 15 and 16;
  - A novel dynamic data management method, which is presented in this Chapter to track data and monitor each stage of product life cycle, which overcomes the problem of massive data acquisition throughout product supply chain;

- There have been a large number of sustainable product designs, but how to systematically optimise sustainable designs is a still challenge task. The proposed sustainable product design optimisation approach presented in Chap. 8 is a valuable contribution to this subject area.
- The descriptions of each sustainability tool and method are accompanied by easy-to-understand guidelines and examples. The seven case studies presented in this book are real industrial applications, which are valuable illustration for successful application of the sustainability tools and methods into industrial practice.

## 1.6 Concluding Remarks

This chapter gives an overview of this book and highlights the book's novel contributions in the area of sustainable product development.

The scope of sustainable product development is specified, and, in particular, the meanings of the wording 'sustainable' and 'ecological', or 'eco' in short, are discussed and stated that the two words have a similar meaning in this book.

This chapter gives particular attention to two sub-sections '*Sustainable Product Development process*' and '*Integration of sustainability methods and tools*', which are important issues in sustainable product development. The former details with relevant sustainable technologies to be addressed at each stage of a product lifecycle, the objectives to be achieved, and a three-tiers approach; the latter details with various tools and methods, which are presented in the other chapters of this book, could be integrated into the product development process.

## References

- Bhamu, J., & Sangwan, K. S. (2014). Lean manufacturing: Literature review and research issues. *International Journal of Operations & Production Management*, 34(7), 876–940. <https://doi.org/10.1108/IJOPM-08-2012-0315>.
- Byggeth, S., Broman, G., & Robert, K. H. (2007). A method for sustainable product development based on a modular system of guiding questions. *Journal of Cleaner Production*, 15(1), 1–11. <https://doi.org/10.1016/j.jclepro.2006.02.007>.
- Church, T. R. (2014). Back to the drawing board: How good design can eliminate waste, the Guardian. Retrieved September 3, 2014, <https://www.theguardian.com/sustainable-business/2014/sep/03/good-design-eliminate-waste>.
- Donato, J. (n.d.). 'Design Products for Sustainability', British Plastic Foundation, [http://bpf.co.uk/Sustainable\\_Manufacturing/Design/Designing\\_Sustainability.aspx](http://bpf.co.uk/Sustainable_Manufacturing/Design/Designing_Sustainability.aspx).
- European Commission. (2018). Sustainable Product Policy. EU Science Hub, last updated 12 December 2018. Retrieved March 2, 2019, from <https://ec.europa.eu/jrc/en/research-topic/sustainable-product-policy>.

- Geibler J., et al. (n.d.). myEcoCost-Forming the nucleus of a novel environmental accounting system: Vision, prototype and way forward. myEcoCost project brochure. Retrieved October 13, 2018, from <http://myecocost.eu/index.php/project-documents/downloadable-material>.
- Klemes, J. J., Varbanov, P. S., & Huisingh, D. (2012). Recent cleaner production advances in process monitoring and optimisation. *Journal of Cleaner Production*, *34*, 1–8.
- Klöpffer, W. (2003). Life-Cycle based methods for sustainable product development. *The International Journal of Life Cycle Assessment*, *8*, 157. <https://doi.org/10.1007/BF02978462>.
- McAloone, T. C., & Bey, N. (2009). *Environmental improvement through product development: A guide*. Copenhagen: Danish Environmental Protection Agency.
- Moldavska, A., & Welo, T. (2017). The concept of sustainable manufacturing and its definitions: A content-analysis based literature review. *Journal of Cleaner Production*, *166*, 744–755.
- Murray, B. (2013). Embedding environmental sustainability in product design, in Topic Guide, Product Sustainability Forum. Retrieved March October 2, 2019, from <http://www.wrap.org.uk/sites/files/wrap/Embedding%20sustainability%20in%20design%20%20-%20final%20v1.pdf>.
- myEcoCost. (n.d.). myEcoCost-forming the nucleus of a novel ecological accounting system. Retrieved March 2, 2019, from <http://www.myecocost.eu>.
- Sustainable Minds. Retrieved October 5, 2018, from <http://www.sustainableminds.com/>.
- Su, D., & Ren, Z. (2011). Ecological impact assessment and Eco-design of industrial gearboxes, *Key Engineering Materials* (Vol. 486, pp. 197–200). Trans Tech Publications.
- Telenko, C., et. al. (2016). A Compilation of design for environment guidelines. *Journal of Mechanical Design*, *138*(3), ASME, Jan 13, 2016, Paper No: MD-15-1404. <https://doi.org/10.1115/1.403209>.
- Wikipedia. (n.d.). 'Ecodesign', Retrieved March 4, 2019, from <https://en.wikipedia.org/wiki/Ecodesign>.
- World Commission on Environment and Development. (1987). 'Report of the World Commission on Environment and Development: Our Common Future', an Annex to General Assembly document A/42/427-Development and International Co-operation: Environment. UN Documents, August 2, 1987. Retrieved March 4, 2019, from <http://www.un-documents.net/wced-ocf.htm>.

# **Part I**

## **Sustainability Tools**

# Chapter 2

## Review of Directives, Regulations and Standards Related to Sustainable Product Design and Manufacture



Jose L. Casamayor and Daizhong Su

**Abstract** This chapter reviews the main directives, regulations and standards relevant to the design and manufacture of sustainable products. Product designers and manufacturers have to be aware of these, because some of these are mandatory in some countries (e.g. EU countries) and others can contribute significantly to reduce the environmental and social impact of products, thus making the products more sustainable. The chapter begins by providing a general introduction about regulations, directives and standards and their importance. It then continues with a description of the main directives, regulations and standards that are relevant to sustainable design and manufacturing. Finally it is explained how directives, regulations and standards are applied in design and development processes.

**Keywords** Regulations · Directives · Standards · Sustainability · Product design · Manufacture · Eco-design

### 2.1 Introduction

Some directives, regulations and standards can contribute to reduce the environmental and social impact of products, and hence contribute to make the products more sustainable. This chapter will review the existing directives, regulations and standards that, directly or indirectly, contribute to design and manufacture of products in a more sustainable manner.

*Directives* lay down certain results or targets (e.g. reduction of CO<sub>2</sub> levels per year) that must be achieved, but each country affected by these directives is free to

---

J. L. Casamayor (✉)  
Coventry University, Coventry, UK  
e-mail: [ac8335@coventry.ac.uk](mailto:ac8335@coventry.ac.uk)

D. Su  
Advanced Design and Manufacturing Engineering Centre, School of Architecture, Design and the Built Environment, Nottingham Trent University, Nottingham, UK  
e-mail: [daizhong.su@ntu.ac.uk](mailto:daizhong.su@ntu.ac.uk)

decide how to transpose directives into national laws. In the case of sustainability-related directives, these targets are usually related with environmental indicators such as CO<sub>2</sub> levels or waste amount in some countries (USDA 2018).

**Regulations** have binding legal force, and enter into force on a set date in the countries where they apply (USDA 2018).

**Standards** are an agreed way of doing something. It could be about making a product, managing a process, delivering a service or supplying materials. Standards can cover a vast range of activities undertaken by organizations and used by their customers. The point of a standard is to provide a reliable basis for people to share the same expectations about a product or service. This helps to facilitate trade, provide a framework for achieving economies, efficiencies and interoperability and enhance consumer protection and confidence (BSI 2018).

Although directives do not have to be complied by law, they are usually translated into national laws, which have binding legal force, like regulations. However, the adoption and application of standards is voluntary, although they must to be followed to obtain some certifications or sustainable labels.

It is important that manufacturers, and product developers are aware of the regulations and directives applicable to the category of products they develop and produce in different geographical areas (i.e. country), so they can design and manufacture their products to comply with these to avoid fines as well as to reduce their environmental-social impact.

Although standards, are not compulsory, they are required to conduct tests to obtain certain certifications (i.e. eco-labels, quality labels), so they can, indirectly, contribute to reduce the environmental-social impact of products too.

In the following sections, the directives and regulations which have been created to reduce the environmental and social impacts of products and the standards that can directly or indirectly contribute to reduce the environmental impact of products are discussed.

## 2.2 Directives

Nine directives are reviewed in this section (Table 2.1), which are related to the areas of energy consumption, waste, recycle/reuse, restriction of hazardous substances, pollutant emissions and environmental impact assessment. Each directive's related key areas are listed in the Table 2.1, while more detailed information of the directives is presented after the table.

### 2.2.1 Energy Labelling Directive 2010/30/EU (EC 2010b)

The Energy Labelling Directive (2010/30/EC) establishes a framework for labelling and consumer information regarding energy consumption. Initially established for



**Table 2.1** List of directives

Directives	Related key areas
(1) Energy labelling directive 2010/30/EU (EC 2010b)	Energy consumption
(2) Energy-related Products (ErP) Directive 2009/125/EC (EC, 2009a, b)	Energy consumption
(3) Eco-design directive 2009/125/EC (EC 2009a, b)	Energy consumption, waste, recycle/reuse
(4) Waste Electrical and Electronic Equipment recycling (WEEE) directive 2012/19/EC (EC 2012a, b)	Waste, recycle/reuse of electronic products/equipment
(5) Waste Framework Directive 2008/98/EC (EC 2008)	Waste, recycle/reuse
(6) Restriction of Hazardous Substances (RoHS) directive 2011/65/EC (EC 2011)	Restriction to use hazardous substances in products
(7) Packaging and Packaging waste directive 94/62/EC (EC 1994)	Packaging, recycle/reuse, waste
(8) Industrial Emissions Directive (IED) Directive 2010/75/EU (EC 2010a)	Regulating industrial pollutant emissions
(9) Environmental Impact Assessment (EIA) Directive 2014/52/EC (EC 1985)	Environmental impact assessment framework

household appliances, the scope of the Directive has been extended to energy-related products, which are likely to have a direct or indirect impact on the consumption of energy and potentially of other resources during use.

The Energy Labelling Directive is a framework directive that mandates the Commission to propose, by means of delegated acts, details relating to information to be provided on the label and in the fiche for each type of product. Products are ranked, according to their energy consumption, on an A to G scale with colours from dark green to red. The implementation of the Energy Labelling Directive is linked to the Eco-design Directive (2009/125/EC). Requirements and benchmarks defined for individual product groups under the Eco-design Directive are used as references for setting the energy labelling classes.

### **2.2.2 Energy-Related Products (ErP) Directive 2009/125/EC (EC 2009a, b)**

The aim of this directive is to improve energy efficiency and environmental protection, it applies to products that affect energy consumption throughout their life cycle.

This directive does not introduce directly binding requirements for specific product categories, but rather outlines the conditions and criteria relating to environmental

characteristics of products, such as energy and water waste, or lifespan, so they can be improved quickly and efficiently. It encourages manufacturers and/or importers to offer products designed to reduce their overall impact on the environment, including the resources consumed during manufacture and disposal.

It applies to energy-related products that meet the following criteria: Are sold in high quantities (over 200,000 units/year in the EU), have a significant environmental impact and have a potential for improvement.

### ***2.2.3 Eco-design Directive 2009/125/EC (EC 2009a, b)***

The aim of the Eco-design Directive is to reduce (at the design stage) the energy consumption and other negative environmental impacts of products. Although the primary aim is to reduce energy use, it is also aimed to consider other factors that may influence the environmental impact of the product such as: Materials use, water use, polluting emissions, waste issues and recyclability.

### ***2.2.4 Waste Electrical and Electronic Equipment Recycling (WEEE) Directive 2012/19/EC (EC 2012a, b)***

The WEEE directive requires producers and distributors to finance the collection, treatment and recycling or reuse of Electrical and Electronic Equipment.

The aim of this directive is to address the environmental impact of WEEE and to encourage its separate collection and subsequent treatment, reuse, recovery, recycling and environmentally sound disposal.

It affects any importer, re-brander or manufacturer of products that requires electricity for its main purpose. These will have to finance the cost of: Collecting, treating (e.g.: mercury in lamps, Printed Circuit Board (PCB) in ballasts), recovering and recycling products imported, re-branded or manufactured. For these purposes all these products should be marked.

### ***2.2.5 Waste Framework Directive 2008/98/EC (EC 2008)***

It builds a legal framework for treating waste in the EU. It sets the basic concepts and definitions related to waste management, such as definitions of waste, recycling, recovery. It explains when waste ceases to be waste and becomes a secondary raw material (so called end-of-waste criteria), and how to distinguish between waste and by-products. The Directive lays down some basic waste management principles: it requires that waste be managed without endangering human health and harming

the environment, and in particular without risk to water, air, soil, plants or animals, without causing a nuisance through noise or odours, and without adversely affecting the countryside or places of special interest. Waste legislation and policy of the EU Member States shall apply as a priority order the following waste management hierarchy: (1) Prevention (non-waste), (2) re-use of waste, (3) recycling of waste, (4) recovery of waste, and (5) disposal of waste.

This directive introduces the ‘polluter pays principle’ and the ‘extended producer responsibility’. It incorporates provisions on hazardous waste and waste oils and includes two new recycling and recovery targets to be achieved by 2020: 50% preparing for re-use and recycling of certain waste materials from households and other origins similar to households, and 70% preparing for re-use, recycling and other recovery of construction and demolition waste. The Directive requires that Member States adopt waste management plans and waste prevention programmes.

### ***2.2.6 Restriction of Hazardous Substances (RoHS) Directive 2011/65/EC (EC 2011)***

This directive prevents all new electrical and electronic equipment placed on the market in the European Economic Area from containing lead, mercury, cadmium, hexavalent chromium, poly-brominated biphenyls (PBB) or polybrominated diphenyl ethers (PBDE), except in certain specific applications, in concentrations greater than the values decided by the European Commission. These values have been established as 0.01% by weight per homogeneous material for cadmium and 0.1% for the other five substances.

It draws its scope of application from that of the Waste Electrical and Electronic Equipment (WEEE) Directive, with a few exceptions. The WEEE Directive specifies ten broad product categories: (1) Large household appliances, (2) Small household appliances, (3) IT and telecommunications equipment, (4) Consumer equipment, (5) Lighting equipment, (6) Electrical and electronic tools (with the exception of large-scale stationary industrial tools), (7) Toys, leisure and sports equipment, (8) Medical devices (with the exception of all implanted and infected products), (9) Monitoring and control instruments, and (10) Automatic dispensers. Groups 8 and 9 were not within scope of the RoHS 1 but are being included within the scope of RoHS 2, these will be phased in completely by 2019. Also ‘Light bulbs and luminaries in households’ have been included in the scope of the RoHS Directive, although they are not within the scope of the WEEE Directive.

### **2.2.7 *Packaging and Packaging Waste Directive 94/62/EC (EC 1994)***

This directive affects any type of product that uses any type (primary/secondary) of packaging. Its main objectives are: Reduce packaging material excess, eliminate/avoid specific hazardous substances/materials, inform the consumers about the content of product/packaging, reduce the amount of waste at end of life of the packaging, increase/promote the re-use and recycle of packaging waste and inform the producer/manufacturer about their responsibility to recuperate and recycle its packaging.

### **2.2.8 *Industrial Emissions Directive (IED) Directive 2010/75/EU (EC 2010a)***

This directive aims to achieve a high level of protection of human health and the environment taken as a whole by reducing harmful industrial emissions across the EU, in particular through better application of Best Available Techniques (BAT). It is the main EU instrument regulating pollutant emissions. IED is based on several pillars: (1) an integrated approach, (2) use of best available techniques, (3) flexibility, (4) inspections and (5) public participation.

- (1) The integrated approach means that the permits must take into account the whole environmental performance of the plant, covering: emissions to air, water and land, generation of waste, use of raw materials, energy efficiency, noise, prevention of accidents, and restoration of the site upon closure.
- (2) The permit conditions including emission limit values must be based on the Best Available Techniques (BAT). In order to define BAT and the BAT-associated environmental performance at EU level, the Commission organises an exchange of information with experts from Member States, industry and environmental organisations. This work is co-ordinated by the European IPPC Bureau of the Institute for Prospective Technology Studies at the EU Joint Research Centre in Seville (Spain). This process results in BAT Reference Documents (BREFs); the BAT conclusions contained are adopted by the Commission as Implementing Decisions. The IED requires that these BAT conclusions are the reference for setting permit conditions.
- (3) The IED allows competent authorities some flexibility to set less strict emission limit values. This is possible only in specific cases where an assessment shows that achieving the emission levels associated with BAT described in the BAT conclusions would lead to disproportionately higher costs compared to the environmental benefits due to the geographical location or the local environmental conditions or the technical characteristics of the installation.

- (4) The IED contains mandatory requirements on environmental inspections. Member States shall set up a system of environmental inspections and draw up inspection plans accordingly. The IED requires a site visit to take place at least every 1 to 3 years, using risk-based criteria.
- (5) The IED ensures that the public has a right to participate in the decision-making process, and to be informed of its consequences, by having access to permit applications, permits and the results of the monitoring of releases.

### **2.2.9 *Environmental Impact Assessment (EIA) Directive 2014/52/EC (EC 1985)***

This directive is in force since 1985 and applies to a wide range of defined public and private projects, which are defined in Annexes I and II. Its objective is to simplify the procedures for assessing environmental impact, define timeframes for the different stages of environmental assessment, and improve the quality, transparency of EIA reports. All projects listed in Annex I are considered as having significant effects on the environment and require an EIA (e.g. long-distance railway lines, motorways and express roads, airports with a basic runway length  $\geq 2100$  m, installations for the disposal of hazardous waste, installations for the disposal of non-hazardous waste  $>100$  tonnes/day, waste water treatment plants  $>150.000$  p.e.), and therefore are considered as mandatory EIA.

For projects listed in Annex II, the national authorities have to decide whether an EIA is needed (i.e. the need of an EIA is decided at discretion of Member States). This is done by the 'screening procedure', which determines the effects of projects on the basis of thresholds/criteria or a case by case examination. However, the national authorities must take into account the criteria laid down in Annex III. The projects listed in Annex II are in general those not included in Annex I (i.e. railways, roads waste disposal installations, waste water treatment plants), but also other types such as urban development projects, flood-relief works.

## **2.3 Regulations**

This section reviews two regulations, which are related to 'Eco-Management and Audit Scheme' and 'Eco-Labels'.

### **2.3.1 *Eco-Management and Audit Scheme Regulation (EMAS) (EC) No 1221/2009 (EC 2009c)***

It is a management instrument developed by the European Commission for companies and other organisations to evaluate, report, and improve their environmental performance. EMAS is open to every type of organisation eager to improve its environmental performance. It spans all economic and service sectors and is applicable worldwide.

EMAS supports organisations in finding the right tools to improve their environmental performance. The organisations that voluntarily participate, commit to, both evaluating and reducing, their environmental impact. Third party verification guarantees the external and independent nature of the EMAS registration process. Providing publicly available information on an organisation's environmental performance is an important aspect of EMAS. Organisations achieve greater transparency both externally, through the environmental statement, and internally through employees' active involvement.

EMAS can help to reduce the environmental impact of the company, strengthen legal compliance and employee involvement, and save resources and money. The key benefits of EMAS are: (1) Enhanced credibility, transparency and reputation, (2) Enhanced environmental risks and opportunities management, (3) Enhanced environmental and financial performance, and (4) Enhanced employee empowerment and motivation.

### **2.3.2 *Eco-Label Regulation (EC) No 66/2010 (EC 2010c)***

It concerns the European Union (EU) Ecolabel which is a voluntary environmental labelling scheme.

It enables consumers, by means of transparent ecological criteria, to make conscious choices without compromising on the quality of the products.

It may be awarded to products and services which have a lower environmental impact than other products in the same group. The label criteria were devised using scientific data on the whole of a product's life cycle, from product development to disposal. The label is awarded in consideration of European environmental and ethical objectives. It also promotes the EU's transition to a circular economy, supporting both sustainable production and consumption.

The label may be awarded to all goods or services distributed, consumed or used on the EU market whether in return for payment or free of charge, on condition that the ecological criteria have been clearly established. It does not apply to medicinal products for human or veterinary use, or to medical devices.

The system was introduced by Regulation (EEC) No 880/92 and amended by Regulation (EC) No 1980/2000. This Regulation (EC) No 66/2010 aims to improve the rules on the award, use and operation of the label.

## 2.4 Standards

Two types of standards, IEC and ISO, are reviewed in this section. The former is about design for electrical and electronic products, while the latter consists of 25 standards, including four standards regarding environmental management systems, five standards regarding environmental labels and declarations, 12 standards related to specific topics of environmental management, and four standards about greenhouse gases. The standards are listed in Table 2.2 and further reviewed in this section after the table.

### 2.4.1 *IEC 62430:2009 Standard of ‘Environmentally Conscious Design for Electrical and Electronic Products’ (IEC 2009)*

It applies to all the electrical/electronic products. This international standard provides a set of requirements for the process of environmentally conscious design reflecting the contents of IEC Guide 114 and ISO/TR 14062. This International Standard is intended for use by all those involved in the design and development of electrical and electronic products. To ensure consistency throughout the electro-technical sector the use of this standard as a base reference is encouraged.

### 2.4.2 *The ISO 14000 Family of ‘Environmental Management’ Related Standards*

The standards of this family provide practical tools for companies and organizations of all kinds looking to manage their environmental responsibilities, facilitating sustainable product design and manufacturing. 25 standards are reviewed within this family, which are grouped into four groups: four standards of Environmental management systems, five standards of environmental labels and declarations, 12 standards of environmental management specific topics, and four standards of greenhouse gases, as further detailed below.

#### 2.4.2.1 Environmental Management Systems

This group of four standards cover the following aspects: Requirements with guidance for use, general guidelines on implementation, guidelines for the phased implementation of an environmental management system, and guidelines for incorporating eco-design.

**Table 2.2** List of standards

<b>2.4.1 IEC standard</b>	
IEC 62430:2009	Environmentally conscious design for electrical and electronic products
<b>2.4.2 ISO 14000 Standards ‘Environmental Management’</b>	
<i>2.4.2.1 Environmental management systems</i>	
ISO 14001:2015	Environmental management systems: Requirements with guidance for use
ISO 14004:2016	Environmental management systems: General guidelines on implementation
ISO 14005:2010	Environmental management systems: Guidelines for the phased implementation of an environmental management system, including the use of environmental performance evaluation
ISO 14006:2011	Environmental management systems: Guidelines for incorporating eco-design
<i>2.4.2.2 Environmental labels and declarations</i>	
ISO 14020:2000	Environmental labels and declarations: General principles
ISO 14021:2016	Environmental labels and declarations: Self-declared environmental claims (Type II environmental labelling)
ISO 14024:2018	Environmental labels and declarations: Type I environmental labelling: Principles and procedures
ISO 14025:2006	Environmental labels and declarations: Type III environmental declarations: Principles and procedures
ISO 14026:2017	Environmental labels and declarations: Principles, requirements and guidelines for communication of footprint information
<i>2.4.2.3 Environmental management</i>	
(1) Standards of miscellaneous topics related to environmental management	
ISO 14031:2013	Environmental management: Environmental performance evaluation: Guidelines
ISO/TS 4033:2012	Environmental management: Quantitative environmental information: Guidelines and examples
ISO 14034:2016	Environmental management: Environmental technology verification (ETV)
ISO 14063:2006	Environmental management: Environmental communication: Guidelines and examples
ISO 14045:2012	Environmental management: Eco-efficiency assessment of product systems: Principles, requirements and guidelines
(2) Water footprints	
ISO 14046:2014	Environmental management: Water footprint: Principles, requirements and guidelines
ISO/TR 14073:2017	Environmental management: Water footprint: Illustrative examples on how to apply ISO 14046

(continued)



**Table 2.2** (continued)

(3) Life cycle assessment	
ISO 14044:2006	Environmental management: Life cycle assessment: Requirements and guidelines
ISO/TR 14047:2012	Environmental management: Life cycle assessment: Illustrative examples on how to apply ISO 14044 to impact assessment situations
ISO/TS 14048:2002	Environmental management: Life cycle assessment: Data documentation format
ISO/TR 14049:2012	Environmental management: Life cycle assessment: Illustrative examples on how to apply ISO 14044 to goal and scope definition and inventory analysis
ISO/TS 14072:2014	Environmental management: Life cycle assessment: Requirements and guidelines for organizational life cycle assessment
2.4.2.4 Greenhouse gases	
ISO 14064-1:2006	Greenhouse gases: Part 1: Specification with guidance at the organization level for quantification and reporting of greenhouse gas emissions and removals
ISO 14064-2:2006	Greenhouse gases: Part 2: Specification with guidance at the project level for quantification, monitoring and reporting of greenhouse gas emission reductions or removal enhancements
ISO/TS 14067:2013	Greenhouse gases: Carbon footprint of products: Requirements and guidelines for quantification and communication
ISO/TR 14069:2013	Greenhouse gases: Quantification and reporting of greenhouse gas emissions for organizations: Guidance for the application of ISO 14064-1

- *ISO 14001:2015—Environmental management systems: Requirements with guidance for use (ISO 2015)*:

It specifies the requirements for an environmental management system that an organization can use to enhance its environmental performance. It is intended for use by an organization seeking to manage its environmental responsibilities in a systematic manner that contributes to the environmental pillar of sustainability. It helps an organization achieve the intended outcomes of its environmental management system, which provide value for the environment, the organization itself and interested parties. Consistent with the organization's environmental policy, the intended outcomes of an environmental management system include: (1) enhancement of environmental performance, (2) fulfilment of compliance obligations, and (3) achievement of environmental objectives.

This standard is applicable to any organization, regardless of size, type and nature, and applies to the environmental aspects of its activities, products and services that the organization determines it can either control or influence considering a life cycle perspective. However, this standard does not state specific environmental performance criteria. This standard can be used in whole or in part to systematically improve environmental management.

- *ISO 14004:2016—Environmental management systems: General guidelines on implementation (ISO 2016a):*

It provides guidance for an organization on the establishment, implementation, maintenance and improvement of a robust, credible and reliable environmental management system. The guidance provided is intended for an organization seeking to manage its environmental responsibilities in a systematic manner that contributes to the environmental pillar of sustainability. The guidance in this International Standard can help an organization to enhance its environmental performance and enables the elements of the environmental management system to be integrated into its core business process.

This standard is applicable to any organization, regardless of size, type and nature, and applies to the environmental aspects of its activities, products and services that the organization determines it can either control or influence, considering a life cycle perspective.

The guidance in this International Standard can be used in whole or in part to systematically improve environmental management. It serves to provide additional explanation of the concepts and requirements.

- *ISO 14005:2010—Environmental management systems: Guidelines for the phased implementation of an environmental management system, including the use of environmental performance evaluation (ISO 2010):*

It provides guidance for all organizations, but particularly small and medium-sized enterprises, on the phased development, implementation, maintenance and improvement of an environmental management system. It also includes advice on the integration and use of environmental performance evaluation techniques.

It is applicable to any organization, regardless of its level of development, the nature of the activities undertaken or the location at which they occur.

- *ISO 14006:2011—Environmental management systems: Guidelines for incorporating eco-design (ISO 2011):*

It provides guidelines to assist organizations in establishing, documenting, implementing, maintaining and continually improving their management of eco-design as part of an environmental management system (EMS). It is intended to be used by those organizations that have implemented an EMS in accordance with ISO 14001, but can help in integrating eco-design in other management systems.

It is applicable to any organization, regardless of size, type and nature, and applies to the environmental aspects of its activities, products and services that the organization determines it can either control or influence considering a life cycle perspective. However, it does not state specific environmental performance criteria and is not intended for certification purposes. It can be used in whole or in part to systematically improve environmental management. Claims of conformity to ISO 14001:2015, however, are not acceptable unless all its requirements are incorporated into an organization's environmental management system and fulfilled without exclusion.

### 2.4.2.2 Environmental Labels and Declarations

This group of five standards cover the following aspects: General principles, Self-declared environmental claims (Type II environmental labelling), Types I and III environmental labelling (Principles and procedures), and Principles, requirements and guidelines for communication of footprint information, with further information presented below:

- *ISO 14020:2000—Environmental labels and declarations: General principles (ISO 2000):*

This International Standard establishes guiding principles for the development and use of environmental labels and declarations. It is intended that other applicable standards in the ISO 14020 series be used in conjunction with this International Standard. This International Standard is not intended for use as a specification for certification and registration purposes.

- *ISO 14021:2016—Environmental labels and declarations: Self-declared environmental claims (Type II environmental labelling) (ISO 2016b):*

This standard specifies requirements for self-declared environmental claims (Type II environmental labels), including statements, symbols and graphics, regarding products. It further describes selected terms commonly used in environmental claims and gives qualifications for their use. It also describes a general evaluation and verification methodology for self-declared environmental claims and specific evaluation and verification methods for the selected claims in this international standard. It does not preclude, override, or in any way change, legally required environmental information, claims or labelling, or any other applicable legal requirements.

- *ISO 14024:2018—Environmental labels and declarations: Type I environmental labelling: Principles and procedures (ISO 2018):*

It establishes the principles and procedures for developing Type I environmental labelling programmes, including the selection of product categories, product environmental criteria and product function characteristics, and for assessing and demonstrating compliance. It also establishes the certification procedures for awarding the label.

- *ISO 14025:2006—Environmental labels and declarations: Type III environmental declarations: Principles and procedures (ISO 2006a):*

It establishes the principles and specifies the procedures for developing Type III environmental declaration programmes and Type III environmental declarations. It specifically establishes the use of the ISO 14040 series of standards in the development of Type III environmental declaration programmes and Type III environmental declarations.

This standard establishes principles for the use of environmental information, in addition to those given in ISO 14020:2000.

Type III environmental declarations as described in this standard are primarily intended for use in business-to-business communication, but their use in business-to-consumer communication under certain conditions is not precluded.

- *ISO 14026:2017—Environmental labels and declarations: Principles, requirements and guidelines for communication of footprint information (ISO 2017a):*

It provides principles, requirements and guidelines for footprint communications for products addressing areas of concern relating to the environment. It also provides requirements and guidelines for footprint communication programmes, as well as requirements for verification procedures. It does not address the quantification of a footprint, nor does it address the communication of footprints that are not related to the environment, e.g. footprints addressing social or economic issues. In particular, footprint communications relating to the economic and social dimensions of sustainable development are outside the scope of this standard. Footprint communications relating to organizations are also outside the scope of this standard.

### 2.4.2.3 Environmental Management

This group of standards are reviewed in three sub-groups: (1) five standards of miscellaneous topics which cover ‘Environmental performance evaluation: Guidelines’, ‘Quantitative environmental information: Guidelines and examples’, ‘Environmental technology verification’, ‘Environmental communication: Guidelines and examples’, and ‘Eco-efficiency assessment of product systems: Principles, requirements and guidelines’; (2) two standard about water footprint, including ‘Illustrative examples on how to apply ISO 14046’ and ‘Principles, requirements and guidelines’; and (3) five standards of lifecycle assessment covering the following aspects: ‘Principles and framework’, ‘Requirements and guidelines’, ‘Data documentation format’, ‘Illustrative examples on how to apply ISO 14044 to impact assessment situations’, ‘Illustrative examples on how to apply ISO 14044 to goal and scope definition and inventory analysis, and ‘Requirements and guidelines for organizational life cycle assessment’. Further information of the standard is presented below.

#### (1) *Standards of miscellaneous topics related to environmental management*

- *ISO 14031:2013—Environmental management: Environmental performance evaluation: Guidelines (ISO 2013a):*

It gives guidance on the design and use of Environmental Performance Evaluation (EPE) within an organization. It is applicable to all organizations, regardless of type, size, location and complexity.

It does not establish environmental performance levels.

The guidance in this standard can be used to support an organization’s own approach to EPE, including its commitments to compliance with legal and other requirements, the prevention of pollution, and continual improvement.

- *ISO/TS 14033:2012—Environmental management: Quantitative environmental information: Guidelines and examples (ISO 2012a):*

It provides guidelines on how to acquire quantitative environmental information and data and implement methodology. It gives guidelines to organizations on general principles, policy, strategy and activities necessary to obtain quantitative environmental information for internal and/or external purposes. Such purposes can be, for example, to establish inventory routines and support decision-making related to environmental policies and strategies, aimed in particular at comparing quantitative environmental information. The information is related to organizations, activities, facilities, technologies or products.

It addresses issues related to defining, collecting, processing, interpreting and presenting quantitative environmental information. It provides guidelines on how to establish accuracy, verifiability and reliability for the intended use. It utilizes proven and well-established approaches for the preparation of information adapted to the specific needs of environmental management. It is applicable to all organizations, regardless of their size, type, location, structure, activities, products, level of development and whether or not they have an environmental management system in place.

It supplements the contents of other International Standards on environmental management.

- *ISO 14034:2016—Environmental management: Environmental technology verification (ETV) (ISO 2016c):*

The objective of Environmental Technology Verification (ETV) is to provide credible, reliable and independent verification of the performance of environmental technologies. An environmental technology is a technology that either results in an environmental added value or measures parameters that indicate an environmental impact. Such technologies have an increasingly important role in addressing environmental challenges and achieving sustainable development.

ETV contributes to protection and conservation of the environment by promoting and facilitating market uptake of innovative environmental technologies, especially those that perform better than relevant alternatives. ETV is particularly applicable to those environmental technologies whose innovative features or performance cannot be fully assessed using existing standards. Through the provision of objective evidence, ETV provides an independent and impartial confirmation of the performance of an environmental technology based on reliable test data. ETV aims to strengthen the credibility of new, innovative technologies by supporting informed decision-making among interested parties.

- *ISO 14063:2006—Environmental management: Environmental communication: Guidelines and examples (ISO 2006b):*

It gives guidance to an organization on general principles, policy, strategy and activities relating to both internal and external environmental communication. It

utilizes proven and well-established approaches for communication, adapted to the specific conditions that exist in environmental communication. It is applicable to all organizations regardless of their size, type, location, structure, activities, products and services, and whether or not they have an environmental management system in place.

It is not intended for use as a specification standard for certification or registration purposes or for the establishment of any other environmental management system conformity requirements. It can be used in combination with any of the ISO 14000 series of standards, or on its own.

- *ISO 14045:2012—Environmental management: Eco-efficiency assessment of product systems: Principles, requirements and guidelines (ISO 2012b):*

It describes the principles, requirements and guidelines for eco-efficiency assessment for product systems including: (1) the goal and scope definition of the eco-efficiency assessment, (2) the environmental assessment, (3) the product-system-value assessment, (4) the quantification of eco-efficiency, (5) interpretation (including quality assurance), (6) reporting, and (7) critical review of the eco-efficiency assessment.

Requirements, recommendations and guidelines for specific choices of categories of environmental impact and values are not included. The intended application of the eco-efficiency assessment is considered during the goal and scope definition phase, but the actual use of the results is outside the scope of this standard.

## (2) *Water footprints*

- *ISO 14046:2014—Environmental management: Water footprint: Principles, requirements and guidelines (ISO 2014a):*

It specifies principles, requirements and guidelines related to water footprint assessment of products, processes and organizations based on LCA.

It provides principles, requirements and guidelines for conducting and reporting a water footprint assessment as a stand-alone assessment, or as part of a more comprehensive environmental assessment. Only air and soil emissions that impact water quality are included in the assessment, and not all air and soil emissions are included.

Whereas reporting is within the scope of this standard, communication of water footprint results, for example in the form of labels or declarations, is outside the scope of the standard.

- *ISO/TR 14073:2017—Environmental management: Water footprint: Illustrative examples on how to apply ISO 14046 (ISO 2017b):*

It provides illustrative examples of how to apply ISO 14046, in order to assess the water footprint of products, processes and organizations based on life cycle assessment.

The examples are presented to demonstrate particular aspects of the application of ISO 14046 and therefore do not present all of the details of an entire water footprint study report as required by ISO 14046.

(3) *Life cycle assessment*

- *ISO 14044:2006—Environmental management: Life cycle assessment: Requirements and guidelines (ISO 2006c):*

It specifies requirements and provides guidelines for Life Cycle Assessment (LCA) including: definition of the goal and scope of the LCA, the life cycle inventory analysis (LCI) phase, the life cycle impact assessment (LCIA) phase, the life cycle interpretation phase, reporting and critical review of the LCA, limitations of the LCA, relationship between the LCA phases, and conditions for use of value choices and optional elements. It covers LCA studies and LCI studies.

- *ISO/TR 14047:2012—Environmental management: Life cycle assessment: Illustrative examples on how to apply ISO 14044 to impact assessment situations (ISO 2012c):*

The purpose of this standard is to provide examples to illustrate current practice of life cycle impact assessment according to ISO 14044:2006. These examples are only a sample of all possible examples that could satisfy the provisions of ISO 14044. They offer “a way” or “ways” rather than the “unique way” of applying ISO 14044. They reflect the key elements of the life cycle impact assessment (LCIA) phase of the LCA. The examples presented in this standard are not exclusive and other examples exist to illustrate the methodological issues described.

- *ISO/TS 14048:2002—Environmental management: Life cycle assessment: Data documentation format (ISO 2002):*

This Technical Specification provides the requirements and a structure for a data documentation format, to be used for transparent and unambiguous documentation and exchange of LCA and LCI data, thus permitting consistent documentation of data, reporting of data collection, data calculation and data quality, by specifying and structuring relevant information.

The data documentation format specifies requirements on division of data documentation into data fields, each with an explanatory description. The description of each data field is further specified by the structure of the data documentation format. This Technical Specification is applicable to the specification and structuring of questionnaire forms and information systems. However, it can also be applied to other aspects of the management of environmental data. It does not include requirements on completeness of data documentation. The data documentation format is independent of any software or database platform for implementation.

This Technical Specification does not require any specific sequential, graphic or procedural solutions for the presentation or treatment of data, nor does it describe specific modelling methodologies for LCI and LCA data.

- *ISO/TR 14049:2012—Environmental management: Life cycle assessment: Illustrative examples on how to apply ISO 14044 to goal and scope definition and inventory analysis (ISO 2012d):*

It provides examples about practices in carrying out a LCI as a means of satisfying certain provisions of ISO 14044:2006. These examples are only a sample of the possible cases satisfying the provisions of ISO 14044. They offer “a way” or “ways” rather than the “unique way” for the application of ISO 14044. These examples reflect only portions of a complete LCI study.

- *ISO/TS 14072:2014—Environmental management: Life cycle assessment: Requirements and guidelines for organizational life cycle assessment (ISO 2014b):*

It provides additional requirements and guidelines for an effective application of ISO 14040 and ISO 14044 to organizations. It provides guidelines about: (1) the application of LCA principles and methodology to organizations, (2) the benefits that LCA can bring to organizations by using LCA methodology at organizational level, (3) the system boundary, (4) specific considerations when dealing with LCI, LCIA, and interpretation, and (5) the limitations regarding reporting, environmental declarations, and comparative assertions.

This standard applies to any organization that has interest in applying LCA. It specifically covers the goals of ISO 14040 and ISO 14044.

#### **2.4.2.4 Greenhouse Gases**

This group of standards cover the following aspects: ‘Part 1: Specification with guidance at the organization level for quantification and reporting of greenhouse gas emissions and removals’, ‘Part 2: Specification with guidance at the project level for quantification, monitoring and reporting of greenhouse gas emission reductions or removal enhancements’, ‘Carbon footprint of products: Requirements and guidelines for quantification and communication’, and ‘Quantification and reporting of greenhouse gas emissions for organizations: Guidance for the application of ISO 14064-1’, with further information presented below.

- *ISO 14064-1:2006—Greenhouse gases: Part 1: Specification with guidance at the organization level for quantification and reporting of greenhouse gas emissions and removals (ISO 2006e):*



It specifies principles and requirements at the organization level for quantification and reporting of GreenHouse Gas (GHG) emissions and removals. It includes requirements for the design, development, management, reporting and verification of an organization's GHG inventory.

- *ISO 14064-2:2006 Greenhouse gases: Part 2: Specification with guidance at the project level for quantification, monitoring and reporting of greenhouse gas emission reductions or removal enhancements (ISO 2006e):*

It specifies principles and requirements and provides guidance at the project level for quantification, monitoring and reporting of activities intended to cause GHG emission reductions or removal enhancements. It includes requirements for planning a GHG project, identifying and selecting GHG sources, sinks and reservoirs relevant to the project and baseline scenario, monitoring, quantifying, documenting and reporting GHG project performance and managing data quality.

- *ISO/TS 14067:2013—Greenhouse gases: Carbon footprint of products: Requirements and guidelines for quantification and communication (ISO 2013b):*

It specifies principles, requirements and guidelines for the quantification and communication of the Carbon FootPrint of a product (CFP), based on International Standards on life cycle assessment (ISO 14040 and ISO 14044) for quantification and on environmental labels and declarations (ISO 14020, ISO 14024 and ISO 14025) for communication.

This standard is applicable to CFP studies and different options for CFP communication based on the results of such studies.

This standard also provides for the development of CFP-Product Category Rules (CFP-PCR), or the adoption of PCR that have been developed in accordance with ISO 14025 and that are consistent with ISO/TS 14067:2013. This standard only addresses one impact category: climate change.

- *ISO/TR 14069:2013—Greenhouse gases: Quantification and reporting of greenhouse gas emissions for organizations: Guidance for the application of ISO 14064-1 (ISO 2013c):*

It describes the principles, concepts and methods relating to the quantification and reporting of direct and indirect GHG emissions for an organization. It provides guidance for the application of ISO 14064-1 to greenhouse gas inventories at the organization level, for the quantification and reporting of direct emissions, energy indirect emissions and other indirect emissions.

It describes for all type of organizations, including local authorities, the steps for: (1) establishing organizational boundaries, in accordance with either a control approach (financial or operational) or an equity share approach, (2) establishing operational boundaries, by identifying direct emissions and energy indirect emissions to be quantified and reported, as well as any other indirect emissions the organization chooses to quantify and report; for each category of emission, guidance is provided on specific boundaries and methodologies for the quantification of GHG emissions and removals, (3) GHG reporting: guidance is provided to promote transparency

regarding the boundaries, the methodologies used for the quantification of direct and indirect GHG emissions and removals, and the uncertainty of the results.

## **2.5 Application of Directives, Regulations and Standards in Sustainable Product Design and Manufacture**

Regulations, directives and standards can be applied in design and manufacturing processes to comply with environmental legislation and/or reduce the environmental and social impact of products. However, all these tools have different purposes and are applied differently during the design and manufacturing process.

Regulations and directives usually prescribe design recommendations which have to be taken into account during the design process. For example, the Energy-related Products (ErP) Directive 2009/125/EC (European Commission 2009a, b) provide general recommendations about how to improve the energy efficiency of energy-using products throughout their life cycle. These design guidelines/recommendations have to be included at the beginning of the design process, during the ‘product design specifications’ stage, so they can be considered during the definition of the initial concept of the product. Another example is the Restriction of Hazardous Substances (RoHS) directive which bans the utilisation of specific amounts of certain hazardous substances in products. This recommendation also has to be taken into account during the material selection stage of the design process.

The application of standards is not compulsory during the design and manufacturing processes. However, some tests and certifications oblige to follow certain standards to be valid and be recognised in industry. For example, standards provide the protocols and procedures used to carry out the tests which are necessary to improve the reliability of the product, to obtain a certification (e.g. CE mark, IP test), or to conduct a performance assessment (e.g. energy consumption assessment).

## **2.6 Concluding Remarks**

After giving brief definitions of the three terms ‘directives’, ‘regulations’ and ‘standards’, the authors reviewed nine directives, two regulations and 26 standards related to the design and manufacture of sustainable products.

With the increasing demands for sustainable products, product designers and manufacturers must comply and be aware of sustainability related directives, regulations and standards. However, it is difficult for designers and manufacturers to find the relevant directives, regulations and standards for their particular product development processes. The brief review presented in this chapter aims to address this issue.

Regulations, directives and standards awareness is key for product developers and manufacturers because many of them are mandatory and others can help to improve

the environmental performance of products, and/or provide economic competitive advantage for companies in areas such as: resource efficiency or avoidance of fees (e.g. waste-related fees).

## References

- BSI (British Standard Institute). (2018). *What is a standard? & What does it do?* [online]. BSI. Retrieved March 2, 2018, from <https://www.bsigroup.com/en-GB/standards/Information-about-standards/what-is-a-standard/>.
- European Commission. (1985). *Environmental Impact Assessment (EIA) Directive 2014/52/EC*. [online]. EC. Retrieved March 2, 2018, from <http://ec.europa.eu/environment/eia/eia-legalcontext.htm>.
- European Commission. (1994). *Packaging and Packaging waste directive*. [online]. EC. Retrieved October 10, 2015, from <http://eur-lex.europa.eu/legal-content/EN/TXT/?uri=CELEX:31994L0062>.
- European Commission. (2008). *Directive 2008/98/EC on waste (Waste Framework Directive)*. [online]. EC. Retrieved March 2, 2018, from <http://ec.europa.eu/environment/waste/framework/>.
- European Commission. (2009a). *Energy Related Products (ErP) directive*. [online]. EC. Retrieved March 2, 2018, from <http://eur-lex.europa.eu/legal-content/EN/ALL/?uri=CELEX:32009L0125>.
- European Commission. (2009b). *Regulation (EC) No 244/2009: Ecodesign and energy labelling- Household lamps*. [online]. EC. Retrieved March 02, 2018, from [https://ec.europa.eu/growth/single-market/european-standards/harmonised-standards/ecodesign/lamps\\_household\\_en](https://ec.europa.eu/growth/single-market/european-standards/harmonised-standards/ecodesign/lamps_household_en).
- European Commission. (2009c). *EMAS Regulation (EC) No 1221/2009*. EC. Retrieved March 2, 2018, from [http://ec.europa.eu/environment/emas/emas\\_publications/policy\\_en.htm](http://ec.europa.eu/environment/emas/emas_publications/policy_en.htm).
- European Commission. (2010a). *Directive 2010/75/EU on industrial emissions (integrated pollution prevention and control)*. [online]. EC. Retrieved March 2, 2018, from <http://ec.europa.eu/environment/industry/stationary/ied/legislation.htm>.
- European Commission. (2010b). *Energy labelling directive (2010/30/EU)*. [online]. EC. Retrieved March 2, 2018, from <http://eur-lex.europa.eu/legal-content/EN/TXT/?uri=CELEX:32010L0030>.
- European Commission. (2010c). *Eco-Label Regulation (EC) No 66/2010*. [online]. EC. Retrieved March 2, 2018, from <http://eur-lex.europa.eu/legal-content/EN/TXT/?uri=CELEX:32010R0066>.
- European Commission. (2011). *Restriction of Hazardous Substances (RoHS)*. [online]. EC. Retrieved March 2, 2018, from [http://ec.europa.eu/environment/waste/rohs\\_eee/index\\_en.htm](http://ec.europa.eu/environment/waste/rohs_eee/index_en.htm).
- European Commission. (2012a). *Waste Electrical and Electronic Equipment recycling (WEEE)*. [online]. EC. Retrieved October 10, 2015, from [http://ec.europa.eu/environment/waste/weee/index\\_en.htm](http://ec.europa.eu/environment/waste/weee/index_en.htm).
- European Commission. (2012b). *Regulation (EC) EU 1194/2012: Ecodesign and energy labelling- Directional and LED lamps*. [online]. Retrieved March 2, 2018, from [https://ec.europa.eu/growth/single-market/european-standards/harmonised-standards/ecodesign/lamps\\_directional\\_led\\_en](https://ec.europa.eu/growth/single-market/european-standards/harmonised-standards/ecodesign/lamps_directional_led_en).
- IEC (International Electro Technical Commission). (2009). *IEC 62430: 2009. Environmentally conscious design for electrical and electronic products*. [online]. IEC. Retrieved March 2, 2018, from <https://webstore.iec.ch/publication/7005>.
- ISO (International Standardisation Organisation). (2000). *ISO 14020:2000-Environmental labels and declarations: General principles*. Retrieved March 3, 2018, from <https://www.iso.org/standard/34425.html?browse=tc>.
- ISO (International Standardisation Organisation). (2002). *ISO/TS 14048:2002-Environmental management: Life cycle assessment: Data documentation format*. Retrieved March 3, 2018, from <https://www.iso.org/standard/29872.html?browse=tc>.

- ISO (International Standardisation Organisation). (2006a). *ISO 14025:2006-Environmental labels and declarations: Type III environmental declarations: Principles and procedures*. Available Retrieved March 3, 2018, from <https://www.iso.org/standard/38131.html?browse=tc>.
- ISO (International Standardisation Organisation). (2006b). *ISO 14063:2006-Environmental management: Environmental communication: Guidelines and examples*. Retrieved March 3, 2018, from <https://www.iso.org/standard/34676.html?browse=tc>.
- ISO (International Standardisation Organisation). (2006d). *ISO 14044:2006-Environmental management: Life cycle assessment: Requirements and guidelines*. Retrieved March 3, 2018, from <https://www.iso.org/standard/38498.html?browse=tc>.
- ISO (International Standardisation Organisation). (2006e). *ISO 14064-1:2006-Greenhouse gases: Part 1: Specification with guidance at the organization level for quantification and reporting of greenhouse gas emissions and removals*. Retrieved March 3, 2018, from <https://www.iso.org/standard/38381.html?browse=tc>.
- ISO (International Standardisation Organisation). (2006f). *ISO 14064-2:2006 Greenhouse gases: Part 2: Specification with guidance at the project level for quantification, monitoring and reporting of greenhouse gas emission reductions or removal enhancements*. Retrieved March 3, 2018, from <https://www.iso.org/standard/38382.html?browse=tc>.
- ISO (International Standardisation Organisation). (2010). *ISO 14005:2010-Environmental management systems: Guidelines for the phased implementation of an environmental management system, including the use of environmental performance evaluation*. Retrieved March 3, 2018, from <https://www.iso.org/standard/43208.html?browse=tc>.
- ISO (International Standardisation Organisation). (2011). *ISO 14006:2011-Environmental management systems: Guidelines for incorporating eco-design*. Retrieved March 3, 2018, from <https://www.iso.org/standard/43241.html?browse=tc>.
- ISO (International Standardisation Organisation). (2012a). *ISO/TS 14033:2012-Environmental management: Quantitative environmental information: Guidelines and examples*. Retrieved March 3, 2018, from <https://www.iso.org/standard/43268.html?browse=tc>.
- ISO (International Standardisation Organisation). (2012b). *ISO 14045:2012-Environmental management: Eco-efficiency assessment of product systems: Principles, requirements and guidelines*. Retrieved March 3, 2018, from <https://www.iso.org/standard/43262.html?browse=tc>.
- ISO (International Standardisation Organisation). (2012c). *ISO/TR 14047:2012-Environmental management: Life cycle assessment: Illustrative examples on how to apply ISO 14044 to impact assessment situations*. Retrieved March 3, 2018, from <https://www.iso.org/standard/57109.html?browse=tc>.
- ISO (International Standardisation Organisation). (2012d). *ISO/TR 14049:2012-Environmental management: Life cycle assessment: Illustrative examples on how to apply ISO 14044 to goal and scope definition and inventory analysis*. Retrieved March 3, 2018, from <https://www.iso.org/standard/57110.html?browse=tc>.
- ISO (International Standardisation Organisation). (2013a). *ISO 14031:2013-Environmental management: Environmental performance evaluation: Guidelines*. Retrieved March 3, 2018, from <https://www.iso.org/standard/52297.html?browse=tc>.
- ISO (International Standardisation Organisation). (2013b). *ISO/TS 14067:2013-Greenhouse gases: Carbon footprint of products: Requirements and guidelines for quantification and communication*. Retrieved March 3, 2018, from <https://www.iso.org/standard/59521.html?browse=tc>.
- ISO (International Standardisation Organisation). (2013c). *ISO/TR 14069:2013-Greenhouse gases: Quantification and reporting of greenhouse gas emissions for organizations: Guidance for the application of ISO 14064-1*. Retrieved March 3, 2018, from <https://www.iso.org/standard/43280.html?browse=tc>.
- ISO (International Standardisation Organisation). (2014a). *ISO 14046:2014-Environmental management: Water footprint: Principles, requirements and guidelines*. Retrieved March 3, 2018, from <https://www.iso.org/standard/43263.html?browse=tc>.

- ISO (International Standardisation Organisation). (2014b). *ISO/TS 14072:2014-Environmental management: Life cycle assessment: Requirements and guidelines for organizational life cycle assessment*. Retrieved March 3, 2018, from <https://www.iso.org/standard/61103.html?browse=tc>.
- ISO (International Standardisation Organisation). (2015). *ISO 14001:2015-Environmental management systems: Requirements with guidance for use*. Retrieved March 3, 2018, from <https://www.iso.org/standard/60857.html?browse=tc>.
- ISO (International Standardisation Organisation). (2016a). *ISO 14004:2016-General guidelines on implementation*. Retrieved March 3, 2018, from <https://www.iso.org/standard/60856.html?browse=tc>.
- ISO (International Standardisation Organisation). (2016b). *ISO 14021:2016-Environmental labels and declarations: Self-declared environmental claims (Type II environmental labelling)*. Retrieved March 3, 2018, from <https://www.iso.org/standard/66652.html?browse=tc>.
- ISO (International Standardisation Organisation). (2016c). *ISO 14034:2016-Environmental management: Environmental technology verification (ETV)*. Retrieved March 3, 2018, from <https://www.iso.org/standard/43256.html?browse=tc>.
- ISO (International Standardisation Organisation). (2017a). *ISO 14026:2017-Environmental labels and declarations: Principles, requirements and guidelines for communication of footprint information*. Retrieved March 3, 2018, from <https://www.iso.org/standard/67401.html?browse=tc>.
- ISO (International Standardisation Organisation). (2017b). *ISO/TR 14073:2017-Environmental management: Water footprint: Illustrative examples on how to apply ISO 14046*. Retrieved March 3, 2018, from <https://www.iso.org/standard/72264.html?browse=tc>.
- ISO (International Standardisation Organisation). (2018). *ISO 14024:2018-Environmental labels and declarations: Type I environmental labelling: Principles and procedures*. Retrieved March 3, 2018, from <https://www.iso.org/standard/72458.html?browse=tc>.
- USDA (United States Department of Agriculture). (2018). *Difference between a regulation, directive and decision*. [online]. USDA. Retrieved March 2, 2018, from <http://www.usda-eu.org/eu-basics-questions/difference-between-a-regulation-directive-and-decision/>.

# Chapter 3

## Review of Life Cycle Impact Assessment (LCIA) Methods and Inventory Databases



You Wu and Daizhong Su

**Abstract** In this chapter, a wide range of Life Cycle Assessment (LCA) methods, new initiative for reducing emissions and improving resource efficiency, and Product Environmental Footprint are examined, in order to introduce the research tendency in this field and clarify the differences among these Life Cycle Impact Assessment (LCIA) methods. The LCIA methods are broadly categorized as *resource based* and *emission based*. Life Cycle Inventory (LCI) database are also investigated, and the features of the generic LCI database are presented. The data formats of the ecoinvent database are deeply examined, with the aim of clarifying the attributes, types of each data components to help users to understand the role of inventory database in the practices.

**Keywords** Life cycle assessment · Life cycle impact assessment method · Environmental product declarations · Product environmental footprint · Life cycle inventory · Life cycle inventory database · EcoSpold

### 3.1 Introduction

Life cycle assessment (LCA) is a multi-criteria and systematic procedure for compiling material and energy flows of a product or service and evaluating the environmental impacts potentially generated throughout its life cycle (ISO 2006a). The basic rationale behind the LCA is about tracking the major stages and processes of the product lifecycle, from raw material extraction, manufacturing, product use, and recycling through to final disposal, in order to identify and quantify the environmental impacts that occur at each stage. LCA has been recognised as a key tool for identifying the potential environmental impacts of products and services.

---

Y. Wu (✉) · D. Su

Advanced Design and Manufacturing Engineering Centre, School of Architecture, Design and the Built Environment, Nottingham Trent University, Nottingham, UK  
e-mail: [you.wu@ntu.ac.uk](mailto:you.wu@ntu.ac.uk)

D. Su

e-mail: [daizhong.su@ntu.ac.uk](mailto:daizhong.su@ntu.ac.uk)

According to ISO 14040 (ISO 2006a) and ISO 14044 (ISO 2006b) standards, LCA is carried out in four steps: goal and scope definition, life cycle inventory (LCI) analysis, life cycle impact assessment (LCIA), and finally the results interpretation. The first step is to define the analysis scope of environmental impact. The LCI involves collecting and building the inventory data for the analysis of products or services. In LCIA, the boundaries and data are applied to the product or service system under investigation, which usually involves a series of mathematical calculations. The interpretation is the final step during which a summary of the calculation results is given in accordance with the goal and scope definitions. In this step, the weighting and grouping can provide a further degree of inconsistency among LCIA results (Ahroth et al. 2010). The grouping method refers to classify the environmental impact categories based on the study objectives, or their relative importance. The weighting refers to scale the environmental impacts according to a group of indexes representing their relative importance, and these indexes are determined by the selected LCA methodology.

## 3.2 LCIA Methods

The LCIA methods are required to apply in the LCIA phrase, by which the aggregation of the inventory data showing emissions and resources consumptions are converted into impact categories. The impact categories are also known as indicators, and these indicators link different types of LCI results and cover different impact categories and characterization models. Common impact categories are climate change, human and ecotoxicity, acidification, eutrophication and resource depletion. The indicators of the specific impact categories can be classified to midpoint or endpoint. A midpoint impact for the impact category climate change is for example kg CO<sub>2</sub>-equivalents/kg gas, a referring endpoint impact could be impact on nature (such as a rise in sea level or global average temperature). While endpoint indicators allow users to clarify concrete environmental impacts, their calculation is associated with higher uncertainties than midpoint indicators. The main LCIA methods are reviewed, and their features and midpoint/endpoint impact categories are presented in Table 3.1.

In addition to ISO 14040/44 there are other specific assessment frameworks for environmental assessment on product level such as ISO 14067: Carbon Footprint of Product (Garcia and Freire 2014), French Environmental Footprint (BPX 30-323) (PRé 2012) and UK's Product Carbon footprint guidelines PAS 2050 (BSI 2011). They all employ the Life Cycle approach as a basis from ISO 14044 standard.

The carbon footprint defined in ISO 14067 of product international standard specifies principles and requirements for studies to quantify the carbon footprint of a product, based on the LCA specified in ISO 14040/44. However, it only allows users to assess the impact category of climate change. The French Environmental Footprint (BPX 30-323) establishes the prospect of regulatory communication of environmental information relating to the product. It is based on the standards ISO 14040/44

**Table 3.1** Brief descriptions and environmental impact categories of major LCIA methods

Methods	Descriptions	Midpoint impact categories	Endpoint impact categories
Ecological Footprint	It considers biologically productive land and sea area to produce all consumed products and absorb generated waste (Hischer et al. 2010)	LAND occupation Climate change Nuclear energy use	Global hectare (Consumption of hectare with global average bioproductivity, gha)
Cumulated Energy Demand	It assesses primary energy required for production, use and disposal of a product (Hischer et al. 2010)	Fossil Nuclear Primary forest Biomass	Non-renewable resources Renewable resources
CML	It assesses specific impact categories and this method is divided into two versions: baseline and non-baseline. It only assesses midpoints' impacts (Guinée 2002)	Depletion abiotic resources Climate change Stratospheric ozone depletion Human toxicity Marine ecotoxicity	N/A
Eco-indicator 99	It replaces Eco-indicator 95, and covers all emission categories and parts of the resource categories (PRé 2015)	Climate change Ozone layer depletion Acidification/eutrophication Carcinogenic Fossil resources	Human health Ecosystem quality Resource depletion
IMPACT 2002+	It is mainly based on Eco-indicator 99 and CML 2002 linking 14 midpoint categories to four damage categories (Weisbrod and Van Hoof 2011)	Human toxicity Respiratory effects Ionizing radiation Ozone depletion Photochemical oxidant Aquatic ecotoxicity Terrestrial ecotoxicity	Human health Ecosystem quality Climate change Natural resources

(continued)



Table 3.1 (continued)

Methods	Descriptions	Midpoint impact categories	Endpoint impact categories
USEtox 2.01	It is a scientific consensus model for assessing human and ecotoxicological impacts of chemical emissions in life cycle assessment (Fankle et al. 2015)	Freshwater ecotoxicity	Carcinogenic Non-carcinogenic
EDIP 2003	It is a follow-up of the EDIP 97 methodology, and it covers only emission categories and considers midpoint impacts (Ciroth 2014)	Global warming Ozone depletion Acidification Terrestrial eutrophication Aquatic eutrophication (N-eq, P-eq) Ozone formation (human, vegetation)	Human toxicity (exposure route via air, water, soil) Ecotoxicity (water acute, water chronic, soil chronic) Waste (hazardous, slags/ashes, bulk waste, radioactive waste)
IMPACT World+	It is developed as a joint major update to IMPACT 2002+, EDIP, and LUCAS methodology, and it assesses local and regional impact categories (Bulle et al. 2014)	Human toxicity Photochemical ozone formation Ozone layer depletion Global warming	Ecotoxicity Acidification Eutrophication Water Land use Resource use
ReCiPe	It is a follow up of Eco-indicator 99 and CML 2002 methods that integrates and harmonizes midpoints and endpoint approaches (Goedkoop et al. 2009)	Climate change Ozone depletion Terrestrial acidification Freshwater eutrophication Marine eutrophication Human toxicity Photochemical oxidant formation Particulate matter formation Terrestrial ecotoxicity	Freshwater ecotoxicity Marine ecotoxicity Ionising radiation Agricultural land occupation Urban land occupation Natural land transformation Depletion of fossil fuel resources Depletion of mineral Depletion of freshwater resources

(continued)

Table 3.1 (continued)

Methods	Descriptions	Midpoint impact categories	Endpoint impact categories
ILCD 2011 Midpoint	It analyses the emissions into air, water and soil, as well as the resources consumed in terms of their contributions to different impacts on human health, natural environment, and natural resources (European Commission 2011b)	Climate change Ozone depletion Human toxicity Particulate matter/respiratory inorganics Photochemical ozone formation	Ionizing radiation impacts Acidification Eutrophication Ecotoxicity Land use and resource depletion
TRACI 2.1	It is a tool for the reduction and assessment of chemical and other environmental impacts (Bare 2011). It is a midpoint oriented LCA method (Hischier et al. 2010)	Acidification Ecotoxicity Eutrophication Ozone depletion Smog depletion Climate change	Resource depletion (fossil fuels) Human health (air pollutants criteria, carcinogenic, non-carcinogenic)
LC-Impact	It is an environmental assessment method focused on a global level, and spatially differentiated characterization factors are developed to support the assessment on a regionalized scope (Ponsioen et al. 2014)	Water stress Climate change Toxicity Photochemical ozone formation Particulate matter formation Lionising radiation	Ozone depletion Eutrophication Land stress Acidification Fossil resource scarcity Mineral resource scarcity
Ecological Scarcity 2013	It weights environmental impacts with eco-factors, which are derived from political targets or environmental laws (Frischknecht and Knöpfel 2014)	Water sources Energy sources Mineral sources Land use Global warming Ozone layer depletion Main air pollutants and PM Carcinogenic substances into air Heavy metals into air Water pollutants POP into water	Heavy metals into water Pesticides into soil Heavy metals into soil Radioactive substances into air Radioactive substances into water Noise Non-radioactive Waste to deposit Radioactive waste to deposit Deposit waste

and follows international European normative developments (PRé 2012). BPX 30-323 gives general principles for the environmental communication of products. The environmental communication includes indicators limited in number and specific to a category of product. UK's Product Carbon footprint (PAS 2050) specifies the assessment of the life cycle greenhouse gas emissions of goods and services. The PAS 2050:2011 specifies requirements for the assessment of the life-cycle GHG emissions associated with the life cycle of goods and services ("products"), also based on life cycle assessment techniques and principles provided in ISO14040/44 (European Commission 2011a).

Based on the deep comparison, these LCIA methods can be categorised into two groups: *resource based methods* and *emission based methods*. The resource based methods focus on resources (inputs) taken from the nature with resource indicators (e.g. Cumulated Energy Demand); emission based methods focus on outputs to the nature, assessing one or multiple emissions (outputs) with the help of extended assessment models (e.g. CML 2002, ReCiPe).

Based on this, an overview of resource-oriented approaches identified based on different sources is described as follows:

#### Resource-oriented approaches for environmental indicators

- Cumulated energy use: All primary energy required for production, use and disposal of a product.
- Ecological footprint: Considers all biologically productive land and sea area necessary to produce all consumed products and absorb generated waste. Covers directly or indirectly all resources categories.

#### Emission-oriented approaches for environmental indicators

- CML: CML uses nine baseline impact categories and twelve study-scientific impact categories, which can be excluded if appropriated. It considers only midpoint impacts.
- Eco-indicator 99: Follow-up of Eco-indicator 95, covering all emissions and parts of the resource categories. Considers only endpoint impacts.
- EDIP 2003: Model is a follow-up of the EDIP 97 methodology and covers only emission categories and considers midpoint impacts.
- IMPACT 2002+: It is mainly based on Eco-indicator 99 and CML 2002 linking 14 midpoint categories to four damage categories.
- ReCiPe: It is a follow up of Eco-indicator 99 and CML 2002 methods, which integrates and harmonizes midpoint and endpoint approaches.
- Ecological scarcity method: Weights environmental impacts with eco-factors, which are derived from political targets or environmental laws (critical flows).
- IMPACT World+: It implements impact modelling approaches developed as a major joint update to existing LCIA methods, including IMPACT 2002+ (Europe), EDIP (Scandinavia) and LUCAS (Canada).
- ILCD 2011 Midpoint: It analyses several life cycle impact assessment methodologies to reach consensus on the recommended method for each environmental theme, at both midpoint and endpoint.

- TRACI 2.1: Approaches were developed specifically for the United States using input parameters consistent with U.S. locations.
- LC-Impact: It aims to evaluate the equality systems, human health, and resources at the global level.

Approach covering one impact

- USEtox: Scientific consensus model for comparative assessment of toxics of goods and services.

### 3.3 Product Environmental Footprint (PEF)

To further classify the indicators environmental categories have been derived from current standardization activities of the European Commission. In its Roadmap to a Resource Efficient Europe, the European Commission developed a dashboard of indicators to illustrate complex resource use impacts. This dashboard contains the categories material use, land, water and carbon (European Commission 2012). Also, within the Product Environmental Footprint (PEF) a more comprehensive range of categories is provided (Manfredi et al. 2012). These categories of the PEF and the EU dashboard are illustrated in Table 3.2.

The Directorate-General for the Environment of the European Commission and the Joint Research Centre (JRC IES) have worked together to develop the methodology of the 'Environmental Footprint'. The methodology refers to a way to measure the environmental performance of products (PEF) (Manfredi et al. 2012) and of organisations (OEF) (Pelletier et al. 2012) by adopting a life cycle approach and basing on the material, energy, emission and waste flows occurring throughout the supply chains. The two slightly different variations were developed within an EC-Project delivering its first results in March 2011 and the final methodological guide in April 2013. Various standards and guiding documents served as references for an attempt to develop a harmonised European methodology, which include International Reference Life Cycle Data System (ILCD) Handbook, ISO 14040/44, WRI/WBCSD GHG protocol, ISO 14025, PAS 2050, BP X30, Sustainability Consortium, Global Reporting Initiative, WRI GHG Protocol, CDP Water Footprint, ISO 140064, DEFRA guidance on GHG reporting, etc. A pilot phase for both PEF and OEF and a final technical guide is expected within the next years (2016 end of pilot phase) (European Commission 2016).

**Table 3.2** Environmental impact categories for EU dashboard and PEF

EU dashboard	Product environmental footprint
Abiotic resources	Abiotic resources, Aquatic eutrophication, Acidification, Land use,
Biotic resources	Respiratory inorganics, Human health, Water, Terrestrial eutrophication,
Land use	Ozone depletion, Climate change, Ionizing radiation, Ecotoxicity, Ozone
Water	formation

The Environmental Footprint aims to specify the ISO 14040/44. In the final draft of the Environmental Footprint Guide (Product Environmental Footprint (PEF) Guide) the procedure to solve allocations is similar to that of ISO 14040/44. However, as outcome of the ongoing pilot phase standardised allocation factors for specific product category are expected.

26 pilots have been conducted to assess PEF/OEF from November 2013 to December 2016, out of 26 pilots, 16 submitted their PEFCR/OEFSR to the EC by 21 December 2016 (62%), and an additional 4 pilots submitted their PEFCR/OEFSR to the EC by 31 January 2017 (77%). Two pilots were discontinued in 2016, the remaining four pilots have been delayed (Kerkhof et al. 2017). 77% of all pilots submitted their final draft PEFCR/OEFSR to the EC by 31 January 2017. Since the relevant pilot phases are still ongoing, a final analysis of the completeness of the PEF was not possible at the time of writing this chapter.

### 3.4 Environmental Product Declarations

The results of implementing these LCIA methods are not only applicable for identifying the environmental impacts or root of pollutions caused by products or services, but also enable to declare product/service's environmental performance in the form of eco-labelling. ISO 14025 is established to comply with ISO standards in the development of Environmental Product Declarations (EPD), eco-labels for utilization of business-to-business communication (Pastor et al. 2014; Finkbeiner 2011). Environmental declarations are becoming increasingly important as a means of communicating environmental impact data about products in the supply chain (Finkbeiner 2013). The EPD usually summarise details of the environmental impacts of the product under scrutiny, for example, the global warming potential, for each aspect of the product's life cycle. More specifically, environmental declarations are a standardised type of LCA study, which enable comparisons between products that provide the same function (BSI 2011).

There are a variety of environmental declaration schemes across industrial sectors, such as Eco-Leaf, eco-profile, environmental profiles and product environment profiles (PEP) (BSI 2011). Eco-labelling and declarations are widely used to certify products or services' environmental performance in order to influence consumers' green consumption behaviour and companies' sustainable production. For the present, there are a number of schemes and initiatives on the market that offer an assessment of products' carbon footprint. The regulatory rule in the European Union market is Regulation (EC) No 66/2010 (Eco-label Regulation), and it has been adopted by the major large businesses. Most carbon footprint certification tools, whether by a third party or a company working on their own products, rely on a range of LCA approaches and data, for instance: The Carbon Reduction Institute offers carbon neutral certification schemes (Whittaker et al. 2013); the non-profit association, Climatop, provides labelling for climate-friendly products (Andersen 2013).

The advantages of applying environmental product declarations include: first it avoids the necessity to perform new LCA studies for the specific products of focus (performing LCAs are time-consuming, data intensive). Also, as environmental declarations follow a set of strict and mature rules and standards, their results make them suitable for comparison across products. The way in which businesses monitor their environmental impact throughout business activities is also important and the certification of environmental management systems has been shown to have a significantly positive effect on the innovation of more environmentally friendly products.

### 3.5 Selection of LCIA Methods

The indicators of these LCA methods have to allow high aggregation and comparisons between products, be comprehensible and easy to communicate. Since there are also other requirements, a prioritisation of their relevance and a structuration of different possible requirements are needed. To address these requirements a selection based on the scientific approach of a RACER analysis, is normally used to screen the prior identified LCA method indicators. The RACER analysis is based on an approach to evaluate the value of scientific tools for application in policy making. The European Commission recommends the RACER criteria in its publication “Impact Assessment Guidelines” as criteria indicators should fulfil. RACER is an acronym for Relevant, Accepted, Credible, Easy and Robust (European Commission 2006). An indicator has to be relevant, which means it has to be closely linked to specified targets. The category “accepted” demands an indicator to be easily understood and accepted by relevant stakeholder groups. To occur credible, an indicator should be unambiguous and easy to interpret, even for non-experts, and contain a transparent and reproducible calculation methodology. Furthermore, the indicator has to be easy to monitor. Therefore, necessary data has to be easily available and technical requirements (about software and expertise) have to be appropriate to provide technical feasibility. As another attribute the indicator is expected to be robust, i.e. regarding uncertainties and assumptions within the characterisation model.

For better comparability it is important that all categories are expressed by one aggregated LCA indicator. Furthermore, the indicator should experience high acceptance by policy makers as well as in industry context. Therefore, it has to be comprehensible and easy to communicate. Limited effort to calculate the indicator increases probability of use by industrial decision makers, while allowing measuring resource efficiency targets of the EU (e.g. EU 2020 strategy) is important for its political relevance. Both comprehensible and reproducible indicator scores as well as less complex and intuitive understandable calculation methods increase the credibility for non-experts and end users. The monitoring of the indicator is easier, if there is little effort for data collection necessary (important data is already available or easy to collect). The relevance of the indicator for scientific use as well as the consistency of the methodology are important characteristics for the robustness of the indicator. The use of multiple methods to collect data as well as several needs to revise the indicator

may create some doubts about its consistency. Furthermore, high standardisation and transparency are important attributes.

It is necessary to notice that IMPACT World+ and LC-Impact are relatively new methodologies. At the time of writing this chapter, the normalisation factors of IMPACT World+ and midpoint characterization factors of LC-Impact have still not been completed according to the information of their official websites (IMPACT World 2016; LC-IMPACT 2016). Moreover, four core points related to the LCA methodology are concluded according to the review findings, with the aim of clarifying the pathways to select the suitable method:

- the official statement expressing the essential characteristics and function of a method.
- the supportive data properties and their availability.
- the unit of the environmental impact measurement.
- the inner structure of environmental impact indicator compositions as this determines the difficulty level of analytic results interpretation.

### 3.6 LCI Database Tools

Within the inventory analysis level, for every process of the flow crossing the product system needs to be specified in order to create the starting point of the assessment. In many cases, this process requires using third-party databases to create a complete LCI to describe the performance of product processes and stages. This section offers an overview of major LCI databases and their formats, in order to clarify general rules applicable to the database selection.

LCI databases have various characteristics, for instance, ecoinvent is a professional and widely used LCI database (Weidema et al. 2013), World-Food LCA Database is a sector based database, and the European Reference Life Cycle Database (ELCD) provides data collecting from front-running EU-level business associations. The investigated LCI database and their features are presented in Table 3.3.

The data format of the ecoinvent is named EcoSpold, and the main LCA software (e.g. SimaPro, openLCA) accepts this format. Apart from EcoSpold, the International Reference Life Cycle Data System (ILCD) format was introduced by the European Commission in 2005, along with the European Reference Life Cycle Database (ELCD). Some national or sector-based organisations also archive life cycle inventory data, e.g. the World Food LCA database (WFLDB) and Material Flow Accounts, and the data format of these databases are usually spreadsheet based, which are not supported by LCA software to import, therefore LCA practitioners are required to convert the data format into the EcoSpold or ILCD format, or manually input values through the software interfaces after data quality examination.

**Table 3.3** LCI database and their features

Databases	Features
Ecoinvent	It comprises LCI data from the energy, transport, building materials, chemicals, paper and pulp, waste treatment and agricultural sectors, based on the Swiss and European demand patterns (PRé 2015)
GaBi	It includes all relevant information in view of the data quality and scope of the application of the respective LCI result/data set, and the data is presented with the referenced functional unit (Chiu and Chu 2012)
World Food LCA Database (WFLDB)	WFLDB represents agricultural primary products and processed food products, and it assists companies and environmental authorities in processes of eco-design of food products and Environmental Product Declarations (EPD) (Whittaker et al. 2013)
European Reference Life Cycle Database (ELCD)	ELCD comprises LCI data from EU business associations and other sources for key materials, energy carriers, transport, and waste management (Garraín et al. 2015)
EXIOBASE	It is a spreadsheet based database that can be used for the analysis of the environmental impacts associated with the final consumption of product groups (Wood et al. 2015)
Global Emission Model for Integrated Systems (GEMIS)	GEMIS covers processes for energy, materials, and transport, as well as recycling and waste treatment processes. Material processes are based on EU data, transport processes are based on EU and US data (Skarvelis-Kazakos et al. 2009)
U.S. Life Cycle Inventory Database	It serves as a central repository for information about the total energy and resource impacts of developing and using various commercial building materials, components, and assemblies (PRé 2015)
Chinese Core Life Cycle Database (CLCD)	CLCD provides data of more than 600 unit processes ranging from energy, metal/non-metal, chemicals, to transportation and waste treatment. The main data resources are government or industrial statistics and calculated based on ingredients and batch formula (Li et al. 2013)

(continued)



**Table 3.3** (continued)

Databases	Features
Material Flow Accounts	It is a database contributed by Eurostat's material flow accounts results, and it presents flow accounts framework by estimating the material footprints of the goods consumed in the EU (Wiedmann et al. 2015)
DataSmart	It is a database of the North American region, and it is developed through expanding USLCI data, ecoinvent v2.2 data, in addition, over 700 processes covering textiles, packaging, biomaterials, dairy industries, U.S. state electricity mixes are included (EarthShift 2015)

### 3.7 Ecoinvent Database Formats: EcoSpold1 and EcoSpold2

EcoSpold1 was introduced in 2000, and its latest version, EcoSpold2, was launched with ecoinvent version 3 in 2013. EcoSpold1 and EcoSpold2 are essentially an XML (extended markup language) format file, and they have evolved from the international SPOLD data exchange format (Frischknecht and Rebitzer 2005) and international technical specification ISO/TS 14048. Each EcoSpold format file presents information and values of processes and substances. Compared with the EcoSpold1, EcoSpold2 includes many new sections, such as 'mathematical relation' and 'variable names'. The literature investigation shows that the default EcoSpold2 format file is systematically and hierarchically built with 233 data types, but not all of the data types are needed to implement a LCA. The required data types are filtered from the default EcoSpold2 schema documentation, and their top-level structure is depicted in Fig. 3.1. Through examining the requirements of each data section, it is clear that the central data section is 'Activity Description' (see Fig. 3.1), which records functional units, values, country codes of processes, and flow properties.

The structure of a standard EcoSpold1 format is depicted in Fig. 3.2, and the role of each component is also presented in Fig. 3.2. The key component in EcoSpold1 format is the 'process information' that records the functional units, values, category and subcategory of flow data, which is the main figure used to illustrate the implementation of a LCA calculation.

The ecoinvent centre offers a free tool, EcoEditor, which is developed to create, edit, review and upload EcoSpold1 and EcoSpold2 format files (E et al. 2013). Additionally, this tool supports the format conversion between EcoSpold1 and EcoSpold2 format files.

LCI databases (including ecoinvent) may contain missing data or uncertainties. Most missing data can be filled through examining statistics from relevant reports, utilising commercial database, or conducting independent studies (Suh et al. 2013).

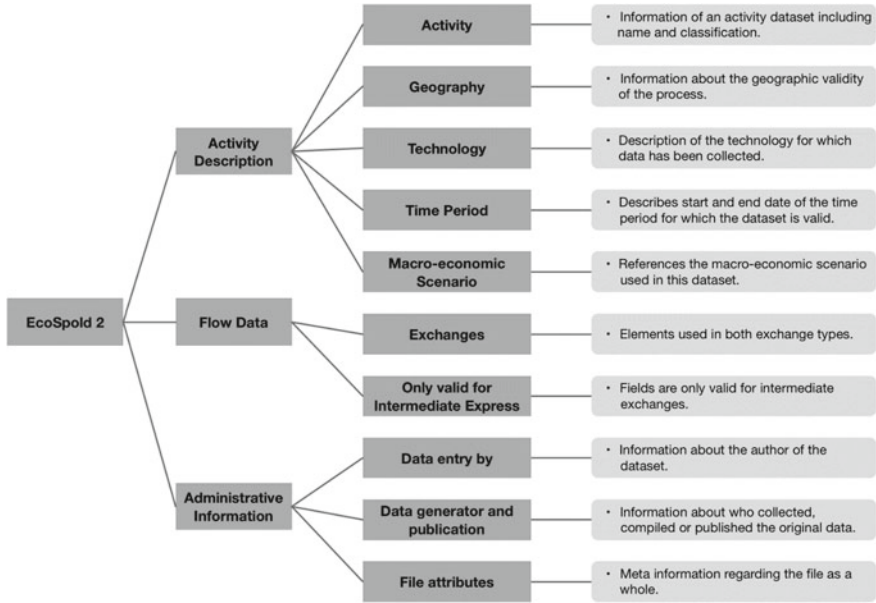

**Fig. 3.1** The compulsory data sections of EcoSpold2 format file and their high-level structure (The contents refer for EcoSpold2 Documentation (ecoinvent n.d.))

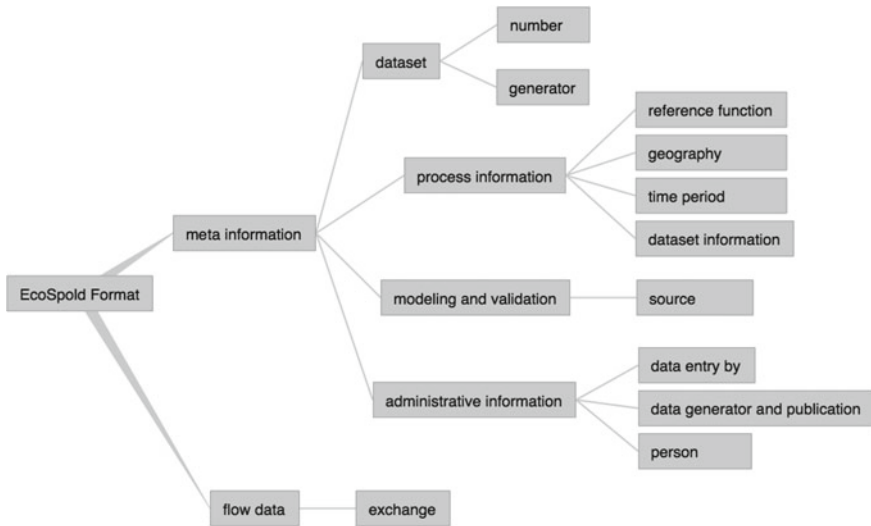

**Fig. 3.2** The structure of EcoSpold1 format file (the structure refers Frischknecht and Rebitzer 2005)

In the case of using data from multiple data sources, a framework examining data quality is introduced by ISO 14040/44 standards, and the quality indicators include: time-related coverage, geographical coverage, technology coverage, precision, completeness, representativeness, consistency, reproducibility, sources of the data, and uncertainty (ISO 2006a, b). This framework sets the minimum requirements for LCA practitioners to assess the fitness and quality of the selected data. Also, the review findings show that there is not a common data format accepted by the LCI databases and LCA software, so LCI data format conversion is still a barrier to improving the efficiency of LCA practices. Chapter 8 will introduce methods to convert EcoSpold format files into SQL format, which is the most standard database format for software engineering.

### 3.8 Conclusions

LCIA methods have been developed for more than two decades, a wide range of LCIA methods are reviewed in this chapter, and their performance indicators in the midpoint and endpoint levels are highlighted, including the emerging initiative that is promoted in the EU, PEF, the status of which is also reported. Except these reported LCIA methods, there are a few new methods are under development, LC-IMPACT (2016), at the time of writing this chapter, there is no solid evidence to prove that they are ready to use in the professional LCA software, therefore it is not reported here.

In the LCA practises, the analysis/study objectives and demands or the analysed product/sector's features require the necessity of selecting feasible LCIA methods, therefore, the findings of this review highlights their characteristics and applicable requirements for users to select appropriate LCIA methods. Additionally, this review not only covers the major LCIA methods, but also selects the latest version of corresponding LCIA methods to examine, because these LCIA methods are regularly updated which usually involves the factors for a specific impact category, or the weighting options for the damage impacts. The review of the latest version will be helpful for users to understand the trending of LCIA methods and to obtain accurate LCA results by implementing these methods.

Moreover, the main LCI databases and their applicable scope are also reviewed in this chapter, particularly, the Ecoinvent database, and its data format and components' attributes are deeply introduced. The review findings are helpful for LCA practisers to select feasible LCI databases to fulfil missing LCI data, as LCA requires to build inventory data for analysed target to model its life cycle. LCI databases may contain missing data or uncertainties. Most missing data can be obtained from relevant business/association/government reports, utilising commercial databases, or conducting independent studies (Suh et al. 2013). In order to fill these secondary data into the selected LCI database (e.g. Ecoinvent database), the understanding of the role and data components' attributes is necessary. In the case of using data from multiple data sources, a framework examining data quality is introduced by ISO 14040/44

standards, and the quality indicators include: time-related coverage, geographical coverage, technology coverage, precision, completeness, representativeness, consistency, reproducibility, sources of the data, and uncertainty (ISO 2006a, b). This framework sets the minimum requirements for LCA practitioners to assess the fitness and quality of the selected data.

**Acknowledgements** The authors acknowledge the support received from the CIRC4Life project (Grant agreement number: 776503) supported by the European Commission's Circular Economy programme.

## References

- Ahlroth, P., Alatalo, R. V., & Suhonen, J. (2010). Reduced dispersal propensity in the wingless waterstrider *Aquarius najas* in a highly fragmented landscape. *Oecologia*, 162(2), 323–330.
- Andersen, O. (2013). Consequential life cycle environmental impact assessment. *Unintended consequences of renewable energy* (pp. 35–45). London: Green Energy and Technology and Springer.
- Bare, J. (2011). TRACI 2.0: The tool for the reduction and assessment of chemical and other environmental impacts 2.0. *Clean Technologies and Environmental Policy*, 13(5), 687–696.
- BSI, British Standard Institution. (2011). *Specification for the assessment of the life cycle greenhouse gas emissions of goods and services*. London.
- Bulle, C., et al. (2014). Comparing IMPACT World+ with other LCIA methodologies at end-point level using the Stepwise weighting factors. Retrieved 21 April, 2016, from <http://lca-net.com/files/Poster-SETAC-Basel-Bulle-et-al-V2.pdf>.
- Chiu, M.-C., & Chu, C.-H. (2012). Review of sustainable product design from life cycle perspectives. *International Journal of Precision Engineering and Manufacturing*, 13(7), 1259–1272.
- Ciroth, A. (2014). *openLCA 1.4 overview and first steps* (pp. 1–31). Retrieved 15 December, 2015, from [http://www.openlca.org/documents/14826/0/openLCA\\_1+4\\_overview\\_and\\_first\\_steps\\_v1.pdf](http://www.openlca.org/documents/14826/0/openLCA_1+4_overview_and_first_steps_v1.pdf).
- E, M. R., et al. (2013). ecoEditor–ecoinvent. Retrieved 12 February, 2017, from <http://www.ecoinvent.org/data-provider/data-provider-toolkit/ecoeditor/ecoeditor.html>.
- EarthShift. (2015). DataSmart life cycle inventory. Retrieved 27 April, 2016, from <http://earthshiftsustainability.com/services/software/datasmart-life-cycle-inventory/>.
- ecoinvent. (n.d.). ecoEditor for ecoinvent version 3 ecoinvent, ed. *ecoinvent*. Retrieved 12 March, 2017, from <http://www.ecoinvent.org/data-provider/data-provider-toolkit/ecospold2/ecospold2.html>.
- European Commission. (2011a). *Analysis of existing environmental footprint methodologies for products and organizations: Recommendations, rationale, and alignment* (pp. 1–61). Retrieved 20 April, 2016a, from <http://ec.europa.eu/environment/eussd/pdf/Deliverable.pdf>.
- European Commission. (2011b). *International reference life cycle data system (ILCD) handbook-framework and requirements for life cycle impact assessment models and indicators* (pp. 1–116). Retrieved 19 December, 2015b, from <http://eplca.jrc.ec.europa.eu/uploads/ILCD-Handbook-LCIA-Framework-Requirements-ONLINE-March-2010-ISBN-fin-v1.0-EN.pdf>.
- European Commission. (2012). Options for resource efficiency indicators. Retrieved 26 December, 2016, from [http://ec.europa.eu/environment/consultations/pdf/consultation\\_resource.pdf](http://ec.europa.eu/environment/consultations/pdf/consultation_resource.pdf).
- European Commission. (2006a). *Impact assessment guidelines* (pp. 1–49). Retrieved 15 December, 2015, from [http://www.funzionepubblica.gov.it/media/263857/2005\\_impact\\_assessment.pdf.pdf](http://www.funzionepubblica.gov.it/media/263857/2005_impact_assessment.pdf.pdf).

- European Commission. (2016b). Single market for green products—the product environmental footprint pilots—environment—European commission. Retrieved 26 December, 2016, from [http://ec.europa.eu/environment/eussd/smgp/ef\\_pilots.htm](http://ec.europa.eu/environment/eussd/smgp/ef_pilots.htm).
- Fantke, P., et al. (2015). *USEtox 2.0 user manual* (Version2) (pp. 1–30). Retrieved 21 April, 2016, from <http://usetox.org>.
- Finkbeiner, M. ed., (2011). *Towards life cycle sustainability management*. Springer Science & Business Media.
- Finkbeiner, M. (2013). From the 40s to the 70s—the future of LCA in the ISO 14000 family. *The International Journal of Life Cycle Assessment*, 18(1), 1–4.
- Frischknecht, R., & Knöpfel, S. B. (2014). Ecological scarcity 2013—new features and its application in industry and administration—54th LCA forum, Ittigen/Berne, Switzerland, December 5, 2013. *The International Journal of Life Cycle Assessment*, 19(6), 1361–1366.
- Frischknecht, R., & Rebitzer, G. (2005). The ecoinvent database system: A comprehensive web-based LCA database. *Journal of Cleaner Production*, 13(13–14), 1337–1343.
- Garcia, R., & Freire, F. (2014). Carbon footprint of particleboard: A comparison between ISO/TS 14067, GHG Protocol, PAS 2050 and Climate Declaration. *Journal of Cleaner Production*, 66(C), 199–209.
- Garraín, D., et al. (2015). Background qualitative analysis of the European Reference Life Cycle Database (ELCD) energy datasets—part I: Fuel datasets. *SpringerPlus*, 4(1), 151.
- Goedkoop, M., et al. (2009). *ReCiPe 2008*. A life cycle impact assessment method which comprises harmonised category indicators at the midpoint and the endpoint level; First edition Report I: Characterisation; 6 January 2009. <http://www.lcia-recipe.net>.
- Guinée, J. B. (2002). Handbook on life cycle assessment operational guide to the ISO standards. *The International Journal of Life Cycle Assessment*, 7(5), 311–313.
- Hischier, R., et al. (2010). Implementation of life cycle impact assessment methods data, v2.2 (2010), ecoinvent report No. 3. Retrieved 20 April, 2016, from [https://www.ecoinvent.org/files/201007\\_hischier\\_weidema\\_implementation\\_of\\_lcia\\_methods.pdf](https://www.ecoinvent.org/files/201007_hischier_weidema_implementation_of_lcia_methods.pdf).
- IMPACT World. (2016). IMPACT World. Retrieved 29 June, 2016, from <http://www.impactworldplus.org/en/index.php>.
- ISO. (2006a). *14040: Environmental management—life cycle assessment—principles and framework*. London: British Standards Institution.
- ISO. (2006b). *ISO 14044: Environmental management—life cycle assessment—requirements and guidelines*. International Organization for Standardization.
- Kerkhof, A., et al. (2017) Evaluation report: Technical evaluation of the EU EF pilot phase. Available at: [http://ec.europa.eu/environment/eussd/smgp/pdf/HD\\_pilot\\_eval\\_final.pdf](http://ec.europa.eu/environment/eussd/smgp/pdf/HD_pilot_eval_final.pdf).
- LC-IMPACT. (2016). LC-IMPACT. Retrieved 24 July, 2016, from <http://www.lc-impact.eu/>.
- Li, T., et al. (2013). Environmental emissions and energy consumptions assessment of a diesel engine from the life cycle perspective. *Journal of Cleaner Production*, 53(C), 7–12.
- Manfredi, S., et al. (2012). Product Environmental Footprint (PEF) Guide. Retrieved 26 December, 2016, from <http://ec.europa.eu/environment/eussd/pdf/footprint/PEF%20methodology%20final%20draft.pdf>.
- Pastor, M. C., Mathieux, F., & Brissaud, D. (2014). Influence of environmental European product policies on product design—current status and future developments. *Procedia CIRP*, 21, 415–420.
- Pelletier, N., et al. (2012). Organisation Environmental Footprint (OEF) Guide. Retrieved 26 December, 2016, from [http://ec.europa.eu/environment/eussd/pdf/footprint/OEF%20Guide\\_final\\_July%202012\\_clean%20version.pdf](http://ec.europa.eu/environment/eussd/pdf/footprint/OEF%20Guide_final_July%202012_clean%20version.pdf).
- Ponsioen, T. C., Vieira, M. D. M., & Goedkoop, M. J. (2014). Surplus cost as a life cycle impact indicator for fossil resource scarcity. *The International Journal of Life Cycle Assessment*, 19(4), 872–881.
- PRé. (2012). *Life cycle-based sustainability—standards & guidelines* (pp. 1–6). Retrieved 20 April, 2016, from <https://www.pre-sustainability.com/download/Life-Cycle-Based-Sustainability-Standards-Guidelines.pdf>.

- PRé. (2015). *SimaPro database manual methods library* (pp. 1–82). Retrieved 19 December, 2015, from <https://www.pre-sustainability.com/download/DatabaseManualMethods.pdf>.
- Skarvelis-Kazakos, S., Cipcigan, L. M., & Jenkins, N. (2009). Micro-generation for 2050: Life-cycle carbon footprint of micro-generation sources. In *2009 Proceedings of the 44th International on Universities Power Engineering Conference (UPEC)* (pp. 1–5). IEEE.
- Suh, S., et al. (2013). Interoperability between ecoinvent ver. 3 and US LCI database: A case study. *The International Journal of Life Cycle Assessment*, 1–9.
- Weidema, B. P., et al. (2013). *Overview and methodology: Data quality guideline for the ecoinvent database version 3*. Swiss Centre for Life Cycle Inventories.
- Weisbrod, A. V., & Van Hoof, G. (2011). LCA-measured environmental improvements in Pampers® diapers. *The International Journal of Life Cycle Assessment*, 17(2), 145–153.
- Whittaker, C., McManus, M. C., & Smith, P. (2013). A comparison of carbon accounting tools for arable crops in the United Kingdom. *Environmental Modelling & Software*, 46(C), 228–239.
- Wiedmann, T.O., et al. (2015). The material footprint of nations. *Proceedings of the National Academy of Sciences*, 112(20), 6271–6276.
- Wood, R., et al. (2015). Global sustainability accounting—developing EXIOBASE for multi-regional footprint analysis. *Sustainability*, 7(1), 138–163.

# Chapter 4

## Guidelines for Selection of Life Cycle Impact Assessment Software Tools



Daizhong Su, Zhongming Ren, and You Wu

**Abstract** To meet the demand for selection of suitable software tools of lifecycle impact assessment (LCIA) for sustainable design, ten popular LCIA software tools are reviewed, including CES EDUPACK, SolidWorks, Sustainable Minds, SimaPro, Gabi, openLCA, ECO-it, Umberto NXT LCA, EIME, and EarthSmart. Then they are analysed against three criteria regarding the *function to define the product and its lifecycle*, *databases*, and *assessment categories and available LCIA methods*. Based on the review and analysis results, guidelines for selection of the tools are proposed. With the guidelines and analysis results, an example is presented to illustrate how the guidelines are applied to select an LCIA software tool for sustainable design of an industrial gearbox.

**Keywords** Sustainability · Lifecycle impact assessment · LCIA · Sustainable design · Product design

---

D. Su (✉) · Y. Wu

Advanced Design and Manufacturing Engineering Centre, School of Architecture, Design and the Built Environment, Nottingham Trent University, Nottingham, UK  
e-mail: [daizhong.su@ntu.ac.uk](mailto:daizhong.su@ntu.ac.uk)

Y. Wu

e-mail: [you.wu@ntu.ac.uk](mailto:you.wu@ntu.ac.uk)

Z. Ren

School of Art and Design, Shanghai University of Engineering Science, No. 333 Longteng Road, Songjiang 201620 Shanghai, China  
e-mail: [zren@sues.edu.cn](mailto:zren@sues.edu.cn)

Shanghai Institute of Design and Innovation, Tongji University, No. 281 Fuxin Road, Yangpu 200092 Shanghai, China

## 4.1 Introduction

Sustainability, short for *sustainable development*, ‘is a concept describing mankind’s ability to create a world for humans and non-humans that environmentally, socially and economically provides for a current population’s needs without damaging the ability of future generations to take care of themselves’ (Blackburn 2007). Nowadays, sustainability has become an important consideration in product design. To conduct sustainable product design, the product’s impact on sustainability has to be assessed throughout its lifecycle, which is so called *product lifecycle impact assessment* (LCIA).

LCIA is normally a complicated process, and computer software tools are required to conduct the assessment. Currently, there are number of commercial LCIA software tools available in the market, Casamayor and Su reviewed more than 20 such tools, and more could be mentioned (Casamayor and Su 2013). There is a demand for guidelines to help the designers to choose suitable LCIA tools to effectively conduct sustainable design. To meet such a demand, this study analyses ten popular LCIA tools, including CES EduPack Eco audit tool (Granta Design n.d.), SolidWorks 2013 Sustainability tool (Dassault Systèmes n.d.), Sustainable Minds (Sustainable Minds n.d.), SimaPro 8.3 (PRé n.d.), Gabi 6 (GaBi thinkstep n.d.), OpenLCA 1.7 (GreenDelta n.d.), ECO-it 1.4 (PRé n.d.), Umberto NXT LCA 3.2.12.1 (ifu hamburg n.d.), EIME 5.3.0.8 (Bureau Veritas n.d.), EarthSmart (EarthSmart n.d.); and then provides guidelines how to select the tools for a particular design task.

The ten tools cover different LCIA categories, with assessment goals ranging from basic ones (carbon footprints and energy consumption) to a list of 18 mid-points impact and three end-points (human health, eco-system and resource); embedded assessment methods ranging from single one to 15 comprehensive ones; the tool categories including online tools, LCIA embedded in engineering material databases and a CAD package, and stand-alone specialized LCIA tools. Therefore, the analysis results and guidelines derived are suitable to a wide range of LCIA applications.

Sustainable design of gearbox is chosen as a case study in this research. Industrial gearboxes are essential mechanical products which have been widely applied in various fields. However, their design and manufacture are more focused on technical function rather than their impact on sustainability, and so far, LCIA has not been conducted for industrial gearboxes. This research is to fill this gap by conducting a full LCIA of gearbox. Due to its novelty, this case study has been chosen as an application scenario of myEcoCost project (Geibler et al. 2013), which is supported by the European Commission’s FP7 environment programme with nine partners across Europe. This case study has been disseminated via the project’s dissemination facilities across Europe and globally.



## 4.2 Review of the LCIA Software Tools

**CES EDUPACK** is a powerful tool for teaching materials and process, which has been widely used in higher education in engineering subject areas. CES EduPack provides a module called 'Eco-Audit tool' assessing ecological impact of products based on its powerful database built inside the package. After the user inputs materials, processes, transport and recycle information, the results of energy consumption and CO<sub>2</sub> footprints are then presented.

The most attractive feature of this package is its large database of materials and process information. Sustainability for Eco-design is included in the package alongside others functions in a wide range of engineering subject areas including general and mechanical engineering, manufacturing, materials science and engineering, industrial and product design, etc. This feature is particularly beneficial for material selection during design and conducting product LCIA.

Unfortunately, the database cannot be modified by the user, and the software package's function of eco-audit tool is limited. In product definition stage, only materials, primary process, and mass can be defined. There are only five selectable options which are landfill, down-cycle, recycle, re-manufacture, and reuse. Meanwhile, recycle content can be defined from 0 to 100%. Transport and use also can be defined based on the database. In the transport type, options are not diversified.

Also, the results of eco audit tool are limited to two eco-indicators (e.g. energy and CO<sub>2</sub> footprint) only, which comes from Eco Audit methodology from Granta, and the database of CES itself. The results of these two eco-impact values of five stages in product life cycle are presented as a bar chart, and corresponding data are shown in a table below the bar chart.

**SolidWorks** is a well-known 3D modelling CAD tool (Dassault Systèmes n.d.). A sustainability module is integrated into the package which can assess the sustainability of modelled parts or assemblies. After modelling a part or an assembly of several parts, the sustainability module can calculate the environmental impact of the part(s) or the assembly. The environmental impact indicators considered in the software include carbon footprints, water eutrophication, air acidification and energy. The results of these indicators are displayed as pie and bar charts in the result report.

In the package, a product can be defined by designer through CAD modelling and material selection. The product volume will be calculated by the software based on the model created, and the mass of the part is then obtained. After determining the processing method, it considers transportation from the region where the product is manufactured to the region where the product is used, and energy consuming between different locations. End of life scenarios are also considered. The package uses CML (Guinée 2002) and TRACI (Bare 2012) method and database of Gabi software, which is a widely-used life cycle inventory (LCI) database in Europe. SolidWorks employs the original database which cannot be modified by the user.

The impact distribution proportion of components is available in the results of SolidWorks. It provides a comparison between several parts or assemblies and determines which component has the most or least environmental impact. Unfortunately,

the results only show carbon footprints, water eutrophication, air acidification and energy, which may be not detailed enough for application in further design optimization. Besides, CAD modelling is requested before getting the sustainability report of a product. Sometimes the CAD modelling process is time consuming and a complex work, which delays the start of the LCIA.

**Sustainable Minds** is a Web-based sustainability assessment tool (Sustainable Minds n.d.). Its Web-based feature enables all the data used are stored in the server, so that the user can access his/her data all over the world through the Internet and an USB or mobile storage device are not necessary.

Before the evaluation starts, the designer must input material and part's manufacturing process, use, end of life, and transportation consumption. The process is similar to that of CES. All the LCI data is based on the database stored in the server and cannot be changed by customers. The results of Sustainable Minds are presented using point which is one single score representing ecological impact of the product. The methodology has been updated to SM 2013 Impact Assessment Methodology (Meijer 2013), which is a life cycle assessment methodology for evaluating potential ecological and human health impacts from products used in North America. SM 2013 calculates the ecological impacts from the ten impact categories outlined by Tool for the Reduction and Assessment of Chemical and Other Environmental Impacts (TRACI) (Bare 2012). It is designed for the user who is not a LCIA specialist, and the points are presented in the way easy to understand.

Nevertheless, the results may be not detailed enough for further in-depth analysis and the database cannot be modified. The data cannot be assessed if there is not an Internet connection. The Web-based features may make it run slowly in some cases and Internet access is required.

**SimaPro** is a well-recognised sustainability software package, with which the user can model and analyse complex life cycles in a systematic and transparent way, following ISO 14040 series recommendations (PRé n.d.). The package requires the user to build a life cycle of product and fill details in each stage of product life cycle such as material, process, transport, recycle, reuse and disposal; and then, the results of product life cycle network and ecological impact are presented.

In data collection stage, the user can input the amount of material, processes and relative data available in the huge databases built in the package (see Table 4.2), which are collected from a large number of sources related to variety of assessment methods as listed in Table 4.3. Furthermore, the database can be modified and extended based on customer's requirement. The user can add new material or process into the database and use it in his/her application. Function equations are also supported by SimaPro when the user adds new parameters or elements.

SimaPro also has the clear and precise presentation of results. The breakdown network of processes and materials is shown in Fig. 10.6 of Chap. 10. At the right side of each element of the presentation network, environmental impact indicator is illustrated as a red colour bar. The size of the colour bar indicates the scale of the impact: the larger one represents larger environmental impact of this element. Figure 9.10 of Chap. 9 shows an example that the comparison between the initial design of gearbox (red colour) with its optimized eco-design (green colour). This

function is helpful for designer to compare the LCIA of different products, which is particular useful for eco-design optimization.

**Gabi** is a well-recognised software tool for modelling products and systems from a life cycle perspective. Before LCIA process, the user should build a life cycle of the product in a graphic diagram. Based on the life cycle, the user defines inputs and outputs of material and energy for each stage; and then a sustainability report including resources and emissions is generated. Graphical construction of the life cycle is a noticeable feature to others. The life cycle modelling in Gabi is in a very clear way to illustrate and represent the whole life cycle of the product. It is similar to SimaPro which uses life cycle framework and generating network.

The Gabi database has been widely applied in various areas in Europe. It is created by PE INTERNATIONAL and includes over 7,000 lifecycle inventory profiles. Theecoinvent, US. LCI databases are also provided with the software. It contains all major impact assessment methods as listed in Table 4.3. Meanwhile, the user can modify and add elements into database and apply them when new lifecycle is to be modelled. The results provide detail data chart and inventories similar to those in SimaPro.

New version of the software significantly enhanced the presentation of the LCA results. The user can access all the results using different methods in one window. Also, customised chart can be generated based on the results. The user's chart option also can be saved for further use in other project. In addition, i-report module can produce report for user based on template embedded. Weak point function can determine where the weak point of the product life cycle is and highlight it in the results table.

**ECO-it** is a quick screening tool for designer who has no professional knowledge in LCA and want to consider environmental factor in their design including material and process selection (PRé n.d.). The life cycle assessment starts with creating a product life cycle. Within the life cycle, three phases, including production, use, and disposal, are provided for user to customise the life cycle of their product by adding material and process into these phases. The user can select proper or similar materials and processes from the embedded ecoinvent database. The LCA results can be obtained in real time, which is the key feature of a quick screening tool.

Due to the developer of the ECO-it is the same one developed the SimaPro, it can be defined as a light version of the latter. Limited database and methods are provided in comparison with SimaPro. Light version of ecoinvent database is the only data source, and ReCiPe (Huijbregts et al. 2016) and IPCC 2007 (IPCC 2014) are the only two LCIA methods can be used in the software. At the same time, these features make it runs smoothly and quickly. The results in forms of figure and chart display in real-time for user to check the sustainability of their design in second.

The developer published a tool called ECO-edit, which can be used to edit the database and method, for example, to modify the existing data, to create own data by user, or to developed own scoring system. It opens many possibilities for the application of the software.

**openLCA** is a free and open source LCA software developed by GreenDelta (GreenDelta n.d.) Users can purchase commercial databases, such as ecoinvent, and

get free LCIA method from official online shop. After importing these methods and databases into it, user can start the LCA. There is a structure list on the left side of the software interface and a few buttons on top of it. Most of the functions are accessed by them. First of all, the user should create a flow which represents the outcome of production, and creates a process referred to the flow. The process includes all input and output of the product lifecycle. These data can be selected from the embedded database. A product system should be created, which looks like a network between the product, and these inputs and outputs. In other words, it is a network between the flow and the process. The user can get the LCA results by clicking the calculate button, or they can go further to create a project which can compare two or more product lifecycle.

The most powerful feature is the openness of the openLCA. It is compatible with most of popular LCI databases and LCIA methods in the market which is listed in Tables 4.2 and 4.3. Owing to the Java based open source, the user is allowed to modify the functions of the software, which may include LCIA method, databases, representation of results, software interface. However, it is only feasible for user who has professional knowledge of Java.

On the other hand, the open source may bring bugs into the software. Sometimes, the results on the interface cannot be refreshed automatically. The user has to reopen the whole software to refresh the contents. Some of the interfaces and diagram look rough and not friendly to the user. Some of them may also have a compatibility problem which could make diagram or text looks irregular.

**Umberto NXT LCA** is a powerful and efficient LCA software with a comprehensive graphical lifecycle modelling (ifu hamburg n.d.). Flow chart and Sankey diagram of the product lifecycle are applied for user to understand the lifecycle modelling and LCA straightforward. The flow chart illustrates the relationships between elements and lifecycle phases. And the Sankey diagram shows the eco-impact flow of each elements in the lifecycle, which gives the user a clear and visual idea of the LCA results. The user can accomplish the modelling by drawing the diagram which shows input, output and process. Also, convenient function is available for the user, such as drag and drop, copy and paste.

After the modelling, the results can be quickly accessed through a simple chart with distribution of each lifecycle phase. Furthermore, the user can export LCIA results into a spreadsheet, which contains LCA raw data and customisable charts. The presentation of the results can be individualised by the user to express highly customised results. In addition, the software provides ecoinvent 3 and 20 Gabi databases, which are the most popular databases in the market. A number of familiar LCA method, such as ReCiPe (Huijbregts et al. 2016), Impact 2002+ (Jolliet et al. 2003), Eco-indicator 99 (Pré Consultants 2000), etc. are provided.

The downside of the software is hard to get started for user without professional knowledge of LCA. They will get lost in the complicated diagram of the lifecycle.

**EIME** is a widely used web application for environmental analysis (Bureau Veritas n.d.). The developer, Bureau Veritas CODDE, initially focussed on the electrical and electronics industries. User should set up information of the product in the beginning, such as weight, expected lifetime, functional unit and its ratio, etc.; secondly,

the user chooses one of the indicator set from Electricity and Electronics, Agro-foods, Textile, Aeronautic, Marine, ILCD—Level I and II recommended indicator (European Commission 2010) and Indicators for PEP ecopassport (PEP ecopassport n.d.). After preparation, product lifecycle can be modelled in five phases including manufacture, distribution, installation, use, and end of life. Remarkably, the modelling of transport and energy use are detailed in the software. In the analysis module, the user can read the results of LCA in a table which has numerical values in chosen indicator set and corresponding charts.

There are four different profiles for EIME users, designer, database manager, project manager, and administrator. Database and project management interfaces can be accessed by approved managers to manage relevant information. The results can be export into excel files or forward to email. The user interface is well designed and friendly. There is a notification centre shows operating status of the software and a clipboard for processes.

The software provides materials and processes, and other specified industrial databases developed or selected by the Bureau Veritas CODDE. The embedded indicator sets are different with other LCA tools. These factors may cause interoperability issue.

**EarthSmart** is a simplified web-based LCA tool based on the SimaPro (EarthSmart n.d.). Most functions of SimaPro can be accessed via the interface because the software is developed using COM interface of the SimaPro. It can be used by a group of users including managers, administrators, and users. The manager must approve what data can be used by others. And the administrator must prepare the database in SimaPro which will be used by users. The management feature enables hierarchical user access, which makes the user group well-organised. However, it also makes the software less flexible at the same time. If the database needs to be modified, only administrator can do it on the very top level of computer which installed the SimaPro.

LCA procedure begins with build module. In the module, the user create project, components or activities, and product life cycle successively. Number of products used can be defined, which enables repeated use and effect distribution of LCIA results. The results are the same as that in SimaPro. Report module is a practical function, which can generate LCIA report in word file following customised format.

The software's Web-based feature needs Internet connection, and the connection speed between the server and users must be enhanced, because it often takes time to switch functions. The data list is too short for user to navigate to desired data.

### 4.3 Analysis of the LCIA Software Tools

In this section, the strength and weakness of the above ten software tools are analysed in order to help the user to select suitable tools for his/her particular LCIA application. The analysis is based on the following issues: product lifecycle definition, assessment results presentation, databases embedded in the software tools, and assessment categories and available LCIA methods.

**Product and lifecycle definition.** Gabi and Umberto have the best product definition function because the lifecycle can be built through the user interface of lifecycle builder in a graphical way. SimaPro, openLCA are rated second, due to its comprehensive and flexible lifecycle structured framework. CES, EIME, and Sustainable minds both have similar rating for product definition function, which only defines limited number of elements in product lifecycle. SolidWorks can only define product via CAD modelling which is time consuming and complex work requiring professional knowledge. ECO-it and EarthSmart are developed based on the SimaPro, so the definition procedure of lifecycle is similar with it.

**Assessment results presentation.** SimaPro, Gabi, Umberto, openLCA, EIME and EarthSmart have similar presentation of results. Inventories and a set of charts give the user comprehensive and detailed LCA results. ECO-it has a real-time result view and auxiliary pie and bar chart. CES and Sustainable Minds both have similar report presentation which are bar and pie charts plus the data sheet, but sustainable Minds has impact distribution of different parts, which is clearer than that in CES. SolidWorks only has charts and simple data to present the results.

Table 4.1 summarises the comparison results of the software packages about the product and lifecycle definition and assessment result presentation.

**Databases.** Availabilities to use reliable databases and to select the databases suitable for a particular application highly affects the quality and accuracy of the assessment results. As shown in Table 4.2, SimaPro, Gabi, openLCA, Umberto, and EarthSmart have more availabilities for utilisation of databases and, hence, enable their potentials for high quality and accuracy of the assessments. In some applications, the required data may not be available in the databases embedded the software tools, and, hence, the tool's flexibility to allow the user to modify the databases or to add new data to the database are helpful.

**Assessment categories and available LCIA methods.** Based on their powerful and large database, SimaPro, Gabi, openLCA, and Umberto have the most details results, while other software tools, such as CES, SolidWorks, and Sustainable Minds do not have such detailed results of LCIA. SimaPro, Gabi, openLCA, and Umberto provide large number of assessment methods for the user to select, which enhanced their LCIA capacity. The assessment categories and available LCIA methods amongst the software packages are summarised in Table 4.3.

#### 4.4 Guidelines for Selection of the LCIA Tools

Based on the comparison results, the following guidelines are proposed for selection of the LCIA software tools for conducting sustainable product design.

- (1) For an engineering project where the materials are clearly identified, and the assessment is limited to energy consumption and carbon footprints only, then CES EDUPACK could be a good choice. The assessment could be conducted much quicker and easier than using other tools.

**Table 4.1** Product lifecycle definition and assessment result presentation

Packages	Definition of product and lifecycle	Presentation of assessment results
CES EDUPACK	Data input via tables	<ul style="list-style-type: none"> <li>Information with carbon and energy</li> <li>Results presented via bar and pie charts plus data sheets</li> </ul>
SolidWorks	<ul style="list-style-type: none"> <li>Product is defined via 3D CAD models</li> <li>Lifecycle data entered via tables and pull-down menu</li> </ul>	<ul style="list-style-type: none"> <li>Relatively detailed information available</li> <li>Results presented via pie charts, tables and the CAD model</li> </ul>
Sustainable Minds	Data input via tables	<ul style="list-style-type: none"> <li>Relatively detailed information available</li> <li>Results presented using pie and bar charts and data sheets</li> <li>Impact distribution of different parts, material or process</li> </ul>
SimaPro	<ul style="list-style-type: none"> <li>Data input via tables</li> <li>Lifecycle is defined via structured framework and the network based on the life cycle framework</li> </ul>	<ul style="list-style-type: none"> <li>Detailed information available</li> <li>Results are presented via network framework, tables and bar charts</li> <li>Better presentation of comparison between two products</li> </ul>
Gabi	Product is defined through a user-friendly lifecycle builder in a graphical way	<ul style="list-style-type: none"> <li>Detailed information available</li> <li>Results of different methods are presented in one window</li> </ul>
ECO-it	Data input via tables	<ul style="list-style-type: none"> <li>Results are presented in table and chart in real-time</li> </ul>
openLCA	Data input via tables	<ul style="list-style-type: none"> <li>Detailed information available</li> <li>Results are presented in charts and tables</li> </ul>
Umberto NXT LCA	Lifecycle is defined by drawing flow chart and Sankey diagram	<ul style="list-style-type: none"> <li>Detailed information available</li> <li>Results are presented in bar chart and one excel file which contains customised charts</li> </ul>
EIME	Data input via tables	<ul style="list-style-type: none"> <li>Detailed information available</li> <li>Results are presented in bar charts</li> </ul>
EarthSmart	Data input via tables	<ul style="list-style-type: none"> <li>Detailed information available</li> <li>Results are presented in the way as SimaPro</li> </ul>

- (2) If 3D CAD models have to be created for a design task, then the sustainability module of SolidWorks is a suitable tool to conduct the LCIA. However, the assessment has to be limited to the four Eco-indicators: carbon footprints, water eutrophication, air acidification and energy consumption.
- (3) Sustainable Minds has been designed for the users, who are not specialists of LCIA, in mind so the interface is easy to use and the analysis is also easy to

**Table 4.2** Databases of the LCIA software tools

Packages	Diversity of databases	Allow user to modify database
CES EDUPACK	Rich engineering material databases, but limited sustainability data for energy consumption and carbon footprints only	No
SolidWorks	Gabi LCA Databases for four indicators only (see Table 4.3)	No
Sustainable Minds	US-Ecoinvent database	No
SimaPro	Ecoinvent, US LCI, ELCD, US Input Output, EU and Danish Input Output, Swiss Input Output, LCA Food, Industry data v.2	Yes
Gabi	Gabi LCA Databases, ecoinvent, US LCI	Yes
ECO-it	Over 500 processes and materials from ecoinvent	Yes (ECO-edit required)
openLCA	ecoinvent and GaBi databases, ProBas, USDA, Ökobaudat, Social Hotspots, LC-Inventories.ch, NEEDS, ELCD, bioenergiedat	Yes
Umberto NXT LCA	ecoinvent and GaBi databases	No
EIME	Materials and processes, and other specified industrial databases developed or selected by the Bureau Veritas CODDE	Yes (for database manager)
EarthSmart	Same as the SimaPro	Yes (for administrator)

be carried out. It suits ‘what if’ scenarios which requires the assessment to be carried out fast, and high accuracy of the assessment is not crucial. It is particularly useful for evaluation of concepts during conceptual design, where the product information is not as detail as that available in detail design. The assessment result of single point makes the concept evaluation relatively simple, because each concept carries a single evaluation score and the concept with the highest score is obviously the best concept for selection. ECO-it is an ideal tool for concept design stage too. With showing results in real-time, the designer can get results as she/he modifies the data. The best concept can be easily and effectively obtained.

- (4) SimaPro, Gabi, openLCA, Umberto are comprehensive LCIA tools, which can be used to conduct full LCIA, for example, if ReCiPe method is used, 18 midpoints (such as Climate change, Ozone depletion, Terrestrial acidification, Freshwater eutrophication, etc.) and three end-points (eco-systems, human health and resource) impact can be assessed. The assessment requires a lot of high quality data which makes the assessment time-consuming. It requires the user to have experience in LCIA and specific knowledge of the product to be



**Table 4.3** The LCIA tools' assessment result category and available assessment methods

Packages	Assessment categories	Available assessment methods
CES EDUPACK	Energy consumption and carbon footprints	Granta Eco Audit methodology {TheCESEduPackEco:WZLUmUjl}
SolidWorks	Carbon footprints, water eutrophication, air acidification and energy consumption	CML and TRACI
Sustainable Minds	Ten impact categories	SM 2013 Impact Assessment Methodology
SimaPro	Various results related to the LCIA methods applied	ReCiPe, Eco-indicator 99, USEtox, IPCC 2007, EPD, Impact 2002+, CML-IA, TRACI 2, BEES, Ecological Footprint, EDIP 2003, Ecological scarcity 2006, EPS 2000, Greenhouse Gas Protocol
Gabi	Various results related to the LCIA methods applied	CML 200, EDIP 2003, Impact 2002+, ReCiPe, TRACI 2.1, UBP 2006
ECO-it	ReCiPe point and CO <sub>2</sub> eq	ReCiPe, and IPCC 2007
openLCA	Various results related to the LCIA methods applied	CML 2001, Eco-indicator 99, Ecological scarcity Method 2006, EDIP 2003, ILCD 2011, ReCiPe, TRACI, US EPA-default LCIA methods, and USEtox
Umberto NXT LCA	Various results related to the LCIA methods applied	Eco-indicator 99, Ecological scarcity Method 2006, EDIP 2003, IMPACT 2002+, IPCC 2007, TRACI, USEtox
EIME	Various results related to the LCIA methods applied	Electricity and Electronics, Agro-foods, Textile, Aeronautic, Marine, ILCD—Level I and II recommended indicator, and Indicators for PEP ecopassport.
EarthSmart	Various results related to the LCIA methods applied	CML 2001, EDIP 2003, ES Method, IPCC 2007, Packaging Impacts

assessed. Assessment results are quite accurate and reliable. As discussed in the above section, Gabi and Umberto have user-friendly graphical interface for definition of the product lifecycle, while SimaPro has better presentations for the comparison of assessment results. SimaPro and openLCA are suitable for the user who intends to use their own data or modified data from the database. These two software have great support for handling the database. openLCA also has a potential of second development. The user can develop their own LCIA platform based on the open source code of openLCA.

- (5) EIME and EarthSmart can be accessed via Internet and managed by approved users. These two are applicable tools for a company or a specified group of people to collaborate together. If the company can find desired data from the industrial databases provided by the EIME, it is a good choice. EarthSmart is a competent tool for a company which intends to obtain widely accepted results, because the SimaPro which can employ plenty of standard databases and LCIA methods stands behind it.
- (6) The software tools can jointly utilised in conducting a LCIA task. For example, in the example of eco-lighting product design (Casamayor and Su 2013) Sustainable Minds was used in conceptual design to evaluate the concepts' eco-features, while SimaPro was employed for detailed analysis of the eco-impact throughout the product lifecycle at the detail design stage.

## 4.5 An Example: LCIA Software Tool Selection for Sustainable Design of an Industrial Gearbox

Taking the industrial gearbox presented in Chap. 9 as an example, this section illustrates how a suitable LCIA software tool is selected, based on the guidelines and analysis results presented above.

The LCIA method ReCiPe is employed for LCIA of the gearbox, due to its capacity to conduct a full LCIA with end-point impact assessment of human health, ecosystems and resources. Since LCIA with ReCiPe is a very complicated task, a LCIA software tool has to be used. The following are considered in the LCIA software selection:

- Because full LCIA are to be conducted, comprehensive LCIA tools have to be considered. According to Guideline 4 given in the above section, SimaPro, Gabi, openLCA, and Umberto are selected as the candidate tools.
- Because there has not been a sustainable gearbox design found in the literature, new data for the design, which are not available in the existing databases, may be required. As mentioned in Table 4.2, SimaPro, Gabi and openLCA allow the user to add the new data into the assessment, which is another reason to choose the three packages.
- With a further consideration that the optimisation of the gearbox design is to be conducted, then SimaPro is finally selected because, because, as stated in Table 4.1, SimaPro has better presentation means of comparison between two products, an example of which is shown in Fig. 9.10 of Chap. 9.

## 4.6 Concluding Remarks

In this study, ten popular LCIA software tools are reviewed and analysed against three criteria regarding the *function to define the product and its lifecycle*, *databases*, and *assessment categories and available LCIA methods*. Based on the review and analysis results, guidelines for selection of the tools are proposed. LCIA is crucial for sustainable design, and there is a demand for guidelines to choose, therefore, the outcome of this research meets the demand.

The ten software tools reviewed in this study cover most types of LCIA tools, and, hence, the guidelines derived are generally applicable to most types of LCIA applications.

Following the guidelines and utilising the analysis results of this research, an example of sustainable gearbox design was conducted using SimaPro, one of the LCIA software tools reviewed in this study. Although industrial gearboxes have been widely applied in many fields, there has not been sustainable design of the products; therefore, the case study conducted in this research is a novel contribution to knowledge in the subject area.

## References

- Bare, J. (2012). TRACI 2.1: User manual. *US Environmental Protection Agency* (pp. 1–24).
- Blackburn, W. R. (2007). *The sustainability handbook*. London: Earthscan.
- Bureau Veritas. (n.d.). EIME life cycle assessment software. <https://codde.fr/en/our-software/eime-en/eime-presentation>.
- Casamayor, J. L., & Su, D. (2013). Integration of eco-design tools into the development of eco-lighting products. *Journal of Cleaner Production*, 47, 32–42.
- Dassault Systèmes. (n.d.). SolidWorks: 3D CAD design software. Retrieved 5 October, 2018, from <https://www.solidworks.com/>.
- EarthSmart. (n.d.). EarthSmart. Retrieved 5 October, 2018, from <https://www.earthshiftglobal.com/software/earthsmart-lca-software>.
- European Commission. (2010). *ILCD handbook: Analysis of existing environmental impact assessment methodologies for use in life cycle assessment*.
- von Geibler, J., et al. (2013). Forming the nucleus of a novel ecological accounting system: The myEcoCost approach. *Key Engineering Materials*, 572, 78–83.
- Granta Design. (n.d.). The CES EduPack Eco Audit Tool. Retrieved 5 October, 2018, from <http://www.grantadesign.com/education/eco/>.
- GreenDelta. (n.d.). openLCA. Retrieved 5 October, 2018, from <http://www.openlca.org>.
- Guinée, J. B. (2002). Handbook on life cycle assessment operational guide to the ISO standards. *The International Journal of Life Cycle Assessment*, 7(5), 311–313.
- Huijbregts, M. A. J., et al. (2016). ReCiPe 2016: A harmonized life cycle impact assessment method at midpoint and endpoint level Report I: Characterization, RIVM Report 2016-0104, National Institute for Public Health.
- ifu hamburg. (n.d.). Umberto. Retrieved 5 October, 2018, from <https://www.ifu.com/en/>.
- IPCC. (2014). Climate change 2014: Synthesis report. In *Contribution of working groups I, II and III to the fifth assessment report of the intergovernmental panel on climate change* (151 pp.). Geneva, Switzerland: IPCC.

- Jolliet, O., et al. (2003). IMPACT 2002+: A new life cycle impact assessment methodology. *The International Journal of Life Cycle Assessment*, 8(6), 324–330.
- Meijer, J. (2013). Sustainable minds: SM2013 methodology and database. Retrieved 5 October, 2018, from <http://www.sustainableminds.com/showroom/toto/SM2013-Methodology-Report.pdf>.
- PEP ecopassport. (n.d.). Find a PEP from PEP ecopassport. *Journal of Proteomics*, 108. Retrieved 5 October, 2018, from <http://www.pep-ecopassport.org/find-a-pep/>.
- PRé. (n.d.). ECO-it. Retrieved 5 October, 2018, from <https://www.pre-sustainability.com/about-pre>.
- PRé (n.d.). SimaPro. Retrieved 5 October, 2018, from <https://simapro.com>.
- Pré Consultants. (2000, October). Eco-indicator 99 manual for designers. *Ministry of Housing, Spatial Planning and the Environment*.
- Sustainable Minds. (n.d.). Retrieved 5 October, 2018, from <http://www.sustainableminds.com/>.
- thinkstep. (n.d.). *GaBi life cycle engineering suite* (pp. 1–4). Retrieved 5 October, 2018, from <http://www.gabi-software.com/uk-ireland/index/>.

**Part II**  
**Methods for Sustainable Product Design**

# Chapter 5

## Eco-Accounting Infrastructure



Daizhong Su and Wenjie Peng

**Abstract** Products produce negative ecological impacts, such as pollution on the environment, harmful gas emission, and negative impacts on eco-systems and human health. The ecological impact of a product can be measured with a numerical value called eco-point (EU H2020 CIRC4Life Project 2018), eco-score or eco-cost (von Geibler 2014). In this book, the ‘eco-point’ is used as a reference of the ecological impact values of products. In addition to the ‘*eco-point*’, the eco-point approach presented in this chapter also includes ‘*eco-debit*’ to show the customer’s negative ecological impact resulted from the products purchased, ‘*eco-credit*’ to credit customers’ positive behaviour of recycling end-of-life products, ‘*eco-shopping*’ for consumers to gain the ecological information of the products to be purchased, and ‘*consumer eco-account*’ to record consumers’ ecological footprints. The eco-accounting (or ‘ecological accounting’) infrastructure presented in this chapter includes the eco-point approach and the implementation of the eco-points, eco-debits and eco-credits, and their applications in sustainable production, eco-shopping, recycle/reuse and consumer eco-accounts. In this chapter, the eco-point approach is presented first, followed by the presentation of eco-accounting framework. To implement the eco-accounting framework requires large amount of dynamic data processing and management, and various information technologies, which are further presented in Chap. 6.

**Keywords** Eco-point · Eco-credit · Eco-debit · Eco-account · Ecological impact · Life cycle assessment · Life cycle impact assessment · Ecological impact

---

D. Su (✉) · W. Peng  
Advanced Design and Manufacturing Engineering Centre,  
School of Architecture, Design and the Built Environment, Nottingham Trent University,  
Nottingham, UK  
e-mail: [daizhong.su@ntu.ac.uk](mailto:daizhong.su@ntu.ac.uk)

W. Peng  
e-mail: [wenjie.peng@ntu.ac.uk](mailto:wenjie.peng@ntu.ac.uk)

## 5.1 The Eco-Point Approach

Eco-point is a cumulative value, which accounts for an aggregate of the ecological impacts throughout the product's whole supply chain. Eco-point is produced via utilising the method of life cycle impact assessment (LCIA). One of the most commonly used LCIA methods is ReCiPe (Golsteijn 2017), which applies seventeen midpoints and three endpoints to assess the impact of product and then produces a single score, i.e. an eco-point, as shown in Fig. 5.1. To obtain the midpoints and the endpoints, the following impact elements are considered: the impacts of materials used, production/manufacturing process, packaging, transportation and human labour involved in the production process, overhead of ecological cost, product service life, design for disassembly, product re-use, recycling, and disposal (Su and Ren 2011). The above impact elements are applied to the product's assembly, which is formed by the sub-assemblies with a number of components. The impact elements are utilised as the input parameters of LCIA method in order for calculating midpoints, endpoints, and eco-point.

In this research, the following new concepts and related methods are developed based on the eco-point:

- (1) **Eco-debit**, which is used to show the customer's negative ecological impact resulted from the products purchased. Within the eco-point approach, each product is associated with an eco-point, which is calculated through the product value chain, in which the use stage is included. The product eco-point is then converted to the consumer eco-debits. The eco-point is an absolute value. Considering that the eco-debit represents a negative impact, and in contrast with the eco-credit stated below, the eco-debit value is assigned with a negative sign '-'. For example, if the eco-point of a book is 9, then the eco-debit value of the book is -9.
- (2) **Eco-credit**, which is used to credit the customer's positive behaviour to recycle products which reach their end of life stage. In other words, customer will get the eco-credits when they recycle the end-of-life products. In contrast to the eco-debit, the eco-credit is a positive value, which reflects the positive behaviour of consumers via recycling/reuse activities. The eco-credits are calculated based on the eco-points, with a particular conversion, such as,

$$\text{eco-credits} = (\text{eco-points}) - (\text{consumed value}), \quad (5.1)$$

where the 'consumed value' indicates the reduced value in term of eco-point of the product during the product's use stage before the recycling.

In fact, the eco-credit value equivalent the product's remaining value accounted in eco-points. For example, if the original eco-point value of a book is 9; but after use of two years, the value of the book is reduced, i.e., the value of the book has

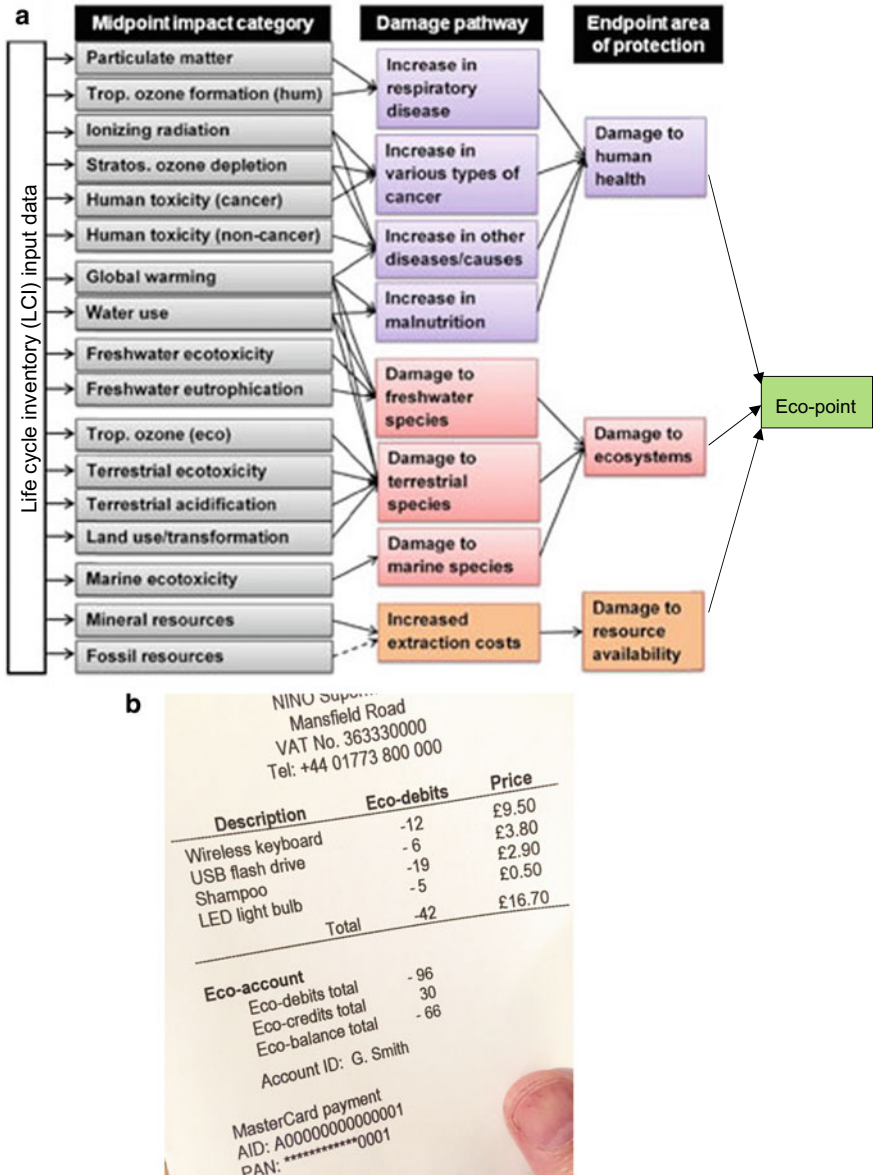

**Fig. 5.1** a Calculation of the eco-points based on the ReCiPe method. b The customer receipt showing the price and eco-account items of the products purchased



been consumed 2 eco-points when the product is recycled, then the eco-credit value of this book is accounted as

$$(\text{eco-point}) - (\text{consumed value}) = 9 - 2 = 7,$$

Please note that the above method to calculate the eco-credits is a simplified method. A comprehensive method is presented in (CIRC4Life D2.4 Team 2019).

In practice, the eco-credits could be paid in cash or its equivalent to the users. The eco-credits could also be used to encourage a retailer to participate in recycling, for example, when a meat retailer (shop or supermarket) recycles their expired meat products, the eco-credits could be paid via a discount that can be applied to the purchase of new meat products (EU H2020 CIRC4Life Project 2018).

- (3) **Consumer's eco-account**, which is to record consumers' eco-debits and eco-credits related to purchasing and recycling activities and, hence, it enables consumers to record and track their daily footprints on environment. As stated in the above (1) and (2), the eco-debits show the consumer's negative impact footprints generated through the acquisition of products, while the eco-credits show the consumer's positive behaviour through recycling. Within the consumer's eco-account, the product's eco-debits are traded off by eco-credits; in other words, the eco-debits can be offset with the eco-credits which the consumers earn via recycling their products. Finally, the eco-balance is calculated based on the sum of the eco-debits and eco-credits earned, resulting in the value of eco-balance i.e.

$$\text{eco-balance} = (\text{eco-debits}) + (\text{eco-credits}) \quad (5.2)$$

which reflects the consumer's overall impact footprints, as shown in Table 5.1.

In the table, the book's eco-debits and eco-credits are obtained from the example shown in (2) above, and the eco-balance value is obtained from the calculation below

$$\text{eco-balance} = (\text{eco-debits}) + (\text{eco-credits}) = -9 + 7 = -2$$

As for the computer shown in the table, according to the results obtained in Sect. 5.2 (3), its eco-debits = -18, eco-credits = 13, and, hence, eco-balance = -5.

**Table 5.1** Example of a consumer eco-account page

Products	Eco-debits (via purchasing)	Eco-credits earned (via recycling)	Eco-balance
Computer	-18	13	-5
Book	-9	7	-2
Total	-27	20	-7

- (4) **Eco-shopping**, which enables consumers to view the eco-points and sustainable manufacture information of products using their smartphones in the stores. Consumers can scan the RFID/NFC tags embedded in the products placed on the store shelf to obtain the product’s sustainable information, which will facilitate the consumers to select more sustainable products (*for more information about ‘eco-shopping’ please see Sect. 6.4.3*).

The ‘eco-point’, ‘eco-debit’, ‘eco-credit’, ‘eco-account’ and ‘eco-shopping’ have been developed/utilised in the eco-accounting infrastructure, with the special concerns on the product’s sustainability, which are detailed in Sect. 5.2.

## 5.2 The Eco-Accounting Infrastructure

The function of the eco-accounting infrastructure is to implement the information and communication technologies (ICT) to collect and process the data for the calculation of eco-points, and then apply the eco-points obtained into the different areas, with the special concerns of sustainability, including eco-shopping, recycling/reuse, consumer’s eco-account, and product sustainability assessment, as shown in Fig. 5.2.

Within the eco-accounting infrastructure, a large amount of dynamic data are captured from the product supply chain, in order to provide the inputs for the calculation of eco-points. Subsequently, the life-cycle assessment (LCA) is conducted utilising the LCA method and related commercial tools. With the Web-based user interfaces, the commercial LCA tools, such as openLCA ([www.openlca.org](http://www.openlca.org)), are enabled to online calculate the eco-points with the data bridging method (*for more information about the data bridging please see Sect. 6.7*). Based on the eco-points obtained, the eco-debits and eco-credits are developed, which reflect the consumers’ negative and positive impacts on the environment, respectively.

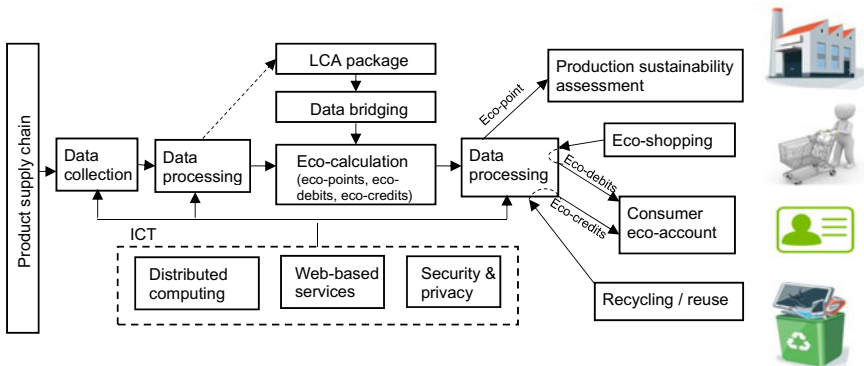

Fig. 5.2 The eco-accounting infrastructure



**Fig. 5.3** Scanning the embedded RFID tag in the product with the smartphone in order to obtain the product's eco-points

The eco-accounting infrastructure, which is supported by the ICT, provides the following functions/applications:

- (1) *Application of the eco-debits in the eco-shopping.* In the store, the consumer utilises the smartphone to scan the RFID tag embedded in the product to view the eco-points of the product, as shown in Fig. 5.3. By comparison of different product's eco-points, the consumers can select more sustainable products. To do so, product's information, including product's serial number, eco-points and sustainability related information such as manufacture, energy consumption and source of materials, are encoded into the micro-chip of RFID tag with the product in advance. Further, the mobile phone app is utilised for consumers to view the eco-debits from the RFID tag with their mobile phones. The mobile app involves the graphic user interfaces showing the product's eco-points and sustainability information, the code of the access to the RFID tag, and data management.

When the consumer pays the products at the check-out point in the store, the products' eco-debits resulted from purchasing are recorded in the consumer's eco-account. To achieve this, the identity of consumer has to be validated first. The consumer's identity (ID) is usually indicated by the personal identification code, which is a set of numbers obtained by encrypting the serial number of a mobile phone. The personal identification code is stored in the chip of a NFC-enabled smartphone, which is used for customer's authentication. The consumer utilises the smartphone to scan the NFC reader at the check-out point and then signs into their eco-account. Subsequently, the eco-debits of the product purchased are recorded into the consumer's eco-account (*for more information about consumer's sign-in please see Sect. 6.3.1*).

- (2) *Application of the eco-credits in consumer's electronic product recycling.* When the consumers' electronic products come to the end-of-life (EoL), they recycle the products and then get the eco-credits, which incentivise the consumers to participate in the recycling activities. The consumers can view the eco-credits

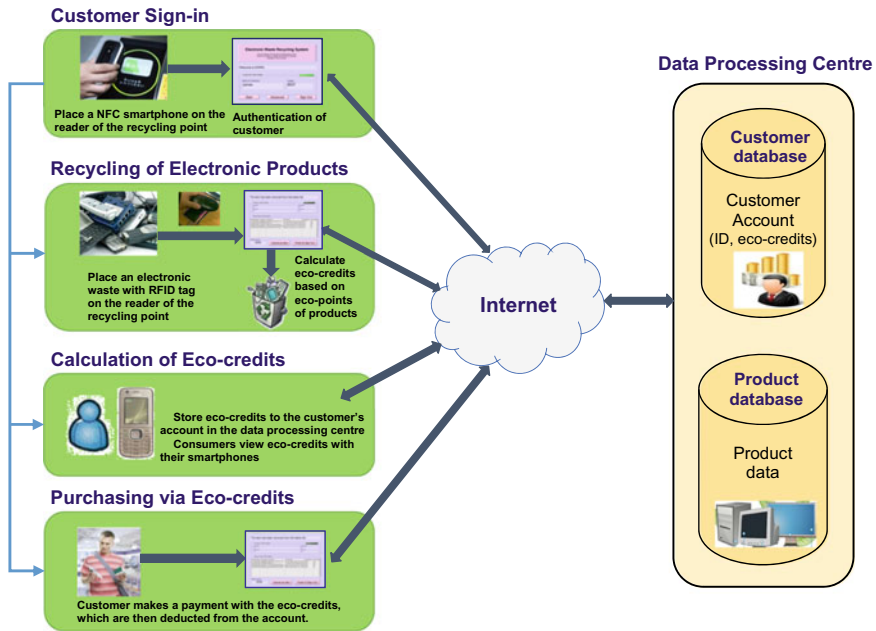

Fig. 5.4 Consumer’s electronic product recycling and purchasing via eco-credits

obtained through recycling the products from their eco-accounts. The eco-credits could be paid in cash or the equivalent to the consumer, which will be used for purchasing new products. The system consists of the following parts: consumer sign-in, electronic product recycling, eco-credit management, and payment via eco-credits, which are detailed below and illustrated in Fig. 5.4:

- **Consumer sign-in**, which is to validate the consumers’ ID and allow the authorised consumers to enter the system. The consumer’s ID is identified by the personal identification code, which is integrated into a NFC chip of the smartphone for customer’s ID verification. While a consumer places a NFC-enabled smartphone on the reader at the recycling point, the personal identification code is retrieved by a self-service monitoring computer, which is sent to the data processing centre over the Internet. Once the authentication is successful, the customer is enabled to log in the eco-account for recycling their EoL electronic products (*for more information about consumer’s sign-in please see Sect. 6.3.1*).
- **Consumer electronic product recycling**, which starts by verifying the serial number of an electronic product. The serial number, as the unique identifier of the electronic product, is used to identify the product and obtain the information of products. The serial number is stored in the RFID tag embedded in the electronic product. When a consumer places an electronic product on the reader at the recycling point, the serial number is retrieved from the RFID

tag of the electronic product and then sent to the data processing centre to obtain the product data. According to the serial number, the product data are fetched by matching this number with records of product data within the product database. The product data includes product ID (serial number), product description, eco-points and other eco-information (*for more information about the development of consumer's product recycling please see Sect. 6.3.2*).

- **Calculation of eco-credits.** Based on the product's eco-points gained, the eco-credits are calculated. The calculation of the eco-credits are implemented in the data processing centre remotely. The more electronic products the customers recycle, the more eco-credits they will gain. When recycling all the electronic products, the eco-credits of total products are saved into the customer's eco-account. The eco-credits available in the eco-accounts can be viewed by the consumers' smartphones.
- **Purchase with eco-credits.** The eco-credits can be spent in the form of electronic money, also known as virtual money. When customers go to the store, they could pay the products with the eco-credits. Firstly, the consumers log into the system using their smartphone; and then they scan the serial numbers of products which they intend to purchase via a RFID reader in the self-service payment point. The serial numbers of products are sent to the data processing centre for calculating how many eco-credits are required to pay the products. After scanning all the products, the consumer make the payment with the eco-credits, which are then deducted from the customer's eco-account. If the eco-credits are not enough, the payment will either be advised to pay via cash, or be cancelled.

(3) *Application of eco-credits and eco-debits in the consumer's eco-account.* The eco-debits obtained via purchasing the products and the eco-credits obtained via recycling the products are recorded in the consumer's eco-account. The eco-debits show the consumer's negative impacts via the acquisition of products, which are negative values; while the eco-credits show the consumer's positive impacts through recycling and reuse, which are positive values (*for more information about the eco-debits and eco-credits please see Sect. 6.1.1(1) and (2)*). Then, the sum of the eco-debits and eco-credits is calculated to obtain the eco-balance, which is recorded in the eco-account. The following example shows the procedure how to calculate eco-debits, eco-credits, and eco-balance of a 'computer' product:

- (i) The eco-points of a computer are obtained as 18, via the assessment of the environmental impact through the product's life cycle.
- (ii) When a consumer buys the computer, he/she gets the eco-debits  $-18$
- (iii) When the computer comes to its EoL, and the consumer recycles this computer, then the consumer is awarded with eco-credits, which can be calculated using Eq. (6.1) shown in Sect. 6.1.1 (2). According to Eq. (6.1), the eco-credit value is related to the 'consumed value', which is due to the use of the computer throughout its use stage. The determination of the

‘consumed value’ involves various parameters, such as the depreciation cost and the environmental cost produced in the whole use stage, which have to be calculated in individual cases. To simplify the illustration, the consumed value of this example is 5, then the eco-credit value of the computer is calculated using Eq. (6.1) as follows

$$\text{eco-credit value} = (\text{eco-point value}) - (\text{consumed value}) = 18 - 5 = 13$$

- (iv) With the eco-debits and eco-credits obtained, the eco-balance is calculated as:

$$\text{eco-balance} = (\text{eco-debits}) + (\text{eco-credits}) = -18 + 13 = -5$$

- (v) The computers eco-debits, eco-credits and eco-balance values are then recorded in the consumer’s eco-account as shown in Table 6.1 in Sect. 6.1.1.

The following aspects are considered during the development of consumer’s eco-account:

- *Specification of the data contents/types in the consumer eco-account.* Usually, there are a wide range of data related to products’ eco-debits, such as quantities and units of the purchased products. Consumers can retrieve the information through their mobile phones by quickly scrolling the recorded product list shown in the mobile devices. Once a product item is selected by the consumer, the mobile phone app can display the eco-debits of the selected product (*for more information about the view of eco-debits via mobile phone please see Sect. 6.7.4*).
  - Consumers can easily get the eco-debit data when they purchase by scanning the RFID tag of the electronic products, and earn the eco-credits when they recycle through scanning the RFID tags of the electronic products (e.g. lighting products, tablets). The aim is to develop the scanning functions which enable the RFID reader to access and interpret the data within the RFID tag and to communicate with the records of the consumer’s eco-account.
- (4) *Application of eco-points in the production sustainability assessment.* The eco-point value is used as an indicator to assess the product’s sustainable impact throughout the production process. Relevant aspects, which affect the eco-point values, within the production process, are investigated in order to reduce the eco-point value, and then necessary sustainable production methods are identified and then implemented in the production. The major aspects to be considered to reduce the product eco-point values during the sustainable production include:
- Identify and implement production processes with reduced impacts. Processes that reduce the use of materials, energy, water, greenhouse gas emissions, and reduce production of waste will be focussed on in particular.
  - Eco-procurement.
  - Sustainable product development methods, such as design for recycling and reuse for electrical and electronic products, and carbon sequestration in

farm soils and biomass to reduce atmospheric carbon dioxide levels, will be investigated and utilised in the production process.

- Identify innovative businesses and business practices that pushes boundaries on sustainable production and implement them in the production process.
- Develop new services to enhance sustainable production, for example, leasing products to end-users of the LED lights, and new methods of retail in food products.

(5) *Application of ICTs for collecting and processing large amount of dynamic data for the eco-point calculation.* In order to calculate the eco-points, a large amount of dynamic data are involved. The dynamic data are usually dispersed in different locations through the product supply chain. In order to capture/process the data in relation to the calculation of eco-points, the following information technologies are required:

- **Distributed computing**, which deals with massive real-time dynamic data to be collected from multiple operation models of the product supply chain (e.g. raw material companies, manufacture companies, etc.), in order to obtain the data for the calculation of product’s eco-points, as shown in Fig. 5.5. With the distributed computing technology, multiple server computers are utilised for allocating the computing tasks, in order to balance the computing workloads of each computer. A number of computing tasks are processed, including querying, fetching and storage of real-time data related to eco-point calculation of products (*for more information about the development of the distributed computing technology please see Sect. 6.1 of Chap. 6*).

**Fig. 5.5** Process real-time dynamic data across different computers

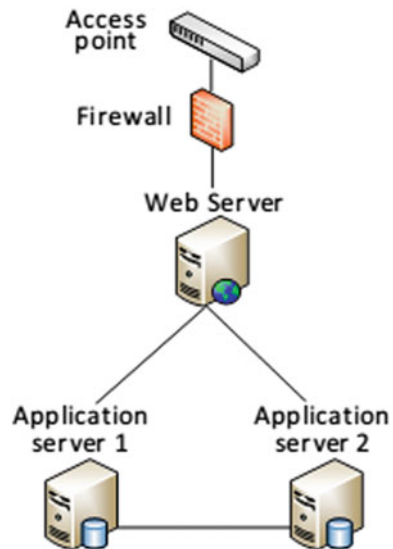

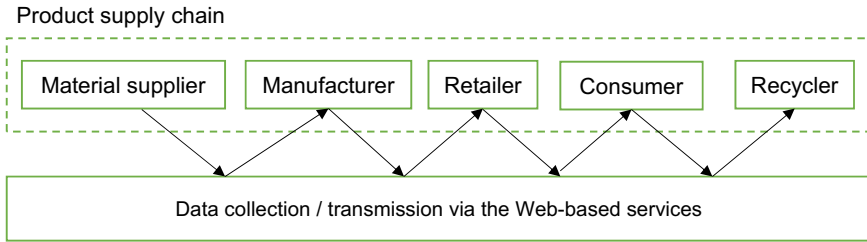

**Fig. 5.6** Data collection with the Web-based services

- **Web-based services**, such as software interface service and user registration/login service. The software interface service provides the interfaces for collecting the data from the operation models in the supply chain, and transmitting the data for the eco-point calculation from one operation model to another, for example, from a raw material company to a manufacture company, throughout the products' life cycle (see Fig. 5.6). The user registration/login service is used to authorise the company to log in as a user in the system, in order to upload the data required for the eco-point calculation (for more information about the Web-based services please see Sect. 6.2 of Chap. 6).
- **Data security**, to provide the protection of data and user privacy when they are transmitted throughout the whole supply chain. The digital encryption ensures the data transmitted are not tampered and leaked through the network, including the Internet, Intranet, and all the other server-based system/applications. The integrity of data transmitted is guaranteed because every link, such as from material extraction to manufacture, is controlled within the transmission process (for more information about the data security method please see Sect. 6.4 of Chap. 6).

### 5.3 Conclusion

This chapter presents an eco-point approach which further developed the eco-point method with new concepts of eco-debits, eco-credits, consumer eco-account, and eco-shopping, which have the following advanced features:

- The eco-debits indicate the consumers negative impact resulted from consuming products, while the eco-credits award the consumer's recycling EoL products. Both the eco-debits and eco-credits are recorded into the consumer's eco-account, resulting in the eco-balance which shows the combined effects of the consumption and recycling of products.



- The eco-shopping enables the consumer to get the eco-pints and eco-information of the products, which enable the consumer to make a decision to purchase more sustainable products.

The outcome of this research made the following novel contributions to implement the circular economy:

- The consumer eco-account with eco-debits/credits and eco-balance, and its combination with eco-shopping have not been seen in the literature, and, hence, it is a new and valuable attempt to alert the consumers with their ecological footprints.
- The eco-accounting framework enables the implementation of the eco-point approach throughout the process data of collection and processing into the sustainable production assessment, eco-shopping, consumer eco-accounting and recycling/reuse. This a valuable means for both industry and consumers.

The eco-point approach and the eco-accounting framework have been accepted by the CIRC4Life project supported by the European Commission's Horizon 2020 circular economy programme. They are currently in the process of refinement and application in four industrial demonstrators of vegetable farming, meat supply chain, LED lighting products and recycling/reuse of computer tablets. For further information, please see (EU H2020 CIRC4Life Project 2018).

**Acknowledgements** The authors acknowledge the financial supports received from European Commission for the FP7 myEcoCost project (grant number 308530), which provided the basis for the development of the eco-point approach and the eco-accounting framework, and the H2020 CIRC4Life project (grant agreement number 776503) for refinement and application of the approach and framework.

## References

- CIRC4Life D2.4 Team. (2019). Eco-credits method final definition. CIRC4Life project deliverable 2.4. Retrieved December 2019, from <http://myntuac.sharepoint.com/sites/CIRC4Life>.
- EU H2020 CIRC4Life Project. (2018). CIRC4Life: A circular economy approach for lifecycles of products and services. Annex 1 of Grant Agreement, grant agreement number-776503-CIRC4Life, European Commission Horizon 2020 Programme.
- Golsteijn, L. (2017). Updated Impact Assessment Methodology ReCiPe2016. Retrieved July 2018, from <https://simapro.com/2017/updated-impact-assessment-methodology-recipe-2016/>.
- von Geibler, J., et al. (2014). Forming the nucleus of a novel ecological accounting system: The myEcoCost approach. *Journal Key Engineering Materials*, 572, 78–83. ISSN 1013–9826.
- Su, D., & Ren, Z. (2011). Ecological impact assessment and Eco-design of industrial gearboxes. *Key Engineering Materials*, 486, 197–200 (2011).

# Chapter 6

## Application of Information and Communication Technologies for Eco-Accounting



Wenjie Peng, You Wu, and Daizhong Su

**Abstract** The function of the eco-accounting is to measure the ecological impact of product, or called eco-point, throughout product's life cycle. In the eco-accounting, large amounts of dynamic data are to be captured for the calculation of eco-point. In order to obtain the data, the Information and communication technology (ICT) is required to collect dynamic data for the calculation of eco-point, and then make them accessible for all stakeholders along the value chain, from one operation model to another, for example, from material extraction to product manufacture and from supplier to customer, in order to measure the product's eco-point. Based on the eco-point, the eco-debit and eco-credit are obtained, which are applied in the different areas with major concerns on sustainability, such as production sustainability assessment, eco-shopping, recycling, and consumer's eco-account.

**Keywords** Information and communication technology · Sustainability · Ecological impact · Eco-accounting · Life cycle assessment · Product development

### List of Abbreviations

ICT	Information and Communication Technology
DC	Distributed Computing
XML	Extensible Markup Language
JSON	JavaScript Object Notation
REST	Representational State Transfer
LCA	Life Cycle Assessment

---

W. Peng (✉) · Y. Wu · D. Su  
Advanced Design and Manufacturing Engineering Centre, School of Architecture,  
Design, Build Environment Nottingham Trent University, Nottingham, UK  
e-mail: [wenjie.peng@ntu.ac.uk](mailto:wenjie.peng@ntu.ac.uk)

Y. Wu  
e-mail: [you.wu@ntu.ac.uk](mailto:you.wu@ntu.ac.uk)

D. Su  
e-mail: [daizhong.su@ntu.ac.uk](mailto:daizhong.su@ntu.ac.uk)

HTTP	Hypertext transfer protocol
HTTPS	Hypertext transfer protocol secure
LCIA	Life Cycle Impact Assessment
LCI	Life Cycle Inventory
TCP	Transport Control Protocol

The eco-accounting infrastructure is presented in Chap. 5, while the utilisation of various ICTs for implementation of the eco-accounting infrastructure is presented in this chapter. Within the eco-accounting infrastructure (see Fig. 5.2 of Chap. 5), the three fundamental ICTs (distributed computing, Web-based services and security and privacy) are covered by Sects. 6.1, 6.2 and 6.4, and the data bridging for online LCA is dealt with in Sect. 6.6. The necessary NFC, RFID and mobile communication technologies are presented in Sect. 6.3, which are utilised for customer's ID verification, electronic product recycling and eco-shopping. The design of the software structure is presented in Sect. 6.5.

## **6.1 Distributed Computing for Handling Dynamic Data for Eco-Point Calculation Across Multiple Computers**

There are considerable amounts of real-time dynamic data for the calculation of eco-points to be dealt with in various types, such as text information, numeric data, array, charts, images, etc. Those data are usually dispersed geographically in the different locations, for example, a LED driver's manufacture company in London, and a company for LED light assembly in Manchester. To deal with those dynamic data from different locations effectively, it is essential to develop a distributed computing environment by means of a centralised 'server cluster' (Microsoft technical documentation 2001), responsible for processing the data flow through the eco-accounting system. In this book, the server refers to a host control system that can be accessed or controlled by the client side, i.e. a company or consumer. Several servers that communicate with each other make up a 'server cluster', which makes a set of services highly available to client sides.

### **6.1.1 Overview of Distributed Computing**

Distributed computing, also called distributed processing, is a key technology that is used in grid computing. Since the spectrum of grid computing is too much broad, it is very important to distribute the computing tasks to multiple server computers, in order to balance the workload of computing tasks across the nodes of the network.

The above-mentioned computing tasks mainly include processing of dynamic data for the calculation of product's eco-point, such as data querying, fetching and storage.

In general, a distributed computing system consists of a Web server computer and more than one application server computers for distributed computing. The Web server is used to receive requests/instructions from different companies or consumers over the Internet, and subsequently allocate the task to the application servers for further processing. The Web server and application servers form a server cluster, in order to provide computing services for client sides.

To optimise the use of system resource, the Web server can intelligently select a computer within the network to perform the computing task specified, with the following two methods:

(a) Utilisation of computer usage

The Web server monitors the resource usage of every server computer located at each node of the network, such as CPU (central processing unit) usage, memory usage and amount of computing tasks of the computer. Then the Web server assigns a particular task to a computer with the lowest usage for further data processing. This method is often applied in distributed computing for grid network, in order to optimise the data flow, and to reduce the stacking of workloads of network.

(b) Round-robin processing

The Web server allocates the task to a server computer at the node of network in random or a sequential manner. In this case, the computer selected will not be considered if it has adequate operation resource. We call this method as 'Round-robin processing' (Su and Peng 2015).

Based on the above-mentioned (a) or (b), an 'optimal' application server is selected to perform the computing tasks, including resolving the user's request, data querying, and storing the data in the Web server. Then the Web server transmits the data obtained to the company located at the next stage of the supply chain, utilising the software interfaces developed (*for more information about the software interfaces please see Sect. 6.3.1*).

### ***6.1.2 Development of the Distributed Computing System***

According to the amount and scale of the dynamic data to be captured over the Internet, there are three types of distributed computing systems:

- (1) *Small distributed computing system*, which contains a Web server and two application servers. Each application server works on an individual computer to deal with data separately. Within this system, there is no stand-alone server for uniformly managing all the data, and each application server includes a local database instead. This requires that the application servers have to communicate each other, in order to ensure that the databases of the two application servers are

synchronised in real time to fill in the missing data within respective database. For example, when one application server receives new eco-point data, the other application server will also receive the same data. In this way, the new data can be kept in the databases of the both application servers. When a task involves querying of the new data, then either of the application servers will be selected by the Web server to execute this task. Figure 6.1a shows a basic distributed computing system, where each application server includes an individual local database.

- (2) *Medium-sized distributed computing system*, which is designed for medium-scaled network communication. It includes a Web server, two application servers, and a database server. The Web server distributes the computing task to an application server, and then the application server interacts with the database server to perform the task, such as data querying. The distribution process is to be conducted according to the actual computer's usage and tasks progressing in the application servers. For example, the Web server allocates a data querying task/instruction to the application server with lower usage, which then retrieves the necessary data from the database server. Compared with the basic distributed computing system presented in above (a), this system contains a stand-alone database server, which is used to uniformly manage the data in the centralised manner. In addition to this, the application server has a local database for exchanging temporary data and files. Figure 6.1b shows the distributed computing system with a central database server, which is used for uniformly managing all the dynamic data.
- (3) *Large-sized distributing computing system* capable of handling huge amount of data, which includes several computing resources (processors, memories and storage). This system is made of several on-demand Web servers, application servers, and database servers. When massive computing tasks are to be dealt with at the same time, more computing resource are required (Isard et al. 2007). Therefore, it is important that such an ICT infrastructure has scaling-up capability, i.e. accommodating new server computers to enhance the power of processing and storage. The new computing resource is allowed to be combined with the existing resource within the eco-accounting system, in order to ensure that server computers at network nodes can communicate each other and every computer works normally. This requires that all the server computers are installed with the identical operation system and software, and have relevant computer configurations and functions. Figure 6.1c is the extension of Fig. 6.1b, which shows the scaling capacity of distributed computing in order for dealing with large numbers of data. Benefited from the scalable distributing computing feature, the system is expected to be able to process thousands and even millions of dynamic data related to the eco-point per day.

The server computers that operate within the system have to comply with the following development criteria, in order to ensure the distributed computing system functions effectively:

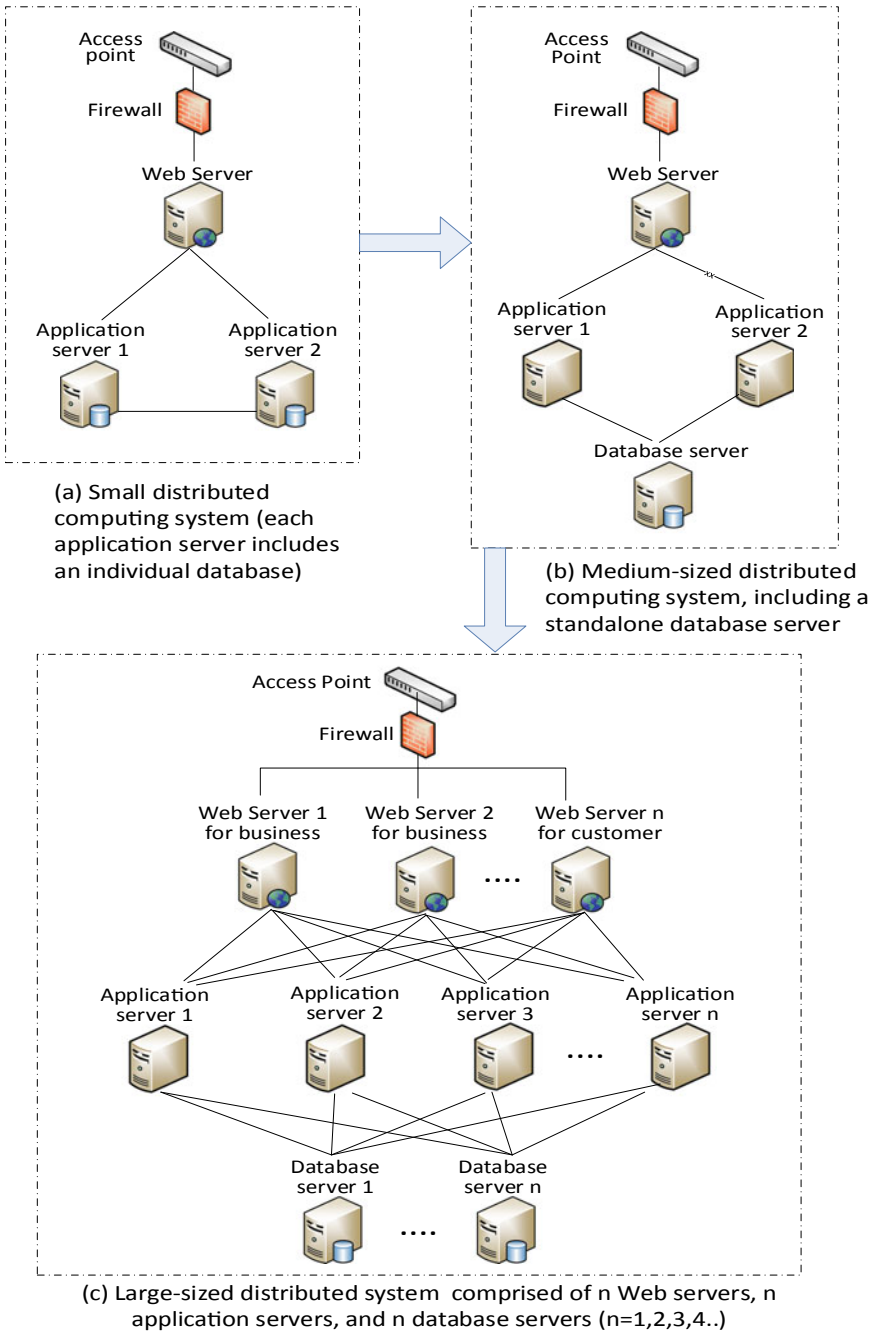

Fig. 6.1 Types of the distributed computing system

- (i) Each server (Web server, application server, and database server) is exclusive to an individual computer. That is, a Web server can only work on one computer, where the application server and database server cannot be installed.
- (ii) The Web server has three functions: (a) to receive the requests/instructions from the company client or consumer clients over the Internet; (b) to allocate the computing tasks to different application server computers to process the requests; and (c) to transmit the processed results to the company/consumer client. The Web server does not execute any specific computing task, but delivers it to the application server instead.
- (iii) The application server performs specific computing tasks which are allocated by the Web server. Usually, when the Web server receives a request, it then allocates the tasks by a means of judging the computer usage or round-robin processing. Subsequently, the application server interacts with the database server, and transmits the result to the Web server. This requires that all the application servers are installed by the identical operation system and relevant application software, in order to ensure all the application servers have the same functions and applications.
- (iv) The database server interacts with the application server via internal interface (Su and Peng 2015). It is important that the Web server is not allowed to link to the database server without going through the application server.

### ***6.1.3 Case Study: Massive Dynamic Data Processing Across Different Computers***

This case study illustrates the operation of a typical small distributed computing system, which includes three computers: a Web server and two application servers. Within this case study, the Web server works as a central controller to allocate a request/task of handling the dynamic data for calculating the product's eco-point, which is acquired from a company online, to an 'optimal' application server; then the application server interacts with the database server to perform the task (i.e. querying and retrieving data from the database), and transfers the data obtained to the Web server.

This system has the capability to deal with the complicated interactive situation. For example, when multiple companies and consumers connect to the Web server at the same time, a large number of requests/instructions have to be dealt with simultaneously. This system can effectively handle those different requests, to prevent from unexpected 'bottle-neck' phenomenon of the servers, such as full CPU loads resulting in program failure (Su and Peng 2014). First of all, the Web server is enabled to track the usage of each application server; and then the Web server assigns the computing tasks in time to a lower usage application server. Here, the lower usage refers to that this application server is running fewer tasks, and hence, has a higher idle rate than other application servers.

Figure 6.2 shows the utilisation of hardware resource of server computers, including total CPU usage, usage of every CPU core, memory usage, and the duration of CPU and memory. The usage of each application server can be obtained via accessing the computer hardware information from the Registry of the operation system, which is a tool of the management of computer resource allocation.

Each server computer works as a ‘node’ within the network, which is formed by the three server computers. As a ‘controller’ of the nodes, the Web server can track the

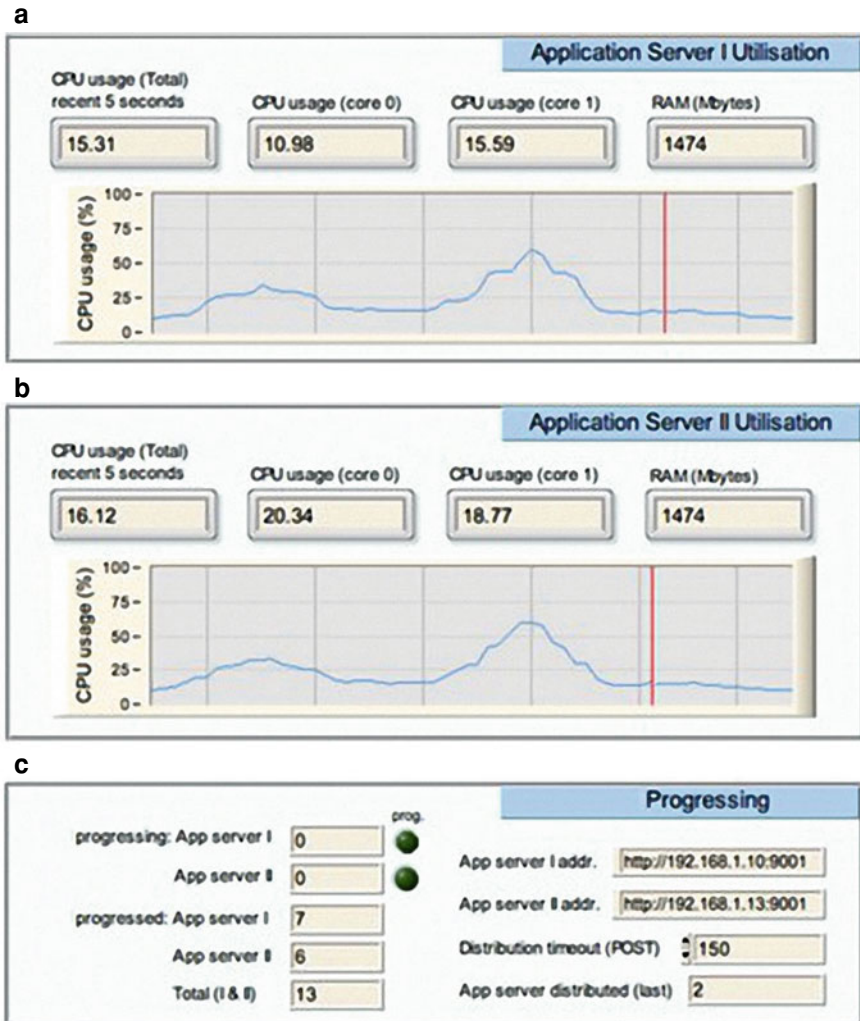

**Fig. 6.2** a Usage of computer resource of the first application server computer. b Usage of computer resource of the second application server computer. c Information of computing tasks allocated on the server computers



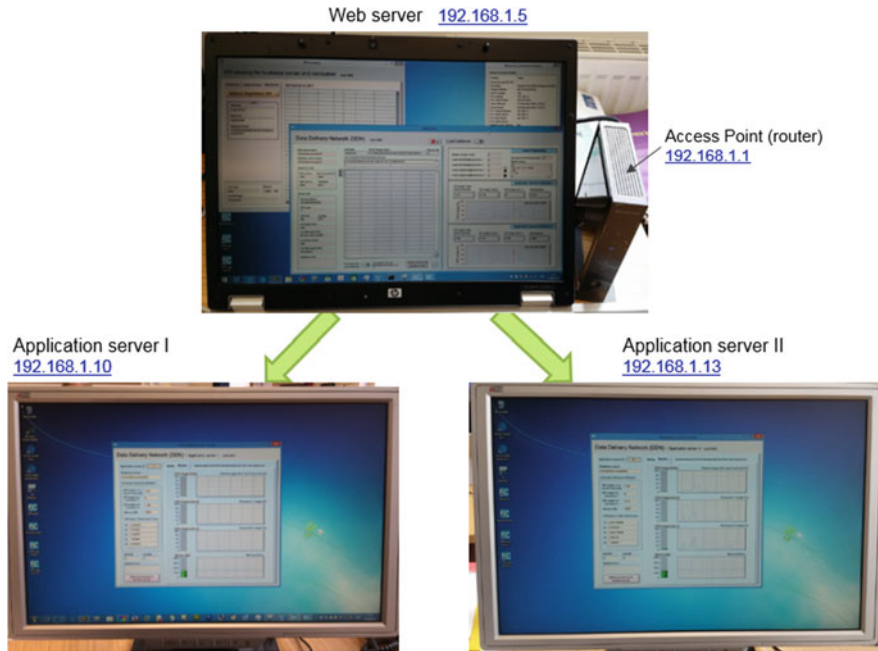

**Fig. 6.3** Communication across the three server computers formed by a Web server and two application servers

change of the data of software within the servers located at the nodes. For instance, one of the application server (e.g. “Application server I” shown in Fig. 6.3) updates the data from a specific software, which will immediately inform the Web server of this change by synchronising the updated data to the Web server. By this means, the application server’s computer hardware information (CPU, memory usage, etc.) is real-time transmitted to the Web server. Then the resource usage of two application servers are compared according to their hardware information, and the Web server will select the lower usage application server to distribute tasks.

Figure 6.3 shows the communication process across the three servers. In this example, the Web server receives the following two requests from a company client (an operation model located in the supply chain):

- (1) The client sends the ID information to the Web server for the verification, in order to build a connection from the Web server to the client;
- (2) The client transmits data required for the eco-point calculation to the Web server.

Firstly, the Web server distributes the above two requests/tasks to the two application servers respectively. For the first request, the Application server I (the first application server) receives the request of verifying the company client’s identity. With matching the user data with the database, the ID information verification is

completed and the connection between the Web server and the company client is successfully established. As a return, the company client user is allowed to log in the system. For the second request, the Application server II (the second application server) deals with the request assigned to add the new data to the database, which is shown in Fig. 6.3. Subsequently, the databases of two application servers are synchronised via a data mapping means, which ensures that the new data is also transmitted to another application server (i.e. Application servers I).

The result shows that both application servers can work in parallel to deal with a large number of data processing requests/tasks simultaneously. In actual tests, the overall usage of CPU of application servers remains within the range from twenty percent to seventy percent, subject to the amount of computing tasks and the hardware performance of each application server. The application of multiple application servers effectively balances the workload of tasks, and hence, optimises the information flow transmitted through the system. When one application server works at high resource usage, the other application server takes over other tasks in time. The scalability capacity is essential to improve the system's overall performance. This system is able to scale up to add new server computers, by installing the same operation system and application software and allocating the relevant communication address and ports of the new computers, which will enhance the capacity of dealing with data.

In summary, the operation of a distributed computing system is described in the following steps:

- Step 1: A client, such as a company or a consumer, initialises a request with the Web server, for example, a company transmits new dynamic data to the Web server for the further calculation of eco-point.
- Step 2: The Web server monitors the computer resource usage of the two application servers, which are accomplished by running a central controller for managing all the network nodes, for example, by using the network-published node engine.
- Step 3: Based on the usage of application servers, the Web server allocates the requests/tasks to the optimal performance application server, such as the application server with the lower computer usage.
- Step 4: The application server resolves the requests and then interacts with the database server to perform data querying. The following requests can be performed: (a) new data for eco-point calculation are saved into the database; (b) the required data are fetched from the database and transmitted to the company or consumer client via the Web server

## 6.2 Web-Based Services Used in the Eco-Accounting Infrastructure

There are several Web-based services provided by the eco-accounting infrastructure, such as company and consumer registration service, software interface service, software download service, etc. Those services provide different functions to ensure that the dynamic data for eco-point calculation are transmitted between companies along the value chain; and that the eco-debit/eco-credit data generated on the eco-point are delivered to consumers (*for more information about eco-point, eco-debit and eco-credit please see Sect. 5.1 of Chap. 5*). The consumer's eco-account is built to record the eco-debits and eco-credits which the consumer gets by purchasing and recycling products. The major Web-based services are detailed in the following sub-sections.

### 6.2.1 Software Interface Service

Web-based software interface provides a means by which the Web server and the company/client (client side) can communicate each other via the related interfaces. The server that works on the network, typically the World Wide Web, is called the Web server. Generally, the Web server utilises a set of common application programming interfaces (APIs) enabling the company/consumer to connect with the server over the Internet.

One of the APIs popularly used for Web communication is Representational State Transfer (REST). In the RESTful architecture, a REST-enabled Web server provides access to resources, and the client side accesses and presents the resources. The above mentioned resource is identified by Uniform Resource Identifier (URI), which is a global identity for identifying the resource over a network. REST uses various representation tools to represent a resource, such as Extensible Mark-up Language (XML), JavaScript Object Notation (JSON) and text information. For instance, a client side (a company user or a consumer) invokes the interfacing method exposed as a REST, and then the REST messages based on XML grammar is created immediately and transmitted to the Web server. In a response to the client, the Web server returns a REST message that includes the querying results, such as product's eco-debits/credits values requested by the client side.

The server and client applications are allowed to be programmed and compiled in different computer programming languages, such as C, Java and Python. It means that the REST-enabled applications supports a wide range of multi-language environments, and thereby, they can run at any desktop and smartphone systems, including Windows, Mac, Linux, Android, etc.

The Hypertext Transfer Protocol (HTTP) is the primary protocol for the REST method, which makes the service's request and response transmission over a very well-known transport protocol. The following HTTP methods are most commonly used in a REST based method:

- GET: provide a read-only access to a resource.
- PUT: create a new resource.
- DELETE: remove a resource.
- POST: update an existing resource or create a new resource.

The REST method can work with many digital encryption technologies, such as Secure Socket Layer (SSL) and Transport Layer Security (TLS), in order to create the secure and encrypted connections between the server and the client (for more information about the data encryption technology please see Sect. 6.4).

Figure 6.4 shows the work flow of the Web-based software interface service, which allows a company client to deliver the product’s eco-point values to the Web server and also the Web server to transfer the eco-debit data to a consumer client based on the REST interfaces. The above process is detailed as follows:

(1) Transmission of eco-point value from a company to the Web server

A company (client) initialises a remote connection to the Web server via submitting a ‘Send Eco-point Data’ request, via calling the REST interface exposed by the Web server. Then the Web server passes such a request to the application server, which includes (a) the eco-point values to be transmitted to consumers in supply chain; and (b) an identity of a session (also called session ID), which allows the company to transmit the eco-points to the Web server using a common connection session. The application server executes the request and stores the eco-points in the correct location

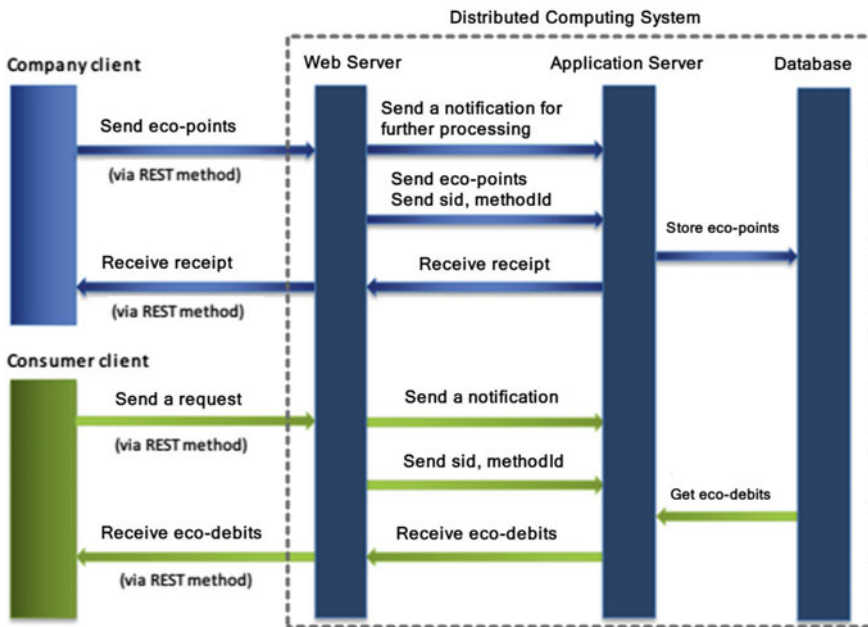

Fig. 6.4 Web-based REST interface services for transferring eco-point and eco-debit values

within the database via using the Open Database Connectivity (ODBC) system. The ODBC provides database interfaces which allow the server application to access the database and regulate the data records within the database. After completion of the request, the Web server sends a XML message ‘Success’ via the REST interface to the company client, in order to confirm the successful completion of the request.

(2) Transmission of eco-debit value from the Web server to a consumer

To obtain the eco-debit values from the Web server, a consumer client establishes the connection to the Web server via submitting a ‘Receive Eco-debit Data’ request with the REST interface for consumer client. Then the Web server creates a session with consumer identity, and sends the request to the application server for further processing. The application server analyses the request, fetches the required eco-debit values from the database via the ODBC interface, and then returns the data to the Web server. In response to the consumer client, the Web server compiles the data in a specific Web manner (e.g. XML) and transfers the data to the consumer client via the REST interface.

## 6.2.2 User Registration Service

The user registration service is used to manage the information within the consumer eco-account. The user registered is authorised to sign in the eco-account, in order to further view the eco-debit values obtained via purchasing the products and the eco-credit data rewarded via recycling activities (*for more information about eco-debits and eco-credit please see Sect. 5.1(1) and 5.1(2)*). Taking into account of user privacy, the service consist of the following four parts:

(a) User registration

This function allows the consumer to create as a new user. A user ID will be created as a unique identifier of this user in the system at the time of the registration. If the registration is requested by a consumer, a consumer ID will be generated, which will form the basis of the unique identifier of user card (e.g. a RFID or a NFC card) made for the consumer.

(b) User authentication

A consumer user provides the confidential to validate the user ID and ensure that only registered user utilises this system for the further communication. A communication process between the Web server and company/consumer consists of several sessions (Zhang 2012). Within a specific session, an ID for this session will be created as a unique identifier for further interaction with the Web server (for more details of the session ID please see the following sub-section ‘Session identity’).

(c) Verification of the user operation time

This function allows a consumer user to verify whether the session ID is valid. Each session can only be used within a limited time period, such as ten minutes. If a user does not work on the system after this time limit, the session will be expired and terminated automatically to guarantee the security of user information data.

(d) Delete a user

To execute this operation, a consumer user is required to enter the necessary confidential information in order to confirm this operation.

As stated in the above (b), the user is required to submit the username and password to the Web server for validation, in order to sign in the system. Once the user identity is verified, the server will create a session and assign a unique ID for the session, which will be used for the interaction with the Web server. The functionality and security of the session ID are presented as follows:

- Session identity

In the communication between the Web server and the consumer client, several sessions are created by the Web server and are linked to the company/consumer. Within this communication process, each session generates a unique ID, or called session ID, which is vital to keep track of the communication between the company/consumer and Web server, including the personal information, input request, and submission of each user (Zhang 2012). The session ID indicates that an interaction session is established successfully. Then the company/consumer holds the session ID, e.g. uses it as a parameter in 'Sending Data' or 'Receiving Data' interface method, and continues to interact with the Web server.

The session ID (or session token) is a piece of data that is used in network communications to identify a session with a series of related message exchanges. The advantage of using session ID is that the client only needs to handle the identifier (a small piece of data which is otherwise meaningless and thus presents no security risk). All session data are stored on the server, to which the consumer/company client does not have direct access. The session ID is typically short-lived, which expires after a present time of inactivity, such as five or ten minutes. Therefore, the session ID used in the eco-accounting environment is not valid after a certain request/task has been completed. In another word, once the task is finalised, the session ID will be deleted and the associated session will be terminated.

- Securing and encrypting a session identity with Hash

The session ID, as a unique identifier of a session, is usually existed in the form of a 'Hash' that is generated by a Hash function. The hash function is an encryption method, which maps digital data of arbitrary size to digital data of fixed size, with slight differences in input data by producing very big differences in output data (National Institute of Standards and Technology 2001). A typical hash function

**Fig. 6.5** A Hash function mapping user names to hash digits, which is used to conceal users' names to protect their privacy

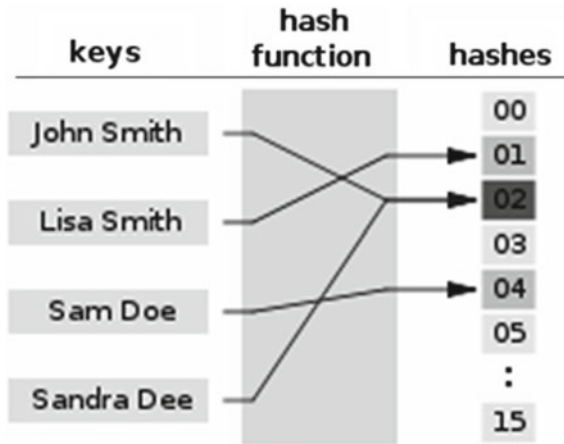

is related to checksums, check digits, fingerprints, randomisation functions, error-correcting codes, and ciphers. The values returned by a hash function are usually called hash values, hash codes, hash sums, or simply hashes.

A hash value can be expressed as a session ID. This requires that the value is 'collision resistant', which means it is impossible or very difficult to find data with the same hash value (Isard et al. 2007). Figure 6.5 is an example of hash function that maps names to integers from 0 to 15. There is a collision between the names "John Smith" and "Sandra Dee", which have the same hash value '02', and hence, they are not aligned with the condition of collision resistance.

The collision resistance can be accomplished by generating very large hash values. To do so, the hash function based on SHA-1 (Secure Hash Algorithm-1) is usually adopted. SHA-1 is one of the most widely used cryptographic hash functions, which may generate 160-bit large values and meet the requirement of collision resistance of session ID. Compared with the other cryptographic hash functions such as the Secure Hash Function, SHA-1 is more secure and faster when dealing with a large number of keys, such as user names of company and consumer clients.

### 6.2.3 Data Management Service

There are various types of data, such as dynamic data for eco-point calculation, eco-points, eco-credits and eco-impact values, and other information related to the products, which are possibly distributed at different locations within the eco-accounting environment. Those data are managed utilising the data management service based on the Open Database Connectivity (ODBC) system.

The ODBC provides the function to connect the database and manipulate the data/records within the database using a set of standard database interfaces. The database is a component associated with the ODBC. In terms of the type and functionality of data, the following two databases are constructed: the product information database and the user information database, which are detailed as follows:

- (1) The product information database is used to collect the information related to products, which includes serial number of products, product ID, description, recyclable components, and eco-points. The eco-point describes the impacts of products on the environment throughout the products' life-cycle, by which the eco-impact value and eco-credit are further developed.
- (2) The user database is used to manage the information of the customer's eco-account, which contains account number (personal identification code), account name, contact information, eco-impact values and eco-credits which consumers are obtained by taking part in purchasing and recycling activities (*for more information about eco-credit please see Sect. 6.1.1*).

To manage the data/records within the database, the ODBC provides the following interfaces for the connection to the database:

- 'Select query', to query/match the data received (e.g. serial number of the product or personal identification code of the customer) with the records in the database, in order to obtain the product information or customer details.
- 'Insert query', to add a piece of records in the database, e.g. adding new product's eco-point and eco-impact value in the product information database, or registering a new consumer eco-account in the user database.
- 'Update query', to update the data in the user database or product information database.
- 'Delete query', to delete a piece of records from the database, e.g. a product or a consumer's eco-account.

Figure 6.6 shows the graphic user interface for ODBC configuration, which allows for the connection to the database in the PostgreSQL data management system, based on the TCP (transmission control protocol) method.

A meta-database structure is necessary for managing the data within the databases in an effective way. This includes common meta-data search, data modelling, creating descriptive metadata to facilitate discovery of relevant information with particular emphasis on organizing electronic resources, facilitating interoperability and legacy resource integration based on the established standards and interfaces, providing digital identification, supporting archiving and preservation, and development of SOA (Service Oriented Architecture) services access to the meta-data search structures and SOA-based results presentation and management (Thatte 2010).



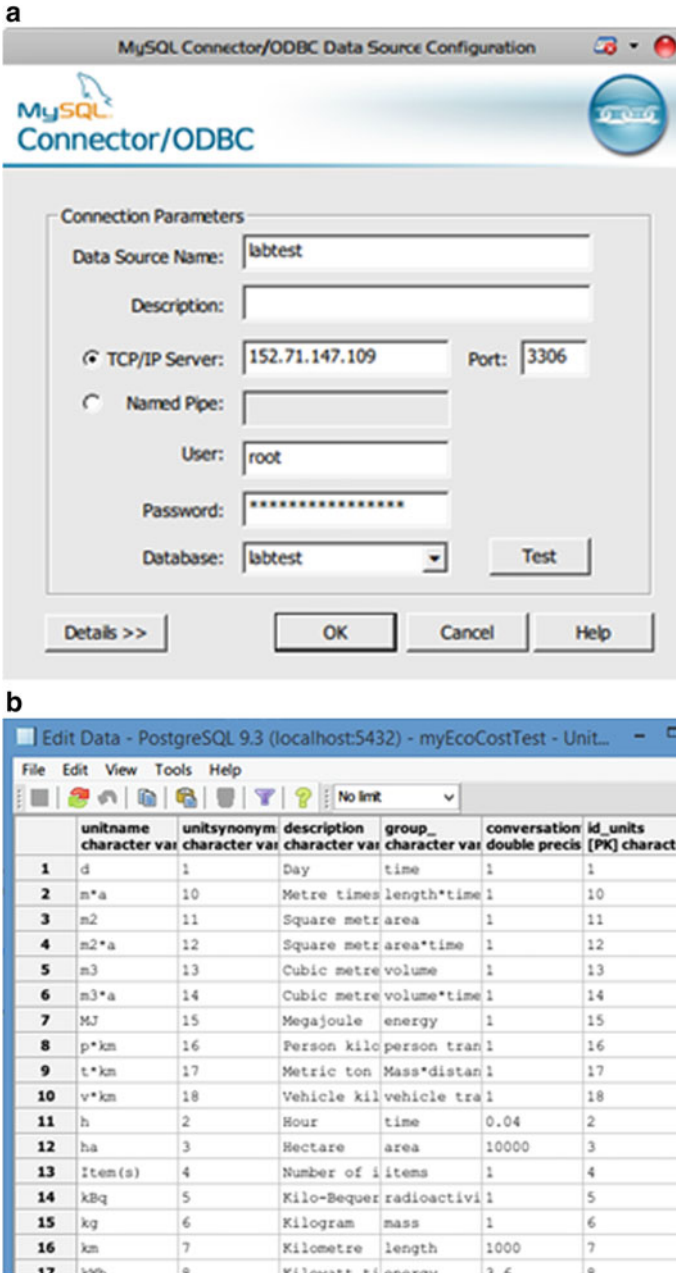

Fig. 6.6 a Database connection with ODBC. b PostgreSQL data management system

### 6.3 Application of NFC, RFID and Mobile Communication Technologies in Eco-Accounting Infrastructure

NFC (near-field communication) is a set of standards for smartphones to establish the communication between smartphones and NFC media by touching them together or bringing them into close proximity (Ghiron et al. 2009); and RFID (Radio Frequency Identification) is the wireless non-contact use of radio-frequency electromagnetic fields to transfer data, for the purposes of automatically identifying or tracking tags attached to products (Zhang 2012).

Nowadays, NFC/RFID have been widely used due to its powerful data storage advantage compared to similar product identification technologies, such as barcode. By combining with mobile techniques, NFC/RFID can be applied to the following aspects: (i) in the store, a consumer utilises the smartphone to scan the RFID tag embedded in the product to view the eco-points of the product. By comparison of different product's eco-points, the consumer selects more sustainable products. (ii) When the consumer buys the products at the check-out point, the products' eco-debits generated by purchasing are recorded in the consumer's eco-account. (iii) When the consumer's electronic products come to the end-of-life, they recycle their products by scanning the RFID tags embedded in the products and then get the eco-credits, which could be used for paying new products, in order to promote the recycling of consumers. (iv) Both eco-debits and eco-credits are recorded in the consumer eco-account, which are further analysed to generate the eco-balance, which enables the consumer to view the daily impact footprints, as shown in Sect. 5.1(3) of Chap. 5. (v) To enable paying the products or recycling their electronic products, consumers have to first verify their ID with a NFC-enabled smartphone, in order to perform consumer's 'Sign-in'.

To achieve the above goals, the following functions have been developed, which are further detailed in Sects. 6.3.1, 6.3.2 and 6.3.3 (Fig. 6.7).

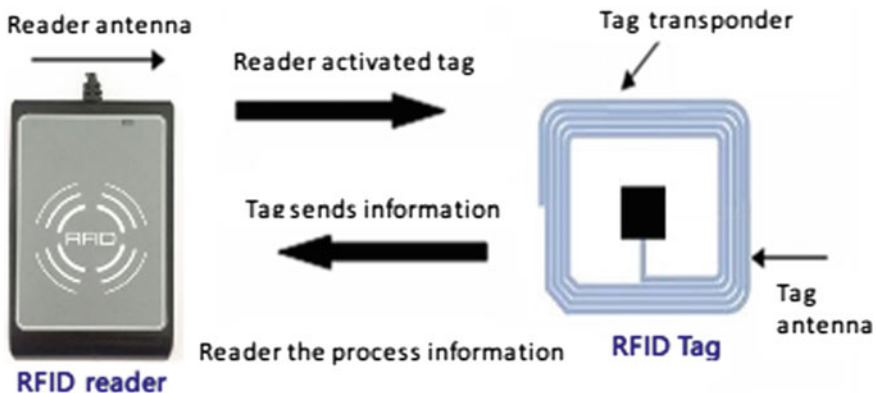

Fig. 6.7 Information transmission of RFID

- (1) Verify the customer's ID via scanning the embedded NFC chip of the smartphone;
- (2) Recycle customer's end-of-life electronic product via scanning the RFID tag embedded in the electronic product;
- (3) View the eco-points of the product which is located on the shop shelf via scanning the RFID tag of the product.

### 6.3.1 NFC-Based Customer ID Verification

The NFC technology is used to validate the customers' identity and to allow the authorised customers to access their individual accounts in the system, as shown in Fig. 6.8. The customer's identity is represented by the personal identification code, which is a set of encrypted digital numbers related to the serial-number of a NFC-enabled mobile phone (smartphone). The personal identification code is written to the chip of the smartphone, which is used for the authentication of customer who signs in the user account.

The mobile App enabling the NFC technology is developed to transmit the personal identification code from a NFC-enabled smartphone (e.g. Android smartphone) to a NFC reader. This mobile App is coded using the Android software development kit (SDK), which allows the Android smartphone to interact with the NFC reader in the peer-to-peer (P2P) mode. Based on the P2P mode, the data are transmitted via the NFC Data Exchange Format (NDEF) messages (Broll 2007). The following code shows an example of how to create a NDEF message for the interaction between Android smartphone and NFC reader:

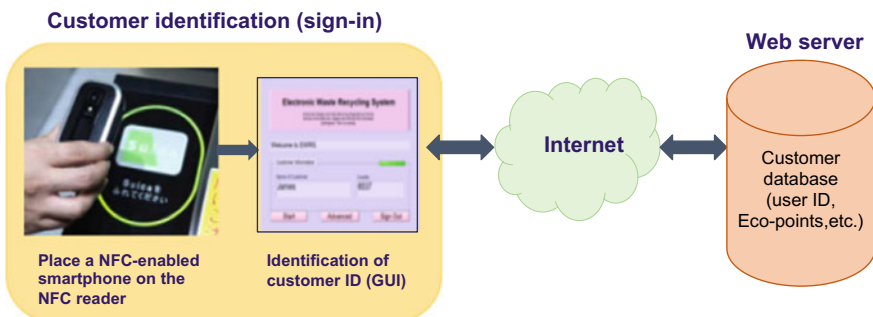

**Fig. 6.8** Enabling customers to sign in their user accounts with NFC-enabled smartphones

**Code #1:** create the use permissions for publishing/creating a new mobile app in Android store.

```
<uses-permission android:name =“android.permission.NFC”/>
<uses-feature android:name = “android.hardware.nfc” android:required
=““true”/>
```

In the above code, the item ‘Uses-Permission’ is used to set up the permission in order to publish the app in the Android market, such as the Android App store, while the item ‘Uses-Feature’ describes the app with the use feature specified.

Then the customer data, i.e. personal identification code, is encoded to the NDEF message using the ISO-Dep method, which is shown as follows:

**Code #2:** encode the customer data to the NDEF message for the RFID reader to read.

```
Tag tag = (Tag) intent.getParcelableExtra(NfcAdapter.EXTRA_TAG);
IsoDep isoDep = IsoDep.get(tag);
byte[] data = {0x01,0x02,0x03,0x04,0x5};
isoDep.connect();
byte[] rdata = isoDep.transceive(data);
isoDep.close();
```

The NFC reader retrieves the NDEF messages with the customer data from the Android smartphone, and then delivers it to a processing device, such as front-end computer. This requires that the NDEF messages are dealt with by calling the Libnfc.dll, which is a ‘dynamic link library’ file for resolving NDEF. When the NDEF messages is parsed, the personal identification code is obtained (Peng and Su 2015).

The personal identification code has to be sent to the Web server for verifying the trueness of the customer information. Subsequently, the personal identification code is transmitted to the Web server. The verification of the code is conducted by matching it with the records within the customer user database (for the details of the customer user database, please see Sect. 6.3.3). If the verification is successful, then the customer information, including customer’s account ID, account name and points, will be returned, which indicates that the customer is authorised to utilise the system, for example, to proceed recycling their electronic products, and viewing the sustainable information of products.

### 6.3.2 RFID-Based Recycling of Customer Electronic Products

When the consumers' electronic products come to the end-of-life, they can recycle their products. Recycling of electronic products is implemented based on RFID technology (for the information about the overview of recycling consumer electronic products please see Sect. 5.2(2) of Chap. 5). To do so, the electronic product's serial number is converted to a RFID code with ruggedness and reusability, which is then implanted in the RFID tag of electronic product. This above-mentioned serial number is used as the unique identifier to identify the product, which links to the products information. Figure 6.9 shows a RFID tag/label embedded in the electronic product, which has a unique product serial-number.

When a customer places an electronic product on a RFID reader, the product serial-number is retrieved by the reader from the RFID tag of the electronic product (see Fig. 6.10), which is then sent to the Web server for accessing the product sus-

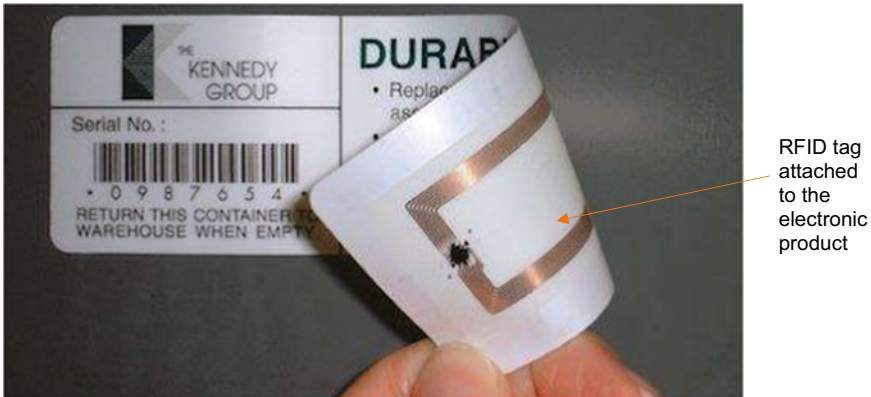

Fig. 6.9 RFID tag attached to the product

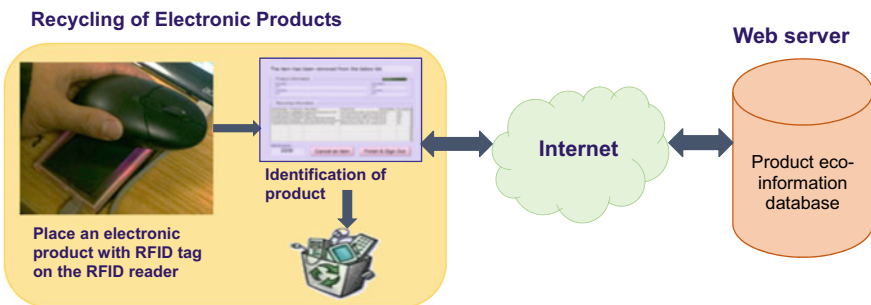

Fig. 6.10 Recycling of consumer's electronic products with RFID technology

tainable information. The product sustainable information obtained includes product ID (serial number), product description, and the information regarding the product's environmental impact, such as recyclable content and eco-points. The eco-point is a composite measure of the overall environmental impact of a product, which is used to assess the environmental impact of the electronic products throughout their life-cycle (Bare et al. 2013). Then the eco-debit is calculated based on the eco-point and recorded in the consumer account.

To achieve the above function, a RFID interfacing programme is developed, which enables the RFID reader to access the serial-number from the RFID tag. In this research, the RFID tag utilises the ISO 14443 Type A/B standard (Thatte 2010), which can be recognised by the RFID reader programmatically.

During the development of the RFID interfacing programme, the Microsoft Smart Card application programming interface (API), as a programming tool of interface of smart cards, is utilised for the RFID reader to communicate with RFID tag. The Microsoft Smart Card API, an open-source RFID application programming interface, contains a number of functions by which the product's serial-number data can be transmitted from the RFID tag to the RFID reader.

The major programming functions for RFID interface development include: "SCardEstablishContext", "SCardListReaders", "SCardGetStatusChange", "SCardConnect", "SCardTransmit", and "SCardDisconnect", which are utilised to develop the programme in the following steps:

- (1) Establish a RFID communication environment with the "SCardEstablishContext" function.
- (2) Search all the RFID readers installed on the system with the function "SCardListReaders".
- (3) Power on and activate a reader which waits for a RFID tag to connect.
- (4) Once a tag is detected, the function "SCardGetStatusChange" returns the detection status value to the computer.
- (5) Make a connection from the reader to the tag with the function "SCardConnect".
- (6) Transmit a coded serial-number data to the computer via the reader with the "SCardTransmit" function.
- (7) Close the connection between the reader and the tag with the "SCardDisconnect" function.
- (8) The gained data are decoded to the serial number of electronic products, which are then passed on to the Web server in order to obtain the product eco-information, such as eco-costs.

The RFID system has been successfully developed for monitoring the recycling process of electronic products in the research environment of the Advanced Design and Manufacturing Engineering Centre (ADMEC). The RFID-based data communication capacity is verified by transmitting product information from the Web server to a RFID monitoring computer. Within this case, an electronic mouse with the embedded RFID tag is utilised as the end-of-life electronic product to demonstrate the recycling process, while a Google Nextus Android smartphone is used as a client side, i.e. a consumer, to get the permission of signing in the system.

Figure 6.11 shows that a customer signs in with the Google smartphone and the relevant sign-in information is displayed within the graphic user interface (GUI) on the monitoring computer. When the customer places the Google smartphone on the NFC reader, the verification is conducted via connecting the Web server remotely. The Web server verifies the customer's personal identity code using the customer information records within the user database. When the customer's identity is verified successfully, the log-in indicator turns to be green, as shown in Fig. 6.11a; and then the customer's name and eco-credits obtained via the recycling activities are displayed on the user interface of the monitoring computer, as shown in Fig. 6.11b.

When the customer's identify is verified, they can recycle their electronic products. Figure 6.12 shows the recycling of electronic products via accessing the serial number from the RFID tag embedded in the mouse. First, the customer scans the electronic mouse with the RFID reader. Then, the serial number of mouse is gained and sent to the Web server for identifying the product's information and retrieving its eco-point data.

Based on the eco-point obtained, the eco-credit is calculated using Eq. (5.1) presented in Sect. 5.1(2). When the customer ends up scanning all the electronic mice, total eco-credits are obtained, which were then recorded into the customer account. Those eco-credits are accumulated with the existing eco-credits which are rewarded to the customer before. Figure 6.13 shows the eco-credits which the consumer obtains via recycling electronic products, which are then recorded in the consumer eco-account.

The eco-credits obtained could be used for purchasing the products. In the store, the consumer logs in the system using their smartphone; and then they scan the serial numbers of products which they intend to purchase via a RFID reader located at the self-service payment point. The serial numbers of products are sent to the data processing centre for calculating the eco-credits needed for payment. While scanning all the products, the consumer makes the payment with the eco-credits, which are then taken away from the customer's eco-account. If the eco-credits are not enough, the payment will either be advised to pay via cash, or be cancelled.

### ***6.3.3 Eco-Shopping with Mobile Communication Technology***

When consumers make purchase in local stores or e-stores, they are allowed to view the sustainable information of products, such as eco-points and sustainable production information during the product life cycle, via scanning the RFID tag embedded in the product, in order to facilitate consumers to select sustainable products. In detail, the products are displayed on the shelves in a store, which contain RFID tags with products' sustainable information. Consumers scan the RFID tag of the product using mobile phone to obtain the product sustainable information (see Fig. 6.14). Alternatively, they can utilise the specific computer tool to get the related product information from the e-stores or company Websites. The information of different

**a**

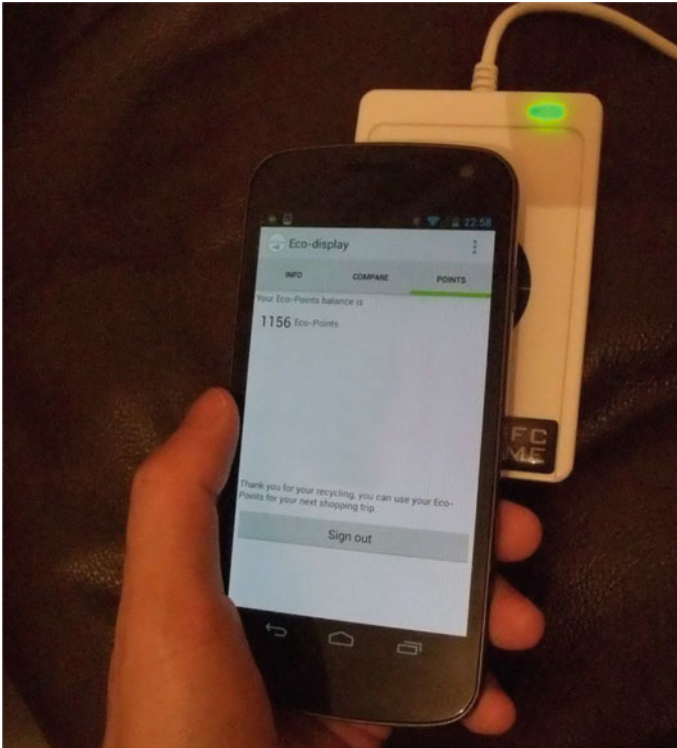

**b**



**Fig. 6.11** **a** Customer signs in the system with NFC-enabled Google Nextus smartphone. **b** The customer's sign-in information showing the eco-credits received



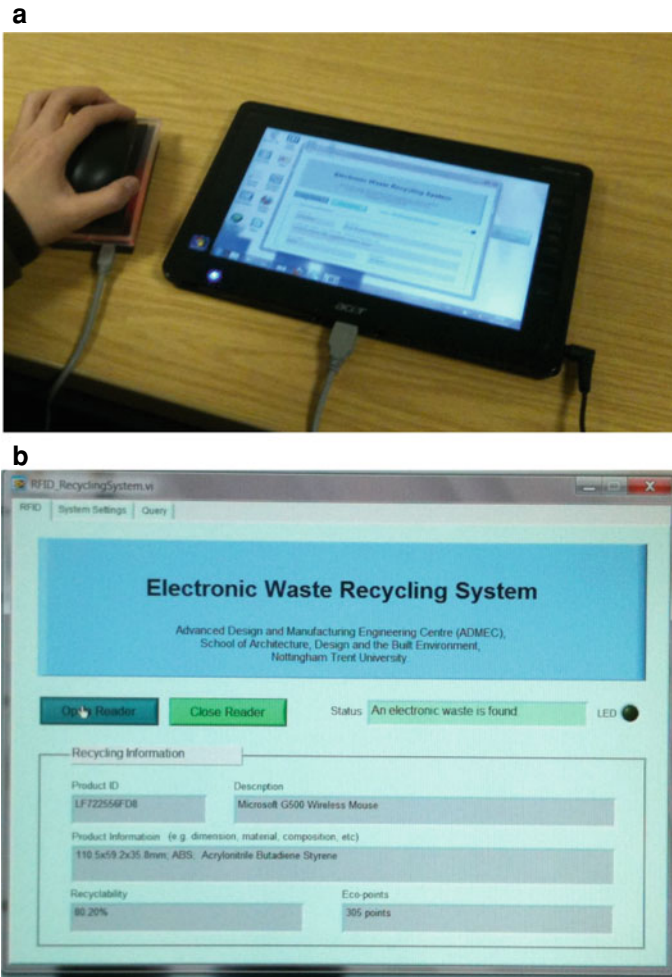

**Fig. 6.12** a Recycling of an electronic mouse with an embedded RFID tag. b The information of the recycled product displayed on the monitoring computer

products are comparable, allowing consumers to seek more suitable products and, in the meantime, help them make decisions for purchasing.

During the eco-shopping system development, the following work are conducted:

- (1) Integration of product eco-information into the RFID tags.

The necessary RFID development method, which is presented in Sect. 6.3.2, is utilised to integrate the product sustainable information into the RFID tag, i.e. to encode/program the information data to the micro-chip of RFID tag. The current popular method is that the RFID tag records the product ID only, which links to the product sustainable information located in an online database. When the product

<b>DataRead_UserID</b> 74201249915613640	<b>DataRead_WasteSN</b> 421799216212329132
<b>Username</b> James	<b>Product ID (PID)</b> P6987654DF
<b>UserAddress</b> xx Mansfield Road, Nottingham	<b>Description</b> Apple iPad
<b>Eco-Credit</b> 741	<b>ProductInfo</b> 241.2x185.7x9.4mm;
	<b>Recyclability</b> 84.1%

Fig. 6.13 The eco-credits obtained are recorded in the consumer’s eco-account



Fig. 6.14 Consumer acquire the product’s eco-points via scanning the RFID tag embedded in the product with smartphone, which helps consumer to seek sustainable products

sustainable information is integrated into the RFID tag, the information will be able to be acquired directly, regardless of whether the Internet is available. The product sustainable information consists of the eco-point values and sustainable production information.

- (2) Mobile phone App for viewing the sustainable information of products in the shop.

To enable consumers to view the product sustainable information via mobile phones, the App for mobile phones is essential, which involves the setup of graphic user interface (GUI) enabling consumers to work on mobile phone, means to access the RFID tag, and treatment of information data (e.g. display and storage of data). The necessary database for storing the information data in the mobile phone must be constructed, which will closely works with the mobile phone App to capture and record the product sustainable information using the RFID tags on the store shelves.

- (3) Computer tool for viewing the sustainable information of products over the Internet

For the consumers who do not intend to go to shops, they can consider to utilise the specific computer tool for the e-stores to get the product sustainable information. The development of the tool includes the design of Web-based graphic user interface, methods for the access to the RFID tag, and processing of product information data. The relevant databases should be provided to store the information data, by which consumers view different products in the consumer's computer.

- (4) Interfaces to mobile phone App and computer tool

The necessary interfaces are utilised for mobile phone App or computer tool to access the eco-information located in the eco-information inventory/database. For the mobile phone App, the interface works to get product ID via the RFID tag, and then establish the connection from the mobile phone App to the eco-information inventory using the product ID obtained; for the computer tool, the relevant interface is used to create the connection from the tool to the product information database over the Internet.

## 6.4 Data Security

This eco-accounting infrastructure integrates several “open-source” services, such as software interface service and user registration service (for more details of the user registration service, please see Sect. 6.2.2), which facilitate the data processing/transmission between companies and consumers, and hence, involve data security and privacy issues. This issue can be addressed by:

- (1) Creating a secure user account management mechanism with privacy protection, to manage the information within companies' and consumers' accounts over the value chain; and
- (2) Utilising effective encryption technologies such as the Secure Sockets Layer (SSL), to protect the data of companies and consumers, when the data are transmitted through the 'open' platform.

The issue (1) is addressed by applying the Hash method to encrypt and protect the information within the user accounts, which has been presented in the Sect. 6.3.2; and the issue (2) is addressed using the SSL method, which is detailed as follows:

Within the eco-accounting infrastructure, a large number of data are to be collected and transmitted over the Internet, including eco-points, eco-debits, eco-credits, and relevant dynamic data. Those data could be hacked or tampered when they are transmitted without any protection measure. To secure the data, a digital encryption technology, called Secure Sockets Layer, is required.

The Secure Sockets Layer (SSL) is applied to protect the confidential details of companies and consumers via creating encrypted connections between the Web server (server side) and companies/consumers (client side) when their information is transmitted each other (OpenSSL 2018). The SSL ensures the security of data transmitted throughout the network, such as Internet, Intranet, and all the other server-based system/applications. Without the SSL, the integrity of data transmitted is not guaranteed because every link cannot be controlled in the transmission chains. During the data transmission, all the data wrapped by the SSL are encrypted and not tampered and leaked from the Web server to the client (i.e. a company or a consumer), and therefore, the data and relevant information within the eco-accounting system are able to be protected.

When a company or a consumer, as a client side, enters their confidential information via the graphic user interface (GUI) in the SSL-enabled Web browser, they may check whether the Web browser has a “safety lock” symbol, as displayed on the URL address bar shown in Fig. 6.15, which ensures that their information is under the protection of SSL.

Almost all of the server operation system and Web browsers support the SSL technology. In order to implement a SSL-based protection, a digital certificate, which is signed by the certificate authority (CA), must be installed on the Web server which is used to receive the data from a company or consumer. In general, the data transmitted between the Web-based browser and the Web server are shown in form of plain code, from which hackers can intercept information and falsify new data. With a SSL-based digital certificate, the secure channel between Web-based browser and the Web server is established; in other words, all the data transmission between them are encrypted, which will effectively prevent from the behaviour of harming data security and data integrity through illegal hacking measures.

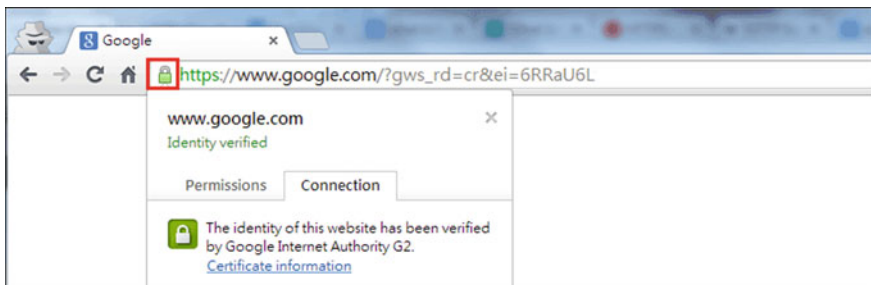

**Fig. 6.15** A Website using the SSL-based encryption technology shows a green ‘safety lock’ symbol at the address bar within the Google Chrome web browser

The SSL provides the authentication for both the Web server and the Web-based browser used by the company and consumer. When the Web server is installed a digital certificate issued/signed by the certificate authority (CA), it shows that the Web server is validated by the trusted third-party because this server's identity is authorised by the certificate; and then the company or consumer validates this certificate to confirm that the communication with the Web server is safe.

Installing a signed SSL certificate on the Web server may present its identity. Similar to the server side, every company and consumer should also have a SSL certificate installed at the client side. However, the installation of client certificates on every device of companies and consumers is not possible due to expensive installation costs. Therefore, it is recommended to adopt a means of identity verification, instead of the certificate. That is, the clients' ID status can be verified with a password management mechanism enabling client users to enter their username and password.

#### **6.4.1 Case Study: Development of SSL-Based Digital Certificate**

Within this case study, a standard digital certificate (i.e. X.509 certificate) is developed, in order to create a SSL-based secure connection between a Web server and a company client, and hence, to secure the data transmitted between the Web server and the company. A typical digital certificate contains the identifying information about the server, a public key and a digital signature. Server name, expiration date, and locale are examples of the identifying information. A public key is a string of characters used to generate the encryption, and the digital signature is a confirmation of the authenticity of the certificate. The digital signature is an important component, which can be added by the certificate creator who makes a self-signed certificate, or added by a certificate authority (CA), a trusted third-party company that issues digital certifications.

The SSL certificate files are developed with the OpenSSL software via the following procedures and operation commands:

- (1) Generation of a 1024 bit RSA private key, which is encrypted using Triple-DES cipher and stored in a PEM format that is as readable as ASCII text.

# operation command 1:

```
openssl genrsa -des3 -out server.key 1024
```

- (2) Generation of a Certificate Signing Request (CSR) from the private key. During the generation of the CSR, several pieces of information are prompted to enter the X.509 attributes of the certificate. One of the prompts is the "Common Name

(server FQDN or YOUR name)”, which can be provided by the computer name of the Web server, for example, the computer’s ping-able network domain name or the IP address.

# operation command 2:

```
openssl req -new -key server.key -out server.csr
```

(3) Stripping the passphrase entered below out of the server key.

# operation command 3:

```
copy server.key server.key.org
```

```
openssl rsa -in server.key.org -out server.key
```

(4) Generating and self-signing the server certificate using the .csr and .key files generated previously. Within this example, the certificate will be valid for 365 days.

# operation command 4:

```
openssl x509 -req -days 365 -in server.csr -signkey server.key -out server.crt
```

(5) Generation of a trusted root certificate that is common to both server and client computers. This step only applies to the self-signed certificate. If the certificate is not self-signed, then this file will be supplied by the issuing Certificate Authority. For the self-signed certificate, this file is a duplicate of the server certificate:

# operation command 5:

```
copy server.crt root.crt
```

- (6) Installation of the files `server.crt`, `server.key` and `root.crt` into the specific folder that is relevant to certificate files on the Web server.

Figure 6.16 shows an example of using OpenSSL software to produce the self-signed SSL certificate. In addition to this, this certificate can also be produced by other software which supports the SSL security and encryption method, such as LabVIEW, a graphical programming software developed by National Instruments. Figure 6.17a shows the development of the self-signed SSL certificate utilising the LabVIEW's Web-based Configuration and Monitoring utility system.

When the SSL certificate for the server are created, those certificate files need to be configured on the Web server, in order to trigger the SSL protection. Figure 6.17b shows the information about the process for the Web server to enable the SSL protection. The certificate files must be placed in a correct location on the Web server. When the SSL certificates works properly, then the SSL-based secure connection is created; and all the data transmitted via this secure connection are automatically protected, such as the dynamic data collected from different locations.

## 6.5 Design of Software Architecture

The design of software architecture is essential to develop a high-quality software system. The major aspects taken into account during the design of the software architecture include the functions and specification of the internal components such as systems and platforms, regulation of interoperability between the components, the means to access the relevant resources such as the database, and the specification of the infrastructure interfaces to the external operation models.

Within the eco-accounting system, the software architecture consists of the following three tiers: upper-ware, middleware and resources. The upper-ware controls the middleware (distributed computing, Web-based communication services, data security and privacy, NFC/RFID and mobile access) and associated resources, and interacts with the operation models (companies and customers) which work in the supply chain. Figure 6.18 shows the overview of three-tier software structure used in the eco-accounting system.

As the top layer of the software architecture, the upper-ware is applied for the coordination and the management of the middleware and associated resources, and the communication with the operation models. The framework for developing the upper-ware includes controlling and coordinating mechanisms, plug-in and play facilities. The upper-ware manages the interfaces for the communication with the operation models, and regulates the resources (e.g. database, mobile facility and relevant resources) and the interaction with the components located in the middleware.

The middleware is the layer accounting for technologies and methods used in the software development, which includes the following functions: provision of Web-based interfaces and services for the real-time communication with the operation models, allocation of requests/tasks of companies and customers to multiple server

```
C:\windows\system32\cmd.exe
(c) 2013 Microsoft Corporation. All rights reserved.
C:\Users\Menjie>cd D:\Program Files\phpStudy\Apache2\bin
C:\Users\Menjie>d:
D:\Program Files\phpStudy\Apache2\bin>openssl genrsa -des3 -out server.key 1024
Loading 'screen' into random state - done
Generating RSA private key, 1024 bit long modulus
.....+++++
.....+++++
e is 65537 (0x10001)
Enter pass phrase for server.key:
Verifying - Enter pass phrase for server.key:

D:\Program Files\phpStudy\Apache2\bin>openssl req -new -key server.key -out server.csr
Enter pass phrase for server.key:
Loading 'screen' into random state - done
You are about to be asked to enter information that will be incorporated
into your certificate request.
What you are about to enter is what is called a Distinguished Name or a DN.
There are quite a few fields but you can leave some blank
For some fields there will be a default value,
If you enter '.', the field will be left blank.
```

Generate a 1024-bit private key.

Generate a Certificate Signing Request (CSR) from the private key.

(a)

```
Country Name (2 letter code) [AU]:GB
State or Province Name (full name) [Some-State]:Nottingham
Locality Name (eg, city) []:Nottingham
Organization Name (eg, company) [Internet Widgits Pty Ltd]:Nottingham Trent University
Organizational Unit Name (eg, section) []:NTU
Common Name (e.g. server FQDN or YOUR name) []:127.0.0.1:9000
Email Address []:wenjie.peng@ntu.ac.uk

Please enter the following 'extra' attributes
to be sent with your certificate request
A challenge password []:
An optional company name []:

D:\Program Files\phpStudy\Apache2\bin>copy server.key server.key.org
1 file(s) copied.

D:\Program Files\phpStudy\Apache2\bin>openssl rsa -in server.key.org -out server.key
Enter pass phrase for server.key.org:
writing RSA key

D:\Program Files\phpStudy\Apache2\bin>openssl x509 -req -days 365 -in server.csr -signkey server.key -out server.crt
Loading 'screen' into random state - done
Signature ok
subject=C=GB/ST=Nottingham/L=Nottingham/O=Nottingham Trent University/OU=NTU/CN=127.0.0.1:9000/emailAddress=wenjie.peng@ntu.ac.uk
Getting Private key

D:\Program Files\phpStudy\Apache2\bin>copy server.crt root.crt
1 file(s) copied.

D:\Program Files\phpStudy\Apache2\bin>
```

Enter the organisation creating this certificate

Remove passphrase out of the server.key.

Generate a self-signed certificate

Generate a root certificate.

(b)

Fig. 6.16 Creating a SSL certificate with the OpenSSL software





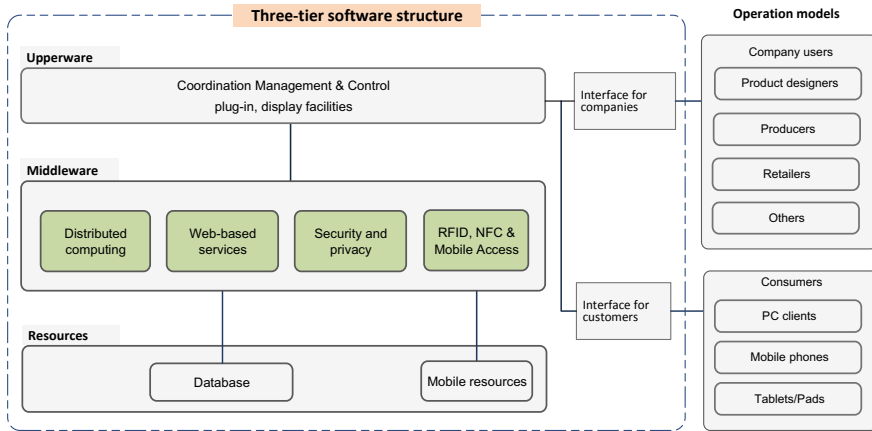

**Fig. 6.18** Overview of the software architecture for the eco-accounting system

computers, protection of the flow of eco-cost data, mobile access based on RFID and NFC for consumers to access eco-cost data, and the management of information located at the resource layer.

The necessary interfaces and integration for the software system includes:

- (1) Interfaces with the middleware. The interfaces enables the middleware elements to be connected to the upper-ware. A number of interfaces for distributed computing, Web-based communication services, data security and privacy, and resource management facilities are developed and adapted. To ensure that the developed interfaces are compatible with the upper-ware, the necessary graphic user interfaces (GUIs) are developed, which allows users to configure the components within the system and manage the inter-operation between the components.
- (2) The interface for integration of operation models. Because the operation models vary in the format and forms of their input and output data, as well as their functional requirements, the specifications of the interface for each operation model are constructed and interfaces are developed individually. The interfaces form part of the upper-ware of the software structure.
- (3) Integration of the middleware and related resources into the software architecture. With the interfaces mentioned in the above, distributed computing environment, Web communication services, digital security and privacy protection component, RFID, NFC and mobile facility, as well as the associated resources, are integrated into the software system.

## 6.6 Data Bridging Between a Stand-Alone Commercial LCA Software and Web-Based User Interfaces

With the increasing use of the Internet, the online LCA is becoming a trend in the product sustainability assessment. The online LCA provides functions for designers and manufacturers, who are dispersed geographically in different locations, to develop sustainable products via an online collaboration. Currently, some existing LCA software can be used to online assess the environmental impacts of products; however, they have the limitations in functions, use, and costs. For example, Sustainable Minds ([www.sustainableminds.com](http://www.sustainableminds.com)) offers simple online LCA function which is not suitable for the analysis of complex products; SimaPro ([www.simapro.co.uk](http://www.simapro.co.uk)) may be extended to perform online LCA via adding an add-on called 'COM', which is expensive and also difficult to use due to IT-related expertise required.

To overcome this problem, the Web-based user interfaces for commercial LCA software is developed, which can make the functions of the desktop-based LCA software (e.g. openLCA) available over the Internet, including LCI database import/export and modification, product lifecycle modelling, life cycle impact evaluation, and multiple analytical results presentation models, etc. Benefitted from the application of Web user interfaces, users are enabled to perform LCA of products with their smartphones via the relevant mobile communication interfaces (e.g. REST Web Service).

### 6.6.1 Overview of the Online LCA System

Figure 6.19 shows the overview of the Web-based real-time system for openLCA software, which consists of two parts: LCA server and client ends (i.e. PC or mobile phone). The LCA server controls four components, including High Performance Calculation Library (HPCL), Java Native Interfaces, Java Virtual Machine, and associated database, and interacts with client ends over the Internet. The Web-based openLCA, as a core of the Java virtual machine, is used for the assessment of product environmental impacts, such as online LCA calculation and incorporating users' customised LCA methods and related database. Within the Java Virtual Machine, the RESTful Web Service is applied for the openLCA components to connect with the client side, so that the functions of desktop openLCA software can be available on the Internet. The Java Native Interface (JNI) plays a role in bridging the openLCA and HPCL in order for improving the calculation speed.

The communication between the LCA server and the client end starts with the establishment of remote connection. Using the Web-based user interface, a client end (e.g. a PC or mobile phone) submits a connection request, which includes a calculation command, to the LCA server via invoking the REST Web Service. On the LCA server, openLCA analyses the request received and assigns the HPCL to

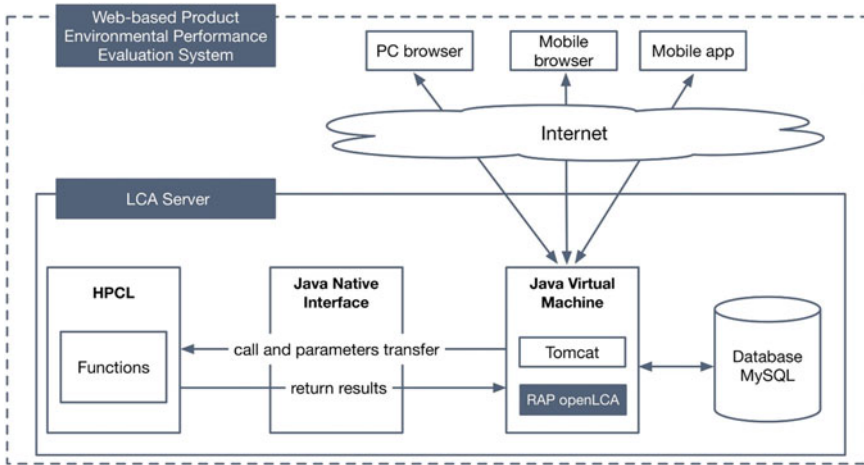

**Fig. 6.19** Overview of the online LCA system with a Web-based user interface

perform the calculation. To do so, the Dynamic Invocation Interface (DII) code of HPCL is triggered with the Java program within the Java Native Interface bridging the Java Virtual Machine and the HPCL, which achieves the high-speed calculation. The main interfaces invoked in openLCA are IMatrix, IMatrixFactory, and ISolver for solving linear algebra problems. Then the calculation results are transmitted back to the client side and stored in the database. The Web-based user interface developed client software/apps are applicable to different types of devices (e.g. PC and smartphone) and operating systems (e.g. Windows, Apple, Linux).

The development of the LCA server and the mobile phone client code are detailed in the following two Sects. 6.6.2 and 6.6.3.

### 6.6.2 Integration of OpenLCA Software with Web Technologies

Currently, openLCA (<http://www.openlca.org/>) is an Eclipse RCP-based software, which can only be applied in the ‘off-line’ desktop operating environment. To make openLCA as a Web-based server application, all the ‘off-line’ functions of openLCA have to be available over the Internet. To achieve this goal, the Eclipse Remote Application Platform (RAP) method is applied. This method allows for the Web-based user interfaces to be developed entirely in Java, and then to be included in a Web-based server application within the Eclipse development environment.

Figure 6.20 shows the structure of the RAP and RCP applications. The RAP application is suitable for solving issues related to multiple sessions, which is the main difference with RCP application. For example, with the RCP application, a

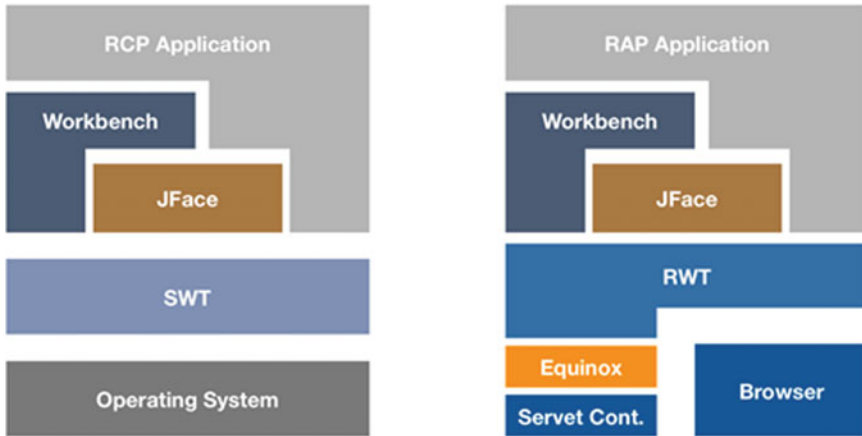

**Fig. 6.20** Differences between RAP and RCP applications

user can only get access to a single session (UI representation instance) from the code specified; however, the RAP application is based on a multi-user environment (i.e. multiple sessions at a time), i.e. there is only one application instance running, which is shared among different sessions. Further, the RAP method is suitable for developing Web-based applications and rich client applications from a single code basis. In particular, the existing RCP development code are reusable for Web-based RAP applications. In the process of transferring openLCA into a Web application, there are approximately 70–80% of the existing RCP code can be reused in the RAP code without changes.

Transferring openLCA into a Web server application involves the development of the RAP-based ‘custom widgets’ for openLCA. The custom widgets of openLCA are composed of the two parts that are interacted via the protocol: the server part that serves as a programming interface, and the client part that is responsible for the representation. The RAP version of openLCA can support direct access to the object on the server part via calling the Remote-Object function. With a specific internal interface that directly corresponds to the operations of the RAP protocol, the properties of the Remote-Object can be changed, methods can be invoked, and event notifications can be received. For example, the client part allows for a RESTful Web Service to be the interface, which contains the Remote-Object for the communication with the server part.

The developed RAP-based openLCA software has been packaged and then deployed on the LCA server of a computer with Intel i5 processor and 8 GB RAM. The operation environment is Ubuntu 14 with Tomcat 8.0 and MySQL 11.0. Since the existing Eclipse is not able to provide direct support for packaging a RAP application, a WAR-format file is utilised to package the developed files using several scripts and other resources. The packaged WAR file is then deployed in the Web Apps directory for the Tomcat installation. The calculation is online conducted using the RAP-based openLCA, with the aid of HPCL and Web Service. The Java Native

Interface is applied to deal with the tasks of dynamic data exchange and manage the interoperability between the RAP-based openLCA and HPCL.

### 6.6.3 Development of the Code for Mobile Phone

In order to interact with the openLCA software deployed on the LCA server, the necessary code for the mobile phone is developed utilising the JSON-based data exchange method.

Nowadays, the increasing trend for Web applications has fostered JavaScript Object Notation (JSON) as a popular data exchange format. JSON is based on a sub-set of the JavaScript programming language and can be parsed into JavaScript objects natively. In contrast to JSON, Extensible Markup Language (XML), another popular data interchange format, requires specific parsers for each XML-based language, which cause massive loads for Web applications. JSON consists of the two structures: an object that is a collection of key/value pairs, and an array that is an ordered list of values. The values in an object/array can be other objects/arrays, strings, numbers, Boolean and null values, because the objects and arrays map logically to standard JavaScript programming language structure. OpenLCA software allows for data parsing and calculation based on the JSON format, which supports communication with the consumer's mobile client.

Figure 6.21 shows an example of encoding the LCA data of a product in the form of JSON format. Within the mobile client, the calculation commands are processed

```
"@type": "ProductSystem",
"@id": "e673be33-b071-4ba2-9097-5b77a9c3ced2",
"name": "Ingot casting",
"description": "",
"version": "01.00.000",
"referenceProcess": {
  "@type": "Process",
  "@id": "55fd27b1-c73d-4a76-b560-cfc461e81efd",
  "name": "Ingot casting"
},
"referenceExchange": {
  "@type": "Exchange",
  "@id": "e4649009-ddb9-3c85-be99-1d635ffd3030"
},
"targetFlowProperty": {
  "@type": "FlowProperty",
  "@id": "93a60a56-a3c8-11da-a746-0800200b9a66",
  "name": "Mass"
},
},
```

**Fig. 6.21** An example of encoding LCA data of a product in the JSON format

**Table 6.1** Description of application programming interfaces for the openLCA software

Application programming interfaces (APIs) supported by the openLCA software	Descriptions
ImpactMethodExport	Export the EcoSpold file that describes the property of LCA methods
FlowPropertyExport	Export the all the flows involved in a product system
FlowExport	Invoke the product primary datasets selected
RefDataExport	Invoke the calculation results from server database
RefDataExport	Export the datasets reflecting properties of LCA calculation results, such as the unit of calculation result and the indicators of LCA methods

as user requests, by encoding them with the JSON rule for the communication with the RAP-based openLCA. Then the user requests with the calculation commands are sent to the RAP openLCA by calling REST Web Service, which immediately parses the received requests, performs the calculation, and subsequently transfers the calculation results to the client in the form of JSON.

The data calculation involved in the mobile client is performed by calling a set of application programming interfaces (APIs), which are supported by the openLCA software. The APIs offer the bridge of the interaction between the mobile phone and openLCA, enabling openLCA to receive and process the calculation commands requested by the mobile client, which are described in Table 6.1.

The above APIs are utilised to support the commands/requests from different operation systems, including desktop PC systems, mobile phone systems (e.g. Apple iOS, Android, and Windows Phone), and other enterprise-level systems.

#### **6.6.4 Case Study: Viewing the Product's Eco-Points via Web-Based User Interfaces of Mobile Phone**

The Web-based user interfaces for mobile phone have been successfully developed, enabling customers to access, view and compare different products' eco-impact values. This will facilitate customers to select the environmental friendly products, and further, to affect their sustainable consumption behaviours. The Web-based user interfaces for mobile phone are developed with the Apple iOS programming environment, which consists of the following four sections:

(1) *Customer register and log-in*

The 'Signup' user interface, which is shown in Fig. 6.22a, allows the customer to register the account when they first use the consumer client app. The customer is

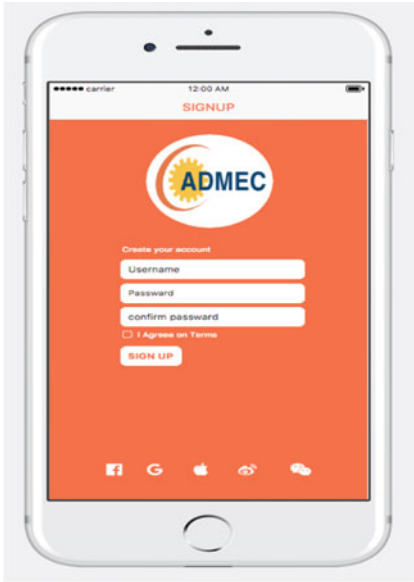

(a). Customer register and log-in



(b). Quick LCA calculation

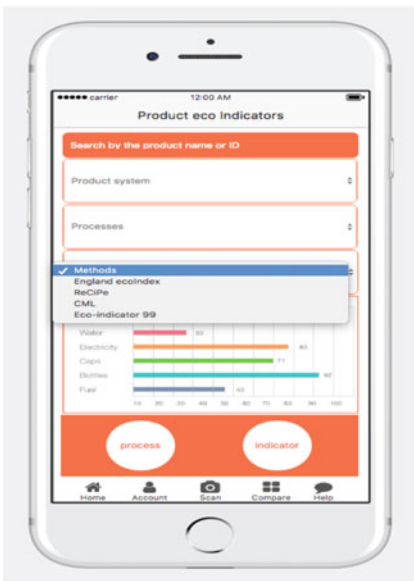

(c). Detailed LCA calculation, via defining the scope, process and method of evaluation.

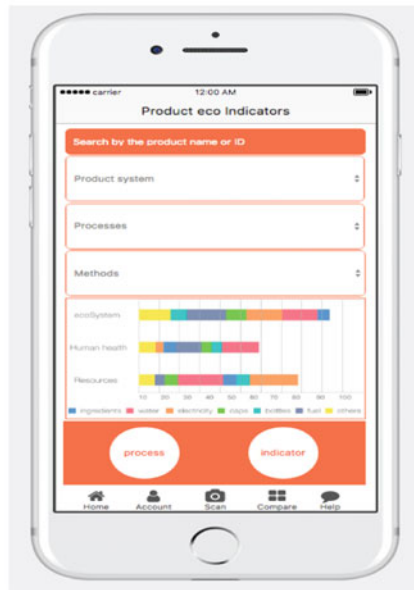

(d). Display of LCA results

Fig. 6.22 Development of Web-based user interfaces for mobile phone



allowed to log in the account and change the personal information, such as user name and password, and even delete all the data stored in the account belonged to this customer. Also, the customers can set up the preference of their accounts, such as the display of account information.

### (2) *Quick LCA calculation*

The customer can select a product by scrolling the drop-down menu of recorded products, in order to perform a quick environmental impact assessment of the product. ReCiPe, a commonly known LCA method, is selected for the impact assessment in advance. As Fig. 6.22b shows, when the customer selects a product, the picture of this product is shown on the top-left corner of the user interface, while the environmental impact indicators are shown next to the picture. Since ReCiPe is applied, the values of the three environmental impact indicators related to ReCiPe are calculated via connecting openLCA server, and then shown on the right of the picture, including ecosystem, human health, and resources. The product's eco-point is analysed based on the three environmental impact indicators, and then the eco-impact value is obtained. Subsequently, an intuitive curve diagram is shown for demonstrating the overall environmental impacts of the consumers' purchased products through one month.

### (3) *Detailed LCA calculation with consideration of evaluation scope, process and method*

The 'Calculation' user interface allows for the customer to conduct more detailed environmental impact assessment of the product. The customer can create a new Product System via determining the scope, process and method of the LCA calculation, which includes the following aspects respectively:

- Scope: cradle-to-grave, cradle-to-cradle, cradle-to-gate, and gate-to-gate through product's life cycle;
- Processes: raw material, production, packaging, transportation, consumption, and end-of-life;
- Methods: England ecoIndex, ReCiPe, CML, eco-indicator 99.

As Fig. 6.22c shows, the above three items are defined by the customer, and then the calculation task is online performed. The result is processed to be shown in a horizontal bar graph, with the consideration of the limited screen space of mobile phone. Within the result displaying window, the environmental impacts within every process of the selected product are analysed for identifying the root of pollution and emissions caused by the processes.

### (4) *Display of LCA results*

There are the two different methods showing the calculation results of process flow and the environmental impacts, which can be implemented by clicking the two buttons ('Process' button and 'Indicator' button) within the 'Calculation' user interface shown in Fig. 6.22d. When clicking on the 'Indicator' button, the names of three

end-point indicators (i.e. ecosystem, human health, and resources) are indicated on the Y-axis, while the values of the indicators assessed by the ReCiPe method selected are shown along the X-axis. When clicking on the 'Process' button, the processes or resource flows with negative environmental impacts are shown on the Y-axis, while the values obtained by the LCA calculation are shown along the X-axis.

## 6.7 Conclusion

This chapter presents the methods of dynamic data collection, processing and management, and related IC technologies for implementing the eco-accounting infrastructure (please see Fig. 5.2 in Chap. 5), which have the following important features:

- In the eco-accounting infrastructure, the three fundamental ICTs (distributed computing, Web-based services and security and privacy) ensure the acquisition and management of dynamic data. Distributed computing technology is applied to deal with real-time dynamic data that are collected from various operation models over the product supply chain, while multiple Web-based services allow the dynamic data to be transmitted from one operation model to another in order to ensure the product's eco-point calculation. Data security provides the protection for user data and privacy during their transmission through the products' life cycle.
- Data bridging for online LCA allows the users to develop sustainable products collaboratively, based on common Web-based user interfaces.
- The NFC, RFID and mobile communication technologies enable customer's ID verification, electronic product recycling, and eco-shopping.
- The necessary software structure is designed for the above ICT applications.

This research has made the following novel contributions to implement the eco-accounting infrastructure:

- (1) In the eco-accounting, there are large amounts of dynamic data required for the eco-point calculation. Those data are usually dispersed in different locations, which restrict data capture, and hence, affect the quality of eco-points resulted. This research develops a novel dynamic data management method, based on tracking and monitoring each stage at supply chain, which overcomes the problem of massive data acquisition throughout product's life cycle.
- (2) A number of ICT methods are integrated into the eco-accounting implementation, which has not been available in the literature so far, and hence, it is a novelty to develop and implement the eco-point approach (e.g. eco-shopping, online LCA, consumer eco-account, recycling/reuse, etc.) through applying multiple advanced information processing, communication and networking technologies.

**Acknowledgements** The authors acknowledge the European Commission's financial supports for the FP7 myEcoCost project (grant number 308530) which provided the basis to develop the ICT support for the eco-accounting infrastructure, and for the H2020 CIRC4Life project (grant agreement number 776503) for refinement and application of part of the ICT techniques presented in this chapter.

## References

- Bare, J. C., de Haer, Udo, & Pennington, D. W. (2003). Life cycle impact assessment sophistication. *International Journal, Life Cycle Access*, 4(5), 299–306.
- Broll, G., et al. (2007). Supporting mobile service usage through physical mobile interaction. In *Proceedings of PerCom 2007, White Plains*, IEEE Computer Society, pp. 262–271.
- Ghiron, S. L., et al. (2009). NFC ticketing: A prototype and usability test of an NFC-based virtual ticketing application. *Near Field Communication, International Workshop*, pp. 45–50.
- Glötz, M. F. (2018). Recycling with RFID technology. *Business Computing World*. Retrieved July 29, 2018, from <http://www.businesscomputingworld.co.uk/recycling-with-rfid-technology>.
- Isard, M., et al. (2007). Distributed data-parallel programs from sequential building blocks. *EuroSys, 2007*, 59–72.
- Microsoft technical documentation. (2001). What is a server cluster. Retrieved July 29, 2018, from [https://technet.microsoft.com/en-us/library/cc785197\(v=ws.10\).aspx](https://technet.microsoft.com/en-us/library/cc785197(v=ws.10).aspx).
- National Institute of Standards and Technology. (2001). Advanced Encryption Standard. Federal Information Processing Standards Publications. Retrieved March 27, 2018, from <http://csrc.nist.gov/publications/fips/fips197/fips-197.pdf>.
- OpenSSL Website. (2018). OpenSSL Library. Retrieved April 29, 2018, from <http://www.openssl.org>.
- Peng, W., & Su, D. (2015). Development of an online recycling monitoring system for customer electronic products using the internet. *NFC and RFID Technologies, Key Engineering Materials*, 486(2015), 81–86.
- Su, D., & Peng, W. (2014). Application of PDA and wireless technology in a server-client structure for remote machine condition monitoring. *Key Engineering Materials*, 450(2014), 449–452.
- Su, D., & Peng, W. (2015). Internet-based inter-operation infrastructure for data management within an ecological accounting system. In *Proceedings of the International Conference on Computer Science and Software Engineering (CSSE2014)*, 18–19 October (2015), Hangzhou, China, pp. 759–772.
- Thatte, S. M. (2010). *Persistent memory: A storage architecture for object-oriented database systems*. Asilomar, CA: Object-oriented database systems.
- Zhang, D. (2012). Radio frequency identification (RFID) technology. *Telecommunications Technology*, 2, 86–88.

# Chapter 7

## Social Life Cycle Assessment



You Wu and Daizhong Su

**Abstract** In this chapter, after a brief literature review, the social life cycle assessment (S-LCA) technology is introduced, including fundamental terminologies, steps for implementing an S-LCA, and seven major assessment methods. A case study is presented to illustrate how the procedure and relevant assessment methods are applied in the S-LCA of a company producing lighting products.

**Keywords** Life cycle assessment · LCA · Social life cycle assessment · S-LCA · Life cycle impact assessment · Impact assessment methods · Performance reference points · Lighting products

### 7.1 Introduction

The early work in social life cycle assessment (S-LCA) was reported by Fava et al. (1993) which was about the society and social-economic impacts within the life cycle framework discussed at the workshop ‘A Conceptual Framework for Life Cycle Impact Assessment’ hosted by the United States Environmental Protection Agency. This report proposed a concept of social life well-being category, investigated the direct and indirect environmental impacts caused by the society, and included the society impacts were into the framework of product life cycle environmental evaluation.

In the early of 2000, scholars proposed the framework for evaluating social impacts through life cycle, and the damage categories, impact categories, category indicators and inventory data for the evaluation framework (Weidema 2006; Dreyer et al. 2006; Benoît et al. 2007). Additionally, the method was introduced for the social life cycle evaluation and challenges related to the framework (Labuschagne and Brent 2006; Hunkeler 2006; Jørgensen et al. 2008).

---

Y. Wu (✉) · D. Su

Advanced Design and Manufacturing Engineering Centre, School of Architecture, Design and the Built Environment Nottingham Trent University, Nottingham, UK  
e-mail: [you.wu@ntu.ac.uk](mailto:you.wu@ntu.ac.uk)

D. Su

e-mail: [daizhong.su@ntu.ac.uk](mailto:daizhong.su@ntu.ac.uk)

© Springer Nature Switzerland AG 2020  
D. Su (ed.), *Sustainable Product Development*,  
[https://doi.org/10.1007/978-3-030-39149-2\\_7](https://doi.org/10.1007/978-3-030-39149-2_7)

In order to promote the implementation for social life cycle impact assessments, the United Nations Environment Programme (UNEP) and the Society of Environmental Toxicology and Chemistry (SETAC) developed 'Guidelines for Social Life Cycle Assessment of Products' (Benoît et al. 2009). The Guidelines give the definition of social LCA as 'a social impact (and potential impact) assessment technique that aims to assess the social and socio-economic aspects of products and their potential positive and negative impacts along their life cycle encompassing extraction and processing of raw materials; manufacturing; distribution; use; re-use; maintenance; recycling; and final disposal'. The guidelines also state that social LCA complements environmental LCA with social and socio-economic aspects. It can either be applied on its own or in combination with E-LCA. The Guidelines explain the rationale regarding the society impacts for products and provide a solid social impact evaluation framework.

There are several assessment methods developed by researchers for S-LCA. Benoît (2009) introduced two types of methods: (1) to select or create the impact categories based on the stakeholders' interests in social aspects, and to use the combined results of subcategories as the evaluation results of the impact categories; (2) to model the pathway from subcategory to impact category, and fill the evidence to evaluate the performance of the impact category and subcategory. Chhipi-Shrestha et al. (2015) defined 'performance reference point methods' and 'impact pathways methods'. The performance reference point methods assess social impacts using performance reference points based on internationally accepted minimum performance levels such as ILO1 conventions (Pörtl and Spiegel 2014). The impact pathways methods assess the social impacts of a product system using impact pathways as characterization models comprised of midpoint indicators and/or endpoint indicators similar to environmental LCA. These methods are based on social effects and use cause-effect chains to estimate the impacts. The widely applied methods are further introduced in Sect. 7.4.

This chapter will explain the procedures of implementing a product social life cycle assessment, review recent social life cycle assessment works, and demonstrate the social life cycle assessment with a case study of lighting products.

## 7.2 Fundamentals

According to the Guidelines mentioned above, there are four fundamental terminologies in relation to the social life cycle assessment, including stakeholder, impact category, subcategory and indicator which are defined as follows (Benoît et al. 2009).

**Stakeholder** A stakeholder category is a cluster of stakeholders who are expected to have shared interests in the investigated product systems. They can be categorized into: Worker, Local Community, Society, Consumer and Value chain actor.

The intention of establishing stakeholder categories is to provide a comprehensive basis for the articulation of the subcategories. The proposed stakeholder categories

are deemed to be the main group categories potentially impacted by the life cycle of a product.

**Impact Category** Impact Categories used in S-LCA correspond to the goal and scope of the study and represent social issues of interest that will be expressed regarding the stakeholders affected and may cover health and safety, human rights, working conditions, socio-economic repercussions, cultural heritage and governance.

**Subcategory** The subcategories are socially significant themes or attributes. Subcategories are classified according to stakeholder and impact categories and are assessed by the use of inventory indicators, and measured by unit of measurement (or variable).

**Indicator** The indicators of the social life cycle assessment act as the bridge that links the data with subcategories and impact categories, guiding the data collection process. They can be categorized into additive indicators and descriptive indicators. Descriptive indicators can be further divided into General indicators, which describe broad societal values, international standards top-down approach, and living wage; and Specific indicators, which focus on relevant impacts in a specific process or product (Benoît et al. 2009).

## 7.3 Steps for Implementing S-LCA

S-LCA complies the ISO 14040 standards, and therefore the four phases for environmental life cycle assessment are also applied for S-LCA, including Goal, Scope, System Boundaries and Functional Unit (Benoît et al. 2009), which are explained in the following sub-sections.

### 7.3.1 *Definition of Goal and Scope, System Boundaries and Functional Unit*

The goal of the S-LCA has to be clearly specified to ensure the proper study and implementation of S-LCA. The scope is defined in the first phase of the study that usually encompasses issues of the depth and breadth of the study.

The S-LCA assesses the social impact of the entire life cycle from cradle to grave (Jørgensen et al. 2008). It assesses the social and socio-economic impacts found in the life cycle and provides general data and specific data. The social-economic and social aspects assessed in S-LCA are those that may directly or indirectly affect the positive or negative aspects of the stakeholders in the product life cycle. The functional unit defines the service that needs to be delivered by the product, and ensures that the evaluation target is on an equal basis.

### ***7.3.2 Life Cycle Inventory Analysis***

Within the inventory phase of an S-LCA, the data are collected, the systems are modelled, and the life cycle impact results are obtained. The data to be collected are usually for the purposes of prioritization of actions to be taken in order to reduce the impact based on the S-LCA results, hotspots assessment, site specific evaluation, and impact characterization assessment.

The data collected in the inventory phase enable the assessment of the social impacts of the product's life cycle. Depending on the goal of the study, generic or case-specific data may be used. The Guidelines (Benoît et al. 2009) specify three different types of data that can be used in an S-LCA:

- the activity variables which serve to allocate a socially relevant weight to the different unit processes when dealing with qualitative and semi-quantitative indicators that cannot be referred to the functional unit directly.
- the data related to the social conditions or stressors that will be translated into impacts.
- the data necessary to compare the local situation to an international set of thresholds (the "Performance Reference Points" to be used in the characterization models).

### ***7.3.3 Life Cycle Impact Assessment***

The main object of this phase is to categorize the collected data, examine the data quality and use the established method to analysis these data (ISO 2006). The Guidelines mentioned in Sect. 7.1 above define three steps in this phase (Benoît et al. 2009):

- Selection of impact categories, characterization methods and models
- Linkage of inventory data to particular S-LCIA subcategories and impact categories
- Determination and/or calculation of subcategory indicator results

The main S-LCA methods that are widely used by the researchers will be presented in Sect. 7.4.

### ***7.3.4 Life Cycle Impact Interpretation***

Life Cycle impact interpretation is the process of assessing results in order to draw conclusions. In accordance with the goal and scope of the study, this phase has several objectives: to analyse the results, reach conclusions, explain the limitations of the study, provide recommendations and report adequately.

## 7.4 Main Assessment Methods for S-LCA

There are several assessment methods developed by researchers for S-LCA. Listed below are the brief introduction of the major methods used in this subject area.

### 7.4.1 *Performance Reference Point Method*

This method is to assess the relative position of the state of a unit process impact subcategory (or indicator) in reference to one or more international instruments or best practice (threshold). This type of data and assessment (using performance reference points) is common in the field of corporate social responsibility and is frequently used in S-LCA.

The reference points are usually based on internationally accepted minimum performance levels like the International labour organisation conventions, the ISO 26000 guidelines on social responsibility, and OECD Guidelines for Multinational Enterprises (ISO 2010; Parent et al. 2010). This method typically utilises scoring method for the impact subcategories and scoring aggregations for the final stakeholder category score or impact category score. The scoring methods can be two levels (e.g. yes or no, or 1 or 0) (Aparcana and Salhofer 2013; Foolmaun and Ramjeeawon 2013) or multi-level (Dreyer et al. 2006; Hutchins and Sutherland 2008; Ciroth and Franze 2011; Ekener-Petersen et al. 2014). They use a classification system based on the strength of the effect of social impacts, communicated with colour codes in a green–yellow–red scale.

In the Guidelines, there is a proposal to use performance reference points, these being ‘internationally set thresholds or goals or objectives according to conventions and best practices’ (Benoît et al. 2009). The advantage with this approach is that it represents a clear and intuitive way of communicating the results to interested stakeholders. Additionally, this method helps understand the magnitude and the significance of the data collected in the inventory phase.

### 7.4.2 *Impact Pathway Method*

Impact pathway method assesses the social impacts of products or services by utilising impact pathways as characterisation models that consist of midpoint and endpoint indicators like environmental LCA (Parent et al. 2010). This method is based upon the causal relationship between processes. For example, requiring excessive working time may cause workers to experience higher stress levels; high stress levels may cause depression (a midpoint); depression will result in a loss of psychological wellbeing (endpoints).



There are two typical characterisation frameworks for the impact pathway method: single impact pathway that measures a single social issue, and multiple impact pathways. Some case studies with single impact pathway focused on AoP (area of protection) of human (Norris 2006; Hutchins and Sutherland 2008; Feschet et al. 2013). They established the causal relationships between national health improvement (e.g. life expectancy or infant mortality) and economic growth (e.g. GDP). Except the fields of public health and epidemiology, there are limited studies in the search for social impact pathways case studies.

Petti et al. (2014) reviewed 35 publications related to S-LCA case studies. Among those publications, 68% carried out the case study by using the reference point method, while 6% implemented the impact pathway method. This does not mean that the reference point method is better, but rather the impact pathway method is difficult to classify the impact pathways and collect relevant and specific date of a product or service. It was concluded that the reference point method measures the overall social performance which relates to the relative importance of each context unit over the entire product system (Parent et al. 2010). Whereas the impact pathway method measures the social impacts of specific products which relates to the functional unit stated in assessment.

### 7.4.3 Checklist Method

The checklist-based impact assessment method uses the tick (✓) sign against the presence of an impact. This method can only conclude the evaluated impact exist or not. Ciroth and Franze (2011) compared the social life cycle impacts for rose flowers from the Ecuador and Netherland, with focus on production and packaging stages. The rationale for evaluating the impact performance can be described as follows:

- If the subcategory affects impact categories, then the impact categories are marked with '✓'.
- IF the subcategory doesn't affect impact categories, then the impact categories are marked with '—'.
- If there is no effect between the subcategory and impact category, or there is no evidence support the evaluation, then the impact category is left with blank
- The assessment column is marked with five level colours. The impact category row with the most '✓' will be marked with the darkest colour in the row assessment box. The impact category row with the least '✓' will be marked with the lightest colour in the row assessment box.

Through comparison between the assessment forms, it can be found that the social impacts for rose flowers produced in the Ecuador are worse than the rose flowers products in the Netherland.

### **7.4.4 Scoring Method**

The scoring method uses scores to assess an impact. A variety of scoring methods and standards have been developed to apply in the implementation of product S-LCA. Foolmaun and Ramjeeawon (2013) investigated the social impacts of four solutions for recycled PET bottles in Mauritius. Questionnaire was used to collect the evidences according to the established subcategories and indicators, and the collected data and information are then converted into quantitative figures by applying the established scoring standards. For example, the number of workers answering 'yes' to the question on wage satisfaction in the survey, which would represent the fraction of the sampled population of workers satisfied with their wages. Then mark the percentages of each subcategory based on the established scoring standards and calculate the total scores of each subcategory for the disposal procedures. Scoring for each solution is based on the percentages of each disposal procedure, in order to determine which solution is the appropriate one, the analysis shows 75% flake production and 25% landfilling is the best solution for this case.

Another scoring method was used by Ciroth and Franze (2011) where negative and positive impacts are rated by assigning values from 1 to 6 (1 for positive and 6 for very negative impacts). However, there are arguable elements such as assessing the lack of forced labour as a positive aspect, whilst this merely put it back to neutral impacts at the best.

### **7.4.5 Database Method**

According to the literature search, the Social Hotspot Database (Norris et al. 2012) and PSILCA (Ciroth and Eisfeldt 2017) are the two major databases applicable in S-LCA practices. Both database comply with the categories and indicators framework that are defined by the Guidelines (Benoît et al. 2009) and 'The Methodological Sheets' (UNEP-SETAC 2013). Global government and organizational statistics reports are the main data sources for the two databases that cover hundreds of nations and regions, and sectors. Using the database to model the product system for S-LCA and conduct the evaluation is time-efficient for the data collection phase.

Ekener-Petersen et al. (2014) implemented screening level S-LCA for fossil fuels and biofuels for vehicles by using SHDB data and concluded that it is clearly shown that there are risks of substantial negative social impacts from fossil fuels, at the same levels as for biofuels. Ekener et al. (2018) also integrated the different sustainability perspectives into one holistic outcome for sustainability by considering different stakeholder profiles and negative as well as positive social impacts, which is also validated in the case of biomass based and fossil transportation fuels. The analysis results show that it is important to include positive social impact categories for the future S-LCA practices (Ekener et al. 2018) as the existing S-LCA studies has limited considerations for the positive impacts.

The database PSILCA v2.1 (Ciroth and Eisfeldt 2017) was used to establish the background system's inventory of small-scale apparel product chains in Peru, in order to increase consumer transparency and social awareness (Villegas et al. 2018). The PSILCA database also provided background information for the stakeholder of rural cassava starch factories in Cauca-Colombia, and the greatest impacts occur in the cassava producers among all the stakeholders. The analysis results show that positive impacts can be generated regarding job creation, food security/sovereignty, gender equality, gender wage gaps, food security and sovereignty, and others (Güereca 2018).

Werker et al. (2018) used PSILCA to implement S-LCA for industrial hydrogen production by alkaline water electrolysis that is produced in Switzerland and operating in Germany. PSILCA provides sector level data for a risk level of 19.5 medium risk hours for hydrogen production in Germany).

Eynard et al. (2018) used PSILCA to perform a macro-scale assessment of social performance of the mining and quarrying sector in six extra-EU countries, compared to the EU-28 average. This analysis results show that in the case of the EU mining and quarrying sector, the three top locations contributing to the social indicator for the impact category "fair salary" are India, China and UK.

Note that the S-LCA databases covers many different aspects related to social sustainability. However, in some cases the existing databases, such as PSILCA and SHDB, have limitations in representing specifically how an economic sector affects social conditions. Indeed, many indicators refer to the situation of the country rather than reflecting sectors performance (Mancini and Sala 2018).

#### ***7.4.6 Empirical Method***

The empirical method involves the use of empirical formulas or rules in order to assess social impacts. Weidema (2006) proposed QALYs (Quality Adjusted Life Years) as the functional unit for the Human Being which is similar to the functional unit DALYs (Disability Adjusted Life Years) in the practices of environmental life cycle assessment. Labuschagne and Brent (2006) developed a quantitative based formula to evaluate social life cycle impacts based on the South Africa Resource Impact Indicator approach. Feschet et al. (2013) used Preston Pathway (curve) to evaluate the health, education, employment impacts that related to the banana industry in the Cameroon.

#### ***7.4.7 Environmental Life Cycle Inventory Database Method***

In environmental LCI database method, the environmental LCI database is used for estimating social impacts. This approach is similar to environmental life cycle impact assessment, therefore, the functional unit, system boundary of the social life cycle is required to keep consistent with the settings for the environmental life cycle.

Additionally, this method can only evaluate the impact performance related to the health and employment aspects instead of the all range impact categories that are defined by the Guidelines (Benoît et al. 2009).

## 7.5 Case Study

This section is to demonstrate the S-LCA for a lighting product manufacturing company. Due to a confidentiality reason, the company's name cannot be mentioned. In this case study, the S-LCA is focused on the company's aspects related to the manufacture phase of the lighting products. This assessment is conducted using the checklist method, scoring method and reference points method.

### 7.5.1 *The Schematic and Rating Scale*

The stakeholder category and subcategory selection following the Guidelines (Benoît et al. 2009) and the indicator selection are confirmed first in the S-LCA process, which are presented in Table 7.2.

Within the S-LCA, not only the impacts but also the performance of the company have to be assessed. The performance is assessed by comparison to the Performance Reference Points (see Appendix 7.1), with assessment results shown in the third column of Table 7.3. The impact is assessed against the impact categories, which include Working conditions, Health and safety, Human rights, socio-economic repercussions, Indigenous rights, and Governance, as shown in Table 7.3 where each fields of impact categories are signed  $\checkmark$  or ( $\checkmark$ ) for the one with high or low influence on the society aspects, and (–) for not relevant or data not available.

The data collection is indispensable to the inventory analysis process. The indicator performance is illustrated by the data presented in the last column (Status) of Table 7.2. The data were collected from relevant sources such as the company's annual reports and Website. Both the social performance and the social impact are assessed based on data shown in the Status column of Table 7.2.

Each subcategory is assessed twice, one for the performance assessment and the other for the impact assessment, with a colour system ranging from very good performance to very poor performance, and positive effects to negative effects, by following the grades presented in Table 7.1.

As indicated in Table 7.1, the factor values are arranged from 1 to 6, of which a lower value is better, while a higher value is worse. In this case study, as shown in Table 7.3, the sub-score of subcategories for a stakeholder category is the average value of the factors assigned to the subcategories of the corresponding stakeholder group, and the final aggregate score is the average value of the sub-scores. Please note that this a simplified method for an indication purpose only. For a more accurate calculation method, please see (Ciroth and Franze 2011).

**Table 7.1** The rating scale (Ciroth and Franze 2011)

Performance assessment	Impact assessment	Colour	Factor
Very good performance	Positive effect		1
Good performance	Lightly positive effect		2
Satisfactory performance	Indifferent effect		3
Inadequate performance	Lightly negative effect		4
Poor performance	Negative effect		5
Very poor performance	Very negative effect		6

## 7.5.2 Life Cycle Inventory Analysis

As shown in Tables 7.2 and 7.3, in this case study, four stakeholders are selected: workers, consumer, local community, and society. The numbers of subcategories and indicators for each stakeholder category are as follows:

- 5 subcategories and 12 indicators are defined for the Worker stakeholder category
- 5 subcategories and 7 indicators are defined for the Consumer stakeholder category
- 3 subcategories and 3 indicators are defined for the Local Community stakeholder category
- 3 subcategories and 5 indicators are defined for the Society stakeholder category

These factors are defined based on the identified data and information that are presented in Table 7.3.

### 7.5.2.1 Workers

#### (1) Assessment of the Discrimination subcategory

Two indicators are considered for this subcategory: ‘presence of formal policies of equal opportunities’, and ‘gender discrimination’, while the third indicator ‘percentage of woman in labour force in country/sector/organization’ is not considered because there is no data available. Based on the data collected, which are shown the last ‘Status’ column in Table 7.2, the performance and impact of this subcategory against the two indicators are assessed as follows.

For the indicator ‘presence of formal policies of equal opportunities’, the status data indicate that the company implemented the policies of equal opportunities by realizing a culture of performance with human resource management practices, high quality feedback, transparency and acting on performance and talent outcomes. Therefore, the company had positive facts regarding this indicator.

For the indicator ‘gender discrimination’, the company’s annual report shows that the overall gender ratio of female to male was 35/65 in 2017, i.e., the member of male staff was almost two times of female staff members. This is a negative fact. However, the recent data shows that the overall ratio smoothly grows, which means that the company’s gender situation is improving.

Table 7.2 S-LCA table of the company

Stakeholder	Subcategory	Indicator	Status
Workers	Discrimination	Presence of formal policies of equal opportunities	Realizing a culture of performance was grounded in proper human resource management practices, high quality feedback, transparency and acting on performance and talent outcomes. The company paid attention to individual staff member's career development, and support the employees to gain skills and updating knowledge with relevant technologies such as automation and artificial Intelligence
		Gender discrimination	In 2017, the rate of female and male in staff is 42/58 professional 31/69, management, 23/77, executives, 18/82, in total, 35/65. However, this situation slightly improved from that of 2015–2016
	Health and safety	Percentage of woman in labour force in country/sector/organization	No data
		Accident rate of the country/sector/organization	In the company, Health and Safety performance has continued to improve. A number of sites showed outstanding safety performance, for example, the Healthcare Pune site in India reached a significant milestone by achieving over 3 million man-hours without a Lost Workday Injury Case (LWIC) by the end of 2015 (over 3 years without an accident). Consumer Lifestyle implemented a Lean Behaviour Based Safety program resulting in significant improvement in both incident statistics and overall safe behaviour for the entire site. It is viewed as an internal best practice program with plans to be deployed globally at all manufacturing units within the company beginning in 2016, the rate of Lost Workday Injury Case (LWIC) 2011–2015 ranking from 0.67–0.34
	Description of protection measures	The company considered that job is a part of life, therefore they provided welfare and health insurance to protect their staff mentally and physically healthy	

(continued)

Table 7.2 (continued)

Stakeholder	Subcategory	Indicator	Status
		Description of reported violations	At present, there is no data reported about violations of the company
	Child labour	Percentage of child labour in country/sector/organization	The company published an official document of child labour policy, they defined the child labour as those under 15 years old and cited the ILO standards to reduced hiring child labour in the company's policy documents to stop hiring the underage child
		Kind of child labour in the company	The company presented that child labour problems cannot be avoided, and they endeavour to protect the child in case of injury (Koninklijke Philips 2015). No data were found about the child labour rates
	Working hours	Hours of work per employee and month in average	The working time of workday is 9:00 am–6:00 pm, therefore the average working time per month is roughly 200 h
		Working over time	Some former employees of the company complained that the company had wrong human resource arrangement and overtime work, which was the reason why they quitted their job
	Labour force	Frequency of forced labour in country/sector/enterprise	No data
		Description of kind of forced labour in the company	No data
Consumer	Health and safety	Presence of consumer complaints	With the results of analysing the views of the company's lighting product shown in e-commerce platform TIANMAO, there were positive remarks of the products produced by the company

(continued)

**Table 7.2** (continued)

Stakeholder	Subcategory	Indicator	Status
		Risks of the product regarding consumers health and safety	No data
	Consumer privacy	Related publications to protect consumer privacy	The company has a longstanding commitment to respect the privacy of their consumers, customers and other individuals. As the company transform into a digital company, complying with the company privacy standards is increasingly important to achieve that commitment
	Transparency	Presence of certifications or labels for the products/sites	To create a global approach on the protection of privacy and to allow internal data transfers between the companies worldwide, the company has adopted a set of Binding Corporate Rules
		Percentage of organizations within the sector which published a sustainability report	The company publish a wide range reports explaining the company's efforts in the improvement of sustainability performance
	End of life responsibility	The rate of recycle in the products	The company places greater emphasis on circular economic, they continue to make positive progress towards a circular economy by recycling 69% of industrial wastes. At the end of 2017, 3 out of 5 Connected Care & Health Informatics businesses' manufacturing sites reported zero waste to land. Based on detailed action plans the company works closely with the remaining sites to achieve zero waste to land status by the end of 2020
		Attention to management of end-of-life issues	Evidences were shown in the company's annual report 2017
Society	Contribution to economic development	Contribution of the product/company to economic development	The quota of the company selling in total from 53 million in 2015 to 55 million in 2016

(continued)



Table 7.2 (continued)

Stakeholder	Subcategory	Indicator	Status
	Technology development	Sector efforts in technology development regarding eco-friendliness	No data
		Presence of partnership regarding research and development	The company endeavour to use advanced technology to protect people health and safety. with the partner shared the same commitments
	Corruption	Risk corruption in country/sector	Some former employees complained that that the company had a serious corruption problem, which lead to wrong human arrangement and overtime work
Presence of anti-corruption program in the company		No data	



With the above analysis and reference to the Performance Reference Points regarding Discrimination: ‘no occurred of discrimination further, companies should employ minorities and the employment ratio men and women should be balanced’ (see Appendix 7.1), it can be concluded that discrimination exists in the company in term of the second indicator, but there also have some positive aspects regarding the first indicator. Therefore, the performance score for this subcategory is 4 points. Although the influences in the impact category working conditions and health and safety are relatively small, and the rest impact categories are much bigger, therefore, the impact assessment are scored as 5 points.

## (2) **Health and Safety**

The company’s annual report shows that company’s health and safety performance has continued to improve and has an excellent performance in the area. The Lost Workday Injury Case (LWIC) use a datum to assess the enterprise performance in the health and safety, and it reported that the injury rate keeps falling from 2011 to 2015, ranking in 0.67 to 0.34 in the lighting industry. The company has taken various measures to protection their labour, they considered that job is a part of life, and they provided welfare and health insurance to protect their staff mentally and physically healthy. At present, there is no violation incidents reported. Compared to the regulation in the performance reference points, ‘adequate management of health and safety, so that the risk of workers is low’, the score of performance assessment is 1 point because the three indicators show positive effects. The impact assessment is scored and remained as 1, because the impact category shows a bigger influence in all areas.

## (3) **Child Labour**

The performance of Child Labour is represented by two indicators: the percentage of child labour, and kind of child labour in the company. The company published an official company child labour policy to define that the child labour as children who under 15 years and is assigned different working intensity and working hours to children of different ages. At present the company doesn’t declare the number of child labours employed in the company, but the company admits that child hiring labour is an inevitable matter. Therefore, the policies are established to protect the benefits of their child labour. On the other hand, the company does not specify which type of child labour the company uses, according to the ratio of child labour in different countries, it could be concluded that the type of force is labour-intensive job and in developing countries. These findings show that the company is incompatible to the performance reference points ‘no occurrence of child labour’. No matter what the performance they have, they show a positive attitude to the child labour and use clear policies to protect their benefits. Thus, the performance of child labour is defined as 3 in the assessment, the impact assessment is scored in 4 because the impact category cause bigger influence indigenous rights.

#### (4) Working Hours

There are two indicators: ‘hours of work per employee and month in average’ and ‘over time’. The working time of workday is 9:00–6:00, therefore the average working time per month is approximately 200 h. The performance reference point regulated that ‘the length of the working hours far exceeds the working time should not exceed 8 h per day and 48 h per week’. Therefore, the company has shown unsatisfied performance in this perspective, so the score is defined as 5 points. In the performance of the impact category, there is a smaller impact on the working condition and the indigenous rights, so the score on the impact assessment is 3 points.

#### (5) Forced Labour

There is no data and information available to support the assessment.

### 7.5.2.2 Consumer

#### (1) Health and Safety

There are two indicators for the health and safety subcategory: presence of consumer complaints, and risk of product regarding consumer health and safety. Based on the information obtained from e-commerce Websites, the findings show that majority of the consumers highly praise the the company’s products, and the few complaints are caused by the delivery services that are provided by the third professional logistical company. Furthermore, the online consumer review shows that the best-selling lamp products of the company are commented with very high rate. Performance reference point regulated that ‘the company should minimize health and safety risks of products’, and the company’s performance in this perspective is also positive. Therefore, the performance score is 2 points, and all the impact categories have high impact, so the impact assessment is scored with 1 point.

#### (2) Consumer Privacy

In the respect of consumer privacy, two indicators are involved: related publications and protect consumer privacy, the company has a longstanding commitment to respect the privacy of consumers, and has established the privacy rules specifying reasons for customer data, and strict confidentiality protocol. From the performance reference points stipulated by ‘companies should conduct regarding their product and social responsibility in a transparency way, the communication should enable an informed consumer choice’, the company shows good performance in this respect, but the risk of leaking data stills exists, therefore, the performance assessment is set as 2 points. In terms of impact subcategories, there is a smaller impact on working conditions, socio-repercussions, and indigenous, so the performance on impact assessment keeps consistent, and the score is still 2 points.

### (3) **Transparency**

There are two indicators in the aspect of transparency subcategory: presence of certification or labels for the products/sites, and the percentage of organizations within the sector which publishes the sustainability reports. The company created a global approach on the protection of privacy and allows internal data transfer between its companies worldwide; additionally, the company has adopted a set of Binding Corporate Rules regarding Privacy Rules. In the performance reference points, it is stated that ‘company should communicate regarding their product and social responsibility in a transparent way the communication should enable an informed consumer choice’; therefore, the performance assessment is set at 2 points. In terms of impact subcategories, there is a bigger impact on all aspects, so the score is defined as 2 points.

### (4) **End of Life Responsibility**

There are two indicators in the end of life responsibilities: the recycle rates of the products, and attention to management of end-of-life issues. The company’s 2017 annual report indicates that the company made great efforts to the circular economy and the recycling rate of industrial waste reached 69%, but there is still a part of non-recyclable industrial waste that needs to be landfilled. In 2012, they achieved zero waste development goals. In the performance reference points, companies should provide information to consumers regarding appropriate end-of-life options, if relevant manufactures of electronic products should establish product take back systems and should secure appropriate product disposal’. The company performs well in this perspective, so the score is 2 points, furthermore, it has a large impact on impact subcategories, and the score for impact assessment is 1 point.

## **7.5.2.3 Society**

### (1) **Contribution to Economic**

The indicator of contribution to economic is the contribution of the product/company to economic development. The company’s total sale quota increase from 53 million in 2015 to 55 million in 2016, and the sales of lamps manufactured by the company reached 5.5 billion in 2016. The performance reference points ‘The company should contribute the local economic development through different aspects as payment of wages purchase of raw materials and supplies investments etc’. Because the company has a positive impact on the economy, resulting in good results in the performance assessment, then it is scored as 1 points, and the impact category is also obtained 1 point.

### (2) **Technology Development**

There are two indicators for the technology development: sector efforts in technology development regarding eco-friendliness, and presence of partnership regarding

research and development. The company endeavours to use advanced technology to protect people's health and safety. In the performance reference points, it is stated that 'companies acting in technology relevant areas should engage in the development of efficient and environmental sound technologies'. Thus, it can conclude that the company has good performance, so the score is 1 point, and the impact category is also obtained 1 point.

### (3) **Corruption**

The staff members of the company complained that the company serves a serious corruption problem, which resulted in wrong human arrangement and overtime work. The Performance reference points indicate that 'companies should not be involved into cases of corruption and should implement appropriate measures to prevent corruption'. The company should endeavour to cope with these issues for a better performance, and hence resulted in 4 points for this category. Through the evaluation of the impact categories, there are two smaller influences and 4 bigger influences leading to a score of 5 points to the resulting impact assessment.

### **7.5.3 Comments on the Assessment Results**

The results reveal the following positive aspects of the S-LCA for the company in relation to the production of their lighting products:

- The overall social performance assessments (PA) and impact assessments (IA) of the company are resulted with aggregate scores 2.41 and 2.27 respectively. Considering the range of the score is 1.00–6.00, the results are reasonably good.
- It is particularly good for the subcategories of health and safety, Contribution to economic, and Technology development, with score 1 of both PA and IA for all the three subcategories.

However, considerable attention must be given to improve to the following subcategories

- Discrimination with assessment scores PA = 4 and IA = 5,
- Child labour with scores of PA = 3 and IA = 4.

It has to point out that this case study is for illustration purpose only in order for the reader to understand the assessment procedure and application of relevant assessment methods, but the data collected are not sufficient enough to give more accurate assessment results.

## 7.6 Concluding Remarks

This chapter is an introductory of the S-LCA, including the fundamental terminologies, S-LCA procedure, assessment methods, and a case study to illustrate the application of the assessment methods to the S-LCA of a lighting company.

The information presented in this chapter is valuable for the reader to understand the S-LCA technology. The review of S-LCA methods and the case study are particularly helpful to understand the assessment procedure and application of relevant assessment methods.

**Acknowledgements** The authors are grateful for the contributions to this article made by Miss Chang Xu and Miss Meidan Wang, visiting students from the Harbin Engineering University (HEU), China, supported by the HEU Visiting Scholar grants.

## Appendix

### Appendix 7.1 List of Performance Reference Points (Ciroth and Franze 2011)

Subcategory	Performance Reference Point	Basis
Freedom of association and collective bargaining	Freedom of association and collective bargaining should be ensured. The forming and joining of independent trade unions should be possible.	<ul style="list-style-type: none"> <li>• ILO labour standards</li> <li>• UN Declaration on Human Rights</li> <li>• OECD Guidelines for Multinational Enterprises</li> <li>• UN Global Compact</li> <li>• IFC Performance Standards on Social and Environmental Sustainability</li> <li>• The Global Sullivan Principles</li> <li>• UNEP/SETAC method sheets</li> </ul>
Child labour	No occurrence of child labour.	<ul style="list-style-type: none"> <li>• ILO labour standards</li> <li>• OECD Guidelines for Multinational Enterprises</li> <li>• UN Global Compact</li> <li>• IFC Performance Standards on Social and Environmental Sustainability</li> <li>• The Global Sullivan Principles</li> <li>• UNEP/SETAC method sheets</li> </ul>
Forced labour	No occurrence of forced labour.	<ul style="list-style-type: none"> <li>• ILO labour standards</li> <li>• OECD Guidelines for Multinational Enterprises</li> <li>• UN Global Compact</li> <li>• IFC Performance Standards on Social and Environmental Sustainability</li> <li>• The Global Sullivan Principles</li> <li>• UNEP/SETAC method sheets</li> </ul>

(continued)

(continued)

Subcategory	Performance Reference Point	Basis
Fair salary	The wage level should ensure a decent standard of living. The payment of the minimum wage is often not sufficient. Further, companies should pay in time and do not withhold shares of the salary.	<ul style="list-style-type: none"> <li>• ILO labour standards</li> <li>• UN Declaration on Human Rights</li> <li>• The Global Sullivan Principles</li> <li>• UNEP/SETAC method sheets</li> </ul>
Working time	The working time should not exceed 8 hours per day and 48 hours per week.	<ul style="list-style-type: none"> <li>• ILO labour standards</li> <li>• UNEP/SETAC method sheets</li> </ul>
Discrimination	No occurrence of discrimination. Further, companies should employ minorities and the employment ratio men to women should be balanced.	<ul style="list-style-type: none"> <li>• ILO labour standards</li> <li>• UN Declaration on Human Rights</li> <li>• OECD Guidelines for Multinational Enterprises</li> <li>• UN Global Compact</li> <li>• IFC Performance Standards on Social and Environmental Sustainability</li> <li>• The Global Sullivan Principles</li> <li>• UNEP/SETAC method sheets</li> </ul>
Health and safety	Adequate management of health and safety, so that the risk of workers is low.	<ul style="list-style-type: none"> <li>• ILO labour standards</li> <li>• ISO 26000</li> <li>• IFC Performance Standards on Social and Environmental Sustainability</li> <li>• The Global Sullivan Principles</li> <li>• UNEP/SETAC method sheets</li> </ul>
Social benefits/social security	Companies should provide social benefits as for instance medical insurance or pension insurance, which ensure a decent standard of living. Other social benefits as swimming pools, staff cars, or the like are classified as rather unimportant.	<ul style="list-style-type: none"> <li>• ILO labour standards</li> <li>• UNEP/SETAC method sheets</li> </ul>
Access to material resources	Companies should not overexploit material resources and should implement certified environmental management systems to minimise resource consumption. In addition, companies should improve community infrastructure, if the infrastructure is underdeveloped or not sufficient for a decent standard of living.	<ul style="list-style-type: none"> <li>• UN Declaration on Human Rights</li> <li>• ISO 26000</li> <li>• ISO 14000</li> <li>• OECD Guidelines for Multinational Enterprises</li> <li>• UN Global Compact</li> <li>• IFC Performance Standards on Social and Environmental Sustainability</li> <li>• The Global Sullivan Principles</li> <li>• UNEP/SETAC method sheets</li> </ul>

(continued)



(continued)

Subcategory	Performance Reference Point	Basis
Access to immaterial resources	Companies should provide for one thing freedom of expression; for another thing they should support communities in education or other community services, if necessary.	<ul style="list-style-type: none"> <li>• UN Declaration on Human Rights</li> <li>• The Global Sullivan Principles</li> <li>• UNEP/SETAC method sheets</li> </ul>
Delocalisation and migration	Companies should not cause resettlements or migration movements on a large scale. If resettlements are necessary companies should provide appropriate compensations.	<ul style="list-style-type: none"> <li>• UN Declaration on Human Rights</li> <li>• IFC Performance Standards on Social and Environmental Sustainability</li> <li>• UNEP/SETAC method sheets</li> </ul>
Cultural heritage	Companies should respect cultural heritage and do not infringe cultural customs and traditions in any way.	<ul style="list-style-type: none"> <li>• UN Declaration on Human Rights</li> <li>• ILO conventions</li> <li>• Universal Declaration on Cultural Diversity</li> <li>• IFC Performance Standards on Social and Environmental Sustainability</li> <li>• UNEP/SETAC method sheets</li> </ul>
Respect of indigenous rights	Companies should respect indigenous rights, including the rights to lands, resources, cultural integrity, self-determination, and self-government.	<ul style="list-style-type: none"> <li>• UN Declaration on Human Rights</li> <li>• Indigenous rights</li> <li>• ILO conventions</li> <li>• UN Declaration on the Rights of Indigenous Peoples</li> <li>• IFC Performance Standards on Social and Environmental Sustainability</li> <li>• UNEP/SETAC method sheets</li> </ul>
Safe and healthy living conditions	Companies should minimise their environmental pollution in order not to jeopardise the health of community members.	<ul style="list-style-type: none"> <li>• UN Declaration on Human Rights</li> <li>• ISO 26000</li> <li>• IFC Performance Standards on Social and Environmental Sustainability</li> <li>• The Global Sullivan Principles</li> <li>• UNEP/SETAC method sheets</li> </ul>
Secure living conditions	In countries with high crime rates companies should contribute to secure living conditions through private security personnel.	<ul style="list-style-type: none"> <li>• UN Declaration on Human Rights</li> <li>• IFC Performance Standards on Social and Environmental Sustainability</li> <li>• UNEP/SETAC method sheets</li> </ul>
Local employment	Companies should contribute directly or indirectly through local suppliers to the reduction of local unemployment.	<ul style="list-style-type: none"> <li>• ISO 26000</li> <li>• OECD Guidelines for Multinational Enterprises</li> <li>• ILO conventions</li> <li>• UNEP/SETAC method sheets</li> </ul>

(continued)

(continued)

Subcategory	Performance Reference Point	Basis
Community engagement	Companies should engage in their communities in different areas. In addition, companies should include community stakeholders in relevant decision-making processes.	<ul style="list-style-type: none"> <li>• ISO 26000</li> <li>• OECD Guidelines for Multinational Enterprises</li> <li>• IFC Performance Standards on Social and Environmental Sustainability</li> <li>• The Global Sullivan Principles</li> <li>• UNEP/SETAC method sheets</li> </ul>
Public commitments to sustainable issues	Companies should contribute to the sustainable development of the society with regard to the impacts from their activities.	<ul style="list-style-type: none"> <li>• OECD Guidelines for Multinational Enterprises</li> <li>• UNEP/SETAC method sheets</li> </ul>
Contribution to economic development	Companies should contribute the local economic development through different aspects as payment of wages, purchase of raw materials and supplies, investments etc.	<ul style="list-style-type: none"> <li>• ISO 26000</li> <li>• OECD Guidelines for Multinational Enterprises</li> <li>• UNEP/SETAC method sheets</li> </ul>
Prevention and mitigation of conflicts	Companies located in regions with a high risk of conflicts due to resource depletion, massive pollution or poor working standards should try to reduce the risk by dint of appropriate measures.	<ul style="list-style-type: none"> <li>• UNEP/SETAC method sheets</li> </ul>
Technology development	Companies acting in technology relevant areas should engage in the development of efficient and environ- mental sound technologies.	<ul style="list-style-type: none"> <li>• ISO 26000</li> <li>• OECD Guidelines for Multinational Enterprises</li> <li>• UN Global Compact</li> <li>• UNEP/SETAC method sheets</li> </ul>
Corruption	Companies should not be involved into cases of corruption and should implement appropriate measures to prevent corruption.	<ul style="list-style-type: none"> <li>• ISO 26000</li> <li>• OECD Guidelines for Multinational Enterprises</li> <li>• UN Global Compact</li> <li>• The Global Sullivan Principles</li> <li>• The Global Sullivan Principles</li> </ul>
Fair competition	Companies should act fair, i.e. not anti-competitive.	<ul style="list-style-type: none"> <li>• ISO 26000</li> <li>• OECD Guidelines for Multinational Enterprises</li> <li>• United Nations Set of principles and rules on competition</li> <li>• The Global Sullivan Principles</li> <li>• UNEP/SETAC method sheets</li> </ul>

(continued)

(continued)

Subcategory	Performance Reference Point	Basis
Promoting social responsibility	Companies should promote social responsibility among suppliers, including monitoring, audits, and training with regard to social responsible behaviour.	<ul style="list-style-type: none"> <li>• ISO 26000</li> <li>• OECD Guidelines for Multinational Enterprises</li> <li>• IFC Performance Standards on Social and Environmental Sustainability</li> <li>• The Global Sullivan Principles</li> <li>• UNEP/SETAC method sheets</li> </ul>
Supplier relationships	Companies should develop supplier relationships, which base on mutual co-operation. Companies should act fair regarding their suppliers and should support them, if necessary.	<ul style="list-style-type: none"> <li>• UNEP/SETAC method sheets</li> </ul>
Respect of intellectual property rights	Companies should respect intellectual property rights and should not infringe patent rights.	<ul style="list-style-type: none"> <li>• ISO 26000</li> <li>• The Global Sullivan Principles</li> <li>• UNEP/SETAC method sheets</li> </ul>
Health and safety	Companies should minimise health and safety risks of products.	<ul style="list-style-type: none"> <li>• ISO 26000</li> <li>• OECD Guidelines for Multinational Enterprises</li> <li>• UNEP/SETAC method sheets</li> </ul>
Feedback mechanism	Companies should implement feedback mechanisms to come in contact with consumers in an uncomplicated way.	<ul style="list-style-type: none"> <li>• ISO 26000</li> <li>• OECD Guidelines for Multinational Enterprises</li> <li>• UNEP/SETAC method sheets</li> </ul>
Transparency	Companies should communicate regarding their product and social responsibility in a transparent way. The communication should enable an informed consumer choice.	<ul style="list-style-type: none"> <li>• ISO 26000</li> <li>• OECD Guidelines for Multinational Enterprises</li> <li>• UNEP/SETAC method sheets</li> <li>• UNEP/SETAC method sheets</li> </ul>
End of life responsibility	Companies should provide information to consumers regarding appropriate end-of-life options, if relevant. Manufactures of electronic products should establish product take back systems and should ensure appropriate product disposal.	<ul style="list-style-type: none"> <li>• WEEE directive</li> <li>• UNEP/SETAC method sheets</li> </ul>

## References

- Aparcana, S., & Salhofer, S. (2013). Application of a methodology for the social life cycle assessment of recycling systems in low income countries: three Peruvian case studies. *The International Journal of Life Cycle Assessment Springer*, 18(5), 1116–1128.
- Benoît, C. et al. (2009). Guidelines for social life cycle assessment of products. Belgium: UNEP/SETAC Life Cycle Initiative (Druk in de weer). [http://www.unep.fr/shared/publications/pdf/DTIx1164xPA-guidelines\\_sLCA.pdf](http://www.unep.fr/shared/publications/pdf/DTIx1164xPA-guidelines_sLCA.pdf).
- Benoît, C. et al. (2007). Developing a methodology for social life cycle assessment : The North American Tomato's CSR case. *Analysis*. Retrieved April 21, 2018, from <http://userpage.fu-berlin.de/~ffu/calcas/Benoit.pdf>.
- Chhipi-Shrestha, G. K., Hewage, K., & Sadiq, R. (2015). 'Socializing' sustainability: a critical review on current development status of social life cycle impact assessment method. *Clean Technologies and Environmental Policy*, 17(3), 579–596.
- Ciroth, A., & Eisfeldt, F. (2017). PSILCA—A product social impact life cycle assessment database—Database version 2.1', *GreenDelta GmbH*, 1. [http://www.openlca.org/wp-content/uploads/2017/12/PSILCA\\_documentation\\_update\\_PSILCA\\_v2\\_final.pdf](http://www.openlca.org/wp-content/uploads/2017/12/PSILCA_documentation_update_PSILCA_v2_final.pdf).
- Ciroth, A., & Franze, J. (2011). *LCA of an Ecolabeled Notebook: consideration of social and environmental impacts along the entire life cycle*. Lulu. com. Retrieved April 21, 2018, from [http://www.greendelta.com/uploads/media/LCA\\_Notebook.pdf](http://www.greendelta.com/uploads/media/LCA_Notebook.pdf).
- Dreyer, L., Hauschild, M., & Schierbeck, J. (2006). A framework for social life cycle impact assessment. *International Journal of Life Cycle Assessment Springer*, 11(2), 88–97. <https://doi.org/10.1065/lca2005.08.223>.
- Ekener-Petersen, E., Höglund, J., & Finnveden, G. (2014). Screening potential social impacts of fossil fuels and biofuels for vehicles. *Energy Policy Elsevier*, 73, 416–426.
- Ekener, E., Hansson, J., & Gustavsson, M. (2018). Addressing positive impacts in social LCA—discussing current and new approaches exemplified by the case of vehicle fuels. *The International Journal of Life Cycle Assessment Springer*, 23(3), 556–568.
- Eynard, U. et al. (2018). Social risk in raw materials extraction: a macro-scale assessment. *Social LCA*, p. 221.
- Feschet, P., et al. (2013). Social impact assessment in LCA using the Preston pathway. *International Journal of Life Cycle Assessment*, 18(2), 490–503. <https://doi.org/10.1007/s11367-012-0490-z>.
- Fava, J., et al. (1993). A conceptual framework for life-cycle impact assessment; Workshop Report; February 1–7; 1992, Sandestin, Florida.
- Foolmaun, R. K., & Ramjeeawon, T. (2013). Comparative life cycle assessment and social life cycle assessment of used polyethylene terephthalate (PET) bottles in Mauritius. *The International Journal of Life Cycle Assessment*, 18(1), 155–171.
- Güereca, F. E. (2018). Social life cycle assessment of rural cassava starch factories in Cauca-Columbia in the post-conflict. *Social LCA*, p. 150.
- Hunkeler, D. (2006). Societal LCA methodology and case study. *The International Journal of Life Cycle Assessment Ecomed*, 11(6), 371–382. <https://doi.org/10.1065/lca2006.08.261>.
- Hutchins, M. J., & Sutherland, J. W. (2008). An exploration of measures of social sustainability and their application to supply chain decisions. *Journal of Cleaner Production. Elsevier*, 16(15), 1688–1698.
- ISO (2006) *Life Cycle Assessment: Principles and Framework, Environmental Management*. Retrieved April 1, 2018, from <https://www.iso.org/standard/37456.html?browse=tc>.
- Jørgensen, A. et al. (2008). Methodologies for social life cycle assessment. *International Journal of Life Cycle Assessment*, 96–103. <http://dx.doi.org/10.1065/lca2007.11.367>.
- Koninklijke Philips, N. V. (2015). *Philips annual report 2015*. Retrieved April 21, 2018, from [http://www.philips.com/corporate/resources/annualresults/2015/PhilipsFullAnnualReport2015\\_English.pdf](http://www.philips.com/corporate/resources/annualresults/2015/PhilipsFullAnnualReport2015_English.pdf).

- Labuschagne, C., & Brent, A. C. (2006). Social indicators for sustainable project and technology life cycle management in the process industry. *International Journal of Life Cycle Assessment*, 3–15. <https://doi.org/10.1065/lca2006.01.233>.
- Mancini, L., & Sala, S. (2018). *Social impact assessment in the mining sector: Review and comparison of indicators frameworks*. *Resources Policy*. Elsevier.
- Norris, C. B., Aulisio, D., & Norris, G. A. (2012). Working with the social hotspots database—methodology and findings from 7 social scoping assessments. *Leveraging Technology for a Sustainable World*. Springer, pp. 581–586.
- Norris, G. A. (2006). Social impacts in product life cycles—Towards life cycle attribute assessment. *The International Journal of Life Cycle Assessment Springer*, 11(1), 97–104.
- Parent, J., Cucuzzella, C., & Revéret, J.-P. (2010). Impact assessment in SLCA: sorting the sLCIA methods according to their outcomes. *The International Journal of Life Cycle Assessment Springer*, 15(2), 164–171.
- Petti, L., Ugaya, C. M. L., & Di Cesare, S. (2014). Systematic review of social-life cycle assessment (S-LCA) case studies. *Social LCA in progress*. *FruiTrop, Montpellier*.
- Pörtl, M., & Spiegel, B. (2014). Arbitration under International Social Security Instruments. *Intertax*, 42(3), 194–201.
- UNEP-SETAC. (2013). The methodological sheets for sub—Categories in social life cycle assessment (S-LCA). *Life cycle initiative, UNEP-SETAC*. Retrieved May, 2, p. 150.
- Villegas, J. D. et al. (2018). Social performance evaluation of an artisanal apparel brand in Peru using Social LCA. *Social LCA*, p. 105.
- Weidema, B. P. (2006). Social impact categories, indicators, characterisation and damage modelling. In *Presentation for the 29th Swiss LCA Discussion Forum*. <http://lca-net.com/p/1021>.
- Werker, J., Wulf, C., & Zapp, P. (2018). Pathways to S-LCA Interpretation—where to start. *Social LCA*, p. 155.

# Chapter 8

## Life Cycle Inventory Management



You Wu and Daizhong Su

**Abstract** A novel approach for converting ecoinvent data format (i.e. EcoSpold) to SQL format is developed to achieve life cycle impact (LCI) inventory data management and to serve web based applications. The approach is demonstrated by employing the data extraction programming script and applying the extracted data values and information in an SQL database management client. A XML parsing library is used to implement the automated EcoSpold files search and extraction function, which is invoked by a Python script. A Java based graphical user interface GUI application is also developed, in order to help users to select the feasible LCI datasets and achieve automated data file import into the life cycle assessment (LCA) software, in order to conduct LCA calculations.

**Keywords** Life cycle assessment · Life cycle inventory · Life cycle inventory management · Life cycle inventory data bridging tool · EcoSpold

### 8.1 Introduction

Life cycle assessment (LCA) research has a history of more than two decades, and the life cycle inventory databases have been strongly improved regarding the number of processes, the geographical representativeness and the scale of datasets, but data quality is still one of the most important problems to be resolved. As any LCA can only deliver a snapshot of the status performance at the time of analysis, it is hard for even the best ones to provide up-to-date data at any given time; consequently, many of the life cycle data available and used in the assessments are out-dated (Geibler et al. 2013). Another problem is that the life cycle inventory (LCI) data may have been estimated using differing assumptions, data sources and system boundaries, assumptions which make it difficult to compare results from different LCA studies.

---

Y. Wu (✉) · D. Su

School of Architecture, Design and the Built Environment, Advanced Design and Manufacturing Engineering Centre, Nottingham Trent University, Nottingham, UK  
e-mail: [you.wu@ntu.ac.uk](mailto:you.wu@ntu.ac.uk)

D. Su

e-mail: [daizhong.su@ntu.ac.uk](mailto:daizhong.su@ntu.ac.uk)

© Springer Nature Switzerland AG 2020  
D. Su (ed.), *Sustainable Product Development*,  
[https://doi.org/10.1007/978-3-030-39149-2\\_8](https://doi.org/10.1007/978-3-030-39149-2_8)

Product specific primary data are often missing, and general data from life cycle inventory databases, e.g. ecoinvent (see Chap. 3) has to be used instead. Therefore, a flexible and powerful tool is required to implement the retrieve and delivery for the LCI datasets.

The existing LCA software, e.g. SimaPro and GaBi (see Chap. 4) are well-developed in theoretical and practical levels, but they heavily rely on the desktop-based software. The main reason is that the existing LCI databases are designed and created for the desktop software environment, particularly the commercial LCI database, ecoinvent, provides the custom XML format based datasets, known as EcoSpold. This is not easy for flexible data management to be implemented within the web-based operating environment.

In order to sever the web-based product environmental performance evaluation system, the LCI database is required to convert into SQL (Structured Query Language). SQL are designed to allow the user to have full manipulation capability of the data in the relational database and to play an intermediate role between computer programs and the relational database. Furthermore, SQL is a basic way to interact with a relational database.

The ecoinvent database is selected to demonstrate the proposed functions. As it is the widely accepted LCI database by the LCA software, in order to implement LCA calculations between desktop LCA software and other tools, there is a need to bridge LCA datasets (e.g. ecoinvent datasets) among these tools. This chapter will introduce the approach to implement the data format conversion, an LCI data management framework and the development of a GUI application executing data bridging functions. The data bridging functions include performing automatic import for compatible LCI datasets into LCA software, and export selected LCI datasets from central SQL database and apply into LCA software, which are explained in Sect. 8.3.1 and illustrated in Fig. 8.8.

## 8.2 Converting Ecoinvent Database into SQL Database

The following section addresses a novel approach to convert EcoSpold into SQL database management tool. The conversion will utilise a script implementing the EcoSpold data parsing and extraction, and importing the extracted data into a SQL database management tool. The whole process of this approach is illustrated in Fig. 8.1.

**Fig. 8.1** The conversion process from EcoSpold to SQL

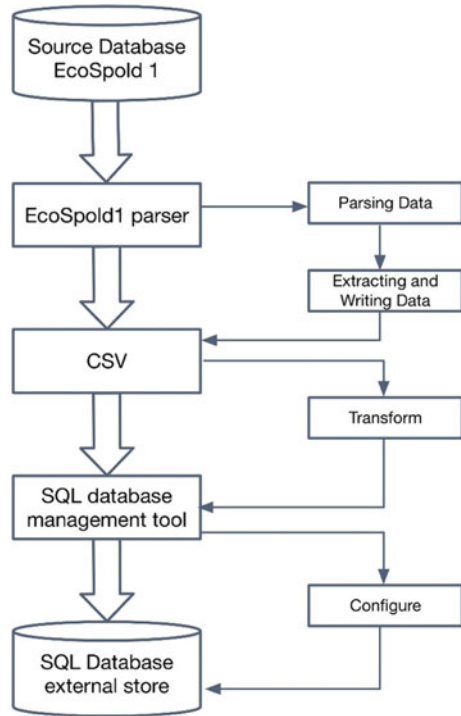

### 8.2.1 EcoSpold Parsing

Inecoinvent, each data file has the same data structure, which records the information and values of processes and substances. For a single EcoSpold file, there are three main data components, which are presented in Fig. 8.2, and are described as follows:

- Dataset: contains initial information about one system process.
- Meta information: contains information about the process, modelling assumptions, validation details and administration.
- Flow data: contains information about inputs and outputs flows and information about allocation.

In order to extract all the values of each data element in each file, it is required parse each EcoSpold file. As the EcoSpold is compiled by XML language (see discussion in Sects. 3.2.1 and 6.2.1), the method for parsing XML file is applied.

In order to obtain the information and values contained in the XML file, the XML file is required to be handled by software that can recognises the data structure, and provide functions to implement other data format declarations. Two techniques are



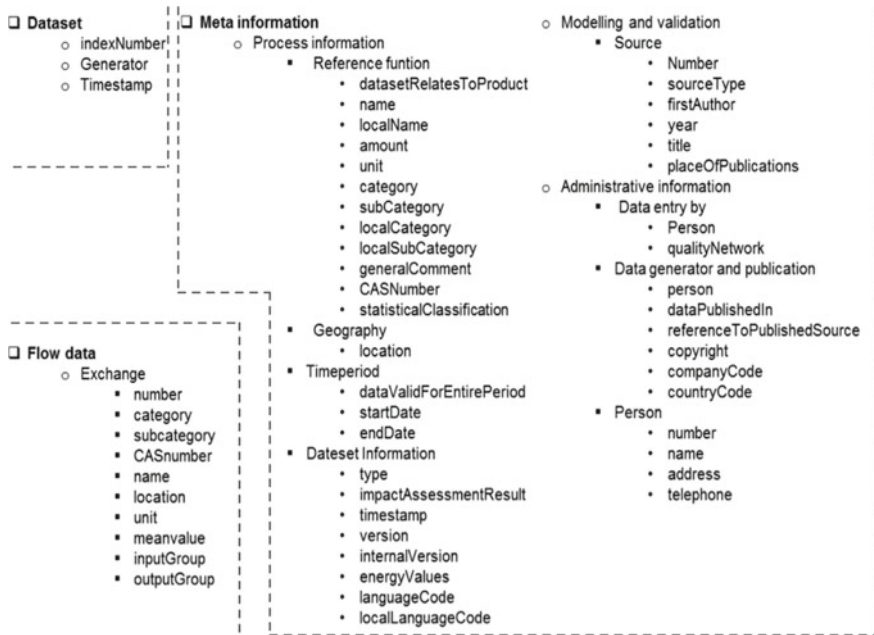

Fig. 8.2 EcoSpold data elements (Hischier et al. 2010)

mainly applied in order to implement XML processing: Event based method and Tree-based method.

The event-based method is a stream-oriented technique that supports the user to access the XML contents sequentially. Simple API for XML (§SAX) is the standard developed in different languages (e.g. Python, Java) (SAX n.d.), which handles XML file without constructing computer memory representation. Moreover, the user can define a set of call-back methods while a particular event occurs during the parsing. The Document Object Model (DOM) is a type of tree-based technique that supports users to generate a memory representation of an XML file (Consortium 2004). With DOM, every element of the XML file can be navigated and accessed. Therefore, SAX is suitable for straightforward XML parsing without considering the consumption of the computer resources, and DOM is suitable for complex XML parsing, for example, multiple extracting different data types in different XML files.

In the case of parsing EcoSpold files, SAX approach is used because all the data types that are required to parse and extract are the same. Python language is applied to implement the EcoSpold parsing and extracting. Xml.sax is a standard library in

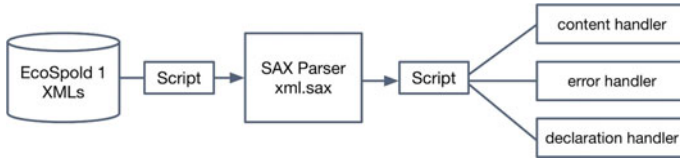

Fig. 8.3 The process for parsing EcoSpold

```

<metaInformation>
  <processInformation>
    <referenceFunction name="packaging glass, white, at plant" localName="Verpackungsglas, weiss, ab Werk"
      infrastructureProcess="false" unit="kg" category="glass" subCategory="packaging" localCategory="Glas"
      localSubCategory="Verpackungsglas" amount="1" includedProcesses="This module includes the material and energy
      efforts for: preparation of the glass melt, melting furnace, feeder, container forming, cooling down, packaging.
      Transports for the input materials are included as well as direct emissions to air, waste water and waste."
      generalComment="A production site with a sorting capacity of 100 kt per year and a total life span of 50 a is
      assumed." infrastructureIncluded="true" datasetRelatesToProduct="true"/>
    <geography location="DE" text="average German situation, based on an industry survey"/>
    <technology text="Mix of really used technologies in Germany"/>
  
```

Fig. 8.4 Meta information of 00827.EcoSpold

Python, which is designed to implement SAX method for XML file parsing. The process for implementation of EcoSpold parsing is illustrated in Fig. 8.3.

As Fig. 8.3 shows, in order to implement the xml.sax, Python script files are used, which was compiled in order to handle three functions, as follows:

- Content handler: define the extracted data name, category and type.
- Error handler: define warning information and responses when the parser detects errors.
- Declaration handler: declare the path of source data, and path for storing extracted data.

In order to demonstrate the extracting process, a EcoSpold file (i.e. 00827.EcoSpold) is presented in Fig. 8.4, which shows ‘MetaInformation’ of the EcoSpold file. As Fig. 8.4 shows, there are some data elements, including ‘name’, ‘localName’, ‘infrastructureProcess’, ‘unit’, ‘category’, ‘subCategory’, ‘localCategory’, ‘localSubcategory’, ‘amount’, ‘includeProcessess’, ‘generalComment’, ‘infrastructureIncluded’, ‘datasetRelatesToProduct’, ‘geography’, and ‘technology’.

These structured data elements are contained in each EcoSpold file, and in order to extract these data, a Python script is compiled, to apply the xml.sax library and extract the required data elements. The primary function of this script is to expand each data element of the file with different conditional statements depending on the attributes of the date element. For each item, the script searches for attributes and namespaces declarations. The data element is restructured to create a sequence of attribute element with value moved to a new output form. The function works recursively to transform data elements with nested children.

id	category	subcategory	localname	meanvalue	unit	
826	glass	packaging	packaging glass, white, at plant	038902-17-3	kg	1 CI
1381	natural gas	power plants	electricity, natural gas, at power plant	068333-17-3	kWh	1 IT
827	glass	packaging	packaging glass, white, at plant	065421-17-3	kg	1 D
828	glass	packaging	packaging glass, white, at plant	098711-17-3	kg	1 RI
829	glass	packaging	packaging glass, white, at regional storage	023891-17-3	kg	1 CI
831	hard coal	fuels	hard coal briquettes, at plant	044597-17-4	MJ	1 RI

**Fig. 8.5** An example showing 00827.EcoSpold extracted information storing in CSV

### 8.2.2 Transforming the Extracted Data into CSV File

In the script implementation process, EcoSpold file is analysed in order to extract knowledge required for the subsequent processes. Information and values regarding data element types are extracted from the highly-structured EcoSpold. Moreover, this process can automatically write the extracted data into a rationale form. In this step, Comma-Separated Values (CSV) form is applied (see Fig. 8.5), as it is a common data exchange format that is widely accepted by database management tool. Therefore, this process is required in order to identify the complex and simple types used in the specified CSV file. The data extraction process is involved in detecting basic types such as integers, decimal, bit-strings and others which can be mapped to a lower signed/unsigned CSV form.

### 8.2.3 Importing the CSV into Database Management Tool

Once all of the EcoSpold files are extracted into the CSV file, the CSV file is needed to import into a SQL database management tool. Navicat Premium (PremiumSoft n.d.) is applied, which is a powerful database management tool as MySQL, and PostgreSQL. It is a straightforward step to import the CSV file into the database management tool. As the Fig. 8.6 shows, firstly create a new database, then click 'tables' within the new database, and select the 'data format' as CSV.

Once the CSV file imported into the Navicat, 32 tables extracted from ecoinvent can be found, as Fig. 8.7 shows. The 'tbl\_processes' is the core table as it contains the figures and information regarding the flows and the processes. The relationship between the flows and processes are defined in 'tbl\_categories' table, of which 'f\_parent\_category' column shows 'null' are flows, and the rest columns are processes.

Until this step, the ecoinvent has been successfully converted and imported into a SQL database management software. In order to use this SQL supported LCI database in other web applications, it is only required to configure the connection protocol between this database software and application servers, which is not reported in this chapter.

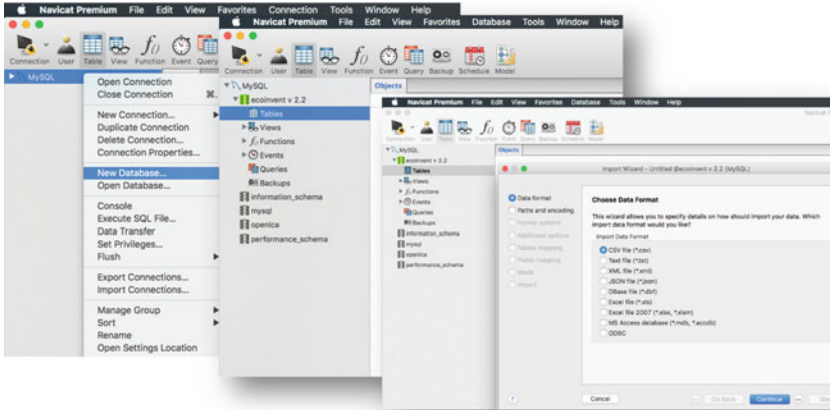

Fig. 8.6 Import the CSV file into the database management software

### 8.3 Development of the LCI Data Bridging Tool

#### 8.3.1 Overview of the Tool

In order to export the SQL formatted LCI databases to serve other web applications, an LCI data management GUI (Graphical User Interface) is proposed to achieve the data bridging functions. Except for the LCI datasets from the ecoinvent database, some product lifecycle data provided by the governmental departments or business associations can also be stored in the database, for example, UK statistics on waste (DEFRA 2015) is a spreadsheet based database that provides the waste statistics in the UK; one of the statistical categories is regarding the various packaging wastes, which is useful for the recycling scenario analysis for the LCA. This proposed solution would be useful for users to retrieve and investigate the feasible LCI data when their required data is missing in the ecoinvent data. These stored LCI data need to convert into feasible data formats, in order to apply these stored LCI data in professional LCA software packages and applications. Hence, an LCI data management GUI is proposed to develop for users to select the required LCI data from the SQL database and export the data to required formats.

On the other hand, users usually use these exported LCI data in the main LCA software and applications. Therefore, an investigation regarding the accepted data import formats of main LCA tools is conducted. The investigation results are presented in Table 8.1, which shows that EcoSpold is the data format supported by all the LCA software.

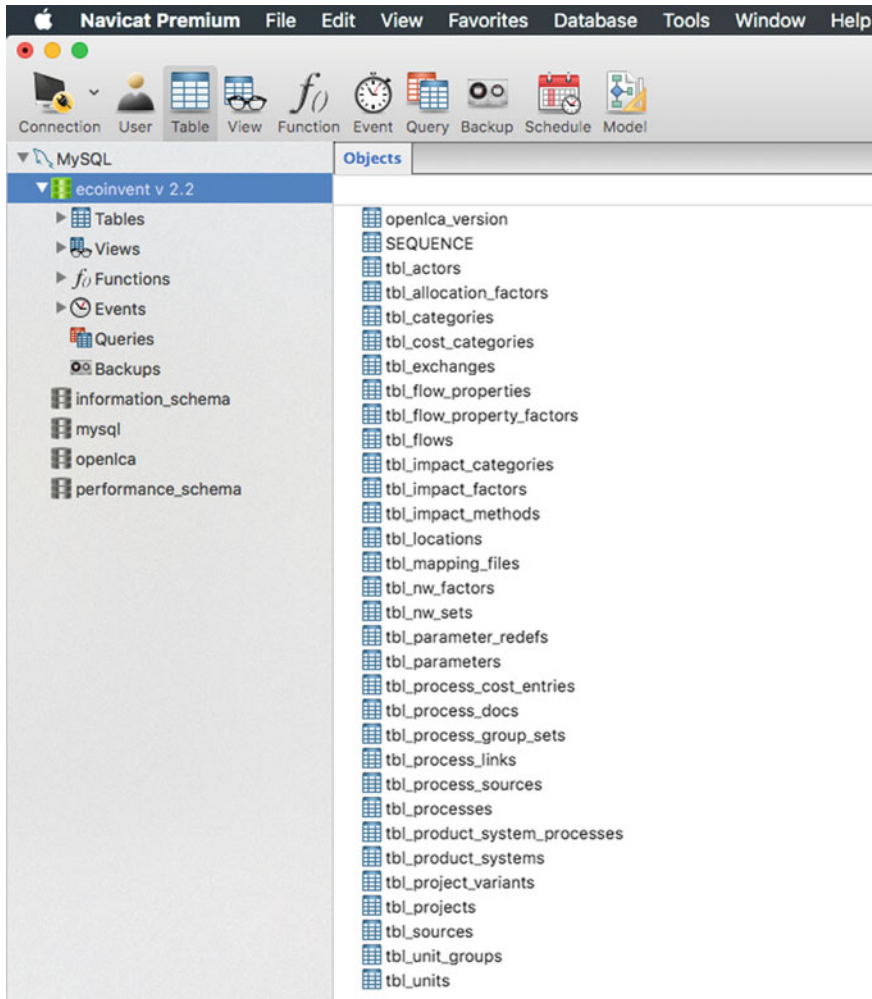

**Fig. 8.7** A screenshot of Navicat Premium showing ecoinvent SQL tables

**Table 8.1** Import and export formats accepted by LCA software

LCA software	Import format		Export format	
<i>SimaPro 7.3</i>	CSV EcoSpold v1	SimaPro	CSV EXCEL	TXT EcoSpold v1
<i>Gabi 6</i>	GBX GPR file	ILCD EcoSpold v1	GBX GPR file ILCD	EPD EcoSpold v1
<i>OpenLCA 1.5</i>	EcoSpold v1 & v2 Excel ILCD	SimaPro CSV ILCD ZOLCA	EcoSpold v2 Excel ILCD	EcoSpold JSON-LD
<i>Umberto</i>	Umberto project file		EXCEL, CSV	

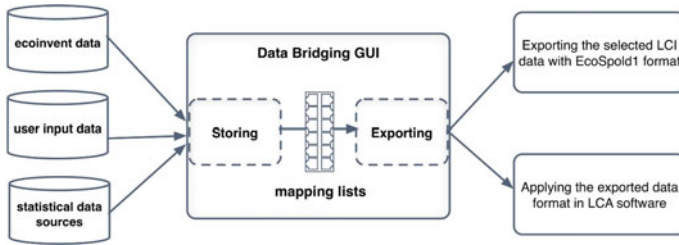

**Fig. 8.8** A framework demonstrating the data bridging functions and data flow

Based on the investigations, the data flow for the GUI application implementing LCI data bridging function is depicted in Fig. 8.8. The core functions of the data bridging GUI are described as follows:

- Export the selected LCI data in an EcoSpold format file.
- Automatically apply the exported data in the LCA software tool.

As the exported data sets are formed in EcoSpold format, there is a mapping process forming the selected data elements and other relevant data sets. The mapping process is designed for users to define and select LCI data because the stored LCI data maybe need an update or modify to meet the requirements of users’ use scenarios. There are four tasks involved in this mapping process:

- The data elements that are compulsory for LCA calculation will be selected by users and invoked from the database.
- The data information that is not compulsory for LCA calculation will not be displayed or set a default value in the exported data, in order to control the size of exported data format files. For example, the ‘general comment’ within the ‘reference information’ will not be able to export and only be viewed in the GUI interfaces.
- The data sets that need to be input or updated by users will be achieved in the GUI interfaces. For example, ‘localName’ is the relevant field in the EcoSpold 1 file. It is the local name of product and needs to be input by the user in the GUI interfaces.
- The background information of exported data sets will be automatically defined by the GUI in the backend, for example, ‘Today’s date’ indicates the date of the data exported from the database.

A table demonstrating these four type data categories within an exported EcoSpold template is presented in Appendix 8.1, which clearly shows the contents of each data category and their data attributes.

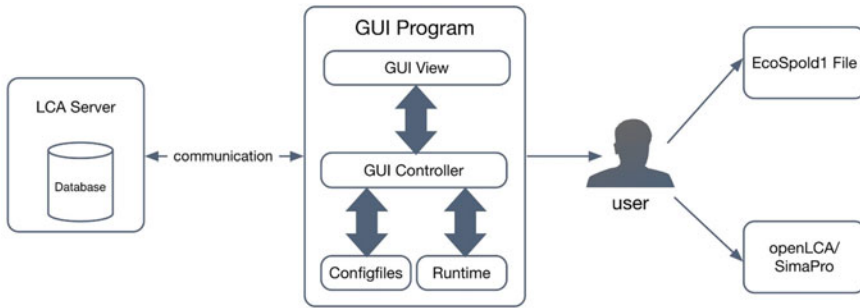

**Fig. 8.9** The LCI data bridging GUI architecture

### 8.3.2 Development of the GUI Components

Based on the above investigations, the data sets as required from the server and database is implemented by a GUI application. This GUI application is a Java package, and consists of a number of Java graphical components corresponding to LCI data mapping, communication and exporting processes. This involves a GUI communicate with server and database over the Internet. This GUI is developed with Java Swing package in Eclipse development platform. The architecture of the LCI data bridging GUI is presented in Fig. 8.9.

There are four main components in this GUI program, which are described as follows:

- The configuration files are written in XML, containing runtime assertions, settings of view components, communication message between the GUI controller and LCA server, and database.
- Communication protocols are two-way message delivering communication between LCA server and GUI controller, which are also implemented by the GUI program package. Each event of user requesting LCI data from the server is supported with the communication pattern, implemented both in the server side and GUI controller.
- The GUI controller is the central component of this application as it coordinates with all other components of the GUI program:
  - The controller reads the configuration file, which contains the specification of retrieving and inputting LCI data, and use it as guidance for mapping required LCI data elements, and generating EcoSpold files.
  - The controller communicates with the GUI view to support the interactions with users. It transmits data to the GUI view, and delivers users' commands and input-data to the server side.

- The controller also coordinates a checking module in runtime that record runtime data about the Java program through this application. Users can use the configuration file modify the specific requirement, for example, what type of LCI data are visible/hidden.
- The runtime contains all the required package and libraries for running this GUI application.

The connection is established through communication protocol declared in the GUI configure files, and the data bridging is performed to retrieve the requested data. Once the connection is established, the data is retrieved and stored in the local path where the GUI is being executed. The data retrieved and stored in the local is added with the user input from the GUI and created as an EcoSpold file. Once it meets the requirements of the specified standards (i.e. EcoSpold data structure and standards), it can be imported to the LCA software, and the LCA calculation is triggered. Based on the review results offered in Sect. 8.3.1, openLCA software supports the most LCI datasets within those reviewed LCA software, therefore, openLCA is used to demonstrate the automagical LCA calculation through the implementation of Data Bridging GUI. A screenshot of the GUI prototype is shown in Fig. 8.10.

This GUI application is a standalone package, after the installation of GUI, users can search the LCI data related to a product through searching the product’s basic

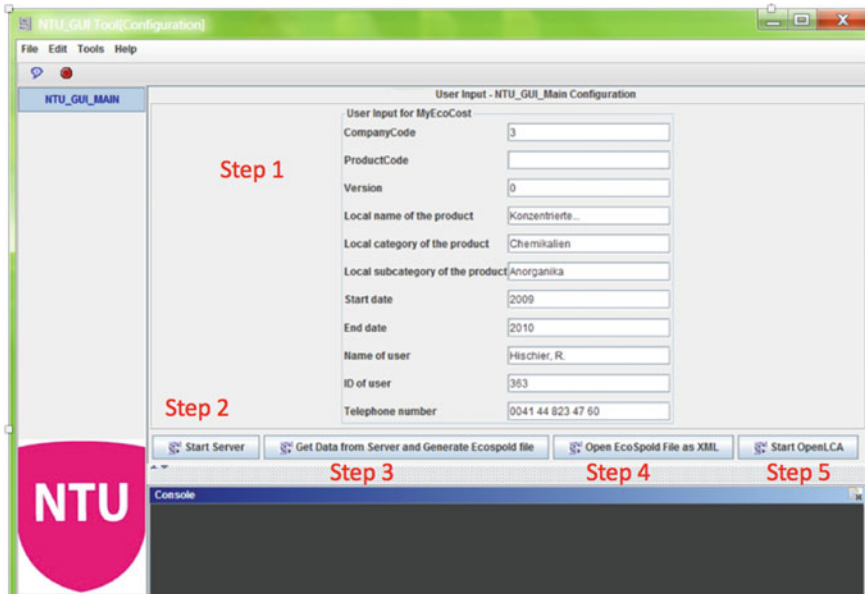

Fig. 8.10 Interface of the GUI application



information, e.g. product name, product category, and Invoice (see step 1 Fig. 8.10). Once users confirm the requested LCI data, they need trigger the business server by clicking the ‘Start Server’ (see step 2 Fig. 8.10), and send the LCI request by pushing ‘Get Data from Server and Generated EcoSpold file’ (see step 3 Fig. 8.10). Then the user requested LCI data sets are automatically stored on the local computer in the form of EcoSpold format file, which is readable by the normal text editor (see step 4 in Fig. 8.10). This file describes the processes and resources involved in manufacturing this product. Moreover, this user custom defined EcoSpold file is accepted by the openLCA and SimaPro LCA software, and users can import this file into LCA software to conduct an independent environmental performance assessment on the product (see step 5 Fig. 8.10).

## 8.4 Conclusions

In order to serve LCI database into web-based applications, the ecoinvent database is applied to convert the data into SQL format, which is a key novelty of this chapter as there is no study introducing the methods and techniques to process EcoSpold files. A framework for implementation of the conversion process is developed, which involves the EcoSpold files parsing and extracting, and storing in a CSV file. xml.sax library is used to implement the automated EcoSpold file search, which is invoked by a Python script. The extracted LCI datasets are successfully imported into the SQL database management software, which demonstrates the conversion method and used technologies are useful for processing EcoSpold files.

As a novel feature in this chapter, a Java based GUI application implementing LCI data bridging function is also developed and introduced. The process of generating EcoSpold file is carried out by first acquiring the LCI data records. Then, other missing data in the database are supplied via user input in the developed GUI. By merging the two streams of data inputs, the EcoSpold is generated and ready for importing into openLCA. As a result, the aggregated LCI data is transferred into LCA tools, in order to conduct life cycle analysis of the corresponding products.

## Appendix

Appendix 8.1 Mapping table for data-bridging GUI application to generate EcoSpold file.

EcoSpold		Type	Compulsory in LCA subcalculation	Programme in background	Input displayed on GUI
Dataset	Reference function	number	ProductCode	{as file name}	
		Generator		[myEcoCost data bridging v1]	
		Timestamp		[Today's date]	
		datasetRelatesToProduct	Boolean		
		localName	Text	productName	local name of the product
	Process information	amount	Number(Real)	ProductAmount	
		unit	Text	ProductAmountUnit	
		category	Text	Category	
		subCategory	Text	SubCategory	
		localSubCategory	Text		Local category of the product
Meta information	GeneralComment	Text	GeneralComment		
	CASNumber	Text	CASNumber	Local subcategory of the product	
	statisticalClassification	String	StatisticalClassification		
	number	Number(Long)	Location		
	dateTimeForTimePeriod	Boolean			
	startDate	Date	startDate	Start date	
	endDate	Date	endDate	End date	
	Modelling and validation	type	Integer		
		ImpactAssessmentResult	Boolean		
		timestamp	DateTime		
version		Decimal	Version		
internalVersion		Decimal			
energyValues		Byte			
languageCode		Text			
localLanguageCode		Text			
number		Integer			
sourceType		Byte			
Administrative information	firstAuthor	Text	firstAuthor	Name of user	
	year	Integer	[2015]		
	title	Text	[myEcoCost]		
	placeOfPublications	Text			
	person	Person			
	qualityNetwork	Integer			
	person	Integer			
	dataSubmittedIn	Byte			
	referenceToJobInSource	Integer			
	copyright	Boolean			
Flow data	companyCode	Text	CompanyCode		
	countryCode	Text	Location		
	number	Integer			
	name	Text	CompanyAddress	Telephone number	
	address	Text			
	telephone	Text			
	number	Integer	FlowID		
	category	Text	Category EFD		
	subCategory	Text	SubCategory EFD		
	CASNumber	String	CASNumber EFD		
Exchange	name	Text	FlowName EFD		
	location	Text	Location		
	unit	Text	FlowUnit EFD		
	meanValue	Single	FlowValue		
	GeneralComment	Text			
Flow data	inputGroup	Text			
	outputGroup	Text			
	number	Number			
	number	Number			
	number	Number			

## Legends for the Mapping Table

- Green columns represent compulsory data elements for the LCA calculations.
- Orange columns represent data types proceeded in the back end of the GUI.
- Cells with square brackets indicate the value will be a constant number. For instance, '[2]' represent the value will be fixed to 2.
- A cell of a pair of round brackets, the activity is proceeded via code and not displayed to the user. For example, '(Today's date)' indicates today's date will be generated automatically for the value.
- Cells without any bracket are required to input by users, which are indicated in the right section coloured by dark blue. For instance, 'localName' is the relevant field in the EcoSpold file. It is the local name of product and needs to be input by user in the client interfaces.

## References

- Consortium, W. W. W. (2004). *Document object model (DOM) level 3 core specification*.
- DEFRA. (2015). ENV23-UK statistics on waste. Retrieved June 5, 2016, from <https://www.gov.uk/government/statistical-data-sets/env23-uk-waste-data-and-management>.
- Von Geibler, J. et al. (2013). Forming the Nucleus of a Novel Ecological Accounting System: The myEcoCost Approach. *Key Engineering Materials*, 572, 78–83.
- Hischier, R. et al. (2010). *Implementation of life cycle impact assessment methods data, v2.2 (2010)* (Ecoinvent Rep. No. 3). Retrieved April 20, 2016, from [https://www.ecoinvent.org/files/201007\\_hischier\\_weidema\\_implementation\\_of\\_lcia\\_methods.pdf](https://www.ecoinvent.org/files/201007_hischier_weidema_implementation_of_lcia_methods.pdf).
- PremiumSoft: About Us, PremiumSoft Company History and Contact Information. Navicat. Retrieved April 26, 2017, from <https://www.navicat.com/products/navicat-premium>.
- SAX. Retrieved from <http://sax.sourceforge.net/>.

# Chapter 9

## Genetic Algorithm for Sustainable Product Design Optimisation



Zhongming Ren and Daizhong Su

**Abstract** This chapter starts with the introduction of genetic algorithm (GA), including the definition of the GA optimisation, the development history and methodology of the algorithm, and its advantages and limitations, followed by the introduction of the GA tool embedded in software package MATLAB. And then the approach of sustainable product design optimisation using GA is presented, including brief information of product life cycle analysis (LCA) and life cycle impact assessment (LCIA) method/tool selection, a three-tier structure for product LCA, and the sustainable product design optimisation procedure. The approach is demonstrated with a case study using an industrial gearbox.

**Keywords** Optimisation · Genetic algorithm · Optimisation software tools · Life cycle analysis · Life cycle impact assessment · Gearbox

### 9.1 Introduction to Genetic Algorithm

Before introducing the Genetic Algorithm (GA) Optimisation, it is necessary to clarify what are the GA and the optimisation separately at the beginning. The word ‘optimisation’ are defined as ‘the act of making something as good as possible’ and ‘the action of making the best or most effective use of a situation or resource’ in both Cambridge Dictionary (2018) and Oxford Dictionary (2018). Specifically in engineering science, it is a process to seek for the best solution of a specified problem in an assigned scope.

---

Z. Ren (✉)

School of Art and Design, Shanghai University of Engineering Science, No. 333 Longteng Road, Songjiang 201620 Shanghai, China  
e-mail: [zren@sues.edu.cn](mailto:zren@sues.edu.cn)

Shanghai Institute of Design and Innovation, Tongji University, No. 281 Fuxin Road, Yangpu 200092 Shanghai, China

D. Su

School of Architecture Design and the Built Environment, Advanced Design and Manufacturing Engineering Centre, Nottingham Trent University, Nottingham, UK  
e-mail: [daizhong.su@ntu.ac.uk](mailto:daizhong.su@ntu.ac.uk)

The genetic algorithm simulates the biological evolution process, which was proposed by Goldberg (1989), to select the best individual in a species through a natural selection like procedure. In another way to say, it is to seek for the best solution in a specific scope according to the principle of the biological evolution. The objective is correspond to that of the optimisation.

The genetic algorithm has been widely researched and implemented in the field of optimisation in a variety of disciplines. Geweda et al. (2017) applied the GA for improvement of vehicle ride comfort. Lu and Ye (2017) found the optimum design factor for the stability of domes. Choi et al. (2017) and his colleagues confirmed that an optimal schedule of haemodialysis generated by applying GA can be more efficient than traditional one. A multi-objective optimisation of reheating furnace operations was conducted for improving heating accuracy, temperature uniformity, and fuel consumption by Hu et al. (2017). In the field of mechanics, West et al. (2016) developed a genetic algorithm to solve the problem of dynamic modelling and estimated design parameter of a seven degree of freedom robotic manipulator. It is clear to see that the genetic algorithm is a powerful and capable tool for solving optimisation problems in diverse disciplines and fields.

Why is it be implemented so widely for solving optimisation problem in these days? The answer is that it has multiple advantages than traditional algorithms. This will be explained in details in the following sub-sections.

### ***9.1.1 The Methodology***

Since 1960s, there has been an increasing interest in imitating living beings to solve optimisation problems, because of the difficulty and complexity of them, such as multi-objective and multi-disciplinary questions, which are quite hard to solve by traditional algorithms. The Genetic Algorithm, as the most widely applied type of evolutionary algorithm using stochastic optimisation methods, imitates Darwin's theory of biological evolution, which is more effective and has better performance than traditional ones (Gen and Cheng 1997).

It is necessary to introduce some of the knowledge of biological evolution before explanation of the methodology of the GA. In the first place, we need to understand some terms as listed below (Oxford Dictionaries 2018):

*Population:* A community of animals, plants, or humans among whose members interbreeding occurs.

*Individual:* a single member in the population.

*Chromosome:* A threadlike structure of nucleic acids and protein found in the nucleus of most living cells, carrying genetic information in the form of genes.

*Gene:* a unit of heredity which is transferred from a parent to offspring and is held to determine some characteristic of the offspring.

*Survival of the fittest:* The continued existence of organisms which are best adapted to their environment, with the extinction of others, as a concept in the Darwinian theory of evolution.

*Fitness:* An organism's ability to survive and reproduce in a particular environment.

*Selection:* A process in which environmental or genetic influences determine which types of organism thrive better than others, regarded as a factor in evolution.

*Crossover:* The recombination of genes from the last generation, parents, during the process of reproduction.

*Mutation:* The changing of the structure of a gene, resulting in a variant form that may be transmitted to subsequent generations, caused by the alteration of single base units in DNA, or the deletion, insertion, or rearrangement of larger sections of genes or chromosomes.

### 9.1.2 The Genetic Algorithm

The optimisation consists of three essential elements: objective, constraint and variable. The objective is a function indicating the fitness of the individual. It contains one or more variables, which are solutions we need to look for. The constraint sets up a boundary of the searching area of the optimal solutions. The genetic algorithm will search for the optimal solutions of the variables which obtains the best objective in the constraint condition.

In addition, other auxiliary parameters have to be set up, such as stop criteria, like the maximum number of generations. The algorithm stops when the number of generations reaches the limit value. Also, there are some other ones like time limit, fitness limit, etc.

In the beginning, the algorithm generates an initial generation randomly under the constraints, which is the first generation of population. Each individual in the population is called a chromosome. For simulating the biological evolution and easy to operate, the chromosome is usually encoded as a binary string, like 010000111....

The fitness of these individual is evaluated by an objective function, which is called evaluation or score function. The individual making the objective function reaching a limited value is defined as the one with best fitness in an optimisation problem. After evaluating the fitness of each individual, the best fitness ones are selected as parents to reproduce the next generation. This is so called 'survival of the fittest'.

The setting up of the fitness function always has the following rules:

- Non-negative number
- Reasonable and consistent
- Low calculating quantity, saving time.

There are two common patterns of reproduction: crossover and mutation. In the genetic algorithm, the *crossover* is the majority one for the reproduction as that in the biological universe. The mechanism of the crossover is to recombine the genome from

**Fig. 9.1** Three reproduction patterns

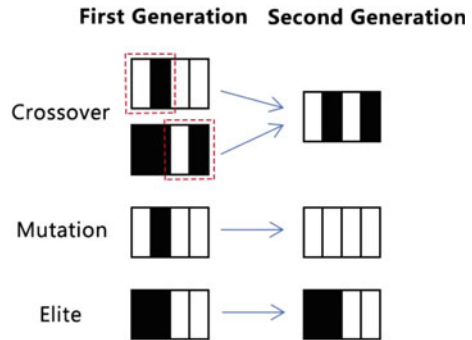

parents to form a new one. In another way to say, a child is reproduced by parents. It has characteristics from both of them. Which means its gene is recombined from a part of gene from father and a part of gene from mother. It may inherit mother's good one or father's bad one for survival in the environment or the opposite. Or good from both father and mother, which will be the best fitness one. The result is stochastic.

The *mutation* plays a special role in the GA. When the parents have not enough good genome to achieve the best fitness, it will introduce some fresh changes into the population to acquire more possibility and solutions. Under the condition of a mutation, the value of a random gene fragment will be changed.

In some specific problems, there is another pattern for generating the next generation, *Elite children*, which are individuals in the current generation with the best fitness. They survive to the next generation. It is a means of keeping high quality solution for the optimisation problems. Figure 9.1 shows the three patterns of generating the next generations.

The GA terminates when the individual with the best fitness, the optimal solution of the optimisation problem, has been found, or maximum numbers of generations have been produced. Then, the binary solution will be decoded.

### 9.1.3 Advantage and Limitation

Comparing with traditional algorithm, the GA has the following features and advantages:

- The GA starts to search for the solution from a population, string sets, but not single initial value. Large coverage is beneficial to obtain global optimal solution.
- It uses probabilistic transition rules, not deterministic rules.
- Do not need much mathematical knowledge about the optimisation problems. It can deal with any kind of objective functions or multi-objectives. Constraints can

be linear or nonlinear. It will search for solutions taking no account of specific inner operation of the problem (Goldberg 1989).

The GA has the following limitation:

- Parameters affect the performance and results of the GA, such as probability of crossover and mutation. In practice, these parameters need to be figured out case by case. There is no universal one.
- Convergence of the GA appears early sometimes due to inappropriate parameter setting. The result is a locally optimal solution.
- Non-standard encoding will cause inaccurate results.
- Time consuming and efficiency is lower than the traditional optimisation methods.

## 9.2 GA Tool Embedded in MATLAB

MATLAB is a mathematics toolkit software package developed by MathWorks (MATLAB nd.). The name combines matrix with laboratory. It is widely used for scientific calculation, data visualisation, modelling and simulation. Which provides a comprehensive solution for numerous fields such as scientific research, engineering, design, etc.

In the MATLAB, there is an optimization toolbox which has a genetic algorithm function module. The toolbox can be opened by tackling ‘optimtool’ command. Then a dialog box is displayed as shown in Fig. 9.2. The GA function can be triggered by selecting ‘ga-Genetic Algorithm’.

To start the GA calculation, the *Fitness function* and *Constraints function* have to be set up before the calculation. As mentioned before, the Fitness function is the one

Fig. 9.2 Optimisation tool in MATLAB (MATLAB nd.)

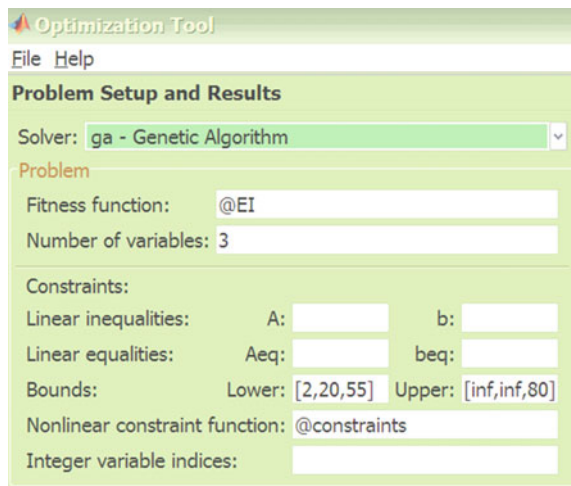



that evaluates the fitness of individuals in the population. The Constraints function lists the restriction of the solution set. Also, the lower and upper bounds need to be determined based on a particular application case.

The *stopping criteria* have to be set up to indicate when the calculation stops. The genetic algorithm uses the following stopping criteria in MATLAB (see Fig. 9.3):

- **Generations**—the algorithm stops when the number of generations reaches the value of **Generations**.
- **Time limit**—the algorithm stops after running for an amount of time in seconds equal to **Time limit**.
- **Fitness limit**—the algorithm stops when the value of the fitness function for the best point in the current population is less than or equal to **Fitness limit**.
- **Stall generations**—the algorithm stops when the weighted average change in the fitness function value over **Stall generations** is less than **Function tolerance**.
- **Stall time limit**—the algorithm stops if there is no improvement in the objective function during an interval of time in seconds equal to **Stall time limit**.
- **Function Tolerance**—the algorithm runs until the weighted average change in the fitness function value over **Stall generations** is less than **Function tolerance**.

**Fig. 9.3** Stopping criteria pane in the optimisation tool (MATLAB nd.)

Parameter	Use default	Specify
Generations:	<input checked="" type="radio"/> Use default: 100	<input type="radio"/> Specify: <input type="text"/>
Time limit:	<input checked="" type="radio"/> Use default: Inf	<input type="radio"/> Specify: <input type="text"/>
Fitness limit:	<input checked="" type="radio"/> Use default: -Inf	<input type="radio"/> Specify: <input type="text"/>
Stall generations:	<input checked="" type="radio"/> Use default: 50	<input type="radio"/> Specify: <input type="text"/>
Stall time limit:	<input checked="" type="radio"/> Use default: Inf	<input type="radio"/> Specify: <input type="text"/>
Function tolerance:	<input checked="" type="radio"/> Use default: 1e-6	<input type="radio"/> Specify: <input type="text"/>
Nonlinear constraint tolerance:	<input checked="" type="radio"/> Use default: 1e-6	<input type="radio"/> Specify: <input type="text"/>

- **Nonlinear constraint tolerance**—the **Nonlinear constraint tolerance** is not used as stopping criterion. It is used to determine the feasibility with respect to nonlinear constraints.

The calculation procedure of the optimisation using the GA tool in MATLAB is presented in Fig. 9.4. The optimisation starts from creating a random initial population. After calculating the fitness of individuals of the first generation, it judges whether the stopping criteria is met or not. If not, then it goes back to creating population of next generation. One route is to choose elites who has good enough fitness to survives. Another one is to produce children from parents who are selected.

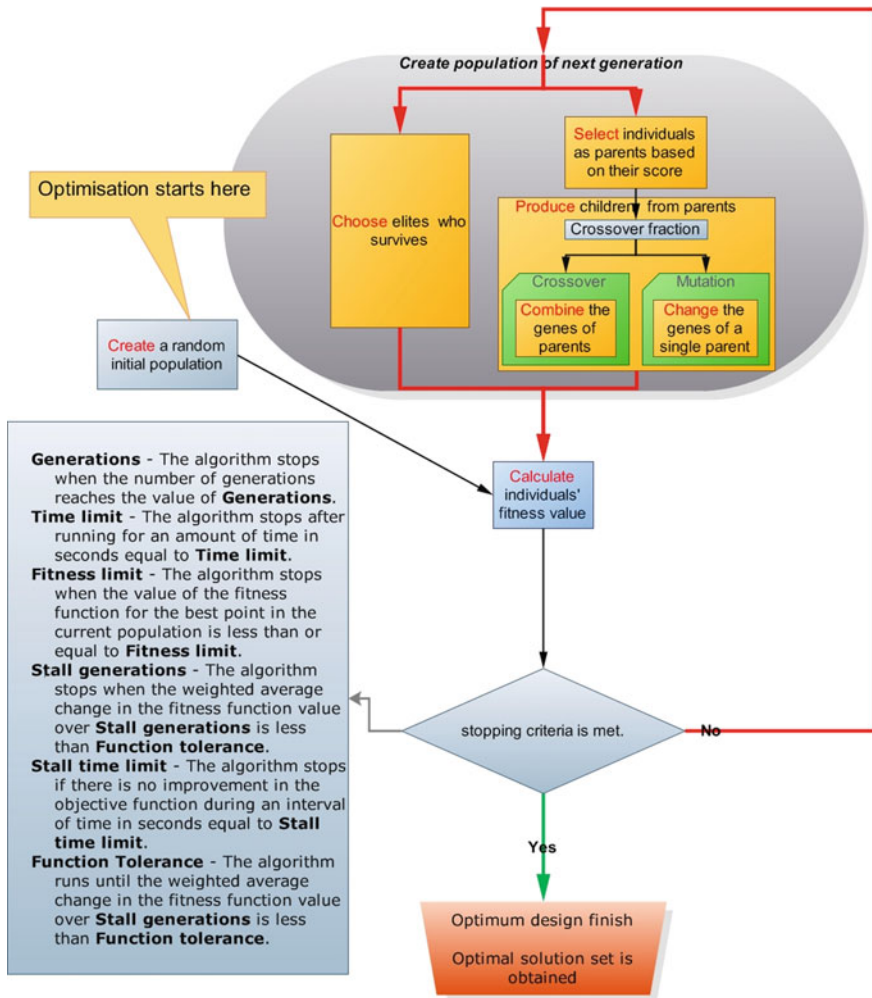

Fig. 9.4 Genetic algorithm flow chart in MATLAB

crossover route combines the genes of parents to reproduce a child. The mutation route changes the genes of a single parent. And then, the fitness of the second generation is assessed. As the number of generation increases, the individuals in the population get closer together and approach the limited point.

The process will not stop until one of these stopping criteria mentioned above is met. Depends on vary cases and conditions, the values of these criteria can be modified in the Stopping criteria pane as shown in the Fig. 9.4.

### 9.3 Sustainable Product Design Optimisation

In order to reduce the ecological impact of products, their impact throughout the whole product lifecycle has to be considered at the design stage, including material attraction, production, transportation, packaging, service life, recycling/reuse, and disposal. In order to effectively conduct the LCA for sustainable product design, a three-tiers approach is considers in this research. In addition, the assessment methods and software tool have to be considered.

**Three-tiers Approach to Assess Product's Ecological Impact** In this approach, a product is broken into three tiers: parts, subassembly and assembly. Within the production process of a product, related parts are assembled together to form a sub-assembly, and then all the sub-assemblies are assembled to form the final product (assembly). The product's ecological impact associated with the production process are relevant to the part and sub-assembly tiers, including impacts of materials used, manufacturing process, packaging, and transportation, as well as human labor and overhead eco-cost. In the assembly tier, the impact elements considered include transportation, packaging, product service life, design for disassembly, product reuse, recycling, and disposal.

**Selection of LCIA Methods and Software Tools** There are many LCIA methods and software tools. It is crucial to select a suitable LCIA method and software to conduct the sustainable product design. Chapters 3 and 4 provide the guidelines how to select the LCIA methods and software tools, which should be followed.

**Sustainable Product Design Optimisation Procedure** The procedure is shown in Fig. 9.5. When a new design is produced based on the product specification, the design are broke into three tiers firstly, including assembly, sub-assemblies and parts. The design parameters and necessary data of product are used as the inputs for the ecological impact calculation. The assessment of the product's ecological impact is then carried out by with appropriate LCIA software package, such as SimaPro, and LCIA method like RECIPE with consideration of human labour (Su and Ren 2011). After LCIA, results are analysed and presented to the user.

If the analysis results are satisfied with the requirement of sustainability, then the design finishes; otherwise, the design parameters, such as dimensions and materials, are optimised using genetic algorithm in MATLAB. The new design obtained after

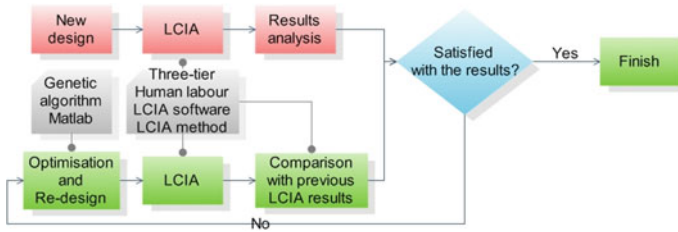

Fig. 9.5 Procedure of sustainable product design approach

the optimisation is then assessed with the life cycle impact assessment again and compared with the original design to find out whether the result is satisfied or not. If not, the design flow goes back to the optimisation stage again to re-design the product. If yes, the design is finished.

### 9.4 Case Study—Sustainable Design Optimisation of an Industrial Gearbox

This section takes an industrial gearbox as a case study of sustainable product design optimisation to illustrate how to implement a GA optimisation to reduce the environment impact of a design concept underpinned with the MATLAB.

#### 9.4.1 The Gearbox and Its Life Cycle Impact Assessment

A single stage industrial gearbox, shown in Fig. 9.6 (Gong et al. 1981), is taken as an example to illustrate how to implement design optimisation using GA. This type of gearbox has gained wide applications in industry for power transmission and speed reduction. Its technical parameters are as follows:

- Maximum power to be transmitted = 5 kW,
- Rotation speed of input shaft = 327 rpm, and
- Transmission ratio = 5
- Input shaft diameter = 30 mm,
- Output shaft diameter = 45 mm,
- Centre distance between the input and output shafts = 150 mm,
- Gearbox overall size (height × depth × width) = 320 mm × 195 mm × 430 mm.

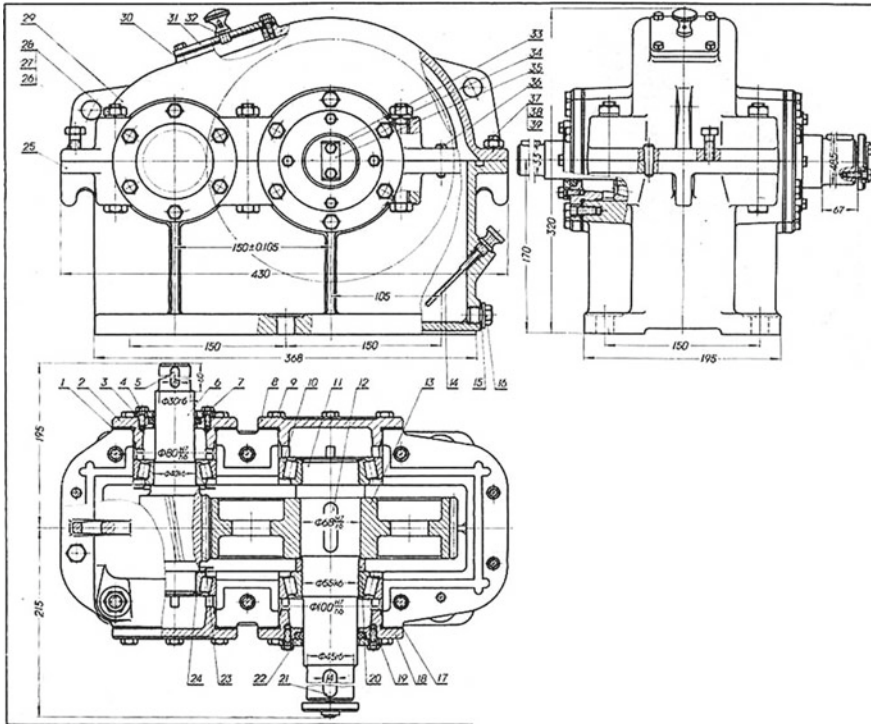

Fig. 9.6 Gearbox assembly drawing (Gong et al. 1981)

#### 9.4.1.1 Three-Tier Structure of the Gearbox

Following the procedure presented in Sect. 9.4 above, the gearbox design is considered in three tiers for the analysis:

- Parts, including one spur gear, one high speed shaft, one low speed shaft, two bearings for low speed shaft, two bearings for high speed shaft, five kinds of bolts, two kinds of nuts, one case base, one case cover, and four bearing end caps, etc.;
- Subassemblies, including high speed shaft assembly, low speed shaft assembly, case, bolts, and nuts; and
- Assembly, the gearbox.

Within the production process, related parts are assembled together to form a subassembly, and then all the subassemblies are assembled to form the final product, the gearbox. The three-tier approach provides a way for pre-processing the data to be inputted into LCIA software package.

### 9.4.1.2 LCIA Method/Tool Selection and Modelling with the Three-Tier Structure

The LCIA method ReCiPe is employed for LCIA of the gearbox, due to its capacity to conduct a full LCIA with the end-point impact assessment of human health, eco-systems and resources. Software tool SimaPro is selected because it is a comprehensive tool suitable to conduct a full LCIA, allows the user to add new data into its database, and has a better presentation means for comparison between two products which is suitable for optimisation (Ren and Su 2014). For further details, please see Sect. 4.5 of Chap. 4.

All the parts, sub-assemblies, and assembly within the tree-tier structure are presented in the product stages in SimaPro, as shown Fig. 9.7. According to the three-tier hierarchical structure, the gearbox is modelled using parameterised method in the SimaPro, in order to conduct the gearbox LCIA. The sequence of modelling and calculation is as follows: parts, subassemblies, assembly and life cycle including distribution, disposal, disassembly, and reuse. Step by step, each part has a value of ecological impact; when the parts are assembled together to form a subassembly, extra ecological impact will be produced during assembly process, such as human labour, electricity consumption or others. The same situation happens when subassemblies are assembled together to form the assembly.

At first, all geometry dimensions of each part including the parameters and their values are inputted in ‘input parameters’ provided by SimaPro. And then, all the calculated parameters are explained into formation in ‘calculated parameters’ provided below as the ‘input parameters’. In that case, the software, SimaPro, calculates them automatically. After that, all amounts that the materials used for blanks of parts and

Fig. 9.7 Example of modelling the product stages and part list in SimaPro

Product stages	Name
- Assembly	bolt m10*35
- Assembly	bolt m12*100
- Others	bolt m6*15
- Part	bolt m6*20
- Subassembly	bolt m8*25
+ Life cycle	case base
+ Disposal scenario	case cover
+ Disassembly	gear
+ Reuse	high speed bearing end cap
	high speed shaft
	high speed shaft bearing
	low speed bearing end cap
	low speed shaft
	low speed shaft bearing
	nut m10
	nut m12

cut off by each manufacture process are calculated. All these mass data are inputted in corresponding extrusion or manufacture process in input/output page provided by SimaPro.

The modelling of all parts, subassemblies, assemblies, disposal, disassembly, reuse, and the recycle of gearbox are completed in corresponding menus. For the disposal of the gearbox after the end of its life, all the parts are assumed to be treated as waste scenario, which is a waste distribution list indicated different waste treatments for different waste types in England.

#### **9.4.1.3 Life Cycle Impact Assessment of the Gearbox Design**

To conduct the LCIA, all the data of the gearbox are processed first, including the geometric data of the assembly, subassembly and parts; information of materials, lubricants, packaging, etc.; and the lifecycle data, such as production process, transportation, use, and disposal. Those data are then inputted into SimaPro to modelled the gearbox to carry out the LCIA. After obtaining the results, necessary analyses have to be carried out. Based on the results obtained, redesign or optimisation may be carried out in order to achieve a best solution to reduce the gearbox's ecological impact. Potential plans of optimisation may include:

- To extend the service life of gearbox
- To increase the recycle rate of used material
- Optimisation design of original gearbox life cycle with eco-constraints using Genetic Algorithm (GA)

The details of the gearbox LCIA are presented in Chap. 10.

### **9.4.2 GA Optimisation Using MATLAB**

After the LCIA of the gearbox, it has a potential to reduce the ecological impact through optimisation using genetic algorithm. The LCIA results reveal that the materials have effects on the ecological impact of the gearbox, as shown Chap. 10. Therefore, a structural optimum design considering ecological impact should be implemented by reducing the materials used in the gearbox. The structural optimum design has two phases, including size optimisation and shape optimisation.

Before conducting the optimum design, the objectives, constraints, and variables should be defined. The objective of the optimisation is to obtain a solution to reduce the ecological impact. That is the fitness functions, which evaluate individuals in the population and meet the required performance of the product. Some parameters are set as variables in the optimisation problem. All of other parameters, such as dimension, distance, time and weight, which are involved in the ecological impact calculation of gearbox life cycle, are assigned based on the gearbox design. Constraints include dimension bound, performance and strength check, which are expressed by

inequality or equality. When objectives, variables, and constraints are defined, the optimisation can be conducted which is underpinned with the optimisation toolbox solvers of the software MATLAB.

After applying the method to reduce the materials of the product, the results will be compared with the original design using SimaPro, and analysed to prove the feasibility of the optimised design.

**9.4.2.1 Objective of the Optimisation**

The ecological impact of the gearbox is the objective function in this case study. The function is expressed by the summation of all ecological impact calculation functions of the parts, subassemblies, assemblies, and stages in the whole life cycle.

**9.4.2.2 Ecological Impact of the Gearbox**

The information required to calculate the ecological impact (EI) of the gearbox contains four main parts, including EI of assembly of gearbox, EI of additional life cycle, EI of gearbox disposal, and EI of transport, as shown in Eq. (9.1). EI of assembly of gearbox is the sum of that of subassemblies, human labour, and electricity consumed in production of the parts, as shown in Eq. (9.2). EI of subassembly is the sum of ecological impacts of all subassemblies including high speed shaft, low speed shaft, case, bolts and nuts, and human labour spent during assembling of them, as shown in Eq. (9.3).

$$EI_{gb} = EI_{as} + EI_a + EI_{dis} + EI_t \tag{9.1}$$

- $EI_{gb}$  Ecological impact of gearbox life cycle
- $EI_{as}$  EI of assembly of gearbox
- $EI_a$  EI of additional life cycle
- $EI_{dis}$  EI of disposal of gearbox
- $EI_t$  EI of transport

$$EI_{as} = EI_{sub} + EI_{hl} + EI_e \tag{9.2}$$

- $EI_{sub}$  EI of subassembly
- $EI_{hl}$  EI of human labour
- $EI_e$  EI of electricity

$$EI_{sub} = EI_{s\_hss} + EI_{s\_lss} + EI_{s\_c} + EI_{s\_bn} + EI_{hl} \tag{9.3}$$

- $EI_{s\_hss}$  EI of subassembly of high speed shaft
- $EI_{s\_lss}$  EI of subassembly of low speed shaft



- $EI_{s_c}$  EI of subassembly of case  
 $EI_{s_bn}$  EI of subassembly of bolts and nuts  
 $EI_{hl}$  EI of human labour

EI of the subassembly of high speed shaft is the sum of that of the high speed shaft, two bearings mounted at the high speed shaft, and human labour involved during their manufacture, as shown in Eq. (9.4).

$$EI_{s\_hss} = EI_{hss} + EI_{hssb} + EI_{hl} \quad (9.4)$$

- $EI_{hss}$  EI of the high speed shaft  
 $EI_{hssb}$  EI of two high speed shaft bearing  
 $EI_{hl}$  EI of human labour

EI of the high speed shaft consists of two parts, ecological impacts of processing and material production. The ecological impact of processing is calculated by the mass of cut pieces from blank multiplying the ecological impact of process applied on high speed shaft manufacture per unit. The ecological impact of material production is calculated by the mass of the material used for the blank multiplying the ecological impact of the material extraction per unit. For example, the ecological impact of a 2 kg ferro blank is equal to the mass (2 kg) multiply the impact of iron production per kg, 3 pts, which is  $2 \times 3 = 6$  pts. Then the impact of cutting the blank is equal to the mass that is cut down by machine, 0.5 kg, multiply the impact of cutting iron per kg, 1pt, which is  $0.5 \times 1 = 0.5$  pt. So, the impact of this piece is equal to that of material production plus manufacture,  $6 + 0.5 = 6.5$  pts.

Also, the mass can be turned into product of volume and density of material, as shown in Eq. (9.5). The EI of other subassemblies are followed the same calculation principle as the EI of the high speed shaft subassembly.

$$EI_{hss} = M_p \times EI_p + M_b \times EI_e = (V_b - V_{hss}) \times \rho \times EI_p + V_b \times \rho \times EI_e \quad (9.5)$$

- $M_p$  Mass of cut pieces from blank  
 $EI_p$  EI of process applied on high speed shaft manufacture per unit  
 $M_b$  Mass of blank  
 $EI_e$  EI of material extraction per unit  
 $V_b$  Volume of blank  
 $V_{hss}$  Volume of high speed shaft  
 $\rho$  Density of material

As description in section of life cycle modelling of gearbox and Calculation of ecological impact. These data are written in the spread sheet and ready for use by MATLAB to do the optimisation. The complete formation to calculate the ecological impact of the gearbox life cycle is given in (Ren 2013).

**Table 9.1** Dimensions of the key parts related to the variables

Parameter	Symbols	Default value	Calculation parameter	Relation with variables
Blank diameter of gear-shaft		70	gs_blank_d = gs_d5 + 5	$x1 \times 20 + 10$
Reference circle diameter of gear-shaft (mm)	d1	65	gs_d5	$x1 \times 20 + 5$
Reference circle diameter of gear (mm)	d2	237	g_b_d	$x1 \times x2$
Tooth face-width of gear-shaft	b1	65	gs_l5	$x3$
Tooth face-width of gear	b2	60	g_b_l	$x3 - 5$

**9.4.2.3 Optimisation Variables**

Three parameters are set as variables in the optimum problem, including module of gear, x1, number of teeth of gear x2, and face-width of gear-shaft, x3. Their default values are 3, 79 and 65 respectively. In the optimisation process, the variables are initially assigned with the default values. The default values are then replaced with new values along with the optimisation progression, and are assigned with the final optimised values at the end of the optimisation. The three variables, x1, x2 and x3, are the basics determining the dimensions of the gear-shaft and gears, as shown in Table 9.1, which are the key parts affecting the size of the gearbox.

**9.4.2.4 Optimisation Constraints**

The constrains for optimisation of sustainable design considered in this case study include the gear tooth contact strength and bending strength, i.e.,

$$\text{The contact stress } \sigma_H \leq \text{allowable contact stress } [\sigma_H] \tag{9.6}$$

$$\text{The bending stress } \sigma_f \leq \text{allowable bending stress } [\sigma_f] \tag{9.7}$$

The tooth contact stress can be calculated as follows

$$\sigma_H = Z_H Z_\epsilon Z_e \left( \frac{K_a K_v K_\beta F_t (\mu + 1)}{b_1 d_1 \mu} \right)^2 \leq [\sigma_H] \tag{9.8}$$

where the meanings of the symbols and their corresponding values or calculation functions are as follows according to Zhong et al. (2001):

$\sigma_H$	Calculated contact stress (MPa)
$Z_e$	Elastic coefficient = 191
$Z_H$	Node area coefficient, function of variable x1
$Z_\varepsilon$	Contact ratio coefficient, function of variable x2
$K_a$	Application factor = 1
$K_V$	Dynamic factor = 1.1
$K_\beta$	Load distribution factor = 1.0525
$F_t$	Periphery force on reference circle (N), function of x1 and x2
$\mu$	Transmission ratio = 3.95
$b_1$	Face width of gear-shaft (mm), function of variable x3
$d_1$	Reference circle diameter of gear-shaft = x1 × x2 mm
$[\sigma_H]$	Allowable contact stress = 647 MPa

The tooth bending stress can be calculated as follows

$$\sigma_f = \frac{K_a K_V K_\beta F_t Y_{sa} Y_{fa}}{b_1 m} \leq [\sigma_f] \quad (9.9)$$

where the meanings of the symbols and their corresponding value or calculation functions are as follows according to Zhong et al. (2001):

$\sigma_f$	Calculated bending stress of gear (MPa)
$K_a$	Application factor = 1
$K_V$	Dynamic factor = 1.1
$K_\beta$	Load distribution factor = 1.0525
$F_t$	Periphery force on reference circle (N), function of x1 and x2
$Y_{sa}$	Tooth form factor = 1.55
$Y_{fa}$	Stress correction factor = 2.8
$m$	Module of gear, function of variable x1
$b_1$	Face width of gear-shaft (mm), function of variable x3
$[\sigma_f]$	Allowable bending stress of gear = 260 MPa

The stress calculations, including determination of the parameters involved in the stresses, are complicated and their expressions take more spaces. Because the limitation of the length of this chapter, they are only briefly expressed as above. Their further details can be found in Ren (2013).

#### 9.4.2.5 Optimisation Bounds

Optimisation bounds are come from all inequalities of gear dimension constraints (9.6) and (9.7), minimum number of teeth, and minimum module. The intersection of these sets is a range of optimisation solution sets.

At first, bounds are calculated based on gear dimension constraints of forging gear whose diameter is less than 500 mm as Fig. 9.8 shows. And then, teeth number of the gear must not less than 17 to avoid undercut. Moreover, teeth number of gear-shaft

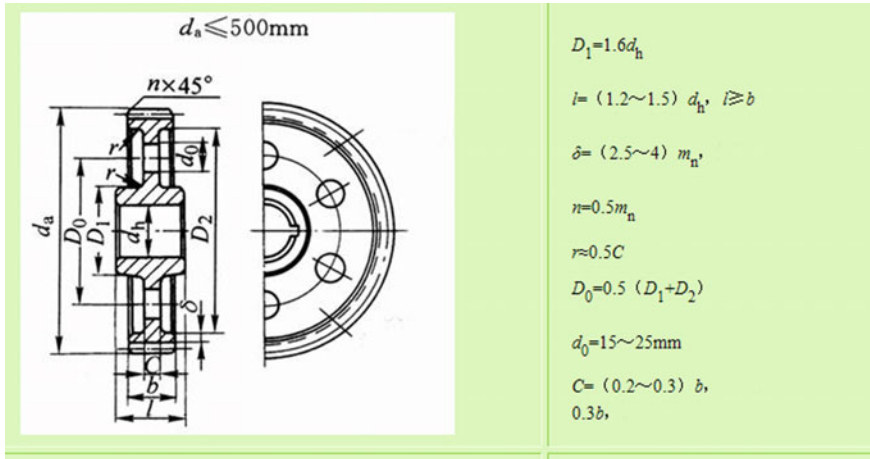

**Fig. 9.8** Dimension of forging gear

is 20. The teeth number of gear must not less than 20 to insure that the machine is a reducer not increaser. Usually, module of gear is equal to or greater than 2. The gear tooth width is within the range between 55 and 80 mm.

**9.4.2.6 Determination Guidelines of Stopping Criteria**

During the optimisation process, the stopping criteria can be changed according to specific situation.

(1) *Generations, time limit*

In this optimisation, and the optimisation time is set unlimited. This is because the fitness and objective functions are concerned, but not the time consumption. Certainly, they should be limited if the process of optimisation is too long that beyond designer’s tolerance. The generation is set to the default value in MATLAB, 100. After 100 generations, the fitness appears with a steady state, which means it has reached the best solution. If it still changes at that point, the designer can increase the limit number of generations.

(2) *Fitness limit*

Fitness limit is an upper boundary of value of fitness function. When the value of fitness function reaches or is less than the limit. The optimisation will stop. In this optimisation, minimum value of fitness function is a solution. Besides, less value is better solution. So, this option can be set to default value which is ‘infinite’.

### (3) *Stall generations*

This stopping criteria works based on function tolerance setting. If the weighted average change in fitness function value over stall generations, which is called iterative generations, is less than the function tolerance, the optimisation will stop. This setting should be set to an appropriate value, for example, default value is 50. If the value is too small, the solution may be the local minimum, which is not the best point to the optimisation. If the value is too large, the optimisation will be a time-consuming task, and most of working time may be waste. Certainly, it also relates to the set of function tolerance.

### (4) *Function tolerance*

As mentioned above, it works with stall generations. In the stage of checking function tolerance and weighted average change in fitness function value over stall generations, the solution may be the local minimum if the function tolerance is set to too large value. The process of optimisation will waste a lot of time or be endless if the value is set to too small.

### (5) *Stall time limit*

Usually, time cost is not too much to wait for a result over stall generations. So, default value of it is often kept.

When the process stopped by meeting one of stopping criteria, the optimal solution set is obtained. The optimisation process should run several times under different settings of stopping criteria to avoid obtaining a larger local minimum in boundary. The parameters of crossover, mutation, and elite take the default values provided by MATELAB in this case, because the best solution can be found when it stops. User can modify them if the solution cannot be found.

## 9.5 Optimisation Results and Discussion

### 9.5.1 *Results Related to the GA Features*

After the definition of objectives, constraints, variables, and optimisation bounds, the optimisation process can be transferred into optimisation tool of MATLAB as the Fig. 9.2. During execution process, some of options is changed for the optimisation. The initial population is set as [3, 79, 65] which are the default value of variables. It means that the optimisation starts from the point of these default values. Plenty of time is saved after setting the option. Function tolerance in the stopping criteria is set as zero, because the best solution set is concerned but not the time consumption.

The optimisation results of ecological impact is illustrated in the Fig. 9.9. The best objective value is 23.5197 as the figure in left top corner. The score is approaching

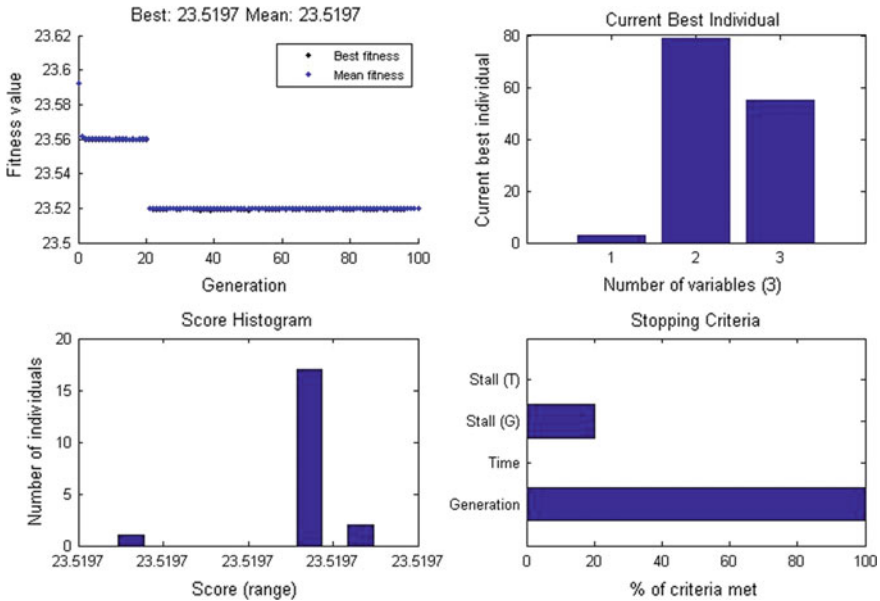

Fig. 9.9 Best fitness, best individual, score diversity, and stopping criteria of optimisation

the best point after about 20 generations. In the end it is close to the best score. The original value is 25.3511 when variables are the default values, [3, 79, 65]. The solution set are [2.781, 79.103, 55] as the figure in the right top corner. The figure in left bottom corner shows that most of score are around 23.5197. The figure in right bottom corner shows the generation reaches 100 is the stopping criterion of the optimisation. Before obtaining the results, the optimisation always stopped by meeting the criterion of the stall generation. So the option of stall generation has changed from default value, 50 to 100. The score after optimisation is smaller than the original one, so the optimisation is achieved.

Based on the results, solution set is [2.8, 78, 55]; because 2.8 is not a standard value of gear tooth module, a standard value 3 is taken as the module. After put these values [3, 78, 55] into the function of objectives, the value of objective function of ecological impact is 23.5104.

### 9.5.2 Comparison Results of Ecological Impact

Before the LCIA comparison between the original gearbox life cycle and optimised one, variables in the optimisation function of EI should be replaced by calculation parameters again as that before the optimisation. The replacement details are presented in Table 9.2.

**Table 9.2** Replacement values of variables

Parameters	Symbols	Default values	Optimised values	Calculation parameter in SimaPro	Relation with variable
Blank diameter of gear-shaft		70	66	$gs\_blank\_d = gs\_d5 + 5$	$x1 \times 20 + 10$
Reference circle diameter of gear-shaft (mm)	d1	65	61	gs_d5	$x1 \times 20 + 5$
Reference circle diameter of gear (mm)	d2	237	218.4	g_b_d	$x1 \times x2$
Face-width of gear-shaft	b1	65	55	gs_l5	$x3$
Face-width of gear	b2	60	50	g_b_l	$x3 - 5$

Figures 9.10 and 9.11 shows the comparison of two LCIA, red bars represents the impacts of original gearbox life cycle. Blue bars represent the impacts of optimised gearbox life cycle.

The comparison of characterisation results shows the impacts of optimised one is average 94% of the impacts of original one in midpoint categories, except for metal depletion, which is only 90% of that.

The comparison of damage assessment shows that the impacts of optimised one is 92% of the impacts of original one in human health and resources categories, and 93% in ecosystems.

Figure 9.12 illustrates the comparison results after weighting. The impact of optimised one in human health is about 1pt lower. The impact in ecosystems and resources is less than 1pt lower than before.

Figure 9.13 presents life cycle single scores of the original and optimised gear-boxes. The result is similar as that of weighted results. The impact of two life cycle is 23.51pt and 25.35pt respectively. The decrement of impact is approximately 7%. The optimisation design of gearbox life cycle is proved.

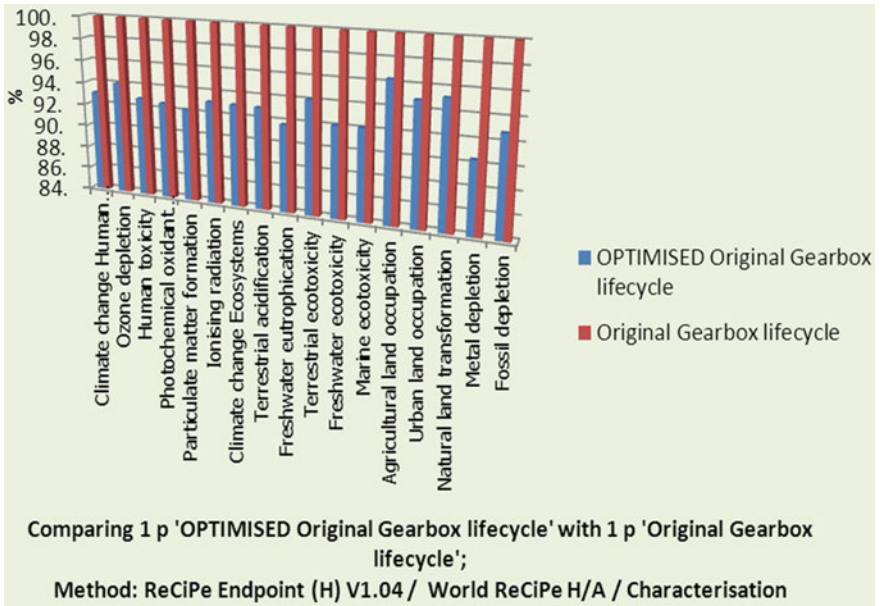

Fig. 9.10 Characterisation and damage assessment with ReCiPe mid-point indicators

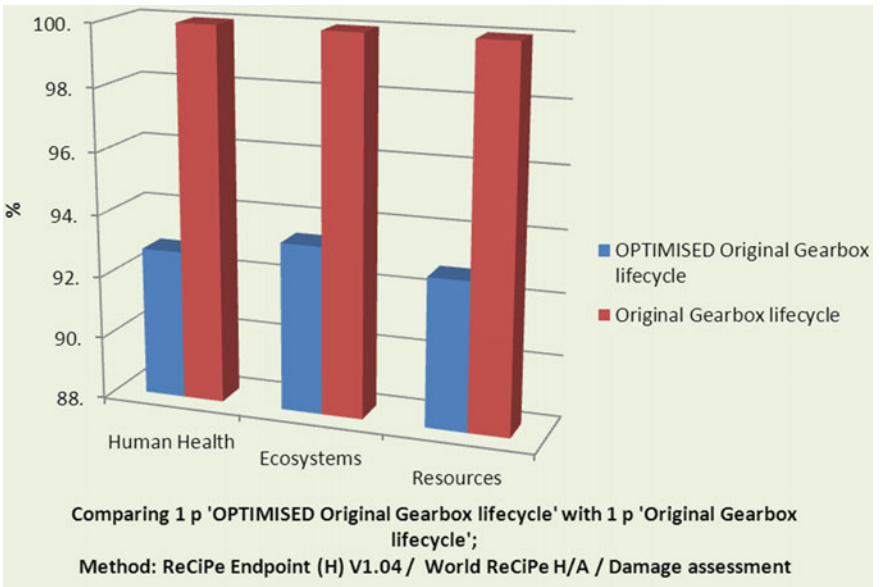

Fig. 9.11 Characterisation and damage assessment with ReCiPe end-point indicators



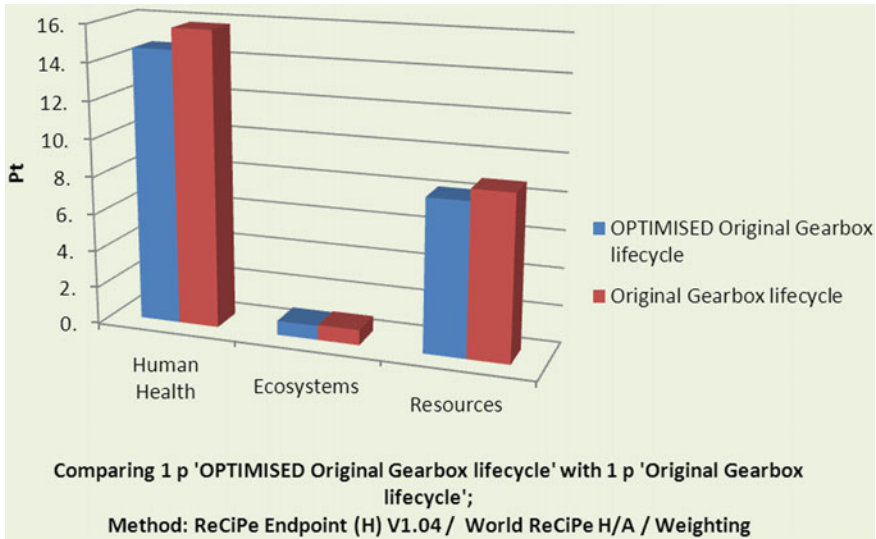

Fig. 9.12 Comparison results after weighting between original gearbox life cycle and optimised gearbox life cycle

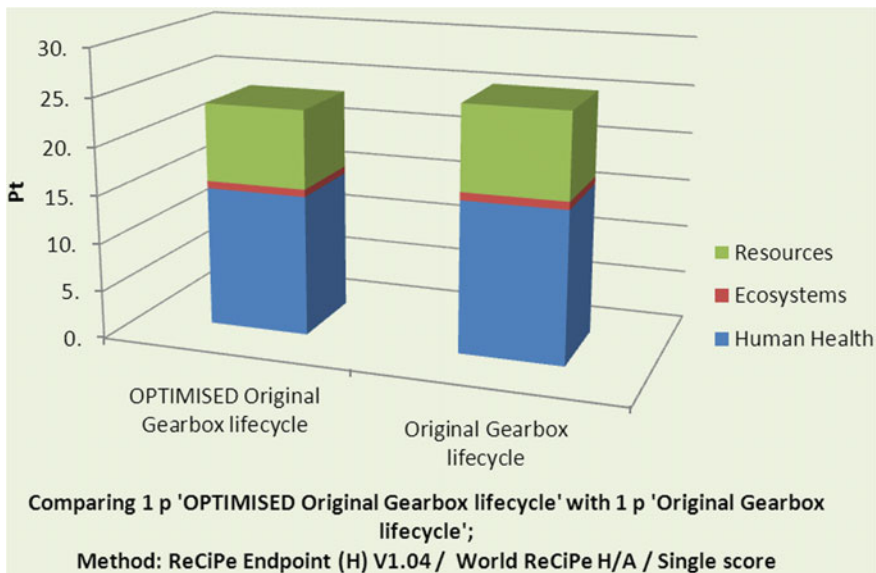

Fig. 9.13 LCIA comparisons between original gearbox life cycle and optimised gearbox life cycle

## 9.6 Conclusion

This Chapter introduces the Genetic Algorithm. Its advantage and limitation are analysed to explain why it is a widely used method for optimisation, and MATLAB, a powerful tool for implementing the GA is also introduced, including a series of tips for use. And then the approach of sustainable product design optimisation with GA is presented, which is illustrated with a case study of industrial gearbox where the MATLAB is utilised along with the life cycle assessment using a life cycle impact assessment tool.

There have been a large number of sustainable product designs, but how to systematically optimise sustainable designs is a still challenge task. The proposed sustainable product design optimisation approach developed in this research is a valuable contribution to this subject area.

The objective of the case study is to reduce the ecological impact of the gearbox. The optimisation results reveals that the objective has been well achieved, and, hence, it approved the success of the proposed approach.

## References

- Cambridge dictionary. (2018). Retrieved December 17, 2017, from <https://dictionary.cambridge.org/dictionary/english/optimization>.
- Choi, J. W., Lee, H., Lee, J. C., Lee, S., Kim, Y. S., Yoon, H.-J., & Kim, H. C. (2017). Application of genetic algorithm for hemodialysis schedule optimization. *Computer Methods and Programs in Biomedicine*, *145*, 35–43. doi:<https://doi.org/10.1016/j.cmpb.2017.04.003>. ISSN: 0169-2607.
- Gen, M., & Cheng, R. (1997). *Genetic algorithms and engineering design*. New York: Wiley.
- Geweda, A. E., El-Gohary, M. A., El-Nabawy, A. M., & Awad, T. (2017). Improvement of vehicle ride comfort using genetic algorithm optimization and PI controller. *Alexandria Engineering Journal*, *56*(4), 405–414. <https://doi.org/10.1016/j.aej.2017.05.014>. ISSN: 1110-0168.
- Goldberg, D. (1989). *Genetic algorithms in search, optimisation and machine learning*. Reading, MA: Addison-Wesley.
- Gong, G., Pan, P., Chen, X., & Yan, L. (1981). *Examples of machine element and system designs for mechanical design course*. Harbin, China: Harbin Institute of Technology Press.
- Hu, Y., Tan, C. K., Broughton, J., Paul Alun Roach, P. A., & Varga, L. (2017). Model-based multi-objective optimisation of reheating furnace operations using genetic algorithm. *Energy Procedia*, *142*, 2143–2151. <https://doi.org/10.1016/j.egypro.2017.12.619>. ISSN 1876-6102.
- Lu, M., & Ye, J. (2017). Guided genetic algorithm for dome optimization against instability with discrete variables. *Journal of Constructional Steel Research*, *139*, 149–156. <https://doi.org/10.1016/j.jcsr.2017.09.019>. ISSN 0143-974X.
- MATLAB. Retrieved September 30, 2018, from <https://uk.mathworks.com/products/matlab.html>.
- Oxford Dictionaries. (2018). Retrieved October 7, 2018, from <https://en.oxforddictionaries.com/>.
- Ren, Z. (2013). *Sustainable design approach underpinned with life cycle impact assessment (LCIA) and ontology*. Ph.D. thesis, Nottingham Trent University, UK. Retrieved October 7, 2018, from <http://irep.ntu.ac.uk/id/eprint/75/>.
- Ren, Z. & Su, D. (2014). Comparison of different life cycle impact assessment software tools. In *Key Engineering Materials* (Vol. 572, pp. 44–49). EI Index doi:<https://doi.org/10.4028/www.scientific.net/KEM.572.44>.

- Su, D. & Ren, Z. (2011). Ecological impact assessment and eco-design of industrial gearboxes. *Key Engineering Materials* (Vol. 486, pp. 197–200). EI Index doi:<https://doi.org/10.4028/www.scientific.net/KEM.486.197>.
- West, A., Montazeri, A., Monk, S. D. & Taylor, C. J. (2016). A genetic algorithm approach for parameter optimization of a 7DOF robotic manipulator, *IFAC-Papers On Line*, 49(12), 1261–1266. <https://doi.org/10.1016/j.ifacol.2016.07.688>. ISSN: 2405-8963.
- Zhong, Y., Wu, C., and Tang, Z., (2001). Mechanical design, Huazhong University of Science & Technology Press.

**Part III**  
**Case Studies of Product Life Cycle**  
**Assessments**

# Chapter 10

## Gearbox Life Cycle Assessment



Daizhong Su and Zhongming Ren

**Abstract** Sustainable production has been attracting more and more attention nowadays. Gearbox is a widely applied mechanical engineering product. However, little work of life cycle assessment (LCA) aimed at the gearbox could be found in the literature. This paper presents a LCA of gearbox to fill in the gap. The life cycle of the gearbox is modelled parametrically with a three-tier approach. Eco-impact caused by human labour is considered in the LCA. The LCA is conducted using a popular LCA software, SimaPro, and a widely accepted life cycle impact assessment method, ReCiPe. Based on analysis of the results, optimisation plans are proposed at the end.

**Keywords** Life cycle assessment · Life cycle impact assessment · Gearbox · LCA · LCIA · Environmental impact · Parametric modelling · Product design

### 10.1 Introduction

In recent years, sustainable development have been risen as a popular topic, and sustainable production has been attracting more and more attention. Life cycle assessment (LCA) of mechanical engineering products has been considered as an important aspect of the sustainable production. Gearbox is a widely applied mechanical product in industry. However, according to the literature survey conducted by the authors, little work has been done for LCA of gearboxes. This paper presents an LCA of representative single-stage gearbox to fill the gap.

---

D. Su (✉)

School of Architecture, Design, and Built Environment, Advanced Design and Manufacturing Engineering Centre, Nottingham Trent University, Nottingham, UK  
e-mail: [daizhong.su@ntu.ac.uk](mailto:daizhong.su@ntu.ac.uk)

Z. Ren

School of Art and Design, Shanghai University of Engineering Science, No. 333 Longteng Road, Songjiang 201620 Shanghai, China  
e-mail: [zren@sues.edu.cn](mailto:zren@sues.edu.cn)

Shanghai Institute of Design and Innovation, Tongji University, No. 281 Fuxin Road, Yangpu 200092 Shanghai, China

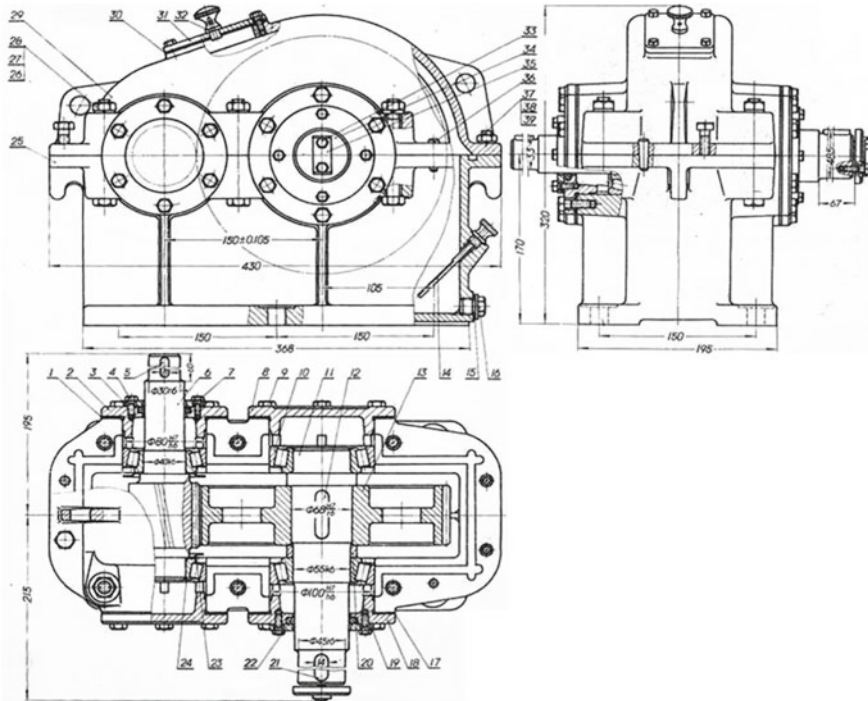

**Fig. 10.1** Gearbox assembly drawing (Gong et al. 1981)

In this research, a popular LCA software, SimaPro, and a well-known life cycle impact assessment (LCIA) method, ReCiPe, are used to conduct the LCA of the gearbox.

SimaPro has number of advanced features for LCA, such as friendly user interface, specific presentation of LCA results, and embedded ecoinvent database, which is a comprehensive Life Cycle Inventory (LCI) database. Furthermore, its parameter function provides the foundation of parametric modelling of the gearbox.

ReCiPe comprises harmonised category indicators at the midpoint and the endpoint level (ReCiPe, nd.). This method is an improvement on CML 2001 method (Guinée et al. 2001) and Eco-indicator 99 method (Baayen 2000). The method calculates eighteen midpoint indicators and sum up these midpoint indicators into three endpoint indicators. Because the eighteen midpoint indicators are not easy to interpret, the three endpoint indicators are more understandable. User can choose at which level it wants to have the result.

## 10.2 Parametric Modelling of the Gearbox Life Cycle

A single-stage industrial gearbox, as shown in Fig. 10.1, is taken as the object of the LCA. It is the same gearbox presented in Chap. 9 where more information of the gearbox can be found.

The modelling mainly consists of two stages, modelling of the assembly and its production, and the rest of phases within the product life cycle, including transport, disposal, disassembly, and waste scenario.

The parameter function provided within the SimaPro has two modules, 'input parameters' and 'calculated parameters'. Parameters' name and their values can be defined by user in the 'input parameters'. In the calculated parameters, new complicated parameters can be defined as expressions of input parameters listed previously. Meanwhile, these parameters will be calculated simultaneously and automatically by SimaPro. The function offers the foundation of the parametric modelling of the life cycle.

The parametric modelling of the assembly and its production are divided into two aspects, material extraction and mechanical process. The ecoinvent database contains life cycle inventory of mainstream material extractions and mechanical processes. With the help of ReCiPe LCIA method, these inventories can be converted into environmental impact per unit of mass. Therefore, mass of material extraction and mechanical process of each part should be defined firstly. All geometry dimensions of each part are defined in the input parameters module and volume of blanks and processed parts are expressed as formations of input parameters in calculated parameters module. With density of each kind of material, the mass can be obtained accordingly.

Following the Three-tiers approach for calculation of LCIA scores proposed in Chap. 9, the gearbox assembly is broken into three tiers as shown in Fig. 10.2: (1) parts, including one spur gear, one high speed shaft, one low speed shaft, two bearings for low speed shaft, two bearings for high speed shaft, five kinds of bolts, two kinds of nuts, one case base, one case cover, and four bearing end caps, etc. (2) sub-assemblies, including high speed shaft assembly, low speed shaft assembly, case, bolts, and nuts; and (3) assembly, i.e., the gearbox. All the parts, subassemblies, and assembly are set up as parametric models in mentioned method. The impact of them will be summed up tier by tier to form the impact of the assembly.

After that, all amounts that the materials used for blanks of parts and cut off by each manufacture process are taken into account. All these mass data are inputted in corresponding extraction or manufacture process in input/output module of the SimaPro. In addition, human labour impact (Su and Ren 2011) involved in the production of each part are considered as well.

The modelling of the rest phases within the life cycle, including transport, disposal, disassembly, and waste scenario of gearbox are completed in corresponding modules provided by SimaPro. For the disposal of the gearbox after the end of its life, all the parts are assumed to be treated as waste scenario, which is a waste distribution list indicated different waste treatments for different waste types in England, provided by PRé in SimaPro.

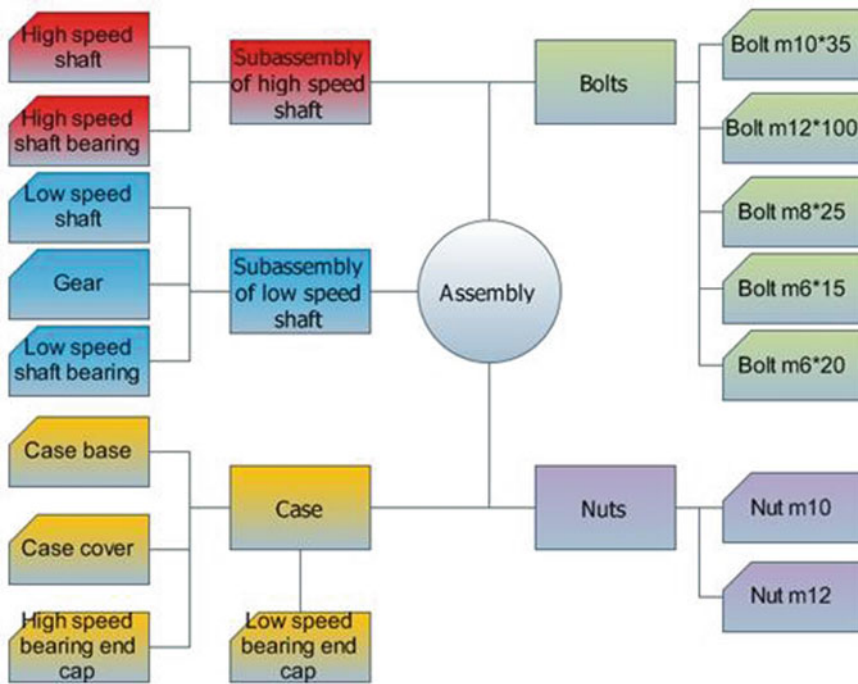

Fig. 10.2 Gearbox assembly breakdown structure

### 10.2.1 Modelling of the Gearbox Assembly

As shown in Fig. 10.2, the gearbox assembly is consist of five subassemblies. Each subassembly has number of parts. There are sixteen kinds of parts. Some subassemblies have more than one piece of a kind of part. Such as bearings and bearing end caps, they are always assembled in couples. Also, numbers of bolts and nuts are assembled to tighten the case base and case cover. Completed list of parts is illustrated in Table 10.1. In total, there are 68 parts. In each stage of modelling, number of parts will be multiplied and taken into account of whole results of LCIA.

#### 10.2.1.1 Part Modelling

Modelling in SimaPro uses parametric manner as mentioned. Each parameter must have a unique name in the whole project to avoid confusion. The ecological impact comes from two sections, material extraction and process. The modelling of parts is based on this principle. The extraction of used material and manufacture process amount will be modelled for each part.



**Table 10.1** Parts list of each subassembly

Subassembly	Part	Piece
Subassembly of high speed shaft	High speed shaft	1
	High speed shaft bearing	2
Subassembly of low speed shaft	Low speed shaft	1
	Low speed shaft bearing	2
	Gear	1
Case	Case base	1
	Case cover	1
	High speed bearing end cap	2
	Low speed bearing end cap	2
Bolts	bolt m10*35	3
	bolt m12*100	6
	bolt m8*25	24
	bolt m6*20	2
	bolt m6*15	12
Nuts	nut m10	2
	nut m12	6
Total		68

High speed shaft is a gear-shaft made by low-alloyed steel as shown in Fig. 10.3. Mass of material used for blank is a calculated parameter named blank\_mass, which is calculated from input parameters below as Table 10.2. The blank\_mass is obtained by blank\_volume multiples density of the material, AISI1040, which is estimated as 7.85e-6 kg/mm<sup>3</sup>. The density is valued by the average value of the range of density from 7.8e-6 to 7.9e-6 kg/mm<sup>3</sup>. Blank\_volume is the volume of a cylinder metal blank. The formula to calculate the volume is shown below and in Table 10.2.

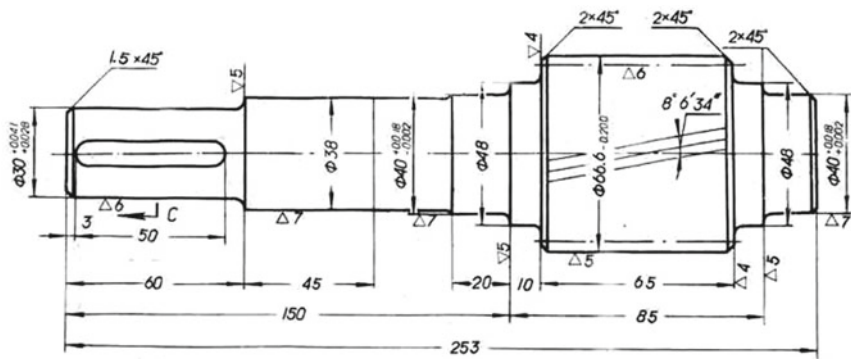

**Fig. 10.3** Drawing of the shaft (Gong et al. 1981)

**Table 10.2** High speed shaft modelling parameters

Name	Value	Unit
High speed shaft		
<i>Materials/assemblies</i>		
Steel, low-alloyed, at plant/RER U	blank_mass	kg
<i>Processes</i>		
Turning, steel, conventional, average/RER U	gs_scrap_m-0.1	kg
Milling, steel, average/RER U	0.1	kg
Human labour	1	hr
<i>Input parameters</i>		
blank_length	253	mm
blank_diameter	70	mm
gs_L1	60	mm
gs_L2	70	mm
gs_L3	38	mm
gs_L4	20	mm
gs_L5	65	mm
gs_d1	30	mm
gs_d2	38	mm
gs_d3	40	mm
gs_d4	48	mm
gs_d5	65	mm
<i>Calculated parameters</i>		

(continued)

**Table 10.2** (continued)

Name	Value	Unit
blank_volume	$\pi/4 * \text{blank\_diameter}^2 * \text{blank\_length}$	mm <sup>3</sup>
gear-shaft_volume	$\pi/4 * (\text{gs\_d1}^2 * \text{gs\_l1} + \text{gs\_d2}^2 * \text{gs\_l2} + \text{gs\_d3}^2 * \text{gs\_l3} + \text{gs\_d4}^2 * \text{gs\_l4} + \text{gs\_d5}^2 * \text{gs\_l5})$	mm <sup>3</sup>
gs_scrap_v	blank_volume-gear-shaft_volume	mm <sup>3</sup>
blank_mass	blank_volume*7.85e-6	kg
gs_scrap_m	gs_scrap_v*7.85e-6	kg

$$\text{blank\_volume} = \frac{\pi}{4} * \text{blank\_diameter}^2 * \text{blank\_length} \quad (10.1)$$

The input parameters include the length and diameter of the blank, *blank\_length* and *blank\_diameter*, and five different length and diameter of each stage of the gear-shaft, *gs\_L1*, *gs\_L2*, *gs\_L3*, *gs\_L4*, *gs\_L5*, *gs\_d1*, *gs\_d2*, *gs\_d3*, *gs\_d4*, *gs\_d5*. Calculated parameters include the volume and mass of the blank, and the volume of gear-shaft, *gear-shaft\_volume*, which is calculated from input parameters as shown in formula (10.2).

$$\begin{aligned} \text{gearshaft\_volume} = & \frac{\pi}{4} * (\text{gs\_d1} * \text{gs\_l1} + \text{gs\_d2}^2 * \text{gs\_l2} + \text{gs\_d3}^2 * \text{gs\_l3} + \text{gs\_d4}^2 * \text{gs\_l4} \\ & + \text{gs\_d5}^2 * \text{gs\_l5}) \end{aligned} \quad (10.2)$$

And then, the scrap cut off during the process of gear-shaft manufacture is obtained. *gs\_scrap\_v* is the volume of the scrap which is equal to the difference between that of the blank and that of the gear-shaft. The mass of the scrap, *gs\_scrap\_m*, is acquired by multiplying the density of the material.

Low speed shaft is a shaft as shown in the bottom of Table 10.3. Material of blank is same as the high speed shaft. Mass of material used for blank is a calculated parameter named *blank\_m*, which is calculated from input parameters below as Table 10.3. The *blank\_m* is obtained by *blank\_v* multiples density of the material, which is same as the high speed shaft. The *blank\_v* is the volume of a cylinder metal blank. The formula to calculate the volume is shown below and in Table 10.3.

$$\text{blank\_v} = \frac{\pi}{4} * \text{blank\_d}^2 * \text{blank\_l} \quad (10.3)$$

The input parameters include the length and diameter of the blank, *blank\_l* and *blank\_d*, and five different length and diameter of each stage of the shaft, *s\_l1*, *s\_l2*, *s\_l3*, *s\_l4*, *s\_l5*, *s\_d1*, *s\_d2*, *s\_d3*, *s\_d4*, *s\_d5*. Calculated parameters include the volume and mass of the blank, and the volume of shaft, *shaft\_v*, which is calculated from input parameters through formula 10.4.

$$\text{shaft\_v} = \frac{\pi}{4} * (\text{s\_d1}^2 * \text{s\_l1} + \text{s\_d2}^2 * \text{s\_l2} + \text{s\_d3}^2 * \text{s\_l3} + \text{s\_d4}^2 * \text{s\_l4} + \text{s\_d5}^2 * \text{s\_l5}) \quad (10.4)$$

And then, the scrap cut off during the process of shaft manufacture is obtained. *s\_scrap\_v* is the volume of the scrap which is equal to the difference between that of the blank and that of the shaft. The mass of the scrap, *s\_scrap\_m*, is acquired by multiplying the density of the material. During the process of shaft manufacture, the scrap is cut off by turning and milling. 0.1 kg is estimated as the mass of milling, which is finishing processing. The remind mass of scrap is the mass of turning. As the table shows, turning mass is equal to *s\_scrap\_m*-0.1 kg. Human labour used for manufacture of low speed shaft is about one hour.

**Table 10.3** Low speed shaft modelling parameters

Name	Value	Unit
Low speed shaft		
<i>Materials/assemblies</i>		
Steel, low-alloyed, at plant/RER U	blank_m	kg
<i>I Processes</i>		
Turning, steel, conventional, average/RER U	s_scrap_m-0.1	kg
Milling, steel, average/RER U	0.1	kg
Human labour	1	hr
<i>Input parameters</i>		
blank_l	255	mm
blank_d	65	mm
s_l1	62	mm
s_l2	67	mm
s_l3	57	mm
s_l4	57	mm
s_l5	12	mm
s_d1	45	mm
s_d2	52	mm
s_d3	55	mm
s_d4	58	mm
s_d5	65	mm
<i>Calculated parameters</i>		
blank_v	$\pi/4 \cdot \text{blank\_d}^2 \cdot \text{blank\_l}$	
shaft_v	$\pi/4 \cdot (\text{s\_d1}^2 \cdot \text{s\_l1} + \text{s\_d2}^2 \cdot \text{s\_l2} + \text{s\_d3}^2 \cdot \text{s\_l3} + \text{s\_d4}^2 \cdot \text{s\_l4} + \text{s\_d5}^2 \cdot \text{s\_l5})$	
s_scrap_v	blank_v - shaft_v	
blank_m	blank_v * 7.85e-6	

(continued)

**Table 10.3** (continued)

Name	Value	Unit
s_scrap_m	s_scrap_v*7.85e-6	

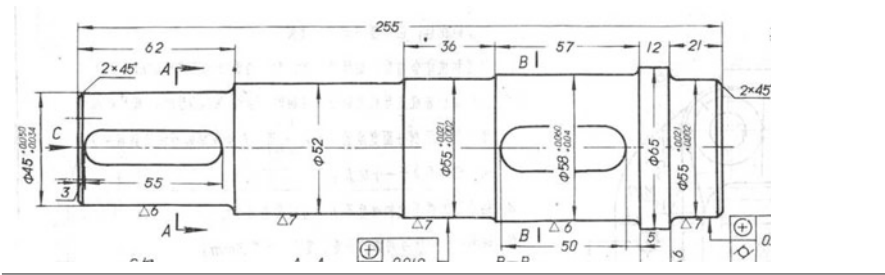

The gear is shown Fig. 10.4. Material of blank is the same as the high speed shaft. Mass of material used for blank is a calculated parameter named  $b_m$ . The  $b_m$  is obtained by  $b_v$  multiples density of the material, which is same as the high speed shaft. The  $b_v$  is the volume of a cylinder metal blank, which is calculated from input parameters through formula 10.5 shows below and in Table 10.4.

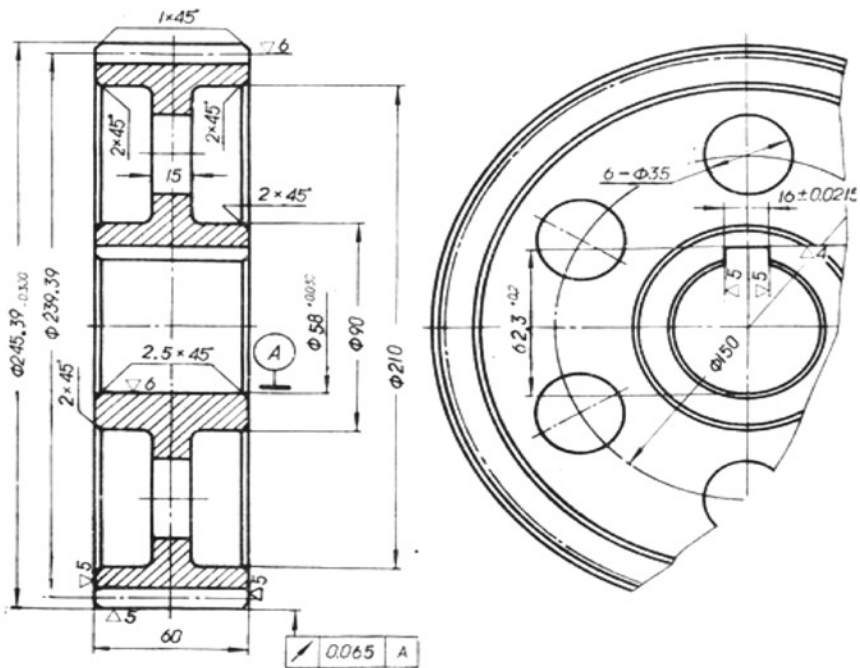

**Fig. 10.4** Gear (Gong et al. 1981)

**Table 10.4** Gear modelling parameters

Name	Value	Unit
Gear		
<i>Materials/assemblies</i>		
Steel, low-alloyed, at plant/RER U	b_m	kg
<i>Processes</i>		
Turning, steel, conventional, average/RER U	scrap_m-1	kg
Milling, steel, average/RER U	1	kg
Human labour	1	hr
<i>Input parameters</i>		
b_l	60	mm
b_d	237	mm
h_d	35	mm
h_a	6	mm
h_l	15	mm
r_d1	210	mm
r_d2	90	mm
r_l	45	mm
ch_d	58	mm
ch_l	60	mm
<i>Calculated parameters</i>		
b_v	$\pi/4 * b_d^2 * b_l$	
h_v	$\pi/4 * h_d^2 * h_l * h_a$	
r_v	$\pi/4 * (r_d2 - r_d1)^2 * r_l$	
ch_v	$\pi/4 * ch_d^2 * ch_l$	
g_v	$b_v - (h_v + r_v + ch_v)$	
b_m	$b_v * 7.85e-6$	
g_m	$g_v * 7.85e-6$	
scrap_m	$b_m - g_m$	

$$b_v = \frac{\pi}{4} * b_d^2 * b_l \quad (10.5)$$

The input parameters include the length and diameter of the blank, b\_l, b\_d, amount, length and diameter of holes, h\_a, h\_l, h\_d, two diameters and depth of the ring groove, r\_d1, r\_d2, r\_l, length and diameter of centre hole, ch\_l, ch\_d. Calculated parameters include the volume and mass of the blank and the gear, and the volume of holes, ring groove, and centre hole, h\_v, r\_v, ch\_v. which are calculated from input parameters through formula 10.6, 10.7 and 10.8.

$$h_v = \frac{\pi}{4} * h_d^2 * h_l * h_a \quad (10.6)$$

$$r_v = \frac{\pi}{4} \times (r_{d2} - r_{d1})^2 \times r_l \tag{10.7}$$

$$r_v = \frac{\pi}{4} \times (r_{d2} - r_d)^2 \times r_l \tag{10.8}$$

$$g_v = b_v - (h_v + r_v + ch_v) \tag{10.9}$$

And then, the volume of gear,  $g_v$  is calculated by the volume of the blank minus the sum of the volume of the holes, ring groove, and centre hole. The formula 10.9 is shown above. Then, the scrap cut off during the process of the gear manufacture is obtained.  $scrap_m$  is the mass of the scrap which is equal to the difference between that of the blank and that of the gear.

Case base is the base of the gearbox as shown in Fig. 10.5. Material used is cast iron. Mass of material used is a calculated parameter  $cb_m$ – $bec_m$ , which is the difference from mass of case base and mass of the holes cut off for assembling bearing end caps. They are all calculated from input parameters below as Table 10.5. The  $cb_m$  is obtained by  $cb_v$  multiples density of the material, which is estimated as  $7.125e-6 \text{ kg/mm}^3$ . The density is valued by the average value of the range of density from  $7.05e-6$  to  $7.2e-6 \text{ kg/mm}^3$ . The  $cb_v$  is the volume used to make cast iron. The formula to calculate the volume is shown below and in Table 10.5. The volume is equal to the difference from the cube outside to the cube inside of the case.

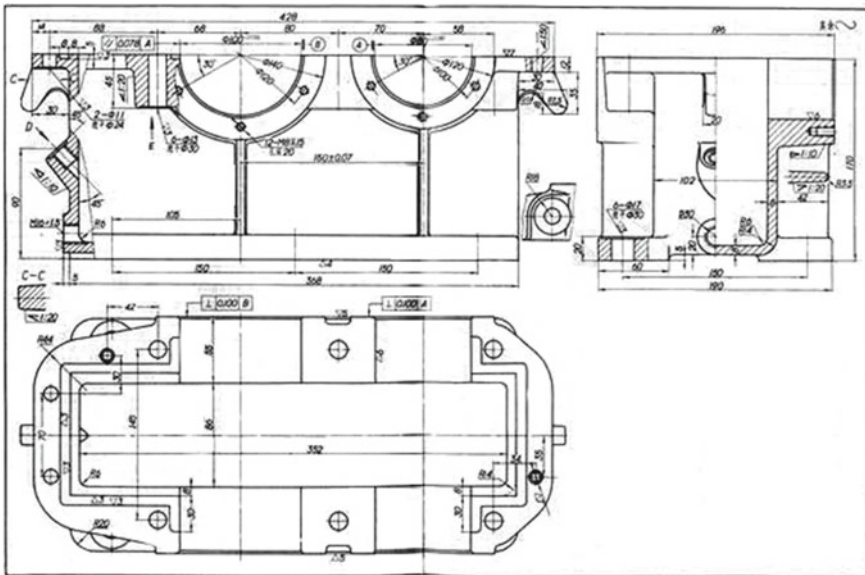

Fig. 10.5 Case base (Gong et al. 1981)



**Table 10.5** Case base modelling parameters

Name	Value	Unit
Case base		
<i>Materials/assemblies</i>		
Cast iron, at plant/RER U	cb_m-bec_m	kg
<i>Processes</i>		
Drilling, conventional, cast iron/RER U	hole_m	kg
Heat treatment, hot impact extrusion, steel/RER U	cb_m-bec_m	kg
Turning, cast iron, conventional, average/RER U	1	kg
Human labour	2	hr
<i>Input parameters</i>		
cb_l	428	mm
cb_w	190	mm
cb_h	170	mm
cb_t	8	mm
11	15	mm
12	20	mm
13	25	mm
14	35	mm
15	100	mm
sbec_d	80	mm
lbec_d	100	mm
<i>Calculated parameters</i>		
cb_v	$cb_l * cb_w * cb_h - (cb_l - cb_t) * (cb_w - cb_t) * (cb_h - cb_t)$	
cb_m	$cb_v * 7.125e-6$	
hole_v	$\pi/4 * 6^2 * (12 * 2 + 11 * 12) + \pi/4 * 8^2 * 24 * 13 + \pi/4 * 10^2 * 14 * 3 + \pi/4 * 12^2 * 15 * 6$	
hole_m	$hole_v * 7.125e-6$	
bec_v	$\pi/4 * cb_t * (sbec_d^2 + lbec_d^2)$	
bec_m	$bec_v * 7.125e-6$	

$$cb_v = cb_l \times cb_w \times cb_h - (cb_lcb_t) \times (cb_w - cb_t) \times (cb_h - cb_t) \quad (10.10)$$

The input parameters include the length,  $cb_l$ , width,  $cb_w$ , height,  $cb_h$ , and thickness,  $cb_t$ , of the case base, and five different lengths of bolts,  $l1$ ,  $l2$ ,  $l3$ ,  $l4$ ,  $l5$ , which are assembled in the case to tighten the case base and case cover. For convenient calculation, all the bolts are calculated with the case base but not case cover. Two diameters of two holes for assembling bearing end caps,  $sbec_d$ ,  $lbec_d$ , are also included in the input parameters. Calculated parameters include the volume and mass of the case base, all the holes for assembling the bolts,  $hole_v$ ,  $hole_m$ , and bearing end caps,  $bec_v$ ,  $bec_m$ . They are all calculated from input parameters. The  $hole_v$  and  $bec_v$  is calculated from formula shown below.

$$hole_v = \frac{\pi}{4} \times 6^2 \times (l2 \times 2 + l1 \times 12) + \frac{\pi}{4} \times 8^2 \times 24 \times l3 + \frac{\pi}{4} \times 10^2 \times l4 \times 3 + \frac{\pi}{4} \times 12^2 \times l5 \times 6 \quad (10.11)$$

$$bec_v = \frac{\pi}{4} cc_t \times (sbec_d^2 + lbec_d^2) \quad (10.12)$$

During the process of case base manufacture, the mass of holes,  $hole_m$ , is processed by drilling. Before drilling holes, the case base should be processed by heat treatment. Turning is the finish process to plain the surface of the case base. The weight processed by turning is 1 kg. Human labour used for manufacture of case base is two hours.

The case cover is the cover of the gearbox as shown in Fig. 10.6. Material used is cast iron. Mass of material used is a calculated parameter  $cc_m - bec_m$ , which is the difference from mass of case cover and mass of the holes cut off for assembling bearing end caps. They are all calculated from input parameters below as Table 10.6. The  $cc_m$  is obtained by  $cc_v$  multiples density of the material, which is estimated as  $7.125e-6 \text{ kg/mm}^3$ . The density is valued by the average value of the range of density from  $7.05e-6$  to  $7.2e-6 \text{ kg/mm}^3$ . The  $cc_v$  is the volume used to make cast iron. The formula to calculate the volume shows below and in Table 10.6. The volume is equal to the difference from the cube outside to the cube inside of the case.

$$cc_v = cc_l \times cc_w \times cc_h - (cc_l - cc_t) \times (cc_w - cc_t) \times (cc_h - cc_t) \quad (10.13)$$

The input parameters include the length,  $cc_l$ , width,  $cc_w$ , height,  $cc_h$ , and thickness,  $cc_t$ , of the case cover. For convenient calculation, all the bolts assembled in the case are calculated with the case base but not case cover. Two diameters of two holes for assembling bearing end caps,  $sbec_d$  and  $lbec_d$ , are also included in the input parameters. Calculated parameters include the volume and mass of the case base,  $cc_v$  and  $cc_m$ , all the holes for assembling the bolts and bearing end caps,  $bec_v$  and  $bec_m$ . They are all calculated from input parameters. The formula for calculate  $bec_v$  is same as that in case base.

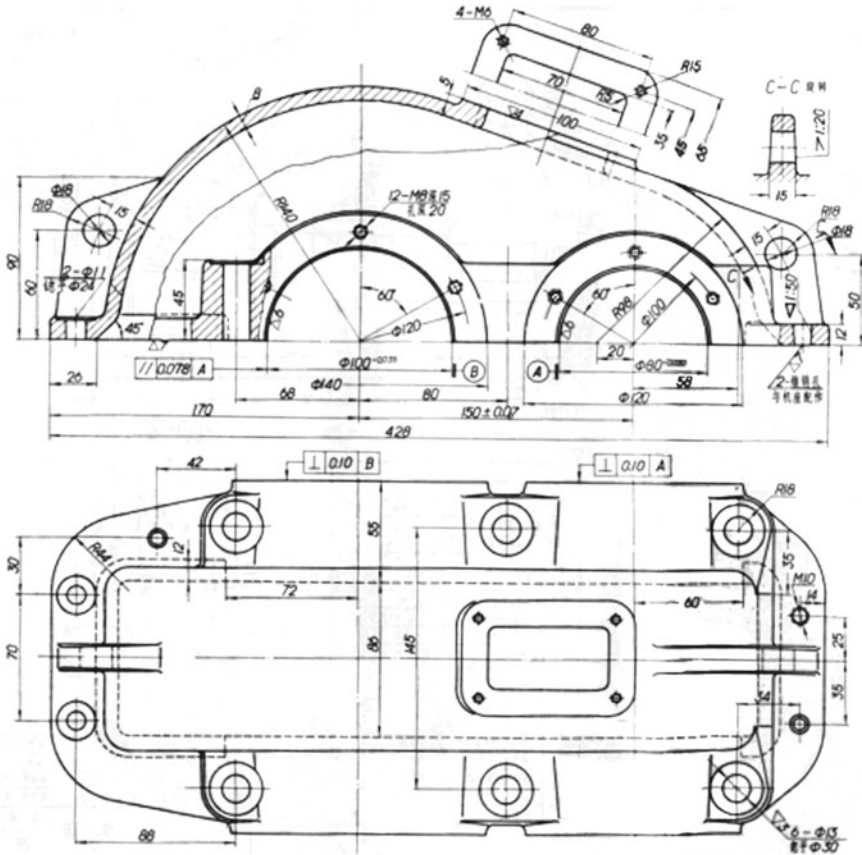

**Table 10.6** Case cover modelling parameters

Name	Value	Unit
Case cover		
<i>Materials/assemblies</i>		
Cast iron, at plant/RER U	cc_m- <i>bec_m</i>	kg
<i>Processes</i>		
Heat treatment, hot impact extrusion, steel/RER U	cc_m- <i>bec_m</i>	kg
Turning, cast iron, conventional, average/RER U	1	kg
Human labour	2	hr
<i>Input parameters</i>		
cc_l	428	mm
cc_w	196	mm
cc_h	140	mm
cc_t	8	mm
sbec_d	80	mm
lbec_d	100	mm
<i>Calculated parameters</i>		
cc_v	$cc_l * cc_w * cc_h - (cc_l - cc_t) * (cc_w - cc_t) * (cc_h - cc_t)$	mm <sup>3</sup>
cc_m	$cc_v * 7.125e-6$	
bec_v	$\pi/4 * cc_t * (sbec_d^2 + lbec_d^2)$	
bec_m	$bec_v * 7.125e-6$	

Input parameters include the length of the cylinder and the ring,  $l_1$  and  $l_2$ , and three, diameters of them,  $d_1$ ,  $d_2$ ,  $d_3$ . Calculated parameters include the volume and mass of the bearing end cap,  $v$  and  $m$ . They are all calculated from input parameters.

The input parameters include the length of the cylinder and the ring,  $l_1$  and  $l_2$ , and three, diameters of them,  $d_1$ ,  $d_2$ ,  $d_3$ . Calculated parameters include the volume and mass of the bearing end cap,  $v$  and  $m$ . They are all calculated from input parameters.

During the process of end cap manufacture, turning is the finish process to plain the surface of the end cap. The weight processed by turning is 0.1 kg. Human labour used for manufacture of end cap is half an hour. The modelling of low speed bearing end cap is similar as that of high speed bearing end cap.

The high speed shaft bearing is the bearing of high speed shaft as shown in Table 10.8. It is a 7208c angular contact ball bearing of GB/T 292-1994 standard. Material used is chromium steel. Mass of material used is a calculated parameter,  $m$ , which is calculated from volume of material used and the density of the chromium steel, which is estimated as  $8e-6$  kg/mm<sup>3</sup>. The density is valued by the average value

**Table 10.7** High speed bearing end cap modelling parameters

Name	Value	Unit
High speed bearing end cap		
<i>Materials/assemblies</i>		
Cast iron, at plant/RER U	m	kg
<i>Processes</i>		
Turning, cast iron, conventional, average/RER U	0.1	kg
Human labour	0.5	hr
<i>Input parameters</i>		
d1	120	mm
d2	80	mm
d3	60	mm
l1	10	mm
l2	50	mm
<i>Calculated parameters</i>		
v	$\pi/4*d1^2*l1+\pi/4*l2*(d2^2-d3^2)$	
m	$v*7.125e-6$	

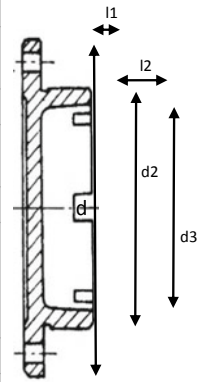

of the range of density from  $7.93e-6$  to  $8.09e-6$  kg/mm<sup>3</sup>. The v is the volume used to make chromium steel blank. The formula to calculate the volume shows below and in Table 10.8. The volume of blank is equal to the volume of whole cylinder.

$$v = \frac{\pi}{4} \times b \times (cd^2 - d^2) \tag{10.15}$$

The input parameters include four diameters, d, d2, cd, cd2, and the thickness of the bearing, b. Calculated parameters include the volume and mass of the blank, v and m. Based on the GB/T 292-1994 standard of 7208c angular contact ball bearing. The mass of the final bearing is about 0.37 kg.

During the process of bearing manufacture, milling is the finish process. The weight processed by milling is m-0.37-0.1. Which is equal to the mass of blank subtracts the mass of the bearing, 0.37, and mass processed by turning, 0.1 kg. Human labour used for manufacture of bearing is half an hour. The modelling of low speed shaft bearing is similar as that of high speed shaft bearing.

**Table 10.8** High speed shaft bearing modelling parameters

Name	Value	Unit
High speed shaft bearing		
<i>Materials/assemblies</i>		
Chromium steel 18/8, at plant/RER U	m	kg
<i>Processes</i>		
Milling, chromium steel, small parts/RER U	m-0.37-0.1	kg
Turning, chromium steel, conventional, average/RER U	0.1	kg
Human labour	0.5	hr
<i>Input parameters</i>		
d	40	mm
d2	52.8	mm
cd	80	mm
cd2	67.2	mm
b	18	mm
<i>Calculated parameters</i>		
v	$\pi/4*b*(cd^2-d^2)$	mm <sup>3</sup>
m	$v*8e-6$	

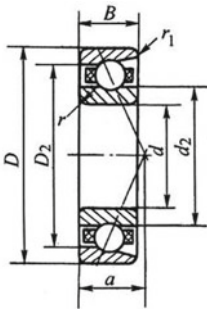

**10.2.1.2 Subassembly and Assembly Modelling**

As shown in Table 10.1, there are five subassemblies in the gearbox including sub-assembly of high speed shaft, subassembly of low speed shaft, case, bolts, and nuts. As Table 10.9 shows, each subassembly defines kind and amount of part and time spend of human labour for assembling parts together.

Modelling of subassembly in the SimaPro is to integrate all parts and time spent for assembling these parts together. For example, modelling of subassembly of bolts consists of two steps including add corresponding amounts of five different types of bolts into the subassembly and add time spend for assembling these bolts to the case. The subassembly of bolts consists of three m10\*35 bolts, six m12\*100 bolts,

**Table 10.9** Subassembly modelling

Subassembly	Part	Piece	Human labour
Subassembly of high speed shaft	High speed shaft	1	1 min
	High speed shaft bearing	2	
Subassembly of low speed shaft	Low speed shaft	1	2 min
	Low speed shaft bearing	2	
	Gear	1	
Case	Case base	1	1 min
	Case cover	1	
	High speed bearing end cap	2	
	Low speed bearing end cap	2	
Bolts	bolt m10*35	3	705 s
	bolt m12*100	6	
	bolt m8*25	24	
	bolt m6*20	2	
	bolt m6*15	12	
Nuts	nut m10	2	80 s
	nut m12	6	
Total		68	17 min 5 s

twenty-four m8\*25 bolts, 2 m6\*20 bolts, 12 m6\*15 bolts, and  $15 * (3 + 6 + 24 + 2 + 12) = 705$  s human labour.

Time spends of assembling one bolt and one nut are estimated as 15 and 10 s respectively. Other modelling of subassembly have similar processes. Totally, there are 68 parts in all of these subassemblies, and 17 min 5 s is spent to assemble these subassemblies.

The assembly is the gearbox. As Table 10.10 shows, modelling of assembly integrates all of the subassemblies together and add processes used during assembly. Assembly includes one for each subassembly modelling above. Processes used include 2 min human labour for assemble and 0.01 kWh electricity for lifting parts up.

## 10.2.2 Modelling of the Life Cycle

In the modelling of the gearbox life cycle, as shown in Table 10.11, the modelling phases include the gearbox, transport to retailer by van, disposal of the gearbox, and one additional life cycle of lubricating oils and greases. The transport is operated by a van with less than 3.5 ton weight load. Distance from factory to the retailer is 10 kilometres. The additional life cycle of lubricating oils and greases lasts one year. It will be replaced by new lubricating oils and greases once per year.

**Table 10.10** Assembly modelling

Name	Value	Unit
Original gearbox		
<i>Materials/assemblies</i>		
Case	1	p
Subassembly of low speed shaft	1	p
Subassembly of high speed shaft	1	p
Bolts	1	p
Nuts	1	p
<i>Process</i>		
Human labour	2	min
Electricity, medium voltage, production GB, at grid/GB U	0.01	kWh

**Table 10.11** Life cycle modelling

Name	Value	Unit
Original gearbox life cycle		
<i>Assembly</i>		
Original gearbox	1	p
<i>Processes</i>		
Operation, van < 3, 5t/RER U	10	km
<i>Waste/disposal scenario</i>		
Disposal of original gearbox		

Disposal of original gearbox refers to the gearbox assembly. Two hours human labour during the disposal process is added into the disposal as well. The waste scenario is estimated as 100% disassembly of the gearbox.

The disassembly of the gearbox is referred to the assembly to set up connection between it to the assembly. One hour human labour is consumed during the process of disassembly of the gearbox. The separation of sub-assemblies is not considered for the original gearbox. All the waste for the original gearbox is treated by waste scenario for England. The waste scenario for England indicates waste flow for different type of waste in the end life of the product in England.

### 10.3 LCA Results Interpretation

After the modelling of the gearbox life cycle, hierarchist version of the ReCiPe method with normalisation value of world and the average weighting set are selected to assess the model.

The network results of LCIA are shown in Fig. 10.7. Yellow box in figure refers



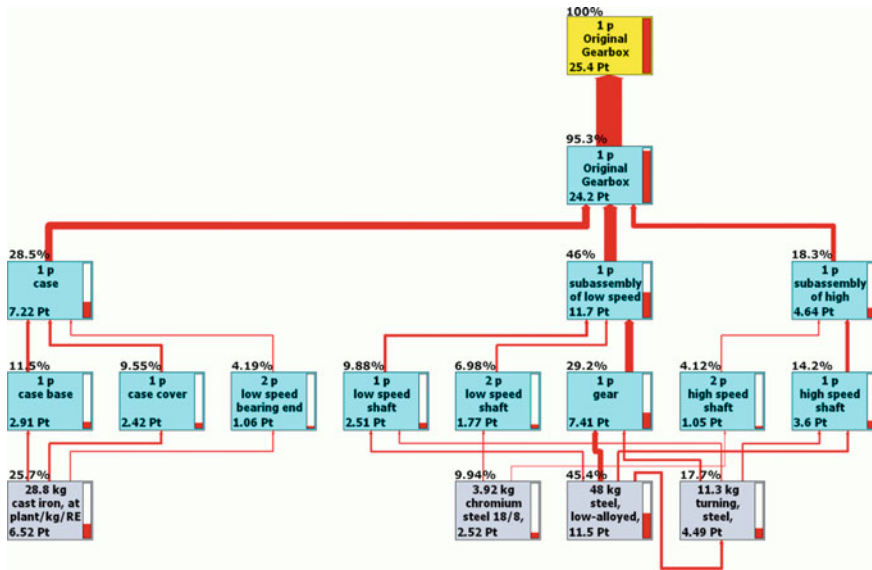

Fig. 10.7 Network of the gearbox LCIA results with 4% cut-off

to the life cycle of original gearbox. Light blue boxes refer to subassemblies and parts. The grey boxes refer to processes used. For better present of the network, 4% cut-off is applied. That means any impact less than 4% of all have been cut off and hide. Each process has a numerical reading of eco-indicator in left bottom and a red colour bar indicator diagram in right side. A larger reading and larger red bar represent a larger ecological impact that the process generated. Also, a wider arrow represents larger ecological impact flows in and out. Percentage of each box clearly indicates how much impact is shared by individual process, part, or subassembly. As the figure shows, cast iron, chromium steel, low-alloyed steel and turning process on steel has the most of ecological impact among all the processes and material used in the gearbox life cycle. They score 6.52Pt, 2.52Pt, 11.5Pt, and 4.49Pt and 25.5%, 9.86%, 45%, 17.6% of all ecological impact respectively. Obviously, the low-alloyed steel has the most impact. Nearly half impact is contributed by the extraction of the low-alloyed steel. The cast iron contributes to case base, case cover, and low speed bearing end. Actually, it also contributes to high speed bearing end but it is not displayed since the 4% cut-off. The chromium steel contributes to low speed shaft bearing and high speed shaft bearing. The low-alloyed steel contributes to low speed shaft, gear, and high speed shaft. And it also processed by turning besides it. The turning contributes to the gear, the low speed shaft, the high speed shaft. And it also contributes to the low-alloyed steel as mentioned before.

Focusing on parts, which are light blue boxes shown above the grey process boxes, the gear shares the most ecological impact among them. Which is 7.41Pt sharing 29.2% of all. The high speed shaft bearing and low speed bearing end have almost the least ecological impact, which are 1.05Pt. sharing 4.12% and 1.06Pt. sharing

4.19% respectively. The high speed shaft has the second high ecological impact of all these subassemblies, which is 3.6Pt. sharing 14.2%. The case base has the third high ecological impact of all these subassemblies, which is 2.91Pt. sharing 11.5%. The ecological impact of case cover and low speed shaft are almost the same, which are 2.42Pt. sharing 9.55% and 2.51Pt. sharing 9.88%. The two pieces of low speed shaft bearing has 1.77Pt. ecological impact, which shares 6.98%.

Focusing on subassemblies, the subassembly of low speed has the highest impact as 11.7Pt. sharing 46%. The main reason is the gear has the highest ecological impact. The case and the subassembly of high speed got second and third high ecological impact score, which are 7.22Pt. sharing 28.5% and 4.64Pt. sharing 18.3%.

The manufacture of gearbox assembly which is shown as the light blue box named original gearbox contains 95.3% ecological impact of all processes in the gearbox life cycle. That means transport, disposal of gearbox, disassembly of gearbox, additional life cycle of lubricating oils and greases have remaining 4.7% of ecological impact.

Figure 10.8 shows the damage assessment result in endpoint categories including human health, ecosystems, and resources. The original gearbox shares the largest ecological impact, which is shown as blue bar sharing from 93 to 94% of all three categories, among others. In resources category, the additional life cycle of lubricating oils and greases shares about 3%. Disposal of original gearbox shares about 1%. Operation of van shares about 2%. In human health category, operation of van shares about 1%, disposal of original gearbox shares about 4%. The additional life cycle of lubricating oils and greases shares less than 1%. In ecosystems category, the situation is similar as that in the human health but these three shares a little bit more than that in the human health.

Figure 10.9 shows normalisation assessment result which is normalised by different normalisation values of each endpoint category defined by ReCiPe endpoint method Hierarchist version. In world ReCiPe endpoint hierarchist version 1.04, the normalisation values are shown in Table 10.12. After normalisation, the result turns into the bar chart as shown in the Fig. 10.9. The ecological impact of human health

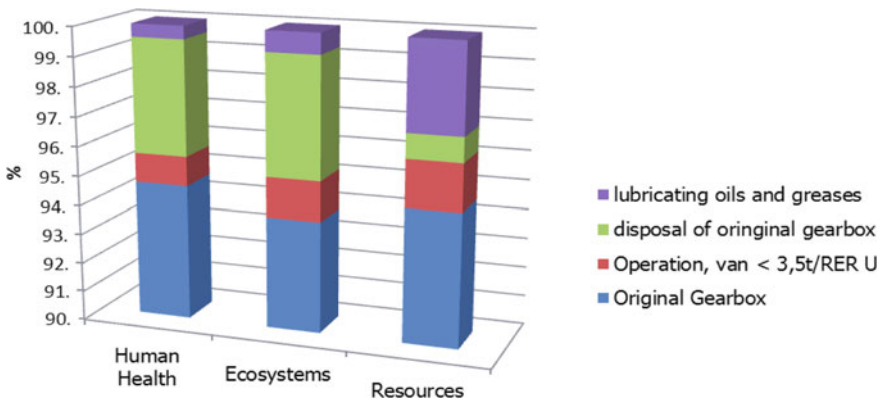
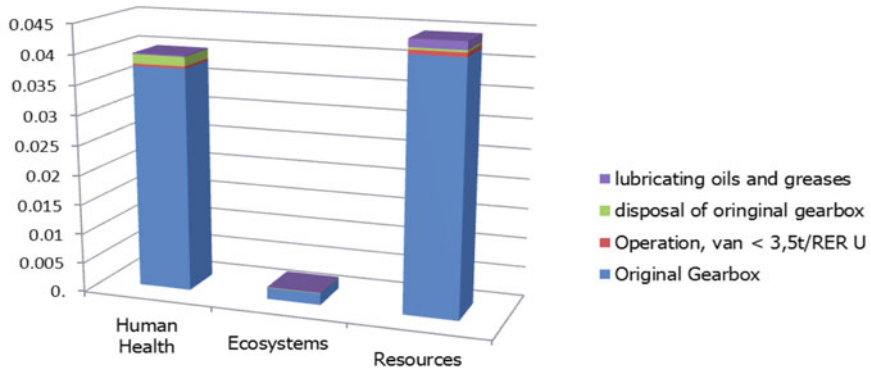

Fig. 10.8 Damage assessment result



**Fig. 10.9** Normalisation assessment result

**Table 10.12** Normalisation and weighting values defined in the ReCiPe endpoint world hierarchist version 1.04 [6]

Normalization-weighting set	World ReCiPe H/A
<i>Normalization</i>	
Human health	74.6
Ecosystems	1170
Resources	0.0000456
<i>Weighting</i>	
Human Health	400
Ecosystems	400
Resources	200

and resources is much higher than that of ecosystems. The original gearbox still shares the largest ecological impact in both categories. Disposal of original gearbox shares most of remaining ecological impact in human health. And the additional life cycle of lubricating oils and greases shares most of remaining ecological impact in resources. After weighting using the factor shown in the Table 10.12, resources reduces half of ecological impact as shown in Fig. 10.10. Because the weighting factor for resources is 200 and that of other two categories are 400.

Figure 10.11 shows a single score assessment result of each life cycle stage in endpoint categories. Original gearbox has the largest ecological impact, almost 25Pt in total. For original gearbox, ecological impact of human health shares the largest part, about 14Pt. ecological impact of resources shares the second large part, about 10Pt. ecological impact of ecosystems shares the remaining Pt., about 1Pt. Other three have a little ecological impact only.

Figure 10.12 shows bar chart and pie chart of process contribution, which indicate the most contributed processes or materials in the life cycle. 3% cut-off is applied to these two charts to make the presentation clearly. Pig iron and hard coal share 8% for each. They are the most contributed materials and get about 2Pt of ecological impact

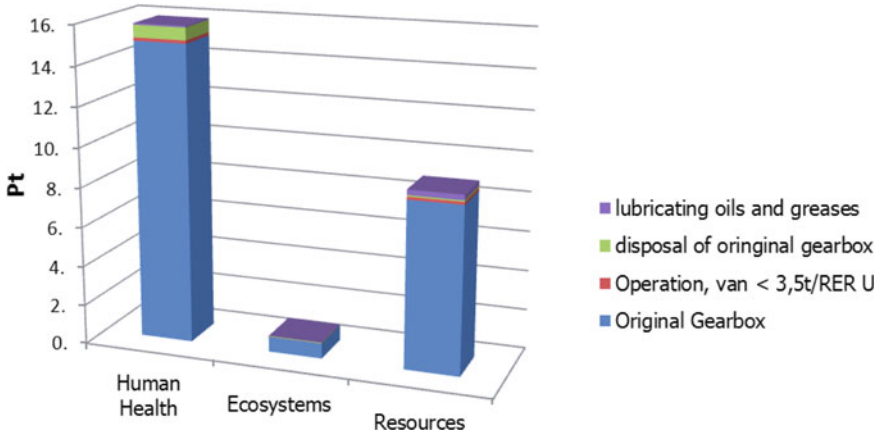

Fig. 10.10 Weighting assessment result

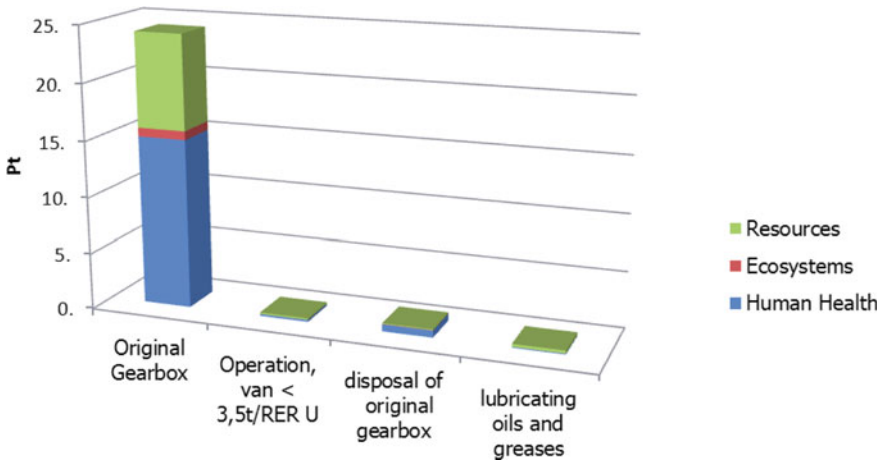

Fig. 10.11 Single score assessment result

for each. Iron ore with 46% Fe shares 7% as the third place. Hard coal shares 5% as the fourth place. Sinter of iron and cast iron are tied for the fifth place, sharing 3%. Remaining processes share other 66%.

Human labour contributes 0.684Pt and shares 2.7% of the ecological impact of original gearbox life cycle, which is 25.4Pt. In total, human labour involved  $6.8E4$  s' working time. The distribution of human labour in the whole gearbox life cycle shows in Fig. 10.13. The values below 8% have been cut off. Red bar in right side of each box indicates the ecological impact of human labour in every part or subassembly. Manufacture of gearbox shares 84.1% of all ecological impact of human labour. The disposal of gearbox shares remaining 15.9% of all. The subassembly of case

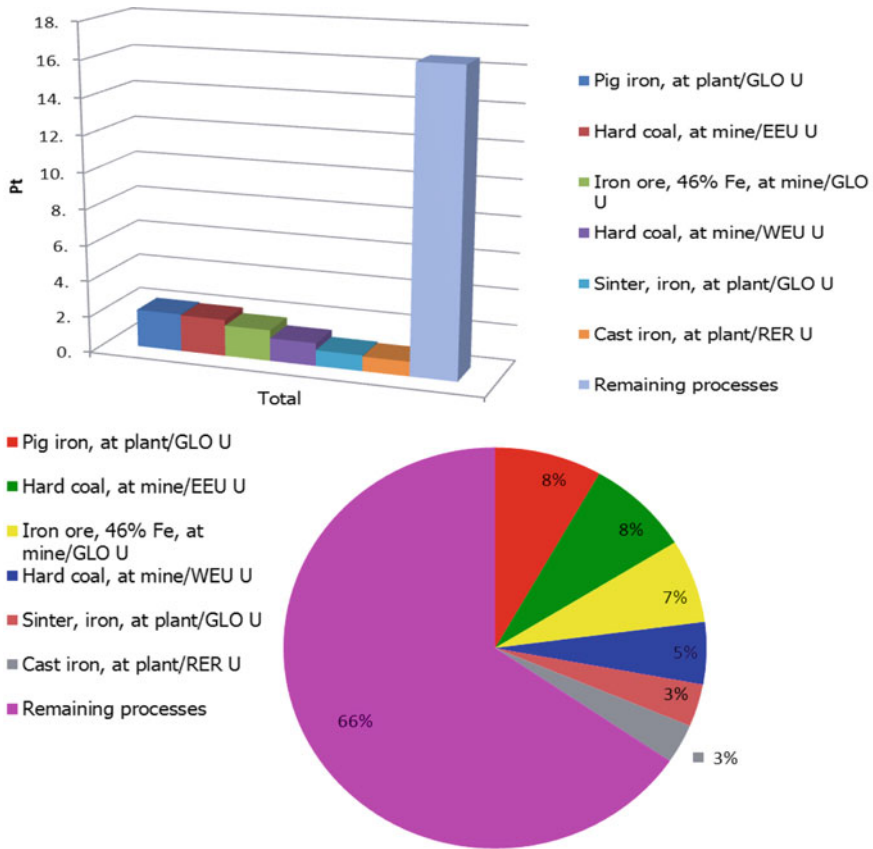

Fig. 10.12 Single score of process contribution

including case base and case cover, shares the most ecological impact, 31.8% of all subassemblies. Each of the case base and the case cover shares 10.6%. The subassembly of low speed shaft shares 16%. The subassembly of high speed shaft shares 10.7%. The subassembly of bolts shares 21.8%. 24 pieces of bolt m8\*25 shares 10.6%, which has the largest ecological impact of all bolts.

### 10.4 Analysis of Results and Proposal of Optimisation

After the interpretation of the LCIA results, there are several points should be highlighted below.

- Turning process on steel has the most of ecological impact among all the processes used in the gearbox life cycle.

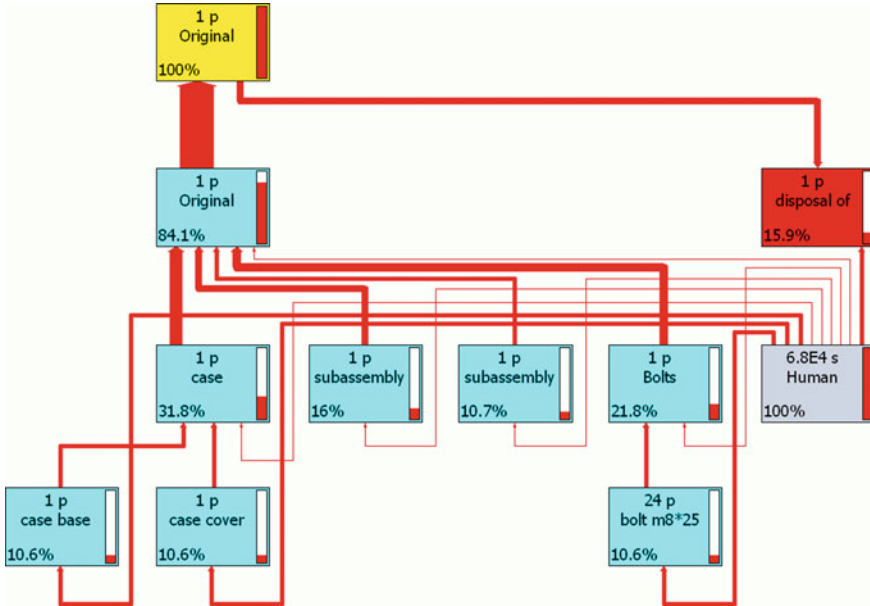

Fig. 10.13 Single process flow of human labour (8% cut-off)

- The low-alloyed steel has the most ecological impact among the all materials used in the gearbox life cycle. Nearly half of all, 45%.
- Most of the low-alloyed steel is used for manufacture of gear.
- The gear has the most ecological impact among all the parts, 29.2%.
- The subassembly of low speed has the highest ecological impact, because the gear within it has the highest ecological impact.
- The manufacture of gearbox assembly produces 95.3% ecological impact in the gearbox life cycle in this case.
- The disposal of gearbox has the second high ecological impact besides the manufacture of gearbox in the whole life cycle.
- To arrange the ecological impacts in endpoint categories in descending order are human health, resources, and ecosystems.
- The human labour contributes 0.684Pt and shares 2.7% of the ecological impact of original gearbox life cycle, which is 25.4Pt.

Based on the results obtained, redesign or optimisation should be carried out in order to reduce the gearbox’s ecological impact. Potential plans of optimisation may include:

- To extend the service life of gearbox
- To increase the recycle rate of used material
- Optimisation design of gearbox structure and life cycle with eco-constraints.

## 10.5 Conclusion

An LCA of industrial gearbox has been successfully conducted and reported in this paper. After structure analysis of the gearbox, three-tier method and parametric modelling are used to model the life cycle of the gearbox in SimaPro. The ecological impact of human labour is also involved in the LCA. A parametric approach is utilised in the modelling of gearbox life cycle. Based on the life cycle model of gearbox, the LCIA has been implemented using SimaPro with ReCiPe LCIA method. The results of LCIA consist of network, characterisation, damage assessment, normalisation, weighting, and single score. The results obtained illustrate the ecological impact of gearbox throughout its life cycle. In addition, the ecological impact of human labour is presented. Based on the analysis of results, optimisation plans are proposed at the end.

**Acknowledgements** This chapter is updated from its initial publication in the proceedings of the 14th IFToMM World Congress, Taipei, Taiwan. The authors are grateful for the permission given by the Congress organiser to use the original source of the paper for this book.

## References

- Baayen, H. (2000). Eco-indicator 99, manual for designers, a damage oriented method for life cycle impact.
- Gong, G., Pan, P., Chen, X., & Yan, L. (1981). *Examples of machine element and system designs for mechanical design course*. Harbin, China: Harbin Institute of Technology Press.
- Guinée, J. B., Gorrae, M., Heijungs, R., Huppes, G., Kleijn, R., Koning, A. de, Oers, L. van, Wegener Sleeswijk, A., Suh, S., Udo de Haes, H. A., Bruijn, H. de, Duin, R. van, and Huijbregts, M. A. J. (2001). *LCA—An operational guide to the ISO-standards—Part 1: LCA in perspective* (Final report, May 2001).
- ReCiPe. Quick introduction into ReCiPe LCIA methodology. Retrieved October 3, 2018, from <http://sites.google.com/site/lciarecipe/project-definition>.
- Su, D., & Ren, Z. (2011). Ecological impact assessment and eco-design of industrial gearboxes. *Key Engineering Materials*, 486(2011), 197–200.

# Chapter 11

## An Analysis and Evaluation of the Environmental Impacts of ‘Upstream’ Petroleum Operations



Ammar Irhoma, Daizhong Su, and Martin Higginson

**Abstract** Sustainability is increasingly considered an essential business function, but in Libya, petroleum companies are slow to address operational issues that could reduce environmental concerns. This study aims to evaluate the environmental impacts of upstream petroleum operations. The methods adopted in the study are a literature review, an Environmental Impact Assessment (EIA) study, fieldwork trials and 56 semi-structured interviews with Libyan personnel involved in upstream activities. The results of the study show that the main environmental impacts identified are atmospheric, aquatic or terrestrial and the most significant pollutants are found to be from the first category, mainly from engine exhausts, turbine emissions, gas flaring and venting. Major environmental degradations are identified in Libyan upstream operations and a number of recommendations suggested to minimise their effect, with the most important of these being the establishing of strict sustainability policies and regulations, and the implementation of an environmental management system.

**Keywords** Sustainability · Upstream petroleum industry · Libyan petroleum industry · Environmental impact

### 11.1 Introduction

Pressures from the international community including the United Nations are forcing oil-rich countries in the Middle East to improve their environmental record (UNEP 1997). In Libya, the petroleum industry is key to realising this, since it represents around 90% of the country’s revenue (Saleh 2006). Libya, as of June 2014, has a

---

A. Irhoma (✉) · D. Su · M. Higginson

School of Architecture, Design and the Built Environment, Advanced Design and Manufacturing Engineering Centre, Nottingham Trent University, Nottingham NG1 4BU, UK  
e-mail: [ammar.irhoma@gmail.com](mailto:ammar.irhoma@gmail.com)

D. Su

e-mail: [daizhong.su@ntu.ac.uk](mailto:daizhong.su@ntu.ac.uk)

M. Higginson

e-mail: [martin.higginson@ntu.ac.uk](mailto:martin.higginson@ntu.ac.uk)

© Springer Nature Switzerland AG 2020

D. Su (ed.), *Sustainable Product Development*,  
[https://doi.org/10.1007/978-3-030-39149-2\\_11](https://doi.org/10.1007/978-3-030-39149-2_11)



crude oil reserve of 48.5 billion barrels (BP a 2014), which is considered the largest in Africa. Additionally, Libya believes it has substantial undiscovered potential due to the fact that its land mass is mostly unexplored. Thus, it is vital that the Libyan Government focuses on the development of this sector. Sustainable Development (SD) was first mentioned by the World Commission on the Environment and Development (WCED) in 1987, through the Brundtland report. SD is defined as “development that meets the needs of the present generation without compromising the ability of future generations to meet their own needs” (WCED 1987, p. 6). Sustainability is considered as a global challenge for industrial sectors (Bukhari 2013) and therefore it requires a holistic move towards adopting sustainability principles and tools. Sustainability has three major and fundamental pillars; the environment, the economy and society. This study focuses on the environmental pillar. The concept of Environmental Sustainability (ES) is defined as “maintenance of natural capital” (Goodland 1995, p. 10). Goodland and Daly (1996) suggest that ES is a natural science concept which follows biophysical laws. ES is therefore concerned with protecting the environment from all types of pollution which have severe effects on the planet, such as global warming and other weather changes. It focuses on the reduction of environmental degradation and the use of natural resources.

The Petroleum industry is one of the major polluting industries in the world (Schweitzer 2010). It is the main source of all types of fossil fuels and is rated as the second highest polluting fuels after coal (Ali and Harvie 2013). International petroleum companies claim they have ES approaches which are implemented to reduce environmental impacts, such as the use of standardised environmental management systems like ISO 4001 and the Environmental Management and Audit Scheme (EMAS). Some scholars (e.g. Zaky 2013) would argue that petroleum companies are not “doing enough” towards the protection of the environment, though Schweitzer (2010) states that large international corporations like Shell, BP, and Exxon Mobil have made major strides in the right direction. By comparison, Agnaia (1997), Al-Drugi and Abdo (2012) state that Libyan petroleum companies do not currently have any schemes in place to tackle the problem. The purpose of this study is to identify and evaluate environmental impacts at the Libyan upstream oil and gas operations and recommend mitigation measures to minimise the identified impacts. The study provides the basis for future research to enable an appropriate EMAS specific to the Libyan petroleum sector to be realised. This type of study is the first of its kind conducted in the Libyan sector and contributes to the environmental sustainability literature in the context of the Libyan petroleum industry. The petroleum industry commonly consists of three major streams; the upstream, midstream and downstream operations. These streams are defined and the focus in this paper is on the upstream phase. Midstream and downstream phases are studied in future publications as a part of the author’s Ph.D. project.

The concept of sustainability came to the fore following the 1987 UN report, Our Common Future, by the Brundtland Commission (WCED 1987). It was reaffirmed as a goal by the 1992 UN Earth Summit’s Agenda 21 and again at the 2002 World Summit on Sustainable Development in Johannesburg. Sustainability was agreed as a top Millennium Development Goal in 2000 where it was stated “the overarching goal

is to define a global action agenda for sustainable development in the twenty first century and beyond.” Since then, numerous approaches and concepts have emerged in an attempt to improve ES performance, including Environmental Impact Assessment (EIA), Life Cycle Assessment (LCA) and Environmental Management Systems (EMS) i.e. ISO4001. It is noted that such approaches are increasingly implemented within international petroleum companies, but there is little evidence of similar realisation in Libyan petroleum companies (Irhoma et al. 2013). This study therefore uses an EIA methodology to assess the environmental impacts of the Libyan petroleum sector and offers a foundation for future implementation of these approaches. The Libyan petroleum sector is chosen for this study because it is a very substantial industry for both the Libyan economy and the European energy supply (Agnaiia 1997). Ali and Harvie (2013) state that the economy of Libya is mainly dependant on the revenues of the petroleum sector which is over 90% of the total Government income. In parallel, 71% of Libyan petroleum exports are transported to a very demanding market in Europe (European Commission 2010; EIA 2014). Another important factor is that, according to the Organisation of the Petroleum Exporting Countries (OPEC 2014), Libya has the largest petroleum reserve in Africa and the fifth largest in the world, which makes its petroleum sector a very important strategic supply for the long-term stability of European markets. Another reason for the study is the evident lack of literature, research and studies concerning the Libyan petroleum industry. As a Libyan himself, the author is well placed to conduct field trips and investigative research work related to the study and has established a network of contacts to aid this process. Although the petroleum sectors of other Middle Eastern and African countries have similar significance, Libya has a logistical advantage as it is located near to European shores. In addition, the high quality crude oil it produces (according to the American Petroleum institute ratings, it is classified as “light and sweet”) distinguishes it from other neighbouring petroleum sectors. According to Vandewalle (1998), upstream processes are the initial stages of oil and gas operations, which include exploration and offshore and onshore production. The midstream operations involve processing, refining and transportation and the downstream phase includes the activities for marketing, sales and delivery (Nooman and Curtis 2003). This study focused on upstream operations, since in Libya, these operations have not previously been investigated (Goodland 2013).

## 11.2 The Petroleum Industry in Libya

Libya post-1969 has seen considerable industrial and urban development. The Libyan petroleum sector, run by the National Oil Corporations (NOC), has received a substantial amount of this development. There has been interest in reducing the environmental impacts associated with petroleum operations (Green Oil and Akakus 2008) since the discovery of oil and gas in Libya. In both the developed and non-developed world, studies such as (Hu et al. 2013; Gilbuena et al. 2013; Bruhn-Tysk and Eklund 2002), have attempted to propose solutions to minimise associated impacts, but all

of these studies concluded that the identification of impacts and proposed mitigation measures require specific study of the site/project or planet and there is no conclusive solution to support the recommendations. For instance, Bayagbon (2011) recommended creating regulatory bodies tasked directly from the government to oversee the environmental performance at upstream oil and gas operations. Goodland (2013) in his book “Libya: the urgent transition to Environmental Sustainability” states that the petroleum sector struggles from various major environmental degradations and that there is a significant lack of research studies within the Libyan region. Irhoma et al. (2013) agree and suggest more research in the sector would support decision making and provide more considered solutions to make the sector more environmentally responsible. There are some Libyan studies in the field of environmental sustainability including (Bindra et al. 2014; Mohamed et al. 2013; Al-Drugi and Abdo 2012; Goodland 2013; Saleh 2006) and a few general quality improvement studies also exist such as Abusa (2011), but these are not specific to the petroleum sector. There is a clear gap in environmental sustainability research and a significant need for detailed studies to assist the decision-making process. According to Irhoma et al. (2013) the Libyan petroleum industry faces various challenges to implement modern concepts of SD and EMSs. In particular, it was found that leadership and management barriers along with resource issues (human, technical and financial) were the most significant. External political barriers of organisational culture and change were also major hindrances and Irhoma et al. (2013) propose a number of recommendations to enhance employee engagements and compliance with regulations, such as improved management structures and the use of strict policy and legislation, technical support, training and continued improvement approaches, which will all enhance the performance of the oil companies.

The Libyan petroleum sector consist of various large, medium and small companies, which are run by the state owned National Oil Corporation (NOC). The sector includes fully owned national Libyan companies, joint venture companies and other international companies holding exploration and production sharing agreements (EPSA) as well as education and training institutions. Figure 11.1 illustrates the major institutions which comprise the Libyan petroleum sector.

This study focuses on the early stages of oil operations (exploration and production). Whilst there are upstream petroleum operations in the east of Libya, mainly in Sirte basin and Sidra, the study was conducted in the Murzuq basin area in the west where most oil fields are based. Concentrating field trips to this area also helped with time and cost constraints. The Murzuq basin is located in the south west of Libya about 500 miles south of the capital city Tripoli. There are three oil fields in the Murzuq desert visited by the author between February 2013 and June 2013. These are El Sharara oil field owned and managed by the Spanish Repsol Oil Operations Company and El Feel and Al Wafa Oil fields which are both run by Melitah Oil and Gas B. V.

The El Sharara oil field was discovered in the 1980’s (NOC 2014). El Feel oil field (which is also called the elephant field) was discovered in 1997 by both the British company LASMO and the Italian ENI oil company. Later, LASMO was purchased by ENI. ENI operating in Libya changed its branch name to Melitah Oil

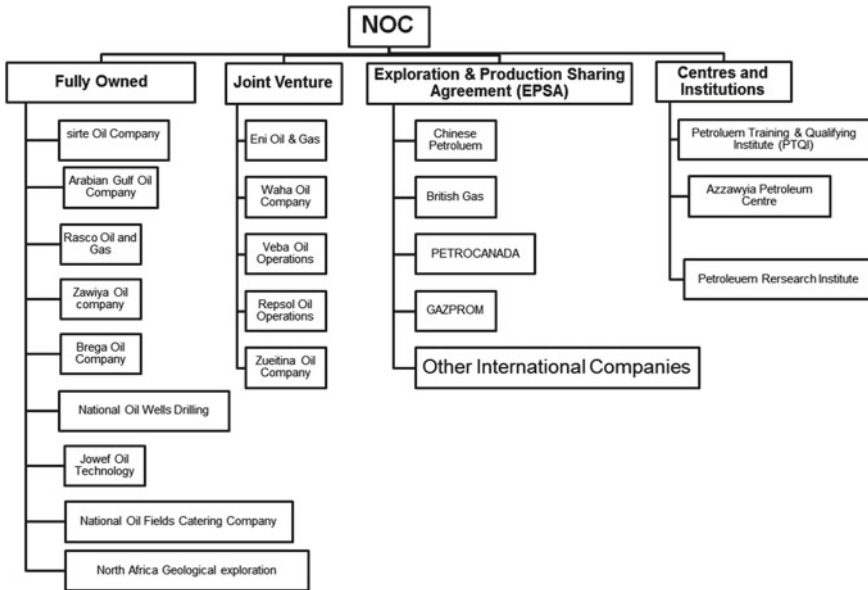
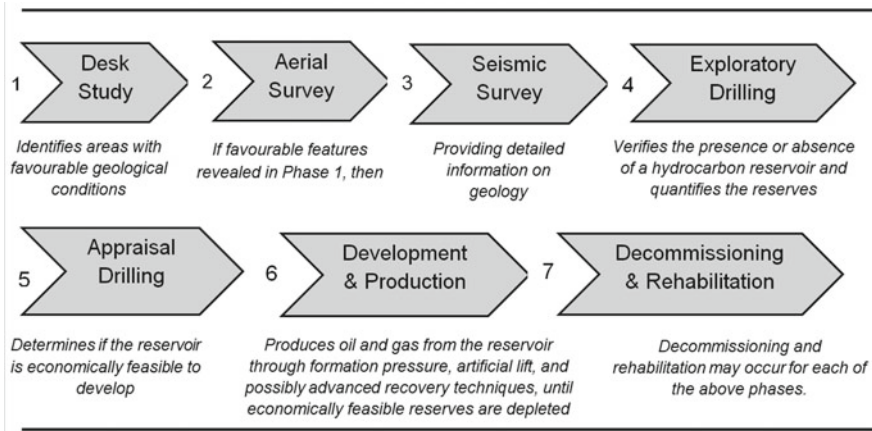

Fig. 11.1 Libyan Petroleum Industry companies (Source NOC 2014)

and Gas B. V and is the company which owns and runs the field in a joint venture agreement with the NOC. Al Wafa oil field was discovered by Shell in 1964 (Melitah Oil and Gas B. V 2014). Although joint venture companies run these oil fields, they represent a valid sample size of the Libyan upstream petroleum operations. Libyan petroleum companies run by the NOC share very similar management and organisational structures, which suggests the findings here should also be typical for other Libyan petroleum companies. None of the fully owned Libyan companies are involved with the upstream petroleum operations in the western region of Libya, they are mainly involved in midstream and downstream operations such as Azzawya oil refinery company and Brega oil company. According to the NOC (2014) EPSA operation companies are not involved in the production, but are more used for the discovery of petroleum reservoirs.

Nooman and Curtis (2003) clarify the major activities of the upstream oil and gas operations, which is highlighted in Fig. 11.2. The first activity is exploration (seismic survey). The seismic survey is used after the desk study and aerial survey. The seismic study provides more details on the geology of the area. The hydrocarbons are searched within water bodies and rocks, with geological maps studied to locate the sedimentary basin. Aerial photographs are taken to identify promising areas of hydrocarbons like vaults and anticlines (Ikein 1990). Major wastes are recognised at this stage, which can be categorised as explosive, non-biodegradable flammable and non-flammable.



**Fig. 11.2** The sequence of the upstream oil operations

The second activity is the exploratory drilling, which is informed by the seismic survey. This activity confirms the existence of hydrocarbons and estimates the internal pressure of the reservoir; it is then followed by appraisal drilling, which assesses the economic feasibility of the reservoir. Darling (2005) suggests that major environmental impacts are created at this phase mainly through wastes such as oil spills, drilling mud, cuttings, cement waste, chemical wastes, construction materials, and non-burnable waste scrap metals. The final stage of the upstream phase is development and production. This occurs if feasible amounts of hydrocarbon is confirmed in the prior stages and it includes the drilling of additional wells to optimise production and the construction of other facilities to form the oil field. Bayagbon (2011) argues that with all the previous environmental issues, emissions are continuously generated in the atmosphere from flaring, venting and exhausts from engines and machines. It is clear that each barrel of oil is pumped along with several barrels of environmental issues and it is important to understand the classifications of these impacts.

### 11.3 Classification of Environmental Impacts

The United Nations Environmental Program report (UNEP 1997) classified environmental impacts associated with petroleum industry operations into a set of categories. These classifications are further confirmed by Bayagbon (2011) and Bukhari (2013) and are discussed below.

- *Human, socio-economic and cultural impacts*

Upstream petroleum operations are likely to cause economic, social and cultural changes. Major impacts include: (1) land use patterns such as agriculture, land-take and exclusion; (2) local population level increase and immigration due to

increased access and opportunities; and (3) availability of, and access to, goods and services such as housing, education, healthcare, water, fuel and electricity brought to the region. Offshore oil fields in Libya are in the desert where population is very low and public facilities are limited. It should be noted that Upstream petroleum operations can have positive changes, such as improved infrastructure, health care, education, water supply and other social benefits to local rural communities (Bindra et al. 2014). There is no direct positive contribution, however, to the communities in rural areas; it is hard to find any facilities built for locals and it is essential oil companies start to consider social environmental sustainability.

- *Atmospheric impacts*

Atmospheric impacts are all air emissions. Activities at the stage of exploration and production must take account of work procedures and technologies to minimise emissions. Climate change and ozone layer depletion are the key consequences of atmospheric impacts which can be defined as (1) flaring and venting; (2) exhausts of fossil fuels from diesel engines and gas turbines; and (3) losses from process equipment, tankage and loading operations. These emissions include Green House Gases (GHGs).

- *Aquatic impacts*

Major aquatic impact from upstream operations include: drilling fluids, chemicals of well treatment, cooling water, domestic wastes, sanitary/sewerage and spills/leakages.

- *Terrestrial impacts*

These are the indirect impacts to soils that arise from physical disturbance as a result of construction or contamination from spillage, leakage or solid waste disposal.

- *Potential emergencies*

Awareness of potential emergencies should be of paramount importance in petroleum operations and are considered as environmental impacts. Sufficient measures need to be in place to deal with incidents affecting the environment, people and property, which might include: (1) spillage of fuel, oil, gas, hazardous materials and chemicals; (2) blowout of oil and gas wells; (3) explosions and fires; (4) unplanned shutdown events; and (5) natural disasters including earthquakes, floods, lightning and wars.

Figure 11.3 shows the typical impacts of the upstream operations.

## 11.4 Research Methods

A combination of research methods were utilised to achieve reliable findings. These methods include a literature review, EIA, semi-structured interviews and field trips. The EIA was conducted to assess various impacts at the project location (Murzuq

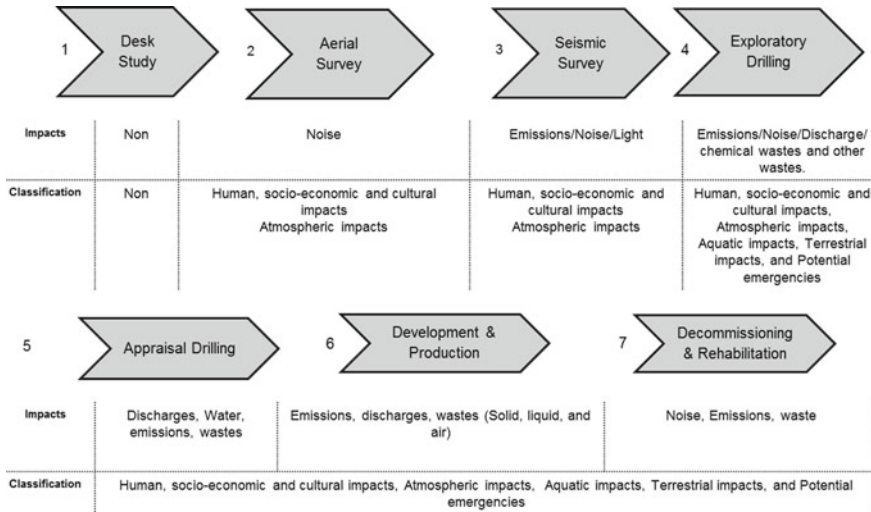

**Fig. 11.3** Environmental impacts at upstream operations

basin) and to provide a guide to the major sources of impacts and potential mitigation measures. The use of EIA highlights specific sources of impacts and their severity based on the EIA UNEP methodology approach by Abaza et al. (2004). In addition to this analysis, 56 semi-structured interviews were conducted to develop a better understanding of the environmental issues in petroleum companies. The interviews were conducted with representatives, engineers, senior managers, environmentalists and stakeholders involved at the upstream petroleum operations, to allow a diverse sample of data and opinions for evaluation (Table 11.1). Interviews allowed the researcher to gain in depth information about the subject under study and to understand the views of upstream petroleum personnel. The interviews were used to further investigate the environmental impacts and assess how they could be minimised from the interviewee perspective. The findings helped validate the EIA results and provide more reliable conclusions and recommendations. In addition to these techniques, documentary data including unpublished reports mainly from the National Oil Corporation (NOC) have been analysed. Two visits to Libya in February and July 2013 were of value to the author. He visited El Feel Oil Field, El Sharara Oil Field, Al Wafa Field and Azzawya Oil refinery. The fieldwork included observation of all field operations, major production plants, pumping stations, treatment, supply

**Table 11.1** Degree of control (Co)

Degree of control	Value
Not controlled aspect	5
Partially controlled aspect	3
Controlled aspect	1

systems and storage systems. These fields represent all of the upstream operations in the west of Libya. Azzawya oil refinery represents the importer, processor and exporter of crude oil from these three oil fields. The author conducted this study as a part of his PhD research project, which included use of an EIA methodology. Many practitioner such as (Bruhn-Tysk and Eklund 2002; BPb 2002; Abaza et al. 2004; Eidinov 2004; Gilbuena et al. 2013) claim that EIA is a successful tool to assess the environmental impacts and their risk implications for a specific project area, whereas other tools, such as Life Cycle Assessment (LCA) are more effective to analyse a specific product/process (Garg et al. 2013). The author aims to use LCA for Libyan petroleum products and processes for midstream operations (crude processing and refining) in future publications.

### ***11.4.1 Environmental Impact Assessment***

EIA is one of the major tools used to assist environmental analysis of a project of this nature. It evaluates the degradation that human activities can cause to the environment (Toro et al. 2013) and yields results that assist the decision making process (Wathern 1994). Wood (2003) and Toro et al. (2013) state that EIA is the technical key to incorporating environmental protection approaches and to avoiding the loss of natural resources (Wood 2003). EIA is widely implemented by various industries around the world, but (Ali and Harvie 2013) and Goodland (2013) claim that the Libyan petroleum sector lacks such studies. In order to assess the environmental situation at the upstream phase, EIA was conducted in the Libyan petroleum companies specific to the Murzuq basin project area (Southwest region- El Feel Oil field) and in compliance with the requirements of Libyan Law No 15 of 1371 (2003), NOC guidelines and best industry practice. This study is very significant in terms of originality as it is the first of its kind conducted in the sector in Libya. The EIA followed the UNEP methodology (Abaza et al. 2004) as well as taking account of the results of the fieldwork and reviews of unpublished reports from the upstream oil companies summarising the physical, biological, and socio-cultural/economic aspects of the oil field sites and surroundings. The assessment methodology as adopted from (Modak and Biswas 1999; BPb 2002; Eidinov 2004; Green Oil and Akakus 2008) is illustrated for quantifying the environmental impacts. The EIA assessment procedure uses the following formulas and calculations to rate the environmental risk. The environmental risk is the combination of the probability of a certain event occurring and the magnitude of its consequences (severity rate). For this procedure, the Rate of Environmental Risk (RER) is calculated as follows:

$$RER = P \times S \quad (11.1)$$



where  $P$  is the probability rate and  $S$  is the severity rate. Both  $P$  and  $S$  require additional calculations to establish the environmental risk. The quantification of the Probability Rate ( $P$ ) is dependent on two factors, (1) the degree of control on the aspect ( $Co$ ) and (2) the frequency of the impact or the aspect ( $Fr$ ), hence:

$$P = Co + Fr \tag{11.2}$$

To determine the degree of control, consideration is given to the existence or absence of: (a) written procedures and technical instructions; (b) contingency plans and training in case of contingency; (c) protection or physical barriers; (d) environmental objectives and targets related to the aspect; (e) competence (personnel developing the activities); (f) monitoring; and (g) a maintenance programme. Considering the above, the degree of control is scored according to the Table 11.1.

Frequency values of an environmental impact are shown in Table 11.2.

The assessment of the Severity Rate ( $S$ ) as shown in Eq. (11.1) requires the analysis of three issues which are: (1) the environment where the impact is affected (Environment,  $Env$ ); (2) the nature of the substance and its hazards (Nature,  $Na$ ); and (3) the magnitude of the impact (Magnitude,  $Ma$ ).

$$S = Env + Na + Ma \tag{11.3}$$

The Environment affected considers the sensitivity of the area impacted.

The following Table 11.3 shows the rating:

**Table 11.2** Frequency ( $Fr$ ) of impact

Frequency	Value
Very frequent	4
Frequent	3
Not frequent	2
Rare	1

**Table 11.3** The environment ( $Env$ )

Environment affected	Value
Ground water, ground or underground sweet water, agricultural land and human settlements	10
Protected areas and cultural heritage	8
Land for livestock activities	7
air, flora and fauna in a direct way	6
Land with no agricultural or livestock use, saline water	3
Land used for installations	1

**Table 11.4** Nature (*Na*) of the impact

Nature	Value
Dangerous	5
Not very dangerous	3
Not dangerous/there is no pollutant	0

**Table 11.5** Magnitude (*Ma*) of the impact

Magnitude	Value
Very high	10
High	7
Medium	5
Low	3
Negligible	1





The nature and hazards of a certain pollutant (*Na*) considers the physical and chemical characteristics of the pollutant. The ratings are illustrated in Table 11.4.

In order to establish the magnitude of the impact (*Ma*), it is necessary to measure the amount of resources consumed, the amount of wastes produced and the amount and concentration of the pollutant (Table 11.5).

Each impact is assessed using formulas (11.1), (11.2) and (11.3). The Rate of Environmental Risk (*RES*) calculated will show the amount of risk based on the evaluation of risk categories shown in Table 11.6. The risk categories are colour coded and hatched. This methodology was adopted from the general methodology of EIA and as used in EIA studies (BPb 2002; Kharaka and Otton 2003; Eidinov 2004).

The results of the EIA are shown in Table 11.7. The table includes the activity, the aspect and the rate of the environmental impact calculated using the above formulas. In addition, mitigation recommendations are given for each impact. The *RER* results are colour coded hatched based on the risk categories in Table 11.6.

**Table 11.6** Risk categories

<i>Risk categories</i>		
Probability Rate (P) × Severity Rate (S)	RES value	Sign
Low risk	<75	
Minor risk	75 to 84	
Moderate risk	85 to 99	
High risk	>100	

**Table 11.7** EIA results and recommendations

Activity	Aspects	Impacts	Probability Rate (P) $P = Co + Fr$			Severity Rate (S) $S = Env + Na + Ma$			(RER) = $P \times S$	
			Degree of Control (Co)	Frequency (Fr)	P	Environment (En)	Nature (Na)	Magnitude (Ma)		S
Operations Transportation	Soil	Oil and chemical spillages from vehicle accident or during fuelling may impact soils/water resources. Minor risk of leaks and small-scale spillages from engines and during refuelling. <b>Mitigation/Controls</b> (1) Spill Contingency Plan should be prepared; (2) clean up materials and equipment to be available on site; (3) ongoing environmental training to all associated with the project.	5	2	7	6	3	3	12	84
	Water	Minor oil spillage and leakage. Grease/oil may accumulate in ground water at low levels. <b>Mitigation/Controls</b> (1) Spill Contingency Plan should be prepared; (2) clean up materials and equipment to be available on site; (3) ongoing environmental training to all associated with the project.	5	2	7	3	5	3	11	77
	Air	Atmospheric emissions from diesel engines used in transport. Emissions mainly from diesel engine exhausts and some dust. <b>Mitigation/Controls</b> (1) Short transient.	5	2	7	6	3	3	12	84

(continued)

**Table 11.7** (continued)

<b>Operations Transportation</b>	Solid Wastes	Industrial inorganic wastes, hazardous materials will be generated but in small quantities. <b>Mitigation/Controls</b> (1) A detailed Waste Management Plan (WMP) must be implemented; (2) the WMP will take into account the existing reduction processes for treating or eliminating, partly or fully, all waste generated.	5	2	7	3	5	3	11	77
	Spillages	Oil spillages from accident or during gas oil tank refuelling may impact soils/water resources. <b>Mitigation/Controls</b> (1) Spill Contingency Plan should be prepared; (2) clean up materials and equipment to be available on site.	5	2	7	3	5	3	11	77
<b>Production and processing of crude oil and facilities</b>	Soil	Oil and chemical spillages from vehicle accident or during fuelling may impact soils/water resources. Minor risk of leaks and small-scale spillages from engines and during refuelling. <b>Mitigation/Controls</b> (1) Spill Contingency Plan; (2) clean up materials/equipment to be available on site; (3) on-going environmental training to all associated with the project.	5	2	7	6	3	4	12	84

(continued)

**Table 11.7** (continued)

<b>Production and processing of crude oil and facilities</b>	Biological Resources	Impact on terrestrial habitat. Possible damage to flora fauna and habitat. <b>Mitigation/Controls</b> (1) avoid destruction of vegetation; (2) restrict unnecessary vehicle movement in any sensitive vegetation areas; (3) each site must be scouted from an environmental perspective; (4) avoid locations with endangered species and habitats; (5) no intentional killing of local fauna (birds, mammals, reptiles, insects and spiders) unless there is threat to life; (6) decommissioning concept – all operations and facilities are designed to be easily dismantled. Renovation of tracks on completion; (7) Contractors and personnel used in the operation should receive environmental awareness training; (8) on-going environmental training to all associated with the project	5	4	9	3	3	3	9	81
		Noise and light may cause disturbance to life	5	4	9	5	2	3	10	90
	Air	Atmospheric emissions from power generation, flaring, venting and diesel engines used in transport. <b>Mitigation/Controls</b> (1) require comprehensive monitoring programme; (2) reduce SO <sub>2</sub> , H <sub>2</sub> S and other harmful emissions; (3) increase energy efficiency.	5	4	9	6	3	4	13	117

(continued)

Table 11.7 (continued)

<b>Production and processing of crude oil and facilities</b>	Solid Wastes	Industrial inorganic and organic wastes, hazardous materials generated in small quantities from maintenance, short term, infrequent and transient in nature. <b>Mitigation/Controls</b> (1) a detailed Waste Management Plan (WMP) must be implemented; (2) the WMP will take into account the existing reduction processes for treating or eliminating, partly or fully, all waste generated by the project.	5	4	9	3	5	3	11	99
	Noise and light	1. High transient noise and extraneous light levels close to the process plant could cause disturbance to people 2. Site is close to communities, little or no wildlife <b>Mitigation/Controls</b> (1) use adequate noise attenuation on engines and plant; (2) isolated location; (3) implement noise monitoring programme.	5	4	9	6	0	3	9	81
	Oil Spillages	Large scale catastrophic events may accumulate in soils water. <b>Mitigation/Controls</b> (1) detailed study for the site hydrology is recommended.	5	1	6	3	5	10	18	108
	Chemical Usage/Spillages	As with oil spillages, may accumulate in ground water <b>Mitigation/Controls</b> (1) chemical spill contingency plan to be implemented.	5	1	6	6	5	10	21	126

(continued)

**Table 11.7** (continued)

Emergency conditions and fire	Air	Minor H <sub>2</sub> S leak, Atmospheric emissions from burning hydrocarbons during fire. <b>Mitigation</b> (1) proper maintenance programme, personnel gas detector and escape masks	5	1	6	10	5	3	18	108
	Water	Fire water escapes to ground water with low level of contamination	5	1	6	6	5	3	14	84

Table 11.7 shows the calculations conducted for each impact using Eqs. (11.1), (11.2) and (11.3). The table also offers concise mitigation recommendations for each impact. These results reveal that water contamination with hydrocarbons is mainly due to leaks at the field facilities. Thorough evaluation of the extent and source of the pollution is recommended along with a review of the best technologies for soil and water remediation. The air analysis results were gained from unpublished studies at the company carried out to determine the extent of H<sub>2</sub>S, VOC, SO<sub>2</sub>, NO, NO<sub>2</sub>, CO and O<sub>3</sub> pollutants. It was noted that these results are based on instantaneous measurements, which are not comparable with international standards. A conclusion of the significance of these data can only be drawn following long term continuous measurements (six months to a year). This data is only indicative of the extent of the pollution; permanent monitoring stations are recommended. The water and air samples results will be used as a referenced for future monitoring. The EIA results show the level of risk of the environmental impacts identified. The high risk impacts were mainly air emissions (GHGs and hazardous H<sub>2</sub>S) and oil spillages. The extreme amount of gases exhausted from the heavy duty machinery and flaring were significant. Comprehensive monitoring programs are essential as are reduction of SO<sub>2</sub> and H<sub>2</sub>S emissions. The use of standardised environmental protection procedures are necessary to minimise spillages and the use of chemical spill contingency plans. Surprisingly, levels of noise and light were rated as a moderate risk along with industrial inorganic and organic wastes and hazardous materials. Although these represent small quantities from maintenance departments, consideration is still important. The remaining impacts were rated as minor risk and low risk.

#### 11.4.2 Interviews Findings

Following the identification of environmental impacts from the EIA, the views of the upstream petroleum personal and stakeholders on how to minimise these impacts

**Table 11.8** Overview of the interviews

Classification	Organisation	Code of interviewee	City	No of interviews
Petroleum Sector Policy Makers (PSPM)	PSPM (A)	A1, A2, ... A5	Tripoli	5
Azzawya Oil Company (AOC)	Azzawya Oil Company (B)	B1, B2, ... B5	Azzawya	5
Environment General Authority (EGA)	EGA (C)	C1 & C2	Tripoli	2
El Sharara Oil Field (ESOF)	ESOF (D)	D1, D2, ... D15	Murzuq Desert	15
El Feel Oil Field (EFOF)	EFOF (E)	E1, E2, ... E16	Murzuq Basin	16
Al Wafa Oil Field (AWOF)	AWOF (F)	F1, F2, ... F8	Ghadames Desert	8
Senior Managers (SM)	SM (G)	G1, G4, ... G4	From all the above	4
Total number of interviews				56

was considered. 56 Semi-structured interviews were conducted from a diverse sample. Table 11.8 shows a classification of the interviewees, with each interviewee categorised with a code based on his/her organisation and location. Interviews were recorded and assessed using a qualitative analysis approach (thematic analysis). This type of analysis allows the discussion to be investigative. Open, semi-open and closed questions were used to allow interviewees to elaborate on their answers and provide further insights into the subject under study.

The interviewees were selected from different organisations who are directly and indirectly involved in the upstream petroleum operations. Three upstream petroleum companies which represent the fieldwork area (El Sharara oil field, El Feel oil field, and Al Wafa oil field) were considered along with one midstream company (Azzawya Oil Company), which represents the importer and exporter of the produced oil from the western region. Five interviews were conducted at the National Oil Corporation (NOC), which is the state owned administrator of the Libyan petroleum sector. Two interviews were conducted with personnel from the Environmental General Authority (EGA). The EGA is the government monitoring body and watchdog that has direct relations with the petroleum sector. The sample of interviewees were carefully selected to gain a diverse, general understanding of the environmental issues from a variety of sources and levels of the workforce and to achieve more realistic, reliable results.



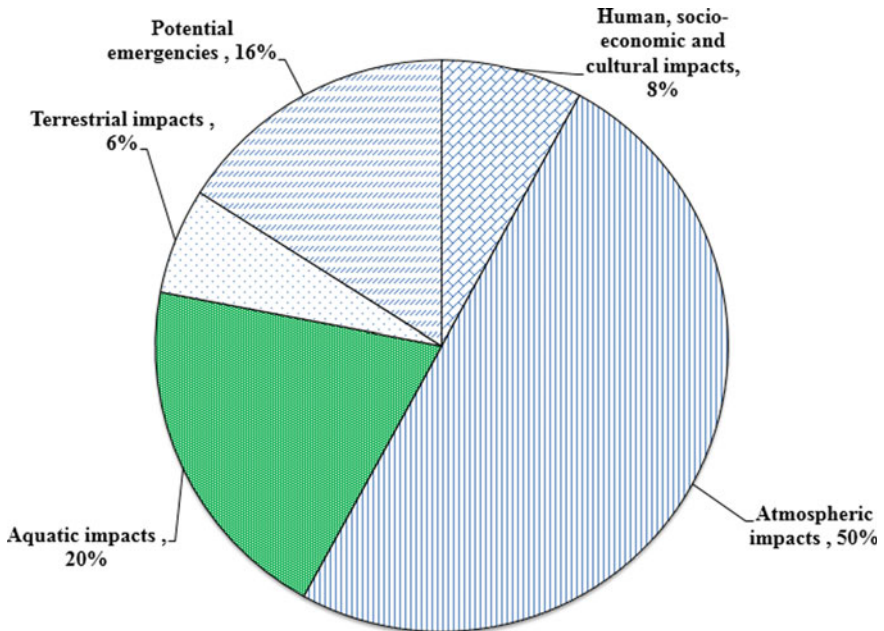

**Fig. 11.4** Environmental issues at upstream oil and gas operations based on interviewee responses

As shown in Fig. 11.4, the results imply that around 50% of the total impacts are atmospheric with around 20% aquatic. These categories are further broken down as shown in Fig. 11.5. Interviewees further classified each category of the impacts. For example, atmospheric impacts were split into two; emission from combustion of engines and turbines, and gas flaring and venting.

Interviewees were also asked to rate the environmental performance in their companies, yielding the breakdown in Table 11.9.

The results show there is a clear contradiction between the views of policy makers and senior managers compared to the rest of employees. This contradiction indicates either a lack of honesty from senior employees or a lack of awareness from lower level employees. However, a senior manager shed light stating that:

*....Terrible leadership and management is the cause of bad environmental performance at the petroleum sector, and most of senior managers will try to defend themselves knowing it is mainly their fault....[ESOFD7].* ESOFD7 is the code of the interviewee which refers to the Interviewee Company and number (see Table 11.8).

Interviewees were prompted to comment on the extent of the effort their companies gave to environmental protection, with results summarised in Table 11.10.

The majority of interviewees felt their company did not sufficiently support attempts to minimise environmental impacts. Those who responded positively referred specifically to the efforts directed towards Health and Safety (H&S) and potential emergencies. It is agreed that efforts regarding potential emergencies are

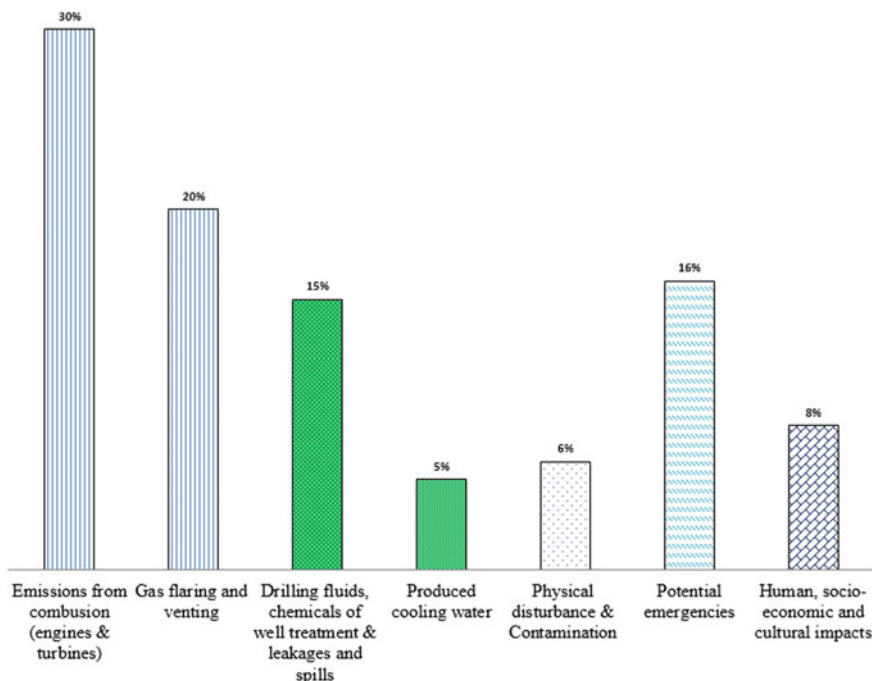

Fig. 11.5 Classifications of identified environmental impacts

Table 11.9 Company environmental performance

Interviewee company	Excellent	Moderate	Low
Petroleum Sector Policy Makers (PSPM)	30%	60%	10%
Azzawya Oil Company (AOC)	0%	10%	90%
Environment General Authority(EGA)	NA	NA	NA
El Sharara Oil Field (ESOF)	15%	50%	35%
El Feel Oil Field (EFOF)	10%	55%	35%
Al Wafa oil field (AWOF)	20%	40%	40%
Senior Managers (SM)	90%	10%	0

satisfactory, but that atmospheric and terrestrial impacts had never been considered by their companies. An interviewee from Azzawya Oil Company said:

....There are good practices regarding health and safety protection in my company, but there is no adequate consideration regarding the environment... [AOCB3].

Another senior manager from the EGA adds:

....There is a clear resistance and lack of motivation towards the implementation of voluntary environmental management systems, there is lack of compliance with essential basic requirements of environmental regulations rather than the volunteering EMSs...[EGAC1].

**Table 11.10** Companies environmental performance based on employee perception

Answers	Yes	No	I do not know
Petroleum Sector Policy Makers (PSPM)	40%	60%	0
Azzawya Oil Company (AOC)	20%	80%	0
Environment General Authority(EGA)	NA	NA	NA
El Sharara Oil Field (ESOF)	30%	70%	15%
El Feel Oil Field (EFOF)	26%	74%	0
Al Wafa Oil Field (AWOF)	20%	75%	5%
Senior Managers (SM)	45%	55%	0

From Al Wafa oil field a maintenance engineer stated that:

...One way to contribute to sustainable development and reduction of fossil fuels consumption by Libyan petroleum companies investment in renewable energy generation using solar and wind ...[WOFF2].

It was noted from another senior manager in the EGA that lack of supervision and environmental monitoring is one of the causes of the poor attitude of oil companies towards the environment. This demonstrates the key issue of leadership and management of Libyan upstream companies. A newly employed production engineer at El Sharara oil field stated that:

...Leadership and management issues of my company and the oil and gas sector in general is mainly associated with lack of effective management. Corruption from previous regime still exists in the sector and it is one of the key causes of unsustainable petroleum production...[ESOFD11].

As a part of the interview process, a question was asked concerning how environmental impacts at the upstream operations might be reduced. The question aimed to gain the views of interviewees based on their experience in the field. Table 11.11 shows the key repeated recommendations provided by interviewees. General assumptions have been made from the interviews with regards to potential solutions to a more environmentally-friendly and sustainable approach. The responses are taken

**Table 11.11** Recommendations to minimise environmental impacts

Recommendation	No of interviewees
Academic research to support decision making	50
Implementation of EMSs and sustainable development tools	47
Training and awareness on how environmental impacts could be minimised	42
Seek assistance from experienced international oil companies for managing environmental impacts	39
Establishing the environmental policies and regulations	34

from 56 interviewees and presented based on the frequency of comments. It is concluded that academic and scientific research is essential for decision making in their companies and was recommended by 50 interviewees. The implementing of modern approaches and environmental management systems was recommended by 47 interviewees. Environmental awareness and training was highly recommended along with seeking external specialist support and consultancy from experienced international companies. The establishment of strict environmental policies and regulation was also a major recommendation from the interviewees. These views are consistent with literature findings such as (Irhoma et al. 2013; Goodland 2013; Bindra et al. 2014).

A senior manager from the NOC stated:

...I believe it is very important to conduct scientific research studies to support decision making and produce empirical results to help make the right decisions for the sector improvements, research and development I think are extremely important....[SMG2].

Another interviewee stated:

...For oil fields, it is important to use new modern approaches of sustainability and environmental performance. I think it is our challenge to get such approaches implemented, and one way of making it easy is to use the experience of international experienced companies to assist in such projects...[AOCC3].

The implementation of sustainable development approaches and environmental management systems are very important to help improve environmental performance (Campos 2012) but there are essential requirements to provide the base for such tools to be easily implemented. These requirements were identified by Irhoma et al. (2013) in their study titled "Analysis of the Barriers to Environmental Management Systems Implementation in the Libyan Oil Industry". The study found that barriers are associated with leadership and management, resources (human, technical and financial resources) and political and external forces. It is important, therefore, that companies improve their management procedures before the implementation of EMS's.

Training and education were considered a key issue by most interviewees in the study, in addition to seeking advice from internationally experienced oil companies in technical matters. Establishing and regularly updating environmental policies and regulations was deemed a significant requirement. Most of the interviewees appreciated the importance of sustainable development methodologies and Environmental Management Systems implementation, with 95% referencing its importance.

A senior manager from the NOC stated that:

...all developed countries view sustainability and environmental management as a priority in their sectors, It is the time that we need to do so, especially in an important sector like petroleum sector....[PSPMA2].

### 11.4.3 *Political Changes*

The research work, including fieldwork visits, were conducted after the political changes in Libya. Libya witnessed 8 months of civil war, which led to significant changes and a total shutdown to the petroleum sector. Most of the data collected were gained after the changes, which allowed honest responses from interviewees that may have previously put their jobs at risk. This increased democracy and freedom to express opinions enhances the validity of the study results. Organisation culture has transformed since the changes in the political system of the country.

An employee from Al Feel oil field stated:

.... If you were questioning me the same questions before the revolution (17th Feb, 2011), I will simply refuse to participate in this study, or I will just say that everything is going well and fine, because of fear of consequences, but now, I am not scared from anyone, and I can tell exactly how I feel and think about the work and company..... [EFOFE6].

## 11.5 Discussion

The continual reliance on the petroleum sector for the country's revenue and economic stability is one of the important challenges Libyan policy makers face. Sustainable development is an essential concept to be developed and promoted in the Libyan petroleum sector. Similar to any other country, Libya needs to boost its economy, maintain and increase its sources of income and establish financial stability post war. With increasing pressures from the international community, the United Nations and other Non-Government Organisations (NGOs), the main sector in the country is required to address its environmental impacts within a strategic development plan. As stated by a policy maker from the NOC:

.... Petroleum developmental strategies must focus on the environmental dimension and should have a roadmap on how to enhance the overall environmental performance of the sector... [PSPMA5].

The significance of sustainable development is recognised by policy makers, however no actions appear to be taken on the ground. This might be due to the lack of effective strategy and legal compliance.

The results in this paper identify the major environmental impacts at the upstream oil and gas operations in the western region of Libya specifically in Murzuq desert. EIA was carried out to assess the major influences based on their risk category. The risk category calculated relies on the severity of the impact and the probability based rate of occurrence. Qualitative analysis using semi-structured interviewees compliment the findings of the EIA and assess the awareness and viewpoints of a carefully selected sample.

EIA results show the high risk of environmental impacts are those related to air emissions (combustion and flaring) and those that impact land and soil such

as spillages of chemical wastes. Other organic and inorganic waste were considered moderate risk, with noise and other terrestrial impacts minor rise. Underground water, noise and other Socio-economic and socio-cultural impacts were ranked as low, but not insignificant risk; studies should be conducted to evaluate reduction options. A major issue witnessed with all the upstream companies visited is the lack of environmental reporting and data-storing. This is clearly expected in an environment where there are no government monitoring procedures to force the companies to initiate environmental recording and reporting procedures. EIA recommends a spill contingency plan to be established with clean up materials and equipment being available on site along with on-going environmental training to all associated with the project. In addition, studies into soil remediation technologies along with the use of oil sludge disposal and recovery technologies for treatment purposes as advised by Hu et al. (2013) should be adopted. To minimise emissions, flaring gas recovery systems (GRS) are required at all field flaring stations. Companies should invest in carbon storage technologies and conduct a set of energy saving feasibility studies. These studies will allow simple and effective energy savings throughout the processes. Industrial inorganic wastes and hazardous materials were ranked as high risk, therefore a detailed waste management plan (WMP) must be developed and implemented. A comprehensive monitoring programme is recommended to improve air emissions along with technologies to minimise SO<sub>2</sub>, H<sub>2</sub>S, NO<sub>x</sub>. Further, increasing the energy efficiency of diesel engines and heavy duty machines is essential, which could be assisted by replacement of old machines with more advanced and environmental-friendly options. Leaks, spillage and other wastes were ranked as a minor risk.

Interview findings complement EIA results and offer an understanding of the environmental issues from a human perspective. Findings were generated which show the diversity of viewpoints and understanding from various interviewees from the Libyan upstream companies. This analysis concludes that the major environmental impacts are atmospheric associated with gas flaring, exhausts from diesel engines, turbines and other heavy duty machines. Another major concern relates to aquatic sources, which include contaminated water, drilling fluids, chemicals, leaks and spills. A number of key recommendations were received from the interviews which include the necessity of academic and scientific research studies to improve the performance of the Libyan petroleum sector, in addition to the implementation of International management standards and sustainability improvement concepts. Lack of strict sustainability policies and laws has contributed to the low environmental performance. It is important for the Libyan petroleum sector to seek external consultancy from international experienced and expert organisations in the field of sustainability and in parallel, raise sustainability awareness within the petroleum companies.

The results of this paper represent a novel attempt to classify and quantify the environmental impacts at the upstream petroleum industry, yet it has two limitations. The first is that the EIA conducted was implemented at a basic level and to a limited project area. Intensive EIA studies should be conducted to gain more comprehensive and in depth identification of impacts. Second, the study was mainly targeting the upstream operations of oil and gas companies in the western region of Libya; it did

not include similar in eastern regions. It is known, however, that Libyan petroleum companies run by the NOC share the same organisational and political structure and culture and therefore should share the same environmental issues.

## 11.6 Conclusion

The first of its kind, this study presents a novel contribution to identify the environmental impacts at Libyan petroleum companies' upstream operations. The major impacts are identified using a mixed methods approach including EIA, fieldwork and semi-structured interviews. Clear understanding of the environmental performance of the Libyan upstream companies was gained. The sector suffers from high environmental degradation and lack of effective environmental management. It was found from the EIA that Libyan petroleum upstream operations have various environmental impacts, which were categorised. The highest risk impacts are related to waste issues of soil, which include the large scale catastrophic events throughout the upstream phase, as well as industrial inorganic wastes and hazardous materials. However, these high risk, aquatic impacts represented only 20% of overall impacts. The majority of impacts were classified as atmospheric; 50% associated with gas flaring, venting and the exhausts of the heavy duty machines such as diesel engines and turbines. Atmospheric impacts were ranked with both high and minor risk. The high risk impacts were associated with dangerous gases from flaring and power generation such as SO<sub>2</sub>, H<sub>2</sub>S and NO<sub>x</sub>. Minor risk emissions were the rest of gases including CO<sub>2</sub>. Findings from this study revealed additional management and leadership issues, lack of sustainability awareness and lack of implemented standardised sustainability approaches in the sector.

It is recommended that:

- Waste management plans (WMP) and spill contingency plans (SCP) be conducted to identify practical and realistic ways of minimising waste, spills and leaks.
- Scientific studies are essential to examine and evaluate environmental issues such as in depth EIAs and life cycle assessment (LCA).
- Flaring gas recovery systems (GRS) should be installed at all flaring stations to minimise the amount of emissions.
- Environmental training and awareness programs within the upstream petroleum companies targeting employees at all levels.
- Implementing energy saving feasibility studies to all of the current power generation turbines and heavy duty machines to allow energy saving and efficiency increase.
- Oil sludge treatment such as sludge disposal technologies be conducted.
- Enhance leadership and effective supervision within the petroleum upstream companies by the integration of standardised sustainability approaches, such as ISO4001 and EMAS.

- Empower regulatory authorities and government organisations, such as the Environmental General Authority (EGA) to monitor environmental compliance.
- Establish strict policies and regulations toward sustainability.

**Acknowledgements** This chapter is updated from the following initial publication:

*Annmar Irhoma, Daizhong Su and Martin Higginson, 2016, 'Analysis and evaluation of the environmental impacts of upstream petroleum operations', International Journal of Manufacturing Technology and Management, Vol. 30, Nos. 1/2, pp 116–142.*

The authors are grateful for the permission from the publisher of the journal, Inderscience Enterprises Ltd, for using the initial source in this book.

## References

- Abaza, H., Bisset, R., & Sadler, B. (2004). *Environmental impact assessment and strategic environmental assessment: Towards an integrated approach*. UNEP/Earthprint.
- Abusa, F. (2011). *TQM implementation and its impact on organisational performance in developing countries: A case study on Libya*.
- Agnaia, A. A. (1997). Management training and development within its environment: The case of Libyan industrial companies. *Journal of European Industrial Training*, 21(3), 117–123.
- Al-Drugi, A., & Abdo, H. (2012). Investigating the development of environmental disclosures by oil and gas companies operating in Libya: A comparative study. *International Journal of Economics and Finance Studies*, 4(2), 1–10.
- Ali, I., & Harvie, C. (2013). Oil and economic development: Libya in the post-Gaddafi era. *Economic Modelling*, 32, 273–285.
- Bayagbon, A. M. (2011). *Impact assessment of the environmental protection policies in the upstream oil industry in Nigeria*. Master dissertation, North-West University, Potchefstroom Campus.
- Bindra, S. P., Hamid, A., Salem, H., Hamuda, K., & Abulifa, S. (2014). Sustainable integrated water resources management for energy production and food security in Libya. *Procedia Technology*, 12, 747–752.
- BPa. (2014, June). *BP statistical review of world energy* [online]. British Petroleum. Retrieved June 18, 2014, from <http://www.bp.com/content/dam/bp/pdf/Energy-economics/statistical-review-2014/BP-statistical-review-of-world-energy-2014-full-report.pdf>.
- BPb. (2002). *Environmental and social impact assessment methodology*. BTC Project ESIA, Georgia [Online]. Retrieved April 28, 2014, from [http://www.bp.com/liveassets/bp\\_internet/bp\\_caspian/bp\\_caspian\\_en/STAGING/local\\_assets/downloads\\_pdfs/xyz/BTC\\_English\\_ESIAs\\_Georgia\\_Content\\_BTC\\_ESIA\\_Sectio-dology\\_En\\_.pdf](http://www.bp.com/liveassets/bp_internet/bp_caspian/bp_caspian_en/STAGING/local_assets/downloads_pdfs/xyz/BTC_English_ESIAs_Georgia_Content_BTC_ESIA_Sectio-dology_En_.pdf).
- Bruhn-Tysk, S., & Eklund, M. (2002). Environmental impact assessment—A tool for sustainable development? A case study of bio fuelled energy plants in Sweden. *Environmental Impact Assessment Review*, 22(2), 129–144.
- Bukhari, A. (2013, February 5–6). Sustainable energy and environment: Objectives, challenges, the needs and the roadmap' (Conference presentation). In *Sustainable environment, climate change and renewable energy for oil and gas industry Doha, Qatar*. 21st Joint GCC\_Japan Environment Symposium.
- Campos, L. M. S. (2012). Environmental management systems (EMS) for small companies: A study in Southern Brazil. *Journal of Cleaner Production*, 32, 141–148.
- Darling, T. (2005). *Well logging and formation evaluation*. Amsterdam: Elsevier Science.



- Eidinov. (2004). Regulatory basis of environmental impact assessment: Methodological aspects of environmental and socio-economic impact assessment [Online]. Retrieved January 7, 2013, from <http://www.unece.org/fileadmin/DAM/env/eia/documents/CentralAsiaGuidelines/Annex%204%20-%20English.pdf>. AGIP KCO, Kazakh Agency of Applied Ecology.
- Energy Information Administration (EIA). (2014). *Monthly energy review* [online]. U.S. Department of Energy. Retrieved September 23, 2014, from <http://www.eia.gov/totalenergy/data/monthly/pdf/mer.pdf>.
- European Commission. (2010). *Registration of crude oil imports and deliveries in the European Union (EU27) (1) (INTRA + EXTRA EU)* [online]. European market observatory for energy. Retrieved June 15, 2014, from [http://ec.europa.eu/energy/observatory/oil/import\\_export\\_en.htm](http://ec.europa.eu/energy/observatory/oil/import_export_en.htm).
- Garg, A., Vishwanathan, S., & Avashia, V. (2013). Life cycle greenhouse gas emission assessment of major petroleum oil products for transport and household sectors in India. *Energy Policy*, 58, 38–48.
- Gilbuena, R., Jr., Kawamura, A., Medina, R., Nakagawa, N., & Amaguchi, H. (2013). Environmental impact assessment using a utility-based recursive evidential reasoning approach for structural flood mitigation measures in Metro Manila, Philippines. *Journal of Environmental Management*, 131, 92–102.
- Goodland, R., 1995. The concept of environmental sustainability. *Annual Review of Ecology and Systematics*, 26(1), 1–24.
- Goodland, R. J. A. (2013). *Libya: The transition to environmental sustainability*. Library of Congress Cataloguing-in-Publication Data. ISBN: 978-0-9792179-0-6.
- Goodland, R., & Daly, H. (1996). Environmental sustainability: Universal and non-negotiable. *Ecological Applications*, 6(4), 1002–1017.
- Green Oil & Akakus. (2008). Environmental baseline survey. *Azzawya Oil Refinery Co.* Final Report: V0.2.
- Hu, G., Li, J., & Zeng, G. (2013). Recent development in the treatment of oily sludge from petroleum industry: A review. *Journal of Hazardous Materials*, 261, 470–490.
- Ikein, A. (1990). *The impact of oil on a developing country*. New York: Praeger.
- Irhoma, A., Su, D. Z., & Higginson, M. (2013). Analysis of the barriers to environmental management systems implementation in the Libyan oil industry. *Key Engineering Materials*, 572, 672–677.
- Kharaka, Y. K., & Otton, J. K. (2003). Environmental impacts of petroleum production: initial results from the Osage-skiatook petroleum environmental research sites, Osage county, Oklahoma. US Department of the Interior, US Geological Survey.
- Melitah Oil & Gas B. V. (2014). *Al Wafa oil field* [online]. Retrieved June 4, 2014, from <http://www.mellitahog.ly/sites/details.php?id=10>.
- Modak, P., & Biswas, A. K. (Eds.). (1999). *Conducting environmental impact assessment in developing countries*. United Nations University Press.
- Mohamed, A. M. A., Al-Habaibeh, A., & Abdo, H. (2013). An investigation into the current utilisation and prospective of renewable energy resources and technologies in Libya. *Renewable Energy*, 50, 732–740.
- NOC. (2014). *Libyan national oil corporation* [online]. Retrieved June 1, 2014, from <http://noc.ly/index.php/en/>.
- Nooman, D. C., & Curtis, J. T. (2003). Exploration and production waste management. *Journal of Petroleum Technology*, 85(2).
- OPEC. (2014). *Libya facts and figures* [online]. Organisation of the petroleum exporting countries. Retrieved June 7, 2014, from [http://www.opec.org/opec\\_web/en/about\\_us/166.htm](http://www.opec.org/opec_web/en/about_us/166.htm).
- Saleh, I. M. (2006). Prospects of renewable energy in Libya. In *Solar physics and solar eclipses (SPSE 2006)* (Vol. 1).
- Schweitzer, D. (2010). *Oil companies and sustainability: More than just an image?* Retrieved from <http://deepblue.lib.umich.edu/bitstream/handle/2027.42/77607/dschwei.pdf>.
- Toro, J., Requena, I., Duarte, O., & Zamorano, M. (2013). A qualitative method proposal to improve environmental impact assessment. *Environmental Impact Assessment Review*, 43, 9–20.

- UNEP. (1997). Oil industry international exploration, & production forum. In *Environmental management in oil and gas exploration and production: An overview of issues and management approaches* (Vol. 2). UNEP/Earthprint.
- Vandewalle, D. J. (1998). *Libya since independence: Oil and state-building*. IB Tauris.
- Wathern, P. 1994. Environmental impact assessment: theory and practice, Biddles Ltd, Guilford and King's Lynn, London, pp. 3–46.
- Wood, C. (2003). *Environmental impact assessment: A comparative review*. Pearson Education.
- World Commission on Environment and Development (WCED). (1987). *Our common future*. Oxford University Press.
- Zaky, O. (2013). *Reputation drivers for oil and gas sector. How do oil and gas companies leverage on their sustainability reports to enhance their corporate reputation?* A qualitative content analysis for companies operating in oil and gas. Masters, Politecnico di Milano University.

# Chapter 12

## Environmental Impact Assessment of Farming with Combined Methods of Life Cycle Assessment and Farm Carbon Calculator



Daizhong Su, Jonathan Smith, You Wu, and Zhongming Ren

**Abstract** Nowadays, farming is one of the major sources of environmental impacts in the world. This research developed an approach of combining the *life cycle assessment* (LCA) and *Farm Carbon Calculator* (FCC) to assess the environmental impact of farming. The LCA is a general method covering a broad spectrum of environmental impact assessment and the FCC is a farming specific method focusing on carbon emission and sequestration. The approach is applied in an organic vegetable farm as an application scenario. In this chapter, the scope of the investigation is presented first, followed by assessing the environmental impact of farming by utilizing the LCA and FCC methods respectively. The assessments were conducted regarding key aspects of farming, including fuel/energy consumption, fertility improvement, materials, distribution, and waste/disposals. According to the assessment results, suggestions for reducing the environmental impact of farming are proposed. The outcome of the investigation proved the correctness and the compensative advantages of the approach.

**Keywords** Life cycle impact assessment (LCIA) · Carbon · Greenhouse gas emissions · Organic farming · Environmental impact calculation · Vegetable farm

---

D. Su (✉) · Y. Wu

Advanced Design and Manufacturing Engineering Centre, Nottingham Trent University,  
Nottingham, UK

e-mail: [daizhong.su@ntu.ac.uk](mailto:daizhong.su@ntu.ac.uk)

Y. Wu

e-mail: [you.wu@ntu.ac.uk](mailto:you.wu@ntu.ac.uk)

J. Smith

Jonathan Smith Consulting, Glasgow, UK

e-mail: [j.smith@scillyorganics.com](mailto:j.smith@scillyorganics.com)

Z. Ren

School of Art and Design, Shanghai University of Engineering Science, No. 333 Longteng Road,  
Songjiang 201620 Shanghai, China

e-mail: [zren@sues.edu.cn](mailto:zren@sues.edu.cn)

Shanghai Institute of Design and Innovation, Tongji University, No. 281 Fuxin Road, Yangpu  
200092 Shanghai, China

## Abbreviations

FCC	Farm Carbon Calculator
GHGs	Greenhouse Gases
LCA	Life Cycle Assessment
LCIA	Life Cycle Impact Assessment
LCI	Life Cycle Inventory
SO	Scilly Organics
SOM	Soil Organic Matter

## 12.1 Introduction

Agriculture occupies about 38% of Earth's terrestrial surface—the largest use of land on the planet (FAO 2012). The current food system is one of the most important contributors to the unsustainable nature of our society. Food production is a big resource consumer, responsible of 30% of global energy consumption (Foley et al. 2011) and 70% of the potable water use (EPHAC 2011). Most of energy consumption takes place downstream the farms in the supply chain. The total global contribution of agriculture, considering all direct and indirect emissions, represents between 17 and 32% of all global human-induced greenhouse gas (GHG) emissions, including land use changes (Smith et al. 2008).

The environmental impacts generated from farming have received great attention. Several methods and tools have been developed to address this issue, each of them with particular features for specific applications (van der Werf and Petit 2002; Payraudeau and van der Werf 2005; Galan et al. 2007). Mouron et al. (2012) propose a methodology to transform qualitative and quantitative assessments into sustainability attributes mainly intended for the implementation of Integrated Pest Management. Reganold et al. (2001) comprehensively evaluated the effects of three different farming methods on different sustainability indicators, as soil quality, horticultural performance, orchard profitability, environmental quality and energy efficiency. Lillywhite et al. (2007) assessed the socio-economic footprints of selected horticultural and agricultural sectors using nineteen different indicators.

Those methods bring valuable knowledge based on extensive studies. Nevertheless, easy to use and affordable methods are sometimes preferred, especially in preliminary studies or routine analyses to highlight the most critical aspects or impact variations in farming. In this research, an efficient strategy to provide fundamental data about the major sources of impacts in a specific farming scenario has been investigated with fast yet reliable results. This is achieved by utilizing two complimentary methods: a lifecycle assessment method and Farm Carbon Calculator, which are further presented in the following sections.

## 12.2 Assessment Methods and Application Scenario

### 12.2.1 *Life Cycle Assessment (LCA) and Farm Carbon Calculator (FCC)*

The LCA is a standardized method for the “compilation and evaluation of the inputs and outputs and the potential environmental impacts of a product system throughout its life cycle” (EN ISO 14040 2006; EN ISO 14044 2006). LCA has been used to calculate impacts from farming activities (van Zeijts et al. 1999; Tidåker et al. 2007; Nemecek et al. 2011; Mohammadi et al. 2013) and in the production field in general. Although it is not the only method to fully evaluate the environmental impacts of food production and consumption, LCA is particularly appreciated for its holistic and system wide view (Fosters et al. 2006). Anyway, it is necessary to broaden and supplement the LCA with other tools or methods (Jeswani et al. 2010) also to provide a basis for decision making (Curran 2013).

One of the major limits envisaged in LCA from farming stakeholders is the still debated exclusion of carbon sequestration by plants, i.e. the absorption of carbon dioxide by plants and its long term storage in biomass as lignin, and in soil as organic matter. Current LCA methodologies are not equipped to give any value to temporary carbon storage, as the amount of sequestered carbon would be subtracted from the emissions occurring at the end of the storage period to give a net zero emission (Lavasueur et al. 2012). Although CO<sub>2</sub> uptake could be modeled in an LCA, e.g. Deimling et al. (2008), and dynamic LCA methodology has been proposed for this purpose (Lavasueur et al. 2012), the international reference life cycle data system handbook (European Commission 2010) indicates that temporary carbon storage and the equivalent delayed emissions and delayed reuse/recycling/recovery within the first 100 years from the time of the study shall not be considered quantitatively.

There is considerable evidence that the potential for carbon sequestration in farmed soils is substantial. “The technical potential of carbon sequestration in world soils may be 2 billion to 3 billion mt per year for the next 50 years. Thus, the potential of carbon sequestration in soils and vegetation together is equivalent to a draw-down of about 50 parts per million of atmospheric CO<sub>2</sub> by 2100” (Lal 2009). Therefore, the reliance on a specialized tool for accounting for carbon sequestration in farming activities has been pursued in this research.

Several methods have been purposely developed for assessment of environmental impact in farming (Soil Association 2011) and among them the Farm Carbon Calculator (FCC n.d.) appears as a valuable method, merging comprehensiveness and easiness of use.

The FCC method provides an essential way of measuring the amount of carbon generated by farming and growing businesses, and the carbon absorbed by the soil and biomass on the land. The FCC method is derived from various valuable resources such as Defra (2017), Hammond and Jones (2011) and Brentrup et al. (2016)

In contrast with the LCA method, the FCC method measures the carbon sequestered in the farm’s soil, using soil organic matter (SOM) measurements carried

out by the farmers on a defined parts of their farm, on an annual basis. These are carried out using a strict set of pre-defined guidelines for soil measurement, and a list of laboratories that will accurately calculate the SOM to two decimal places.

### **12.2.2 Application Scenario**

In this research, LCA and FCC are used to calculate the environmental impacts of a specific scenario and the results are presented in this chapter. This research aims to test and verify a hybrid methodology allowing for the identification of significant sources of impacts in farming activities with a limited investment of effort, in order to orientate stakeholders pursuing environment-friendly strategies.

The application scenario of this study is an organic farm, Scilly Organics (SO), on St Martin's, Isles of Scilly, UK. It is a small organic horticultural farm, which has for the past ten years been pursuing strategies to minimize its carbon footprint and maximize carbon sequestration in the soil. The selection of organic produce as an application scenario was driven by the interest for stakeholders and scientific community to address the actual benefits from organic farming methods respect to conventional ones (Foster et al. 2006; de Backer et al. 2009; Hokazono and Hayashi 2012).

## **12.3 Scope of the Environmental Impact Assessment**

The functional unit in LCA terms (EN ISO 14040 2006) considered in this research is the annual production of fruit and vegetable produce in SO farm. It takes into account the constitutive nature of biological processes and long production cycles, with multiple product outputs. SO estimates an average yearly production of 1.5 tonnes of potatoes and 5 tonnes of other vegetables, from a piece of land of approximately 2 ha. The other vegetables mainly include carrots, onions, broccoli, kale, chard, tomatoes, cucumbers, beetroot, squash, lettuce, leeks, courgettes, and low weight crops (e.g. herbs and strawberries).

The sources of the impacts considered for the environmental impact assessment in this scenario belong to the following five major categories:

- Agricultural materials, i.e. bought items and the transports for their delivery till the farm's gate, such as metals mainly intended for weed control or glasshouse fitting, building materials such as wood and cement, office consumables such as paper, etc.
- Fertility improvement, i.e. materials and activities to increase soil fertility;
- Fuel, i.e. sources of power including gas, solid and liquid fuels and electricity from national grid;
- Distribution, i.e. delivering the produce to clients;
- Waste, i.e. the management of discarded materials.

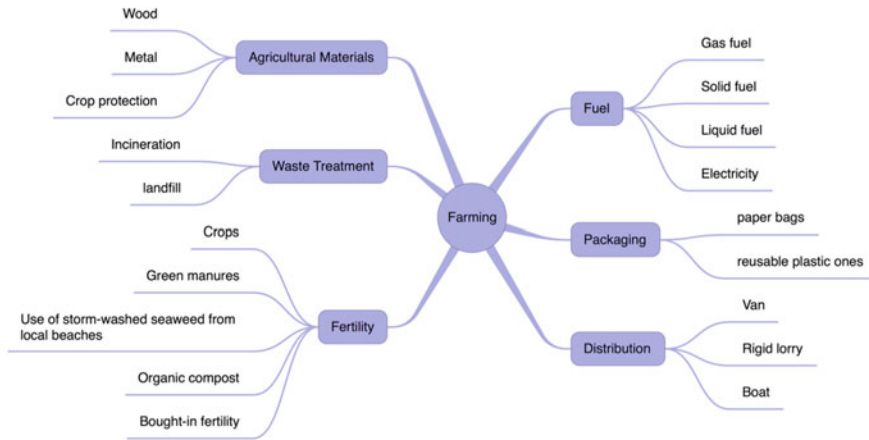

**Fig. 12.1** Scope of the environmental analyses

Notably, passively collected rainwater satisfies irrigation water demand, and capital items (namely a tractor) are accounted for according to depreciation rules that any item under 10 years old is depreciated at 10% per year until year 10. After that, it is considered to have paid off its ‘carbon debt’.

Fertility improvement is mainly based on a crop rotation system (four year cycle), green manure (pure stands of white and sweet clovers mainly, approx 0.5 ha per year), and use of storm-washed seaweed from local beaches and organic compost produced in the farm.

The produce is distributed to customers mainly on a local level by boat and van. For this purpose compostable paper bags and reusable plastic ones are used and accounted for. In the analysed scenario, an exceptional order for a large quantity of potatoes has been placed. Therefore, the delivery by lorry has been included likewise.

The above mentioned scope of this research is shown in Fig. 12.1.

As in a conventional Cradle-to-Gate scenario, impacts from use phase have been excluded from this study although they could be significant yet inferior to the production phase (Stichnothe et al. 2008; Virtanen et al. 2011), because of the complexity of defining an average scenario for food transformation and consumption and in order to keep the focus on strictly farming related activities.

In addition, the following are also not considered within the scope of the environmental impact assessment of this research: variations into the soil N<sub>2</sub>O levels namely generated by denitrification, travel by people to work, changes in land use. Impacts from growing of seed potatoes and onions sets, organic seeds (negligible), provision of services such as banking and insurance, and delivery of various other products, other than potatoes, have all been excluded due to lack of data.

## 12.4 Life Cycle Inventory (LCI) Data

It is fundamental to obtain the LCI data in order to carry out the life cycle assessment. In this research, the LCI data are supplied by the SO farmer and owner, who provided good quality data especially regarding fertility improvement, energy and fuel, consumables, overheads, transport and distribution. Average quality data have been provided for packaging composition and for waste management. The inventory database Ecoinvent (Frischknecht et al. 2007) is also consulted for any missing data necessary for the environment assessment.

Table 12.1 shows the input data utilized in this research. Due to lack of the source of accurate data, some assumptions have been made based on the practice of SO as shown in Table 12.2. The data shown in the two tables have been applied in both the LCA and FCC assessments described in Sects. 12.5 and 12.6.

## 12.5 Assessment with the LCA Method

### 12.5.1 *The LCA Methodology*

In this study a streamlined LCA has been conducted. According to EN ISO 14040 (2006), the LCA is composed of four main stages: goal and scope definition, life cycle inventory (LCI), life cycle impact assessment, and interpretation of the results.

In this research, the Goal and Scope Definition is aimed at identifying the objective, functional unit, system boundaries, LCI data sources and data quality requirements. The objective is to calculate the environmental impacts generated from the farming with the SO farm as an application scenario utilizing Cradle-to-Grave approach, i.e. from the supply source for the farming till waste management. The LCI consists of a detailed compilation of all the environmental inputs (material and energy) and outputs (air, water and solid emissions) at each stage of the life cycle.

Life Cycle Impact Assessment (LCIA) aims at quantifying the relative importance of all the environmental burdens identified in the LCI by analysing their influence on selected environmental effects. In this research the LCIA method ReCiPe (Goedkoop et al. 2009) is employed. The choice of ReCiPe LCIA method is mainly based on the possibility to show the results at the midpoint and end-point levels, a powerful strategy that bloomed after merging the two level results. Midpoint modelling is comprehensive with a relatively good level of certainty. End-point modelling, on the other hand, presents a more structured and informed trade-off across categories in terms of common, understandable indicators, making it useful to wide audiences (Singh et al. 2012). Impact items at the two levels are connected, as shown in Fig. 12.2. Furthermore the hierarchical approach of ReCiPe method has been chosen for this study as the most common policy principles with regard to time frame and other issues (Singh et al. 2012).



**Table 12.1** Input data

Source of impacts	Materials/Assemblies	Value	Unit
<i>Fuel</i>			
Butane	Propane/butane, at refinery/RER S	0.005	kg
Red diesel	Diesel, at regional storage/RER S	306	kg
Petrol	Petrol, unleaded, at regional storage/RER S	45.51	kg
Lubricants	Lubricating oil, at plant/RER S	1.32	kg
Wood logs	Heat, mixed logs, at wood heater 6 kW/CH S	15530	MJ
Non-renewable tariff	Electricity, medium voltage, production GB, at grid/GB S	1000	kWh
<i>Materials</i>			
Steel general	Steel, converter, unalloyed, at plant/RER S	20	kg
Timber general	Sawn timber, hardwood, planed, air/kiln dried, u = 10%, at plant/RER S	0.078	m <sup>3</sup>
Plywood	Plywood, indoor use, at plant/RER S	0.069	m <sup>3</sup>
Paint	Alkyd paint, white, 60% in solvent, at plant/RER S	4.74	kg
Bags polythene	Polyethylene, LDPE, granulate, at plant/RER S	33	kg
Bags paper	Kraft paper, unbleached, at plant/RER S	7	kg
Pallet stretch wrap LDPE film	Packaging film, LDPE, at plant/RER S	5	kg
Plastic general	Polyethylene, HDPE, granulate, at plant/RER S	15	kg
Materials paper	Paper, woodfree, uncoated, at regional storage/RER S	10	kg
Tyres rubber	Synthetic rubber, at plant/RER S	30	kg
Enviromesh	Polyethylene, HDPE, granulate, at plant/RER S	5.5	kg
<i>Fertility</i>			
Vermiculite and Coir	Expanded vermiculite, at plant/CH S	112	kg
Compost	Compost, at plant/CH S	4	ton
Green manures	Green manure organic, until January/CH S	0.435	ha
<i>Distribution</i>			
Van (up to 3.5t)	Transport, van < 3.5t/RER S	255.39	tkm
Articulated lorry (17–44t)	Transport, lorry 16–32t, EURO3/RER S	579.6	tkm
Articulated lorry (17–44t)	Transport, lorry 16–32t, EURO3/RER S	161	tkm

(continued)

**Table 12.1** (continued)

Source of impacts	Materials/Assemblies	Value	Unit
<i>Waste</i>			
Scrap metal and Tyres	Waste scenario/Eng S	40	%
Cardboard and Plastics	Packaging waste scenario/Eng S	60	%

**Table 12.2** Main assumptions made in relation to the impacts

Supplied material	Transport for supplied materials are referred to the travelled distance from the agents' site, since the country of origin is generally unknown
Coir production	Produced from husking coconuts, 35% of a nut weight is made of husk (website as in SimaPro). An average husk contains 70% coir dust
	The CO <sub>2</sub> emissions associated with the processing of coir are minimal and difficult to quantify
	Transport of coir is based on bulk transport by sea into Felixstowe (11,000 km) and some road transport at either end (150 km)
	Source: Defra (2009)
Plastic bags	Produced by blowing PE granulate as in Ecoinvent database
Energy	Based on Ecoinvent GB country mix and amended according to actual mix as provided by the supplier
Transports	Impacts from transports are based on Ecoinvent processes, as lorry van and boat

### 12.5.2 LCA Assessment Results

With the input data shown in Table 12.1, the environmental impact assessment of the farming is implemented using the LCA software package SimaPro with embedded LCI database Ecoinvent, and ReCiPe method Endpoint (H) V1.12/Europe ReCiPe H/A (PRé 2015). The assessment results are shown in Figs. 12.3, 12.4, 12.5, 12.6 and 12.7.

As can be noticed from Fig. 12.3, the impacts in this scenario derive from processes related to:

- farm fuel consumption (27.2%);
- improved land fertility (26.5%);
- farm waste disposal (20.4%);
- distribution out of farm gate (15%);
- materials used in the farm, or main overheads (10.9%).

Specific processes significantly influence the impacts deriving at each stage are shown in Fig. 12.4. In particular:

- disposal by municipality waste results to be the major source of impacts if single processes are considered (17%);

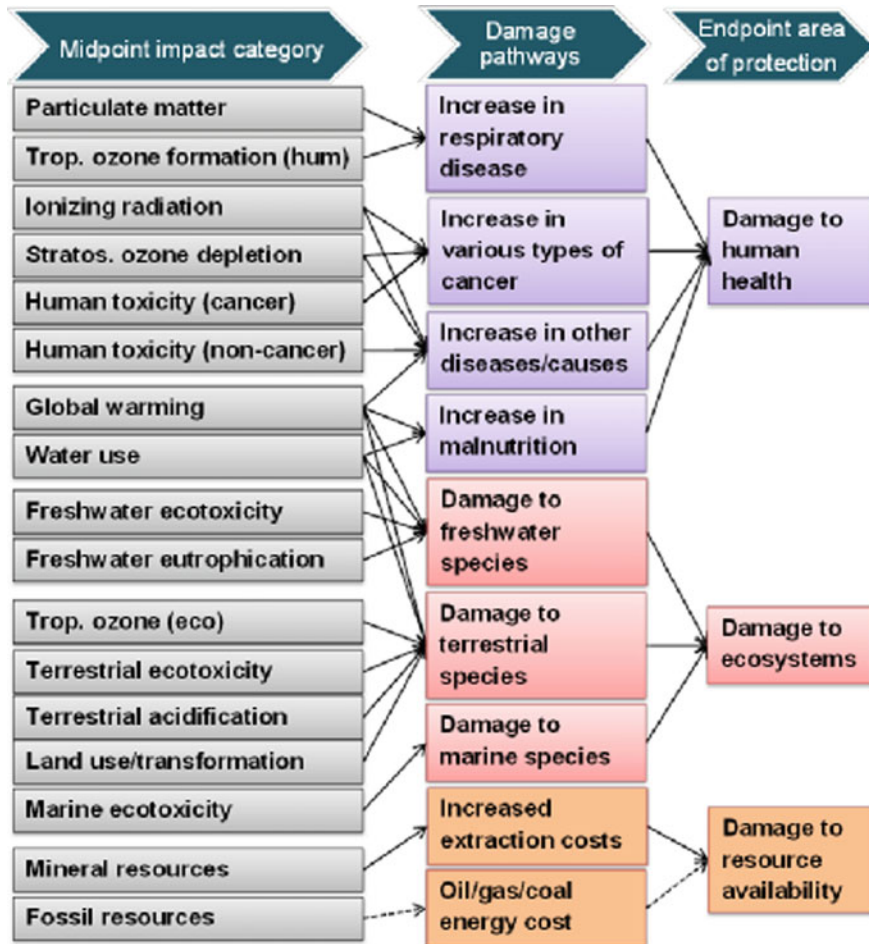

Fig. 12.2 ReCiPe method (Huijbregts et al. 2016)

- operations for ‘green manure organic’ represents the majority for impacts by fertility improvement, as it could be expected in this scenario (15%);
- compost produced on the farm remarkably contributes to the impacts (11%);
- energy mix from heat, electricity, diesel, and petrol (27% in total) represents more than a quarter of the total impacts.

Figures 12.5 and 12.6 show impact values in points (Pt) of **Wastes** and **Farming activities** on the end-points and mid-points results respectively. In the figures, the **waste** impacts are shown as ‘disposal of Scilly Organics Farm’ in red color and the impacts of **farming activities** are shown as ‘Scilly Organics Farm’ in blue color. The farming activities include Distribution, Fertility, Fuel and Materials.

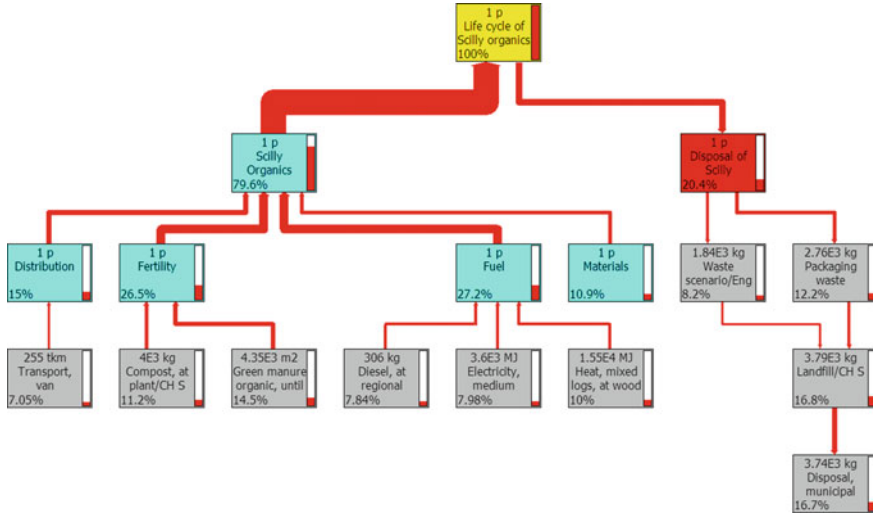

Fig. 12.3 Tree diagram of impacts related to processes (7% cut-off)

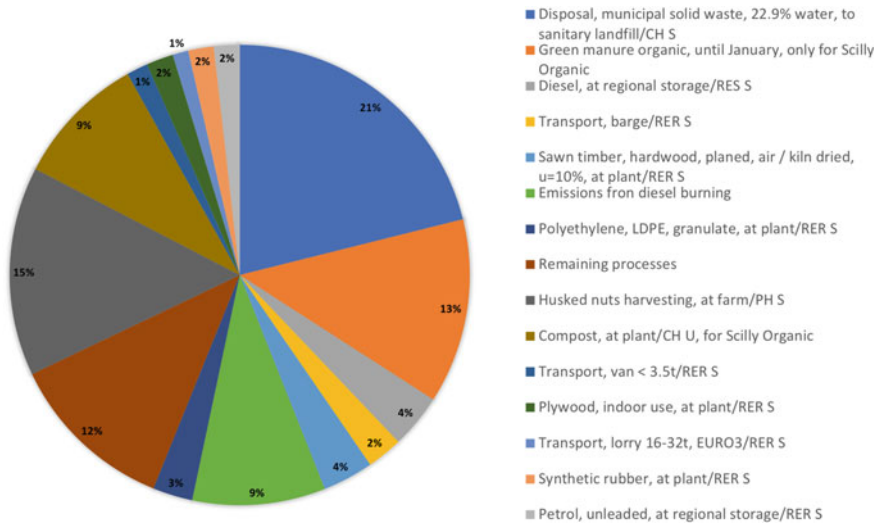
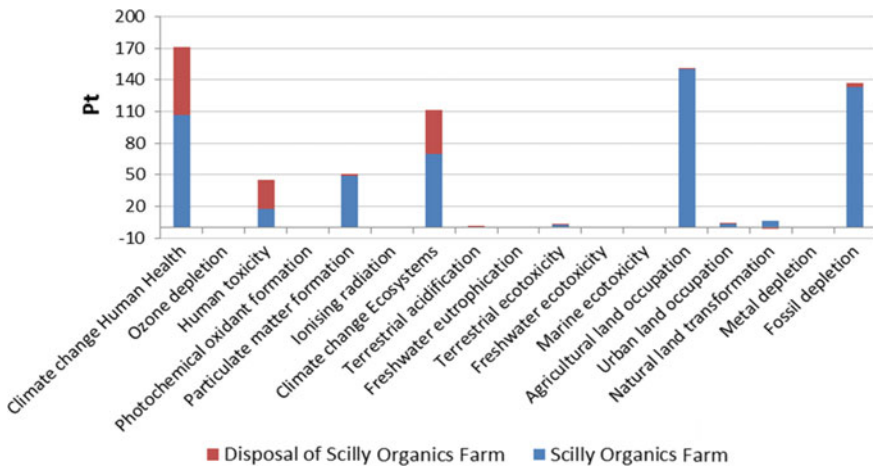
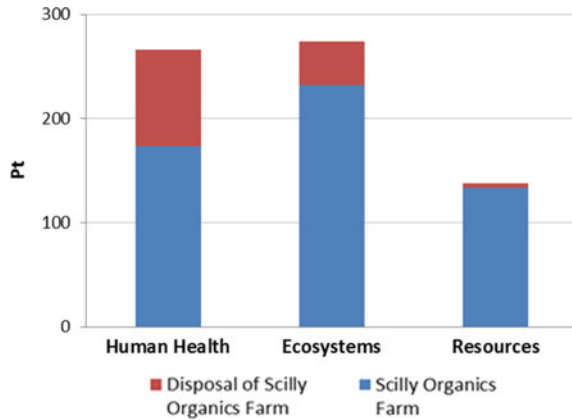

Fig. 12.4 Impacts from specific processes

**Fig. 12.5** Impact of end-point indicators



**Fig. 12.6** Impact of mid-pint indicators

The impact values of end-point indicators, as shown in Fig. 12.5, indicate the following:

- This farming scenario has highest impact on ecosystems, and the value of human health is very close to that of ecosystems. The impact of resources has the lowest value, which is just about half of ecosystems’ value.
- The farming activities (distribution, fertility, fuel and materials) has the highest impact on Ecosystems, middle impact on Human health and lowest impact on Resources.
- The waste (disposal) has highest impact on Human health and its value is about twice of its impact value of Ecosystems. It has little impact of Recourses.

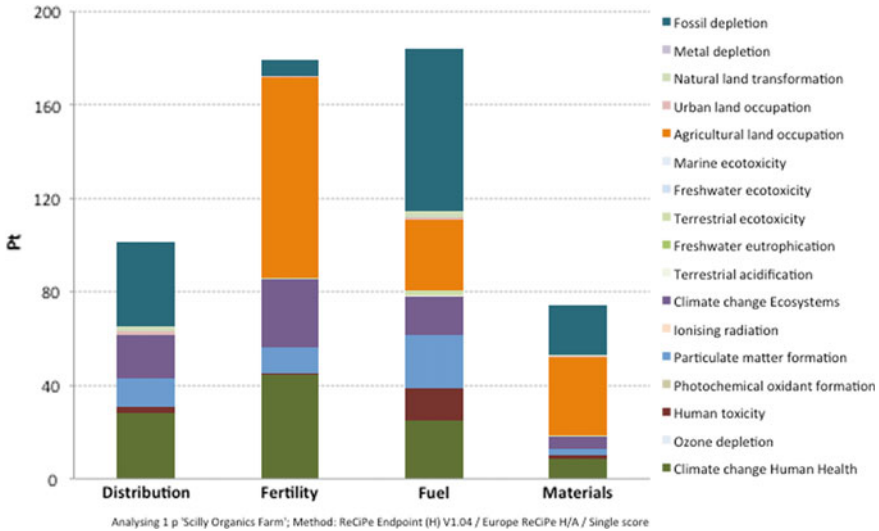

**Fig. 12.7** Impact of farming activities (distribution, fertility, fuel and materials) on the mid-point indicators

The impact values of mid-points, as shown in Fig. 12.6, reveal the following:

- Amongst the 17 mid-point indicators, this farming scenario mainly produces impacts on six indicators: *Climate change human health, Human toxicity, Particulate matter formation, Climate change ecosystem, Agricultural land occupation and Fossil depletion.*
- The waste (disposal) produces impacts mainly on three of the six mid-point indicators mentioned above, namely *Climate change human health, Human toxicity and Particulate matter formation.*
- Farming activities produce impacts on all the six indicators, with high impacts on *Agricultural land occupation, Fossil depletion and Climate change human health.*

The breakdown of the farming activities’ impacts on the mid-point indicators is shown in Fig. 12.7 which reveals the following

- The impacts produced by Fuel and Fertility are almost twice as the impact produced by Distribution and about 2.5 times of the impact produced by Materials.
- Fertility produces almost the half of the total impacts on Agricultural land occupation, which are mainly produced by Fertility, Fuel and Materials.
- Fertility produces the highest impact on Climate change human health.
- Fertility produces the highest impact on Climate change ecosystems.
- Fuel produces almost the half of the total impacts on Fossil depletion.
- Fuel produces the highest impact on Particulate matter formation.
- Fuel is the main producer of the impact on the Human toxicity.

## 12.6 Assessment with Farm Carbon Calculator (FCC)

### 12.6.1 *The FCC Methodology*

The FCC is a user-friendly online tool aimed at UK farmers and growers. It enables them to comprehensively and accurately assess their greenhouse gas emissions and carbon sequestration from their farm businesses. This includes production on farm, storage and transport to the point of sale.

The references used to build the Farm Carbon Calculator are freely available on the FCC website (FCC References n.d.). The approach of using a range of references is to ensure that the best available data are used for each specific section of the Calculator. Data from each peer-reviewed study are extracted by the FCC team, checked and peer reviewed.

In the FCC method, the difference between year x and year y, multiplied by the area of land, depth of measurement and soil bulk density gives a figure of carbon sequestered in tonnes of CO<sub>2</sub> per hectare per year.

Sequestration in biomass is attributable to all permanent and/or perennial crops on a farm (for example, apples, woodland, hedges, field margins) and is calculated according to the area (in hectares) of a given crop. Various factors can be included, such as specific species and age structure of woodland, or the length, width and management type of hedgerows. This ensures a good degree of accuracy, whilst being a flexible and user-friendly approach for farmers and growers.

The LCI data of the FCC cover all the categories related to farm and growing business. The LCI database of FCC is structured with nine **parameters**: Fuels, Materials consumed, Capital items, Fertility inputs, Agro-chemicals, Livestock emissions, Waste, Distribution and refrigeration, Carbon sequestration. Each parameter consists of a set of LCI data, for example, parameter **Fuels** include data of all types fuels and energy consumed, including gas fuels, solid fuels, electricity, liquid fuels, and the means of the fuel/energy consumption via transport (air, rail, bus, taxi, etc.) and contractors. For further details, please refer (FCC References n.d.) <https://farmcarbontoolkit.org.uk/sites/default/files/2018-Farm-Carbon-Calculator-reference-list.xls>.

It is not necessary to include all the nine parameters of LCI data in a FCC assessment application. The parameter selection depends on the nature of a particular application. In this research, the assessment is conducted with the SO scenario where there is no livestock, so the parameter **livestock emissions** are not considered; SO is an organic farm, so the **Agro-chemicals** is not applicable; and parameter of **Capital items** is not considered because this is no accurate data available.

## 12.6.2 FCC Assessment Results

With the input data presented in Sect. 12.4 and the methodology presented in Sect. 12.6.1, the environmental impact of SO is conducted using the Farm Carbon Calculator (FCC n.d.). The assessment results are obtained and presented with two indicators, **Carbon emissions** and **Carbon sequestration**, as shown in Tables 12.3 and 12.4 and related figures shown in this section.

According to Figs. 12.8 and 12.9, the following can be noticed.

- Amongst all the farming activities, Fuel is the major carbon emission producer of the SO scenario, the carbon emission of which is 3.82 times of fertility, and it made 70% of total carbon emission.
- Fertility is the second highest carbon emission producer, which produces 17% of total carbon emissions
- Amongst the remaining carbon emissions, 7% is from materials, 5% is from distribution and 1% from wastes.

**Table 12.3** Emissions of Scilly Organics carbon footprint using Farm Carbon Calculator

	CO <sub>2</sub> (kg/year)	% total emissions
Fuel	3,758	69.58%
Materials	386	7.14%
Capital items	0	0.00%
Livestock	0	0.00%
Fertility	942	17.44%
Agro-chemicals	0	0.00%
Distribution	258	4.77%
Waste	58	1.07%
<b>Total</b>	<b>5,401</b>	<b>100.00%</b>

**Table 12.4** Sequestration of Scilly Organics carbon footprint using Farm Carbon Calculator

	CO <sub>2</sub> (kg/year)	% total sequestration
Field margins	111	0.14%
Soil organic matter	57,064	71.97%
Orchards and Vineyard	207	0.26%
Wetland	0	0.00%
Woodland and Hedges	16,890	21.30%
Woodland (detailed analysis)	5,020	6.33%
<b>Total</b>	<b>79,292</b>	<b>100.00%</b>



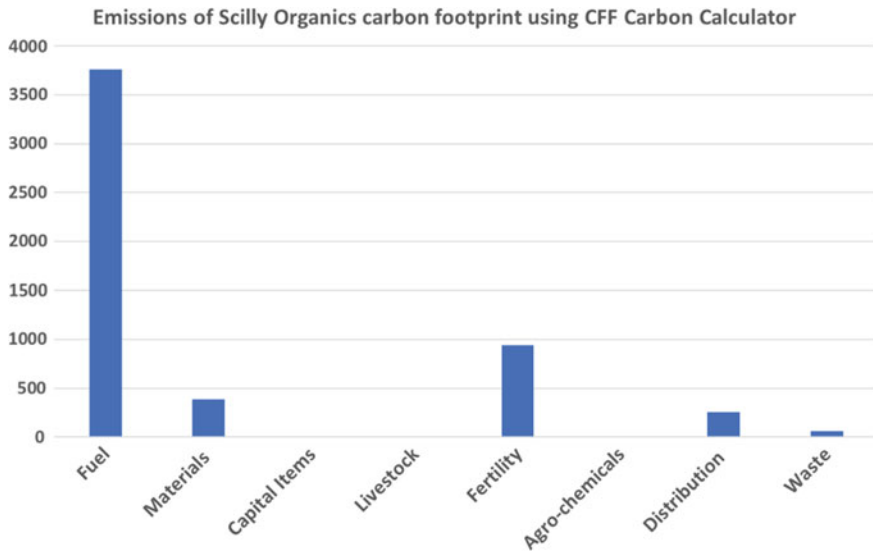
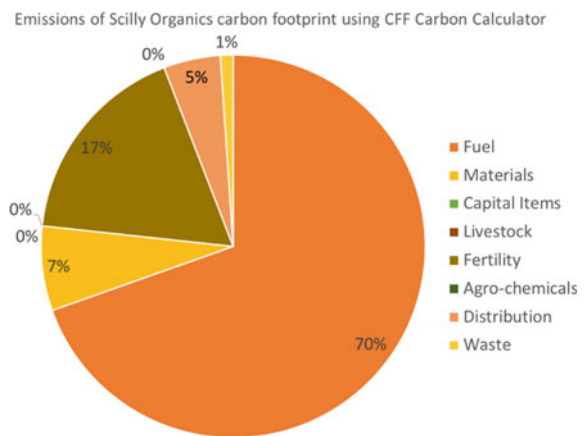

Fig. 12.8 Carbon emissions measured in kg/year

Fig. 12.9 Carbon emissions in percentages



According to Figs. 12.10 and 12.11, the following can be noticed

- Soil Organic Matters significantly absorb carbons of 57,064 kg per year, which is 72% of the total carbon sequestration of the farm. Such a high contribution is because the rate of increase in organic matter in this year was particularly high across the farm. This is due to the implementation of a policy of building soil organic matter.

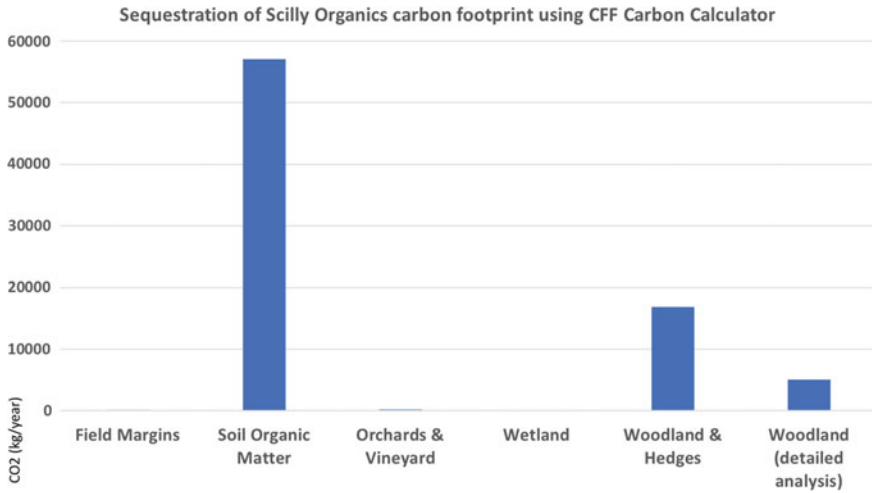

Fig. 12.10 Carbon sequestration measured in kg/year

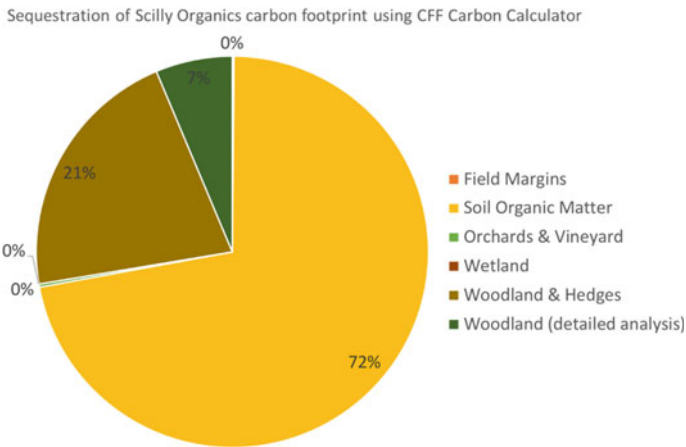

Fig. 12.11 Carbon sequestration in percentages

- Woodland and hedges rank the second, taking 21% of the total carbon sequestration of the form. This is due to a significant amount of the farm being covered in mature hedges, which are managed in a way to allow maximum carbon sequestration.
- Woodland (detailed analysis) contributes 7% of the total carbon sequestration, due to woodland areas, which make up a significant percentage of the farm area, and are quite young elm trees (approx 25 years old), at the peak rate of carbon sequestration in their growing lives.

- The contributions from Orchards and Vineyard and Field Margins are less than 1%, which can be ignored. This is because the area of orchard and vineyard is very small, and the plants are not very large; therefore the amount of carbon sequestered in the biomass is quite small.

## 12.7 Discussion

### 12.7.1 *Compensative Advantages of Combining LCA and FCC into the Assessment of the Environmental Impact of Farming*

The two methods employed in this research, LCA and FCC, have different scopes and their results compensate with each other.

The results obtained from the assessment using ReciPe, the LCA method utilised in this research, present the environmental impact of the farming with 17 mid-points, covering a wide range of indicators, and three end-points (human health, eco-systems and resources), which enable people to *understand the environmental impact of the farming with a broad spectrum*.

The assessment results obtained from the FCC, focus on two particular aspects of carbons, carbon emission and carbon sequestration, which enable people to understand the *environmental impact of the farming with the two particular indicators*. Significantly, the approach of FCC includes carbon sequestration in soils and perennial biomass, that have been ignored in the LCA approach.

### 12.7.2 *Comparative and Quantitative Measures*

In the LCA method, the impact is measured using points (Pt) and percentage (%), which indicate a particular indicator's importance level amongst all the indicators and, hence, enable the comparison of the impacts between the indicators. In other words, it provides a *comparative measure*.

In the FCC uses the carbon weight in kg per year (kg/yr) to indicate the impact, which gives a *quantitative measure*. For example, the impact of fertility is measured with LCA as 25.6% of the total impact amongst all the impact parameters (see Fig. 12.3), while it is measured with FCC as 942 kg/yr of carbon emissions (see Fig. 12.8).

It has to be pointed out that the results obtained from the two types of measures are not comparable with each other. However, they could support each other in the analyses of the impacts with the results obtained from the LCA and FCC, as further discussed below.

### 12.7.3 Discussion of the LCA and FCC Results

According to the LCA results presented in Sect. 12.5.2 and the FCC results presented in Sect. 12.6.2, the impacts jointly measured by the LCA and FCC are discussed below:

**Fuel** has the highest impact in both LCA and FCC assessments, which accounts for 27.2% of the overall LCA assessment and 70% of the total carbon emissions calculated by FCC. The impact on carbon emissions is extremely significant. To reduce the farm's environmental impact, it is essential to reduce the impact from fuels. The fuel investigated in this research is actually the power consumption, and the electricity and heat consumed takes considerable portion (18% of the total impact) which could be replaced by renewable energy. Considering the farm is located on an island in the sea, there are good resources of renewable energy, such as wind energy, solar energy and even ocean energy, so the use of renewable energy could be a good solution in reducing the impact of fuel.

**Fertility** ranks the second highest impact measured by both the LCA and FCC. It accounts for 26.5% of the overall LCA assessment, which is only 0.7% lower than that of Fuel, so it is almost the same important as Fuel in reducing the farm's environmental impact with consideration of LCA. However, it only counts 17% of the total carbon emissions of the farm, which is far less than the impact of Fuel. Therefore, reducing the impact of Fertility will have relatively low effect on the reduction of carbon emission, and considerable effects on reduction of the impacts on Climate change human health, Climate change ecosystem and Agricultural land occupation, because Fertility has the highest impact on the three mid-point indicators amongst other farming activities, as shown in Fig. 12.7. In particular, it could reduce half of the impact on the Agricultural land occupation. The impact of fertility is mainly due to green manure and compost production, as shown in Fig. 12.3. Green manure as a major source of impact has been highlighted by other studies likewise (e.g. Knudsen et al. 2013). However the holistic nature of analysis must be recognised here. In order to build soil organic matter the farmer needs to apply compost and/or grow green manures. Whilst there are some emissions and other negative environmental impacts associated with the process, the overall environmental impact is positive, as shown in the increase in soil organic matter and the resulting carbon sequestered.

**Materials** contributed 7% of the total carbon emissions and 10.9% of the total impact calculated by LCA. With the LCA assessment, as shown in Fig. 12.7, materials contribute about 25% of the impact on Agricultural land occupation, which cannot be ignored. Materials considered in this research are more about consumables such as office papers, plastic bags, etc. The impact could be reduced by reducing the consumables and using recycled materials.

**Distribution** has minor impacts on carbon emissions, 5% of the total carbon emission; but its impact calculated by LCA is higher, with 15% of the total impact. With the LCA assessment, as shown in Fig. 12.7, distribution contributes about 40% of impact on Fossil depletion and about 30% of impact on Climate change human health. Items considered in this activity include van and lorries used for

transportation, which could be reduced by SO selling more food local to the farm, therefore reducing distribution impacts. This is known as ‘food miles’.

**Waste**, i.e. disposal used in the LCA calculation, contributes about 1% of total carbon emissions, as calculated by FCC, which could be ignored; however, it contributes 20.4% of the total impact calculated by LCA, with impacts on *Climate change human health*, *Human toxicity* and *Particular matter formation*, as shown in Fig. 12.6. As indicated in Fig. 12.2, waste landfill contributes 16.8% of the total impact calculated by the LCA, while the whole waste contributes to 20.4% of the total impact. This means that 82% of the waste went to land fill, which is relatively high. Therefore, to reduce the impact from the waste, the landfill rate must be reduced. The waste items considered in this research include Scrap metal and tires and packaging waste of cardboard and plastics (see Table 12.1), a large amount of which could be recycled, therefore, the reduction of the landfill rate can be achieved, and, hence, the waste impact can be largely reduced. Certain elements of waste disposal impacts are dependent on the waste policies and systems of the Local Authority (Council of the Isles of Scilly) which is the only waste management organisation on the Islands. Greater opportunities for recycling in the waste system would enable reduced impacts from waste by the farm.

**Carbon sequestration**. As mentioned before, the LCA method ignores carbon sequestration, so it is discussed here based on the FCC results only. As shown in Tables 12.3 and 12.4, in this farming scenario, the total carbon sequestration is 79,292 kg/yr, while the total carbon emissions are 5,401 kg/yr. This means that the carbon absorbed and stored is nearly 15 times of the carbon emission per year in the farm. Soil Organic Matter is the main contributor to carbon sequestration, measuring 72% of the total. This is due to significant increases in soil organic matter levels across the two hectares of land that makes up SO. Due to the sandy nature of the soil on SO farm, the SOM levels are inherently low, but that does mean the capacity of the soil to increase SOM rapidly is increased. If SOM were to increase year on year, one may expect to see the rate of increase slow, but the increase could continue indefinitely at slower rates.

## 12.8 Concluding Remarks

This research implemented an approach of combining LCA and FCC to assess the environmental impact of farming. The LCA method utilises indicators of 17 mid-points and three end-points to assess the environmental impact, while the FCC method particularly focuses on the carbon emission and sequestration. The SO, an organic vegetable farm, was employed as an application scenario to illustrate the application of the combined methods. The results obtained successfully proved the advantages of this approach..

The LCA is a general method applicable to a wide range of application areas with a broad spectrum of environmental assessment, while the FCC is specific method for farming with focused indicators in carbon only. This research combined the two

methods into the environmental assessment, enabling both a wide coverage and an in-depth investigation. The outcome of this research proved the compensative advantages of the two methods. This is a valuable approach of environmental assessment, which is not only suitable for farming, but also applicable to other areas.

Based on the results of the assessment conducted in the SO application scenario with the combined approach, the following valuable findings are obtained:

- Fuel has the highest impact in both LCA and FCC assessments.
- Fertility ranks as the second high impact measured by both the LCA and FCC.
- Materials contributes 7% of the total carbon emission and 10.9% of the total impact calculated by LCA.
- Distribution has 5% of the total carbon emission and 15% of the total impact calculated by LCA.
- Waste contributes about 1% of total carbon emission, but contributes 20.4% of the total impact calculated by LCA.

Based on the above findings, the following are suggested to reduce the environmental impact of farming:

- Renewable energies such as wind energy, solar energy and even ocean energy should be used as much as possible to replace traditional fossil fuel energy.
- Fuel use in farm machinery, i.e. tractor, should be reduced as much as possible.
- The means to reduce the fertility's impact should be further investigated, but also assess how effective the fertility inputs are at building soil organic matter levels, the main driver of carbon sequestration.
- To reduce the impact from waste, the landfill rate must be reduced, while the recycle of the waste should be increased.
- The impact of materials could be reduced by reducing the quantity of consumables and using recycled materials.

The results obtained from this research are based on an organic farm. As a future work, the combined approach developed by this research could be applied in traditional farms, the results of which could then be compared with those of this research to see the differences.

**Acknowledgements** The authors acknowledge the financial supports received from the European Commission's FP7 Environment programme for myEcoCost project (Grant number 308530) and H2020 Circular Economy program for CIRC4Life project (Grant agreement number 776503). The authors thank Dr Giuseppe Salvia, former research fellow working at the Advanced Design and Manufacturing Engineering Centre of Nottingham Trent University, for his contribution to the research reported in this article.

## References

- Brentrup, F., Hoxha, A., & Christense, B. (2016). Carbon footprint analysis of mineral fertilizer production in Europe and other world regions, In *Proceedings of the 10th International Conference on Life Cycle Assessment of Food, October 2016*, University College Dublin, Dublin, Ireland.
- Curran, M. (2013). Life Cycle Assessment: A review of the methodology and its application to sustainability. *Current Opinion in Chemical Engineering*, 2, 1–5.
- de Backer, E., Aertsens, J., Vergucht, S., & Steurbaut, W. (2009). Assessing the ecological soundness of organic and conventional agriculture by means of life cycle assessment (LCA): A case study of leek production. *British Food Journal*, 111(10), 1028–1061.
- Deimling, S., Shonfield P., & Bos U. (2008). LCA and carbon footprints in agro-food: From theory to implementation in the food industry. In *Proceedings of the 6th International Conference on LCA in the Agri-Food Sector*. Zurich, 12–14 Nov 2008.
- Defra. (2017). 2017 GHG conversion factors. Retrieved August 9, from <https://www.greenstoneplus.com/blog/defra-2017-conversion-factors-whats-changed>.
- Defra. (2009). Research project final report 'A preliminary assessment of the greenhouse gases associated with growing media materials'. <http://scienceresearch.defra.gov.uk/Default.aspx?Menu=Menu&Module=More&Location=None&Completed=0&ProjectID=15967>.
- EN ISO 14040. (2006). Environmental management-Life cycle assessment-Principles and framework. International Organization for Standardization: Geneva, Switzerland.
- EN ISO 14044. (2006). Environmental management-Life cycle assessment-Requirements and guidelines. International Organization for Standardization: Geneva, Switzerland.
- European Commission, Joint Research Centre, Institute for Environment and Sustainability. (2010). *International reference life cycle data system (ILCD) handbook—General guide for life cycle assessment—Detailed guidance*. Luxembourg: Publications Office of the European Union.
- European Public Health and Agriculture Consortium (EPHAC) position on. (2011). *The future of the common agricultural policy*. Retrieved June 04, 2018, from <http://eurohealthnet.eu/sites/eurohealthnet.eu/files/publications/EPHAC-Position-Paper.pdf>.
- FAO. (2012). Road to Rio: Improving energy use key challenge for world's food systems. Retrieved July 24, 2018, from [www.fao.org/news/story/en/item/146971/icode](http://www.fao.org/news/story/en/item/146971/icode).
- FCC. (n.d). Farm Carbon Calculator. Retrieved August 10, 2018, from <http://farmcarbontoolkit.org.uk/carbon-calculator>.
- FCC References. (n.d). <https://farmcarbontoolkit.org.uk/sites/default/files/2018-Farm-Carbon-Calculator-reference-list.xls>.
- Foley, J. A., Ramankutty, N., Brauman, K. A., Cassidy, E. S., Gerber, J. S., Johnston, M., et al. (2011). Solutions for a cultivated planet. *Nature*, 478(7369), 337.
- Foster, C., Green, K., Bleda, M., Devick, P., Evans, B., Flynn A., et al. (2006). Environmental impacts of food production and consumption: A report to the department of environment, food and rural affairs.
- Frischknecht, R., Jungbluth, N., Althaus, H. J., Doka, G., Heck, T., Hellweg, S., et al. (2007). *Overview and methodology*. Ecoinvent report No. 1. Swiss Centre for Life Cycle Inventories, Dübendorf.
- Galan, M. B., Peschard, D., & Boizard, H. (2007). ISO 14001 at the farm level: Analysis of five methods for evaluating the environmental impact of agricultural practices. *Journal of Environmental Management*, 82(3), 341–352.
- Goedkoop, M., Heijungs, R., Huijbregts, M., De Schryver, A., Struijs, J., & van Zelm, R. (2009). ReCiPe 2008: A life cycle impact assessment method which comprises harmonised category indicators at the midpoint and the endpoint level. VROM—Ruimte en Milieu, Ministerie van Volkshuisvesting, Ruimtelijke Ordening en Milieubeheer. [www.lcia-recipe.net](http://www.lcia-recipe.net).
- Hammond, G., & Jones, C. (2011). *Inventory of energy and carbon v2.0*. University of Bath.
- Hokazono, S., & Hayashi, K. (2012). Variability in environmental impacts during conversion from conventional to organic farming: a comparison among three rice production systems in Japan. *Journal of Cleaner Production*, 28, 101–112.

- Huijbregts, M. A. J., Steinmann, Z. J. N., Elshout, P. M. F., Stam, G., Verones, F., Vieira, M. D. M., et al. (2016). *ReCiPe2016: A harmonized life cycle impact assessment method at midpoint and endpoint level*. RIVM Report 2016-0104. Bilthoven, The Netherlands. Retrieved September 3, 2018, from [https://www.rivm.nl/en/Topics/L/Life\\_Cycle\\_Assessment\\_LCA/Downloads](https://www.rivm.nl/en/Topics/L/Life_Cycle_Assessment_LCA/Downloads).
- Jeswani, H. K., Azapagic, A., Schepelmann, P., & Ritthoff, M. (2010). Options for broadening and deepening the LCA approaches. *Journal of Cleaner Production*, 18(2), 120–127.
- Knudsen, M. T., Meyer-Aurich, A., Olesen, J. E., Chirinda, N., & Hermansen, J. E. (2013). Carbon footprints of crops from organic and conventional arable crop rotations—using a life cycle assessment approach. *Journal of Cleaner Production* (in press).
- Lal, R. (2009). The potential for soil carbon sequestration. International Food and Policy Research Centre.
- Levasseur, A., Lesage, P., Margni, M., & Samson, R. (2012). Biogenic carbon and temporary storage addressed with dynamic life cycle assessment. *Journal of Industrial Ecology*, 17(1), 117–128.
- Lillywhite, R., Chandler, D., Grant, W., Lewis, K., Firth, C., Schmutz, U., et al. (2007). Environmental Footprint and Sustainability of Horticulture (including Potatoes)—A Comparison with other Agricultural Sectors. Final report produced for the Department for Environment, Food and Rural Affairs (Defra) UK.
- Mohammadi, A., Rafiee, S., Jafari, A., Dalgaard, T., Knudsen, M. T., Keyhani, A., et al. (2013). Potential greenhouse gas emission reductions in soybean farming: A combined use of Life Cycle Assessment and Data Envelopment Analysis. *Journal of Cleaner Production*, 54(1), 89–100.
- Mouron, P., et al. (2012). Sustainability assessment of crop protection systems: SustainOS methodology and its application for apple orchards. *Agricultural Systems*, 113, 1–15.
- Nemecek, T., Huguenin-Elie, O., Dubois, D., Gaillard, G., Schaller, B., & Chervet, A. (2011). Life cycle assessment of Swiss farming systems: II. Extensive and intensive production. *Agricultural Systems*, 104(3), 233–245.
- Payraudeau, S., & van der Werf, H. M. G. (2005). Environmental impact assessment for a farming region: a review of methods. *Agriculture, Ecosystems & Environment*, 107(1), 1–19.
- PRé. (2015). *SimaPro database manual* (pp. 1–78). Amersfoort, The Netherlands: PRé Consultants.
- Reganold, J. P., Glover, J. D., Andrews, P. K., & Hinman, H. R. (2001). Sustainability of three apple production systems. *Nature*, 410, 926–930.
- Singh, B., Strømman, A. H., & Hertwich, E. G. (2012). Environmental damage assessment of carbon capture and storage. *Journal of Industrial Ecology*, 16(3), 407–419.
- Smith, P., et al. (2008) *Cool Farming*. Report, Greenpeace.
- Soil Association. (2011). Carbon footprinting on farms. Information Sheet.
- Stichnothe, H., Hospido, A., & Azapagic, A. (2008). Carbon footprint estimation of food production systems: The importance of considering methane and nitrous oxide. *Aspects of Applied Biology*, 87, 65–75.
- Tidåker, P., Mattsson, B., & Jönsson, H. (2007). Environmental impact of wheat production using human urine and mineral fertilisers—A scenario study. *Journal of Cleaner Production*, 15(1), 52–62.
- Virtanen, Y., Kurppa, S., Saarinen, M., Katajajuuri, J. M., Usva, K., Mäenpää, I., et al. (2011). Carbon footprint of food—approaches from national input–output statistics and a LCA of a food portion. *Journal of Cleaner Production*, 19(16), 1849–1856.
- van der Werf, H. M. G., & Petit, J. (2002). Evaluation of the environmental impact of agriculture at the farm level: A comparison and analysis of 12 indicator-based methods. *Agriculture, Ecosystems & Environment*, 93(1–3), 131–145.
- van Zeijts, H., Leneman, H., & Sleeswijk, A. W. (1999). Fitting fertilisation in LCA: Allocation to crops in a cropping plan. *Journal of Cleaner Production*, 7(1), 69–74.



# Chapter 13

## Assessment of the Environmental Impact of Lighting Product



Jose L. Casamayor and Daizhong Su

**Abstract** This chapter explains how to assess the environmental impact of lighting products by applying Life Cycle Assessment (LCA) methodology, and how the LCA results can be used to inform eco-design recommendations to reduce the environmental impact of lighting products. This is illustrated using a real-life example, where the environmental impact of a lighting product manufactured by a lighting manufacturer is assessed with Simapro (LCA-based software). After the illustration, the limitations of LCA are discussed.

**Keywords** Lighting · Luminaire · Environmental impact · Life cycle assessment · Life Cycle Impact Assessment · Sustainable Product Design · Eco-design

### 13.1 Environmental Impact of Lighting Products

Lighting products cause an environmental impact at each stage of their product life cycle. The environmental impact is due to the consumption of materials and energy (input) and the production of waste and emissions (output) as shown in Fig. 13.1. In order to reduce the environmental impact of lighting products these inputs and outputs have to be reduced or eliminated.

The product life cycle comprises several stages: extraction and processing of materials, manufacturing of product and packaging, distribution (or transport), use, and End of Life (EoL). In each stage, environmental impact is produced due to the use of materials and energy (input) and the production of waste and emissions (output), as shown in Fig. 13.2.

---

J. L. Casamayor (✉)  
Coventry University, Coventry, UK  
e-mail: [ac8335@coventry.ac.uk](mailto:ac8335@coventry.ac.uk)

D. Su  
Advanced Design and Manufacturing Engineering Centre, Nottingham Trent University,  
Nottingham, UK  
e-mail: [daizhong.su@ntu.ac.uk](mailto:daizhong.su@ntu.ac.uk)



**Fig. 13.1** Causes of environmental impact

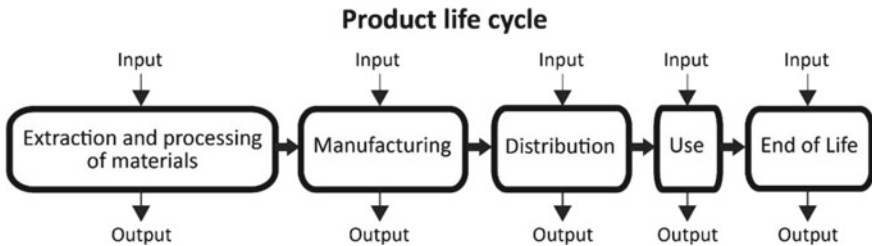

**Fig. 13.2** Product life cycle stages

In order to reduce the environmental impact of lighting products, the amount of non-renewable material, energy consumption, emissions and waste have to be reduced or eliminated.

## 13.2 How to Reduce the Environmental Impact of Lighting Products

The production of lighting products produces considerable impact on the environment. There are two approaches to reduce the environmental impact during the production of lighting products: (1) to reduce the environmental impact of lighting products after the products have already been designed, which is so called 'end of pipe' solutions, and (2) to reduce the environmental impact of lighting products at the design stage.

The reduction of environmental impact using the first approach is limited, because it is difficult to reduce drastically the negative effect on the environment of a lighting product that has already been defined (i.e. there is no possibility to change the structure and the materials used in the product). The only possible strategies to reduce the impact when the product has been already designed is to decrease the environmental impact of the remaining stages of the industrial process, such as manufacture and distribution (transport), or to optimise the manufacturing process to use less resources and produce less waste.

Using the second approach can produce higher environmental impact reductions, because at the design stage the complete architecture and life cycle of the lighting product can be decided (designed), and these design decisions will be reflected in

the environmental impact of the lighting product. Once the lighting product has been defined, implementing 'end-of-pipe' strategies to reduce the environmental impact are usually costly and reduction effects on the environment are minimal. About 80% of the products' total environmental impact is determined at the design stage (Charter and Tischner 2001; Mcalooone and Bey 2009), so more attention should be paid at the design stage of lighting products to reduce their environmental impact.

### 13.3 Environmental Impact Assessment Tools

To reduce the environmental impact of products during the design stage, it is necessary to apply and integrate environmental impact assessment tools within the design process. These tools adopt a holistic life cycle approach that assess the environmental impact created in all life cycle stages of the products, from extraction of materials to the End of Life (EoL) stage. Only then, the impact can be identified and, subsequently, the reduction and/or elimination of this can then be implemented. Numerous environmental impact assessment tools have been developed (Wrisberg et al. 2002; Finnveden and Moberg 2005) to assess and identify environmental impacts caused by products.

One of the environmental impact assessment tools that can be used to quantitatively assess the environmental impact of products is the LCA Methodology. Today, standardisation of LCA methodology has strengthened its status as perhaps the most valuable tool for assessing a product's overall environmental impact (Malmqvist 2004). LCA, adopts a life cycle approach, and involves the evaluation of all aspects of a product system through all the stages of its life cycle.

However, LCAs results are never complete and entirely accurate because, usually, it is not possible to have access to all the required data, (i.e. all the data from the processes and materials involved in the life cycle of a product), so all LCA results can be considered 'streamlined' or simplified to some extent. All LCAs omit data and make assumptions, but the degree of these uncertainties may change from assessment to assessment. Sometimes, the omission or simplification (streamlining) of the assessment is purposefully made by reducing the scope of the study, or by reducing data needs through the substitution of surrogates for data that may not be readily available to the practitioner (Hur et al. 2005). In these cases, assessments are simplified because the product developer may not need the full results of the assessment or may not need very accurate results. For example, when the aim of the assessment is to compare two different products that use different transport modes, the comparison will have to be focused on in the transport stage, and there is no need to include other stages such as the manufacturing, use or end of life stages in the assessment. In addition to this, during the initial stages of the design process, the product is not defined enough to know all the real (not assumed) required data, so many assumptions are made. Even though this type of assessments omit or assume a lot of data, the results are still useful to provide information about which are the life cycle stages

and components with higher impact, which can then guide designers about which areas should they focus their eco-design activities.

LCA can be used for different purposes during the design process. It can be used when the product is finished and manufactured to provide an environmental profile of the product for eco-redesign, where a reference product is needed, or marketing (eco-labels) purposes, or to support product developers' design decisions during the design process by identifying the life cycle stages or components with higher impact.

A LCA consists of the following stages: (1) Goal and scope definition, (2) Life Cycle Inventory (LCI), (3) Life Cycle Impact Assessment (LCIA), and (4) Life Cycle Interpretation (Lewis et al. 2001, Jensen et al. 1997).

The LCA methodology is usually embedded in software applications (i.e. LCA-based software tools). There are different types of LCA-based software tools that can be used for different purposes. The majority of these have been developed to assess generic products, but there are also tailored LCA-based software tools that have been customised for specific applications (e.g. products). These are also company-specific adaptations of LCA-based software tools to suit the needs of the company. These tools usually contain databases with internal data of the company, as well as secondary data to account for background data.

Some of the LCA-based software have been simplified to suit non-LCA experts needs, like product designers, and other LCA-based software tools present more complex and advanced interfaces and features allowing more complex assessment, which is usually required by LCA experts.

There are many LCA-based software tools available in the market. They differ in their user interface, databases embedded, LCIA methods utilised, results display options, usability, complexity of assessment, and advanced features offered. Some of them present similar specifications but are manufactured by different suppliers. The most relevant LCA-based software tools used to model the environmental impact of products are the following: Simapro (PRé Consultants 2018), Gabi (Thinkstep 2018) and Sustainable Minds (2018). Simapro and Gabi allow to carry out detailed modelling and assessment of the environmental impact of any product produced in nearly any part of the world (the databases have worldwide coverage), and also allow to conduct complex end of life scenarios. These software tools also have an extensive range of up-to-date databases and LCIA methods to conduct the assessment, and extra databases and LCIA methods can be imported. Sustainable Minds is less advanced than Simapro and Gabi and does not allow to conduct detailed assessments with complex end of life scenarios. However, it allows to import Bill of Materials (BoM) from CAD software, and the possibility to compare-assess different concept designs, or design decisions (e.g. different materials) easily.

In the example used in Sect. 13.4 of this chapter, to illustrate the application of LCA during the design process, the LCA-based software 'Simapro' is used to conduct the LCA of the lighting product.

## 13.4 Example of Application of LCA to Assess Lighting Products

This section illustrates with an example how to apply LCA to assess the environmental impact of a lighting product during the design stage, and how to use the LCA results to inform design decisions to reduce the environmental impact of the lighting product.

The example is based on the LCA of the lighting product whose details are given in Sect. 13.4.1. The LCA is carried out using SimaPro V.8.2.3 (PRé Consultants 2018) software in line with LCA standards (ISO 2006a, b) and Ecoinvent V.3.2 (Ecoinvent 2018) is used as the database. Six scenarios are assumed in the assessment, one of which is used as the base-case scenario. The base-case scenario assumes that the lighting product is used for 40,000 h and disposed of in domestic bins in the Netherlands. In the other five scenarios, different useful lives of the lighting product are assumed, and recycling in the end of life scenario is also considered.

In order to conduct the assessment, the life cycle inventory (LCI) of the product (i.e. all the materials and processes involved in the product life cycle) has to be input into the software. The LCI is then assessed using a particular LCIA method (e.g. ReCiPe). The software allows choosing different LCIA methods according to the LCA purpose. Each of these LCIA methods interprets and assesses the LCI based on specific criteria and environmental impact indicators. After assessing the LCI with a LCIA method, results are presented based on different environmental impact indicators.

### 13.4.1 *The Lighting Product Assessed*

The lighting product assessed (Fig. 13.3) is a modular table lamp LED-based lighting product, manufactured by Ona Product S.L. (2018). It can provide ambient, task and accent lighting, and presents the following eco-features and lighting performance features:

Eco-features:

- The casing is made of recycled PET.
- A novel ad hoc inter-module joint that allows several functions in one single part: this snap-fit joint allows full rotation of the modules whilst passing IP 44 (IEC 2013) and CE marking (EC 2018) safety tests; it also allows easy attachment–detachment (i.e. upgrade) of additional lighting modules.
- The joint that connects the modules allows light directional control, which means that light can be directed where is needed, thus saving light and energy. It also allows the lighting product to ‘evolve’ according to users’ needs over time (e.g. more lighting modules can be added if the lighting needs change over time, which avoids having to buy new lighting products), thus extending its lifespan. This joint

**Fig. 13.3** Lighting product

also allows simplification of the casing manufacture and reduces the number of parts that need to be manufactured to achieve the rotation function.

- The architecture of the product allows easy-fast access to components, and dis-assembly without the need for tools. This facilitates the repair and upgrade of components, thus extending the lifespan of the lighting product.

Lighting performance features:

- Full light control: Light output can be controlled with dimmers, and the light distribution can be adjusted by the individual orientation of each lighting module, which can be rotated 360° in horizontal and vertical directions. This allows usage of the exact amount of light needed where needed, thus saving light and energy.
- The luminous efficacy of the lighting product is 55 lm/W, which is a decent luminous efficacy level. The Energy Star (Energy Star 2018) label for lighting products recommends at least 50 lm/W for directional desk-lighting products. This is one of the main issues to take into account in the design of lighting products because the electricity consumed is usually the main contributor to the total environmental impact. Higher luminous efficacy means that the lighting product can produce higher light output with lower electricity consumption.
- It uses three LEDs, each of which is housed in an individual lighting module. It has a modular structure and can use up to four lighting modules; but in this study, the version with three modules is considered. The technical specifications of the lighting product are shown in Table 13.1 and Fig. 13.4.

**Table 13.1** Technical specifications of lighting product

	3 Lighting modules/LEDs—Version
Weight (g)	2133
Dimensions: x, y, z (cm)	45 × 72 × 19
Luminous flux of luminaire (lm)	948
Illuminance (lx) on luminaire’s base	3825
Luminaire efficacy (lm/W)	55
Power consumption of luminaire (W)	17.2
Light Output Ratio (LOR)	0.9
Correlated Color Temperature (CCT) (K)	4000
Color Rendering Index (CRI)	65
Luminous flux of light source (lm)	330 (1 LED module)
Light source efficacy (lm/W)	49
Light source useful life	50,000 h
Light source	LED: CitiLED–CLL010-0305A1-50KL1A1 Citizen

**Fig. 13.4** Luminous intensity distribution curves of lighting product

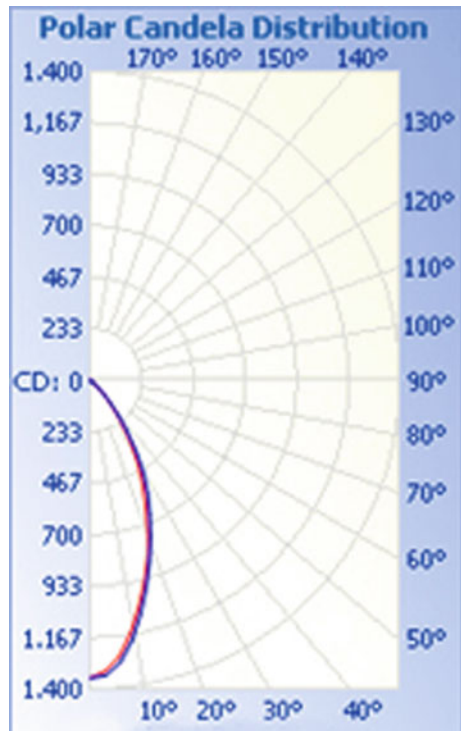

### 13.4.2 Goal and Scope

The first step to assess the LCA of a lighting product is to define the goal and scope of the LCA, which includes the definition of the ‘functional unit’ and the ‘system boundaries’ of the study. The goal of this study is to assess the total environmental impact of the lighting product, as well as to find out how the impact is allocated in the lighting product’s life cycle stages, and its components. The results of the assessment can be used to inform: (1) eco-redesign of the assessed lighting product, (2) eco-benchmarking, or (3) eco-design of new lighting products by considering the findings as a reference to reduce the environmental impact of new lighting products.

#### 13.4.2.1 Functional Unit

The functional unit specifies the function that is considered during the assessment. For example, the assessment may assume that the lighting product produces 200 lumens (lm) of light during 30,000 h.

The function of a lighting product is to produce a specific quantity and quality of light for a period of time. The quantity of light is measured with the luminous flux (lm) of the lighting product, and the quality of light is mainly measured with the CCT (K) and CRI (although other quality-related parameters such as luminance/glare, flicker and ease of use can also be considered). The period of time is determined by the useful life of the lighting product. Although both, quantity and quality, affect the electricity consumption and environmental impact of the lighting product, the quantity of light is the main contributor to the electricity consumption of the lighting product. The functional unit used in this assessment is considered as the production of 948 lm of light (quantity of light) of 4000 K, and 65 of CRI (quality of light) during 40,000 h, which is equivalent to the luminous flux (quantity), CCT and CRI (quality) of the lighting product assessed in this study (Table 13.1).

The period of time of the functional unit is determined by the useful life of the lighting product. LED-based lighting products’ useful lives are usually determined by the LED and/or control gear’s (e.g. driver) useful life. In this study, it has been considered as the LED useful life. The LED’s useful life is provided by LED suppliers’ lifespan datasheets, applying the TM-21-11 method (IES 2011). However, this approach should be adopted with caution, because, as it has been discussed in several studies (US DOE 2009a; Lumileds Holding B.V. 2018) LED lifespan datasheets cannot be used as a proxy to estimate the lifespan of a LED-based lighting system. This is due to the fact that LEDs work as part of a lighting system in a real-life environment, their behavior may be different to the same LEDs tested outside lighting systems in controlled-lab environments. This has been confirmed in several studies, which show that LED-based lighting products may fail before their expected LED useful life (US DOE 2009b; Casamayor et al. 2015). This suggests the need to consider several possible useful life scenarios in LCAs of lighting products, based on the assumption of a short (1,000 h), medium (15,000 h) or long (40,000 h) useful life, to



account for early failure, random failure or change for upgrade, or long-term failure due to natural wear out of components. These possible scenarios are examined in the ‘Sensitivity analysis and scenarios’ (Sect. 13.4.6).

### 13.4.2.2 System Boundaries

Once the functional unit has been defined, it has to be defined the ‘system boundaries’ which specify the boundaries of the assessment, or in other words, which product life cycle stages and processes will be considered in the assessment. The product life cycle stages considered in this assessment include extraction and production of materials, manufacture, transport, use, and end of life of the lighting product (Fig. 13.5).

To conduct the LCA, the following considerations related with the systems boundaries have been taken into account:

- **Manufacturing:**

The transport of the material from the extraction site to the material production factory, and from the material production factory to the product assembly factory has been taken into consideration in the assessment. The ‘Market datasets’ option from Ecoinvent 2016 database have been used when selecting materials and processes in the assessment, to account for market composition and transportation from material extraction to the assembly factory. The 100% recycled PET used in the assessment has considered the material loss of the recycling processes, as well as the energy used in the transport and processing of the re-used PET material.

- **Use:**

The maintenance during the ‘use’ stage of the lighting product has not been considered in the assessment. Maintenance may cause extra impact during the ‘use’ stage, but it can also extend the useful life of the lighting product and improve the lighting product efficacy (e.g. clean optical elements produce more light output). Although the lighting product can be dimmed, which, in theory, should reduce the electricity consumption, this has not been considered in the assessment because it is not known how much electricity can be saved by the integration of dimmers in LED-based lighting products.

- **Transport:**

This stage comprises the transport of the lighting product from the factory based in Spain to the final consumer in the Netherlands. For the transport from the factory in Spain to the retailer in the Netherlands, the total transport distance assumed is 2,063 km. This distance comprises two sub-distances: The transport from the lighting manufacturer factory to the Netherlands national point of the logistics company, 1,874 km, using 40 Ton lorries, and the transport from the Netherlands national point of the logistics company to the retailers, 189 km, using 3.5-7.5 Ton lorries.

**Fig. 13.5** System boundaries

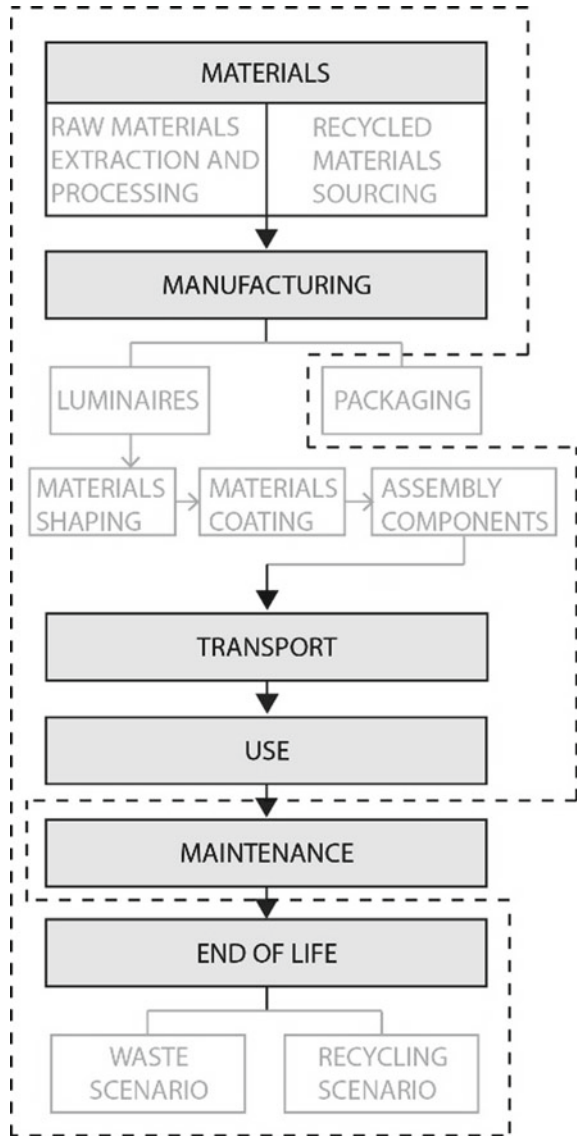

- End of Life:

The end of life of the lighting products is difficult to predict, because this depends on consumer’s personal disposal decisions, that is why is necessary to create possible scenarios. Two main possible end of life scenarios, domestic bin and recycling centre, are considered in this research. The ‘domestic bin’ scenario assumes that the lighting product is disposed in a household bin and the household municipal waste process is followed. The ‘recycling centre’ scenario assumes that the lighting product is taken

to a recycling centre where it is recycled. In this scenario it is assumed that 80% of the lighting product is recycled and that 20% of the material is not recycled and is processed via the municipal waste scenario.

### ***13.4.3 Life Cycle Inventory***

At this stage, the Bill of Materials (BoM) of the lighting product has to be input into Simapro software to conduct the assessment. In order to obtain the BOM it is necessary to disassembly fully the lighting product and weight their components. It is also necessary to identify the manufacturing processes required to produce each component. The materials and processes data utilised in the assessment are selected from the recycled content model of Ecoinvent V.3.2 database (Ecoinvent 2018) from the software list of databases.

### ***13.4.4 Life Cycle Impact Assessment Method and Scenarios***

#### **13.4.4.1 Life Cycle Impact Assessment (LCIA) Method**

This phase of the LCA is aimed at assessing and interpreting the LCI (i.e. substances from BOM) collected in the previous phase. The LCIA usually consist of the following steps: (1) classification, (2) characterization, (3) normalization and (4) weighting of LCI substances. These steps are performed automatically once a LCIA method has been selected from the list of possible LCIA methods available in Simapro. In this LCA, it was selected the LCIA: ReCiPe V1.12 (Goedkoop et al. 2013). ReCiPe allows the provision of results in a broad set of midpoint and endpoint environmental impact indicators, which can satisfy: (1) transparency of results, through 18 midpoint indicators, for users who want weighting-free results, and (2) weighted simplified results in more meaningful impact categories through three endpoint indicators. The Hierarchist (H) version was selected because it is the 'recommended' option of this method, which is based on the most common policy principles with regards to time-frame (Goedkoop et al. 2013).

ReCiPe midpoint (H) shows the results based on eighteen midpoint impact categories: Climate change, Ozone depletion, Terrestrial Acidification, Freshwater Acidification, Marine Eutrophication, Human Toxicity, Photochemical Oxidant Formation, Particulate Matter Foundation, Terrestrial Ecotoxicity, Freshwater Ecotoxicity, Marine Ecotoxicity, Ionizing Radiation, Agricultural Land Occupation, Urban Land Occupation, Natural Land Transformation, Water depletion, Metal Depletion, and Fossil depletion. Recipe endpoint (H) shows the results based on three endpoint impact categories: Human health, Ecosystems, and Resources Availability.

**Table 13.2** Scenarios description

Scenarios	Country where is manufactured	Country where is used	Useful life (h)	Country where is distributed	Country where is disposed	Type of end of life
S1	Spain	Netherlands	1,000	Netherlands	Netherlands	Domestic bin
S2	Spain	Netherlands	1,000	Netherlands	Netherlands	Recycling
S3	Spain	Netherlands	15,000	Netherlands	Netherlands	Domestic bin
S4	Spain	Netherlands	15,000	Netherlands	Netherlands	Recycling
<i>S5 (base)</i>	<i>Spain</i>	<i>Netherlands</i>	<i>40,000</i>	<i>Netherlands</i>	<i>Netherlands</i>	<i>Domestic bin</i>
S6	Spain	Netherlands	40,000	Netherlands	Netherlands	Recycling

#### 13.4.4.2 Scenarios

The assessment has been conducted based on six possible scenarios (Table 13.2) to check the sensitivity (i.e. consistency) of the results when using different possible scenarios. The most probable scenario has been considered as the base-case (main) scenario, where the lighting product is used for 40,000 h, distributed, and disposed (in a domestic bin) in the Netherlands, and disposed in a domestic bin.

### 13.4.5 Interpretation of Results of the Base-Case Scenario

This section shows (Figs. 13.6, 13.7, 13.8 and Table 13.3) the LCA results based on the base-case scenario (scenario 5).

#### *Overall Results*

Figures 13.6 13.7, 13.8 and Table 13.3 show the environmental impact results (using midpoint and endpoint environmental impact indicators) of the lighting product.

#### *Results of Life Cycle Stages*

Figure 13.8 and Table 13.3 also show the environmental impact for each life cycle stage of the lighting product using midpoint environmental impact indicators. The results reveal each life cycle stage's contribution to the total impact of the lighting product as follows:

- 'Use' is the life cycle stage with the highest impact. The impact of this life cycle stage is caused by the electricity consumed by the luminaire, which mainly affects the climate change, ozone depletion, natural land transformation, fossil depletion and ionizing radiation impact categories.

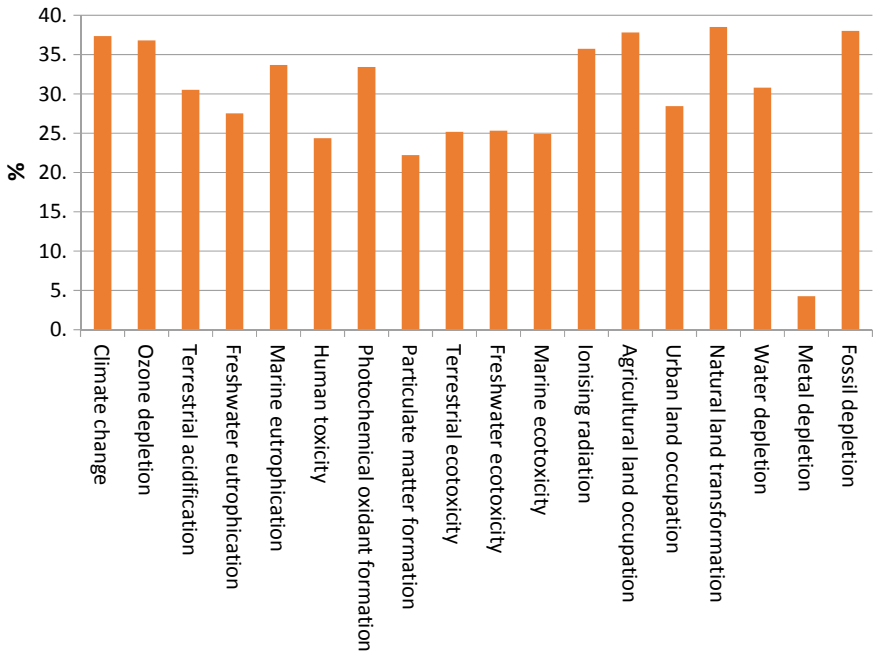

Fig. 13.6 Environmental impact (midpoint indicators) per impact category in the base-case scenario

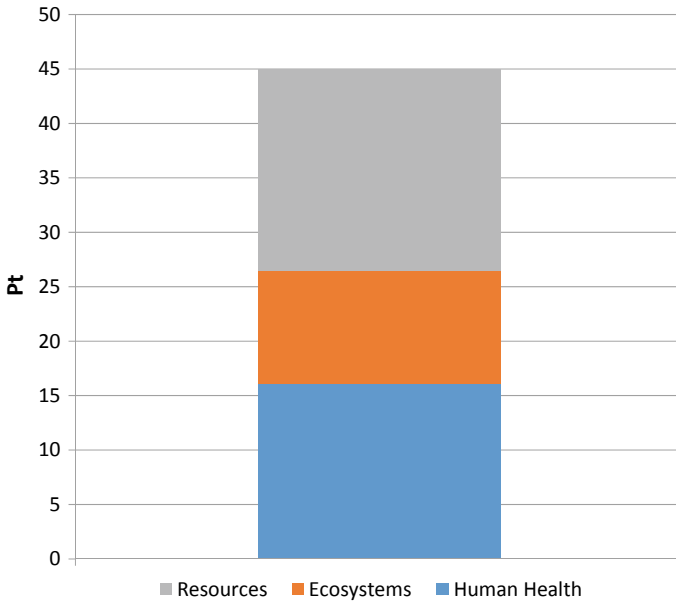
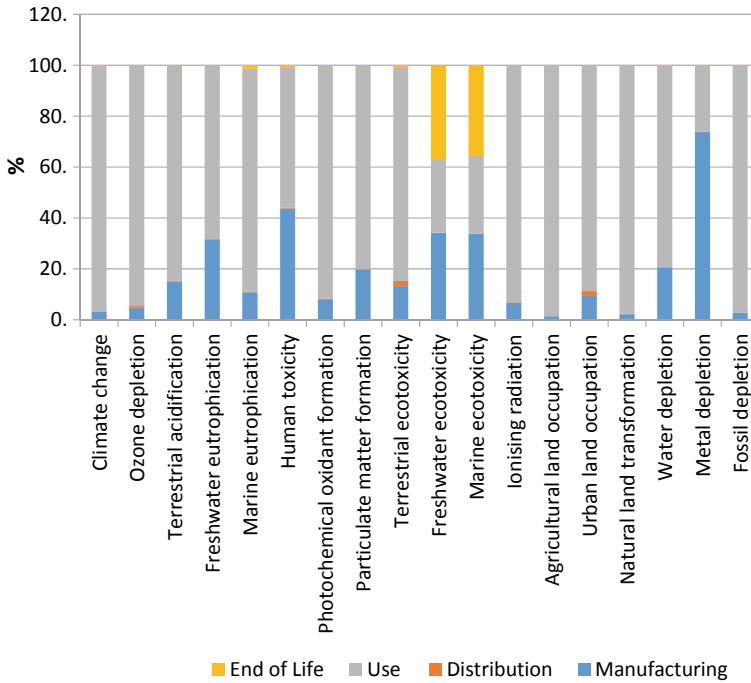

Fig. 13.7 Environmental impact (endpoint indicators) per impact category in the base-case scenario



**Fig. 13.8** Environmental impact (midpoint indicators) of each life cycle stage in the base-case scenario

- ‘Manufacturing’ is the life cycle stage with the second highest impact on average (i.e. in almost all impact categories). The main impact categories that contribute to the impact in this life cycle stage is metal depletion and human toxicity.
- ‘End of life’ is the life cycle stage with the third highest impact and represents an imperceptible impact in all the impact categories, except in freshwater ecotoxicity and marine ecotoxicity, which represent 37% and 36% of the total impact of those categories in the product life cycle.
- ‘Transport’ is the life cycle stage with the lowest impact and is barely perceptible in the total impact. The impact categories that contribute more to the impact produced in this life cycle stage are Urban Land Occupation and Terrestrial Ecotoxicity, representing about 2%.

In the manufacturing stage, the processes with the highest impacts are: (1) Production of Aluminum alloy (47%), (2) Production of recycled PET (12%), and (3) Injection molding process (5%).

**Table 13.3** Total and life cycle stage environmental impact (midpoint indicator) in the base-case scenario

Impact category	Unit	Total	Manufacturing	Transport	Use	End of life
Climate change	kg CO <sub>2</sub> eq	500	16.4	0.574	482	1.67
Ozone depletion	kg CFC-11 eq	2.43E-5	1.2E-6	1.05E-7	2.3E-5	1.75E-8
Terrestrial acidification	kg SO <sub>2</sub> eq	0.657	0.0979	0.00184	0.557	0.000581
Freshwater eutrophication	kg P eq	0.0562	0.0178	5.29E-5	0.0383	6E-5
Marine eutrophication	kg N eq	0.0437	0.00471	8.22E-5	0.0383	0.000597
Human toxicity	kg 1,4-DB eq	63.8	27.9	0.158	35.1	0.657
Photochemical oxidant formation	kg NMVOC	0.781	0.0631	0.00235	0.715	0.0008
Particulate matter formation	kg PM <sub>10</sub> eq	0.259	0.0508	0.0016	0.207	0.000267
Terrestrial ecotoxicity	kg 1,4-DB eq	0.0119	0.00158	0.000238	0.00999	0.000126
Freshwater ecotoxicity	kg 1,4-DB eq	10.2	3.5	0.00551	2.97	3.77
Marine ecotoxicity	kg 1,4-DB eq	9.16	3.09	0.00642	2.8	3.26
Ionising radiation	kBq U235 eq	20.3	1.35	0.0446	18.9	0.00595
Agricultural land occupation	m <sup>2</sup> a	50.3	0.715	0.00916	49.6	0.00233
Urban land occupation	m <sup>2</sup> a	2.27	0.213	0.0432	2.01	0.00214
Natural land transformation	m <sup>2</sup>	0.103	0.00233	0.000226	0.101	-1.01E-5
Water depletion	m <sup>3</sup>	1.26	0.26	0.00207	0.993	0.0024
Metal depletion	kg Fe eq	12.3	9.1	0.0229	3.21	0.00578
Fossil depletion	kg oil eq	167	4.64	0.209	163	0.0176

### 13.4.6 Sensitivity Analysis

The sensitivity of the results is analysed using six scenarios (Table 13.2), to know what the environmental impact of the lighting products would be if they had different useful lives and end of lives.

The sensitivity analysis and scenarios are mainly focused on the use stage (useful life) because it is the life cycle stage with the highest impact in the base-case scenario, and one of the key factors that affect the environmental impact in the use stage is the useful life of the lighting product. The useful life is influenced by manufacturing faults, operating conditions, and lighting product's design (US DOE 2009a). A 'lumen depreciation long-term performance study' carried out by US Department of Energy (US DOE 2009b) showed that 5 out of 26 LED-based lighting products failed to produce their intended light output, which is below 70% of its light output, also called L70, within the first 1,000 h. This indicates that LED-based lighting products do not always have the useful life estimated by the LED useful life, provided by the LED suppliers, but rather follow the typical 'bathtub' curve (Fig. 13.9) of electronic products (Osram 2008), which shows three main typical periods: 'Early failure period', 'spontaneous failure period' and 'wear out period'.

To consider the three typical periods (Fig. 13.9) observed in electronic products, three useful life scenarios were assumed: 1,000, 15,000, and 40,000 h. The scenario of 1,000 h assumed an early failure due to manufacturing faults, the scenario of 15,000 h assumed a random failure or the substitution of the lighting product due to technology/aesthetics upgrade, and the scenario of 40,000 h assumed an 'ideal' useful life, based on the average useful life of LEDs provided by LED suppliers. It is an 'ideal' scenario because this figure is provided by the LED supplier based on long-term extrapolations of shorter temporal tests conducted in lab ideal controlled operating conditions (US DOE 2009a).

The scenarios also assumed the possibility that the lighting product could be disposed in the domestic bin or in the recycling centre, which were two possible scenarios for this lighting product. Figure 13.10 shows the total environmental impact of the lighting product assuming six scenarios, (i.e. the base-case scenario and five additional scenarios).

**Fig. 13.9** Bathtub curve: failure rate over time

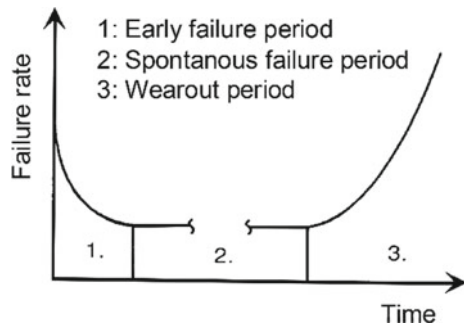



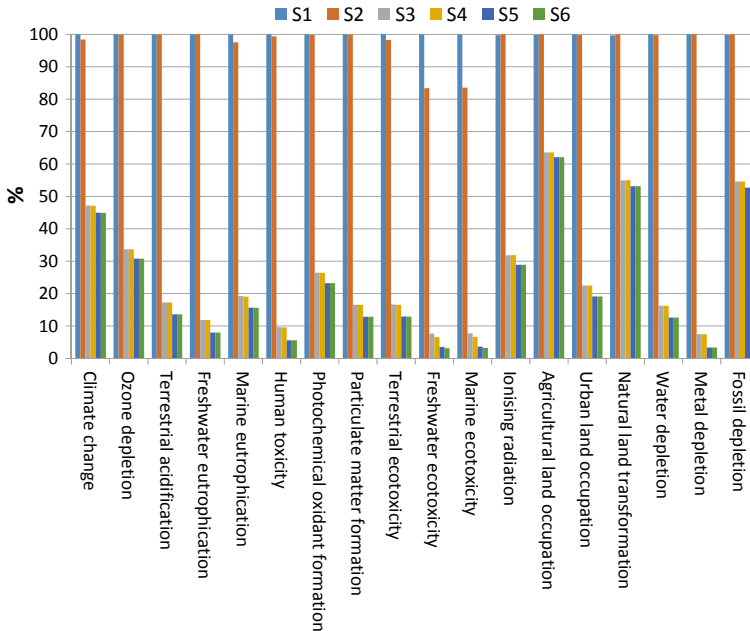

Fig. 13.10 Total environmental impact (midpoint indicators) in scenarios 1-6

The life cycle stage with the highest impact in all scenarios is the use stage, except scenarios S1 and S2. In these scenarios, the lighting product is assumed to have the shortest useful life, (e.g. 1,000 h.), and the manufacturing stage had the highest impact, followed by the use stage.

Scenario 1 (S1: 1,000 h. - domestic bin) has the highest environmental impact, followed by scenario 2 (S2: 1,000 h. - recycling). S2 has a slightly lower impact than S1 because the lighting product is recycled at the end of life. The reason for the minimal difference in impact between S1 and S2 is because the end of life stage plays a minor role in the total impact of the lighting product. S1 and S2 have the highest impact because the lighting product has the shortest useful life (1,000 h), which means that 40 lighting products have to be manufactured to provide the same functional unit (i.e. 40,000 h.). That is why the environmental impact in all impact categories of S1 and S2 is produced mainly in the manufacturing stage.

Scenario 6 (S6: 40,000 h. - domestic bin) has the lowest environmental impact, followed by Scenario 5 (S5: 40,000 h. - recycling centre). S5 has a slightly higher impact than S6 because the lighting product of S5 is not recycled (e.g. domestic bin scenario, at the end of life). S5 and S6 have the lowest impact amongst all the scenarios because the lighting product of S5 and S6 have the longest useful life (40,000 h). The main environmental impact in S5 and S6 occurs during the use stage, followed by the manufacturing stage. The lighting product assessed produces 60% more CO<sub>2</sub> in S1 than the base-case scenario S5.

## 13.5 Eco-Design Recommendations

The LCA results can be used to inform design decisions as follows: (1) It can inform the product developer about the life cycle stages and components with the highest environmental impact, and (2) It can inform the product developer how different possible scenarios affect the total and each life cycle stage impact. This can help the product developer to know where eco-design strategies must to be focused on. The LCA results can also be used to compare or benchmark the environmental impact assessment of this lighting product with other lighting products, or a eco-redesigned version of the same product to compare environmental performance improvements. It can also be used to inform the certification of eco-labels, as environmental performance information is usually required.

In the example illustrated in this chapter, the LCA results reveal that the life cycle stages with the highest impact are the use and manufacturing stages, which means that these life cycle stages should be given priority when applying eco-design strategies. The main eco-design strategies that can be implemented to reduce the impact of the use and manufacturing stages of the lighting product are the following:

In the use stage: (a) Increase the luminous efficacy of the lighting product, (b) Integrate dimmers, and (c) Integrate smart controls, such as occupancy sensors, to reduce the energy used during the use stage.

In the manufacturing stage: (a) Reduce the amount of virgin materials used, especially critical materials, or use recycled materials as much as possible, and (b) Avoid or reduce the amount of manufacturing processes which produce a high environmental impact.

The end of life and, especially, the transport stages produce a minimal environmental impact, so the eco-design strategies should firstly be focused on the use and manufacturing stages, and then consider the end of life and transport stages if resources (e.g. time, money) allows this.

In the scenario where the lighting product has a short useful life (e.g. 1,000 h.), manufacturing is the life cycle stage with the highest impact, rather than the use stage. This scenario may happen in lighting products with production faults or those utilised in extreme operating conditions. In this case, eco-design strategies have to be focused on the manufacturing stage first, followed by the use stage.

## 13.6 Limitations of LCA

It is important to point out that the LCA methodology presents some limitations with regards to the consideration in the assessment of some lighting product features, which contribute to reduce the environmental impact of the LCA results. Features such as durability, light control, easy disassembly, and recyclability differ between lighting products and it should be possible to consider them in the LCA accurately

and realistically without making assumptions, as these may affect the environmental impact results of each lighting product significantly. Usually, durable lighting products, which provide total light control, are easy to dismantle (to facilitate repair, upgrade and recycling), and are fully recyclable, should have less environmental impact than lighting products that do not present these characteristics, and, yet, the consideration of these features in a LCA presents the following challenges:

#### *Durability*

The durability of a lighting product can be considered in a LCA by adopting a longer or shorter useful life (i.e. functional unit) of the lighting product in the assessment. However, if there is no factual data about the useful lifespan of the lighting product to be assessed, given by the suppliers, making assumptions about its useful lifespan may result in invalid or misleading results.

#### *Light Control*

Light direction and light quantity control allow saving energy, and hence diminish environmental impact, enabling the user to use the exact amount of light needed, where it is needed. Nevertheless, this feature cannot be considered, unless we know how much energy can be saved when using lighting products that allow light control. If there is no empirical data which can provide information about the electricity savings of lighting products that have specific light controls, then different assumptions must be made for each lighting product, which may affect the validity of the results.

#### *Easy Disassembly*

Easy disassembly can facilitate repairing, upgrading and maintaining the lighting product, thus extending its useful life. However, it is difficult to quantify how much the useful life is extended in lighting products which can be dismantled easily. It is necessary to understand how different disassembly features affect the useful lifespan of lighting products, and that lighting product manufacturers provide information about the useful life of their products, so a realistic useful life can be input in the functional unit of the LCA.

#### *Recyclability*

It is difficult to consider in the LCA what percentage of the lighting product will be recycled at the end of life when considering a recycling scenario, because it is unknown how the lighting product will be disposed at the end of life by the end user, and where (which country/area of the country) it will be disposed. More empirical data about how end users dispose their lighting products in each country/region would help to carry out LCAs based on 'average' empirical data instead of data based on complete assumptions, which in turn would provide more realistic LCA results. It would be easier to estimate what percentage of material will be recycled.

To provide an accurate and realistic LCA of lighting products, is necessary to have access to empirical data on such aspects as the useful life of the lighting product in normal operative conditions and how much energy is saved when using light controls. It is also necessary to understand how different lighting products architectures affect

their disassembly, repair or upgrade capacity, and how these, in turn, may affect their useful lifespan. It is also important to understand and have empirical data about the recycling potential of a product based on its composition, architecture, and recycling facilities in each country, so this information can be used in the LCA. All these features significantly affect the use stage (i.e. the life cycle stage with the highest impact), so the understanding of how these features may affect the LCA results is crucial to obtain more realistic LCA results of lighting products. Some of these features (e.g. recyclability) are related with the end of life stage, because lighting products that are easy to dismantle and are highly recyclable, should have lower impact at the end of life stage.

**Acknowledgements** The authors acknowledge the financial support received from the financial support from the European Commission's CIP-EACIECO-INNOVATION programme for the Eco-lights project (grant no. ECO/11/304409). The authors also would like to thank Ona Product S.L. ([www.ona.es](http://www.ona.es)) for providing their lighting products, as well as other necessary product life cycle information for this study.

Original source of the contents: Casamayor, J. L., Su, D., & Ren, Z. (2017). Comparative life cycle assessment of LED lighting products. *Lighting Research & Technology*, (0), 1–26. <https://doi.org/10.1177/1477153517708597>. Copyright © SAGE Publications 2017.

## References

- Casamayor, J., Su, D., & Sarshar, M. (2015). Extending the lifespan of LED-lighting products. *Architectural Engineering and Design Management*, 11, 105–122.
- Charter, M., & Tischner, U. (2001). *Sustainable solutions: Developing products and services for the future*. Sheffield: Greenleaf Publishing.
- Ecoinvent Database. (2018). Retrieved March 18, 2018, from <https://www.ecoinvent.org/home.html>.
- Energy Star. (2018). Retrieved March 18, 2018, from [https://www.energystar.gov/products/spec/luminaires\\_specification\\_version\\_2\\_0\\_pd](https://www.energystar.gov/products/spec/luminaires_specification_version_2_0_pd).
- European Commission (EC). (2018). CE marking. Retrieved March 18, 2018, from <http://ec.europa.eu/growth/single-market/ce-marking/>.
- Finnveden, G., & Moberg, A. (2005). Environmental systems analysis tools-An overview. *Journal of Cleaner Production*, 13, 1165–1173.
- Goedkoop, M. J., et al. (2013) *ReCiPe 2008: A Life Cycle Impact Assessment method which comprises harmonised category indicators at the midpoint and the endpoint level: Report I: Characterisation*. Report, Ministry of housing, spatial planning and environment (VROM), The Netherlands.
- Hur, T., et al. (2005). Simplified LCA and matrix methods in identifying the environmental aspects of a product system. *Journal of Environmental Management*, 75, 229–237.
- IEC (International Electro Technical Commission). (2013). IEC 60529:1989+A1:1999+A2:2013: Degree of protection provided by enclosures (IP Code). Retrieved March 18, 2018, from [https://global.ihs.com/doc\\_detail.cfm?&rid=Z57&mid=5280&item\\_s\\_key=00035807](https://global.ihs.com/doc_detail.cfm?&rid=Z57&mid=5280&item_s_key=00035807).
- IES (Illuminating Engineering Society). (2011). *Projecting long term lumen maintenance of LED light sources*. New York: IES.
- International Organization for Standardization (ISO) 14040:2006. (2006a). Environmental management-Life cycle assessment-Principles and framework. Retrieved March 18, 2018, from [http://www.iso.org/iso/catalogue\\_detail?csnumber=37456](http://www.iso.org/iso/catalogue_detail?csnumber=37456).

- International Organization for Standardization (ISO) 14044:2006. (2006b). Environmental management-Life cycle assessment-Requirements and guidelines. Retrieved March 18, 2018, from [http://www.iso.org/iso/catalogue\\_detail?csnumber=37456](http://www.iso.org/iso/catalogue_detail?csnumber=37456).
- Jensen, A. A., et al. (1997). Life Cycle Assessment (LCA). A guide to approaches, experience and information sources (Environmental series n6). Brussels: European Environment Agency.
- Lewis, H., et al. (2001). *Design and environment-a global guide to designing greener goods*. Sheffield: Greenleaf Publishing Limited.
- Lumileds Holding B. V. (2018) Evaluating the lifetime behaviour of LED systems: White paper. Retrieved March 18, 2018, from <http://www.lumileds.com/uploads/167/WP15-pdf>.
- Malmqvist, T. (2004). *Real estate management with focus on the environmental issues*. Licentiate Thesis., Royal Institute of Technology (KTH).
- Mcaloone, T., & Bey, N. (2009). *Environmental improvement through product development—a guide*. Denmark: Danish Environmental Protection Agency and Confederation of Danish Industry.
- Ona Product S.L. (2018). Retrieved March 18, 2018, from <http://ona.es/>.
- Osram. (2008). Reliability and lifetime of LEDs—application note. Retrieved March 18, 2018, from <http://catalog.osram-os.com/>.
- PRè Consultants. (2018). Simapro software. Retrieved March 18, 2018, from <http://www.pre-sustainability.com/simapro>.
- Sustainable Minds. (2018). Sustainable Minds software. Retrieved March 18, 2018, from <http://www.sustainableminds.com/>.
- ThinkStep. (2018). Gabi software. Retrieved March 18, 2018, from <http://www.gabi-software.com/uk-ireland/index/>.
- US DOE. US Department of Energy. (2009a) LED measurement series: LED luminaire reliability. Retrieved March 18, 2018, from [http://cool.conservation-us.org/byorg/us-doe/luminaire\\_reliability.pdf](http://cool.conservation-us.org/byorg/us-doe/luminaire_reliability.pdf).
- US DOE. US Department of Energy. (2009b). Solid-State Lighting CALiPER Program-Summary of results: Round 9 of product testing. Retrieved March 18, 2018, from <http://www1.eere.energy.gov/buildings/ssl/reports.html>.
- Wrisberg, N., et al. (2002). *Analytical tools for environmental design and management in a systems perspective*. Dordrecht: Kluwer academic Publishers.

# Chapter 14

## Comparative Life Cycle Assessment of Raised Flooring Products



Shuyi Wang, Daizhong Su, Shifan Zhu, and Qianren Zhang

**Abstract** A new type of raised flooring product made of composite materials has been developed. The life cycle assessment (LCA) of the product is presented in this chapter. In the assessment, the new product is compared with two existing products, cement injected steel flooring product and chipboard-based flooring product. A cradle to grave LCA is carried out, and all life cycle stages are taken into consideration except the Use and Maintenance stages. The LCA results reveal that (1) the new product has the least environmental impact (466.67 point) in comparison with the cement injected steel flooring product (1941.99 point) and chipboard-based flooring product (1846.94 point) which are about four times of the new product's environmental impact, and (2) the production is identified as the key stage of all the three products in term of environmental impact. Improvement opportunities are proposed, limitations of the new raised flooring product and the comparative LCA study are discussed at the end of the paper. There has been limited research regarding the LCA of flooring products, and, hence, this research made a valuable contribution to fill the gap.

**Keywords** Flooring product · Life cycle assessment (LCA) · Eco-design · Product design

---

S. Wang (✉) · D. Su

School of Architecture, Design and the Built Environment, Advanced Design and Manufacturing Engineering Centre, Nottingham Trent University, Nottingham, UK  
e-mail: [shu.wang2015@my.ntu.ac.uk](mailto:shu.wang2015@my.ntu.ac.uk)

D. Su

e-mail: [daizhong.su@ntu.ac.uk](mailto:daizhong.su@ntu.ac.uk)

S. Zhu

Department of Product Design, College of Mechanical and Electrical Engineering, Harbin Engineering University, Harbin, China  
e-mail: [zhushifan@hrbeu.edu.cn](mailto:zhushifan@hrbeu.edu.cn)

Q. Zhang

Chongqing Polycomp International Corp., Chongqing, China  
e-mail: [zhangqianren@cpicfiber.com](mailto:zhangqianren@cpicfiber.com)

## 14.1 Introduction

Raised floor system, also known as access floor system, provides spaces underneath the floor for power cables easy installation and access in buildings, such as computer rooms (Marvin et al. 1984). The elevated space also permits proper ventilation which keeps the temperature safe for equipment operation. Raised floor systems provide more features such as heating, ventilation and air conditioning, which have made flooring of this kind widely applied in office buildings, data centers, and educational institutions. Studies have shown that raised floor systems produce a positive effect on minimizing the impact vibration during earthquakes and, help achieve green building certificate by increasing the energy-efficiency (Reynolds et al. 1998; Srinarayana et al. 2012). All these factors have increased the market demand for this type of products. China, USA and UK have become top three consuming and supplying countries of raised flooring products according to Alibaba and eBay. For example, in Jiangsu, a province of China, there are thousands of raised floor online suppliers which trade worldwide.

There are certain drawbacks of the existing raised floor products along their advantages, such as heavy weight and negative impact on the environment. The heaviness increases their transportation cost, aggravate burden on a building, and results in hardships in their mobility. Fewer producers have considered environmental aspects of the raised floor products from a life cycle perspective. Currently, waste raised flooring products have to send to landfill due to the less consideration of end-of-life treatment. Most of floor panels are non-detachable, some of the panel materials are non-biodegradable which raise serious concern to their disposal eco-systems. Therefore, it is necessary to address these problems in raised flooring products with consideration of environmental performance through their product lifecycle.

LCA is an effective tool which has been used to evaluate the environmental profile through product development and services for decades of years. It has also been constantly applied in eco-labeling scheme and environmental declarations (Baumann and Tillman 2004; ISO 2006a, b).

According to the literature, there is limited research regarding the LCA of flooring products, existing studies available in the literatures were focused on general flooring products, no literature is found on raised flooring products. In early years, studies were aimed at LCA comparison of floor covering materials to guide environmentally sound and emission free purchase (Potting 1995; Jönsson et al. 1997). Jönsson (1999) compared the environmental impact of three general flooring materials namely linoleum, vinyl and solid wood under the scenario of Sweden, of which Volatile Organic Compounds (VOCs) in use phase was considered. Based on a processed LCA, the study revealed that the solid wood flooring was the most environmentally preferable choice, followed by linoleum and vinyl, and the TVOCs emitted by floor coverings during the use phase are of much the same magnitude as the TVOCs emitted in the rest of their life cycle, except for solid wood flooring. Nicoletti et al. (2002) conducted a comparative LCA between conventional ceramic and marble tiles, in which key environmental impact categories were identified as well as

the hotspot life cycle phase of two flooring tiles, indicating that impacts of ceramic tile is over twice as bad as the marble tile, and improvement solutions for the two products were proposed. Reza et al. (2011) compared three kinds (concrete, clay and expanded polystyrene) of construction flooring systems based on AHP LCA and triple-bottom line criteria; according to the result, expanded polystyrene is the most environmentally sound flooring system amongst the three. A recent LCA case study (Sangwan et al. 2017) assessed the environmental impact of a ceramic tile supply chain, and the manufacture was identified as the key environmental impact stage. Geng et al. (2017) compared a kind of wood flooring with traditional ceramic tile from a greenhouse gas reduction and cost-effective points of view, which proved the advantages of wood flooring tile.

The existing studies discussed above focus on comparing environmental impact of general flooring materials to guide material selection, none of the LCA studies regarding comparison of raised flooring product through their whole life cycle. Additionally, some of the studies did not applying LCA software in early years and different evaluation methods were applied, of which are outdated, and the results gained may inaccurate.

This paper aims to identify a new eco-friendly raised flooring product by assessing and comparing its environmental impact with existing flooring products. The research conducted a study in LCA comparison of raised flooring products with step-by-step explanation and in-depth analysis. A novel raised flooring product was elaborated in detail for comparison, a cradle to grave LCA of the new and existing flooring products was carried out by employing openLCA software tool (GreenDelta, n.d.) with Ecoinvent database (Ecoinvent, n.d.). The assessment results were obtained and interpreted. At the end of the study, limitations of LCA assessment have been discussed and improvement techniques are proposed.

## 14.2 Raised Flooring Product

A traditional raised flooring product, as shown in Fig. 14.1, consists of a panel, a stringer, pedestals, and fasten members. The floor panel is the most important part in a raised floor system. Usually, a raised floor panel is rectangular shaped with dimensions 600 mm × 600 mm. The stringers are used to decentralize the weight on and the load of the panel, support the panel and connect the panel with pedestals; whether the stringer is required or not depends on the application (elevated height and loading requirement) of the raised flooring product. The pedestals are rigid adjustable columns(usually four pedestals in a floor modular)which are made of metal, and their height varies ranging from 51 to 1200 mm according to consumer preference. The elevated height for low profile raised floor is about 30–150 mm which is only used for cable wire configuration (NETFLOORUSA 2015).

There are two kinds of raised flooring structures which have been most widely used in the market: sandwich-structured panels and wood-based panels, such as F2 or F3 shown in Fig. 14.3. A sandwich-structured panel consists of metal tray, metal



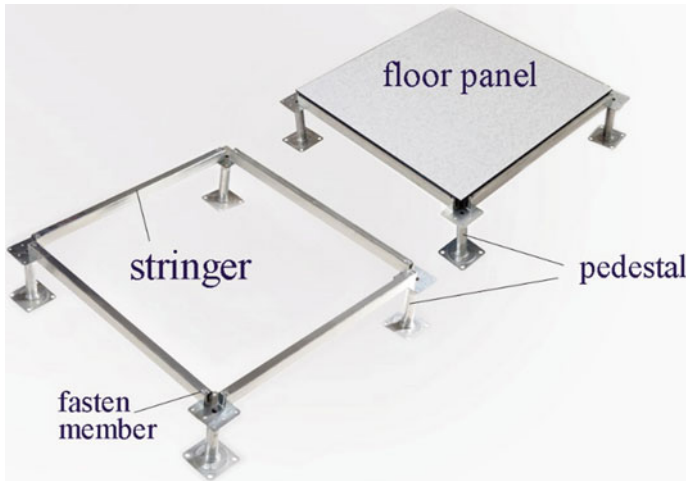
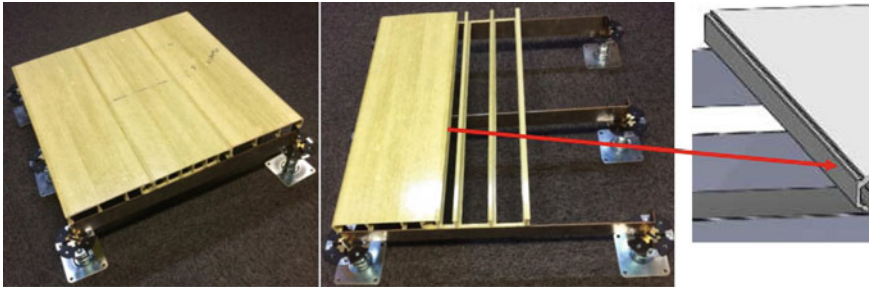

**Fig. 14.1** Raised flooring product

lid and core material. The core material could be cement, vegetable fiber and so forth. The panel is designed to embrace high strength, anti-corrosion, fire resistance and cost-effective features. For a wood-based panel, chipboard and plywood are the mostly chosen materials which are easy to get, cost effective and easy to manufacture. There are also glazed metal sheets placed upper and under side of the wood board. Different from metal sheets applied in a sandwich-structured panel, the sheets in wood-based panel are expected to isolate the wood board from exposure to the air to meet fire resistance and anti-corrosion requirement. The two kinds of raised flooring products become preferable choice for many applications such as laboratories and lecture rooms.

However, the existing raised flooring products have the following problems:

- The flooring products are too heavy. The most direct consequence is that the heavier the raised flooring products are, the more loading burden the building received. According to product catalogues of different raised floor suppliers, flooring product systems' weight in market is between  $34 \text{ kg/m}^2$  to  $63 \text{ kg/m}^2$  on average which are enormous burden to the building if applied in a large area. Besides, it aggravates the burden in transporting such panels in large scale, which increases the transportation cost as well as the consumption of fossil fuel. The heavy panel also can cause potential safety issue and hardship during installment, replacement, and removal (Tate 2013)
- Lacking consideration of environmental impact. Most suppliers have focused on panel ultimate load and aesthetics of floor cover. However, fewer raised floor producers take environmental aspect into consideration from a life cycle perspective. Most of the current waste raised flooring products have to send to landfill



**Fig. 14.2** New raised flooring product F1

or incineration due to the less consideration of end-of-life treatment and difficulties to separate the panel materials. Since many of the panel materials are non-biodegradable, there are worrying concerns of the consequence of the surrounding land and water after landfill of such waste.

To overcome the problems discussed above, a new raised flooring product, shown in Fig. 14.2, is developed by a China-UK collaboration project (Project Agreement 2015) and manufactured by Chongqing International Composite Material Co. LTD (CPIC) in China. As shown in Fig. 14.2, the new raised flooring product, so called F1 in this paper, comprises a glass fiber reinforced polymer floor panel, steel stringers (three parallel steel sheet) and four pedestals. The floor panel consists of 3 pieces of  $200 \times 600 \times 33$  mm modular tiles, each tile is all-in-one structured that is made from composite material only, thus there are no additional floor finish/cover or floor layers. The floor sample meet British Standard BSEN 12825:2001 (BSI 2001), PSA MOB PF2 PS and fire resistance standard UL 94 (MOB 1992). It can take ultimate load 8000 N with V1 fire resistance class. In addition, the product has the following novel features:

- **Light weight.** The product is approximately 50% or lighter than the existing flooring products. The panel is made of glass fiber reinforced polymer. This type of composite material has a higher strength to weight ratio in comparison with the materials used in other types of raised floor panels.
- **High strength.** The product compliances with a safety factor of Class 3 and Class A in deformation under the working Load, which shows the strong possible panel under BSEN Certification and PSA MOB PF2 PS (MOB 1992).
- **High usability and durability.** As shown in Fig. 14.2, due to the three-piece-tile ( $200 \text{ mm} \times 600 \text{ mm} \times 33 \text{ mm} \times 3$ ) panel design, the flooring product embraces more flexibility features through its life cycle. It is easy to transport, easy to handle and adjustment. Furthermore, there are no additional floor cover or finishing since the colour and texture are naturally within the composite material, and, hence, its maintenance during use becomes more flexible. Cover damage caused end-of-life is prevented, such as colour faded and edge curls. Thus, the product is designed to have a longer service life.

- Ease of manufacturing. Compares to common raised floor panels (sandwich panel), fabricate procedure of F1 can be simplified in manufacture stage since the flooring product is pultrusion fabricated. Manufacturing procedure such as injection and welding which are essential for traditional raised flooring production is eliminated.
- Ease of assembly and disassembly. There is a convex and concave chamfer edge on each side of one module tile (200 mm × 600 mm), the modular tile is interlock when a convex chamfer edge aligns with a corresponding concave chamfer edge, thus adhesives or fasten members are not required to join.
- Recyclable. The flooring panel is completely made from Glass Fiber Reinforced Polymer (GFRP). It is recyclable material which can be remanufactured into cement products (Yang et al. 2012; Strathclyde 2017). Stringer material is carbon steel which is reusable.

### 14.3 Life Cycle Assessment of Flooring Products

The comparative LCA was conducted by utilising software openLCA (GreenDelta n.d.) in line with Ecoinvent database (Ecoinvent n.d.). The three raised flooring products stated in Sect. 14.2 above were assessed and compared using ReCiPe method (PRè 2013).

openLCA is an open source Life Cycle sustainability assessment software. Other than paying expensive fees to access a LCA tool such as Simapro, Gaibe et al., openLCA is completely free which has gained wide applications. The software embraces an advanced underlying matrix and user-friendly interface, and, moreover, the calculation results have proved to be very similar to Simapro (Eisfeldt 2017). In this study, Ecoinvent was employed as the LCA data source. Consequential System Model is chosen for the study since the model emphasizes on assessing the consequences of different suppliers in product systems which fits better to the study. ReCiPe is the most recent and harmonized method, in which the environmental impacts are converted to 17 midpoint environmental categories and finally categorized in three endpoint impacts: Ecosystem, Human Health and Resources.

In the following sub-sections, after description of the three flooring products, their LCA is conducted following the procedure given in standards ISO 14040 (ISO 2006a) and ISO 14044 (ISO 2006b), including goal and scope definition, functional unit, system boundary, inventory data, results and interpretation.

#### 14.3.1 The Raised Flooring Products

As shown in Fig. 14.3, the flooring products under study are: composite material raised floor (F1), cement injected steel sandwich raised floor (F2) and, wood-based

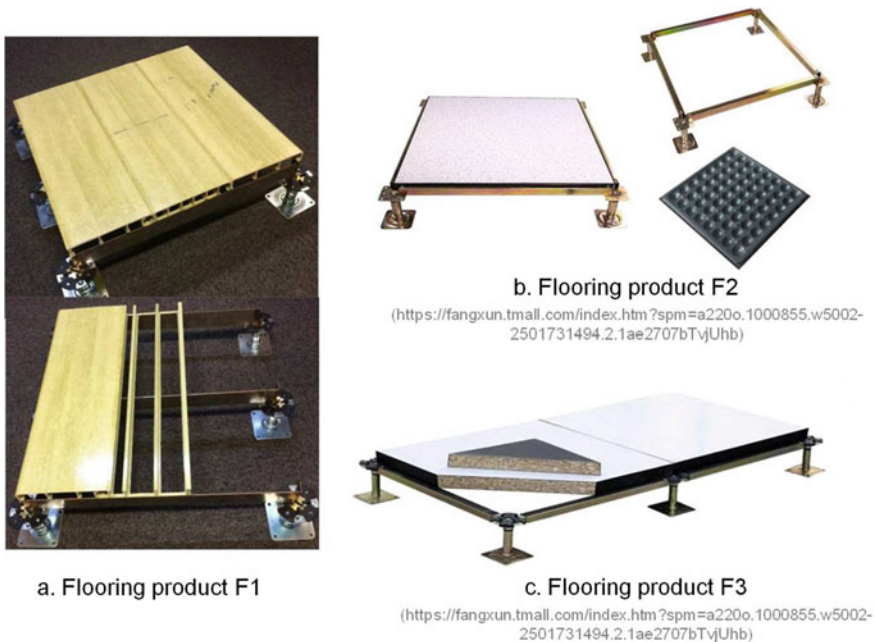

**Fig. 14.3** Raised flooring products under comparison

raised floor (F3). The two flooring products (F2, F3) were selected for comparison for the following reasons: (1) according to patent search and market investigation, chipboard-based panel and sandwich structure panel, especially with cement core, are most commonly used raised flooring panel type. (2) The three products have same configuration, which consists of a panel, a stringer and four pedestals. (3) The flooring products both manufactured in same region (China) and have a great market share according to the Internet search.

F1 is the proposed composite raised flooring product as presented in Sect. 14.2. F2 and F3 have been in the market for years, and the two flooring products are both manufactured in Changzhou (China) where most Chinese raised floor producers are located. F1 is the proposed composite raised flooring product as presented in Sect. 14.2. The technical parameters of three flooring products are summarized in Table 14.1.

F2 consists of a sandwich structured panel, a stringer, fasten members and pedestals. The panel is made of cement core wrapped with steel sheets and PVC finishing. The stringer is made from steel tube in a squared shape to support the panel as well as enhance the strength. There are three kinds of pedestal with different material and height which could be chose by customers with their preference.

Components of F3 are the same as its counterpart F2, however, this type of flooring panel is mainly made from wood fiber pressed board in special thickness (40 mm). To ensure the fire resistance and strength performance, steel sheets are placed (glued)

**Table 14.1** Technical Parameter of flooring products under comparison

	F1	F2	F3
Weight (panel and stringer)	11.76 kg	24.9 kg	24.5 kg
Component	Panel, stringer, pedestals	Panel, stringer, pedestals	Panel, stringer, pedestals
Dimension (mm)	600 × 600 × 33	600 × 600 × 35	600 × 600 × 40
Material	Glass fiber reinforced polymer, carbon steel sheet	Cement(core), steel sheet, PVC, rubber, steel tube	Wood (fiberboard), steel sheet, PVC, rubber, steel tube
Concentrated load	≥3000 N	≤3000 N	≥3000 N
Ultimate loads	≥8000 N	≤8000 N	≥8000 N
Fire resistance	V1	V1	V1

on the top of the chipboard and underneath it, a printed PVC sheet is placed on the top of the panel as finishing, the four edges are sealed with conductive rubber. For stringer and pedestals, the materials are both galvanized steel.

### 14.3.2 Goal and Scope of the LCA

The goal of this LCA study is to evaluate the environmental impact of the chosen flooring products through the product's whole lifecycle to identify the key environmental impact stages or processes, and to compare the environmental performance of the new raised flooring products with the two existing ones. The results can be used to identify opportunities in improving the environmental performance of the flooring products, such as eco-design and referencing in decision-makings or benchmarking of eco declarations.

### 14.3.3 Functional Unit

The function of the raised flooring product is to provide elevated support and sufficient spaces underneath the floor in a given unit area. Since the three raised flooring products have a same panel dimensions, the function unit is equal with the three products. Thus, the functional unite defined under this study is 100 items, one item includes a panel and a stringer of the three products.

### 14.3.4 System Boundary

The stages throughout flooring product’s life cycle including raw material acquisition, manufacture, packaging, distribution (transportation) and end-of-life treatment are within the system boundary under study. Use phase along with maintenance during the product’s service life are excluded from the assessment boundary, because information of those activities is out of reach. System boundary of this study is illustrated in Fig. 14.4 and further detailed below.

**Fig. 14.4** System boundary of the comparative LCA study

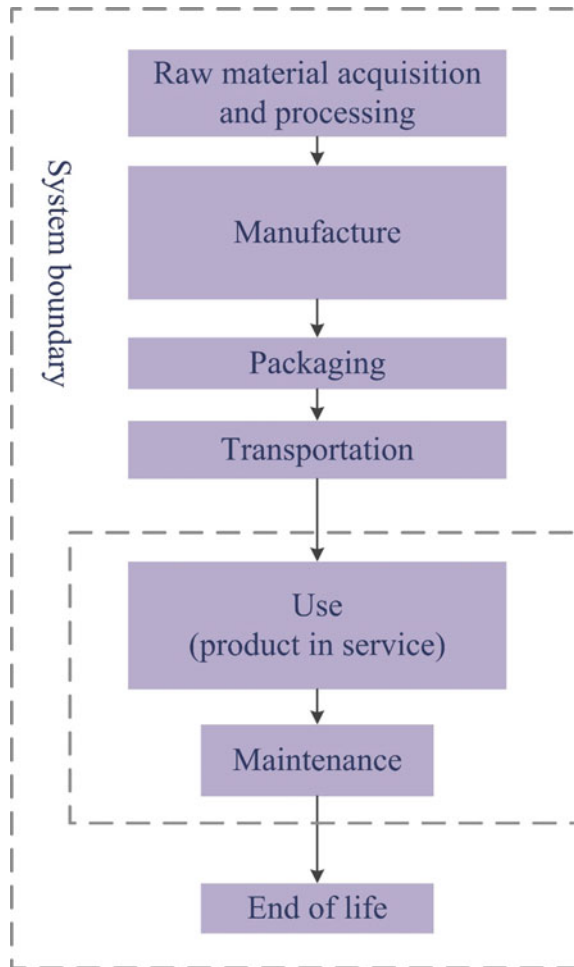

#### **14.3.4.1 Manufacturing**

Raw material acquisition (including chemical use during pretreatment, energy consumption, transportation from extraction to site-mill-distribution) was taken into consideration in manufacture stage. Procedure related to environmental impact throughout fabrication, such as use of materials, electricity, waste produced during manufacturing, and emissions are considered and assessed; the transportation during manufacture phase also is also considered within the boundary. Nevertheless, the production of pedestals was excluded from the boundary, as pedestal is a standard component used in all raised flooring products considered in the LCA.

#### **14.3.4.2 Packaging**

The packaging phase is included in the boundary since packaging stage plays a vital role in contributing product's environmental impact through the life cycle. It also helps in identifying the opportunity towards improvement alternatives. Packaging for F1 was calculated with referencing international transportation methods. It is assumed that the flooring products are packaged with folding boxboard, plastic, as well as wooden pallet for mass transportation. Packaging data of F2 and F3 are acquired by measuring the final products' packaging which is offered from the producers.

#### **14.3.4.3 Transport**

In the transportation stage, the transport activity through product distribution is taken into consideration. In this study, F1 is manufactured and packaged in China (Chongqing) then transported to the retailer in UK (London). The total delivery distance between the two countries is 11477 km via direct freight train. F2 and F3 are both produced in Changzhou (China) thus assumed to have a same transport routes: freight road transport from Changzhou to Yiwu (3541 km) then transport to UK via freight train (12451 km).

#### **14.3.4.4 End-of-Life**

The end-of-life phase is considered in system boundary; however, the end-of-life scenario of flooring product is hard to predict as it depends on user's decision on treating wasted floors. It is assumed that the end-of-life (EoL) scenarios are: the EoL floor panel of F1 will be sent to re-manufacturers to make cement products (Yang et al. 2012; Strathclyde 2017). However, panel material of either F2 or F3 is made from layer-based material or mixed material with chemicals. These kinds of material are bounded together as a whole with adhesives, and consequently cannot be detached for recycle or reuse. Thus, EoL for panels of F2 and F3 will be landfilled after their

use life. The other parts of the floor system such steel stringer, is considered going through the normal recycle/reuse rout of steel waste.

### **14.3.5 Inventory Data**

The bill of materials of three products is listed in Table 14.2. The floor panel sample of F1 was manufactured by Chongqing International Composite Material Co. LTD (CPIC) in China, thus input-output data such as material use, energy consumption during production and wastes were acquired in the factory. To collect data as well as learn the manufacturing procedure, a field study was conducted includes interviewing engineers and staff on the plant and measuring the product on site. Transport data was obtained according to the distance from Chongqing (China) to London (UK); EoL treatment data was obtained with the assumption that 80% of panel material would be sent to recycle and 20% would take to landfill and, all stringer material will be reused. The bill of materials and related mass of F2 and F3 are acquired by measuring the final products, as well inquiring the producer. Method of obtaining transportation and EoL information is also explained in Sects. 14.3.4.3 and 14.3.4.4, background data such as process inventory data was selected in Ecoinvent database.

## **14.4 Results and Interpretation**

100 items per each of the tree variants (F1, F2 and F3) are assessed using ReCiPe Endpoint H method to compare their environmental performances. The results of three individual impact categories as well the total impacts are shown in Table 14.3 and Fig. 14.5. As shown, F2 presents the highest environmental impacts of the three variants (1941.98 points), F3 has the second highest impacts (1882.93 points), F1 has the lowest impacts (466.67 points), which is 76% less than F2 and 75% less than F3.

The key life cycle stage and “hotpot” process are identified, as shown in Fig. 14.6. Undoubtedly, production stage has the highest impact, which is the key life cycle stage to the total impact contribution of all three products, it is because the production stage is input-output intensive stage where the majority consumption of materials and energy have taken place.

For F1, the production of glass fiber reinforced panel presents to have the highest environmental impact which accounts for 74.2% of F1's total impact. The environmental impact mainly allocated in Glass Fiber Production (36.4%); The transportation phase contributes 15.17% negative impacts of the total impacts due to the long transportation distance and fossil fuel consumption, and 10.25% of negative impact is contributed by the packaging stage. On the contrary, the result presents that EoL

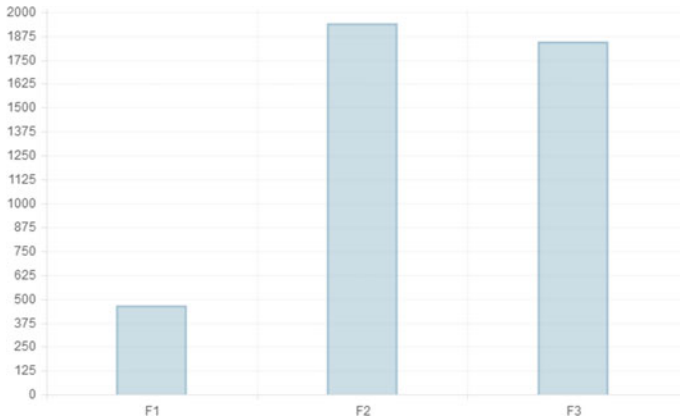

**Table 14.2** Bill of materials (F1, F2, F3)

F1		F2		F3	
Inputs		Inputs		Inputs	
<i>Materials</i>		<i>Materials</i>		<i>Materials</i>	
Polyurethane	2.16 kg	Steel (Pressed Steel Sheet)	3.49 kg	High density fiberboard	9.85 kg
Glass fiber	8.66 kg	Steel (stringer)	12.3 kg	Steel sheet	1.51 kg
		Cement	8.52 kg	Steel (stringer)	12.3 kg
Acetone	1.20L	PVC	0.66 kg	PVC	0.05 kg
Resin	0.50L	Adhesive	0.04 kg	Adhesive	0.002 kg
Carbon steel	5.20 kg	Medium density particleboard	6.77 kg	Rubber	0.79 kg
Plastic	0.07 kg	Plastic	0.11 kg	Plastic	0.01 kg
Paperboard	1.10 kg	<i>Transport</i>		Wood	0.03 M <sup>3</sup>
<i>Energy</i>		Freight road transportation	3541 km	Paperboard	0.87 kg
Electricity	0.48kw/h	Freight railway transportation	12451 km	<i>Transport</i>	
<i>Transport</i>				Freight road transportation	3541 km
Road transport (Material Deliver)	2517 km			Freight railway transportation	12451 km
Railway (Product Transport)	11477 km				
Output		Output		Output	
<i>Product</i>		<i>Product</i>		<i>Product</i>	
Floor panel	8.34 kg	Sandwich steel panel (Cement Injected)	12.60 kg	Wood based raised floor panel	12.20 kg
Stringer	3.42 kg	Stringer	12.3 kg	Stringer	12.3 kg
<i>Waste</i>		End-of-life treatment		End-of-life treatment	
Solid waste	1.71 kg	Landfill	12.60 kg	Incineration	12.20 kg
End-of-life treatment					
Recycle (Composite Material)	7.82 kg				
Reuse (Carbon Steel)	4.00 kg				
Landfill	4.27 kg				

**Table 14.3** Environmental impacts in endpoint category

Impact category	F1	F2	F3	Unit
Ecosystem quality	109.62	498.59	573.16	Points
Human health	149.95	669.59	588.55	Points
Resources	207.1	773.8	721.22	Points
Total	466.67	1941.98	1882.93	Points



**Fig. 14.5** Bar chart of total environmental impact results

phase produce about-9.65 points impacts, this result indicates that the waste scenario (discussed in the System Boundary section above) may produce a positive environmental performance which reduces the total impact by 2.07%.

Similarly, the production is the Key life cycle phase of F2. The production of stringer is the highest environmental impact process of F2 which contributes 45.66% of the total impact. The second highest impact phase is the packaging (29.64%), and the reason behind this is, according to the producer, each panel is going to be packaged with wooden (particleboard) materials to ensure product safety during transportation. Nevertheless, the material usage and mass related factors increased the impacts of different categories, and consequently increased the total impact. The transportation phase of F2 produced 12.62% of its total impact.

For F3, the production of stringer also is the hotspot process (48%), followed by the fiberboard production (37%). The transportation contributes 9.15% of F3’s total impacts.

Figure 14.7 illustrates the relative impacts in percentage of F1, F2, F3. From an endpoint impact category perspective, F1 presents the smallest percentage (about 25%) of impact on Ecosystem Quality whilst F2 is about 90%, F3 is almost 100%. This is because: the panel of F1 is fully made of composite material which relatively less water involved in production processes thus effects less in ecosystems; in contrast, the wood-based materials, which are majorly used in F2 (packaging material)

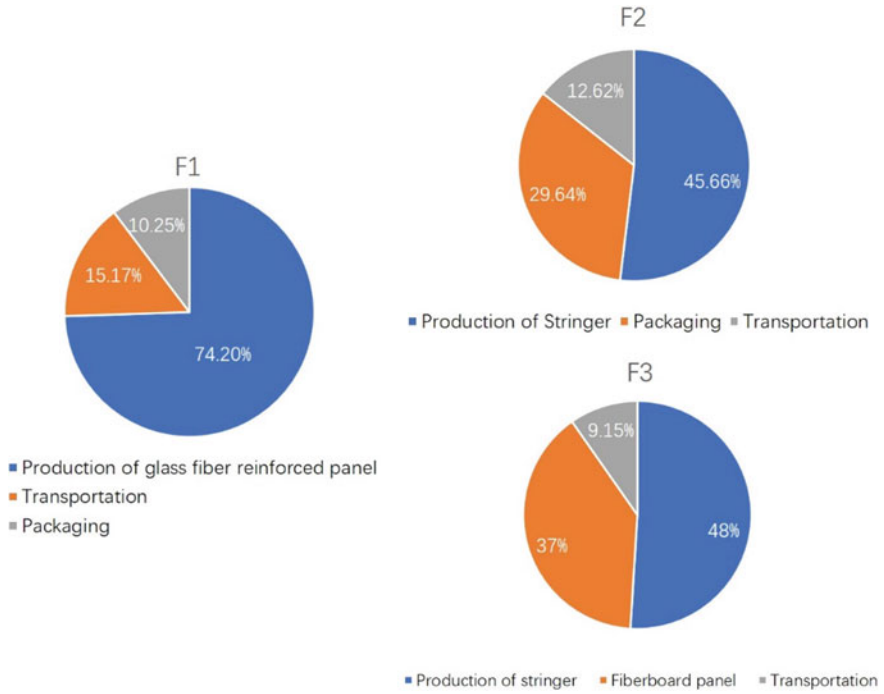

**Fig. 14.6** Key environmental process of F1, F2, F3

**Relative Results**

The following chart shows the relative indicator results of the respective project variants. For each indicator, the maximum result is set to 100% and the results of the other variants are displayed in relation to this result.

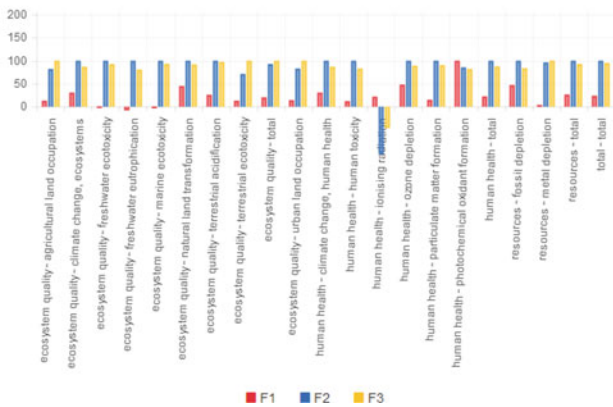

**Fig. 14.7** Relative impacts of three flooring products

and F3 (panel material), are naturally grown material which affects greatly on this category. It could result in a large amount of potential impact on ecosystem quality such as on Climate change and Terrestrial acidification. In Human Health category, the impact is mainly affected by the complexity of materials used in products or product systems, particularly by chemicals used and the amount of materials used. Again, F2 scores the highest amongst the three flooring products (100%) followed by F3 (90%), and F1 still has the lowest score (about 30%) in this endpoint category. In category of Resource, F2 has the highest impact as well because of the Production of stringer and Packaging phases. F3 presents a little bit less impact than F2 which is 90%. F1 has the lowest percentage (30%) of impact on this category.

## 14.5 Discussion

### 14.5.1 *Barriers of Applying Eco-Features to LCA Study*

Assumptions have been made in the LCA study. To reduce uncertainty of the study, flooring products under study were assumed to have a same lifespan for all the three flooring products investigated (raised flooring products are required to have a 25-year lifespan according to British raised floor standard). However, in real situations, the service life (i.e. the duration of product in use) of a flooring product is influenced by various kinds of factors. Product durability is a direct factor influences the lifespan. Taking the floor covering as an example, compared to F1 which does not have extra floor covering, the adhesive attached PVC floor covering used in F2 and F3 are more likely suffering from floor surface damage, which can ascribe to surface colour faded, edge curls or even torn. Thus, F1 should have a longer serve time than the other two flooring products. Besides, wood-based material used in F3 is easily affected by humidity and temperature, especially with ventilation system underneath. Humidity and temperature frequently change may leads to panel distortion. Consequently, the product ought to have a shorter serve life than the other counterparts. Another reason leads to a shorter lifetime of flooring product would be customer preference for change.

LCA is a quantitative method emphasizing on evaluating the countable process data. Some qualitative eco-features are unable to convert to countable value, and, consequently, cannot be assessed in a LCA process. F1 embraces other eco-features such as easy to transport, easy to handle and adjustment, easy to disassemble, reduction of deliver space and packaging material. These eco-features have enhanced the eco performance of proposed product in a great scale, also have meaningful act on saving energy or provide a user-friendly usability in applications, however, they are unable to taken into account in the LCA method.

### ***14.5.2 Environmental Performance Improvement Opportunities***

Though the flooring products under study are made from various of materials which require different manufacturing processes, thus cause impacts on environmental differently. There are still opportunities in improving their environmental performance. For example, for F2, reducing or changing the packaging material will have a great improvement on total environment impact. As explained above, the inappropriate using of packaging material contributes massive negative impact to F2's total impact. Changing the packaging material or reducing the material usage will have a great improvement on F2's environmental performance. For instance, if using the packaging material in accordance with F3, the total impact of F2 could be reduced by 45%. For F3, the improvement opportunity is on reducing the thickness of panel or the weight of stringer. Wood-based material is an impact-intensive material as mentioned, so reducing this kind of material usage by thicken the floor panel will have a large improvement of the total impact. The reduction of material usage is an effective alternative only in condition of meeting related quality standard.

## **14.6 Conclusion**

A recently developed raised flooring product (F1) was introduced and compared with two existing raised flooring products(F2, F3)by utilizing the LCA technique. LCA software openLCA was employed in line with Ecoinvent. The analyses are conducted using ReCiPe Endpoint H method. The analysis result reveals that the proposed floor (F1) has the lowest environmental impact (466.67) in comparison with F2 and F3 (1941.99 and 1846.94 respectively). The total impact of F1 is 76% and 75% less than F3 and F2 respectively.

The key environmental impact life cycle stage and processes of three products have been identified. The production is the key environmental impact stage of all three products throughout their life cycle. The production of glass fiber is the key environmental process in F1, which contributed 36.4% followed by transportation stage (15.17%) and packaging (10.25%). The production of stringer presents the biggest environmental issue process in F2 (45.66%), while packaging is the other hotspot stage in F2 (29.64%) due to the material used. For F3, production of stringer accounts for 48% of the total impact which is the hotspot process. The other key environmental process issue is the production of fiberboard which contributes 37% of F3's total impact.

Opportunities in improving environmental performance of F2 and F3 are proposed according to the LCA results. For F2, reducing or changing the packaging material will have a great improvement on total environment impact. The improvement opportunity for F3 is to reduce the thickness of panel or the weight of stringer.

However, the reduction of material usage is an effective improvement alternative only in condition of meeting related quality standards.

There are limitations of the new raised flooring product and the comparative LCA study. Although the composite raised floor embraces several prominent features, the price of the product is relatively higher than the other flooring products under study, which is a disadvantage when launching it to market. In addition, assumptions have been made in the LCA study including the lifespan of three products, packaging method of F1 and transportation method of three products. Some qualitative eco-features are also unable to be considered in the LCA.

It can be concluded that, with the consideration of environmental issues in early stage of product development, the proposed raised floor product (F1) embraces several eco features which have proven to have superior environmental performance. The study gives example of LCA comparison of raised flooring products with step-by-step explanation and in-depth analysis. The proposed raised flooring product can be considered as benchmark in eco flooring innovation. The LCIA results are useful in better understanding environmental impact allocation through raised flooring's lifecycle.

**Acknowledgements** The authors acknowledge the research grant received from the Ministry of Science and Technology, China (Grant No. 2015DFA51330), which supported the research presented in this paper.

## References

- Baumann, H., & Tillman, A.-M. (2004). *The Hitch Hiker's Guide to LCA: An orientation in life cycle assessment methodology and application*. Lund: Studentlitteratur.
- BSI. (2001). BS EN 12825:2001 Raised Access Floor. In BSI.
- Ecoinvent. (n.d.) ecoEditor for ecoinvent version 3 ecoinvent, ed. *ecoinvent*. Retrieved March 12, 2017, from <http://www.ecoinvent.org/data-provider/data-provider-toolkit/ecospold2/ecospold2.html>.
- Ecoinvent. (n.d.) The ecoinvent Database. Retrieved October 10, 2018, from <https://www.ecoinvent.org/database/database.html>.
- Eisfeldt, F. (2017). PSILCA results: A comparison of PSILCA SimaPro and Starter openLCA. Retrieved May 15, from <http://www.openlca.org/learning/>.
- Geng, A., Zhang, H., & Yang, H. (2017). Greenhouse gas reduction and cost efficiency of using wood flooring as an alternative to ceramic tile: A case study in China. *Journal of Cleaner Production*, 166, 438–448. <https://doi.org/10.1016/j.jclepro.2017.08.058>.
- GreenDelta. (n.d) openLCA. Retrieved October 5, 2018, from <http://www.openlca.org>.
- ISO (International Standardisation Organisation). (2006a). ISO 14040:2006-Environmental management: Life cycle assessment: Principles and framework. Retrieved March 3, 2018, from <https://www.iso.org/standard/37456.html?browse=tc>.
- ISO (International Standardisation Organisation). (2006b). ISO 14044:2006-Environmental management: Life cycle assessment: Requirements and guidelines. Retrieved March 3, 2018, from <https://www.iso.org/standard/38498.html?browse=tc>.
- Jönsson, Å. (1999). Including the use phase in LCA of floor coverings. *The International Journal of Life Cycle Assessment*, 4(6), 321–328.

- Jönsson, Å., Tillman, A.-M., & Svensson, T. (1997). Life cycle assessment of flooring materials: case study. *Building and Environment*, 32(3), 245–255.
- Marvin, S. K., Jack, C. G., & Jack, M. R. (1984). Access flooring panel. US Patent 19830519468, filed August 4.
- MOB. (1992). PSA MOB PF2 PS: Platform Floors (Raised Access Floors) In PSA Specialist Services.
- NETFLOORUSA. (2015). Basics of raised access floors. Retrieved November 28, 2015, from <https://www.netfloorusa.com/basics-raised-access-floors>.
- Nicoletti, G. M., Notarnicola, B., & Tassielli, G. (2002). Comparative Life Cycle Assessment of flooring materials: ceramic versus marble tiles. *Journal of Cleaner Production*, 10(3), 283–296.
- Potting, B. (1995). Life-cycle assessment of four types of floor covering. *Journal of Cleaner Production*, 3(4), 201–213.
- PRè. (2013). ReCiPe Report. In Online Report.
- Project Agreement. (2015). Agreement on conducting the joint research and development of new environmental protection flooring products made from composite materials, the sustainable flooring products project consortium.
- Reynolds, P., Pavic, A., & Waldron, P. (1998). *Modal testing of a 150-tonne concrete slab incorporating a false floor system*. Paper presented at the Proceedings of the International Modal Analysis Conference-IMAC.
- Reza, B., Sadiq, R., & Hewage, K. (2011). Sustainability assessment of flooring systems in the city of Tehran: An AHP-based life cycle analysis. *Construction and Building Materials*, 25(4), 2053–2066. <https://doi.org/10.1016/j.conbuildmat.2010.11.041>.
- Sangwan, K. S., Choudhary, K., & Batra, C. (2017). Environmental impact assessment of a ceramic tile supply chain—a case study. *International Journal of Sustainable Engineering*, 1–6. <https://doi.org/10.1080/19397038.2017.1394398>.
- Srinarayana, N., Fakhim, B., Behnia, M., & Armfield, S. W. (2012). *A comparative study of raised-floor and hard-floor configurations in an air-cooled data centre*. Paper presented at the InterSociety Conference on Thermal and Thermomechanical Phenomena in Electronic Systems, IThERM.
- Strathclyde, University of. (2017). Recycled glass fibre for cost-effective composites. Retrieved April 21, from <https://www.strath.ac.uk/rkes/fly/recycledglassfibreforcst-effectivecomposites/>.
- Tate. (2013). Access floor solutions—Product Guide. Retrieved December 20, 2017, from <https://www.tateinc.com/sites/default/files/support-docs/tate-productguide.pdf>.
- Yang, Y., Boom, R., Irion, B., van Heerden, D.-J., Kuiper, P., & de Wit, H. (2012). Recycling of composite materials. *Chemical Engineering and Processing: Process Intensification*, 51 (Supplement C), 53–68. <https://doi.org/10.1016/j.cep.2011.09.007>.

**Part IV**  
**Case Studies of Integrated Approach  
for Sustainable Product Development**



# Chapter 15

## Integrated Approach for Eco-Lighting Product Development



Jose L. Casamayor and Daizhong Su

**Abstract** Lighting products are essential in our lives, but they also produce a high environmental impact in our planet. One of the most effective and feasible approaches to reduce their environmental impact is eco-design. However, there are not comprehensive and updated systematic methods to eco-design lighting products. This chapter presents an effective comprehensive eco-design integrated approach to design lighting products. The approach integrates eco-design guidelines, life cycle assessment, finite element analysis, lighting driver selector and experimental methods into the product development process. The approach is demonstrated with a case study based on the design of a luminaire with low environmental impact produced by a lighting manufacturer. The advantages and disadvantages of the methods/tools involved in the approach are discussed. This approach contributes to the body of knowledge in the area of methods and tools to support designers to design lighting products with lower environmental impact.

**Keywords** Lighting · Luminaire · Sustainability · Sustainable product design · Eco-design · Life cycle assessment

### 15.1 Introduction

In 2010, the total market revenue of general lighting worldwide was around 52 billion euros, and by 2020, the world market is projected to reach 88 billion Euros (McKinsey & Company 2012). This clearly indicates the high demand of this category of products, which are essential in our daily lives. However, lighting products also cause a high negative impact on the environment. The impact is caused in each of the lighting products' life cycle stages (i.e. manufacturing, transport, use, end of

---

J. L. Casamayor (✉)  
Coventry University, Coventry, UK  
e-mail: [ac8335@coventry.ac.uk](mailto:ac8335@coventry.ac.uk)

D. Su  
Advanced Design and Manufacturing Engineering Centre, Nottingham Trent University,  
Nottingham, UK  
e-mail: [daizhong.su@ntu.ac.uk](mailto:daizhong.su@ntu.ac.uk)

life), and, particularly, during their use stage, where lighting accounts for 19% of electricity consumption worldwide and 50% of electricity consumption of European cities (CELMA 2011).

The environmental impact of lighting products can be reduced or eliminated through different approaches that can be included within two general strategies: Sustainable production and sustainable consumption. Sustainable consumption approaches can be difficult to implement successfully because consumers' behaviour is usually out of the control of manufacturers and product developers. In contrast, sustainable production approaches are less difficult to implement successfully than consumption, because the manufacturer (and product developer) usually has total control about how the lighting product will be designed, manufactured, packaged, transported, and, to some extent, used and disposed.

Within the sustainable production category there are two approaches to decrease the environmental impact of lighting products: (1) to reduce the environmental impact of lighting products when these have already been designed and manufactured, also called 'end of pipe' solutions, (2) to diminish the environmental impact of lighting products at the design stage.

The reduction of environmental impact using the first approach is limited, because it is difficult to reduce the effect on the environment of a lighting product that has already been defined (i.e. there is no possibility to change the structure and materials used in the product), so the only possible strategies to reduce the impact when the product has been already designed and manufactured is to decrease the environmental impact of the industrial processes used during the product life cycle (e.g. manufacturing, distribution), usually through optimisation of processes.

Using the second approach can produce higher reduction of the environmental impact, because it is at the design stage when the complete architecture and life cycle of the lighting product have to be decided (designed), and these design decisions will be reflected in the environmental impact of the lighting product. Once the lighting product has been defined, implementing strategies to reduce the environmental impact are usually costly and reduction effects on the environment are minimal (Lewis et al. 2001) as shown in Fig. 15.1. It has been stated that 80% of the product's total environmental impact is determined at the design stage (Charter and Tischner 2001; Mcalone and Bey 2009), so special attention should be paid at the design stage of lighting products to reduce their negative impact in the environment.

This chapter focuses on the study of the reduction of the environmental impact of lighting products from a sustainable production perspective, by adopting an eco-design approach.

## 15.2 Literature Review

In eco-design methods, environmental considerations are taken into account during the design process. This means that product developers must also be able to assess the environmental impact of concepts/design features during the design process, in

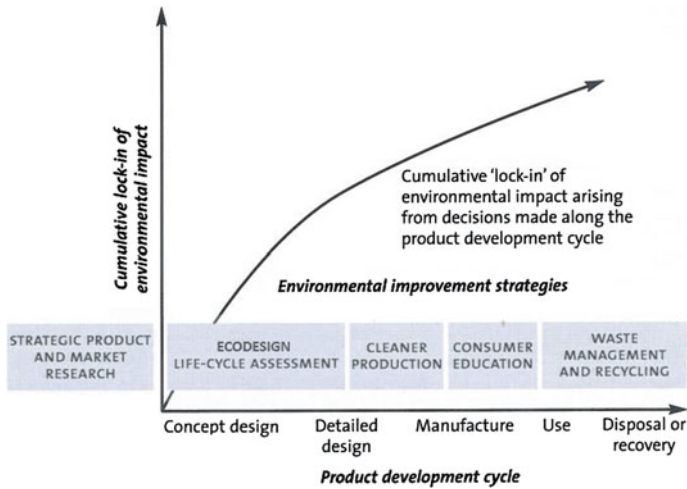

**Fig. 15.1** Conceptual representation of environmental impact over a product life cycle

addition to other parameters. That is why an additional set of eco-design tools (not used in traditional design processes) that can assess, and help/guide to reduce the environmental impact of the product have to be included in the eco-design process.

Considerable attention has been paid to eco-design, and a substantial amount of literature has been published in relation to (1) the consideration of environmental aspects in products (McDonough and Braungart 2002; Shedroff 2009; Hinte 2004; Wimmer et al. 2010; Walker 2006; Papanek 1998; Graedel and Allenby 1996; Giudice et al. 2006; Billatos and Basaly 1997; Wenzel et al. 1997); and (2) the consideration of the environmental impact of products during the design process (Fiksel 2009; Bhamra and Lofthouse 2007; Vezzoli and Manzini 2008; Rodrigo and Castells 2002; Niemann 2009; Kärnä 2002; Bergendahl 1995; Tingstrom et al. 2006; Tischner et al. 2000; Brezet and Van Hemel 1997; Dewulf 2003; Jansen and Stevels 1998; Wimmer et al. 2004; ISO 2002; UNEP and TU Delft 2006; Lewis et al. 2001; Stevels 2007; Mcaloon and Bey 2009; Ulrich and Eppinger 2008; Knight and Jenkins 2009; Vinodh and Rathod 2010; Platcheck et al. 2008).

Some of the studies (Hanssen 1999; Byggeth et al. 2007; Waage 2007; Charnley et al. 2011; Maxwell and Van der Vorst 2003; Garetti et al. 2012; Maxwell et al. 2006; Ge and Wang 2007) present general approaches or frameworks (not step-by-step detailed methods) for corporations, to produce more sustainable products. Other studies have focused on specific stages and/or processes (not the complete design process) of the eco-design process (Pigozzo et al. 2010; Gehin et al. 2008; Vinodh and Jayakrishna 2011; Kengpol and Boonkanit 2011; Van der Zwan and Bhamra 2003). Only a few studies (Tischner et al. 2000; Wimmer et al. 2010; Dewulf 2003; Mcaloon and Bey 2009; Brezet and Van Hemel 1997; Nielsen and Wenzel 2002) provided a full step-by-step prescriptive design process model to reduce the environmental impact of

products. However these were focused on generic products (not lighting products), and have not been updated with the latest knowledge about the latest eco-design tools.

One of the key problems of existing eco-design approaches, tools and methods, utilised to eco-design generic products, is that they are not applied by product developers and/or implemented successfully by companies. For this reason, other studies have looked at why these eco-design approaches, methods and tools are not implemented (Deutz et al. 2013; Petala et al. 2010; Boks 2006; Spangerberg et al. 2010), and how these could be improved to have a better acceptance by users (Tingstrom and Karlsson 2006; Kaebernick and Sun 2003; Byggeth and Hochschorner 2006; Lofthouse 2006; Lindahl 2005, 2006; Le Pochat et al. 2007), to ensure a wider implementation.

The majority of the methods have been developed to eco-design generic products, only a few studies have been focused on providing eco-design guidelines to develop specific categories of products such as electric-electronic products (Rodrigo and Castells 2002; Kärnä 2002). There are few comprehensive and up to date studies focused on the design of eco-lighting products. The only study (Schmalz and Boks 2010) related to design of eco-lighting products is focused on how to reduce the environmental impact of lighting products by changing the user behaviour only, so it does not adopt a comprehensive approach, which considers all the other product life cycle stages (e.g. manufacturing, end of life).

Casamayor and Su have studied the area of eco-design of lighting products (2010a, b, 2011a, b, 2013). However, these studies present early incomplete findings about specific issues about the eco-design process of lighting products, so a full comprehensive and systematic eco-design approach is needed.

It is probable that some companies are using proprietary eco-design approaches, methods and/or tools to eco-design lighting products, but these have not been disclosed to the general public outside the companies, so they are not available to use or review.

This chapter aims to contribute to the body of knowledge in this area with the development, demonstration and discussion of a comprehensive and updated integrated approach to effectively eco-design lighting products, in a real world industrial context.

### 15.3 Eco-Design Approach

The eco-design approach begins with Product Design Specifications (PDS), which are materialised into a finished product at the end of the process.

The approach (Fig. 15.2) shows the methods and tools applied at each stage of the design process. In each of these design stages, different tools and methods are applied in order to support the product designers' decision-making. During the design process, the product is subject to a continuous synthesis and analysis iteration,

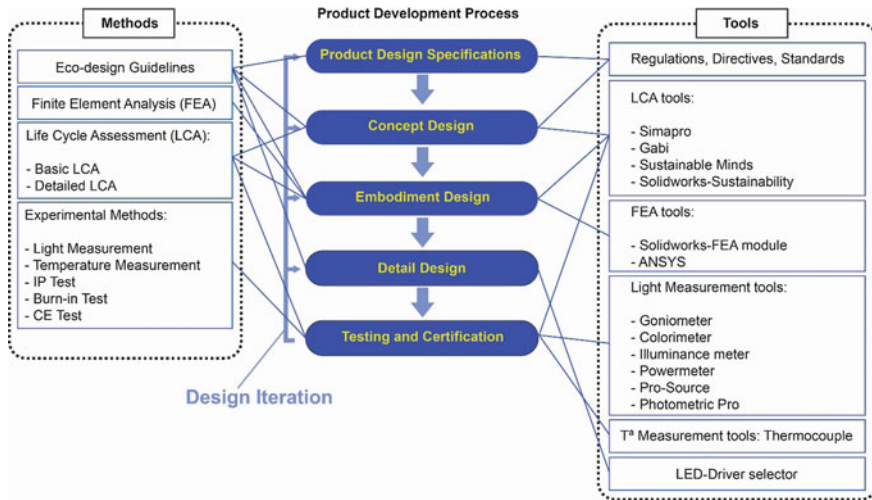

Fig. 15.2 Integrated approach to eco-design lighting products

until the product is totally defined. In eco-design processes, the assessment of the environmental impact of design decisions has to be carried out, that is why eco-design tools and methods need to be applied during the process.

### 15.3.1 Eco-Design Guidelines (EDG)

Eco-design guidelines are used in eco-design processes to provide best practice generic rules that can be applied at each product life cycle to reduce the environmental impact of the product. Some of these are generic, and some product-specific. In this research, the ones that apply to lighting products have been considered. Eco-design guidelines can be used when there is no reference product at the beginning of the design process, or when specific eco-design features have to be included in the design brief and/or Product Design Specifications (PDS).

Eco-design guidelines can be ‘converted’ into checklists so they can be used during the design process to check if the eco-design guidelines stated in the Product Design Specifications (PDS) are achieved during the design process. There are many handbooks and manuals that provide eco-design guidelines and checklists to reduce the environmental impact of products.

EDG can be informed from best eco-design practice and from the application of environmental regulations and directives such as RoHS (European Commission 2011) and WEEE (European Commission 2012). They can provide best generic rules that can be applied at each product life cycle to reduce the environmental impact of the product (e.g. using fewer or recyclable materials), or be informed by regulations

and directives such as WEEE or RoHS, to ensure that the product can comply with those regulations and directives.

In the concept design stage, the EDGs are applied in the generation of design concepts, and the EDGs are used as checklists in each design iteration. In the embodiment design and detail design stages, the EDGs are still followed as checklists to guide each design iteration. They are, therefore, applied during the generation and refinement of design concepts, as checklists, in each design iteration to guide design decisions. An example of the EDG is given in Sect. 15.4.1.

### 15.3.2 *Life Cycle Assessment (LCA)*

LCA is a methodology used to assess the environmental impact of products, processes or services. Today, standardisation of LCA methodology has strengthened its status as perhaps the most important method for assessing a project's overall environmental impact (Malmqvist 2004). LCA, adopts a life cycle approach, and involves the evaluation of all aspects of a product system through all the stages of its life cycle. A typical LCA consists of the following main stages: (1) Goal and scope definition, (2) Life Cycle Inventory (LCI) analysis, (3) Life Cycle Impact Assessment (LCIA) and (4) Life Cycle Interpretation (Lewis et al. 2001; Jensen et al. 1997).

The LCA methodology is usually embedded in software applications called LCA-based software tools. There are different types of LCA-based software tools that can be used for different purposes. Some have been developed to conduct simple LCA and others to conduct detailed LCA. In the approach demonstrated, Sustainable Minds (2018) was used to conduct simple LCA and Simapro (PRé 2018) was used to conduct detailed LCA. These tools usually contain databases with internal data of the company, as well as secondary data to account for background data. Some of these software applications (i.e. Sustainable Minds) have been simplified to suit non-LCA experts needs, like product developers, and others present more complex and advanced interfaces and features allowing more complex assessment (i.e. detailed LCA) usually required by LCA experts.

In the concept design stage, Life Cycle Assessment (LCA) software tools are used to assess product's concepts sustainability. Because at the concept design stage, the product has not been fully defined, and lacks more detailed information which will be confirmed in the detail design stage, only basic LCA can be conducted. Less expensive, less time consuming and easier to use LCA software tools, such as Sustainable Minds, are enough to conduct basic LCA of the product concepts. Because more detailed product information is available at the embodiment design stage, Simapro, which enables to conduct a detailed LCA can be applied. Detailed LCA of the product can also be conducted, with LCA tools such as Simapro, at the end of the detail design stage when they product is fully defined. The results of the final LCA can be utilised to compare the product's environmental impact with other

products, or with the initial concept to compare eco-design improvements. It can also be used to inform eco-labels, where detailed LCA results are required.

### ***15.3.3 Finite Element Analysis (FEA)***

FEA is used to virtually simulate the functioning of the lighting product under specific operating conditions in a computer. FEA tools can model the behaviour of lighting products in specific conditions, to simulate how they would behave in real-world or extreme operating conditions. The application of these tools (e.g. Solidworks and ANSYS) can help to reduce the material used in the lighting product or increase its reliability. The results of these tools usually complement the results of thermal measurement experiments, to validate the results obtained in the simulation.

The FEA tool used in the eco-design approach demonstrated in this research is the CAD tool Solidworks (Dassault Systems 2018) with an integrated FEA module. In the embodiment design stage, once the lighting product is virtually modelled in 3D with Solidworks CAD software, FEA methods are applied through the FEA module in Solidworks to conduct simulations to predict the thermal behaviour of the heat sinks in the expected operating environment. This is necessary to know if the heat sink is over dimensioned for the required thermal diffusion function. For example, if the heat sink is over dimensioned, then we will be using more material than required, so the heat sink should be re-designed or replaced by one with less volume (i.e. more material-efficient). Solidworks was used at this stage to understand and predict the thermal behaviour of the initial heat sink and the final heat sink, to confirm that the final selected heat sink was more thermal-efficient, and hence material efficient, than the initial heat sink selected.

### ***15.3.4 LED-Driver Selector***

This tool is used to optimise the match between an LED and its driver, to reduce the power consumption of the LED-driver system to save energy. The LED-driver selector (Future Lighting Solutions Inc. 2018) is utilised during the detail design stage and consists of using a web-based application where the LED specifications can be inputted, so the application can show the specifications of the optimum driver needed for a specific LED.

### **15.3.5 Experimental Methods**

#### **15.3.5.1 Light Measurement**

Light measurement is utilised to measure the light performance of the lighting product. It allows to measure the quantity and quality of the light produced, as well as the power consumption of the lighting product. This information is required to conduct detailed LCA, particularly when the LCA is used to compare and assess the environmental impact of two lighting products. This information is also required to obtain the technical specifications (i.e. light performance) of the lighting product for consumer information purposes.

Several, hardware and software-based, tools are used to conduct the light measurements in the eco-design approach: Goniometer (Radiant Vision Systems 2018a), illuminance meter (Konica Minolta 2018a), Colorimeter (Konica Minolta 2018b), Power meter (Maplin 2018) and two software-based tools: ProSource (Radiant Vision Systems 2018b) and Photometrics Pro (J. Solutions Inc. 2003).

The Goniometer is used to measure the light distribution and luminous flux of the lighting product. ProSource and Photometrics Pro software are used to process, analyse and communicate with graphs (i.e. polar diagrams) the results of the light-related data captured by the goniometer. The illuminance meter is used to measure the illuminance, and the colorimeter to measure the Colour Correlated Temperature (CCT) of the lighting product. The power meter is used to measure the power consumption. Standards such as IES-LM-79-08 (IES 2008a) are followed to conduct the light measurements.

All these parameter measurements must be conducted with a physical full-scale and fully functional prototype of the lighting product, as this is necessary to carry out the measurements.

#### **15.3.5.2 Other Experimental Methods**

Other experimental methods are applied with the support of specific tools to: (1) measure the internal temperature of the lighting product (temperature measurement experiment), (2) test its reliability (burn-in test), (3) test its water/dust ingress protection (IP test), and (4) to ensure the product can pass the CE safety regulations to obtain the CE mark (CE test).

The temperature measurement experiment consists of measuring the temperature inside the casings of the lighting product prototype with a thermocouple (Maplin 2018), to understand the internal thermal behaviour of the lighting product, and re-design the product if the temperature is too high, to avoid premature failure of components due to high temperatures in the final lighting product manufactured.

The burn-in test consists of switching on the lighting product for 2,000 h. non-stop to confirm it works with the expected performance during 2,000 h. The aim of the burn-in test is to detect faulty components and systems which could lead to: (1)



premature failure of the lighting product, or (2) premature degradation of components leading to lower performance of the lighting product.

The IP test consists of assessing the protection of the lighting product against ingress of solid bodies and/or liquids in a test chamber, varying over differing degrees of protection, depending upon the IP value (e.g. IP 45) requirements. After the test, the effects inside the lighting product are measured to give the product an appropriate IP rating.

All these methods are applied at the final stage (i.e. testing and certification) of the design process when the lighting product is a finished prototype. The order of conducting these experiments is: (1) temperature measurement experiment, (2) IP test, (3) Burn-in test, and (4) CE test.

These methods are conducted to ensure the reliability and durability of the lighting product, which can ultimately reduce the environmental impact of the lighting product as they increase the useful life of the product.

## **15.4 Application of the Approach to Develop an Eco-Lighting Product**

The method has been applied in the development of an LED lighting product, which has been manufactured by Ona Product S.L. a lighting product manufacturer. The product is currently available on the market as the company's product (<http://www.recycleled.eu/es/>). This section demonstrates how the eco-design approach presented in Sect. 15.3 can be applied in the development of a real commercial product, as a case study. The section has been divided in five sub-sections based on the main stages of the design and development process followed: Product Design Specifications (Sect. 15.4.1), concept design (Sect. 15.4.2), embodiment design (Sect. 15.4.3), detail design (Sect. 15.4.4) and testing and certification (Sect. 15.4.5).

### ***15.4.1 Product Design Specifications***

The first step of the method is to define the Product Design Specifications (PDS).

The PDS will guide and delimitate (i.e. constrain) the boundaries of the output (i.e. solutions) created by the product designer.

The company specified the following PDS of the lighting product:

- Modular structure, so it can be customised according to customer needs.
- Aimed at contract and domestic markets.
- Indoors use, including toilets (IP44).
- Easy light control to provide the exact amount of light where needed, to avoid wasting light and energy.
- Aesthetically coherent/neutral.

- Use energy-efficient light sources (e.g. LED).
- For different lighting applications: table lamp/ceiling lamp (initially).
- Allow the possibility to incorporate different types of drivers for different markets.
- Have low environmental impact.

The eco-design specifications have to be informed from several sources including *Directives and regulations* that affect lighting products, and *eco-design guidelines*.

### **Directives and Regulations**

Regulations and Directives related with the environment that affect lighting products were reviewed and eco-design recommendations extracted from these to inform the PDS. These need to be complied to, not only to reduce the environmental impact of the lighting product, but also to avoid to breach the law. The most relevant are the following: Energy-related Products (ErP) Directive 2009/125/EC (European Commission 2009): This directive, among other points, bans the commercialisation of inefficient light sources. The general design recommendations that can be extracted out of this directive are the use of energy-efficient light sources, and to avoid the use of inefficient light sources such as incandescent light sources.

*Waste Electrical and Electronic Equipment recycling (WEEE) directive (European Commission 2012):*

This directive obliges manufacturers of electrical-electronic products to recover and re-use or recycle these at the end of product life. The general design recommendations for product designers that can be extracted from this directive are the use of recycled and recyclable materials; design the lighting product so it is easy to disassemble for repairing and recycling, and mark (identification codes) components and materials for easy identification (for recycling purpose) at the end of life. The design of systems around the lighting product to facilitate its re-use and recycling can also help to comply with this directive.

*Restriction of Hazardous Substances (RoHS) directive (European Commission 2011):*

This directive is concerned with the avoidance in products of specific harmful substances such as: lead, mercury, cadmium, hexavalent chromium and brominated flame-retardants (Polybrominated biphenyls and Polybrominated diphenyl ethers). The general design recommendations are to avoid these substances in lighting products, or to use them below the minimum thresholds agreed by the directive.

### **Eco-design Guidelines**

The eco-design specifications used in this case study have been informed by eco-design guidelines from the literature (Chitale and Gupta 2007; EcoSMEs 2010; Mcaloney and Bey 2009; Jedlicka 2009, 2010; Meinders 1997; Nordkil 1998; Sheddoff 2009; Siemens 2004; Tischner et al. 2000; UNEP and TU Delft 2006; Vezzoli and Manzini 2008; Yarwood and Eagan 1998).

The main eco-design guidelines considered and classified by their application per product life-cycle stage are the following:

***Manufacturing stage:***

- Material selection:
  - Use as small amount of material as possible.
  - Use recycled and recyclable materials.
  - Use one or few types of materials in the same product.
  - Avoid the use of banned toxic materials (As indicated in RoHS).
  - Select local materials.
  - Use materials which have established recycling networks.
  - When choosing recycled materials, select post-consumer recycled materials.
  - Avoid the use of adhesives or glues.
  - Use light materials (low density).
  - If using more than one material, they should be compatible for recycling.
  - Use materials that are durable.
  - Choose materials that achieve aesthetical properties over time (age gracefully)
  - Choose materials that do not require energy-intensive processes to be shaped.
  - Avoid composites and other thermostable plastics.
  - Avoid using scarce and limited materials.
  - Avoid use energy-intensive extraction and refinement materials.
- Choose manufacturing processes that:
  - Avoid energy-intensive manufacturing processes.
  - Do not waste material.
  - Recycle the material wasted (pre-consumer waste).
  - Do not create harming emissions.
  - Do not produce liquid and solid waste.
  - Use water and energy efficiently (if at all) and use renewable energies.
- Design components that are multifunctional.
- Specify re-manufactured components.
- Design components with minimum volume.

***Distribution stage:***

- Choose efficient transport means (e.g. ship).
- Avoid Air freight, because is very energy-intensive.
- Design efficient distribution/logistic systems.

***Use and maintenance stage:***

- Design modular products so that parts and components can be up-dated and repaired.
- Design easy to dismantle products to facilitate upgrade and repair of parts.
- Provide spare parts and components as well as a list with the product's components and the suppliers' references.
- Design products which are dirt-resistant, easy to clean and require little maintenance.

- Indicate on the product how it should be opened for cleaning or repair.
- Use light and motion sensors or timers and dimmers to reduce the amount of energy used.
- Use energy-efficient light sources and drivers.
- Locate components that might wear out easily in accessible areas.
- Design lighting products with devices that allow the control of the quantity and quality of light in order to use the exact quantity and quality needed for each purpose.
- Allow users to switch off lighting modules individually.

***End of life stage:***

- Fasteners/joints:
  - Use as few fasteners as possible. Use the same type of fastener if possible, in order to facilitate disassembly.
  - Use fasteners which do not require tools, or require standard tools.
  - Avoid welding joints; only join permanently materials that are compatible for recycling.
  - Use detachable joints such as snap-fit, screw or bayonet joints instead of welded, glued or soldered connections.
- Disassembly:
  - Design products so different parts (materials) can be separated easily and re-used, remanufactured or recycled depending on the component.
  - Reduce disassembly steps.
  - Use one disassembly direction to avoid reorientation.
  - Design for multiple detachments with one operation.
  - Design the product so it does not need to be dismantled for recycling.
  - Minimize the use of energy-intensive processes in disassembly.
  - The cost of disassembly has to be less than the cost of the material recycled.
  - Make sure that joining points are easily accessible and there is enough space to allow disassembly with tools.
  - Include symbols or pictograms to inform about the disassembly process.
  - Select joining systems that can be dismantled after long periods of use.
  - Avoid use of joints that require energy-dependent tools for disassembly.
- Recycling:
  - Avoid the use of coating on materials surfaces.
  - Avoid the use of labels, use emboss to mark components.
  - Use one single material for all the components if possible.
  - Minimise the number and length of wires.
  - Facilitate reuse and recycling by using standard codes for identification (marking) of materials and components.

## 15.4.2 Concept Design

After defining the PDS and the eco-design guidelines, the next step is to begin to define the concepts of the lighting product. This section describes the concept design stage of the eco-design approach.

### 15.4.2.1 The Initial Concept

The initial concept was informed by the PDS. The concept that matched a higher number of PDS criteria was selected and further developed with more detailed sketches (Fig. 15.3).

The main design features of the initial concept, shown in Fig. 15.3, are explained below:

- All electronic components were installed in one tray, which allowed the easy updating, alteration and repair, and, hence, extend the lifespan of the lighting product.



**Fig. 15.3** Initial concept of the lighting product

- The casing of all the lighting modules used the same matrix for extrusion, thus saving cost, material and energy.
- The housing was made of recycled aluminium, and contained LED modules, heat sinks and the energy-efficient electronic driver, which could be used with or without dimmer. Aluminium is easy to machine, and, hence, is less energy-consuming to process than other metals. It also has corrosion-proof properties for outdoors environments, durability, low weight, malleability and high conductivity to conduct heat outside LED compartments. It can be obtained from recycled sources and could be collected and recycled again at the end of life of the product. It does not require protection surface finish as it creates its own natural protection. In addition to the housing of the modules, aluminium was also used for the axis, holder and lateral covers, so the whole product could be made of one single material for easy recycling.
- The disassembly process was easy because it required basic tools only, and used few detachable joints to assembly the product.
- It did not contain any banned toxic material (as specified by RoHS).
- Cooling fins avoided overheat of LEDs and other electronic components, thus extending their lifespan.
- The housing dimensions had been designed to contain a wide range of drivers and LED types in order to allow customization and upgrading of components over time.

#### **15.4.2.2 LCA of Initial Concept**

Once the initial concept was roughly defined, different environmental impact assessments of the lighting product were conducted with alternative materials or manufacturing processes to know which were the life cycle stages and components with the highest impact. At this stage of the design process, the lighting product was not fully defined yet and a lot of information was not available, only a simple LCA of the lighting product could be conducted. Therefore, Sustainable Minds (2018) software was used, a LCA software tool to conduct simple (i.e. not detailed) assessments, which adopts Okala impact assessment methodology (Sustainable Minds 2018) and uses Ecoinvent database. This tool allows a quick and reasonably objective environmental impact assessment, which is translated in scores (Okala points) for easy comparison between product concepts/versions. The scores provide the environmental impact of the concept based on the following main indicators: energy and raw material consumption, ecological damage, resource depletion and human health damage. This tool has been designed to carry out ‘screening’ LCAs and, since it does not require too much input data for the assessment and uses surrogates and average data from generic processes, it is very suitable for the early stages of the eco-design process, when initial concepts and their design features have to be assessed and modified quickly in an iterative process. Although the results of the assessment using Sustainable Minds are more objective and accurate than using matrix-based environmental

impact assessment tools, the results are not very accurate or detailed, and should only be used to guide decision-making.

At this stage of the design process, it was necessary to know which was the best material choice to make the housing of the product, so the concept was assessed with Sustainable Minds using different materials: Aluminium, High Density PolyEthylene (HDPE) and PolyEthylene Terephthalate (PET), in order to compare the total environmental impact of the concept using these materials. These materials were selected because of their following features:

- Aluminium because is corrosion-proof (for outdoors), has high durability, low weight, malleability (low energy required for processing) and high conductivity (to conduct heat outside LED) properties.
- High Density PolyEthylene (HDPE) has light weight, and is corrosion-proof, malleable, and easy to extrude. However, they usually need coating to improve their UV properties, and lose their quality (down-cycling) each time they are recycled, unlike metals (steel and aluminium) which can be recycled indefinitely without losing their properties. Also the use of polymers is not usually considered an environmentally-friendly choice because plastics use non-renewable resources and usually do not biodegrade. In addition, some versatile and cost-effective thermoplastics such as PVC are toxic and its use is not recommended.
- PET has light weight, is corrosion-proof, malleable and easy to extrude like the HDPE. It also has very good optical (transparent material) properties, which is required in lighting applications.

In conducting the LCA the following were assumed:

- 50,000 h was considered as the LED average estimated lifespan. This estimation was based on the useful life of the LED provided in the LED supplier datasheets.
- The concept used 4 LEDs of 3 W.
- LEDs modules and LED drivers were not considered in the assessment, because the aim of this assessment was to compare the environmental impact of the manufacturing of the housing only.

The LCA results obtained using Sustainable Minds are shown in Table 15.1. The LCA results showed that when aluminium was used the product's environmental impact was higher than when it was used HDPE or PET, which had similar environmental impact. Although selecting 100% recycled (instead of virgin) aluminium reduced the total impact greatly, the impact of producing recycled aluminium was similar than the impact using recycled HDPE or PET. Thus, in comparison of the production of 100% recycled aluminium with 100% recycled HDPE, the impact of both was similar. However, the extrusion process of the aluminium was much more energy-intensive than the one used to extrude the HDPE (37.2 vs. 0.45), thus resulting in higher total impact when using aluminium (100 vs. 65 Okala mPts) (Table 15.1). When it was assumed in the LCA that both materials could not be collected and recycled at the EoL, or that they were obtained from virgin (not recycled) sources, then aluminium had even higher impact than HDPE or PET. In both cases the greatest impact stage was the use phase (which is normal in energy-using products) followed

**Table 15.1** LCA results of the initial concept

	Units	Recycled aluminium	Recycled HDPE
<b>Impact per functional unit</b>	Okala mPts	<b>100</b>	<b>65</b>
<i>Ecological damage</i>			
Acidification	Okala mPts	0.07	0.5
Ecotoxicity	Okala mPts	55.15	64.94
Global warming	Okala mPts	0.65	0.35
Ozone depletion	Okala mPts	0	0
Water eutrophication	Okala mPts	0.03	0.02
<i>Resource depletion</i>			
Fossil fuel	Okala mPts	0.1	0.02
<i>Human health damage</i>			
Human respiratory	Okala mPts	0.11	0.07
Human carcinogens	Okala mPts	21.23	21.96
Human toxicity	Okala mPts	22.63	12.06
Smog	Okala mPts	0.03	0.09

by manufacturing. The highest impact category was Ecological damage (ecotoxicity), being higher (64.94) for HDPE and PET than aluminium (55.15). The second and third highest impact categories were in human health damage (human carcinogens and human toxicity), being human carcinogens higher in HDPE or PET (21.96) than aluminium (21.23) and being human toxicity higher in aluminium (22.63) than HDPE or PET (12.06).

According to the above analysis based on the LCA results, it is concluded that the difference of impacts between materials is not dependent on the material used (when using recycled aluminium, HDPE or PET) but on the manufacturing (extrusion) process, being more energy-intensive in the case of using aluminium.

The LCA-based screening software tools provides useful information about which material or industrial process to use, and which life cycle stage has higher impact, it would not be possible with other eco-design tools such as guidelines or matrix-based tools, however, the information provided by this tool should be used as a guidance since it is not very accurate. This assessment could have also been conducted with more complex LCA-based software tools like Simapro, and probably results would have been more reliable and accurate, although Simapro requires more expertise and time to learn and conduct the assessment, whilst Sustainable Minds is a very intuitive and easy to use tool for product designers for quick and easy environmental impact assessment.

After the first screening-assessment of the initial concept using different materials, HDPE and PET were better than aluminium to make the housing because they had less environmental impact than aluminium overall. Therefore, Recycled PET was finally selected because although both HDPE and PET had the same environmental impact, recycled PET had better optical, thermal and UV properties than HDPE (Ashby



and Johnson 2010). PET also allowed the possibility to use the already established recycling network of PET bottles and other PET-based products, contributing to the recyclability of the PET after disposal of the lighting product by consumers. In addition, the company has good business relations and access to a local supplier of post-consumer recycled PET.

### 15.4.2.3 Final Concept Selection

The initial concept design (Fig. 15.3) was modified and improved according to the PDS and further investigation including the LCA presented in the section above. After improvements, the final concept (Fig. 15.4) was derived with the following features:

- **Housing:** It was made of 100% recycled PET with no coating. As shown in Fig. 15.4, the housing had two types of modules: one module (driver module) housing the electronic driver, and another module (lighting module) housing the LEDs and aluminium heat sinks.
- **Modular design:** It could adopt 1–4 lighting modules, depending on the customer needs.
- **LEDs:** One LED of 4 W was used in each lighting module. In the versions of two/three/four LED units, 2/3/4 LEDs of 4 W were used.
- **Tube:** It was made of 100% recycled PET with no coatings. It contained the cable and was used to fix the product to different supports (i.e. wall, ceiling).

**Fig. 15.4** Final concept selected



- Electronic driver: It was energy-efficient, complied with RoHS directive, and had an Ingress Protection Rate (IP64).
- Aluminium heat sinks: each LED chip was fixed in one heat sink, and the heat sink was then fixed into the lighting module. The function of the heat sinks was to diffuse the heat produced by the LED. These were made of 100% recycled aluminium.
- Other components: Fasteners (zinc-made screws), connectors (made of Polypropylene which complied with RoHS directive), and cables (Brand/model: PTFE 2501 × 1.00, made of PET and copper which complied with RoHS directive).

### 15.4.3 Embodiment Design

In the embodiment design stage, the final design concept derived in the previous concept design stage was further developed. The design was modelled using CAD tools and the prototype was physically made, as well as simulated and tested to define its architecture and performance in more detail.

Several iterations were performed during this stage, and several eco-design tools were utilised. In this section the main iterations are explained with an emphasis on the relationship between the design features, design decisions, and their effect in the environmental impact of the lighting product.

#### 15.4.3.1 3D Virtual Models and Simulations

A virtual 3D model was modelled (Fig. 15.5) based on the first prototype (Fig. 15.6). This is quite useful because once a 3D virtual model is produced, design improvements and simulations can be done easily in a virtual environment before making expensive time-consuming prototypes. LCA can also be carried out simultaneously with the LCA built-in module of Solidworks.

**Fig. 15.5** 2D virtual model of the final concept selected

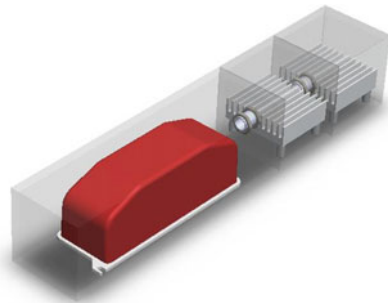

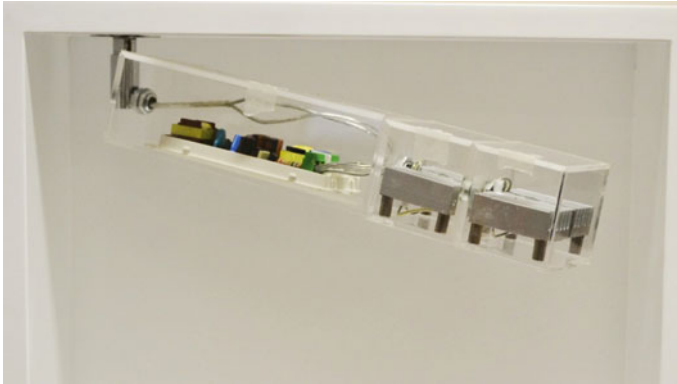
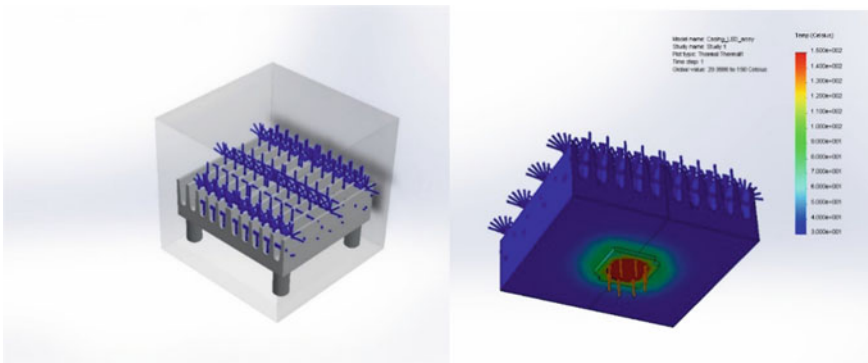

**Fig. 15.6** 3D physical model of the final selected concept

One of the advantages of modelling the lighting product with CAD software like Solidworks is that, once the product has been modelled, the Bill of Materials (BoM) is automatically created which is very useful to input the data fast and accurately in the LCA. In addition, when the design changes, the BoM will change automatically, this in turn will change the results of the LCA too.

**15.4.3.2 Thermal Analysis**

Once the lighting product is modelled in Solidworks, simulations can be conducted in its finite element analysis module to predict the behaviour of the product in the expected operating environment. A thermal analysis of the heat sink of the first prototype was conducted (Fig. 15.7) to find out if the heat sink design was thermally efficient. In the simulated conditions, a temperature of 150 °C was reached in the



**Fig. 15.7** Heat sink model analysed

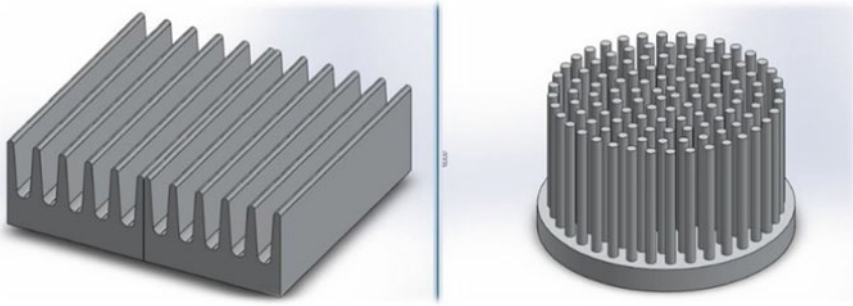

**Fig. 15.8** Previous and new heat sink design—iteration 4

LED, and the heat sink was exposed to an ambient temperature of 30 °C, so the heat conduction took place.

The results confirmed that the heat sink fulfilled its function of transferring the heat generated by the LED. The average temperature around the LED contact surface was between 70 °C to 50 °C, so the selected heat sink was over dimensioned for the requirements of this design, and hence, the heat sink had to be optimized to reduce its mass. The initial heat sink design (Fig. 15.8, left image) was replaced by another heat sink with round section with pins (Fig. 15.8, right image). The overall dimension of the heat sink was also changed to Ø60 mm.

The new heat sink design was analysed using Solidworks to assess its thermal performance (Fig. 15.9).

Results of the analysis confirmed that the new heat sink (Fig. 15.9) had increased its volume slightly from 16298 to 19263 mm<sup>3</sup>, the change was minimal, and the weight was reduced by 10%. The new heat sink had higher surface area: increased from 13886 to 23649 mm<sup>2</sup>. This improved the heat convection up to 50%. Hence,

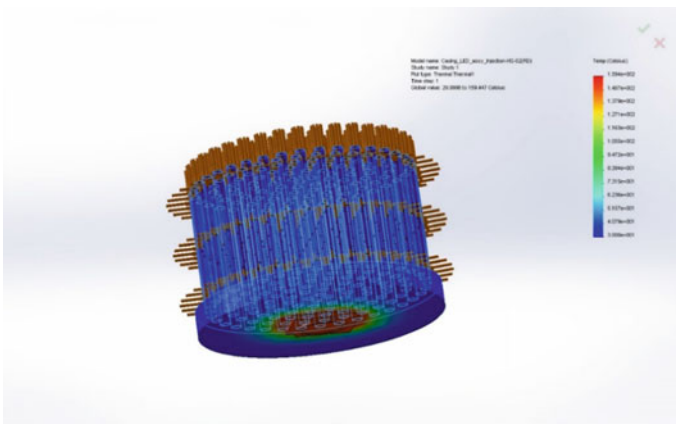

**Fig. 15.9** Results of the thermal analysis of the new heat sink

the new heat sink had a much better thermal performance with less weight, which could ensure a longer life, less failure rates and less maintenance costs of the LED component.

### 15.4.3.3 Comparative LCA and Final Embodied Design

The environmental impact of the final embodied design (Fig. 15.14) was assessed and compared (using LCA) with the prototype of the final concept selected (Fig. 15.6), which was used as a reference at the beginning of the embodiment design process. The aim of this assessment is to find out if the modifications implemented in the final embodied design has reduced the total environmental impact of the final concept selected, and in which life cycle stages and components this impact was allocated.

The assessment performed was a cradle to grave assessment which comprised all product life cycle stages (materials, manufacturing, distribution, use and end of life) of both lighting products, except the packaging, which had not been considered in the assessment. It had been assumed that both luminaires were distributed in the distance of 300 km by road in a delivery van of less than 3.5 tonnes capacity. The lifespan considered for both luminaires was 50,000 h which was based on the lifespan of the LED used as specified by the LED supplier.

The assessment was carried out using the LCA-based software tool Simapro and using the Eco-indicator 99 Life Cycle Impact Assessment (LCIA) method. The LCA results are further presented below.

The assessment was based on the following end point damage categories: Human Health, Ecosystem quality and Resources. The results showed that the prototype of the final concept selected (Fig. 15.6) had higher total environmental impact (Figs. 15.10 and 15.11) than the embodied final design (Fig. 15.14). The life cycle stages and components with the highest impact were: the 'use' and 'manufacturing' stages, where the final concept selected had higher environmental impact than the embodied design.

The higher impact of the 'use stage' was caused by using LEDs with higher Wattage (6 W vs. 4 W), and the higher impact of the 'manufacturing stage' was caused by the higher impact of the manufacturing of the housing, heat sink and driver. The LEDs had nearly the same impact (Figs. 15.12 and 15.13).

The life cycle stage with the highest impact was the 'use stage' in both, the final concept and the embodied design, which is typical in energy-consuming products, and lighting products in particular. The final embodied design had less environmental impact in the 'use' stage because it used LEDs with lower Wattage (4 W vs. 6 W) and allowed users to control the amount of light and energy used. Light quantity and intensity control was possible with the utilisation of dimmable drivers and the possibility to switch on/off each lighting module individually.

The manufacturing stage was the second life cycle stage with high impact, and all the components used in the final embodied design (except the LED that had similar impact) had substantially less environmental impact in comparison with the final concept design. This is because in the final embodied design less material was used, and also because the material used was shaped by fewer and more efficient

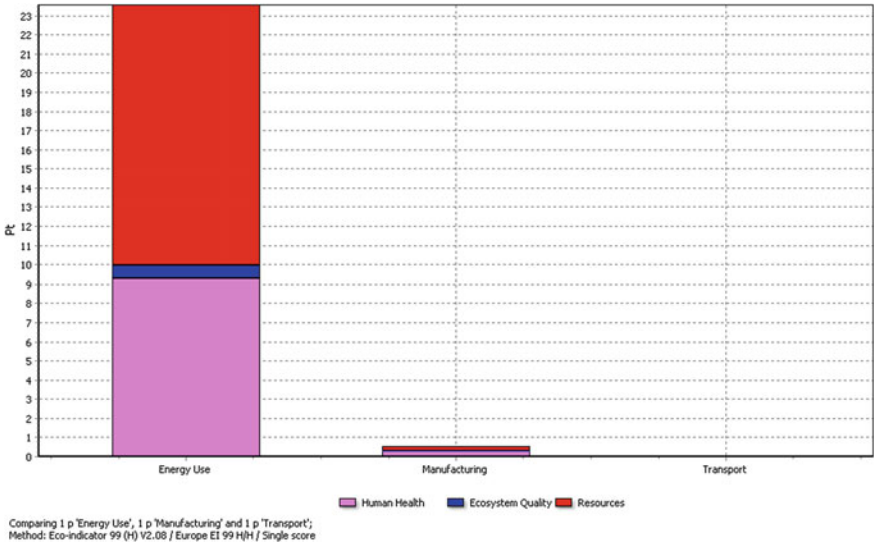

Fig. 15.10 Environmental impact of final concept selected life cycle stages based on end point damage category

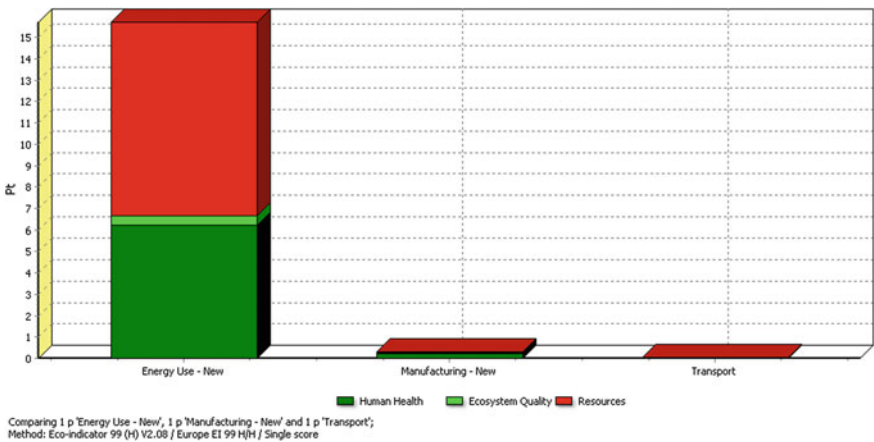
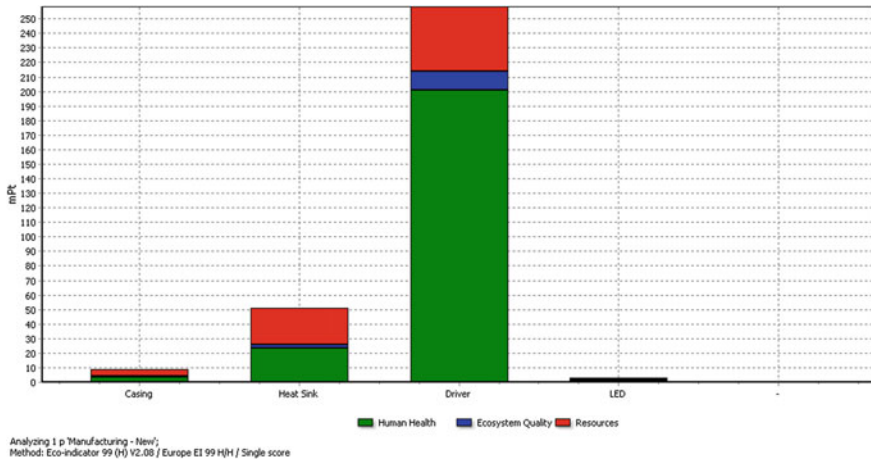
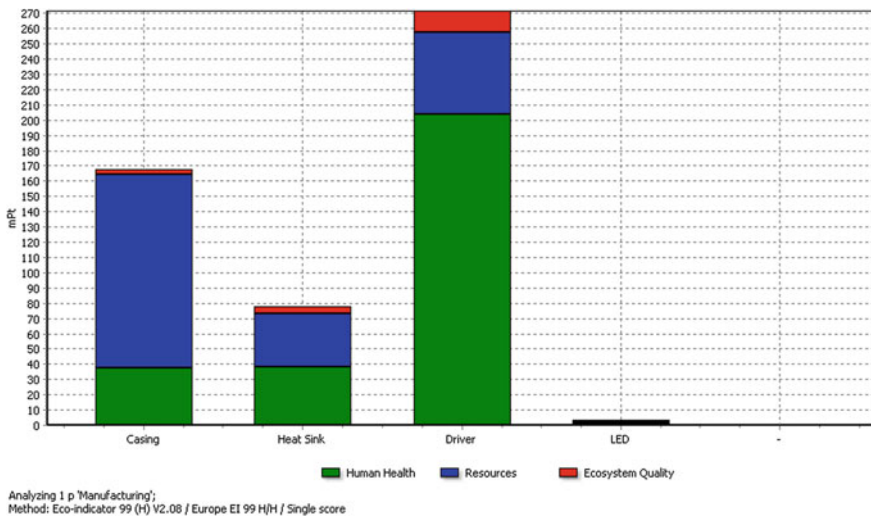

Fig. 15.11 Environmental impact of final embodied design life cycle stages based on end point damage category

(i.e. less use of material and energy to process) manufacturing processes. The new driver selected was lighter, and the new heat sink was lighter and more efficient (i.e. less energy consumption). The previous heat sink had to be extruded, cut and glued (2 parts), the new one was produced in one single process where all the parts were manufactured at the same time.



**Fig. 15.12** Environmental impact of the manufacturing stage of the final selected concept based on end point damage category



**Fig. 15.13** Environmental impact of the manufacturing stage of the final embodied design based on end point damage category

The design features of some parts of the final selected concept were too complex, and made the fabrication of the injection moulding dies too complicated and energy-intensive. The features and tolerances of some parts were modified, as suggested by the injection moulding dies manufacturer, to reduce the amount of parts (and material) used (Fig. 15.14).

**Fig. 15.14** Final embodied prototype



#### **15.4.4** *Detail Design*

During the detail design stage, the embodied design was defined in more detail to prepare the product for manufacture. This section explains the selection and specification of the final components, in order to reduce their environmental impact.

The final main components selected and used to make the final product are described below:

**LEDs:** The LEDs were compliant with RoHS directive.

**Driver:** Dimmable driver compatible with different current LED wattages and future LED wattages to ensure compatibility for a long time. The driver was selected with the LED-driver selector (Future Lighting Solutions Inc. 2018) in order to optimise the match between LED and driver to save energy. The dimmable driver was RoHS compliant.

**Circuit-control unit:** A circuit-control unit was designed (Fig. 15.15) for this application. This circuit-control unit controlled the potential use of sensors (e.g. motion/light sensors) and the dimming function using touch. This circuit could be programmed to perform several functions:

- Individual switch on/off of lighting modules.
- Dimming of lighting units by touch (touching the housing).



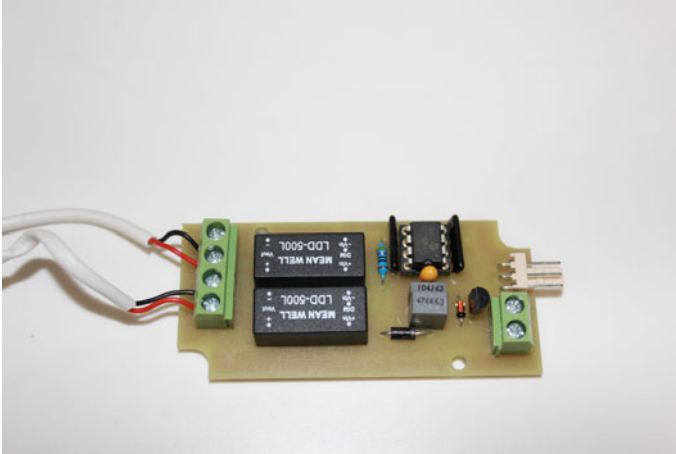

**Fig. 15.15** Circuit-control unit

- Switch on/off and dimming informed by sensors, for example, when the sensor detects movement it switches on/off or dim the luminaire.

**Heat sinks:** Heat sinks are essential components of LED-based lighting products because these are necessary to dissipate the high amount of heat produced by LEDs. High temperature is one of the main factors that shorten the LED lifespan, so heat dissipation through active or passive cooling is very important. After trying and testing, several heat sinks, as explained in previous sections, a final heat sink (Fig. 15.16) made of recycled aluminium was selected.

**Reflector:** Light reflectors and lenses (i.e. optic elements) are necessary to control the light direction. There is always light output loss when light is reflected, and this makes the luminaire less energy-efficient (i.e. less lumens/watts ratio). That is why the percentage of light reflected by the reflector has to be as high as possible. Figure 15.17 shows the reflector-lens combination selected. This was made of Poly-Methyl Methacrylate (PMMA) and the reflector had 85% reflectivity, which is a high reflectivity ratio, to save light loss and energy wasted.

**Fig. 15.16** Heat sink



**Fig. 15.17** Reflector-lens

### 15.4.5 Experiments

This section describes the experiments conducted by applying the experimental methods in the final embodied prototype, and how they contribute to reduce the environmental impact. The experimental methods applied include Light measurement methods, thermal measurement methods, burn-in test methods, Ingress Protection (IP) methods, and CE mark certification methods.

#### 15.4.5.1 Light Analysis Measurement

This test analysed the quantity and quality of light produced, and the power consumption. The light analysis test was conducted with a table lamp version with three lighting modules at 100% dimmer intensity.

The following parameters were obtained after the test:

- Light distribution: See polar diagram (Fig. 15.18, left image).
- Luminous Flux: 948 lm.
- Lighting product efficacy: 55.11 lm/W.
- Power consumption: 17.2 W.
- Light Output Ratio (LOR): 0.95.
- Color Correlated Temperature (CCT): 5000 K.
- Color Render Index (CRI): 65.
- Luminous flux of light source: 330 Lm (1 LED module).
- Light source efficacy: 49.25 lm/W.
- Light source useful lifetime: 50,000 h.

The reason why it is necessary to conduct the test and analysis of the lighting product, is because it is essential to know the light parameters of the lighting product. The parameters considered in this study include luminous flux (lm), power consumption (W), Colour Correlated Temperature (CCT) and light distribution, which are all directly related with the environmental impact of the lighting product. For example, if we know these parameters, we can obtain the luminous efficacy of the lighting product (lm/W), its Light Output Ratio (LOR), its power consumption and

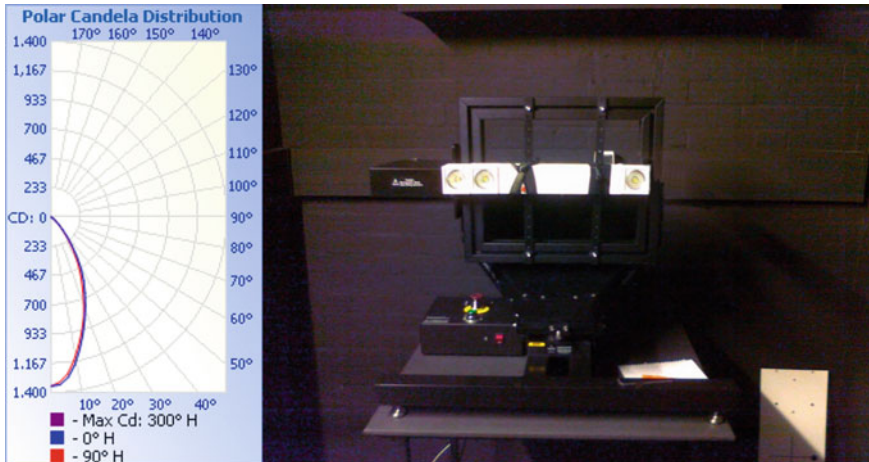

**Fig. 15.18** Light intensity distribution polar diagram of the lighting product (left image). Lighting product with three lighting modules mounted on the goniometer (right image)

the light distribution. The light distribution is necessary in order to use the lighting product efficiently. Often, light is wasted because architects and interior designers do not know how the lighting product distributes the light in the space. If the light distribution is known, then, it is possible to use the light more efficiently and save light (and energy). This analysis is also necessary to inform the final environmental impact assessment (with an LCA) of the final lighting product.

To conduct the light analysis and test, several tools were used: Goniometer (Radiant Vision Systems 2018a, b) (Fig. 15.18, right image), illuminance meter (Konica Minolta 2018a), colorimeter (Konica Minolta 2018b), power meter (Maplin 2018) and several software tools: ProSource (Radiant Vision Systems Radiant Vision Systems 2018a, b) and Photometrics Pro (J. Solutions Inc. 2003). The following standards were utilised in the light analysis: IES-LM-80-08 (IES 2008b) and TM-21-11 (IES 2011a) which are standards used by the LED suppliers. To analyse the light performance of the whole luminaire, IES-LM-79-08 (IES 2008a) standards were followed.

#### 15.4.5.2 Thermal Measurement

The thermal resistance test consisted of measuring the temperature inside the housing that contained the driver (driver module) and the housing containing the LEDs (lighting module), with a digital voltmeter and thermocouple (Fluke 180 series), to confirm the heat-resistance of the housing material (PET), and the lighting product's electronic components (LEDs and driver) inside the housings. The thermocouple sensors were placed inside the driver module and lighting module, and readings were taken every hour for a period of seven hours.

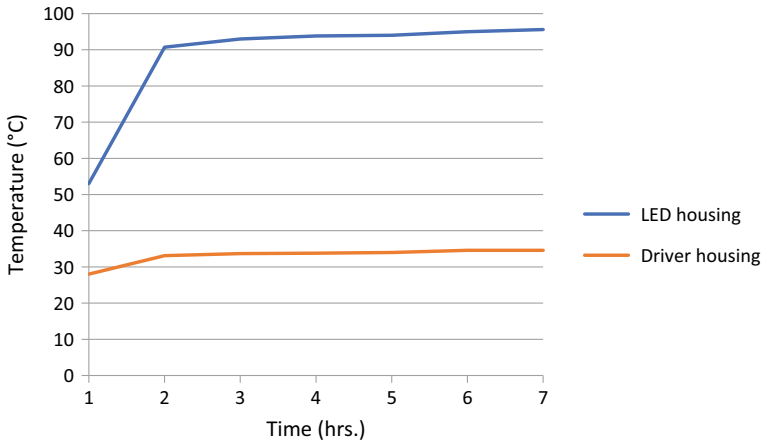

**Fig. 15.19** Temperature inside the lighting and driver modules (housing) over time

The test results are shown in Fig. 15.19, which indicate that the maximum temperature registered inside the driver module was 34.6 °C, and inside the lighting module was 95.6 °C. Both are well below the PET material melting point temperature (250 °C) (Ashby and Johnson 2010), and the recommended functional temperature of LEDs junctions 125 °C (Chwan 2012), so it was confirmed that the housing and components would not suffer any fast deterioration or failure inside the lighting product.

Although the thermal behaviour of the lighting product can be simulated in Solidworks virtually, the actual physical test should be conducted because this is the best manner to understand how the lighting product will behave thermally in real operating conditions. If this test would have shown temperatures above 125 °C or the PET material had shown signs of degradation that could affect its mechanical and optical properties, then the lighting product would have to be re-designed again. This test has to be conducted to increase the reliability of the lighting product, and hence its lifespan.

### 15.4.5.3 Other Experimental Methods Applied

In addition to the tests mentioned above, the following tests were conducted: Burn-in test, CE-mark test to obtain the CE certification, and IP44 test to obtain the IP44 certification.

**Burn-in test:** The aim of the burn-in test was to detect faulty components and systems which could lead to: (1) premature failure of the lighting product, or (2) premature degradation of components leading to lower performance of the lighting product. The test consisted of switching on the lighting product for 2,000 h. non-stop to confirm it worked with the expected performance after the test. After 2,000 h of

functioning, the product was fully functional with the expected performance, and no component failed during the test.

**CE mark test:** The CE mark test involves a series of tests following specific standards regarding safety. Although the purpose of this test is to comply with EU regulations, this certification also ensures a minimum set of quality standards that can increase the reliability and safety of the lighting product, therefore contributing to extend its lifespan and increase the well-being (Safety) of the end user. The CE test was conducted and several issues were raised that had to be re-designed to pass the test. For instance, the lighting modules could rotate more than 360° which was not safe as the cables that connect the modules could break. The lighting modules were re-designed so they could not rotate more than 360°.

**IP44 test:** The lighting product had to pass IP44 (IEC 2013) tests in order to reduce the possibility of components' failure due to external environmental effects (i.e. moisture, water). This test increased the reliability of the lighting product, and hence its lifespan. This test was also necessary to widen the scope of market niche and applications (i.e. use in toilets or terraces). This certification is required when the lighting product's intended use is in not very exposed outdoor environments and/or in humid indoor atmospheres such as toilets. The lighting product was exposed in a special chamber to water for a specific period of time, and after the test the interior compartment of the casing did not register or show any signs of water.

## 15.5 Discussion

This section discusses the advantages and disadvantages of the tools and methods applied in this approach.

### 15.5.1 *Eco-Design Guidelines*

#### 15.5.1.1 Advantages

The advantage of eco-design guidelines is that they are easy to apply, can cover different areas (e.g. disassembly, materials, manufacturing processes, regulations and directives, recycling), and do not require previous experience and knowledge about environmental issues to apply them. They can also be applied during the design process as checklists, to ensure that these are taken into account in each decision-making process (i.e. design iterations). Eco-design guidelines are especially useful at the beginning of the design process when no other eco-design tools can be used because there is no concept or prototype to be assessed yet.

### **15.5.1.2 Disadvantages**

The disadvantages are that they can only be used to recommend general eco-design actions, but cannot help to assess the environmental impact of a material, manufacturing process, concept or finished lighting product. In this sense, they cannot help to compare the environmental impact of two design decisions, or two design concepts or versions, and during the design process many times several design decisions have to be assessed and compared to select the one with less environmental impact. Another disadvantage is that eco-design guidelines can be too generic. This means that although they may recommend broad design guidelines, they do not provide concrete solutions or design recommendations for each particular case. In addition, since the recommendations are too broad, it is very difficult to assess if the product comply with these. For example, a particular eco-design guideline may recommend 'design the product so it is easy to recycle', however, this guideline does not specify how to achieve this, or specify a quantitative objective to achieve, which can then be evaluated at the end of the design process. They are easy to apply because they are general and simple, and at the same time, they are too general to be evaluated rigorously at the end of the process.

## ***15.5.2 LCA-Based Software Tools***

### **15.5.2.1 Advantages**

These tools can assess the environmental impact of a process, material, or product, which means that they can help the product designer to choose the material, manufacturing process, transport process, or other industrial process with the lowest environmental impact. This also means that they can be used to assess and compare design solutions (i.e. design features and full products). The results of the assessment of a product using this type of tools can provide information about: (1) total environmental impact of the product, (2) environmental impact of each life cycle stage, and (3) environmental impact of each part and component. This information can inform the product designer about which life cycle stages and components have the highest environmental impact, which can inform subsequent eco-design strategies to reduce the impact in these areas. Probably, the key advantage of this type of tools is that these are the only tools that can provide a relative accurate environmental impact assessment of a product or process in detail, which can support decision-making processes when having to decide which design solutions to choose.

### **15.5.2.2 Disadvantages**

The problem with this type of tools is that they are difficult to use because the user needs specific skills to use them, and the assessment is time consuming. In addition,

the quantity and quality of data required in each assessment is high, which is not always available at the early stages of the design process (i.e. concept design stage). The LCA of a product, during the design process, is partially based on assumptions, and the less defined the product is, the more assumptions have to be made, which means that the results are not totally accurate or reliable. For example, the assessment needs information about how many hours the lighting product will be functioning, and how it will be disposed, and this information has to be assumed, because it is not available, even when the lighting product is totally defined at the end of the design process.

It is also important to notice the differences between different types of LCA-based software tools. Streamlined/Screening LCA tools, such as Sustainable Minds, are tools developed for product designers, whilst detailed LCA tools, such as Simapro, have been developed for LCA experts. Although streamlined/screening LCA tools have an interface that is more user-friendly, and better adapted to answer product designers' needs, the results of the assessment are less accurate and the type of assessment cannot be as advanced (e.g. with end of life scenarios, and different assessment methods available) as the one conducted with detailed tools (e.g. Simapro). Assessments conducted with Simapro take more time, and require higher quantity and quality data, but the results are more accurate and reliable. Both types of tools cannot be applied at the beginning of the design process (i.e. PDS stage) when there is no lighting product (concept or prototype) to assess.

### ***15.5.3 Tools and Methods for Test and Analysis***

Different types of tools and methods have been applied in the tests and analysis (CE test, IP test, Burn-in test, thermal test, and light analysis test) conducted during the design process. The majority of these were originally designed with the aim to increase the reliability of the lighting product and its lifespan, which, indirectly, also contribute to reduce its environmental impact.

#### **15.5.3.1 Advantages**

Tests related with reliability (CE test, IP test, Burn-in test and thermal test) are usually utilised in many traditional design processes where there is no concern to reduce the environmental impact of the lighting product, so these are not new methods and tools. High-quality non-eco-lighting products are usually subject to the type of tests conducted in this design process, or even to additional tests. Many of these tests (e.g. CE, IP tests) are usually outsourced, and others (e.g. burn-in and thermal tests) that do not require especial (expensive) equipment and skills (or third party authorisation) are conducted in-house by product developers. Although many of these tests contribute to improve the reliability of the lighting product, they also contribute to enhance the

image of the product through the certifications (marks) provided after passing specific tests (e.g. CE, IP) successfully. These can increase the credibility of eco-products and enhance their sales.

The light analysis test, in addition to increasing the reliability of the lighting product, also provides the necessary information (e.g. luminous flux, power consumption, CCT) to conduct the environmental impact assessment with a LCA-based software tool such as Simapro. It also provides lighting product performance parameters such as luminous efficacy (lm/W) or Light Output Ratio (LOR), which are indicators of the energy efficiency of the lighting product. The light analysis test is usually outsourced, and conducted in traditional design processes of lighting products, so no previous knowledge and skills about this test is required from product designers.

### 15.5.3.2 Disadvantages

Although many of these tests (CE, IP, lighting tests) do not require the intervention of the product designer as they are outsourced, these are expensive and time-consuming, and many small companies cannot afford to include these in their design processes. In addition to this, these tests usually lead to further design changes (e.g. when the lighting product does not pass them), which will increase the duration and cost of the design process. Some of these tests, (thermal test, burn-in test) can be conducted by manufacturers in-house so they do not require extra cost, but they extend the duration of the design process too.

## 15.6 Conclusions

This chapter presented an approach which shows how to integrate eco-design methods and tools into the design process of lighting products. The approach is demonstrated using an LED lighting product developed by a lighting product manufacturer. In addition to this, it has discussed the advantages and disadvantages of the tools and techniques used in the approach. This approach provides a step-by-step design process which indicates which tools and methods to apply during the design process and when, in order to reduce the environmental impact of lighting products.

Due to the limitations related with the generalisation of findings from a single case study, the approach presented in this paper should be further validated, in future studies, with additional case studies with different types of users and contexts (e.g. company types) to validate and improve its effectiveness and usability.

**Acknowledgements** The authors acknowledge the financial support received from the financial support from the European Commission's CIP-EACIECO-INNOVATION programme for the Eco-lights project (grant no. ECO/11/304409). The authors also would like to thank Ona Product S.L. ([www.ona.es](http://www.ona.es)) for their support given to this research.



## References

- Ashby, M., & Johnson, K. (2010). *Materials and design: The art and science of material selection in product design*. 2nd ed. London: Butterworth-Heinemann.
- Bergendahl, C. G. (1995). *Handbook for design of environmentally compatible electronic products: An aid for designers*. Mölndal: IVF Research Publication 95851.
- Bhamra, T., & Lofthouse, V. (2007). *Design for sustainability: A practical approach*. Farnham: Ashgate Publishing.
- Billatos, B. B., & Basaly, A. N. (1997). *Green technology and design for the environment*. Washington: Taylor & Francis.
- Boks, C. (2006). The soft side of eco-design. *Journal of Cleaner Production*, 14, 1346–1356.
- Brezet, H., & Van Hemel, C. (1997). *EcoDesign: A promising approach to sustainable production and consumption*. France: UNEP.
- Byggeth, S., Broman, G., & Robert, K. H. (2007). A method for sustainable product development based on a modular system of guiding questions. *Journal of Cleaner Production*, 15, 1–11.
- Byggeth, S., & Hochschorner, E. (2006). Handling trade-offs in Ecodesign tools for sustainable product development and procurement. *Journal of Cleaner Production*, 14, 1420–1430.
- Casamayor, J. L., & Su, D. (2010a). Sustainable lighting product design: A new approach and an industrial case study. Sustainability in design now Conference, Bangalore, 29 September to 1 October. Sheffield: Greenleaf Publishing Limited.
- Casamayor, J. L., & Su, D. (2010b). Materials selection in sustainable lighting product design: An industrial case study. In 3rd conference on Advanced Design and Manufacture (ADM 2010), Nottingham, 8–10 September. Nottingham: Nottingham Trent University.
- Casamayor, J. L., & Su, D. (2011a). Environmental impact assessment of lighting products. *Key Engineering Materials Journal*, 486, 171–174.
- Casamayor, J. L., & Su, D. (2011b). Eco-design of lighting products: A study about integration of detailed/screening LCA software-based tools into design processes. In Ecodesign 2011: 7th symposium on environmentally conscious design and inverse manufacturing Conference, Kyoto, 30 November to 2 December. Berlin: Springer.
- Casamayor, J. L., & Su, D. (2013). Integration of eco-design tools into development of eco-lighting products. *Journal of Cleaner Production*, 47, 32–42.
- CELMA. (2011). Guide of the importance of lighting. Retrieved January 1, 2013, from <http://www.celma.org/home/index.php>.
- Charnley, F., Lemon, M., & Evans, S. (2011). Exploring the process of whole system Design. *Design Studies*, 32, 156–179.
- Chitale, A.K., & Gupta, R.C. (2007). *Product design and manufacturing*. 3rd ed. New Delhi: Prentice-Hall.
- Chwan, F. (2012). Calculate the LED lifetime performance in Optocouplers to predict reliability. White Paper Avago Technologies. [online]. Avago Technologies. Available at: <http://www.avagotech.com/docs/AV02-3401EN> [Accessed 10 October 2015].
- Charter, M., & Tischner, U. (2001). *Sustainable solutions: Developing products and services for the future*. Sheffield: Greenleaf publishing.
- Dassault Systemes. (2018). Solidworks software. Retrieved from <https://www.solidworks.com/sw/products/simulation/packages.htm>.
- Deutz, P., McGuire, M., & Neighbour, G. (2013). Eco-design practice in the context of a structured design process: an interdisciplinary empirical study of UK manufacturers. *Journal of Cleaner Production*, 39, 117–128.
- Dewulf, W. (2003). A pro-active approach to ecodesign: Framework and tools. Doctoral thesis, Catholic University of Leuven, Belgium.

- ECO SMEs, (2010). Eco-design guidelines. [online]. Eco SMEs. Available at: <http://www.ecosmes.net/cm/navContents?l=EN&navID=info&subNavID=1&pagID=6> [Accessed 10 May 2010]
- European Commission (EC). (2009). Energy Related Products (ErP) directive. Retrieved from <http://eur-lex.europa.eu/legal-content/EN/ALL/?uri=CELEX:32009L0125>.
- European Commission (EC). (2011). Restriction of Hazardous Substances (RoHS). Retrieved from <http://eur-lex.europa.eu/legal-content/EN/TXT/?uri=CELEX:32011L0065>.
- European Commission (EC). (2012). Waste Electrical and Electronic Equipment recycling (WEEE). Retrieved from [http://ec.europa.eu/environment/waste/weee/index\\_en.htm](http://ec.europa.eu/environment/waste/weee/index_en.htm).
- Fiksel, J. (2009). *Design for the environment: A guide to sustainable product development* (2nd ed.). New York: McGraw-Hill.
- Future Lighting Solutions Inc. (2018). LED driver selector on-line web-based application. Retrieved from: <http://www.futurelightingsolutions.com/en/development/Pages/index.aspx>.
- Garetti, M., Rosa, P., & Terzi, S. (2012). Life cycle simulation for the design of product-service systems. *Computers in Industry*, 63, 361–369.
- Ge, P. C., & Wang, B. (2007). An activity-based modelling approach for assessing the key stakeholders' corporation in the eco-conscious design of electronic products. *Journal of Engineering Design*, 18, 55–71.
- Gehin, A., Zwolinski, P., & Brissaud, D. (2008). A tool to implement sustainable end-of-life strategies in the product development phase. *Journal of Cleaner Production*, 16, 566–576.
- Giudice, F., La Rosa, G., & Risitano, A. (2006). *Product design for the environment. A life cycle approach*. Boca Raton: Taylor & Francis.
- Graedel, T. E., & Allenby, B. R. (1996). *Design for environment*. Upper Saddle River, NJ: Prentice Hall.
- Hanssen, O. J. (1999). Sustainable product systems—Experiences based on case projects in sustainable product development. *Journal of Cleaner Production*, 7, 27–41.
- Hinte, E. V. (2004). *Eternally yours: Time in design*. Rotterdam: 010 Publishers.
- IEC (International Electro Technical Commission). (2013). IEC 60529: Degree of protection provided by enclosures (IP Code). Retrieved from [https://global.ihs.com/doc\\_detail.cfm?rid=Z57&mid=5280&item\\_s\\_key=00035807](https://global.ihs.com/doc_detail.cfm?rid=Z57&mid=5280&item_s_key=00035807).
- IES (Illuminating Engineering Society), 2008a. IES LM-79-08: Approved Method: Electrical and Photometric Measurements of Solid-State Lighting Products. [online]. IES. Available at: <https://www.ies.org/store/product/approved-method-electrical-and-photometric-measurements-of-solidstate-lighting-products-1095.cfm> <https://www.ies.org/store/product/approved-method-electrical-and-photometric-measurements-of-solidstate-lighting-products-1095.cfm> [Accessed 10 August 2015].
- IES (Illuminating Engineering Society), 2011a. IES TM-21-11: Projecting Long Term Lumen Maintenance of LED Light Sources + Addendum A. [online]. IES. Available at: <https://www.ies.org/store/product/projecting-long-term-lumen-maintenance-of-led-light-sources-1253.cfm> [Accessed 10 August 2015].
- ISO. (2002). ISO/TR 14062:2002: Environmental management—Integrating environmental aspects into product design and development. Retrieved from [http://www.iso.org/iso/catalogue\\_detail?csnumber=33020](http://www.iso.org/iso/catalogue_detail?csnumber=33020).
- J. Solutions Inc. (2017). Photometrics pro software. Retrieved from <http://www.photometricspro.com/>.
- Jansen, A. J., & Stevels, A. L. N. (1998). The EPAss method, a systematic approach in environmental product assessment. Care Innovation conference, Vienna, 16–19 November, 1998.
- Jedlicka, W. (2009). Packaging sustainability: tools, systems, and strategies for innovative package design. Hoboken, N.J: John Wiley & Sons.
- Jedlicka, W. (2010). *Sustainable graphic design: Tools, systems, and strategies for innovative print design*. New York: John Wiley & Sons.
- Jensen, A. A., et al. (1997). *Life Cycle Assessment (LCA). A guide to approaches, experience and information sources* (Environmental series n6). Brussels: European Environment Agency.

- Kaebnick, H., & Sun, M. K. (2003). Sustainable product development and manufacturing by considering environmental requirements. *Robotics and computer integrated manufacturing*, *19*, 461–468.
- Kärnä, A. (2002). *Environmentally oriented product design—A guide for companies in the electrical and electronics industry* (2nd ed.). Helsinki: Federation of Finnish Electrical and Electronic Industry (SET).
- Kengpol, A., & Boonakit, P. (2011). The decision support framework for developing ecodesign at conceptual phase based upon ISO/TR14062. *International Journal of Production Economics*, *131*, 4–14.
- Knight, P., & Jenkins, J. O. (2009). Adopting and applying eco-design techniques: a practitioners' perspective. *Journal of Cleaner Production*, *17*, 549–558.
- Konica Minolta. (2018a). Illuminance meter T-10 A. Retrieved from: <http://www.konicaminolta.eu/en/measuring-instruments/products/light-display-measurement/illuminance-meters/t-10a/introduction.html>.
- Konica Minolta. (2018b). Colour meter CL-200 A. Retrieved from: <http://www.konicaminolta.eu/en/measuring-instruments/products/light-display-measurement/illuminance-colour-meters/cl-200a/introduction.html>.
- Le Pochat, S., Bertoluci, G., & Froelich, D. (2007). Integrating ecodesign by conducting changes in SMEs. *Journal of Cleaner Production*, *15*, 671–680.
- Lewis, H., et al. (2001). *Design and environment—A global guide to designing greener goods*. Sheffield: Greenleaf Publishing Limited.
- Lindahl, M. (2005). Engineering designers' requirements on design for environment methods and tools. Doctoral thesis, Royal Institute of Technology (KTH), Sweden.
- Lindahl, M. (2006). Engineering designers' experience of design for environment: Methods and tools and requirement definitions from an interview study. *Journal of Cleaner Production*, *14*, 487–496.
- Lofthouse, V. (2006). Ecodesign tools for designers: Defining the requirements. *Journal of Cleaner Production*, *14*, 1386–1395.
- Malmqvist, T., (2004). Real estate management with focus on the environmental issues. Licentiate Thesis, Royal Institute of Technology (KTH), Sweden.
- Maplin. (2018). 15A plug in energy saving monitor. Retrieved from: <http://www.maplin.co.uk/p/15a-plug-in-energy-saving-monitor-161a>.
- Maxwell, D., & Van Der Vorst, R. (2003). Developing sustainable products and services. *Journal of Cleaner Production*, *11*, 883–895.
- Maxwell, D., Sheate, W., & Van Der Vorst, R. (2006). Functional and systems aspects of the sustainable product and service development approach for industry. *Journal of Cleaner Production*, *14*, 1466–1479.
- Mcalonee, T., & Bey, N. (2009). *Environmental improvement through product development—A guide*. Denmark: Danish Environmental Protection Agency and Confederation of Danish Industry.
- Mcdonough, W., & Braungart, M. (2002). *Cradle to cradle: Remaking the way we make things*. New York: North Point Press.
- Mckinsey & Company. (2012). Lighting the way: Perspectives on the global lighting market. Retrieved from [https://www.mckinsey.de/files/Lighting\\_the\\_way\\_Perspectives\\_on\\_global\\_lighting\\_market\\_2012.pdf](https://www.mckinsey.de/files/Lighting_the_way_Perspectives_on_global_lighting_market_2012.pdf).
- Meinders, H.P. (1997). Point of no return. Philips EcoDesign guidelines - Philips fast 5 awareness. The Netherlands: Philips.
- Nielsen, P.H., & Wenzel, H. (2002). Integration of environmental aspects in product development: a stepwise procedure based on quantitative life cycle assessment. *Journal of Cleaner Production*, *10*, 247–257.
- Nordkil, T. (1998). Volvo black/grey/white lists. Volvo corporate standard. Sweden: Volvo.
- Niemann, J., Tichkiewitch, S., & Westkaemper, E. (2009). *Design of sustainable product life cycles*. Berlin: Springer.

- Papanek, V. (1998). *Design for the real world: Human ecology and social change* (2nd ed.). London: Thames & Hudson.
- Petala, E., et al. (2010). The role of new product development briefs in implementing sustainability: A case study. *Journal of Engineering and Technology Management*, 27, 172–182.
- Pigosso, C. A. D., et al. (2010). Ecodesign methods focused on remanufacturing. *Journal of Cleaner Production*, 18, 21–31.
- Platcheck, E. R., et al. (2008). Methodology of ecodesign for the development of more sustainable electro-electronic equipment. *Journal of Cleaner Production*, 16, 75–86.
- PRé. (2018). Simapro software. Retrieved from <http://www.pre-sustainability.com/simapro>.
- Radiant Vision Systems. (2018a). Goniometer PM-NFMS. Retrieved from <http://www.radiantvisionsystems.com/products/pm-nfms>.
- Radiant Vision Systems. (2018b). ProSource software. Retrieved from <http://www.radiantvisionsystems.com/products/application-software>.
- Rodrigo, J., & Castells, F. (2002). *Electrical and electronic practical ecodesign guide*. Tarragona: Rovira i Virgili University.
- Siemens. (2004). SIEMENS Norm - Product design, recycling, environmental protection, ecological compatibility and product development. Environmentally compatible products: Part 1: Product Development Guidelines. SIEMENS.
- Schmalz, J., & Boks, C. (2010). Sustainable, user behaviour centred design applying linked-benefits strategies: the logi desk lamp. In Knowledge Collaboration & Learning for Sustainable Innovation ERSCP-EMSU Conference, Delft, 25–29 October.
- Shedroff, N. (2009). *Design is the problem; the future of design must be sustainable*. New York: Rosenfield Media.
- Spangenberg, J. A., Fuad-Luke, A., & Blincoe, K. (2010). Design for Sustainability (DfS): The interface of sustainable production and consumption. *Journal of Cleaner Production*, 18, 1485–1493.
- Stevens, A. (2007). *Adventures in ecodesign of electronic products: 1993–2007*. Delft: Delft University of Technology—Design for Sustainability Program publication N° 17.
- Sustainable Minds. (2018). Sustainable Minds software. Retrieved from: <http://www.sustainableminds.com/software>.
- Tingstrom, J., & Karlsson, R. (2006). The relationship between environmental analyses and the dialogue process in product development. *Journal of Cleaner Production*, 14, 1409–1419.
- Tingstrom, J., Swanstrom, L., & Karlsson, R. (2006). Sustainability management in product development projects—The ABB experience. *Journal of Cleaner Production*, 14, 1377–1385.
- Tischner, U., Schmincke, E., & Rubik, F. (2000). *How to do ecodesign? A guide for environmentally and economically sound design*. Berlin: German Federal Environmental Agency.
- Ulrich, K. T., & Eppinger, S. D. (2008). *Product design and development* (4th ed.). New York: McGraw-Hill.
- UNEP & TU Delft. (2006). D4S design for sustainability. Retrieved from <http://www.d4s-de.org>.
- Van Der Zwan, F., & Bhamra, T. (2003). Alternative function fulfilment: Incorporating environmental considerations into increased design space. *Journal of Cleaner Production*, 11, 897–903.
- Vezzoli, C., & Manzini, E. (2008). *Design for environmental sustainability*. London: Springer.
- Vinodh, S., & Jayakrishna, K. (2011). Environmental impact minimisation in an automotive component using alternative materials and manufacturing processes. *Materials and Design*, 32, 5082–5090.
- Vinodh, S., & Rathod, G. (2010). Integration of ECQFD and LCA for sustainable product design. *Journal of Cleaner Production*, 18, 833–842.
- Waage, A. S. (2007). Re-considering product design: A practical “road-map” for integration of sustainability issues. *Journal of Cleaner Production*, 15, 638–649.
- Walker, S. (2006). *Sustainable by design*. London: Earthscan.
- Wenzel, H., Hauschild, M., & Alting, L. (1997). *Environmental assessment of products* (Vol. 1). London: Chapman Hall.

- Wimmer, W., Lee, K. M., Polak, J., & Quella, F. (2010). *Ecodesign: The competitive advantage*. Dordrecht: Springer.
- Wimmer, W., Züst, R., & Lee, K. (2004). *Ecodesign implementation: A systematic guidance on integrating environmental considerations into product development*. Dordrecht: Springer.
- Yarwood, J.M., & Eagan, P.D. (1998). *Design for the environment toolkit*. Minnesota: Office of Environmental Assistance; Minnesota Technical Assistance Program (MnTAP).

# Chapter 16

## Integrated Approach for Sustainable Flooring Product Development



Daizhong Su, You Wu, Wenjie Peng, Shuyi Wang, Shifan Zhu,  
and Qianren Zhang

**Abstract** This chapter is to illustrate the integrated approach for sustainable product development with a case study of a raised access flooring product which consists of a floor panel made of sheet moulding compound material, a support stringer and pedestals. The product development process presented in this chapter focuses on the sustainable production process, including elaboration of product design specification, conceptual design, detail design, prototyping and testing, and manufacture. The other phases of the product life cycle, such as product in service, and the end-of-life product treatment are also considered in the product life cycle assessment. Various sustainable methods, such as life cycle analysis and eco-manufacture, and tools, such as life cycle impact assessment and finite element analysis, are integrated in the production process.

**Keywords** Life cycle assessment · Raised access floor product · Sustainable design · Product design · Finite element analysis

---

D. Su (✉) · Y. Wu · W. Peng · S. Wang

School of Architecture, Design and the Built Environment, Advanced Design  
and Manufacturing Engineering Centre, Nottingham Trent University, Nottingham, UK  
e-mail: [daizhong.su@ntu.ac.uk](mailto:daizhong.su@ntu.ac.uk)

Y. Wu

e-mail: [you.wu@ntu.ac.uk](mailto:you.wu@ntu.ac.uk)

W. Peng

e-mail: [wnejie.peng@ntu.ac.uk](mailto:wnejie.peng@ntu.ac.uk)

S. Wang

e-mail: [shuyi.wang2015@my.ntu.ac.uk](mailto:shuyi.wang2015@my.ntu.ac.uk)

S. Zhu

College of Mechanical and Electrical Engineering, Harbin Engineering University, Harbin, China  
e-mail: [zhushifan@hrbeu.edu.cn](mailto:zhushifan@hrbeu.edu.cn)

Q. Zhang

Chongqing Polycomp International Corp, Chongqing, China  
e-mail: [zhangqianren@cpicfiber.com](mailto:zhangqianren@cpicfiber.com)

## 16.1 The Integrated Approach

The integrated approach for sustainable product development is presented in Chap. 1. This chapter is to illustrate the approach with a raised access flooring product (for introduction of this type of product, please see Chap. 14).

As shown in Fig. 16.1, this case study focus on the total production, which includes the elaboration of product design specification, conceptual design, detail design, prototyping and testing, and manufacture. The other phases of the product life cycle, such as product in service, and the end-of-life product treatment (recycle, reuse, and disposal) will be considered in the life cycle assessment.

As stated in Chap. 1, where the detailed description of the integrated approach is given, the tools and methods to be integrated into the product development process are not expected to be all the same in different applications, but could be various subject to the nature of particular applications. This case study utilises the methods and tools related to sustainable production.

**Sustainable Production Methods** The methods include LCIA methods which are detailed in Chap. 3, three-tier methods which is detailed in Chap. 1, as well as common methods such as finite element analysis and modular design. In particular, they include

- Elaboration of product design specifications (PDS) with sustainability constraints, such as reduction of product carbon footprints, energy/material consumption, waste, and contribution to climate change.

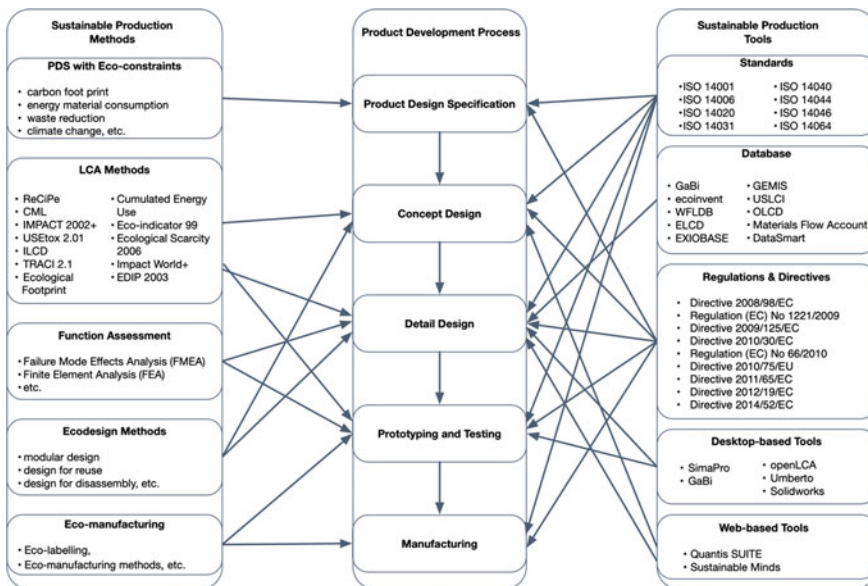

Fig. 16.1 Framework of the integrated approach for sustainable product development

- Product lifecycle impact assessment methods, such as ReCiPe, CML.
- Product failure analyses, such as failure mode and effect analysis (FMEA), and finite element analysis (FEA).
- Ecodesign methods, such as modular design, design for re-use, design for recycling.
- Eco-manufacturing, eco-labelling.

**Sustainable Production Tools** The tools involved include regulations, directives and standards which are detailed in Chap. 2; databases which are detailed in Chap. 3; LCIA tools, including desk top software packages and Web-based tools, which are detailed in Chap. 4, as well as other existing common tools. In particular, the tools include:

- Standards are requirements related to the production activities and quality of products characteristics.
- Regulations and directives are regulatory rules related to eco-design, recycling of wastes, pollutant emissions and reporting at voluntary and legislative level.
- Databases are data sources to support LCA and environmental performance reporting.
- Software tools (desktop based) are used to select sustainable materials and conduct comprehensive LCA.
- Software tools (web based) are used to conduct screening level sustainable design, environmental materials selection, and simple LCA.

## 16.2 Elaboration of Product Design Specifications

The sustainable flooring system is manufactured with Sheet Moulding Compound (SMC) and metal, and this case study introduces the process of developing this product system with the proposed integration framework and state-of-the-art tools.

The following sustainable constraints are elaborated during the PDS phase:

- The product needs to use the least number of components possible, whilst maintaining the required quality.
- Extending the product lifespan. The product should be durable and components should have easy access for installation and repair.
- Application of eco-design methods, such as modular design, design for easy repair and upgrade, design for disassembly, design for reuse.
- Designing the product system that facilitates components' recovery for reuse, re-manufacture and recycle.
- Using the minimum type of materials, which facilitates the sorting of components for reuse and recycling when the product reaches its end of service life.
- Using low environmental impact materials and manufacturing processes.
- Avoiding the use of special tools for disassembly, non-detachable joints (welded or glued joints), and toxic materials.



- The weight of a floor panel should not be more than 11 kg, in order to reduce the total load for transportation and, hence, reduce the energy consumption in transportation, as well as to reduce the load on the building.

The above PDS are derived from relevant directives, regulations and standards related to sustainable production in the EU. For example, the Environmental Impact Assessment Directive demands the companies to implement environmental impact assessment towards product life cycle, and to report the pollutant emissions related to manufacturing (European Commission 2014). Derived from this directive, the ‘Use low environmental impact materials and manufacturing processes’ is listed in the PDS.

### 16.3 Conceptual Design

In the conceptual design phase, the product concept was developed as shown in Fig. 16.1, in compliance with the sustainable PDS and regulations, directives, and standards that are directly linked with the flooring product quality and regulatory requirements, which are presented in Table 16.1.

Software SolidWorks is adopted to design the raised access floor system as it offers both the modelling function and the screening-level life cycle assessment. In addition, the BS EN 12825 requires the strength test (BSI 2001), once the modelling of the raised access floor system is completed, FEA can be conducted in the SolidWorks to examine the system’s strength performance.

SMC materials are selected for the floor panels in this project, because of its strong performance in mechanical properties, fire resistance, and stiffness. Its physical properties are presented in Table 16.2.

The modelling of the raised access floor system involves the design of a floor panel, a pedestal, and a pedestal cover, which are shown in Fig. 16.2. The dimensions of the pedestal unit and the floor panel are introduced in Table 16.2, which meet the criteria of the British Standard 12825 and PSA raised access floors performance specification. The pedestal design prevents excessive movement of the panel, by which the stability of the raised access floor system is strengthened.

The standard size for raised access floor panels is adopted to design the floor panel in this project, and its dimensions are also presented in Table 16.2. The weight of the floor panel is 25.92 kg, which is obtained by calculating the design dimensions and SMC density. This violates the weight constraint ( $\leq 11$  kg) defined in the PDS, and action has to be taken to reduce the weight to meet the constrain.

CML and TRACI are methodologies offered by the LCA package of SolidWorks (for further information, see Chap. 4). The CML method is adopted in this phase, and the screening-level results show that the materials contribute major negative impacts in the four environmental impact categories: 84% in Carbon Footprint, 91% in Total

**Table 16.1** The sustainable PDS, regulations, directives, and standards for the sustainable flooring product

<i>Compliance with the sustainable PDS</i>	
<i>PDS</i>	<i>Design features</i>
<ul style="list-style-type: none"> <li>• Use fewer components and low environmental impact materials</li> <li>• Using the minimum type of materials</li> <li>• Facilitating components' recovery for re-use, re-manufacture and recycle</li> </ul>	The floor system consists of one panel, one stringer and four pedestals, which are the minimum number of components for the system. The glass fibre filled polymer is used to produce the floor panel, because it not only has high performance in strength, cost and fire resistance properties, be also can be recycled to make cement. The material of the pedestal unit and stringer is steel, and it can be re-used or recycled
Increase product lifespan	Several strategies have been implemented to increase the flooring product lifespan: (1) increase the reliability of the product, (2) design the product for easy disassembly, (3) long warranty, (4) design a scheme to encourage the recycling of components
Easy to install the product	The flooring product system consists of a pedestal and a pedestal cover. The cover is placed on the top of the pedestal circular plate, which supports the accurate installation for the floor panel
Using the minimum type of materials	Only two types of materials used: SMC enforced with glass fibre for the floor pane and steel for stringer and pedestal
Avoiding the use of special tools for disassembly, non-detachable joints, and toxic materials.	The flooring system can be installed and disassembled using simple standard tools such as spanners. No toxic materials are used
<i>Compliance with the sustainable regulations, directives, standards</i>	
<i>Regulations, directives, and standards</i>	<i>Compliance</i>
EU waste framework directive	Information is provided to the user about the routs to recycle the product when it reaches the end-of-life stage
EU industrial emissions directive and environmental impact assessment directive	The manufacturer is to assess and report environmental performance related to manufacturing process and product life cycle. For this purpose, the detailed LCA is conducted at the end of the design
BS 476-Part 6 and 7—fire tests on building materials and structures	BS 476 Part 6 requires the floor panel to achieve Class O on fire propagation performance (BSI 1989), and BS 476 Part 7 requires the floor panel to achieve Class 1 on performance of resisting surface spread of flame (BSI 1997). Hence, the panel material selected must meet this fire resistance requirement
BS EN 12825—raised access floors	It states that the floor system must pass the work load test by measuring the deflection/deformation values, and the limited value is rated as Class A (2.5 mm), Class B (3.0 mm), Class C (4.0 mm) (BSI 2001). Hence the design of the floor system has to meet the requirement

**Table 16.2** Dimensions in conceptual design and the SMC physical properties

Items	Values
<i>Component dimensions in conceptual design</i>	
Height of pedestal	100 mm
Square base plate	100 mm × 100 mm
Diameter of circular plate at the top	90 mm
Size of the floor panel	600 mm × 600 mm × 40 mm
Weight of the floor panel	25.92 kg
<i>Physical properties of SMC</i>	
Density of the selected SMC	1800 kg/m <sup>3</sup>
Flexural modulus	1.3 GPa
Poisson's ratio	0.3
Yield strength	250 MPa
Tensile strength	150 MPa

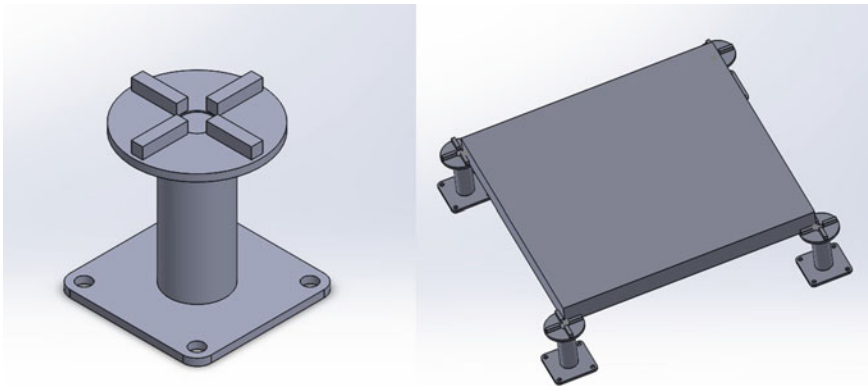
**Fig. 16.2** Conceptual design for the pedestal unit and the raised access floor system

Energy Consumed, 73% in Air Acidification, and 66% in Water Eutrophication. The pie charts of the LCA analysis results are shown in Fig. 16.3. However, the results only show the total negative impacts in the limited environmental impact categories, and the breakdowns of each impacts are not described, therefore user cannot identify the specific elements of the composites, or production processes causing high negative impacts. Consequently, the targets for design optimization and manufacturing improvement are not clearly shown.

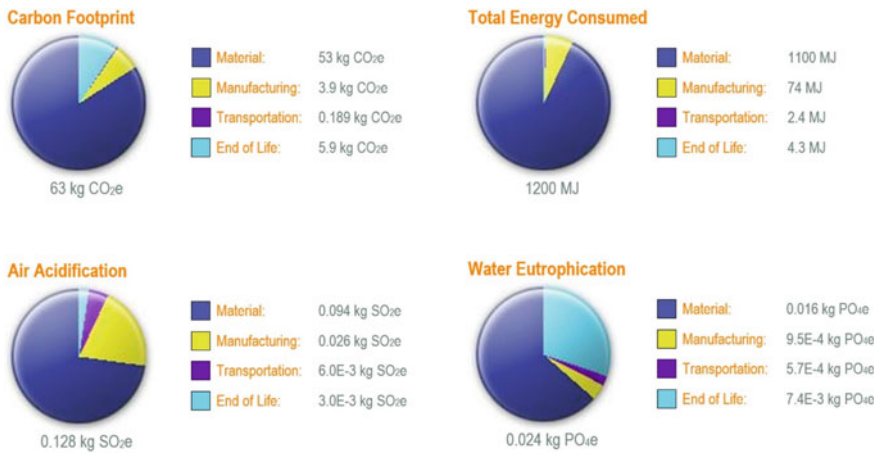

Fig. 16.3 The LCA results by adopting CML methodology in SolidWorks 2015

## 16.4 Detail Design

A key objective in the detail design phase is to mitigate the constraints identified in the concept design phase. Therefore, reducing the weight of the floor panel is the prioritized task in this phase. In addition, multiple advanced tools are utilized to perform detail design for the prototype and carry out a delicate LCA.

### 16.4.1 Refinement of the Raised Access Floor System

In order to achieve an effective design, the floor panel requires strong outer edges with the side of the panels connected by ribs, and, hence, the strategy of designing ribs for the floor panel is adopted. The optimum design of the floor panel has same size squares with 3 mm ribs between them. The layout and dimensions of these rectangles are shown in Fig. 16.4 and Table 16.3 respectively. The thickness of the floor panel is cut from 40 mm to 30 mm in the design comprising squares' size and ribs' thickness, therefore the strength performance of the floor panel is reduced. The solution of placing a steel stringer under the floor panel is adopted, as this design not only sustains the strength performance of the floor system, but also provides the facility of recycle or reuse for the steel stringer. The stringer design is shown in Fig. 16.4, and its dimensions are shown in Table 16.3.

With this optimum design, the total weight of this raised access floor system has been reduced to 8.06 kg, which is lighter than the average weight of a raised access flooring product. Figure 16.4 shows the raised access floor system after the refinement.

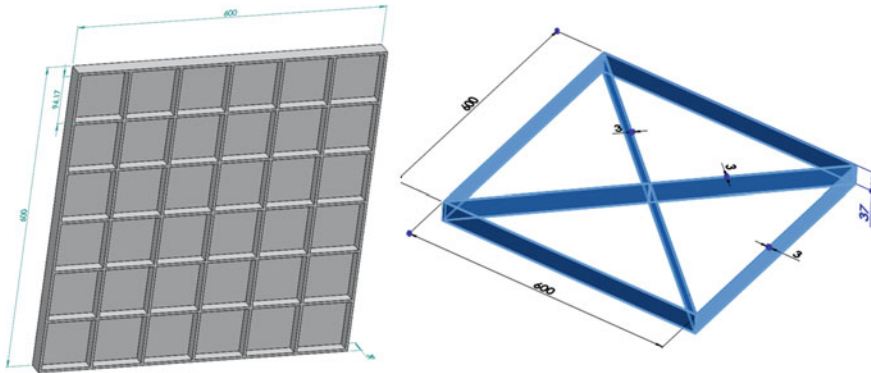

**Fig. 16.4** The design of the floor panel and stringer

**Table 16.3** Main components' dimensions and weight in detail design phase

Item	Value
<i>Component dimensions and weight in detail design</i>	
Square	94.7 mm × 94.7 mm × 94.7 mm
Thickness of ribs	3 mm
Thickness of the floor panel	30 mm
Size of the stringer	600 mm × 600 mm × 37 mm
Thickness of the string edge and beam	3 mm
<i>Component weight for detailed design</i>	
Floor panel	3.52 kg
Stringer	3.55 kg
Pedestal unit	0.99 kg
Total mass	8.06 kg

### 16.4.2 LCA of the Raised Access Floor System

According to the regulatory requirements, environmental performances of the raised access floor system are required to report, as mentioned in Table 16.1. In addition, the materials and manufacturing processes with high negative impacts through the product life cycle should be identified, with the aim to configure the optimization strategies for design iterations and production processes.

The environmental impact assessment of the raised access floor system is implemented by using the SimaPro with the ecoinvent database. ReCiPe methodology are adopted to conduct LCIA under the Cradle-to-Grave scenario towards the raised access floor system in this research (for further information, see Chap. 4 for SimaPro and Chap. 3 for ReCiPe and ecoinvent).

**Table 16.4** Percentages of recyclable materials in the waste scenario of England

Material	Waste treatment	Percentages
Glass	Recycling glass/RER U	46.5
Steel	Recycling steel and iron/RER U	46.6
Plastics	Recycling mixed plastics/RER U	2.7
Wood	Recycling/recovery in the England	42.3
PVC	Recycling PVC/RER U	2.7

### 16.4.2.1 Life Cycle Modelling

Considering the available data and objectives of this research, the examined life cycle processes of the raised access floor system include: Materials, Production, Distribution and End of Life, which are described as follows:

**Materials:** The main ingredients of SMC are glass fibre and polymers. The pedestal unit and stringer are manufactured with normal steel. The floor panel is packaged with wood pallets and PVC films.

**Production:** The examined processes of producing SMC include: heating of resin, and moulding which follows the information of the SMC product specification (Menzolit 2016). The examined processes of producing the floor panel include: heating, cutting ribs and edges. The examined processes of producing the pedestal unit and stringer include: extrusion of steel and steel turning.

**Distribution:** The examined distribution scenarios are from manufacturing site to retailers or construction sites in England, and this distance is an average of 200 km (suggested by the floor panel prototype manufacturer). The neglected distribution scenarios are the delivery of SMC ingredients from suppliers to manufacturers, and the delivery of packaging materials from suppliers to flooring product manufactures.

**End of Life:** This study refers for the waste treatment and management figures in England that are provided by the UK DEFRA (DEFRA 2015), and these statistics are compiled to comply with EC Waste Framework Directive (2008/98/EC). In this study, the waste treatment involves glass, steel, plastics, wood and PVC, and the percentages of recyclable materials are presented in Table 16.4. This means that the environmental impact evaluation of this scenario adopts the recycling percentages of each type of materials that are used in the product system. Hence, based on the descriptions presented above, the core activities and boundaries involved with the raised access floor system life cycle are mapped in Fig. 16.5.

### 16.4.2.2 Life Cycle Inventory Building

SMC ingredients' masses are obtained according to the material percentage revealed in the SMC production specification. The values of delivery distance, packaging weight, and machine energy consumption are provided by the manufacturer. Missing data is supplied by the ecoinvent 3.2 database, for example, LCI of pedestal unit, emissions of lorry transportation, electricity voltage for production in the England.

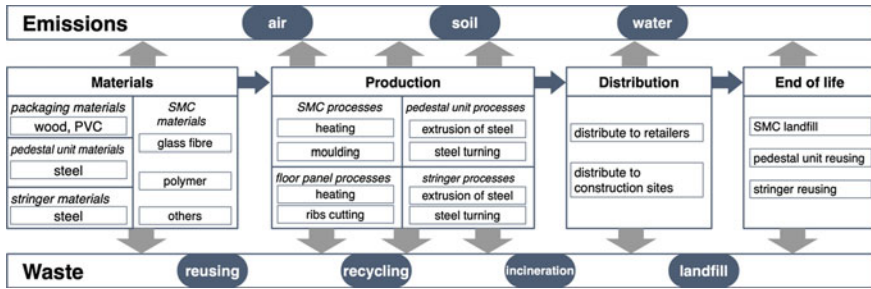

Fig. 16.5 Life cycle modelling of the raised access floor system

Table 16.5 LCI values of the raised access floor system

Materials/processes	Values	Units
Glass fibre	1.87	kg
Polymer	4.35	kg
Stringer	3.55	kg
Pedestal unit (steel)	0.993	kg
Packaging (wood pallet)	0.2	piece
Packaging (film)	0.47	kg
Transport distance	200	km
Transport weight	10	kg
Heating	2.1	kWh
Cutting	0.3	kg

The functional unit adopted in this study is one piece of raised access floor system, and the values of the inventories are presented in Table 16.5.

### 16.4.2.3 Life Cycle Impact Assessment

The network of analytical results is shown in Fig. 16.6, where a 2.4% cut-off is applied, i.e., any impacts with percentage <2.4% is not shown in the network diagram. Figure 16.7 only shows the partial network diagram to highlight the key flows of materials and processes, as the original completed diagram is too large for this paper layout. Each box in the network shows the name, weight, and percentage of the process/material in the whole life cycle, and all the numerical information is indicated by the thermometer within the box.

As Fig. 16.7 shows, within the total impacts, the major negative impacts are generated by the Materials (56.13%), and the Production (24.53%), Packaging (18.4%), and End of Life (3.52%) share 46.45% impacts in total. The distribution impacts are only shown (0.33%) with at least a 1.3% cut-off criteria.





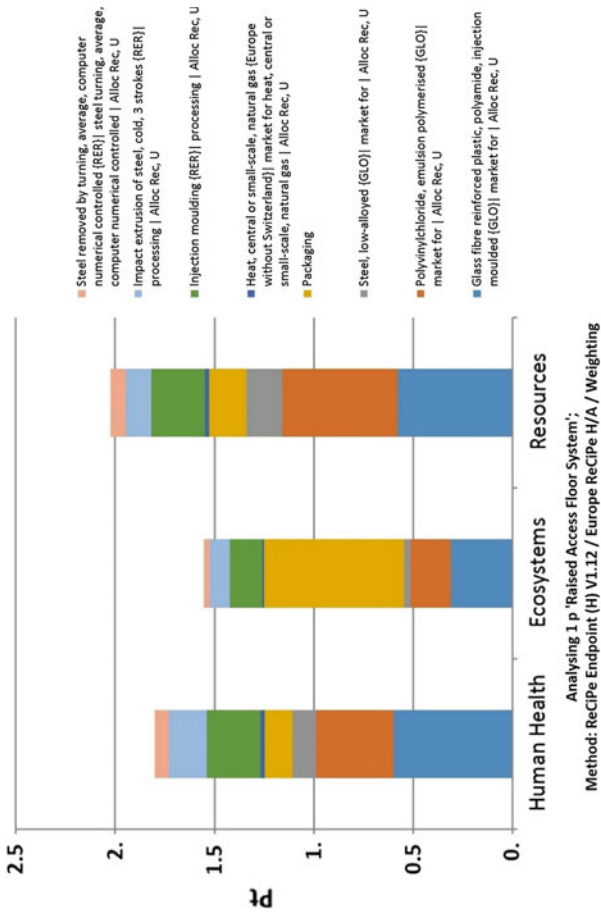

**Fig. 16.7** Weighting results in ReCiPe endpoint impacts for the raised access floor system

Within the Materials, glass fibre, polyvinylchloride, and steel contribute 26.7%, 21%, and 8.43% impacts respectively. It means the two components, the floor panel and pedestal unit, are allocated 47.7 and 8.43% impacts. Furthermore, among the materials producing the floor panel, the main impacts are caused by Nylon 6-6 (21.2%), which is also the main ingredient for producing the glass fibre.

Focusing on the Production, the SMC moulding (13.8%) and steel extrusion (7.47%) and turning (3.26%) have the highest environmental impacts. Within impacts caused by the packaging, the wood pallet and PVC film share 16.3% and 3.05% respectively. As the wood pallet is reusable, the negative impacts related to it are linked to its production stage (16%).

In terms of the End of Life for the raised access floor system, the environmental impact (3.52%) is not remarkable compared with the impacts that occur in Materials, Production, and Packaging, which shows that the adopted materials' recyclable performance is not remarkable.

Figure 16.7 shows the weighting results of the raised access floor system in end-point impact categories, which include Human Health, Ecosystems and Resources. It shows that Resources category (about 2.02 Pt) has the highest negative impacts, and the steel, polyvinylchloride, and glass fibre reinforced plastic cause the top 3 negative impacts, which are also the top 3 impact sources for the Human Health category (about 1.8 Pt). The Ecosystems category (about 1.5 Pt) contributes relatively small negative impacts, and the top 3 impact sources are Packaging, glass fibre reinforced plastic, and polyvinylchloride.

#### 16.4.2.4 Interpreting the Analysis Results

As the End of Life and Distribution share relatively small negative impacts (3.85%, 0.2155 Pt) in the life cycle of the raised access floor system, the target of design improvement should be placed at the Materials (56.13%, 3.13 Pt). The following strategies are proposed to achieve this objective through exploring the findings of the LCIA:

Table 16.6 shows the mass of negative impacts caused by the main flows within the three environmental impact categories, which could be used as benchmarking values in the next iterations of design. For example, in the case of investigating alternative main materials, the total mass (5.3787 Pt) of negative impacts can be used as the key benchmarking value to examine the potential material's environmental performance.

The Materials has the most negative impacts, and the Distribution stage has the smallest negative impacts, which is consistent with the analytical results offered by SolidWorks 2015 in the conceptual design phase. It shows the design improvement strategy on reducing the mass of materials is correct, and in order to achieve further design improvement, the design on the ribs and rectangles of floor panel could be elaborated, for example, reducing the thickness of ribs, or increasing the depth of each rectangles.

Glass fibre reinforced plastics have the most negative impacts among all the materials, therefore the alternative improvement strategy is to select the SMC composites

**Table 16.6** Mass of main flows with high environmental impacts, expressing benchmarking values for optimum design and production

Flows	Unit	Human Health	Ecosystems	Resources	Total
Glass fibre reinforced plastic, polyamide, injection moulded {GLO} market for Alloc Rec, U	Pt	0.5997	0.3134	0.5779	1.491
Steel, low-alloyed {GLO} market for Alloc Rec, U	Pt	0.119	0.0337	0.1822	0.3348
Polyvinylchloride, emulsion polymerised {GLO}  market for Alloc Rec, U	Pt	0.3909	0.2006	0.5814	1.1729
Packaging	Pt	0.1396	0.7033	0.1865	1.0294
Injection moulding {RER}  processing Alloc Rec, U	Pt	0.2718	0.1613	0.268	0.7012
Impact extrusion of steel, cold, 3 strokes {RER}  processing Alloc Rec, U	Pt	0.1888	0.101	0.1278	0.4177
Steel removed by turning, average, computer numerical controlled {RER}  steel turning, average, computer numerical controlled Alloc Rec, U	Pt	0.0723	0.0302	0.0797	0.1822
Heat, central or small-scale, natural gas {Europe without Switzerland} market for heat, central or small-scale, natural gas Alloc Rec, U	Pt	0.0183	0.0102	0.021	0.0496
Total	Pt				5.3787

with low glass fibre and polyvinylchloride in the SMC formulation, or to reduce the percentages of Nylon 6-6 in the glass fibre formulation, which contributes the highest impacts (21.2%) as shown in Fig. 16.7.

The Injection moulding process causes the highest negative impacts among all the production processes, so an improvement strategy would be to cut the overall moulding cycle time, and improve the mould speed.

It will be necessary to evaluate the proposed design improvement strategies, in order to test whether they can be implemented without compromising the physical properties required by the PDS, regulations and standards (e.g. fire resistance, strength). For example, although the recycling performance of SMC is low, other possible alternative materials are required to meet the fire resistance requirements.

As part of the ongoing project, diverse materials with different structures have also been proposed to design the raised access floor system, for example, paper core encapsulated by composite materials, balsa chipboard encapsulated by composite materials, and foam core encapsulated by composite material. The LCA will be used to evaluate the environmental performance of all these design solutions, and the solution with the lowest environmental performance would be commercialised in the European market.

## 16.5 Prototyping and Testing

In this phase, the prototype of the raised access floor system was tested and analysed to confirm that the final real product could meet the PDS, and pass all the tests identified in the conceptual and detail design phases, which include fire and strength tests. The prototype of the raised access floor system is shown in Fig. 16.8. The fire safety test must be conducted under controlled conditions, and by an external fire safety test company, which is not reported in this paper.



**Fig. 16.8** The prototype of the raised access floor product system (left) and the back of the floor panel (right)

### 16.5.1 Finite Element Analysis (FEA)

Finite Element Analysis is a well developed and widely accepted method to examine the strength performance of products or components. Therefore, FEA is utilised in this research to validate the flooring product of this project, and the FEA module of SolidWorks is used to assess the strengthen performance of the product in this phrase. The finite element methods used for examining the raised access floor system is a static and a linear system so that the linearity of relationship between the force and deflection of the floor system can be identified. The finite element method worked by breaking the computer model of the raised access floor system into smaller elements through the use of nodes and elements. Physical and geometric properties are allocated to the elements, and loads and displacements are applied to the nodes.

Two key indicators of FEA strength simulation are max yielding stress and max deformation. In terms of the ‘Maximum yielding stress criterion’, also called ‘Maximum distortion energy theory’, a flooring product starts to yield at a location when the maximum yielding stress becomes equal to the yielding strength, which is used as the stress limit. For the flooring product developed in this project, the yielding strength is obtained according to the physical properties of the floor panel and stringer. The maximum yielding stresses of the panel and stringer are required to be <94 MPa and 250 MPa, respectively, while the maximum deformation of the panel and stringer should be lower than 2.5 mm. According to the requirements of British Standards BSEN 12825:2001 (BSI 2001) and Platform Floors (Raised Access Floors) Performance Specification (PSA Specialist Services 1990), 3000 and 6000 N working loads are required to place on the central and edge of the floor system.

As shown in Figs. 16.9, 16.10, 16.11, 16.12 and 16.13, all the deformation values are <2.5 mm with 3000 N loading forces on the central and edge of the panel and stringer, which satisfy the flooring product’s deformation criteria of Class A, as defined by the British Standard requirements. Therefore, under 300 N of working

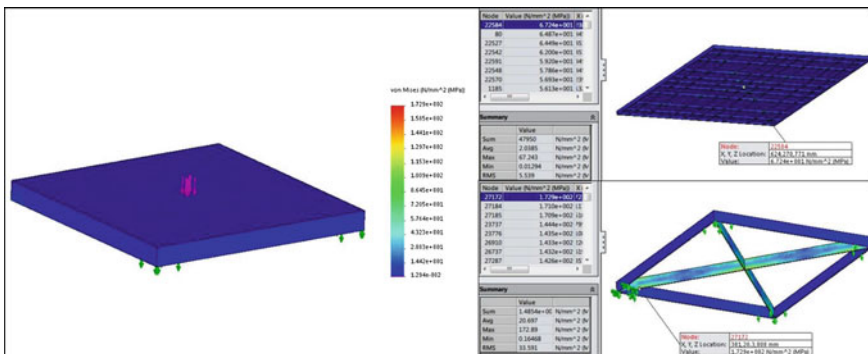

Fig. 16.9 Max yielding stress for the floor panel and stringer with loading 3000 N force at the central panel

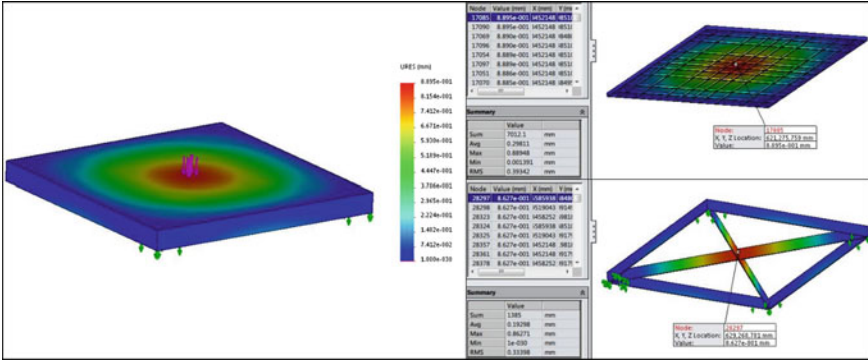

Fig. 16.10 Max deformation for the floor panel and stringer with loading 3000 N force at the centre panel

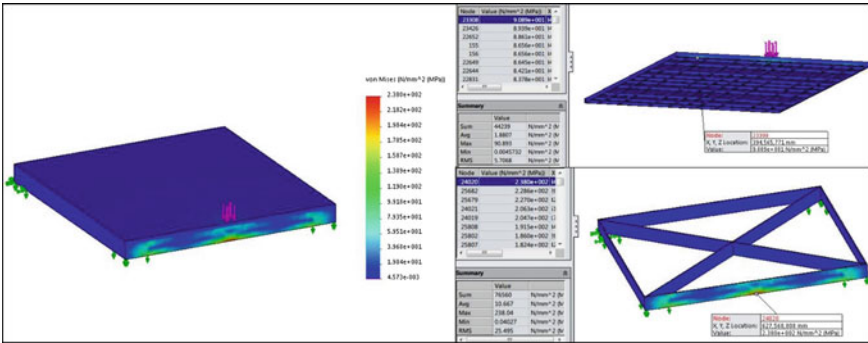

Fig. 16.11 Max yielding stress for the floor panel and stringer with loading 3000 N force at the outer edge of panel

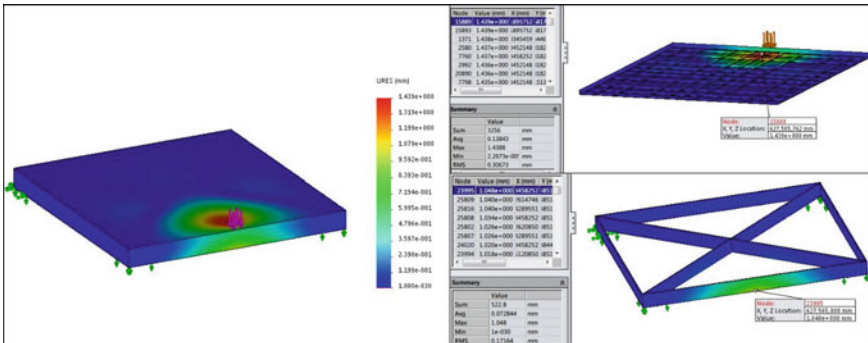
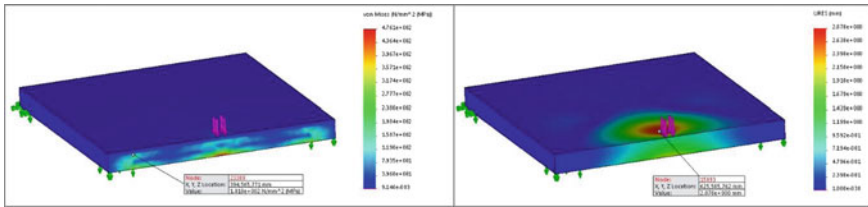

Fig. 16.12 Max deformation for the floor panel and stringer with loading 3000 N force at the outer edge of panel



**Fig. 16.13** Max yielding stress and deformation for the floor panel and stringer with loading 6000 N force at the outer edge of panel

load, the designed flooring product is able to work properly within the scope of elastic deformation.

As Fig. 16.13 shows, under 6000 N of ultimate working load, the maximum yielding stress and maximum deformation of the panel and string exceed the criteria of strength and deformation for the flooring products, therefore the floor panel will be broken down.

## 16.6 Strategies for Supporting Sustainable Manufacture

With the results obtained from the LCA, prototyping, test and FEA, it can be confirmed that the design of the raised access floor system meets the regulations, standards and PDS that have been incorporated in the conceptual and detailed design phases. Therefore, the flooring product will be produced by the industrial partner of the project. In order to achieve the sustainable production, the following are proposed:

- Avoid unnecessary heating time.
- Simplify the manufacturing process and use fewer processes, in order to reduce energy consumption and waste.
- Establish the recycle system for pedestal units and stringer, and provide information about how and where to dispose of the product.
- Increase the reuse rate of the wood pallet during the transportation of the product.
- Use local suppliers in order to reduce the impacts caused by the distribution of the product.
- Implement a long-term warranty.
- Register with an Environmental Management System (EMAS or ISO 14001) to improve environmental performance of the company's main activities.

## 16.7 Concluding Remarks

This chapter illustrates the integrated approach for sustainable product development using a raised access flooring product. This illustration is focused on elaboration of product design specification, conceptual design, detail design, prototyping and testing, and manufacture. The other phases of the product life cycle, such as product in service, and the end-of-life product treatment are considered in the LCA.

As a novelty of this research, it utilises the LCA analytical results as benchmarking values to examine environmental performance in the design iterations, and distilling LCA findings into methods and strategies to reduce the negative environmental impacts and improve resource efficiency in the production process.

This methodology's feasibility and functionality are approved via the case study. The new floor panel designed has achieved 44% weight reduction in comparison with the traditional raised access floor panel. The prototype passed the strength test and met environmental requirements stipulated by the regulations and standards on manufacturing floor products in the EU and UK market. ReCiPe methodology is adopted to evaluate the life cycle environmental performance of the flooring product, the results of which also identified the major negative impacts, which are related to the SMC material and moulding process.

The LCA results shows that the materials contribute significant impacts in the four environmental impact categories: 84% in carbon footprint, 91% in total energy consumed, 73% in air acidification, and 66% in water eutrophication. The results not only clarify the optimized design targets, but also enable to benchmark values for design iterations.

## References

- BSI, British Standard Institution. (2001). *BS EN 12825:2001—Raised access floors*. London.
- DEFRA. (2015). ENV23—UK statistics on waste. Retrieved June 5, 2016, from <https://www.gov.uk/government/statistical-data-sets/env23-uk-waste-data-and-management>.
- European Commission. (2014). Directive 2014/52/EU of the European Parliament and of the Council of 16 April 2014 amending Directive 2011/92/EU on the assessment of the effects of certain public and private projects on the environment Text with EEA relevance. Retrieved October 13, 2015, from <http://eur-lex.europa.eu/legal-content/EN/TXT/?uri=celex:32014L0052>.
- Menzolit. (2016). SMC: Menzolit moulding compounds. Retrieved July 24, 2016, from <http://www.menzolit.com/products/smc/>.
- PSA Specialist Services. (1990). *Platform Floors (Raised Access Floors) Performance Specification*. MOB Focal Point.