

Endocrinology

*Series Editor:* Andrea Lenzi

*Series Co-Editor:* Emmanuele A. Jannini

SPRINGER  
REFERENCE

Enzo Bonora

Ralph A. DeFronzo *Editors*

# Diabetes Complications, Comorbidities and Related Disorders

*Second Edition*

 Springer

---

# Endocrinology

**Series Editor**

Andrea Lenzi

Department of Experimental Medicine

Section of Medical Pathophysiology

Food Science and Endocrinology

Sapienza University of Rome

Rome, Italy

**Series Co-Editor**

Emmanuele A. Jannini

Department of Systems Medicine

University of Rome Tor Vergata

Rome, Italy

Within the health sciences, Endocrinology has an unique and pivotal role. This old, but continuously new science is the study of the various hormones and their actions and disorders in the body. The matter of Endocrinology are the glands, i.e., the organs that produce hormones, active on the metabolism, reproduction, food absorption and utilization, growth and development, behavior control, and several other complex functions of the organisms. Since hormones interact, affect, regulate, and control virtually all body functions, Endocrinology not only is a very complex science, multidisciplinary in nature, but is one with the highest scientific turnover. Knowledge in the Endocrinological sciences is continuously changing and growing. In fact, the field of endocrinology and metabolism is one where the highest number of scientific publications continuously flourishes. The number of scientific journals dealing with hormones and the regulation of body chemistry is dramatically high. Furthermore, Endocrinology is directly related to genetics, neurology, immunology, rheumatology, gastroenterology, nephrology, orthopedics, cardiology, oncology, gland surgery, psychology, psychiatry, internal medicine, and basic sciences. All these fields are interested in updates in Endocrinology.

The aim of the MRW in Endocrinology is to update the Endocrinological matter using the knowledge of the best experts in each section of Endocrinology: basic endocrinology, neuroendocrinology, endocrinological oncology, pancreas with diabetes and other metabolic disorders, thyroid, parathyroid and bone metabolism, adrenals and endocrine hypertension, sexuality, reproduction, and behavior.

More information about this series at <http://www.springer.com/series/14021>

---

Enzo Bonora • Ralph A. DeFronzo  
Editors

# Diabetes

## Complications, Comorbidities and Related Disorders

Second Edition

With 95 Figures and 64 Tables

 Springer

*Editors*

Enzo Bonora  
Division of Endocrinology, Diabetes  
and Metabolism  
University and Hospital Trust of Verona  
Verona, Italy

Ralph A. DeFronzo  
Diabetes Division, Diabetes Research Unit  
University of Texas Health Science Center  
San Antonio, TX, USA

ISSN 2510-1927

ISSN 2510-1935 (electronic)

ISBN 978-3-030-36693-3

ISBN 978-3-030-36694-0 (eBook)

ISBN 978-3-030-36695-7 (print and electronic bundle)

<https://doi.org/10.1007/978-3-030-36694-0>

1st edition: © Springer International Publishing AG, part of Springer Nature 2018

2nd edition: © Springer Nature Switzerland AG 2020

This work is subject to copyright. All rights are reserved by the Publisher, whether the whole or part of the material is concerned, specifically the rights of translation, reprinting, reuse of illustrations, recitation, broadcasting, reproduction on microfilms or in any other physical way, and transmission or information storage and retrieval, electronic adaptation, computer software, or by similar or dissimilar methodology now known or hereafter developed.

The use of general descriptive names, registered names, trademarks, service marks, etc. in this publication does not imply, even in the absence of a specific statement, that such names are exempt from the relevant protective laws and regulations and therefore free for general use.

The publisher, the authors, and the editors are safe to assume that the advice and information in this book are believed to be true and accurate at the date of publication. Neither the publisher nor the authors or the editors give a warranty, expressed or implied, with respect to the material contained herein or for any errors or omissions that may have been made. The publisher remains neutral with regard to jurisdictional claims in published maps and institutional affiliations.

This Springer imprint is published by the registered company Springer Nature Switzerland AG  
The registered company address is: Gewerbestrasse 11, 6330 Cham, Switzerland

---

## Series Preface

Is there an unmet need for a new MRW series in endocrinology and metabolism? It might not seem so! The vast number of existing textbooks, monographs and scientific journals suggest that the field of hormones (from genetic, molecular, biochemical and translational to physiological, behavioral, and clinical aspects) is one of the largest in biomedicine, producing a simply huge scientific output. However, we are sure that this new Series will be of interest for scientists, academics, students, physicians and specialists alike.

The knowledge in endocrinology and metabolism almost limited to the two main (from an epidemiological perspective) diseases, namely hypo/hyperthyroidism and diabetes mellitus, now seems outdated and closer to the interests of the general practitioner than to those of the specialist. This has led to endocrinology and metabolism being increasingly considered as a subsection of internal medicine rather than an autonomous specialization. But, endocrinology is much more than this.

We are proposing this series as the *manifesto* for “Endocrinology 2.0”, embracing the fields of medicine in which hormones play a major part but which, for various historical and cultural reasons, have thus far been “ignored” by endocrinologists. Hence, this MRW comprises “traditional” (but no less important or investigated) topics: from the molecular actions of hormones to the pathophysiology and management of pituitary, thyroid, adrenal, pancreatic and gonadal diseases, as well as less common arguments. Endocrinology 2.0 is, in fact, the science of hormones, but it is also the medicine of sexuality and reproduction, the medicine of gender differences and the medicine of well-being. These aspects of Endocrinology have to date been considered of little interest, as they are young and relatively unexplored sciences. But, this is no longer the case. The large scientific production in these fields coupled with the impressive social interest of patients in these topics is stimulating a new and fascinating challenge for endocrinologists.

The aim of the MRW in Endocrinology is thus to update the subject with the knowledge of the best experts in each field: basic endocrinology, neuroendocrinology, endocrinological oncology, pancreatic disorders, diabetes and other metabolic disorders, thyroid, parathyroid and bone metabolism, adrenal and endocrine

hypertension, sexuality, reproduction and behavior. We are sure that this ambitious aim, covering for the first time the whole spectrum of Endocrinology 2.0, will be fulfilled in this vast Springer MRW in Endocrinology Series.

Andrea Lenzi, M.D.

Series Editor

Emmanuele A. Jannini, M.D.

Series Co-Editor

---

## Volume Preface

Diabetes mellitus is associated with multiple microvascular (retinopathy, nephropathy, and neuropathy) and macrovascular complications (myocardial infarction, stroke, amputation). While the microvascular complications result in considerable morbidity, the macrovascular complications are the major cause of mortality. Patients with diabetes also experience a wide variety of other complications that affect all organ systems in the body, including dementia, typical as well as atypical opportunistic infections, bone and joint disease, liver (NASH/NAFLD) and gall bladder disease, increased incidence of specific malignancies, skin pathologies, and others. The microvascular and macrovascular complications can be linked to hyperglycemia and hypertension/dyslipidemia/insulin resistance, respectively, but the etiologic factors responsible for many of the other diabetes-related complications remain to be evaluated. All organs are afflicted by diabetes and prevention of organ damage is essential to improve the quality of life, reduce the financial burden that accompanies these many varied and diverse complications, and prevent the days of life that are lost as a result of these complications. As much as 80–90% of the direct cost of diabetes care is related to treatment of the chronic complications of the disease.

In this volume, the acute and chronic complications of diabetes are reviewed and their etiology and treatment are discussed by experts in the field. The reader will be impressed by the in-depth coverage of the pathophysiology of the individual complications and the pragmatic approach to treat their clinical manifestations.

Verona, Italy  
San Antonio, TX, USA

Enzo Bonora  
Ralph A. DeFronzo  
Editors



---

# Contents

<b>1 Diabetes and Obesity</b> .....	1
Matthias Blüher and Michael Stumvoll	
<b>2 Diabetes and Dyslipidemia</b> .....	51
Henry N. Ginsberg, Maryam Khavandi, and Gissette Reyes-Soffer	
<b>3 Metabolic Syndrome</b> .....	71
Scott M. Grundy	
<b>4 Hypertension and Diabetes</b> .....	109
Colleen Majewski and George L. Bakris	
<b>5 Diabetes and the Cardiovascular System</b> .....	131
Mauro Rigato, Gian Paolo Fadini, and Angelo Avogaro	
<b>6 Pathogenesis of Microvascular Complications</b> .....	161
Mogher Khamaisi, George L. King, Kyoungmin Park, and Qian Li	
<b>7 Diabetes and the Kidney</b> .....	203
Anna Solini and Pietro Castellino	
<b>8 Diabetes and the Eye</b> .....	231
Massimo Porta and José Cunha-Vaz	
<b>9 Diabetes and the Nervous System</b> .....	275
Aaron I. Vinik, Carolina Casellini, and Serina Neumann	
<b>10 Diabetic Foot</b> .....	355
Frank Lee Bowling and Andrew J. M. Boulton	
<b>11 Diabetes and Cancer</b> .....	377
Riccardo Vigneri and Laura Sciacca	
<b>12 Bone and Diabetes</b> .....	411
Jakob Starup-Linde and Søren Gregersen	
<b>13 Diabetes and the Skin</b> .....	437
P. Gisondi, A. C. Fostini, and G. Girolomoni	

<b>14</b>	<b>Diabetes and Periodontal Disease</b> .....	451
	Thomas W. Oates and Namita Khandelwal	
<b>15</b>	<b>Diabetes and Sexual Disorders</b> .....	473
	Maria Ida Maiorino, Giuseppe Bellastella, and Katherine Esposito	
<b>16</b>	<b>Diabetes and NAFLD</b> .....	495
	Giovanni Targher, Alessandro Mantovani, and Enzo Bonora	
<b>17</b>	<b>Diabetes Secondary to Pancreatic Diseases</b> .....	523
	Teresa Mezza, Francesca Cinti, and Andrea Giaccari	
<b>18</b>	<b>Impact of Drugs on Diabetes Risk and Glycemic Control</b> .....	541
	Simona Frontoni and Fabiana Picconi	
<b>19</b>	<b>Diabetes Secondary to Endocrine Disorders and PCOS</b> .....	575
	Paolo Moghetti	
<b>20</b>	<b>Hyperglycemic Crises: Diabetic Ketoacidosis and Hyperglycemic Hyperosmolar State</b> .....	595
	Guillermo E. Umpierrez	
<b>21</b>	<b>Hypoglycemia</b> .....	615
	Carmine G. Fanelli, Paola Lucidi, Geremia B. Bolli, and Francesca Porcellati	
<b>22</b>	<b>Pregnancy and Diabetes</b> .....	653
	Riki Bergel, Eran Hadar, Yoel Toledano, and Moshe Hod	
<b>23</b>	<b>Diabetes, Depression, and Cognitive Disorders</b> .....	687
	Richard I. G. Holt	
<b>Index</b> .....		715

---

## About the Editors



**Enzo Bonora** M.D., Ph.D., Board Certified in Internal Medicine, Endocrinology, and Diabetes and Metabolic Diseases.

Full Professor of Endocrinology, University of Verona, Verona, Italy.

Director, School of Specialization in Endocrinology and Metabolic Diseases, University of Verona, Verona, Italy.

Coordinator, Doctorate in Clinical and Experimental Medical Sciences, University of Verona, Verona, Italy.

Coordinator, Integrated Course of Systematic Pathology II, School of Medicine, University of Verona, Verona, Italy.

Head, Section of Endocrinology, Diabetes and Metabolism, Department of Medicine, University of Verona, Verona, Italy.

Chief, Division of Endocrinology, Diabetes and Metabolism, Department of Medicine, University Hospital of Verona, Verona, Italy.

Scientific activities mainly in the fields of (a) epidemiology of diabetes and related conditions; (b) risk factors of type 2 diabetes and its chronic complications; (c) pathophysiology of type 2 diabetes (impaired insulin secretion and insulin resistance) and related conditions (e.g., metabolic syndrome); (d) obesity and fat distribution in humans and their metabolic and cardiovascular impact; and (e) therapy of diabetes and related conditions.

Author or coauthor of about 300 full-length papers in peer-reviewed journals (Impact Factor: about 2,500; citations: about 15,000; H-index: about 60) and a further 150 papers, reviews, and chapters of books.

More than 500 invited lectures and seminars in international and national congresses and meetings as well as in public and private institutions.

“Outstanding Scientific Achievement Award” from the Italian Diabetes Society in 1992.

“Michaela Modan Memorial Award” from the American Diabetes Association in 1997.

President, Italian Diabetes Society 2014–2016. President, Diabetes Research Foundation 2016–2018.



**Ralph A. DeFronzo, M.D.**, is Professor of Medicine and Chief of the Diabetes Division at the University of Texas Health Science Center and the Deputy Director of the Texas Diabetes Institute, San Antonio, Texas. Dr. DeFronzo is a graduate of Yale University (BS) and Harvard Medical School (MD) and did his training in Internal Medicine at the Johns Hopkins Hospital. He completed fellowships in Endocrinology at the National Institutes of Health and Baltimore City Hospitals and in Nephrology at the Hospital of the University of Pennsylvania. Subsequently, he joined the faculty at the Yale University School of Medicine (1975–1988) as an Assistant/Associate Professor. From 1988 to present Dr. DeFronzo has been Professor of Medicine and Chief of the Diabetes Division at the University of Texas Health Science Center at San Antonio. He also serves as the Deputy Director of the Texas Diabetes Institute.

His major interests focus on the pathogenesis and treatment of type 2 diabetes mellitus and the central role of insulin resistance in the metabolic-cardiovascular cluster of disorders known collectively as the insulin resistance syndrome. Using the euglycemic insulin clamp technique in combination with radioisotope turnover methodology, limb catheterization, indirect calorimetry, and muscle biopsy, he has helped to define the biochemical and molecular disturbances responsible for insulin resistance in type 2 diabetes mellitus.

For his work in this area, Dr. DeFronzo received the prestigious Lilly Award (1987) by the American Diabetes Association (ADA), the Banting Lectureship (1988) by the Canadian Diabetes Association, the Novartis Award (2003) for outstanding clinical investigation worldwide, and many other national and international awards. He is also the recipient of the ADA's Albert

Renold Award (2002) for lifetime commitment to the training of young diabetes investigators. Dr. DeFronzo received the Banting Award from the ADA (2008) and the Claude Bernard Award from the EASD (2008). These represent the highest scientific achievement awards given by the American and European Diabetes Associations, respectively. In 2008, Dr. DeFronzo also received the Italian Diabetes Mentor Prize and the Philip Bondy Lecture at Yale. In 2009, he received the Presidential Award for Distinguished Scientific Achievement from the University of Texas Health Science Center at San Antonio. Dr. DeFronzo received the Outstanding Clinical Investigator Worldwide Award by CODHy (2012), the Outstanding Scientific Achievement Award from the American College of Nutrition (2014), the Samuel Eichold II Memorial Award for Contributions in Diabetes from the American College of Physicians (2015), the George Cahill Memorial Lecture from the University of Montreal (2015), and the Priscilla White Memorial Lecture from the Joslin Clinic & Brigham and Women's Hospital (2015). Most recently (2017), Dr. DeFronzo received the Hamm International Prize for his many seminal observations on the pathogenesis and treatment of type 2 diabetes and the Distinction in Endocrinology Award from the American College of Endocrinology. With more than 800 articles published in peer-reviewed medical journals, Dr. DeFronzo is a distinguished clinician, teacher, and investigator who has been an invited speaker at major national and international conferences on diabetes mellitus.

---

## Contributors

**Angelo Avogaro** Department of Medicine, Division of Metabolic Disease, University of Padova, Padua, Italy

**George L. Bakris** ASH Comprehensive Hypertension Center, Section of Endocrinology, Diabetes and Metabolism, The University of Chicago Medicine, Chicago, IL, USA

**Giuseppe Bellastella** Department of Advanced Medical and Surgical Sciences, University of Campania “Luigi Vanvitelli”, Naples, Italy

**Riki Bergel** Helen Schneider’s Hospital for Women, Rabin Medical Center, Petah-Tikva, Israel

Sackler Faculty of Medicine, Tel Aviv University, Tel Aviv, Israel

**Matthias Blüher** Department of Medicine, University of Leipzig, Leipzig, Germany

**Geremia B. Bolli** Section of Endocrinology and Metabolic Diseases, Department of Medicine, University of Perugia Medical School, Perugia, Italy

**Enzo Bonora** Division of Endocrinology, Diabetes and Metabolism, University and Hospital Trust of Verona, Verona, Italy

**Andrew J. M. Boulton** Division of Endocrinology, Diabetes and Gastroenterology, Faculty of Medicine, Biology and Health, University of Manchester, Manchester, UK

Manchester Royal Infirmary, Manchester, UK

Diabetes Research Institute, University of Miami, Miami, FL, USA

**Frank Lee Bowling** Division of Endocrinology, Diabetes and Gastroenterology, Faculty of Medicine, Biology and Health, University of Manchester, Manchester, UK

Division of Surgery, Manchester Royal Infirmary, Manchester, UK

**Carolina Casellini** Strelitz Diabetes Center and The Neuroendocrine Unit, Eastern Virginia Medical School, Norfolk, VA, USA

**Pietro Castellino** Department of Clinical and Experimental Medicine, University of Catania, Catania, Italy

**Francesca Cinti** Center for Endocrine and Metabolic Diseases, Fondazione Policlinico Universitario A. Gemelli IRCCS, Università Cattolica del Sacro Cuore, Rome, Italy

**José Cunha-Vaz** Association for Innovation and Biomedical Research on Light and Image (AIBILI) and University of Coimbra, Coimbra, Portugal

**Katherine Esposito** Department of Advanced Medical and Surgical Sciences, University of Campania “Luigi Vanvitelli”, Naples, Italy

**Gian Paolo Fadini** Department of Medicine, Division of Metabolic Disease, University of Padova, Padua, Italy

**Carmine G. Fanelli** Section of Endocrinology and Metabolic Diseases, Department of Medicine, University of Perugia Medical School, Perugia, Italy

**A. C. Fostini** Department of Medicine, Section of Dermatology and Venereology, University of Verona, Verona, Italy

**Simona Frontoni** Department of Systems Medicine; Unit of Endocrinology, Diabetes and Metabolism, S. Giovanni Calibita Fatebenefratelli Hospital, University of Rome Tor Vergata, Rome, Italy

**Andrea Giaccari** Center for Endocrine and Metabolic Diseases, Fondazione Policlinico Universitario A. Gemelli IRCCS, Università Cattolica del Sacro Cuore, Rome, Italy

**Henry N. Ginsberg** Department of Medicine, Irving Institute for Clinical and Translational Research, Columbia University Vagelos College of Physicians and Surgeons, New York, NY, USA

**G. Girolomoni** Department of Medicine, Section of Dermatology and Venereology, University of Verona, Verona, Italy

**P. Gisondi** Department of Medicine, Section of Dermatology and Venereology, University of Verona, Verona, Italy

**Søren Gregersen** Department of Endocrinology and Internal Medicine, Aarhus University Hospital, Aarhus, Denmark

**Scott M. Grundy** Center for Human Nutrition and Department of Internal Medicine, UT Southwestern Medical Center, Dallas, TX, USA  
Veterans Affairs Medical Center, Dallas, TX, USA

**Eran Hadar** Helen Schneider’s Hospital for Women, Rabin Medical Center, Petah-Tikva, Israel  
Sackler Faculty of Medicine, Tel Aviv University, Tel Aviv, Israel

**Moshe Hod** Helen Schneider's Hospital for Women, Rabin Medical Center, Petah-Tikva, Israel

Sackler Faculty of Medicine, Tel Aviv University, Tel Aviv, Israel

**Richard I. G. Holt** Human Development and Health Academic Unit, Faculty of Medicine, University of Southampton, Southampton, UK

**Mogher Khamaisi** Section of Vascular Cell Biology, Joslin Diabetes Center, Harvard Medical School, Boston, MA, USA

Institutes of Endocrinology, Diabetes and Metabolism and Internal Medicine D, Rambam Health Care Campus and RB Rappaport Faculty of Medicine-Technion, Haifa, Israel

**Namita Khandelwal** College of Dental Medicine, University of New England, Portland, ME, USA

**Maryam Khavandi** Department of Medicine, Bassett Medical Center, New York, NY, USA

**George L. King** Section of Vascular Cell Biology, Joslin Diabetes Center, Harvard Medical School, Boston, MA, USA

**Qian Li** Section of Vascular Cell Biology, Joslin Diabetes Center, Harvard Medical School, Boston, MA, USA

**Paola Lucidi** Section of Endocrinology and Metabolic Diseases, Department of Medicine, University of Perugia Medical School, Perugia, Italy

**Maria Ida Maiorino** Department of Advanced Medical and Surgical Sciences, University of Campania "Luigi Vanvitelli", Naples, Italy

**Colleen Majewski** ASH Comprehensive Hypertension Center, Section of Endocrinology, Diabetes and Metabolism, The University of Chicago Medicine, Chicago, IL, USA

**Alessandro Mantovani** Section of Endocrinology, Diabetes and Metabolism, Department of Medicine, University of Verona, Verona, Italy

**Teresa Mezza** Center for Endocrine and Metabolic Diseases, Fondazione Policlinico Universitario A. Gemelli IRCCS, Università Cattolica del Sacro Cuore, Rome, Italy

**Paolo Moghetti** Unit of Endocrinology, Diabetes and Metabolism, Department of Medicine, University of Verona and Azienda Ospedaliera Universitaria Integrata Verona, Verona, Italy

**Serina Neumann** Psychiatry and Behavioral Sciences/Behavioral Medicine Program/Therapeutic Brain Stimulation Program, Eastern Virginia Medical School, Norfolk, VA, USA



**Thomas W. Oates** Department of Advanced Oral Sciences and Therapeutics, University of Maryland, Baltimore, MD, USA

**Kyoungmin Park** Section of Vascular Cell Biology, Joslin Diabetes Center, Harvard Medical School, Boston, MA, USA

**Fabiana Picconi** Department of Systems Medicine; Unit of Endocrinology, Diabetes and Metabolism, S. Giovanni Calibita Fatebenefratelli Hospital, University of Rome Tor Vergata, Rome, Italy

**Francesca Porcellati** Section of Endocrinology and Metabolic Diseases, Department of Medicine, University of Perugia Medical School, Perugia, Italy

**Massimo Porta** Diabetic Retinopathy Centre, Department of Medical Sciences, University of Turin, Turin, Italy

**Gisette Reyes-Soffer** Department of Medicine, Columbia University Vagelos College of Physicians and Surgeons, New York, NY, USA

**Mauro Rigato** Diabetology Service, Treviso, Italy

**Laura Sciacca** Endocrinology, Department of Clinical and Experimental Medicine, University of Catania, Garibaldi-Nesima Hospital, Catania, Italy

**Anna Solini** Department of Surgical, Medical, Molecular and Critical Area Pathology, University of Pisa, Pisa, Italy

**Jakob Starup-Linde** Department of Endocrinology and Internal Medicine, Aarhus University Hospital, Aarhus, Denmark

**Michael Stumvoll** Department of Medicine, University of Leipzig, Leipzig, Germany

**Giovanni Targher** Section of Endocrinology, Diabetes and Metabolism, Department of Medicine, University of Verona, Verona, Italy

**Yoel Toledano** Helen Schneider's Hospital for Women, Rabin Medical Center, Petah-Tikva, Israel

Sackler Faculty of Medicine, Tel Aviv University, Tel Aviv, Israel

**Guillermo E. Umpierrez** Department of Medicine, Division of Endocrinology and Metabolism, Emory University School of Medicine, Atlanta, GA, USA

**Riccardo Vigneri** Endocrinology, Department of Clinical and Experimental Medicine, University of Catania, Garibaldi-Nesima Hospital, Catania, Italy

**Aaron I. Vinik** Strelitz Diabetes Center and The Neuroendocrine Unit, Eastern Virginia Medical School, Norfolk, VA, USA



# Diabetes and Obesity

1

Matthias Blüher and Michael Stumvoll

## Contents

Introduction .....	2
Definition of Obesity .....	3
Definition and Classification of Diabetes .....	4
Epidemiology of Obesity and Diabetes .....	6
Pathophysiology of Obesity and Diabetes .....	8
Genetics of Obesity and Diabetes .....	11
Obesity: A Major Risk Factor for Type 2 Diabetes .....	13
Role of Glucose Toxicity .....	15
Role of Lipotoxicity .....	15
Role of Insulin Resistance .....	16
Body Fat Distribution and Risk for Type 2 Diabetes .....	17
Role of Adipose Tissue Dysfunction: A Mechanistic Link Between Obesity and Type 2 Diabetes .....	18
Prevention of Obesity and Type 2 Diabetes .....	24
Management of Obesity .....	25
Treatment of Obesity in Patients with Type 2 Diabetes .....	30
Behavior Modifications .....	32
Diets for Weight Loss .....	33
Increasing Physical Activity .....	35
Antidiabetic Medications and Body Weight .....	35
Pharmacotherapy of Obesity .....	36
Bariatric and Metabolic Surgery .....	39
Conclusions .....	42
References .....	42

---

M. Blüher · M. Stumvoll (✉)

Department of Medicine, University of Leipzig, Leipzig, Germany

e-mail: [Matthias.Blueher@medizin.uni-leipzig.de](mailto:Matthias.Blueher@medizin.uni-leipzig.de); [bluma@medizin.uni-leipzig.de](mailto:bluma@medizin.uni-leipzig.de); [michael.stumvoll@medizin.uni-leipzig.de](mailto:michael.stumvoll@medizin.uni-leipzig.de); [michael.stumvoll@uniklinik-leipzig.de](mailto:michael.stumvoll@uniklinik-leipzig.de)

© Springer Nature Switzerland AG 2020

E. Bonora, R. A. DeFronzo (eds.), *Diabetes Complications, Comorbidities and Related Disorders*, Endocrinology, [https://doi.org/10.1007/978-3-030-36694-0\\_1](https://doi.org/10.1007/978-3-030-36694-0_1)

1

---

**Abstract**

The prevalence of obesity and diabetes has reached epidemic proportions worldwide and contributes to premature mortality. Obesity is an abnormal or excessive fat accumulation and is defined by a body mass index  $\geq 30$  kg/m<sup>2</sup>. Obesity increases the risk for metabolic and cardiovascular diseases, musculoskeletal disorders, some types of cancer, pulmonary diseases, and psychological diseases. A doubling of the obesity prevalence since the 1980s may be caused by a globally increased intake of energy-dense foods with a parallel decrease in daily physical activity due to the increasingly sedentary nature of many forms of work, changing modes of transportation, and increasing urbanization. Obesity represents the strongest modifiable risk factor for type 2 diabetes (T2D). Obesity and T2D may develop on a common genetic risk background. Mechanisms linking obesity to T2D include abdominal fat distribution, adipose tissue dysfunction, and inflammation characterized by the secretion of a diabetogenic adipokine pattern which contributes to impaired insulin action in skeletal muscle, liver, brain, and other organs. In patients with obesity and T2D, therapeutic weight reduction leads to improvements of all metabolic disturbances including beneficial effects on insulin sensitivity, lipid metabolism, liver fat, and chronic inflammation. Weight loss could be achieved by caloric restriction combined with increased physical activity and behavior training in the context of multimodal interventions. Pharmacotherapies may support additional weight loss, and for patients with overweight- or obesity-associated T2D antihyperglycemic treatment strategies which promote weight loss should be preferred. However, bariatric surgery is the approach with the best long-term efficacy to treat morbid obesity and may lead to significant improvements on obesity comorbidities including a high remission rate of T2D.

---

**Keywords**

Obesity · Diabetes · Adipose tissue · Insulin resistance · Adipokines ·  $\beta$ -cell function · Fat distribution · Genetics · Weight loss · Diet · Pharmacotherapy · Bariatric surgery

---

**Introduction**

Obesity is characterized by an excess of body fat mass and is defined by a body mass index (BMI) equal to or greater than 30 kg/m<sup>2</sup>. Its prevalence has increased considerably over the past decades in all parts of the world and currently affects 15–30% of the adult populations in Western countries. This worldwide obesity epidemic has become a major health concern, because it contributes to higher mortality due to an increased risk for noncommunicable diseases including type 2 diabetes, cardiovascular diseases, musculoskeletal disorders, and some cancers including endometrial, breast, ovarian, prostate, liver, gallbladder, kidney,

and colon cancer. Obesity represents by far the most important modifiable risk factor for type 2 diabetes (T2D) mellitus. An abdominal type of body fat distribution is closely associated with type 2 diabetes, particularly in the lower body mass index categories. Insulin resistance may link accumulation of adipose tissue in obesity to type 2 diabetes although the underlying mechanisms are not completely understood.

The fundamental cause of obesity is an energy imbalance between calories consumed and calories expended. Both obesity and type 2 diabetes have a strong genetic background. The known susceptibility genes for obesity mainly affect central pathways of food intake, whereas most risk genes for type 2 diabetes compromise  $\beta$ -cell function. In addition, environmental factors contribute to obesity. Such factors include permanent availability of foods, energy-dense diets, lack of physical activity, and low socioeconomic status.

At least theoretically, obesity is largely preventable. Obesity could be reduced by supportive environments and communities shaping people's choices, by making the choice of healthier foods and regular physical activity the most accessible, available, and affordable choice. At the individual level, obesity could be prevented and treated by limiting energy intake from total fats and sugars; increasing consumption of fruit, vegetables and legumes, whole grains, and nuts; and engaging in regular physical activity (60 min a day for children and 150 min spread through the week for adults) (WHO).

Weight loss improves – in part as a function of the extent of reducing body weight and fat mass – all noncommunicable obesity-related diseases. Weight management including weight loss and maintaining a healthier body weight can be achieved by dietary therapy, physical activity, behavior modification, pharmacotherapy, and weight loss surgery. Surgical obesity treatment is the most powerful approach to treat morbid obesity and may lead to a marked improvement of the metabolic disturbances if not the resolution of type 2 diabetes.

---

## Definition of Obesity

Obesity is defined as abnormal or excessive fat accumulation that may impair health (National Institute for Health and Clinical Excellence 2014). Body mass index (BMI) is a simple index of weight-for-height that is commonly used to classify overweight and obesity in adults. It is defined as a person's weight in kilograms divided by the square of his height in meters ( $\text{kg}/\text{m}^2$ ). According to the World Health Organization (WHO) (WHO fact sheet 2016), a BMI greater than  $30 \text{ kg}/\text{m}^2$  is the central formal criterion for the definition of obesity (Table 1). For individuals with a BMI greater than  $30 \text{ kg}/\text{m}^2$ , obesity is further subdivided into three classes depending on the severity of excessive body fat (Table 1). The BMI range of  $25\text{--}29.9 \text{ kg}/\text{m}^2$  represents the category of overweight or preobesity which requires additional criteria to assess the concomitant health risks.

**Table 1** Classification of human obesity based on body mass index (BMI). (Reproduced from World Health Organization 2016)

Classification	BMI (kg/m <sup>2</sup> )
Underweight	<18.5
Normal weight	18.5–24.9
Overweight	25–29.9
Obesity	
Grade I	30–34.9
Grade II	35–39.9
Grade III	≥40

**Table 2** Diagnostic criteria for diabetes according to the American Diabetes Association (ADA 2015)

HbA1c ≥6.5%. The test should be performed in a laboratory using a method that is NGSP certified and standardized to the DCCT assay<sup>a</sup>

OR

FPG ≥126 mg/dL (7.0 mmol/L). Fasting is defined as no caloric intake for at least 8 h<sup>a</sup>

OR

2-h PG ≥200 mg/dL (11.1 mmol/L) during an OGTT. The test should be performed as described by the WHO, using a glucose load containing the equivalent of 75 g anhydrous glucose dissolved in water<sup>a</sup>

OR

In a patient with classic symptoms of hyperglycemia or hyperglycemic crisis, a random plasma glucose ≥200 mg/dL (11.1 mmol/L)

<sup>a</sup>In the absence of unequivocal hyperglycemia, results should be confirmed by repeat testing

## Definition and Classification of Diabetes

Diabetes may be diagnosed based on HbA1c criteria or plasma glucose criteria, either the fasting plasma glucose (FPG) or the 2-h plasma glucose (2-h PG) value after a 75-g oral glucose tolerance test (OGTT) (Table 2). Diabetes is a group of metabolic diseases characterized by hyperglycemia resulting from defects in insulin secretion, insulin action, or both (ADA 2015). The chronic hyperglycemia of diabetes is associated with long-term damage, dysfunction, and failure of different organs, especially the eyes, kidneys, nerves, heart, and blood vessels. Diabetes can be classified into four general categories (Table 3). Type 1 diabetes is caused by (autoimmune) β-cell destruction, usually leading to absolute insulin deficiency. Type 2 diabetes accounts for ~90–95% of diabetes cases and encompasses individuals who have insulin resistance combined with relative insulin deficiency (ADA 2010). Most likely, pathogenetic factors including obesity-associated diabetes are more heterogeneous. Another category of diabetes is gestational diabetes mellitus (GDM), which is diagnosed in the second or third trimester of pregnancy, but is not considered clearly overt diabetes. Under a fourth category, specific types of diabetes are summarized, which are due to other causes, e.g., monogenic diabetes

**Table 3** Etiologic classification of diabetes mellitus (ADA 2010)

<b>I. Type 1 diabetes</b> ( $\beta$ -cell destruction, usually leading to absolute insulin deficiency)
A. Immune mediated
B. Idiopathic
<b>II. Type 2 diabetes</b> (may range from predominantly insulin resistance with relative insulin deficiency to a predominantly secretory defect with insulin resistance)
<b>III. Other specific types</b>
A. Genetic defects of $\beta$ -cell function
1. Chromosome 12, HNF-1 $\alpha$ (MODY3)
2. Chromosome 7, glucokinase (MODY2)
3. Chromosome 20, HNF-4 $\alpha$ (MODY1)
4. Chromosome 13, insulin promoter factor-1 (IPF-1; MODY4)
5. Chromosome 17, HNF-1 $\beta$ (MODY5)
6. Chromosome 2, <i>NeuroDI</i> (MODY6)
7. Mitochondrial DNA
8. Others
B. Genetic defects in insulin action
1. Type A insulin resistance
2. Leprechaunism
3. Rabson-Mendenhall syndrome
4. Lipotrophic diabetes
5. Others
C. Diseases of the exocrine pancreas
1. Pancreatitis
2. Trauma/pancreatectomy
3. Neoplasia
4. Cystic fibrosis
5. Hemochromatosis
6. Fibrocalculous pancreatopathy
7. Others
D. Endocrinopathies
1. Acromegaly
2. Cushing's syndrome
3. Glucagonoma
4. Pheochromocytoma
5. Hyperthyroidism
6. Somatostatinoma
7. Aldosteronoma
8. Others
E. Drug or chemical induced
1. Vacor
2. Pentamidine
3. Nicotinic acid
4. Glucocorticoids
5. Thyroid hormone
6. Diazoxide
7. $\beta$ -adrenergic agonists
8. Thiazides
9. Dilantin

(continued)

**Table 3** (continued)

10. $\gamma$ -Interferon
11. Others
<b>F. Infections</b>
1. Congenital rubella
2. Cytomegalovirus
3. Others
<b>G. Uncommon forms of immune-mediated diabetes</b>
1. “Stiff-man” syndrome
2. Anti-insulin receptor antibodies
3. Others
<b>H. Other genetic syndromes sometimes associated with diabetes</b>
1. Down syndrome
2. Klinefelter syndrome
3. Turner syndrome
4. Wolfram syndrome
5. Friedreich ataxia
6. Huntington chorea
7. Laurence-Moon-Biedl syndrome
8. Myotonic dystrophy
9. Porphyria
10. Prader-Willi syndrome
11. Others
<b>IV. Gestational diabetes mellitus</b>

syndromes, including neonatal diabetes and maturity-onset diabetes of the young (MODY), diseases of the exocrine pancreas, and drug- or chemical-induced diabetes (Table 3).

## Epidemiology of Obesity and Diabetes

Obesity has reached epidemic proportions globally with a prevalence which has more than doubled since 1980. According to the WHO, more than 1.9 billion adults were overweight and of these, over 600 million were obese (WHO 2016) in 2014. Overall, about 13% of the world’s adult population (11% of men and 15% of women) were obese in 2014. Overweight and obesity are linked to more deaths worldwide than underweight. Globally there are more people who are obese than underweight – this occurs in every region except parts of sub-Saharan Africa and Asia. Forty-one million children under the age of 5 were overweight or obese in 2014. Once considered a high-income country problem, obesity prevalence is now increasing in low- and middle-income countries, particularly in urban settings. In Africa, the number of children who are overweight or obese has nearly doubled from 5.4 million in 1990 to 10.6 million in 2014 (WHO). In the context of the Global Burden of Disease Study (GBD) (Ng et al. 2014), estimates of the prevalence of

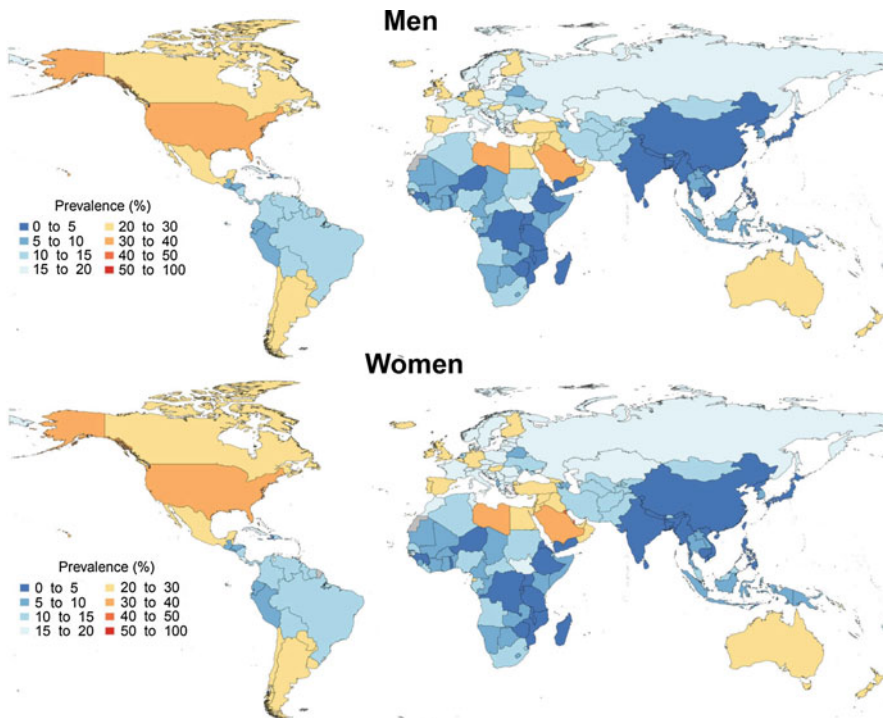

**Fig. 1** Age-standardized prevalence of obesity (BMI  $\geq 30$  kg/m<sup>2</sup>), age >20 years in men and women 2013. (Taken from GBD 2013 Mortality and Causes of Death Collaborators 2015)

overweight and obesity were reported for men and women in different age groups separately from 188 countries and 21 regions (Fig. 1).

From 1980 to 2013, combined prevalence of overweight and obesity increased by 27.5% (from 921 million to 2.1 billion) for adults and by 47.1% for children (Ng et al. 2014). This trend in age-standardized global obesity prevalence was observed in developing and developed countries (Fig. 1; Ng et al. 2014). The proportion of adults with a BMI of  $\geq 25$  kg/m<sup>2</sup> increased from 28.8% (28.4–29.3) in 1980 to 36.9% (36.3–37.4) in 2013 for men and from 29.8% (29.3–30.2) to 38.0% (37.5–38.5) for women (Ng et al. 2014). In developed countries, men have higher rates of obesity, while in developing countries, women exhibit higher rates and this relationship persists over time. The rate of increase of obesity was most pronounced between 1992 and 2002, but has slowed down over the last decade, particularly in developed countries (Ng et al. 2014).

In parallel to the significant increase in obesity prevalence since 1980, age-standardized diabetes prevalence in adults has almost quadrupled with a faster increase in low/middle-income compared to high-income countries (Zhou et al. 2016). In the NCD Risk Factor Collaboration, data from 751 studies including more than 4 million adults from 146 countries were used to estimate global age-standardized diabetes



**Table 4** Estimated prevalence of people with diabetes (age >18 years). (Modified from NCD Risk Factor Collaboration. Worldwide diabetes prevalence data from 1980 and 2014 from a pooled analysis of 751 population-based studies with more than 4 million participants. Modified from Zhou et al. 2016)

WHO region	Prevalence (%)		Number (millions)	
	1980	2014	1980	2014
<b>Africa</b>				
<b>The Americas</b>	3.1	7.1	4	25
<b>Eastern Mediterranean</b>	5	8.3	18	63
<b>Europe</b>	5.3	7.3	33	64
<b>South-East Asia</b>	4.1	8.6	17	96
<b>Western Pacific</b>	4.4	8.4	29	131
<b>Total</b>	<b>4.7</b>	<b>8.5</b>	<b>108</b>	<b>422</b>

prevalence, which increased from 4.3% in 1980 to 9.0% in 2014 in men and from 5.0% to 7.9% in women (Zhou et al. 2016). The number of adults with diabetes in the world increased from 108 million in 1980 to 422 million in 2014 (Table 2). Age-standardized adult diabetes prevalence in 2014 was lowest in northwestern Europe and highest in Polynesia and Micronesia, at nearly 25%, followed by Melanesia and the Middle East and North Africa (Table 4).

---

## Pathophysiology of Obesity and Diabetes

The fundamental cause of obesity is an energy imbalance between calories consumed and calories expended. Globally, there has been an increased intake of energy-dense foods that are high in fat and a decrease in physical activity due to the modern sedentary nature of many forms of work, changing modes of transportation, and increasing urbanization (WHO 2016). In addition, genetic factors may underlie heterogeneous susceptibility for the extent of weight gain upon overeating, physical inactivity, and our adipogenic environment (Hauer 2010).

Changes in dietary and physical activity patterns are often the result of environmental and societal changes associated with development and lack of supportive policies in sectors such as health, agriculture, transport, urban planning, environment, food processing, distribution, marketing, communication, and education (Swinburn et al. 2011). Most likely a complex gene–environment interaction determines the individual risk to develop obesity.

In humans, energy homeostasis is under tight control and a stable body weight is very well defended across challenges including times of hunger and overeating. The tight defense of body weight (loss) suggests the existence of a setpoint for body weight, which can vary substantially among individuals and may also vary across lifetime (Hauer 2010). Appetite and satiety are regulated by a complex system which controls energy homeostasis. This system integrates central pathways and signals from peripheral organs (e.g., leptin from adipose tissue, gut hormone secretion in response to meals, signals from the gastrointestinal nervous system, nutrients).

These signals induce a complex response in the central nervous system specifically in the anorexigenic leptin–melanocortin and the orexigenic NPY–AgRP pathways according to dietary intake and nutrient requirements of the organism (Hauner 2010). Other factors such as insulin may modify these signaling processes and thereby influence energy balance (Schwartz et al. 2000). A complex homeostatic system serves to defend body weight against critical energy deficits or chronic overnutrition. Several adaptive systems are known to restore the initial body weight under such fluctuations of energy intake and expenditure. This may explain why obese humans exhibit a strong tendency to regain weight after intentional dietary weight reduction. The same tendency to return to initial body weight is observed after experimental overfeeding. The role of energy homeostasis in the development of obesity has been elaborated by previous studies using indirect calorimetry to investigate the contribution of the resting metabolic rate to the risk of obesity. Importantly, reduced resting energy expenditure predicts body weight gain in Pima Indians (Ravussin et al. 1988).

Environmental factors that may contribute to both the development of obesity and type 2 diabetes include almost unlimited availability and high palatability of food, high energy density and relatively low cost of foods, high consumption of sugar-sweetened beverages, aggressive commercial food promotion, culture of fast food, and low physical activity (Hauner 2010). Importantly, the socioeconomic status is a strong determinant of obesity and of T2D. In most countries, there is a gradient between education and household income and the prevalence of obesity. A low socioeconomic status is associated with an unfavorable lifestyle including poor nutrition, low leisure-time physical activity, and low health consciousness. Thus, the association between low household income and obesity may be mediated by the low costs of energy-dense foods, whereas prudent healthy diets based on lean meats, fish, vegetables, and fruit may be less affordable for those of lower socioeconomic status (Hauner 2010). The enormous complexity of the causal relations and determinants of obesity (Fig. 2) and their interrelations may explain why strategies to prevent or treat obesity have widely failed. In addition, the mechanisms causing obesity are not understood well enough to offer an effective prevention and etiology-based individualized treatment.

In the context of the relationship between obesity and impaired glucose metabolism, this chapter focuses on type 2 diabetes. T2D is characterized by an impaired insulin action or a defective secretion of insulin or a combination of both (Fig. 3). Both defects are thought to be required for the manifestation of the disease, and both are present many years before the clinical onset of the disease. Whereas insulin resistance is an early phenomenon partly related to obesity, pancreas  $\beta$ -cell function declines gradually over time already before the onset of clinical hyperglycemia (Stumvoll et al. 2005). In the pathogenesis of T2D, several mechanisms have been proposed, including increased nonesterified fatty acids, inflammatory cytokines, adipokines, and mitochondrial dysfunction for insulin resistance and glucotoxicity, lipotoxicity, and amyloid formation for  $\beta$ -cell dysfunction. To understand the cellular and molecular mechanisms causing T2D, it is necessary to conceptualize the framework within which glycemia is controlled. Insulin is the key hormone for regulating blood glucose

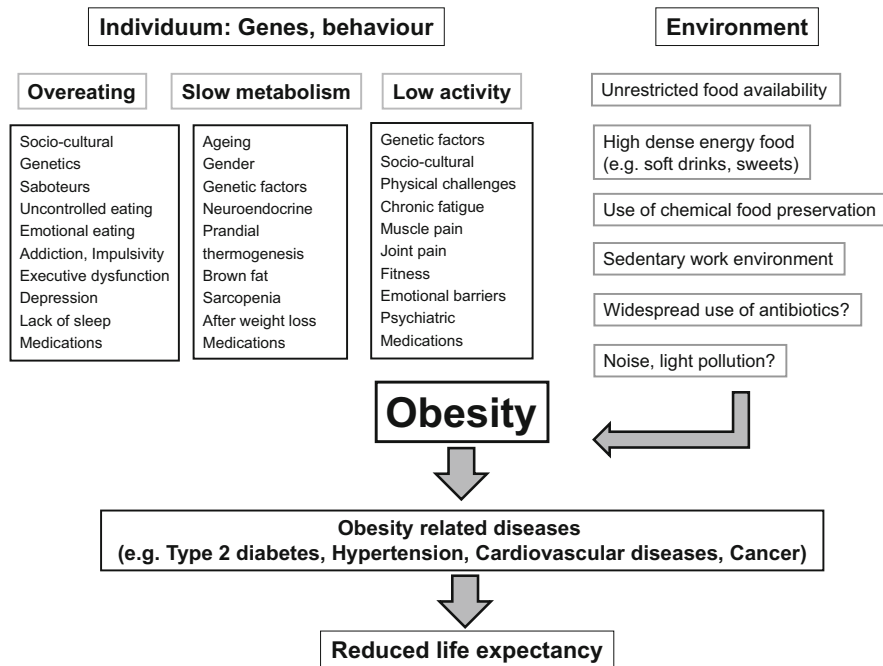

**Fig. 2 Pathogenesis of obesity.** Obesity is caused by a chronic positive energy balance characterized by overeating, low energy expenditure, and low physical activity. The complex individual, sociocultural, and environmental pathogenic factors are not understood well enough to offer an etiology-based obesity treatment. Changes in dietary and physical activity patterns are often the result of environmental and societal changes associated with development and lack of supportive policies in sectors such as health, agriculture, transport, urban planning, environment, food processing, distribution, marketing, communication, and education. As a consequence of obesity, the risk of metabolic and vascular diseases such as type 2 diabetes, fatty liver disease, hypertension, coronary heart disease, and peripheral artery disease, but also pulmonary diseases, osteoarthritis, psychological disorders, and several types of cancer increases

**Fig. 3 Hyperbolic relation between  $\beta$ -cell function and insulin sensitivity.** *IGT* impaired glucose tolerance, *NGT* normal glucose tolerance, *T2DM* type 2 diabetes mellitus. (Reproduced from Stumvoll et al. 2005)

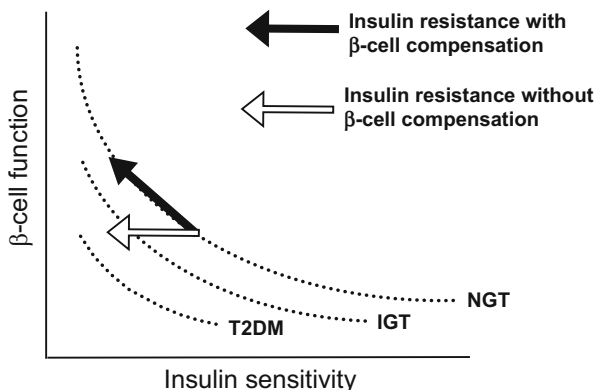

and, generally, normoglycemia is maintained by the balanced interplay between insulin action and insulin secretion. It is important to note that the normal pancreatic cell is capable of adapting to changes in insulin action, i.e., a decrease in insulin action is accompanied by upregulation of insulin secretion (and vice versa), and there is a curvilinear relationship between normal  $\beta$ -cell function and insulin sensitivity (Stumvoll et al. 2005) (Fig. 3). Deviation from this “hyperbola” such as in individuals with impaired glucose tolerance (IGT) and T2D occurs when  $\beta$ -cell function is inadequately low for a given degree on insulin sensitivity (Fig. 3). Thus,  $\beta$ -cell dysfunction is a critical component in the pathogenesis of type 2 diabetes. This concept has been verified by longitudinal studies in Pima Indians progressing from normal to impaired glucose tolerance to type 2 diabetes (Stumvoll et al. 2005). On the other hand, when insulin action decreases such as in response to weight gain, the system normally compensates by increasing  $\beta$ -cell function. However, at the same time, fasting and 2-h glucose concentrations will increase significantly. This increase may well be small but over time and due to glucose toxicity becomes damaging and in itself a cause for  $\beta$ -cell dysfunction. Thus, even with (theoretically) unlimited  $\beta$ -cell reserve insulin resistance sets the path to hyperglycemia and type 2 diabetes (Stumvoll et al. 2005). Importantly, the capacity of the organism to compensate for various challenges on glucose homeostasis may have a strong genetic component; however only a few “T2D-genes” have been identified so far.

---

## Genetics of Obesity and Diabetes

Family, adoption, and twin studies have provided strong evidence that obesity and T2D are heritable traits (Hauner 2010; Franks and McCarthy 2016). As an example, an adoption study demonstrated that there was no resemblance between the adult BMI of adopted Danish children and the BMI of the adopting parents, but a significant correlation to the BMI of the biologic parents, especially to the BMI class of the biologic mother (Stunkard et al. 1986b). In a twin study of obesity, concordance rates for different degrees of overweight were twice as high for monozygotic twins as for dizygotic twins. This high heritability for BMI was seen at the age of 20 years and to a similar extent at a 25-year follow-up, suggesting that body fatness is under substantial genetic control (Stunkard et al. 1986a). There is also a very close correlation in monozygotic twins who were reared apart, also indicating a high heritability of the BMI trait. In a systematic study among 5092 twins investigated in the UK, the estimated heritability of BMI and waist circumference was 0.77, further supporting the strong effect of the genetic components irrespective of the environment (Wardle et al. 2008).

Our understanding of the genetic causes of obesity has been improved during recent years by discoveries of monogenic disorders that result in excessive fat accumulation. Although monogenic obesity only occurs in very rare cases, characterization of the causative variants led to novel concepts in the pathophysiology and potentially the future treatment of obesity.

Monogenic obesity is typically diagnosed in childhood as early onset obesity due to extreme alterations of appetite and satiety. Following the discovery that a lack of the adipose tissue hormone leptin causes the extremely obese phenotype of the *ob/ob* mouse model (Zhang et al. 1994), rare cases of monogenetically inherited leptin deficiency have been also found in humans (Farooqi et al. 1999). Importantly, for individuals with a loss-of-function mutation in the leptin gene, a truly etiology-based obesity treatment is available through compassionate use of recombinant leptin (Farooqi et al. 1999). As another example, patients with rare defects in the gene encoding proopiomelanocortin (POMC) have extreme early-onset obesity, hyperphagia, hypopigmentation, and hypocortisolism, resulting from the lack of the proopiomelanocortin-derived peptides melanocyte-stimulating hormone and corticotropin (Kühnen et al. 2016). In these individuals, treatment with the melanocortin-4 receptor agonist setmelanotide leads to sustainable reduction in hunger and substantial weight loss (Kühnen et al. 2016). Until now, several homozygous and compound heterozygous mutations have been described in genes that are involved in the central control of food intake, some of them with functional consequences resulting in human obesity (Franks and McCarthy 2016). Functional mutations in the melanocortin-4 receptor gene are considered to be the most frequent cause of monogenic obesity in children with a frequency of 2–4% of all obese cases (Hauner 2010).

Supporting the hypothesis that central mechanisms of food intake regulation are the main pathogenetic factors in obesity development and that obesity represents a heritable neurobehavioral disorder that is highly sensitive to environmental conditions, genome-wide association studies (GWAS) in large cohorts reported common genetic variants associated with BMI mainly related to central pathways of food intake (Frayling et al. 2007). Despite these remarkable advances in our understanding of the genetic factors related to obesity, the effect size of most of the BMI-related gene variants is rather modest. For example, homozygous carriers of the obesity-related variant with the strongest effect size in the FTO gene identified in GWAS have only 3 kg higher body weight compared to carriers of the two low-risk alleles (Frayling et al. 2007). Importantly, FTO is mainly expressed in the brain and in the arcuate nucleus of the hypothalamus and may thus play a role in regulation of food intake (Hauner 2010). All other recently discovered gene polymorphisms, including variants in the MC4R gene, influence body weight by far less than 1 kg (Hauner 2010). Thus, obesity represents a rather heterogeneous disorder in terms of genetic background and susceptibility to etiologic environmental factors. In addition, the risk for developing comorbidities including T2D may strongly depend on the individual genetic predisposition towards such diseases. In the case of T2D, the lifetime risk of developing this disease is about 30% in the white North American population and similar in other ethnic groups (Narayan et al. 2003). Importantly, the genetic risk for T2D may additionally be determined by genetic factors related to  $\beta$ -cell function (Scott et al. 2017) and the interaction between genes and macronutrient intake (Li et al. 2017).

In the search for genetic risk factors for the development of T2D, the candidate gene approach, i.e., identifying a causative factor among the obvious biological candidates for insulin resistance and insulin secretion defects, has not provided significant advances to the field (Stumvoll et al. 2005). Variants in many candidate genes were extensively studied over the past 2 decades, such as the Gly972Arg polymorphism in IRS-1, the Gly1057Asp polymorphism in IRS-2, the Trp64Arg polymorphism in the beta-3 adrenergic receptor, the -308 G/A promoter variant in tumor necrosis factor- $\alpha$  (TNF- $\alpha$ ) or variants in the adiponectin gene. In most instances, the initial association was not replicated in subsequent analyses and, currently, the most robust single candidate variant is the highly prevalent Pro12Ala polymorphism in peroxisome proliferator-activated receptor (PPAR) $\gamma$  (reviewed in Stumvoll et al. 2005). The Gly972Arg polymorphism in IRS-1, an intuitive variant to be associated with insulin resistance, may have a weak association with type 2 diabetes, although possibly through  $\beta$ -cell dysfunction rather than insulin resistance (Porzio et al. 1999). Among the many candidate genes for insulin secretory dysfunction, those encoding the sulphonylurea receptor-1 (SUR1) and the potassium inward rectifier (KIR) 6.2, a potassium channel, have been most extensively studied. The two genes (ABCC8 and KCNJ11, respectively) are adjacent to one another on chromosome 11. There is insufficient evidence for association of two widely studied SUR1 polymorphisms (exon 16-3t/c, exon 18 T759T) with type 2 diabetes (Gloyn et al. 2003). Meta-analyses on the E23K variant in the KIR6.2 gene are more robust, suggesting an ~15% increased risk of type 2 diabetes for the K allele (Gloyn et al. 2003) most likely through decreased insulin secretion. A recent haplotype analysis using an independent dataset not only confirmed the association with the KIR6.2 variant but further substantiated the notion that genetic variation in the SUR1/KIR6.2 region is associated with type 2 diabetes.

Interestingly, analyses from the European Prospective Investigation into Cancer (EPIC) study show significant interactions between macronutrients and genetic variants in or near transcription factor 7-like 2 (TCF7L2), gastric inhibitory polypeptide receptor (GIPR), caveolin 2 (CAV2), and peptidase D (PEPD) have been described (Li et al. 2017). For the majority of the newly identified obesity and T2D genes, the main challenge remains to elicit their function and main targets. Understanding the mode of action for these candidate genes may facilitate their future clinical use as pharmacotherapies, drug targets, or predictors of obesity and T2D.

---

## Obesity: A Major Risk Factor for Type 2 Diabetes

The mechanisms by which obesity increases the risk of developing T2D are only partly understood and the evolving picture is getting more and more complex. The main adverse effect of obesity is on the action of insulin, particularly in liver, muscle, and adipose tissue, but obesity also affects insulin secretion. Substantial advances have been made over recent years in our understanding of how an excessive fat mass, but also chronic overnutrition, may cause metabolic disturbances resulting in overt T2D in those with a genetic predisposition for the disease.

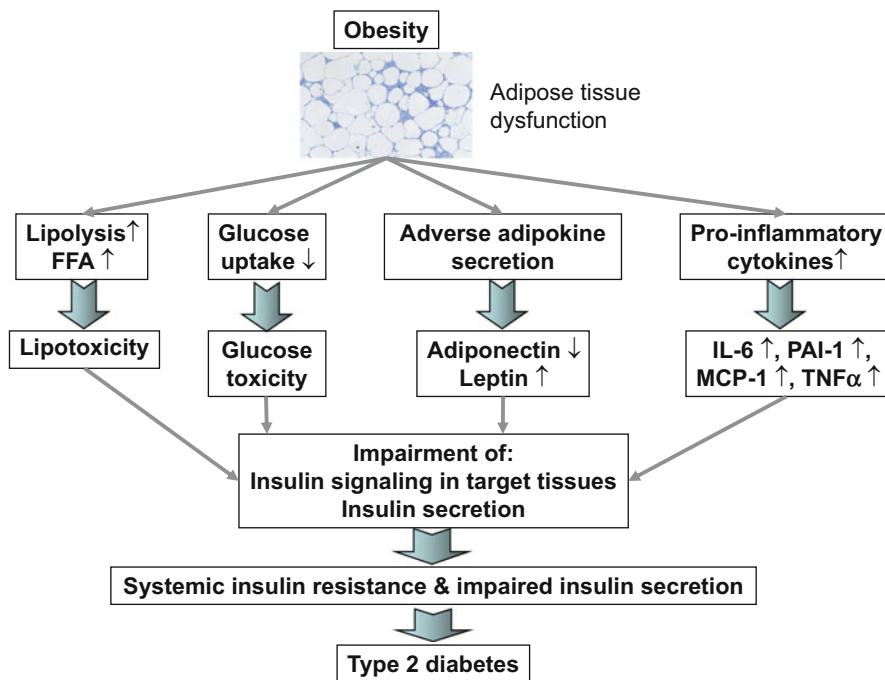

**Fig. 4** Model of factors linking obesity (including adipose tissue dysfunction), systemic insulin resistance, and impaired insulin secretion as potential mechanisms of how obesity increases the risk for type 2 diabetes. Several mechanisms including increased lipolysis, higher free fatty acid (FFA) release from adipose tissue, reduced glucose uptake, and the increased secretion of diabetogenic, atherogenic, and pro-inflammatory signals may cause impaired insulin sensitivity. Altered adipokine (e.g., adiponectin, leptin, chemerin, progranulin) and pro-inflammatory cytokine (e.g., IL-6, TNF- $\alpha$ , MCP-1, PAI-1) secretion from adipose tissue may directly impair insulin signaling (e.g., liver, skeletal muscle) or activate pro-inflammatory pathways in target tissues which causes local and subsequently systemic insulin resistance. *IL* interleukin, *TNF- $\alpha$*  tumor necrosis factor- $\alpha$ , *MCP-1* monocyte-chemotactic-protein-1, *PAI-1* plasminogen activator inhibitor-1. (Modified from Blüher 2016)

There are several mechanisms mediating the link and interaction between obesity and T2D (Fig. 4). Obesity (i.e., excessive fat accumulation), adverse fat distribution, and impaired adipose tissue function may cause impaired insulin signaling and insulin secretion defects via increased nonesterified (free) fatty acids (NEFA) from lipolysis, glucose toxicity in response to reduced peripheral glucose uptake and secretion of adipokines (e.g., leptin, adiponectin), and pro-inflammatory cytokines (e.g., IL-6, TNF- $\alpha$ , MCP-1) (Fig. 4). As an example, increased mass, especially in visceral or deep subcutaneous adipose depots, leads to adipocyte hypertrophy which are themselves resistant to the ability of insulin to suppress lipolysis. This results in elevated release and circulating levels of NEFA and glycerol, both of which aggravate insulin resistance in skeletal muscle and liver (Stumvoll et al. 2005).

## Role of Glucose Toxicity

Because hyperglycemia itself can decrease insulin secretion, the concept of glucose toxicity has been developed and may represent a mechanistic link between obesity and T2D (Fig. 4). Glucose toxicity may initially cause reversible, but in the context of chronic hyperglycemia sustained, damage to cellular components of insulin production over time (Stumvoll et al. 2005; DeFronzo 2010). Even short-term hyperglycemia induced by prolonged hyperglycemic clamp studies in individuals with normal glucose metabolism causes significant deterioration of insulin sensitivity and insulin secretion (Brunzell et al. 1976). In  $\beta$ -cells, oxidative glucose metabolism will lead to production of reactive oxygen species (ROS), normally detoxified by catalase and superoxide dismutase.  $\beta$ -cells are equipped with a low amount of these proteins and also of the redox-regulating enzyme glutathione peroxidase (Robertson et al. 2003). Hyperglycemia has been proposed to lead to large amounts of ROS in  $\beta$ -cells, with subsequent damage to cellular components. Loss of pancreas duodenum homeobox-1 (PDX-1), a critical regulator of insulin promoter activity, has also been proposed as an important mechanism leading to  $\beta$ -cell dysfunction (Robertson et al. 2003). In addition, ROS are known to enhance nuclear factor kappa-light-chain enhancer of activated B cells (NF- $\kappa$ B) activity, which may induce apoptosis of  $\beta$ -cells.

---

## Role of Lipotoxicity

Increased levels of non-esterified fatty acids (NEFA) released by expanded (predominantly visceral) adipose tissue adversely influence the insulin signaling cascade (Stumvoll et al. 2005). NEFA inhibit insulin-stimulated glucose metabolism in skeletal muscle and suppress glycogenolysis in liver (Boden and Shulman 2002). Fatty acids lead to enhanced insulin secretion in acute studies, but after 24 h they actually inhibit insulin secretion. In the presence of glucose, fatty acid oxidation in  $\beta$ -cells is inhibited and accumulation of long-chain acyl CoA (LC-CoA) occurs (Stumvoll et al. 2005). This has been proposed to be an integral part of the normal insulin secretory process. However, long-chain acyl CoA itself can also diminish the insulin secretory process by opening  $\beta$ -cell potassium channels. A second mechanism possibly involved in the negative effect of fatty acids on insulin secretion may be increased expression of uncoupling protein-2 (UCP-2), which would lead to less ATP formation and, hence, less insulin secretion. A third mechanism may involve apoptosis of  $\beta$ -cells possibly via fatty acid or triglyceride-induced ceramide synthesis or generation of reactive oxygen species and/or nitric oxide (Stumvoll et al. 2005). NEFA activate cellular kinases, including atypical protein kinase C isoforms by increasing cellular diacylglycerol levels, which can activate the inflammatory kinases inhibitor  $\kappa$ B kinase (IKK) and c-jun N-terminal kinase (JNK), increasing serine/threonine phosphorylation of IRS-1 and reducing downstream IRS-1 signaling (Stumvoll et al. 2005; Boden and Shulman 2002). Adipose tissue-secreted cytokines including TNF- $\alpha$  enhance adipocyte lipolysis



and contribute further to increased NEFA plasma concentrations, which may subsequently deteriorate  $\beta$ -cell function and glucose-stimulated insulin secretion (Stumvoll et al. 2005; Blüher 2013). Experimental NEFA elevation to reproduce levels in type 2 diabetes causes severe muscle/liver insulin resistance and inhibits insulin secretion (reviewed in: DeFronzo 2010). Elevated plasma NEFA impair glucose oxidation/glycogen synthesis and decrease glucose transport/phosphorylation (reviewed in: DeFronzo 2010). Most importantly, lipid infusion to increase plasma NEFA levels in participants with normal glucose tolerance caused a dose–response inhibition of insulin receptor/IRS-1 tyrosine phosphorylation and PI-kinase activity, which correlate closely with reduced insulin-stimulated glucose disposal (Belfort et al. 2005).

---

## Role of Insulin Resistance

Insulin resistance is defined as the inability of a known quantity of exogenous or endogenous insulin to increase glucose uptake and utilization in an individual as much as it does in a normal population (Lebovitz 2001). Insulin action is the consequence of insulin binding and activation of its specific plasma membrane receptor with tyrosine kinase activity and is transmitted through the cell by a series of protein-protein interactions. Two major cascades of protein-protein interactions mediate intracellular insulin action: one pathway is involved in regulating intermediary metabolism and the other plays a role in controlling growth processes and mitoses (Lebovitz 2001). The regulation of these two distinct pathways can be dissociated. Indeed, some data suggest that the pathway regulating intermediary metabolism is diminished in type 2 diabetes while that regulating growth processes and mitoses is normal. Genetic abnormalities of one or more proteins of the insulin action cascade, fetal malnutrition, adipose tissue dysfunction, and increased visceral adiposity have been suggested as major causes of insulin resistance (Lebovitz 2001; DeFronzo 2010). In the fasting state, skeletal muscle accounts for only a small proportion of glucose disposal (less than 20%), while endogenous glucose production from the liver is responsible for all of the glucose appearing in plasma (Stumvoll et al. 2005).

Cellular mechanisms of insulin resistance may contribute to tissue-related and systemic insulin resistance. Substrates of the insulin receptor kinase, most prominently the insulin receptor substrate (IRS) proteins, are phosphorylated on multiple sites, which serve as binding scaffolds for a variety of adaptor proteins and lead to the downstream signaling cascade (White 2002). Insulin activates a series of lipid and protein kinase enzymes linked to the translocation of glucose transporters to the cell surface, synthesis of glycogen, protein, mRNAs, and nuclear DNA that influence cell survival and proliferation (White 2002). In states of insulin resistance, one or more of the following molecular mechanisms to block insulin signaling are likely to be involved. The positive effects on downstream responses exerted by tyrosine phosphorylation of

the receptor and the IRS proteins are opposed by dephosphorylation of these tyrosine side-chains by cellular protein-tyrosine phosphatases (PTPs) and by protein phosphorylation on serine and threonine residues (which often occur together) (Goldstein 2003). PTP1B is a widely expressed PTP which has been shown to play an important role in the negative regulation of insulin signaling (Goldstein 2003).

Serine/threonine phosphorylation of IRS-1 reduces its ability to act as a substrate for the tyrosine kinase activity of the insulin receptor and inhibits its coupling to its major downstream effector systems. Multiple IRS serine kinases have been identified, including various mitogen-activated protein kinases (MAPK/ERK), c-Jun NH<sub>2</sub>-terminal kinase (JNK), atypical protein kinase C, phosphatidylinositol 3'-kinase, among others (White 2002). Signal down-regulation can also occur via internalization and loss of the insulin receptor from the cell surface and degradation of IRS proteins (Stumvoll et al. 2005).

---

## Body Fat Distribution and Risk for Type 2 Diabetes

Approximately 70% of individuals with obesity do not develop T2D, suggesting that fat accumulation alone does not explain the higher risk of T2D upon body weight gain. In this context, it has been consistently demonstrated that fat distribution rather than total body fat mass determines the individual obesity-associated risk for T2D (Schleinitz et al. 2014; Bjorntorp 1991). Fat stored in visceral adipose depots makes obese individuals more prone to T2D than fat distributed subcutaneously (Despres et al. 1989). Moreover, it has been demonstrated that reducing subcutaneous fat mass by liposuction does not ameliorate risk factors of T2D and cardiovascular diseases (Klein et al. 2004). On the other hand, visceral fat mass reduction by omentectomy combined with gastric banding resulted in long-term beneficial effects on glucose metabolism and insulin sensitivity (Thorne et al. 2002). The relationship of ectopic visceral fat deposition with T2D may be at least partially explained by intrinsic properties of visceral as opposed to subcutaneous adipose tissue with regard to decreased insulin sensitivity, lower angiogenic potential, increased lipolytic activity, different cellular composition, and the expression of genes regulating adipocyte function (Blüher 2009). In addition, the visceral fat depot drains into the portal vein, thus exposing the liver to undiluted metabolites, cytokines, and adipokines released from visceral fat, which could further contribute to an increased cardiometabolic risk (Schleinitz et al. 2014). Dysfunction of adipose tissue including ectopic fat deposition seems to play an important role in the individual risk of developing obesity-associated T2D. However, it is noteworthy that recent imaging studies, including the Framingham Heart Study, have highlighted not only the importance of visceral adipose tissue but also other ectopic fat depots such as liver or renal fat (Speliotes et al. 2010; Foster et al. 2011).

## Role of Adipose Tissue Dysfunction: A Mechanistic Link Between Obesity and Type 2 Diabetes

Adipose tissue represents the major organ for energy storage under conditions of caloric surplus. During periods of fasting and prolonged starvation, adipose tissue releases lipids to serve the energy demand of the body. In addition, adipose tissue contributes to insulation of the body, thermoregulation, and mechanical organ protection (Blüher 2013). With higher adipose tissue mass and fat accumulation, the risk to develop insulin resistance and type 2 diabetes increases (Colditz et al. 1995). On the other hand, deficiency or a complete lack of adipose tissue also causes insulin resistance, diabetes, fatty liver, and other metabolic alterations both in transgenic animals and in human lipodystrophies (Moitra et al. 1998; Robbins and Savage 2015). The association of lipodystrophy with metabolic diseases suggests that impaired lipid storage capacity of adipose tissue may underlie the link to insulin resistance and metabolic diseases, a hypothesis which is further supported by adipose tissue transplantation experiments in animal models demonstrating that increasing functional adipose tissue mass may have beneficial effects on glucose and lipid metabolism (Konrad et al. 2007; Tran et al. 2008).

Typically, there is a curvilinear relationship between insulin sensitivity and BMI (Fig. 5). With increasing BMI, insulin sensitivity decreases; however, there are subgroups of individuals with an either inadequately high insulin sensitivity despite BMI  $>40$  kg/m<sup>2</sup> which have been described as insulin-sensitive patients with obesity (Klötting et al. 2010) or patients with lipodystrophy who are characterized by extreme insulin resistance at a BMI  $<25$  kg/m<sup>2</sup> (Fig. 5). Some of these phenotype characteristics of both excessive and lack of adipose tissue could be explained by altered adipocyte storage capacity, i.e., impaired expandability of subcutaneous adipose tissue; the release of diabetogenic metabolites, cytokines, or adipokines; or impaired lipogenesis and lipolysis (Blüher 2009).

These complex alterations of adipose tissue function may develop under conditions of a chronically positive energy balance due to continued overeating and low physical activity. Under these circumstances which describe the modern lifestyle in many parts of the world, adipose tissue mass increases (Fig. 6). Whereas a subgroup of individuals may respond to caloric access by expanding “healthy” subcutaneous fat depots through adipocyte hyperplasia and hypertrophy, the majority of patients with obesity exhibit an impaired expandability of subcutaneous adipose tissue. This inability to store energy in safe places may initiate a sequence of pathogenic factors including adipocyte hypertrophy, ectopic fat deposition (liver, visceral fat, skeletal muscle), hypoxia, adipocyte insulin resistance, increased stress response, autophagy, and apoptosis causing impaired adipose tissue function which subsequently leads to end organ damage through adverse signals from adipose tissue (Fig. 6) (Blüher 2009).

With the discovery that adipose tissue produces and secretes hundreds of factors (e.g., leptin, adiponectin, TNF- $\alpha$ , sex steroids, adipsin) (Table 5, Fig. 7), it became clear that altered adipose tissue function could cause secondary changes in target

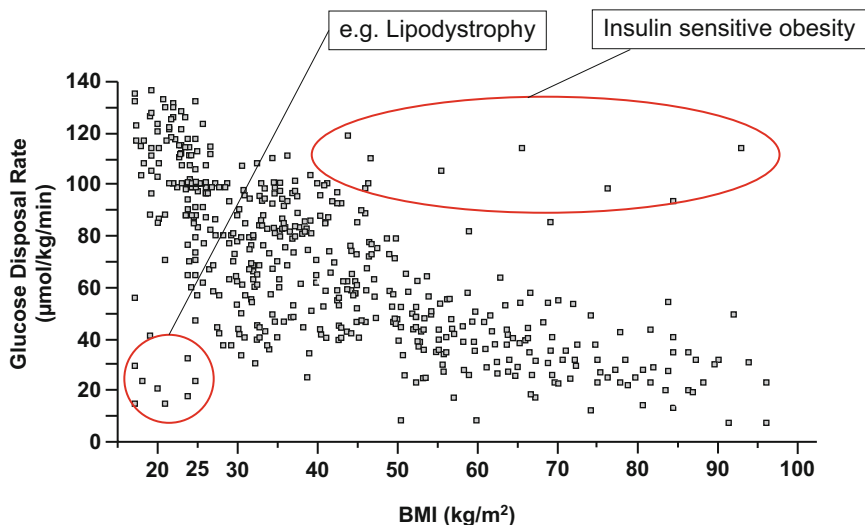

**Fig. 5 Relationship between insulin sensitivity and BMI in individuals with a wide range of insulin sensitivity and BMI.** Despite the hyperbolic relationship between decreasing insulin sensitivity and increasing BMI, there are individuals with low BMI, but pronounced insulin resistance (e.g., lipodystrophy), or with BMI  $>40$   $\text{kg}/\text{m}^2$ , but insulin sensitivity similar to a person with a BMI  $<25$   $\text{kg}/\text{m}^2$ . The dotted hyperbolic line is a regression curve of glucose infusion rate (GIR) during the steady state of a euglycemic-hyperinsulinemic clamp over BMI based on subjects at the University Hospital Leipzig outpatients clinics who underwent euglycemic clamps between 1996 and 2005. (Modified from Klötting et al. 2010)

organs of these adipokines (reviewed in Blüher 2016). Distinct cell types within adipose tissue produce pro-inflammatory cytokines/adipokines including TNF- $\alpha$ , transforming growth factor  $\beta$  (TGF $\beta$ ) and interferon- $\gamma$ , C-reactive protein (CRP), interleukins (IL)-1, -6, -8, -10, plasminogen activator inhibitor-1 (PAI-1), retinol-binding protein-4 (RBP4), vaspin, endocannabinoids, fetuin-A, omentin, bone morphogenetic proteins (BMPs), clusterin, fractalkine, orosomucoid, fatty acid binding protein 4 (FABP4), fibrinogen, haptoglobin, angiotensin-related proteins, metallothionein, complement factor 3, serum amyloid A (SAA) protein, anandamide, and 2-AG as well as chemoattractant cytokines, such as monocyte chemoattractant protein-1 (MCP-1), progranulin, and macrophage inflammatory protein-1 $\alpha$  and others (Fig. 7, Table 5) (Blüher 2013). The majority of these adipokines are elevated in obese states and correlate with measures of fat mass, fat distribution, and insulin sensitivity.

Adipose tissue released factors contribute to the regulation of multiple important biological processes including the regulation of appetite and satiety control, fat distribution, insulin sensitivity and insulin secretion, energy expenditure, inflammation, blood pressure, hemostasis, and endothelial function, modulation of adipogenesis, immune cell migration into adipose tissue, and adipocyte metabolism and function in an autocrine, paracrine manner as well as in an endocrine manner on target organs including the brain, liver, muscle, endothelium, heart, skin, and pancreatic  $\beta$ -cells (Fig. 8).

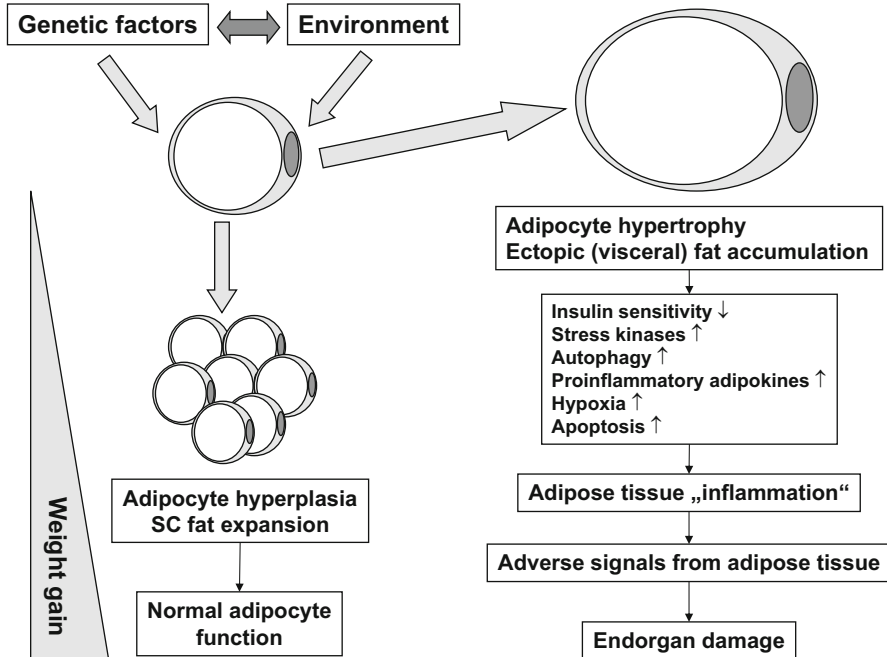

**Fig. 6 Potential mechanisms for the development of adipose tissue dysfunction.** With a chronic excessive energy intake and low physical activity, a positive energy balance causes body weight gain and higher nutrient flux into adipose tissue. Adipocytes primarily respond to the higher demand for energy storage by increasing their size (adipocyte hypertrophy). Adipocyte hypertrophy is typically associated with increased hypoxia, cellular and tissue stress (reflected by activation of JNK, NF- $\kappa$ B, and other stress kinases), increased production of pro-inflammatory cytokines (including TNF- $\alpha$ , IL-1 $\beta$ , monocyte chemoattractant protein-1, chemerin, progranulin, PAI-1), but also activation of autophagy and apoptosis (mainly in visceral depots) and increased release of cell-free DNA. Chemoattractant and endothelial adhesion molecules bind integrins and chemokine receptors on monocytes which subsequently recruits them into adipose tissue. As a result, adipose tissue inflammation may develop

Although adipocytes represent the main parenchymal cell, adipose tissue is composed of several different cell types including preadipocytes, fibroblasts, endothelial cells, and other cells. Adipocytes can be categorized into white, brown, and the more recently described beige or brite adipocytes (Cinti 2012; Cohen and Spiegelman 2015; Waldén et al. 2012). Importantly, the distinction of these adipocyte subtypes was originally based on rodent adipose tissue only, but recently evidence for brown adipose tissue in adult humans could finally prove that heterogeneity in adipose tissue cellular composition can be translated into the human situation (van Marken Lichtenbelt et al. 2009; Cypess et al. 2009). The “adipose organ” has a remarkable plasticity displaying adipocyte transdifferentiation from white into brown phenotypes during chronic cold exposure, physical exercise, lactation, and obesity (Cinti 2012).

**Table 5** Adipokines contribute to the regulation of biological processes. (Modified from Fasshauer and Blüher 2015)

Adipokine	Main actions
<b>Leptin</b>	Satiety signal, regulation of appetite, food intake, locomotor activity, energy expenditure, fertility, and other processes
<b>Adiponectin</b>	Improves insulin sensitivity, antidiabetic, anti-atherogenic, anti-inflammatory
<b>Chemerin</b>	Chemoattractant protein, regulation of adipogenesis
<b>Tumor necrosis factor (TNF) <math>\alpha</math></b>	Pro-inflammatory
<b>Interleukin (IL)-6</b>	Pro-inflammatory
<b>IL-1<math>\beta</math></b>	Pro-inflammatory
<b>Fatty acid binding protein-4 (FABP4)</b>	Associated with increased type 2 diabetes risk and impaired myocardial contractility
<b>Fibroblast growth factor 21 (FGF21)</b>	Stimulates glucose uptake into adipocytes, increases thermogenesis, energy expenditure, fat utilization, improves glucose and lipid metabolism
<b>Retinol-binding protein-4 (RBP4)</b>	Related to insulin resistance, visceral fat distribution, dyslipidemia
<b>Vaspin</b>	Serine protease inhibitor, decreases food intake, improves hyperglycemia
<b>Apelin</b>	Inhibits insulin secretion
<b>Nesfatin-1</b>	Direct glucose-dependent insulinotropic effect on $\beta$ -cells
<b>Visfatin/PBEF/Nampt</b>	Nampt-mediated systemic NAD biosynthesis is critical for $\beta$ -cell function
<b>Monocyte chemoattractant protein-1 (MCP-1)</b>	Chemoattractant protein, adipose tissue inflammation
<b>Progranulin</b>	Chemoattractant protein, neurodegenerative diseases, adipose tissue inflammation
<b>Fetuin-A</b>	Reflects liver fat content, associated with lipid-induced inflammation, insulin resistance, promotes cancer progression
<b>Omentin</b>	Anti-inflammatory, insulin sensitizing
<b>Dipeptidyl peptidase-4 (DPP-4)</b>	Degrades GIP and GLP-1 Inhibitors in clinical use for type 2 diabetes
<b>Clusterin</b>	Promotes tumor progression and angiogenesis
<b>Bone morphogenetic protein-4 (BMP-4)</b>	Regulates adipogenic precursor cell commitment and differentiation
<b>Bone morphogenetic protein-7 (BMP-7)</b>	Stimulates brown adipogenesis, reduces food intake, increases energy expenditure
<b>Cathepsins S, L, K</b>	Regulation of glucose metabolism and adipose tissue mass
<b>Angiopoietin-like protein 8 (Angptl8)</b>	Promotes pancreatic $\beta$ -cell proliferation and improves glucose tolerance
<b>Tissue inhibitor of matrix metalloproteinase-1 (TIMP-1)</b>	Decreases adipogenesis, impairs glucose tolerance
<b>Resistin</b>	Related to obesity, insulin resistance, inflammation
<b>Lipocalin 2</b>	Related to insulin resistance and inflammation

(continued)

**Table 5** (continued)

Adipokine	Main actions
<b>Wnt1 inducible signaling pathway protein 1 (Wisp1)</b>	Regulation of adipogenesis and adipose tissue inflammation
<b>Adipsin</b>	Activation of the alternative complement pathway
<b>Transforming growth factor <math>\beta</math> (TGF<math>\beta</math>)</b>	Regulation of cell proliferation, differentiation, and apoptosis
<b>Vascular endothelial growth factor (VEGF)</b>	Stimulates angiogenesis in adipose tissue

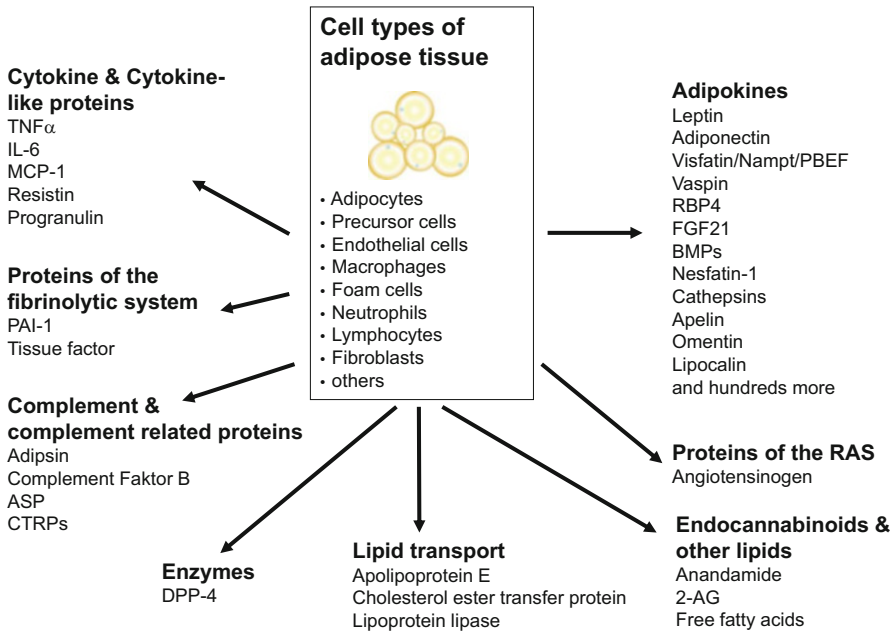

**Fig. 7 Factors released or secreted by adipose tissue.** Adipocytes, immune cells, fibroblasts, endothelial cells, and others contribute to the release of metabolites, lipids, and adipokines. Examples for adipose tissue-derived molecules. *2-AG* 2-arachidonoylglycerol, *ASP* acylating simulation protein, *BMPs* bone morphogenetic proteins, *CTRPs* C1q/TNF-related proteins, *FGF21* fibroblast growth factor 21, *MCP-1* monocyte chemotactic protein-1, *PAI-1* plasminogen activator inhibitor-1, *RAS* renin angiotensin system, *RBP4* retinol-binding protein-4. (Modified from Fasshauer and Blüher 2015)

As an example for the plasticity of adipose tissue to respond to increased demands for fat storage, adipocytes may hypertrophy to volumes larger than 1000 pL or significantly increase their generation rate (hyperplasia) (Waldén et al. 2012). Data demonstrating that adipocyte number is tightly regulated at a constant level and determined during childhood suggest that increasing adipocyte size represents the main plasticity mechanism in response to a chronic positive

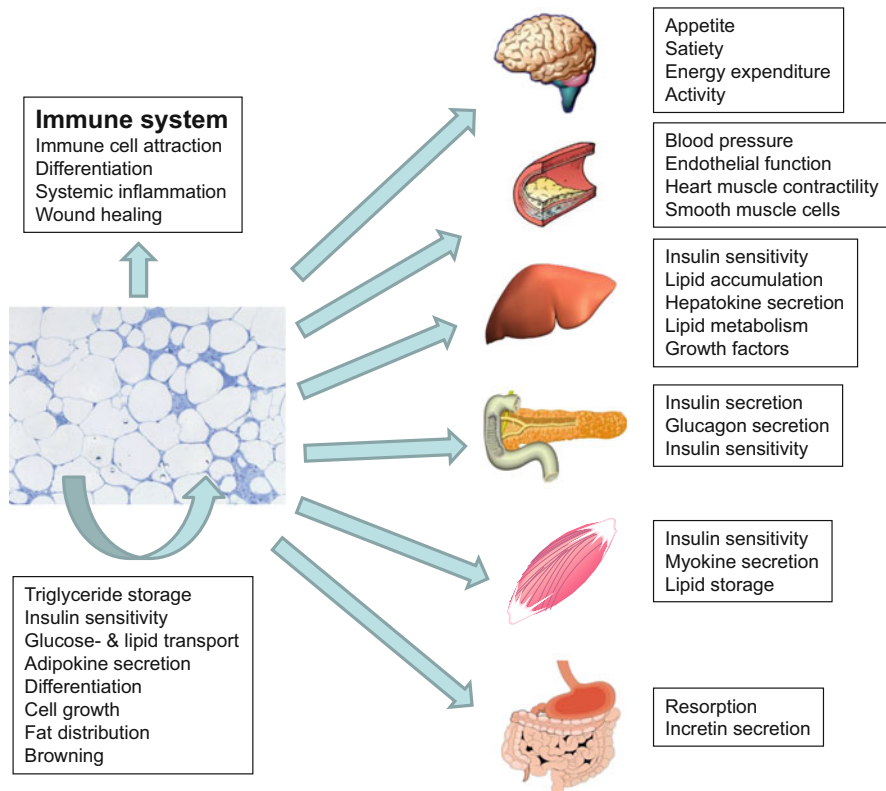

**Fig. 8 Signals from adipose tissue modulate important biologic processes via autocrine, paracrine, and endocrine mode of actions.** Adipokines regulate adipogenesis, adipocyte metabolism, immune cell migration into adipose tissue via autocrine and paracrine signaling. In addition, adipokines have endocrine/systemic effects on appetite and satiety control, regulation of energy expenditure and activity, influence insulin sensitivity and energy metabolism in insulin-sensitive tissues, such as liver, muscle, and fat as well as insulin secretion in pancreatic  $\beta$ -cells. *IL* interleukin, *TNF- $\alpha$*  tumor necrosis factor- $\alpha$ , *MCP-1* monocyte chemoattractant protein-1, *FABP4* fatty acid binding protein 4, *RBP4* retinol-binding protein-4. (Modified from Blüher 2013)

energy balance (Spalding et al. 2008). In contrast to children, late-onset obesity in adults who gain body weight more slowly over years may initially respond to excess energy by adipocyte hypertrophy up to a certain threshold before recruiting precursor cells or mesenchymal stem cells to additionally increase adipocyte number (Spalding et al. 2008).

In an attempt to systemically characterize the changes that occur in adipose tissue from a variety of mouse models of obesity, Weisberg et al. (2003) found that with increasing adiposity, the number of macrophages in adipose tissue increases both in rodent models and humans. In subsequent studies, it was shown that macrophages in adipose tissue cluster around necrotic-like adipocyte death in crown-like structures, suggesting that scavenging of adipocyte debris is an important function of infiltrating



macrophages in obese individuals (Cinti et al. 2005). In patients with obesity, macrophage infiltration has been shown to be significantly higher in visceral compared to subcutaneous adipose tissue (reviewed in Blüher 2016). Interestingly, adipose tissue macrophage number can be reduced by significant weight loss after bariatric surgery (Cancello et al. 2005). In addition to the number of macrophages in adipose tissue, it is important to note that switching the phenotype of macrophages belongs to the alterations associated with adipose tissue inflammation. Changes in the macrophage phenotypes are most likely regulated by cells of the adaptive immune system, i.e., with increasing fat mass upon high caloric intake, recruitment of B cells and T cells may precede macrophage infiltration into adipose tissue (Sell et al. 2012).

Infiltration of adipose tissue with immune cells may be considered a symptom of obesity, and immune cells proliferating in adipose tissue and emigrating to other tissues could link increased adiposity to obesity-related metabolic diseases (Haase et al. 2014).

---

## Prevention of Obesity and Type 2 Diabetes

Obesity and T2D are at least theoretically preventable, and therefore, the most important goal of ultimately reducing the population burden of obesity and diabetes is to prevent the diseases (WHO 2016). Several studies have demonstrated that diabetes can be delayed or prevented in individuals at high risk undergoing an intensive diet and exercise program or pharmacological interventions with metformin, acarbose, thiazolidinediones, or GLP-1 receptor agonists (reviewed in Stumvoll et al. 2005). The observation that improvement in one or more major pathogenic factors offsets or delays the progression from prediabetic states to diabetes underscores the contribution of each of these factors to the development of the disease, including insulin sensitivity,  $\beta$ -cell function, and glucose excursions. Lifestyle modification has been difficult to maintain over a long term and has costs associated with regular visits to various health care professionals and lifestyle coaches. However, the WHO declared that: “supportive environments and communities are fundamental in shaping people’s choices, by making the choice of healthier foods and regular physical activity the easiest choice and therefore preventing overweight and obesity.” At the individual level, people at risk for obesity and T2D may limit energy intake from total fats and sugars, increase consumption of fruit and vegetables, as well as legumes, whole grains and nuts, and engage in regular physical activity (60 min a day for children and 150 min spread through the week for adults) (WHO 2016). A critical prerequisite for these individual opportunities seems to be the access to a healthy lifestyle provided at the societal level. An individual behavior change, which may prevent obesity and T2D, needs to be facilitated by sustained implementation of evidence-based and population-based policies that make regular physical activity and healthier dietary choices available, affordable, and easily accessible to everyone (WHO 2016). In addition, the food industry can play a significant role in promoting healthy diets by reducing the fat, sugar, and salt content

of processed foods, ensuring that healthy and nutritious choices are available and affordable to all consumers, restricting marketing of foods high in sugars, salt, and fats, especially those foods aimed at children and teenagers and ensuring the availability of healthy food choices and supporting regular physical activity practice in the workplace (WHO 2016).

---

## Management of Obesity

Modern treatment strategies of obesity need to be based on the diagnosis of the multifactorial and individually variable determinants of weight gain and the health benefits to be derived from weight loss. The basis for any weight loss intervention is lifestyle change, diet, and increased physical activity. The approach should be a high-quality diet to which patients will adhere accompanied by an exercise prescription describing frequency, intensity, type, and time with a minimum of 150 min moderate weekly activity (Bray et al. 2016). For patients who do not achieve individual health benefit goals from weight loss, management of medications that are contributing to weight gain, and use of approved medications for chronic weight management along with lifestyle changes are appropriate. Medications approved in the USA and the European Union are orlistat, naltrexone/bupropion, and liraglutide 3.0 mg (Bray et al. 2016). In addition, lorcaserin and phentermine/topiramate are approved weight management medications in the USA. Bariatric surgery including gastric banding, sleeve gastrectomy, Roux-en-Y gastric bypass, and other procedures can produce remarkable health improvement and reduce mortality for patients with severe obesity (Bray et al. 2016). In principle, obesity treatment can be escalated when individual treatment goals are not achieved by a stepwise approach (Fig. 9).

Lifestyle and behavioral interventions aimed at reducing calorie intake and increasing energy expenditure have limited long-term success due to complex and persistent hormonal, metabolic, and neurochemical adaptations that defend against weight loss and promote weight regain. On the other hand, more effective surgical treatments are unavailable or unsuitable for the majority of individuals with obesity; therefore, effective and safe pharmacotherapies are urgently needed (Table 6).

The increase in the prevalence of obesity represents a challenging task for health care systems. Since the obesity-associated risk to develop comorbid disorders and the individual response to weight-reducing therapies are heterogeneous, a stratification of the severity of obesity should be assessed prior to the initiation of weight loss interventions (Sharma and Kushner 2009). Bariatric surgery is so far the only long-term effective evidence-based treatment strategy to significantly reduce body weight in patients with obesity. Also in the light of limited resources in health care systems, it will become important to identify those individuals with obesity who may benefit the most from an intervention aiming at body weight reduction. The Edmonton Obesity Staging System (EOSS) has been demonstrated to be a valuable diagnostic tool to stratify and prioritize patients for different treatment strategies including

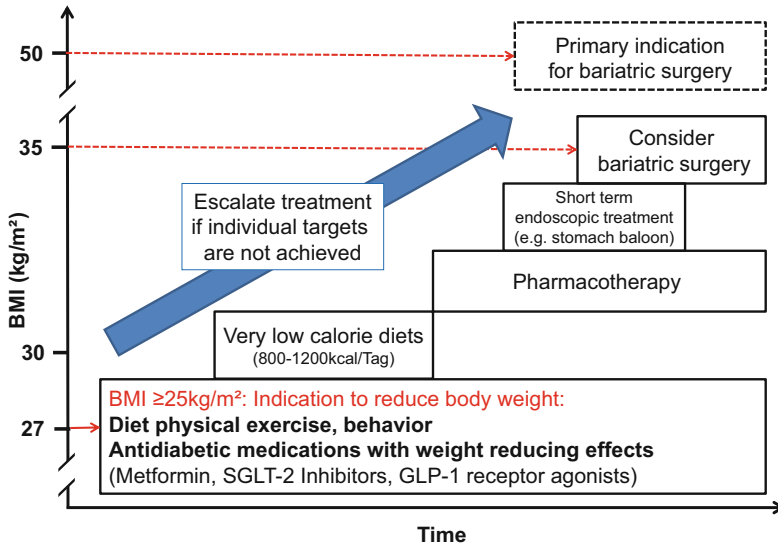

**Fig. 9** Stepwise escalating weight loss strategies in patients with obesity (and type 2 diabetes). The Endocrine Society Clinical Practice Guidelines recommend that diet, exercise, and behavioral modification be included in all overweight and obesity management approaches for BMI  $\geq 25$  kg/m<sup>2</sup> and that other tools such as pharmacotherapy (BMI  $\geq 27$  kg/m<sup>2</sup> with comorbidity or BMI over 30 kg/m<sup>2</sup>) and bariatric surgery (BMI  $\geq 35$  kg/m<sup>2</sup> with comorbidity or BMI over 40 kg/m<sup>2</sup>) be used as adjuncts to behavioral modification to reduce food intake and increase physical activity when this is possible

**Table 6** The Edmonton Obesity Staging System. (From Padwal et al. 2011)

0	No apparent risk factors (e.g., blood pressure, serum lipid, and fasting glucose levels within normal range), physical symptoms, psychopathology, functional limitations, and/or impairment of well-being related to obesity
1	Presence of obesity-related subclinical risk factors (e.g., borderline hypertension, impaired fasting glucose levels, elevated levels of liver enzymes), mild physical symptoms (e.g., dyspnea on moderate exertion, occasional aches and pains, fatigue), mild psychopathology, mild functional limitations, and/or mild impairment of well-being
2	Presence of established obesity-related chronic disease (e.g., hypertension, type 2 diabetes, sleep apnea, osteoarthritis), moderate limitations in activities of daily living and/or well-being
3	Established end organ damage such as myocardial infarction, heart failure, stroke, significant psychopathology, significant functional limitations, and/or impairment of well-being
4	Severe (potentially end-stage) disabilities from obesity-related chronic diseases, severe disabling psychopathology, severe functional limitations, and/or severe impairment of well-being

bariatric surgery (Table 7) (Padwal et al. 2011). The EOSS is a risk-stratification system that classifies individuals with obesity into 5 graded categories, based on their morbidity and health-risk profile. All patients can be provided weight-

**Table 7** Pharmacotherapy of obesity in the USA (2014). (Modified from Apovian et al. 2015)

Drug (generic)	Dosage	Mechanism of action	Mean weight loss (% or kg)	Status	Common side effects	Contraindications
Phentermine resin	37.5 mg/day	Norepinephrine-releasing agent	3.6 kg	Approved in 1960s for short-term use (3 months)	Headache, elevated BP, elevated HR, insomnia, dry mouth, constipation, anxiety Cardiovascular: palpitation, tachycardia, elevated BP, ischemic events Central nervous system: overstimulation, restlessness, dizziness, insomnia, euphoria, dysphoria, tremor, headache, psychosis Gastrointestinal: dryness of the mouth, unpleasant taste, diarrhea, constipation, other gastrointestinal disturbances Allergic: urticaria Endocrine: Impotence, changes in libido	Anxiety disorders (agitated states), history of heart disease, uncontrolled hypertension, seizure, MAO inhibitors, pregnancy and breastfeeding, hyperthyroidism, glaucoma, history of drug abuse, sympathomimetic amines

*(continued)*

Table 7 (continued)

Drug (generic)	Dosage	Mechanism of action	Mean weight loss (% or kg)	Status	Common side effects	Contraindications
Diethylpropion	75 mg/day	Norepinephrine-releasing agents	3.0 kg	FDA approved in 1960s for short-term use (3 months)	See phentermine resin	See phentermine resin
Orlistat	120 mg TID	Pancreatic and gastric lipase inhibitor	2.9–3.4 kg	FDA approved in 1999 for chronic weight management	Decreased absorption of fat-soluble vitamins, steatorrhea, oily spotting, flatulence with discharge, fecal urgency, oily evacuation, increased defecation, fecal incontinence	Cyclosporine (taken 2 h before or after orlistat dose), chronic malabsorption syndrome, pregnancy and breastfeeding, cholestasis, levothyroxine, warfarin, antiepileptic drugs
Lorcaserin	10 mg BID	5HT <sub>2c</sub> receptor agonist	3.6 kg	FDA approved in 2012 for chronic weight management	Headache, nausea, dry mouth, dizziness, fatigue, constipation	Pregnancy and breastfeeding Use with caution: SSRI, SNRI/MAOI, St John's wort, triptans, bupropion, dextromethorphan

Phentermine (P)/topiramate (T)	3.75 mg P/23 mg T ER QD (starting dose) 7.5 mg P/46 mg T ER daily (recommended dose) 15 mg P/92 mg P/T ER daily (high dose)	GABA receptor modulation (T) plus norepinephrine-releasing agent (P)	6.6 kg (recommended dose), 8.6 kg (high dose)	FDA approved in 2012 for chronic weight management	Insomnia, dry mouth, constipation, paresthesia, dizziness, dysgeusia	Pregnancy and breastfeeding, hyperthyroidism, glaucoma, MAO inhibitor, sympathomimetic amines
Naltrexone/bupropion	32 mg/360 mg <sup>2</sup> tablets QID (high dose)	Reuptake inhibitor of dopamine and norepinephrine (bupropion) and opioid antagonist (naltrexone)	4.8%	FDA approved in 2014 for chronic weight management	Nausea, constipation, headache, vomiting, dizziness	Uncontrolled hypertension, seizure disorders, anorexia nervosa or bulimia, drug or alcohol withdrawal, MAO inhibitors
Liraglutide	3.0 mg injectable	GLP-1 agonist	5.8 kg	FDA approved in 2014 for chronic weight management	Nausea, vomiting, pancreatitis	Medullary thyroid cancer history, multiple endocrine neoplasia type 2 history

management advice; however, patients in the first 2 stages (EOSS stages 0 and 1) may not necessarily require weight loss, as they represent an obese phenotype with relatively minor health problems (Sharma and Kushner 2009). This is in contrast to the typical obese phenotype that is associated with several clinical metabolic, mental, and physiological aberrations (EOSS stages 2–4) (Sharma and Kushner 2009).

Noteworthy, studies including real-world observations are required to validate the EOSS in clinical practice and whether obesity treatment could be optimized using this systematic approach. In analyses of data from the National Health and Human Nutrition Examination Surveys (NHANES) III (1988–1994) and the NHANES 1999–2004, with mortality follow-up through to the end of 2006, it has been shown that EOSS independently predicted increased mortality even after adjustment for contemporary methods of classifying adiposity (Fig. 10) (Padwal et al. 2011). Before the initiation of individual weight management plans, assessment of the obesity-related risk using the EOSS may therefore help to prioritize treatment of patients at highest risk for obesity-related premature mortality (Padwal et al. 2011). To structure the treatment of a patient with obesity, several guidelines have been developed in different countries of the world (reviewed in Bray et al. 2016).

---

## Treatment of Obesity in Patients with Type 2 Diabetes

For patients with obesity-related T2D, achieving a healthier body weight is a central component in the treatment strategy (Hauner 2010). In the LOOK AHEAD study, patients with T2D could achieve clinically significant weight loss with an average 8.6% weight loss in the intensive lifestyle intervention group after 1 year of treatment (LOOK AHEAD Research Group 2013). Weight loss was accompanied by substantial improvements of all weight-associated risk factors including improvements in HbA1c (from 7.3% (56 mmol/mol) at baseline to 6.2% (44 mmol/mol) after 1 year) (LOOK AHEAD Research Group 2013). In general, treatment of patients with obesity and T2D is usually considered to be more difficult than treating obese subjects without diabetes. This may apply as early as at prediabetes states. For example, in the SCALE obesity and prediabetes trial, reducing body weight by liraglutide 3.0 mg was more pronounced in those individuals with normal glucose metabolism compared to the prediabetes patients (Pi-Sunyer et al. 2015). There are several reasons for the less effective weight-reducing programs in patients with T2D compared to those with obesity and normoglycemia. T2D patients are usually older than obese subjects without diabetes, which may mean a smaller weight loss as energy expenditure decreases with age (Hauner 2010). Another reason is that T2D patients may focus more on blood glucose control, which could result in neglecting other health problems (Hauner 2010). Finally, the effect of various antidiabetic agents to increase weight or prevent weight loss has to be considered (Hauner 2010).

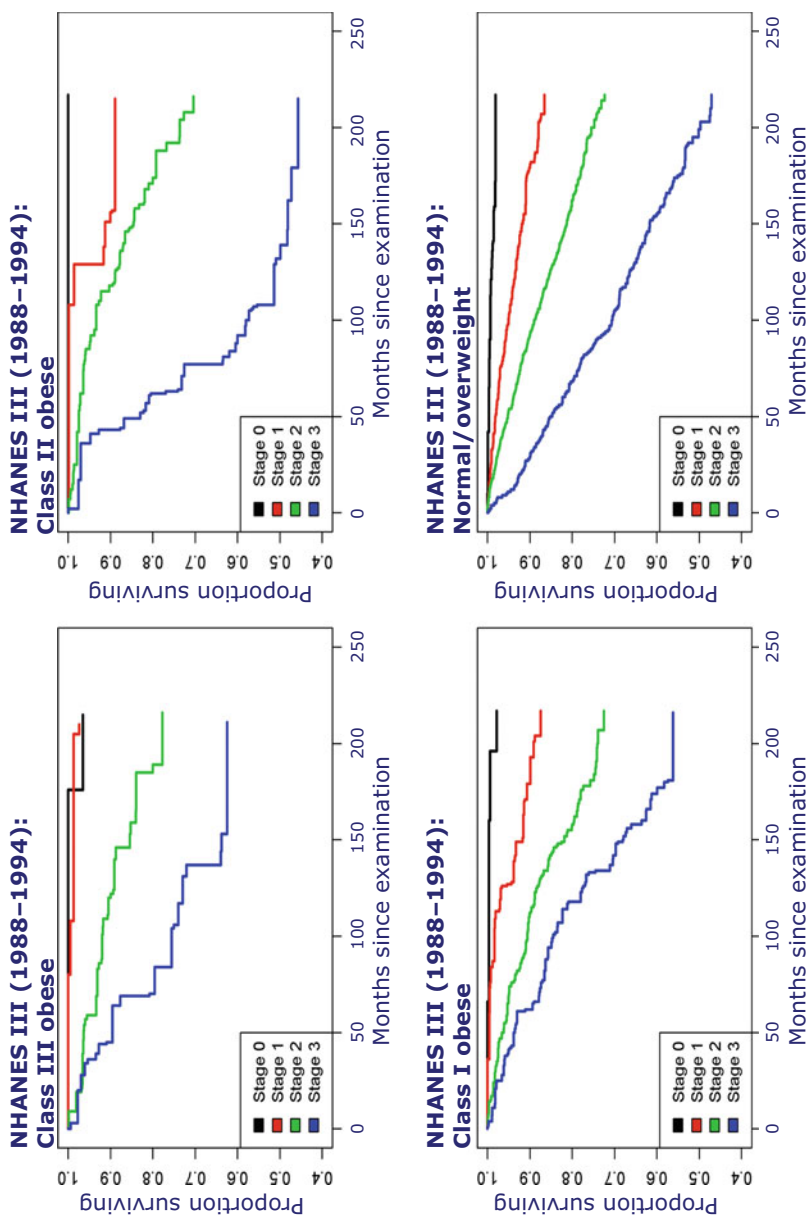

**Fig. 10** The Edmonton Obesity Staging System predicts all-cause mortality among people with normal weight, overweight, and obesity. NHANES = National Health and Human Nutrition Examination Surveys. (Reproduced and modified from Padwal et al. 2011)



## Behavior Modifications

Obesity develops in genetically predisposed people because of chronically increased intake of energy-dense foods that are high in fat and carbohydrates in parallel with a low physical activity due to the modern sedentary nature of the work, facilitated modes of transportation, and increasing urbanization. These components characterize a “modern lifestyle” in many societies, and therefore interventions aiming at changing this lifestyle are considered as cornerstone of weight-reducing treatment. On the other hand, the term lifestyle intervention is misleading, because it would require an intervention at both the individual and societal level, which goes far beyond the medical perspective of an individualized obesity treatment. Therefore, here the term behavior modification will be used instead of “lifestyle intervention” as basis for any more specific obesity treatment. International guidelines for treatment of obesity recommend a multicomponent behavior intervention, which includes three major strategies: lifestyle or behavioral training, dietary approaches to reduce energy intake, and an increase in physical activity (Bray et al. 2016). Patients with obesity following the goal to reduce their body weight and maintain a healthier body weight should ideally follow the behavior intervention lifelong. However, the efficacy and adherence rates to multimodal behavior interventions are generally very low. Therefore, the effectiveness of treatments aiming at behavior changes is considered relatively low. On the other hand there is increasing evidence supporting the efficacy of lifestyle intervention or behavioral modification from large randomized and controlled trials. The Look AHEAD study (Look AHEAD Research Group et al. 2013) and the Diabetes Prevention Program (Knowler et al. 2009) are prominent examples to support the notion that behavior intervention could be successfully used – even in the long term – to reduce body weight and improve measures of obesity-related disorders. In the LOOK AHEAD trial, number of attended face-to-face behavioral sessions, number of meal replacements, and accumulative weekly physical activity were predictors of weight after 1, 4, and 8 years (Look AHEAD Research Group et al. 2013). If these components could be delivered in at least 14 group or individual sessions over 6 months with treatment continuing to 1 year, the average reported weight loss would be 8 kg (Bray et al. 2016). Although the extent of weight may seem small, this weight loss was associated with clinically significant improvements in obesity-related traits including lowering of systolic and diastolic blood pressure, triglycerides, and parameters of glycemic control, increasing HDL-cholesterol, and reduction in risk for progression to type 2 diabetes (Ryan and Heaner 2014; Bray et al. 2016).

Based on the results of the LOOK AHEAD trial and other supportive evidence, the US Preventive Services Task Force (LeFevre and U.S. Preventive Services Task Force 2014) has recommended that individuals with obesity and cardiovascular disease risk factors should be referred for lifestyle treatment, and the US Center for Medicare and Medicaid Services promote policies to reimburse providers for intensive behavioral therapy for the patient with obesity (Bray et al. 2016). In the UK, the National Institute for Health and Care Excellence recommends progressively intensive interventions on the basis of the degree of

overweight and obesity and presence of comorbidities (Bray et al. 2016). Importantly, initial rates of weight loss predicted long-term weight loss in the LOOK AHEAD trial – an observation which could also be attributed to other weight loss interventions including dietary approaches (Greenberg et al. 2009; Shai et al. 2008) and pharmacotherapy (Pi-Sunyer et al. 2015). In the LOOK AHEAD trial, individuals losing less than 3% of their body weight at 2 months were 2.5% below the average baseline weight at 8 years, whereas those losing 3–6% of their body weight were about 4.5% below baseline at 8 years, and those losing more than 6% were ~7% below baseline on average at 8 years, suggesting that larger early weight losses are beneficial (Bray et al. 2016; Unick et al. 2015). There are many commercial programs that can provide tools to facilitate individual behavior changes and support weight loss (Gudzune et al. 2015). On average, commercial behavior change-based weight loss programs lead to a weight loss of ~3% in the first year – however, long-term adherence to such programs is generally poor (Gudzune et al. 2015). Despite several claims regarding the superiority of one program or another for inducing weight loss, a recent meta-analysis comparing 48 unique randomized trials (including 7286 individuals) found that significant weight loss was observed with any low-carbohydrate or low-fat diet (Johnston et al. 2014). These analyses support the practice of recommending any multimodal behavior program or diet that a patient will adhere to in order to lose weight (Johnston et al. 2014).

---

## Diets for Weight Loss

Patients and health care professionals are frequently facing the belief that there is a magic weight loss diet (Bray et al. 2016). This belief has stimulated many studies that have compared low-fat, low-carbohydrate or high-protein, low glycemic index, balanced deficit diets. However, meta-analyses of these studies demonstrated that reduced-calorie diets result in clinically meaningful weight loss regardless of which macronutrients or diet composition they emphasize (Sacks et al. 2009).

On the other hand, dietary approaches for weight loss represent the most important nonpharmacological, nonsurgical treatment strategy for patients with obesity including patients with obesity and T2D. The basic principle of a weight reduction program includes a moderately hypocaloric diet, an increase in physical activity, and behavior modification (Hauner 2010). The gold standard in the dietary treatment of obese patients with or without T2D is a balanced moderately energy-restricted diet with an energy deficit of at least 500 kcal/day below energy requirements (Hauner 2010). Alternatively, patients may use a dietary plan that has 1200–1500 kcal/day for women or 1500–1800 kcal/day for men (increased by a further 300 kcal/day for each sex if weight exceeds 150 kg) (Bray et al. 2016).

In a large study of 811 participants with overweight and obesity, the effects of diets with 20% or 40% fat and 15% or 25% protein were compared and reported no difference in weight loss at 6 months or 2 years attributable to any specific diet composition (Sacks et al. 2009). Additional meta-analyses of low-carbohydrate

versus low-fat diets support the notion that low-carbohydrate diets are at least as effective as low-fat diets at reducing weight and improving metabolic risk factors (Hu et al. 2012). Following the results from these trials and meta-analyses, the best advice to patients aiming at weight loss to improve their health is to provide low-energy diets that are likely to be adhered to by the patient and provide health benefits. In patients with nephropathy, however, protein intake remains a critical issue and should be limited in accordance with current recommendations (Hauner 2010).

From the DIRECT study, a 2-year trial, in which 322 moderately obese subjects have been randomly assigned to one of three diets – low fat, restricted calorie; Mediterranean, restricted calorie; or low carbohydrate, nonrestricted calorie – it has been suggested that a Mediterranean-style diet had favorable effects particularly with regard to adherence rates and practicability (Shai et al. 2008). Moreover, in a meta-analysis of nine studies with 1178 patients, Mediterranean-style diets were associated with a significant decrease in body weight and BMI and reductions in HbA1c, fasting plasma glucose, fasting insulin, and cardiovascular disease risk (Huo et al. 2014).

From a practical point of view, it is important to assess the habitual diet of patients with T2D and to focus counseling on changes of their eating habits in order to approach current dietary recommendations (Hauner 2010). All possible efforts for dietary changes should be made as simple as possible for patients as they may also be burdened by many requirements to manage their diabetes (Hauner 2010). For obese subjects with T2D, the frequent recommendation to distribute their restricted calorie intake over five to six meals is difficult to meet and may even hinder weight loss without being of any advantage for metabolic control (Hauner 2010). Therefore, in T2D patients without insulin treatment, three meals a day may be more appropriate and advantageous to reach the individual dietary and weight goals.

It is still debated whether low glycemic index or low glycemic load diets are superior in the dietary treatment of patients with T2D (Bray et al. 2016). Study data comparing such strategies are inconclusive (Bray et al. 2016).

In the model of a stepwise escalating weight loss therapy (Fig. 10), the use of a very low calorie diet (VLCD) could be recommended for initial (short-term) weight loss.

VLCDs or very low-energy diets are defined as having 200 and 800 kcal/day and provide a lower energy intake that might result in more rapid loss of body fat and weight (Bray et al. 2016). It could be shown that VLCDs can rapidly normalize blood glucose and other risk factors in people with type 2 diabetes. Therefore, this option may be particularly valuable for patients with poor metabolic control (Hauner 2010). Dietary restriction in the context of short periods of VLCD leads to a rapid improvement of insulin sensitivity and glycemic control. VLCDs can only be applied for a limited period of time and require intensive medical surveillance. The long-term results of VLCD are moderately better than those of conventional diets, although there is considerable weight regain after VLCD short-term interventions (Anderson et al. 2001). Therefore, there is need for new sophisticated solutions such as intermittent VLCD in combination with conventional hypocaloric diets to obtain better long-term results (Hauner 2010). In an analysis of commercial

programs, it could be demonstrated that medically monitored VLCD programs (e.g., Health Management Resources, Medifast, OPTIFAST) resulted in at least 4.0% greater short-term weight loss than counseling (Gudzune et al. 2015).

---

## Increasing Physical Activity

Increased physical activity is an essential and integral component of behavior modification programs (Bray et al. 2016). Different guidelines recommend typically a gradually increasing aerobic physical activity (e.g., walking, cycling) to reach a goal of more than 150 min/week (equal to >30 min/day, for at least 5 days each week) (Jakicic et al. 2013; National Clinical Guideline Centre (UK); Bray et al. 2016). Increased physical activity may not be effective in weight loss without a parallel diet intervention. However, weight maintenance after losing weight as well as significant benefits for general health and even reduced mortality (Paffenbarger et al. 1986) that are independent of weight loss could be achieved by increased physical activity (Wu et al. 2009). Importantly, low cardiorespiratory fitness is a strong and independent predictor of cardiovascular disease (CVD)-related and all-cause mortality and of comparable importance with that of diabetes mellitus and other CVD risk factors in patients with obesity (Wei et al. 1999). There is evidence that a greater amount of physical activity (30–45 min/day) is needed to prevent obesity and that for long-term weight maintenance in those who have lost weight, 60–90 min/day is required, but this is likely to require close supervision as part of an intensive program, which might not be practical or sustainable in many clinical settings (Bray et al. 2016). As an example from the LOOK AHEAD trial, although physical activity is effective in the short term, the activities and their benefits are not always sustained (Look AHEAD Research Group et al. 2013). The type of physical activity including strength versus endurance, aerobic versus resistance, or high-intensity versus low-intensity training does not seem to be related to overall weight loss (Bray et al. 2016). With regard to practicability, more intensive exercise programs may produce similar weight loss with a reduced time commitment and could therefore be preferred by patients with obesity. In general and in analogy to behavior programs and diet approaches, long-term adherence to increased physical activity is the most important goal.

---

## Antidiabetic Medications and Body Weight

It has long been recognized that some glucose-lowering medications can promote weight gain in patients with T2D. The strongest weight-promoting effect is exerted by insulin. In the Diabetes Control and Complications Trial (DCCT), intensified insulin treatment was associated with substantial weight gain that resulted in unfavorable changes of lipid levels and blood pressure similar to those seen in the insulin resistance syndrome (Purnell et al. 1998). In the UK Prospective Diabetes Study (UKPDS), insulin treatment caused a mean weight gain of approximately 7 kg over

12 years of treatment in newly diagnosed subjects with T2DM (UKPDS study group 1998). In addition, sulfonylureas and glinides are known to promote weight gain because of their action to promote insulin secretion. In the UKPDS, the average weight gain under glibenclamide treatment amounted to about 5 kg (UKPDS study group 1998).

Glitazones lead to substantial weight gain of 4–5 kg on average, mainly in subcutaneous depots and by enhanced fluid retention (Hauner 2010). In contrast, metformin and  $\alpha$ -glucosidase inhibitors have a modest weight-lowering potential (Hauner 2010). DPP-4 inhibitors (e.g., alogliptin, sitagliptin, linagliptin, saxagliptin, vildagliptin) have been shown to be weight neutral, whereas the administration of sodium glucose cotransporter-2 (SGLT-2) inhibitors (e.g., canagliflozin, dapagliflozin, empagliflozin) and GLP-1 receptor agonists (e.g., exenatide, liraglutide, dulaglutide, lixisenatide) results in a substantial weight loss, and liraglutide in a dose of 3.0 mg daily is an approved weight management pharmacotherapy in the USA, Canada, and Europe (Drucker and Nauck 2006).

---

## Pharmacotherapy of Obesity

In the stepwise escalating weight loss treatment algorithm (Fig. 10), the adjunct administration of weight-lowering drugs represents another component in the treatment of obesity (Hauner 2010). As the efficacy of currently approved drugs is limited, drug treatment is only recommended if the nonpharmacologic treatment program is not sufficiently successful and if the benefit to risk ratio justifies drug administration (National Task Force on the Prevention and Treatment of Obesity 1996). This means if patients do not achieve individual health benefit goals (typically <5% weight loss), the use of approved weight loss medications for chronic weight management along with lifestyle changes is appropriate (Bray et al. 2016). There are differences in the approval status of different medications for weight loss in different countries and regions of the world (Table 5). In the USA and the European Union, orlistat, naltrexone/bupropion, and liraglutide 3.0 mg are approved (Bray et al. 2016). Only in the USA, lorcaserin and phentermine/topiramate are approved for weight management. Most of the approved drugs are working centrally where stimulation of the POMC/CART pathway has anorexigenic effects, whereas the NPY/AGRP pathway exerts orexigenic effects. The interaction with the several receptors present in neurones of the hypothalamus determines the balance between orexigenic and anorexigenic effects (Schwartz et al. 2000).

Independently of the approved weight loss drugs, patients with obesity (and T2D) should be guided with regard to avoid wherever possible medications for other indications, which may induce weight gain interfere with weight loss goals. A clinical guidance statement from the Endocrine Society promotes the concept that for patients with obesity, medicating for chronic diseases should be with a weight-centric focus (Bray et al. 2016). Many medications in use for common chronic diseases produce weight gain, and others are associated with weight loss, albeit those medications do not have an obesity indication (summarized in Bray et al. 2016).

The indications for adding pharmacotherapy to a basic multimodal weight loss program are a failure to achieve clinically meaningful weight loss (>5% of total body weight) and to sustain lost weight, for patients who meet regulatory prescribing guidelines (BMI  $\geq 27$  kg/m<sup>2</sup> with one or more comorbidities or a BMI  $>30$  kg/m<sup>2</sup> with or without associated cardiometabolic disorders). When prescribing the approved five medications in the USA and three in the EU (Table 5), some guiding principles need to be followed. Most importantly, in parallel with the weight loss medication, an effective behavior support for weight loss should be provided. Medications work to reinforce the patient's attempts to change eating behaviors and produce an energy deficit. In addition, the potential pharmacotherapy-related risks and side effects should be known and explained in detail to the patient to make informed choices. If clinically meaningful weight loss cannot be achieved with the pharmacotherapy within the first 3 months, medications should be discontinued, and a new treatment plan needs to be implemented (Bray et al. 2016). Meaningful weight could be defined as loss of more than 5% of body weight in patients without diabetes or loss of >3% of body weight in patients with obesity and T2D (Bray et al. 2016). Noteworthy, the responder rate to any antiobesity pharmacotherapy is not 100%, but patients who may not respond to one medication could achieve relevant weight loss with another medication.

Before the approval of a weight loss medication by the medical regulatory agencies in the USA and EU, data for more than 2500 patients have to be provided and weight loss needs to be approximate to or exceed 5% greater weight loss than lifestyle intervention (placebo). In addition, positive effects on various risk factors and disease markers need to be shown (Bray et al. 2016). All drugs must show evidence of no increase in cardiovascular risk, which is likely to require a cardiovascular outcome trial either before or after marketing. Furthermore, all of the drugs (Table 5) were studied with a suicidality rating scale. These medications have an indication for chronic weight management, indicating long-term usage, along with diet and physical activity in individuals with BMI of 30 kg/m<sup>2</sup> or greater or a BMI 27 kg/m<sup>2</sup> or greater with one or more comorbidities. They are to be used in the long term not only to produce weight loss but also to sustain weight loss.

Orlistat is a gastric and pancreatic lipase inhibitor that impairs the intestinal absorption of 30% of ingested fat when eating a 30% fat diet. It is available in most countries worldwide and belongs to the safest drugs in this category. Therefore, orlistat has been approved for use in adolescents (Bray et al. 2016). In a recent systematic review of clinical studies over at least 12 weeks in obese subjects with T2DM, orlistat treatment produced a greater weight loss than placebo treatment by 2.0 kg on average, associated with a small improvement in HbA1c compared with controls (Norris et al. 2005). Furthermore, orlistat moderately decreases low-density lipoprotein (LDL) cholesterol concentrations. The XENDOS study could demonstrate over 4 years orlistat's safety and efficacy as well as that it reduces the development of T2D in a high-risk population of individuals with prediabetes (Torgerson et al. 2004). However, the drug's gastrointestinal side effects limit its popularity with patients (Bray et al. 2016).

Phentermine is a sympathomimetic drug with cardiostimulatory properties. It has only been studied in short-term trials and is a controlled substance in the USA (Bray et al. 2016). It has misuse potential (albeit small) and small risk of primary pulmonary hypertension (Bray et al. 2016).

Lorcaserin is a specific serotonin 2c receptor agonist with a favorable tolerability and low rate of adverse events profile (Smith et al. 2010). Lorcaserin should not be used with monoamine oxidase inhibitors because of the risk of serotonin syndrome (Bray et al. 2016).

The combination of phentermine and topiramate as an extended release (ER) formulation uses lower doses of both drugs (7.5 mg of phentermine and 46 mg of topiramate at the recommended dose) than are usually prescribed when either drug is used alone for other indications (Gadde et al. 2011). Topiramate is associated with fetal toxic effects (oral clefts); therefore, a pregnancy test before initiation of therapy, and monthly thereafter, is recommended. The most common side effects include paresthesias, dizziness, dysgeusia, insomnia, constipation, and dry mouth (Bray et al. 2016). A rare side effect of topiramate is acute myopia with glaucoma and the drug is contraindicated in glaucoma. The combination of phentermine and topiramate is also contraindicated in hyperthyroidism and within 14 days of treatment with monoamine oxidase inhibitors. Other rare potential adverse risks include kidney stones (associated with topiramate) and increased heart rate (associated with phentermine) in patients susceptible to sympathomimetic drugs (Bray et al. 2016).

The combination of naltrexone/bupropion has been approved in the USA in 2012 and in the EU in 2015. Bupropion is a mild reuptake inhibitor of dopamine and norepinephrine. Naltrexone, an opioid antagonist, has minimum effect on weight loss on its own, but it is likely to block the inhibitory effects of opioid receptors activated by the  $\beta$ -endorphin released in the hypothalamus that stimulates feeding (Bray et al. 2016). The latter mechanism may support the inhibitory effects of  $\alpha$ -melanocyte stimulating hormone to reduce food intake. Regarding side effects, naltrexone/bupropion can increase blood pressure, and therefore the combination should only be prescribed to patients with controlled hypertension and the patient's blood pressure should be monitored after initiation of the treatment (Bray et al. 2016). Tolerability issues, especially nausea, on initiating the drug require a dose escalation over 4 weeks. All antidepressants in the USA are required to carry a black box warning of suicidality, and the combination's label includes this despite the fact that there was no signal for suicidality in phase 3 studies of naltrexone/bupropion (Bray et al. 2016).

Liraglutide is an injectable GLP-1 agonist which has been used for the management of diabetes at doses of up to 1.8 mg (Pi-Sunyer et al. 2015). For chronic weight management, it is approved in the USA and EU at a dose of 3.0 mg. Nausea has been one of the most prominent side effects; thus, a slow dose escalation over 5 weeks is recommended. In clinical trials, a small but significant increase in heart rate has been observed, whereas blood pressure tends to fall (Bray et al. 2016). Liraglutide should not be prescribed in patients with family or personal history of medullary thyroid cancer or multiple endocrine neoplasia. Other rare side effects include acute pancreatitis, gall bladder disease, and hypoglycemia in patients with T2D

particularly if they are co-treated with medication which causes hypoglycemia (insulin, sulfonylureas).

---

## Bariatric and Metabolic Surgery

As the most invasive option to treat obesity (Fig. 10), bariatric surgery has become an established method to reduce body weight in patients with extreme obesity ( $>40 \text{ kg/m}^2$ ) (Hauer 2010). In addition, there is growing consensus that this method can also be applied in patients with T2D at a BMI  $\geq 35 \text{ kg/m}^2$ . In patients fulfilling these criteria, bariatric surgery is the most effective treatment with excellent long-term results compared to all other methods (Hauer et al. 2010). Several bariatric surgery procedures including gastric banding, sleeve gastrectomy, Roux-en-Y gastric bypass, biliopancreatic diversion, and others are now well established and result in varying degrees of weight loss ranging from  $\sim 11.4\%$  (gastric banding) to  $\sim 21.9\%$  (Roux-en-Y gastric bypass) weight loss (Bray et al. 2016). Each surgical procedure has its own risks and benefits which need to be considered carefully with each patient.

In the Swedish Obese Subjects (SOS) study, a large prospective trial comparing bariatric surgery with conventional (dietary) obesity treatment, sustained ( $>15$  years) weight loss of more than 20 kg was achieved in the surgically treated subjects (Sjöström et al. 2007). In the context, the SOS study bariatric surgery reduced the incidence of T2D and significantly reduced total mortality by  $\sim 24\%$  mainly due to reduced cardiovascular mortality and cancer mortality in women (Sjöström et al. 2012). In a meta-analysis of bariatric surgery studies among patients with obesity and T2D, a 78% complete remission of diabetes has been shown at least in the short term (Buchwald et al. 2009). Fifteen-year data from the SOS study demonstrate that the diabetes remission rates decreased to 30.4% for bariatric surgery patients (controls: 6.5%). Compared to medical treatment alone, bariatric surgery has been shown to be more effective in improving hyperglycemia, hypertension, and dyslipidemia in randomized clinical trials among patients with obesity and type 2 diabetes (Bray et al. 2016). On the other hand, surgery has the risk for acute perioperative complications, long-term micronutrient deficiencies, and psychological problems. Weighing these risks against the benefits of significant weight loss and improved glycemic control, bariatric surgery seems to be a promising treatment option for obesity-associated T2D (Table 8).

Despite growing evidence that bariatric/metabolic surgery powerfully improves T2D, existing diabetes treatment algorithms do not include surgical options (Rubino et al. 2016). To overcome the neglect of data from bariatric surgery trials, an international consensus conference (2nd Diabetes Surgery Summit) developed global guidelines to inform clinicians and policymakers about benefits and limitations of metabolic surgery for T2D. Although additional studies are needed to further demonstrate long-term benefits, there is sufficient clinical and mechanistic evidence to support inclusion of metabolic surgery among antidiabetes interventions for people with T2D and obesity (Rubino et al. 2016).



**Table 8 Comparisons between medical and surgical treatment of type 2 diabetes in patients with obesity.** Selected studies with a duration between 1 and 3 years in which medical and surgical treatment were directly compared. For studies including different surgical procedures, only data for Roux-en-Y gastric bypass (RYGB) surgery were included \*, indicates significant differences ( $p < 0.05$ ) between medical and surgical treatment. (Modified from Tham et al. 2014)

Clinical trial	Schauer et al. 2012		Mingrone et al. 2012		Schauer et al. 2014	
	1 year	2 years	2 years	3 years	3 years	3 years
Duration	Conservative	Surgery (RYGB)	Conservative	Surgery (RYGB)	Conservative	Surgery (RYGB)
Changes						
Body weight (kg)	-5.4 ± 8.0	-29.4 ± 8.9*	-4.7 ± 6.4	-33.3 ± 7.9*	-4.3 ± 8.8	-26.2 ± 10.6*
HbA1c (%)	-1.4	-2.9*	-0.8	-2.2*	-0.6 ± 2.5	-2.5 ± 1.9*
Diabetes medications	Increased	Reduced	Increased	Reduced	Increased	Reduced

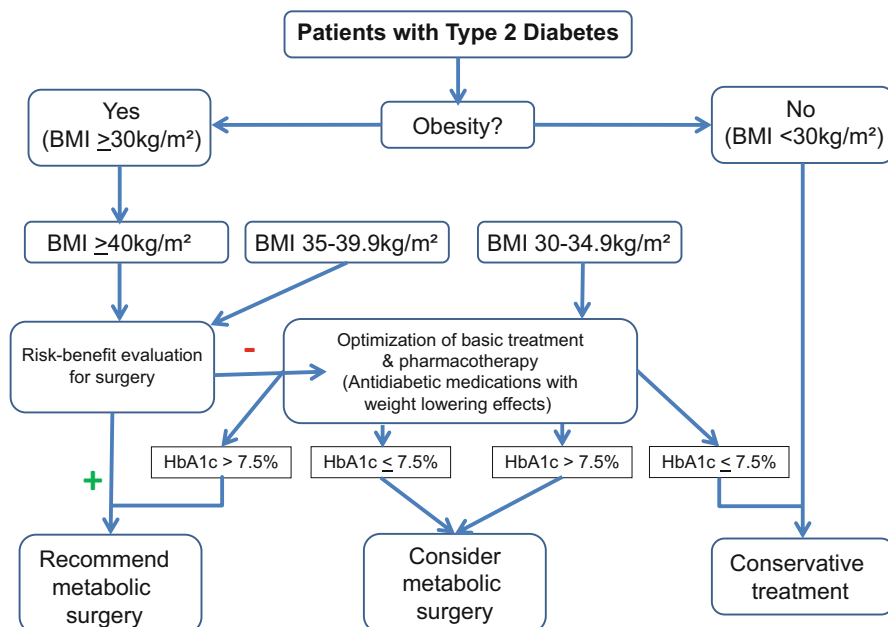

**Fig. 11 Metabolic surgery in the treatment of patients with type 2 diabetes.** Algorithm as recommended by the 2nd Diabetes Surgery Summit voting delegates (Modified from Rubino et al. 2016). Patient selection for metabolic surgery should be based on balancing surgical and other long-term risks with potential long-term benefits to individual patients

Numerous randomized clinical trials (Table 6), albeit mostly short/midterm, demonstrate that metabolic surgery achieves very good glycemic control and reduces cardiovascular risk factors. On the basis of such evidence, metabolic surgery should be recommended to treat T2D in patients with BMI  $\geq 40$  kg/m<sup>2</sup> and in those with BMI 35.0–39.9 kg/m<sup>2</sup> when hyperglycemia is inadequately controlled by lifestyle and optimal medical therapy (Fig. 11). According to the Joint Statement by International Diabetes Organizations (Rubino et al. 2016), surgery may also be considered for patients with T2D and BMI 30.0–34.9 kg/m<sup>2</sup> if hyperglycemia is inadequately controlled despite optimal treatment with either oral or injectable medications (Fig. 11).

These encouraging data from randomized clinical trials comparing bariatric/metabolic surgery with the best medical treatment of T2D patients (Schauer et al. 2012, 2014; Mingrone et al. 2012) need to be put into the context of potential risks and side effects of surgery, which for some patients can be distressing or disabling. Although mortality is low for modern laparoscopic surgery (~0.1–0.3% perioperative mortality), reoperation rates for surgical complications are high, particularly for gastric banding (Chang et al. 2014).

Patients require a lifelong replacement therapy and monitoring is required for nutritional vitamin and mineral deficiencies, particularly after malabsorptive surgery (Bray et al. 2016).

In addition to the acute surgery-associated risks (Birkmeyer et al. 2013), long-term risks including osteoporosis, malnutrition, vitamin deficiencies, dumping syndrome, gastroesophageal reflux, and hypoglycemia can be distressing and challenging to treat (Tack and Deloose 2014). Weight regain can also be a substantial issue, and revisional surgery carries greater risks and no guarantee of success (Bray et al. 2016). From a clinical perspective, patients and clinicians considering referral for bariatric surgery should be made fully aware of the risks and benefits; good practice might include provision of a detailed education session, attendance at patient support groups, and detailed lifestyle advice and psychological support both before and after surgery (Bray et al. 2016).

---

## Conclusions

Obesity increases the risk to develop T2D, and in recent years several potential mechanistic links have been elucidated. Not only excess body fat, but also adverse (ectopic) fat distribution and dysfunction of adipose tissue promote through the release of metabolites, adipokines, and cytokines impaired insulin sensitivity and deteriorate insulin secretion. Body weight management is the central component in the treatment of patients with obesity and T2D, because weight loss has been shown to provide a marked improvement in metabolic control and may reduce the obesity-associated risk for T2D but also several other diseases. Weight management includes an escalating approach which consists of behavioral treatment with the aim to reduce hypercaloric nutrition and to increase physical activity as basic strategy, pharmacotherapy, and bariatric surgery. Recently, bariatric surgery has been shown to be effective in the treatment of patients with T2D.

---

## References

- American Diabetes Association (ADA). Diagnosis and Classification of Diabetes Mellitus. *Diabetes Care*. 2010;33(Suppl 1):S62–S69.
- American Diabetes Association (ADA). Classification and diagnosis of diabetes. *Diabetes Care*. 2015;38(Suppl 1):S8–S16.
- Anderson JW, Konz EC, Frederich RC, Wood CL. Long-term weight-loss maintenance: a meta-analysis of US studies. *Am J Clin Nutr*. 2001;74:579–84.
- Apovian CM, Aronne LJ, Bessesen DH, McDonnell ME, Murad MH, Pagotto U, Ryan DH, Still CD. Pharmacological management of obesity: an endocrine society clinical practice guideline. *J Clin Endocrinol Metab*. 2015;100:342.
- Belfort R, Mandarino L, Kashyap S, et al. Dose response effect of elevated plasma FFA on insulin signaling. *Diabetes*. 2005;54:1640–8.
- Birkmeyer JD, Finks JF, O'Reilly A, Oerline M, Carlin AM, Nunn AR, Dimick J, Banerjee M, Birkmeyer NJ, Michigan Bariatric Surgery Collaborative. Surgical skill and complication rates after bariatric surgery. *N Engl J Med*. 2013;369:1434–42.
- Bjorntorp P. Metabolic implications of body-fat distribution. *Diabetes Care*. 1991;14:1132–43.
- Blüher M. Adipose tissue dysfunction in obesity. *Exp Clin Endocrinol Diabetes*. 2009;117:241–50.

- Blüher M. Adipose tissue dysfunction contributes to obesity related metabolic diseases. *Best Pract Res Clin Endocrinol Metab.* 2013;27:163–77.
- Blüher M. Adipose tissue inflammation: a cause or consequence of obesity-related insulin resistance? *Clin Sci (Lond).* 2016;130:1603–14.
- Boden G, Shulman GI. Free fatty acids in obesity and type 2 diabetes: defining their role in the development of insulin resistance and  $\beta$ -cell dysfunction. *Eur J Clin Invest.* 2002;32:14–23.
- Bray GA, Frühbeck G, Ryan DH, Wilding JP. Management of obesity. *Lancet.* 2016;387:1947–56.
- Brunzell JD, Robertson RP, Lerner RL, Hazzard WR, Ensnick JW, Bierman EL, Porte D Jr. Relationships between fasting plasma glucose levels and insulin secretion during intravenous glucose tolerance tests. *J Clin Endocrinol Metab.* 1976;42:222–9.
- Buchwald H, Estok R, Fahrenbach K, Banel D, Jensen MD, Pories WJ, et al. Weight and type 2 diabetes after bariatric surgery: systematic review and meta-analysis. *Am J Med.* 2009;122:248–56.
- Cancello R, Henegar C, Viguier N, Taleb S, Poitou C, Rouault C, Coupaye M, Pelloux V, Hugol D, Bouillot JL, Bouloumié A, Barbatelli G, Cinti S, Svensson PA, Barsh GS, Zucker JD, Basdevant A, Langin D, Clément K. Reduction of macrophage infiltration and chemoattractant gene expression changes in white adipose tissue of morbidly obese subjects after surgery-induced weight loss. *Diabetes.* 2005;54:2277–86.
- Chang SH, Stoll CR, Song J, Varela JE, Eagon CJ, Colditz GA. The effectiveness and risks of bariatric surgery: an updated systematic review and meta-analysis, 2003–2012. *JAMA Surg.* 2014;149:275–87.
- Cinti S. The adipose organ at a glance. *Dis Model Mech.* 2012;5:588–94.
- Cinti S, Mitchell G, Barbatelli G, Murano I, Ceresi E, Faloia E, Wang S, Fortier M, Greenberg AS, Obin MS. Adipocyte death defines macrophage localization and function in adipose tissue of obese mice and humans. *J Lipid Res.* 2005;46:2347–55.
- Cohen P, Spiegelman BM. Brown and beige fat: molecular parts of a thermogenic machine. *Diabetes.* 2015;64:2346–51.
- Colditz GA, Willett WC, Rotnitzky A, Manson JE. Weight gain as a risk factor for clinical diabetes mellitus in women. *Ann Intern Med.* 1995;122:481–6.
- Cypess AM, Lehman S, Williams G, Tal I, Rodman D, Goldfine AB, Kuo FC, Palmer EL, Tseng YH, Doria A, Kolodny GM, Kahn CR. Identification and importance of brown adipose tissue in adult humans. *N Engl J Med.* 2009;360:1509–17.
- DeFronzo RA. Insulin resistance, lipotoxicity, type 2 diabetes and atherosclerosis: the missing links. The Claude Bernard Lecture 2009. *Diabetologia.* 2010;53:1270–87.
- Despres JP, Nadeau A, Tremblay A, et al. Role of deep abdominal fat in the association between regional adipose tissue distribution and glucose tolerance in obese women. *Diabetes.* 1989;38:304–9.
- Drucker DJ, Nauck MA. The incretin system: glucagon-like-peptide-1 receptor agonists and dipeptidyl peptidase-4 inhibitors in type 2 diabetes. *Lancet.* 2006;368:1696–705.
- Farooqi IS, et al. Effects of recombinant leptin therapy in a child with congenital leptin deficiency. *N Engl J Med.* 1999;341:879–84.
- Fasshauer M, Blüher M. Adipokines in health and disease. *Trends Pharmacol Sci.* 2015;36(7):461–70. <https://doi.org/10.1016/j.tips.2015.04.014>.
- Foster MC, Hwang SJ, Porter SA, Massaro JM, Hoffmann U, Fox CS. Fatty kidney, hypertension, and chronic kidney disease: the Framingham Heart Study. *Hypertension.* 2011;58:784–90.
- Franks PW, McCarthy MI. Exposing the exposures responsible for type 2 diabetes and obesity. *Science.* 2016;354:69–73.
- Frayling TM, Timpson NJ, Weedon MN, Zeggini E, Freathy RM, Lindgren CM, et al. A common variant in the FTO gene is associated with body mass index and predisposes to childhood and adult obesity. *Science.* 2007;316:889–94.
- Gadde KM, Allison DB, Ryan DH, et al. Effects of low-dose, controlled-release, phentermine plus topiramate combination on weight and associated comorbidities in overweight and obese adults (CONQUER): a randomised, placebo-controlled, phase 3 trial. *Lancet.* 2011;377:1341–52.

- GBD 2013 Mortality and Causes of Death Collaborators. Global, regional, and national age-sex specific all-cause and cause-specific mortality for 240 causes of death, 1990-2013: a systematic analysis for the Global Burden of Disease Study 2013. *Lancet*. 2015;385:117-71.
- Gloyn AL, Weedon MN, Owen KR, et al. Large-scale association studies of variants in genes encoding the pancreatic beta-cell KATP channel subunits Kir6.2 (KCNJ11) and SUR1 (ABCC8) confirm that the KCNJ11 E23K variant is associated with type 2 diabetes. *Diabetes*. 2003;52:568-72.
- Goldstein BJ. Protein-tyrosine phosphatases and the regulation of insulin action. In: LeRoith D, Taylor SI, Olefsky JM, editors. *Diabetes mellitus: a fundamental and clinical text*. Philadelphia: Lippincott; 2003. p. 255-68.
- Greenberg I, Stampfer MJ, Schwarzfuchs D, Shai I, DIRECT Group. Adherence and success in long-term weight loss diets: the dietary intervention randomized controlled trial (DIRECT). *J Am Coll Nutr*. 2009;28(2):159-68.
- Gudzune KA, Doshi RS, Mehta AK, et al. Efficacy of commercial weight-loss programs: an updated systematic review. *Ann Intern Med*. 2015;162:501-12.
- Haase J, Weyer U, Immig K, Klötting N, Blüher M, Eilers J, Bechmann I, Gericke M. Local proliferation of macrophages in adipose tissue during obesity-induced inflammation. *Diabetologia*. 2014;57:562-71.
- Hauer H. Diabetes and obesity. In: Holt RIG, Cockram CS, Flyvbjerg A, Goldstein BJ (eds), *Textbook of diabetes*. 4th edition. Blackwell, Chichester, UK; 2010. ISBN 978-1-405-19181-4.
- Hu T, Mills KT, Yao L, et al. Effects of low-carbohydrate diets versus low-fat diets on metabolic risk factors: a meta-analysis of randomized controlled clinical trials. *Am J Epidemiol*. 2012;176: S44-54.
- Huo R, Du T, Xu Y, et al. Effects of Mediterranean-style diet on glycemic control, weight loss and cardiovascular risk factors among type 2 diabetes individuals: a meta-analysis. *Eur J Clin Nutr*. 2014;69:1200-8.
- Jakicic JM, Egan CM, Fabricatore AN, Look AHEAD Research Group, et al. Four-year change in cardiorespiratory fitness and influence on glycemic control in adults with type 2 diabetes in a randomized trial: the Look AHEAD trial. *Diabetes Care*. 2013;36:1297-303.
- Johnston BC, Kanters S, Bandyrel K, Wu P, Naji F, Siemieniuk RA, Ball GD, Busse JW, Thorlund K, Guyatt G, Jansen JP, Mills EJ. Comparison of weight loss among named diet programs in overweight and obese adults: a meta-analysis. *JAMA*. 2014;312:923-33.
- Klein S, Fontana L, Young VL, et al. Absence of an effect of liposuction on insulin action and risk factors for coronary heart disease. *N Engl J Med*. 2004;350:2549-57.
- Klötting N, Fasshauer M, Dietrich A, Kovacs P, Schön MR, Kern M, Stumvoll M, Blüher M. Insulin-sensitive obesity. *Am J Physiol Endocrinol Metab*. 2010;299:E506-15.
- Knowler WC, Fowler SE, Hamman RF, Diabetes Prevention Program Research Group, et al. 10-year follow-up of diabetes incidence and weight loss in the Diabetes Prevention Program Outcomes Study. *Lancet*. 2009;374:1677-86.
- Konrad D, Rudich A, Schoenle EJ. Improved glucose tolerance in mice receiving intraperitoneal transplantation of normal fat tissue. *Diabetologia*. 2007;50:833-9.
- Kühnen P, Clément K, Wiegand S, Blankenstein O, Gottesdiener K, Martini LL, Mai K, Blume-Peytavi U, Grüters A, Krude H. Proopiomelanocortin deficiency treated with a melanocortin-4 receptor agonist. *N Engl J Med*. 2016;375:240-6.
- Lebovitz HE. Insulin resistance: definition and consequences. *Exp Clin Endocrinol Diabetes*. 2001;109:S135-48.
- LeFevre ML, U.S. Preventive Services Task Force. Behavioral counseling to promote a healthful diet and physical activity for cardiovascular disease prevention in adults with cardiovascular risk factors: U.S. Preventive Services Task Force Recommendation Statement. *Ann Intern Med*. 2014;161:587-93.
- Li SX, Imamura F, Ye Z, Schulze MB, Zheng J, Ardanaz E, Arriola L, Boeing H, Dow C, Fagherazzi G, Franks PW, Agudo A, Grioni S, Kaaks R, Katzke VA, Key TJ, Khaw KT, Mancini FR, Navarro C, Nilsson PM, Onland-Moret NC, Overvad K, Palli D, Panico S,

- Quirós JR, Rolandsson O, Sacerdote C, Sánchez MJ, Slimani N, Sluijs I, Spijkerman AM, Tjønneland A, Tumino R, Sharp SJ, Riboli E, Langenberg C, Scott RA, Forouhi NG, Wareham NJ. Interaction between genes and macronutrient intake on the risk of developing type 2 diabetes: systematic review and findings from European Prospective Investigation into Cancer (EPIC)-InterAct. *Am J Clin Nutr*. 2017. <https://doi.org/10.3945/ajcn.116.150094>. pii: ajcn150094.
- Look AHEAD Research Group, Wing RR, Bolin P, Brancati FL, Bray GA, Clark JM, Coday M, Crow RS, Curtis JM, Egan CM, Espeland MA, Evans M, Foreyt JP, Ghazarian S, Gregg EW, Harrison B, Hazuda HP, Hill JO, Horton ES, Hubbard VS, Jakicic JM, Jeffery RW, Johnson KC, Kahn SE, Kitabchi AE, Knowler WC, Lewis CE, Maschak-Carey BJ, Montez MG, Murillo A, Nathan DM, Patricio J, Peters A, Pi-Sunyer X, Pownall H, Reboussin D, Regensteiner JG, Rickman AD, Ryan DH, Safford M, Wadden TA, Wagenknecht LE, West DS, Williamson DF, Yanovski SZ. Cardiovascular effects of intensive lifestyle intervention in type 2 diabetes. *N Engl J Med*. 2013;369(2):145–54. <https://doi.org/10.1056/NEJMoa1212914>.
- Mingrone G, Panunzi S, De Gaetano A, Guidone C, Iaconelli A, Leccesi L, Nanni G, Pomp A, Castagneto M, Ghirlanda G, Rubino F. Bariatric surgery versus conventional medical therapy for type 2 diabetes. *N Engl J Med*. 2012;366:1577–85.
- Moitra J, Mason MM, Olive M, Krylov D, Gavrilova O, Marcus-Samuels B, Feigenbaum L, Lee E, Aoyama T, Eckhaus M, Reitman ML, Vinson C. Life without white fat: a transgenic mouse. *Genes Dev*. 1998;12:3168–81.
- Narayan KM, Boyle JP, Thompson TJ, Sorensen SW, Williamson DF. Lifetime risk for diabetes mellitus in the United States. *JAMA*. 2003;290:1884–90.
- National Institute for Health and Clinical Excellence: Guidance. Obesity: identification, assessment and management of overweight and obesity in children, young people and adults: partial update of CG43, National Clinical Guideline Centre (UK). London: National Institute for Health and Care Excellence (UK); 2014.
- National Task Force on the Prevention and Treatment of Obesity. Long-term pharmacotherapy in the management of obesity. *JAMA*. 1996;276:1907–15.
- Ng M, Fleming T, Robinson M, Thomson B, Graetz N, Margono C, Mullany EC, Biryukov S, Abbafati C, Abera SF, Abraham JP, Abu-Rmeileh NM, Achoki T, AlBuhairan FS, Alemu ZA, Alfonso R, Ali MK, Ali R, Guzman NA, Ammar W, Anwar P, Banerjee A, Barquera S, Basu S, Bennett DA, Bhutta ZA, Blore J, Cabral N, Nonato IC, Chang JC, Chowdhury R, Courville KJ, Criqui MH, Cundiff DK, Dabhadkar KC, Dandona L, Davis A, Dayama A, Dharmaratne SD, Ding EL, Durrani AM, Esteghamati A, Farzadfar F, Fay DF, Feigin VL, Flaxman A, Forouzanfar MH, Goto A, Green MA, Gupta R, Hafezi-Nejad N, Hankey GJ, Harewood HC, Havmoeller R, Hay S, Hernandez L, Husseini A, Idrisov BT, Ikeda N, Islami F, Jahangir E, Jassal SK, Jee SH, Jeffreys M, Jonas JB, Kabagambe EK, Khalifa SE, Kengne AP, Khader YS, Khang YH, Kim D, Kimokoti RW, Kinge JM, Kokubo Y, Kosen S, Kwan G, Lai T, Leinsalu M, Li Y, Liang X, Liu S, Logroscino G, Lotufo PA, Lu Y, Ma J, Mainoo NK, Mensah GA, Merriman TR, Mokdad AH, Moschandreas J, Naghavi M, Naheed A, Nand D, Narayan KM, Nelson EL, Neuhouser ML, Nisar MI, Ohkubo T, Oti SO, Pedroza A, Prabhakaran D, Roy N, Sampson U, Seo H, Sepanlou SG, Shibuya K, Shiri R, Shiue I, Singh GM, Singh JA, Skirbekk V, Stapelberg NJ, Sturua L, Sykes BL, Tobias M, Tran BX, Trasande L, Toyoshima H, van de Vijver S, Vasankari TJ, Veerman JL, Velasquez-Melendez G, Vlassov VV, Vollset SE, Vos T, Wang C, Wang X, Weiderpass E, Werdecker A, Wright JL, Yang YC, Yatsuya H, Yoon J, Yoon SJ, Zhao Y, Zhou M, Zhu S, Lopez AD, Murray CJ, Gakidou E. Global, regional, and national prevalence of overweight and obesity in children and adults during 1980–2013: a systematic analysis for the Global Burden of Disease Study 2013. *Lancet*. 2014;384:766–81.
- Norris SL, Zhang X, Avenell A, Gregg E, Schmid CH, Lau J. Pharmacotherapy for weight loss in adults with type 2 diabetes mellitus. *Cochrane Database Syst Rev*. 2005;1:CD004096.
- Padwal RS, Pajewski NM, Allison DB, Sharma AM. Using the Edmonton obesity staging system to predict mortality in a population-representative cohort of people with overweight and obesity. *CMAJ*. 2011;183(14):E1059–66. <https://doi.org/10.1503/cmaj.110387>.

- Paffenbarger RS Jr, Hyde RT, Wing AL, Hsieh CC. Physical activity, all-cause mortality, and longevity of college alumni. *N Engl J Med.* 1986;314:605–13.
- Pi-Sunyer X, Astrup A, Fujioka K, Greenway F, Halpern A, Krepf M, Lau DC, le Roux CW, Violante Ortiz R, Jensen CB, Wilding JP, SCALE Obesity and Prediabetes NN8022-1839 Study Group. A randomized, controlled trial of 3.0 mg of liraglutide in weight management. *N Engl J Med.* 2015;373:11–22.
- Porzio O, Federici M, Hribal ML, et al. The Gly972→Arg amino acid polymorphism in IRS-1 impairs insulin secretion in pancreatic beta cells. *J Clin Invest.* 1999;104:357–64.
- Purnell JQ, Hokanson JE, Marcovina SM, Steffes MW, Cleary PA, Brunzell JD. Effect of excessive weight gain with intensive therapy of type 1 diabetes on lipid levels and blood pressure: results from the DCCT. *JAMA.* 1998;280:140–6.
- Ravussin E, Lillioja S, Knowler WC, Christin L, Freymond D, Abbott WG, et al. Reduced rate of energy expenditure as a risk factor for body weight gain. *N Engl J Med.* 1988;318:467–72.
- Robbins AL, Savage DB. The genetics of lipid storage and human lipodystrophies. *Trends Mol Med.* 2015;21:433–8.
- Robertson RP, Harmon J, Tran PO, Tanaka Y, Takahashi H. Glucose toxicity in beta-cells: type 2 diabetes, good radicals gone bad, and the glutathione connection. *Diabetes.* 2003;52:581–7.
- Rubino F, Nathan DM, Eckel RH, Schauer PR, Alberti KG, Zimmet PZ, Del Prato S, Ji L, Sadikot SM, Herman WH, Amiel SA, Kaplan LM, Taroncher-Oldenburg G, Cummings DE, Delegates of the 2nd Diabetes Surgery Summit. Metabolic surgery in the treatment algorithm for type 2 diabetes: a joint statement by international diabetes organizations. *Diabetes Care.* 2016;39:861–77.
- Ryan D, Heaner M. Guidelines (2013) for managing overweight and obesity in adults. Preface to the full report. *Obesity (Silver Spring).* 2014;22(suppl 2):S1–3.
- Sacks FM, Bray GA, Carey VJ, Smith SR, Ryan DH, Anton SD, McManus K, Champagne CM, Bishop LM, Laranjo N, Leboff MS, Rood JC, de Jonge L, Greenway FL, Loria CM, Obarzanek E, Williamson DA. Comparison of weight-loss diets with different compositions of fat, protein, and carbohydrates. *N Engl J Med.* 2009;360:859–73.
- Schauer PR, Kashyap SR, Wolski K, Brethauer SA, Kirwan JP, Pothier CE, Thomas S, Abood B, Nissen SE, Bhatt DL. Bariatric surgery versus intensive medical therapy in obese patients with diabetes. *N Engl J Med.* 2012;366:1567–76.
- Schauer PR, Bhatt DL, Kirwan JP, Wolski K, Brethauer SA, Navaneethan SD, Aminian A, Pothier CE, Kim ES, Nissen SE, Kashyap SR, STAMPEDE Investigators. Bariatric surgery versus intensive medical therapy for diabetes – 3-year outcomes. *N Engl J Med.* 2014;370:2002–13.
- Schleinitz D, Böttcher Y, Blüher M, Kovacs P. The genetics of fat distribution. *Diabetologia.* 2014;57:1276–86.
- Schwartz MW, Woods SC, Porte D Jr, Seeley RJ, Baskin DG. Central nervous system control of food intake. *Nature.* 2000;404:661–71.
- Scott RA, Scott LJ, Mägi R, Marullo L, Gaulton KJ, Kaakinen M, Pervjakova N, Pers TH, Johnson AD, Eicher JD, Jackson AU, Ferreira T, Lee Y, Ma C, Steinthorsdottir V, Thorleifsson G, Qi L, Van Zuydam NR, Mahajan A, Chen H, Almgren P, Voight BF, Grallert H, Müller-Nurasyid M, Ried JS, Rayner WN, Robertson N, Karssen LC, van Leeuwen EM, Willems SM, Fuchsberger C, Kwan P, Teslovich TM, Chanda P, Li M, Lu Y, Dina C, Thuillier D, Yengo L, Jiang L, Sparso T, Kestler HA, Chheda H, Eisele L, Gustafsson S, Frånberg M, Strawbridge RJ, Benediktsson R, Hreidarsson AB, Kong A, Sigurðsson G, Kerrison ND, Luan J, Liang L, Meitinger T, Roden M, Thorand B, Esko T, Mihailov E, Fox C, Liu CT, Rybin D, Isomaa B, Lyssenko V, Tuomi T, Couper DJ, Pankow JS, Grarup N, Have CT, Jørgensen ME, Jørgensen T, Linneberg A, Cornelis MC, van Dam RM, Hunter DJ, Kraft P, Sun Q, Edkins S, Owen KR, Perry JR, Wood AR, Zeggini E, Tajas-Fernandes J, Abecasis GR, Bonnycastle LL, Chines PS, Stringham HM, Koistinen HA, Kinnunen L, Sennblad B, Mühleisen TW, Nöthen MM, Pechlivanis S, Baldassarre D, Gertow K, Humphries SE, Tremoli E, Klopp N, Meyer J, Steinbach G, Wennauer R, Eriksson JG, Männistö S, Peltonen L, Tikkanen E, Charpentier G, Eury E, Lobbens S, Gigante B, Leander K, McLeod O, Bottinger EP, Gottesman O, Ruderfer D, Blüher M, Kovacs P, Tonjes A, Maruthur NM, Scapoli C, Erbel R, Jöckel KH, Moebus S, de Faire U, Hamsten A, Stumvoll M, Deloukas P, Donnelly PJ, Frayling TM, Hattersley AT, Ripatti S, Salomaa V, Pedersen NL, Boehm BO, Bergman RN, Collins FS, Mohlke KL, Tuomilehto

- J, Hansen T, Pedersen O, Barroso I, Lannfelt L, Ingelsson E, Lind L, Lindgren CM, Cauchi S, Froguel P, Loos RJ, Balkau B, Boeing H, Franks PW, Gurea AB, Palli D, van der Schouw YT, Altshuler D, Groop LC, Langenberg C, Wareham NJ, Sijbrands E, van Duijn CM, Florez JC, Meigs JB, Boerwinkle E, Gieger C, Strauch K, Metspalu A, Morris AD, Palmer CN, Hu FB, Thorsteinsdottir U, Stefansson K, Dupuis J, Morris AP, Boehnke M, McCarthy MI, Prokopenko I, DIAbetes Genetics Replication And Meta-analysis (DIAGRAM) Consortium. An expanded genome-wide association study of type 2 diabetes in Europeans. *Diabetes*. 2017. <https://doi.org/10.2337/db16-1253>. pii: db161253.
- Sell H, Habich C, Eckel J. Adaptive immunity in obesity and insulin resistance. *Nat Rev Endocrinol*. 2012;8:709–16.
- Shai I, Schwarzfuchs D, Henkin Y, Shahar DR, Witkow S, Greenberg I, Golan R, Fraser D, Bolotin A, Vardi H, Tangi-Rozental O, Zuk-Ramot R, Sarusi B, Brickner D, Schwartz Z, Sheiner E, Marko R, Katorza E, Thiery J, Fiedler GM, Blüher M, Stumvoll M, Stampfer MJ, Dietary Intervention Randomized Controlled Trial (DIRECT) Group. Weight loss with a low-carbohydrate, Mediterranean, or low-fat diet. *N Engl J Med*. 2008;359:229–41.
- Sharma AM, Kushner RF. A proposed clinical staging system for obesity. *Int J Obes*. 2009;33(3):289–95. <https://doi.org/10.1038/ijo.2009.2>
- Sjöström L, Narbro K, Sjöström CD, Karason K, Larsson B, Wedel H, et al. Effects of bariatric surgery on mortality in Swedish obese subjects. *N Engl J Med*. 2007;357:741–52.
- Sjöström L, Peltonen M, Jacobson P, et al. Bariatric surgery and long-term cardiovascular events. *JAMA*. 2012;307:56–65.
- Smith SR, Weissman NJ, Anderson CM, Behavioral Modification and Lorcaserin for Overweight and Obesity Management (BLOOM) Study Group, et al. Multicenter, placebo-controlled trial of lorcaserin for weight management. *N Engl J Med*. 2010;363:245–56.
- Spalding KL, Arner E, Westermark PO, Bernard S, Buchholz BA, Bergmann O, Blomqvist L, Hoffstedt J, Näslund E, Britton T, Concha H, Hassan M, Rydén M, Frisén J, Arner P. Dynamics of fat cell turnover in humans. *Nature*. 2008;453:783–7.
- Speliotes EK, Massaro JM, Hoffmann U, et al. Fatty liver is associated with dyslipidemia and dysglycemia independent of visceral fat: the Framingham Heart Study. *Hepatology*. 2010;51:1979–87.
- Stumvoll M, Goldstein BJ, van Haefen TW. Type 2 diabetes: principles of pathogenesis and therapy. *Lancet*. 2005;365:1333–46.
- Stunkard AJ, Foch TT, Hrubec Z. A twin study of human obesity. *JAMA*. 1986a;256:51–4.
- Stunkard AJ, Sorensen TI, Hanis C, Teasdale TW, Chakraborty R, Schull WJ, et al. An adoption study of human obesity. *N Engl J Med*. 1986b;314:193–8.
- Swinburn BA, Sacks G, Hall KD, McPherson K, Finegood DT, Moodie ML, Gortmaker SL. The global obesity pandemic: shaped by global drivers and local environments. *Lancet*. 2011;378:804–14.
- Tack J, DeLoose E. Complications of bariatric surgery: dumping syndrome, reflux and vitamin deficiencies. *Best Pract Res Clin Gastroenterol*. 2014;28:741–9.
- Tham JC, Howes N, le Roux CW. The role of bariatric surgery in the treatment of diabetes. *Ther Adv Chronic Dis*. 2014;5:149–57.
- Thorne A, Lonnqvist F, Apelman J, Hellers G, Arner P. A pilot study of long-term effects of a novel obesity treatment: omentectomy in connection with adjustable gastric banding. *Int J Obes Relat Metab Disord*. 2002;26:193–9.
- Torgerson JS, Hauptman J, Boldrin MN, Sjöström L. XENical in the prevention of diabetes in obese subjects (XENDOS) study: a randomized study of orlistat as an adjunct to lifestyle changes for the prevention of type 2 diabetes in obese patients. *Diabetes Care*. 2004;27:155–61.
- Tran TT, Yamamoto Y, Gesta S, Kahn CR. Beneficial effects of subcutaneous fat transplantation on metabolism. *Cell Metab*. 2008;7:410–20.
- UKPDS. Intensive blood-glucose control with sulphonylureas or insulin compared with conventional treatment and risk of complications in patients with type 2 diabetes (UKPDS 33). *Lancet*. 1998;12:837–52.
- Unick JL, Neiberg RH, Hogan PE, Look AHEAD Research Group, et al. Weight change in the first 2 months of a lifestyle intervention predicts weight changes 8 years later. *Obesity (Silver Spring)*. 2015;23:1353–6.



- van Marken Lichtenbelt WD, Vanhommerig JW, Smulders NM, Drossaerts JM, Kemerink GJ, Bouvy ND, Schrauwen P, Teule GJ. Cold-activated brown adipose tissue in healthy men. *N Engl J Med*. 2009;360:1500–8.
- Waldén TB, Hansen IR, Timmons JA, Cannon B, Nedergaard J. Recruited vs. nonrecruited molecular signatures of brown, “brite,” and white adipose tissues. *Am J Physiol Endocrinol Metab*. 2012;302:E19–31.
- Wardle J, Carnell S, Haworth CM, Plomin R. Evidence for a strong genetic influence on childhood obesity despite the force of the obesogenic environment. *Am J Clin Nutr*. 2008;87:398–404.
- Wei M, Kampert JB, Barlow CE, Nichaman MZ, Gibbons LW, Paffenbarger RS Jr, Blair SN. Relationship between low cardiorespiratory fitness and mortality in normal-weight, overweight, and obese men. *JAMA*. 1999;282:1547–53.
- Weisberg SP, McCann D, Desai M, Rosenbaum M, Leibel RL, Ferrante AW Jr. Obesity is associated with macrophage accumulation in adipose tissue. *J Clin Invest*. 2003;112:1796–808.
- White MF. IRS proteins and the common path to diabetes. *Am J Physiol Endocrinol Metab*. 2002;283:E413–22.
- WHO Expert Committee on Definition. Diagnosis and classification of diabetes mellitus and its complications. Geneva: World Health Organisation; 1999. p. 1–59.
- WHO fact sheet. 2016. <http://www.who.int/mediacentre/factsheets/fs311/en/>
- Wu T, Gao X, Chen M, van Dam RM. Long-term effectiveness of diet-plus-exercise interventions versus diet-only interventions for weight loss: a meta-analysis. *Obes Rev*. 2009;10:313–23.
- Zhang Y, et al. Positional cloning of the mouse obese gene and its human homologue. *Nature*. 1994;372:425–32.
- Zhou B, Lu Y, Hajifathalian K, Bentham J, Di Cesare M, Danaei G, Bixby H, Cowan MJ, Ali MK, Taddei C, Lo WC, Reis-Santos B, Stevens GA, Riley LM, Miranda JJ, Bjerregaard P, Rivera JA, Fouad HM, Ma G, Mbanya JC, McGarvey ST, Mohan V, Onat A, Pilav A, Ramachandran A, Romdhane HB, Pacionek CJ, Bennett JE, Ezzati M, Abdeen ZA, Abdul Kadir K, Abu-Rmeileh NM, Acosta-Cazares B, Adams R, Aekplakorn W, Aguilar-Salinas CA, Agyemang C, Ahmadvand A, Al-Othman AR, Alkerwi A, Amouyel P, Amuzu A, Andersen LB, Anderssen SA, Anjana RM, Aounallah-Skhiri H, Aris T, Arlappa N, Arveiler D, Assah FK, Avdicová M, Azizi F, Balakrishna N, Bandosz P, Barbagallo CM, Barceló A, Batieha AM, Baur LA, Romdhane HB, Benet M, Bernabe-Ortiz A, Bharadwaj S, Bhargava SK, Bi Y, Bjerregaard P, Bjertness E, Bjertness MB, Björkelund C, Blokstra A, Bo S, Boehm BO, Boissonnet CP, Bovet P, Brajkovich I, Breckenkamp J, Brenner H, Brewster LM, Brian GR, Bruno G, Bugge A, Cabrera de León A, Can G, Cândido AP, Capuano V, Carlsson AC, Carvalho MJ, Casanueva FF, Casas JP, Caserta CA, Castetbon K, Chamukuttan S, Chaturvedi N, Chen CJ, Chen F, Chen S, Cheng CY, Chetrit A, Chiou ST, Cho Y, Chudek J, Cifkova R, Claessens F, Concin H, Cooper C, Cooper R, Costanzo S, Cottel D, Cowell C, Crujeiras AB, D’Arrigo G, Dallongeville J, Dankner R, Dauchet L, de Gaetano G, De Henauw S, Deepa M, Dehghan A, Deschamps V, Dhana K, Di Castelnuovo AF, Djalalinia S, Doua K, Drygas W, Du Y, Dzerve V, Egbagbe EE, Eggertsen R, El Ati J, Elosua R, Erasmus RT, Erem C, Ergor G, Eriksen L, Escobedo-de la Peña J, Fall CH, Farzadfar F, Felix-Redondo FJ, Ferguson TS, Fernández-Bergés D, Ferrari M, Ferreccio C, Feskens EJ, Finn JD, Föger B, Foo LH, Forslund AS, Fouad HM, Francis DK, Franco Mdo C, Franco OH, Frontera G, Furusawa T, Gaciong Z, Garnett SP, Gaspoz JM, Gasull M, Gates L, Geleijnse JM, Ghasemian A, Ghimire A, Giampaoli S, Gianfagna F, Giovannelli J, Giwerzman A, Gross MG, González Rivas JP, Gorbea MB, Gottrand F, Grafnetter D, Grodzicki T, Grøntved A, Gruden G, Gu D, Guan OP, Guerrero R, Guessous I, Guimaraes AL, Gutierrez L, Hambleton IR, Hardy R, Hari Kumar R, Hata J, He J, Heidemann C, Herrala S, Hihtaniemi IT, Ho SY, Ho SC, Hofman A, Hormiga CM, Horta BL, Houti L, Howitt C, Htay TT, Htet AS, Htike MM, Hu Y, Hussieni AS, Huybrechts I, Hwalla N, Iacoviello L, Iannone AG, Ibrahim MM, Ikeda N, Ikram MA, Irazola VE, Islam M, Iwasaki M, Jacobs JM, Jafar T, Jamil KM, Jasienska G, Jiang CQ, Jonas JB, Joshi P, Kafatos A, Kalter-Leibovici O, Kasaeian A, Katz J, Kaur P, Kavousi M, Keinänen-Kiukkaanniemi S, Kelishadi R, Kengne AP, Kersting M, Khader YS, Khalili D, Khang YH, Kiechl S, Kim J, Kolsteren P, Korrovtis P, Kratzer W, Kromhout D, Kujala UM, Kula K,

Kyobutungi C, Laatikainen T, Lachat C, Laid Y, Lam TH, Landrove O, Lanska V, Lappas G, Laxmaiah A, Leclercq C, Lee J, Lee J, Lehtimäki T, Lekhraj R, León-Muñoz LM, Li Y, Lim WY, Lima-Costa MF, Lin HH, Lin X, Lissner L, Lorbeer R, Lozano JE, Luksiene D, Lundqvist A, Lytsy P, Ma G, Machado-Coelho GL, Machi S, Maggi S, Magliano DJ, Makdisse M, Mallikharjuna Rao K, Manios Y, Manzano E, Margozzini P, Marques-Vidal P, Martorell R, Masoodi SR, Mathiesen EB, Matsha TE, Mbanya JC, McFarlane SR, McGarvey ST, McLachlan S, McNulty BA, Mediene-Benchekor S, Meirhaeghe A, Menezes AM, Merat S, Meshram II, Mi J, Miquel JF, Miranda JJ, Mohamed MK, Mohammad K, Mohammadifard N, Mohan V, Mohd Yusoff MF, Møller NC, Molnár D, Mondo CK, Morejon A, Moreno LA, Morgan K, Moschonis G, Mossakowska M, Mostafa A, Mota J, Motta J, Mu TT, Muijesan ML, Müller-Nurasyid M, Mursu J, Nagel G, Námešná J, Nang EE, NangThetia VB, Navarrete-Muñoz EM, Ndiaye NC, Nenko I, Nervi F, Nguyen ND, Nguyen QN, Nieto-Martínez RE, Ning G, Ninomiya T, Noale M, Noto D, Nsour MA, Ochoa-Avilés AM, Oh K, Onat A, Ordunez P, Osmond C, Otero JA, Owusu-Dabo E, Pahomova E, Palmieri L, Panda-Jonas S, Panza F, Parsaeian M, Peixoto SV, Peltonen M, Peters A, Peykari N, Pham ST, Pilav A, Pitakaka F, Piwonska A, Piwonski J, Plans-Rubió P, Porta M, Portegies ML, Poustchi H, Pradeepa R, Price JF, Punab M, Qasrawi RF, Qorbani M, Radisauskas R, Rahman M, Raitakari O, Rao SR, Ramachandran A, Ramke J, Ramos R, Rampal S, Rathmann W, Redon J, Reganit PF, Rigo F, Robinson SM, Robitaille C, Rodriguez-Artalejo F, Rodriguez-Perez Mdel C, Rodríguez-Villamizar LA, Rojas-Martinez R, Ronkainen K, Rosengren A, Rubinstein A, Rui O, Ruiz-Betancourt BS, Russo Horimoto RV, Rutkowski M, Sabanayagam C, Sachdev HS, Saidi O, Sakarya S, Salanave B, Salonen JT, Salvetti M, Sánchez-Abanto J, Santos D, dos Santos RN, Santos R, Saramies JL, Sardinha LB, Sarrafzadegan N, Saum KU, Scazufca M, Scharngrotsky H, Scheidt-Nave C, Sein AA, Sharma SK, Shaw JE, Shibuya K, Shin Y, Shiri R, Siantar R, Sibai AM, Simon M, Simons J, Simons LA, Sjoström M, Slowikowska-Hilczer J, Slusarczyk P, Smeeth L, Snijder MB, So HK, Sobngwi E, Söderberg S, Solfrizzi V, Sonestedt E, Soumare A, Staessen JA, Stathopoulou MG, Steene-Johannessen J, Stehle P, Stein AD, Stessman J, Stöckl D, Stokwizewski J, Stronks K, Strufaldi MW, Sun CA, Sundström J, Sung YT, Suriyawongpaisal P, Sy RG, Tai ES, Tamosiunas A, Tang L, Tarawneh M, Tarqui-Mamani CB, Taylor A, Theobald H, Thijs L, Thuesen BH, Tolonen HK, Tolstrup JS, Topbas M, Torrent M, Traissac P, Trinh OT, Tulloch-Reid MK, Tuomainen TP, Turley ML, Tzourio C, Ueda P, Ukoli FA, Ulmer H, Uusitalo HM, Valdivia G, Valvi D, van Rossem L, van Valkengoed IG, Vanderschueren D, Vanuzzo D, Vega T, Velasquez-Melendez G, Veronesi G, Verschuren WM, Verstraeten R, Viet L, Vioque J, Virtanen JK, Visvikis-Siest S, Viswanathan B, Vollenweider P, Voutilainen S, Vrijheid M, Wade AN, Wagner A, Walton J, Wan Mohamud WN, Wang F, Wang MD, Wang Q, Wang YX, Wannamethee SG, Weerasekera D, Whincup PH, Widhalm K, Wiecek A, Wijga AH, Wilks RJ, Willeit J, Wilsgaard T, Wojtyniak B, Wong TY, Woo J, Woodward M, Wu FC, Wu SL, Xu H, Yan W, Yang X, Ye X, Yoshihara A, Younger-Coleman NO, Zambon S, Zargar AH, Zdrojewski T, Zhao W, Zheng Y, Zúñiga Cisneros J. Worldwide trends in diabetes since 1980: a pooled analysis of 751 population-based studies with 4.4 million participants. *Lancet*. 2016;387:1513–30.



# Diabetes and Dyslipidemia

# 2

Henry N. Ginsberg, Maryam Khavandi, and Gisette Reyes-Soffer

## Contents

Introduction .....	52
Lipoprotein Composition .....	53
Transport of Dietary Lipids on apo B48-Containing Lipoproteins in Diabetes Mellitus .....	55
Transport of Endogenous Lipids on apo B100-Containing Lipoproteins in Diabetes Mellitus .....	56
VLDL .....	56
LDL .....	59
Transport of apo A-Containing Lipoproteins in Diabetes Mellitus .....	60
HDL .....	60
Treatment of Diabetic Dyslipidemia .....	61
Nonpharmacologic Therapies .....	61
Lipid Lowering Therapies .....	63
Current Treatment Guidelines .....	63
Statins .....	63
Summary .....	66
References .....	66

---

H. N. Ginsberg (✉)

Department of Medicine, Irving Institute for Clinical and Translational Research, Columbia University Vagelos College of Physicians and Surgeons, New York, NY, USA

e-mail: [hng1@cumc.columbia.edu](mailto:hng1@cumc.columbia.edu)

M. Khavandi

Department of Medicine, Bassett Medical Center, New York, NY, USA

e-mail: [maryam.khavandi@gmail.com](mailto:maryam.khavandi@gmail.com)

G. Reyes-Soffer

Department of Medicine, Columbia University Vagelos College of Physicians and Surgeons, New York, NY, USA

e-mail: [gr2106@cumc.columbia.edu](mailto:gr2106@cumc.columbia.edu)

---

**Abstract**

Diabetes mellitus is associated with significant increases in atherosclerotic cardiovascular disease (ASCVD). In type 1 diabetes mellitus (T1DM), increased ASCVD is linked to hyperglycemia, renal disease, and hypertension, with dyslipidemia contributing when present. In type 2 diabetes mellitus (T2DM), although the aforementioned complications of diabetes may each contribute to increased ASCVD, the dyslipidemia plays a more important role. Optimal glycemic control with diabetes medications can normalize plasma lipid levels in most individuals with T1DM. Insulin resistance is central to the pathophysiology of dyslipidemia in T2DM, with obesity and independently inherited detrimental lipid genes exacerbating the phenotype. Aggressive low density lipoprotein (LDL) lowering is key in individuals with T2DM because of their very high risk for ASCVD. High doses of potent statins are the first line of therapy followed by ezetimibe, which will be required to achieve LDL cholesterol levels well below 100 mg/dL. Therapy with lifestyle, and if needed, triglycerides (TG)-lowering agents such as fibrates and omega-3 fatty acid concentrates can be used to treat hypertriglyceridemia, with the understanding that these agents have not consistently reduced ASCVD events. When individuals with T2DM also have very high levels of LDL cholesterol, pro-protein convertase subtilisin/kexin type 9 (PCSK9) inhibitors should be considered.

---

**Keywords**

Diabetes mellitus · Dyslipidemia · Hypertriglyceridemia · Hypercholesterolemia · Very-low-density lipoproteins · Chylomicrons · Low-density lipoproteins · High-density lipoproteins · Apolipoprotein B · Apolipoprotein A-I

---

**Introduction**

Numerous prospective cohort studies have indicated that diabetes mellitus (DM) is associated with a 3–4-fold increase in risk for atherosclerotic cardiovascular disease (ASCVD) (Kannel et al. 1990; Haffner 1998; Haffner et al. 1998). Furthermore, patients with DM have a 50% greater in-hospital mortality and a 2-fold increased rate of death within 2 years of surviving a myocardial infarction. This increased risk is particularly evident in both younger age groups and women. Females with type 2 diabetes mellitus (T2DM) appear to lose a great deal of the protection from ASCVD that characterizes nondiabetic females. Of particular concern is the finding that the incidence and prevalence of T2DM have doubled between 1980 and 2012 with further rises noted in minorities such as Hispanics and African Americans (Geiss et al. 2014). In the USA in 2014, the number of newly diagnosed cases of T2DM was approximately 1.4 million. ASCVD is the major cause of morbidity and mortality in people with T2DM (Low Wang et al. 2016).

Although much of this increased risk is associated with the presence of well-characterized risk factors for ASCVD, a significant proportion remains unexplained. Patients with DM, particularly those with T2DM, have abnormalities of plasma lipids and lipoprotein concentrations that are less common in nondiabetics (Taskinen 1990; Dunn 1990; Ginsberg 1998). These lipid abnormalities include high triglycerides (TG), decreased high-density lipoprotein (HDL) cholesterol, and presence of small cholesteryl ester depleted low-density lipoprotein (LDL) particles and have been called the diabetic dyslipidemia. Patients with poorly controlled type 1 DM (T1DM) can also have a dyslipidemic pattern. In this chapter, we will focus on approaches to the diabetic patient with significant dyslipidemia. Normal lipid and lipoprotein physiology will be reviewed briefly as a base from which we will examine the approach to treating the dyslipidemia commonly associated with diabetes.

## Lipoprotein Composition

Lipoproteins are macromolecular complexes carrying various lipids and proteins in plasma (Ginsberg 1998). Several major classes of lipoproteins have been defined by their physical-chemical characteristics, particularly by their flotation characteristics during ultracentrifugation. However, lipoprotein particles actually form a continuum, varying in composition, size, density, and function (Table 1). The lipids are mainly free and esterified cholesterol, TG, and phospholipids. The hydrophobic TG and cholesteryl esters comprise the core of the lipoprotein, which is covered by a unilamellar surface containing mainly the amphipathic (both hydrophobic and hydrophilic) phospholipids and smaller amounts of free cholesterol and proteins. Hundreds to thousands of TG and cholesteryl ester molecules are carried in the core of different lipoproteins.

Apolipoproteins are the proteins on the surface of the lipoproteins. They not only help to solubilize the core lipids but also play critical roles in the regulation of plasma lipid and lipoprotein transport. The major apolipoproteins are described in

**Table 1** Physical-chemical characteristics of the major lipoprotein classes

Lipoprotein	Density	Molecular weight (MW)	Diameter	Lipid (%)		
				TG	Cholesterol (CHOL)	Plasma lipoprotein (PL)
Chylomicrons	0.95	$400 \times 10^6$	75–1200	80–95	2–7	3–9
VLDL	0.95–1.006	$10\text{--}80 \times 10^6$	30–80	55–80	5–15	10–20
IDL	1.006–1.019	$5\text{--}10 \times 10^6$	25–35	20–50	20–40	15–25
LDL	1.019–1.063	$2.3 \times 10^6$	18–25	5–15	40–50	20–25
HDL	1.063–1.21	$1.7\text{--}3.6 \times 10^6$	5–12	5–10	15–25	20–30

Density: gm/dL

MW: daltons

Diameter: nm

Lipids (%): percent composition of lipids; apolipoproteins make up the rest

**Table 2** Characteristics of the major apolipoproteins

Apolipoprotein	MW	Lipoproteins	Metabolic functions
apo A-I	28,016	HDL, chylomicrons	Structural component of HDL; LCAT activator
apo A-II	17,414	HDL, chylomicrons	Unknown
apo A-IV	46, 465	HDL, chylomicrons	Unknown; possibly facilitates transfer of apos between HDL and chylomicrons apo A5
apo B48	264,000	Chylomicrons	Necessary for assembly and secretion of chylomicrons from the small intestine
apo B100	514,000	VLDL, IDL, LDL	Necessary for the assembly and secretion of VLDL from the liver; structural protein of VLDL, IDL, and LDL; ligand for the LDL receptor
apo C-I	6630	Chylomicrons, VLDL, IDL, HDL	May inhibit hepatic uptake of chylomicrons and VLDL remnants
apo C-II	8900	Chylomicrons, VLDL, IDL, HDL	Activator of lipoprotein lipase
apo C-III	8800	Chylomicrons, VLDL, IDL, HDL	Inhibitor of lipoprotein lipase; inhibits hepatic uptake of chylomicron and VLDL remnants
apo E	34,145	Chylomicrons, VLDL, IDL, HDL	Ligand for binding of several lipoproteins to the LDL receptor, LRP, and proteoglycans
apo(a)	250,000–800,000	Lp(a)	Composed of LDL apoB linked covalently to apo(a); function unknown but is an independent predictor of coronary artery disease

Table 2. Apolipoprotein (apo) B100 is required for the secretion of hepatic-derived very-low-density lipoproteins (VLDL) and for circulating intermediate density lipoproteins (IDL) and LDL. Apo B48 is a truncated form of apo B100 that is required for secretion of chylomicrons from the small intestine. Apo A-I is the major structural protein in HDL. Apo A-I is also an important activator of the plasma enzyme, lecithin cholesteryl-acyl transferase (LCAT), which plays a key role in the movement of cholesterol from the periphery to the liver, often referred to as reverse cholesterol transport (RCT). Other apolipoproteins will be discussed in the context of their roles in lipoprotein metabolism. It is important to note that, in addition to well-characterized apolipoproteins, each of the lipoprotein classes carries additional proteins: HDL, for example, has a proteome of about 100 proteins. Little is known about the function of the proteome of each lipoprotein class, but this is an active area of research (Gordon et al. 2010).

## Transport of Dietary Lipids on apo B48-Containing Lipoproteins in Diabetes Mellitus

After ingestion of a meal, dietary fat (TG) and cholesterol are absorbed into the cells of the small intestine and are incorporated into the core of nascent chylomicrons. The newly formed chylomicrons are secreted into the lymphatic system and then enter the circulation via the thoracic duct into the superior vena cava. In the lymph and the blood, chylomicrons acquire apo C-II, apo C-III, and apo E. In the capillary beds of adipose tissue and muscle, chylomicrons interact with the enzyme lipoprotein lipase (LpL), which is activated by apo C-II, and the chylomicron core TG is hydrolyzed. The lipolytic products, free fatty acids (FAs), can be taken up by fat cells and reincorporated into TG or into muscle cells where they can be used for energy. Some fatty acids can bind to albumin and circulate in the blood with uptake by the liver, where they are used for energy or synthesized back to TG for secretion in VLDL. Apo C-III can inhibit lipolysis, and the balance of apo C-II and apo C-III determines, in part, the efficiency with which LpL hydrolyzes chylomicron TG. Three other proteins, apo A-V and the angiopoietin-like proteins (angptl3 and angptl4), are also important; apo A-V facilitates LpL-mediated lipolysis whereas angptl3 and angptl4 inhibit lipolysis. Recently, a protein called glycosylphosphoinositol HDL-binding protein-1 (GPIHBP1) was identified as critical component of LpL transport from adipose tissue or muscle to the luminal surface of capillary endothelial cells, where it anchors LpL. Absence of GPIHBP1 renders LpL inactive. Mutations in the gene for lipase maturation factor 1 are another rare cause of severe hypertriglyceridemia. Overall, in the past 15 years, the complexity of the processes removing TG from chylomicron (and VLDL) has become much better appreciated (GM et al. 2010; Olivecrona 2016).

Under normal conditions, apo B48-containing chylomicron remnants, which are the products of this lipolytic process, have lost about 80–85% of their TG and are relatively enriched in cholesteryl esters (both from the original dietary sources and from HDL-derived cholesteryl ester which has been transferred to the chylomicron by cholesteryl ester transfer protein [CETP]). The chylomicron remnants are also enriched in apo E, and this protein is important for the interaction of chylomicron remnants with several receptor and nonreceptor pathways on hepatocytes that rapidly remove them from the circulation. Uptake of chylomicron remnants involves binding to the LDL receptor, the LDL receptor related protein (LRP), hepatic lipase, and cell surface proteoglycans (Cooper 1997; Bishop et al. 2008).

Apo E is thought to play a critical role in the hepatic uptake of chylomicron remnants. The gene for apo E has three variants, E2, E3, and E4, which among other difference, bind to the LDL receptor with varying affinity. Apo E2 that is found in about 10% of the population and is defective in binding to the LDL receptor and individuals with both T2DM and either one or two apo E2 isoforms can have more severe dyslipidemia. Hepatic triglyceride lipase (HTGL), which both hydrolyzes chylomicron- and VLDL-remnant TG, as well as acting on HDL TG and phospholipids, may also play a role in remnant removal (Kobayashi et al. 2015). Deficiency of HTGL might, therefore, be associated with reduced remnant clearance. However,

several studies have indicated that HTGL is elevated in T2DM and may, because it can hydrolyze phospholipids on the surface of HDL leading to instability of the lipoprotein, be an important contributor to low HDL cholesterol levels in this disease.

Chylomicron and chylomicron-remnant metabolism can be altered significantly in diabetes. In untreated T1DM, LpL will be low, and postprandial TG levels will, in turn, be increased. Insulin therapy increases LpL, resulting in improved clearance of chylomicron TG from plasma. In well-controlled T1DM, LpL measured in post-heparin plasma (heparin releases LpL from the surface of endothelial cells where it is usually found), as well as adipose tissue LpL, can be normal or increased, and chylomicron TG clearance can be normal.

In T2DM, metabolism of dietary lipids is complicated by coexistent obesity and the hypertriglyceridemia associated with insulin resistance. Studies in diabetic animal models have demonstrated increased intestinal secretion of apo B48-containing lipoproteins, accompanied by increased expression, mass, and activity of intestinal microsomal TG transfer protein (MTP) (Adeli and Lewis 2008). Similar findings have been reported in humans with insulin resistance (IR) with or without T2DM and seem to be driven both by increased FA levels in plasma that can be taken up by enterocytes and the insulin-resistant state itself (Dash et al. 2015). Very recent studies indicate roles for the glucagon-like proteins in chylomicron assembly and secretion: GLP-1 inhibits and GLP-2 increases secretion of chylomicrons (Dash et al. 2015). Thus, there are more, possibly smaller, chylomicrons entering the circulation after consumption of a fatty meal by individuals with T2DM, raising the possibility of competition amongst chylomicrons (and VLDL) for LpL (Brunzell et al. 1973). The possibility of decreased efficiency of LpL-mediated lipolysis due to increased numbers of chylomicron T2DM is increased by modestly decreased LpL activity in IR states as well as increased apo C-III relative to apo C-II levels. Increased apo C-III secretion into plasma has been demonstrated in patients with diabetes and hypertriglyceridemia (Cohn et al. 2004; Nagashima et al. 2005), and this may also reduce hepatic uptake of chylomicron remnants. There have also been reports of alterations in hepatic heparin sulfate proteoglycans in mouse models of diabetes, further affecting negatively remnant removal by the liver.

---

## **Transport of Endogenous Lipids on apo B100-Containing Lipoproteins in Diabetes Mellitus**

### **VLDL**

Whereas the role of chylomicrons is to transport dietary nutrients from the small intestine to adipose tissue, skeletal muscle, and the liver, the role of VLDL appears to be the transport of excess energy from the liver to adipose tissue and skeletal muscle. This extra energy is in the form of TG that can derive from amino acids via gluconeogenesis and hepatic de novo lipogenesis (DNL), glucose via DNL, and



FAs taken up from the circulation. Three major sources of hepatic FAs can be involved in VLDL assembly; the first is increased hepatic FA flux to the liver from adipose tissue in IR with or without DM due to reduced anti-lipolytic effects of insulin on adipocytes. The importance of FA uptake by the liver for VLDL secretion has been demonstrated in mice infused with oleic acid bound to albumin (Zhang et al. 2004) and in humans receiving lipid emulsions and heparin (Lewis et al. 1995). Secondly uptake of TG-containing chylomicrons and VLDL remnants can also stimulate assembly and secretion of VLDL (Cooper 1997). Finally, in animal models, increased hepatic DNL stimulates VLDL TG secretion but, unlike increased uptake of FA or remnants from the circulation, which stimulate secretion of both apo B100 and TG, increases in DNL are associated with secretion of the same number of larger, more TG-rich particles (Horton et al. 1999; Grefhorst et al. 2002). These findings are consistent with increased rates of DNL in people with T2DM (Ma et al. 2015) and increased secretion of the more buoyant and TG-rich VLDL1 subclass in the same group (Adiels et al. 2005). In fact, the major factors correlating with secretion of VLDL1 are hepatic fat and the level of glycemia. Importantly, however, IR/T2DM is also associated with assembly and secretion of VLDL particles as measured by secretion rates of apo B100.

Throughout the day, during both fasting and postprandial states, the liver assembles and secretes VLDL. VLDL is assembled in the endoplasmic reticulum of hepatocytes. As described above, VLDL TG derives from the combination of glycerol with circulating FAs derived from adipose tissue and taken up by the liver, FAs derived from chylomicron and VLDL remnants uptake by the liver, and FAs produced from glucose by hepatic de novo lipogenesis (DNL). Of these three, circulating FAs are by far the major source of TG-FAs in the liver (Donnelly et al. 2005). VLDL cholesterol is either synthesized in the liver from acetate or delivered to the liver by lipoproteins, mainly chylomicron remnants and LDL. The driving force for VLDL secretion is mainly the maintenance of normal hepatic TG levels, although hepatic cholesterol metabolism also can affect VLDL production. Apo B100 and phospholipids form the surface of VLDL; there is one apo B100 on each VLDL particle and, therefore, the rate of secretion of apo B100 determines the number of VLDL particles entering the circulation. Since VLDL is the precursor of LDL, high rates of VLDL apo B100 secretion usually result in increased levels of LDL. Although some apo C-I, apo C-II, apo C-III, and apo E are present on the nascent VLDL particles as they are secreted from the hepatocyte, the majority of these molecules are probably added to VLDL after their entry into plasma. Importantly, a significant proportion of newly synthesized apo B100 may be degraded before secretion, and this degradation is inhibited when hepatic lipids are abundant (Ginsberg and Fisher 2009).

Once in the plasma, hydrolysis of VLDL TG by LpL is key for the delivery of VLDL TG-FA to adipose tissue and muscle, and this process can be modulated by all the factors that affected chylomicron lipolysis: apo C-II, apo C-III, apo A-V, the angptl proteins, and GPIHBP1. The result is generation of smaller, denser, cholesterol ester-enriched VLDL called VLDL remnants. IDL are very closely related to VLDL remnants but for the purposes of this chapter will be considered to be

products of further lipolysis of VLDL remnants. VLDL remnants are similar to chylomicron remnants except that they carry apo B100 rather than apo B48. Additionally, unlike chylomicron remnants, not all VLDL remnants are removed by the liver but can be converted to IDL and LDL. IDL particles can also be taken up by the liver or undergo further catabolism to become LDL. Some LpL activity appears necessary for normal functioning of the metabolic cascade from VLDL to IDL to LDL. It also appears that apo E, HTGL, apo C-III, LDL receptors, and hepatic cell surface proteoglycans all play important roles in this process, with HTGL having roles in both uptake of VLDL remnants and IDL by the liver and further lipolysis of IDL to produce LDL. Apo B100 is essentially the sole protein on the surface of LDL, and the lifetime of LDL in plasma appears to be mainly determined by the availability of LDL receptors. Overall, about 80% of LDL catabolism from plasma occurs via the LDL receptor pathway, while the remaining tissue uptake is by nonreceptor or alternative-receptor pathways. One of these alternative pathways may recognize glycosylated and/or oxidatively modified lipoproteins, which can be present in increased amounts in the blood of patients with DM (Ginsberg 1991).

Diabetic patients commonly have elevated plasma levels of VLDL TG, in the range of 150–250 mg/dL. In T1DM, TG levels correlate closely with glycemic control, and marked hyperlipemia can be found during episodes of ketoacidosis. The basis for increased VLDL levels in poorly controlled but nonketotic T1DM subjects is usually overproduction of these lipoproteins (Dunn 1990). Reduced clearance plays a more significant role in severe cases of high TG in uncontrolled T1DM. This results from a reduction of LpL, which returns to normal with adequate insulinization. Plasma TG can actually be “low-normal” with intensive insulin treatment in T1DM, and lower than average production rates of VLDL have been observed in such instances. Several qualitative abnormalities in VLDL composition may persist, which include enrichment in free and esterified cholesterol as well as an increase in the ratio of free cholesterol to lecithin. The latter may be an indication of increased risk for ASCVD.

Overproduction of VLDL, with increased secretion of both triglyceride and apo B100, seems to be the central etiology of increased plasma VLDL levels in patients with T2DM (Adiels et al. 2008). As described above, there are three sources of fatty acids that can stimulate VLDL assembly and secretion, and they can all be increased in T2DM: increased FA flux to the liver resulting from adipose tissue IR, uptake of VLDL and chylomicron remnants that are more TG-enriched than normal because of somewhat reduced LpL activity, and increased DNL. As noted above, the first two increase secretion of both VLDL TG and apo B100 whereas the third only increases VLDL TG secretion. Thus, greater rates of DNL in people with T2DM are associated with larger, more TG-enriched VLDL. Of these three, circulating FAs are by far the major source of TG-FAs in the liver (Donnelly et al. 2005). It is important to note that hepatic IR pertains to loss of the inhibitory effects of insulin on hepatic gluconeogenesis, whereas insulin seems to maintain its lipogenic effects. Additionally, increased assembly and secretion of VLDL occur despite the demonstration that acute hyperinsulinemia targets apo B100 for degradation in cultured liver cells. The

loss of that action of insulin results from the development of IR in the pathway of apo B100 degradation during chronic hyperinsulinemia (Moon et al. 2012).

Because obesity, IR, and independently inherited familial forms of hyperlipidemia are common in T2DM, study of the pathophysiology is difficult. The interaction of these overlapping traits also makes therapy less effective. In contrast to T1DM, where intensive insulin therapy normalizes (or even “super-normalizes”) VLDL levels and metabolism, therapy of T2DM with either insulin or oral agents only partly corrects VLDL abnormalities in the majority of patients. Therapies for the diabetic dyslipidemia will be discussed later in this chapter.

## LDL

If glycemic control is good, LDL cholesterol levels and LDL metabolism are usually normal in patients with T1DM. In fact, with intensive insulin treatment, LDL production falls concomitant with reduced VLDL production (Dunn 1990). The LDL receptor is regulated to some extent by insulin, and severe insulin deficiency may lead to reduced catabolism of LDL. Patients with T1DM may have increased ratios of free cholesterol:lecithin even when glycemic control is adequate. Glycosylation of LDL does appear to occur in poorly controlled patients with DM, and reduced catabolism of LDL via the LDL receptor pathway has been observed in some, but not all, *in vitro* studies using diabetic LDL and cultured fibroblasts.

In T2DM, regulation of plasma levels of LDL, like that of its precursor VLDL, is complex. In the presence of hypertriglyceridemia, dense, triglyceride-enriched and cholesteryl ester depleted LDL is present. Thus individuals with T2DM and mild to moderate hypertriglyceridemia may have the pattern B profile of LDL described by Austin and Krauss (Austin et al. 1990). Patients with T2DM can be shown to have overproduction of LDL apo B100 even with mild degrees of hyperglycemia, particularly if there is concomitant elevation of VLDL. This situation is made more complex by the observation that there is both reduced VLDL conversion to LDL and direct LDL entry into plasma in T2DM (Kissebah et al. 1982).

Fractional removal of LDL, mainly via LDL receptor pathways, can be increased, normal, or reduced in T2DM. Increased LDL fractional catabolism is often seen in nondiabetics with significant hypertriglyceridemia, and while the basis for this is uncertain, elevated plasma triglyceride levels can probably also increase LDL catabolism in patients with T2DM. As insulin seems to be required for normal LDL receptor function, reduced LDL fractional removal from plasma has therefore been observed in poorly controlled T2DM. This could also be a consequence of glycosylation of LDL. These multiple potential effects on LDL metabolism make it difficult to predict what level of LDL will be present in any individual with T2DM. Overall, LDL elevations are uncommon in men with T2DM, although women with T2DM tend to have higher levels of LDL than women without diabetes. Of course, any one individual could have a high LDL-C based on unrelated genetic influences, and with increasing obesity, T2DM is becoming more common in people with familial hypercholesterolemia.

Some investigators have suggested that glycosylated LDL can be taken up by macrophage scavenger receptors and contribute to foam cell formation. Other studies indicate that LDL from patients with diabetes, particularly small, dense LDL, may be more susceptible to oxidative modification and catabolism via macrophage scavenger receptors.

In summary, T1DM may be associated with elevations of VLDL triglyceride and LDL cholesterol if diabetic control is very poor or if the patient is actually ketotic. In contrast, T2DM is usually almost always associated with lipid abnormalities, most common of which are high TG, reduced HDL-C levels, and the presence of smaller, cholesteryl ester depleted LDL.

---

## Transport of apo A-Containing Lipoproteins in Diabetes Mellitus

### HDL

HDL may be the most complex of all the lipoprotein class. Subclasses of HDL, varying in size, density, lipid composition, and apolipoprotein components, have been isolated by a variety of physical-chemical techniques. Although we refer to HDL as the “apo A”-containing lipoproteins, as noted earlier there are approximately 100 proteins associated with HDL (Gordon et al. 2010).

Nascent HDL is secreted from the liver and the small intestine as phospholipid discs mainly containing apo A-I; they are called pre-beta HDL. The liver is the source of about 70% of these nascent HDLs (Timmins et al. 2005; Brunham et al. 2006). These disc-like HDLs, particularly those with apo A-I, appear to be the best acceptors of membrane free cholesterol and may be the initial HDL particles involved in RCT. The initial step in this process begins with the ATP-binding cassette transporter A1 (ABCA1) transferring intracellular and plasma membrane free (unesterified) cholesterol to pre-beta HDL. The next step, which begins the process of generating mature HDL, involves the conversion of free cholesterol to cholesterol esters (CE) by LCAT, which is activated by apo A-I. CEs move from the surface to the core of the maturing HDL particle, allowing addition of more free cholesterol to the surface, followed by more CE generation. As HDL particles mature, additional free cholesterol can also be added via ATP-binding cassette transporter G1 (ABCG1) and scavenger receptor B1 (SR-B1), giving rise to mature, CE-rich HDL. Mature HDL particles can deliver both free and esterified cholesterol to the liver via interaction with SR-B1 (Trigatti et al. 2000; Shen et al. 2017). It has yet to be proven, however, that RCT is critical for “clearing” cholesterol from peripheral tissues, including foam cells in arterial plaques, to the liver (Tall and Rader 2018).

In humans, the CETP-mediated transfer of cholesteryl ester from HDL to triglyceride-rich lipoproteins (chylomicrons and VLDL in the fed and fasted states, respectively) appears to be an alternative pathway for RCT as the cholesteryl esters can then be taken up by the liver; chylomicron remnants, VLDL remnants or IDL, and finally LDL are all active participants in this pathway. However, if hepatic LDL receptors are downregulated, the CE enriched apoB lipoproteins will circulate for

extended periods of time and can deliver their CE back to the vessels from which they originally came.

In T2DM, multiple factors acting in concert result in lower levels of HDL-C and apo A-I. CETP-mediated exchange of TG for CE in both the fasting and postprandial states clearly plays an important role in altering HDL levels in T2DM (Riemens et al. 1998). TG enrichment of HDL is followed by lipolysis of TG, mainly by HTGL, leading to generation of smaller HDL particles from which apo A-I can dissociate (Horowitz et al. 1993). The free apo A-I can be filtered through the glomerulus and then taken up and degraded by renal tubular cells (Horowitz et al. 1993); this increased clearance of apo A-I from plasma, confirmed by HDL turnover studies demonstrating increased apo A-I fractional removal rates, is the hallmark of low levels of the protein and HDL-C in states of IR and low HDL (Horowitz et al. 1993; Brinton et al. 1994). Thus, CETP-mediated mechanisms result in both less CE in HDL and fewer HDL particles. However, IR itself lowers HDL levels by pathways that are not fully understood. Recent studies demonstrated that when hepatic insulin signaling is reduced, apo A-I gene expression and protein synthesis are decreased by a mechanism involving type 1 deiodinase in the liver (Liu et al. 2016). Increased hydrolysis of HDL phospholipids by HL activity, which is increased in IR/T2DM, results in disruption of particles with loss of CE and apo A-I (Deeb et al. 2003). The decrease in HDL particles available for participation in RCT may be important to the atherogenicity of the dyslipidemia associated with T2DM.

In T1DM, HDL cholesterol levels are often normal, and studies of the relationship between HDL cholesterol levels and degree of glycemic control in these patients have been inconsistent. HDL levels may actually be increased in individuals receiving intensive insulin therapy, and this may be linked to increased LpL activity and/or reduced HTGL activity. Lipoprotein turnover studies indicate that there are no differences in apo A-I metabolism between patients with T1DM and nondiabetics when they are matched for a wide range of HDL cholesterol concentrations.

Reduced plasma HDL cholesterol levels do not seem to be related to control or mode of treatment in patients with T2DM. Once again, however, understanding the metabolism of HDL in T2DM is complicated by the common presence of obesity and insulin resistance-associated dyslipidemias in this group. A consistent finding is the inverse relationship between plasma insulin (or C-peptide) concentrations, which are measures of insulin resistance, and HDL-C levels.

---

## Treatment of Diabetic Dyslipidemia

### Nonpharmacologic Therapies

The centerpiece of therapy for the treatment of diabetes is always diet, irrespective of the absence or presence of dyslipidemia (American Diabetes Association 2018). However, the presence of dyslipidemia increases the rationale for intensive diet

intervention. It is important to remember that improvements in plasma triglyceride and total cholesterol levels during dietary intervention can be observed even in the absence of weight loss. Thus, reductions in dietary saturated fat intake, along with reduced cholesterol consumption, can lower plasma TG and LDL cholesterol levels even if caloric intake is unchanged. Which nutrients to use as replacement for saturated fats, i.e., carbohydrates or mono- and polyunsaturated fats, has been one of the longest ongoing controversies in the field of nutrition. However, when the patient also has diabetes, the issue becomes less contentious because of the need to control carbohydrate intake. We will not discuss this further, other than to say that simultaneous control of both plasma glucose and lipids (particularly triglycerides) is possible with judicious use of high fiber carbohydrates balanced with moderate increases in mono- and polyunsaturated fats as replacements for saturated fats.

Of course, achievement of optimum weight, which for many people with T2DM and dyslipidemia requires a BMI of 27 or less, is probably as important, or more important, than the exact balance of nutrients. Unfortunately, the optimal weight loss diet in anyone, and in particular in people with diabetes and dyslipidemia, is even more controversial than the optimal isocaloric nutrient mix (American Diabetes Association 2018). One exception would be patients with severe hypertriglyceridemia ( $>1000$  mg/dL), who are at risk or have already had episodes of pancreatitis. These patients require very low fat diets ( $<15\%$  calories) with high fiber carbohydrates as replacement calories. In the most extreme cases, or when glucose control is difficult to achieve because of the increased carbohydrate intake, medium chain triglycerides, which are not carried in chylomicrons, can be used to allow for less carbohydrate intake without affecting plasma triglyceride levels. Many of these individuals would benefit from weight loss, so reduction in dietary fat intake without nutrient replacement is a good option.

The omega-3 fatty acids are unique polyunsaturated fatty acids that continue to arouse considerable interest (American Heart Association 2017). These fatty acids, found mostly in fatty fish, are comprised mainly of eicosapentaenoic acid and docosahexaenoic acid. Alpha-linolenic acid, present in vegetables such as linseed, is also an omega-3 FA. When consumed in large quantities (3–4 gm/day), the omega-3 FAs can cause a very significant decrease in plasma VLDL concentrations in subjects with severe ( $>1000$  mg/dL) hypertriglyceridemia. In milder forms of hypertriglyceridemia, reductions in VLDL are often associated with increases in plasma LDL and apoB levels. These responses to increased intake of omega-3 FA, whether as fish or supplements, have been observed in both nondiabetics and diabetics. Several cohort studies and intervention trials suggest that diets high in omega-3 fatty acids are associated with reduced rates of ASCVD in high-risk populations (American Heart Association 2017). Although ingestion of increased quantities of fish should be recommended, the evidence for use of large doses of omega-3 FA supplements is, at best, minimal and not recommended for the prevention of most types of cardiovascular disease (American Heart Association 2017). This recommendation may change in the near future if two large, ongoing ASCVD outcome trials with high doses of omega-3 fatty acid concentrates are positive.

## Lipid Lowering Therapies

### Current Treatment Guidelines

In the past 30 years, a series of guidelines, both in the USA and other countries, have progressively addressed accumulating data demonstrating the efficacy of lowering LDL cholesterol levels to prevent ASCVD. Most guidelines have recognized the significantly increased risk of ASCVD in people with diabetes mellitus, although not necessarily considering them to have coronary heart disease (CHD) equivalence (Low Wang et al. 2016). In the 2013 American College of Cardiology/American Heart Association (ACC/AHA) guidelines on the Treatment of Blood Cholesterol to Reduce Atherosclerotic Cardiovascular Risk in Adults, which markedly altered approaches to lowering LDL-C in people at risk for cardiovascular disease (CVD) in the USA (Stone et al. 2014), diabetes was considered to be a high risk category and treatment with high doses of potent statins recommended for secondary prevention patients and moderate to high dose treatment for those who have not had an event yet, depending on overall risk. The recently released 2015 ACC/AHA report (Drozda et al. 2015) suggested that individuals with diabetes receive moderate-intensity statin therapy for adults 40–75 years, with high-intensity statin therapy to be considered for such individuals with a  $\geq 7.5\%$  estimated 10-year ASCVD risk or a prior CVD event. In adults with diabetes, who are  $<40$  years of age or  $>75$  years of age, or who have a LDL  $<70$  mg/dL, it was recommended that health providers evaluate the potential for ASCVD benefits and for adverse effects and drug–drug interactions and to consider patient preferences when deciding to initiate, continue, or intensify statin therapy. Similar recommendations have been issued by the European Atherosclerosis Society (EAS), European Society of Cardiology (ESC) (ESC/EAS 2016), and the European Association for the Study of Diabetes (EASD) (Ryden et al. 2007). Fortunately for our patients, we have outstanding pharmacologic therapies for those patients requiring more than nutrition and exercise prescriptions. As noted above, this applies to almost everyone with diabetes mellitus.

### Statins

Statin therapy is considered first-line treatment for hyperlipidemia in all patients, including those with diabetes (Stone et al. 2014). In a meta-analysis of 14 RCTs which included 18,686 patients with T2DM, statin monotherapy resulted in a 9% reduction in all-cause mortality and a 21% reduction in the incidence of major cardiovascular incidents per mmol/L of LDL lowered (Kearney et al. 2008). There are several agents available for clinical use: lovastatin, fluvastatin, pravastatin, simvastatin, atorvastatin, rosuvastatin, and pitavastatin. These agents lower LDL-C by 18–55% depending on dose and the statin used, increase HDL-C by 5–10%, and reduce TG levels by 7–30% (Ginsberg 2006).

Statins lower LDL-C by inhibiting cholesterol biosynthesis, which by reducing hepatic cholesterol concentrations, leads to upregulation of hepatic LDL receptors

and increased LDL particle clearance. In insulin-resistant individuals with dyslipidemia, statins can also reduce the hepatic assembly and secretion of apo B-containing lipoproteins (Ginsberg 2006).

**Ezetimibe:** This drug reduces plasma LDL cholesterol by inhibiting intestinal absorption of both dietary cholesterol and cholesterol entering the intestinal track from the biliary tree. The loss of cholesterol in feces leads to an upregulation in the liver of both cholesterol synthesis and the synthesis of LDL receptors. The latter effect predominates, resulting in greater LDL receptor-mediated uptake of circulating LDL particles and, therefore, lowering of plasma LDL cholesterol levels. After several studies of the effects of ezetimibe on ASCVD risk that produced mixed outcomes, the Improved Reduction of Outcomes: Vytorin Efficacy International Trial (IMPROVE-IT) demonstrated reduced ASCVD events with lowering of LDL cholesterol from 67 to 54 mg/dL (Cannon et al. 2015). Although the relative benefit was small (about 7%), it was concordant with what would be expected based on the meta-analysis of all statin trials, where a lowering of LDL cholesterol of about 39 mg/dL results in about a 23% reduction event. This trial was not only crucial because it supported the use of a nonstatin drug in combination with statin treatment but because it supported the LDL hypothesis, which is that lowering LDL cholesterol by any means will reduce rates of ASCVD events (MG et al. 2016). Importantly, and consistent with many of the statin-monotherapy trials, participants with diabetes mellitus had the highest event rates and the best therapeutic response to LDL lowering.

**PCSK9 Inhibitors:** Serum proprotein convertase/subtilisin kexin 9 (PCSK9) binds to low-density lipoprotein receptors and targets them to the lysosome, along with LDL, instead of allowing them to recycle efficiently. This results in fewer LDL receptors on the surface of cells, particularly the liver, increasing serum LDL-C (Seidah 2011). In response to a rapid series of preclinical studies and population genetics (Cohen et al. 2006), several companies developed monoclonal antibodies that bind PCSK9 in the circulation, rendering them unable to bind to the LDL receptor. Two fully human monoclonal antibodies to PCSK9, evolocumab and alirocumab, have shown the ability to reduce LDL levels between 50–70% in short-term studies and were approved by the Food and Drug Administration (FDA) and the European Medicines Agency (EMA). Secondary analyses of the OSLER and ODYSSEY LONG TERM studies of the efficacy of evolocumab and alirocumab, respectively, published in 2015, demonstrated evidence of improving patient outcomes by reducing the rate of major adverse cardiovascular events (MACE) compared to standard statin therapy (Sabatine et al. 2015; Robinson et al. 2015). They were followed by the publication by the full Fourier outcome trial (Sabatine et al. 2017a) and a secondary analysis of Fourier subjects with and without diabetes mellitus (Sabatine et al. 2017b) that both showed significant reductions in MACE with evolocumab therapy in patients already receiving statins. The Odyssey Outcomes trial with alirocumab will be reported in the near future (Schwartz et al. 2014). Development of a siRNA is ongoing and may allow fewer injections with similar efficacy (Ray et al. 2017). PCSK9 inhibitors may be a major advance in the treatment of individuals with T2DM who have very high plasma LDL cholesterol levels in addition to the typical diabetic dyslipidemia.



**Fibrates:** Although fibrates have been available for more than 40 years as effective agents to lower triglyceride and raise HDL cholesterol levels, their efficacy as cardioprotective drugs remains in doubt. Several early studies of fibrate monotherapy to reduce CVD events, including the Helsinki Heart Study, the VA-HIT Study, and the Bezafibrate Infarction Prevention Trial, gave variable results (Frick et al. 1987; Rubins et al. 1999; Bezafibrate Infarction Prevention (BIP) Study 2000). Two fibrate trials that focused on patients with T2DM, FIELD (Keech et al. 2005) and ACCORD (Ginsberg et al. 2010), failed to meet their primary outcomes, although a prespecified subgroup analysis of ACCORD patients defined by TG levels in the upper tertile ( $>204$  mg/dL) and HDL-C levels in the lower tertile ( $<34$  mg/dL) had 29% fewer events than those without dyslipidemia. This dyslipidemic group comprised 17% of the total participants. The latter results remained constant in a 6 year observational follow-up of the trial (Elam et al. 2017). Importantly, post-hoc analyses of the Helsinki Heart Study (Frick et al. 1987), the Bezafibrate Infarction Prevention Trial (Bezafibrate Infarction Prevention (BIP) Study 2000), and FIELD (Scott et al. 2009) both showed marked benefits in groups with baseline TG levels greater than 200 mg/dL with or without low HDL-C levels. A study with a new fibrate, pemafibrate, is just starting and will enroll 10,000 participants, all with TG levels  $>200$  mg/dL and HDL-C  $<40$  mg/dL. It will take several years for the trial to be completed.

**Niacin:** Niacin was a mainstay of the treatment of patients with familial hypercholesterolemia in the pre-statin era. In the 1970s, the Coronary Drug Project Niacin arm showed a significant reduction in CVD events in men who had survived prior events. In the ensuing years, niacin was used for treatment of hypertriglyceridemia and low HDL-C. Niacin has many side effects that are annoying but harmless (flushing, itching), but it can also be hepatotoxic and can worsen preexisting diabetes or convert individuals with prediabetes to full diabetes. Because of the latter problems, niacin was used very sparsely and with care in individuals with T2DM, despite its excellent effects on all the classes of lipoproteins. Two recent studies, Atherothrombosis Intervention in Metabolic Syndrome with Low HDL/High Triglycerides and Impact on Global Health Outcomes (AIM-HIGH) (Boden et al. 2011) and the Heart Protection Study 2—Treatment of HDL to Reduce the Incidence of Vascular Events (HPS2-THRIVE) (Landray et al. 2014), in which niacin was added to statin therapy, failed to show benefit over statin alone and confirmed the diabetogenic effects of niacin. As a result, use of niacin has fallen to very low levels overall and is rarely used in people with prediabetes or diabetes.

**Bile Acid Binding Resins:** Interrupting the enterohepatic recirculation of bile acids causes the liver to increase both cholesterol synthesis and LDL receptors to bring more cholesterol into the liver. The result is a lowering of circulating LDL cholesterol ranging from 10% to 25% depending on the dose taken. Early versions of the binding resins, cholestyramine and colestipol, were difficult to take and had significant gastrointestinal side effects. However, both were demonstrated to reduce ASCVD in large randomized trials (National Cholesterol Education Program 2002). A drawback to their use was an increase in hepatic VLDL triglyceride production and plasma triglyceride levels. A new agent in this class is colesevelam, which has greater tolerability and fewer drug interactions than the other resins. GI side effects seem to be significantly

reduced compared to the older bile acid sequestrants. All of the bile acid binding resins work very well with statins and with ezetimibe. Importantly, colesevelam reduces blood glucose concentrations with HbA1c reductions of about 0.5% achieved in people with diabetes (Hansen et al. 2017). This added benefit makes the bile acid sequestrants a good choice as a second drug in individuals with very high baseline LDL cholesterol levels who do not reach LDL goals on statin monotherapy.

---

## Summary

Diabetes mellitus is associated with significant increases in all types of ASCVD. In T1DM, increased ASCVD is linked to hyperglycemia, renal disease, and hypertension, with dyslipidemia contributing when it is present. In T2DM, although the aforementioned complications of diabetes may each contribute to increased ASCVD, the dyslipidemia, which is almost universally present, plays a more important role. The dyslipidemia of T2DM affects both the intestinal and the hepatic lipoprotein pathways, with increased levels of apo B48 and apo B100 TG-rich lipoproteins (VLDL and chylomicrons and their remnants). LDL levels can vary and are linked both to abnormalities in VLDL metabolism and to common genes for hypercholesterolemia that can be independently inherited in individuals with either T1DM or T2DM. Treatments of lipid abnormalities in patients with T1DM are directed to glucose control: optimal therapy with diabetes medications can normalize plasma lipid levels in most instances. In T2DM, the dyslipidemia is most closely linked to the underlying insulin resistance in this patient population, with obesity and independently inherited detrimental lipid genes exacerbating the insulin-resistant dyslipidemia. Treatment options are both numerous and effective, with statin therapy of critical importance to lower risk for ASCVD. Because of the very high risk for ASCVD events in people with T2DM, aggressive LDL lowering is key, with high doses of potent statins the first line of therapy followed by ezetimibe, which will be required to achieve LDL cholesterol levels well below 100 mg/dL. Therapy with lifestyle, and if needed TG-lowering agents such as fibrates and omega-3 fatty acid concentrates, can be used to treat hypertriglyceridemia, with the understanding that these agents have not consistently reduced ASCVD events. For individuals with T2DM unfortunate enough to also have very high levels of LDL cholesterol, either on a polygenic basis or because they also have familial hypercholesterolemia, PCSK9 inhibitors should be considered.

---

## References

- Adeli K, Lewis GF. Intestinal lipoprotein overproduction in insulin-resistant states. *Curr Opin Lipidol.* 2008;19:221–8.
- Adiels M, Boren J, Caslake MJ, Stewart P, Soro A, Westerbacka J, Wennberg B, Olofsson SO, Packard C, Taskinen MR. Overproduction of VLDL1 driven by hyperglycemia is a dominant feature of diabetic dyslipidemia. *Arterioscler Thromb Vasc Biol.* 2005;25:1697–703.

- Adiels M, Olofsson SO, Taskinen MR, Boren J. Overproduction of very low-density lipoproteins is the hallmark of the dyslipidemia in the metabolic syndromes. *Arterioscler Thromb Vasc Biol*. 2008;28:1225–36.
- American Diabetes Association. Cardiovascular disease and risk management: standards of medical care in diabetes. *Diabetes Care*. 2018;41(Suppl 1):S86–S104.
- American Heart Association. Omega-3 polyunsaturated fatty acid (fish oil) supplementation and the prevention of clinical cardiovascular disease: a science advisory from the American Heart Association. *Circulation*. 2017;135(15):e867–84.
- Austin MA, King MC, Vranizan KM, Krauss RM. Atherogenic lipoprotein phenotype. A proposed genetic marker for coronary heart disease risk. *Circulation*. 1990;82(2):495–506.
- Bezafibrate Infarction Prevention (BIP) Study. Secondary prevention by raising HDL cholesterol and reducing triglycerides in patients with coronary artery disease. Bezafibrate Infarction Prevention (BIP) study. *Circulation*. 2000;102:21–7.
- Bishop JR, Stanford KI, Esko JD. Heparan sulfate proteoglycans and triglyceride-rich lipoprotein metabolism. *Curr Opin Lipidol*. 2008;19:307–13.
- Boden WE, Probstfield JL, Anderson T, Chaitman BR, svignes-Nickens P, Koprowicz K, McBride R, Teo K, Weintraub W. Niacin in patients with low HDL cholesterol levels receiving intensive statin therapy. *N Engl J Med*. 2011;365:2255–67.
- Brinton EA, Eiseberg S, Breslow JL. Human HDL cholesterol levels are determined by apoA-I fractional catabolic rate, which correlates inversely with estimate of HDL particle size. *Arterioscler Thromb*. 1994;14:707–20.
- Brunham LR, Kruit JK, Iqbal J, Fieviet C, Timmins JM, Pape TD, Coburn BA, Bissada N, Staels B, Groen AK, Hussain MM, Parks JS, Kuipers F, Hayden MR. Intestinal ABCA1 directly contributes to HDL biogenesis in vivo. *J Clin Invest*. 2006;116:1052–62.
- Brunzell JD, Hazzard WR, Porte D Jr, Bierman EL. Evidence for a common, saturable, triglyceride removal mechanism for chylomicrons and very low density lipoproteins in man. *J Clin Invest*. 1973;52:1578–85.
- Cannon CP, Blazing MA, Giugliano RP, McCagg A, White JA, Theroux P, Darius H, Lewis BS, Ophuis TO, Jukema JW, et al. Ezetimibe added to statin therapy after acute coronary syndromes. *N Engl J Med*. 2015;372:2387–97.
- Cohen JC, Boerwinkle E, Mosley TH Jr, Hobbs HH. Sequence variations in PCSK9, low LDL, and protection against coronary heart disease. *N Engl J Med*. 2006;354(12):1264–72.
- Cohn JS, Patterson BW, Uffelman KD, Davignon J, Steiner G. Rate of production of plasma and very-low-density lipoprotein (VLDL) apolipoprotein C-III is strongly related to the concentration and level of production of VLDL triglyceride in male subjects with different body weights and levels of insulin sensitivity. *J Clin Endocrinol Metab*. 2004;89(8):3949–55.
- Cooper AD. Hepatic uptake of chylomicron remnants. *J Lipid Res*. 1997;38:2173–92. Review
- Dash S, Xiao C, Morgantini C, Lewis GF. New insights into the regulation of chylomicron production. *Annu Rev Nutr*. 2015;35:265–94.
- Deeb SS, Zambon A, Carr MC. Hepatic lipase and dyslipidemia: interactions among genetic variants, obesity, gender, and diet. *J Lipid Res*. 2003;44:1279–86.
- Donnelly KL, Smith CI, Schwarzenberg SJ, Jessurun J, Boldt MD, Parks EJ. Sources of fatty acids stored in liver and secreted via lipoproteins in patients with nonalcoholic fatty liver disease. *J Clin Invest*. 2005;115:1343–51.
- Drozda JP Jr, Ferguson TB Jr, Jneid H, Krumholz HM, Nallamothu BK, Olin JW, Ting HH. ACC/AHA focused update of secondary prevention lipid performance measures: a report of the American College of Cardiology/American Heart Association Task Force on Performance Measures. *J Am Coll Cardiol*. 2015;67:558–87.
- Dunn FL. Hyperlipidemia in diabetes mellitus. *Diabetes Metab Rev*. 1990;6:47–61.
- Elam MB, Ginsberg HN, Lovato LC, Corson M, Largay J, Leiter LA, Lopez C, O'Connor PJ, Sweeney ME, Weiss D, Friedewald WT, Buse JB, Gerstein HC, Probstfield J, Grimm R, Ismail-Beigi F, Goff DC Jr, Fleg JL, Rosenberg Y, Byington RP, ACCORDION Study Investigators. Association of fenofibrate therapy with long-term cardiovascular risk in statin-treated patients with type 2 diabetes. *JAMA Cardiol*. 2017;2:370–80.

- ESC/EAS. Guidelines for the management of dyslipidaemias: the Task Force for the management of dyslipidaemias of the European Society of Cardiology (ESC) and European Atherosclerosis Society (EAS) developed with the special contribution of the European Association for Cardiovascular Prevention & Rehabilitation (EACPR). *Eur Heart J*. 2016;39:2999–30581.
- Frick MH, Elo MO, Haapa K, et al. Helsinki Heart Study: primary-prevention trial with gemfibrozil in middle-aged men with dyslipidemia. Safety of treatment, changes in risk factors, and incidence of coronary heart disease. *N Engl J Med*. 1987;317:1237–45.
- Geiss LS, Wang J, Cheng YJ, Thompson TJ, Barker L, Li Y, Albright AL, Gregg EW. Prevalence and incidence trends for diagnosed diabetes among adults aged 20 to 79 years, United States, 1980–2012. *JAMA*. 2014;312:1218–26.
- Ginsberg HN. Lipoprotein physiology in nondiabetic and diabetic states. Relationship to atherogenesis. *Diabetes Care*. 1991;14:839–55. Review
- Ginsberg HN. Lipoprotein Physiology. In: Hoeg J, editor. *Endocrinology and metabolism clinics of North America*. Philadelphia: W.B. Saunders; 1998.
- Ginsberg HN. Efficacy and mechanism of action of statins in the treatment of diabetic dyslipidemia. *J Clin Endocrinol Metab*. 2006;91:383–92.
- Ginsberg HN, Fisher EA. The ever-expanding role of degradation in the regulation of apolipoprotein B metabolism. *J Lipid Res*. 2009;50:S162–6.
- Ginsberg HN, Elam MB, Lovato LC, Crouse JR III, Leiter LA, Linz P, Friedewald WT, Buse JB, Gerstein HC, Probstfield J, et al. Effects of combination lipid therapy in type 2 diabetes mellitus. *N Engl J Med*. 2010;362:1563–74.
- GM D-T, Franssen R, Mooij HL, Visser ME, Hassing HC, Peelman F, Kastelein JJ, Péterfy M, Nieuwdorp M. The metabolism of triglyceride-rich lipoproteins revisited: new players, new insight. *Atherosclerosis*. 2010;211:1–8.
- Gordon SM, Deng J, Lu LJ, Davidson WS. Proteomic characterization of human plasma high density lipoprotein fractionated by gel filtration chromatography. *J Proteome Res*. 2010;9:5239–49.
- Grefhorst A, Elzinga BM, Voshol PJ, Plösch T, Kok T, Bloks VW, van der Sluijs FH, Havekes LM, Romijn JA, Verkade HJ, Kuipers F. Stimulation of lipogenesis by pharmacological activation of the liver X receptor leads to production of large, triglyceride-rich very low density lipoprotein particles. *J Biol Chem*. 2002;277(37):34182–90.
- Haffner SM. Management of dyslipidemia in adults with diabetes (technical review). *Diabetes Care*. 1998;21:160–78.
- Haffner SM, Lehto S, Ronnema T, Pyörala K, Laakso M. Mortality from coronary heart disease in subjects with type 2 diabetes and in nondiabetic subjects with and without prior myocardial infarctions. *N Engl J Med*. 1998;339:229–34.
- Hansen M, Sonne DP, Mikkelsen KH, Gluud LL, Vilsbøll T, Knop FK. Bile acid sequestrants for glycemic control in patients with type 2 diabetes: a systematic review with meta-analysis of randomized controlled trials. *J Diabetes Complications*. 2017;31:918–27.
- Horowitz BS, Goldberg IJ, Merab J, Vanni T, Ramakrishnan R, Ginsberg HN. Increased plasma and renal clearance of an exchangeable pool of apolipoprotein A-I in subjects with low levels of high density lipoprotein cholesterol. *J Clin Invest*. 1993;91:1743–176.
- Horton JD, Shimano H, Hamilton RL, Brown MS, Goldstein JL. Disruption of LDL receptor gene in transgenic SREBP-1a mice unmasks hyperlipidemia resulting from production of lipid-rich VLDL. *J Clin Invest*. 1999;103:1067–76.
- Kannel WB, D'Agostino RB, Wilson PWF, Bleanger AJ, Gagnon DR. Diabetes, fibrinogen, and risk of cardiovascular disease: the Framingham experience. *Am Heart J*. 1990;120:672–6.
- Kearney PM, Blackwell L, Collins R, Keech A, Simes J, Peto R, Armitage J, Baigent C. Efficacy of cholesterol-lowering therapy in 18, 686 people with diabetes in 14 randomised trials of statins: a meta-analysis. *Lancet*. 2008;371:117–25.
- Keech A, Simes RJ, Barter P. Effects of long-term fenofibrate therapy on cardiovascular events in 9795 people with type 2 diabetes mellitus (the FIELD study): randomised controlled trial. *Lancet*. 2005;366:1849–61.

- Kissebah AH, Alfarsi S, Evans DJ, Adams PW. Integrated regulation of very low density lipoprotein triglyceride and apolipoprotein-B kinetics in non-insulin-dependent diabetes mellitus. *Diabetes*. 1982;31:217–25.
- Kobayashi J, Miyashita K, Nakajima K, Mabuchi H. Hepatic lipase: a comprehensive view of its role on plasma lipid and lipoprotein metabolism. *J Atheroscler Thromb*. 2015;22:1001–11.
- Landray MJ, Haynes R, Hopewell JC, Parish S, Aung T, Tomson J, Wallendszus K, Craig M, Jiang L, Collins R, et al. Effects of extended-release niacin with laropiprant in high-risk patients. *N Engl J Med*. 2014;371:203–12.
- Lewis GF, Uffelman KD, Szeto LW, Weller B, Steiner G. Interaction between free fatty acids and insulin in the acute control of very low density lipoprotein production in humans. *J Clin Invest*. 1995;95:158–66.
- Liu J, Hernandez-Ono A, Graham MJ, Galton VA, Ginsberg HN. Type 1 deiodinase regulates ApoA-I gene expression and ApoA-I synthesis independent of thyroid hormone signaling. *Arterioscler Thromb Vasc Biol*. 2016;36:1356–66.
- Low Wang CC, Hess CN, Hiatt WR, Goldfine AB. Clinical update: cardiovascular disease in diabetes mellitus: atherosclerotic cardiovascular disease and heart failure in type 2 diabetes mellitus – mechanisms, management, and clinical considerations. *Circulation*. 2016;133:2459–502.
- Ma W, Wu JH, Wang Q, Lemaitre RN, Mukamal KJ, Djoussé L, King IB, Song X, Biggs ML, Delaney JA, et al. Prospective association of fatty acids in the de novo lipogenesis pathway with risk of type 2 diabetes: the Cardiovascular Health Study. *Am J Clin Nutr*. 2015;101:153–63.
- Silverman MG, Ference BA, Im K, Wiviott SD, Giugliano RP, Grundy SM, Braunwald E, Sabatine MS. Association between lowering LDL-C and cardiovascular risk reduction among different therapeutic interventions: a systematic review and meta-analysis. *JAMA*. 2016;316(12):1289–97. <https://doi.org/10.1001/jama.2016.13985>.
- Moon BC, Hernandez-Ono A, Stiles B, Wu H, Ginsberg HN. Very low density lipoprotein apolipoprotein B secretion is regulated by hepatic triglyceride, and not insulin, in the liver-specific PTEN knockout mouse, a model of increased hepatic insulin signaling. *Arterioscler Thromb Vasc Biol*. 2012;32:236–46.
- Nagashima K, Lopez C, Donovan D, Ngai C, Fontanez N, Bensadoun A, Fruchart-Najib J, Holleran S, Cohn JS, Ramakrishnan R, et al. Effects of the PPAR agonist pioglitazone on lipoprotein metabolism in patients with type 2 diabetes mellitus. *J Clin Invest*. 2005;115:1323–32.
- National Cholesterol Education Program. Third report of the National Cholesterol Education Program (NCEP) expert panel on detection, evaluation, and treatment of high blood cholesterol in adults (Adult Treatment Panel III) final report. *Circulation*. 2002;106:3143–421.
- Olivecrona G. Role of lipoprotein lipase in lipid metabolism. *Curr Opin Lipidol*. 2016;27:233–41.
- Ray KK, Landmesser U, Leiter LA, Kallend D, Dufour R, Karakas M, Hall T, Troquay RP, Turner T, Visseren FL, Wijngaard P, Wright RS, Kastelein JJ. Inclisiran in patients at high cardiovascular risk with elevated LDL cholesterol. *N Engl J Med*. 2017;376:1430–40.
- Riemens S, van Tol A, Sluiter W, Dullaart R. Elevated plasma cholesteryl ester transfer in NIDDM: relationships with apolipoprotein B-containing lipoproteins and phospholipid transfer protein. *Atherosclerosis*. 1998;140:71–9.
- Robinson JG, Farnier M, Krempf M, Bergeron J, Luc G, Averna M, Stroes ES, Langslet G, Raal FJ, El SM, et al. Efficacy and safety of alirocumab in reducing lipids and cardiovascular events. *N Engl J Med*. 2015;372:1489–99.
- Rubins HB, Robins SJ, Collins D, Fye CL, Anderson JW, Elam MB, Faas FH, Linares E, Schaefer EJ, Schectman G, et al. Gemfibrozil for the secondary prevention of coronary heart disease in men with low levels of high-density lipoprotein cholesterol. Veterans Affairs High-Density Lipoprotein Cholesterol Intervention Trial Study Group. *N Engl J Med*. 1999;341:410–8.
- Ryden L, Standl E, Bartnik M, The Task Force on Diabetes and Cardiovascular Diseases of the European Society of Cardiology (ESC) and the European Association for the Study of Diabetes (EASD), et al. Guidelines on diabetes, pre-diabetes, and cardiovascular diseases: executive summary. *Eur Heart J*. 2007;28:88–136.

- Sabatine MS, Giugliano RP, Wiviott SD, Raal FJ, Blom DJ, Robinson J, Ballantyne CM, Somaratne R, Legg J, Wasserman SM, et al. Efficacy and safety of evolocumab in reducing lipids and cardiovascular events. *N Engl J Med.* 2015;372:1500–9.
- Sabatine MS, Giugliano RP, Keech AC, Honarpour N, Wiviott SD, Murphy SA, Kuder JF, Wang H, Liu T, Wasserman SM, Sever PS, Pedersen TR, FOURIER Steering Committee and Investigators. Evolocumab and clinical outcomes in patients with cardiovascular disease. *N Engl J Med.* 2017a;376:1713–22.
- Sabatine MS, Leiter LA, Wiviott SD, Giugliano RP, Deedwania P, De Ferrari GM, Murphy SA, Kuder JF, Gouni-Berthold I, Lewis BS, Handelsman Y, Pineda AL, Honarpour N, Keech AC, Sever PS, Pedersen TR. Cardiovascular safety and efficacy of the PCSK9 inhibitor evolocumab in patients with and without diabetes and the effect of evolocumab on glycaemia and risk of new-onset diabetes: a prespecified analysis of the FOURIER randomised controlled trial. *Lancet Diabetes Endocrinol.* 2017b;5:941–50.
- Schwartz GG, Bessac L, Berdan LG, Bhatt DL, Bittner V, Diaz R, Goodman SG, Hanotin C, Harrington RA, Jukema JW, Mahaffey KW, Moryusef A, Pordy R, Roe MT, Rorick T, Sasiela WJ, Shirodaria C, Szarek M, Tamby JF, Tricoci P, White H, Zeiher A, Steg PG. Effect of alirocumab, a monoclonal antibody to PCSK9, on long-term cardiovascular outcomes following acute coronary syndromes: rationale and design of the ODYSSEY outcomes trial. *Am Heart J.* 2014;168(5):682–9.
- Scott R, O'Brien R, Fulcher G, Pardy C, D'Emden M, Tse D, Taskinen MR, Ehnholm C, Keech A. Effects of fenofibrate treatment of cardiovascular disease risk in 9,795 individuals with type 2 diabetes and various components of the metabolic syndrome: the Fenofibrate Intervention and Event Lowering in Diabetes study. *Diabetes Care.* 2009;32:493–8.
- Seidah NG. The proprotein convertases, 20 years later. *Methods Mol Biol.* 2011;768:23–57.
- Shen WJ, Azhar S, Kraemer FB. SR-B1: a unique multifunctional receptor for cholesterol influx and efflux. *Annu Rev Physiol.* 2017. <https://doi.org/10.1146/annurev-physiol-021317-121550>.
- Stone NJ, Robinson J, Lichtenstein AH, Bairey Merz CN, Lloyd-Jones DM, Blum CB, McBride P, Eckel RH, Schwartz JS, Goldberg AC, et al. 2013 ACC/AHA guideline on the treatment of blood cholesterol to reduce atherosclerotic cardiovascular risk in adults: a report of the American College of Cardiology/American Heart Association Task Force on Practice Guidelines. *J Am Coll Cardiol.* 2014;63(25 Pt B):2889–934.
- Tall AR, Rader DJ. Trials and tribulations of CETP inhibitors. *Circ Res.* 2018;122:106–12.
- Taskinen M-R. Hyperlipidaemia in diabetes. In: Betteridge DJ, editor. *Bailliere's Clinical endocrinology and metabolism*, vol. 4. London: Bailliere, Tindall; 1990. p. 743–75.
- Timmins JM, Lee JY, Boudyguina E, Kluckman KD, Brunham LR, Mulya A, Gebre AK, Coutinho JM, Colvin PL, Smith TL, Hayden MR, Maeda N, Parks JS. Targeted inactivation of hepatic Abca1 causes profound hypoalphalipoproteinemia and kidney hypercatabolism of apoA-I. *J Clin Invest.* 2005;115:1333–42.
- Trigatti B, Rigotti A, Krieger M. The role of the high-density lipoprotein receptor SR-B1 in cholesterol metabolism. *Curr Opin Lipidol.* 2000;11:123–31.
- Zhang Y-L, Hernandez-Ono A, Ko C, Yasunaga K, Huang L-S, Ginsberg HN. Regulation of hepatic apolipoprotein B-lipoprotein assembly and secretion by the availability of fatty acids 1: differential effects of delivering fatty acids via albumin or remnant-like emulsion particles. *J Biol Chem.* 2004;279:19362–74.



# Metabolic Syndrome

# 3

Scott M. Grundy

## Contents

Introduction .....	72
Proposed Underlying Causes of Metabolic Syndrome .....	75
Insulin Resistance .....	75
Obesity .....	75
Overnutrition and Energy Imbalance .....	76
Effects of Overnutrition on Specific Tissues .....	78
Adipose Tissue .....	78
Pancreatic Beta Cells .....	81
Skeletal Muscle .....	81
Liver .....	86
Kidney .....	88
Heart .....	88
Adverse Effects of Carbohydrate Overnutrition .....	88
Timeline for Development of the Metabolic Syndrome .....	91
Obesity Without Metabolic Syndrome .....	91
Metabolic Syndrome Without Obesity .....	92
Lifestyle Intervention on Metabolic Syndrome .....	92
Management of Individual Metabolic Risk Factors .....	93
Atherogenic Dyslipidemia .....	93
Hypertension .....	94
Hyperglycemia .....	94
Pro-inflammatory State .....	95
Prothrombotic State .....	95
References .....	95

---

S. M. Grundy (✉)  
Center for Human Nutrition and Department of Internal Medicine, UT Southwestern Medical  
Center, Dallas, TX, USA

Veterans Affairs Medical Center, Dallas, TX, USA  
e-mail: [scott.grundy@utsouthwestern.edu](mailto:scott.grundy@utsouthwestern.edu)

---

**Abstract**

The metabolic syndrome is a multiple risk factor complex for atherosclerotic cardiovascular disease (ASCVD). These risk factors consist of atherogenic dyslipidemia, elevated blood pressure, elevated plasma glucose, a prothrombotic state, and a pro-inflammatory state. The presence of the metabolic syndrome doubles the risk for ASCVD and causes a fivefold increase in the risk for type 2 diabetes. Multiple factors contribute to the syndrome. The most important is overnutrition combined with catabolic defects in individual risk parameters. The accumulation of ectopic lipid in target tissues appears to be a common denominator in risk factor development. Most individuals with metabolic syndrome exhibit insulin resistance, and most also manifest upper body obesity. Both these abnormalities are produced largely by overnutrition. Primary management of metabolic syndrome is caloric restriction combined with increased physical activity. If this approach does not eliminate affected risk factors, consideration must be given to the use of drug therapies to treat individual risk factors.

---

**Keywords**

Metabolic syndrome · Type 2 diabetes · Insulin resistance · Ectopic fat · Overnutrition

---

**Introduction**

The metabolic syndrome is a multiplex risk factor for atherosclerotic cardiovascular disease (ASCVD) (National Cholesterol Education Program ATP III 2002; Grundy et al. 2005; Grundy 2007; Alberti et al. 2009; Sattar et al. 2003; Kazlauskienė et al. 2015; Hajat and Shather 2012). Meta-analyses show that the presence of metabolic syndrome essentially doubles the risk for ASCVD (Hu et al. 2004; Gami et al. 2007; Mottillo et al. 2010). The condition is a strong predictor of type 2 diabetes (Klein et al. 2002; Lorenzo et al. 2003; Barden et al. 2013; Carlsson et al. 2014), and individuals with diabetes are susceptible for developing both macrovascular disease (ASCVD) (Miettinen and Salomaa 1997; Vinik and Flemmer 2002) and microvascular disease (Nathan 2015; Park 2014; Lee et al. 2015). The prevalence of metabolic syndrome throughout the world is relatively high – ranging from 10% to 40%, depending on the population (Grundy 2008). This high prevalence is largely due to the worldwide epidemic of obesity and sedentary life habits (Ng et al. 2014).

Five cardiovascular risk factors make up the metabolic syndrome: atherogenic dyslipidemia, elevated blood pressure, elevated plasma glucose, a prothrombotic state, and a pro-inflammatory state (National Cholesterol Education Program ATP III 2002; Grundy et al. 2005). Atherogenic dyslipidemia consists of elevated serum triglycerides (TG), elevated apolipoprotein B (apo B), and reduced levels of high-density lipoprotein cholesterol (HDL-C). Hypertension can be borderline or clinically categorical. Dysglycemia comprises both prediabetes and diabetes. A prothrombotic state consists of abnormalities in coagulation factors and/or



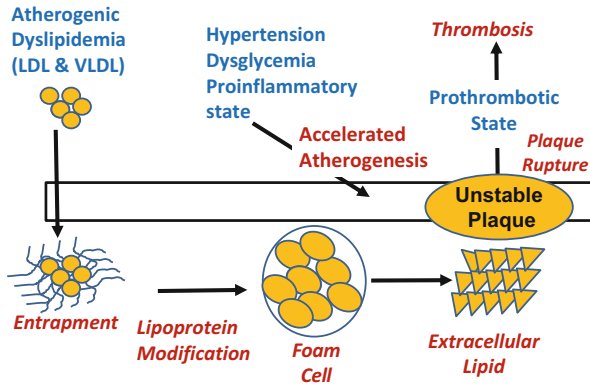

**Fig. 1** Metabolic syndrome and atherosclerotic cardiovascular disease. Elevations of low-density lipoprotein (LDL) and very low-density lipoprotein (VLDL) are the primary abnormality in atherogenesis. These lipoproteins filter through the arterial media and are entrapped in the subendothelial space. They undergo various chemical modifications and are engulfed by macrophages or smooth muscle cells to form lipid-rich foam cells. The resulting lesion is the fatty streak. Eventually foam cells are degraded and release cholesterol into the extracellular space. At the same time, connective tissue is deposited. The resulting lesion is called a fibro-fatty plaque. The formation of this plaque is accelerated by hypertension, dysglycemia, and inflammatory mediators. Some fibro-fatty plaques become unstable and are prone to rupture. When this occurs, a thrombotic event is likely to result. The likelihood of forming a large thrombus is enhanced in patients who carry a prothrombotic state

blood platelets. A pro-inflammatory state is reflected by elevations of inflammatory mediators. When these risk factors aggregate, they double the risk for ASCVD (Hu et al. 2004; Gami et al. 2007; Mottillo et al. 2010).

All of the metabolic risk factors appear to promote arterial disease. They act at one step or another in the pathogenesis of atherosclerosis or its complications (Fig. 1). The dominant risk factor is atherogenic dyslipidemia, which consists largely of elevated apolipoprotein B-containing lipoproteins. These lipoproteins filter into the subendothelial space of arteries and become entrapped in a mesh of glycosaminoglycans (Williams and Tabas 1995; Devlin et al. 2008). Here they undergo several modifications that allow for their uptake by macrophages or smooth muscle cells. These cells become engorged with lipid and are called foam cells. Eventually, foam cells undergo apoptosis and release cholesterol into the subendothelial space. The resulting lipid-rich plaque can become unstable and hence predisposed to plaque rupture (Felton et al. 1997; Kolodgie et al. 2003). When rupture happens, an occlusive thrombosis can supervene. This entire process can proceed through the action of atherogenic lipoproteins alone, but it typically is accelerated by the other metabolic risk factors. The details whereby these risk factors affect atherogenesis, induce plaque instability, and cause obstructive thrombosis are not fully understood. But, there is little doubt that combined they can act together to enhance the likelihood of acute cardiovascular events.

**Table 1** Criteria for clinical diagnosis of the metabolic syndrome

Measure	Categorical cut points
Elevated waist circumference <sup>a</sup>	Population- and country-specific definitions
Elevated triglycerides (drug treatment for elevated triglycerides is an alternate indicator <sup>b</sup> )	≥150 mg/dL (1.7 mmol/L)
Reduced HDL-C (drug treatment for reduced HDL-C is an alternate indicator <sup>b</sup> )	<40 mg/dL (1.0 mmol/L) in males; <50 mg/dL (1.3 mmol/L) in females
Elevated blood pressure (antihypertensive drug treatment in a patient with a history of hypertension is an alternate indicator)	Systolic ≥130 and/or diastolic ≥85 mm Hg
Elevated fasting glucose <sup>c</sup> (drug treatment of elevated glucose is an alternate indicator)	≥100 mg/dL

HDL-C indicates high-density lipoprotein cholesterol

<sup>a</sup>It is recommended that the IDF cut points be used for non-Europeans and either the International Diabetes Federation (IDF) or American Heart Association/National Heart, Lung, and Blood Institute (AHA/NHLBI) cut points be used for people of European origin until more data are available

<sup>b</sup>The most commonly used drugs for elevated triglycerides and reduced HDL-C are fibrates and nicotinic acid. A patient taking one of these drugs can be presumed to have high triglycerides and low HDL-C. High dose of  $\omega$ -3 fatty acids presumes high triglycerides

<sup>c</sup>Most patients with type 2 diabetes mellitus will have the metabolic syndrome by the proposed criteria

Over the past two decades, several clinical definitions of metabolic syndrome have been proposed (Grundy et al. 2005). These recently have been unified into a widely accepted consensus definition (Table 1) (Alberti et al. 2009). The latter includes abdominal obesity as a key (but not necessary) component. Other factors consist of elevations in serum triglycerides and glucose, increased blood pressure, and reduced levels of HDL-C. The presence of three or more of these factors constitutes a diagnosis of metabolic syndrome. According to this consensus definition, abdominal obesity is identified by increased waist circumference. Available evidence suggests that appropriate waist circumference cut points vary according to population (Table 2) (Alberti et al. 2009).

Although most investigators agree that metabolic risk factors tend to cluster together, some researchers question the practical utility of a clinical diagnosis, such as shown in Tables 1 and 2 (Simmons et al. 2010). These workers offer several caveats for its use. For example, they visualize metabolic syndrome as a premorbid condition. They believe the syndrome should not extend to patients with established diabetes or ASCVD. Further, since each metabolic risk factor should receive separate attention, they see no advantages for aggregating them into a syndrome.

According to a contrary view, metabolic syndrome is a useful clinical entity. For example, multiple risk factors can have common underlying causes that are potential targets for single interventions (e.g., lifestyle modification). Moreover, these risk factors persist in persons with diabetes and ASCVD; therefore, the underlying causes should continue to be therapeutic targets, even after clinical diseases develop, and, importantly, the metabolic syndrome confers multiplicative risk for ASCVD, i.e., more risk than imparted by summation of individual risk factors. This heightened risk is not apparent when attention is given exclusively to individual risk factors.

**Table 2** Current recommended waist circumference thresholds for abdominal obesity by organization

Recommended waist circumference threshold for abdominal obesity		
Population	Women	Men
Europid	≥80 cm	≥94 cm
Caucasian	≥80 cm (increased risk) ≥88 cm (still higher risk)	≥94 cm (increased risk) ≥102 cm (still higher risk)
American	≥88 cm	≥102 cm
Canadian	≥88 cm	≥102 cm
European	≥88 cm	≥102 cm
Asian (including Japanese)	≥80 cm	≥90 cm
Asian	≥80 cm	≥90 cm
Japanese	≥90 cm	≥85 cm
Chinese	≥80 cm	≥85 cm
Middle Easterner, Mediterranean	≥80 cm	≥94 cm
Sub-Saharan African	≥80 cm	≥94 cm
Ethnic central and south American	≥80 cm	≥90 cm

## Proposed Underlying Causes of Metabolic Syndrome

### Insulin Resistance

One theory holds that insulin resistance causes the metabolic syndrome (Reaven 1988, 2005, 2011). Without doubt, insulin resistance associates with most of the metabolic risk factors (Reaven 2005). Several mechanisms have been postulated to explain the relation between skeletal-muscle insulin resistance and risk factors (Jornayvaz et al. 2010; Shulman 2014a; Samuel and Shulman 2016). For example, insulin resistance in the muscle seemingly contributes directly to hyperglycemia and indirectly to atherogenic dyslipidemia. The latter could result from diversion of dietary carbohydrate to the liver; this diversion initiates de novo lipogenesis in the liver, which promotes dyslipidemia. Insulin resistance commonly associates with hypertension, and a variety of causative mechanisms have been proposed to account for this relationship (Reaven 1991).

### Obesity

The metabolic syndrome occurs most commonly in persons who are categorically obese (BMI ≥30 kg/m<sup>2</sup>) (Park et al. 2003; Grundy et al. 2014). It occurs less often in those who are overweight (BMI 25–29.9 kg/m<sup>2</sup>) and is relatively rare in normal-weight individuals (Park et al. 2003). Persons with upper body obesity are particularly susceptible (Jensen 2006; Tan et al. 2004). Upper body obesity consists of excess fat in adipose tissue of upper body subcutaneous and visceral pools or, most commonly,

in both. Men generally have more upper body obesity than women (Vega et al. 2006; Grundy et al. 2013). This difference is not exclusive; some women have upper body obesity and are especially prone to metabolic syndrome (Peiris et al. 1988; Bjorntorp 1990, 1996).

One link between obesity and metabolic syndrome may be through high levels of nonesterified fatty acids (NEFA); the latter result from increased lipolysis occurring in adipose tissue (Boden 2011). Individuals with upper body obesity generally express higher plasma NEFA levels than do those with lower body obesity (Jensen et al. 1989). High NEFA levels strongly associate with an accumulation of lipid in various organs or tissues, especially the muscle and liver. This accumulation is referred to as ectopic fat (or lipid) (Shulman 2014b). Ectopic lipid in skeletal muscle apparently induces muscle insulin resistance. In the liver, ectopic lipid equates to nonalcoholic fatty liver disease (NAFLD) and predisposes to hepatic insulin resistance, increased hepatic glucose output, and atherogenic dyslipidemia (Vatner et al. 2015).

## Overnutrition and Energy Imbalance

Overconsumption of nutrient energy is another potential cause of metabolic syndrome. It can be a source of ectopic lipid, which results from imbalance between the delivery of nutrients to tissues (or organs) and removal through oxidation. An excessive intake of either dietary fat or carbohydrate can bring about ectopic lipid. Tissue accumulation of lipid presumably initiates metabolic stress that drives the development of risk factors (Grundy 2015). The molecular mechanisms whereby ectopic lipid elicits metabolic risk factors may be manifold. In some instances, accumulation of triglyceride may be detrimental, and beyond tissue triglyceride itself, excess lipid may reflect either abnormally high flux of nutrients into and through metabolic pathways or the presence of bioactive lipids (e.g., diacylglycerol [DAG] or ceramides) that induce insulin resistance or inflammatory processes.

A review of triglyceride metabolism may help to inform the origins of ectopic lipid (Fig. 2). Ingested (fat) triglyceride is hydrolyzed in the gut, re-esterified into triglyceride in enterocytes, and incorporated into chylomicrons. In the circulation, chylomicron triglyceride is hydrolyzed by lipoprotein lipase (LPL), this enzyme is located on capillary endothelial cells. Fatty acids, released by LPL, are removed largely by adipose tissue. Here they undergo reesterification into triglyceride. Adipose tissue triglyceride is held in reserve for subsequent release as fatty acids during the fasting state. Of note, all fatty acids released during chylomicron lipolysis are not taken up by adipose tissue. About one-fourth of these fatty acids spill over into the circulation where they are taken up by the liver and other tissues (Almandoz et al. 2013). The liver also produces a triglyceride-rich lipoprotein called very low-density lipoprotein (VLDL). This lipoprotein is metabolized similarly to that of chylomicrons. It also is a precursor of low-density lipoprotein (LDL).

Another source of ectopic lipid is *de novo* lipogenesis from carbohydrate. During intake of excess carbohydrate, hyperinsulinemia stimulates the synthesis

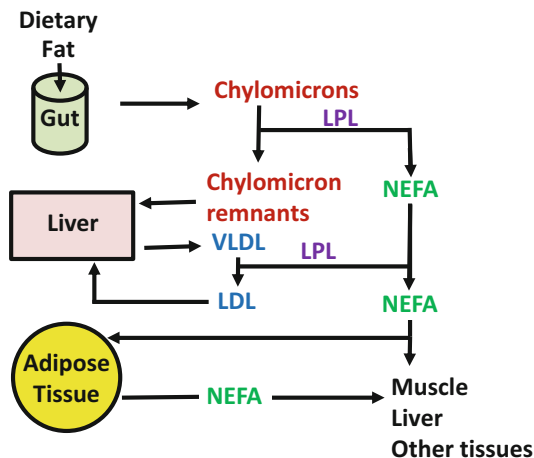
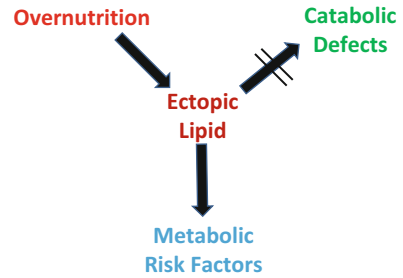

**Fig. 2** Pathways of triglyceride and fatty acid metabolism. Ingested fat (triglyceride) is incorporated into chylomicrons that pass through lymphatics to the general circulation. Triglycerides undergo hydrolysis by lipoprotein lipase (LPL) to release nonesterified fatty acids (NEFA). These are taken up predominantly by adipose tissue but also by muscle, liver, and other tissues. Fatty acids can enter the liver from chylomicron remnants. The liver secretes triglyceride-rich very low density lipoprotein, which also undergo lipolysis by LPL. In the process, VLDL is transformed into cholesterol-enriched low-density lipoprotein (LDL). Adipose tissue is the major storage site for triglyceride. It also serves as a source of metabolic fuel by releasing NEFA into the circulation for uptake by various tissues

of fatty acids in the liver and other tissues. Insulin's stimulatory action is mediated by transcription factor, sterol regulatory element-binding protein 1c (SREBP-1c), which dictates the synthesis of enzymes involved in fatty acid synthesis (Shimomura et al. 2000). A high input of glucose into the liver also enhances the activity of carbohydrate-responsive element-binding protein (ChREBP); this action likewise stimulates the synthesis of fatty acids via control of key genes of the lipogenic pathway, i.e., fatty acid synthase and acetyl-CoA carboxylase (Uyeda et al. 2002).

In a metabolic steady state, adipose tissue pools of triglyceride are constant; hence, oxidation rates of fatty acids, and glucose for that matter, equal their intakes. Imbalance between nutrient intake and oxidation occurs only during weight gain or loss. At constant body weight, obese people consume and dispose of more nutrient energy than nonobese persons (Welle et al. 1992; Swinburn et al. 2009). In obese individuals, balancing energy intake and expenditure is facilitated by expansion of lean body mass (Swinburn et al. 2009). During weight gain, increases in lean body mass roughly equal increments in fat mass (Tulloch-Reid et al. 2003). Much of the increase in lean mass occurs in skeletal muscle (Forbes 1993; Albu et al. 2005), but other organs become enlarged too (Leon et al. 2013). The rise in lean mass with overnutrition helps to buffer against ectopic lipid. But in many obese persons, a higher energy intake puts a strain on oxidative capacity, which predisposes to ectopic lipid.

**Fig. 3** Hypothesis for origin of metabolic risk factors. The accumulation of ectopic lipid in various tissues potentially results in the development of risk factors. Ectopic lipid can be explained by the combination of overnutrition and defective catabolism of nutrients in particular tissues



*Genetics.* Susceptibility to the metabolic syndrome varies from one person to another (Grundy et al. 2014). Thus, genetic factors seemingly modify the response to overnutrition. Several genome-wide association studies are in accord (Stirnadel et al. 2008; Fall and Ingelsson 2014; Norris and Rich 2012; Rankinen et al. 2015). Genetic disorders of adipose tissue, notably familial forms of lipodystrophy, strongly associate with metabolic syndrome (Garg 2004; Garg and Misra 2004; Decaudain et al. 2007). Beyond lipodystrophies, a host of other genetic factors influence metabolic risk factors. It is well known that the coexistence of overnutrition and genetic variation can combine to elicit one or another risk factor (Nie et al. 1998; Romeo et al. 2008; Gehrlich 1999). As already noted, metabolic risk factors most often occur when nutrient intake exceeds energy disposal capacity.

Figure 3 shows a simple hypothesis for the development of metabolic risk factors. Genetic abnormalities in oxidative mechanisms likely cause catabolic defects, which combined with overnutrition induce metabolic syndrome (Petersen et al. 2012); similarly, catabolic defects acquired with aging likewise can contribute to the syndrome (Petersen et al. 2015). But generally speaking, in the absence of overnutrition, overt metabolic risk factors are uncommon despite the presence of catabolic defects (Petersen et al. 2012, 2015).

In the discussion to follow, the responses of specific tissues to overnutrition will be examined for their contributions to metabolic risk factors.

---

## Effects of Overnutrition on Specific Tissues

### Adipose Tissue

It is well known that accumulation of excess fat in adipose tissue is commonly associated with abnormalities in whole-body metabolism. An important question is whether this association is causal. Indeed, the expansion of adipose tissue could protect against accumulation of ectopic lipid in other tissues (Kim et al. 2007; Manolopoulos et al. 2010). If so, metabolic syndrome theoretically could result from insufficient adipose tissue needed to cope with overnutrition. The beneficial effect of adipose tissue is best exemplified by the rare disorder called lipodystrophy (Garg and Misra 2004; Huang-Doran et al. 2010). Patients with lipodystrophy have

severe deficiency of adipose tissue. They are unable to store excess nutrients and are susceptible to ectopic lipid in other tissues. By analogy, even in the presence of obesity, the metabolic syndrome could occur when storage capacity of adipose tissue is exceeded. On the other hand, excess adipose tissue per se could be detrimental, as commonly believed.

Adipose tissue modulates the timing of energy homeostasis by releasing NEFA when they are needed for energy by other tissues. Plasma insulin regulates NEFA release. During fasting, insulin levels fall and more NEFA enter the circulation. In a steady state, the 24-h release of NEFA equals the rate of adipose tissue uptake of fatty acids. As already noted, these fatty acids come from chylomicrons and/or VLDL (Fig. 2). In obese persons, when caloric intake is high, more fatty acids cycle through adipose tissue. With overnutrition, fasting NEFA levels typically are elevated and represent a potential source of ectopic lipid. In fact, fasting NEFA levels depend more on caloric intake than on the size of adipose tissue pools. Accordingly, with caloric restriction, NEFA levels decline rapidly even when adipose tissue pools remain high (Thomas et al. 2016).

The relation between adipose tissue compartments and metabolic syndrome is a topic of interest. Three major compartments of adipose tissue are upper body subcutaneous, lower body subcutaneous (gluteofemoral), and visceral (Vega et al. 2006; Abate et al. 1994). Figure 4 summarizes apparent magnitudes of flow of fatty acids through each of these compartments.

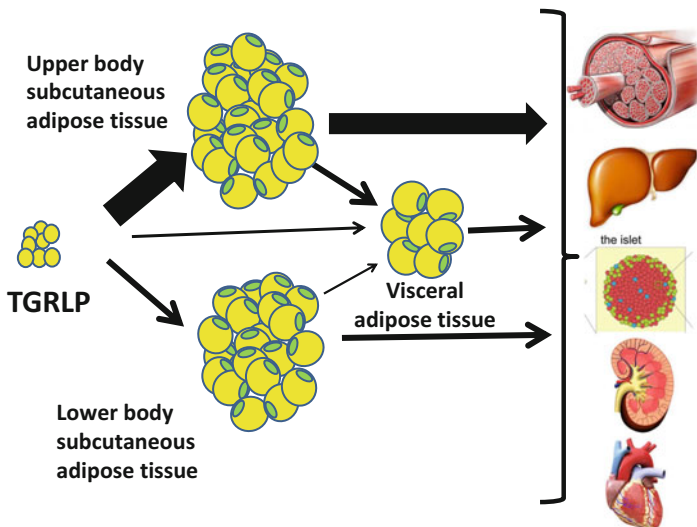

**Fig. 4** Adipose tissue pathways for fatty acids released by hydrolysis of triglyceride in triglyceride-rich lipoproteins (TGRLP). Three major adipose tissue compartments are shown: upper body subcutaneous, lower body subcutaneous, and visceral. The size of the arrows reflects relative magnitudes of fatty acid flux through each pathway. Fatty acids released from each adipose tissue bed potentially reach a variety of tissues

As already noted, upper body obesity is associated more strongly with metabolic syndrome than is lower body obesity (Bjorntorp 1991; Kissebah and Krakower 1994; Jensen 2008). In the upper body, the subcutaneous compartment is 2–4 times larger than the visceral compartment (Grundy et al. 2013). Normally, the former releases more NEFA into both the systemic and splanchnic circulations than does visceral adipose tissue (Guo et al. 1999; Nielsen et al. 2004; Roust and Jensen 1993). In obese individuals, however, visceral adipose tissue can contribute substantially to the splanchnic circulation. Upper body adipose compartments are more insulin resistant than lower body adipose tissue (Krotkiewski et al. 1983; Fried and Kral 1987; Karastergiou et al. 2013). In turn, upper body adipose tissue releases NEFA more readily than does lower body adipose tissue. This means that upper body adipose tissue has a higher turnover rate of fatty acids (Fig. 4) (Jensen et al. 1989).

Visceral obesity has been reported to associate strongly with metabolic syndrome (Bjorntorp 1993; Cefalu et al. 1995; Seidell et al. 1990; Kuk et al. 2006; Matsuzawa et al. 2011; Tchernof and Després 2013; Abate et al. 1995). Of particular note, visceral adipose tissue correlates positively ectopic lipid in the liver (Guerrero et al. 2009). NEFA destined for the liver come from adipose tissue located in the visceral and upper body subcutaneous compartments or directly from splanchnic lipolysis of triglyceride-rich lipoproteins (TGRLP) (Nelson et al. 2007). Thus, although visceral adipose tissue is one source of splanchnic NEFA, it is not the only source. The strong association between visceral obesity and metabolic syndrome may be explained in part by visceral fat's high correlation with upper body subcutaneous fat (Abate et al. 1995; Chandalia et al. 2007). An alternate view holds that visceral obesity results from a deficiency of subcutaneous fat or insufficient total fat storage capacity; the resulting overload of visceral fat could favor accumulation of ectopic lipid in the liver (Després et al. 2008).

Lower body obesity occurs more commonly in women than in men. It accompanies the metabolic syndrome less often than does upper body obesity (Karpe and Pinnick 2015). The reason is not entirely clear. Persons with lower body obesity are reported to have relatively low rates of NEFA release into the circulation (Fig. 4) (Jensen et al. 1989). This suggests a lower caloric intake than that of persons with upper body obesity. Some workers postulate that lower body obesity actually protects against the metabolic syndrome (Karpe and Pinnick 2015). This seems unlikely; it is more likely to be neutral, because its turnover rate of fatty acids is in the normal range (Jensen et al. 1989).

An emerging theory holds that overloading of adipose tissue with triglyceride results in production of abnormal quantities of the so-called *adipokines*. Recent research shows that adipose tissue produces a host of bioactive peptides that may influence metabolic risk factors (Lehr et al. 2012). Examples include adiponectin, interleukin-6, tumor necrosis factor- $\alpha$ , resistin, leptin, angiotensinogen, visfatin, and plasminogen activator inhibitor-1 (PAI-1) (Berg and Scherer 2005). To date, a causative connection between adipokines and metabolic syndrome has not been confirmed, but this potential connection is an intriguing hypothesis.



**Fig. 5** Factors regulating insulin secretion and pancreatic beta cells. Glucose stimulates rapid insulin release through an ATP -K<sup>+</sup> channel-dependent mechanism. Elevations of nonesterified fatty acids (NEFA) amplify and sustain insulin secretion through various pathways (Komatsu et al. 2013)

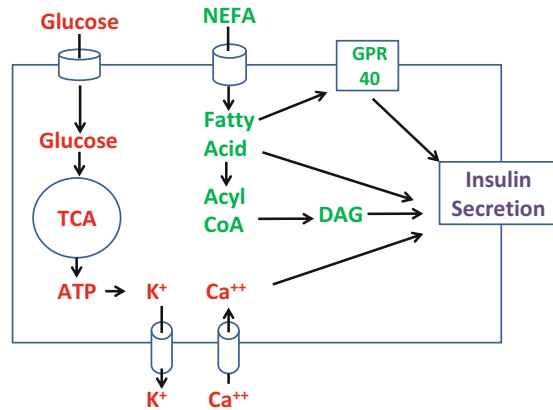

## Pancreatic Beta Cells

With overnutrition, excess nutrients flood pancreatic beta cells. Nutrients include glucose, fatty acids, and amino acids (Fig. 5). In obese individuals, who are consuming excess energy, these nutrients enhance insulin secretion and cause hyperinsulinemia. For example, fatty acids amplify the action of glucose to stimulate insulin secretion (Stein et al. 1996; Dobbins et al. 1998a, b; Boden et al. 1998). In obese, prediabetic animal models, ectopic lipid appears in beta cells (Unger and Zhou 2001). The pancreas contains increased ectopic lipid when diabetes is present (Szczepaniak et al. 2012). Besides stimulating insulin release, ectopic lipid may eventually destroy beta cells – a process known as lipotoxicity (Shimabukuro et al. 1998). Prolonged lipotoxicity may contribute to progressive decline in beta-cell function, which can contribute to the hyperglycemia of type 2 diabetes.

## Skeletal Muscle

Skeletal muscle disposes of at least one-third of consumed energy (Zurlo et al. 1990). Skeletal-muscle pathways used by glucose and lipid are shown in Fig. 6. All nutrients – carbohydrate, lipid, and protein – can serve as energy sources for muscle contraction. Postprandial glucose entering the muscle is either oxidized directly or stored as glycogen. Muscle glycogen is the greatest source of stored glucose in the body. During fasting, glycogen is degraded to glucose as an energy source. In fasting or during exercise, NEFA are another fuel source. Triglyceride, synthesized in the muscle after the uptake of NEFA, is another potential source of energy for the muscle. During exercise, all potential sources of energy are mobilized and degraded to produce high-energy phosphate bonds for muscle contraction. The particular mix of oxidative substrates during exercise depends on several factors including intensity and duration of exercise and the metabolic status of the individual.

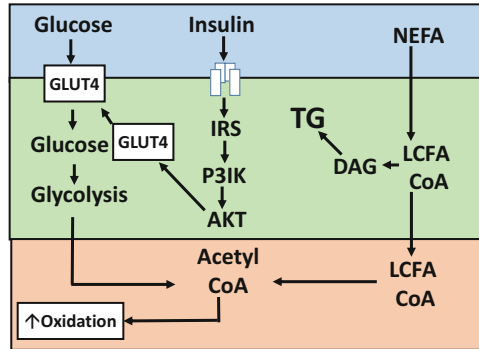

**Fig. 6** Pathways were metabolism of glucose and fatty acids in muscle tissue. Colors signify plasma (blue), cytoplasm (green), and mitochondria (orange). Binding of insulin to the insulin receptor stimulates a cascade of phosphorylation of insulin receptor substrates (IRS), phosphoinositol-3 kinase, and protein kinase B (AKT). This sequence promotes movement of glucose transporter-4 (GLUT4) from the cytoplasm to the cell surface, where it can internalize plasma glucose. The latter undergoes glycolysis in the cytoplasm resulting in the formation of acetyl CoA in the mitochondria. This product undergoes oxidation in the tricarboxylic acid cycle. Plasma NEFA are taken up by muscle cells and are transformed into long-chain fatty acyl CoA (LCFA CoA), which can either be transferred into the mitochondria for beta-oxidation or re-esterified through diacylglycerol (DAG) to triglyceride in the cytoplasm

In patients with type 2 diabetes, metabolic abnormalities in muscle function contribute to hyperglycemia. Amongst these abnormalities, the most important one appears to be a block in the action of insulin that inhibits glucose uptake (insulin resistance). A usual companion to insulin resistance is hyperinsulinemia, which is due to overstimulation of insulin secretion from excess glucose and other nutrients (Fig. 5). Hyperinsulinemia helps to override insulin resistance so as to maintain normoglycemia. In persons who cannot produce sufficient quantities of insulin, insulin resistance becomes dominant, and hyperglycemia develops. The insulin resistance/hyperinsulinemia combination may affect other risk factors. For example, Reaven (1988, 1995, 2003; Reaven et al. 1967) has proposed that hyperinsulinemia underlies hypertriglyceridemia and hypertension in persons with insulin resistance (syndrome X). Other investigators support the contribution of insulin resistance in the muscle to metabolic risk factors (Petersen et al. 2007; DeFronzo and Tripathy 2009).

What are the causes of insulin resistance in skeletal muscle? Several possibilities exist (Fig. 6). For instance, there could be genetic causes. About a decade ago, it was speculated that insulin resistance could result from key genes regulating the insulin signaling pathway. Indeed, several mutations were found that accompanied insulin resistance and type 2 diabetes (Almind et al. 1993; Imai et al. 1994; Esposito et al. 2003; El Mkaem et al. 2001; Semple et al. 2009; Ye et al. 2011). Undoubtedly polymorphisms in genes responsible for the insulin signaling cascade can cause insulin resistance and possibly elicit the metabolic syndrome. However, these polymorphisms do not appear to be a common cause of insulin resistance.

Metabolic defects in muscle mitochondria, leading to impaired oxidation of acetyl CoA, could be another cause of insulin resistance. Reduced oxidative capacity of muscle mitochondria has been reported to promote insulin resistance and associate with type 2 diabetes (Simoneau and Kelley 1997; Kelley et al. 2002; Petersen et al. 2004). Conversely, other workers speculate that decreased mitochondrial oxidation is secondary to defects in cytoplasmic pathways (Hoeks and Schrauwen 2012). But the idea of primary oxidative defects in mitochondria remains attractive (Lowell and Shulman 2005). If mitochondria in persons with insulin resistance are defective, the link between reduced oxidative capacity and insulin resistance could be through backup of lipids in muscle cells. In support, intramyocellular lipid accumulation has been observed in insulin-resistant persons (Sinha et al. 2002; Morino et al. 2005). Some endurance-trained athletes without insulin resistance also show lipid accumulation in myocytes (Goodpaster et al. 2001; van Loon et al. 2004). Intramyocellular lipid content in type 2 diabetes patients and in overweight, sedentary men surprisingly is similar to that noted in highly trained endurance athletes (van Loon et al. 2004). This paradox has not been entirely explained but may relate to differences in intracellular compartmentalization of lipids between endurance trainers and insulin-resistant individuals (Devries et al. 2013).

A host of abnormalities in function or number of muscle mitochondria might exist. Such defects might impair mitochondrial oxidative capacity. The mitochondrial content of the muscle is related to mitochondrial biogenesis. Physical activity increases mitochondrial content (Bishop et al. 2014) and reduces insulin resistance, whereas sedentary habits and aging decrease mitochondrial number and increase insulin resistance (Petersen et al. 2003, 2005). One line of evidence supporting the hypothesis that defective mitochondria can be a direct cause of insulin resistance is that various primary mitochondrial myopathies are associated with reduced insulin sensitivity (Rue et al. 2014).

Muscle insulin resistance may also occur from the entrance of external stimuli in otherwise normal muscle. For example, muscle uptake of excess circulating NEFA seems to underlie much of insulin resistance. For instance, when intravenous fat emulsions are infused with heparin to raise NEFA levels, insulin resistance rapidly develops in the muscle (Boden et al. 1995).

A mechanism whereby elevations in circulating NEFA impair glucose utilization in muscle was first proposed by Philip Randle and associates (Randle et al. 1963). The following summarizes this so-called Randle hypothesis (Fig. 7a). The essential concept is that beta-oxidation of excess fatty acids overloads mitochondria with acetyl CoA; this excess reduces glucose oxidation by inhibiting pyruvate dehydrogenase (PDH). Excess acetyl CoA further drives citrate synthesis, and it is transferred to save the cytoplasm. A coordinated inhibition of glycolytic flux mediated by the effects of citrate on phosphofructokinase-1 and phosphofructokinase-2 may impair glucose uptake (Randle et al. 1994). The Randle hypothesis in essence describes a mechanism whereby the muscle preferentially metabolizes one nutrient (fatty acid) over another (glucose). This is attractive but remains to be confirmed. The pathways whereby excess beta-oxidation of fatty acids inhibits PDH have not been convincingly demonstrated. By the same token, if beta-oxidation inhibits glycolysis, a link between an excess of glucose-6-phosphate and glucose uptake by the muscle has not been confirmed.

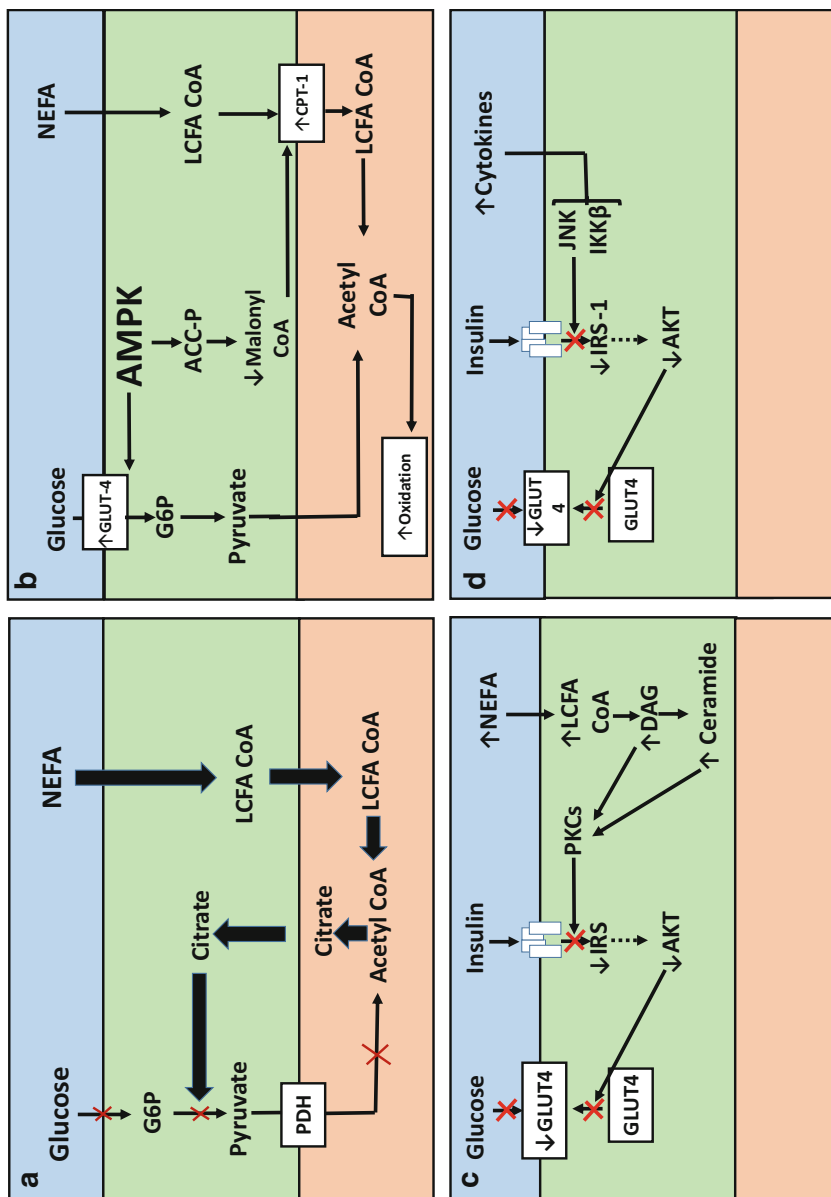

**Fig. 7** Theories of insulin resistance. A. Randle hypothesis or glucose-fatty acid cycle. According to this hypothesis, high levels of NEFA result in excess acetyl CoA in mitochondria that inhibit the action of pyruvate dehydrogenase (PDH). At the same time, excess citrate is returned to the cytoplasm, which inhibits

Since the Randle hypothesis was proposed, several investigators have supported it or variations of it (Ruderman et al. 1999; Hue and Taegtmeyer 2009). But other workers have not been able to show that fatty acid oxidation per se inhibits glucose oxidation (Wolfe 1998). In a related area, Ruderman and colleagues (Richter and Ruderman 2009; Ruderman et al. 2013) have postulated that AMP-activated protein kinase (AMPK) plays a key regulatory role in modulating energy balance in skeletal muscle (Fig. 7b). They speculate that dysregulation of AMPK is an important factor in the development of insulin resistance and the metabolic syndrome. Most of the evidence for a role for AMPK dysregulation in causation of the metabolic syndrome comes from reports that activation of AMPK promotes glucose uptake by the muscle and enhances fatty acid oxidation (Fryer et al. 2002; Zheng et al. 2001; Winder et al. 2000; Winder et al. 1990). It is clear that AMPK is an important metabolic regulator. It phosphorylates acetyl-CoA carboxylase 2 (ACC2), which is the rate-limiting enzyme controlling synthesis of malonyl CoA. In turn, malonyl CoA regulates the transfer of fatty acids into the mitochondria for oxidation. Thus, high levels of malonyl CoA can block the transfer of fatty acids into the mitochondria, resulting in the accumulation of fatty acids and triglyceride in the cytoplasm. In persons with type 2 diabetes, muscle levels of malonyl CoA have been noted to be increased (Båvenholm et al. 2003). Such abnormalities could contribute to insulin resistance by mechanisms described in the foregoing. Whether dysfunction of AMPK contributes to metabolic syndrome in humans is unclear, but since AMPK is a master regulator of metabolism, its dysfunction could contribute to insulin resistance in several ways (Steinberg and Kemp 2009).

More recently another theory has been proposed whereby fatty acids in muscle impair glucose uptake in response to insulin (Fig. 7c). In brief, the uptake of fatty acids into the muscle leads to increased cytosolic diacylglycerol (DAG) and ceramide; these increases activate various protein kinase (PKC) species, which inhibit both insulin-stimulated IRS-1 tyrosine phosphorylation and AKT2 phosphorylation (Itani et al. 2002; Samuel et al. 2010; Samuel and Shulman 2012; Szendroedi et al.



**Fig. 7** (continued) glycolysis. The net result is inhibition of insulin-mediated glucose uptake (insulin resistance). B. AMP kinase (AMPK) hypothesis. According to this hypothesis, AMPK is a key regulator of glucose and fatty acid oxidation. For example, exercise promotes the activity of AMPK, which increases glucose uptake through GLUT4. Increased activity of AMPK likewise promotes mitochondrial uptake of LCFA CoA and oxidation by increasing carnitine palmitoyltransferase-1 (CPT1). This latter effect is mediated through phosphorylation of acetyl-CoA carboxylase (ACC), which reduces malonyl CoA, an inhibitor of CPT1. Through these mechanisms, a reduction in physical activity could enhance insulin resistance. C. Inhibition of insulin signaling cascade by fatty acids. According to this hypothesis, the uptake of excess fatty acids by the muscle leads to overproduction of DAG and ceramide. Both products apparently stimulate certain protein kinase Cs that inhibit threonine phosphorylation of IRS, which blocks the insulin signaling cascade and causes insulin resistance. D. Inhibition of insulin signaling by excess cytokines. Accordingly, the uptake of excess cytokines activates c-Jun N-terminal kinases (JNKs) and inhibitor of nuclear factor kappa-B kinase subunit beta (IKKB), which inhibit threonine phosphorylation of IRS and block the insulin signaling cascade

2014). By interfering with insulin signaling cascade, the transfer of glucose transporters (GLUT4) to the cell surface is reduced, and glucose uptake is impaired. This mechanism seems more consistent with available data to explain the occurrence of insulin resistance following overload to the muscle with fatty acids.

Closely allied to the latter pathways for insulin resistance is the inflammatory hypothesis (Fig. 7c) (Hotamisligil et al. 1993; Lee and Ozcan 2014; Weisberg et al. 2003). An increase in circulating inflammatory cytokines stimulates intermediates in signaling pathways (c-Jun N-terminal kinase [JNK] and IKappa B kinase beta [IKK beta]), which inhibit tyrosine phosphorylation of IRS-1 and IRS-2, leading to defective insulin signaling and causing insulin resistance (Bandyopadhyay et al. 2005; Osborn and Olefsky 2012). Some of the cytokines that trigger inhibition of insulin signaling in the muscle may be derived from macrophage invasion in adipose tissue embedded within muscle tissue (Fink et al. 2013, 2014). Beyond this, cytokines released from macrophages in usual adipose tissue beds could contribute to insulin resistance in the muscle.

Other factors have been postulated to induce or to protect against insulin resistance. Among these are the so-called adipokines, which are derived from adipose tissues. Examples include adiponectin and resistin. Increased adiponectin expression is associated with reduced insulin resistance, whereas increased resistin may induce insulin resistance. The mechanisms whereby these adipokines affect muscle metabolism remain to be determined. Postulated actions of adiponectin include activation of AMPK (Kubota et al. 2007) or reduced formation of ceramides (Holland et al. 2011).

Physical activity is accompanied by a reduction of insulin resistance (Pers-eghin et al. 1996). The pathways stimulated by physical activity likely are multiple. One hypothesis holds that exercise activates AMP kinase, which in turn has a myriad of actions (Richter and Ruderman 2009). This action could account for the increased fatty acid oxidation and for enhanced biogenesis of mitochondria accompanying exercise.

As already noted, overnutrition increases lean body mass (Forbes 1993). This results in a greater capacity for energy expenditure, which should buffer against the accumulation of ectopic lipid. But if overnutrition overrides a greater oxidative capacity, ectopic lipid and insulin resistance will ensue. The latter, of course, predisposes to hyperglycemia, which is a component of the metabolic syndrome.

## Liver

About one-third of ingested glucose enters the liver directly via non-insulin-dependent uptake (Cushman 2002). Hepatic pathways for glucose are shown in Fig. 7. A major portion diet-derived glucose is stored as glycogen (Fig. 7). During fasting, glycogen is degraded, and glucose is released into the circulation. At the same time, gluconeogenic substrates (e.g., lactate, alanine, and glycerol) can be converted to glucose, which is released into the circulation. Insulin inhibits gluconeogenesis by activating forkhead box protein O1 (FOXO1) (Puigserver et al. 2003). In type

2 diabetes, when the liver is insulin resistant, FOXO1 is downregulated. This allows for increased gluconeogenesis and greater hepatic glucose output. Conversely, in spite of insulin resistance, hyperinsulinemia still activates the sterol regulatory element-binding protein 1c (SREBP-1c); this pathway drives greater synthesis of fatty acids (Brown and Goldstein 2008). In addition, with hyperglycemia, when there is increased flux through the pentose phosphate pathway, carbohydrate-responsive element-binding protein (ChREBP) is activated. Activation of ChREBP likewise promotes the synthesis of fatty acids (Uyeda et al. 2002). In spite of increases in these two pathways of lipogenesis, the liver's major source of fatty acids comes from external NEFA. Normally, about two-thirds of hepatic fatty acids are oxidized; the remainder are re-esterified into triglyceride, which, along with apolipoprotein B, are incorporated into VLDL and are secreted into the circulation.

A high caloric intake raises the liver's nutrient load. This load in part consists of NEFA that originate in adipose tissue. Other sources of fatty acids are those released by lipolysis of TGRLP in the splanchnic circulation (Donnelly et al. 2005) and by direct uptake of triglyceride in chylomicron remnants. In the presence of insulin resistance, more glucose is diverted from the muscle to liver; this stimulates hepatic lipogenesis (Flannery et al. 2012). Ultimately, all of these sources of lipid are raised by overnutrition.

The accumulation of ectopic triglyceride in the liver, when excessive, constitutes nonalcoholic fatty liver disease (NAFLD). In some individuals, NAFLD progresses to nonalcoholic steatohepatitis (NASH), and NASH in turn is a risk factor for cirrhosis and/or liver cancer. NAFLD rarely occurs in the absence of obesity (Vega et al. 2007), which is indicative of overnutrition. Of importance, the majority of obese individuals do not develop NAFLD (Vega et al. 2007). Thus, a high input of fatty acids into the liver per se is not sufficient to cause NAFLD. Those who develop fatty liver seemingly have metabolic defects that entrap excess triglyceride in the liver (Romeo et al. 2008).

The major consequence of increased input of fatty acids into the liver is overproduction of VLDL particles (Grundy et al. 1979). These lipoproteins contain both triglyceride and apolipoprotein B (apo B). In many people, but not all, overproduction of VLDL raises plasma levels of both triglyceride and apo B (Kesäniemi et al. 1985; Egusa et al. 1985). Those who are able to avoid elevations of VLDL have a robust hydrolysis of VLDL triglyceride. Those in whom plasma levels of VLDL are elevated carry increased risk for atherosclerotic disease (Assmann and Schulte 1992; Kastelein et al. 2008; Toth 2016). This is because atherogenicity of VLDL particles is similar to that of LDL (Kastelein et al. 2008; Toth 2016). Increased nutrient overload on the liver also stimulates the synthesis of hepatic lipase (Nie et al. 1998); this enzyme partially degrades HDL and lowers HDL-cholesterol levels.

As noted, overnutrition raises the liver's load of glucose. However, the regulation of glucose uptake by the liver is complex and affected by multiple factors (Cherrington 1999). In type 2 diabetes, hepatic glucose output appears to be increased. Overnutrition primes the liver for increased hepatic glucose output by maintaining glycogen stores. Normally, insulin inhibits hepatic glucose output by several mechanisms: inhibition of glucagon secretion, reduction in plasma NEFA,

and reduction of gluconeogenic precursors. It has been reported that in insulin-resistant states, e.g., type 2 diabetes, the liver is resistant to the actions of insulin to suppress gluconeogenesis but remains sensitive to the actions of insulin to stimulate hepatic lipogenesis (Shimomura et al. 2000).

## **Kidney**

Elevated blood pressure is one of the risk factors of the metabolic syndrome. Hyperinsulinemia may be one direct cause of hypertension (Rao et al. 2015). Another potential cause is the presence of ectopic lipid in the renal sinus and perinephric space (Foster et al. 2011). Excess fat in the renal sinus may compress kidney venules and lymphatics and thus impair the regulation of blood pressure. In addition, accumulation of large amounts of fat in the perinephric may compress the kidneys, induce ischemia, and cause hypertension (Hall 2000).

## **Heart**

Persons with metabolic syndrome have been reported to have increased epicardial fat. Several investigators (Lee et al. 2016; Iacobellis 2015; Homsí et al. 2016; Wu et al. 2016) postulate that this ectopic fat is detrimental. Possible abnormalities engendered by cardiac ectopic fat include excess local release of fatty acids, inflammation, endothelial dysfunction, abnormal microcirculation, and increased atherogenesis.

---

## **Adverse Effects of Carbohydrate Overnutrition**

Carbohydrate is the major source of energy in the diet. The average 70-kg man consumes approximately 315 g of carbohydrate. About 90% of this amount consists of glucose, a portion of which derives disaccharides or complex carbohydrate (starch). The remaining 10% comes from fructose or other non-glucose sugars. Newly absorbed glucose is distributed approximately equally to the muscle, liver, brain, and other tissues. In the postprandial state, a significant portion of glucose going to the liver and muscle is converted to glycogen, where it provides nutrient energy for the fasting state. When intake of carbohydrates is high, glucose can undergo lipogenesis, i.e., conversion to fatty acids. In nonobese individuals, rates of lipogenesis are relatively low, but in obese persons, in whom carbohydrate intake is excessive, lipogenesis occurs and can contribute to ectopic lipid (Schwarz et al. 2003; Aarsland et al. 1996; Aarsland and Wolfe 1998). Continuous consumption of excess carbohydrate contributes to hyperinsulinemia, which is characteristic of obese persons. If insulin signatory capacity falls, hyperglycemia can develop and is sustained by overnutrition. This is the metabolic phenotype of most patients with type 2 diabetes.



Fructose has received special attention as a potential cause of metabolic syndrome (Stanhope et al. 2013, 2009, 2011). It is claimed that high intakes of fructose favor hepatic de novo lipogenesis, dyslipidemia, and hyperglycemia in obese persons (Stanhope et al. 2011). This possibility is of concern because of a high intake of fructose-containing sugars in the American diet. More research is required to evaluate these intriguing claims of unique metabolic dysfunction accompanying substantial fructose ingestion (Tappy and Lê 2010).

When carbohydrate intake is excessive, de novo lipogenesis may induce ectopic lipid accumulation and its metabolic consequences (including insulin resistance). It is not generally recognized that hyperglycemia itself worsens insulin resistance (Abate et al. 1996). The mechanism for this action has not been fully elucidated (Kawanaka et al. 2001; Renström et al. 2007; Robinson and Buse 2008; Nelson et al. 2002), but it may create a vicious cycle accentuating hyperglycemia.

Persistent elevations of plasma glucose, which come mainly from excess dietary carbohydrate, contribute to development of microvascular disease, neuropathy, and possibly atherosclerosis and cardiomyopathy. The mechanisms for these complications have been extensively studied, but not fully resolved. One favored mechanism is hyperglycemia that results in increased influx of glucose into the vascular and peripheral nervous cells (Brownlee 2005). An excess of intracellular glucose may have several adverse effects (Fig. 8).

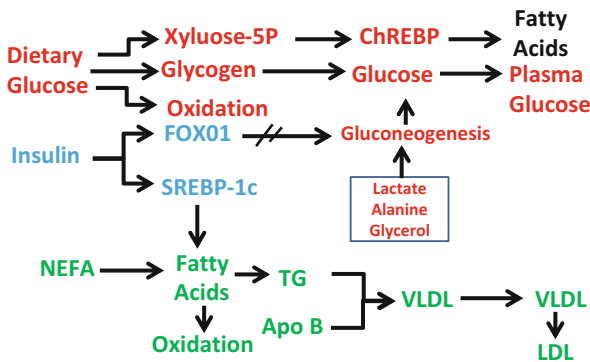

**Fig. 8** Metabolism of glucose and fatty acids in the liver. Dietary glucose is largely taken up by the liver. In the postprandial state, it is heavily converted to glycogen, which is a source of glucose in the fasting state. And hepatic glucose can also undergo glycolysis and oxidation. The uptake of excess glucose promotes the glucose shunt pathway, which activates a nuclear receptor named carbohydrate receptor element-binding protein; this protein in turn activates enzymes involved in fatty acid synthesis. Insulin has two actions of interest in the liver. It activates the transcription factor called forkhead box protein O1 (FOXO1), which inhibits gluconeogenesis. Insulin also activates the transcription factor SREBP-1C that promotes fatty acid synthesis from glucose. However, the major source of fatty acids in the liver is NEFA, derived from adipose tissue or triglyceride-rich lipoproteins. In the liver, fatty acids can be resynthesized into triglycerides and incorporated, along with apo B, into VLDL, which are secreted into plasma. Alternatively, hepatic fatty acids can either be oxidized completely or are broken down into ketone bodies

First, excess glucose in cells may lead to greater glucose flux through the sorbitol-aldose reductase (polyol) pathway (Gabbay et al. 1966). This pathway depletes nicotinamide adenine denucleotide phosphate hydrogen (NADPH), which is needed for other metabolic pathways. Accumulation of sorbitol may further enhance oxidative stress and cause tissue damage.

Second, a potential mechanism for angiopathy and neuropathy is the formation of bioactive molecules resembling methylglyoxal; these molecules engender *advanced glycation end products* (AGEs) (Brownlee et al. 1984; Li et al. 1996; Giardino et al. 1994). AGE precursors further modify intracellular proteins, especially those involved in gene transcription (Giardino et al. 1994; Shinohara et al. 1998). They also can leak out of cells and modify the extracellular matrix (McLellan et al. 1994); this effect disturbs signaling between the matrix and the cell (Charonis et al. 1990). Finally, extracellular AGEs can modify circulating serum proteins. Some of these proteins bind to and activate AGE receptors, which drive the production of inflammatory cytokines and growth factors (Neeper et al. 1992; Smedsrød et al. 1997; Vlassara et al. 1995).

Third, another potentially pathogenic pathway is glucose activation of protein kinase C (PKC), which includes a family of enzymes influencing the actions of many other proteins; examples include PKC- $\alpha$ , PKC- $\beta$ 1/2, and PKC- $\delta$  (Geraldes and King 2010). Activation of these pathways has been implicated in development of micro- and macrovascular disease and neuropathies. These pathologies may be secondary to multiple cellular changes, i.e., permeability, contractility, extracellular matrix synthesis, cell growth and apoptosis, angiogenesis, leukocyte adhesion, and activation and inhibition of cytokines (Geraldes and King 2010).

And fourth, during glycolysis, fructose-6-phosphate can pass into a signaling pathway in which UDP (uridine diphosphate) N-acetyl glucosamine is formed (Brownlee 2005; Buse 2006). This hexosamine pathway forms transcription factors that may adversely affect downstream metabolism.

**Fig. 9** Pathways of glucotoxicity contributing to microvascular disease and neuropathy. Hyperglycemia causes increased glucose uptake into vascular cells and nerve cells. This excess glucose can have several fates that may be pathogenic. These pathways are described in the text

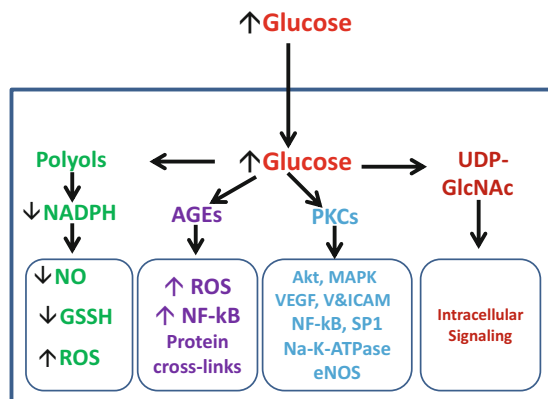

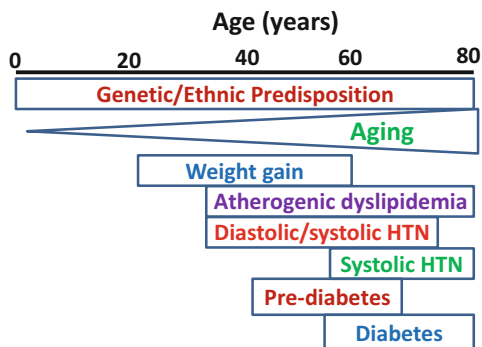

**Fig. 10** Timeline for the development of metabolic syndrome. Some individuals are genetically prone to metabolic syndrome based on individual ethnic characteristics; these important metabolic defects persisting throughout life still may be latent until other factors uncover their contribution to metabolic syndrome. Among these gradual but progressive metabolic derangements that occur with aging are weight gain that is common in middle age. Atherogenic dyslipidemia and diastolic/systolic hypertension typically appear in early middle age. Systolic hypertension may worsen with advancing age. Prediabetes usually manifests at least a decade before the onset of categorical diabetes

## Timeline for Development of the Metabolic Syndrome

Metabolic risk factors make their appearance at different times over an individual's lifetime (Fig. 9). Most persons who manifest the metabolic syndrome are either genetically or ethnically predisposed. Risk factors typically develop or worsen with advancing age. In the first half of life, even susceptible people usually are able to compensate for a high energy intake without manifesting risk factors. At some age, however, it is not possible to balance caloric intake with energy expenditure; at this time, excess adipose tissue begins to accumulate. With weight gain comes greater likelihood of metabolic risk factors. An early manifestation of obesity is hyperinsulinemia and insulin resistance. These abnormalities predispose to prediabetes and later to categorical diabetes. Atherogenic dyslipidemia most commonly appears in middle age. For most people, blood pressure begins to rise in the second half of life; first to appear is obesity-associated hypertension; this is made worse by age-associated arterial stiffening. Finally, pro-inflammatory and prothrombotic states occur in parallel with obesity and persist throughout life. Thus, metabolic syndrome typically appears first in middle age but worsens with advancing age (Fig. 10).

## Obesity Without Metabolic Syndrome

The majority of obese people do not have metabolic syndrome (Grundy et al. 2014). These people presumably have metabolic defenses against risk factor development. Certain body characteristics are commonly present. For a given degree of obesity,

young adults are less likely to manifest the metabolic syndrome than older persons. Those with predominant lower body obesity are less susceptible than those with upper body obesity (Jensen 2008; Pinnick et al. 2014). Hyperplastic obesity may be more protective than hypertrophic obesity (Klötting and Blüher 2014; Gustafson et al. 2013). For the same body fat content, men appear to be more susceptible than women. Ethnic/genetic factors can affect susceptibility. The risk for metabolic syndrome increases with age (Barzilai et al. 2012). A large body of evidence indicates that the regulation of blood pressure, plasma lipids, and glucose levels varies substantially among individuals. Finally, the number of metabolic risk factors varies in obese persons. Some individuals may have an insufficient number of risk factors to qualify for a clinical diagnosis of metabolic syndrome, but they may still suffer the consequences of individual risk factors (e.g., hypertension, dyslipidemia, or hyperglycemia).

---

## Metabolic Syndrome Without Obesity

Some persons have multiple metabolic risk factors without obesity (Ruderman et al. 1981, 1998). Many of these, but not all, fall in the overweight category (Grundy et al. 2014). In general, nonobese individuals with metabolic syndrome have susceptibility factors, particularly genetic/ethnic characteristics. South Asians (Abate et al. 2004) and Hispanic (Grundy et al. 2014) are especially susceptible to metabolic syndrome. First-degree relatives of patients with type 2 diabetes are also prone to insulin resistance and metabolic risk factors (Janghorbani and Amini 2011; Meis et al. 2006). Those who manifest the syndrome in the absence of obesity provide a good example of how susceptibility factors play an important role in the development of the condition.

---

## Lifestyle Intervention on Metabolic Syndrome

First-line intervention for metabolic syndrome is to modify lifestyle (National Cholesterol Education Program ATP III 2002; Alberti et al. 2009). Interventions include caloric restriction, increased physical activity, and modification of diet composition.

Just how much caloric restriction is needed to eliminate metabolic risk factors depends on the degree of susceptibility to overnutrition. Clinical trials demonstrate that an approximate 10% reduction in body weight typically will substantially reduce metabolic risk factors (Goldberg and Mather 2012). And if a patient is motivated, behavioral modification can generally reduce body weight by this amount (Knowler et al. 2002). Although such a weight loss may not completely eliminate metabolic risk factors, the overall effect can be considerable. Thus, caloric restriction represents the first modality in management of the metabolic syndrome.

A greater reduction in body weight can be achieved with bariatric surgery. Body weight generally is reduced by about 20%. In patients with metabolic syndrome, risk factors of metabolic origin usually are normalized (Buchwald et al. 2004; Clifton 2011). A critical question is whether a similar benefit can be achieved with

pharmacological therapy directed against individual risk factors. Comparison studies have not been carried out. The ability of bariatric surgery to eliminate metabolic risk factors emphasizes the primary importance of overnutrition as a cause of the syndrome.

---

## Management of Individual Metabolic Risk Factors

### Atherogenic Dyslipidemia

The primary target of treatment of atherogenic dyslipidemia is to reduce plasma levels of apo B-containing lipoproteins (both LDL and VLDL). In the clinical setting, these lipoproteins can be measured as non-HDL-C (Kastelein et al. 2008; Grundy et al. 2009). To maximize risk reduction, non-HDL-C should be reduced as much as feasible (Jarcho and Keaney 2015). For patients with established ASCVD, reducing non-HDL-C to <100 mg/dL is reasonable; for those without ASCVD, it is reasonable to lower non-HDL-C to <130 mg/dL (Jacobson et al. 2015). These two targets equate to low-density lipoprotein cholesterol (LDL-C) levels of <70 mg/dL and <100 mg/dL, respectively. Clinical trial evidence supports these goals in patients with metabolic syndrome (Pyörälä et al. 2004; Deedwania et al. 2006; Matsushima et al. 2012).

For lipid-lowering drug therapy, statins are first-line agents. The dose of statin therapy should be adjusted to achieve the goal of treatment. For patients with established ASCVD, a non-HDL-C to <100 mg/dL can usually be attained with high-intensity statins (atorvastatin 80 mg or rosuvastatin 20–40 mg). This corresponds to an LDL-C level of approximately <70 mg/dL. Addition of ezetimibe to statin therapy will give additional risk reduction (Cannon et al. 2015). For primary prevention, high-intensity statins can be used if well tolerated. If not, it is possible to combine a moderate-intensity statin (atorvastatin 10 mg, rosuvastatin 5 mg, or simvastatin 10–20 mg) with ezetimibe 10 mg. In patients with ASCVD who are at very high risk, consideration can be treated with monogenic antibodies against the plasma protein PCSK9. This protein promotes degradation of LDL receptors and raises LDL-C levels. Removal of PCSK9 with monogenic antibodies (PCSK9 inhibitors) markedly reduces LDL-C. The Food and Drug Administration (FDA) has approved PCSK9 inhibitors for very high-risk patients. Preliminary evidence suggests that they substantially reduce risk for future ASCVD events (Robinson et al. 2015; Sabatine et al. 2015). Unfortunately, these inhibitors are expensive and thus currently must be reserved for patients at highest risk.

Since many patients with metabolic syndrome have elevated triglycerides, a persistent question has been whether to add a triglyceride-lowering drug to statin therapy. Such agents are niacin and fibrates. Clinical trials in which these drugs have been added to statins have not been encouraging. Consequently, the FDA recommends against such combinations. Instead, in patients with moderate hypertriglyceridemia, high-intensity statins should be sufficient. In rare patients with

severe hypertriglyceridemia, fibrates may be necessary to lower triglycerides so as to prevent acute pancreatitis. A triglyceride level of  $>500$  mg/dL is generally regarded as a reasonable threshold for starting a fibrate. In these patients, combining a low-intensity statin with a fibrate may be appropriate.

Although a reduced level of HDL-C is a risk predictor in patients with metabolic syndrome, there is little clinical trial evidence that raising HDL-C levels will reduce the risk for future ASCVD events. This remains an area of investigation, but for now, drugs that specifically raise HDL-C cannot be recommended for patients with metabolic syndrome (Miller 2014).

## Hypertension

A reasonable blood pressure goal for patients with metabolic syndrome is a level  $<140/80$  mmHg (James et al. 2014). Reducing systolic blood pressure to  $<120$  mmHg may provide an additional reduction in cardiovascular risk (SPRINT Research Group et al. 2015). Caloric restriction will decrease blood pressure in patients with metabolic syndrome (Reisin et al. 1978; Tuck et al. 1981). This is especially true for patients undergoing bariatric surgery (Flores et al. 2014; Ricci et al. 2014; Wilhelm et al. 2014). Reducing saturated fat and sodium and increasing potassium in the diet facilitate blood pressure lowering (Hikmat and Appel 2014). Some investigators contend that ACE inhibitors or angiotensin receptor blockers are the preferred blood pressure lowering drugs in patients with metabolic syndrome (Zreikat et al. 2014; Kamide 2014). Calcium channel blockers can be used without concern for unique side effects in metabolic syndrome (Lithell 1996; Farah et al. 2013). Beta-1 receptor blockers (e.g., atenolol and metoprolol) and thiazide diuretics potentially worsen metabolic risk factors (Standl et al. 2012; Dronavalli and Bakris 2008). This fact however does not preclude their use when they are considered necessary.

## Hyperglycemia

Individuals with metabolic syndrome can have normoglycemia, borderline diabetes (prediabetes), or categorical hyperglycemia (diabetes). In those at high risk for diabetes, a progressive increase in glucose levels can be delayed by caloric restriction combined with moderate physical activity (American Diabetes Association 2014; Knowler et al. 2009). Metformin also can delay conversion of prediabetes to diabetes but less effectively than lifestyle intervention (Knowler et al. 2009). For patients who have clinical diabetes, hypoglycemic drugs usually are necessary to reduce hemoglobin A1c levels to a reasonable goal of  $<7\%$ . The American Diabetes Association and European Association for the Study of Diabetes offer well-considered recommendations for the treatment of hyperglycemia in type 2 diabetes (Inzucchi et al. 2015).

## Pro-inflammatory State

A variety of inflammatory markers have been identified that associate with increased risk for cardiovascular disease: interleukin-1- $\beta$ , interleukin-18, interleukin-6, tumor necrosis factor- $\alpha$ , matrix metalloproteinase-9, lipoprotein-associated phospholipase A2, secretory phospholipase A2, intercellular adhesion molecule type 1, vascular cellular adhesion molecule, plasminogen activator inhibitor type 1, serum amyloid A, C-reactive protein, 5-lipoxygenase, sirtuin-1, and chemokine receptor types 2 and 5 (Ridker and Lüscher 2014). Many of these are elevated in patients with metabolic syndrome; in such patients, caloric restriction will reduce many inflammatory markers. Currently a variety of drugs are under study to determine their efficacy for reducing the pro-inflammatory state and cardiovascular disease (Everett et al. 2013; Ridker et al. 2011; Tardif et al. 2010). At present, none of these are ready for clinical usage.

## Prothrombotic State

Prothrombotic factors can be reduced by caloric restriction (Bladbjerg et al. 2014). For metabolic syndrome patients who have ASCVD, aspirin therapy is indicated. Aspirin is also reasonable for primary prevention in those at higher risk (US Preventive Services Task Force 2009; Pignone et al. 2010; Goldstein et al. 2011). Other anticoagulants or antiplatelet drugs are not indicated for routine use in patients with metabolic syndrome.

---

## References

- Aarsland A, Chinkes D, Wolfe RR. Contributions of de novo synthesis of fatty acids to total VLDL-triglyceride secretion during prolonged hyperglycemia/hyperinsulinemia in normal man. *J Clin Invest.* 1996;98(9):2008–17.
- Aarsland A, Wolfe RR. Hepatic secretion of VLDL fatty acids during stimulated lipogenesis in men. *J Lipid Res.* 1998;39(6):1280–6.
- Abate N, Burns D, Peshock RM, Garg A, Grundy SM. Estimation of adipose tissue mass by magnetic resonance imaging: validation against dissection in human cadavers. *J Lipid Res.* 1994;35(8):1490–6.
- Abate N, Chandalia M, Snell PG, Grundy SM. Adipose tissue metabolites and insulin resistance in nondiabetic Asian Indian men. *J Clin Endocrinol Metab.* 2004;89(6):2750–5.
- Abate N, Garg A, Peshock RM, Stray-Gundersen J, Adams-Huet B, Grundy SM. Relationship of generalized and regional adiposity to insulin sensitivity in men with NIDDM. *Diabetes.* 1996;45(12):1684–93.
- Abate N, Garg A, Peshock RM, Stray-Gundersen J, Grundy SM. Relationships of generalized and regional adiposity to insulin sensitivity in men. *J Clin Invest.* 1995;96(1):88–98.
- Alberti KG, Eckel RH, Grundy SM, Zimmet PZ, Cleeman JI, Donato KA, International Diabetes Federation Task Force on Epidemiology and Prevention, National Heart, Lung, and Blood Institute, American Heart Association, World Heart Federation, International Atherosclerosis Society, International Association for the Study of Obesity, et al. Harmonizing the metabolic

- syndrome: a joint interim statement of the international diabetes federation task force on epidemiology and prevention; National Heart, Lung, and Blood Institute; American Heart Association; world heart federation; international atherosclerosis society; and International Association for the Study of obesity. *Circulation*. 2009;120(16):1640–5.
- Albu JB, Kovera AJ, Allen L, Wainwright M, Berk E, Raja-Khan N, et al. Independent association of insulin resistance with larger amounts of intermuscular adipose tissue and a greater acute insulin response to glucose in African American than in white nondiabetic women. *Am J Clin Nutr*. 2005;82:1210–7.
- Almadoz JP, Singh E, Howell LA, Grothe K, Vlazny DT, Smailovic A, et al. Spillover of fatty acids during dietary fat storage in type 2 diabetes: relationship to body fat depots and effects of weight loss. *Diabetes*. 2013;62(6):1897–903.
- Almind K, Bjorbaek C, Vestergaard H, Hansen T, Echwald S, Pedersen O. Amino acid polymorphisms of insulin receptor substrate-1 in non-insulin-dependent diabetes mellitus. *Lancet*. 1993;342:828–32.
- American Diabetes Association. Standards of medical care in diabetes–2014. *Diabetes Care*. 2014;37(Suppl 1):S14–80.
- Assmann G, Schulte H. The importance of triglycerides: results from the prospective cardiovascular Münster (PROCAM) study. *Eur J Epidemiol*. 1992;8(Suppl 1):99–103.
- Bandyopadhyay GK, Yu JG, Ofrecio J, Olefsky JM. Increased p85/55/50 expression and decreased phosphatidylinositol 3-kinase activity in insulin-resistant human skeletal muscle. *Diabetes*. 2005;54:2351–9.
- Barden A, Singh R, Walters B, Phillips M, Beilin LJ. A simple scoring method using cardiometabolic risk measurements in pregnancy to determine 10-year risk of type 2 diabetes in women with gestational diabetes. *Nutr Diabetes*. 2013;3:e72.
- Barzilai N, Huffman DM, Muzumdar RH, Bartke A. The critical role of metabolic pathways in aging. *Diabetes*. 2012;61(6):1315–22.
- Bävenholm PN, Kuhl J, Pigon J, Saha AK, Ruderman NB, Efendic S. Insulin resistance in type 2 diabetes: association with truncal obesity, impaired fitness, and atypical malonyl coenzyme a regulation. *J Clin Endocrinol Metab*. 2003;88(1):82–7.
- Berg AH, Scherer PE. Adipose tissue, inflammation, and cardiovascular disease. *Circ Res*. 2005;96(9):939–49.
- Bishop DJ, Granata C, Eynon N. Can we optimise the exercise training prescription to maximise improvements in mitochondria function and content? *Biochim Biophys Acta*. 2014;1840(4):1266–75.
- Björntorp P. “portal” adipose tissue as a generator of risk factors for cardiovascular disease and diabetes. *Arteriosclerosis*. 1990;10(4):493–6.
- Björntorp P. Metabolic implications of body fat distribution. *Diabetes Care*. 1991;14:1132–43.
- Björntorp P. The regulation of adipose tissue distribution in humans. *Int J Obes Relat Metab Disord*. 1996;20(4):291–302.
- Björntorp P. Visceral obesity: a “civilization syndrome”. *Obes Res*. 1993;1:206–22.
- Bladbjerg EM, Larsen TM, Due A, Jespersen J, Stender S, Astrup A. Postprandial coagulation activation in over-weight individuals after weight loss: acute and long-term effects of a high-monounsaturated fat diet and a low-fat diet. *Thromb Res*. 2014;133:327–33.
- Boden G, Chen X, Iqbal N. Acute lowering of plasma fatty acids lowers basal insulin secretion in diabetic and nondiabetic subjects. *Diabetes*. 1998;47:1609–12.
- Boden G, Chen X, Rosner J, Barton M. Effects of a 48-h fat infusion on insulin secretion and glucose utilization. *Diabetes*. 1995;44(10):1239–42.
- Boden G. Obesity, insulin resistance and free fatty acids. *Curr Opin Endocrinol Diabetes Obes*. 2011;18(2):139–43.
- Brown MS, Goldstein JL. Selective versus total insulin resistance: a pathogenic paradox. *Cell Metab*. 2008;7(2):95–6.
- Brownlee M, Vlassara H, Cerami A. Nonenzymatic glycosylation and the pathogenesis of diabetic complications. *Ann Intern Med*. 1984;101(4):527–37.
- Brownlee M. The pathobiology of diabetic complications: a unifying mechanism. *Diabetes*. 2005;54(6):1615–25.



- Buchwald H, Avidor Y, Braunwald E, Jensen MD, Pories W, Fahrbach K, et al. Bariatric surgery: a systematic review and metaanalysis. *JAMA*. 2004;292:1724–37.
- Buse MG. Hexosamines, insulin resistance, and the complications of diabetes: current status. *Am J Physiol Endocrinol Metab*. 2006;290(1):E1–8.
- Cannon CP, Blazing MA, Giugliano RP, McCagg A, White JA, Theroux P, et al. Ezetimibe added to statin therapy after acute coronary syndromes. *N Engl J Med*. 2015;372:2387–97.
- Carlsson AC, Risérus U, Årnlöv J. Hypertriglyceridemic waist phenotype is associated with decreased insulin sensitivity and incident diabetes in elderly men. *Obesity (Silver Spring)*. 2014;22(2):526–9.
- Cefalu WT, Wang ZQ, Weibel S, Bell-Farrow A, Crouse JR 3rd, Hinson WH, et al. Contribution of visceral fat mass to the insulin resistance of aging. *Metabolism*. 1995;44(7):954–9.
- Charonis AS, Reger LA, Dege JE, Kouzi-Koliakos K, Furcht LT, Wohlhueter RM, et al. Laminin alterations after in vitro nonenzymatic glycosylation. *Diabetes*. 1990;39(7):807–14.
- Chandalia M, Lin P, Seenivasan T, Livingston EH, Snell PG, Grundy SM, et al. Insulin resistance and body fat distribution in south Asian men compared to Caucasian men. *PLoS One*. 2007;2(8):e812.
- Cherrington AD. Banting lecture 1997. Control of glucose uptake and release by the liver in vivo. *Diabetes*. 1999;48(5):1198–214.
- Clifton PM. Bariatric surgery: results in obesity and effects on metabolic parameters. *Curr Opin Lipidol*. 2011;22:1–5.
- Cushman SW. Cell biology of glucose transport: a key to understanding peripheral glucose utilization. Banting Lecture, Program and abstracts of the 62nd Scientific Sessions of the American Diabetes Association; June 14–18, 2002; San Francisco, California. *Diabetes*, 51(2).
- Decaudain A, Vantyghem MC, Guerci B, Hecart AC, Auclair M, Reznik Y, et al. New metabolic phenotypes in laminopathies: LMNA mutations in patients with severe metabolic syndrome. *J Clin Endocrinol Metab*. 2007;92:4835–44.
- Deedwania P, Barter P, Carmena R, Fruchart JC, Grundy SM, Haffner S, et al. Reduction of low-density lipoprotein cholesterol in patients with coronary heart disease and metabolic syndrome: analysis of the treating to new targets study. *Lancet*. 2006;368:919–28.
- DeFronzo RA, Tripathy D. Skeletal muscle insulin resistance is the primary defect in type 2 diabetes. *Diabetes Care*. 2009;32(Suppl 2):S157–63.
- Després JP, Lemieux I, Bergeron J, Pibarot P, Mathieu P, Larose E, et al. Abdominal obesity and the metabolic syndrome: contribution to global cardiometabolic risk. *Arterioscler Thromb Vasc Biol*. 2008;28(6):1039–49.
- Devlin CM, Leventhal AR, Kuriakose G, Schuchman EH, Williams KJ, Tabas I. Acid sphingomyelinase promotes lipoprotein retention within early atheromata and accelerates lesion progression. *Arterioscler Thromb Vasc Biol*. 2008;28(10):1723–30.
- Devries MC, Samjoo IA, Hamadeh MJ, McCreedy C, Raha S, Watt MJ, et al. Endurance training modulates intramyocellular lipid compartmentalization and morphology in skeletal muscle of lean and obese women. *J Clin Endocrinol Metab*. 2013;98(12):4852–62.
- Dobbins RL, Chester MW, Daniels MB, McGarry JD, Stein DT. Circulating fatty acids are essential for efficient glucose-stimulated insulin secretion after prolonged fasting in humans. *Diabetes*. 1998a;47(10):1613–8.
- Dobbins RL, Chester MW, Stevenson BE, Daniels MB, Stein DT, McGarry JD. A fatty acid-dependent step is critically important for both glucose- and non-glucose-stimulated insulin secretion. *J Clin Invest*. 1998b;101(11):2370–6.
- Donnelly KL, Smith CI, Schwarzenberg SJ, Jessurun J, Boldt MD, Parks EJ. Sources of fatty acids stored in liver and secreted via lipoproteins in patients with nonalcoholic fatty liver disease. *J Clin Invest*. 2005;115(5):1343–51.
- Dronavalli S, Bakris GL. Mechanistic insights into diuretic-induced insulin resistance. *Hypertension*. 2008;52:1009–11.
- Egusa G, Beltz WF, Grundy SM, Howard BV. Influence of obesity on the metabolism of apolipoprotein B in humans. *J Clin Invest*. 1985;76(2):596–603.
- El Mkaadem SA, Lautier C, Macari F, Molinari N, Lefèbvre P, Renard E, et al. Role of allelic variants Gly972Arg of IRS-1 and Gly1057Asp of IRS-2 in moderate-to-severe insulin resistance of women with polycystic ovary syndrome. *Diabetes*. 2001;50(9):2164–8.

- Esposito DL, Li Y, Vanni C, Mammarella S, Veschi S, Della Loggia F, et al. A novel T608R missense mutation in insulin receptor substrate-1 identified in a subject with type 2 diabetes impairs metabolic insulin signaling. *J Clin Endocrinol Metab.* 2003;88(4):1468–75.
- Everett BM, Pradhan AD, Solomon DH, Paynter N, Macfadyen J, Zaharris E, et al. Rationale and design of the cardiovascular inflammation reduction trial: a test of the inflammatory hypothesis of atherothrombosis. *Am Heart J.* 2013;166:199–207.e15.
- Fall T, Ingelsson E. Genome-wide association studies of obesity and metabolic syndrome. *Mol Cell Endocrinol.* 2014;382:740–57.
- Farah R, Khamisy-Farah R, Shurtz-Swirski R. Calcium channel blocker effect on insulin resistance and inflammatory markers in essential hypertension patients. *Int Angiol.* 2013;32:85–93.
- Felton CV, Crook D, Davies MJ, Oliver MF. Relation of plaque lipid composition and morphology to the stability of human aortic plaques. *Arterioscler Thromb Vasc Biol.* 1997;17(7):1337–45.
- Fink LN, Costford SR, Lee YS, Jensen TE, Bilan PJ, Oberbach A, et al. Pro-inflammatory macrophages increase in skeletal muscle of high fat-fed mice and correlate with metabolic risk markers in humans. *Obesity (Silver Spring).* 2014;22:747–57.
- Fink LN, Oberbach A, Costford SR, Chan KL, Sams A, Bluher M, et al. Expression of anti-inflammatory macrophage genes within skeletal muscle correlates with insulin sensitivity in human obesity and type 2 diabetes. *Diabetologia.* 2013;56:1623–8.
- Flannery C, Dufour S, Rabøl R, Shulman GI, Petersen KF. Skeletal muscle insulin resistance promotes increased hepatic de novo lipogenesis, hyperlipidemia, and hepatic steatosis in the elderly. *Diabetes.* 2012;61(11):2711–7.
- Flores L, Vidal J, Canivell S, Delgado S, Lacy A, Esmatjes E. Hypertension remission 1 year after bariatric surgery: predictive factors. *Surg Obes Relat Dis.* 2014;10:661–5.
- Forbes GB. The companionship of lean and fat. In: Ellis KJ, Eastman JD, editors. *Human body composition.* New York: Plenum Press; 1993. p. 3–14.
- Foster MC, Hwang SJ, Porter SA, Massaro JM, Hoffman U, Fox CS. Fatty kidney, hypertension, and chronic kidney disease: the Framingham heart study. *Hypertension.* 2011;58(5):784–90.
- Fried SK, Kral JG. Sex differences in regional distribution of fat cell size and lipoprotein lipase activity in morbidly obese patients. *Int J Obes.* 1987;11:129–40.
- Fryer LG, Fougelle F, Barnes K, Baldwin SA, Woods A, Carling D. Characterization of the role of the AMP-activated protein kinase in the stimulation of glucose transport in skeletal muscle cells. *Biochem J.* 2002;363:167–74.
- Gabbay KH, Merola LO, Field RA. Sorbitol pathway: presence in nerve and cord with substrate accumulation in diabetes. *Science.* 1966;151(3707):209–10.
- Gami AS, Witt BJ, Howard DE, Erwin PJ, Gami LA, Somers VK, et al. Metabolic syndrome and risk of incident cardiovascular events and death: a systematic review and meta-analysis of longitudinal studies. *J Am Coll Cardiol.* 2007;49(4):403–14.
- Garg A, Misra A. Lipodystrophies: rare disorders causing metabolic syndrome. *Endocrinol Metab Clin N Am.* 2004;33(2):305–31.
- Garg A. Acquired and inherited lipodystrophies. *N Engl J Med.* 2004;350(12):1220–34.
- Gehrisch S. Common mutations of the lipoprotein lipase gene and their clinical significance. *Curr Atheroscler Rep.* 1999;1(1):70–8.
- Geraldes P, King GL. Activation of protein kinase C isoforms and its impact on diabetic complications. *Circ Res.* 2010;106(8):1319–31.
- Giardino I, Edelstein D, Brownlee M. Nonenzymatic glycosylation in vitro and in bovine endothelial cells alters basic fibroblast growth factor activity. A model for intracellular glycosylation in diabetes. *J Clin Invest.* 1994;94(1):110–7.
- Goldberg RB, Mather K. Targeting the consequences of the metabolic syndrome in the diabetes prevention program. *Arterioscler Thromb Vasc Biol.* 2012;32:2077–90.
- Goldstein LB, Bushnell CD, Adams RJ, Appel LJ, Braun LT, Chaturvedi S, et al. Guidelines for the primary prevention of stroke: a guideline for health care professionals from the American Heart Association/ American Stroke Association. *Stroke.* 2011;42:517–84.

- Goodpaster BH, He J, Watkins S, Kelley DE. Skeletal muscle lipid content and insulin resistance: evidence for a paradox in endurance-trained athletes. *J Clin Endocrinol Metab.* 2001;86(12):5755–61.
- Grundy SM, Cleeman JI, Daniels SR, Donato KA, Eckel RH, Franklin BA, et al. American Heart Association; National Heart, Lung, and Blood Institute. Diagnosis and management of the metabolic syndrome: an American Heart Association/National Heart, Lung, and Blood Institute scientific statement. *Circulation.* 2005;112(17):2735–52.
- Grundy SM, Mok HY, Zech L, Steinberg D, Berman M. Transport of very low density lipoprotein triglycerides in varying degrees of obesity and hypertriglyceridemia. *J Clin Invest.* 1979;63(6):1274–83.
- Grundy SM, Neeland IJ, Turer AT, Vega GL. Ethnic and gender susceptibility to metabolic risk. *Metab Syndr Relat Disord.* 2014;12(2):110–6.
- Grundy SM, Neeland IJ, Turer AT, Vega GL. Waist circumference as measure of abdominal fat compartments. *J Obes.* 2013;2013:454285.
- Grundy SM, Vega GL, Tomassini JE, Tereshakovec AM. Correlation of non-high-density lipoprotein cholesterol and low-density lipoprotein cholesterol with apolipoprotein B during simvastatin þ fenofibrate therapy in patients with combined hyperlipidemia (a subanalysis of the SAFARI trial). *Am J Cardiol.* 2009;104:548–53.
- Grundy SM. Adipose tissue and metabolic syndrome: too much, too little or neither. *Eur J Clin Investig.* 2015;45:1209–17.
- Grundy SM. Metabolic syndrome pandemic. *Arterioscler Thromb Vasc Biol.* 2008;28(4):629–36.
- Grundy SM. Metabolic syndrome: a multiplex cardiovascular risk factor. *J Clin Endocrinol Metab.* 2007;92(2):399–404.
- Guerrero R, Vega GL, Grundy SM, Browning JD. Ethnic differences in hepatic steatosis: an insulin resistance paradox? *Hepatology.* 2009;49(3):791–801.
- Guo ZK, Hensrud DD, Johnson CM, Jensen MD. Regional postprandial fatty acid metabolism in different obesity phenotypes. *Diabetes.* 1999;48:1586–92.
- Gustafson B, Hammarstedt A, Hedjazifar S, Smith U. Restricted adipogenesis in hypertrophic obesity: the role of WISP2, WNT, and BMP4. *Diabetes.* 2013;62(9):2997–3004.
- Hajat C, Shather Z. Prevalence of metabolic syndrome and prediction of diabetes using IDF versus ATPIII criteria in a Middle East population. *Diabetes Res Clin Pract.* 2012;98(3):481–6.
- Hall JE. Pathophysiology of obesity hypertension. *Curr Hypertens Rep.* 2000;2:139–47.
- Hikmat F, Appel LJ. Effects of the DASH diet on blood pressure in patients with and without metabolic syndrome: results from the DASH trial. *J Hum Hypertens.* 2014;28:170–5.
- Hoeks J, Schrauwen P. Muscle mitochondria and insulin resistance: a human perspective. *Trends Endocrinol Metab.* 2012;23(9):444–50.
- Holland WL, Miller RA, Wang ZV, Sun K, Barth BM, Bui HH, et al. Receptor-mediated activation of ceramidase activity initiates the pleiotropic actions of adiponectin. *Nat Med.* 2011;17(1):55–63.
- Homsí R, Sprinkart AM, Gieseke J, Yucel S, Meier-Schroers M, Luetkens J, et al. 3D-Dixon cardiac magnetic resonance detects an increased epicardial fat volume in hypertensive men with myocardial infarction. *Eur J Radiol.* 2016;85(5):936–42.
- Hotamisligil GS, Shargill NS, Spiegelman BM. Adipose expression of tumor necrosis factor- $\alpha$ : direct role in obesity-linked insulin resistance. *Science.* 1993;259(5091):87–91.
- Hu G, Qiao Q, Tuomilehto J, Balkau B, Borch-Johnsen K, Pyorala K, DECODE Study Group. Prevalence of the metabolic syndrome and its relation to all-cause and cardiovascular mortality in nondiabetic European men and women. *Arch Intern Med.* 2004;164(10):1066–76.
- Huang-Doran I, Sleigh A, Rochford JJ, O’Rahilly S, Savage DB. Lipodystrophy: metabolic insights from a rare disorder. *J Endocrinol.* 2010;207(3):245–55.
- Hue L, Taegtmeyer H. The Randle cycle revisited: a new head for an old hat. *Am J Physiol Endocrinol Metab.* 2009;297:E578–91.
- Iacobellis G. Local and systemic effects of the multifaceted epicardial adipose tissue depot. *Nat Rev Endocrinol.* 2015;11(6):363–71.

- Imai Y, Fusco A, Suzuki Y, Lesniak MA, D'Alfonso R, Sesti G. Variant sequences of insulin receptor substrate-1 in patients with noninsulin-dependent diabetes mellitus. *J Clin Endocrinol Metab.* 1994;79:1655–8.
- Inzucchi SE, Bergenstal RM, Buse JB, Diamant M, Ferrannini E, Nauck M, et al. Management of hyperglycemia in type 2 diabetes, 2015: a patient-centered approach: update to a position statement of the American Diabetes Association and the European Association for the Study of diabetes. *Diabetes Care.* 2015;38:140–9.
- Itani SI, Ruderman NB, Schmieder F, Boden G. Lipid-induced insulin resistance in human muscle is associated with changes in diacylglycerol, protein kinase C, and I $\kappa$ B $\alpha$ . *Diabetes.* 2002;51(7):2005–11.
- Jacobson TA, Ito MK, Maki KC, Orringer CE, Bays HE, Jones PH, et al. National lipid association recommendations for patient-centered management of dyslipidemia: part 1 – full report. *J Clin Lipidol.* 2015;9:129–69.
- James PA, Oparil S, Carter BL, Cushman WC, Dennison-Himmelfarb C, Handler J, et al. 2014 evidence-based guideline for the management of high blood pressure in adults: report from the panel members appointed to the eighth joint National Committee (JNC 8). *JAMA.* 2014;311(5):507–20.
- Janghorbani M, Amini M. Metabolic syndrome in first degree relatives of patients with type 2 diabetes: incidence and risk factors. *Diabetes Metab Syndr.* 2011;5(4):201–6.
- Jarcho JA, Keaney JF Jr. Proof that lower is better—LDL cholesterol and IMPROVE-IT. *N Engl J Med.* 2015;372:2448–50.
- Jensen MD, Haymond MW, Rizza RA, Cryer PE, Miles JM. Influence of body fat distribution on free fatty acid metabolism in obesity. *J Clin Invest.* 1989;83(4):1168–73.
- Jensen MD. Is visceral fat involved in the pathogenesis of the metabolic syndrome? Human model. *Obesity (Silver Spring).* 2006;14(Suppl 1):20S–4S.
- Jensen MD. Role of body fat distribution and the metabolic complications of obesity. *J Clin Endocrinol Metab.* 2008;93(Suppl 1):S57–63.
- Jornayvaz FR, Samuel VT, Shulman GI. The role of muscle insulin resistance in the pathogenesis of atherogenic dyslipidemia and nonalcoholic fatty liver disease associated with the metabolic syndrome. *Annu Rev Nutr.* 2010;30:273–90.
- Kamide K. Role of renin-angiotensin-aldosterone system in metabolic syndrome and obesity-related hypertension. *Curr Hypertens Rev.* 2014. [E-pub ahead of print].
- Karastergiou K, Fried SK, Xie H, Lee MJ, Divoux A, Rosencrantz MA, et al. Distinct developmental signatures of human abdominal and gluteal subcutaneous adipose tissue depots. *J Clin Endocrinol Metab.* 2013;98(1):362–71.
- Karpe F, Pinnick KE. Biology of upper-body and lower-body adipose tissue – link to whole-body phenotypes. *Nat Rev Endocrinol.* 2015;11(2):90–100.
- Kastelein JJ, van der Steeg WA, Holme I, Gaffney M, Cater NB, Barter P, TNT Study Group, IDEAL Study Group, et al. Lipids, apolipoproteins, and their ratios in relation to cardiovascular events with statin treatment. *Circulation.* 2008;117(23):3002–9.
- Kawanaka K, Han DH, Gao J, Nolte LA, Holloszy JO. Development of glucose-induced insulin resistance in muscle requires protein synthesis. *J Biol Chem.* 2001;276(23):20101–7.
- Kazlauskienė L, Butnorienė J, Norkus A. Metabolic syndrome related to cardiovascular events in a 10-year prospective study. *Diabetol Metab Syndr.* 2015;7:102.
- Kelley DE, He J, Menshikova EV, Ritov VB. Dysfunction of mitochondria in human skeletal muscle in type 2 diabetes. *Diabetes.* 2002;51(10):2944–50.
- Kesäniemi YA, Beltz WF, Grundy SM. Comparisons of metabolism of apolipoprotein B in normal subjects, obese patients, and patients with coronary heart disease. *J Clin Invest.* 1985;76(2):586–95.
- Kim JY, van de Wall E, Laplante M, Azzara A, Trujillo ME, Hofmann SM, et al. Obesity-associated improvements in metabolic profile through expansion of adipose tissue. *J Clin Invest.* 2007;117(9):2621–37.
- Kissebah AH, Krakower GR. Regional adiposity and morbidity. *Physiol Rev.* 1994;74:761–811.
- Klein BE, Klein R, Lee KE. Components of the metabolic syndrome and risk of cardiovascular disease and diabetes in beaver dam. *Diabetes Care.* 2002;25(10):1790–4.

- Klötting N, Blüher M. Adipocyte dysfunction, inflammation and metabolic syndrome. *Rev Endocr Metab Disord*. 2014;15(4):277–87.
- Knowler WC, Barrett-Connor E, Fowler SE, Hamman RF, Lachin JM, Walker EA, et al. Reduction in the incidence of type 2 diabetes with lifestyle intervention or metformin. *N Engl J Med*. 2002;346:393–403.
- Knowler WC, Fowler SE, Hamman RF, Christophi CA, Hoffman HJ, Brenneman AT, Diabetes Prevention Program Research Group, et al. 10-year follow-up of diabetes incidence and weight loss in the diabetes prevention program outcomes study. *Lancet*. 2009;374(9702):1677–86.
- Kolodgie FD, Gold HK, Burke AP, Fowler DR, Kruth HS, Weber DK, et al. Intraplaque hemorrhage and progression of coronary atheroma. *N Engl J Med*. 2003;349(24):2316–25.
- Komatsu M, Takei M, Ishii H, Sato Y. Glucose-stimulated insulin secretion: a newer perspective. *Journal of Diabetes Investigation*. 2013;4(6):511–6.
- Krotkiewski M, Björntorp P, Sjöström L, Smith U. Impact of obesity on metabolism in men and women. Importance of regional adipose tissue distribution. *J Clin Invest*. 1983;72(3):1150–62.
- Kubota N, Yano W, Kubota T, Yamauchi T, Itoh S, Kumagai H, et al. Adiponectin stimulates AMP-activated protein kinase in the hypothalamus and increases food intake. *Cell Metab*. 2007;6(1):55–68.
- Kuk JL, Katzmarzyk PT, Nichaman MZ, Church TS, Blair SN, Ross R. Visceral fat is an independent predictor of all-cause mortality in men. *Obesity*. 2006;14(2):336–42.
- Lee BC, Lee WJ, Lo SC, Hsu HC, Chien KL, Chang YC, et al. The ratio of epicardial to body fat improves the prediction of coronary artery disease beyond calcium and Framingham risk scores. *Int J Cardiovasc Imaging*. 2016;32(Supplement 1):117–27.
- Lee J, Ozcan U. Unfolded protein response signaling and metabolic diseases. *J Biol Chem*. 2014;289(3):1203–11.
- Lee R, Wong TY, Sabanayagam C. Epidemiology of diabetic retinopathy, diabetic macular edema and related vision loss. *Eye Vis (Lond)*. 2015;2:17.
- Lehr S, Hartwig S, Sell H. Adipokines: a treasure trove for the discovery of biomarkers for metabolic disorders. *Proteomics Clin Appl*. 2012;6(1–2):91–101.
- Leon B, Jenkins S, Pepin K, Chaudhry H, Smith K, Zalos G, et al. Insulin and extremity muscle mass in overweight and obese women. *Int J Obes*. 2013;37:1560–4.
- Li YM, Mitsuhashi T, Wojciechowicz D, Shimizu N, Li J, Stitt A, et al. Molecular identity and cellular distribution of advanced glycation endproduct receptors: relationship of p60 to OST-48 and p90 to 80K-H membrane proteins. *Proc Natl Acad Sci U S A*. 1996;93(20):11047–52.
- Lithell HO. Hyperinsulinemia, insulin resistance, and the treatment of hypertension. *Am J Hypertens*. 1996;9:150S–4S.
- Lorenzo C, Okoloise M, Williams K, Stern MP, Haffner SM, Study SAH. The metabolic syndrome as predictor of type 2 diabetes: the San Antonio heart study. *Diabetes Care*. 2003;26(11):3153–9.
- Lowell BB, Shulman GI. Mitochondrial dysfunction and type 2 diabetes. *Science*. 2005;307(5708):384–7.
- Manolopoulos KN, Karpe F, Frayn KN. Gluteofemoral body fat as a determinant of metabolic health. *Int J Obes*. 2010;34:949–59.
- Matsushima T, Nakaya N, Mizuno K, Ohashi Y, Teramoto T, Yokoyama S, et al. The effect of low-dose pravastatin in metabolic syndrome for primary prevention of cardiovascular disease in Japan: a post hoc analysis of the MEGA study. *J Cardiovasc Pharmacol Ther*. 2012;17:153–8.
- Matsuzawa Y, Funahashi T, Nakamura T. The concept of metabolic syndrome: contribution of visceral fat accumulation and its molecular mechanism. *J Atheroscler Thromb*. 2011;18:629–39.
- McLellan AC, Thornalley PJ, Benn J, Sonksen PH. Glyoxalase system in clinical diabetes mellitus and correlation with diabetic complications. *Clin Sci (Lond)*. 1994;87(1):21–9.
- Meis SB, Schuster D, Gaillard T, Osei K. Metabolic syndrome in nondiabetic, obese, first-degree relatives of African American patients with type 2 diabetes: African American triglycerides-HDL-C and insulin resistance paradox. *Ethn Dis*. 2006;16(4):830–6.

- Miettinen H, Salomaa V. Diabetes and macrovascular disease. *J Cardiovasc Risk*. 1997;4(2):76–82.
- Miller NE. CETP inhibitors and cardiovascular disease: time to think again. *F1000 Res*. 2014;3:124.
- Morino K, Petersen KF, Dufour S, Befroy D, Frattini J, Shatzkes N, et al. Reduced mitochondrial density and increased IRS-1 serine phosphorylation in muscle of insulin-resistant offspring of type 2 diabetic parents. *J Clin Invest*. 2005;115(12):3587–93.
- Mottillo S, Filion KB, Genest J, Joseph L, Pilote I, Poirier P, et al. The metabolic syndrome and cardiovascular risk: a systematic review and meta-analysis. *J Am Coll Cardiol*. 2010;56(14):1113–32.
- Nathan DM. Diabetes: advances in diagnosis and treatment. *JAMA*. 2015;314(10):1052–62.
- National Cholesterol Education Program (NCEP) Expert Panel on Detection, Evaluation, and Treatment of High Blood Cholesterol in Adults (Adult Treatment Panel III). Third report of the National Cholesterol Education Program (NCEP) expert panel on detection, evaluation, and treatment of high blood cholesterol in adults (adult treatment panel III) final report. *Circulation*. 2002;106(25):3143–421.
- Neeper M, Schmidt AM, Brett J, Yan SD, Wang F, Pan YC, et al. Cloning and expression of a cell surface receptor for advanced glycosylation end products of proteins. *J Biol Chem*. 1992;267(21):14998–5004.
- Nelson BA, Robinson KA, Buse MG. Defective Akt activation is associated with glucose- but not glucosamine-induced insulin resistance. *Am J Physiol Endocrinol Metab*. 2002;282(3):E497–506.
- Nelson RH, Basu R, Johnson CM, Rizza RM, Miles JM. Splanchnic spillover of extracellular lipase-generated fatty acids in overweight and obese humans. *Diabetes*. 2007;56(12):2878–84.
- Ng M, Fleming T, Robinson M, Thomson B, Graetz N, Margono C, et al. Global, regional, and national prevalence of overweight and obesity in children and adults during 1980–2013: a systematic analysis for the global burden of disease study 2013. *Lancet*. 2014;384(9945):766–81.
- Nie L, Wang J, Clark LT, Tang A, Vega GL, Grundy SM, et al. Body mass index and hepatic lipase gene (LIPC) polymorphism jointly influence postheparin plasma hepatic lipase activity. *J Lipid Res*. 1998;39(5):1127–30.
- Nielsen S, Guo ZK, Johnson CM, Hensrud DD, Jensen MD. Splanchnic lipolysis in human obesity. *J Clin Invest*. 2004;113(11):1582–8.
- Norris JM, Rich SS. Genetics of glucose homeostasis: implications for insulin resistance and metabolic syndrome. *Arterioscler Thromb Vasc Biol*. 2012;32:2091–6.
- Osborn O, Olefsky JM. The cellular and signaling networks linking the immune system and metabolism in disease. *Nat Med*. 2012;18:363–74.
- Park CW. Diabetic kidney disease: from epidemiology to clinical perspectives. *Diabetes Metab J*. 2014;38(4):252–60.
- Park YW, Zhu S, Palaniappan L, Heshka S, Carnethon MR, Heymsfield SB. The metabolic syndrome: prevalence and associated risk factor findings in the US population from the third National Health and nutrition examination survey, 1988–1994. *Arch Intern Med*. 2003;163(4):427–36.
- Peiris AN, Hennes MI, Evans DJ, Wilson CR, Lee MB, Kissebah AH. Relationship of anthropometric measurements of body fat distribution to metabolic profile in premenopausal women. *Acta Med Scand Suppl*. 1988;723:179–88.
- Perseghin G, Price TB, Petersen KF, Roden M, Cline GW, Gerow K, et al. Increased glucose transport-phosphorylation and muscle glycogen synthesis after exercise training in insulin-resistant subjects. *N Engl J Med*. 1996;335(18):1357–62.
- Petersen KF, Befroy D, Dufour S, Dziura J, Ariyan C, Rothman DL, et al. Mitochondrial dysfunction in the elderly: possible role in insulin resistance. *Science*. 2003;300(5622):1140–2.
- Petersen KF, Dufour S, Befroy D, Garcia R, Shulman GI. Impaired mitochondrial activity in the insulin-resistant offspring of patients with type 2 diabetes. *N Engl J Med*. 2004;350:664–71.
- Petersen KF, Dufour S, Morino K, Yoo PS, Cline GW, Shulman GI. Reversal of muscle insulin resistance by weight reduction in young, lean, insulin-resistant offspring of parents with type 2 diabetes. *Proc Natl Acad Sci U S A*. 2012;109(21):8236–40.

- Petersen KF, Dufour S, Savage DB, Bilz S, Solomon G, Yonemitsu S, et al. The role of skeletal muscle insulin resistance in the pathogenesis of the metabolic syndrome. *Proc Natl Acad Sci U S A*. 2007;104:12587–94.
- Petersen KF, Dufour S, Shulman GI. Decreased insulin-stimulated ATP synthesis and phosphate transport in muscle of insulin-resistant offspring of type 2 diabetic parents. *PLoS Med*. 2005;2(9):e233.
- Petersen KF, Morino K, Alves TC, Kibbey RG, Dufour S, Sono S, et al. Effect of aging on muscle mitochondrial substrate utilization in humans. *Proc Natl Acad Sci U S A*. 2015;112(36):11330–4.
- Pignone M, Alberts MJ, Colwell JA, Cushman M, Inzucchi SE, Mukherjee D, et al. Aspirin for primary prevention of cardiovascular events in people with diabetes: a position statement of the American Diabetes Association, a scientific statement of the American Heart Association, and an expert consensus document of the American College of Cardiology Foundation. *DiabetesCare*. 2010;33:1395–402.
- Pinnick KE, Nicholson G, Manolopoulos KN, McQuaid SE, Valet P, Frayn KN, MolPAGE Consortium, MI MC, Holmes CC, Karpe F, et al. Distinct developmental profile of lower-body adipose tissue defines resistance against obesity-associated metabolic complications. *Diabetes*. 2014;63(11):3785–97.
- Puigserver P, Rhee J, Donovan J, Walkey CJ, Yoon JC, Oriente F, et al. Insulin-regulated hepatic gluconeogenesis through FOXO1-PGC-1 $\alpha$  interaction. *Nature*. 2003;423(6939):550–5.
- Pyyrälä K, Ballantyne CM, Gumbiner B, Lee MW, Shah A, Davies MJ, et al. Reduction of cardiovascular events by simvastatin in nondiabetic coronary heart disease patients with and without the metabolic syndrome: subgroup analyses of the Scandinavian simvastatin survival study (4S). *Diabetes Care*. 2004;27:1735–40.
- Randle PJ, Garland PB, Hales CN, Newsholme EA. The glucose fatty-acid cycle. Its role in insulin sensitivity and the metabolic disturbances of diabetes mellitus. *Lancet*. 1963;1:785–9.
- Randle PJ, Priestman DA, Mistry SC, Halsall A. Glucose fatty acid interactions and the regulation of glucose disposal. *J Cell Biochem*. 1994;55(Suppl):1–11.
- Rankinen T, Sarzynski MA, Ghosh S, Boucharad C. Are there genetic paths common to obesity, cardiovascular disease outcomes, and cardiovascular risk factors? *Circ Res*. 2015;116(5):909–22.
- Rao A, Pandya V, Whaley-Connell A. Obesity and insulin resistance in resistant hypertension: implications for the kidney. *Adv Chronic Kidney Dis*. 2015;22:211–7.
- Reaven GM, Lerner RL, Stern MP, Farquhar JW. Role of insulin in endogenous hypertriglyceridemia. *J Clin Invest*. 1967;46(11):1756–67.
- Reaven GM. Banting lecture 1988. Role of insulin resistance in human disease. *Diabetes*. 1988;37(12):1595–607.
- Reaven GM. Insulin resistance, the insulin resistance syndrome, and cardiovascular disease. *Panminerva Med*. 2005;47(4):201–10.
- Reaven GM. Insulin resistance/compensatory hyperinsulinemia, essential hypertension, and cardiovascular disease. *J Clin Endocrinol Metab*. 2003;88(6):2399–403.
- Reaven GM. Insulin resistance: the link between obesity and cardiovascular disease. *Med Clin North Am*. 2011;95(5):875–92.
- Reaven GM. Pathophysiology of insulin resistance in human disease. *Physiol Rev*. 1995;75(3):473–86.
- Reaven GM. Relationship between insulin resistance and hypertension. *Diabetes Care*. 1991;14(Suppl 4):33–8.
- Reisin E, Abel R, Modan M, Silverberg DS, Eliahou HE, Modan B. Effect of weight loss without salt restriction on the reduction of blood pressure in overweight hypertensive patients. *N Engl J Med*. 1978;298:1–6.
- Renström F, Burén J, Svensson M, Eriksson JW. Insulin resistance induced by high glucose and high insulin precedes insulin receptor substrate 1 protein depletion in human adipocytes. *Metabolism*. 2007;56(2):190–8.

- Ricci C, Gaeta M, Rausa E, Macchitella Y, Bonavina L. Early impact of bariatric surgery on type II diabetes, hypertension, and hyperlipidemia: a systematic review, meta-analysis and meta-regression on 6,587 patients. *Obes Surg*. 2014;24:522–8.
- Richter EA, Ruderman NB. AMPK and the biochemistry of exercise: implications for human health and disease. *Biochem J*. 2009;418(2):261–75.
- Ridker PM, Lüscher TF. Anti-inflammatory therapies for cardiovascular disease. *Eur Heart J*. 2014;35:1782–91.
- Ridker PM, Thuren T, Zalewski A, Libby P. Interleukin-1 $\beta$  inhibition and the prevention of recurrent cardiovascular events: rationale and design of the Canakinumab anti-inflammatory thrombosis outcomes study (CANTOS). *Am Heart J*. 2011;162:597–605.
- Robinson JG, Farnier M, Krempf M, Bergeron J, Luc G, Averna M, et al. Efficacy and safety of alirocumab reducing lipids and cardiovascular events. *N Engl J Med*. 2015;372:1489–99.
- Robinson KA, Buse MG. Mechanisms of high-glucose/insulin-mediated desensitization of acute insulin-stimulated glucose transport and Akt activation. *Am J Physiol Endocrinol Metab*. 2008;294(5):E870–81.
- Romeo S, Kozlitina J, Xing C, Pertsemlidis A, Cox D, Pennacchio LA, et al. Genetic variation in PNPLA3 confers susceptibility to nonalcoholic fatty liver disease. *Nat Genet*. 2008;40(12):1461–5.
- Roust LR, Jensen MD. Postprandial free fatty acid kinetics are abnormal in upper body obesity. *Diabetes*. 1993;42:1567–73.
- Ruderman N, Chisholm D, Pi-Sunyer X, Schneider S. The metabolically obese, normal-weight individual revisited. *Diabetes*. 1998;47(5):699–713.
- Ruderman NB, Carling D, Prentki M, Cacicedo JM. AMPK, insulin resistance, and the metabolic syndrome. *J Clin Invest*. 2013;123(7):2764–72.
- Ruderman NB, Saha AK, Vavvas D, Witters LA. Malonyl-CoA, fuel sensing, and insulin resistance. *Am J Phys*. 1999;276(1 Pt 1):E1–E18.
- Ruderman NB, Schneider SH, Berchtold P. The “metabolically-obese,” normal-weight individual. *Am J Clin Nutr*. 1981;34(8):1617–21.
- Rue N, Vissing J, Galbo H. Insulin resistance and increased muscle cytokine levels in patients with mitochondrial myopathy. *J Clin Endocrinol Metab*. 2014;99(10):3757–65.
- Sabatine MS, Giugliano RP, Wiviott SD, Raal FJ, Blom DJ, Robinson J, et al. Efficacy and safety of evolocumab reducing lipids and cardiovascular events. *N Engl J Med*. 2015;372:1500–9.
- Samuel VT, Petersen KF, Shulman GI. Lipid-induced insulin resistance: unravelling the mechanism. *Lancet*. 2010;375(9733):2267–77.
- Samuel VT, Shulman GI. Mechanisms for insulin resistance: common threads and missing links. *Cell*. 2012;148(5):852–71.
- Samuel VT, Shulman GI. The pathogenesis of insulin resistance: integrating signaling pathways and substrate flux. *J Clin Invest*. 2016;126(1):12–22.
- Sattar N, Gaw A, Scherbakova O, Ford I, O’Reilly DS, Haffner SM, Isles C, Macfarlane PW, Packard CJ, Cobbe SM, Shepherd J. Metabolic syndrome with and without C-reactive protein as a predictor of coronary heart disease and diabetes in the west of Scotland coronary prevention study. *Circulation*. 2003 Jul 29;108(4):414–9.
- Schwarz JM, Linfoot P, Dare D, Aghajanian K. Hepatic de novo lipogenesis in normoinsulinemic and hyperinsulinemic subjects consuming high-fat, low-carbohydrate and low-fat, high-carbohydrate isoenergetic diets. *Am J Clin Nutr*. 2003;77(1):43–50.
- Seidell JC, Bjorntorp P, Sjostrom L, Kvist H, Sannerstedt R, et al. Visceral fat accumulation in men is positively associated with insulin, glucose, and C-peptide levels, but negatively with testosterone levels. *Metabolism*. 1990;39(9):897–901.
- Semple RK, Sleight A, Murgatroyd PR, Adams CA, Bluck L, Jackson S, et al. Postreceptor insulin resistance contributes to human dyslipidemia and hepatic steatosis. *J Clin Invest*. 2009;119(2):315–22.
- Shimabukuro M, Zhou YT, Levi M, Unger RH. Fatty acid-induced beta cell apoptosis: a link between obesity and diabetes. *Proc Natl Acad Sci U S A*. 1998;95(5):2498–502.



- Shimomura I, Matsuda M, Hammer RE, Bashmakov Y, Brown MS, Goldstein JL. Decreased IRS-2 and increased SREBP-1c lead to mixed insulin resistance and sensitivity in livers of lipodystrophic and Ob/Ob mice. *Mol Cell*. 2000;6(1):77–86.
- Shinohara M, Thornalley PJ, Giardino I, Beisswenger P, Thorpe SR, Onorato J, et al. Over-expression of glyoxalase-I in bovine endothelial cells inhibits intracellular advanced glycation endproduct formation and prevents hyperglycemia-induced increases in macromolecular endocytosis. *J Clin Invest*. 1998;101(5):1142–7.
- Shulman GI. Ectopic fat in insulin resistance, dyslipidemia, and cardiometabolic disease. *N Engl J Med*. 2014a;371(12):1131–41.
- Shulman GI. Ectopic fat in insulin resistance, dyslipidemia, and cardiometabolic disease. *N Engl J Med*. 2014b;371(23):2237–8.
- Simmons RK, Alberti KG, Gale EA, Colagiuri S, Tuomilehto J, Qiao Q, et al. The metabolic syndrome: useful concept or clinical tool? Report of a WHO expert consultation. *Diabetologia*. 2010;53(4):600–5.
- Simoneau J-A, Kelley DE. Altered skeletal muscle glycolytic and oxidative capacities contribute to insulin resistance in NIDDM. *J Appl Physiol*. 1997;83:166–71.
- Sinha R, Dufour S, Petersen KF, LeBon V, Enoksson S, Ma YZ, et al. Assessment of skeletal muscle triglyceride content by (1)H nuclear magnetic resonance spectroscopy in lean and obese adolescents: relationships to insulin sensitivity, total body fat, and central adiposity. *Diabetes*. 2002;51(4):1022–7.
- Smedsrød B, Melkko J, Araki N, Sano H, Horiuchi S. Advanced glycation end products are eliminated by scavenger-receptor-mediated endocytosis in hepatic sinusoidal Kupffer and endothelial cells. *Biochem J*. 1997;322(Pt 2):567–73.
- SPRINT Research Group, Wright JT Jr, Williamson JD, Whelton PK, Snyder JK, Sink KM, Rocco MV, Reboussin DM, Rahman M, Oparil S, Lewis CE, Kimmel PL, Johnson KC, Goff DC Jr, Fine LJ, Cutler JA, Cushman WC, Cheung AK, Ambrosius WT. A randomized trial of intensive versus standard blood-pressure control. *N Engl J Med*. 2015 Nov 26;373(22):2103–16.
- Standl E, Erbach M, Schnell O. What should be the anti-hypertensive drug of choice in diabetic patients and should we avoid drugs that increase glucose levels? Pro and cons. *Diabetes Metab Res Rev*. 2012;28(Suppl 2):60–6.
- Stanhope KL, Bremer AA, Medici V, Nakajima K, Ito Y, Nakano T, et al. Consumption of fructose and high fructose corn syrup increase postprandial triglycerides, LDL-cholesterol, and apolipoprotein-B in young men and women. *J Clin Endocrinol Metab*. 2011;96(10):E1596–605.
- Stanhope KL, Schwarz JM, Havel PJ. Adverse metabolic effects of dietary fructose: results from the recent epidemiological, clinical, and mechanistic studies. *Curr Opin Lipidol*. 2013;24(3):198–206.
- Stanhope KL, Schwarz JM, Keim NL, Griffen SC, Bremer AA, Graham JL, et al. Consuming fructose-sweetened, not glucose-sweetened, beverages increases visceral adiposity and lipids and decreases insulin sensitivity in overweight/obese humans. *J Clin Invest*. 2009;119(5):1322–34.
- Stein DT, Esser V, Stevenson BE, Lane KE, Whiteside JH, Daniels MB, et al. Essentiality of circulating fatty acids for glucose-stimulated insulin secretion in the fasted rat. *J Clin Invest*. 1996;97(12):2728–35.
- Steinberg GR, Kemp BE. AMPK in health and disease. *Physiol Rev*. 2009;89(3):1025–78.
- Stirnadel H, Lin X, Ling H, Song K, Barter P, Kesaniemi YA, et al. Genetic and phenotypic architecture of metabolic syndrome-associated components in dyslipidemic and normolipidemic subjects: the GEMS study. *Atherosclerosis*. 2008;197(2):868–76.
- Swinburn BA, Sacks G, Lo SK, Westterterp KR, Rush EC, Rosenbaum M, et al. Estimating the changes in energy flux that characterize the rise in obesity prevalence. *Am J Clin Nutr*. 2009;89:1723–8.
- Szczepaniak LS, Victor RG, Mathur R, Nelson MD, Szczepaniak EW, Tyer N, et al. Pancreatic steatosis and its relationship to  $\beta$ -cell dysfunction in humans: racial and ethnic variations. *Diabetes Care*. 2012;35(11):2377–83.

- Szendroedi J, Yoshimura T, Phielix E, Koliaki C, Marcucci M, Zhang D, et al. Role of diacylglycerol activation of PKC $\theta$  in lipid-induced muscle insulin resistance in humans. *Proc Natl Acad Sci U S A*. 2014;111(26):9597–602.
- Tan GD, Goossens GH, Humphreys SM, Vidal H, Karpe F. Upper and lower body adipose tissue function: a direct comparison of fat mobilization in humans. *Obes Res*. 2004;12(1):114–8.
- Tappy L, Lê KA. Metabolic effects of fructose and the worldwide increase in obesity. *Physiol Rev*. 2010;90(1):23–46.
- Tardif JC, L'allier PL, Ibrahim R, Grégoire JC, Nozza A, Cossette M, et al. Treatment with 5-lipoxygenase inhibitor VIA-2291 (Atreleuton) in patients with recent acute coronary syndrome. *Circ Cardiovasc Imaging*. 2010;3:298–307.
- Tchernof A, Després JP. Pathophysiology of human visceral obesity: an update. *Physiol Rev*. 2013;93:359–404.
- Thomas F, Smith GC, Lu J, Babor R, Booth M, Beban G, et al. Differential acute impacts of sleeve gastrectomy, roux-en-Y gastric bypass surgery and matched caloric restriction diet on insulin secretion, insulin effectiveness and non-esterified fatty acid levels among patients with type 2 diabetes. *Obes Surg*. 2016. <https://doi.org/10.1007/s11695-015-2038-3>.
- Toth PP. Triglyceride-rich lipoproteins as a causal factor for cardiovascular disease. *Vasc Health Risk Manag*. 2016;12:171–83.
- Tuck ML, Sowers J, Dornfeld L, Kledzik G, Maxwell M. The effect of weight reduction on blood pressure, plasma renin activity, and plasma aldosterone levels in obese patients. *N Engl J Med*. 1981;304:930–3.
- Tulloch-Reid MK, Williams DE, Looker HC, Hanson RL, Knowler WC. Do measures of body fat distribution provide information on the risk of type 2 diabetes in addition to measures of general obesity? Comparison of anthropometric predictors of type 2 diabetes in pima Indians. *Diabetes Care*. 2003;26:2556–61.
- Unger RH, Zhou YT. Lipotoxicity of beta-cells in obesity and in other causes of fatty acid spillover. *Diabetes*. 2001;50(Suppl 1):S118–21.
- US Preventive Services Task Force. Aspirin for the prevention of cardiovascular disease: U.S. preventive services task force recommendation statement. *Ann Intern Med*. 2009;150:396–404.
- Uyeda K, Yamashita H, Kawaguchi T. Carbohydrate responsive element-binding protein (ChREBP): a key regulator of glucose metabolism and fat storage. *Biochem Pharmacol*. 2002;63(12):2075–80.
- van Loon LJ, Koopman R, Manders R, van der Weegen W, van Kranenburg GP, Keizer HA. Intramyocellular lipid content in type 2 diabetes patients compared with overweight sedentary men and highly trained endurance athletes. *Am J Physiol Endocrinol Metab*. 2004;287(3):E558–65.
- Vatner DF, Majumdar SK, Kumashiro N, Petersen MC, Rahimi Y, Gattu AK, et al. Insulin-independent regulation of hepatic triglyceride synthesis by fatty acids. *Proc Natl Acad Sci U S A*. 2015;112(4):1143–8.
- Vega GL, Adams-Huet B, Peshock R, Willett D, Shah B, Grundy SM. Influence of body fat content and distribution on variation in metabolic risk. *J Clin Endocrinol Metab*. 2006;91(11):4459–66.
- Vega GL, Chandalia M, Szczepaniak LS, Grundy SM. Metabolic correlates of nonalcoholic fatty liver in women and men. *Hepatology*. 2007;46(3):716–22.
- Vinik A, Flemmer M. Diabetes and macrovascular disease. *J Diabetes Complicat*. 2002;16(3):235–45.
- Vlassara H, Li YM, Imani F, Wojciechowicz D, Yang Z, Liu FT, et al. Identification of galectin-3 as a high-affinity binding protein for advanced glycation end products (AGE): a new member of the AGE-receptor complex. *Mol Med*. 1995;1(6):634–46.
- Weisberg SP, McCann D, Desai M, Rosenbaum M, Leibel RL, Ferrante AW Jr. Obesity is associated with macrophage accumulation in adipose tissue. *J Clin Invest*. 2003;112:1796–808.
- Welle S, Forbes GB, Statt M, Barnard RR, Amatruda JM. Energy expenditure under free-living conditions in normal-weight and overweight women. *Am J Clin Nutr*. 1992;55:14–21.

- Wilhelm SM, Young J, Kale-Pradhan PB. Effect of bariatric surgery on hypertension: a meta-analysis. *Ann Pharmacother*. 2014;48:674–82.
- Williams KJ, Tabas I. The response-to-retention hypothesis of early atherogenesis. *Arterioscler Thromb Vasc Biol*. 1995;15(5):551–61.
- Winder WW, Arogyasami J, Elayan IM, Cartmill D. Time course of exercise-induced decline in malonyl-CoA in different muscle types. *Am J Physiol Endocrinol Metab*. 1990;259:E266–71.
- Winder WW, Holmes BF, Rubink DS, Jensen EB, Chen M, Holloszy JO. Activation of AMP-activated protein kinase increases mitochondrial enzymes in skeletal muscle. *J Appl Physiol*. 2000;88:2219–26.
- Wolfe RR. Metabolic interactions between glucose and fatty acids in humans. *Am J Clin Nutr*. 1998;67(3 Suppl):519S–26S.
- Wu FZ, Wu CC, Kuo PL, Wu MT. Differential impacts of cardiac and abdominal ectopic fat deposits on cardiometabolic risk stratification. *BMC Cardiovasc Disord*. 2016;16:20.
- Ye R, Ni M, Wang M, Luo S, Zhu G, Chow RH, et al. Inositol 1,4,5-trisphosphate receptor 1 mutation perturbs glucose homeostasis and enhances susceptibility to diet-induced diabetes. *J Endocrinol*. 2011;210(2):209–17.
- Zheng D, MacLean PS, Pohnert SC, Knight JB, Olson AL, Winder WW, et al. Regulation of muscle GLUT-4 transcription by AMP-activated protein kinase. *J Appl Physiol*. 2001;91:1073–83.
- Zreikat HH, Harpe SE, Slattum PW, Mays DP, Essah PA, Cheang KI. Effect of renin–angiotensin system inhibition on cardiovascular events in older hypertensive patients with metabolic syndrome. *Metabolism*. 2014;63:392–9.
- Zurlo F, Larson K, Bogardus C, Ravussin E. Skeletal muscle metabolism is a major determinant of resting energy expenditure. *J Clin Invest*. 1990;86(5):1423–7.



# Hypertension and Diabetes

# 4

Colleen Majewski and George L. Bakris

## Contents

Introduction .....	110
Pathophysiology of Hypertension and Diabetes Mellitus .....	110
Goals of Blood Pressure Treatment .....	113
Effect of Antihypertensive Agents on Diabetes .....	115
Approach to Treatment .....	116
Summary .....	123
References .....	124

## Abstract

Hypertension is seen in most people with diabetes mellitus and accentuates cardiovascular risk and accelerates development of kidney function decline. In most cases there is a genetic predisposition to develop hypertension in people with diabetes compounded by the presence of obesity and high sodium intake. While reduction in weight and sodium intake ameliorates elevations in blood pressure in most cases medications are needed. With proper control of blood pressure to levels below 140/90 mmHg, there has been a marked reduction in cardiovascular events and a slowing of kidney disease progression from 10–12 mL/min/year before decline in estimated glomerular filtration rate before 1985 to 2–4 mL/min/year decline currently. Moreover, those born after 1980 with type 1 diabetes have a 40% lower risk of developing end stage kidney disease than those born previously. Treatment of hypertension depends on stage of kidney disease. A low sodium, i.e., <2300 mg/day, diet, at least 6–7 h of uninterrupted sleep, and weight loss are the cornerstones of therapy. Drug treatment will be much less effective if these lifestyle issues are not in place. Those with macroalbuminuria,

C. Majewski · G. L. Bakris (✉)

ASH Comprehensive Hypertension Center, Section of Endocrinology, Diabetes and Metabolism, The University of Chicago Medicine, Chicago, IL, USA

e-mail: [gbakris@medicine.bsd.uchicago.edu](mailto:gbakris@medicine.bsd.uchicago.edu)

© Springer Nature Switzerland AG 2020

E. Bonora, R. A. DeFronzo (eds.), *Diabetes Complications, Comorbidities and Related Disorders*, Endocrinology, [https://doi.org/10.1007/978-3-030-36694-0\\_5](https://doi.org/10.1007/978-3-030-36694-0_5)

109

i.e., greater than 300 mg/day and a blood pressure  $\geq 140/90$  mmHg, must be treated with an angiotensin-converting enzyme inhibitor as part of the regimen. In all others it is important to lower blood pressure to  $< 140/90$  mmHg and either a renin-angiotensin system blocker, thiazide-type diuretic, or calcium channel antagonist may be used alone or in combination.

---

**Keywords**

Hypertension · Nephropathy · Blood pressure · Diabetes

---

## Introduction

More than 75% of adults with diabetes have hypertension (defined as a blood pressure [BP]  $> 130/80$  mmHg) or are using antihypertensive medication (National Kidney Foundation 2007). In the natural history of type 1 diabetes, development of an elevated blood pressure is a major predictor of nephropathy and future declines in kidney function (National Kidney Foundation 2007; Bakris 2004). In contrast, hypertension is already evident in most patients with type 2 diabetes at the time of diagnosis. The implications of hypertension on cardiovascular risk however are similar in both types of diabetes (National Kidney Foundation 2007; Sarafidis and Bakris 2008). Mortality is increased 7.2-fold when hypertension is present in patients with diabetes (National Kidney Foundation 2007).

Hypertension is the most prevalent risk factor for the development of cardiovascular and kidney disease (National Kidney Foundation 2007; Stamler et al. 1993). The prevalence of hypertension is estimated at about 30% of the adult population in developed countries and is predicted to increase by almost 60% in the next two decades (Hajjar and Kotchen 2003; Kearney et al. 2005). Diabetes is a major risk factor for cardiovascular disease and the most common cause of kidney failure in the Western world (National Kidney Foundation 2007; Buse et al. 2007). Moreover, cardiovascular mortality and morbidity is increased substantially in the presence of diabetes (Nag et al. 2007).

---

## Pathophysiology of Hypertension and Diabetes Mellitus

Hypertension is a genetic disease expressed phenotypically as elevated blood pressure earlier in lifespan than would occur with normal aging (Giles et al. 2009). Expression is based on environmental factors such as diet and exercise (Giles et al. 2009). It is a key component of the metabolic syndrome, which is a collection of cardiovascular risk factors including abdominal obesity, impaired glucose tolerance, and dyslipidemia (Sharma 2003; Kannel et al. 1993).

Several studies demonstrate a clear relationship between obesity and hypertension (Kannel et al. 1993; Must et al. 1999). Hypertension and obesity rates are increasing in developed countries with hypertension being the most prevalent risk

factor contributing to the development of cardiovascular disease and chronic kidney disease (CKD) (National Kidney Foundation 2007; Giles et al. 2009; Egan et al. 2010).

Abdominal obesity is a major risk factor in the development of hypertension (Thompson et al. 1999; Gorzelniak et al. 2002). Several mechanisms contribute to the development of hypertension in obese individuals. Excess weight gain is associated with sodium and fluid retention as well as increases in components of the renin-angiotensin-aldosterone system (RAAS), and both contribute to the development of hypertension (Robles et al. 1993). A study of obese dogs treated with RAAS blockers resulted in a natriuresis, volume loss, and reduced arterial pressure (Robles et al. 1993). Studies of obese subjects demonstrate increases in plasma renin activity, plasma angiotensinogen (AGT), angiotensin-converting enzyme (ACE) activity, plasma angiotensin (Ang) II, and aldosterone levels (Hall 2003; Goodfriend and Calhoun 2004). Weight loss decreases these RAAS components (Engeli et al. 2005).

Adipose tissue itself produces angiotensinogen (AGT), and AGT concentration is correlated with body mass index and hypertension (Massiera et al. 2001). Furthermore, there is a correlation between 24-h blood pressure and the expression of genes related to the RAAS in adipocytes (Gorzelniak et al. 2002; Sharma 2002). AGT and Ang II also play a local role in adipocyte differentiation and metabolism (Sharma 2002; Sharma et al. 2002).

The contributing factors in the pathogenesis of hypertension in diabetes are multifactorial. For many years, it has been recognized that hypertension is common to both obese subjects and those with type 2 diabetes (Hypertension in Diabetes Study Group 1993). Blood pressure elevations in both these groups may be, in part, due to the presence of insulin resistance and resultant hyperinsulinemia as well as increased salt sensitivity. Support for this proposal is evident from studies of behaviors that improve insulin action, such as weight loss and increased physical activity and the resultant reduction in blood pressure into the normal range (Sowers et al. 1982; Tuck et al. 1981; Becton et al. 2012). Additionally, studies that are more recent demonstrate blunting of vasodilator responses to known stimuli and reduced nitric oxide release; these factors are associated with increases in salt sensitivity, i.e., both systolic and diastolic blood pressure 95 increase by >5 mmHg more than someone given the same salt load of 400 mmol/day (Wedler et al. 1992; Yatabe et al. 2010).

To understand the contribution of insulin resistance in the genesis of hypertension, one has to evaluate the effects of insulin resistance and hyperinsulinemia on factors that contribute to blood pressure elevation. Insulin resistance is a metabolic disorder that is manifested by a reduction in peripheral skeletal muscle utilization of glucose, fatty acid, and protein metabolism (Kadowaki et al. 1990). Hence, higher concentrations of insulin (hyperinsulinemia) are needed to achieve the same level of glucose utilization in these tissues. Hyperinsulinemia is also associated with a number of physiologic changes in cellular function. Hyperinsulinemia may also contribute to the genesis of hypertension through its effects on sodium homeostasis and the sympathetic nervous system. Lastly, the effect of insulin on various growth factors contributes to the development of vascular injury through its potentiation of the atherosclerotic process (Liu et al. 2011).

Most obese individuals develop insulin resistance and subsequent hyperinsulinemia. Yet, they all do not develop type 2 diabetes or hypertension. The reasons for this lack of consistency with disease development are likely due to varied genetic and environmental factors.

Work by various investigators to isolate a “hypertensive gene” or group of genes has been ongoing for many years (International Consortium for Blood Pressure Genome-Wide Association Studies et al. 2011). Many candidate genes for hypertension have been found, including genes for ion channels within the kidney that affect transporters (SLC12A3, SLC12A1, KCNJ1, SCNN1A, SCNN1B, SCNN1G, CLCNKB), ion channel regulation (WNK1, WNK4, SGK1, ADD1, ADD2, GRK4), aldosterone signaling (REN, AGT, ACE, AGTR1), catecholamine pathways (TH, COMT, DBH, DRD1, DRD2, ADRB1, ADRB2, ADRB3, ADRA1A), vasoconstriction (NOS3, EDN1, EDNRA, CYP2C8), and inflammation (TGF- $\beta$ ) (Simino et al. 2012).

There are also studies investigating for genes that increase risk for development of both hypertension and diabetes. Kraja et al. evaluated the 22,161 participants in the seven studies of the STAMPEED consortium to determine if subjects with the metabolic syndrome phenotype had common genetic variants. Using genome-wide association analyses, they identified two single-nucleotide polymorphisms (SNPs) located between LOC<sub>100128354</sub> (similar to small nuclear ribonucleoprotein polypeptide G, 11q21) and MTNR1B (melatonin-receptor 1B) that were significantly associated with both elevated blood glucose and hypertension (Kraja et al. 2011).

A study by Patel et al. investigated variations in the angiotensin-converting enzyme 2 (ACE2) gene in Caucasian men and women with type 2 diabetes. ACE2 is a homologue of ACE and degrades angiotensin II to the vasodilator angiotensin I-7. The researchers found certain polymorphisms of ACE2 in men and women with type 2 diabetes that were associated with hypertension (Patel et al. 2012). Bengtsson et al. investigated polymorphisms of the ACE gene and angiotensinogen (AGT) gene and their association with hypertension and type 2 diabetes. They found the D-allele of the ACE gene ID polymorphism increases susceptibility to hypertension, particularly when associated with type 2 diabetes (Bengtsson et al. 1999). A smaller study of 69 subjects with insulin-dependent diabetes found the CC-genotype of the A1166C gene polymorphism of the angiotensin type 1 receptor gene polymorphism is associated with hypertension (van Ittersum et al. 2000).

A number of other factors have been associated with hypertension development in diabetes. Haptoglobin polymorphisms were examined in a 120-subject study, the results of which predicted the development of hypertension in patients with diabetes. The Hp1-2 genotype was the most common among those with refractory hypertension and type 2 diabetes (Wobeto et al. 2011).

Renalase is an important enzyme in catecholamine metabolism and is linked with changes associated with worsening of cardiac ischemia and kidney disease (Wu et al. 2011; Xu et al. 2005; Buraczynska et al. 2011). Buraczynska et al. found an association between the renalase gene polymorphism (C allele of rs2296545 SNP) with hypertension in 892 patients with type 2 diabetes (Buraczynska et al. 2011).

Lastly, a recent study by Groop et al. investigated the association between polymorphisms of the glycogen synthase gene and the associated risk of developing type 2 diabetes (Groop et al. 1993). These investigators found two polymorphic alleles ( $A_1$  and  $A_2$ ) in this gene located on chromosome 19. Moreover, they documented a twofold greater prevalence of hypertension among subjects without diabetes who had the  $A_2$  allele expressed. Unfortunately, no such distinction was noted in the group studied with diabetes. Note, however, that among the group with diabetes, both the  $A_1$  and  $A_2$  allelic groups had hyperinsulinemia and were hypertensive. Taken together, these studies provide evidence that supports the concept that a different “genetic load” is required for the development of either hypertension or diabetes. Specifically, each of these disorders appears to be inherited in a polygenic (i.e., to involve more than one gene) and heterogeneous (involving different constellations of disease genes in different persons) fashion. Since hypertension does not develop in all people with diabetes, the presence of certain environmental factors, i.e., diet, sedentary lifestyle, high salt intake, etc., is mostly required to express the concomitant generation of both diseases.

---

## Goals of Blood Pressure Treatment

For many years, most guidelines in the Western world uniformly recommended two blood pressure (BP) goals,  $<140/90$  mmHg for the general population and  $<130/80$  mmHg for those with diabetes or chronic kidney disease (CKD) (Chobanian et al. 2003; Mancia et al. 2007a). More recent guidelines like those from the Expert Panel Report (also called JNC 8) took a purely evidence-based approach to blood pressure guidelines and recommended a goal blood pressure of  $<140/90$  mmHg in patients with diabetes (James et al. 2014). The 2016 American Diabetes Association (ADA) Standards of Medical Care in Diabetes supported this recommendation stating that a systolic blood pressure  $<140$  mmHg is appropriate in most patients and the diastolic blood pressure should be treated to  $<90$  mmHg (Standards of Medical Care in Diabetes-2016).

Meta-analyses of all clinical trials, to date, demonstrate that reducing BP reduces risk for stroke and coronary heart disease. However, almost all prospective studies in patients with diabetes have not achieved a mean BP goal of  $<130/80$  mmHg (Staessen et al. 2005). Moreover, no trial was powered to detect a difference between two BP goals for kidney disease progression, hence, there are no trials in diabetes patients with kidney disease that fully support a BP level of  $<130/80$  mmHg. This lack of lower BP goal achievement is even true in cardiovascular diseases (CVD) outcome trials of diabetes (Table 1).

In trials like the United Kingdom Prospective Diabetes Study (UKPDS) (UKPDS Group 1998) and the Hypertension Optimal Treatment (HOT) trial (Hansson et al. 1998), the systolic BP was more than 10 mmHg higher than this lower goal. Note also that HOT had a diastolic goal set but only a fraction of the patients had diabetes. In the post hoc analysis of HOT, the lower diastolic goal of 80 mmHg did result in few CVD events but at best was hypothesis generating. Nevertheless, a benefit occurred on CVD reduction. One prospective study that achieved this lower BP



**Table 1** Achieved blood pressure values from clinical outcome trials with cardiovascular outcomes involving patients with diabetes

Clinical outcome trial	Achieved level of systolic BP (mmHg)
ACCORD (primary)	119 (intensive); 133 (conventional)
UKPDS (primary)	144 (intensive); 154 (conventional)
ACCOMPLISH (secondary)	Overall mean 133
INVEST (secondary)	144 (tight);149 (conventional)
ONTARGET (secondary)	Averaging around 140
VADT (secondary)	127 (intensive);125 (conventional)
ADVANCE (secondary)	145 (in both intensive and conventional)

Note: Intensive and conventional refer to glycemic control NOT blood pressure

goal in patients with diabetes and no overt nephropathy was the Appropriate Blood Pressure Control in Diabetes (ABCD) trial (Estacio et al. 2000). This trial demonstrated reduced cardiovascular (CV) risk, but there was no difference between the groups with a mean systolic pressure of 138 mmHg versus the intensive group at 132 mmHg. Note, however, that this trial was underpowered for a BP goal outcome.

The ACCORD trial thus provides a more definitive answer, albeit still weak because not statistically powered to assess BP differences on CV outcomes compared to conventional BP control (Accord Study Group et al. 2010). This prospective randomized trial demonstrated a separation of mean systolic blood pressure of 14 mmHg (133 mmHg vs. 119 mmHg). In spite of this sustained difference in blood pressure for more than 4 years, there was no additional benefit on the primary endpoint, i.e., CV events. There was a reduction, however, on stroke events, albeit, at a cost of a higher side effect profile from medications. Long-term follow-up of ACCORD demonstrated a significant interaction between the powered portion of the trial, i.e., glycemic control such that an analysis of the blood pressure groups in this context did show a CVD risk reduction at the lower BP goal of 120 mmHg (Margolis et al. 2014).

Post hoc analyses of the Ongoing Telmisartan Alone and in combination with Ramipril Global Endpoint Trial (ONTARGET) and International Verapamil SR – Trandolapril Study (INVEST) demonstrate, however, that the benefit of lower levels of blood pressure on CV risk reduction is lost when systolic BP levels fall below 130 mmHg (Cooper-DeHoff et al. 2010; Sleight et al. 2009). INVEST further demonstrated an increase in CV events at systolic blood pressures <115 mmHg, although 100% of these patients had coronary artery disease (Cooper-DeHoff et al. 2010). A review of all trials in patients with diabetes including the ACCORD trial made it clear that blood pressure reduction to levels below 140/90 mmHg is associated with fewer CV events; however, there is less data to support below 130/80 mmHg (Accord Study Group et al. 2010).

The Systolic Blood Pressure Intervention (SPRINT) trial which randomized over 9000 subjects to a blood pressure of less than 120 mmHg versus less than 140 mmHg challenges the most recent blood pressure guidelines. Although none of the subjects had diabetes, they all had at least one risk factor for cardiovascular disease. The trial was stopped early because of the significant reduction in the primary composite

outcome of myocardial infarction, other acute coronary syndromes, stroke, heart failure, or death from cardiovascular causes in the intensively treated blood pressure group compared to the standard group (SPRINT Research Group et al. 2015).

A number of recent meta-analyses have specifically compared studies in both cohorts with and without diabetes. In general, there is a consensus that BP in the range below a systolic of 130 mmHg is associated with fewer CVD events in diabetes compared to levels below 140 mmHg (Emdin et al. 2015; Perkovic and Rodgers 2015; Xie et al. 2016). Hence, in the first quarter 2016 update of UpToDate, we expanded our evidence-based approach to guideline BP ranges based on confidence intervals from trials that evaluated CVD outcomes and concluded that a systolic range of 125–130 mmHg is appropriate for people who can tolerate it to achieve maximal CVD risk reduction from BP. Please note that people with diastolic BP below 60 were not included in any of these trials. Thus, in those with large pulse pressures the reduction in systolic BP (SBP) should also be guided by the magnitude of diastolic pressure reduction such that levels in patients without angina do not fall below 60 mmHg, as this has been associated with higher CV risk as well as a higher incidence of progression to dialysis among nephropathy patients (Peralta et al. 2012; Bangalore et al. 2010; Kjeldsen et al. 2016).

A substantial amount of epidemiological and post hoc analyses clinical trial data supports the notion that the presence of diabetic nephropathy manifested by proteinuria above 300 mg/day is associated with higher cardiovascular event rates (Ibsen et al. 2004; So et al. 2006). Moreover, all studies among patients with diabetes indicate that proteinuria reduction of >30% within the first 6–12 months of BP-lowering therapy reduces cardiovascular events and development of heart failure as well as slows kidney disease progression (Berl et al. 2005; de Zeeuw et al. 2004). Taken together, this data supports the notion that treatment of blood pressure in people with diabetes must focus not only on achievement of BP goal but also reducing proteinuria, if present. This recommendation is also consistent with the Kidney Disease Improving Global Outcomes (KDIGO) guidelines to achieve a BP <130/80 mmHg in such patients. Thus, as suggested by guidelines, all patients with diabetes should be evaluated for albuminuria at least once annually (National Kidney Foundation 2007). Antihypertensive agents found to maximally reduce proteinuria when blood pressure is reduced include blockers of the renin-angiotensin-aldosterone system (RAAS) either alone or combined along with nondihydropyridine calcium channel blockers (CCBs) (National Kidney Foundation 2007; Sarafidis et al. 2007a).

---

## Effect of Antihypertensive Agents on Diabetes

The different medications used in the treatment of hypertension can have variable metabolic effects. This should be considered when prescribing and monitoring diabetic patients. Since the publication of JNC 7, several important observations regarding BP management and glycemic control in patients with diabetes are now apparent. First, post hoc analyses of two different cardiovascular outcome trials note that even though diuretics worsen glycemic control, cardiovascular event rates were

not higher (Kostis et al. 2005; Whelton et al. 2005). Specifically, a post hoc analysis of the Systolic Hypertension in the Elderly Program (SHEP) notes that worsening of glycemic control with diuretics did not result in a reduced long-term benefit of thiazide-type diuretic (chlorthalidone) induced lowering of systolic pressures on cardiovascular risk (Kostis et al. 2005). Additionally, an analysis of the Antihypertensive and Lipid-Lowering Treatment to Prevent Heart Attack Trial (ALLHAT) subgroup with diabetes failed to show a higher cardiovascular event rate in the diuretic group even though they had the greatest worsening of glycemic control (Whelton et al. 2005).

While these trials do not answer the question fully as these were post hoc analyses and patients followed only over a limited period of time, a more recent study with over a decade of follow-up from the ALLHAT demonstrates that those randomized to chlorthalidone who developed diabetes and were treated had similar CVD outcomes to those who did not develop diabetes (Barzilay et al. 2012). Further, the impacts of drug-induced increases in diabetes incidence on microvascular diseases such as retinopathy and nephropathy, although not systemically studied, are likely substantial.

Many post hoc analyses, however, uniformly demonstrate that diuretics and  $\beta$ -blockers not only worsen glycemic status among those with diabetes but also increase development of new onset diabetes in those with impaired fasting glucose (Elliott and Meyer 2007; Mancia et al. 2006; Sarafidis and Bakris 2006a). Hence, they increase the number of medications taken and need for more frequent physician visits. Both thiazide and thiazide-like diuretics, through hypokalemia and other mechanisms related to increased visceral adiposity (Carter et al. 2008), and vasoconstricting  $\beta$ -blockers worsen insulin sensitivity (Sarafidis et al. 2007b); exceptions to this statement include the newer vasodilating  $\beta$ -blockers, such as carvedilol and nebivolol. These vasodilating agents have neutral effects on glycemic control and increase insulin sensitivity (Bakris et al. 2004; Kaiser et al. 2006; Sarafidis and Bakris 2006b).

Angiotensin-converting enzyme (ACE) inhibitors, angiotensin II receptor blockers (ARBs), and calcium channel blockers (CCBs) have beneficial or neutral effects on insulin sensitivity and glycemic control (Sarafidis and Bakris 2006a; Sarafidis et al. 2007b; DREAM Trial Investigators et al. 2006). Note also that renin-angiotensin system (RAS) blockers administered concomitantly with thiazide diuretics do not prevent worsening of glycemic control in obese people with impaired fasting glucose (Bakris et al. 2006). These data, taken together with the findings of a meta-analysis by the blood pressure trialists (Blood Pressure Lowering Treatment Trialists Collaboration et al. 2008), indicate that since it is BP lowering and not the class of antihypertensive agent used that reduces cardiovascular events, one should use antihypertensive agents that do not worsen preexisting metabolic conditions.

---

## Approach to Treatment

To achieve a blood pressure goal, the cornerstone of therapy is lifestyle modification with a focus on reduced sodium intake and good sleep hygiene of at least 6 h of uninterrupted sleep a night (Hwang et al. 2015; Liu et al. 2016). Additional lifestyle

changes include weight loss, increase in physical exercise, reduction of alcohol intake, smoking cessation, and, perhaps most importantly, low sodium intake to levels below 2.4 g per day. Low salt intake should be encouraged through appropriate dietary counseling and encouragement by the physician and staff (Table 2). The differential effects of sodium restriction in different patient groups are, in part, related to their RAAS activity, the lower the renin state the less likely a low sodium diet will help lower pressure (He et al. 2001).

A high potassium diet in those who have an estimated glomerular filtration rate (eGFR) above 45 mL/min/1.73 m<sup>2</sup> can help counteract the blood pressure raising effects of high salt intake (Sebastian et al. 1999). Failure to achieve a serum potassium level of at least 3.8 mEq/L will also blunt the antihypertensive activity of agents due to sustained vasoconstriction at low levels of potassium (Adrogué and Madias 2007). In addition to diet changes, patients should be educated on the importance of maintaining weight range that is below the obesity level and ideally closer to BMI <26 kg/m<sup>2</sup> (Appel et al. 2006). Most clinical trials support the notion that weight loss results in blood pressure reduction (Neter et al. 2003; Stevens et al. 2001; Knowler et al. 2002).

Additionally, the American Diabetes Association guidelines should also be followed to optimize glycemic control (Standards of Medical Care in Diabetes-2016). This is important especially for morbidity reduction, i.e., reduction of neuropathy and blindness. While mortality reduction is associated with good glycemic control, the level to which glucose needs reduction appears to be higher than previously thought.

The ACCORD trial that tested whether a lower level of glucose, defined as a HbA1c <6.5%, would result in a lower cardiovascular event rate was stopped early by the Data Safety Monitoring Board secondary to a higher cardiovascular event rate in the lower glucose control group (Action to Control Cardiovascular Risk in Diabetes Study Group et al. 2008). Similarly, the advance trial did not show any improvement in cardiovascular outcome with aggressive treatment of HbA1c to less than 6.5% (Advance Collaborative Group et al. 2008). This study did show a 20% reduction in new onset nephropathy with aggressive glycemic treatment, however.

**Table 2** Lifestyle modifications to prevent and manage hypertension<sup>a</sup>

<b>Weight reduction</b>	Maintain normal body weight (body mass index 18.5–24.9 kg/m <sup>2</sup> )
<b>Adopt DASH eating plan</b>	Consume a diet rich in fruits, vegetables, and low-fat dairy products with a reduced content of saturated and total fat
<b>Dietary sodium reduction</b>	Reduce dietary sodium intake to no more than 100 mmol per day (2.4 g sodium or 6 g sodium chloride)
<b>Physical activity</b>	Engage in regular aerobic physical activity such as brisk walking (at least 30 min per day, most days of the week)
<b>Moderate alcohol use</b>	Limit consumption to no more than 2 drinks (e.g., 24 oz. beer, 10 oz. wine, or 3 oz. 80-proof whiskey) per day in most men and to no more than 1 drink per day in women and lighter weight persons

*DASH* dietary approaches to stop hypertension

<sup>a</sup>Adapted from the seventh report of the Joint National Committee on Prevention, Detection, Evaluation, and Treatment of High Blood Pressure (Chobanian et al. 2003)

As a result of these data, the American Diabetes Association guideline recommends a HbA1c of <7% to provide the greatest cardiovascular risk reduction when coupled with BP reduction.

In addition to the lifestyle measures, all patients with diabetes with a sustained BP  $\geq$  140/90 mmHg should be started on antihypertensive medication. It is critically important to reduce BP to levels well below 140/90 mmHg regardless of medication class. Current guidelines recommend initial treatment with an angiotensin-converting enzyme inhibitor (ACEI), angiotensin receptor blocker (ARB), calcium channel blocker (CCB), or thiazide-like diuretic. If, within a month after monotherapy titration, the BP goal is not achieved, then either a CCB, e.g., amlodipine, or a low-dose thiazide-like diuretic like 1.25 mg of indapamide or 12.5 mg chlorthalidone (found only in combination with the ARB, azilsartan) may be tried. Note that the CCB/ACE inhibitor combination was found to provide significantly greater reduction in CV events in people with diabetes compared to an ACE inhibitor diuretic combination (Weber et al. 2010, 2013). Additionally, chlorthalidone and indapamide are effective for BP lowering down to an eGFR of 30 mL/min/1.73 m<sup>2</sup> (Agarwal et al. 2014). In the case of a patient with an estimated glomerular filtration rate (eGFR) <30 mL/min/1.73 m<sup>2</sup>, the thiazide-like diuretic should be replaced by a long-acting loop diuretic in adequate doses, e.g., once daily torsemide starting at 5 or 10 mg daily.

If the initial blood pressure is more than 20/10 mmHg above goal, then *two agents* with complementary mechanisms should be started (Gradman et al. 2010). Blood pressure should be monitored every week at home and a return to the office with those readings in 1 month. If blood pressure remains elevated on *two agents*, then consider either titrating or adding a third agent, Fig. 1. The 4th antihypertensive medication recommended is a mineralocorticoid antagonist or if not tolerated or risk of hyperkalemia, a vasodilating  $\beta$ -blocker such as carvedilol or nebivolol, which has a better tolerability profile and less metabolic consequences and little to no weight gain compared to older agents (Action to Control Cardiovascular Risk in Diabetes Study Group et al. 2008; Advance Collaborative Group et al. 2008).

In patients with asthma, diltiazem or in some cases verapamil are very good alternative (Weber et al. 2010). Other alternative 4th or 5th-line agents include an aldosterone receptor blocker or a CCB from a different subclass than is already being used, e.g., diltiazem added to amlodipine. Two randomized trials clearly showed additive BP lowering effects when low doses of these two subclasses are combined (Gradman et al. 2010; Saseen et al. 1996). Since no difference in cardiovascular outcomes has been noted between antihypertensive agents if BP is appropriately lowered, this approach mitigates against worsening of metabolic control and is in concert with both the Expert Panel Report and the 2013 European Guidelines (James et al. 2014; Mancia et al. 2007b).

Recent data do *not* support older concepts that high albuminuria (formerly microalbuminuria) is synonymous with kidney disease. However, high albuminuria is a CVD risk marker in some cases as good as C-reactive protein (Bakris and Molitch 2014). Thus, routine annual measurement of albuminuria is important as it is

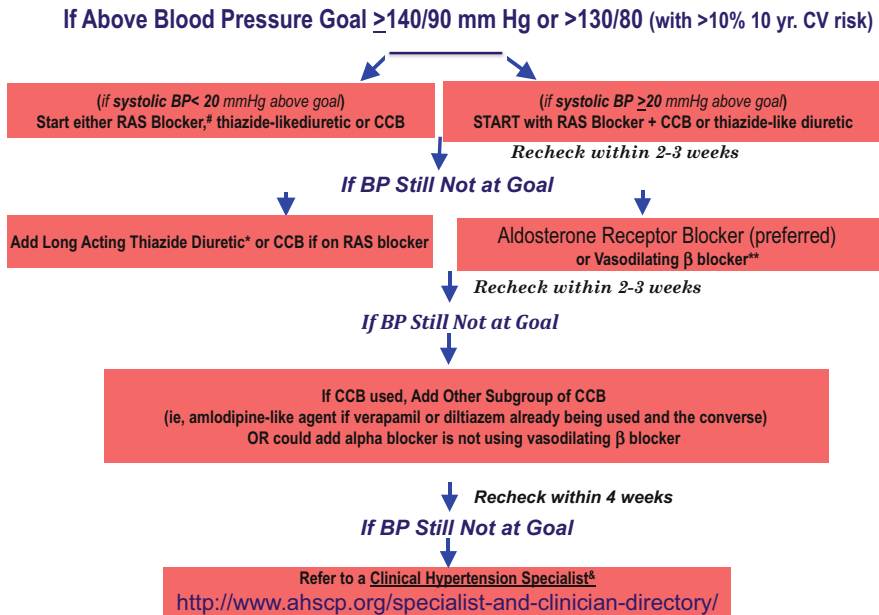

**Fig. 1** American Society of Hypertension Algorithm for BP management in diabetes. \*Thiazide-type diuretic is chlorthalidone or indapamide; \*\*refers to either carvedilol or nebivolol. (Note: Ratio of beta:alpha is 7:1 for labetalol and 3:1 for carvedilol, hence, carvedilol is more balanced). <sup>#</sup>Must start with ACE inhibitor or angiotensin receptor blocker (ARB) collectively known as renin-angiotensin system (RAS) blockers if  $>300$  mg/day albuminuria. <sup>&</sup>Website for hypertension specialists <http://www.ahsccp.org/specialist-and-clinician-directory/> (Bakris and Sowers 2008; de Boer et al. 2017)

a CV risk marker and indicates inflammation but also a rise into the very high albuminuria range, i.e.,  $>300$  mg/day, indicates nephropathy (Bakris and Molitch 2014). Nevertheless, most guidelines prefer a once daily RAS blocker with dose maximized within the first month as an initial antihypertensive as it is relatively low on side effects and efficacies. Whether choosing an ACE inhibitor or an ARB, dosage should be titrated to the highest tolerated dose necessary for BP to reach the goal.

The Food and Drug Administration issued a guidance in 2011 that all ARBs should be started at the maximal dose since they have no dose-dependent side effects. If an ACE inhibitor is started and the side effect of cough appears, treatment should be changed to an appropriate dose of an ARB. Note the mean incidence of cough from ACE inhibitors is 20% and more than double that in the Asian population.

RAS blockers have demonstrated positive effects on the development of metabolic conditions. A study of 53 premenopausal females that were treated with RAS blockade or placebo found higher levels of plasma adiponectin in subjects treated with RAS blockade. Adiponectin is an adipokine that has beneficial effects in

obesity-associated conditions (Flynn and Bakris 2011). This study also found that the insulin sensitivity of subcutaneous and omental adipocytes was better in the RAS blockade-treated subjects (Tian et al. 2010).

A common problem among people with diabetes and kidney disease with RAAS blockers is hyperkalemia. People most prone to develop hyperkalemia include everyone regardless of diabetes status with an eGFR  $<45$  mL/min/1.73 m<sup>2</sup> and/or a serum potassium of  $>4.5$  mEq/L already receiving an appropriately dosed diuretic (Lazich and Bakris 2014). There is no substitute or guide for good clinical judgment, however, for any given patient. Therefore, in anyone meeting these criteria it is important before initiating RAS-blocking therapy to review all high potassium-containing foods and substances as well as over-the-counter agents that cause hyperkalemia such as NSAIDs. Observational data support reductions of up to 0.6 mEq/L in serum potassium can be achieved just by following these lifestyle interventions. Under a circumstance when potassium levels are elevated, use of loop diuretics may be appropriate twice daily to enable use of RAS-blocking agents or use of the newly approved potassium-binding agents, patiomer or ZS-9. Both of these potassium binders are far better tolerated than sodium polystyrene and are once daily preparations (Bakris et al. 2015; Kosiborod et al. 2014).

While there are no cardiovascular outcome data in patients with relatively high potassium levels, post hoc analyses that primarily evaluated kidney disease progression among those with GFR values of  $<50$  mL/min show a reduction in cardiovascular events and surrogate risk factors for CV risk among those with diabetes (Berl et al. 2005; Lewis et al. 2001).

Minimization of the number of antihypertensive pills improves patient adherence and effectiveness of lowering BP (Gerbino and Shoheiber 2007; Bangalore et al. 2007). Thus, conversion of the full combination treatment to a single pill combination of RAS blocker/diuretic or RAS blocker/CCB should be given strong consideration. Combinations of an ACE inhibitor and ARB while further reducing proteinuria (Knowler et al. 2002) are contraindicated for BP lowering in patients with diabetic nephropathy (Mann et al. 2008; Parving et al. 2012) as they did not reduce mortality and increased risk of acute kidney injury (Stevens et al. 2001). The American Society of Hypertension Consensus report of Combination Therapies is summarized in Table 3.

The role of aldosterone blockade as a fourth line strategy is very important in patients with diabetes and obesity. Individuals with obstructive sleep apnea and central obesity have demonstrated major benefits in BP reduction with the use of aldosterone antagonist (Pratt-Ubunama et al. 2007; Calhoun et al. 2008). In a study of 76 patients with uncontrolled BP on an average of four medications, including an ACE inhibitor or ARB and a thiazide diuretic, addition of spironolactone (12.5–25 mg daily) resulted in an average 25 mmHg reduction of SBP and 12 for DBP after 6 months of follow-up (Nishizaka et al. 2003). Reductions in BP were similar in African American and Caucasian individuals. Moreover, the BP lowering response was not predicted by baseline plasma aldosterone, 24-h urinary aldosterone, plasma renin activity, or plasma aldosterone/renin ratio.

**Table 3** Evidenced-based fixed-dose antihypertensive combinations

Preferred
• ACE inhibitor/diuretic <sup>a</sup>
• ARB/diuretic <sup>a</sup>
• ACE inhibitor/CCB <sup>a</sup>
• ARB/CCB <sup>a</sup>
Acceptable
• $\beta$ -blocker/diuretic <sup>a</sup>
• CCB (dihydropyridine)/ $\beta$ -blocker
• CCB/diuretic
• Renin inhibitor/diuretic <sup>a</sup>
• Renin inhibitor/ARB <sup>a</sup>
• Thiazide diuretics/K <sup>+</sup> -sparing diuretics <sup>a</sup>
Less effective
• ACE inhibitor/ARB
• ACE inhibitor/ $\beta$ -blocker
• ARB/ $\beta$ -blocker
• CCB (nondihydropyridine)/ $\beta$ -blocker
• Centrally acting agent/ $\beta$ -blocker

Note: Less effective combinations do not further lower BP and can create dangerous situations with very low heart rates or increased risk for acute kidney injury

<sup>a</sup>Indicates single pill combinations

The BP-lowering effects of aldosterone receptor blockade were confirmed in a report of 1411 participants in the Anglo-Scandinavian Cardiac Outcomes Trial (ASCOT)-Blood Pressure Lowering Arm, unselected for plasma aldosterone and plasma renin activity. They received spironolactone mainly as a fourth-line antihypertensive agent for uncontrolled BP on an average of three drugs (Chapman et al. 2007). Use of spironolactone was again associated with a BP drop of 21.9/9.5 mmHg, which was largely unaffected by factors like age, sex, smoking, and diabetic status. Recent data in obese patients demonstrates that the adipocyte releases substances that increase aldosterone and this may be the reason for this observation (Krug and Ehrhart-Bornstein 2008). Given the benefits of aldosterone blockade in these individuals and those with sleep apnea, one is reminded of hyperkalemia as a limiting factor in their use (Pratt-Ubunama et al. 2007; Chapman et al. 2007). The reader is referred to this chapter's discussion of treatment approaches for BP for more details on this topic.

The sodium-dependent glucose cotransporters (SGLT2) inhibitors are a relatively new class of agents used to control blood sugar in diabetes mellitus and they also have the added benefit of blood pressure lowering. The SGLT2 transporter mediates glucose reabsorption in the proximal tubule and it regulates 90% of all glucose reabsorption by the kidney (Scheen 2015a). The SGLT2 inhibitors act by competitive and selective inhibition of the SGLT2 transporter. Patients with type 2 diabetes mellitus overexpress SGLT2 receptors, a compensatory mechanism to try and remove more glucose through the urine. Use of these medications decreases the renal glucose threshold leading to an increase in urinary glucose excretion. The



glycosuric effect also leads to some weight loss and a reduction in blood pressure, due to the mild natriuretic and osmotic diuretic effects.

The average BP reduction with these agents is 4–5 mmHg systolic pressure and the newer combined SGLT2/SGLT1 inhibitor averages almost double in this BP reduction. The mechanism for BP reduction is unknown but probably multifactorial and is reviewed elsewhere (Oliva and Bakris 2014).

These medications have been used safely in patients with Stage 3 (estimated glomerular filtration rates (eGFR) down to 30 mL/min) chronic kidney disease (CKD). However, the glycemic reduction response to the SGLT2 inhibitors declines with decreasing kidney function because a decrease in eGFR results in a decrease in urinary glucose excretion (Scheen 2015b). The Food and Drug Administration (FDA) has approved canagliflozin and empagliflozin for use down to eGFR of 45 mL/min/1.73 m<sup>2</sup>, whereas dapagliflozin is approved down to 60 mL/min/1.73 m<sup>2</sup>. Studies with canagliflozin show clear benefit on BP and eGFR down to eGFR of 30 mL/min/1.73 m<sup>2</sup> (Yamout et al. 2014).

Due to this reduced glycemic control based on level of kidney function, further studies have attempted to determine the renal effects of SGLT2 inhibitors. Ojima et al. treated streptozocin-induced diabetic rats with the SGLT2 inhibitor empagliflozin for 4 weeks. In addition to improving blood glucose levels, the rats treated with empagliflozin had decreased levels of markers of oxidative stress in the diabetic kidney. Specifically, levels of advanced glycation end products (AGE) and receptor advanced glycation end products (RAGE) were significantly lowered (Ojima et al. 2015).

Hyperfiltration is considered an early marker of risk for diabetic nephropathy and is associated with abnormally high plasma glucose levels (Jerums et al. 2010). Experimental animal models using phlorizin, a nonspecific inhibitor of SGLT1 and SGLT2, demonstrate a restoration of tubuloglomerular feedback that is altered in renal hyperfiltration (Malatiali et al. 2008). Due to the poor tolerability of phlorizin in humans, the effects of this drug on renal hyperfiltration are not known. Now that the more specific SGLT2 inhibitors are available, Cherney et al. investigated the effects of empagliflozin 25 mg daily on renal hyperfiltration in patients with type 1 diabetes mellitus (Cherney et al. 2014). Forty subjects completed the study, 13 with normal filtering kidneys and 27 with renal hyperfiltration. The subjects were treated with empagliflozin for 8 weeks. In the subjects with renal hyperfiltration, treatment with empagliflozin for 8 weeks resulted in a significant reduction in hyperfiltration during both clamped euglycemic and hyperglycemic conditions (Cherney et al. 2014).

Changes in tubuloglomerular feedback examined by Cherney et al. relate to the natriuretic effects of the SGLT2 agents and wane over time as a new level of glucose homeostasis is achieved. Another factor important in assessing volume status in diabetes that is affected in animal models of diabetes is atrial natriuretic peptide (ANP) (Ortola et al. 1987). Diabetes is a volume-expanded state for many reasons and hence, a compensatory increase in ANP is well documented. ANP results in suppression of the renin-angiotensin system and contributes to hyperfiltration. Animal studies demonstrate that phlorizin through its osmotic diuretic and natriuretic effects reduces ANP and reestablishes a new volume status in animals over

2–3 days (Thomson et al. 2012). This improvement in volume also contributes to reductions in blood pressure (Oliva and Bakris 2014; Baker et al. 2014).

A dual SGLT1 and SGLT2 inhibitor, sotagliflozin, is another emerging therapy for treating patients with diabetes mellitus. SGLT1 is the major transporter for the absorption of glucose and galactose in the intestine (Wright et al. 2011). SGLT1 knockout mice have demonstrated a dramatic reduction in postprandial glucose. Also, these knockout mice had an increase in glucagon-like peptide 1 (GLP-1) by L-cells which is involved in glucose control (Powell et al. 2013). Inhibiting SGLT1 has also been demonstrated to stimulate the release of polypeptide tyrosine tyrosine (PYY), which is involved in appetite control (Powell et al. 2013). These knockout mice had watery or unformed stools when fed a diet of glucose or galactose. However, mice with a partial knockout of SGLT1 had normal stools when fed glucose but still maintained an increase in glucose load to the distal small intestine with a rise in GLP-1 (Powell et al. 2013). These animal studies suggest the dual SGLT1/SGLT2 inhibitor may provide even more powerful reductions in glucose and weight as well as blood pressure in patients with type 2 diabetes.

In order to investigate the effects of sotagliflozin in patients with renal impairment, 31 patients with type 2 diabetes mellitus and a GFR of 15–59 mL/min/1.73 m<sup>2</sup> were randomly assigned to sotagliflozin or placebo. There was a significant reduction in postprandial glucose on day 7 in the sotagliflozin compared to placebo group. Of those patients with a GFR <45 mL/min/1.73 m<sup>2</sup>, the magnitude of the effect on postprandial glucose was maintained. There was also a significant reduction in systolic blood pressure in the treatment group compared to placebo after 7 days (Zambrowicz et al. 2015). These studies show promising results of a new agent to use in the management of patients with diabetes.

In cardiovascular outcome trials among patients with hypertension, the proportion of participants achieving BP goals is roughly double that of clinical practice. An assessment of the subgroup with diabetes in these outcome trials over the past decade indicates that an average of 2.9 appropriately dosed antihypertensive medications are required to achieve BP goals. Among persons with diabetes and preexisting kidney disease, Stage 3 or higher, this average increases to about 3.5 medications (Chua and Bakris 2004). Thus, a key tenet in the approach to achieve BP goal in patients with diabetes is to select agents for maximal efficacy and tolerability that have the fewest side effects and, if possible, cost.

---

## Summary

Patients with diabetes and hypertension have an increased risk of cardiovascular disease and death from cardiovascular disease. It is important to treat both the elevated blood sugars and elevated blood pressure in these patients. The agents used to treat the hypertensive patient with diabetes are important to both lower blood pressure and improve kidney outcomes, and to use agents that do not adversely affect metabolic outcomes.

Use of antihypertensive agents as well as glycemic control and lipid control are critical in these patients to maximally reduce cardiovascular events. Only the SGLT2 inhibitors have thus far shown CVD risk reduction and many other new classes or glucose-lowering agents have proven no harm on CVD events. Moreover, BP lowering and lipid control show the greatest benefit in the shortest time, i.e., 3–5 years in regard to reducing CVD risk and slowing of CKD progression. Glycemic control takes an average of 10–12 years to see benefits on CVD risk and CKD progression. Lastly, there is no “legacy effect” of BP control on CVD events but it does exist for glycemic and lipid control.

---

## References

- Accord Study Group, Cushman WC, Evans GW, Byington RP, Goff DC Jr, Grimm RH Jr, et al. Effects of intensive blood-pressure control in type 2 diabetes mellitus. *N Engl J Med.* 2010;362(17):1575–85.
- Action to Control Cardiovascular Risk in Diabetes Study Group, Gerstein HC, Miller ME, Byington RP, Goff DC Jr, Bigger JT, et al. Effects of intensive glucose lowering in type 2 diabetes. *N Engl J Med.* 2008;358(24):2545–59.
- Adroge HJ, Madias NE. Sodium and potassium in the pathogenesis of hypertension. *N Engl J Med.* 2007;356(19):1966–78.
- Advance Collaborative Group, Patel A, MacMahon S, Chalmers J, Neal B, Billot L, et al. Intensive blood glucose control and vascular outcomes in patients with type 2 diabetes. *N Engl J Med.* 2008;358(24):2560–72.
- Agarwal R, Sinha AD, Pappas MK, Ammous F. Chlorthalidone for poorly controlled hypertension in chronic kidney disease: an interventional pilot study. *Am J Nephrol.* 2014;39(2):171–82.
- Appel LJ, Brands MW, Daniels SR, Karanja N, Elmer PJ, Sacks FM, et al. Dietary approaches to prevent and treat hypertension: a scientific statement from the American Heart Association. *Hypertension.* 2006;47(2):296–308.
- Baker WL, Smyth LR, Riche DM, Bourret EM, Chamberlin KW, White WB. Effects of sodium-glucose co-transporter 2 inhibitors on blood pressure: a systematic review and meta-analysis. *J Am Soc Hypertens.* 2014;8(4):262–75 e9.
- Bakris GL. The importance of blood pressure control in the patient with diabetes. *Am J Med.* 2004;116(Suppl 5A):30S–8S.
- Bakris GL, Molitch M. Microalbuminuria as a risk predictor in diabetes: the continuing saga. *Diabetes Care.* 2014;37(3):867–75.
- Bakris GL, Sowers JR. ASH position paper: treatment of hypertension in patients with diabetes—an update. *J Clin Hypertens (Greenwich).* 2008;10:707–13.
- Bakris GL, Fonseca V, Katholi RE, McGill JB, Messerli FH, Phillips RA, et al. Metabolic effects of carvedilol vs metoprolol in patients with type 2 diabetes mellitus and hypertension: a randomized controlled trial. *JAMA.* 2004;292(18):2227–36.
- Bakris G, Molitch M, Hewkin A, Kipnes M, Sarafidis P, Fakouhi K, et al. Differences in glucose tolerance between fixed-dose antihypertensive drug combinations in people with metabolic syndrome. *Diabetes Care.* 2006;29(12):2592–7.
- Bakris GL, Pitt B, Weir MR, Freeman MW, Mayo MR, Garza D, et al. Effect of Patiromer on serum potassium level in patients with hyperkalemia and diabetic kidney disease: the AMETHYST-DN randomized clinical trial. *JAMA.* 2015;314(2):151–61.
- Bangalore S, Kamalakkannan G, Parkar S, Messerli FH. Fixed-dose combinations improve medication compliance: a meta-analysis. *Am J Med.* 2007;120(8):713–9.
- Bangalore S, Messerli FH, Wun CC, Zuckerman AL, DeMicco D, Kostis JB, et al. J-curve revisited: an analysis of blood pressure and cardiovascular events in the treating to new targets (TNT) trial. *Eur Heart J.* 2010;31(23):2897–908.

- Barzilay JI, Davis BR, Pressel SL, Cutler JA, Einhorn PT, Black HR, et al. Long-term effects of incident diabetes mellitus on cardiovascular outcomes in people treated for hypertension: the ALLHAT diabetes extension study. *Circ Cardiovasc Qual Outcomes*. 2012;5(2):153–62.
- Becton LJ, Shatat IF, Flynn JT. Hypertension and obesity: epidemiology, mechanisms and clinical approach. *Indian J Pediatr*. 2012;79(8):1056–61.
- Bengtsson K, Orho-Melander M, Lindblad U, Melander O, Bog-Hansen E, Ranstam J, et al. Polymorphism in the angiotensin converting enzyme but not in the angiotensinogen gene is associated with hypertension and type 2 diabetes: the Skaraborg hypertension and diabetes project. *J Hypertens*. 1999;17(11):1569–75.
- Berl T, Hunsicker LG, Lewis JB, Pfeffer MA, Porush JG, Rouleau JL, et al. Impact of achieved blood pressure on cardiovascular outcomes in the Irbesartan diabetic nephropathy trial. *J Am Soc Nephrol*. 2005;16(7):2170–9.
- Blood Pressure Lowering Treatment Trialists Collaboration, Turnbull F, Neal B, Ninomiya T, Algert C, Arima H, et al. Effects of different regimens to lower blood pressure on major cardiovascular events in older and younger adults: meta-analysis of randomised trials. *BMJ*. 2008;336(7653):1121–3.
- Buraczynska M, Zukowski P, Buraczynska K, Mozul S, Ksiazek A. Renalase gene polymorphisms in patients with type 2 diabetes, hypertension and stroke. *NeuroMolecular Med*. 2011;13(4):321–7.
- Buse JB, Ginsberg HN, Bakris GL, Clark NG, Costa F, Eckel R, et al. Primary prevention of cardiovascular diseases in people with diabetes mellitus: a scientific statement from the American Heart Association and the American Diabetes Association. *Circulation*. 2007;115(1):114–26.
- Calhoun DA, Jones D, Textor S, Goff DC, Murphy TP, Toto RD, et al. Resistant hypertension: diagnosis, evaluation, and treatment. A scientific statement from the American Heart Association professional education Committee of the Council for high blood pressure research. *Hypertension*. 2008;51(6):1403–19.
- Carter BL, Einhorn PT, Brands M, He J, Cutler JA, Whelton PK, et al. Thiazide-induced dysglycemia: call for research from a working group from the national heart, lung, and blood institute. *Hypertension*. 2008;52(1):30–6.
- Chapman N, Dobson J, Wilson S, Dahlof B, Sever PS, Wedel H, et al. Effect of spironolactone on blood pressure in subjects with resistant hypertension. *Hypertension*. 2007;49(4):839–45.
- Cherney DZ, Perkins BA, Soleymanlou N, Maione M, Lai V, Lee A, et al. Renal hemodynamic effect of sodium-glucose cotransporter 2 inhibition in patients with type 1 diabetes mellitus. *Circulation*. 2014 Feb 4;129(5):587–97.
- Chobanian AV, Bakris GL, Black HR, Cushman WC, Green LA, Izzo JL Jr, et al. Seventh report of the joint national committee on prevention, detection, evaluation, and treatment of high blood pressure. *Hypertension*. 2003;42(6):1206–52.
- Chua DC, Bakris GL. Is proteinuria a plausible target of therapy? *Curr Hypertens Rep*. 2004;6(3):177–81.
- Cooper-DeHoff RM, Gong Y, Handberg EM, Bavry AA, Denardo SJ, Bakris GL, et al. Tight blood pressure control and cardiovascular outcomes among hypertensive patients with diabetes and coronary artery disease. *JAMA*. 2010;304(1):61–8.
- de Boer IH, Bangalore S, Benetos A, Davis AM, Michos ED, Muntner P, Rossing P, Zoungas S, Bakris G. Diabetes and hypertension: a position statement by the American Diabetes Association. *Diabetes Care*. 2017;40(9):1273–84.
- de Zeeuw D, Remuzzi G, Parving HH, Keane WF, Zhang Z, Shahinfar S, et al. Albuminuria, a therapeutic target for cardiovascular protection in type 2 diabetic patients with nephropathy. *Circulation*. 2004;110(8):921–7.
- DREAM Trial Investigators, Bosch J, Yusuf S, Gerstein HC, Pogue J, Sheridan P, et al. Effect of ramipril on the incidence of diabetes. *N Engl J Med*. 2006;355(15):1551–62.
- Egan BM, Zhao Y, Axon RN. US trends in prevalence, awareness, treatment, and control of hypertension, 1988–2008. *JAMA*. 2010;303(20):2043–50.
- Elliott WJ, Meyer PM. Incident diabetes in clinical trials of antihypertensive drugs: a network meta-analysis. *Lancet*. 2007;369(9557):201–7.

- Emdin CA, Rahimi K, Neal B, Callender T, Perkovic V, Patel A. Blood pressure lowering in type 2 diabetes: a systematic review and meta-analysis. *JAMA*. 2015;313(6):603–15.
- Engeli S, Bohnke J, Gorzelniak K, Janke J, Schling P, Bader M, et al. Weight loss and the renin-angiotensin-aldosterone system. *Hypertension*. 2005;45(3):356–62.
- Estacio RO, Jeffers BW, Gifford N, Schrier RW. Effect of blood pressure control on diabetic microvascular complications in patients with hypertension and type 2 diabetes. *Diabetes Care*. 2000;23(Suppl 2):B54–64.
- Flynn C, Bakris GL. Interaction between adiponectin and aldosterone. *Cardiorenal Med*. 2011;1(2):96–101.
- Gerbino PP, Shoheiber O. Adherence patterns among patients treated with fixed-dose combination versus separate antihypertensive agents. *Am J Health Syst Pharm*. 2007;64(12):1279–83.
- Giles TD, Materson BJ, Cohn JN, Kostis JB. Definition and classification of hypertension: an update. *J Clin Hypertens*. 2009;11(11):611–4.
- Goodfriend TL, Calhoun DA. Resistant hypertension, obesity, sleep apnea, and aldosterone: theory and therapy. *Hypertension*. 2004;43(3):518–24.
- Gorzelniak K, Engeli S, Janke J, Luft FC, Sharma AM. Hormonal regulation of the human adipose-tissue renin-angiotensin system: relationship to obesity and hypertension. *J Hypertens*. 2002;20(5):965–73.
- Gradman AH, Basile JN, Carter BL, Bakris GL, Materson BJ, Black HR, et al. Combination therapy in hypertension. *J Am Soc Hypertens*. 2010;4(2):90–8.
- Groop LC, Kankuri M, Schalin-Jantti C, Ekstrand A, Nikula-Ijas P, Widen E, et al. Association between polymorphism of the glycogen synthase gene and non-insulin-dependent diabetes mellitus. *N Engl J Med*. 1993;328(1):10–4.
- Hajjar I, Kotchen TA. Trends in prevalence, awareness, treatment, and control of hypertension in the United States, 1988-2000. *JAMA*. 2003;290(2):199–206.
- Hall JE. The kidney, hypertension, and obesity. *Hypertension*. 2003;41(3 Pt 2):625–33.
- Hansson L, Zanchetti A, Carruthers SG, Dahlof B, Elmfeldt D, Julius S, et al. Effects of intensive blood-pressure lowering and low-dose aspirin in patients with hypertension: principal results of the hypertension optimal treatment (HOT) randomised trial. HOT study group. *Lancet*. 1998;351(9118):1755–62.
- He FJ, Markandu ND, MacGregor GA. Importance of the renin system for determining blood pressure fall with acute salt restriction in hypertensive and normotensive whites. *Hypertension*. 2001;38(3):321–5.
- Hwang HR, Lee JG, Lee S, Cha KS, Choi JH, Jeong DW, et al. The relationship between hypertension and sleep duration: an analysis of the fifth Korea National Health and nutrition examination survey (KNHANES V-3). *Clinical Hypertens*. 2015;21:8.
- Hypertension in Diabetes Study Group. Hypertension in diabetes study (HDS): I. Prevalence of hypertension in newly presenting type 2 diabetic patients and the association with risk factors for cardiovascular and diabetic complications. *J Hypertens*. 1993;11(3):309–17.
- Ibsen H, Wachtell K, Olsen MH, Borch-Johnsen K, Lindholm LH, Mogensen CE, et al. Does albuminuria predict cardiovascular outcome on treatment with losartan versus atenolol in hypertension with left ventricular hypertrophy? A LIFE substudy. *J Hypertens*. 2004;22(9):1805–11.
- International Consortium for Blood Pressure Genome-Wide Association Studies, Ehret GB, Munroe PB, Rice KM, Bochud M, Johnson AD, et al. Genetic variants in novel pathways influence blood pressure and cardiovascular disease risk. *Nature*. 2011;478(7367):103–9.
- James PA, Oparil S, Carter BL, Cushman WC, Dennison-Himmelfarb C, Handler J, et al. 2014 evidence-based guideline for the management of high blood pressure in adults: report from the panel members appointed to the eighth joint National Committee (JNC 8). *JAMA*. 2014;311(5):507–20.
- Jerums G, Premaratne E, Panagiotopoulos S, MacIsaac RJ. The clinical significance of hyperfiltration in diabetes. *Diabetologia*. 2010 Oct;53(10):2093–104.

- Kadowaki T, Kadowaki H, Rechler MM, Serrano-Rios M, Roth J, Gorden P, et al. Five mutant alleles of the insulin receptor gene in patients with genetic forms of insulin resistance. *J Clin Invest.* 1990;86(1):254–64.
- Kaiser T, Heise T, Nosek L, Eckers U, Sawicki PT. Influence of nebivolol and enalapril on metabolic parameters and arterial stiffness in hypertensive type 2 diabetic patients. *J Hypertens.* 2006;24(7):1397–403.
- Kannel WB, Garrison RJ, Dannenberg AL. Secular blood pressure trends in normotensive persons: the Framingham study. *Am Heart J.* 1993;125(4):1154–8.
- Kearney PM, Whelton M, Reynolds K, Muntner P, Whelton PK, He J. Global burden of hypertension: analysis of worldwide data. *Lancet.* 2005;365(9455):217–23.
- Kjeldsen SE, Berge E, Bangalore S, Messerli FH, Mancia G, Holzhauer B, et al. No evidence for a J-shaped curve in treated hypertensive patients with increased cardiovascular risk: the VALUE trial. *Blood Press.* 2016;25(2):83–92.
- Knowler WC, Barrett-Connor E, Fowler SE, Hamman RF, Lachin JM, Walker EA, et al. Reduction in the incidence of type 2 diabetes with lifestyle intervention or metformin. *N Engl J Med.* 2002;346(6):393–403.
- Kosiborod M, Rasmussen HS, Lavin P, Qunibi WY, Spinowitz B, Packham D, et al. Effect of sodium zirconium cyclosilicate on potassium lowering for 28 days among outpatients with hyperkalemia: the HARMONIZE randomized clinical trial. *JAMA.* 2014;312(21):2223–33.
- Kostis JB, Wilson AC, Freudenberger RS, Cosgrove NM, Pressel SL, Davis BR, et al. Long-term effect of diuretic-based therapy on fatal outcomes in subjects with isolated systolic hypertension with and without diabetes. *Am J Cardiol.* 2005;95(1):29–35.
- Kraja AT, Vaidya D, Pankow JS, Goodarzi MO, Assimes TL, Kullo IJ, et al. A bivariate genome-wide approach to metabolic syndrome: STAMPEED consortium. *Diabetes.* 2011;60(4):1329–39.
- Krug AW, Ehrhart-Bornstein M. Aldosterone and metabolic syndrome: is increased aldosterone in metabolic syndrome patients an additional risk factor? *Hypertension.* 2008;51(5):1252–8.
- Lazich I, Bakris GL. Prediction and management of hyperkalemia across the spectrum of chronic kidney disease. *Semin Nephrol.* 2014;34(3):333–9.
- Lewis EJ, Hunsicker LG, Clarke WR, Berl T, Pohl MA, Lewis JB, et al. Renoprotective effect of the angiotensin-receptor antagonist irbesartan in patients with nephropathy due to type 2 diabetes. *N Engl J Med.* 2001;345(12):851–60.
- Liu G, Hitomi H, Hosomi N, Lei B, Nakano D, Deguchi K, et al. Mechanical stretch augments insulin-induced vascular smooth muscle cell proliferation by insulin-like growth factor-1 receptor. *Exp Cell Res.* 2011;317(17):2420–8.
- Liu Y, Wheaton AG, Chapman DP, Cunningham TJ, Lu H, Croft JB. Prevalence of healthy sleep duration among adults – United States, 2014. *MMWR Morb Mortal Wkly Rep.* 2016;65(6):137–41.
- Malatiali S, Francis I, Barac-Nieto M. Phlorizin prevents glomerular hyperfiltration but not hypertrophy in diabetic rats. *Exp Diabetes Res.* 2008;2008:305403.
- Mancia G, Grassi G, Zanchetti A. New-onset diabetes and antihypertensive drugs. *J Hypertens.* 2006;24(1):3–10.
- Mancia G, De Backer G, Dominiczak A, Cifkova R, Fagard R, Germano G, et al. 2007 ESH-ESC practice guidelines for the Management of Arterial Hypertension: ESH-ESC task force on the Management of Arterial Hypertension. *J Hypertens.* 2007a;25(9):1751–62.
- Mancia G, De Backer G, Dominiczak A, Cifkova R, Fagard R, Germano G, et al. Guidelines for the Management of Arterial Hypertension: the task force for the Management of Arterial Hypertension of the European Society of Hypertension (ESH) and of the European Society of Cardiology (ESC). *J Hypertens.* 2007b;25(6):1105–87.
- Mann JF, Schmieder RE, McQueen M, Dyal L, Schumacher H, Pogue J, et al. Renal outcomes with telmisartan, ramipril, or both, in people at high vascular risk (the ONTARGET study): a multicentre, randomised, double-blind, controlled trial. *Lancet.* 2008;372(9638):547–53.

- Margolis KL, O'Connor PJ, Morgan TM, Buse JB, Cohen RM, Cushman WC, et al. Outcomes of combined cardiovascular risk factor management strategies in type 2 diabetes: the ACCORD randomized trial. *Diabetes Care*. 2014;37(6):1721–8.
- Massiera F, Bloch-Faure M, Ceiler D, Murakami K, Fukamizu A, Gasc JM, et al. Adipose angiotensinogen is involved in adipose tissue growth and blood pressure regulation. *FASEB J*. 2001;15(14):2727–9.
- Morris RC Jr, Sebastian A, Forman A, Tanaka M, Schmidlin O. Normotensive salt sensitivity: effects of race and dietary potassium. *Hypertension*. 1999;33(1):18–23.
- Must A, Spadano J, Coakley EH, Field AE, Colditz G, Dietz WH. The disease burden associated with overweight and obesity. *JAMA*. 1999;282(16):1523–9.
- Nag S, Bilous R, Kelly W, Jones S, Roper N, Connolly V. All-cause and cardiovascular mortality in diabetic subjects increases significantly with reduced estimated glomerular filtration rate (eGFR): 10 years' data from the south tees diabetes mortality study. *Diabet Med*. 2007;24(1):10–7.
- National Kidney Foundation. KDOQI Clinical practice guidelines and clinical practice recommendations for diabetes and chronic kidney disease. *Am J Kidney Dis*. 2007;49(2 Suppl 2):S12–154.
- Neter JE, Stam BE, Kok FJ, Grobbee DE, Geleijnse JM. Influence of weight reduction on blood pressure: a meta-analysis of randomized controlled trials. *Hypertension*. 2003;42(5):878–84.
- Nishizaka MK, Zaman MA, Calhoun DA. Efficacy of low-dose spironolactone in subjects with resistant hypertension. *Am J Hypertens*. 2003;16(11 Pt 1):925–30.
- Ojima A, Matsui T, Nishino Y, Nakamura N, Yamagishi S. Empagliflozin, an inhibitor of sodium-glucose cotransporter 2 exerts anti-inflammatory and Antifibrotic effects on experimental diabetic nephropathy partly by suppressing AGEs-receptor Axis. *Horm Metab Res*. 2015;47(9):686–92.
- Oliva RV, Bakris GL. Blood pressure effects of sodium-glucose co-transport 2 (SGLT2) inhibitors. *J Am Soc Hypertens*. 2014;8(5):330–9.
- Ortola FV, Ballermann BJ, Anderson S, Mendez RE, Brenner BM. Elevated plasma atrial natriuretic peptide levels in diabetic rats. Potential mediator of hyperfiltration. *J Clin Invest*. 1987;80(3):670–4.
- Parving HH, Brenner BM, McMurray JJ, de Zeeuw D, Haffner SM, Solomon SD, et al. Cardiorenal end points in a trial of aliskiren for type 2 diabetes. *N Engl J Med*. 2012;367(23):2204–13.
- Patel SK, Wai B, Ord M, MacIsaac RJ, Grant S, Velkoska E, et al. Association of ACE2 genetic variants with blood pressure, left ventricular mass, and cardiac function in Caucasians with type 2 diabetes. *Am J Hypertens*. 2012;25(2):216–22.
- Peralta CA, Norris KC, Li S, Chang TI, Tamura MK, Jolly SE, et al. Blood pressure components and end-stage renal disease in persons with chronic kidney disease: the kidney early evaluation program (KEEP). *Arch Intern Med*. 2012;172(1):41–7.
- Perkovic V, Rodgers A. Redefining blood-pressure targets—SPRINT starts the marathon. *N Engl J Med*. 2015;373(22):2175–8.
- Powell DR, DaCosta CM, Gay J, Ding ZM, Smith M, Greer J, et al. Improved glycemic control in mice lacking Sglt1 and Sglt2. *Am J Physiol Endocrinol Metab*. 2013;304(2):E117–30.
- Pratt-Ubunama MN, Nishizaka MK, Boedefeld RL, Cofield SS, Harding SM, Calhoun DA. Plasma aldosterone is related to severity of obstructive sleep apnea in subjects with resistant hypertension. *Chest*. 2007;131(2):453–9.
- Robles RG, Villa E, Santirso R, Martinez J, Ruilope LM, Cuesta C, et al. Effects of captopril on sympathetic activity, lipid and carbohydrate metabolism in a model of obesity-induced hypertension in dogs. *Am J Hypertens*. 1993;6(12):1009–15.
- Sarafidis PA, Bakris GL. Antihypertensive therapy and the risk of new-onset diabetes. *Diabetes Care*. 2006a;29(5):1167–9.
- Sarafidis PA, Bakris GL. Antihypertensive treatment with beta-blockers and the spectrum of glycaemic control. *QJM*. 2006b;99(7):431–6.
- Sarafidis PA, Bakris GL. State of hypertension management in the United States: confluence of risk factors and the prevalence of resistant hypertension. *J Clin Hypertens*. 2008;10(2):130–9.
- Sarafidis PA, Khosla N, Bakris GL. Antihypertensive therapy in the presence of proteinuria. *Am J Kidney Dis*. 2007a;49(1):12–26.

- Sarafidis PA, McFarlane SI, Bakris GL. Antihypertensive agents, insulin sensitivity, and new-onset diabetes. *Curr Diab Rep*. 2007b;7(3):191–9.
- Saseen JJ, Carter BL, Brown TE, Elliott WJ, Black HR. Comparison of nifedipine alone and with diltiazem or verapamil in hypertension. *Hypertension*. 1996;28(1):109–14.
- Scheen AJ. Pharmacokinetics, pharmacodynamics and clinical use of SGLT2 inhibitors in patients with type 2 diabetes mellitus and chronic kidney disease. *Clin Pharmacokinet*. 2015a;54(7):691–708.
- Scheen AJ. Pharmacodynamics, efficacy and safety of sodium-glucose co-transporter type 2 (SGLT2) inhibitors for the treatment of type 2 diabetes mellitus. *Drugs*. 2015b;75(1):33–59.
- Sharma AM. Adipose tissue: a mediator of cardiovascular risk. *Int J Obes Relat Metabol Disord*. 2002;26(Suppl 4):S5–7.
- Sharma AM. Obesity and cardiovascular risk. *Growth Hormon IGF Res*. 2003;13(Suppl A):S10–7.
- Sharma AM, Janke J, Gorzelniak K, Engeli S, Luft FC. Angiotensin blockade prevents type 2 diabetes by formation of fat cells. *Hypertension*. 2002;40(5):609–11.
- Simino J, Rao DC, Freedman BI. Novel findings and future directions on the genetics of hypertension. *Curr Opin Nephrol Hypertens*. 2012;21(5):500–7.
- Sleight P, Redon J, Verdecchia P, Mancia G, Gao P, Fagard R, et al. Prognostic value of blood pressure in patients with high vascular risk in the ongoing Telmisartan alone and in combination with Ramipril global endpoint trial study. *J Hypertens*. 2009;27(7):1360–9.
- So WY, Kong AP, Ma RC, Ozaki R, Szeto CC, Chan NN, et al. Glomerular filtration rate, cardiorenal end points, and all-cause mortality in type 2 diabetic patients. *Diabetes Care*. 2006;29(9):2046–52.
- Sowers JR, Nyby M, Stern N, Beck F, Baron S, Catania R, et al. Blood pressure and hormone changes associated with weight reduction in the obese. *Hypertension*. 1982;4(5):686–91.
- SPRINT Research Group, Wright JT Jr, Williamson JD, Whelton PK, Snyder JK, Sink KM, et al. A randomized trial of intensive versus standard blood-pressure control. *N Engl J Med*. 2015;373(22):2103–16.
- Staessen JA, Li Y, Thijs L, Wang JG. Blood pressure reduction and cardiovascular prevention: an update including the 2003-2004 secondary prevention trials. *Hypertens Res*. 2005;28(5):385–407.
- Stamler J, Stamler R, Neaton JD. Blood pressure, systolic and diastolic, and cardiovascular risks. US population data. *Arch Intern Med*. 1993;153(5):598–615.
- Standards of Medical Care in Diabetes-2016. Summary of revisions. *Diabetes Care*. 2016;39(Suppl 1):S4–5.
- Stevens VJ, Obarzanek E, Cook NR, Lee IM, Appel LJ, Smith West D, et al. Long-term weight loss and changes in blood pressure: results of the trials of hypertension prevention, phase II. *Ann Intern Med*. 2001;134(1):1–11.
- Thompson D, Edelsberg J, Colditz GA, Bird AP, Oster G. Lifetime health and economic consequences of obesity. *Arch Intern Med*. 1999;159(18):2177–83.
- Thomson SC, Rieg T, Miracle C, Mansoury H, Whaley J, Vallon V, et al. Acute and chronic effects of SGLT2 blockade on glomerular and tubular function in the early diabetic rat. *Am J Physiol Regul Integr Comp Physiol*. 2012;302(1):R75–83.
- Tian F, Luo R, Zhao Z, Wu Y, Ban D. Blockade of the RAS increases plasma adiponectin in subjects with metabolic syndrome and enhances differentiation and adiponectin expression of human preadipocytes. *Exp Clin Endocrinol Diabetes*. 2010;118(4):258–65.
- Tuck ML, Sowers J, Dornfeld L, Kledzik G, Maxwell M. The effect of weight reduction on blood pressure, plasma renin activity, and plasma aldosterone levels in obese patients. *N Engl J Med*. 1981;304(16):930–3.
- UKPDS Group. Tight blood pressure control and risk of macrovascular and microvascular complications in type 2 diabetes: UKPDS 38. UK prospective diabetes study group. *BMJ*. 1998;317(7160):703–13.
- van Ittersum FJ, de Man AM, Thijssen S, de Knijff P, Slagboom E, Smulders Y, et al. Genetic polymorphisms of the renin-angiotensin system and complications of insulin-dependent diabetes mellitus. *Nephrol Dialys Transplant*. 2000;15(7):1000–7.
- Weber MA, Bakris GL, Jamerson K, Weir M, Kjeldsen SE, Devereux RB, et al. Cardiovascular events during differing hypertension therapies in patients with diabetes. *J Am Coll Cardiol*. 2010;56(1):77–85.



- Weber MA, Jamerson K, Bakris GL, Weir MR, Zappe D, Zhang Y, et al. Effects of body size and hypertension treatments on cardiovascular event rates: subanalysis of the ACCOMPLISH randomised controlled trial. *Lancet*. 2013;381(9866):537–45.
- Wedler B, Wiersbitzki M, Gruska S, Wolf E, Luft FC. Definitions and characteristics of salt-sensitivity and resistance of blood pressure: should the diagnosis depend on diastolic blood pressure? *Clin Experiment Hypertens Part A*. 1992;14(6):1037–49.
- Whelton PK, Barzilay J, Cushman WC, Davis BR, Iiamathi E, Kostis JB, et al. Clinical outcomes in antihypertensive treatment of type 2 diabetes, impaired fasting glucose concentration, and normoglycemia: antihypertensive and lipid-lowering treatment to prevent heart attack trial (ALLHAT). *Arch Intern Med*. 2005;165(12):1401–9.
- Wobeto VP, Pinho Pda C, Souza JR, Zaccariotto TR, Zonati Mde F. Haptoglobin genotypes and refractory hypertension in type 2 diabetes mellitus patients. *Arq Bras Cardiol*. 2011;97(4):338–45.
- Wright EM, Loo DD, Hirayama BA. Biology of human sodium glucose transporters. *Physiol Rev*. 2011 Apr;91(2):733–94.
- Wu Y, Xu J, Velazquez H, Wang P, Li G, Liu D, et al. Renalase deficiency aggravates ischemic myocardial damage. *Kidney Int*. 2011;79(8):853–60.
- Xie X, Atkins E, Lv J, Bennett A, Neal B, Ninomiya T, et al. Effects of intensive blood pressure lowering on cardiovascular and renal outcomes: updated systematic review and meta-analysis. *Lancet*. 2016;387(10017):435–43.
- Xu J, Li G, Wang P, Velazquez H, Yao X, Li Y, et al. Renalase is a novel, soluble monoamine oxidase that regulates cardiac function and blood pressure. *J Clin Invest*. 2005;115(5):1275–80.
- Yamout H, Perkovic V, Davies M, Woo V, de Zeeuw D, Mayer C, et al. Efficacy and safety of canagliflozin in patients with type 2 diabetes and stage 3 nephropathy. *Am J Nephrol*. 2014;40(1):64–74.
- Yatabe MS, Yatabe J, Yoneda M, Watanabe T, Otsuki M, Felder RA, et al. Salt sensitivity is associated with insulin resistance, sympathetic overactivity, and decreased suppression of circulating renin activity in lean patients with essential hypertension. *Am J Clin Nutr*. 2010;92(1):77–82.
- Zambrowicz B, Lapuerta P, Strumph P, Banks P, Wilson A, Ogbaa I, et al. LX4211 therapy reduces postprandial glucose levels in patients with type 2 diabetes mellitus and renal impairment despite low urinary glucose excretion. *Clin Ther*. 2015;37(1):71–82 e12.



# Diabetes and the Cardiovascular System

# 5

Mauro Rigato, Gian Paolo Fadini, and Angelo Avogaro

## Contents

Introduction .....	132
Mechanisms of Vascular Damage in Diabetes .....	132
Impaired Vascular Repair in Diabetes .....	135
Screening for Coronary Artery Disease in Diabetic Patients .....	136
Diabetic Cardiomyopathy and Heart Failure .....	138
Cerebrovascular Disease .....	138
Peripheral Artery Disease .....	139
Therapeutic Multifactorial Approach to Diabetic Macroangiopathy .....	140
Setting Glycemic Targets for the Prevention of Macroangiopathy .....	142
Glucose-Lowering Medications and Prevention of Macroangiopathy .....	143
Summary .....	149
References .....	149

## Abstract

Diabetes is a major risk factor for cardiovascular disease and affects the cardiovascular system through hyperglycemia-induced endothelial damage and by impairing physiologic vascular repair. Furthermore, hyperglycemia often associates with obesity, hypertension, and dyslipidemia in the cluster of metabolic syndrome. This results in an accelerated atherosclerosis, leading to a very high risk of cardiovascular events and mortality. A multifactorial approach based on the simultaneous targeting of hyperglycemia and concomitant risk factors is the most effective in reducing cardiovascular morbidity and mortality. In this context,

---

M. Rigato  
Diabetology Service, Treviso, Italy  
e-mail: [mauro.rigato@aull2.veneto.it](mailto:mauro.rigato@aull2.veneto.it)

G. P. Fadini · A. Avogaro (✉)  
Department of Medicine, Division of Metabolic Disease, University of Padova, Padua, Italy  
e-mail: [gianpaolo.fadini@unipd.it](mailto:gianpaolo.fadini@unipd.it); [angelo.avogaro@unipd.it](mailto:angelo.avogaro@unipd.it)

the choice of the most appropriate glucose-lowering medications will help the physicians to reduce the excess of cardiovascular risk in diabetic patients.

---

**Keywords**

Diabetes · Metabolic syndrome · Vascular damage · Coronary heart disease · Stroke · Peripheral artery disease

---

## Introduction

Diabetes mellitus is a major risk factor for the development of cardiovascular (CV) disease: diabetes confers a two- to fourfold increase in the risk of coronary heart disease, stroke, and peripheral artery disease (Shah et al. 2015). Macrovascular events in diabetes remain the leading cause of mortality, and the burden of cardiovascular disease attributable to diabetes has increased over the past two decades (Stratton et al. 2000; Morrish et al. 2001). Early studies suggested that on average, patients with diabetes but without a previous history of myocardial infarction have a similar risk of experiencing a future cardiac event as subjects without diabetes but with a prior myocardial infarction (Haffner et al. 1998). This high cardiovascular risk is attributed in part to the harmful effect of hyperglycemia per se on the vascular wall (Nathan et al. 2003) and in part to the coexistence of other traditional CV risk factors in the cluster of metabolic syndrome, such as hypertension, atherogenic dyslipidemia, and central obesity (Mottillo et al. 2010; Veitenhansl et al. 2004). Insulin resistance is the underlying factor for all the features of metabolic syndrome and is considered crucial in the pathophysiology of vascular damage (Stout 1969; DeFronzo 2010; Reddy et al. 2010; Kanwar et al. 2008a).

---

## Mechanisms of Vascular Damage in Diabetes

The pathophysiology of vascular damage in diabetes is complex and involves abnormalities in endothelial cells, vascular smooth muscle cells, and platelet function. Hyperglycemia reduces endothelium-derived nitric oxide (NO) availability (McVeigh et al. 1992; Williams et al. 1996) and compromises vascular function through several mechanisms, mainly involving overproduction of reactive oxygen species (ROS) from mitochondria and cytoplasmic sources (Williams et al. 1996; Baynes 1991; Cosentino et al. 1997) (Fig. 1). ROS are not only the final effectors but also the initiating factors of each of the following pathways involved in hyperglycemia-driven vascular damage (Brownlee 2001; Giacco and Brownlee 2010; Madonna and De Caterina 2011): (1) the polyol pathway (Giacco and Brownlee 2010); (2) the advanced glycation end product (AGE) formation (Goldin et al. 2006; Farmer and Kennedy 2009; Tan et al. 2002; Basta et al. 2002); (3) the de novo synthesis of diacylglycerol (DAG), leading to activation of protein kinase C (PKC) isoforms (Inoguchi et al. 1994; Xia et al. 1994; Beckman et al. 2002); and (4) the hexosamine pathway (Brownlee 2001; Giacco and Brownlee 2010). In the polyol pathway, the enzyme aldose reductase is activated by ROS and catalyzes

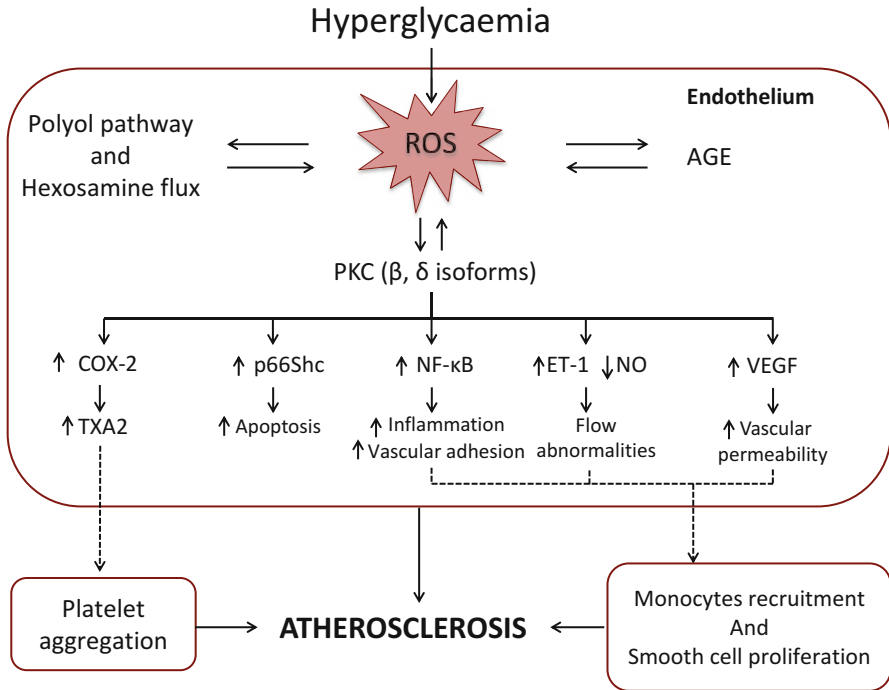

**Fig. 1 Mechanisms of hyperglycemia-induced vascular damage.** Hyperglycemia compromises vascular function via several mechanisms, mainly involving overproduction of reactive oxygen species (ROS). ROS are both the initiating factors and the final effectors of the following detrimental pathways: polyol and hexosamine fluxes, AGE formation, and PKC activation. In particular, the activation of  $\beta$  and  $\delta$  isoforms of PKC causes the overexpression of several pro-thrombotic and pro-inflammatory genes favoring vasoconstriction, platelet activation, and monocyte adhesion leading to development of atherosclerotic plaque. PKC, protein kinase C; NO, nitric oxide; AGE, advanced glycation end product; ET-1, endothelin-1; COX-2, cyclooxygenase-2; TXA2, thromboxane A2; VEGF, vascular endothelial growth factor; NF- $\kappa$ B, nuclear factor  $\kappa$ B

the conversion of glucose to sorbitol, which is oxidized in fructose in an NADPH-consuming process. In turn, the reduction of nicotinamide adenine dinucleotide phosphate reduced form (NADPH) to nicotinamide adenine dinucleotide phosphate (NADP)<sup>+</sup> leads to a decrease in the reduced isoform of glutathione, which is the main intracellular defense against oxidative stress (Brownlee 2001). Therefore, this contributes to propagating oxidative damage. The production of AGEs is the result of nonenzymatic glycation of proteins, lipids, and nucleic acid amino groups after interaction with aldose sugars. In particular, AGEs can be derived from the autooxidation of glucose to glyoxal, decomposition of the Amadori products to 3-deoxyglucosone, and fragmentation of glyceraldehyde-3-phosphate to methylglyoxal (Negre-Salvayre et al. 2009; Wendt et al. 2002). These dicarbonyls react with amino, sulfhydryl, and guanidine functional groups in proteins leading to the formation of AGEs. AGEs compromise both extracellular and intracellular function through three

mechanisms: (1) formation of cross-links between proteins in the basement membrane of extracellular matrix, leading to an increase of vascular wall stiffness (Kass et al. 2001; Hammes et al. 1996), (2) alteration of biological function of intracellular proteins modified by AGEs, and (3) binding of circulating AGEs to cell surface receptors, such as receptor for AGEs (RAGE) and macrophage scavenger receptors (Schmidt et al. 1994; Yan et al. 2010). Binding of AGEs to endothelial RAGE leads to ROS production and to upregulation of transcription of several factors such as nuclear factor- $\kappa$ B (NF- $\kappa$ B), with subsequent overexpression of many genes involved in vascular inflammation and endothelial dysfunction (Basta et al. 2002; Yan et al. 2010; Wautier et al. 2001). In endothelial cells, hyperglycemia also increases the production of diacylglycerol (DAG), by de novo synthesis from the glycolytic intermediate glyceraldehyde-3-phosphate. DAG is a potent activator of PKC (mainly of the  $\beta$  and  $\delta$  isoforms). The excessive activation of PKC causes overexpression of several pro-thrombotic and pro-inflammatory genes such as transforming growth factor (TGF)- $\beta$  (Kanwar et al. 2008b; Studer et al. 1993), plasminogen activator inhibitor-1 (PAI-1) (Feener et al. 1996; Suzuki et al. 2002), NF- $\kappa$ B (Suzuki et al. 2002; Yerneni et al. 1999; Rikitake and Liao 2005), and vascular endothelial growth factor (VEGF) (Chakrabarti et al. 2000). Furthermore, the PKC- $\beta$  isoform phosphorylates p66Shc at serine 36 promoting its translocation into the mitochondrial intermembrane space where it catalyzes the production of ROS (Cosentino et al. 2008; Paneni et al. 2012). This event triggers the mitochondrial permeability transition leading to apoptotic cell death. In diabetic mice, the deletion of p66Shc improves hyperglycemia-induced endothelial dysfunction and wound healing (Camici et al. 2007; Fadini et al. 2010). Finally, the functional consequences of the hexosamine pathway activation are the increased expression of PAI-1 (Buse 2006) and TGF- $\beta$  (Kolm-Litty et al. 1998).

Insulin resistance and compensatory hyperinsulinemia also characterize type 2 diabetes. In healthy subjects, insulin stimulates NO production by endothelial cells and glucose transporter type 4 (GLUT4) translocation via the insulin receptor substrate 1 (IRS-1)  $\rightarrow$  phosphatidylinositol-3 kinase (PI-3 K)  $\rightarrow$  Akt kinase pathway (Zeng et al. 2000; Kuboki et al. 2000). This results in endothelium-dependent vasodilatation and glucose uptake in insulin-responsive tissues. In insulin-resistant states, the PI-3 K/Akt is selectively inhibited, thus leading to vasoconstriction, enhanced expression of surface adhesion molecules, and a pro-thrombotic condition (Montagnani et al. 2002). Despite the PI-3 K/Akt pathway being impaired, signalling via the mitogen-activated protein kinase (MAPK) pathway remains intact, allowing for compensatory hyperinsulinemia to stimulate an array of proliferative and pro-atherogenic events in endothelial and vascular smooth cells (Oliver et al. 1991; Ferri et al. 1995). These events include overproduction of PAI-1, endothelin, and pro-inflammatory cytokines and the increased expression of surface adhesion molecules, such as vascular cell adhesion molecule (VCAM)-1 and monocyte chemoattractant protein (MCP)-1 (Montagnani et al. 2002; Golovchenko et al. 2000).

The impact of diabetes mellitus on vascular function is not limited to the endothelium but also involves vascular muscle cells and platelets. Diabetes increases

the migration of vascular smooth muscle cells into nascent atherosclerotic lesions, where they transdifferentiate into a myofibroblast-like secretory phenotype and produce extracellular matrix (Golovchenko et al. 2000; Ridray et al. 1995). At the same time, diabetes is also associated with the production of several pro-inflammatory cytokines that increase the release of matrix metalloproteinase, leading to an increased tendency for plaque destabilization and rupture (Fukumoto et al. 1998; Uemura et al. 2001; Suzuki et al. 2001). Platelet hyper-reactivity is considered another pivotal factor contributing to increased risk of coronary events in diabetic patients (Vinik et al. 2001; Grant 2007). Hyperglycemia alters platelet  $\text{Ca}^{2+}$  homeostasis, leading to cytoskeleton abnormalities and increased secretion of pro-aggregating cytokines. Moreover, hyperglycemia enhances the expression of both Ib and IIb/IIIa glycoproteins. Diabetes is also associated with a hypercoagulability state due to increased production of plasma factor VII, fibrinogen, and PAI-1 and a reduction of endogenous anticoagulants, such as protein C and thrombomodulin (Pandolfi et al. 2001).

As a result of all these pathological changes, the development of atherosclerotic plaques in people with diabetes is a complex progressive process, characterized by early vascular inflammation and endothelial dysfunction, leading to monocyte recruitment and subsequent formation of fatty streaks. Over the years, this leads to overt atherosclerotic plaques that in a pro-inflammatory and pro-thrombotic context become unstable and prone to rupture.

---

## Impaired Vascular Repair in Diabetes

Although the pathogenesis of vascular diabetic complications is generally focused on a well-known intracellular damage pathway triggered by oxidative stress, it has been recognized that diabetes also impairs response to vascular damage by reducing endothelial repair processes (Avogaro et al. 2011). This is most clearly represented by the shortage of bone marrow (BM)-derived vascular regenerative cells, including circulating progenitor cells (CPCs) and endothelial progenitor cells (EPCs) (Fadini 2014). EPCs are released from the bone marrow and are involved both in the homeostasis of healthy and damaged endothelium and in physiologic and compensatory angiogenesis. Considering their crucial role in cardiovascular homeostasis, the reduction of EPCs is believed to promote development and progression of cardiovascular disease. EPCs are reduced both in type 1 and type 2 diabetes, especially in the presence of macrovascular complications (Fadini et al. 2006; Sibal et al. 2009). Low EPC levels have been shown to predict future cardiovascular events and all-cause mortality in different populations (Werner et al. 2005; Schmidt-Lucke et al. 2005; Patel et al. 2015), including patients with chronic kidney disease (CKD) (Maruyama et al. 2008) and metabolic syndrome (Fadini et al. 2009). Furthermore, low EPC levels have been reported to predict the development and progression of microvascular complication in type 2 diabetes mellitus (T2DM) (Rigato et al. 2015). Altogether, these data indicate that a shortage in vascular regenerative cells contributes to the high cardiovascular risk in diabetic patients, by preventing a normal repair of ongoing endothelial damage.

## Screening for Coronary Artery Disease in Diabetic Patients

Coronary artery disease (CAD) is often asymptomatic in diabetic patients, and up to 60% of myocardial infarctions may be clinically silent and detected only by systematic electrocardiogram screening (Valensi et al. 2011). Silent myocardial ischemia is the consequence of the autonomic and sensitive neuropathy, affecting up to 30% of diabetic subjects. These patients often experience atypical symptoms of ischemia such as fatigue or shortness of breath during physical activity in the absence of typical chest pain. Silent myocardial ischemia has been reported to be associated with significant coronary stenosis on angiography in 35–70% of patients. However, it is still controversial whether screening for CAD in asymptomatic diabetic patients is cost-effective. The Detection of Ischemia in Asymptomatic Diabetics (DIAD) study (Young et al. 2009) is the only randomized trial to investigate the clinical value of CAD screening in asymptomatic diabetic patients. This study demonstrated no differences in cardiovascular outcomes between two cohorts of type 2 diabetic patients with normal resting ECG, randomized to myocardial scintigraphy or follow-up alone. According to these results, the screening of CAD in asymptomatic patients may not be considered cost-effective and is actually not recommended by the American Heart Association (AHA) (Fox et al. 2015) and American Diabetes Association (ADA) (ADA 2015) guidelines. This position is in part justified because all diabetic patients should be considered as having a high cardiovascular risk and should receive multifactorial intensive medical therapy, an approach that has been reported to provide similar benefits as invasive revascularization. However, the European Society of Cardiology (ESC) guidelines, developed in collaboration with the European Association for the Study of Diabetes (EASD) (Authors/Task Force Members ESC/EASD 2013), suggest performing the screening also in asymptomatic patients at particular high risk such as those with evidence of target organ damage. These include patients with peripheral artery disease, high coronary artery calcium (CAC) score, low ankle-brachial index (ABI), increased carotid intima-media thickness, microalbuminuria, chronic kidney disease, photocoagulated retinopathy, autonomic neuropathy, and erectile dysfunction. Indeed, microvascular complications are closely related to clinical or subclinical damage of large arteries. Microalbuminuria (MA), a urinary albumin excretion between 30 and 300 mg per day, is not only a well-known marker of diabetic nephropathy but has also been associated with an increased risk of cardiovascular morbidity and mortality in diabetic patients (Rossing et al. 1996; Monhart 2011). MA should be considered as a renal sign of systemic endothelial dysfunction and is associated with increased levels of several inflammatory markers (Kalaitzidis and Bakris 2009). Reinhard et al. showed that half of asymptomatic T2DM patients with MA have significant atherosclerosis at least in one vascular territory, with higher prevalence for coronary disease (Reinhard et al. 2011). Furthermore, patients with CVD and MA have more severe angiographically detected coronary disease than those without MA (Khan et al. 2013). Several studies demonstrated a direct association between erectile dysfunction (ED) and CVD in diabetic patients (Thompson et al. 2005;

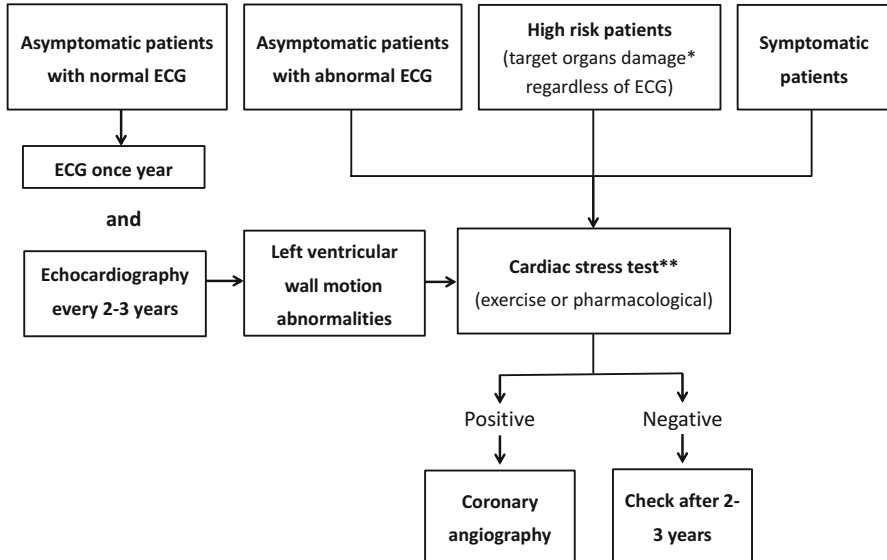

**Fig. 2 Diagnostic flowchart for ischemic heart disease in diabetic patients.** It is reasonable to refer to a stress test all diabetic patients with typical or atypical cardiac symptoms, those with abnormal resting ECG, and those with evidences of organ damage even without ECG abnormalities. If the stress test is positive, coronary angiography should be performed. \*Target organ damage includes peripheral artery disease, high coronary artery calcium (CAC) score, low ankle-brachial index (ABI), increased carotid intima-media thickness, proteinuria, chronic kidney disease, laser-treated retinopathy, autonomic neuropathy, and erectile dysfunction. \*\*Cardiac stress tests include ECG exercise tolerance test, pharmacological myocardial perfusion imaging, or pharmacological stress echocardiography (Adapted from 2016 Italian Standard of Care in Diabetes)

Frantzen et al. 2006). In particular, ED seems to be a strong and independent risk factor for silent coronary artery disease in apparently uncomplicated T2DM patients (Gazzaruso et al. 2004; Meena et al. 2009). Several studies reported that retinopathy predicted all-cause and CV mortality independently of other traditional CV risk factors, both in diabetic (Juutilainen et al. 2007; Miettinen et al. 1996; Rong et al. 2013) and nondiabetic patients (Liew et al. 2009). These evidences suggest that retinopathy and coronary disease may share similar pathophysiological backgrounds and are of particular interest because the retina is the only site where condition of the systemic microcirculation can be noninvasively imaged. Therefore, the presence of microalbuminuria, erectile dysfunction, and retinopathy should be investigated in all diabetic patients in order to better stratify their CV risk. In conclusion, it is reasonable to candidate for advanced or invasive cardiac testing diabetic patients with typical or atypical cardiac symptoms, those with abnormal resting ECG and those with evidences of organ damage even if asymptomatic and without ECG abnormalities. All these patients should be referred to a stress test (e.g., ECG exercise tolerance test, exercise or pharmacological myocardial perfusion imaging, exercise or pharmacological stress echocardiography) and if positive to coronary angiography (Fig. 2).



## Diabetic Cardiomyopathy and Heart Failure

The prevalence of diabetes in people with symptomatic heart failure is 12–30%, increasing up to 40% among hospitalized patients (MacDonald et al. 2008). On the other hand, a high incidence of heart failure in diabetic patients was observed in the National Health and Nutrition Examination Survey (NHANES-I), where the rate of heart failure was twofold higher in patients with compared to those without diabetes (He et al. 2001). Diabetes is commonly associated with risk factors for heart failure, such as hypertension and ischemic heart disease. However, hyperglycemia itself has a detrimental effect on myocardial function, often resulting in ventricular dysfunction in the absence of coronary atherosclerosis. This condition is known as diabetic cardiomyopathy and results from alterations in the coronary microcirculation (Avogaro et al. 2004; Francis 2001; Poornima et al. 2006) and myocardial energy metabolism (Rana et al. 2015). In clinical studies of asymptomatic diabetic patients, the most commonly observed cardiac abnormalities were left ventricular hypertrophy and diastolic dysfunction, particularly among women. Insulin resistance impairs myocardial function reducing the influx of calcium through L-type  $\text{Ca}^{2+}$  channels and reversing sodium/calcium exchange. Activation of ROS-driven pathways by chronic hyperglycemia leads to myocardial hypertrophy and fibrosis with ventricular stiffness and early diastolic dysfunction (Poornima et al. 2006). In the Hypertension, Microalbuminuria or Proteinuria, Cardiovascular Events, and Ramipril (DIABHYCAR) trial (Vaur et al. 2003), heart failure was a major cause of hospitalization in type 2 diabetic patients with albuminuria. Type 2 diabetes increased the risk of hospitalization in patients with heart failure also in the BETA blocker STroke (BEST) trial (Domanski et al. 2003).

---

## Cerebrovascular Disease

Diabetes is a major risk factor for development of carotid atherosclerosis and stroke, both ischemic and hemorrhagic (Wolf et al. 1991; Khoury et al. 2013; Iso et al. 2004; Manolio et al. 1996; Karapanayiotides et al. 2004). Data from the Emerging Risk Factors Collaboration found that diabetes was associated with a 2.27 (95% CI, 1.95–2.65)-fold increase in the risk of ischemic stroke and a 1.56 (95% CI, 1.19–2.05)-fold increase in the risk of hemorrhagic stroke (Emerging Risk Factors Collaboration 2010). Similar results were reported by the INTERSTROKE trial, a case-control study performed in 22 nations worldwide (O'Donnell et al. 2010). According to evidences from the Greater Cincinnati/Northern Kentucky Stroke Study, the risk of ischemic stroke was increased in all ages but was most striking before 55 years in African-Americans and before 65 years in Whites (Khoury et al. 2013). Furthermore, diabetes is actually considered an established risk factor for incidence cognitive impairment, dementia, and Alzheimer disease (Gorelick 2012; Ott et al. 1999; Peila et al. 2002; Biessels et al. 2006). Imaging studies showed that cortical atrophy in T2DM resembles a pattern seen in preclinical Alzheimer disease (Moran et al. 2013). The mechanisms underlying brain atrophy in T2DM are complex and may include

endocrine, metabolic, and vascular pathways (Exalto et al. 2012). Indeed, hyperglycemia and insulin resistance have been associated with impaired cerebral perfusion and intracellular  $\beta$ -amyloid accumulation (Cholerton et al. 2011; Correia et al. 2012). Even if it is clear that diabetes increases the risk of stroke, it has been difficult to prove whether a high glucose control effectively reduces this risk. Results from landmark trials failed to show a benefit of intensive glucose control in reducing the risk of ischemic stroke. This discrepancy is counterintuitive, but a possible explanation is given by the most harmful effect of concomitant risk factors, such as hypertension and dyslipidemia, compared to that of hyperglycemia per se. The Action to Control Cardiovascular Risk in Diabetes Blood Pressure (ACCORD-BP) trial showed a significant reduction in the annual rate of total (HR 0.59; 95% CI, 0.39–0.89;  $p = 0.01$ ) and nonfatal (HR 0.63; 95% CI, 0.41–0.96;  $p = 0.03$ ) stroke in T2D patients assigned to intensive blood pressure therapy compared to standard treatment (Barzilay et al. 2012). However, the most important results in reducing stroke risk in diabetic patients have been observed with the statin therapy. The Collaborative Atorvastatin Diabetes Study (CARDS) showed that atorvastatin significantly reduced the risk of stroke (HR 0.52; 95% CI, 0.31–0.89) in diabetic patients with no history of cardiovascular disease and without high LDL cholesterol concentrations (Colhoun et al. 2004). Similarly, in the Heart Protection Study (HPS), diabetic patients assigned to simvastatin experienced a significant 24% reduction in fatal and nonfatal stroke (Collins et al. 2003). These evidences highlight the need of multifactorial approach in the primary prevention of cerebrovascular disease in diabetic patients.

---

## Peripheral Artery Disease

Diabetes is also associated with a twofold increase in the risk of lower limb ischemia, and an estimated 21% of patients have signs of peripheral artery disease (PAD) (Crique 2001). Even if foot problems are generally attributed to neuropathy and loss of protective sensation, the majority of ulcers also have an ischemic component. Routine assessment of vascular perfusion detects some degree of PAD in at least 50–60% of patients with diabetic ulcers (Armstrong et al. 2011; Ndip and Jude 2009). In diabetes, lower limb ischemia is characterized by multifocal stenosis often located in distal vessels and by calcification of the tunica media. The progression of lower limb ischemia may lead to foot ulcer, gangrene, and amputation. Indeed, diabetes is the first cause of non-traumatic amputations in Western countries, and 5-year survival after amputation is less than 50% (Morbach et al. 2012). The dramatic consequence of diabetic foot imposes a heavy burden on worldwide healthcare systems. In the USA, the cost of treating diabetic foot complications accounts for 20% of the total annual \$116 billion healthcare expenditures for diabetes care. For these reasons, annual clinical screening to detect peripheral artery disease is recommended in all diabetic patients. Patients without palpable foot pulses should undergo noninvasive testing such as ankle-brachial index (ABI) determination, toe systolic pressure (TSP) measurement, transcutaneous partial oxygen pressure (TcPO<sub>2</sub>) evaluation, and Doppler ultrasound (Abovans et al. 2017). The ABI is the most widely and validated tool to diagnose PAD

and normally ranges from 0.9 to 1.3. An ABI lower than 0.9 is commonly used to diagnose PAD, both symptomatic and asymptomatic. PAD is prospectively related to morbidity or mortality from other types of atherosclerotic disease and may serve as a marker for underlying silent atherosclerotic processes affecting other vascular beds (Criqui and Aboyans 2015). For these reasons, all patients with documented PAD should receive proper lipid-lowering and antihypertensive and antiplatelet treatment in addition to optimal glycemic control (Authors/Task Force Members ESC/EASD 2013). Revascularization procedures should be performed when critical ischemia is present. However, despite a general increase in accessibility to such procedures, still up to 50% of patients with critical limb ischemia are not candidate to revascularization, and long-term mortality remains high. In such patients, autologous cell therapy may represent a safe option to reduce risk of amputation and ameliorate surrogate indexes of perfusion (Rigato et al. 2017).

---

## **Therapeutic Multifactorial Approach to Diabetic Macroangiopathy**

The efficacy of controlling single risk factors in preventing CV events in diabetic patients has been proved by several studies. However, the higher benefit results from multifactorial intervention. In the STENO-2 trial (Gaede et al. 2008), patients with T2DM and persistent microalbuminuria were randomized to receive either conventional multifactorial intervention or intensified, target-driven, multifactorial intervention involving a combination of medications and focused behavior modifications. In the intensive group, targets included a glycated hemoglobin level of less than 6.5%, fasting values of serum total cholesterol level or less than 175 mg per deciliter (4.5 mmol per liter), fasting serum triglycerides level or less than 150 mg per deciliter (1.7 mmol per liter), a systolic blood pressure less than 130 mmHg, and diastolic blood pressure less than 80 mmHg. The mean duration of treatment period was 7.8 years, and patients were subsequently followed for a mean of 5.5 years. At the end of treatment period, the intensive therapy was superior to conventional therapy in controlling the level of all mentioned risk factors, but these differences were lost during the subsequent years. At the end of the entire follow-up period (13.3 years), the intensive therapy was associated with an absolute risk reduction of total mortality by 20% and of CV events by 29% compared to conventional therapy. These data suggest that in type 2 diabetic patients at very high CV risk, an intensified multifactorial approach with combination of multiple drugs and behavior modification is associated with a reduction of vascular complications and of death from any cause and from cardiovascular causes.

The prevalence of hypertension is extremely higher in diabetic patients compared to the general population, reaching up to 60% in T2DM (Nilsson et al. 2011) and up to 50% in T1DM (Cleary et al. 2006; Soedamah-Muthu et al. 2002). In T1DM, hypertension is often the result of underlying nephropathy, while in T2DM it may be considered as a feature of the metabolic syndrome. Insulin resistance and compensatory hyperinsulinemia promote the development of hypertension via several

mechanisms (Redon et al. 2009). These include increased renal sodium reabsorption, activation of the sympathetic nervous system, and alteration in vascular resistance through increased  $\text{Ca}^{2+}$  concentration in smooth muscle cells. The recommended targets of blood pressure in diabetic patients have been debated in the past years. The ACCORD-BP (Barzilay et al. 2012) evaluated whether, in T2DM patients, the reduction of systolic blood pressure (SBP) below 120 mmHg provided greater cardiovascular protection than standard control (SBP of 130–140 mmHg). The study did not show any difference in the reduction of the primary composite end point (cardiovascular death, nonfatal myocardial infarction, and nonfatal stroke) comparing intensive versus standard control. Furthermore, the prevalence of adverse events, such as hypotension and worsening of renal function, was significantly higher in the intensive group of treatment. In line with the ACCORD results, a recent meta-analysis of randomized trials comparing intensive versus standard targets of blood pressure in T2DM found no difference in the reduction of mortality and myocardial infarction (McBrien et al. 2012). Intensive targets were associated with a significant reduction of 35% in the relative risk of stroke but also with an increased risk of adverse events, such as hypotension. According to these evidences, the international guidelines for management of hypertension in diabetes suggest to achieve and maintain SBP <140 mmHg and DPB <90 mmHg (ADA 2015; Authors/Task Force Members ESC/EASD 2013; James et al. 2014). A threshold of DBP <80 mmHg should be considered for patients with long life expectancy and those with chronic renal impairment with albuminuria. Pharmacological therapy of hypertension in diabetes should be based on regimens that include an ACE inhibitor (HOPE Study Investigators 2000; Ruggenenti et al. 2004) or an angiotensin receptor blocker (ARB) (Lindholm et al. 2002), though a multiple drug therapy is generally required to achieve the blood pressure target.

Type 2 diabetes is associated with a cluster of metabolically linked lipid abnormalities, leading to increased production of triglycerides, low levels of high-density lipoproteins (HDL), and generation of small and dense low-density lipoproteins (LDL). The level of LDL cholesterol may be elevated, borderline, or normal, but for any LDL cholesterol concentration, there will be a higher number of small and dense LDL particles in patients with than in those without diabetes, which seem to be more prone to glycation and oxidation. LDL cholesterol is actually considered the principal target of lipid-lowering therapy. A meta-analysis, evaluating data from 18,686 diabetic patients from 14 randomized trials of statin therapy during a median follow-up of 4.3 years, demonstrated a proportional reduction of 21% in major CV events, of 13% in CV mortality, and of 9% in all-cause mortality per 1 mmol/L (30 mg/dL) reduction in LDL cholesterol (Cholesterol Treatment Trialists' Collaborators 2008). For these reasons, the lipid profile should be determined at least annually in patients with diabetes mellitus. Lifestyle modifications should be encouraged in order to achieve a reduction of saturated and trans fat intake and weight loss and increases of physical activity and dietary vegetable intake. The AHA/ACC cholesterol guidelines according to the ADA position statement suggest to consider moderate to intense statin treatment for all diabetic patients who are >40 years of age (Fox et al. 2015). For those with CV risk factors (e.g., LDL cholesterol  $\geq$ 100 mg/dL

[2.6 mmol/L], hypertension, smoking, and overweight or obesity), high-dose statins are recommended. For diabetic patients under the age of 40 years, treatment with moderate dose of statins should be considered if cardiovascular risk factors are present. Regardless of age, treatment with high-dose statin is recommended for all patients with overt CVD. Several landmark trials have demonstrated that despite control of LDL cholesterol, diabetic patients remain at risk for CV events (Cannon et al. 2004; Pedersen et al. 2005; LaRosa et al. 2005). It has been suggested that this residual risk should be linked to persistence of high level of triglycerides and low HDL cholesterol. However, clinical trials conducted to date failed to support a beneficial effect of triglyceride reduction in preventing CVD. Three trials, the Fenofibrate Intervention and Event Lowering in Diabetes (FIELD) (Keech et al. 2005), the Action to Control Cardiovascular Risk in Diabetes Lipid Trial (ACCORD-LIPID) (ACCORD Study Group 2010), and the Bezafibrate Infarction Prevention (BIP) (The BIP Study Group 2000), did not show any CV protection in diabetic patients treated with fibrate alone or in combination with statins. Recently, the post hoc analysis of these trials suggested a possible benefit of combination therapy for diabetic patients with triglycerides  $\geq 204$  mg/dL (2.3 mmol/L) and HDL cholesterol  $\leq 34$  mg/dL (0.9 mmol/L) (Scott et al. 2009).

The use of aspirin for the primary prevention of CVD events in patients with diabetes mellitus remains controversial. The results of trials examining the effect of aspirin for primary prevention in diabetic patients suggest a modest relative reduction (9–10%) in risk of CVD and twofold relative increase in the risk of bleeding, mainly from the gastrointestinal tract (Calvin et al. 2009; De Berardis et al. 2009). Aspirin use should be considered for primary prevention only among diabetic patients with a 10-year CVD risk  $> 10\%$  and without an increased risk of bleeding (Pignone et al. 2006, 2007).

---

## Setting Glycemic Targets for the Prevention of Macroangiopathy

Despite the strong association between hyperglycemia and CVD risk, the evidence that intensive glycemic control reduces this risk is limited, compared with the well-proven risk reduction in microvascular complications. The Diabetes Control and Complications Trial (DCCT) and its follow-up, the Epidemiology of Diabetes Interventions and Complications (EDIC) (Nathan et al. 2005), demonstrated that intensive glycemic control in patients with type 1 diabetes not only reduced the risk of microvascular complications but also the risk of any cardiovascular event and of MACE (composite of CV death, MI, and stroke) by 42% and 57%, respectively. More recently, the UK Prospective Diabetes Study 10-year follow-up (Holman et al. 2008) has clearly demonstrated the long-term benefit of early good glycemic control on the risk of ischemic heart disease in patients with newly diagnosed type 2 diabetes (15% risk reduction,  $p = 0.01$ ). On the other hand, three large randomized controlled trials (Action to Control Cardiovascular Risk in Diabetes [ACCORD] (ACCORD Study Group 2008), Action in Diabetes and Vascular Disease: Preterax and Diamicon Modified-Release Controlled Evaluation [ADVANCE] (ADVANCE Collaborative

Group 2008), Veterans Affairs Diabetes Trial [VADT] (Duckworth et al. 2009)) evaluated the effect of strict versus conventional glycemic control on cardiovascular events in patients with well-established type 2 diabetes and high cardiovascular risk. The baseline value of HbA1c was 7.2% in ADVANCE, 8.1% in ACCORD, and 9.4% in VADT. After intensive therapy HbA1c was reduced to 6.4% in ACCORD and ADVANCE and to 6.9% in VADT. After standard therapy, the values were 7.5%, 7.0%, and 8.4%, respectively. None of these studies showed a significant reduction in cardiovascular end points in the group receiving intensive treatment. The ACCORD trial was prematurely terminated, owing to an excess of cardiovascular mortality in the intensive treatment group, possibly related to a threefold higher rate of hypoglycemia (Boussageon et al. 2011). The results of the aforementioned trials suggest that it is important to individualize glycemic targets according to the clinical history and characteristics of each patient. The American Diabetes Association and the European Association for the Study of Diabetes recommend lowering HbA1c to 7.0% (53 mmol/mol) to reduce the risk of microvascular complications, but this target is not universally valid for all patients. More stringent targets (HbA1c 6.0–6.5%) may be considered for selected patients with a short disease duration, low risk of hypoglycemia, no cardiovascular disease, and long life expectancy. Conversely, less aggressive targets (HbA1c 7.0–8.0%) should be considered for elderly patients with long disease duration, advanced complications, a high risk of hypoglycemia, and/or limited life expectancy (Inzucchi et al. 2015).

---

## Glucose-Lowering Medications and Prevention of Macroangiopathy

Since diabetes is associated with increased risk of vascular complications, the ideal glucose-lowering agent should be efficient in terms of glycemic control and safe in terms of cardiovascular risk. In particular, it may be characterized by low or absent hypoglycemic risk, no weight gain, and positive effects on traditional cardiovascular risk factor such as hypertension, dyslipidemia, and endothelial dysfunction (Ferrannini and DeFronzo 2015). We herein present a brief overview of the cardiovascular effects of traditional and new glucose-lowering agents (Fig. 3).

Metformin is the first-line agent recommended by ADA, European Association for the Study of Diabetes (EASD), and International Diabetes Federation guidelines for the treatment of type 2 diabetes (Inzucchi et al. 2015). In the UKPDS, metformin significantly reduced the risk of myocardial infarction (MI), CV death, and all-cause death by 39%, 50%, and 35%, respectively, in a subgroup of 753 newly diagnosed overweight patients (UKPDS Study Group 1998). Meta-analysis and many retrospective studies also concluded that metformin reduces risk of CVD, but in most of these studies, sulfonylureas were the active comparator, and it was impossible to establish if metformin reduced or sulfonylureas increased CV events (Evans et al. 2006; Schramm et al. 2011; Roumie et al. 2012; Johnson et al. 2002). The study by Hong et al. (2013) compared treatment with metformin or glipizide in a small cohort of type 2 diabetic

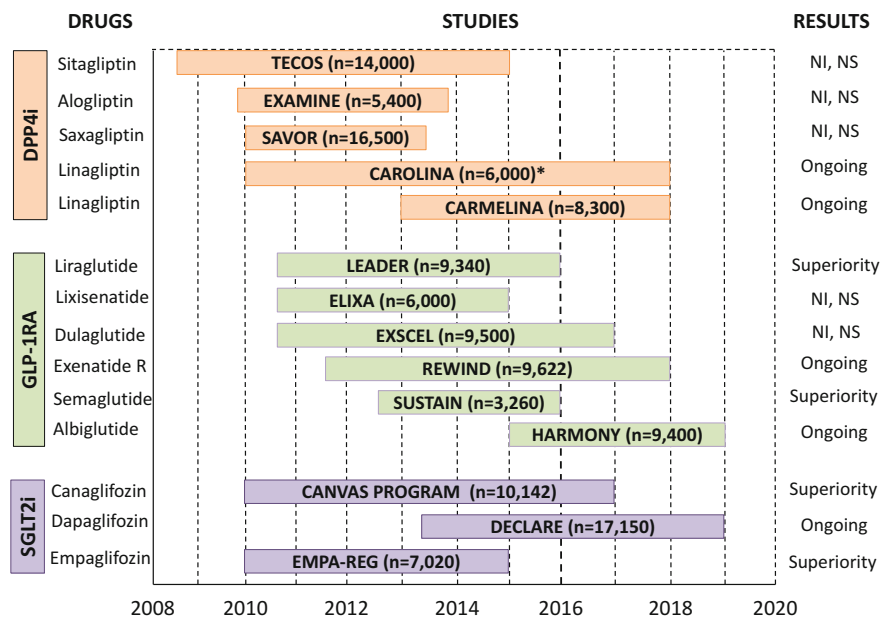

**Fig. 3 Cardiovascular outcome trials in type 2 diabetes.** All indicated trials aim to compare the experimental drugs versus placebo except for \*CAROLINA wherein linagliptin is being compared to sulfonylurea. NI, non-inferiority; NS, non-superiority

patients with coronary disease during a median follow-up of 5 years. The hazard ratio for the composite CV end point was significantly reduced in the metformin group (HR 0.54;  $p = 0.026$ ). Metformin may exert putative cardiovascular protection via several mechanisms. These include improvement in endothelial dysfunction (de Jager et al. 2014), reduction of PAI-1 levels (Nagi and Yudkin 1993), decreased VLDL secretion, and reduction of plasma triglycerides and of postprandial lipemia (Schneider et al. 1990; Grosskopf et al. 1997).

Sulfonylureas (SUs) have been widely used in the management of diabetes in the past six decades. However, these drugs are commonly associated with detrimental cardiovascular side effects resulting from increased risk of hypoglycemia, weight gain, and impairment of cardiac ischemic preconditioning (Tayek 2008; Klepzig et al. 1999; Del Prato and Pulizzi 2006). Concerns about the cardiovascular safety of SUs arose in the 1970s with the results of the University Group Diabetes Program trial, wherein tolbutamide was associated with increased cardiovascular mortality (Meinert et al. 1970). Subsequently, the UKPDS, ACCORD, and ADVANCE trials failed to show an increase of cardiovascular mortality in patients treated with sulfonylureas, even if many retrospective analyses suggested an increase in the risk of cardiovascular events and mortality related to the SU use (Morgan et al. 2014). Recently, the meta-analysis by Monami et al. (2013) reported an increased risk in all-cause mortality but not in CV events in patients treated with sulfonylureas. In a retrospective observational study, Schramm et al. (2011) evaluated mortality

rates associated with different sulfonylureas monotherapies compared to metformin. Glibenclamide, tolbutamide, glimepiride, and glipizide were associated with the higher risk of CV and overall mortality and morbidity compared to metformin. Gliclazide appears to be associated with a lower risk than other SUs and should be preferred if a SU has to be used.

Thiazolidinediones (TZDs, pioglitazone, and rosiglitazone) act as agonist of peroxisome proliferator-activated receptor-gamma (PPAR-gamma) and are the only true insulin-sensitizing agents used for the treatment of type 2 diabetes (Eldor et al. 2013). In 2011, the Food and Drug Administration (FDA) restricted the use of rosiglitazone in the USA, and the drug was withdrawn in Europe due to concerns about a possible increased risk of ischemic coronary events, which recently has been disproved (U.S. Food and Drug Administration 2011). In addition to the glucose-lowering effect, pioglitazone exerts an array of positive effects on multiple CV risk factors: it reduces the level of serum triglycerides and free fatty acids (FFA), converts small and dense LDL-C particles in larger and less detrimental particles (Nicholls et al. 2011), increases HDL-C level (Davidson et al. 2008), reduces blood pressure (Sarafidis and Nilsson 2006), decreases visceral fat (Eldor et al. 2013), and improves endothelial dysfunction (Martens et al. 2005) by reducing the level of pro-inflammatory factors, such as C-reactive protein (CRP), tumor necrosis factor- $\alpha$  (TNF- $\alpha$ ), and PAI-1. In the PROactive (Dormandy et al. 2005) study, a prospective, randomized, placebo-controlled trial involving more than 5000 patients at high CV risk, pioglitazone therapy was associated with a nonsignificant 10% reduction of the primary end point (composite of mortality, nonfatal MI, silent MI, stroke, acute coronary syndrome, coronary artery bypass grafting/percutaneous coronary intervention, leg amputation, and leg revascularization) and with a significant 16% reduction of the secondary end point, a composite of all-cause mortality, nonfatal MI, and stroke. In two subgroups of patients with previous MI or previous stroke, pioglitazone reduced the risk of recurrent MI and recurrent stroke, respectively, by 16% and 47% (Wilcox et al. 2007; Erdmann et al. 2007). In PROactive, pioglitazone was also associated with a significant increased incidence of nonfatal heart failure, likely due to its fluid retention effect. For this reason, pioglitazone is contraindicated in patients with heart failure, classes III–IV NYHA. The positive CV effects of pioglitazone have also been confirmed by the PERISCOPE (Nicholls et al. 2011) and CHICAGO (Mazzone et al. 2006) trials in which pioglitazone slowed the anatomical progression of carotid atherosclerotic plaques compared to glimepiride. However, in the recent Thiazolidinediones or Sulfonylureas and Cardiovascular Accidents Intervention Trial (TOSCA.IT), incidence of cardiovascular events was similar with sulfonylureas (mostly glimepiride and gliclazide) and pioglitazone as add-on treatments to metformin, in a cohort of 3028 Italian diabetic patients at low CV risk (Vaccaro et al. 2017).

Alpha-glucosidase inhibitors (e.g., acarbose) inhibit the absorption of glucose in the gastrointestinal tract. In the Study To Prevent Non-insulin-Dependent Diabetes Mellitus (STOP-NIDDM) (Chiasson et al. 2002), acarbose was associated with a significant 49% relative reduction in cardiovascular events in patients with impaired glucose tolerance. In a recent observational study on a wide cohort of type 2 diabetic



patients in Taiwan, acarbose as first-line therapy was associated with an increased risk of any CV events, heart failure, and stroke compared to metformin (Chang et al. 2015). These results do not support a detrimental effect of acarbose on cardiovascular risk but rather suggest a neutral effect compared to the well-known cardioprotective effect of metformin.

Incretin-based therapies, including dipeptidyl peptidase-4 inhibitors (DPP-4) and glucagon-like peptide-1 receptor agonists (GLP-1RA), are relatively new anti-hyperglycemic agents that significantly improve glycemic control without hypoglycemia or weight gain. DPP-4 inhibitors (such as sitagliptin, vildagliptin, saxagliptin, linagliptin, and alogliptin) prolong the half-life of endogenous GLP-1 by preventing its enzymatic degradation. In clinical trials, these agents have not shown significant improvements in blood pressure, LDL-C, HDL-C, and triglycerides. However, they have been reported to improve endothelial dysfunction (Matsubara et al. 2013), to increase the levels of circulating EPCs, and to exert an anti-inflammatory effect via reduction of hsCRP and modulation of monocyte-macrophage polarization toward an anti-inflammatory phenotype (Fadini et al. 2015). Pooled analysis of phase III trials with individual DPP-4 inhibitors (Williams-Herman et al. 2010; Schweizer et al. 2010; White et al. 2013; Frederich et al. 2010; Johansen et al. 2012) and meta-analysis with all agents (Richter et al. 2008) also reported a significant reduction of CV events. Recently, the results of three large prospective CV outcome trials suggested no CV benefit of saxagliptin, alogliptin, and sitagliptin therapies compared to placebo. The Saxagliptin Assessment of Vascular Outcomes Recorded in Patients with Diabetes Mellitus (SAVOR) (Scirica et al. 2013) randomized 16,492 T2DM patients, with a history of or at high risk for CVD, to saxagliptin or placebo in addition to usual care. At the end of follow-up period (median of 2.1 years), the rate of primary end point (a composite of cardiovascular death, nonfatal MI, or ischemic stroke) was similar in the two groups, but hospitalization for heart failure was significantly higher in the saxagliptin group. Despite several speculations, the reason for increased risk of heart failure remains unknown. The Examination of Cardiovascular Outcomes with Alogliptin Versus Standard of Care in Patients With Type 2 Diabetes Mellitus and Acute Coronary Syndrome (EXAMINE) trial (White et al. 2013) randomized 5380 T2DM patients, with an acute coronary syndrome in the prior 3 months, to alogliptin or placebo in addition to usual care. At the end of follow-up period (median of 18 months), no significant difference in the rate of the primary end point (a composite of cardiovascular death, nonfatal MI, or ischemic stroke) was observed between the two groups. The Trial Evaluating Cardiovascular Outcomes with Sitagliptin (TECOS) (Green et al. 2015) randomized 14,671 T2DM patients, with history of CV disease, to sitagliptin or placebo in addition to usual care, for a median follow-up period of 3.0 years. No differences in the rate of primary end point (a composite of cardiovascular death, nonfatal MI, ischemic stroke, or hospitalization for unstable angina) were observed between the two groups.

GLP-1RAs mimic the action of endogenous GLP-1 and are resistant to DPP-4 degradation. GLP-1RAs provide clinically significant weight loss, ameliorate lipid and blood pressure profiles, and improve endothelial and myocardial function (Rigato and Fadini 2014). In the study by Sokos et al. (2006), GLP-1 infusion for

5 weeks significantly improved left ventricular ejection fraction and 6-minute walking test in 12 patients with chronic heart failure. Nikolaidis et al. (2004) demonstrated that a 72-h infusion of GLP-1 in patients with acute ST elevation myocardial infarction significantly improved LVEF and infarct area-related wall motion score. In the study by Lonborg et al. (2012), exenatide infusion in patients undergoing coronary angioplasty for STEMI significantly reduced ischemia and the myocardial salvage index after 3 months. A cardioprotective effect of GLP-1RAs has been also suggested by results of many large retrospective analyses. In the retrospective analysis of the LifeLink Database (Best et al. 2011), exenatide-treated patients displayed a lower rate of CV events, CV-related hospitalization, and all-cause hospitalization compared with those treated with other glucose-lowering drugs. The Evaluation of Lixisenatide in Acute Coronary Syndrome (ELIXA) trial (Pfeffer et al. 2015) is the first CV outcome trial to be reported with a GLP-1RA. In this study, the addition of lixisenatide to usual care did not significantly change the rate of major cardiovascular events or other serious adverse events, in a cohort of T2DM patients with a recent acute coronary syndrome.

The Liraglutide Effect and Action in Diabetes: Evaluation of Cardiovascular Outcome Results (LEADER) trial (Marso et al. 2016a) randomized a total of 9340 type 2 diabetic patients, at high CV risk, to liraglutide or placebo. After a median follow-up of 3.8 years, patients assigned to liraglutide group experienced less frequently the primary outcome, a 3-points major adverse cardiovascular events: cardiovascular death, non-fatal myocardial infarction, non-fatal stroke (3P-MACE) composite of CV death, nonfatal myocardial infarction, and nonfatal stroke (HR 0.87; 95% CI, 0.78–0.97;  $p = 0.01$ ). Furthermore, liraglutide significantly lowered the rate of CV death (HR 0.78; 95% CI, 0.66–0.93;  $p = 0.007$ ) and all-cause death (HR 0.85; 95% CI, 0.74–0.97;  $p = 0.02$ ) compared to placebo. No significant differences in the rates of nonfatal myocardial infarction, nonfatal stroke, and hospitalization for heart failure were observed between the two groups.

The results of the SUSTAIN-6 trial are partially in line with those observed in the aforementioned LEADER trial (Marso et al. 2016b). In the SUSTAIN-6 trial, 3297 patients with type 2 diabetes were randomly assigned to receive semaglutide or placebo in addition to standard care. At the end of a median follow-up of 2.1 years, the 3P-MACE primary outcome occurred less frequently in patients assigned to semaglutide group compared to placebo (HR 0.74; 95% CI, 0.58–0.95;  $p = 0.02$ ). The rate of nonfatal stroke was significantly lower in semaglutide group (HR 0.61; 95% CI, 0.38–0.99;  $p = 0.04$ ), while those of cardiovascular death and nonfatal myocardial infarction were not significantly different between the two groups. Rates of new or worsening nephropathy were lower in the semaglutide group, but rates of retinopathy complications were significantly higher (HR 1.76; 95% CI, 1.11–2.78;  $p = 0.02$ ).

More recently, the Exenatide Study of Cardiovascular Event Lowering (EXSCEL) trial (Holman et al. 2017) showed that exenatide, administered once weekly, was not superior to placebo in reducing the 3P-MACE primary outcome, in a cohort of 14,752 type 2 diabetic patients at high cardiovascular risk.

The mechanisms for improved CV outcomes with semaglutide and liraglutide but not with lixisenatide and long-release exenatide are not clear. The ongoing trials with

albiglutide (HARMONY) and dulaglutide (REWIND) will help to clarify the reasons for a different cardioprotective effect among the various molecules of this class of drugs.

Insulin is the elective drug in the treatment of T1DM and one of the most used agents in T2DM. However, the effects of insulin therapy on vascular function are still controversial. *In vitro* and *in vivo* studies have shown that insulin may exert both pro-atherogenic and anti-atherogenic effects. Insulin signalling via IRS-1/PI3K/Akt pathway has been associated with antiproliferative and antithrombotic effects with NO-dependent vasodilation and decreased expression of adhesion molecules (Zeng et al. 2000; Kuboki et al. 2000). In contrast, the effects on vascular smooth cell proliferation and migration are mediated via the mitogen-activated protein kinase (MAPK) pathway, which is stimulated in condition of insulin resistance (Montagnani et al. 2002; Oliver et al. 1991; Ferri et al. 1995). Many retrospective analyses have reported an increased prevalence of CVD in insulin-treated patients (Currie et al. 2013; Gamble et al. 2010), but this is likely to be the result of confounding by indication or reverse causality. In fact, evidences from two large prospective trials (UKPDS and ORIGIN (Origin Trial Investigators 2012)) failed to demonstrate that insulin treatment per se is associated to increased CV risk. These results suggest that any potential pro-atherogenic effect of exogenous insulin may be overwhelmed by the beneficial effect of improved glycemic control.

Sodium-glucose co-transporter-2 inhibitors (SGLT2i) are the newest class of oral agents approved for the treatment of T2DM in the USA and Europe. These drugs exert an insulin-independent glucose-lowering action by blocking glucose resorption via SGLT2 in the proximal renal tubule. This leads to an increase of the tubular threshold for glucose reabsorption and consequently to a higher urinary glucose excretion. SGLT2i provide also a modest weight loss (2.5–3.0 kg over 6–12 months) and decrease both systolic and diastolic blood pressure, respectively, of 4–6 and 1–2 mmHg (Ptaszynska et al. 2013; Ferrannini and Solini 2012). A small increase of LDL-C and HDL-C, without changing in their ratio, has been also shown. The EMPA-REG OUTCOME (Zinman et al. 2015) is a prospective trial evaluating the CV morbidity and mortality of 7020 T2DM patients at high CV risk, randomized to empagliflozin or placebo in addition to standard care. After a median follow-up of 3.1 years, patients randomized to empagliflozin had a significant reduction in the primary end point (composite of CV death, nonfatal myocardial infarction, and nonfatal stroke) compared to patients randomized to placebo (HR 0.86;  $p = 0.04$ ). No significant differences in the rates of myocardial infarction or stroke have been observed between the two groups, but empagliflozin treatment was associated with a significantly lower rate of death from cardiovascular causes (38% relative risk reduction), hospitalization for heart failure (35% relative risk reduction), and death from any cause (32% relative risk reduction). This was the first trial to demonstrate an improvement of cardiovascular outcomes in high-risk T2DM patients by the use of a glucose-lowering agent.

The CANVAS Program comprises two sister trials: the CANVAS and CANVAS-R (Neal et al. 2017). Overall, a total of 10,142 T2DM patients at high cardiovascular risk were randomized to receive canagliflozin or placebo in addition to usual care for

a median follow-up of 2.6 years. The rate of primary outcome (a composite of CV death, nonfatal myocardial infarction, and nonfatal stroke) was significantly lower in canagliflozin group compared to placebo (HR 0.86; 95% CI, 0.75–0.97;  $p < 0.02$ ). However, no significant difference in the rates of each 3P-MACE component was observed between the two groups. Patients assigned to canagliflozin experienced less frequently progression of albuminuria (HR 0.73; 95% CI, 0.67–0.79) and the composite outcome of a sustained 40% reduction in the estimated glomerular filtration rate, the need for renal replacement therapy, or death from renal causes (HR 0.60; 95% CI, 0.47–0.77). Canagliflozin was associated with a higher risk of lower leg amputation than placebo (HR 0.60; 95% CI, 0.47–0.77).

The reasons for these striking and early cardiovascular effects are not completely understood and may in part be mediated by multiple extra-glycemic effects of SGLT2 inhibitors. The results of the ongoing trial DECLARE will help to understand whether the cardioprotective effect of empagliflozin and canagliflozin may also be extended to dapagliflozin.

---

## Summary

Diabetes affects the cardiovascular system through hyperglycemia-induced endothelial damage and by impairing physiologic vascular repair. Furthermore, diabetes associates with obesity, hypertension, and dyslipidemia, which concur to damage the vasculature. This results in an accelerated atherosclerotic process, impaired hemodynamic regulation, primary cardiac dysfunction, and, ultimately, a very high risk of cardiovascular events and mortality. A therapeutic approach based on simultaneous targeting of hyperglycemia and concomitant risk factors, together with lifestyle intervention, is likely to be most effective in preventing cardiovascular disease in diabetes. Tailoring glycemic targets and choosing the most safe glucose-lowering medications will help diabetes specialists to counter the exaggerated cardiovascular risk in diabetic patients. The study of cardiovascular abnormalities in diabetic patients and the effects of the old and new therapeutic approaches will continue to offer important insights to develop preventive and curative strategies for clinical application.

---

## References

- Aboyans V, Ricco JB, Bartelink MEL, et al. ESC guidelines on the diagnosis and treatment of peripheral arterial diseases, in collaboration with the European Society for Vascular Surgery (ESVS): document covering atherosclerotic disease of extracranial carotid and vertebral, mesenteric, renal, upper and lower extremity arteries endorsed by: the European stroke organization (ESO) the task force for the diagnosis and treatment of peripheral arterial diseases of the European Society of Cardiology (ESC) and of the European Society for Vascular Surgery (ESVS). *Eur Heart J*. 2017;39(9):763–816.
- Action to Control Cardiovascular Risk in Diabetes Study Group, Gerstein HC, Miller ME, et al. Effects of intensive glucose lowering in type 2 diabetes. *N Engl J Med*. 2008;358:2545–59.

- American Diabetes Association. Standards of medical care in diabetes-2015 abridged for primary care providers. *Clin Diabetes*. 2015;33:97–111.
- Armstrong DG, Cohen K, Courric S, Bharara M, Marston W. Diabetic foot ulcers and vascular insufficiency: our population has changed, but our methods have not. *J Diabetes Sci Technol*. 2011;5:1591–5.
- Authors/Task Force Members, Ryden L, Grant PJ, et al. ESC guidelines on diabetes, pre-diabetes, and cardiovascular diseases developed in collaboration with the EASD: the task force on diabetes, pre-diabetes, and cardiovascular diseases of the European Society of Cardiology (ESC) and developed in collaboration with the European Association for the Study of Diabetes (EASD). *Eur Heart J*. 2013;34:3035–87.
- Avogaro A, Vigili de Kreutzenberg S, Negut C, Tiengo A, Scognamiglio R. Diabetic cardiomyopathy: a metabolic perspective. *Am J Cardiol*. 2004;93:13A–6A.
- Avogaro A, Albiero M, Menegazzo L, de Kreutzenberg S, Fadini GP. Endothelial dysfunction in diabetes: the role of reparatory mechanisms. *Diabetes Care*. 2011;34(Suppl 2):S285–90.
- Barzilay JI, Howard AG, Evans GW, et al. Intensive blood pressure treatment does not improve cardiovascular outcomes in centrally obese hypertensive individuals with diabetes: the action to control cardiovascular risk in diabetes (ACCORD) blood pressure trial. *Diabetes Care*. 2012;35:1401–5.
- Basta G, Lazzerini G, Massaro M, et al. Advanced glycation end products activate endothelium through signal-transduction receptor RAGE: a mechanism for amplification of inflammatory responses. *Circulation*. 2002;105:816–22.
- Baynes JW. Role of oxidative stress in development of complications in diabetes. *Diabetes*. 1991;40:405–12.
- Beckman JA, Goldfine AB, Gordon MB, Garrett LA, Creager MA. Inhibition of protein kinase C $\beta$  prevents impaired endothelium-dependent vasodilation caused by hyperglycemia in humans. *Circ Res*. 2002;90:107–11.
- Best JH, Hoogwerf BJ, Herman WH, et al. Risk of cardiovascular disease events in patients with type 2 diabetes prescribed the glucagon-like peptide 1 (GLP-1) receptor agonist exenatide twice daily or other glucose-lowering therapies: a retrospective analysis of the LifeLink database. *Diabetes Care*. 2011;34:90–5.
- Biessels GJ, Staekenborg S, Brunner E, Brayne C, Scheltens P. Risk of dementia in diabetes mellitus: a systematic review. *Lancet Neurol*. 2006;5:64–74.
- Boussageon R, Bejan-Angoulvant T, Saadatian-Elahi M, et al. Effect of intensive glucose lowering treatment on all cause mortality, cardiovascular death, and microvascular events in type 2 diabetes: meta-analysis of randomised controlled trials. *BMJ*. 2011;343:d4169.
- Brownlee M. Biochemistry and molecular cell biology of diabetic complications. *Nature*. 2001;414:813–20.
- Buse MG. Hexosamines, insulin resistance, and the complications of diabetes: current status. *Am J Physiol Endocrinol Metab*. 2006;290:E1–8.
- Calvin AD, Aggarwal NR, Murad MH, et al. Aspirin for the primary prevention of cardiovascular events: a systematic review and meta-analysis comparing patients with and without diabetes. *Diabetes Care*. 2009;32:2300–6.
- Camici GG, Schiavoni M, Francia P, et al. Genetic deletion of p66(Shc) adaptor protein prevents hyperglycemia-induced endothelial dysfunction and oxidative stress. *Proc Natl Acad Sci USA*. 2007;104:5217–22.
- Cannon CP, Braunwald E, McCabe CH, et al. Intensive versus moderate lipid lowering with statins after acute coronary syndromes. *N Engl J Med*. 2004;350:1495–504.
- Chakrabarti S, Cukiernik M, Hileeto D, Evans T, Chen S. Role of vasoactive factors in the pathogenesis of early changes in diabetic retinopathy. *Diabetes Metab Res Rev*. 2000;16:393–407.
- Chang CH, Chang YC, Lin JW, Chen ST, Chuang LM, Lai MS. Cardiovascular risk associated with acarbose versus metformin as the first-line treatment in patients with type 2 diabetes: a nationwide cohort study. *J Clin Endocrinol Metab*. 2015;100:1121–9.

- Chiasson JL, Josse RG, Gomis R, et al. Acarbose for prevention of type 2 diabetes mellitus: the STOP-NIDDM randomised trial. *Lancet*. 2002;359:2072–7.
- Cholerton B, Baker LD, Craft S. Insulin resistance and pathological brain ageing. *Diabet Med*. 2011;28:1463–75.
- Cholesterol Treatment Trialists Collaborators, Kearney PM, Blackwell L, et al. Efficacy of cholesterol-lowering therapy in 18,686 people with diabetes in 14 randomised trials of statins: a meta-analysis. *Lancet*. 2008;371:117–25.
- Cleary PA, Orchard TJ, Genuth S, et al. The effect of intensive glycaemic treatment on coronary artery calcification in type 1 diabetic participants of the diabetes control and complications trial/epidemiology of diabetes interventions and complications (DCCT/EDIC) study. *Diabetes*. 2006;55:3556–65.
- Colhoun HM, Betteridge DJ, Durrington PN, et al. Primary prevention of cardiovascular disease with atorvastatin in type 2 diabetes in the Collaborative Atorvastatin Diabetes Study (CARDS): multicentre randomised placebo-controlled trial. *Lancet*. 2004;364:685–96.
- Collins R, Armitage J, Parish S, Sleight P, Peto R, Heart Protection Study Collaborative G. MRC/BHF Heart Protection Study of cholesterol-lowering with simvastatin in 5963 people with diabetes: a randomised placebo-controlled trial. *Lancet*. 2003;361:2005–16.
- Correia SC, Santos RX, Carvalho C, et al. Insulin signaling, glucose metabolism and mitochondria: major players in Alzheimer's disease and diabetes interrelation. *Brain Res*. 2012;1441:64–78.
- Cosentino F, Hishikawa K, Katusic ZS, Luscher TF. High glucose increases nitric oxide synthase expression and superoxide anion generation in human aortic endothelial cells. *Circulation*. 1997;96:25–8.
- Cosentino F, Francia P, Camici GG, Pelicci PG, Luscher TF, Volpe M. Final common molecular pathways of aging and cardiovascular disease: role of the p66Shc protein. *Arterioscler Thromb Vasc Biol*. 2008;28:622–8.
- Criqui MH. Peripheral arterial disease – epidemiological aspects. *Vasc Med*. 2001;6:3–7.
- Criqui MH, Aboyans V. Epidemiology of peripheral artery disease. *Circ Res*. 2015;116:1509–26.
- Currie CJ, Poole CD, Evans M, Peters JR, Morgan CL. Mortality and other important diabetes-related outcomes with insulin vs other antihyperglycemic therapies in type 2 diabetes. *J Clin Endocrinol Metab*. 2013;98:668–77.
- Davidson M, Meyer PM, Haffner S, et al. Increased high-density lipoprotein cholesterol predicts the pioglitazone-mediated reduction of carotid intima-media thickness progression in patients with type 2 diabetes mellitus. *Circulation*. 2008;117:2123–30.
- De Berardis G, Sacco M, Strippoli GF, et al. Aspirin for primary prevention of cardiovascular events in people with diabetes: meta-analysis of randomised controlled trials. *BMJ*. 2009;339:b4531.
- de Jager J, Kooy A, Schalkwijk C, et al. Long-term effects of metformin on endothelial function in type 2 diabetes: a randomized controlled trial. *J Intern Med*. 2014;275:59–70.
- DeFronzo RA. Insulin resistance, lipotoxicity, type 2 diabetes and atherosclerosis: the missing links. The Claude Bernard Lecture 2009. *Diabetologia*. 2010;53:1270–87.
- Del Prato S, Pulizzi N. The place of sulfonylureas in the therapy for type 2 diabetes mellitus. *Metabolism*. 2006;55:S20–7.
- Domanski M, Krause-Steinrauf H, Deedwania P, et al. The effect of diabetes on outcomes of patients with advanced heart failure in the BEST trial. *J Am Coll Cardiol*. 2003;42:914–22.
- Dormandy JA, Charbonnel B, Eckland DJ, et al. Secondary prevention of macrovascular events in patients with type 2 diabetes in the PROactive Study (PROspective pioglitAzone clinical trial in macroVascular events): a randomised controlled trial. *Lancet*. 2005;366:1279–89.
- Duckworth W, Abraira C, Moritz T, et al. Glucose control and vascular complications in veterans with type 2 diabetes. *N Engl J Med*. 2009;360:129–39.
- Effect of intensive blood-glucose control with metformin on complications in overweight patients with type 2 diabetes (UKPDS 34). UK Prospective Diabetes Study (UKPDS) Group. *Lancet*. 1998;352:854–65.
- Eldor R, DeFronzo RA, Abdul-Ghani M. In vivo actions of peroxisome proliferator-activated receptors: glycaemic control, insulin sensitivity, and insulin secretion. *Diabetes Care*. 2013;36 (Suppl 2):S162–74.

- Emerging Risk Factors C, Sarwar N, Gao P, et al. Diabetes mellitus, fasting blood glucose concentration, and risk of vascular disease: a collaborative meta-analysis of 102 prospective studies. *Lancet*. 2010;375:2215–22.
- Erdmann E, Dormandy JA, Charbonnel B, et al. The effect of pioglitazone on recurrent myocardial infarction in 2,445 patients with type 2 diabetes and previous myocardial infarction: results from the PROactive (PROactive 05) Study. *J Am Coll Cardiol*. 2007;49:1772–80.
- Evans JM, Ogston SA, Emslie-Smith A, Morris AD. Risk of mortality and adverse cardiovascular outcomes in type 2 diabetes: a comparison of patients treated with sulfonylureas and metformin. *Diabetologia*. 2006;49:930–6.
- Exalto LG, Whitmer RA, Kappelle LJ, Biessels GJ. An update on type 2 diabetes, vascular dementia and Alzheimer's disease. *Exp Gerontol*. 2012;47:858–64.
- Fadini GP. A reappraisal of the role of circulating (progenitor) cells in the pathobiology of diabetic complications. *Diabetologia*. 2014;57:4–15.
- Fadini GP, Sartore S, Albiero M, et al. Number and function of endothelial progenitor cells as a marker of severity for diabetic vasculopathy. *Arterioscler Thromb Vasc Biol*. 2006;26:2140–6.
- Fadini GP, de Kreutzenberg S, Agostini C, et al. Low CD34+ cell count and metabolic syndrome synergistically increase the risk of adverse outcomes. *Atherosclerosis*. 2009;207:213–9.
- Fadini GP, Albiero M, Menegazzo L, et al. The redox enzyme p66Shc contributes to diabetes and ischemia-induced delay in cutaneous wound healing. *Diabetes*. 2010;59:2306–14.
- Fadini GP, Bonora BM, Cappellari R, et al. Acute effects of linagliptin on progenitor cells, monocyte phenotypes, and soluble mediators in type 2 diabetes. *J Clin Endocrinol Metab*. 2015;101(2):748–56.
- Farmer DG, Kennedy S. RAGE, vascular tone and vascular disease. *Pharmacol Ther*. 2009;124:185–94.
- Feener EP, Xia P, Inoguchi T, Shiba T, Kunisaki M, King GL. Role of protein kinase C in glucose- and angiotensin II-induced plasminogen activator inhibitor expression. *Contrib Nephrol*. 1996;118:180–7.
- Ferrannini E, DeFronzo RA. Impact of glucose-lowering drugs on cardiovascular disease in type 2 diabetes. *Eur Heart J*. 2015;36:2288–96.
- Ferrannini E, Solini A. SGLT2 inhibition in diabetes mellitus: rationale and clinical prospects. *Nat Rev Endocrinol*. 2012;8:495–502.
- Ferri C, Pittoni V, Piccoli A, et al. Insulin stimulates endothelin-1 secretion from human endothelial cells and modulates its circulating levels in vivo. *J Clin Endocrinol Metab*. 1995;80:829–35.
- Fox CS, Golden SH, Anderson C, et al. Update on prevention of cardiovascular disease in adults with type 2 diabetes mellitus in light of recent evidence: a scientific statement from the American Heart Association and the American Diabetes Association. *Circulation*. 2015;132:691–718.
- Francis GS. Diabetic cardiomyopathy: fact or fiction? *Heart*. 2001;85:247–8.
- Frantzen J, Speel TG, Kiemeny LA, Meuleman EJ. Cardiovascular risk among men seeking help for erectile dysfunction. *Ann Epidemiol*. 2006;16:85–90.
- Frederich R, Alexander JH, Fiedorek FT, et al. A systematic assessment of cardiovascular outcomes in the saxagliptin drug development program for type 2 diabetes. *Postgrad Med*. 2010;122:16–27.
- Fukumoto H, Naito Z, Asano G, Aramaki T. Immunohistochemical and morphometric evaluations of coronary atherosclerotic plaques associated with myocardial infarction and diabetes mellitus. *J Atheroscler Thromb*. 1998;5:29–35.
- Gaede P, Lund-Andersen H, Parving HH, Pedersen O. Effect of a multifactorial intervention on mortality in type 2 diabetes. *N Engl J Med*. 2008;358:580–91.
- Gamble JM, Simpson SH, Eurich DT, Majumdar SR, Johnson JA. Insulin use and increased risk of mortality in type 2 diabetes: a cohort study. *Diabetes Obes Metab*. 2010;12:47–53.
- Gazzaruso C, Giordanetti S, De Amici E, et al. Relationship between erectile dysfunction and silent myocardial ischemia in apparently uncomplicated type 2 diabetic patients. *Circulation*. 2004;110:22–6.
- Giacco F, Brownlee M. Oxidative stress and diabetic complications. *Circ Res*. 2010;107:1058–70.
- Goldin A, Beckman JA, Schmidt AM, Creager MA. Advanced glycation end products: sparking the development of diabetic vascular injury. *Circulation*. 2006;114:597–605.

- Golovchenko I, Goalstone ML, Watson P, Brownlee M, Draznin B. Hyperinsulinemia enhances transcriptional activity of nuclear factor-kappaB induced by angiotensin II, hyperglycemia, and advanced glycosylation end products in vascular smooth muscle cells. *Circ Res.* 2000;87:746–52.
- Gorelick PB. CADASIL: do the clinical and MRI profiles differ for women and men? *Stroke.* 2012;43:8–10.
- Grant PJ. Diabetes mellitus as a prothrombotic condition. *J Intern Med.* 2007;262:157–72.
- Green JB, Bethel MA, Armstrong PW, et al. Effect of Sitagliptin on cardiovascular outcomes in type 2 diabetes. *N Engl J Med.* 2015;373:232–42.
- Grosskopf I, Ringel Y, Charach G, et al. Metformin enhances clearance of chylomicrons and chylomicron remnants in nondiabetic mildly overweight glucose-intolerant subjects. *Diabetes Care.* 1997;20:1598–602.
- ADVANCE Collaborative Group, Patel A, MacMahon S, et al. Intensive blood glucose control and vascular outcomes in patients with type 2 diabetes. *N Engl J Med.* 2008;358:2560–72.
- ACCORD Study Group, Ginsberg HN, Elam MB, et al. Effects of combination lipid therapy in type 2 diabetes mellitus. *N Engl J Med.* 2010;362:1563–74.
- Haffner SM, Lehto S, Ronnemaa T, Pyorala K, Laakso M. Mortality from coronary heart disease in subjects with type 2 diabetes and in nondiabetic subjects with and without prior myocardial infarction. *N Engl J Med.* 1998;339:229–34.
- Hammes HP, Weiss A, Hess S, et al. Modification of vitronectin by advanced glycation alters functional properties in vitro and in the diabetic retina. *Lab Invest.* 1996;75:325–38.
- He J, Ogden LG, Bazzano LA, Vupputuri S, Loria C, Whelton PK. Risk factors for congestive heart failure in US men and women: NHANES I epidemiologic follow-up study. *Arch Intern Med.* 2001;161:996–1002.
- Heart Outcomes Prevention Evaluation Study Investigators. Effects of ramipril on cardiovascular and microvascular outcomes in people with diabetes mellitus: results of the HOPE study and MICRO-HOPE substudy. *Lancet* 2000;355:253–9.
- Holman RR, Paul SK, Bethel MA, Matthews DR, Neil HA. 10-year follow-up of intensive glucose control in type 2 diabetes. *N Engl J Med.* 2008;359:1577–89.
- Holman RR, Bethel MA, Mentz RJ, et al. Effects of once-weekly Exenatide on cardiovascular outcomes in type 2 diabetes. *N Engl J Med.* 2017;377(13):1228–39.
- Hong J, Zhang Y, Lai S, et al. Effects of metformin versus glipizide on cardiovascular outcomes in patients with type 2 diabetes and coronary artery disease. *Diabetes Care.* 2013;36:1304–11.
- Inoguchi T, Xia P, Kunisaki M, Higashi S, Feener EP, King GL. Insulin's effect on protein kinase C and diacylglycerol induced by diabetes and glucose in vascular tissues. *Am J Phys.* 1994;267:E369–79.
- Intensive blood-glucose control with sulphonylureas or insulin compared with conventional treatment and risk of complications in patients with type 2 diabetes (UKPDS 33). UK Prospective Diabetes Study (UKPDS) Group. *Lancet* 1998;352:837–53.
- Inzucchi SE, Bergenstal RM, Buse JB, et al. Management of hyperglycemia in type 2 diabetes, 2015: a patient-centered approach: update to a position statement of the American Diabetes Association and the European Association for the Study of Diabetes. *Diabetes Care.* 2015;38:140–9.
- Iso H, Imano H, Kitamura A, et al. Type 2 diabetes and risk of non-embolic ischaemic stroke in Japanese men and women. *Diabetologia.* 2004;47:2137–44.
- James PA, Oparil S, Carter BL, et al. 2014 evidence-based guideline for the management of high blood pressure in adults: report from the panel members appointed to the Eighth Joint National Committee (JNC 8). *JAMA.* 2014;311:507–20.
- Johansen OE, Neubacher D, von Eynatten M, Patel S, Woerle HJ. Cardiovascular safety with linagliptin in patients with type 2 diabetes mellitus: a pre-specified, prospective, and adjudicated meta-analysis of a phase 3 programme. *Cardiovasc Diabetol.* 2012;11:3.
- Johnson JA, Majumdar SR, Simpson SH, Toth EL. Decreased mortality associated with the use of metformin compared with sulfonylurea monotherapy in type 2 diabetes. *Diabetes Care.* 2002;25:2244–8.



- Juutilainen A, Lehto S, Ronnema T, Pyorala K, Laakso M. Retinopathy predicts cardiovascular mortality in type 2 diabetic men and women. *Diabetes Care*. 2007;30:292–9.
- Kalaitzidis R, Bakris G. Pathogenesis and treatment of microalbuminuria in patients with diabetes: the road ahead. *J Clin Hypertens (Greenwich)*. 2009;11:636–43.
- Kanwar YS, Wada J, Sun L, et al. Diabetic nephropathy: mechanisms of renal disease progression. *Exp Biol Med (Maywood)*. 2008a;233:4–11.
- Kanwar M, Almanaseer Y, Alroaini A. When catastrophe strikes – a case of atrial myxoma with distal embolization. *J Invasive Cardiol*. 2008b;20:E314–5.
- Karapanayiotides T, Piechowski-Jozwiak B, van Melle G, Bogousslavsky J, Devuyst G. Stroke patterns, etiology, and prognosis in patients with diabetes mellitus. *Neurology*. 2004;62:1558–62.
- Kass DA, Shapiro EP, Kawaguchi M, et al. Improved arterial compliance by a novel advanced glycation end-product crosslink breaker. *Circulation*. 2001;104:1464–70.
- Keech A, Simes RJ, Barter P, et al. Effects of long-term fenofibrate therapy on cardiovascular events in 9795 people with type 2 diabetes mellitus (the FIELD study): randomised controlled trial. *Lancet*. 2005;366:1849–61.
- Khan KN, Khan MH, Haque MZ. Correlation between microalbuminuria with complexity of coronary artery disease in diabetic patients. *Mymensingh Med J*. 2013;22:353–7.
- Khoury JC, Kleindorfer D, Alwell K, et al. Diabetes mellitus: a risk factor for ischemic stroke in a large biracial population. *Stroke*. 2013;44:1500–4.
- Klepzig H, Kober G, Matter C, et al. Sulfonylureas and ischaemic preconditioning; a double-blind, placebo-controlled evaluation of glimepiride and glibenclamide. *Eur Heart J*. 1999;20:439–46.
- Kolm-Litty V, Sauer U, Nerlich A, Lehmann R, Schleicher ED. High glucose-induced transforming growth factor beta1 production is mediated by the hexosamine pathway in porcine glomerular mesangial cells. *J Clin Invest*. 1998;101:160–9.
- Kuboki K, Jiang ZY, Takahara N, et al. Regulation of endothelial constitutive nitric oxide synthase gene expression in endothelial cells and in vivo: a specific vascular action of insulin. *Circulation*. 2000;101:676–81.
- LaRosa JC, Grundy SM, Waters DD, et al. Intensive lipid lowering with atorvastatin in patients with stable coronary disease. *N Engl J Med*. 2005;352:1425–35.
- Liew G, Wong TY, Mitchell P, Cheung N, Wang JJ. Retinopathy predicts coronary heart disease mortality. *Heart*. 2009;95:391–4.
- Lindholm LH, Ibsen H, Dahlof B, et al. Cardiovascular morbidity and mortality in patients with diabetes in the losartan intervention for endpoint reduction in hypertension study (LIFE): a randomised trial against atenolol. *Lancet*. 2002;359:1004–10.
- Lonborg J, Vejstrup N, Kelbaek H, et al. Exenatide reduces reperfusion injury in patients with ST-segment elevation myocardial infarction. *Eur Heart J*. 2012;33:1491–9.
- MacDonald MR, Petrie MC, Hawkins NM, et al. Diabetes, left ventricular systolic dysfunction, and chronic heart failure. *Eur Heart J*. 2008;29:1224–40.
- Madonna R, De Caterina R. Cellular and molecular mechanisms of vascular injury in diabetes – part I: pathways of vascular disease in diabetes. *Vasc Pharmacol*. 2011;54:68–74.
- Manolio TA, Kronmal RA, Burke GL, O’Leary DH, Price TR. Short-term predictors of incident stroke in older adults. The Cardiovascular Health Study. *Stroke*. 1996;27:1479–86.
- Marso SP, Daniels GH, Brown-Frandsen K, et al. Liraglutide and cardiovascular outcomes in type 2 diabetes. *N Engl J Med*. 2016a;375:311–22.
- Marso SP, Bain SC, Consoli A, et al. Semaglutide and cardiovascular outcomes in patients with type 2 diabetes. *N Engl J Med*. 2016b;375:1834–44.
- Martens FM, Visseren FL, de Koning EJ, Rabelink TJ. Short-term pioglitazone treatment improves vascular function irrespective of metabolic changes in patients with type 2 diabetes. *J Cardiovasc Pharmacol*. 2005;46:773–8.
- Maruyama S, Taguchi A, Iwashima S, et al. Low circulating CD34+ cell count is associated with poor prognosis in chronic hemodialysis patients. *Kidney Int*. 2008;74:1603–9.

- Matsubara J, Sugiyama S, Akiyama E, et al. Dipeptidyl peptidase-4 inhibitor, sitagliptin, improves endothelial dysfunction in association with its anti-inflammatory effects in patients with coronary artery disease and uncontrolled diabetes. *Circ J*. 2013;77:1337–44.
- Mazzone T, Meyer PM, Feinstein SB, et al. Effect of pioglitazone compared with glimepiride on carotid intima-media thickness in type 2 diabetes: a randomized trial. *JAMA*. 2006;296:2572–81.
- McBrien K, Rabi DM, Campbell N, et al. Intensive and standard blood pressure targets in patients with type 2 diabetes mellitus: systematic review and meta-analysis. *Arch Intern Med*. 2012;172:1296–303.
- McVeigh GE, Brennan GM, Johnston GD, et al. Impaired endothelium-dependent and independent vasodilation in patients with type 2 (non-insulin-dependent) diabetes mellitus. *Diabetologia*. 1992;35:771–6.
- Meena BL, Kochar DK, Agarwal TD, Choudhary R, Kochar A. Association between erectile dysfunction and cardiovascular risk in individuals with type-2 diabetes without overt cardiovascular disease. *Int J Diabetes Dev Ctries*. 2009;29(4):150.
- Meinert CL, Knatterud GL, Prout TE, Klimt CR. A study of the effects of hypoglycemic agents on vascular complications in patients with adult-onset diabetes. II. Mortality results. *Diabetes*. 1970;19(Suppl):789–830.
- Miettinen H, Haffner SM, Lehto S, Ronnema T, Pyorala K, Laakso M. Retinopathy predicts coronary heart disease events in NIDDM patients. *Diabetes Care*. 1996;19:1445–8.
- Monami M, Genovese S, Mannucci E. Cardiovascular safety of sulfonylureas: a meta-analysis of randomized clinical trials. *Diabetes Obes Metab*. 2013;15:938–53.
- Monhart V. Microalbuminuria. From diabetes to cardiovascular risk. *Vnitr Lek*. 2011;57:293–8.
- Montagnani M, Golovchenko I, Kim I, et al. Inhibition of phosphatidylinositol 3-kinase enhances mitogenic actions of insulin in endothelial cells. *J Biol Chem*. 2002;277:1794–9.
- Moran C, Phan TG, Chen J, et al. Brain atrophy in type 2 diabetes: regional distribution and influence on cognition. *Diabetes Care*. 2013;36:4036–42.
- Morbach S, Furchert H, Grobblinghoff U, et al. Long-term prognosis of diabetic foot patients and their limbs: amputation and death over the course of a decade. *Diabetes Care*. 2012;35:2021–7.
- Morgan CL, Mukherjee J, Jenkins-Jones S, Holden SE, Currie CJ. Association between first-line monotherapy with sulphonylurea versus metformin and risk of all-cause mortality and cardiovascular events: a retrospective, observational study. *Diabetes Obes Metab*. 2014;16:957–62.
- Morrish NJ, Wang SL, Stevens LK, Fuller JH, Keen H. Mortality and causes of death in the WHO Multinational Study of Vascular Disease in Diabetes. *Diabetologia*. 2001;44(Suppl 2):S14–21.
- Mottillo S, Filion KB, Genest J, et al. The metabolic syndrome and cardiovascular risk a systematic review and meta-analysis. *J Am Coll Cardiol*. 2010;56:1113–32.
- Nagi DK, Yudkin JS. Effects of metformin on insulin resistance, risk factors for cardiovascular disease, and plasminogen activator inhibitor in NIDDM subjects. A study of two ethnic groups. *Diabetes Care*. 1993;16:621–9.
- Nathan DM, Lachin J, Cleary P, et al. Intensive diabetes therapy and carotid intima-media thickness in type 1 diabetes mellitus. *N Engl J Med*. 2003;348:2294–303.
- Nathan DM, Cleary PA, Backlund JY, et al. Intensive diabetes treatment and cardiovascular disease in patients with type 1 diabetes. *N Engl J Med*. 2005;353:2643–53.
- Ndip A, Jude EB. Emerging evidence for neuroischemic diabetic foot ulcers: model of care and how to adapt practice. *Int J Low Extrem Wounds*. 2009;8:82–94.
- Neal B, Perkovic V, Mahaffey KW, et al. Canagliflozin and cardiovascular and renal events in type 2 diabetes. *N Engl J Med*. 2017;377:644–57.
- Negre-Salvayre A, Salvayre R, Auge N, Pamplona R, Portero-Otin M. Hyperglycemia and glycation in diabetic complications. *Antioxid Redox Signal*. 2009;11:3071–109.
- Nicholls SJ, Tuzcu EM, Wolski K, et al. Lowering the triglyceride/high-density lipoprotein cholesterol ratio is associated with the beneficial impact of pioglitazone on progression of coronary atherosclerosis in diabetic patients: insights from the PERISCOPE (pioglitazone effect

- on regression of intravascular Sonographic coronary obstruction prospective evaluation) study. *J Am Coll Cardiol.* 2011;57:153–9.
- Nikolaidis LA, Mankad S, Sokos GG, et al. Effects of glucagon-like peptide-1 in patients with acute myocardial infarction and left ventricular dysfunction after successful reperfusion. *Circulation.* 2004;109:962–5.
- Nilsson PM, Cederholm J, Zethelius BR, Eliasson BR, Eeg-Olofsson K, Gudbj Rnsdottir S. Trends in blood pressure control in patients with type 2 diabetes: data from the Swedish National Diabetes Register (NDR). *Blood Press.* 2011;20:348–54.
- O'Donnell MJ, Xavier D, Liu L, et al. Risk factors for ischaemic and intracerebral haemorrhagic stroke in 22 countries (the INTERSTROKE study): a case-control study. *Lancet.* 2010;376:112–23.
- Oliver FJ, de la Rubia G, Feener EP, et al. Stimulation of endothelin-1 gene expression by insulin in endothelial cells. *J Biol Chem.* 1991;266:23251–6.
- Origin Trial Investigators, Gerstein HC, Bosch J, et al. Basal insulin and cardiovascular and other outcomes in dysglycemia. *N Engl J Med.* 2012;367:319–28.
- Ott A, Stolk RP, van Harskamp F, Pols HA, Hofman A, Breteler MM. Diabetes mellitus and the risk of dementia: the Rotterdam Study. *Neurology.* 1999;53:1937–42.
- Pandolfi A, Cetrullo D, Polishuck R, et al. Plasminogen activator inhibitor type 1 is increased in the arterial wall of type II diabetic subjects. *Arterioscler Thromb Vasc Biol.* 2001;21:1378–82.
- Paneni F, Mocharla P, Akhmedov A, et al. Gene silencing of the mitochondrial adaptor p66(Shc) suppresses vascular hyperglycemic memory in diabetes. *Circ Res.* 2012;111:278–89.
- Patel RS, Li Q, Ghasemzadeh N, et al. Circulating CD34+ progenitor cells and risk of mortality in a population with coronary artery disease. *Circ Res.* 2015;116:289–97.
- Pedersen TR, Faergeman O, Kastelein JJ, et al. High-dose atorvastatin vs usual-dose simvastatin for secondary prevention after myocardial infarction: the IDEAL study: a randomized controlled trial. *JAMA.* 2005;294:2437–45.
- Peila R, Rodriguez BL, Launer LJ, Honolulu-Asia Aging S. Type 2 diabetes, APOE gene, and the risk for dementia and related pathologies: the Honolulu-Asia Aging Study. *Diabetes.* 2002;51:1256–62.
- Pfeffer MA, Claggett B, Diaz R, et al. Lixisenatide in patients with type 2 diabetes and acute coronary syndrome. *N Engl J Med.* 2015;373:2247–57.
- Pignone M, Earnshaw S, Tice JA, Pletcher MJ. Aspirin, statins, or both drugs for the primary prevention of coronary heart disease events in men: a cost-utility analysis. *Ann Intern Med.* 2006;144:326–36.
- Pignone M, Earnshaw S, Pletcher MJ, Tice JA. Aspirin for the primary prevention of cardiovascular disease in women: a cost-utility analysis. *Arch Intern Med.* 2007;167:290–5.
- Poornima IG, Parikh P, Shannon RP. Diabetic cardiomyopathy: the search for a unifying hypothesis. *Circ Res.* 2006;98:596–605.
- Ptaszynska A, Hardy E, Johnsson E, Parikh S, List J. Effects of dapagliflozin on cardiovascular risk factors. *Postgrad Med.* 2013;125:181–9.
- Rana A, Goyal N, Ahlawat A, Jamwal S, Reddy BV, Sharma S. Mechanisms involved in attenuated cardio-protective role of ischemic preconditioning in metabolic disorders. *Perfusion.* 2015;30:94–105.
- Reddy KJ, Singh M, Bangit JR, Batsell RR. The role of insulin resistance in the pathogenesis of atherosclerotic cardiovascular disease: an updated review. *J Cardiovasc Med (Hagerstown).* 2010;11:633–47.
- Redon J, Cifkova R, Laurent S, et al. Mechanisms of hypertension in the cardiometabolic syndrome. *J Hypertens.* 2009;27:441–51.
- Reinhard H, Wiinberg N, Hansen PR, et al. NT-proBNP levels, atherosclerosis and vascular function in asymptomatic type 2 diabetic patients with microalbuminuria: peripheral reactive hyperaemia index but not NT-proBNP is an independent predictor of coronary atherosclerosis. *Cardiovasc Diabetol.* 2011;10:71.
- Richter B, Bandeira-Echtler E, Bergerhoff K, Lerch CL. Dipeptidyl peptidase-4 (DPP-4) inhibitors for type 2 diabetes mellitus. *Cochrane Database Syst Rev.* 2008;16(2):CD006739.

- Ridray S. Hyperinsulinemia and smooth muscle cell proliferation. *Int J Obes Relat Metab Disord*. 1995;19(Suppl 1):S39–51.
- Rigato M, Fadini GP. Comparative effectiveness of liraglutide in the treatment of type 2 diabetes. *Diabetes Metab Syndr Obes*. 2014;7:107–20.
- Rigato M, Bittante C, Albiero M, Avogaro A, Fadini GP. Circulating progenitor cell count predicts microvascular outcomes in type 2 diabetic patients. *J Clin Endocrinol Metab*. 2015;100:2666–72.
- Rigato M, Monami M, Fadini GP. Autologous cell therapy for peripheral arterial disease: systematic review and meta-analysis of randomized, nonrandomized, and noncontrolled studies. *Circ Res*. 2017;120:1326–40.
- Rikitake Y, Liao JK. Rho-kinase mediates hyperglycemia-induced plasminogen activator inhibitor-1 expression in vascular endothelial cells. *Circulation*. 2005;111:3261–8.
- Rong J, Yu CQ, Yang P, Chen J. Association of retinopathy with coronary atherosclerosis determined by coronary 64-slice multidetector computed tomography angiography in type 2 diabetes. *Diab Vasc Dis Res*. 2013;10:161–8.
- Rossing P, Hougaard P, Borch-Johnsen K, Parving HH. Predictors of mortality in insulin dependent diabetes: 10 year observational follow up study. *BMJ*. 1996;313:779–84.
- Roumie CL, Hung AM, Greevy RA, et al. Comparative effectiveness of sulfonylurea and metformin monotherapy on cardiovascular events in type 2 diabetes mellitus: a cohort study. *Ann Intern Med*. 2012;157:601–10.
- Ruggenti P, Fassi A, Ilieva AP, et al. Preventing microalbuminuria in type 2 diabetes. *N Engl J Med*. 2004;351:1941–51.
- Sarafidis PA, Nilsson PM. The effects of thiazolidinediones on blood pressure levels – a systematic review. *Blood Press*. 2006;15:135–50.
- Schmidt AM, Hori O, Brett J, Yan SD, Wautier JL, Stern D. Cellular receptors for advanced glycation end products. Implications for induction of oxidant stress and cellular dysfunction in the pathogenesis of vascular lesions. *Arterioscler Thromb*. 1994;14:1521–8.
- Schmidt-Lucke C, Rossig L, Fichtlscherer S, et al. Reduced number of circulating endothelial progenitor cells predicts future cardiovascular events: proof of concept for the clinical importance of endogenous vascular repair. *Circulation*. 2005;111:2981–7.
- Schneider J, Erren T, Zofel P, Kaffarnik H. Metformin-induced changes in serum lipids, lipoproteins, and apoproteins in non-insulin-dependent diabetes mellitus. *Atherosclerosis*. 1990;82:97–103.
- Schramm TK, Gislason GH, Vaag A, et al. Mortality and cardiovascular risk associated with different insulin secretagogues compared with metformin in type 2 diabetes, with or without a previous myocardial infarction: a nationwide study. *Eur Heart J*. 2011;32:1900–8.
- Schweizer A, DeJager S, Foley JE, Couturier A, Ligueros-Saylan M, Kothny W. Assessing the cardio-cerebrovascular safety of vildagliptin: meta-analysis of adjudicated events from a large phase III type 2 diabetes population. *Diabetes Obes Metab*. 2010;12:485–94.
- Scirica BM, Bhatt DL, Braunwald E, et al. Saxagliptin and cardiovascular outcomes in patients with type 2 diabetes mellitus. *N Engl J Med*. 2013;369:1317–26.
- Scott A, Schurer S, Jensen PH, Sivey P. The effects of an incentive program on quality of care in diabetes management. *Health Econ*. 2009;18:1091–108.
- Shah AD, Langenberg C, Rapsomaniki E, et al. Type 2 diabetes and incidence of cardiovascular diseases: a cohort study in 1.9 million people. *Lancet Diabetes Endocrinol*. 2015;3:105–13.
- Sibal L, Aldibbiat A, Agarwal SC, et al. Circulating endothelial progenitor cells, endothelial function, carotid intima-media thickness and circulating markers of endothelial dysfunction in people with type 1 diabetes without macrovascular disease or microalbuminuria. *Diabetologia*. 2009;52:1464–73.
- Soedamah-Muthu SS, Colhoun HM, Abrahamian H, et al. Trends in hypertension management in type I diabetes across Europe, 1989/1990–1997/1999. *Diabetologia*. 2002;45:1362–71.
- Sokos GG, Nikolaidis LA, Mankad S, Elahi D, Shannon RP. Glucagon-like peptide-1 infusion improves left ventricular ejection fraction and functional status in patients with chronic heart failure. *J Card Fail*. 2006;12(9):694.

- Stout RW. Insulin stimulation of cholesterol synthesis by arterial tissue. *Lancet*. 1969;2:467–8.
- Stratton IM, Adler AI, Neil HA, et al. Association of glycaemia with macrovascular and microvascular complications of type 2 diabetes (UKPDS 35): prospective observational study. *BMJ*. 2000;321:405–12.
- Studer RK, Craven PA, DeRubertis FR. Role for protein kinase C in the mediation of increased fibronectin accumulation by mesangial cells grown in high-glucose medium. *Diabetes*. 1993;42:118–26.
- Suzuki LA, Poot M, Gerrity RG, Bornfeldt KE. Diabetes accelerates smooth muscle accumulation in lesions of atherosclerosis: lack of direct growth-promoting effects of high glucose levels. *Diabetes*. 2001;50:851–60.
- Suzuki M, Akimoto K, Hattori Y. Glucose upregulates plasminogen activator inhibitor-1 gene expression in vascular smooth muscle cells. *Life Sci*. 2002;72:59–66.
- Tan KC, Chow WS, Ai VH, Metz C, Bucala R, Lam KS. Advanced glycation end products and endothelial dysfunction in type 2 diabetes. *Diabetes Care*. 2002;25:1055–9.
- Tayek J. SUR receptor activity vs. incidence of hypoglycaemia and cardiovascular mortality with sulphonylurea therapy for diabetics. *Diabetes Obes Metab*. 2008;10:1128–9. Author reply 9–30.
- The BIP Study Group. Secondary Prevention by Raising HDL Cholesterol and Reducing Triglycerides in Patients With Coronary Artery Disease: The Bezafibrate Infarction Prevention (BIP) Study. *Circulation*. 2000;102(1):21–27.
- Thompson IM, Tangen CM, Goodman PJ, Probstfield JL, Moinpour CM, Coltman CA. Erectile dysfunction and subsequent cardiovascular disease. *JAMA*. 2005;294:2996–3002.
- U.S. Food and Drug Administration. FDA Drug Safety Communication: updated risk evaluation and mitigation strategy (REMS) to restrict access to rosiglitazone-containing medicines including Avandia, Avandamet, and Avandaryl. 2011. <http://www.fda.gov/Drugs/DrugSafety/ucm255005.htm> (24 February 2015).
- Uemura S, Matsushita H, Li W, et al. Diabetes mellitus enhances vascular matrix metalloproteinase activity: role of oxidative stress. *Circ Res*. 2001;88:1291–8.
- Vaccaro O, Masulli M, Nicolucci A et al., For the Thiazolidinediones Or Sulfonylureas Cardiovascular Accidents Intervention Trial (TOSCA.IT) Study Group, et al. Effects on the incidence of cardiovascular events of the addition of pioglitazone versus sulfonylureas in patients with type 2 diabetes inadequately controlled with metformin (TOSCA.IT): a randomised, multicentre trial. *Lancet Diabetes Endocrinol*. 2017;5(11):887–97.
- Valensi P, Lorgis L, Cottin Y. Prevalence, incidence, predictive factors and prognosis of silent myocardial infarction: a review of the literature. *Arch Cardiovasc Dis*. 2011;104:178–88.
- Vaur L, Gueret P, Lievre M, Chabaud S, Passa P, study DSG. Development of congestive heart failure in type 2 diabetic patients with microalbuminuria or proteinuria: observations from the DIABHYCAR (type 2 DIABetes, Hypertension, Cardiovascular Events and Ramipril) study. *Diabetes Care*. 2003;26:855–60.
- Veitenhansl M, Stegner K, Hierl FX, et al. 40th EASD annual meeting of the European Association for the Study of Diabetes: Munich, Germany, 5–9 September 2004. *Diabetologia*. 2004;47:A1–A464.
- Vinik AI, Erbas T, Park TS, Nolan R, Pittenger GL. Platelet dysfunction in type 2 diabetes. *Diabetes Care*. 2001;24:1476–85.
- Wautier MP, Chappey O, Corda S, Stern DM, Schmidt AM, Wautier JL. Activation of NADPH oxidase by AGE links oxidant stress to altered gene expression via RAGE. *Am J Physiol Endocrinol Metab*. 2001;280:E685–94.
- Wendt T, Bucciarelli L, Qu W, et al. Receptor for advanced glycation endproducts (RAGE) and vascular inflammation: insights into the pathogenesis of macrovascular complications in diabetes. *Curr Atheroscler Rep*. 2002;4:228–37.
- Werner N, Kosiol S, Schiegl T, et al. Circulating endothelial progenitor cells and cardiovascular outcomes. *N Engl J Med*. 2005;353:999–1007.
- White WB, Cannon CP, Heller SR, et al. Alogliptin after acute coronary syndrome in patients with type 2 diabetes. *N Engl J Med*. 2013;369:1327–35.

- Wilcox R, Bousser MG, Betteridge DJ, et al. Effects of pioglitazone in patients with type 2 diabetes with or without previous stroke: results from PROactive (PROspective pioglitAzone Clinical Trial In macroVascular Events 04). *Stroke*. 2007;38:865–73.
- Williams SB, Cusco JA, Roddy MA, Johnstone MT, Creager MA. Impaired nitric oxide-mediated vasodilation in patients with non-insulin-dependent diabetes mellitus. *J Am Coll Cardiol*. 1996;27:567–74.
- Williams-Herman D, Engel SS, Round E, et al. Safety and tolerability of sitagliptin in clinical studies: a pooled analysis of data from 10,246 patients with type 2 diabetes. *BMC Endocr Disord*. 2010;10:7.
- Wolf PA, D'Agostino RB, Belanger AJ, Kannel WB. Probability of stroke: a risk profile from the Framingham Study. *Stroke*. 1991;22:312–8.
- Xia P, Inoguchi T, Kern TS, Engerman RL, Oates PJ, King GL. Characterization of the mechanism for the chronic activation of diacylglycerol-protein kinase C pathway in diabetes and hypergalactosemia. *Diabetes*. 1994;43(9):1122.
- Yan SF, Ramasamy R, Schmidt AM. The RAGE axis: a fundamental mechanism signaling danger to the vulnerable vasculature. *Circ Res*. 2010;106:842–53.
- Yerneni KK, Bai W, Khan BV, Medford RM, Natarajan R. Hyperglycemia-induced activation of nuclear transcription factor kappaB in vascular smooth muscle cells. *Diabetes*. 1999;48:855–64.
- Young LH, Wackers FJ, Chyun DA, et al. Cardiac outcomes after screening for asymptomatic coronary artery disease in patients with type 2 diabetes: the DIAD study: a randomized controlled trial. *JAMA*. 2009;301:1547–55.
- Zeng G, Nystrom FH, Ravichandran LV, et al. Roles for insulin receptor, PI3-kinase, and Akt in insulin-signaling pathways related to production of nitric oxide in human vascular endothelial cells. *Circulation*. 2000;101:1539–45.
- Zinman B, Wanner C, Lachin JM, et al. Empagliflozin, cardiovascular outcomes, and mortality in type 2 diabetes. *N Engl J Med*. 2015;373:2117–28.



# Pathogenesis of Microvascular Complications

# 6

Mogher Khamaisi, George L. King, Kyoungmin Park, and Qian Li

## Contents

Introduction .....	162
Role of the Polyol Pathway .....	166
The Role of the Glycation Modification of Proteins in Diabetic Microvascular Complications .....	168
Oxidative Stress in the Pathogenesis of Diabetic Microvascular Complications .....	169
Activation of Protein Kinase C in Vascular Tissues .....	171
Evidence for the Activation of Diacylglycerol (DAG)-PKC Pathway in Diabetes .....	172
PKC Activation in the Development of Diabetic Nephropathy .....	173
Clinical Studies Using RBX for Treatment of DN .....	173
PKC Activation in the Development of Diabetic Retinopathy .....	174
Role of PKC in the Development of Diabetic Peripheral Neuropathy (DPN) .....	175
PKC $\delta$ Activation in Fibroblasts and Wound Healing .....	176
Renin-Angiotensin System (RAS) in the Pathogenesis of Diabetic Microvascular Complications .....	177
Role of Endoplasmic Reticulum (ER) Stress in Diabetic Microvascular Complications .....	178
Role of Kallikrein-Bradykinin System in the Development of Diabetic Microvascular Complications .....	178
Role of the Kallikrein-Kinin System in Diabetic Retinopathy .....	179
Protective Factors .....	181
Insulin: Concept of Selective Insulin Resistance on the Vessel Wall in Diabetes .....	181

---

M. Khamaisi

Section of Vascular Cell Biology, Joslin Diabetes Center, Harvard Medical School, Boston, MA, USA

Institutes of Endocrinology, Diabetes and Metabolism and Internal Medicine D, Rambam Health Care Campus and RB Rappaport Faculty of Medicine-Technion, Haifa, Israel

e-mail: [Khamaisi@gmail.com](mailto:Khamaisi@gmail.com)

G. L. King (✉) · K. Park · Q. Li

Section of Vascular Cell Biology, Joslin Diabetes Center, Harvard Medical School, Boston, MA, USA

e-mail: [george.king@joslin.harvard.edu](mailto:george.king@joslin.harvard.edu); [Kyoungmin.park@joslin.harvard.edu](mailto:Kyoungmin.park@joslin.harvard.edu); [qian.li@joslin.harvard.edu](mailto:qian.li@joslin.harvard.edu)

Antioxidant Enzymes .....	183
SHP-1 Activation and Its Inhibitory Effects of PDGF and VEGF .....	184
TGF- $\beta$ .....	186
VEGF .....	186
Activated Protein C (APC) .....	187
Vascular Progenitor Cells (VPC) .....	188
Summary .....	189
References .....	190

### Abstract

Risk factors and protective factors in diabetic microvascular complication.

### Keywords

Advanced glycation end products (AGE) · Reactive oxygen species (ROS) · Protein kinase C (PKC) · Vascular endothelial growth factor (VEGF) · Activated protein C (APC) · Platelet-derived growth factor (PDGF) · Transforming growth factor b (TGF) · Heme oxygenase-1 (HO-1)

## Introduction

Diabetic complications can affect many organs; however, in general they are separated into macro- and microvascular diseases due to differences in risk factors, responses to treatments, and pathological involvement of arteries versus capillaries. The microvascular complications classically include retinopathy (DR), nephropathy (DN), and neuropathy. However, due to recent understandings of the pathogenesis of abnormalities in increased risks of wound healing, cognitive dysfunction or Alzheimer's disease and neoplasm could also be classified as complications of the microvessels in diabetes (Fig. 1). In general, diabetic complications are the results of at least three different categories of factors. They are systemic metabolic abnormalities such as hyperglycemia, dyslipidemia, and insulin resistance. The second category is the role of genetic and epigenetic, for example, only 30% of diabetic patients will experience chronic renal failure (Molitch et al. 2004). The third category is local tissue response. This is clearly documented by the differential expression of vascular endothelial growth factors (VEGF) in response to diabetes, which cause paradoxical increases in angiogenesis in the retina and its decrease in the peripheral limbs and myocardium (Aiello et al. 1994; Chou et al. 2002). In the following, we will provide a general description of the major risk factors that are involved in the microvascular diseases related to diabetes. In the second part, a detailed discussion is given regarding the potential mechanism by which toxic metabolites of hyperglycemia can increase the risk of complications. Then, the discussion will focus on the understanding of protective factors and roles which is clearly very important. All of these factors are important to understand the diverse pathologies of diabetic complications in a variety of tissues as the results of imbalance due to increase in toxic metabolites of hyperglycemia and reduction of protective factors (Rask-Madsen and King 2013) (Fig. 2).



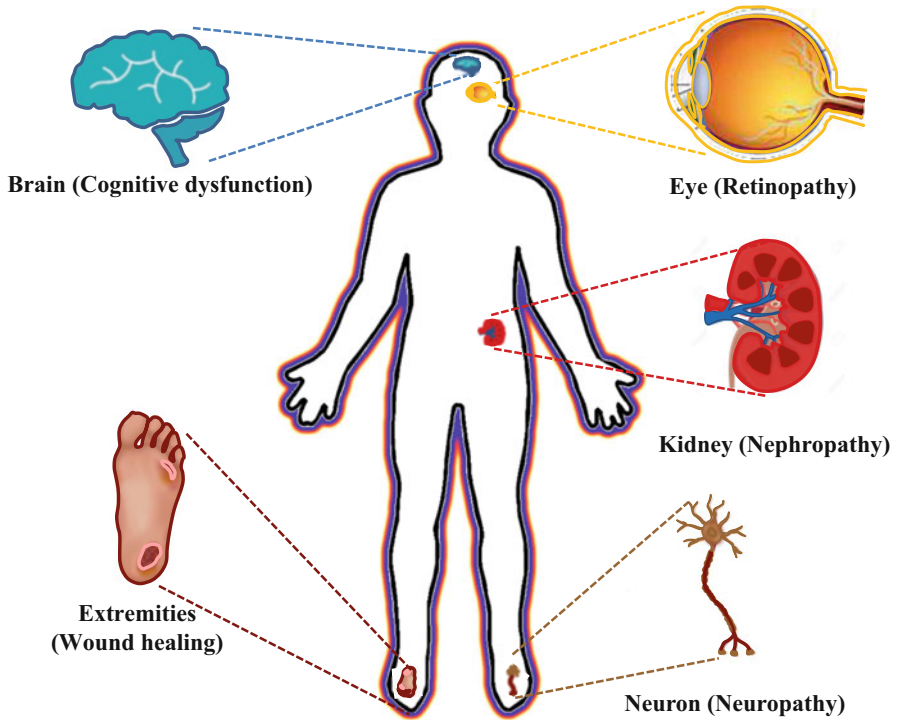

**Fig. 1** Schematic sites of main microvascular complications in diabetes

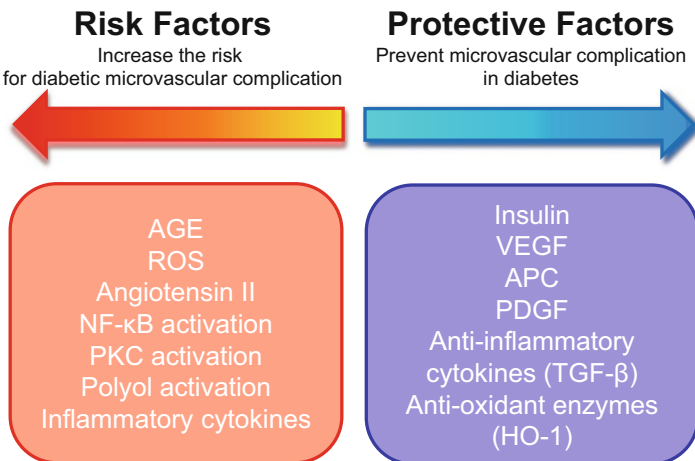

**Fig. 2** Upregulation of risk factors and downregulation of protective factors in diabetic microvascular complication. *AGE* advanced glycation end products, *ROS* reactive oxygen species, *PKC* protein kinase C, *VEGF* vascular endothelial growth factor, *APC* activated protein C, *PDGF* platelet-derived growth factor, *TGF* transforming growth factor b, and *HO-1* heme oxygenase-1

Systemic metabolic factors are clearly the major causal factors for diabetic microvascular diseases. It is the major metabolic dysfunction that is causing microvascular diseases for retinopathy and nephropathy. The results of the Diabetes Control and Complications Trial (DCCT) in type 1 diabetes (T1D) and the United Kingdom Perspective Study (UKPDS) in type 2 diabetes (T2D) have clearly demonstrated that intensive blood glucose control delays the onset and retards the progression of diabetic microvascular complications (DCCT Group 1993). Further, intensive control of hyperglycemia is also helpful to decrease cardiovascular diseases (CVD) in T1D patients (DCCT 2016). In contrast, intensive glycemic control with insulin has not shown a dramatic decrease of CVD in T2D patients (Patel et al. 2008) demonstrating clear differences in the pathogenesis of macro- versus microvascular diseases. The importance of hyperglycemia on microvascular diseases is overwhelming. There is very little evidence that without hyperglycemia such as syndromes of insulin resistance will induce significant risk in the development of DR and DN. The presence of dyslipidemia and insulin resistance probably do not have a major impact on DR and DN, since people with metabolic syndrome and without diagnosis of diabetes have minimal risks for DR and even DN (Keenan et al. 2009; Foster et al. 2008). Thus, it is likely that dyslipidemia and insulin resistance may have additive effects only in the presence of hyperglycemia for DR and DN. Interesting findings from the DCCT and Epidemiology of Diabetes Interventions and Complications (EDIC) have also shown that reversal of hyperglycemia will not rapidly normalize all of the risks of microvascular diseases since after 10 years of intensive glycemic control, the group previously on non-intensive glycemic control continued to experience increased risks for DR and DN, which have led to the concept of metabolic memory (Retinopathy 2000).

**Genetic and epigenetic regulation.** Extensive studies have shown that only 30% of diabetic patients, T1D and T2D, will experience increased risk of renal failure (Molitch et al. 2004). In addition, the risk for DN also has familial cluster, again supporting a genetic and epigenetic role. The risk for DR appears to be also related to familial clusters; however, genetics for DR has been difficult to establish since more than 90% of diabetic patients will have significant DR with prolonged duration of disease (Aiello et al. 1998). The genetic role of microvascular complications has been studied in detail over the last 20 years; however, definitive role and targets have not been established clearly. This has led to interest in studying the pathogenesis for familial clusters and lack of DN in 60–70% of diabetic populations and in those individuals with T1D of extreme duration, 50–80 years of diabetes, could possibly be due to epigenetic changes. The difficulty of identifying genetic factors for the lack of DN/DR in a large group of diabetic patients has given rise to the idea that the development and establishment of vascular complications of diabetes could be an interplay of increased risk factors induced by hyperglycemia and a decrease in the protective mechanisms that are naturally occurring in the tissues. Further discussions on this idea will be provided below.

**Local tissue response.** Differential tissue responses are also critical in the development of microvascular complications. A classic example of the importance of local responses is the paradoxical exhibition of increase in neovascularization in

proliferative diabetic retinopathy (PDR) versus the decrease in capillary density in response to ischemia as exhibited in the peripheral limbs, myocardium, and wound healing process (Aiello et al. 1994; Chou et al. 2002). At the biochemical and molecular levels, differences of angiogenesis are related to changes in VEGF expression which are clearly increased in PDR and decreased VEGF expression in the peripheral tissues, myocardium, and wounds. It is unknown at this time what are the differential mechanisms that are causing the paradoxical changes in VEGF and other factors that lead to differences in the pathologies.

Thus, the clinical and epidemiological information derived from the microvascular complications exhibited by the diabetic individuals have strongly suggested that protective or neutralizing factors exist to prevent or delay the progression of toxicity due to hyperglycemia. For example, the studies by Krolewski et al. have shown that 2/3 of T1D patients who exhibited microalbuminuria do not progress with loss of significant renal function even after 15 years of duration. In fact, 1/3 of these individuals with diabetes have resolution of their microalbuminuria while maintaining their estimated glomerular filtration rate (GFR) in the same time span, supporting the idea of potentially delaying the progression of DN by neutralizing hyperglycemia's toxic effects (Perkins et al. 2003). Another example of the presence of endogenous protective factors has been exhibited in the finding that the transcription factor nuclear factor (erythroid-derived 2)-like 2 (Nrf2) can activate over 100 genes for both antitoxin and antioxidant enzymes (Tebay et al. 2015). The activation of Nrf2 has been shown to be important as the body's defense against environmental toxins and oxidants (Zhang et al. 2015). A great deal of work now is in progress to determine whether activation of Nrf2 could be a therapeutic target for the treatment of DN and DR (de Zeeuw et al. 2013a). The most important and conclusive evidence that endogenous factors exist to neutralize the toxic effect of hyperglycemia and other metabolic factors induced by diabetes to prevent or delay the progression of DR/DN have come from the Joslin Medalist Study (Keenan et al. 2007). The Joslin Medalist Program is a study which contains a cohort of over 1000 individuals with T1D duration for at least 50 years. The Joslin Medalist Study reported that approximately 35% of the Medalists do not experience significant DR or DN (Keenan et al. 2007). Analysis of those Medalists with and without significant DR or DN did not correlate to their history of glycemic control as measured by over 20 years of HbA1c. Detailed analysis of over 100 Medalists and their rate of progression of DR in this subset of close to 150 Medalists exhibited a bimodal distribution. Over 50% of the Medalists experienced PDR after the onset of the disease of more than 17 years. Though more than 30% of these individuals will develop at most one or two microaneurysms, there will be no progression to severe renal or retinal lesions. Furthermore, history of HbA1c for those with and without DR is also not different. These results clearly demonstrated that at the clinical level endogenous protective factors exist to neutralize the toxic effects of hyperglycemia and other dysmetabolites induced by diabetes (Sun et al. 2011).

In the following, we will provide a detailed description on the potential molecular mechanisms which can be induced by hyperglycemia to cause capillary and microvascular pathologies. This will be followed by a discussion on the mechanisms of

protective factors which are in play to neutralize the toxic effects of hyperglycemia. At the end, we will summarize the proposal that the development of microvascular disease has to be an interplay between increased risk of glucose toxic metabolites and the loss of protective mechanisms.

**Molecular mechanisms of injury.** Multiple abnormalities in cell signaling, gene expression, and regulation of cell biology and physiology have been described in diabetes, and it is likely that many of these abnormalities operate concurrently to cause the various diabetic microvascular complications. These mechanisms may be active preferentially in some, though probably not all, vascular tissues or organs, but generally they are relevant for development of complications in several organs (Fig. 1). The description of the molecular mechanisms will be briefly reviewed since many of them have been studied extensively with extremely long lists of publications. In addition, the summary of these molecular mechanisms will focus mainly on microvascular pathologies (Fig. 2).

---

## Role of the Polyol Pathway

Extracellular hyperglycemia can lead to elevation of intracellular free glucose mostly through the transport of GLUT-1, which is a facilitated transporter (Kaiser et al. 1993). Elevated intracellular free glucose will cause increased flux through main glucose metabolic pathways such as glycolysis and glucose-6 (G6) phosphate pathways, but it can also significantly increase glucose metabolism through those pathways that are not normally activated due to their high  $K_m$  for glucose. This is clearly demonstrated by the increased flux of glucose through the polyol or sorbitol pathway. Aldose reductase (AR), the first enzyme of the polyol pathway, has  $K_m$  between 5 and 10 mM of glucose, which is activated mostly in the hyperglycemic state (Srivastava et al. 1985). The product of AR is sorbitol which is further metabolized by sorbitol dehydrogenase to fructose which is returned back to the glycolytic metabolism (Jeffery and Jornvall 1983). The hyperactivity of this pathway has been postulated to cause diabetic complications both in micro- and macrovascular tissues (Burg and Kador 1988; Ramasamy and Goldberg 2010). It is believed that the hyperflux of glucose to the polyol pathway could potentially cause complications through two ways. First, it is believed that this pathway can consume nicotinamide adenine dinucleotide phosphate (NADPH) in the AR reaction and increase NADPH and reduce NAD in the processing of the sorbitol via the sorbitol dehydrogenase actions resulting in oxidative stress. In addition, it is also believed that the increased activation of AR could elevate sorbitol levels which could provide a hyperosmolar effect to cause cellular dysfunction. Activation of the polyol pathway may result not only from increased availability of free intracellular glucose but also from inactivation of glyceraldehyde 3-phosphate dehydrogenase (GAPDH). This can occur by the addition of adenosine diphosphate (ADP)-ribose moieties to GAPDH by the enzyme poly(ADP-ribose) polymerase (PARP) after its activation by reactive oxygen (Du et al. 2003). Therefore, loss of GAPDH leads to increased levels of

glyceraldehyde 3-phosphate (GA3P), which in turn causes increased production of methylglyoxal, an advanced glycosylated end product (AGE) precursor, or de novo synthesis of diacylglycerol (DAG), a protein kinase C (PKC) activator (Brownlee 2001). However, it should also be noted that the changes in sorbitol levels are in the nanomolar which is unlikely to change cellular or plasma osmolarities significantly. The only site where there is a significant increase in sorbitol levels that could potentially cause pathological changes is the lens, where increase in sorbitol could potentially accelerate cataract formation that is observed in diabetic patients (Lightman 1993). In addition, the rationale for proposing that elevation of sorbitol production can cause complications is the correlation between elevated plasma and tissue sorbitol levels to increased risks of various vascular complications (Gabbay 1973). However, it is also possible that the increased flux through the AR pathway may even be a protective mechanism in order to decrease intracellular free glucose. Therefore, an increased flux through the sorbitol pathway with a combined increase of all of the enzymes in the sorbitol pathway could decrease hyperflux via glycolysis and will be reflected as lower sorbitol levels in those individuals who are protected from complications.

At the mechanistic level, it is suggested that hyperactive polyol pathway may adversely affect cellular homeostasis by depleting cytosolic NADPH, which is necessary to maintain the primary intracellular antioxidant, and glutathione in its reduced state. The deletion of aldose reductase [ $AR^{-/-}$ ] reduced neovascularization and capillary permeability. Levels of VEGF, p-Erk, p-Akt, and p-I $\kappa$ B were reduced in  $AR^{-/-}$  retina (Fu et al. 2012). In mice which were induced to have retinal ischemia by transient middle cerebral artery occlusion,  $AR^{-/-}$  db/db mice had significantly lower retinal swelling than the db/db mice (Yeung et al. 2010). Similarly, AR deficiency in the renal glomeruli protects from the diabetes-induced extracellular matrix accumulation and collagen IV overproduction. Furthermore, AR deficiency completely or partially prevented diabetes-induced activation of renal cortical PKC, transforming growth factor (TGF) $\beta$ 1, and glomerular hypertrophy. Loss of AR resulted in a reduction of urinary albumin excretion in the diabetic  $AR^{-/-}$  mice (Liu et al. 2011).  $AR^{-/-}$  mice were protected from the reduction of motor and sensory nerve conduction velocities observed in diabetic  $AR^{+/+}$  mice. Sorbitol levels in the sciatic nerves of diabetic  $AR^{+/+}$  mice were increased significantly, whereas sorbitol levels in the diabetic  $AR^{-/-}$  mice were significantly lower than those in diabetic  $AR^{+/+}$  mice. Polymorphisms promoter gene region of AR have been associated with susceptibility to neuropathy, retinopathy, or nephropathy. These associations have been replicated in patients with either T1D or T2D as well as across several ethnic groups (Demaine 2003).

Animal studies using AR inhibitors (ARI) showed promise with regard to an effect on diabetic retinopathy or nephropathy, but clinical trials have not confirmed such effects in patients with diabetes. Reports of ARI used in rodents have shown to be effective for preventing capillary abnormalities, especially cataract formation, but not effective in retinopathy in diabetic dogs (Kador et al. 2006; Neuenschwander et al. 1997). One possible explanation for the discrepancy is the high levels of AR expression in rats, especially in the lens.

Clinical trials since the 1980s have generally not confirmed such effects in patients with diabetes except in Japan, where ARI were approved as treatment for diabetic neuropathy. One of these clinical studies, the Aldose Reductase Inhibitor–Diabetes Complications Trial (ARIDCT) was conducted in patients with mild diabetic neuropathy. Among those patients who received ARI, epalrestat treatment showed a reduction in the development of diabetic retinopathy and nephropathy, which may have resulted from the suppressive effect of epalrestat on oxidative and inflammatory stress through inhibition of the polyol pathway. Recently, the efficacy of epalrestat in diabetic retinopathy and nephropathy was examined by re-analysis of the ARIDCT results, with consideration of the influence of patient background factors and severity of DN. The results suggested that epalrestat may have delayed the progression of diabetic retinopathy and nephropathy. Some interesting evidence has been reported that ARI may alter glucose metabolism in the myocardium (Trueblood and Ramasamy 1998).

---

## The Role of the Glycation Modification of Proteins in Diabetic Microvascular Complications

Modification of extracellular and intracellular proteins by sugars can result in the formation of AGE, such as pentosidine, carboxymethyllysine (CML), methylglyoxal, and pyraline (Reddy et al. 2002). Increased concentrations of AGE in plasma and tissues are directly correlated with the level of hyperglycemia (Fleming et al. 2011). AGE formation can occur via a non-enzymatic reaction between glucose and protein through the Amadori product (1-amino-1-deoxyfructose adducts to lysine). However, faster reactions take place between proteins and intracellularly formed dicarbonyls including 3-deoxyglucosone, glyoxal, and methylglyoxal, which result in the cross-linking of proteins. Due to their long turnover rate, structural extracellular proteins such as collagen are prone to accumulate more AGE modification. AGEs have been demonstrated in numerous tissues such as the retina, glomeruli, skin, neurons, and probably all tissues in diabetic states and aging. AGE modification of extracellular matrix proteins and signaling molecules may alter their function. In addition, AGE-modified extracellular proteins may act by binding to receptors, the most well-characterized being receptor for AGE (RAGE) (Chen et al. 2012). RAGE is expressed by most cells including endothelial cells, mononuclear phagocytes, smooth muscle cells, pericytes, mesangial cells, podocytes, and neurons, indicating a potential role in the regulation of their properties in homeostasis and/or their dysfunction in the development of diabetic complications (Schmidt et al. 1994). RAGE is a multi-ligand receptor structurally belonging to the immunoglobulin superfamily. RAGE receptor is composed of extracellular binding domain and a short cellular cytosolic domain (43 amino acids) which binds to diaphanous-1 (DIAPH1) (Hudson et al. 2008). Binding to RAGE on the endothelial cell surface has been reported to stimulate NOX and increase ROS, p21 RAS, and mitogen-activated protein kinase (MAPK). The AGE-RAGE interaction may stimulate signaling via p38 MAPK and Rac/Cdc, although its exact mechanism is unclear

since RAGE is not an enzyme. A key target of RAGE signaling is nuclear factor  $\kappa$ B (NF- $\kappa$ B), which is translocated to the nucleus where it increases transcription of a number of different proteins, including ET-1, ICAM-1, E-selectin, and tissue factor (Goldin et al. 2006). The ability of RAGE signaling to cause diabetic complications has been reported in transgenic mice overexpressing both inducible nitric oxide synthase (NOS) (iNOS) and RAGE in all cells. These double transgenic mice developed accelerated glomerular lesions (Yamamoto et al. 2001), which could be prevented by an AGE inhibitor. A soluble receptor for AGE prevents development of increased vascular permeability and atherosclerosis (Park et al. 1998). Furthermore, diabetic rats treated with RAGE fusion protein inhibitor displayed beneficial effects on early diabetic retinopathy and signs of neuropathy (Li et al. 2011). RAGE has been implicated to have a role in many diseases where inflammation is important, even in the absence of diabetes, such as cancer, atherosclerosis, insulin resistance, and Alzheimer's disease (Ramasamy et al. 2009). Thus, it is likely that AGE and RAGE have significant effects in the inflammatory cascade but not unique to diabetes. Thus, the pathophysiological effects of AGE and RAGE are to accelerate the main pathway of inflammation. The enhancement nature of AGE/RAGE for inflammation is further supported by the findings that RAGE knockout (KO) mice do not manifest significant pathologies (Sakaguchi et al. 2003). Clinical trials are ongoing for small molecule antagonists of RAGE (Yan et al. 2010). Other approaches have been used to inhibit tissue accumulation of AGE in diabetes, including inhibitors of AGE formation such as aminoguanidine, ALT 946, and pyridoxamine or putative cross-link breakers such as ALT 711 (Jandeleit-Dahm et al. 2005). Interestingly, not all AGE or their actions affect vascular cells adversely. Several recent studies have reported inverse correlations of CML and fructoselysine with vascular complications (Sun et al. 2011). Further studies have suggested that food with high AGE content such as those cooked on grills could potentially elevate circulating AGEs (Goldberg et al. 2004). A recent clinical report suggested that low AGE diet improved insulin resistance compared to high AGE diets, again suggesting that AGE contributed in the general elevations of inflammatory cytokines systemically (Mark et al. 2014).

---

## **Oxidative Stress in the Pathogenesis of Diabetic Microvascular Complications**

Production of superoxide and other ROS in vascular cells may play an important role in the pathogenesis of vascular diseases in diabetes. A major source of superoxide in vascular is thought to be from the family of NADPH oxidases (NOX) that favors NADH as a substrate (Lassegue et al. 2012). Elevation of oxidants and signal enzymes such as PKC can induce NOX 1, 2, and 4 with NOX 1, 2, 4, and 5 in endothelial and contractile cells (Lassegue et al. 2012). Expression and activity of NOX are increased in the vascular tissue of rodents with T1D (Hink et al. 2001) and T2D (Kim et al. 2002). NOX may be activated by an increase in the NADH/NAD<sup>+</sup> ratio, which in diabetes may be caused by an increased flux through the polyol pathway (see above) or activation of poly(ADP-ribose) polymerase (PARP) (Garcia

Soriano et al. 2001). NOX activity may also be increased by hyperglycemia through PKC activation (Inoguchi et al. 2000). In animal models, Baicalein, a NOX inhibitor, reduced vascular hyperpermeability and improved retinal endothelial cell barrier dysfunction (Othman et al. 2013). However, the role of NOX isoforms in the pathogenesis of diabetic kidney disease is unclear and was evaluated by You et al. using the NOX2 knockout mice with insulin-deficient diabetes (You et al. 2013). They reported that lack of NOX2 does not protect against diabetic kidney disease despite a reduction in macrophage infiltration (You et al. 2013). Apocynin, a NOX inhibitor, treatment corrected the reduced sciatic nerve motor conduction velocity, sensory saphenous nerve deficit blood flow, and vascular conductance that are known to be reduced in diabetes (Cotter and Cameron 2003).

Mitochondria are another important source of reactive ROS. The citric acid cycle provides NADH and flavin adenine dinucleotide (FADH<sub>2</sub>) that can act as electron donors for the electron transport chain, creating a proton gradient over the inner mitochondrial membrane (Brownlee 2001). When intracellular glucose concentration increases, and thereby yields excessive reducing equivalents for this process, the proton gradient increases and inhibits the transfer of electrons from reduced coenzyme Q (ubiquinone) to complex III of the electron transport chain (Brownlee 2001). Instead, electrons are transferred to molecular oxygen, causing production of superoxide.

Nitric oxide (NO) can neutralize ROS, but paradoxically, eNOS can become a source of ROS if an already pro-oxidant redox state favors oxidation of the eNOS cofactor tetrahydrobiopterin (BH<sub>4</sub>). This leads to uncoupling of electron transport in eNOS and release of superoxide (Laursen et al. 2001). By promoting DNA strand breaks, oxidative stress can activate PARP, which in turn can activate NF- $\kappa$ B and cause endothelial dysfunction (Garcia Soriano et al. 2001). Oxidative stress can also inhibit the proteasomal degradation of homeo-domain-interacting protein kinase 2 (HIPK2), which promotes kidney fibrosis through activation of p53, TGF- $\beta$ , and WNT (Jin et al. 2012).

In vitro studies suggest oxidative stress may contribute to diabetic nephropathy and retinopathy. Cultured rat mesangial cells (MC) incubated with high glucose in the presence of tyrosine kinase (c-Src) inhibitor, which is sensitive to oxidative stress, showed a reduction in collagen type IV accumulation (Taniguchi et al. 2013). Similar results were obtained in vivo in streptozotocin (STZ)-induced diabetic mice, where treatment with Src inhibitor reduced albuminuria, glomerular collagen accumulation, and podocyte loss (Taniguchi et al. 2013). Podocyte injury, a major contributor to the pathogenesis of diabetic glomerulopathy, may in part be the excessive generation of ROS. Overproduction of superoxide by NOX4 may also have an important role in podocyte injury. Khasim et al. reported that treatment with the plant extract Silymarin, which is known to have antioxidant properties, reduced the high glucose-induced apoptosis in cultures of mouse podocytes. In T2D patients with macroalbuminuria, Silymarin treatment reduces urinary excretion of albumin and has been suggested as a treatment for preventing the progression of diabetic nephropathy (Fallahzadeh et al. 2012).

Increased ROS is reported to cause major retinal metabolic abnormalities associated with the development of diabetic retinopathy. NF-E2-related factor 2 (Nrf2), a redox-sensitive factor, provides cellular defenses against the cytotoxic ROS. In stress conditions, Nrf2 dissociates from its cytosolic inhibitor, Kelch-like-ECH-associated



protein 1 (Keap1), and moves to the nucleus to regulate the transcription of several antioxidant genes including the catalytic subunit of glutamyl cysteine ligase (GCLC), a rate-limiting reduced glutathione (GSH) biosynthesis enzyme (see section “[Antioxidant Enzymes](#)”). Diabetes increased retinal Nrf2 and its binding with Keap1 but decreased DNA-binding activity of Nrf2 and also its binding at the promoter region of GCLC. Similar impairments in Nrf2-Keap1-GCLC were observed in the endothelial cells exposed to high glucose and in the retina from donors with diabetic retinopathy (Zhong et al. 2013).

So far, large clinical trials using antioxidants, vitamins E or C, for prevention or treatment of diabetic retinopathy and other vascular complications have not shown conclusive evidence for efficacy when definitive endpoints were measured in humans (Kowluru and Zhong 2011). The Heart Outcomes Prevention Evaluation (HOPE) study reported that daily administration of vitamin E for an average of 4.5 years to middle-aged and elderly people with diabetes and cardiovascular disease (CVD) and/or additional coronary risk factor(s) had no effect on nephropathy (Lonn et al. 2002). Likewise,  $\alpha$ -lipoic acid treatment failed to show a clinically significant improvement on macular edema (Haritoglou et al. 2011). However, a recent epidemiological study in cohort of T2D patients reported that the risk for diabetic retinopathy declined with increased intake of vitamin C (Tanaka et al. 2013).

Diabetic peripheral neuropathy (DPN) is associated with decrements in motor and sensory neuron myelination and nerve conduction; however, the mechanisms of reduced myelination in diabetes are poorly understood. Chronic elevation of oxidative stress may be one of the potential determinants for demyelination as lipids and proteins are important structural constituents of myelin and highly susceptible to oxidation. Using the leptin receptor-deficient mouse (db/db) model of DPN and the superoxide dismutase 1 knockout [Sod1(-/-)] mouse model of in vivo oxidative stress, Hamilton reported that oxidation-mediated protein misfolding and aggregation of key myelin proteins may be linked to demyelination and reduced nerve conduction in peripheral neuropathies (Hamilton et al. 2013).

Some human studies have reported a high total oxidative status (TOS) and oxidative stress index (OSI) levels together with low levels of serum total antioxidant status (TAS) in serum from diabetic patients with neuropathy (Uzar et al. 2012). In a double-blind placebo-controlled trial in subjects with T2D and DPN, treatment with vitamin E improved electrophysiological parameters of nerve function, including motor nerve conduction velocity (NCV) and tibial motor nerve distal latency (Tutuncu et al. 1998). Furthermore, a meta-analysis reported that treatment with the antioxidant  $\alpha$ -lipoic acid significantly improved both nerve conduction velocity and positive neuropathic symptoms (Han et al. 2012).

---

## Activation of Protein Kinase C in Vascular Tissues

PKC is a family of serine/threonine-related protein kinases of multiple isoforms that play key roles in many cellular functions and affects many signal transduction pathways (Newton 2003). The conventional PKC (cPKC) isoforms (PKC $\alpha$ , - $\beta$ 1, - $\beta$

2, and  $\gamma$ ) are activated by phosphatidylserine, calcium, and DAG or phorbol esters such as phorbol 12-myristate 13-acetate (PMA), whereas novel PKC (nPKC) isoforms (PKC $\delta$ ,  $\epsilon$ ,  $\phi$ , and  $\eta$ ) are activated by phosphatidylserine and DAG, but not calcium. The atypical PKC (aPKC) isoforms (PKC $\zeta$  and  $\iota/\lambda$ ) are not activated by calcium or DAG. In this review, we highlighted the mechanism by which hyperglycemia modulates PKC activation. PKC can also be activated by oxidants such as H<sub>2</sub>O<sub>2</sub> in a manner unrelated to lipid second messengers (Konishi et al. 1997) and by mitochondrial superoxide induced by elevated glucose levels (Nishikawa et al. 2000). Many abnormal vascular and cellular processes, including endothelial dysfunction, vascular permeability, angiogenesis, cell growth, and apoptosis, changes in vessel dilation, basement membrane thickening, and extracellular matrix (ECM) expansion; enzymatic activity alterations, such as in mitogen-activated protein kinase (MAPK), cytosolic phospholipase A2, Na<sup>+</sup>/K<sup>+</sup>-ATPase; and alterations in several transcription factors are attributed to the activation of several PKC isoforms. PKC activity is increased by diabetes in the renal glomeruli, retina, almost all of the vessels and the myocardium, as well as skeletal muscle wounds and liver (Geraldes and King 2010). Among the isoforms of PKC, the  $\alpha$ ,  $\beta$ , and  $\delta$  isoforms have been most consistently implicated in diabetic vascular complications.

---

## Evidence for the Activation of Diacylglycerol (DAG)-PKC Pathway in Diabetes

DAG levels are elevated chronically in the hyperglycemic or diabetic environment due to increased levels of glycolytic intermediate dihydroxyacetone phosphate. This intermediate is reduced to glycerol-3-phosphate, which subsequently increased de novo synthesis of DAG (Xia et al. 1994). In diabetes, total DAG levels were found to be elevated in vascular tissues, such as the retina (Shiba et al. 1993), and renal glomeruli. However, there is no consistent change in DAG levels in the central nervous system and peripheral nerves (Ido et al. 1994). Cell culture studies have shown that DAG levels increase in a time-dependent manner as glucose levels elevate from 5.5 to 22 mmol/L in aortic and capillary endothelial cells (Inoguchi et al. 1992), retinal pericytes (Geraldes et al. 2009), smooth muscle cells (Xia et al. 1994), kidney proximal tubular cells (Wu et al. 2000), and renal mesangial cells (Ayo et al. 1991). Alternatively, increased DAG synthesis can occur from the glycolytic intermediate dihydroxyacetone phosphate, which accumulates when the glycolytic enzyme glyceraldehyde 3-phosphate dehydrogenase (GAPDH) is inhibited by poly-ADP-ribosylation of high glucose concentrations (Du et al. 2003). Elevated cytosolic glucose levels promote the accumulation of glyceraldehyde 3-phosphate (GA3P), which can increase DAG and activate PKC (Geraldes and King 2010). Large doses of thiamine and thiamine monophosphate derivative, benfotiamine, may decrease the formation of DAG and mitigate PKC activation in an experimental model of diabetes (Babaei-Jadidi et al. 2003).

## PKC Activation in the Development of Diabetic Nephropathy

Experiments in diabetic mice and rats support a role for PKC in the pathogenesis of diabetic nephropathy (DN): PKC $\alpha$ ,  $\beta$ , and  $\delta$  isoforms are activated in renal glomeruli isolated from rats (Babazono et al. 1998) and mice with streptozotocin-induced diabetes, and 50% of the increase in PKC activity in renal glomeruli is prevented in PKC $\beta$  knockout mice (PKC $\beta$ KO) (Ohshiro et al. 2006). PKC activity is also increased in mesangial cells and podocytes cultured in high-glucose media (Ayo et al. 1991). Activation of PKC $\alpha$  can upregulate VEGF expression through NADPH oxidase (Thallas-Bonke et al. 2008). PKC $\alpha$  knockout mice are protected against loss of basement membrane proteoglycans induced by VEGF (Menne et al. 2004). In wild-type mice, diabetes increases activity of NADPH oxidase and induces expression of endothelin-1 (ET-1), VEGF, transforming growth factor  $\beta$  (TGF- $\beta$ ), connective tissue growth factor (CTGF), and collagen types IV and VI. These changes are partly prevented in PKC $\beta$  knockout mice (Ohshiro et al. 2006). Mesangial expansion and albuminuria in mice with streptozotocin-induced diabetes are reduced in both PKC $\beta$  (Ohshiro et al. 2006) and PKC $\delta$  (Mima et al. 2012) KO mice compared to wild type.

General PKC isoform inhibitors can interact with other ATP-binding kinases and therefore display significant toxic side effects *in vivo*. The PKC- $\beta$  inhibitor, ruboxistaurin (RBX), is a bisindolylmaleimide class agent and selectively inhibits PKC $\beta$ 1 and PKC $\beta$ 2 (Jirousek et al. 1996). Rottlerin (mallotoxin) has higher affinity for PKC $\delta$  but also inhibits other isoforms of PKC (Parmer et al. 1997) and other non-PKC kinases, such as MAPK, PKA, and glycogen synthase kinase-3 (Soltoff 2007). The oral administration of RBX was reported to reverse glomerular hyperfiltration and reduce urinary albumin excretion in rodent models of diabetes without a change in DAG content (Tuttle and Anderson 2003).

Improvements were also noted in glomerular TGF- $\beta$ 1 expression, mesangial expansion, glomerulosclerosis, tubule-interstitial fibrosis, and renal function.

Remarkably, PKC $\epsilon$  may have effects on DN opposite of PKC $\alpha$ , PKC $\beta$ , and PKC $\delta$ . One study showed that knockout of PKC $\epsilon$  upregulated renal TGF $\beta$ 1 and its downstream signaling and increased expression of fibronectin and collagen type IV, which caused glomerular and tubulointerstitial fibrosis and development of albuminuria (Meier et al. 2007). These changes were further aggravated by diabetes (Meier et al. 2007). Therefore, PKC $\epsilon$  may act as a protective factor by reducing kidney damage.

Supporting the relevance of these findings for human disease, polymorphisms of the PKC $\beta$  gene accelerated kidney disease in Japanese subjects with T2D without overt proteinuria (Araki et al. 2006), and polymorphisms in the PKC $\beta$ 1 gene have been associated with end-stage renal disease in Chinese patients with T2D (Ma et al. 2010).

---

## Clinical Studies Using RBX for Treatment of DN

RBX has been described to stabilize the progression of nephropathy in patients with T2D and early diabetic nephropathy. One year of RBX treatment reduced albuminuria and stabilized the estimated glomerular filtration rate (e-GFR). However, renal

outcomes that were evaluated in a secondary analysis of three DN trials (Tuttle et al. 2005) showed no differences in kidney outcomes with RBX treatment.

---

## PKC Activation in the Development of Diabetic Retinopathy

Hyperglycemia activates several PKC isoforms in retinal tissues, including PKC $\alpha$ , - $\beta$ , - $\delta$ , and - $\epsilon$  (Geraldes and King 2010). PKC activation causes retinal vascular dysfunction by altering activities of ET-1, VEGF, and nitric oxide (NO) levels in endothelial cells and platelet-derived growth factor (PDGF), reactive oxygen species (ROS), and nuclear factor  $\kappa$ B in pericytes (Idris et al. 2001). RBX administration to diabetic rats normalized retinal blood flow (RBF) (Ishii et al. 1996). Furthermore, local intravitreal injection of RBX reduced retinal PKC activation and restored RBF (Bursell et al. 1997). Alterations in NO production and endothelial nitric oxide synthase (eNOS) expression directly influenced vascular hemodynamics, which may affect RBF. In vessels isolated from diabetic animals, acetylcholine-induced vessel relaxation was found to be delayed (Matsumoto et al. 2008), and the PKC agonist, phorbol 12-myristate 13-acetate (PMA), provoked vascular relaxation impairment in normal arteries (Kamata et al. 1995).

The mechanism for reduced RBF mediated by PKC $\beta$  involves ET-1, which is upregulated in the retina of diabetic rats (Yokota et al. 2003). This induction of retinal ET-1 can be blocked by treatment with RBX (Yokota et al. 2003). Diabetic macular edema is mediated in part by VEGF through signaling involving PKC $\beta$  (Aiello and Cavallerano 1997) to increase phosphorylation of occludin, a component of tight junctions, leading to increased vascular permeability (Murakami et al. 2012) and others like kallikrein activation (Feener et al. 2013). Hyperglycemia may also increase endothelial cell permeability via the activation of PKC $\alpha$  isoform (Hempel et al. 1997).

The impact of hyperglycemia on vascular cell survival has been extensively studied. However, PKC's actions on vascular cell proliferation and death have been clarified only recently. Both PKC $\beta$  and PKC $\delta$  isoforms are translocated to the membrane fraction in total retinal lysates of diabetic mice, but the consequences of PKC $\beta$ ,  $\delta$ , and  $\epsilon$  isoform activation are very different. PKC $\delta$  was found to induce cellular apoptosis (Geraldes et al. 2009) whereas PKC $\beta$  enhanced cellular growth (Suzuma et al. 2002). Accordingly, the elevation of membranous PKC $\delta$  levels in diabetes correlated with the appearance of retinal pericyte apoptosis *in vitro* and acellular capillaries *in vivo*. *In vivo* studies showed that induction of retinal PKC $\delta$  in the retinal capillaries of diabetic mice leads to PDGF resistance, which is not observed in PKC $\delta$  knockout mice. We showed that hyperglycemia through PKC $\delta$  action promotes two distinctly important pathways by (a) increasing ROS production and NF- $\kappa$ B activity and (b) decreasing the important survival signaling pathway of PDGF by upregulating the expression of SHP-1. These findings suggest a pivotal role for PKC $\delta$  in regulating pericyte apoptosis and the formation of cellular capillaries (Geraldes et al. 2009).

In animal studies, inhibition of PKC $\beta$  ameliorated the decline of retinal blood flow associated with diabetic retinopathy and prevents diabetes-induced vascular leakage (Ishii et al. 1996). Similarly, the stimulus for neovascularization is suppressed in animals with a reduction of PKC $\beta$  levels (Suzuma et al. 2002; Danis et al. 1998). More recently, Nakamura showed that retinal neovascularization was reduced by subcutaneous RBX treatment. In addition, the RBX anti-angiogenic effects were found to be exerted partly via suppressing the phosphorylation of ERK1/2 and Akt (Nakamura et al. 2010).

*Clinical studies on diabetic retinopathy with ruboxistaurin.* Phase II and phase III clinical trials were conducted in late stages of nonproliferative diabetic retinopathy (NPDR), with the loss of visual acuity as the primary endpoint. Phase II clinical trials, PKC-Diabetic Retinopathy Study (PKC-DRS) and PKC-Diabetic Macular Edema Study (PKC-DMES) (Aiello et al. 2011), failed to reach primary outcomes because of multiple factors (underpowered, three treatment arms of differing dosages, high dropout rate of patients). However, there was a significant reduction in the secondary endpoint of the progression of diabetic macular edema. A much larger clinical trial, PKC-DRS2, was undertaken using a single oral dose with the primary endpoint, again, the loss of visual acuity (Aiello et al. 2006). RBX treatment significantly prevented the reduction of visual acuity in diabetic patients with moderate vision loss and decreases the onset of diabetic macular edema (The PKC-DRS Study Group 2005). These clinical results suggest that PKC activation, especially of the  $\beta$  isoform, could participate in the development of NPDR. However, because treatment with RBX preserves visual acuity by decreasing capillary permeability or targeting the neural retina, but does not significantly delay the progression of vascular DR, suggests that inhibition of the PKC $\beta$  isoform alone is not adequate to stop the early metabolic changes that are likely driving the progression of proliferative diabetic retinopathy (PDR). Recently, the effect of RBX on vision loss was assessed through a prospectively defined combined analysis of two phase III trials (MBDL and MBCU) and showed a magnitude effect of RBX on vision loss similar to that seen in the DMES and DRS studies. However, event rates were low and statistical significance was not achieved (Sheetz et al. 2013).

---

## **Role of PKC in the Development of Diabetic Peripheral Neuropathy (DPN)**

Neuropathy is one of the most distressing complications of diabetes and involves the entire peripheral nervous system due to hyperglycemic states (Dyck et al. 1993). Healthy nerves receive a rich supply of blood from surrounding neural microvasculature known as the vasa nervorum (Cameron et al. 2001). This microvascular network is damaged by hyperglycemia (Sytze Van Dam et al. 2013). Hyperglycemia eventually leads to impaired vasodilation and vascular injury, such as capillary basement membrane thickening and endothelial hyperplasia, resulting in diminished oxygen tension and hypoxia leading to damage to neuronal cells (Cameron et al. 2001). Additionally, hyperglycemia reduces Na<sup>+</sup>/K<sup>+</sup>-ATPase activation, an enzyme

essential in maintaining normal nerve membrane resting potential, as well as providing neurotrophic support (Stevens et al. 1994).

Changes in PKC activation can contribute to diabetic neuropathy by neurovascular mechanisms such as blood flow and conduction velocity. Levels of DAG have not been shown to be increased in nerve cells, and data from studies of PKC activity in nerve cells have been conflicting, which have reported its activity as increased, decreased, or unchanged (Eichberg 2002). Hyperglycemia in neurons has been shown to decrease phosphatidylinositol, thereby decreasing DAG levels and actually decreasing PKC activity. This diminished activity reduces phosphorylation of  $\text{Na}^+/\text{K}^+$ -ATPase, leading to a decrease in nerve conduction and regeneration. A previous report demonstrated a reduction of PKC activity by direct measurement of sciatic nerve tissues in STZ diabetic rats (Kim et al. 1991). These results contrast with more recent studies showing that treatment with nonselective PKC isoform inhibitor as well as selective PKC $\beta$  inhibitor improved neural function in diabetic animals (Yamagishi et al. 2003). Some studies have reported that treatment with the PKC $\beta$  inhibitor resulted in improved nerve conduction as well as improved neuronal blood flow (Nakamura et al. 1999). Indeed, Cameron et al. showed that treatment with RBX at low dose improves motor nerve conduction velocity, normalizes nerve blood flow, and restores  $\text{Na}^+/\text{K}^+$ -ATPase activity in diabetic rats (Cameron and Cotter 2002).

*In humans:* Vinik et al. conducted an analysis of a 1-year trial that used a standardized clinical neurological examination to assess the effects of RBX on DPN (Vinik et al. 2005). Changes in vibration detection threshold (VDT) and Neuropathy Total Symptoms Score-6 (NTSS-6), total score did not differ among treatment groups at endpoint. However, RBX treatment appeared to be of benefit for the subgroup of patients with less severe symptomatic DPN by relieving sensory symptoms and improving nerve fiber function, as indicated by reductions in VDT and NTSS-6 total score (Vinik et al. 2005). PKC $\beta$  inhibition enhanced skin microvascular blood flow at the distal calf, reduced NTSS-6, and improved measures of Norfolk QOL-DN (Casellini et al. 2007). More recently, Boyd et al. reported that RBX produced significant improvement in large fiber measures QOL and NTSS-6 in diabetic patents (Boyd et al. 2011).

---

## PKC $\delta$ Activation in Fibroblasts and Wound Healing

Abnormalities of wound healing, as exemplified by chronic foot ulcers, are major complications of diabetes. Poor wound healing in diabetic patients are due to a combination of multiple causes such as neuropathy, delay in recruitment of immune responses, and poor angiogenesis and fibroblasts functions. Recent studies have shown that abnormal functioning fibroblasts from diabetic patients produced less VEGF in response to wounds, hypoxia, and growth

factors such as insulin, resulting in less angiogenesis and delay in wound closure. These abnormal functions of the fibroblasts from diabetic patients were associated with PKC $\delta$  activation. When PKC $\delta$  isoforms were inhibited with small molecules or overexpression of PKC $\delta$  dominant-negative using adenoviral vectors, the functions of fibroblasts derived from diabetic patients were normalized with respect to VEGF production, angiogenesis, and wound closure, suggesting that PKC $\delta$  isoform activation could be causing fibroblast dysfunction and poor angiogenesis expression in delay in wound closure in diabetic patients (Khamaisi et al. 2016).

In summary, there is substantial evidence that PKC $\beta$  and  $\delta$  inhibition could be mediating some of the micropathologies in early changes of microvascular complications. However, it is also clear that to achieve clinical significance on the prevention or treatment of these microvascular complications, inhibition of multiple PKC isoforms, including  $\alpha$ ,  $\beta$ , and  $\delta$ , may be needed.

---

## **Renin-Angiotensin System (RAS) in the Pathogenesis of Diabetic Microvascular Complications**

A large number of clinical trials have clearly shown that treatment with angiotensin-converting enzyme (ACE) inhibitors, angiotensin type 1 (AT1) receptor blockers, or their combination may delay the onset of renal disease or progression to renal failure (Burnier and Zanchi 2006). However, analysis of renal biopsies from T1D patients treated with these drugs did not exhibit improvement in glomerular pathology, indicating that inhibition of the RAS may only delay the progression of functional impairment in diabetic nephropathy (Mauer et al. 2009). Angiotensin I and II (AngI, AngII) are produced locally in the kidney, and part of the renoprotective effect of ACE inhibition is a decrease of glomerular capillary pressure beyond lowering systemic blood pressure. AngII actions may also lead to kidney damage through induction of local factors, including extracellular matrix protein synthesis via TGF- $\beta$  and inflammatory cytokines (Kagami et al. 1994). The mechanisms of angiotensin actions are mediated by AngII receptors, leading to the activation of RAF kinase/MAP kinase and multiple inflammatory cytokines such as TNF- $\alpha$ , IL-6, and others (Zou et al. 1998). Furthermore, RAS blockade may improve or delay the development of DR and macular edema in diabetic patients (Wang et al. 2012). Similarly, RAS blockade reduces DR progression in normotensive, normal albuminuric T1D patients (Harindhanavudhi et al. 2011), suggesting their beneficial effects may be more than just the reduction of blood pressure. In animal models of diabetes, renin inhibitor, Aliskiren, provided similar or greater protection than ACE inhibition alone to decrease NPDR and proliferative neoangiogenesis. In transgenic (mRen-2)<sup>27</sup> rats, which overexpress mouse renin in extrarenal tissues, Aliskiren treatment reduced retinal acellular capillaries and leukostasis and normalized retinal vascular endothelial growth factor expression (Wilkinson-Berka et al. 2011).

## **Role of Endoplasmic Reticulum (ER) Stress in Diabetic Microvascular Complications**

ER plays an important role in  $\text{Ca}^{+2}$  and redox homeostasis, lipid biosynthesis, and protein folding. Increases in protein synthesis, protein misfolding, or perturbations in  $\text{Ca}^{+2}$  and redox balance can disturb ER function and cause ER stress. In response, a coordinated program referred to as the unfolded protein response (UPR) is initiated to reduce translation and increase protein folding capacity in an attempt to restore ER homeostasis. Under conditions of chronic, unresolved ER stress, the UPR can also initiate signaling events that promote apoptosis. UPR genes are upregulated in kidney tissue from patients with diabetes, and ER stress may be a mediator of diabetic nephropathy. In the retina of diabetic rats, ER stress is involved in upregulation of inflammatory genes and VEGF and increased vascular permeability (Jing et al. 2012). These and other findings have prompted development of therapeutics which can ameliorate ER stress in patients, including synthetic chaperones to promote protein folding and inhibitors of CHOP and other molecules enabling the UPR (Jing et al. 2012).

A small number of studies have also implicated ER dysfunction in the pathogenesis of diabetic neuropathy. In cultured Schwann cells (SC), knockdown of ORP150 promoted high glucose-induced SC apoptosis, whereas knockdown of CHOP protected SC from apoptosis.

In rat models of high-fat STZ-diabetes, knockdown of anti-apoptotic protein ORP150 induced DPN in early diabetes and exacerbated DPN after prolonged diabetes, whereas knockdown of the pro-apoptotic protein CHOP ameliorated DPN in rats with prolonged diabetes (Wu et al. 2013).

---

## **Role of Kallikrein-Bradykinin System in the Development of Diabetic Microvascular Complications**

Plasma kallikrein (PK) is a serine protease with well-characterized effects in innate inflammation and the intrinsic coagulation cascade (Sainz et al. 2007). The majority of PK physiological actions have been attributed to cleavage of its two primary substrates and cofactors, namely, FXII and high-molecular-weight kininogen (HK). Conversion of FXII to FXIIa leads to activation of FXI and the intrinsic coagulation cascade resultant in fibrin production and thrombus stabilization. Cleavage of HK releases the nonapeptide bradykinin, which is the ligand for the G protein-coupled B2 receptor (B2R). Subsequent cleavage of bradykinin by carboxypeptidases generates des-Arg9-bradykinin, which binds and activates the B1 receptor (B1R). Activation of B2R and B1R by bradykinin and des-Arg9-bradykinin, respectively, has been implicated in nearly all the effects of the plasma kallikrein-kinin system (plasma KKS) on inflammation, vascular function, blood pressure regulation, and nociceptive responses (Marceau and Regoli 2004). The plasma KKS has been implicated in a variety of coagulation, vascular, and metabolic abnormalities in



diabetes. However, most of the physiological effects of the KKS have been examined using bradykinin receptor-targeted approaches.

---

## Role of the Kallikrein-Kinin System in Diabetic Retinopathy

Activation of the KKS exerts a number of biological effects that also occur in DR, including increased vascular permeability and edema, changes in vascular diameter and hemodynamics, and a variety of effects on inflammation, angiogenesis, and neuronal functions.

*Retinal vascular permeability:* Intraocular activation of the KKS by injection of C1-INH into the vitreous has been shown to increase RVP, and this response was inhibited by the co-injection of C1-INH, a neutralizing antibody against PK, and a small molecule PK inhibitor, 1-benzyl-1 *H*-pyrazole-4-carboxylic acid 4-carbamimidoyl-benzylamide (ASP-440) (Clermont et al. 2011). Intravitreal injection of PK increased RVP and retinal thickness by a greater extent in diabetic rats, suggesting that diabetes enhances the retinal responses to intraocular KKS activation. Systemic administration of ASP-440 decreased RVP both in diabetic rats and in rats subjected to AngII-induced hypertension (Clermont et al. 2011; Phipps et al. 2009). Intravitreal injection of BK increased RVP in both diabetic and nondiabetic rats, whereas only diabetic rats demonstrated an RVP response to des-Arg 9-bradykinin (DABK) (Phipps et al. 2009; Abdouh et al. 2008). The administration of B1R antagonist reduced RVP in diabetic rats (Abdouh et al. 2008; Lawson et al. 2005). The data in animal models suggest that the activation of the KKS in the circulation and/or locally in the retina and vitreous can increase RVP via both B1R and B2R and that diabetes appears to increase actions mediated via the B1R.

*Retinal blood flow and vasodilation:* KKS regulate retinal vessel diameters and hemodynamics. Intravitreal injection of BK acutely stimulated increases in retinal vessel diameters and blood flow (Sogawa et al. 2010), whereas intravenous infusion increases retinal vessel diameter (Kojima et al. 2009). DABK increased vessel diameters in the retinal vessels from diabetic rats but not in nondiabetic controls (Abdouh et al. 2003). The effects of B1R and B2R on retinal vessel dilation have been mainly attributed to NO and prostaglandin (PG) generation from vascular endothelial cells. Pouliot et al. have shown that B1R blockade reduces the retinal expression of potential inflammatory mediators, including iNOS and COX-2. In vitro BK-induced vasodilation responses were inhibited by *N* G-nitro-L-arginine methyl ester, indomethacin, and the B2R antagonist Hoe140, suggesting that the vasodilation induced by BK is mediated by NO and PG (Abdouh et al. 2003; Jeppesen et al. 2002). BK and DABK stimulate increases in the intracellular concentrations of free calcium by coupling G  $\alpha$  q/11 or G  $\alpha$  i/o through the B2R or B1R, respectively (Busse and Fleming 1996; Kuhr et al. 2010). Ca<sup>2+</sup>-induced stimulation of phospholipase A2 (PLA2) liberated the arachidonic acid from the membrane phospholipids, which can lead to the synthesis of prostacyclin (PGI2) (Kolte et al. 2011). B2R stimulates NOS phosphorylation via Ca<sup>2+</sup>-calmodulin-dependent activation, whereas under inflammatory conditions, B1R stimulation

results in a much higher and prolonged NO production via  $G\alpha_i$  activation of the MAP kinase pathway, leading to the activation of iNOS (Kuhr et al. 2010; Brovkovych et al. 2011). The activation of eNOS and iNOS can independently and additively increase NO production (Kuhr et al. 2010; Yayama and Okamoto 2008). BK also activates the Src kinases and the subsequent vascular endothelial cadherin (VEC) phosphorylation, leading to the quick and reversible opening of endothelial cell junctions and plasma leakage (Orsenigo et al. 2012).

*KKS inhibitors—A novel therapeutic application to diabetic retinopathy:* In both humans and animal models, the genetic deficiency of PPK causes the prolongation of the activated partial thromboplastin time (APTT) without causing an apparent prothrombotic phenotype or bleeding diathesis (Girolami et al. 2010), and this decrease is reversed by the systemic administration of a PK inhibitor. These results suggest that systemic PK activity contributes to APTT shortening in diabetes because increased activities of PK and BK receptors have been linked to vasogenic edema (Plesnila et al. 2001).

Targeting the KKS could occur at multiple levels, including:

- (a) **Inhibiting contact system activation:** Decreasing the contact system activation may provide opportunities to reduce the effects of the KKS in DR. Feener et al. described that carbonic anhydrase (CA)-1 is increased in the vitreous in PDR patients and intravitreal injection of CA-1 into rats increases RVP, and this response is blocked by co-injection with CA inhibitors, a PK-neutralizing antibody, BK receptor antagonists, and a small-molecule PK inhibitor (Feener et al. 2013; Clermont et al. 2011). These findings revealed that increased CA activity in the vitreous leads to KKS activation and suggest that CA-1 inhibitors may reduce DME, in part, via the reduction of the PK activity.
- (b) **Plasma kallikrein inhibitors:** PK inhibitors include endogenous inhibitors, engineered proteins, and small molecules. C1-INH is a primary physiological inhibitor of PK, FXIa, FXIIa, C1r, and C1s proteases. Intravitreal injection of exogenous C1-INH reduced retinal vascular hyperpermeability induced by diabetes and by intravitreal CA-1 in rats (Clermont et al. 2011). Although C1-INH is detected in the vitreous, it is unknown whether intravitreal concentrations of this endogenous serpin protease inhibitor are sufficient to inhibit PK. Exogenously administered C1-INH into the vitreous may provide an opportunity to inhibit the KKS, as well as other proteases in the complement and intrinsic coagulation cascades. Selective PK inhibition could provide increased efficacy and targeting of the inflammatory effects of the plasma KKS while preserving the potential beneficial effects of the tissue kallikrein system.
- (c) **B1 receptor antagonists:** The effects of the KKS are mediated in large part via the generation of BK peptides that activate B1 and B2 receptors, which are expressed in a variety of ocular cell types and tissues. Because both PK- and tissue kallikrein-mediated pathways activate BK receptors, the antagonism of these receptors blocks the effects of both kallikrein systems. Although both B1 and B2 receptors can induce RVP, B1R appears to increase plasma extravasations in DR. The selective peptide B1R antagonist, R-954, reduced vascular

permeability in a variety of tissues from STZ-induced diabetic rats, including the retina (Lawson et al. 2005). When diabetic rats were treated with R-954, NO, kallikrein activity, and capillary permeability were remarkably reduced and the  $\text{Na}^+/\text{K}^+$ -ATPase activity in the retina was increased (Catanzaro et al. 2012). Treatment with FOV-2304, a nonpeptide B1R antagonist, reduced RVP and normalized retinal mRNA expression of inflammatory mediators (Pruneau et al. 2010). Pouliot et al. reported that retinal plasma extravasation and RVP were significantly increased in the diabetic retina, and these abnormalities were reversed to control levels when treated with one eye drop of the nonpeptide B1R antagonist LF22-0542. These reports indicated that both local and systemic administrations of B1R antagonists are effective in ameliorating retinal vascular abnormalities in diabetic rodents, which are similar to the findings observed using PK inhibitors (Pouliot et al. 2012).

---

## Protective Factors

It has become clear from the clinical observational studies in patients with long duration of diabetes that factors may play a protective role on the function and survival of vascular cells involved in the microvascular complications of diabetes, which may be equally as important as metabolic toxic factors. In the Medalist Study from the Joslin Diabetes Center, we reported that more than 35% of a large group of insulin-requiring diabetic patients with disease duration of 50 years or longer were free from significant retinal and renal dysfunction (Keenan et al. 2007; Sun et al. 2011). The presence of microvascular complications did not correlate with glycemic control, suggesting the presence of endogenous protective factors in this unusual group of patients with diabetes of extreme duration. The possibility that endogenous protective factors are common in the general population of patients with diabetes is supported by the finding that over half of diabetic patients with microalbuminuria have regression of this marker over 6 years of follow-up (Perkins et al. 2003). Some factors with well-established functions have only recently been perceived as protective. In this section, we are summarizing some well-known and potentially protective factors (Fig. 2).

## Insulin: Concept of Selective Insulin Resistance on the Vessel Wall in Diabetes

Insulin receptors are present on all vascular cells and cells recruited to the vascular wall, among them endothelial cells, vascular smooth muscle cells, pericytes, macrophages, and all the glomerular cells. Insulin signal transduction in these cells is primarily by the activation of IRS1/2 and the PI3 kinase/Akt pathway, which has been shown to phosphorylate eNOS (p-eNOS), induce the expression of VEGF, endothelin-B receptors (ETBR) and heme oxygenase-1 (HO-1), and the down-regulation of VCAM-1 (Geraldès et al. 2008; Jiang et al. 2003; Park et al. 2016;

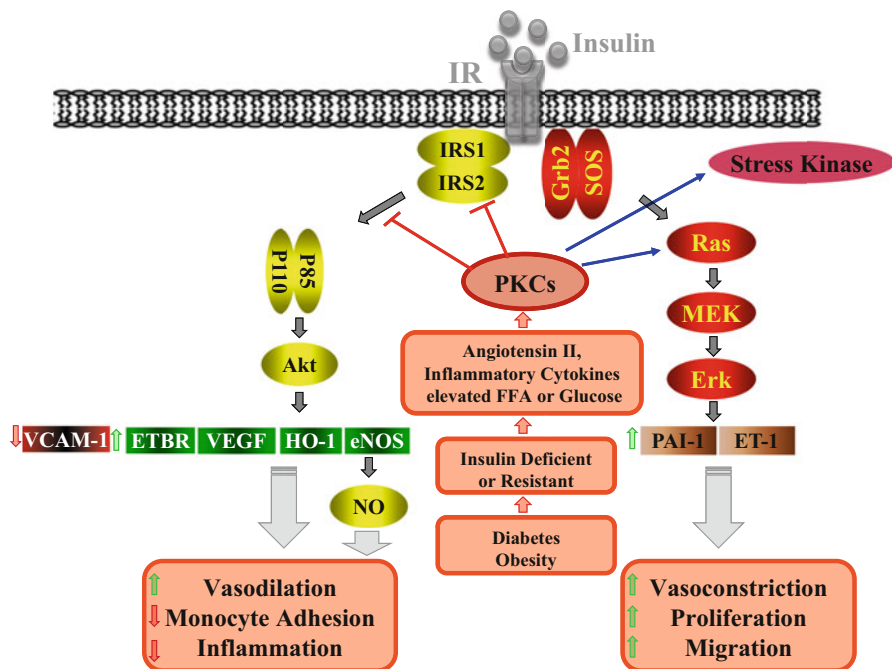

**Fig. 3** Selective insulin resistance in vascular endothelial cells. *IR* insulin receptor, *VCAM-1* vascular cell adhesion molecule-1, *FFA* free fatty acid, *ETBR* endothelin receptor type B, *eNOS* endothelial nitric oxide synthase, *NO* nitric oxide, *PAI-1* plasminogen activator inhibitor-1, and *ET-1* endothelin-1

Rask-Madsen et al. 2010). In addition, insulin can activate Src/MAPK pathway at higher concentrations to induce the expression of ET-1, migration, and perhaps proliferation of vascular contractile cells (Rask-Madsen and King 2013). In diabetes or insulin resistance, hyperglycemia or free fatty acids (FFA) have been reported to activate PKC $\alpha$ ,  $\beta$ , or  $\delta$  to phosphorylate IRS2 and p85/PI3K and inhibit p-Akt pathway to cause selective insulin resistance (IR) on the vessel wall with the loss of insulin's anti-inflammatory and antioxidative effects (Rask-Madsen and King 2013) (Fig. 3). In contrast, insulin activation of the MAP kinase pathway is not inhibited. In the kidney, podocytes are critically important for maintaining the integrity of the glomerular filtration barrier and preventing albuminuria. Insulin receptor signaling has a surprisingly profound effect on podocyte survival. Knockout of the insulin receptor targeted to podocytes (Welsh et al. 2010) induced the development of albuminuria, effacement of podocyte foot processes, and increased apoptosis together with more deposition of basal membrane components. Some of these glomerular pathologies were similar to those observed in diabetic nephropathy. One explanation for the importance of insulin on podocytes and glomerular function is its effect to increase expression of VEGF in several cell types, including podocytes (Hale et al. 2013). Normally, insulin upregulates VEGF expression, mostly via the IRS/Akt pathway, which in turn could act as a survival factor by autocrine or paracrine

signaling to podocytes, endothelial cells, and mesangial cells. Recently, Hale et al. reported that insulin directly increased VEGF-A mRNA levels and protein production in podocytes. Furthermore, when podocytes were rendered insulin resistant *in vivo* using transgenic podocyte-specific insulin receptor knockout mice, podocyte VEGF-A production was impaired (Hale et al. 2013). Insulin could prevent apoptosis by other mechanisms, including inhibition of the proapoptotic molecule caspase-9 (Hermann et al. 2000) inhibiting the transcription factor FoxO (Tsuchiya et al. 2012) or upregulation of antioxidant activity of HO-1 (Geraldes and King 2010).

Selective impairment of insulin action via IRS1/pI3K/Akt pathway on glomeruli has been described in diabetic animals and patients and may contribute to the development of diabetic nephropathy. Many of insulin's protective effects are mediated via the IRS/PI3K/Akt pathway, including upregulation of eNOS (Artwohl et al. 2007; Wang et al. 2009) and HO-1 (Geraldes and King 2010).

Recently, we have reported that insulin can also increase the expression of ETBR in the endothelial cells via the activation of IRS1/Akt pathway. This finding could be important for improving endothelial function since ETB receptors can enhance the activation of eNOS via the calmodulin pathway identifying a new mechanism by which insulin can enhance the activation of eNOS and NO production (Park et al. 2016). Since endothelial dysfunction could be important for both the pathogenesis of DR and DN, it is likely that insulin's actions on ETB and NO production will have important functions in the retina and glomeruli. For example, activation of ETB receptors in the retinal capillaries is known to increase retinal blood flow which could be important for the delay of progression of DR. In addition, it has been reported that the loss of eNOS function will accelerate and worsen the diabetic nephropathy in several rodent models of DN (Kanetsuna et al. 2007; Nakagawa et al. 2007; Zhao et al. 2006). In contrast, some mechanisms of injury stimulated by insulin are mediated by the Ras/MAPK pathway, such as induction of ET-1 (Oliver et al. 1991). In diabetes or insulin resistance, elevated concentrations of glucose and FFA can activate PKC, causing selective inhibition of insulin signaling through the PI3K pathway (Naruse et al. 2006). Certain threonine/serine residues on IRS2 and on the p85 regulatory subunit of PI3K have recently been identified as substrates for PKC, and phosphorylation of these sites inhibits insulin-stimulated PI3K signaling (Maeno et al. 2012; Park et al. 2013). Hyperinsulinemia in T2D could conceivably promote vascular disease through induction of ET-1 (Motawi et al. 2014) or other factors induced by MAPK signaling. Insulin may also be important in the retina and promote the maturation and survival of photoreceptors in the murine retina. Deletion of IRS2 leads to loss of neural retinal cell layers in IRS2 knockout mice (Yi et al. 2005). Insulin signaling and its activation of eNOS have been reported in the retina of rodents, which appears to diminish in the presence of diabetes.

## Antioxidant Enzymes

There is an enormous number of studies supporting the role of oxidative stress in the development of vascular complications (see previous section on "Oxidative Stress").

However, almost all of the clinical trials using antioxidants have not shown efficacy with clinically significant vascular endpoints. Nevertheless, it is likely that tissue specific endogenous antioxidant enzymes are important to neutralize the increased levels of oxidants produced by the enzymatic and nonenzymatic metabolisms of hyperglycemia. This idea has stimulated clinical trials using bardoxolone methyl (BARD), a synthetic triterpenoid that potentially can reduce oxidative stress and inflammation (Ruiz et al. 2013). One of the main mechanisms of action for this drug is to activate Nrf2. This nuclear factor upregulates a gene program of molecules with antioxidant activity called phase 2 genes, including HO-1 and enzymes in the glutathione biosynthesis pathway. Nrf2 translocation to the nucleus is inhibited by kelch-like ECH-associated protein 1 (Keap1), a repressor which binds Nrf2 in the cytoplasm and promotes Nrf2 proteasomal degradation. BARD interacts with cysteine residues on Keap1, making it unable to repress Nrf2, which then activates transcription of phase 2 genes. Results from a trial of BARD in patients with advanced chronic kidney disease showed an improvement in GFR up to 1 year after start of treatment (de Zeeuw et al. 2013b). However, proteinuria was increased and phase III trials were stopped due to safety issues. In the retina, Nrf2 was also reported to have a protective role against neuronal and capillary degeneration in retinal ischemia-reperfusion injury (I/R). I/R resulted in an increase in retinal levels of superoxide and proinflammatory mediators, as well as leukocyte infiltration of the retina and vitreous, in Nrf2 (+/+) mice. These pathologies were greatly accentuated in Nrf2 (-/-) mice (Wei et al. 2011).

### **SHP-1 Activation and Its Inhibitory Effects of PDGF and VEGF**

Biochemical explanations by which hyperglycemia inhibits endogenous protective factors activities have been reported for PDGF and VEGF, in pericytes in the retina and podocytes in the glomeruli, respectively (Geraldes et al. 2009; Mima et al. 2012) (Fig. 4). PDGF expressed by retinal endothelial cells plays a role both in vascular cell survival and proliferative retinopathy (Lei et al. 2010). During sprouting of angiogenesis, PDGF is produced by endothelial tip cells and acts through PDGF receptor- $\beta$  expressed by pericytes. This signal recruits pericytes to develop blood vessels. Pericytes, in turn, can support endothelial cell survival and inhibit its proliferation. This is demonstrated by findings in PDGF knockout mouse embryos, which show pericyte loss and endothelial cell proliferation (Lindahl et al. 1997). Mice with heterozygous deletion of the PDGF gene have increased frequency of acellular capillaries, particularly after induction of diabetes, but also an increased tendency for retinal neovascularization during ischemic retinopathy (Hammes et al. 2002). Consistent with this, deletion of PDGF-B in neurons, another source of PDGF-B, does not alter pericyte coverage in the brain. As described above, we have reported that hyperglycemia can inhibit survival effects of PDGF by upregulation of SHP-1, which causes dephosphorylation of the PDGF receptor in pericytes and possibly also in podocytes (Geraldes et al. 2009).

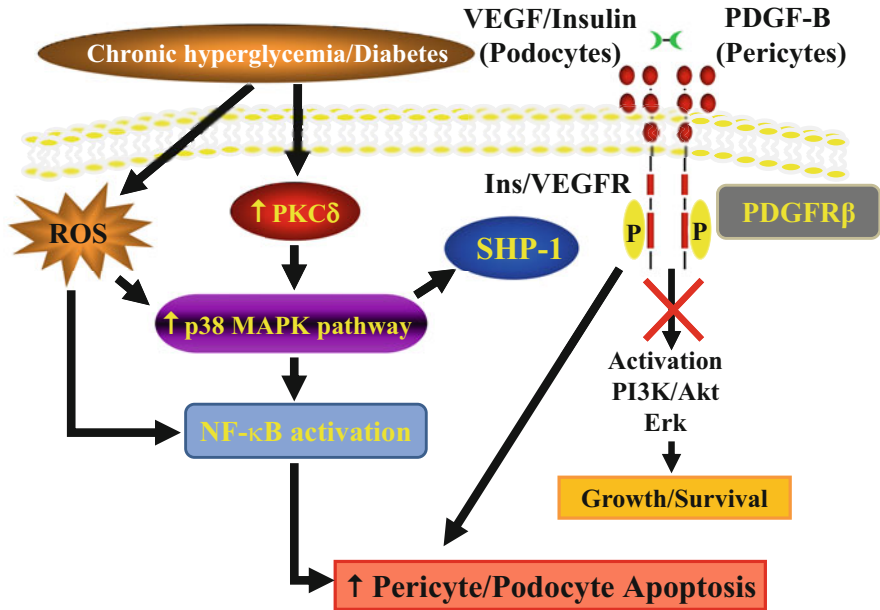

**Fig. 4** Hyperglycemia-induced apoptosis of key cells in the glomeruli and capillaries by dual pathways

During neurogenesis, PDGF is reported to play a critical role for maintenance of many specific neuronal cell types together with vascular cells. PDGF modulates neuronal excitability through adjusting various ion channels and affecting synaptic plasticity and function. Furthermore, PDGF stimulates survival signals, mainly via PI3K/Akt pathway but also other ways, rescuing cells from apoptosis (Funa and Sasahara 2014).

#### **Role of SHP-1 in the Development of Diabetic Microvascular Complications**

Diabetes and hyperglycemia, via PKCδ/p38MAPK, activates SHP-1, a tyrosine phosphatase in micro vessels including the retina and renal glomeruli (Fig. 4). This leads to the dephosphorylation and deactivation of specific growth factor receptors critical for survival of pericytes in the retina and podocytes in the kidney (Geraldès et al. 2009). In the retina, SHP-1 activation can desensitize pericytes to PDGF and cause pericyte apoptosis, an initiating step in the development of diabetic retinopathy (Geraldès et al. 2009). In the renal glomerular podocytes, impairment of VEGF survival signaling can be induced by upregulation of SHP-1 expression and lead to increased podocyte apoptosis and endothelial dysfunction (Mima et al. 2012). Upregulation of SHP-1 expression in diabetes is dependent upon activation of PKCδ and p38MAPKα (78, 86). The upregulation of p38MAPK and SHP-1 induced by diabetes is prevented in PKCδ knockout mice, which are protected from apoptosis of retinal pericytes, mesangial expansion, and albuminuria (Geraldès et al. 2009; Mima et al. 2012). Although retinal pericyte apoptosis induced by hyperglycemia has been

shown to involve activation of NF- $\kappa$ B, the increase of SHP-1 levels in the diabetic retina and glomerulus is independent of NF- $\kappa$ B activation (Geraldes et al., 2009; Mima et al. 2012). Therefore, inhibition of SHP-1 is a potential novel approach to preserve survival signaling in vascular cells.

## TGF- $\beta$

Expression of TGF- $\beta$  is increased in blood vessels, monocytes, heart, and many tissues in diabetes and has been viewed as a causative factor for development of fibrosis in the kidney (Ghosh et al. 2013). Administration of a neutralizing monoclonal TGF- $\beta$ 1 antibody to *db/db* mice decreases plasma TGF- $\beta$ 1, mesangial matrix expansion, and kidney mRNA levels of collagen IV and fibronectin (Ziyadeh et al. 2000). This therapy prevented a loss of renal function but had no effect on the elevated albuminuria. More recently, the TGF- $\beta$  receptor kinase activity inhibitor, GW788388, reduced glomerular collagen staining and kidney mRNA levels of PAI-1 and collagen (I and III) but did not alter albuminuria (Petersen et al. 2008). However, TGF- $\beta$  is well known to have potent anti-inflammatory effects on macrophages and is a negative regulator of T and B cells activation (Ruscetti et al. 1993). Therefore, it may have protective actions due to an anti-inflammatory effect, and its elevation is a reaction to the inflammatory stress of diabetes. Thus, it is likely that the overexpression of TGF- $\beta$  in many tissues by diabetes could be an endogenous response to the inflammatory actions of hyperglycemia in vascular cells. These paradoxical roles of TGF- $\beta$  are a challenge for using it as a drug target. Development of targeted nanoparticles or other means of tissue-specific drug delivery may allow inhibition of TGF- $\beta$  signaling in the kidney and not increase inflammatory actions in other tissues. A recent clinical trial using anti-TGF- $\beta$  was not shown to delay or improve renal function in people with DN (Voelker et al. 2017).

## VEGF

The expressions of VEGF are changed paradoxically by diabetes, with increases in the retina and renal glomeruli but decreases in the myocardium, peripheral limbs, and nerves correlating with the extent of angiogenesis (Aiello et al. 1994; Chou et al. 2002). Neutralization of VEGF is already approved treatment for proliferative diabetic retinopathy and macular edema and has been suggested as a therapy for diabetic nephropathy (Chen and Ziyadeh 2008). However, the increased levels of VEGF in both tissues are likely an appropriate response to hypoxia, which are the results of loss of capillary function induced by hyperglycemia in the retina. It has been a long-standing concern that neutralization of VEGF could counteract survival signaling in retinal neurons. Interestingly, injection of low doses of VEGF accelerated restoration of the physiological capillary bed and prevented preretinal neovascularization (Dorrell et al. 2010).



The highest expression level of VEGF in the kidney is in renal podocytes, and some of the most insightful work describing a role for VEGF as a survival factor in any organ susceptible to diabetes complications has been done in renal podocytes. Conditional deletion of VEGF in podocytes resulted in a complete lack of endothelial and mesangial cells in mature glomeruli and death within the first day of life (Eremina et al. 2003). This finding strongly supports a role for VEGF in the maintenance of glomerular endothelial cells. Heterozygous knockout of VEGF in podocytes resulted in proteinuria and end-stage renal failure (Eremina et al. 2003) and was preceded by disappearance of endothelial cell fenestrations, increase in necrosis, effacement of podocyte foot processes, and a dramatic loss of mesangial cells (Eremina et al. 2003). When diabetes was induced with STZ in these mice, glomerular cell apoptosis, glomerulosclerosis, and proteinuria were exacerbated compared with nondiabetic controls (Sivaskandarajah et al. 2012). However, other studies reported that increased podocyte VEGF<sub>164</sub> expression worsens diabetic nephropathy characterized by glomerulosclerosis, microaneurysms, mesangiolysis, glomerular basement membrane thickening, podocyte effacement, and massive proteinuria associated with hyperfiltration (Veron et al. 2011).

VEGF also has been reported to have neuroprotective effects: Primary dorsal root ganglion (DRG) cultures lacking VEGF-B or VEGFR-1 (FLT1) exhibited increased neuronal stress and were more susceptible to paclitaxel-induced cell death. Concurrently, mice lacking VEGF-B or a functional FLT1 developed more retrograde degeneration of sensory neurons of distal neuropathy. On the other hand, the addition of the VEGF-B isoform, VEGF-B (Chen and Ziyadeh 2008), to DRG cultures antagonized neuronal stress, maintained the mitochondrial membrane potential, and stimulated neuronal survival. Mice overexpressing VEGF-B (Chen and Ziyadeh 2008) or FLT1 selectively in neurons were protected against distal neuropathy, whereas exogenous VEGF-B (Chen and Ziyadeh 2008), either delivered by gene transfer or as a recombinant factor, was protective by directly affecting sensory neurons and not the surrounding vasculature (Dhondt et al. 2011). Identifying the prosurvival mechanisms in stressed neuronal cells revealed that protein kinase A functioned concurrently with VEGFR2 pathway to signal the activation of the extracellular signal-regulated protein kinases (ERK1/2) as protection against caspase-3/7 activation and subsequent cell death (Gomes et al. 2007).

### **Activated Protein C (APC)**

Protein C is a well-known anticoagulant factor but more recently was recognized as a survival factor for renal glomerular cells (Isermann et al. 2007). Thrombomodulin, a procoagulant factor which activates protein C, was found to be highly expressed in glomeruli of mice but was downregulated in diabetes (Isermann et al. 2007). Diabetic mice with a loss-of-function thrombomodulin gene mutation had more albuminuria and more severe glomerular pathology than diabetic wild-type mice, whereas diabetic mice with a gain-of-function mutation of the protein C gene had

less albuminuria and glomerular pathology (Isermann et al. 2007). The anticoagulant effects of APC did not account for its protective actions. Rather, APC was shown to counteract apoptosis of endothelial cells and podocytes through activation of two of its receptors (Isermann et al. 2007). Therefore, endothelial-derived APC appears to be a protective factor with local survival effects for both podocytes and endothelial cells in the glomerulus. The underlying mechanism for APC protection from renal dysfunction is still unknown, but Gupta et al. reported that APC-mediated protease activated receptor-1 agonism suppressed lipopolysaccharides (LPS)-induced increases in the vasoactive peptide adrenomedullin and infiltration of iNOS-positive leukocytes into renal tissue. The anticoagulant function of APC was responsible for suppressing LPS-induced stimulation of the proinflammatory mediators ACE-1, IL-6, and IL-18, perhaps accounting for its ability to modulate renal hemodynamics (Gupta et al. 2009).

### **Vascular Progenitor Cells (VPC)**

Endothelial progenitor cells (EPC) and myeloid progenitors may contribute to postnatal angiogenesis (Bautch 2011). Recent report from the Joslin Medalist Study showed that circulating VPC levels were correlated to CVD in the Medalists and higher than aged-matched T2DM patients and comparable to nondiabetic controls, again suggesting that circulating VPC either are markers of vascular complications or may even contribute to the levels of functions of vascular cells against the adverse effects of diabetes (Hernandez et al. 2014). The mechanism for EPC to improve angiogenesis is currently not well characterized. EPC may contribute by incorporating into newly formed blood vessels. However, it is likely the major action of EPC is to release proangiogenic factors and temporarily associate with neovascular structures. In diabetic patients, both the number and function of EPC are impaired (Loomans et al. 2004) leading to a subsequent reduction in the ability of EPC to repair the vascular endothelium (Jarajapu and Grant 2010), leading to poor collateral circulation in response to ischemia. eNOS is necessary for mobilization of EPC from the bone marrow, as this phenomenon is impaired in eNOS knockout mice (Aicher et al. 2003). Uncoupling of eNOS, with synthesis of superoxide rather than NO by eNOS, could be one mechanism for impaired EPC function. In fact, EPC function is improved after inhibition of eNOS *ex vivo* in EPC isolated from patients with diabetes (Thum et al. 2007). Interestingly, neuropathy in the bone marrow may cause reduced mobilization of EPC. Thus, diabetic rats had a reduction in nerve terminals in bone marrow and this denervation resulted in an increased number of EPC in the bone marrow, but decreased release of EPC to the circulation. These abnormalities were associated with an increase in retinal acellular capillaries (Busik et al. 2009). Transplantation of nondiabetic EPC has been shown to improve angiogenesis in peripheral ischemia (Yan et al. 2009). These studies suggest that it may be possible to promote repair of ischemic tissue in diabetes by improving mobilization, differentiation, and function of EPC or other progenitors. Recently, autologous EPC transplantation has been suggested as a potential therapy for

DN. An alternative approach is the stimulation of endogenous bone-marrow-derived EPC (BM-EPC) recruitment into ischemic lesions by the administration of stem cell mobilization agents or chemokines (Kim et al. 2013). The administration of AMD3100, an EPC mobilization agent, increased local expression levels of vasculogenesis-associated factors and newly formed endothelial cells in the sciatic nerve, resulting in the restoration of the sciatic vasa nervorum (Kim et al. 2013).

Circulating EPC were markedly reduced in chronic kidney disease (CKD) patients (Chen et al. 2013), and EPC delivery has been shown to improve renal function, attenuate the proinflammatory response associated with renal injury, and improve damage to tubules and renal vascular segments during kidney injury while providing enhanced neoangiogenesis (Kale et al. 2003). An intact and healthy EPC niche, residing in the bone marrow but also found locally in renal vascular beds such as in the area of the adventitia layer of vessels, may be able to support normal vascular function including maintenance and possible replacement of the endothelium (Minamino et al. 2002).

Emerging studies suggest the potential of these cells in revascularization of ischemic and injured retinas in animal models of retinal disease. Since ischemic retinopathies are leading causes of blindness, they are a potential disease target for EPC-based therapy (Li Calzi et al. 2010). In NPDR, EPC may have reduced function as they cannot recruit outgrowth of EPC into the retina to repair the acellular capillaries, while in PDR the EPC take on a proinflammatory phenotype and recruit too many EPC leading to pathological neovascularization.

For the last 10 years, many groups have focused on understanding the basic mechanism responsible for the diabetes-associated defect in EPC function. Correcting this defect may allow the use of a diabetic patient's own EPC for repair of their injured retinal and systemic vasculature. Specifically in the retina, correction of this dysfunction may prevent early and intermediate stages of vasodegeneration to enhance vessel repair, reverse ischemia, and prevent progression to the late stages of DR. However, these findings on the changes of EPC and their correlation to various complications in diabetes have been inconsistent. Clearly, more studies are needed to clarify their roles and changes in diabetes before they can be used therapeutically.

---

## Summary

Human and animal data have confirmed the long-held belief that hyperglycemia impairs microvascular cell survival and function. Multiple molecular and biochemical mechanisms have been proposed to explain the pathogenesis of hyperglycemia's toxic effects. From the review of the literature, it is likely that the initiation of hyperglycemia's adverse effects is due to increases of its metabolites or flux in the vascular cells, which can cause specific changes in the vascular functions such as those mediated by PKC activation or mitochondrial dysfunction. However, increases in glucose metabolism can also generate nondiabetic specific toxic products such as

oxidants, AGE, and methylglyoxal, which will accelerate the specific toxic actions of hyperglycemia to cause microvascular pathologies. The specific pathologies manifested by each tissue such as the retina, glomeruli, and the peripheral neuron are modulated by the specific needs of these tissues, the importance of the various functions that are changed by hyperglycemia, and the protective responses generated by each tissue (Fig. 2). The role of tissue protection has gained greater prominence than before in the establishment of microvessel complications of diabetes. Thus, treatment to prevent and delay the progression of diabetic microvascular complications depends on:

1. Elimination of hyperglycemia
2. Inhibition of major mechanisms, which are activated by hyperglycemia to induce vascular dysfunction
3. Neutralization of accelerants such as inflammation and oxidative stress
4. Activation of tissue-specific protective factors

**Acknowledgment** The authors would like to acknowledge funding from the Juvenile Diabetes Research Foundation grant 17-2011-474, National Institutes of Health grants 5 R01 DK053105-12, 5 R24 DK090961-02, 1 DP3 DK094333-01, NIH Diabetes Research Center 2 P30 DK036836-26A1, ADA mentor-based fellowship.

---

## References

- Abdoun M, Khanjari A, Abdelaziz N, Ongali B, Couture R, Hassessian HM. Early upregulation of kinin B1 receptors in retinal microvessels of the streptozotocin-diabetic rat. *Br J Pharmacol*. 2003;140:33–40.
- Abdoun M, Talbot S, Couture R, Hassessian HM. Retinal plasma extravasation in streptozotocin-diabetic rats mediated by kinin B(1) and B(2) receptors. *Br J Pharmacol*. 2008;154:136–43.
- Aicher A, Brenner W, Zuhayra M, Badorf C, Massoudi S, Assmus B, Eckey T, Henze E, Zeiher AM, Dimmeler S. Assessment of the tissue distribution of transplanted human endothelial progenitor cells by radioactive labeling. *Circulation*. 2003;107:2134–9.
- Aiello LM, Cavallerano J. Diabetic retinopathy. *Curr Ther Endocrinol Metab*. 1997;6:475–85.
- Aiello LP, Avery RL, Arrigg PG, Keyt BA, Jampel HD, Shah ST, Pasquale LR, Thieme H, Iwamoto MA, Park JE, et al. Vascular endothelial growth factor in ocular fluid of patients with diabetic retinopathy and other retinal disorders. *N Engl J Med*. 1994;331:1480–7.
- Aiello LP, Gardner TW, King GL, Blankenship G, Cavallerano JD, Ferris FL 3rd, Klein R. Diabetic retinopathy. *Diabetes Care*. 1998;21:143–56.
- Aiello LP, Davis MD, Girach A, Kles KA, Milton RC, Sheetz MJ, Vignati L, Zhi XE. Effect of ruboxistaurin on visual loss in patients with diabetic retinopathy. *Ophthalmology*. 2006;113:2221–30.
- Aiello LP, Vignati L, Sheetz MJ, Zhi X, Girach A, Davis MD, Wolka AM, Shahri N, Milton RC. Oral protein kinase c beta inhibition using ruboxistaurin: efficacy, safety, and causes of vision loss among 813 patients (1,392 eyes) with diabetic retinopathy in the Protein Kinase C beta Inhibitor-Diabetic Retinopathy Study and the Protein Kinase C beta Inhibitor-Diabetic Retinopathy Study 2. *Retina*. 2011;31:2084–94.
- Araki S, Haneda M, Sugimoto T, Isono M, Isshiki K, Kashiwagi A, Koya D. Polymorphisms of the protein kinase C-beta gene (PRKCB1) accelerate kidney disease in type 2 diabetes without overt proteinuria. *Diabetes Care*. 2006;29:864–8.

- Artwohl M, Brunmair B, Furnsinn C, Holzenbein T, Rainer G, Freudenthaler A, Prosd EM, Huttary N, Baumgartner-Parzer SM. Insulin does not regulate glucose transport and metabolism in human endothelium. *Eur J Clin Invest*. 2007;37:643–50.
- Ayo SH, Radnik R, Garoni JA, Troyer DA, Kreisberg JJ. High glucose increases diacylglycerol mass and activates protein kinase C in mesangial cell cultures. *Am J Phys*. 1991;261:F571–7.
- Babaei-Jadidi R, Karachalias N, Ahmed N, Battah S, Thornalley PJ. Prevention of incipient diabetic nephropathy by high-dose thiamine and benfotiamine. *Diabetes*. 2003;52:2110–20.
- Babazono T, Kapor-Drezgic J, Dlugosz JA, Whiteside C. Altered expression and subcellular localization of diacylglycerol-sensitive protein kinase C isoforms in diabetic rat glomerular cells. *Diabetes*. 1998;47:668–76.
- Bautch VL. Stem cells and the vasculature. *Nat Med*. 2011;17:1437–43.
- Boyd A, Casselini C, Vinik E, Vinik A. Quality of life and objective measures of diabetic neuropathy in a prospective placebo-controlled trial of ruboxistaurin and topiramate. *J Diabetes Sci Technol*. 2011;5:714–22.
- Brovkovich V, Zhang Y, Brovkovich S, Minshall RD, Skidgel RA. A novel pathway for receptor-mediated post-translational activation of inducible nitric oxide synthase. *J Cell Mol Med*. 2011;15:258–69.
- Brownlee M. Biochemistry and molecular cell biology of diabetic complications. *Nature*. 2001;414:813–20.
- Burg MB, Kador PF. Sorbitol, osmoregulation, and the complications of diabetes. *J Clin Invest*. 1988;81:635–40.
- Burnier M, Zanchi A. Blockade of the renin-angiotensin-aldosterone system: a key therapeutic strategy to reduce renal and cardiovascular events in patients with diabetes. *J Hypertens*. 2006;24:11–25.
- Bursell SE, Takagi C, Clermont AC, Takagi H, Mori F, Ishii H, King GL. Specific retinal diacylglycerol and protein kinase C beta isoform modulation mimics abnormal retinal hemodynamics in diabetic rats. *Invest Ophthalmol Vis Sci*. 1997;38:2711–20.
- Busik JV, Tikhonenko M, Bhatwadekar A, Opreanu M, Yakubova N, Caballero S, Player D, Nakagawa T, Afzal A, Kielczewski J, Sochacki A, Hasty S, Li Calzi S, Kim S, Duclax SK, Segal MS, Guberski DL, Esselman WJ, Boulton ME, Grant MB. Diabetic retinopathy is associated with bone marrow neuropathy and a depressed peripheral clock. *J Exp Med*. 2009;206:2897–906.
- Busse R, Fleming I. Molecular responses of endothelial tissue to kinins. *Diabetes*. 1996; 45(Suppl 1):S8–13.
- Cameron NE, Cotter MA. Effects of protein kinase Cbeta inhibition on neurovascular dysfunction in diabetic rats: interaction with oxidative stress and essential fatty acid dysmetabolism. *Diabetes Metab Res Rev*. 2002;18:315–23.
- Cameron NE, Eaton SE, Cotter MA, Tesfaye S. Vascular factors and metabolic interactions in the pathogenesis of diabetic neuropathy. *Diabetologia*. 2001;44:1973–88.
- Casellini CM, Barlow PM, Rice AL, Casey M, Simmons K, Pittenger G, Bastyr EJ 3rd, Wolka AM, Vinik AI. A 6-month, randomized, double-masked, placebo-controlled study evaluating the effects of the protein kinase C-beta inhibitor ruboxistaurin on skin microvascular blood flow and other measures of diabetic peripheral neuropathy. *Diabetes Care*. 2007;30:896–902.
- Catanzaro O, Labal E, Andornino A, Capponi JA, Di Martino I, Sirois P. Blockade of early and late retinal biochemical alterations associated with diabetes development by the selective bradykinin B1 receptor antagonist R-954. *Peptides*. 2012;34:349–52.
- Chen S, Ziyadeh FN. Vascular endothelial growth factor and diabetic nephropathy. *Curr Diab Rep*. 2008;8:470–6.
- Chen CY, Abell AM, Moon YS, Kim KH. An advanced glycation end product (AGE)-receptor for AGEs (RAGE) axis restores adipogenic potential of senescent preadipocytes through modulation of p53 protein function. *J Biol Chem*. 2012;287:44498–507.
- Chen YT, Cheng BC, Ko SF, Chen CH, Tsai TH, Leu S, Chang HW, Chung SY, Chua S, Yeh KH, Chen YL, Yip HK. Value and level of circulating endothelial progenitor cells, angiogenesis

- factors and mononuclear cell apoptosis in patients with chronic kidney disease. *Clin Exp Nephrol.* 2013;17:83–91.
- Chou E, Suzuma I, Way KJ, Opland D, Clermont AC, Naruse K, Suzuma K, Bowling NL, Vlahos CJ, Aiello LP, King GL. Decreased cardiac expression of vascular endothelial growth factor and its receptors in insulin-resistant and diabetic states: a possible explanation for impaired collateral formation in cardiac tissue. *Circulation.* 2002;105:373–9.
- Clermont A, Chilcote TJ, Kita T, Liu J, Riva P, Sinha S, Feener EP. Plasma kallikrein mediates retinal vascular dysfunction and induces retinal thickening in diabetic rats. *Diabetes.* 2011;60:1590–8.
- Cotter MA, Cameron NE. Effect of the NAD(P)H oxidase inhibitor, apocynin, on peripheral nerve perfusion and function in diabetic rats. *Life Sci.* 2003;73:1813–24.
- Danis RP, Bingaman DP, Jirousek M, Yang Y. Inhibition of intraocular neovascularization caused by retinal ischemia in pigs by PKC $\beta$  inhibition with LY333531. *Invest Ophthalmol Vis Sci.* 1998;39:171–9.
- de Zeeuw D, Akizawa T, Audhya P, Bakris GL, Chin M, Christ-Schmidt H, Goldsberry A, Houser M, Krauth M, Lambers Heerspink HJ, McMurray JJ, Meyer CJ, Parving HH, Remuzzi G, Toto RD, Vaziri ND, Wanner C, Wittes J, Wroldstad D, Chertow GM. Bardoxolone methyl in type 2 diabetes and stage 4 chronic kidney disease. *N Engl J Med.* 2013a;369:2492–503.
- de Zeeuw D, Akizawa T, Agarwal R, Audhya P, Bakris GL, Chin M, Krauth M, Lambers Heerspink HJ, Meyer CJ, McMurray JJ, Parving HH, Pergola PE, Remuzzi G, Toto RD, Vaziri ND, Wanner C, Warnock DG, Wittes J, Chertow GM. Rationale and trial design of bardoxolone methyl evaluation in patients with chronic kidney disease and type 2 diabetes: the occurrence of renal events (BEACON). *Am J Nephrol.* 2013b;37:212–22.
- Demaine AG. Polymorphisms of the aldose reductase gene and susceptibility to diabetic microvascular complications. *Curr Med Chem.* 2003;10:1389–98.
- Dhondt J, Peeraer E, Verheyen A, Nuydens R, Buyschaert I, Poesen K, Van Geyte K, Beerens M, Shibuya M, Haigh JJ, Meert T, Carmeliet P, Lambrechts D. Neuronal FLT1 receptor and its selective ligand VEGF-B protect against retrograde degeneration of sensory neurons. *FASEB J.* 2011;25:1461–73.
- Diabetes Control and Complications Trial (DCCT)/Epidemiology of Diabetes Interventions and Complications (EDIC) Study Research Group. Intensive diabetes treatment and cardiovascular outcomes in type 1 diabetes: The DCCT/EDIC study 30-year follow-up. *Diabetes Care.* 2016; 39:686–93.
- Dorrell MI, Aguilar E, Jacobson R, Trauger SA, Friedlander J, Siuzdak G, Friedlander M. Maintaining retinal astrocytes normalizes revascularization and prevents vascular pathology associated with oxygen-induced retinopathy. *Glia.* 2010;58:43–54.
- Du X, Matsumura T, Edelstein D, Rossetti L, Zsengeller Z, Szabo C, Brownlee M. Inhibition of GAPDH activity by poly(ADP-ribose) polymerase activates three major pathways of hyperglycemic damage in endothelial cells. *J Clin Invest.* 2003;112:1049–57.
- Dyck PJ, Kratz KM, Karnes JL, Litchy WJ, Klein R, Pach JM, Wilson DM, O'Brien PC, Melton LJ 3rd, Service FJ. The prevalence by staged severity of various types of diabetic neuropathy, retinopathy, and nephropathy in a population-based cohort: the Rochester Diabetic Neuropathy Study. *Neurology.* 1993;43:817–24.
- Eichberg J. Protein kinase C changes in diabetes: is the concept relevant to neuropathy? *Int Rev Neurobiol.* 2002;50:61–82.
- Remina V, Sood M, Haigh J, Nagy A, Lajoie G, Ferrara N, Gerber HP, Kikkawa Y, Miner JH, Quaggin SE. Glomerular-specific alterations of VEGF-A expression lead to distinct congenital and acquired renal diseases. *J Clin Invest.* 2003;111:707–16.
- Fallahzadeh MK, Dormanesh B, Sagheb MM, Roozbeh J, Vessal G, Pakfetrat M, Daneshbod Y, Kamali-Sarvestani E, Lankarani KB. Effect of addition of silymarin to renin-angiotensin system inhibitors on proteinuria in type 2 diabetic patients with overt nephropathy: a randomized, double-blind, placebo-controlled trial. *Am J Kidney Dis.* 2012;60:896–903.
- Feener EP, Zhou Q, Fickweiler W. Role of plasma kallikrein in diabetes and metabolism. *Thromb Haemost.* 2013;110:434–41.

- Fleming TH, Humpert PM, Nawroth PP, Bierhaus A. Reactive metabolites and AGE/RAGE-mediated cellular dysfunction affect the aging process: a mini-review. *Gerontology*. 2011;57:435–43.
- Foster MC, Hwang SJ, Larson MG, Lichtman JH, Parikh NI, Vasani RS, Levy D, Fox CS. Overweight, obesity, and the development of stage 3 CKD: the Framingham Heart Study. *Am J Kidney Dis*. 2008;52:39–48.
- Fu ZJ, Li SY, Kociok N, Wong D, Chung SK, Lo AC. Aldose reductase deficiency reduced vascular changes in neonatal mouse retina in oxygen-induced retinopathy. *Invest Ophthalmol Vis Sci*. 2012;53:5698–712.
- Funa K, Sasahara M. The roles of PDGF in development and during neurogenesis in the normal and diseased nervous system. *J Neuroimmune Pharmacol*. 2014;9:168–81.
- Gabbay KH. The sorbitol pathway and the complications of diabetes. *N Engl J Med*. 1973;288:831–6.
- Garcia Soriano F, Virag L, Jagtap P, Szabo E, Mabley JG, Liaudet L, Marton A, Hoyt DG, Murthy KG, Salzman AL, Southan GJ, Szabo C. Diabetic endothelial dysfunction: the role of poly (ADP-ribose) polymerase activation. *Nat Med*. 2001;7:108–13.
- Geraldes P, King GL. Activation of protein kinase C isoforms and its impact on diabetic complications. *Circ Res*. 2010;106:1319–31.
- Geraldes P, Yagi K, Ohshiro Y, He Z, Maeno Y, Yamamoto-Hiraoka J, Rask-Madsen C, Chung SW, Perrella MA, King GL. Selective regulation of heme oxygenase-1 expression and function by insulin through IRS1/phosphoinositide 3-kinase/Akt-2 pathway. *J Biol Chem*. 2008;283:34327–36.
- Geraldes P, Hiraoka-Yamamoto J, Matsumoto M, Clermont A, Leitges M, Marette A, Aiello LP, Kern TS, King GL. Activation of PKC-delta and SHP-1 by hyperglycemia causes vascular cell apoptosis and diabetic retinopathy. *Nat Med*. 2009;15:1298–306.
- Ghosh AK, Quaggin SE, Vaughan DE. Molecular basis of organ fibrosis: potential therapeutic approaches. *Exp Biol Med (Maywood)*. 2013;238:461–81.
- Girolami A, Tezza F, Scandellari R, Vettore S, Girolami B. Associated prothrombotic conditions are probably responsible for the occurrence of thrombosis in almost all patients with congenital FVII deficiency. Critical review of the literature. *J Thromb Thrombolysis*. 2010;30:172–8.
- Goldberg T, Cai W, Peppas M, Dardaine V, Baliga BS, Uribarri J, Vlassara H. Advanced glycoxidation end products in commonly consumed foods. *J Am Diet Assoc*. 2004;104:1287–91.
- Goldin A, Beckman JA, Schmidt AM, Creager MA. Advanced glycation end products: sparking the development of diabetic vascular injury. *Circulation*. 2006;114:597–605.
- Gomes E, Papa L, Hao T, Rockwell P. The VEGFR2 and PKA pathways converge at MEK/ERK1/2 to promote survival in serum deprived neuronal cells. *Mol Cell Biochem*. 2007;305:179–90.
- Gupta A, Gerlitz B, Richardson MA, Bull C, Berg DT, Syed S, Galbreath EJ, Swanson BA, Jones BE, Grinnell BW. Distinct functions of activated protein C differentially attenuate acute kidney injury. *J Am Soc Nephrol*. 2009;20:267–77.
- Hale LJ, Hurcombe J, Lay A, Santamaria B, Valverde AM, Saleem MA, Mathieson PW, Welsh GI, Coward RJ. Insulin directly stimulates VEGF-A production in the glomerular podocyte. *Am J Physiol Ren Physiol*. 2013;305:F182–8.
- Hamilton RT, Bhattacharya A, Walsh ME, Shi Y, Wei R, Zhang Y, Rodriguez KA, Buffenstein R, Chaudhuri AR, Van Remmen H. Elevated protein carbonylation, and misfolding in sciatic nerve from db/db and Sod1(–/–) mice: plausible link between oxidative stress and demyelination. *PLoS One*. 2013;8:e65725.
- Hammes HP, Lin J, Renner O, Shani M, Lundqvist A, Betsholtz C, Brownlee M, Deutsch U. Pericytes and the pathogenesis of diabetic retinopathy. *Diabetes*. 2002;51:3107–12.
- Han T, Bai J, Liu W, Hu Y. A systematic review and meta-analysis of alpha-lipoic acid in the treatment of diabetic peripheral neuropathy. *Eur J Endocrinol*. 2012;167:465–71.
- Harindhanavudhi T, Mauer M, Klein R, Zinman B, Sinaiko A, Caramori ML. Benefits of Renin-Angiotensin blockade on retinopathy in type 1 diabetes vary with glycemic control. *Diabetes Care*. 2011;34:1838–42.
- Haritoglou C, Gerss J, Hammes HP, Kampik A, Ulbig MW. Alpha-lipoic acid for the prevention of diabetic macular edema. *Ophthalmologica*. 2011;226:127–37.

- Hempel A, Maasch C, Heintze U, Lindschau C, Dietz R, Luft FC, Haller H. High glucose concentrations increase endothelial cell permeability via activation of protein kinase C alpha. *Circ Res*. 1997;81:363–71.
- Hermann C, Assmus B, Urbich C, Zeiher AM, Dimmeler S. Insulin-mediated stimulation of protein kinase Akt: a potent survival signaling cascade for endothelial cells. *Arterioscler Thromb Vasc Biol*. 2000;20:402–9.
- Hernandez SL, Gong JH, Chen L, Wu IH, Sun JK, Keenan HA, King GL. Characterization of circulating and endothelial progenitor cells in patients with extreme-duration type 1 diabetes. *Diabetes Care*. 2014;37:2193–201.
- Hink U, Li H, Mollnau H, Oelze M, Matheis E, Hartmann M, Skatchkov M, Thaiss F, Stahl RA, Warnholtz A, Meinertz T, Griendling K, Harrison DG, Forstermann U, Munzel T. Mechanisms underlying endothelial dysfunction in diabetes mellitus. *Circ Res*. 2001;88:E14–22.
- Hudson BI, Kalea AZ, Del Mar Arriero M, Harja E, Boulanger E, D'Agati V, Schmidt AM. Interaction of the RAGE cytoplasmic domain with diaphanous-1 is required for ligand-stimulated cellular migration through activation of Rac1 and Cdc42. *J Biol Chem*. 2008;283:34457–68.
- Ido Y, McHowat J, Chang KC, Arrigoni-Martelli E, Orfalian Z, Kilo C, Corr PB, Williamson JR. Neural dysfunction and metabolic imbalances in diabetic rats. Prevention by acetyl-L-carnitine. *Diabetes*. 1994;43:1469–77.
- Idris I, Gray S, Donnelly R. Protein kinase C activation: isozyme-specific effects on metabolism and cardiovascular complications in diabetes. *Diabetologia*. 2001;44:659–73.
- Inoguchi T, Battan R, Handler E, Sportsman JR, Heath W, King GL. Preferential elevation of protein kinase C isoform beta II and diacylglycerol levels in the aorta and heart of diabetic rats: differential reversibility to glycemic control by islet cell transplantation. *Proc Natl Acad Sci U S A*. 1992;89:11059–63.
- Inoguchi T, Li P, Umeda F, Yu HY, Kakimoto M, Imamura M, Aoki T, Etoh T, Hashimoto T, Naruse M, Sano H, Utsumi H, Nawata H. High glucose level and free fatty acid stimulate reactive oxygen species production through protein kinase C – dependent activation of NAD(P)H oxidase in cultured vascular cells. *Diabetes*. 2000;49:1939–45.
- Isermann B, Vinnikov IA, Madhusudhan T, Herzog S, Kashif M, Blautzik J, Corat MA, Zeier M, Blessing E, Oh J, Gerlitz B, Berg DT, Grinnell BW, Chavakis T, Esmon CT, Weiler H, Bierhaus A, Nawroth PP. Activated protein C protects against diabetic nephropathy by inhibiting endothelial and podocyte apoptosis. *Nat Med*. 2007;13:1349–58.
- Ishii H, Jirousek MR, Koya D, Takagi C, Xia P, Clermont A, Bursell SE, Kern TS, Ballas LM, Heath WF, Stramm LE, Feener EP, King GL. Amelioration of vascular dysfunctions in diabetic rats by an oral PKC beta inhibitor. *Science*. 1996;272:728–31.
- Jandeleit-Dahm KA, Lassila M, Allen TJ. Advanced glycation end products in diabetes-associated atherosclerosis and renal disease: interventional studies. *Ann N Y Acad Sci*. 2005;1043:759–66.
- Jarajapu YP, Grant MB. The promise of cell-based therapies for diabetic complications: challenges and solutions. *Circ Res*. 2010;106:854–69.
- Jeffery J, Jornvall H. Enzyme relationships in a sorbitol pathway that bypasses glycolysis and pentose phosphates in glucose metabolism. *Proc Natl Acad Sci U S A*. 1983;80:901–5.
- Jeppesen P, Aalkjaer C, Bek T. Bradykinin relaxation in small porcine retinal arterioles. *Invest Ophthalmol Vis Sci*. 2002;43:1891–6.
- Jiang ZY, He Z, King BL, Kuroki T, Opland DM, Suzuma K, Suzuma I, Ueki K, Kulkarni RN, Kahn CR, King GL. Characterization of multiple signaling pathways of insulin in the regulation of vascular endothelial growth factor expression in vascular cells and angiogenesis. *J Biol Chem*. 2003;278:31964–71.
- Jin Y, Ratnam K, Chuang PY, Fan Y, Zhong Y, Dai Y, Mazloom AR, Chen EY, D'Agati V, Xiong H, Ross MJ, Chen N, Ma'ayan A, He JC. A systems approach identifies HIPK2 as a key regulator of kidney fibrosis. *Nat Med*. 2012;18:580–8.
- Jing G, Wang JJ, Zhang SX. ER stress and apoptosis: a new mechanism for retinal cell death. *Exp Diabetes Res*. 2012;2012:589589.
- Jirousek MR, Gillig JR, Gonzalez CM, Heath WF, McDonald JH 3rd, Neel DA, Rito CJ, Singh U, Stramm LE, Melikian-Badalian A, Baevsky M, Ballas LM, Hall SE, Winneroski LL,



- Faul MM. (S)-13-[(dimethylamino)methyl]-10,11,14,15-tetrahydro-4,9:16, 21-dimetheno-1H, 13H-dibenzo[e,k]pyrrolo[3,4-h][1,4,13]oxadiazacyclohexadecene-1,3(2H)-dione (LY333531) and related analogues: isozyme selective inhibitors of protein kinase C beta. *J Med Chem.* 1996;39:2664–71.
- Kador PF, Betts D, Wyman M, Blessing K, Randazzo J. Effects of topical administration of an aldose reductase inhibitor on cataract formation in dogs fed a diet high in galactose. *Am J Vet Res.* 2006;67:1783–7.
- Kagami S, Border WA, Miller DE, Noble NA. Angiotensin II stimulates extracellular matrix protein synthesis through induction of transforming growth factor-beta expression in rat glomerular mesangial cells. *J Clin Invest.* 1994;93:2431–7.
- Kaiser N, Sasson S, Feener EP, Boukobza-Vardi N, Higashi S, Moller DE, Davidheiser S, Przybylski RJ, King GL. Differential regulation of glucose transport and transporters by glucose in vascular endothelial and smooth muscle cells. *Diabetes.* 1993;42:80–9.
- Kale S, Karihaloo A, Clark PR, Kashgarian M, Krause DS, Cantley LG. Bone marrow stem cells contribute to repair of the ischemically injured renal tubule. *J Clin Invest.* 2003;112:42–9.
- Kamata K, Sugiura M, Kasuya Y. Decreased Ca<sup>2+</sup> influx into the endothelium contributes to the decrease in endothelium-dependent relaxation in the aorta of streptozotocin-induced diabetic mice. *Res Commun Mol Pathol Pharmacol.* 1995;90:69–74.
- Kanetsuna Y, Takahashi K, Nagata M, Gannon MA, Breyer MD, Harris RC, Takahashi T. Deficiency of endothelial nitric-oxide synthase confers susceptibility to diabetic nephropathy in nephropathy-resistant inbred mice. *Am J Pathol.* 2007;170:1473–84.
- Keenan HA, Costacou T, Sun JK, Doria A, Cavallerano J, Coney J, Orchard TJ, Aiello LP, King GL. Clinical factors associated with resistance to microvascular complications in diabetic patients of extreme disease duration: the 50-year medalist study. *Diabetes Care.* 2007;30:1995–7.
- Keenan JD, Fan AZ, Klein R. Retinopathy in nondiabetic persons with the metabolic syndrome: findings from the Third National Health and Nutrition Examination Survey. *Am J Ophthalmol.* 2009;147:934–44. e931–932
- Khamaisi M, Katagiri S, Keenan H, Park K, Maeda Y, Li Q, Qi W, Thomou T, Eschuk D, Tellechea A, Veves A, Huang C, Orgill DP, Wagers A, King GL. PKCdelta inhibition normalizes the wound-healing capacity of diabetic human fibroblasts. *J Clin Invest.* 2016;126:837–53.
- Kim J, Rushovich EH, Thomas TP, Ueda T, Agranoff BW, Greene DA. Diminished specific activity of cytosolic protein kinase C in sciatic nerve of streptozotocin-induced diabetic rats and its correction by dietary myo-inositol. *Diabetes.* 1991;40:1545–54.
- Kim YK, Lee MS, Son SM, Kim IJ, Lee WS, Rhim BY, Hong KW, Kim CD. Vascular NADH oxidase is involved in impaired endothelium-dependent vasodilation in OLETF rats, a model of type 2 diabetes. *Diabetes.* 2002;51:522–7.
- Kim BJ, Lee JK, Schuchman EH, Jin HK, Bae JS. Synergistic vasculogenic effects of AMD3100 and stromal-cell-derived factor-1alpha in vasa nervorum of the sciatic nerve of mice with diabetic peripheral neuropathy. *Cell Tissue Res.* 2013;354:395–407.
- Kojima N, Saito M, Mori A, Sakamoto K, Nakahara T, Ishii K. Role of cyclooxygenase in vasodilation of retinal blood vessels induced by bradykinin in Brown Norway rats. *Vasc Pharmacol.* 2009;51:119–24.
- Kolte D, Bryant J, Holsworth D, Wang J, Akbari P, Gibson G, Shariat-Madar Z. Biochemical characterization of a novel high-affinity and specific plasma kallikrein inhibitor. *Br J Pharmacol.* 2011;162:1639–49.
- Konishi H, Tanaka M, Takemura Y, Matsuzaki H, Ono Y, Kikkawa U, Nishizuka Y. Activation of protein kinase C by tyrosine phosphorylation in response to H<sub>2</sub>O<sub>2</sub>. *Proc Natl Acad Sci U S A.* 1997;94:11233–7.
- Kowluru RA, Zhong Q. Beyond AREDS: is there a place for antioxidant therapy in the prevention/treatment of eye disease? *Invest Ophthalmol Vis Sci.* 2011;52:8665–71.
- Kuhr F, Lowry J, Zhang Y, Brovkovych V, Skidgel RA. Differential regulation of inducible and endothelial nitric oxide synthase by kinin B1 and B2 receptors. *Neuropeptides.* 2010;44:145–54.
- Lassegue B, San Martin A, Griendling KK. Biochemistry, physiology, and pathophysiology of NADPH oxidases in the cardiovascular system. *Circ Res.* 2012;110:1364–90.

- Laursen JB, Somers M, Kurz S, McCann L, Warnholtz A, Freeman BA, Tarpey M, Fukai T, Harrison DG. Endothelial regulation of vasomotion in apoE-deficient mice: implications for interactions between peroxynitrite and tetrahydrobiopterin. *Circulation*. 2001;103:1282–8.
- Lawson SR, Gabra BH, Nantel F, Battistini B, Sirois P. Effects of a selective bradykinin B1 receptor antagonist on increased plasma extravasation in streptozotocin-induced diabetic rats: distinct vasculopathic profile of major key organs. *Eur J Pharmacol*. 2005;514:69–78.
- Lei H, Rheume MA, Kazlauskas A. Recent developments in our understanding of how platelet-derived growth factor (PDGF) and its receptors contribute to proliferative vitreoretinopathy. *Exp Eye Res*. 2010;90:376–81.
- Li Calzi S, Neu MB, Shaw LC, Grant MB. Endothelial progenitor dysfunction in the pathogenesis of diabetic retinopathy: treatment concept to correct diabetes-associated deficits. *EPMA J*. 2010;1:88–100.
- Li G, Tang J, Du Y, Lee CA, Kern TS. Beneficial effects of a novel RAGE inhibitor on early diabetic retinopathy and tactile allodynia. *Mol Vis*. 2011;17:3156–65.
- Lightman S. Does aldose reductase have a role in the development of the ocular complications of diabetes? *Eye (Lond)*. 1993;7(Pt 2):238–41.
- Lindahl P, Johansson BR, Leveen P, Betsholtz C. Pericyte loss and microaneurysm formation in PDGF-B-deficient mice. *Science*. 1997;277:242–5.
- Liu H, Luo Y, Zhang T, Zhang Y, Wu Q, Yuan L, Chung SS, Oates PJ, Yang JY. Genetic deficiency of aldose reductase counteracts the development of diabetic nephropathy in C57BL/6 mice. *Diabetologia*. 2011;54:1242–51.
- Lonn E, Yusuf S, Hoogwerf B, Pogue J, Yi Q, Zinman B, Bosch J, Dagenais G, Mann JF, Gerstein HC. Effects of vitamin E on cardiovascular and microvascular outcomes in high-risk patients with diabetes: results of the HOPE study and MICRO-HOPE substudy. *Diabetes Care*. 2002;25:1919–27.
- Loomans CJ, de Koning EJ, Staal FJ, Rookmaaker MB, Verseyden C, de Boer HC, Verhaar MC, Braam B, Rabelink TJ, van Zonneveld AJ. Endothelial progenitor cell dysfunction: a novel concept in the pathogenesis of vascular complications of type 1 diabetes. *Diabetes*. 2004;53:195–9.
- Ma RC, Tam CH, Wang Y, Luk AO, Hu C, Yang X, Lam V, Chan AW, Ho JS, Chow CC, Tong PC, Jia W, Ng MC, So WY, Chan JC. Genetic variants of the protein kinase C-beta 1 gene and development of end-stage renal disease in patients with type 2 diabetes. *JAMA*. 2010;304:881–9.
- Maeno Y, Li Q, Park K, Rask-Madsen C, Gao B, Matsumoto M, Liu Y, Wu IH, White MF, Feener EP, King GL. Inhibition of insulin signaling in endothelial cells by protein kinase C-induced phosphorylation of p85 subunit of phosphatidylinositol 3-kinase (PI3K). *J Biol Chem*. 2012;287:4518–30.
- Marceau F, Regoli D. Bradykinin receptor ligands: therapeutic perspectives. *Nat Rev Drug Discov*. 2004;3:845–52.
- Mark AB, Poulsen MW, Andersen S, Andersen JM, Bak MJ, Ritz C, Holst JJ, Nielsen J, de Courten B, Dragsted LO, Bugel SG. Consumption of a diet low in advanced glycation end products for 4 weeks improves insulin sensitivity in overweight women. *Diabetes Care*. 2014;37:88–95.
- Matsumoto T, Kobayashi T, Kamata K. Relationships among ET-1, PPARgamma, oxidative stress and endothelial dysfunction in diabetic animals. *J Smooth Muscle Res*. 2008;44:41–55.
- Mauer M, Zinman B, Gardiner R, Suissa S, Sinaiko A, Strand T, Drummond K, Donnelly S, Goodyer P, Gubler MC, Klein R. Renal and retinal effects of enalapril and losartan in type 1 diabetes. *N Engl J Med*. 2009;361:40–51.
- Meier M, Menne J, Park JK, Holtz M, Gueler F, Kirsch T, Schiffer M, Mengel M, Lindschau C, Leites M, Haller H. Deletion of protein kinase C-epsilon signaling pathway induces glomerulosclerosis and tubulointerstitial fibrosis in vivo. *J Am Soc Nephrol*. 2007;18:1190–8.
- Menne J, Park JK, Boehne M, Elger M, Lindschau C, Kirsch T, Meier M, Gueler F, Fiebeler A, Bahlmann FH, Leites M, Haller H. Diminished loss of proteoglycans and lack of albuminuria in protein kinase C-alpha-deficient diabetic mice. *Diabetes*. 2004;53:2101–9.

- Mima A, Kitada M, Geraldine P, Li Q, Matsumoto M, Mizutani K, Qi W, Li C, Leitges M, Rask-Madsen C, King GL. Glomerular VEGF resistance induced by PKCdelta/SHP-1 activation and contribution to diabetic nephropathy. *FASEB J*. 2012;26:2963–74.
- Minamino T, Miyauchi H, Yoshida T, Ishida Y, Yoshida H, Komuro I. Endothelial cell senescence in human atherosclerosis: role of telomere in endothelial dysfunction. *Circulation*. 2002;105:1541–4.
- Molitch ME, DeFronzo RA, Franz MJ, Keane WF, Mogensen CE, Parving HH, Steffes MW. Nephropathy in diabetes. *Diabetes Care*. 2004;27(Suppl 1):S79–83.
- Motawi TK, Rizk SM, Ibrahim IA, El-Emady YF. Alterations in circulating angiogenic and anti-angiogenic factors in type 2 diabetic patients with neuropathy. *Cell Biochem Funct*. 2014;32:155–63.
- Murakami T, Frey T, Lin C, Antonetti DA. Protein kinase cbeta phosphorylates occludin regulating tight junction trafficking in vascular endothelial growth factor-induced permeability in vivo. *Diabetes*. 2012;61:1573–83.
- Nakagawa T, Sato W, Glushakova O, Heinig M, Clarke T, Campbell-Thompson M, Yuzawa Y, Atkinson MA, Johnson RJ, Croker B. Diabetic endothelial nitric oxide synthase knockout mice develop advanced diabetic nephropathy. *J Am Soc Nephrol*. 2007;18:539–50.
- Nakamura J, Kato K, Hamada Y, Nakayama M, Chaya S, Nakashima E, Naruse K, Kasuya Y, Mizubayashi R, Miwa K, Yasuda Y, Kamiya H, Ienaga K, Sakakibara F, Koh N, Hotta N. A protein kinase C-beta-selective inhibitor ameliorates neural dysfunction in streptozotocin-induced diabetic rats. *Diabetes*. 1999;48:2090–5.
- Nakamura S, Chikaraishi Y, Tsuruma K, Shimazawa M, Hara H. Ruboxistaurin, a PKCbeta inhibitor, inhibits retinal neovascularization via suppression of phosphorylation of ERK1/2 and Akt. *Exp Eye Res*. 2010;90:137–45.
- Naruse K, Rask-Madsen C, Takahara N, Ha SW, Suzuma K, Way KJ, Jacobs JR, Clermont AC, Ueki K, Ohshiro Y, Zhang J, Goldfine AB, King GL. Activation of vascular protein kinase C-beta inhibits Akt-dependent endothelial nitric oxide synthase function in obesity-associated insulin resistance. *Diabetes*. 2006;55:691–8.
- Neuenschwander H, Takahashi Y, Kador PF. Dose-dependent reduction of retinal vessel changes associated with diabetic retinopathy in galactose-fed dogs by the aldose reductase inhibitor M79175. *J Ocul Pharmacol Ther*. 1997;13:517–28.
- Newton AC. Regulation of the ABC kinases by phosphorylation: protein kinase C as a paradigm. *Biochem J*. 2003;370:361–71.
- Nishikawa T, Edelstein D, Du XL, Yamagishi S, Matsumura T, Kaneda Y, Yorek MA, Beebe D, Oates PJ, Hammes HP, Giardino I, Brownlee M. Normalizing mitochondrial superoxide production blocks three pathways of hyperglycaemic damage. *Nature*. 2000;404:787–90.
- Ohshiro Y, Ma RC, Yasuda Y, Hiraoka-Yamamoto J, Clermont AC, Isshiki K, Yagi K, Arikawa E, Kern TS, King GL. Reduction of diabetes-induced oxidative stress, fibrotic cytokine expression, and renal dysfunction in protein kinase Cbeta-null mice. *Diabetes*. 2006;55:3112–20.
- Oliver FJ, de la Rubia G, Feener EP, Lee ME, Loeken MR, Shiba T, Quertermous T, King GL. Stimulation of endothelin-1 gene expression by insulin in endothelial cells. *J Biol Chem*. 1991;266:23251–6.
- Orsenigo F, Giampietro C, Ferrari A, Corada M, Galaup A, Sigismund S, Ristagno G, Maddaluno L, Koh GY, Franco D, Kurtcuoglu V, Poulidakos D, Baluk P, McDonald D, Grazia Lampugnani M, Dejana E. Phosphorylation of VE-cadherin is modulated by haemodynamic forces and contributes to the regulation of vascular permeability in vivo. *Nat Commun*. 2012;3:1208.
- Othman A, Ahmad S, Megyerdi S, Mussell R, Choksi K, Maddipati KR, Elmarakby A, Rizk N, Al-Shabraway M. 12/15-Lipoxygenase-derived lipid metabolites induce retinal endothelial cell barrier dysfunction: contribution of NADPH oxidase. *PLoS One*. 2013;8:e57254.
- Park L, Raman KG, Lee KJ, Lu Y, Ferran LJ Jr, Chow WS, Stern D, Schmidt AM. Suppression of accelerated diabetic atherosclerosis by the soluble receptor for advanced glycation endproducts. *Nat Med*. 1998;4:1025–31.

- Park K, Li Q, Rask-Madsen C, Mima A, Mizutani K, Winnay J, Maeda Y, D'Aquino K, White MF, Feener EP, King GL. Serine phosphorylation sites on IRS2 activated by angiotensin II and protein kinase C to induce selective insulin resistance in endothelial cells. *Mol Cell Biol.* 2013;33:3227–41.
- Park K, Mima A, Li Q, Rask-Madsen C, He P, Mizutani K, Katagiri S, Maeda Y, Wu IH, Khamaisi M, Preil SR, Maddaloni E, Sorensen D, Rasmussen LM, Huang PL, King GL. Insulin decreases atherosclerosis by inducing endothelin receptor B expression. *JCI Insight.* 2016;1:e86574.
- Parmer TG, Ward MD, Hait WN. Effects of rottlerin, an inhibitor of calmodulin-dependent protein kinase III, on cellular proliferation, viability, and cell cycle distribution in malignant glioma cells. *Cell Growth Differ.* 1997;8:327–34.
- Patel A, MacMahon S, Chalmers J, Neal B, Billot L, Woodward M, Marre M, Cooper M, Glasziou P, Grobbee D, Hamet P, Harrap S, Heller S, Liu L, Mancia G, Mogensen CE, Pan C, Poulter N, Rodgers A, Williams B, Bompoint S, de Galan BE, Joshi R, Travert F. Intensive blood glucose control and vascular outcomes in patients with type 2 diabetes. *N Engl J Med.* 2008;358:2560–72.
- Perkins BA, Ficociello LH, Silva KH, Finkelstein DM, Warram JH, Krolewski AS. Regression of microalbuminuria in type 1 diabetes. *N Engl J Med.* 2003;348:2285–93.
- Petersen M, Thorikay M, Deckers M, van Dinther M, Grygielko ET, Gellibert F, de Gouville AC, Huet S, ten Dijke P, Laping NJ. Oral administration of GW788388, an inhibitor of TGF-beta type I and II receptor kinases, decreases renal fibrosis. *Kidney Int.* 2008;73:705–15.
- Phipps JA, Clermont AC, Sinha S, Chilcote TJ, Bursell SE, Feener EP. Plasma kallikrein mediates angiotensin II type 1 receptor-stimulated retinal vascular permeability. *Hypertension.* 2009;53:175–81.
- Plesnila N, Schulz J, Stoffel M, Eriskat J, Pruneau D, Baethmann A. Role of bradykinin B2 receptors in the formation of vasogenic brain edema in rats. *J Neurotrauma.* 2001;18:1049–58.
- Pouliot M, Talbot S, Senecal J, Dotigny F, Vaucher E, Couture R. Ocular application of the kinin B1 receptor antagonist LF22-0542 inhibits retinal inflammation and oxidative stress in streptozotocin-diabetic rats. *PLoS One.* 2012;7:e33864.
- Pruneau D, Belichard P, Sahel JA, Combal JP. Targeting the kallikrein-kinin system as a new therapeutic approach to diabetic retinopathy. *Curr Opin Investig Drugs.* 2010;11:507–14.
- Ramasamy R, Goldberg IJ. Aldose reductase and cardiovascular diseases, creating human-like diabetic complications in an experimental model. *Circ Res.* 2010;106:1449–58.
- Ramasamy R, Yan SF, Schmidt AM. RAGE: therapeutic target and biomarker of the inflammatory response – the evidence mounts. *J Leukoc Biol.* 2009;86:505–12.
- Rask-Madsen C, King GL. Vascular complications of diabetes: mechanisms of injury and protective factors. *Cell Metab.* 2013;17:20–33.
- Rask-Madsen C, Li Q, Freund B, Feather D, Abramov R, Wu IH, Chen K, Yamamoto-Hiraoka J, Goldenbogen J, Sotiropoulos KB, Clermont A, Geraldine P, Dall'Osso C, Wagers AJ, Huang PL, Reikter M, Scalia R, Kahn CR, King GL. Loss of insulin signaling in vascular endothelial cells accelerates atherosclerosis in apolipoprotein E null mice. *Cell Metab.* 2010;11:379–89.
- Reddy VP, Obrenovich ME, Atwood CS, Perry G, Smith MA. Involvement of Maillard reactions in Alzheimer disease. *Neurotox Res.* 2002;4:191–209.
- Ruiz S, Pergola PE, Zager RA, Vaziri ND. Targeting the transcription factor Nrf2 to ameliorate oxidative stress and inflammation in chronic kidney disease. *Kidney Int.* 2013;83:1029–41.
- Ruscetti F, Varesio L, Ochoa A, Ortaldo J. Pleiotropic effects of transforming growth factor-beta on cells of the immune system. *Ann N Y Acad Sci.* 1993;685:488–500.
- Sainz IM, Pixley RA, Colman RW. Fifty years of research on the plasma kallikrein-kinin system: from protein structure and function to cell biology and in-vivo pathophysiology. *Thromb Haemost.* 2007;98:77–83.
- Sakaguchi T, Yan SF, Yan SD, Belov D, Rong LL, Sousa M, Andrassy M, Marso SP, Duda S, Arnold B, Liliensiek B, Nawroth PP, Stern DM, Schmidt AM, Naka Y. Central role of RAGE-dependent neointimal expansion in arterial restenosis. *J Clin Invest.* 2003;111:959–72.

- Schmidt AM, Hori O, Brett J, Yan SD, Wautier JL, Stern D. Cellular receptors for advanced glycation end products. Implications for induction of oxidant stress and cellular dysfunction in the pathogenesis of vascular lesions. *Arterioscler Thromb*. 1994;14:1521–8.
- Sheetz MJ, Aiello LP, Davis MD, Danis R, Bek T, Cunha-Vaz J, Shahri N, Berg PH. The effect of the oral PKC beta inhibitor ruboxistaurin on vision loss in two phase 3 studies. *Invest Ophthalmol Vis Sci*. 2013;54:1750–7.
- Shiba T, Inoguchi T, Sportsman JR, Heath WF, Bursell S, King GL. Correlation of diacylglycerol level and protein kinase C activity in rat retina to retinal circulation. *Am J Phys*. 1993;265:E783–93.
- Sivaskandarajah GA, Jeansson M, Maezawa Y, Eremina V, Baelde HJ, Quaggin SE. Vegfa protects the glomerular microvasculature in diabetes. *Diabetes*. 2012;61:2958–66.
- Sogawa K, Nagaoka T, Izumi N, Nakabayashi S, Yoshida A. Acute hyperglycemia-induced endothelial dysfunction in retinal arterioles in cats. *Invest Ophthalmol Vis Sci*. 2010;51:2648–55.
- Soltoff SP. Rottlerin: an inappropriate and ineffective inhibitor of PKCdelta. *Trends Pharmacol Sci*. 2007;28:453–8.
- Srivastava SK, Hair GA, Das B. Activated and unactivated forms of human erythrocyte aldose reductase. *Proc Natl Acad Sci U S A*. 1985;82:7222–6.
- Stevens MJ, Dananberg J, Feldman EL, Lattimer SA, Kamijo M, Thomas TP, Shindo H, Sima AA, Greene DA. The linked roles of nitric oxide, aldose reductase and, (Na<sup>+</sup>,K<sup>+</sup>)-ATPase in the slowing of nerve conduction in the streptozotocin diabetic rat. *J Clin Invest*. 1994;94:853–9.
- Sun JK, Keenan HA, Cavallerano JD, Asztalos BF, Schaefer EJ, Sell DR, Strauch CM, Monnier VM, Doria A, Aiello LP, King GL. Protection from retinopathy and other complications in patients with type 1 diabetes of extreme duration: the joslin 50-year medalist study. *Diabetes Care*. 2011;34:968–74.
- Suzuma K, Takahara N, Suzuma I, Isshiki K, Ueki K, Leitges M, Aiello LP, King GL. Characterization of protein kinase C beta isoform's action on retinoblastoma protein phosphorylation, vascular endothelial growth factor-induced endothelial cell proliferation, and retinal neovascularization. *Proc Natl Acad Sci U S A*. 2002;99:721–6.
- Sytze Van Dam P, Cotter MA, Bravenboer B, Cameron NE. Pathogenesis of diabetic neuropathy: focus on neurovascular mechanisms. *Eur J Pharmacol*. 2013;719:180–6.
- Tanaka S, Yoshimura Y, Kawasaki R, Kamada C, Horikawa C, Ohashi Y, Araki A, Ito H, Akanuma Y, Yamada N, Yamashita H, Sone H. Fruit intake and incident diabetic retinopathy with type 2 diabetes. *Epidemiology*. 2013;24:204–11.
- Taniguchi K, Xia L, Goldberg HJ, Lee KW, Shah A, Stavar L, Masson EA, Momen A, Shikatani EA, John R, Husain M, Fantus IG. Inhibition of Src kinase blocks high glucose-induced EGFR transactivation and collagen synthesis in mesangial cells and prevents diabetic nephropathy in mice. *Diabetes*. 2013;62:3874–86.
- Tebay LE, Robertson H, Durant ST, Vitale SR, Penning TM, Dinkova-Kostova AT, Hayes JD. Mechanisms of activation of the transcription factor Nrf2 by redox stressors, nutrient cues, and energy status and the pathways through which it attenuates degenerative disease. *Free Radic Biol Med*. 2015;88:108–46.
- Thallas-Bonke V, Thorpe SR, Coughlan MT, Fukami K, Yap FY, Sourris KC, Penfold SA, Bach LA, Cooper ME, Forbes JM. Inhibition of NADPH oxidase prevents advanced glycation end product-mediated damage in diabetic nephropathy through a protein kinase C- $\alpha$ -dependent pathway. *Diabetes*. 2008;57:460–9.
- The Diabetes Control and Complications Trial Research Group. The effect of intensive treatment of diabetes on the development and progression of long-term complications in insulin-dependent diabetes mellitus. *N Engl J Med*. 1993;329:977–86.
- The Diabetes Control and Complications Trial/Epidemiology of Diabetes Interventions and Complications Research Group. Retinopathy and nephropathy in patients with type 1 diabetes four years after a trial of intensive therapy. *N Engl J Med*. 2000;342:381–9.

- The PKC-DRS Study Group. The effect of ruboxistaurin on visual loss in patients with moderately severe to very severe nonproliferative diabetic retinopathy: initial results of the Protein Kinase C beta Inhibitor Diabetic Retinopathy Study (PKC-DRS) multicenter randomized clinical trial. *Diabetes*. 2005;54:2188–97.
- Thum T, Fraccarollo D, Schultheiss M, Froese S, Galuppo P, Widder JD, Tsikas D, Ertl G, Bauersachs J. Endothelial nitric oxide synthase uncoupling impairs endothelial progenitor cell mobilization and function in diabetes. *Diabetes*. 2007;56:666–74.
- Trueblood N, Ramasamy R. Aldose reductase inhibition improves altered glucose metabolism of isolated diabetic rat hearts. *Am J Phys*. 1998;275:H75–83.
- Tsuchiya K, Tanaka J, Shuiqing Y, Welch CL, DePinho RA, Tabas I, Tall AR, Goldberg IJ, Accili D. FoxOs integrate pleiotropic actions of insulin in vascular endothelium to protect mice from atherosclerosis. *Cell Metab*. 2012;15:372–81.
- Tuttle KR, Anderson PW. A novel potential therapy for diabetic nephropathy and vascular complications: protein kinase C beta inhibition. *Am J Kidney Dis*. 2003;42:456–65.
- Tuttle KR, Bakris GL, Toto RD, McGill JB, Hu K, Anderson PW. The effect of ruboxistaurin on nephropathy in type 2 diabetes. *Diabetes Care*. 2005;28:2686–90.
- Tutuncu NB, Bayraktar M, Varli K. Reversal of defective nerve conduction with vitamin E supplementation in type 2 diabetes: a preliminary study. *Diabetes Care*. 1998;21:1915–8.
- Uzar E, Tamam Y, Evliyaoglu O, Tuzcu A, Beyaz C, Acar A, Aydin B, Tasdemir N. Serum prolidase activity and oxidative status in patients with diabetic neuropathy. *Neurol Sci*. 2012;33:875–80.
- Veron D, Bertuccio CA, Marlier A, Reidy K, Garcia AM, Jimenez J, Velazquez H, Kashgarian M, Moeckel GW, Tufro A. Podocyte vascular endothelial growth factor (Vegf1)(6)(4) over-expression causes severe nodular glomerulosclerosis in a mouse model of type 1 diabetes. *Diabetologia*. 2011;54:1227–41.
- Vinik AI, Bril V, Kempner P, Litchy WJ, Tesfaye S, Price KL, Bastyr EJ 3rd. Treatment of symptomatic diabetic peripheral neuropathy with the protein kinase C beta-inhibitor ruboxistaurin mesylate during a 1-year, randomized, placebo-controlled, double-blind clinical trial. *Clin Ther*. 2005;27:1164–80.
- Voelker J, Berg PH, Sheetz M, Duffin K, Shen T, Moser B, Greene T, Blumenthal SS, Rychlik I, Yagil Y, Zaoui P, Lewis JB. Anti-TGF-beta1 antibody therapy in patients with diabetic nephropathy. *J Am Soc Nephrol*. 2017;28(3):953–62.
- Wang H, Wang AX, Liu Z, Chai W, Barrett EJ. The trafficking/interaction of eNOS and caveolin-1 induced by insulin modulates endothelial nitric oxide production. *Mol Endocrinol*. 2009;23:1613–23.
- Wang N, Zheng Z, Jin HY, Xu X. Treatment effects of captopril on non-proliferative diabetic retinopathy. *Chin Med J*. 2012;125:287–92.
- Wei Y, Gong J, Yoshida T, Eberhart CG, Xu Z, Kombairaju P, Sporn MB, Handa JT, Duh EJ. Nrf2 has a protective role against neuronal and capillary degeneration in retinal ischemia-reperfusion injury. *Free Radic Biol Med*. 2011;51:216–24.
- Welsh GI, Hale LJ, Eremina V, Jeansson M, Maezawa Y, Lennon R, Pons DA, Owen RJ, Satchell SC, Miles MJ, Caunt CJ, McArdle CA, Pavenstadt H, Tavare JM, Herzenberg AM, Kahn CR, Mathieson PW, Quaggin SE, Saleem MA, Coward RJ. Insulin signaling to the glomerular podocyte is critical for normal kidney function. *Cell Metab*. 2010;12:329–40.
- Wilkinson-Berka JL, Tan G, Binger KJ, Sutton L, McMaster K, Deliyanti D, Perera G, Campbell DJ, Miller AG. Aliskiren reduces vascular pathology in diabetic retinopathy and oxygen-induced retinopathy in the transgenic (mRen-2)27 rat. *Diabetologia*. 2011;54:2724–35.
- Wu XH, Chen X, Zhang SL, Pang L, To C, Wang TT, Hohman TC, Filep JG, Chan JS. Molecular mechanism(s) of insulin action on the expression of the angiotensinogen gene in kidney proximal tubular cells. *J Renin-Angiotensin-Aldosterone Syst*. 2000;1:166–74.
- Wu YB, Li HQ, Ren MS, Li WT, Lv XY, Wang L. CHOP/ORP150 ratio in endoplasmic reticulum stress: a new mechanism for diabetic peripheral neuropathy. *Cell Physiol Biochem*. 2013;32:367–79.

- Xia P, Inoguchi T, Kern TS, Engerman RL, Oates PJ, King GL. Characterization of the mechanism for the chronic activation of diacylglycerol-protein kinase C pathway in diabetes and hypergalactosemia. *Diabetes*. 1994;43:1122–9.
- Yamagishi S, Uehara K, Otsuki S, Yagihashi S. Differential influence of increased polyol pathway on protein kinase C expressions between endoneurial and epineurial tissues in diabetic mice. *J Neurochem*. 2003;87:497–507.
- Yamamoto Y, Kato I, Doi T, Yonekura H, Ohashi S, Takeuchi M, Watanabe T, Yamagishi S, Sakurai S, Takasawa S, Okamoto H, Yamamoto H. Development and prevention of advanced diabetic nephropathy in RAGE-overexpressing mice. *J Clin Invest*. 2001;108:261–8.
- Yan J, Tie G, Park B, Yan Y, Nowicki PT, Messina LM. Recovery from hind limb ischemia is less effective in type 2 than in type 1 diabetic mice: roles of endothelial nitric oxide synthase and endothelial progenitor cells. *J Vasc Surg*. 2009;50:1412–22.
- Yan SF, Ramasamy R, Schmidt AM. Soluble RAGE: therapy and biomarker in unraveling the RAGE axis in chronic disease and aging. *Biochem Pharmacol*. 2010;79:1379–86.
- Yayama K, Okamoto H. Angiotensin II-induced vasodilation via type 2 receptor: role of bradykinin and nitric oxide. *Int Immunopharmacol*. 2008;8:312–8.
- Yeung CM, Lo AC, Cheung AK, Chung SS, Wong D, Chung SK. More severe type 2 diabetes-associated ischemic stroke injury is alleviated in aldose reductase-deficient mice. *J Neurosci Res*. 2010;88:2026–34.
- Yi X, Schubert M, Peachey NS, Suzuma K, Burks DJ, Kushner JA, Suzuma I, Cahill C, Flint CL, Dow MA, Leshan RL, King GL, White MF. Insulin receptor substrate 2 is essential for maturation and survival of photoreceptor cells. *J Neurosci*. 2005;25:1240–8.
- Yokota T, Ma RC, Park JY, Isshiki K, Sotiropoulos KB, Rauniyar RK, Bornfeldt KE, King GL. Role of protein kinase C on the expression of platelet-derived growth factor and endothelin-1 in the retina of diabetic rats and cultured retinal capillary pericytes. *Diabetes*. 2003;52:838–45.
- You YH, Okada S, Ly S, Jandeleit-Dahm K, Barit D, Namikoshi T, Sharma K. Role of Nox2 in diabetic kidney disease. *Am J Physiol Ren Physiol*. 2013;304:F840–8.
- Zhang H, Davies KJ, Forman HJ. Oxidative stress response and Nrf2 signaling in aging. *Free Radic Biol Med*. 2015;88:314–36.
- Zhao HJ, Wang S, Cheng H, Zhang MZ, Takahashi T, Fogo AB, Breyer MD, Harris RC. Endothelial nitric oxide synthase deficiency produces accelerated nephropathy in diabetic mice. *J Am Soc Nephrol*. 2006;17:2664–9.
- Zhong Q, Mishra M, Kowluru RA. Transcription factor Nrf2-mediated antioxidant defense system in the development of diabetic retinopathy. *Invest Ophthalmol Vis Sci*. 2013;54:3941–8.
- Ziyadeh FN, Hoffman BB, Han DC, Iglesias-De La Cruz MC, Hong SW, Isono M, Chen S, McGowan TA, Sharma K. Long-term prevention of renal insufficiency, excess matrix gene expression, and glomerular mesangial matrix expansion by treatment with monoclonal anti-transforming growth factor-beta antibody in db/db diabetic mice. *Proc Natl Acad Sci U S A*. 2000;97:8015–20.
- Zou Y, Komuro I, Yamazaki T, Kudoh S, Aikawa R, Zhu W, Shiojima I, Hiroi Y, Tobe K, Kadowaki T, Yazaki Y. Cell type-specific angiotensin II-evoked signal transduction pathways: critical roles of Gbetagamma subunit, Src family, and Ras in cardiac fibroblasts. *Circ Res*. 1998;82:337–45.



# Diabetes and the Kidney

# 7

Anna Solini and Pietro Castellino

## Contents

Epidemiology .....	204
Clinical Presentation .....	205
Natural History of Diabetic Kidney Disease: The Classical View .....	205
Stage I .....	205
Stage II .....	207
Stage III .....	207
Stage IV .....	208
Stage V .....	209
Additional Renal Complications .....	212
Management of the Renal Damage in Diabetes .....	213
The Role of the Glucose Control .....	213
Insulin Treatment .....	217
Glomerular Hemodynamic and Blood Pressure Control .....	219
Diabetic Nephropathy and Cardiovascular Disease .....	223
Epidemiology .....	223
Mechanisms of Macrovascular Damage in Patients with Diabetes and CKD .....	224
References .....	226

## Abstract

Diabetic renal disease represents the first cause of chronic renal disease in industrialized countries. The incidence in developing countries is also increasing. The natural history of renal disease in diabetes was first described in type 1

---

A. Solini (✉)

Department of Surgical, Medical, Molecular and Critical Area Pathology, University of Pisa, Pisa, Italy

e-mail: [anna.solini@med.unipi.it](mailto:anna.solini@med.unipi.it)

P. Castellino

Department of Clinical and Experimental Medicine, University of Catania, Catania, Italy

e-mail: [pcastell@unict.it](mailto:pcastell@unict.it)



patients and is characterized by proteinuria and a declining GFR. Retinal disease is also present. In recent years, the natural history of the disease has changed with a high incidence of nonproteinuric and nonprogressing courses of the disease. In recent years, new therapeutic agents have been introduced with very promising clinical outcome both for renal disease progression and cardiovascular outcome.

---

**Keywords**

Albuminuria-centric model · Aliskiren · Arteriosclerosis · Atherosclerosis · Chronic kidney disease (CKD) · Diabetic kidney disease · Enalapril · Glomerular filtration rate (GFR) · Glycosuria · Hyperglycemia · Incretins · Metformin · Microalbuminuria · Non-albuminuric renal impairment · Olmesartan · Proteinuria · Ramipril · Renal disease · Renin-angiotensin system (RAS) · Retinopathy · SGLT inhibitors · Thiazolidinediones (TDZs) · Trandolapril

---

**Epidemiology**

The global burden of chronic renal disease is steadily increasing worldwide. In Europe, in the USA, and in other industrialized countries, diabetes mellitus represents the first cause of end-stage renal insufficiency (Kidney Disease Outcomes Quality Initiative 2007; Kidney Disease Improving Global Outcomes 2013). In the USA, more than 40% of the incident patients undergoing renal replacement therapy either have diabetic nephropathy (DN) or have diabetes as a major comorbid condition. Prevalence of diabetes among US dialysis population is over 30%. In the USA, the absolute number of diabetic patients receiving care for end-stage renal disease, either dialysis or transplant, exceeds 200,000 individuals. Data derived from European countries also show a very high incidence rate and prevalence of diabetic kidney diseases. This trend is more evident in central and northern Europe than in the Mediterranean region. In Austria, the country with one of the most complete databases, prevalence rate is 22.8, 1.97, and 0.74 for CKD stages 3, 4, and 5, respectively (Kainz et al. 2015). The Renal Insufficiency and Cardiovascular Events (RIACE) Italian Multicenter Study in a cohort of 15,773 type 2 diabetics reported a prevalence of 17.1% and 1.6% for CKD stages 3 and 4–5, respectively (Penno et al. 2011). Thus, if the chances of developing end-stage renal disease are elevated, the overall risk of renal disease in diabetics is by far greater, with approximately 25% of all diabetic patients showing some degree of renal dysfunction or failure. Ethnicity also plays a role in the natural history of diabetic nephropathy. In the USA, the relative risk of developing renal disease is sixfold higher in Caucasian diabetics vs. nondiabetics, but it increases even further in other ethnic groups as Blacks, Hispanics, and Orientals, with the higher relative risk found in Native Americans. In these ethnic groups, in addition to a genetic predisposition, various socioeconomic factors as well as access to treatment and compliance have been shown to play a role in the development of renal disease (De Boer et al. 2011). At variance with macrovascular complications, the incidence rate of kidney disease in the diabetic population is not declining. As a result, the prevalence of diabetic nephropathy (DN) is increasing, with an epidemiology that closely parallels the rising prevalence of diabetes and obesity both in industrialized and developing

countries. In the USA, the prevalence of diabetic kidney disease has risen in the general population from 2.2% in NHANES III to 2.8% and 3.2% in NHANES 1999–2004 and 2004–2009, respectively (De Boer et al. 2011). Up to the year 2025, the prevalence in Europe is also estimated to rise (Kainz et al. 2015). In the last decades, the incidence rate of DN was higher in patients with type 1 diabetes (T1D), with more than 30% of patients eventually developing some degree of renal disease. In contrast, renal involvement was considered to be less frequent in type 2 diabetes (T2D). Thus, because of the higher prevalence of T2D in the general population, a similar absolute number of type 1 and type 2 patients needed chronic renal replacement therapy. More recent data derived by long-term follow-up of large cohorts have shown that a similar percentage of T1D and T2D patients will eventually develop a renal impairment. Nephropathy becomes clinically evident late in the course of diabetes. It is conceivable that its prevalence is indirectly favored by the better care achieved for the more precocious onset of cardiovascular and metabolic complications of diabetes and the longer patients' survival. These findings are reflected in the data derived by several national registries and data systems showing that in recent years the vast majority of diabetic patients entering a dialysis or transplant program have type 2 diabetes. Dialysis or renal transplantation represents hard endpoints which are easy to pinpoint in any epidemiologic survey. In contrast, the prevalence and clinical features of less advanced forms of renal involvement are an open matter of debate. To this regard, if the prevalence of microalbuminuria and proteinuria is declining especially among younger patients, an increased prevalence of non-proteinuric impairment in glomerular filtration rate (GFR) is observed, and it may represent a novel clinical phenotype accounting for a large proportion of patients with diabetic kidney disease.

---

## Clinical Presentation

### Natural History of Diabetic Kidney Disease: The Classical View

The natural history of DN was originally described at the end of the last century (Mogensen 1999), and it encompasses five progressive stages. To a large extent, it is derived from studies in T1D. Although they represent only a minority of the entire diabetic population, nephropathy in type 1 patients was chosen as a model of the disease, because the clinical history of their renal involvement is more linear, the onset of diabetes is well defined, and type 1 patients are younger with a lower burden of additional and confounding clinical conditions (Papadopoulou-Marketou et al. 2016). The natural history is less clear in T2D in whom the onset of diabetes is not always well defined, and many confounding factors and comorbidities are present, often preceding the onset of diabetes itself.

### Stage I

Soon after the clinical onset of T1D, both renal plasma flow and GFR tend to increase. Their rise is proportional; thus no significant changes in filtration fraction

**Table 1** Formulae commonly used to estimate GFR

MDRD equation
<ul style="list-style-type: none"> <li>• GFR in mL/min per 1.73 m<sup>2</sup></li> <li>• <math>GFR = 186.3 \times (\text{serum creatinine in mg/dL})^{-1.154} \times \text{age}^{-0.203} \times (1.210 \text{ if black}) \times (0.742 \text{ if female})</math></li> </ul>
CKD-EPI equation
<ul style="list-style-type: none"> <li>• <math>GFR = 141 \times \text{minimum}(\text{Scr/K}, 1)^\alpha \times \text{maximum}(\text{Scr/K}, 1)^{-1.209} \times 0.993^{\text{Age}} \times (1.018 \text{ if female}) \times (1.159 \text{ if black})</math></li> <li>• Scr is serum creatinine, K is 0.7 for females and 0.9 for males, <math>\alpha</math> is <math>-0.329</math> for females and <math>-0.411</math> for males</li> <li>• <i>Minimum</i> indicates the minimum of Scr/K or 1; <i>maximum</i> indicates the maximum of Scr/K or 1</li> </ul>

are observed. Estimated GFR (eGFR) (usually by the formulae reported in Table 1) and measured creatinine clearance values rise up to 150–180 mL/min. This state of glomerular hyperfiltration can last for several years and is associated with a diffuse and global glomerular hypertrophy with an increase in the total volume of each glomerulus and an enlargement in the size of the capillary tuft. From a morphometric viewpoint, it has been suggested that DN is definitely a complex disease, where inflammation and tubular alterations might precede or at least accompany glomerular changes. Initial mesangial matrix expansion may be observed very early in the course of the disease (Fioretto et al. 1999). Diabetic tubulopathy is characterized by a variety of structural and functional alterations including tubule-epithelial cell hypertrophy, tubular basement membrane thickening, epithelial-mesenchymal transition, and glycogen accumulation. Recent studies have indeed proposed that initial hyperfiltration is likely driven by impaired tubulo-glomerular feedback mechanisms, associated with hyperglycemia and diabetes-induced tubular dysfunction (Cherney et al. 2014).

The total volume of the kidney is increased, and the enlargement tends to persist up to the more advanced stages of renal disease. T2D patients also experience renal hyperfiltration and hypertrophy although these changes are less common and pronounced than in T1D patients. In obese and glucose-intolerant patients, glomerular hypertrophy and hyperfunction may well be present before the clinical diagnosis of diabetes is established. At this stage of the disease, urinary albumin excretion is normal. Occasionally, transient microalbuminuria or proteinuria may occur as they can be triggered by intercurrent illness, fever, stress, strenuous physical exercise, and poor metabolic control. Albuminuria may be reversed by the prompt correction of the precipitating factor. The clinical significance of these transient proteinuric episodes is still uncertain, but, if not corrected, it is conceivable that they may lead to an accelerated course of renal impairment (Papadopoulou-Marketou et al. 2016). Hypertension is usually absent in T1D patients at this early stage of the disease, but it is already present in at least 20–30% of T2D patients at their first clinical evaluation. The duration of this initial stage of the disease is at least 5–8 years. In more than 50% of patients, GFR will remain slightly elevated or normal for many years with enlarged kidneys and no sign of a clinical progression of the disease. Occasionally, diabetic patients may present with an abrupt onset of high range proteinuria and/or hematuria early in the course of the disease, with no previous evidences of albuminuria or

diabetic retinopathy. In these cases, DN is unlikely, and an alternative diagnosis should be seriously considered. At variance with the hyperfiltering phenotype, approximately 10% of type 1 and 30–50% T2D patients present with an early and sometime progressive decline in renal function with no evidence of micro- or overt albuminuria.

## Stage II

After a median of 8–10 years of diabetes, approximately 30% of type 1 patients will present with a urinary albumin excretion between 30 and 300 mg/24 h, originally named microalbuminuria (Mogensen 1999). Because of the difficulties in obtaining a complete and reliable 24-h urine collection, the ratio between albumin and creatinine excretion in spot urine or shorter collection can also be employed. A transient and reversible rise in urinary albumin excretion may occur; therefore, the true presence of albuminuria should be confirmed in repeated samples within a 6-month interval. Recent data, however, suggest that in T2D even a single determination of urinary albumin excretion provides a reliable estimate of renal involvement, with a confidence greater than 80%. At this stage of the disease, GFR remains either elevated or within the normal range. T1D individuals may develop hypertension which is typically absent in the non-albuminuric stage. More than 50% of T2D patients with microalbuminuria are hypertensive. Kidneys are enlarged, renal morphology is abnormal, and it shows diffuse glomerular enlargement with tubular basement membrane thickening, mesangial matrix expansion, and tubular changes. Approximately 20 years ago, it has been shown that, in kidney biopsies of microalbuminuric T2D individuals, typical glomerular lesions were evident in approximately 1/3 of cases, while 1/3 showed a combination of tubular and glomerular alterations, and the remaining 1/3, in face of the presence of microalbuminuria, showed no appreciable renal lesions. This and other similar observations suggested for the first time to regard albuminuria in T2D not only as a marker of renal impairment but, even better, as a marker of widespread vascular damage (Fioretto et al. 1999).

## Stage III

In the original descriptions of the clinical course of DN, the vast majority of microalbuminuric type 1 patients would eventually progress to overt albuminuria and proteinuria within 5–10 years (Mogensen 1999). Recent data, however, are more encouraging, and progression from micro- to overt albuminuria is estimated to occur in 10–40% of previously microalbuminuric patients, if an appropriate treatment is achieved and maintained (Perkins et al. 2003). At this stage of the disease, the GFR is lower when compared to age-matched controls, and the decline in GFR is even greater if compared to the previous hyperfiltering stages of the disease. With the progression of the disease, GFR will steadily decline. Patients are almost invariably hypertensive, plasma and extracellular volume are expanded, and blood pressure may become more difficult to control. If present, diabetic retinopathy

with hemorrhagic and proliferative patterns has been considered an indirect proof of the diabetic nature of the renal involvement; in recent years, however, this association has been questioned, especially in type 2 patients (Penno et al. 2011). Typical histological involvement at this stage of the disease is the Kimmelstiel-Wilson glomerular lesion either diffuse or nodular. An additional feature is a diffuse hyalinosis affecting both glomerular afferent and efferent arteries; this is at variance with the isolated afferent hyalinosis of essential hypertension. Tubular atrophy and interstitial fibrosis are also present. They are thought to play an important role in the clinical course of the disease, correlating with the decline in renal function. In T1D patients, renal histology confirms the diagnosis, but it does not provide an additional prognostic value; therefore if the clinical history is well documented and no alternative diagnosis can be put forward, routine renal biopsy is not indicated. In T2D patients, renal histology is less homogeneous, and many patients have mixed diabetic, hypertensive, and sclerotic lesions (Fioretto et al. 1996; Bertani et al. 1996). Ten to twenty percent of T2D patients with moderate or elevated proteinuria and reduced GFR have other glomerular diseases such as membranous glomerulopathy, focal segmental glomerulosclerosis, and light-chain or amyloid nephropathy, which may mimic many signs of diabetic kidney disease.

If not carefully treated, diabetic patients with stage III nephropathy will experience a negative course of the disease with hypertension, fluid retention, and edema and a progressive decline of GFR. At this stage of the disease, the cardiovascular risk and overall morbidity and mortality of both type 1 and 2 patients are significantly elevated.

## Stage IV

Patients typically show overt proteinuria; often in the nephrotic range, plasma creatinine is elevated, GFR is reduced, and the kidneys are inappropriately enlarged for the degree of renal insufficiency. Hypertension is invariably present and it may be resistant to medical treatment; plasma volume is expanded with edema. The clinical course is characterized by a relentless decline of renal function with a loss of GFR that usually ranges between 1 and 3 mL/month (Brenner et al. 2001; Lewis et al. 2001). Treatment of diabetes should be adapted to the decline in renal function, with the reduction of daily doses or the discontinuation of specific classes of drugs. The clearance of insulin is reduced, and doses should be tapered accordingly. Renal histology shows diffuse glomerular sclerosis and interstitial nephritis with fibrosis. In a significant proportion of cases, however, renal biopsy shows mixed diabetic and nondiabetic sclerotic lesions or signs of previous nondiabetic glomerular diseases. The overall and cardiovascular risk is elevated with the degree of proteinuria and the severity of hypertension negatively affecting both the general and the renal prognoses. Post hoc analysis of the RENAAL Study showed that after the onset of appropriate medical treatment, the decline in proteinuria predicts a more favorable course of the disease (Brenner et al. 2001). In recent years, a significant number of patients develop renal insufficiency without overt or nephrotic proteinuria; the

physiopathology and clinical significance of this condition are an open matter of debate (see below).

## Stage V

When GFR declines below 30 mL/min, a renal replacement therapy should be considered and initiated when GFR declines to 10 mL/min or less. In recent years the vast majority of patients reaching this advanced condition are type 2 diabetics. As previously discussed (see above) diabetics represent 30–40% of all patients who need a renal replacement therapy. The morbidity and mortality of diabetics with end-stage renal disease (ESRD) (stage V KDOQI) are elevated, with a 5-year survival of 20–25%. At this stage of the disease, many other diabetic complications are concomitantly present and contribute to the poor clinical outcome.

## Alternative Presentation of Diabetic Nephropathy

With respect to the above-described prototypical view, at least three concepts have been further questioned, i.e., (a) microalbuminuria necessarily evolves to macroalbuminuria, (b) GFR impairment follows the development of macroalbuminuria, and (c) the increase of albuminuria is paralleled by progression of retinopathy. In this new view of natural history of DN, several aspects are shared by T1D and T2D renal phenotypes (Tabaei et al. 2001).

### (a) *Microalbuminuria Does Not Always Precede Macroalbuminuria*

Microalbuminuria is generally considered as the earliest marker of the development of DN and is often associated with glomerular damage. However, recent studies showed that microalbuminuria may be temporary and does not necessarily reflect permanent renal impairment. In fact, diabetic glomerular lesions can be so advanced in microalbuminuric patients as to overlap with those detected in patients with overt proteinuria and reduced GFR. Besides, although earlier studies argued against the presence of significant diabetic glomerular changes in normoalbuminuric patients, these histopathological stigmata have been reported (Gall et al. 1997). As a matter of fact, glomerular lesions of DN can progress at varying rates within and between patients. For example, some patients may have relatively marked glomerular basement membrane thickening without much mesangial expansion and vice versa.

Moreover, several studies have shown that remission/regression of microalbuminuria is a quite common feature. In one study of renal structure and function in young T1D individuals, 64% of those who developed microalbuminuria reverted to normoalbuminuria (Perkins et al. 2003). In the Joslin Study of the Natural History of Microalbuminuria, a 58% 6-year cumulative incidence of regression was reported, defined as a 50% reduction in urinary albumin excretion rate from one 2-year period to the next; of the 220 subjects followed for 8 years, 45% remained microalbuminuric, 40% reverted to normoalbuminuria, and 15% progressed to proteinuria (Steinke et al. 2005).

Similar percentages were found in 352 microalbuminuric patients from the EURODIAB Prospective Complications Study (Giorgino et al. 2004).

The results of the Diabetes Control and Complications Trial (DCCT) highlighted the relationship between hyperglycemia and risk of DN (DCCT 1995). Intensive antidiabetic treatment may attenuate/reverse microalbuminuria, although it cannot be fully prevented, thus suggesting the intervention of additional factors determining its development and/or progression. A strong correlation between hypertension and glomerular structure derangement is largely demonstrated; thus, microalbuminuria and proteinuria risks are increased in patients with higher blood pressure levels. Remission/regression of microalbuminuria can be also attributed to the increasingly widespread use of blockers of the renin-angiotensin system (RAS), though some studies reported a loose correlation with these drugs (Perkins et al. 2003; Tabaei et al. 2001). Numerous potentially modifiable factors, some of them associated with a high cardiovascular risk profile, predict the development of incipient and overt DN in normoalbuminuric patients (Gall et al. 1997). Finally, the risk or progression of microalbuminuria and in general of DN is linked to genetic factors: for example, degrees and patterns of diabetic glomerular structural lesions are concordant among sibling pairs with T1D (Fioretto et al. 1999).

(b) *Microalbuminuria Does Not Always Precede the Decline in GFR*

In type 1 diabetes this paradigm has been challenged in the light of a newly described phenotype characterized by “early renal function decline.” As proposed by Perkins et al. (2003), the predominant clinical feature of both early and late stages of DN is progressive renal decline and not albuminuria, revealing that the “albuminuria-centric model” and its implications might be incorrect. Progressive renal decline, i.e., eGFR loss  $>3.5$  mL/min/year, is a unidirectional process that evolves while patients have normal renal function. It can be detected by using serial measurement of cystatin C and recognizes unique determinants. Progressive renal decline precedes the onset of microalbuminuria, and as it continues, it raises the risk of incidental proteinuria. Predictive factors are similar in non-proteinuric and microalbuminuric patients and include age, HbA1c, systolic blood pressure, uric acid, and inflammatory cytokines as tumor necrosis factor receptors (TNFR) 1 or 2.

In T2D, the Third National Health and Nutrition Examination Survey (NHANES III) reported that 36.1% of subjects with renal disease were normoalbuminuric and that neither albuminuria or retinopathy was present in 29.8% of diabetic patients with eGFR  $<60$  mL/min/1.73 m<sup>2</sup> (De Boer et al. 2011). Several studies have led to similar conclusions; among them, the Renal Insufficiency And Cardiovascular Event (RIACE) Study showed that a non-albuminuric renal impairment is the predominant clinical phenotype in T2D patients with reduced GFR and, again, that concordance between chronic kidney disease (CKD) and diabetic retinopathy is low (Penno et al. 2011). This variant of the natural history of DN in T2D is illustrated in Fig. 1.

Longitudinal analyses have defined more clearly the incidence, evolution, and risk factors of such non-albuminuric phenotype, which shares some

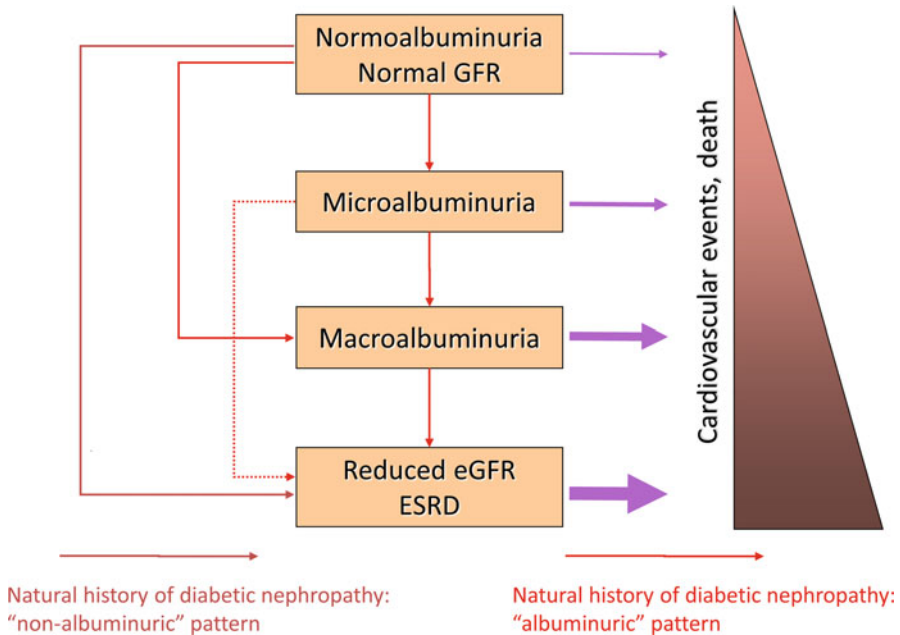

**Fig. 1** A proposed novel paradigm of the natural history of diabetic nephropathy in type 2 diabetes

characteristics with the “early decliner” in T1D. The UK Prospective Diabetes Study (UKPDS-74) investigated the incidence of reduced renal function, microalbuminuria, and macroalbuminuria in 4006 normoalbuminuric individuals with basal preserved GFR ( $>60$  mL/min per  $1.73$  m<sup>2</sup>). During 15 years of follow-up, 14% developed renal function impairment only, 24% microalbuminuria or macroalbuminuria only, and 14% developed both simultaneously (Retnakaran et al. 2006). As one could argue that most of these data rely on eGFR, studies with iohexol isotopic technique (i.e., the gold standard method for measuring GFR) have confirmed these results. Ruggenti and co-workers have found that, in a cohort of 600 patients with T2D, the median decrease of GFR is 3.37 mL/min/1.73 m<sup>2</sup> per year – a rate of renal function loss that was 2–5 times faster than noted in the general population – and that similar reduction degrees were observed in normoalbuminuric and microalbuminuric patients (Ruggenti et al. 2012).

Nevertheless, the relevance of macroalbuminuria and overt proteinuria as progression factors for GFR decline must not be diminished; indeed, in the STENO cohort, individuals with overt proteinuria had a mean yearly GFR decline of 5.2 mL/min/1.73 m<sup>2</sup>, and it became even faster, reaching 10.1 mL/min/1.73 m<sup>2</sup> in patients in the nephrotic stage participating in the REIN study. This aspect is reflected by a new classification in staging renal disease (Kidney Disease: Improving Global Outcomes, KDIGO) in which all categories are represented by both GFR and albuminuria instead of GFR alone, thus underlying the fact that reduced GFR may not be accompanied with albuminuria and that, if



present, predicts worse renal and cardiovascular outcomes (Kidney Disease Improving Global Outcomes 2013).

In searching for predicting factors of renal decline in T2D, the same components that actively play a role in its pathogenesis, like insulin resistance, hyperglycemia, advanced glycation end products, hypertension, hyperlipidemia, and oxidative stress, have been found to largely contribute to its progression. Indeed, the components of metabolic syndrome seem to be related to the non-proteinuric phenotype, as obesity, high systolic pressure, and high triglyceride levels might concur in the development of reduced renal function.

In addition, numerous studies reported a consisted evidence of sex-specific pathways of renal damage; whereas male gender is generally associated with the worst outcome in chronic kidney disease, women with T2D are at greater risk for accelerated GFR decrease in the absence of proteinuria (Penno et al. 2012). Hormonal changes after menopause might interact with insulin resistance trait, thus stimulating renal damage in women; however, the few studies, addressing the question whether estrogen supplementation could be beneficial, have reported controversial results.

(c) *Retinopathy Is Not Invariably Associated with DN*

Another prevailing concept – that diabetic retinopathy strongly suggests the concurrent presence of renal disease – has been questioned, with stronger evidence in T2D. In the RIACE cohort, the majority of subjects (51.9%) had neither complication; discordance between retinal and renal damage was observed in 36.6% of subjects (10.6% with retinopathy only and 26.0% with DN only), whereas concordance was found only in 11.5% of individuals, a much lower percentage that in type 1 diabetes (Solini et al. 2012; Penno et al. 2012).

The reduced prevalence of retinopathy in patients with chronic kidney disease (CKD) and normoalbuminuria might exclude microangiopathy as a cause of the non-proteinuric GFR decrease and might suggest a role of macroangiopathy in the pathogenesis of this phenotype. In accordance with this hypothesis, reduced GFR without albuminuria was positively related to a significant cardiovascular burden, higher than albuminuria alone, whereas the combination of reduced GFR and albuminuria marked a further increased risk of cardiovascular events in an additive model. Lastly, creatinine and GFR trajectories were significantly associated with the occurrence of a major adverse cardiovascular event (MACE) in individuals with T2D; a more rapid renal function decline was associated with a higher risk of occurrence of a MACE (Ragot et al. 2016).

## **Additional Renal Complications**

Diabetic patients have a higher incidence of many other renal and urinary tract diseases. Urinary and genitourinary tract infections, both bacterial and fungal, are more frequent in diabetics. The risk is especially increased in patients with poor metabolic control and glycosuria. The incidence of pyelonephritis and intrarenal and perinephric abscess is increased, and their prognosis is more severe.

Prerenal azotemia, drugs, and contrast media-induced acute tubular necrosis are more frequent in diabetics, especially if proteinuria is present, with diabetes representing an additional risk factor for any acute renal disease. In acute renal failure, recovery of function is more often delayed or incomplete. Undiagnosed episodes of renal insufficiency may contribute to the previously discussed non-proteinuric decline in renal function, often observed in T2D. Renal artery stenosis is more frequent; it is associated with other macrovascular complications and may cause a sudden decline in renal function after the initiation of ACE inhibitor or AT1 receptor blockers or NSAIDs.

Similarly, subclinical episodes of hypovolemic or contrast media-induced acute renal insufficiency and long-term drug-related renal impairment (proton pump inhibitors, ACE inhibitors or AT1 receptor blockers, NSAIDs) may play a role.

---

## Management of the Renal Damage in Diabetes

### The Role of the Glucose Control

Randomized controlled studies have largely demonstrated that achieving and maintaining a better glycemic control reduces the development of microvascular complications. Two key interventional trials, involving subjects with T1D and T2D, asserted the importance of metabolic control. The Diabetes Control and Complications Trial (DCCT 1993) reported that in 1441 T1D patients with mild or no retinopathy at the baseline, intensive insulin therapy decreased microalbuminuria onset by 39% and macroalbuminuria development by 54% during a median follow-up of 6.5 years (DCCT 1993). In the UK Prospective Diabetes Study (UKPDS 1998) Group, 3867 newly diagnosed patients with T2D were randomly assigned intensive policy with a sulfonylurea or insulin, or conventional policy with diet, thus achieving over 10 years an HbA1c value of 7% and 7.9%. Irrespective of the used drug, intensive blood glucose control significantly decreased the risk of microvascular complications, but not of macrovascular disease (UKPDS 1998). Additional clinical trials, including the more recent long-term follow-up results of the Action in Diabetes and Vascular Disease: Preterax and Diamicon MR Controlled Evaluation Post-Trial Observational (ADVANCE-ON) study, have strengthened this concept (Zoungas et al. 2014).

However, while an intensive glycemic control invariably prevents or improves albuminuria, a less evident effect is observed with the respect of other clinical renal endpoints, i.e., progressive decrease in GFR; therefore, a substantial residual risk to develop ESRD still remains. It should be noted also that the main outcome of abovementioned trials was the prevention of the onset of microalbuminuria or the progression to macroalbuminuria; thus they could not be directly applied to the most advanced forms of nephropathy.

The 2012 update of the KDOQI (Kidney Disease Outcomes Quality Initiative) for diabetes and CKD recommends an HbA1c target of 7% to prevent or delay microvascular complications of diabetes, including DN, suggesting a less ambitious target

only in patients with a limited life expectancy or with significant comorbidities or at high risk of hypoglycemia (Kidney Disease Improving Global Outcomes 2013). This “patient-centered approach” is in accordance with the latest available statement of EASD/ADA (2016) (Standard of medical care in diabetes 2016).

The kidney plays a key role in the pharmacokinetic properties of antidiabetic drugs, and particularly of oral agents; thus, in the view of an individualized therapy, other than mechanism of action and clinical indications, the degree of renal function must be considered. The situation is even more complex in the frail elderly, where often the presence of kidney damage and the need for polypharmacy coexist. In this perspective, antidiabetic agents can be divided in those having a detrimental, neutral, or even beneficial effect on renal function. Indeed, recent data have revealed that particularly some classes, like incretins and SGLT2 inhibitors, present nephroprotective properties beyond their effect on glycemic control (Scherthaner et al. 2014).

Metformin is the first choice among drugs used for the treatment of T2D, mainly due to several advantages: a proven antihyperglycemic effect, a good safety profile with virtually no risk of hypoglycemia, the efficacy in preventing micro- and macrovascular complications, and its modest cost.

Metformin is primarily absorbed by the small intestine and excreted unchanged in the urine. Its half-life in patients with preserved renal function taking multiple doses is approximately 5 hours; the mean renal clearance is about 3.5 times higher than creatinine. It should be emphasized that changes in the pharmacokinetics of metformin are essentially reflected by the reduction in GFR. Previous reports had shown a prolonged half-life of metformin among patients with chronic renal disease, placing them at increased risk of lactic acidosis, a very rare but serious metabolic complication (3.3–4.3 cases/100,000 patient-years): accumulation of metformin could lead to raised concentrations of lactate, one of the precursors in the gluconeogenesis process, which has been inhibited by the action of the drug (Holstein and Stumvoll 2005).

Thus, the US Food and Drug Administration (FDA) and European Medicines Agency (EMA) have stated that metformin is contraindicated among individuals with renal disease, as indicated by serum creatinine  $>1.4$  mg/dL for women and  $1.5$  mg/dL for men, or abnormal creatinine clearance, which may result from conditions such as cardiovascular collapse (shock), acute myocardial infarction, and septicemia. However, as the benefits of metformin have become more widely appreciated, there has been an ongoing debate as to whether these serum creatinine thresholds are too conservative and whether the beneficial effects of metformin outweigh potential harms among individuals with mild-to-moderate CKD. Moreover, data from the cross-sectional analysis suggest how wide the use of metformin in such patients is spread in real-life experience, taking advantage of the associated cardiovascular protection (Solini 2013). At the same time, evidence has accumulated that serum creatinine leads to substantial misclassification in identifying individuals with chronic kidney disease and that eGFR is a more accurate estimation of an individual's kidney function. Therefore, the current guidelines have established that metformin is the first-line choice in patients with mild CKD, defined by eGFR  $>45$  mL/min/1.73 m<sup>2</sup>; it can be used reducing the dosage by 50% in those patients

with eGFR 30–45 mL/min/1.73 m<sup>2</sup>, while it is contraindicated in severe chronic renal impairment (eGFR <30 mL/min/1.73 m<sup>2</sup>) (Molitch et al. 2015).

When metformin is insufficient, the EASD/ADA guidelines indicate sulfonylureas (SU), glitazones, incretin-based therapies, SGLT2 inhibitors, or insulin itself as second-line drugs to be added to metformin or to replace it, if not tolerated. The majority of SU, still widely used in the treatment of T2D, is excreted by the kidneys, some of them as active metabolites. Molecules of the first generation (acetohexamide, chlorpropamide, tolazamide, tolbutamide), whose metabolites may reach elevated plasma concentrations in the presence of renal dysfunction, enhance the occurrence of hypoglycemia, itself favored by low glycogen stores and impaired renal gluconeogenesis, being therefore associated with a risk of severe hypoglycemia and excess of mortality, particularly in the elderly and in patients with reduced GFR; this is partially true also for more recent SU. In a cohort of more than 90,000 diabetics in the Veterans Administration, those taking SU (glibenclamide, glyburide, and glipizide) had a higher risk of adverse renal events (persistent reduction in GFR >25% or ESRD), as well as of hypertension and mortality, compared to patients treated with metformin (Roumie et al. 2012). Moreover, although in the UKPDS the benefits on renal outcomes were independent of the antihyperglycemic agents used, a large retrospective study has recently reported that the risk of eGFR decline, ESRD, or death was higher with SU than with metformin or rosiglitazone (Hung et al. 2012).

Thiazolidinediones (TZDs) are metabolized by the liver and are not excreted by the kidney, not requiring any dose adjustment in patients with CKD. Nevertheless, their safety has been widely debated in recent years and especially in patients with CKD: the risk of fluid retention and congestive heart failure, well-known adverse events associated with the use of TZDs, has to be particularly considered in fragile patients with CKD.

Incretins, instead, have shown a renoprotective effect, which is included among the numerous extra-pancreatic functions that these molecules exert beyond their primary role of stimulating insulin secretion from pancreatic  $\beta$ -cells. This class includes oral agents (dipeptidyl peptidase-4 [DPP-4] inhibitors) and injective GLP-1 analogs. One of the key differentiators of the available DPP-4 inhibitors is the route of elimination, with sitagliptin, vildagliptin, saxagliptin, and alogliptin displaying a variable renal elimination route ranging from 75% for saxagliptin to 87% for sitagliptin; in comparison, less than 6% of linagliptin is excreted by the kidney; thus adjustment in case of renal impairment is not needed.

Injective compounds are predominantly excreted via the kidney, limiting their use in subjects with impaired renal function. The use of exenatide and liraglutide has been linked to sporadic cases of acute renal failure, likely due to the side effects of gastrointestinal with recurrent vomiting and dehydration.

Placebo-controlled studies with incretins have pointed out the substantial positive benefit-risk profile of patients with T2D and mild-to-severe renal impairment, while no conclusive evidence was reported for ESRD (Howse et al. 2016). Clinical trials, comparing DPP-4 inhibitors with SU, have defined a better profile in the efficacy and safety of the incretin-based therapy (Deacon and Lebovitz 2016). Moreover,

experimental studies using various diabetic models suggest that incretins, by the effect of GLP-1, prevent the endothelium injury, thereby reducing oxidative stress and the local inflammatory response, which in turn decrease albuminuria and inhibit glomerular sclerosis. There is also evidence that GLP-1 receptor agonists and DPP-4 inhibitors facilitate sodium excretion and diuresis to lower blood pressure. The pleiotropic actions of DPP-4 inhibitors are ascribed primarily to their effects on GLP-1 signaling, but other substrates of DPP-4, such as brain natriuretic peptide and stromal-derived factor-1a, may have roles (Tanaka et al. 2014). The growing proofs of the anti-fibrotic and anti-inflammatory actions of these molecules have led to the design of randomized clinical trials that should provide reliable clinical data on surrogate and hard renal outcomes in high-risk population of diabetic patients and renal disease (Groop et al. 2015). Of note, very recent data coming from large post-marketing trials aimed at assessing the non-inferiority of GLP-1 analogs versus the older oral hypoglycemic agents in terms of cardiovascular safety suggest an intriguing renoprotective effect exerted by liraglutide and semaglutide (Marso et al. 2016b).

No doubt SGLT2 inhibitors are the most intriguing novel hypoglycemic agents (Kohan et al. 2014). This relatively new class, including the better known canagliflozin, dapagliflozin, and empagliflozin together with incoming novel molecules, exerts their effect by preventing sodium and glucose reabsorption by SGLT2 in the S1 segment of renal proximal tubule, thus leading to glycosuria and reduced plasma glucose levels. Their mode of action is strictly dependent upon the glucose filtered load, and therefore GFR, so that a decrease in renal function parallels with a reduction in glucose-lowering activity. On the basis of efficacy and safety trials, it has been recommended to avoid their use in patients with  $eGFR < 60 \text{ mL/min/1.73 m}^2$  at the baseline and to stop it in case of  $eGFR < 45 \text{ mL/min/1.73 m}^2$ . Despite the reduction of their antihyperglycemic effect in the presence of a reduced renal function, SGLT2 inhibitor administration seems to promote a recovery of glomerular hyperfiltration, a determinant of progressive renal disease in T2D patients, likely through mechanisms of tubular-glomerular feedback, therefore normalizing filtration pressure and attenuating the loss of podocytes and nephrons and restoring the submaximal GFR (Cherney et al. 2014; Anders et al. 2016). A recent meta-analysis including the most recent trials like EMPA-REG OUTCOME, the CANVAS Program, and DECLARE-TIMI 58, shows that SGLT2 inhibitors, through several and partially known mechanisms, have a robust effect on reducing the relative risk of CV disease, hospitalization for heart failure and progression of renal disease (Zelniker et al. 2019).

SGLT inhibitors are associated with an initial phase of decline in GFR, whose duration is 7–10 days in healthy subjects but may be longer and more pronounced in subjects with renal impairment. This phase is revertible with the withdrawal of the drug, thus indicating a hemodynamic phenomenon and not a true renal injury, and is rapidly followed by a recovery with restoration of baseline levels. Besides glucose control, SGLT2 inhibitors exert a series of ancillary clinical actions potentially able to protect the kidney, like an antihypertensive effect due to volume depletion, a weight loss, and a decrease in uric acid (both obesity and hyperuricemia are independent risk factors for DN and for progression of CKD). Moreover, data obtained in animal models and in humans suggest that SGLT2 inhibitors have intrinsic renal hemodynamic effects, determining a reduction of hyperfiltration and

intraglomerular pressure. In diabetic mice model, gliflozins decrease urinary albumin/creatinine ratio, improve GFR, and reduce several effectors of renal inflammatory response; in the same animal model, it was observed an increase in the phosphorylation of the Na-H exchanger NHE3 that participates to the proximal tubular bicarbonate reabsorption, reducing its activity and therefore contributing to enhance urinary  $\text{Na}^+$  excretion and to prevent glomerular hyperfiltration (Cherney et al. 2014). Additional studies have shown a potential benefit by selectively enhancing the vasoconstriction of the afferent arteriole, thus preventing the increase in intraglomerular pressure. An interesting study explored the effect of empagliflozin as add-on to insulin treatment in 40 T1D patients, who were normotensive and have a  $\text{eGFR} > 60 \text{ mL/min/1.73 m}^2$ . In those presenting a hyperfiltration at the baseline, 8 weeks of treatment resulted in a reduction of GFR, whereas those having a normal GFR were not affected. In association with this 20% reduction in GFR, there was a parallel reduction in renal plasma flow and increase in renal vascular resistance, likely consequent of afferent arteriolar vasoconstriction. The reduction in GFR during empagliflozin treatment was not mediated by the renin-angiotensin system (RAS), as there was an increase in both angiotensin II and aldosterone levels as the result of the diuretic effect (Cherney et al. 2014).

Besides exploratory pilot studies, larger clinical trials have confirmed renal benefits of SGLT2 inhibition. In patients with stage 3 CKD, dapagliflozin reduced albumin-to-creatinine ratio (Kohan et al. 2014); in a post hoc analysis of the study, this result was maintained after adjustment for blood pressure, HbA1c, and GFR, suggesting a direct renal effect. Similar data were reported in patients treated with canagliflozin (Yale et al. 2014). The analysis on secondary renal endpoints of the Cardiovascular Outcome Event Trial in Type 2 Diabetes Mellitus Patients (EMPA-REG OUTCOME) trial, designed to compare the effects of empagliflozin versus placebo on cardiovascular outcomes in patients with T2D and high cardiovascular risk, showed a 46% reduction in the risk of renal composite outcome (doubling of serum creatinine with an  $\text{eGFR}$  of  $45 \text{ mL/min/1.73 m}^2$  or less, need of renal replacement therapy, death due to renal disease) over a mean follow-up of 5 years (Wanner et al. 2016). A global evaluation of the more recent trials suggest that SGLT2 inhibitors reduce the composite endpoint of worsening of renal function, end-stage renal disease (ESRD), or renal death by 45% across all baseline GFR levels. Recently, the renoprotection of canagliflozin in type 2 diabetes was further explored in the CREDENCE trial, specifically enrolling macroalbuminuric patients with GFR of 30 to  $< 90 \text{ mL/min/1.73 m}^2$  (Perkovic et al. 2019). Intriguingly, the relative risk of the primary outcome was nearly 30% lower in the Canagliflozin group than in the placebo group, opening new relevant challenges in the possibility of reduce the widespread of ESRD.

## Insulin Treatment

The kidney accounts for almost 50% of the insulin clearance from the systemic circulation by two distinct steps. The first pathway consists of glomerular filtration and subsequent absorption of insulin by proximal tubular cells through endocytosis;

the second involves insulin diffusion through the peritubular capillaries and its binding to the contraluminal cell tubular membrane, mainly at the level of the distal half of the nephron. Therefore, insulin is transported by lysosomes and is metabolized into amino acids released into the peritubular vessels by diffusion, with the final reabsorption of the degradation products (Duckworth and Kitabchi 1981). Since exogenous insulin skips the first-pass effect in the liver, the kidney plays a relevant role in its metabolism and clearance; this must be obviously considered when treating patients with renal impairment. With the progression of renal damage, the peritubular uptake rises to compensate for the reduction of glomerular filtration, thus maintaining an adequate insulin clearance; however, when GFR decreases below a threshold of 20 mL/min, this compensatory mechanism fails, dramatically increasing the risk of hypoglycemic events. Accordingly, it has been suggested no dose adjustment of any insulin regimen when GFR is >50 mL/min, although a lower dosage can be observed, and a reduction to a 75% and to a 50% of the total daily requirement in case of GFR 10–50 mL/min and GFR >10 mL/min, respectively (Snyder and Berns 2004).

Nowadays, insulin treatment consists of the prevailing use of insulin analogs, which are produced thanks to DNA recombinant technology. They include short-acting (lispro, aspart, or glulisine insulin) analogs for the prandial requirement and long (glargine, detemir) or ultra-long-acting insulin (degludec) analogs for basal requirement. When used in combination, these molecules can mimic physiological insulin profiles more closely than the old regular or neutral protamine Hagedorn (NPH) insulin.

Recent results suggest that treatment of T1D patients with normal and impaired renal function with insulin analogs, especially glargine and lispro, may be associated with a more beneficial profile in terms of kidney function, reduction of urinary albumin excretion rate, along with a better glucose control compared to treatment with human insulin (Hasslacher et al. 2016).

Few studies have examined and compared the pharmacokinetic profile of long-acting analogs. In a study involving T1D participants stratified according to renal function, the insulin dosage at eGFR <60 mL/min was 29.7% lower in glargine-treated and 27.3% lower in detemir-treated patients compared with eGFR >90 mL/min (Kulozik and Hasslacher 2013). The new-generation ultra-long analog appears to be particularly safe, even in patients with ESRD; in a small study (30 T2D subjects), no significant differences in absorption or clearance were observed across all the renal function classes, suggesting that no adjustment is needed in patients with CKD (Kiss et al. 2014). Ongoing trials are carrying out with the aim of comparing the safety profile insulin glargine with degludec in at-risk cardiovascular population (Marso et al. 2016).

The short-acting analogs usually reach their plasmatic concentration after approximately 60–90 min and have a duration of action of 3–4 h. Among them, insulin lispro is the most investigated analog, which maintains its pharmacokinetic properties even in the presence of severe renal impairment. Moreover, studies in a set of patients undergoing hemodialysis treatment suggested that the use of this analog can provide better glycemic control and improve quality of life (Czock et al. 2003). Nevertheless, renal impairment does not affect the pharmacokinetics of the other insulin analogs in a clinically significant manner (Urata et al. 2015; Holmes et al. 2005).

## Glomerular Hemodynamic and Blood Pressure Control

Renal hemodynamic changes induced by diabetes were first identified by Hostetter et al. (1981) in an animal model of streptozotocin-induced diabetes describing an increase in single nephron glomerular filtration rate and capillary pressure. The elevations in glomerular blood flow, filtration, and hydraulic pressure were secondary to a decline in vascular resistance of the afferent arteriole that was unmatched by a comparable decline in the efferent arteriolar tone. It was hypothesized that the resultant glomerular hypertension would contribute to the rise in GFR that characterizes the early stages of diabetes and would eventually lead to glomerular damage and renal insufficiency. Various mechanisms have been put forward to explain the abovementioned arteriolar vasodilatation and hemodynamic changes. Among these, hyperglycemia seems to play a major role in the pathogenesis of the disrupted glomerular vasoregulation. High glucose levels induce a local activation of the renin-angiotensin-aldosterone system (RAAS). The efferent arteriole is more sensitive to the hemodynamic effect of angiotensin II, and this may contribute to the hemodynamic imbalance. To this regard, studies on the protective role of ACE inhibitors on the development of hemodynamic changes and proteinuria support the role of RAAS in the pathogenesis of the disease.

Hyperglycemia may also contribute to the pathogenesis of glomerular vasodilatation and hyperfiltration inducing an imbalance of the tubule-glomerular feedback. Under euglycemic conditions, glucose is filtered in the glomerulus, and it is entirely reabsorbed in the proximal tubule, with approximately 60% of the filtered sodium load cotransported and reabsorbed with glucose. When circulating glucose levels are elevated and exceed the maximal tubular glucose transport, glycosuria occurs. In diabetics, long-term tubular glucose reabsorption is enhanced, the threshold for glycosuria is increased, and sodium reabsorption in the proximal tubule is also increased (Gnudi and Karalliedde 2016). As a result, during chronic hyperglycemia the distal delivery of sodium to the macula densa is reduced. This is sensed as a stimulus to enhance glomerular filtration via the paracrine and endocrine secretion of both vasodilator and vasoconstrictor. Recent data on the renal hemodynamic effects of SGLT2 inhibitor empagliflozin in T1D showing a decline in GFR of hyperfiltering patients but not of normofiltering ones are supportive for a significant role of distal sodium delivery and tubule-glomerular feedback in the regulation of GFR during hyperglycemia. It is likely that both the abovementioned mechanisms, RAAS activation and tubule-glomerular feedback, and the activation of various other signaling pathways play a role in the development of glomerular hyperfiltration and hypertrophy.

Glomerular hypertension also induces a mechanical strain on capillary endothelial cells which is reflected to podocytes and mesangial cells whose structure, morphology, and functions are already impaired by the altered metabolic environment secondary to hyperglycemia (Gnudi and Karalliedde 2016). However, many other regulatory, signaling, and inflammatory pathways are activated in the glomerulus, and they contribute to the highly complex pathogenesis of diabetic kidney disease (Gnudi and Karalliedde 2016).



Supportive evidences for a role of hemodynamic changes in diabetic nephropathy are derived from clinical and experimental data on the favorable effects of RAAS inhibition on the development and progression of DN. Zatz et al. (1986) reported studies in Munich Wistar rats with diabetes showing that the ACE inhibitor enalapril reduced vascular resistance of the efferent glomerular arteriole and ameliorated transcappillary glomerular pressure and damage. These effects were independent from the antihypertensive effects of enalapril or blood glucose levels. In their seminal work, Lewis et al. (1993) reported the results of a controlled trial in T1D patients designed to evaluate the effects of the ACE inhibitor captopril in slowing the progression of DN in comparison with other antihypertensive agents. At baseline, patients had either a urinary protein excretion greater than 500 mg or a moderate GFR decline. The protective effect of ACE inhibition was more pronounced in patients with more advanced forms of the disease. Results supported the hypothesis that ACE inhibitors could slow the progression of DN by a mechanism that is independent of their antihypertensive properties.

In later years, clinical evidences accumulated on the effects of pharmacologic intervention in the various stages of diabetic kidney disease both in T1D and T2D patients. In T1D various clinical trials enrolling more than 700 patients tested the effects of ACE inhibitors on the clinical course of microalbuminuria. A meta-analysis of individual patient data confirmed that ACE inhibitors significantly reduced progression to more advanced nephropathy and increased the rate of regression from microalbuminuria to normoalbuminuria in T1D patients (ACEi Trialist Group 2001). The effect was evident also in normotensive microalbuminuric individuals. Albeit no specific side effects are reported, it is suggested to start ACE inhibitor treatment with low dose and then titrate to the maximum tolerated dose, with a regular monitoring of blood pressure, potassium levels, and renal function. A moderate decline of GFR is expected and may be tolerated. Because of the strong evidences available with ACE inhibitor treatment, neither placebo-controlled studies employing ARBs nor direct comparison of ACE inhibitors versus ARBs has been performed. Nevertheless, in T1D with sign of renal involvement, it is conceivable to use ARB as an alternative to ACE inhibitors if clinically indicated.

As far as target blood pressure levels are concerned, no randomized controlled trial has directly addressed this issue. A blood pressure target of 140/90 or less is advocated by most guidelines. No direct evidence (Standards of Medical Care in Diabetes 2016) is available on additional antihypertensive agents to be used in addition to ACE inhibitors or ARBs.

In more advanced stages of DN, the only randomized controlled trial has been performed with captopril (Lewis et al. 1993; Fig. 2). At this stage of the disease, the use of ACE inhibitors or ARBs is strongly advocated by all guidelines (Standards of Medical Care in Diabetes 2016). No direct comparison between ACEi and ARBs is available, and their association is not recommended. Attention should be focused to the risk of sudden worsening of renal function or hyperkalemia. In T1D, when clinically overt proteinuria occurs, blood pressure levels tend to increase. Although no direct randomized controlled studies have addressed the issue, various observational studies have reported a more rapid decline of renal function if blood pressure is

### The Collaborative Study

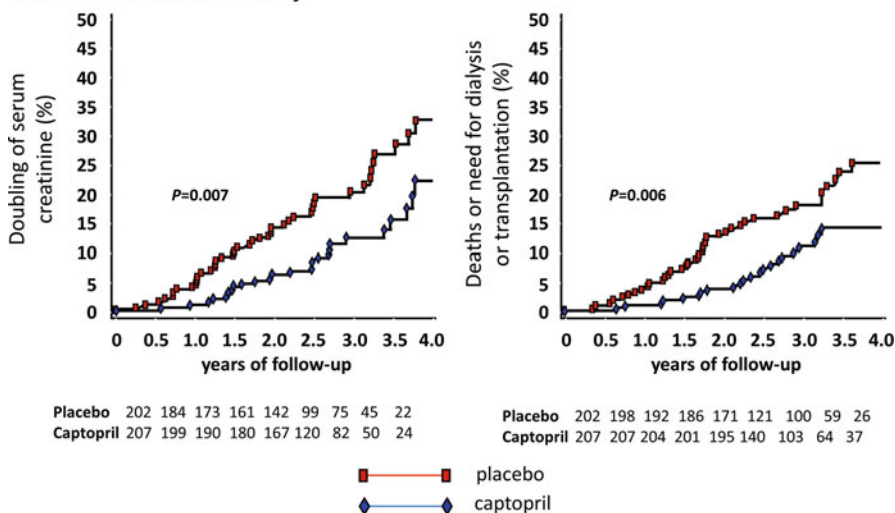

**Fig. 2** Efficacy of ACE inhibitors in proteinuric T1D patients. (Adapted from Lewis et al. 1993)

uncontrolled and a beneficial effect of maintaining blood pressure at or below 140/90 mm Hg. Results on the effects of ACE inhibitor or ARB treatment in preventing the onset of microalbuminuria in normoalbuminuric T1D individuals are disappointing. The EUCLID study evaluated the effect treatment with lisinopril or placebo in T1D with normoalbuminuria or microalbuminuria. After 2 years of follow-up, the positive effects of RAAS inhibition were restricted to patients with microalbuminuria at baseline, but lisinopril failed to modify the clinical course of patients with no albuminuria at the time of randomization. Similar negative results were obtained with candesartan, enalapril, and losartan (Shilpak 2010). As a result, in T1D patients with no clinical evidences of nephropathy, who have normal blood pressure, normoalbuminuria, and normal eGFR, the use ACE inhibitor or ARBs for the primary prevention of diabetic kidney disease is not recommended (Standards of Medical Care in Diabetes 2016). In this clinical setting, the prognostic value of isolated glomerular hyperfiltration is still unclear, and tight blood glucose control may represent the most relevant therapeutic goal.

A minority of T1D patients may develop progressive decline of renal function with no previous evidence of micro- or overt proteinuria (Perkins 2009). The appropriate treatment of this subgroup of patients is still a matter of debate.

In T2D, four randomized controlled studies have evaluated the effects of ACE inhibitors on the outcome of patients with microalbuminuria. Two studies evaluated the effect of intermediate doses of enalapril (10 mg/day) showing a significantly reduced progression to advanced nephropathy at 5 years when compared to placebo. Similar data were obtained with full doses of ramipril (10 mg/day) but not with doses (1.25 mg/day) below that was currently used in clinical practice (Shilpak 2010). In a 2-year controlled randomized study by Parving et al. (2001), irbesartan (300 mg/day)

reduced the progression from microalbuminuria to overt nephropathy in comparison with placebo (5% vs. 15%, respectively); lower doses of irbesartan (150 mg/day) were not effective. Barnett et al. (2004, NEJM) directly compared the effects of high doses of telmisartan (80 mg/day) and moderate doses of enalapril (20 mg/day) on total and cardiovascular mortality and changes in renal function in 250 T2D patients with early nephropathy. After 5 years of follow-up, no difference between the two drugs was observed. Various studies have investigated if a more aggressive treatment designed to obtain lower blood pressure levels or higher doses of ACE inhibitors or ARBs may provide additional protective effects of progression of nephropathy. However, intensive treatments determined a higher rate of cardiovascular events and acute renal insufficiency; therefore they are not recommended. Similarly, the use of combination therapy with ACE inhibitors and ARBs is associated with higher rates of hyperkalemia and acute renal insufficiency.

In advanced nephropathy, two studies have evaluated the effects of ARB treatment on disease progression. Lewis et al. (2001) compared an amlodipine- and an irbesartan-based treatment regimens versus conventional treatment; Brenner et al. (2001) evaluated the effect of losartan versus conventional treatment. Both studies demonstrated an advantage of the ARB-based therapeutic regimens on renal disease progression but not on overall mortality. In a post hoc analysis, it was shown that the degree of proteinuria correlated with the disease progression and mortality and the decline of urinary protein excretion during treatment was predictive of a more favorable outcome. Studies that evaluated the effects of ACE inhibitors and ARBs in combination therapy observed higher rate of adverse effects with no additional renal protection; therefore these therapeutic regimens are not recommended.

Forty to fifty percent of T2D with microalbuminuria eventually experience major cardiovascular events or renal disease progression. Therefore many studies have focused on preventing the onset of microalbuminuria in normoalbuminuric individuals. The J MIND Study reported a lower incidence of new onset microalbuminuria in T2D patients following a 2-year treatment with enalapril versus nifedipine. However, the study was underpowered, and the data on a specific treatment effect were inconclusive. In the diabetic subgroup of the HOPE Study, ramipril treatment determined a reduced incidence of cardiovascular events and a lower onset of microalbuminuria (HOPE 2000). A large randomized prospective study (BENEDICT) was designed to assess the effects of an ACE inhibitor (trandolapril), a non-dihydropyridine calcium channel blockers (verapamil), or their combination on the prevention of persistent microalbuminuria in a large cohort of T2D patients. Over 3.5 years microalbuminuria developed in approximately 6% of patients on ACE inhibitor-based regimens and 12% of verapamil-based or placebo regimens (Ruggenenti et al. 2004). The effect was more evident in hypertensive patients, and reduction of blood pressure was independently associated with a favorable outcome.

In the ROADMAP Study (Haller et al. 2011), olmesartan treatment was associated with a 20% decline in the development of new microalbuminuria versus a non-ARB or ACE inhibitor-based control group (8% vs. 10%, respectively); 70% of patients achieved blood pressure levels lower than 130/80 mmHg in both study

groups. However a concerning number of fatal myocardial infarction occurred in the olmesartan group. There were more deaths from cardiovascular causes in the olmesartan group than in the placebo group (15 vs. 3,  $P = 0.01$ ). Fatal cardiovascular events were more common among patients with known pre-existing coronary heart disease who were either in the lowest quartile of blood pressure or in the highest quartile of blood pressure reduction during follow-up.

The effects of ACE inhibitors or ARBs may be offset by a rise in renin release. Aliskiren is a renin inhibitor developed for clinical use. In the ALTITUDE trial (Parving et al. 2012) patients were randomly assigned in a double-blind fashion to aliskiren (300 mg daily) or placebo as add-on to an ACE inhibitor or an ARB. The primary endpoint was a composite fatal and nonfatal cardiovascular and renal event. The trial was stopped prematurely after a median follow-up of 32.9 months; events were similar in the two groups, but the proportion of patients with hyperkalemia and reported hypotension was significantly higher in the aliskiren than in the placebo group. These data confirm that an overzealous inhibition of the RAAS and/or blood pressure levels lower than 130 mmHg are not advantageous and may even be potentially harmful in very high-risk patients.

---

## Diabetic Nephropathy and Cardiovascular Disease

### Epidemiology

In recent years, a number of studies have demonstrated the extremely high risk of cardiovascular disease (CVD) in patients with CKD. Data coming from the 2016 annual report of the US Renal Data System show, among those not carrying any CKD, the prevalence of chronic heart failure is approximately 7%; 16% of these patients have an atherosclerotic CVD and 4% of them had an acute myocardial infarction; these percentages are approximately threefold higher in patients with CKD (USRDS 2016). Patients with CKD stage 3 ( $eGFR \leq 60$  mL/min/1.73 m<sup>2</sup>) have a tenfold higher risk of death than of progression to ESRD (Eriksen and Ingebretsen 2006); a number of these deaths are due to sudden cardiac death, arrhythmia, congestive heart failure, or stroke. No doubt this risk increases exponentially in patients carrying diabetes and CKD together: the Alberta Kidney Disease Network (more than one million and two hundred thousand participants) shows, when considering the mortality due to myocardial infarction or, even more, the all-cause mortality, diabetes itself and CKD itself increase the risk by a relevant amount, but such risk is maximized in patients with diabetes and CKD (Tonelli et al. 2012).

The relationship between CKD and CVD is very complex, and a proper classification of a patient with diabetes and CKD is of paramount importance in stratifying his/her CV risk. Population-based studies and ample meta-analyses have documented as a  $GFR < 60$  and presence of albuminuria are independent predictors of all-cause mortality and CV mortality in the general population (Bello et al. 2011); however, the combined presence of decreased  $eGFR$  and albuminuria was multiplicatively associated with CV mortality (Matsushita et al. 2010). This is also evident in

more true in T2D, where altered albumin excretion is a marker of either renal damage or cardiovascular risk: data from the UKPDS Study show increased albuminuria is coupled with increased mortality, and every year, approximately 5% of patients with macroalbuminuria and 20% of patients with advanced diabetic nephropathy die for any cause (Adler et al. 2003). In T2D patients the risk raises exponentially when an increased albumin excretion rate is combined with a strong GFR reduction. In the ADVANCE Study, the increased albuminuria and the reduced GFR are associated in an independent and continuous manner, with either cardiovascular or renal events: macroalbuminuric patients with GFR <60 have a threefold increased cardiovascular risk, a sixfold increase risk of cardiovascular mortality, and a 22-fold increased risk to develop renal events. In this study, an increased risk of cardiovascular mortality related to the presence of albuminuria has been also reported (Zoungas et al. 2014).

Similarly, the prospective data of the FIELD Study show a remarkable increase of the cumulative CV risk in patients where albuminuria and reduced GFR coexist (Drury et al. 2011). It is interesting to underline that, dealing with the risk to develop CV events, it is more unfavorable to have a reduced GFR, even with normal albumin excretion, rather than albuminuria.

An analysis of prospective data of the DIAMETRIC, a consortium that includes patients from some important clinical trials like IDNT and RENAAL, has tried to address a very important issue, i.e., to establish whether ESRD is a more common outcome than CV death in patients with advanced renal damage and proteinuria in over 3200 patients with the evaluation of ESRD incidence, CV mortality, and all-cause mortality. The mean follow-up was 2.8 years; 19.5% of the patients developed ESRD, the hazard ratio for CV mortality was 2.5, and the hazard ratio for all-cause mortality was 1.5 (Packham et al. 2012). Therefore, even considering all the limitations of a prospective clinical trial, patients with T2D and advanced nephropathy seem to be more at risk to proceed toward the ESRD rather than to die along the first 3 years. It is easy to recognize the relevant clinical implications of these observations, for example, in terms of programming and regulating when and how starting dialysis.

## **Mechanisms of Macrovascular Damage in Patients with Diabetes and CKD**

In an attempt to identify peculiar mechanism of vascular damage in these patients, it is important to start with a proper definition of atherosclerosis and arteriosclerosis. Atherosclerosis is characterized by intimal thickening and loss of conduit function, associated with intimal calcification, is probably not induced, but is aggravated by CKD, and its severity could be affected by changes in plaque composition rather than by atheromatous plaque number or volume. Arteriosclerosis is characterized by arterial stiffening and loss of cushioning function, associated with left ventricular diastolic dysfunction and hypertrophy and cardiomyopathy, and, in the late stages, medial calcification is likely the main cause of CVD in patients with CKD (Moody et al. 2013). In patients with chronic diseases like diabetes or hypertension,

atherosclerosis is characterized by an increased arterial stiffness, indicated by the pulse-wave velocity value; this characteristic is enhanced according to the progression of renal damage: the more pronounced is the renal impairment, the more serious is arterial stiffness. Relevant studies have also tried to characterize the status of intraparenchymal renal resistances in normoalbuminuric patients with reduced GFR, showing patients with  $\text{GFR} < 60 \text{ mL/min/1.73 m}^2$  had higher resistance index of interlobar arteries, and such index was similar independently upon the presence or absence of microalbuminuria (MacIsaac et al. 2006). It has been recently reported the dynamic renal resistive index, an ultrasonographic parameter recorded at the level of interlobar arteries, is reduced in normoalbuminuric neodiagnosed T2D individuals with respect to healthy controls and hypertensive patients; in a 4-year observational follow-up, a higher dynamic renal resistive index at baseline seems to predict the development of microalbuminuria in these patients, but not the GFR decline (Bruno et al. 2014).

Concerning the nature and composition of the atherosclerotic plaques, mechanisms throughout CKD might affect these parameters are numerous: for example, the increased production of adhesion molecules and chemotactic factors is a major determinant of an increased monocyte infiltration and macrophage trapping, as well as variations in the composition of the plaque matrix, with increased phenomena of oxidation and glycosylation and an increased retention of lipoproteins and cholesterol content of the cell membranes. All these processes induce a progressive increase of plaque instability. This concept has received a strong support from an autopsic study performed on 126 passed away people: the prevalence of advanced atherosclerotic lesions, defined as lesions from types IV to VI, was 34.3% for  $\text{eGFR} \geq 60 \text{ mL/min/1.73 m}^2$ , 41.7% for  $\text{eGFR}$  of 45–59, 52.3% for  $\text{eGFR}$  of 30–44, and 52.8% for  $\text{eGFR} < 30 \text{ mL/min/1.73 m}^2$ ; in other words, the percentage of more advanced and more serious lesions according to the classification of the American Heart Association progressively increased according to the degree, which means the severity, of chronic kidney disease (Nakano et al. 2010).

In the general population, coronary calcification and the degree of atherosclerosis are closely related with the amount of atherosclerosis; the presence of CKD and coronary calcification are common, and atherosclerotic plaques have higher calcium content compared with patients without CKD. In the study population of the Dallas Heart Study, it has been demonstrated an increased calcium score at the level of coronary arteries according to the degree of chronic renal function, and this is even more true in the subset of diabetic patients (Kramer et al. 2005). There also are data indicating that a high coronary calcium score is associated with an adverse prognosis in dialysis-dependent patients, although these studies contain relatively small numbers.

The presence of a relevant renal damage may directly influence the state of the left ventricle, in terms of both structure and function: an increased left ventricular mass, a reduction of the ejection fraction, an increased prevalence of left ventricular hypertrophy, and an increased percent of subjects with an ejection fraction lower than 55% are recognized when we move from a CKD stage 3 to higher stages (Chen et al. 2012).

In addition to the well-known mechanisms through which CKD influences CV morbidity and mortality in T2D patients, we should not forget the increased prevalence of hypoglycemic events in these frail patients, as well documented by a retrospective analysis of the VA Study, performed in more than 200,000 patients with a huge number of glucose determinations (Moen et al. 2009). Another major determinant of the high CV morbidity and mortality in these patients is the high prevalence of resistant hypertension, reported in 15% of the whole cohort patients of the RIACE Study but in 23% of those carrying CKD (Solini et al. 2014).

---

## References

- ACE inhibitor in diabetic nephropathy trialist group. Should all patients with type 1 diabetes mellitus and microalbuminuria receive angiotensin converting enzyme inhibitors? A meta analysis of individual patient data *Ann Intern Med.* 2001;134:370–9.
- Adler AI, Stevens RJ, Manley SE, et al. UKPDS GROUP. Development and progression of nephropathy in type 2 diabetes: the United Kingdom Prospective Diabetes Study (UKPDS 64). *Kidney Int.* 2003;63(1):225–32.
- American Diabetes Association. Standards of medical Care in Diabetes-2016: summary of revisions. *Diabetes Care.* 2016;39(Suppl 1):S4–5.
- Anders HJ, Davis JM, Thurau K. Nephron protection in diabetic kidney disease. *New Engl J Med.* 2016;375:2096–8.
- Barnett AH, Bain SC, Bouter P, et al. Angiotensin-receptor blockade versus converting-enzyme inhibition in type 2 diabetes and nephropathy. *N Engl J Med.* 2004;351:1952–61.
- Bello AK, Hemmelgarn B, Lloyd A, et al. Associations among estimated glomerular filtration rate, proteinuria, and adverse cardiovascular outcomes. *Clin J Am Soc Nephrol.* 2011;6(6):1418–26.
- Bertani T, Gambarà V, Remuzzi G. Structural basis of diabetic nephropathy in microalbuminuric NIDDM patients: a light microscopy study. *Diabetologia.* 1996;39(12):1625–8.
- Brenner BM, Cooper ME, de Zeeuw D, et al. Effects of losartan on renal and cardiovascular outcomes in patients with type 2 diabetes and nephropathy. *N Engl J Med.* 2001;345:861–9.
- Bruno RM, Salvati A, Barzacchi M, et al. Predictive value of dynamic renal resistive index (DRIN) for renal outcome in type 2 diabetes and essential hypertension: a prospective study. *Cardiovasc Diabetol.* 2014;14:63.
- Chen SC, Chang JM, Liu WC, et al. Stepwise increases in left ventricular mass index and decreases in left ventricular ejection fraction correspond with the stages of chronic kidney disease in diabetes patients. *Exp Diabetes Res.* 2012;2012:789325.
- Cherney DZ, Perkins BA, Soleymanlou N, et al. Renal hemodynamic effect of sodium-glucose cotransporter 2 inhibition in patients with type 1 diabetes mellitus. *Circulation.* 2014;129:587–97.
- Czock D, Aisenpreis U, Rasche FM, et al. Pharmacokinetics and pharmacodynamics of lispro-insulin in hemodialysis patients with diabetes mellitus. *Int J Clin Pharmacol Ther.* 2003;41(10):492–7.
- De Boer IH, Rue TC, Hall YN, et al. Temporal trends in the prevalence of diabetic kidney disease in the United States. *JAMA.* 2011;305:2532–9.
- Deacon CF, Lebovitz HE. Comparative review of dipeptidyl peptidase-4 inhibitors and sulphonylureas. *Diabetes Obes Metab.* 2016;18(4):333–47.
- Drury PL, Ting R, Zannino D, et al. Estimated glomerular filtration rate and albuminuria are independent predictors of cardiovascular events and death in type 2 diabetes mellitus: the Fenofibrate Intervention and Event Lowering in Diabetes (FIELD) study. *Diabetologia.* 2011;54(1):32–43.
- Duckworth WC, Kitabchi AE. Insulin metabolism and degradation. *Endocr Rev.* 1981;2(2):210–33.

- Eriksen BO, Ingebretsen OC. The progression of chronic kidney disease: a 10-year population-based study of the effects of gender and age. *Kidney Int.* 2006;69(2):375–82.
- Fiochetto P, Mauer M, Brocco E, et al. Patterns of renal injury in NIDDM patients with microalbuminuria. *Diabetologia.* 1996;39(12):1569–76.
- Fiochetto P, Steffes MW, Barbosa J, et al. Is diabetic nephropathy inherited? Studies of glomerular structure in type 1 diabetic sibling pairs. *Diabetes.* 1999;48:865–9.
- Gall MA, Hougaard P, Parving HH. Risk factors for development of incipient and overt diabetic nephropathy in patients with non-insulin dependent diabetes mellitus: prospective, observational study. *BMJ.* 1997;314(7083):783–8.
- Giorgino F, Laviola L, Cavallo Perin P, et al. Factors associated with progression to macroalbuminuria in microalbuminuric type 1 diabetic patients: the EURODIAB prospective complications study. *Diabetologia.* 2004;47:1020–8.
- Gnudi L, Karalliedde J. Beat it early. Putative renoprotective hemodynamic effects of oral hypoglycemic agents. *Nephrol Dial Transplant.* 2016;31:1036–43.
- Groop PH, Cooper ME, Perkovic V, et al. Dipeptidyl peptidase-4 inhibition with linagliptin and effects on hyperglycaemia and albuminuria in patients with type 2 diabetes and renal dysfunction: rationale and design of the MARLINA-T2D™ trial. *Diab Vasc Dis Res.* 2015;12(6):455–62.
- Haller H, Ito S, Izzo JL, et al. Olmesartan for the delay or prevention of microalbuminuria in type 2 diabetes. *N Engl J Med.* 2011;364:907–17.
- Hasslacher C, Kulozik F, Lorenzo Bermejo J. Treatment with insulin analogs, especially Glargine and Lispro, associates with better renal function and higher hemoglobin levels in type 1 diabetic patients with impaired kidney function. *Ther Adv Endocrinol Metab.* 2016;7(4):166–77.
- Heart Outcomes Prevention Evaluation (HOPE) Study Investigators. Effects of ramipril on cardiovascular and microvascular outcomes in people with diabetes mellitus: results of the HOPE study and MICRO-HOPE substudy. *Lancet.* 2000;355:253–9.
- Holmes G, Galitz L, Hu P, Lyness W. Pharmacokinetics of insulin aspart in obesity, renal impairment, or hepatic impairment. *Br J Clin Pharmacol.* 2005;60(5):469–76.
- Holstein A, Stumvoll M. Contraindications can damage your health—is metformin a case in point? *Diabetologia.* 2005;48:2454–9.
- Hostetter TH, Troy JL, Brenner BM. Glomerular hemodynamic in experimental diabetes mellitus. *Kidney Int.* 1981;19:410–5.
- Howse PM, Chibrikova LN, Twells LK et al. Safety and efficacy of incretin-based therapies in patients with type 2 diabetes mellitus and CKD: a systematic review and Meta-analysis. *Am J Kidney Dis.* 2016. pii: S0272-6386(16)30285-2.
- Hung AM, Rومية CL, Greevy RA, et al. Comparative effectiveness of incident oral antidiabetic drugs on kidney function. *Kidney Int.* 2012;81:698–706.
- Kainz A, Hronsky M, Stel VS, et al. Prediction of prevalence of chronic kidney disease in diabetic patients in countries of the European Union up to 2015. *Nephrol Dial Transpl.* 2015;30:13–118.
- Kidney Disease Outcomes Quality Initiative (KDOQI), KDOQI clinical practice guidelines and clinical practice recommendations for diabetes and chronic kidney disease. *Am J Kidney Dis.* 2007;49(s2):S12–S154.
- Kidney Disease: Improving Global Outcomes (KDIGO) CKD Work Group. KDIGO clinical practice guideline for the evaluation and management of chronic kidney disease. *Kidney Int.* 2013;S3:1–150.
- Kiss I, Arold G, Roepstorff C, Böttcher SG, Klim S, Haahr H. Insulin degludec: pharmacokinetics in patients with renal impairment. *Clin Pharmacokinet.* 2014;53(2):175–83.
- Kohan DE, Fiochetto P, Tang W, List JF. Long-term study of patients with type 2 diabetes and moderate renal impairment shows that dapagliflozin reduces weight and blood pressure but does not improve glycemic control. *Kidney Int.* 2014;85:962–71.
- Kramer H, Toto R, Peshock R, et al. Association between chronic kidney disease and coronary artery calcification: the Dallas heart study. *J Am Soc Nephrol.* 2005;16(2):507–13.



- Kulozik F, Hasslacher C. Insulin requirements in patients with diabetes and declining kidney function: differences between insulin analogues and human insulin? *Ther Adv Endocrinol Metab.* 2013;4(4):113–21.
- Lewis EJ, Hunsicker LG, Bain RP, Rohde RD. For the collaborative study group\*. The effect of angiotensin-converting-enzyme inhibition on diabetic nephropathy. *N Engl J Med.* 1993;329:1456–62.
- Lewis EJ, Hunsicker LG, Clarke WR, et al. Renoprotective effect of the angiotensin-receptor antagonist irbesartan in patients with nephropathy due to type 2 diabetes. *N Engl J Med.* 2001;345:851–60.
- MacIsaac RJ, Panagiotopoulos S, McNeil KJ, et al. Is nonalbuminuric renal insufficiency in type 2 diabetes related to an increase in intrarenal vascular disease? *Diabetes Care.* 2006;29(7):1560–6.
- Marso SP, Daniels GH, Brown-Frandsen K, et al. Liraglutide and cardiovascular outcomes in type 2 diabetes. *N Engl J Med.* 2016a;375(4):311–22.
- Marso SP, McGuire DK, Zinman B, et al. Design of DEVOTE (trial comparing cardiovascular safety of insulin Degludec vs insulin glargine in patients with type 2 diabetes at high risk of cardiovascular events) – DEVOTE 1. *Am Heart J.* 2016b;179:175–83.
- Matsushita K, van der Velde M, Astor BC, et al. Association of estimated glomerular filtration rate and albuminuria with all-cause and cardiovascular mortality in general population cohorts: a collaborative meta-analysis. *Lancet.* 2010;375(9731):2073–81.
- Moen MF, Zhan M, Hsu VD, et al. Frequency of hypoglycemia and its significance in chronic kidney disease. *Clin J Am Soc Nephrol.* 2009;4(6):1121–7.
- Mogensen CE. Microalbuminuria, blood pressure and diabetic renal disease: origin and development of ideas. *Diabetologia.* 1999;42:263–85.
- Molitch ME, Adler AI, Flyvbjerg A, et al. Diabetic kidney disease: a clinical update from kidney disease: improving global outcomes. *Kidney Int.* 2015;87:20–30.
- Moody WE, Edwards NC, Chue CD, et al. Townsend arterial disease in chronic kidney disease. *Heart.* 2013;99(6):365–72.
- Nakano T, Ninomiya T, Sumiyoshi S, et al. Association of kidney function with coronary atherosclerosis and calcification in autopsy samples from Japanese elders: the Hisayama study. *Am J Kidney Dis.* 2010;55(1):21–30.
- Packham DK, Alves TP, Dwyer JP, et al. Relative incidence of ESRD versus cardiovascular mortality in proteinuric type 2 diabetes and nephropathy: results from the DIAMETRIC (Diabetes Mellitus Treatment for Renal Insufficiency Consortium) database. *Am J Kidney Dis.* 2012;59(1):75–83.
- Papadopoulou-Marketou NP, Chrousos GP, Kanaka-Gantenbein C. Diabetic nephropathy in type 1 diabetes: a review of early natural history, pathogenesis and diagnosis. *Diabetes Metab Res Rev.* 2016. [Epub ahead of print].
- Parving H-H, Lehnert H, Brochner-Mortensen J, et al. The effect of irbesartan on the development of diabetic nephropathy in patients with type 2 diabetes. *N Engl J Med.* 2001;345:870–8.
- Parving HH, Brenner BM, McMurray JJV, et al. Cardiorenal end points in a trial of Aliskiren for type 2 diabetes. *N Engl J Med.* 2012;367:2204–13.
- Penno G, Solini A, Bonora E, the Renal Insufficiency And Cardiovascular Events (RIACE) Study Group, et al. Clinical significance of nonalbuminuric renal impairment in type 2 diabetes. *J Hypertens.* 2011;29:1802–9.
- Penno G, Solini A, Zoppini G, Renal Insufficiency And Cardiovascular Events (RIACE) Study Group, et al. Rate and determinants of association between advanced retinopathy and chronic kidney disease in patients with type 2 diabetes: the renal insufficiency and cardiovascular events (RIACE) Italian multicenter study. *Diabetes Care.* 2012;35(11):2317–23.
- Perkins BA, Ficociello LH, Silva KH, et al. Regression of microalbuminuria in type 1 diabetes. *N Engl J Med.* 2003;348:2285–29.
- Perkovic V, Jardine MJ, Neal B, Bompoint S, Heerspink HJL, Charytan DM, et al. CREDENCE Trial Investigators. Canagliflozin and Renal Outcomes in Type 2 Diabetes and Nephropathy. *N Engl J Med.* 2019;380(24):2295–2306. <https://doi.org/10.1056/NEJMoa1811744>

- Ragot S, Saulnier PJ, Velho G, Gand E, et al. Dynamic changes in renal function are associated with major cardiovascular events in patients with type 2 diabetes. *Diabetes Care*. 2016;39(7):1259–66.
- Retnakaran R, Cull CA, Thorne KI, Adler AI, Holman RR, the UKPDS Study Group. Risk factors for renal dysfunction in type 2 diabetes: U.K. prospective diabetes study 74. *Diabetes*. 2006;55:1832–9.
- Roumie CL, Hung AM, Greevy RA, et al. Comparative effectiveness of sulfonylurea and metformin monotherapy on cardiovascular events in type 2 diabetes mellitus: a cohort study. *Ann Intern Med*. 2012;157:601–10.
- Ruggenenti P, Fassi A, Ilieva AP, et al. Preventing microalbuminuria in type 2 diabetes. *N Engl J Med*. 2004;351:1941–51.
- Ruggenenti P, Porrini EL, Gaspari F, et al. Glomerular hyperfiltration and renal disease progression in type 2 diabetes. *Diabetes Care*. 2012;35:2061–8.
- Scherthauer G, Mogensen CE, Scherthauer GH. The effects of GLP-1 analogues, DPP-4 inhibitors and SGLT2 inhibitors on the renal system. *Diab Vasc Dis Res*. 2014;11(5):306–23.
- Shilpak M. Diabetic nephropathy: preventing progression. *BMJ*. 2010.
- Snyder RW, Berns JS. Use of insulin and oral hypoglycemic medications in patients with diabetes mellitus and advanced kidney disease. *Semin Dial*. 2004;17(5):365–70.
- Solini A, Penno G, Bonora E, Renal Insufficiency And Cardiovascular Events (RIACE) Study Group, et al. Diverging association of reduced glomerular filtration rate and albuminuria with coronary and noncoronary events in patients with type 2 diabetes: the renal insufficiency and cardiovascular events (RIACE) Italian multicenter study. *Diabetes Care*. 2012;35(1):143–9.
- Solini A, Zoppini G, Orsi E, et al. Renal insufficiency and cardiovascular events (RIACE) study group. Resistant hypertension in patients with type 2 diabetes: clinical correlates and association with complications. *J Hypertens*. 2014;32(12):2401–10.
- Steinke JM, Sinaiko AR, Kramer MS, et al. The early natural history of nephropathy in type 1 diabetes. III. Predictors of 5-year urinary albumin excretion rate patterns in initially normoalbuminuric patients. *Diabetes*. 2005;54:2164–71.
- Tabaei BP, Al-Kassab AS, Ilag LL, et al. Does microalbuminuria predict diabetic nephropathy? *Diabetes Care*. 2001;24:1560–6.
- Tanaka T, Higashijima Y, Wada T, et al. The potential for renoprotection with incretin-based drugs. *Kidney Int*. 2014;86(4):701–11.
- The 2016 USA Annual Renal data System. <https://www.usrds.org/adr.aspx>
- The Diabetes Control and Complications Trial Research Group. The effect of intensive treatment of diabetes on the development and progression of long-term complications in insulin-dependent diabetes mellitus. *N Engl J Med*. 1993;329:977–86.
- Tonelli M, Muntner P, Lloyd A, Alberta Kidney Disease Network, et al. Risk of coronary events in people with chronic kidney disease compared with those with diabetes: a population-level cohort study. *Lancet*. 2012;380(9844):807–14.
- UK Prospective Diabetes Study (UKPDS) Group. Intensive blood-glucose control with sulphonylureas or insulin compared with conventional treatment and risk of complications in patients with type 2 diabetes (UKPDS 33). *Lancet*. 1998;352:837–53.
- Urata H, Mori K, Emoto M, et al. Advantage of insulin glulisine over regular insulin in patients with type 2 diabetes and severe renal insufficiency. *J Ren Nutr*. 2015;25(2):129–34.
- Wanner C, Inzucchi SE, Lachin JM, et al. Empagliflozin and progression of kidney disease in type 2 diabetes. *N Engl J Med*. 2016;375:1799–800.
- Yale JF, Bakris G, Cariou B, et al. DIA3004 study group. Efficacy and safety of canagliflozin over 52 weeks in patients with type 2 diabetes mellitus and chronic kidney disease. *Diabetes Obes Metab*. 2014;16:1016–27.
- Zatz R, Dunn BR, Meyer TW, Anderson S, Rennke HG, Brenner BM. Prevention of diabetic glomerulopathy by pharmacological amelioration of glomerular capillary hypertension. *J Clin Invest*. 1986;77:1925–30.

- Zelniker TA, Wiviott SD, Raz I, Im K, Goodrich EL, Bonaca MP, et al. SGLT2 inhibitors for primary and secondary prevention of cardiovascular and renal outcomes in type 2 diabetes: a systematic review and meta-analysis of cardiovascular outcome trials. *Lancet*. 2019;393(10166):31–39. [https://doi.org/10.1016/S0140-6736\(18\)32590-X](https://doi.org/10.1016/S0140-6736(18)32590-X)
- Zoungas S, Chalmers J, Neal B, ADVANCE- ON Collaborative Group, et al. Follow-up of blood-pressure lowering and glucose control in type 2 diabetes. *N Engl J Med*. 2014;371:1392–406.



# Diabetes and the Eye

# 8

Massimo Porta and José Cunha-Vaz

## Contents

Introduction .....	232
Eye Involvements in Diabetes .....	232
Diabetic Retinopathy .....	235
Epidemiology and Risk Factors .....	235
Natural History and Classification of Diabetic Retinopathy .....	236
Pathogenesis .....	237
Clinical Assessment of Diabetic Retinopathy .....	238
Current Options for Medical Treatment .....	249
New Perspectives for Medical Treatment .....	252
Ophthalmological Treatment .....	253
Review of Approaches for the Treatment of Diabetic Macular Edema .....	257
Role of Early Screening for Diabetic Retinopathy in Patients with Diabetes Mellitus .....	259
Conclusions .....	262
References .....	263

## Abstract

Diabetic retinopathy (DR) remains a leading cause of visual impairment in the industrialized world and a growing concern in developing countries, as diabetes is rapidly expanding worldwide. It is classified as nonproliferative (mild, moderate, or severe) and proliferative, with diabetic macular edema potentially developing at either stage. The prevalence and incidence of DR increase with diabetes duration and worsening of glycemic and blood pressure control. Current

---

M. Porta (✉)

Diabetic Retinopathy Centre, Department of Medical Sciences, University of Turin, Turin, Italy  
e-mail: [massimo.porta@unito.it](mailto:massimo.porta@unito.it)

J. Cunha-Vaz

Association for Innovation and Biomedical Research on Light and Image (AIBILI) and University of Coimbra, Coimbra, Portugal  
e-mail: [cunhavaz@aibili.pt](mailto:cunhavaz@aibili.pt)

approaches to prevent DR include optimized control of blood glucose and blood pressure and screening for early identification of high-risk, though still asymptomatic, retinal lesions. Results from clinical trials suggest a role for renin-angiotensin system blockers and fenofibrate in reducing progression and/or inducing regression of mild to moderate nonproliferative DR. Laser photocoagulation remains the mainstay of treatment for proliferative DR and for non-center-involved diabetic macular edema, whereas intravitreal administration of anti-vascular endothelial growth factor (VEGF) agents was shown to improve vision in center-involved macular edema and may become an option also for proliferative DR.

---

**Keywords**

Diabetes mellitus · Diabetic retinopathy · Glycemic control · Serum lipids · Retinal photocoagulation · Vascular endothelial growth factor

---

## Introduction

Manifestations of diabetes can be found in all ocular structures as summarized in Table 1. Some of these are relatively benign, yet characteristic of diabetes, such as corneal wrinkles and iris vacuolation. Other manifestations have more serious effects on ocular function, such as diabetic retinopathy (DR).

## Eye Involvements in Diabetes

### Orbit

Acute orbital cellulitis may occur in diabetes as a result of their general susceptibility to infections.

Orbital mucormycosis is a fulminant mycotic infection involving the nose, paranasal sinuses, orbit, and central nervous system. The reported mortality rate is over 80%; therefore, prompt recognition of the infection is urgent if patients are to survive. Pathologically, the most characteristic lesion of this infection is a thrombosing arteritis that results from direct invasion of the vessel wall by the fungus. This may be contrasted with bacterial involvement of the vascular system, which predominantly affects the veins (Gass 1961). Such thrombosing arteritis produces widespread ischemic necrosis affecting the nose, sinuses, eye, orbit, and brain (Table 1).

### Nerves: Extraocular Muscles

Neuropathy with resultant paralysis of the third, fourth, or sixth cranial nerves as a complication of diabetes was first described in 1866 by Ogle (1866). Waite and Beetham (1935) found the sixth cranial nerve most frequently involved, while other reports have indicated that the third nerve is also commonly affected (Leopold and Mosier 1978).

**Table 1** Ocular manifestations of diabetes

Location	Manifestation	Ref.
Orbit	Cellulitis, mucormycosis	(Gass 1961)
Nerves, extraocular muscles	Diabetic neuropathy	(Goldstein and Cogan 1960)
Ocular appendages	Blepharitis, xanthelasma	(Waite and Beetham 1935)
	Abnormalities of conjunctival vasculature	(Ditzel et al. 1958)
	Elevated tear glucose (glycolacria)	(Gasset et al. 1968)
Cornea	Corneal wrinkles	(Waite and Beetham 1935)
	Corneal pigmentation	(Waite and Beetham 1935)
	Decreased corneal sensitivity	(Scullica and Proto 1965)
Iris, trabecular meshwork	Iris vacuolation	(Smith and Glickman 1975)
	Pigment dispersion	(Armaly and Baloglou 1967)
	Ectropion uveae	(Armaly and Baloglou 1967)
	Chronic simple glaucoma	(Becker 1971)
	Iris neovascularization and glaucoma	(Simmons et al. 1977; Madsen 1971; Little et al. 1976)
Ciliary body	Weakness of accommodation	(Waite and Beetham 1935)
	Basement membrane thickening	(Yamashita and Becker 1961)
Pupil	Sluggish responses	(Waite and Beetham 1935)
	Small pupil	(Gundersen 1974)
	Argyll Robertson pupil	(Waite and Beetham 1935; Gundersen 1974)
	Oculomotor neuropathy with pupillary involvement	(Goldstein and Cogan 1960)
Lens	Senile cataract	(Waite and Beetham 1935; Caird et al. 1964)
	Juvenile cataract	(Waite and Beetham 1935; Caird et al. 1964)
	Transient opacifications	(Corrall 1975; Epstein 1976)
	Fluctuations in refraction	(Waite and Beetham 1935)
Optic nerve	Optic atrophy	(Waite and Beetham 1935)
	Optic neuropathy	(Lubow and Makley 1971; Appen et al. 1980)
	Congenital syndrome with optic atrophy	(Wolfram 1938; Gupta et al. 1979)
Vitreous	Sequelae of diabetic retinopathy	(L'Esperance 1981)
	Increased incidence of asteroid hyalosis	(Hatfield et al. 1962; Smith 1965)
Retina	Diabetic retinopathy	(L'Esperance 1981)
	Increased incidence of vein occlusions	(Ditzel and White 1956)
	Lipemia retinalis	(Laws and Harpur 1958)

Diabetic ophthalmoplegia is otherwise benign, resolving spontaneously in most cases within a few months.

### **Ocular Appendages**

Blepharitis and xanthelasmata were reported to occur significantly more frequently among a large series of diabetics compared with nondiabetic controls (Waite and Beetham 1935).

### **Cornea**

In 1935, Waite and Beetham (1935) first described wrinkling in Descemet's membrane in diabetic individuals.

Henkind and Wise (1961) noted a similar incidence of wrinkles among 133 diabetics. Female diabetics and diabetics with some degree of retinopathy showed a greater frequency of wrinkles.

Decreased corneal sensitivity among diabetics has been reported by Scullica and Proto (1965), Schwartz (1974), and Daubs (1975). Such decreased sensitivity is supposedly a result of diabetic polyneuropathy that affects the trigeminal nerve.

### **Iris: Trabecular Meshwork**

Vacuolation of the pigment epithelium of the iris, the material within diabetic iris vacuoles, has been shown both histochemically (Yamashita and Becker) and by electron microscopy (Yanoff et al. 1970) to be glycogen.

Becker (1971) has summarized the several associations between diabetes and chronic simple glaucoma. Compared with nondiabetics, diabetics have a higher incidence not only of glaucoma but glaucoma-related findings.

These observations suggest that diabetes should be carefully followed for glaucoma, and, conversely, chronic simple glaucoma patients should be screened for diabetes. A diabetic with chronic simple glaucoma may require rigid control of his intraocular pressure.

Neovascular glaucoma often, but not invariably, supervenes in patients who have developed iris neovascularization, with a poor prognosis for both comfort and vision. Since neovascular glaucoma tends to occur in eyes already severely damaged by advanced retinopathy, treatment for the conditions has heretofore been mostly palliative.

Little et al. (1976) have reported that panretinal photocoagulation causes regression of iris and angle neovascularization, presumably by diminishing retinal hypoxia (and theoretical vasoformative factor) inciting the neovascularization.

### **Ciliary Body**

After corneal wrinkles, previously discussed, Waite and Beetham (1935) noted weakness of accommodation to be the second most frequent finding among their observed series of diabetics.

### **Pupil**

Pupillary abnormalities found by Waite and Beetham (1935) among diabetes included poor reaction to topical mydriatics, sluggish response to various stimuli, and typical Argyll Robertson pupils.

It has been suggested that diabetic autonomic neuropathy predominantly affects sympathetic over parasympathetic pupillary innervation, which may explain some of the pupillary abnormalities observed among diabetics (Hreidarsson 1979).

### **Lens**

Rollo, in 1798, first implied an association between diabetes and cataract formation (Waite and Beetham 1935), a concept that was amplified in the bolder literature under the general term diabetic cataract. This term is probably not justified, as the vast majority of lens opacities seen in diabetes are identical to various senile lens changes that occur in nondiabetics (Waite and Beetham 1935; Morse 1976; Leopold and Mosier 1978).

Recent reports have indicated that diabetic patients may develop cataracts more frequently and at earlier ages than nondiabetic ones (Caird et al. 1964; Morse 1976; Leopold and Mosier 1978; Kreines and Rowe 1979).

### **Optic Nerve**

Typical ischemic optic neuropathy can occur in diabetes, usually middle-aged or older adults. The condition is of abrupt onset and is usually monocular, with nerve fiber bundle or altitudinal visual field defects and significant visual loss that generally do not improve.

Bilateral optic atrophy may occur in juvenile diabetics as part of a recessively inherited syndrome, first described in 1938 by Wolfram (1938). The complete syndrome includes juvenile diabetes mellitus, optic atrophy, neurosensory hearing loss, and various manifestations of hypothalamic dysfunction such as diabetes insipidus, disordered temperature regulation, vasomotor instability, and hypogonadism (Gupta et al. 1979).

---

## **Diabetic Retinopathy**

### **Epidemiology and Risk Factors**

Despite improvements in diabetes care and visual outcomes, diabetic retinopathy (DR) remains the fifth leading cause of blindness and visual impairment (Bourne et al. 2014), and the second commonest cause in working age (Liew et al. 2014), in developed countries and can reach its more advanced stages in the almost total absence of symptoms. According to historic series, DR prevalence is about 70% in patients with type 1 diabetes and 40% among those with type 2, with no difference by gender. The prevalence increases with disease duration, and more than 90% of patients with type 1 diabetes develop DR, proliferative in almost half the cases, within 20 years of the diagnosis (Klein et al. 1984b).

A recent pooled analysis on worldwide data concluded that, over a total of 35 studies conducted in 1980–2008 on 22,896 individuals with diabetes, the overall prevalence of any DR was 34.6%, with 6.96% for proliferative DR, 6.81% for diabetic macular edema, and 10.2% for sight-threatening DR from either or both.



Prevalence increased with diabetes duration, HbA1c, and blood pressure levels and was higher in type 1 compared with type 2 diabetes (Yau et al. 2012).

More recent series based upon population screening results report prevalence of any DR and sight-threatening DR of 56.0% and 11.2% in type 1 diabetes, respectively, and 30.3% and 2.9%, in type 2 diabetes, respectively, in Wales 2005–2009 (Thomas et al. 2015), and in 2000–2013 a prevalence of 20.12% for any DR in Germany, with HbA1c and micro- and macroalbuminuria representing the strongest risk predictors for severe DR (Hammes et al. 2015). There are no clear ethnic differences in the relationship between HbA1c and DR (Bower et al. 2013).

## Natural History and Classification of Diabetic Retinopathy

Alterations of retinal capillaries are at the basis of clinically detectable DR and include multiple occlusions, increased permeability of the vessel wall, and, in the proliferative form, growth of newly formed vessels. Occlusions cause areas of ischemia and focal (*microaneurysms*) or generalized dilatation of the capillaries. Dilated, fragile, and hyperpermeable vessels result in *microhemorrhages*, larger *hemorrhages*, and leakage of plasma and lipoproteins in the neuroretina, causing *edema* and the so-called hard exudates. Occlusion of vessels may result in focal retinal ischemia, manifested as white-grayish areas with blurred margins or *cotton wool spots*. The presence of these lesions defines nonproliferative retinopathy, which can be mild, moderate, or severe and further develop into two forms at high risk of visual loss: diabetic macular edema (DME) and proliferative retinopathy (PDR) (Porta and Bandello 2002).

When the lesions of DR involve the macula lutea, the portion of retina responsible for vision of colors and details, severe functional impairment may result. DME affects primarily, but not exclusively, patients with type 2 diabetes, and as these represent more than 90% of the diabetic population, it is now the main cause of visual impairment in diabetes. Progressive ischemia of the peripheral retina leads to PDR, with growth of *new vessels* which may invade the vitreous and give rise to *vitreous hemorrhages* and development of *fibro-glial tissue*. If the latter contracts, retinal detachment may occur. Severe ischemia may proceed to the anterior chamber with development of iris neovascularization (*rubeosis iridis*), causing terminal evolution in *neovascular glaucoma*.

Although DR is considered predominantly a pathology of microvessels, increasing evidence points at degeneration of the neuroretina (mainly apoptosis of ganglion cells and glial activation) as an early event which may predate and perhaps contribute to microcirculatory abnormalities (Antonetti et al. 2006; Garcia-Ramírez et al. 2009). Damage of the neuroretina may result in loss of color discrimination and contrast sensitivity, detectable by electrophysiological studies in patients with no clinically evident DR (Shirao and Kawasaki 1998), and delayed multifocal electroretinographic implicit time may predict the development of early microangiopathy (Fletcher et al. 2007). Metabolic and signaling pathways involved in

retinal neurodegeneration may be shared with, and/or activate mechanisms involved in, the pathogenesis of microangiopathy (Asnaghi et al. 2003).

## Pathogenesis

Among the possible mechanisms of glucose-induced vascular damage, four hypotheses have been widely entertained: (1) increased flux through the polyol pathway, (2) increased formation of advanced glycation end products (AGE), (3) protein kinase C (PKC) activation, and (4) increased flux through the hexosamine pathway.

Aldose reductase (AR) is the key enzyme of polyol pathway. It normally reduces toxic aldehydes to inactive alcohols and excess intracellular glucose to sorbitol while consuming NADPH with consequent hyperglycemic pseudohypoxia (Williamson et al. 1993; Asnaghi et al. 2003) and increased susceptibility to intracellular oxidative stress (Brownlee 2001).

Intracellular high glucose reacts with proteins, amino acids, and nucleic acids via Schiff base condensation with amino groups, followed by irreversible rearrangement into Amadori products. Further Maillard reactions slowly produce AGE, which can also derive from earlier glycation products through glycoxidation or reactive dicarbonyl fragments generated from free glucose. AGE, in turn, can modify intracellular proteins (Giardino et al. 1994), extracellular matrix (Charonis et al. 1990), and circulating proteins, leading to activation of AGE receptors and production of inflammatory cytokines and growth factors.

Intracellular high glucose increases the de novo synthesis of the lipid second messenger diacylglycerol, which in turn activates PKC synthesis, causing a number of effects, such as decreased synthesis of endothelial nitric oxide synthase and increased synthesis of endothelin-1, transforming growth factor  $\beta$ , plasminogen activator inhibitor-1, and NF- $\kappa$ B (Koya and King 1998).

Excess fructose-6-phosphate derived from high availability of intracellular glucose can be transformed into glucosamine-6-phosphate and then to UDP *N*-acetylglucosamine, which acts on serine and threonine residues of transcription factors, resulting in pathological changes in gene expression (Du et al. 2000).

Brownlee and associates have hypothesized that the possible common denominator (“unifying mechanism”) of these apparently independent biochemical pathways is high glucose-induced excess production of reactive oxygen species (ROS) by the mitochondrial electron transport chain inside the endothelium, as a result of increased flux through the Krebs cycle (Nishikawa et al. 2000; Brownlee 2001). ROS, by causing strand breaks in nuclear DNA, activate poly (ADP-ribose) polymerase (PARP) which in turn inhibit glyceraldehyde 3-phosphate dehydrogenase (GAPDH) activity (UK Prospective Diabetes Study (UKPDS) Group 1998b), therefore pushing metabolites from glycolysis in the upstream pathways mentioned above.

Thiamine (vitamin B<sub>1</sub>) and benfotiamine, a thiamine derivative which can be administered orally, block all the above pathways implicated in the pathogenesis of DR and have been shown effective in preventing experimental DR in animals

(Beltramo et al. 2008). However, clinical trials demonstrating its effectiveness are still lacking.

## **Clinical Assessment of Diabetic Retinopathy**

Early detection of diabetic retinopathy and characterization of disease progression in the initial stages of the retinopathy are priorities. It is fundamental to be able to follow the initial stages of the retinopathy, when the retinal alterations may still be reversible and may, therefore, be controlled by medical therapy and adequate metabolic control.

The predominant causes of vision loss in diabetic retinopathy are advanced macular edema and proliferative diabetic retinopathy, both identified as sight-threatening complications of the retinopathy. Visual acuity examination is, therefore, not an appropriate method to follow the initial stages of diabetic retinopathy, and it must be kept in mind that vision loss due to diabetic retinopathy is a sure indication that the retinopathy has already reached an advanced stage.

## **Fundus Photography**

Color fundus photography is the tool more generally used to document retinal disease and its evolution in diabetic patients. It is used for tracking disease progression and is accepted as the best screening method for diabetic retinopathy.

Fundus photographs allow to identify microaneurysms, the most characteristic initial lesions of diabetic retinopathy. They also show the development of hemorrhages and hard and soft exudates and, finally, show well the major changes occurring in the retinal venules and arterioles as the disease progresses (Klein et al. 1985).

Fundus photographs or fundus digital images must be produced in a consistent manner following well-defined protocols, in order to allow comparisons between different examinations performed on different occasions.

Because much of the diabetic clinically significant retinal pathology occurs around the disc and macula, a standard for photographic composition has evolved, with a central 30–40° field identified as field 2 of the ETDRS protocol that includes the entire macula, the entire optic disc, and the major vascular arcades recorded in one view (Fig. 1).

## **Grading Diabetic Retinopathy from Color Fundus Photographs**

Fundus photography has been the method of choice to follow diabetic retinopathy, because (1) it is noninvasive, technically easy, and well accepted by patients and (2) its usefulness has been demonstrated in a large-scale randomized clinical trial, the Diabetic Retinopathy Study (DRS), which showed the benefits of photocoagulation in the treatment of proliferative diabetic retinopathy.

Fundus photography was chosen to monitor retinopathy in the Diabetes Control and Complications Trial in the USA and UK Prospective Diabetes Study Trial. Elaborate fundus photography grading was developed from the original Airlie

**Fig. 1** Photography of central field 2 showing the entire macula, the entire optic disc, and the major vascular arcades

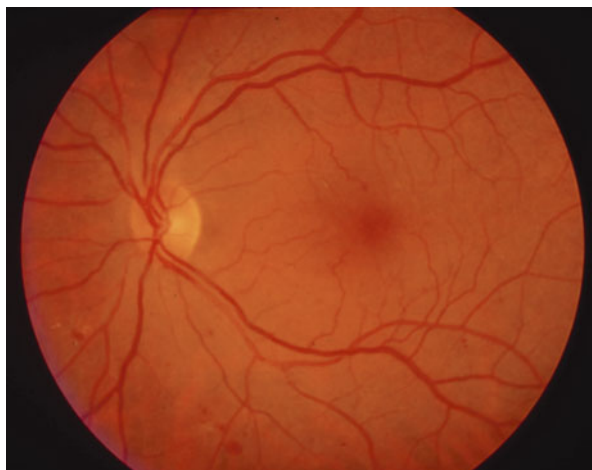

House Diabetic Retinopathy Classification to document progression and delineate the natural history of retinal disease, from the earliest visible alterations to more advanced stages, e.g., maculopathy and high-risk proliferative diabetic retinopathy.

These gradings, however, offer little information on the initial stages of the disease. Microaneurysms need to be counted to assess progression of retinopathy, and new microaneurysms should always be added to those previously identified in the same retina (Torrent–Solans et al. 2004).

### **Monitoring the Initial Stages of Diabetic Retinopathy Progression: Microaneurysm Turnover**

It is of fundamental importance to monitor the progression of the disease in a specific patient and identify if he/she is a “progressor,” i.e., a patient that shows signs of rapid progression. Some eyes/patients need special attention and timely intervention to avoid development of sight-threatening diabetic retinopathy complications, macular edema, or proliferative diabetic retinopathy.

The initial alterations that occur in nonproliferative diabetic retinopathy and need to be monitored are microaneurysm dynamics (their formation and disappearance) and vascular leakage with subsequent edema and hard exudate formation.

Visual function loss occurs characteristically late in diabetic retinopathy, because the eye has a large functional reserve of vision and diabetic retinopathy affects initially the inner layers of the retina away from the photoreceptors. Therefore, structural changes are detected in diabetic retinopathy earlier than functional changes. We have, therefore, to focus on evidence of structural changes if we want to follow progression in the earliest stages of diabetic retinopathy.

To identify progression it is essential to collect sequential series of images, and these images must be compared. The need for co-registration of these sequences of images is, therefore, of great relevance. By applying novel image co-registration comparative analysis software, it is now possible to perform reliable sequential comparisons of fundus digital photography images (Nunes et al. 2009).

Softwares are available to automatically detect changes occurring in eye fundus digital images, by comparing successive visits to the reference image, in each eye, based on co-registration and co-localization of the changes (Figs. 2 and 3).

On fundus photography, microaneurysms and small hemorrhages are the initial changes detected in the diabetic retina. They may be counted, and retinal microaneurysm counting has been previously suggested as an appropriate marker of retinopathy progression (Klein et al. 1995; Csaky et al. 2008).



**Fig. 2** This figure illustrates the automatic microaneurysm tracking over time, color-coding each detected microaneurysm as new, old, or disappeared (based on proprietary co-registration algorithm)



**Fig. 3** The software automatically calculates microaneurysm formation and disappearance rates. The patient above had a microaneurysm formation rate of five microaneurysms/year over a 24-month follow-up

Retinal microaneurysms are relevant lesions of diabetic retinopathy, and even one or two microaneurysms in an eye should not be regarded as unimportant (Klein et al. 1989; Kohner et al. 1999). More recently, Sjølie et al. (2011) confirmed that microaneurysm counts were predictive of an increased risk of retinopathy progression.

Our studies have shown that it is not the absolute total number of microaneurysms at a certain point in time that may provide the best indication of retinopathy progression, but the rate of microaneurysm turnover in successive visits during a 1- or 2-year period.

### **Wide Field Fundus Angiography**

Currently, ultra-wide field (UWF) fluorescein angiography (FA) devices allow capture of a single high-resolution 200° retinal field covering more than 80% of the retinal surface where all vessels are in the same angiographic phase.

The nonperfusion identified on UWF FA in diabetic eyes with DR was located primarily in the midperipheral retina and pressed posteriorly with increasing severity.

Peripheral nonperfusion likely underlies the development of predominantly peripheral lesions (PPLs) and accounts for the marked increases in retinopathy progression associated with the presence of PPLs (Silva et al. 2016).

### **Fluorescein Angiography**

Since 1961, when Novotny and Alvis introduced the technique of fluorescein angiography, its routine use has contributed much to our present understanding of diabetic retinal disease.

Sodium fluorescein, which is approximately 80% protein-bound to albumin, is the dye used in fluorescein angiography. Fluorescein is a small molecule that remains unbound in 10–20% of the amount injected and therefore diffuses freely through the choriocapillaris, Bruch's membrane, optic nerve, and sclera. However, its diffusion through the tight junctions of the retinal endothelial cells and of the retinal pigment epithelium which are the inner and outer blood-retinal barriers is minimal (Shakib and Cunha-Vaz 1966). If there is a disruption of the blood-retinal barrier, dye leakage occurs. Similarly, the tight junctions (zonula occludens) between the retinal pigment epithelial cells constitute the outer blood-retinal barrier, which under normal, physiological conditions does not allow visible leakage of fluorescein from the choroid into the retina.

Another fundamental contribution of fluorescein angiography to our understanding of diabetic retinopathy is the identification of areas of capillary closure or capillary dropout (Fig. 4).

The normal regular distribution of the capillary network appears interrupted by areas which are not perfused by the dye, identifying well areas outlined by perfused capillaries (Kohner and Henkind 1970).

Fluorescein angiography, because of the need for intravenous injection of fluorescein, is used much less frequently than fundus photography. Although sodium fluorescein is generally safe and is used in the daily routine of every

**Fig. 4** Diabetic retinopathy. Fluorescein angiography showing multiple microaneurysms and a few areas of capillary closure



ophthalmological care center, severe anaphylactic reactions may occur sporadically (1 in 200,000) (Yannuzzi et al. 1986).

In 1975, vitreous fluorometry, a clinical quantitative method for the study of the blood-retinal barrier, was introduced by our group (Cunha-Vaz et al. 1975), showing that an alteration of the blood-retinal barrier could be detected and measured in diabetic eyes apparently with normal fundi. The disturbance of the blood-retinal barrier, as evidenced by vitreous fluorometry, appeared in some patients before microaneurysms or capillary closure could be demonstrated by fluorescein angiography. These results were confirmed by Waltman et al. (1978a, b).

One major limitation of the available commercial instrumentation for vitreous fluorometry (Fluorotron Master Coherent, USA) was associated with the fact that the permeability of the blood-retinal barrier is measured as an average over the macular area. Accurate mapping of localized changes in the permeability of the blood-retinal barrier would be beneficial for early diagnosis, to explain the natural history of retinal disease and to predict its effect on visual acuity.

### **Optical Coherence Tomography (OCT)**

Recently, one methodology capable of measuring objective changes in retinal thickness and giving morphological and topographic images of the retina became available, optical coherence tomography (OCT), changing dramatically the landscape of diabetic macular edema diagnostic and follow-up.

OCT is a noninvasive and noncontact diagnostic method, well tolerated by patients, that provides important information about the retina. OCT imaging is analogous to B-scan ultrasound imaging, except that it uses infrared light reflections instead of ultrasound. It produces reliable, reproducible, and objective cross-sectional images of the retinal structures and the vitreoretinal interface and allows quantitative measurements of retinal thickness.

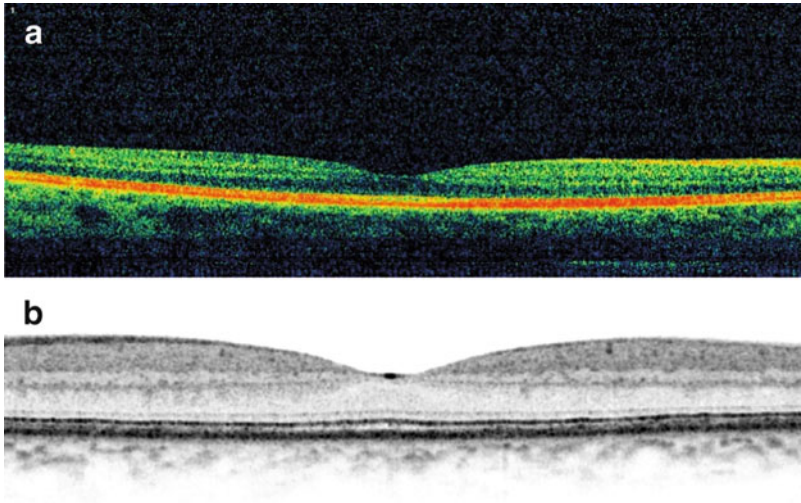

**Fig. 5** SD-OCT normal cross-sectional macular image. (a) False color. (b) Grayscale

OCT brought new insights about morphological changes of the retina in diabetic retinopathy and diabetic macular edema. It showed that macular edema may assume different morphologic patterns (Yamamoto et al. 2001; Kim et al. 2006). In addition, a quantitative characterization of macular edema became feasible, as determined by measurements of retinal thickness and volume. OCT has been demonstrated to be more sensitive than slit-lamp biomicroscopy in detecting small changes in retinal thickness (Hee et al. 1995; Yang et al. 2001; Massin et al. 2006; Lang 2007) and is clearly less subjective. In cases of diabetic macular edema, OCT scans may demonstrate diffuse thickening of the neurosensory retina and loss of the foveal depression; cystic retinal changes, which manifest as areas of low intraretinal reflectivity; and serous retinal detachment, alone or combined.

Cross-sectional images resemble closely the histological appearance of the retina (Ron Margolis and Peter K. Kaiser 2008) (Figs. 5 and 6). The top of the image corresponds to the vitreous cavity, which is optically silent, in a normal patient, or may show the posterior hyaloid face, if there is a posterior vitreous detachment (Cunha-Vaz and Coscas 2010). Central foveal depression is visible in normal eyes. The anterior boundary of the retina corresponds to the internal limiting membrane, at the vitreoretinal interface, hyperreflective and well defined, because of the contrast between the nonreflective vitreous and the backscattering of the retina.

The internal structure of the retina has heterogeneous reflections and distinct bands, and an anatomic correlation with the layers of the human retina has been proposed (Drexler 2007) (Fig. 6). Retinal nerve fiber layer is aligned horizontally, demonstrating higher tissue signal strength and appears thicker and closer to the optic nerve as expected. Axially aligned cellular layers – ganglion cell layer, inner nuclear layer, and outer nuclear layer – have lower tissue signal compared with



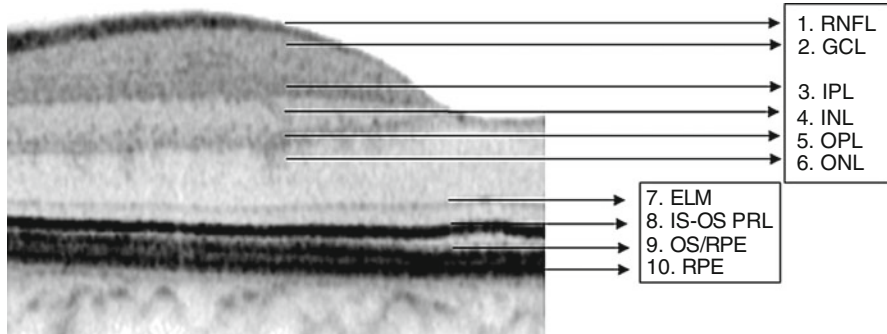

**Fig. 6** Normal cross-sectional macular image (grayscale) and anatomic correlation. (1) *RNFL* retinal nerve fiber layer, (2) *GCL* ganglion cell layer, (3) *IPL* inner plexiform layer, (4) *INL* inner nuclear layer, (5) *OPL* outer plexiform layer, (6) *ONL* outer nuclear layer, (7) *ELM* external limiting membrane, (8) *IS-OS PRL* inner segment-outer segment photoreceptor layer, (9) *OS/RPE junction* outer segment/retinal pigment epithelium, (10) *RPE* retinal pigment epithelium

horizontally aligned layers, internal limiting membrane, retinal nerve fiber layer, and plexiform layers, which have higher tissue signal. Typically, nuclear layers appear hyporeflective, while plexiform layers (inner plexiform layer and outer plexiform layer) and axonal layers are relatively hyperreflective.

In the outer retina, different hyperreflective structures (bands) are visualized. TD Stratus OCT images the outer retinal layers as two hyperreflective bands, the photoreceptor's outer segments (inner) and the retinal pigment epithelium/choriocapillaris complex (outer). On the other hand, SD-OCT scans of the outer retina allow visualization of more bands than the TD-OCT. With this high-resolution technology, three or four distinct strongly reflective bands are apparent, although their histological correlation remains a matter of discussion. According to Pircher et al. (2006), the first (inner) band may correspond to the external limiting membrane and the second to the interface of the inner and outer segments of the photoreceptor layer, the third band may represent the outer segment – retinal pigment epithelium junction – and the fourth (outer) is assumed to represent the retinal pigment epithelium (Fig. 6). The analysis of structural changes in the outer retinal layers, particularly affecting photoreceptors and their interface, is now possible, using SD-OCT (Coscas and Soubrane 2009).

Since the commercialization of OCT systems, several types of software to quantify macular thickness became available. Mean macular retinal thickness is displayed as a two-dimensional false color-coded map, where bright colors (e.g., red and white) represent thick areas and dark colors (e.g., blue and black) represent thin areas, and as a numerical map, for nine ETDRS-type areas (Fig. 7).

Nowadays, OCT is increasingly used in the early detection of subclinical macular edema. Cross-sectional images of the retinal structures and thickness maps provide an objective and reproducible baseline characterization of the retinal disease. OCT imaging seems to be more sensitive than slit-lamp biomicroscopy to detect small changes in retinal thickness (Hee et al. 1995; Yang et al. 2001; Lang 2007) and to

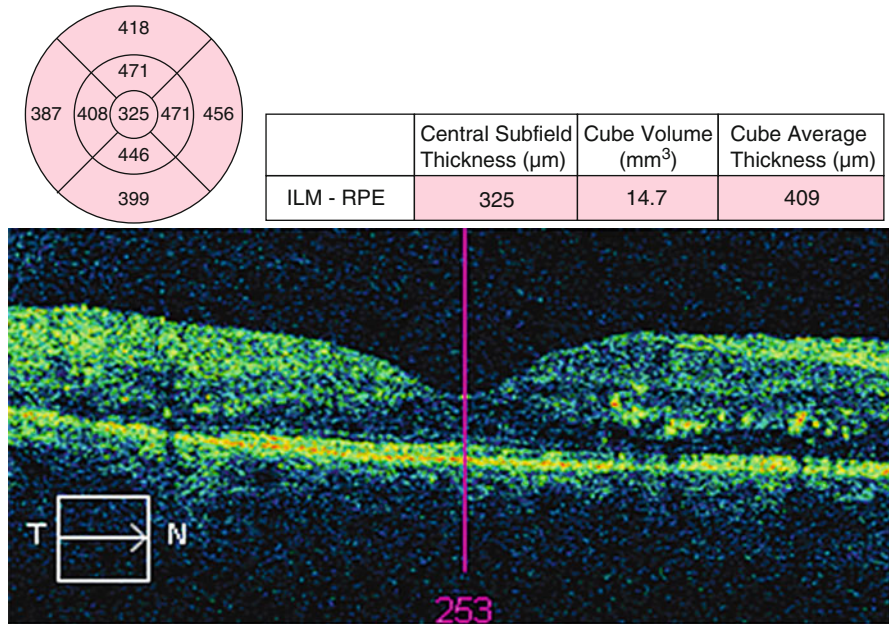

**Fig. 7** Diabetic retina showing increased thickness identifying the presence of retinal edema (OCT examination)

visualize infraclinical foveolar detachments (Massin et al. 2006; Bandello et al. 2015). OCT scans also allow an accurate evaluation of disease progression, over time, and particularly after treatment.

OCT images of diabetic macular edema depict the presence of low intraretinal reflectivity, due to fluid accumulation in the extracellular space of the retina. The process begins as a diffuse retinal thickening with spongelike appearance of the retinal layers, showing increase in the extracellular spaces advancing to the typical image of cystoid spaces (Otani et al. 1999; Alkuraya et al. 2005; Bandello et al. 2015) (Fig. 8).

Another advantage of the OCT is the possibility to analyze the vitreomacular interface. It is possible to determine the status of the posterior hyaloid when it is only slightly detached from the macular surface (Gaucher et al. 2005). The concept of vitreoretinal traction is now considered of major relevance in the OCT classification of diabetic macular edema (Panozzo et al. 2003; Kang et al. 2004).

A composite grading for macular edema based on Fig. 9 and Table 2 has recently been proposed. The mean RT values for the different areas of the OCT grid are considered abnormal if they correspond to the RT values defined by the DRCR.net as subclinical macular edema for the central subfield and if they are  $\geq 2$  SD beyond the normative database for the device used, in the inner and outer rings of the OCT macula grid. The grading includes four characteristics: (1) location of edema (whether the central subfield is involved and which, if any, inner and outer rings

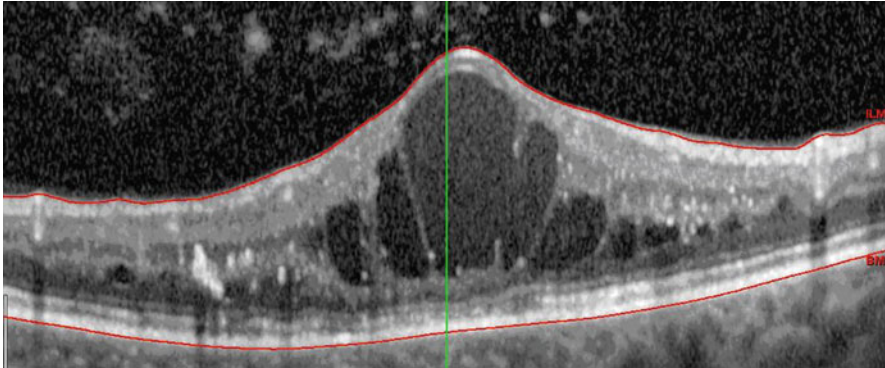

**Fig. 8** Cystoid macular edema (Cunha-Vaz 2014)

**Fig. 9** Central subfield (a) and quadrants of the inner ring (b) and outer ring (c) as represented in OCT displays. Values are considered for the classification if they show (a) RT value corresponding to subclinical macular edema as defined by DRCR.net and (b) and (c) RT values for each quadrant that are above threshold (average normal +2 SD) in two quadrants or only one quadrant with RT value 15  $\mu$ m above threshold (average normal +2 SD)

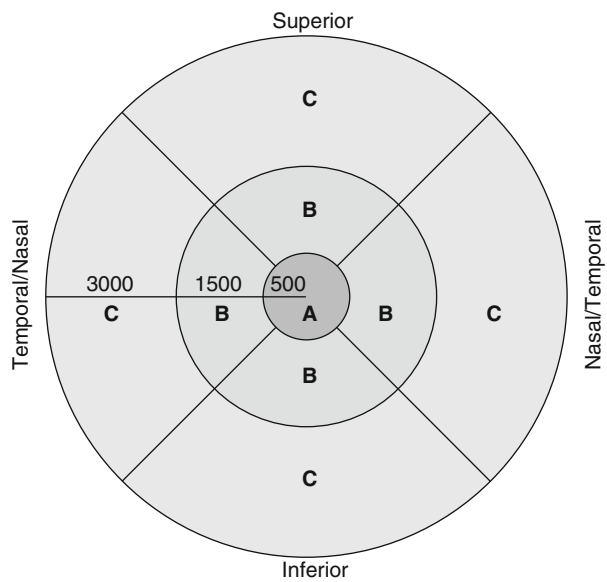

are involved); (2) the amount of edema, represented by the highest absolute mean RT value registered in any of the subfields, i.e., central subfield or any quadrant of the inner and outer OCT rings; (3) the presence or absence of signs of vitreous traction (VT); and (4) the identification of the OCT instrument with which the data was acquired. For example, an eye with increased RT in the central subfield and in two quadrants of inner ring, showing the highest mean RT value of 450  $\mu$ m in one of the inner ring quadrants and no signs of vitreous traction (NVT) using Cirrus SD-OCT, Zeiss, is identified as 10/450  $\mu$ m/NVT/Cirrus SD-OCT. Another eye with an increased RT only in the outer ring, involving three quadrants, showing the highest RT value of 480  $\mu$ m in any of the quadrants involved and no signs of

**Table 2** Location score

Score	Location with increased RT
0	No increases in the central subfield, inner ring or outer ring
1	Increases in outer ring: two quadrants $\geq$ normal mean + 2 SD or one quadrant $\geq$ normal mean + 2 SD + 15 $\mu$ m
2	Increases in outer ring: three or four quadrants $\geq$ normal mean + 2 SD
3	Increases in inner ring: two quadrants $\geq$ normal mean + 2 SD or one quadrant $\geq$ normal mean + 2 SD + 15 $\mu$ m
4	Increases in inner ring: three or four quadrants $\geq$ normal mean + 2 SD
5	Criteria for score 3 plus score 2 or criteria for score 4 plus score 1
6	Criteria for score 4 plus score 2
7	Increase in central subfield: subclinical macular edema (DRCR.net)
8	Criteria for score 7 plus score 1
9	Criteria for score 7 plus score 2
10	Criteria for score 7 plus score 3
11	Criteria for score 7 plus score 4
12	Criteria for score 7 plus score 5
13	Criteria for score 7 plus score 6

vitreous traction with the examination performed in the Spectralis SD-OCT, Heidelberg, would be graded as 2/480  $\mu$ m/NVT/Spectralis SD-OCT.

### OCT Angiography

Optical coherence tomography angiography visualizes vasculature using motion contrast. Optical coherence tomography operates under the basic assumption, which is an oversimplification, that the only moving thing in the retina is blood flow. Pixels from individual areas in repeated OCT images are compared over time, and those pixels which show changes or fluctuations are displayed as bright, whereas pixels from areas with little or no change are displayed as black. There are many different algorithms or methods for detection of motion contrast. Some involve using OCT signal amplitude, phase, or a combination of the two. There are also different statistical techniques for assessing changes. However, all these methods eventually visualize vasculature by detecting motion.

OCT angiography has the advantage that it is able to identify the retinal vasculature without the need for dye injection. Imaging can be performed in situations when conventional angiography is not indicated, repeated on every patient visit, and dynamic changes can be assessed.

The images produced from the retinal vascular network are remarkably similar to those seen in fluorescein angiography, offering more detail. Furthermore, OCT angiography reveals, for the first time, in a clinical environment the deep retinal vascular plexus which is not visualized in fluorescein angiography.

In diabetic retinopathy, OCT angiography is offering new perspectives for quantifying reliably capillary closure, particularly of the changes occurring in the superficial retinal capillary net (Agemy et al. 2015). Neovascularization is also well

demonstrated and identified. Microaneurysms, however, do not correspond well with the ones identified in fluorescein angiography because of the variations in blood flow between different microaneurysms, and a consensus is needed to identify clearly what should be considered a microaneurysm in OCT angiography.

### **Electrophysiological Testing**

Electrophysiological changes in diabetes may have a microvascular origin (Scholl and Zrenner 2000) or be independently due to retinal cell dysfunction (Tzekov and Arden 1999). Despite many psychophysical and electrophysiological methods that have been used to document diabetic retinopathy, a consensus on the ideal tool to detect retinal dysfunction in the initial stages of diabetic retinopathy is still missing.

In this respect, it must be kept in mind that assessment of standard visual acuity is not expected to be very rewarding since visual acuity remains stationary until ~50% of the neuroretinal pathways are affected (Frisén and Frisén 1976) and the foveal avascular zone is frequently enlarged in diabetic patients without any sign of change in visual acuity (Arend et al. 1995). This suggests that psychophysical techniques should aim to assess separately distinct functional channels (Bresnick et al. 1985; Green et al. 1985). Evidence for predominant early involvement of the parvocellular pathway suggests that the physiology of the perifoveal area should be under scrutiny in future studies, since changes in the microvasculature in this region may be predictive of visual outcome.

Diabetic retinopathy is initially focal in its nature, which renders standard electrophysiological methods that measure the global response of retinal photoreceptors, such as the flash electroretinogram (ERG), rather unpromising approaches. For these reasons conflicting reports have emerged in the literature, some describing significant differences (Juen and Kieselbach 1990; Holopigian et al. 1992) and others not (Jenkins and Cartwright 1990). The reduction of the b-wave of the conventional ERG is often reported only for advanced cases, and more sensitive results can only be obtained with the calculation of intensity-response functions, which are of limited clinical applicability.

In a recent study, Jansson et al. (2015) evaluated the role of photopic full-field electroretinopathy and retinal thickness measurements by SD-OCT in the assessment of type 1 diabetic retinopathy. They concluded that it has limited clinical value and that thinning of the central retina leading to significant functional impairment may reflect in the retinal tissue. This process may occur independently of the retinal vascular disease.

There is an ongoing search for measures capable of detecting earlier dysfunction. Recent candidates concerning parametric evaluation have included amplitude and delay of oscillatory potentials, pattern ERG, the scotopic threshold response, and more recently the multifocal ERG.

### **Oscillatory Potentials (OPs)**

Oscillatory potentials are high-frequency retinal electrophysiological responses (100–160 Hz) which are superimposed on the ascending limb of the b-wave (Yonemura et al. 1963; Wachtmeister and Dowling 1978) and seem to be changed

in early stages of diabetic retinal disease. They are a signature of the involvement of inner retinal layers since they are thought to originate in the inner plexiform layer, namely, from inhibitory circuits connecting amacrine and ganglion cells.

Oscillatory potentials are usually taken as good indicators of the extent of retinal ischemia and may be reduced at all stages of diabetic retinopathy, with a good correlation with severity, especially during proliferative stages.

Bresnick and colleagues (Bresnick et al. 1984, 1985; Bresnick and Palta 1987) confirmed and extended these results, by showing that oscillatory potential amplitude predicts progression (independently from predictors taken from fundus photography and fluorescein angiography) of eyes with nonproliferative diabetic retinopathy or mild proliferative diabetic retinopathy to severe proliferative diabetic retinopathy. Eyes with abnormal oscillatory potential amplitudes had a steady rate of progression to severe proliferation (28% after 1 year and 52% after 2 years). Eyes with normal oscillatory potentials had a much lower rate of progression (0% and 7%, respectively).

### **Multifocal Electroretinography**

Multifocal electroretinography (mfERG) (Sutter and Tran 1992) provides functional topographic detail that overcomes the disadvantages of conventional electrophysiology. Objective measurement of retinal dysfunction simultaneously at multiple locations, by means of this technique, is now being increasingly used in diabetes research.

Electrophysiological local amplitude changes and delays have been found in the retinas of diabetic patients with or without retinopathy, both in regional and local averages (Palmowski et al. 1997; Fortune et al. 1999; Scholl and Zrenner 2000; Bearnse et al. 2004).

Multiple prospective analyses of local mfERGs identified functional abnormalities in eyes with diabetic retinopathy, both in retinal regions corresponding to retinopathy and in areas without signs of it (Fortune et al. 1999; Bearnse et al. 2004). In the same line, it has been found that mfERG implicit time delays are associated with retinal locations in which new nonproliferative diabetic retinopathy will develop 1 year later (Han et al. 2004). All these promising results suggest that mfERG may become a pivotal technique for the study of neural impairment in the diabetic retina. Apparently, in some eyes, functional abnormalities of the retina and vision can occur before clinical signs of retinopathy vascular damage are visible on ophthalmoscopy (Fig. 10).

### **Current Options for Medical Treatment**

Current possibilities to prevent and/or treat retinopathy include optimized control of blood glucose and blood pressure and screening for early identification of high-risk, though still asymptomatic, retinopathy.

The Diabetes Control and Complications Trial (DCCT) demonstrated that optimized insulin treatment reduces the incidence of retinopathy by 76%, progression of

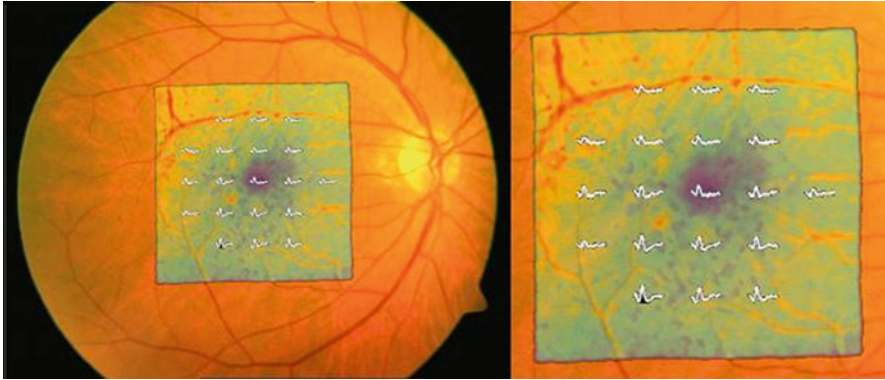

**Fig. 10** Deformable image registration between color fundus photograph (background image), leakage analysis (retinal leakage analyzer) (central squared area), and multifocal electroretinography (mfERG) (curve responses in white)

mild to moderate nonproliferative DR by 54%, and the need for photocoagulation by 56% (The Diabetes Control and Complications Trial Research Group 1993) in patients with type 1 diabetes. In those with type 2 diabetes, the UK Prospective Diabetes Study (UKPDS) showed that, over 12 years, optimized metabolic control reduces progression of DR by 21% and need for cataract surgery in 24% of cases (UK Prospective Diabetes Study (UKPDS) Group 1998a). Follow-up of the patients involved in these studies showed that the benefits of glycemic control carry over in time a sort of metabolic “memory” (The Diabetes Control and Complications Trial/Epidemiology of Diabetes Interventions and Complications (DCCT/EDIC) Research Group 2009) or “legacy” (Holman et al. 2008), so that any period of life spent in good glycemic control is “accounted for” in the later prevention of retinopathy and other complications.

The UKPDS (UK Prospective Diabetes Study (UKPDS) Group 1998b) also showed that reducing blood pressure (from 154/87 to 144/82 mmHg throughout 8 years) reduces the progression of DR by 34% and the overall risk of worsening of visual acuity by 47%, possibly by reducing DME. Until recently, the only intervention study to support a role for intensive hypertension control in the prevention of DR was the UKPDS. However, the ADVANCE (Patel et al. 2007) and ACCORD (Chew et al. 2010) trials could not confirm an influence of blood pressure lowering on progression of DR. Arguably, patients in the UKPDS had larger reductions from higher blood pressure values than those in ADVANCE ( $-5.6$  mmHg systolic and  $-2.2$  diastolic blood pressure from 145/81 mmHg, follow-up 4.3 years) (Patel et al. 2007) or in ACCORD, starting from 135/75 down to 128/68 with a median follow-up of 3.7 years (Chew et al. 2010), suggesting either that blood pressure lowering is more effective in poorly controlled hypertension or that longer follow-up is necessary to observe an effect on DR progression. No legacy effect was observed for blood pressure control in the UKPDS patients (Holman et al. 2008).

Current guidelines recommend to maintain HbA1c below 7.0% and blood pressure below 140/90 or 130/80 for patients at higher cardiovascular risk (Krikorian 2016). However, achieving these targets is far from easy outside of clinical trials in the general diabetic population, and data collected in most countries show that less than half, often less than one third, of patients do stay within those targets. Patients on insulin therapy have worse control than those treated with oral hypoglycemic agents, and, in turn, the latter fare worse than those on diet alone (Gill et al. 2003), presumably reflecting the levels of residual endogenous insulin secretion. Possible reasons for this high level of therapeutic failure include medical inertia, reduced patient adherence to prescriptions, and the inadequacy of current pharmacological options and lifestyle measures (Mannucci et al. 2014).

In any case, the overall outcomes of diabetes care seem to be improving gradually worldwide, thanks to increasing awareness and availability of materials for self-monitoring and therapy. Data from the National Health and Nutrition Examination Survey (NHANES) 1999–2004 show a slow but steady increase in the percentage of US patients with HbA1c less than 7.0% (Ford et al. 2008). Probably in connection with this positive trend, the epidemiological data collected in Scandinavia and Wisconsin show a lower cumulative incidence of proliferative retinopathy in patients who contracted type 1 diabetes in more recent years (Hovind et al. 2003; Klein et al. 2008). In the DCCT/EDIC cohort, in 30 years of follow-up, the cumulative incidence of PDR was 21% in the patients originally randomized to optimized therapy during the DCCT, compared to 50% in those who remained all their life on conventional treatment (The Diabetes Control and Complications Trial/Epidemiology of Diabetes Interventions and Complications (DCCT/EDIC) Research Group 2009).

There are however different approaches to interpreting these data. Progression of DR might be delayed rather than reduced in absolute terms, and the prolongation of life expectancy in patients may result in PDR appearing later rather than never at all. Data extrapolated from the DCCT dataset suggest that optimized insulin treatment would prolong life free of PDR by 14.7 years, of macular edema by 8.2 years, and of blindness by 7.7 years (The Diabetes Control and Complications Trial Research Group 1996), all weighted against a 2–3 times higher risk of severe hypoglycemia and increase in body weight. In addition, other predisposing factors not yet identified may play a role, as suggested by daily clinical experience and also quantified in the DCCT series. In fact, a post hoc analysis of all patients who participated in the trial showed that 10% of those who remained in the lowest HbA1c quintile (<6.87%) still developed DR and 43% of those who remained in the worst quintile (HbA1c >9.49%) did not develop retinal lesions during the study (Zhang et al. 2001). The search for genetic markers that make patients susceptible to, or protected by, microangiopathy remains an open field that has so far produced few generalizable results. Of interest is the recent identification of a point mutation associated with the gene coding for thiamine transporter hTHTR2, the minor allele of which appears to be strongly protective from PDR combined with end-stage diabetic renal disease in a large combined cohort of patients with type 1 diabetes from Finland and Wisconsin (Porta et al. 2015).



## New Perspectives for Medical Treatment

Lack of therapies targeting specific pathogenic mechanisms remains a serious limitation to the prevention of diabetes-related blindness. Experimental evidence suggests involvement of the renin-angiotensin system (RAS) in that a physiologically active RAS is present in the eye, where angiotensin 2 appears to promote retinal expression of VEGF, through AT1 receptors, and endothelial cell proliferation.

The EUCLID study (Chaturvedi et al. 1998) reported that lisinopril, an angiotensin-converting enzyme inhibitor (ACEi), may reduce the progression of DR and the incidence of PDR in patients with type 1 diabetes. However, retinopathy was not a primary outcome of the study, which was also undersized from the statistical power point of view. The more recent ADVANCE/ADREM (Beulens et al. 2009) appeared to show some protective effect, though not statistically significant, on progression of retinopathy of another ACEi, perindopril, associated with indapamide, a diuretic, in 1241 patients with type 2 diabetes. DIRECT (Diabetic Retinopathy Candesartan Trials) was a group of three multicenter, randomized, placebo-controlled studies designed to determine if pharmacological RAS blockade by candesartan 32 mg either prevents onset of DR in patients with type 1 diabetes (DIRECT-Prevent 1) or progression or promotes regression of DR in patients with type 1 (DIRECT-Protect 1) and 2 (DIRECT-Protect 2) diabetes (Chaturvedi et al. 2008; Sjølie et al. 2008). A total of 5231 patients with normoalbuminuria were randomized. The average follow-up was 4.7 years. Prevent-1 showed that candesartan reduces the risk of onset of retinopathy in type 1 diabetes by 35%, with an NNT of 18 patients treated to prevent one event. The severity of retinopathy at the end of the study was significantly more favorable in patients treated with candesartan in Prevent-1, Protect-1 (Chaturvedi et al. 2008), and Protect-2 (Sjølie et al. 2008). The latter study showed a 13% reduction, not statistically significant, in the risk of progression of DR and a highly significant 34% increase in the probability of DR regression in type 2 diabetes, with an NNT of 21 patients treated to achieve an event. The results of DIRECT-Protect 2 represent the first description in the literature of regression of DR induced by a drug. The favorable effect of RAS blockade was confirmed by the RASS study (Mauer et al. 2009), conducted on 285 normotensive patients treated with enalapril 20 mg/day, losartan 100 mg/day, or placebo. Enalapril and losartan reduced the likelihood of DR progression by 65% and 70%, respectively, in patients with type 1 diabetes. Although the results of the previous studies are strongly indicative of a beneficial effect of RAS blockade in the early stages of DR, none of them was sufficient to grant registration for this specific indication. Hence, their use cannot be formally recommended in patients with DR who do not also have hypertension and/or microalbuminuria.

With reference to other possible mechanisms, the FIELD study showed a reduction by approximately 30% in the need for laser treatment for DME and PDR in patients treated with fenofibrate 200 mg/day. The drug prevented progression of existing retinopathy, regardless of its metabolic effects, but was not effective in terms of primary prevention (Keech et al. 2007). Moreover, the retinopathy endpoint was a

tertiary objective, measured in 1012 of 9795 patients enrolled in the study. Another clinical trial, ACCORD (Chew et al. 2010), confirmed reduced progression of DR in patients with type 2 diabetes treated with fenofibrate and statins, compared to patients treated with statins alone. The possible mechanisms for this unexpected action of fenofibrate remain to be elucidated.

Increased tendency to platelet aggregation in diabetes has long been suspected to play a role in determining capillary occlusions which characterize the intermediate stages of nonproliferative DR. Antiplatelet drugs such as aspirin, dipyridamole, and ticlopidine underwent clinical trials in the 1970s and 1980s, demonstrating modest efficacy in slowing the formation of new microaneurysms in early nonproliferative DR (The DAMAD Study Group 1989; The TIMAD Study Group 1990) and no effects on evolution once DR reaches the pre-proliferative and proliferative stages (Early Treatment Diabetic Retinopathy Study Research Group 1991b). Aspirin, however, does not increase the risk of bleeding from new vessels, so that proliferative retinopathy is not a contraindication to its use for other indications (Early Treatment Diabetic Retinopathy Study Research Group 1991b).

## **Ophthalmological Treatment**

### **Laser and Surgical Interventions for Severe Nonproliferative and Proliferative Diabetic Retinopathy**

#### **Panretinal Laser Photocoagulation**

Panretinal laser photocoagulation, in which laser burns are placed over the entire retina, sparing the central macula, is an established technique for treating proliferative diabetic retinopathy.

The strongest evidence comes from two related randomized clinical trials in the 1970s and 1980s, the Diabetic Retinopathy Study (DRS) (Group 1978; The Diabetic Retinopathy Study Research Group 1981) and the ETDRS (Early Treatment Diabetic Retinopathy Study Research Group 1991a). The DRS randomized 1758 patients with proliferative diabetic retinopathy in at least one eye or bilateral severe nonproliferative diabetic retinopathy to receive panretinal laser photocoagulation or no treatment. At 2 years, severe visual loss (visual acuity  $<5/200$  on two successive visits) was observed in 6.4% of treated versus 15.9% of untreated eyes, with the greatest benefit in eyes with high-risk characteristics (new vessels at the optic disc or vitreous hemorrhage with new vessels elsewhere, in which the risk of severe visual loss was reduced by 50%) (Group 1978).

#### **Surgical Vitrectomy for Vitreous Hemorrhage and Proliferative Diabetic Retinopathy**

Vitrectomy is used for treatment of eyes with advanced diabetic retinopathy, including proliferative diabetic retinopathy with nonclearing vitreous hemorrhage or fibrosis, areas of traction involving or threatening the macula, and, more recently, persistent diabetic macular edema with vitreous traction (Ho et al. 1992). The

Diabetic Retinopathy Vitrectomy Study (DRVS) randomized 616 eyes with recent vitreous hemorrhage and visual acuity of 5/200 or less for at least 1 month to undergo early vitrectomy within 6 months of observation (The Diabetic Retinopathy Vitrectomy Study Research Group 1985, 1988a, b, 1990). After 2 years of follow-up, 25% of the early vitrectomy group versus 15% of the observation group had 20/40 or greater vision, with the benefits maintained at 4 years and longer in individuals with type 1 diabetes.

### **Intravitreal Antiangiogenic Agents**

Currently, the small accepted treatment for PDR is panretinal photocoagulation (PRP) (Waisbourd et al. 2011). PRP is remarkably effective and has saved vision in many patients over the past several decades (The Diabetic Retinopathy Study Research Group 1981; Vander et al. 1991). Nevertheless, in up to 5% of the cases, neovessels continue to grow and vitrectomy is required, despite an appropriate initial treatment (Tremolada et al. 2012). In these cases, vitreous hemorrhage is common and frequently precludes laser completion (Fernando Arevalo 2013). Furthermore, PRP adverse effects are now widely recognized, such as worsening of DME and decline in peripheral and night vision function (Fong et al. 2007).

Considering the current evidence that VEGF takes part in the pathogenesis of PDR and the limitations of PRP, antiangiogenic agents have been recently admitted as new therapeutic options.

In a recent report, the DRCR.net showed evidence that antiangiogenic agents are effective in the management of proliferative diabetic retinopathy.

In conclusion, this exploratory randomized controlled trial suggests that intravitreal ranibizumab is safe and should be considered as a therapy for high-risk proliferative diabetic retinopathy eyes. The results obtained using IVR alone or in combined therapy are comparable or better than PRP alone. It remains to be demonstrated if this beneficial effect can be sustained for periods longer than 12 months.

## **Laser and Surgical Interventions for Diabetic Macular Edema**

### **Focal Laser Treatment**

Like panretinal laser photocoagulation, there is good evidence that focal laser treatment preserves vision in eyes with diabetic macular edema. The ETDRS randomized 1490 eyes with diabetic macular edema to receive focal laser treatment or observation. At 3 years, treatment significantly reduced moderate visual loss as compared with observation (Early Treatment Diabetic Retinopathy Study Research Group 1985) with the greatest benefits in eyes with clinically significant diabetic macular edema (Group 1987). Adverse effects include inadvertent foveal burn, central visual field defect, color vision abnormalities, retinal fibrosis, and spread of laser scars (Group 1995; Aiello 2003).

Focal laser applied directly to localized microvascular alterations such as microaneurysms and intraretinal vascular abnormalities has been shown to be effective,

particularly if there is a good correlation between the leaking vessels and the macular edema.

### **Sub-threshold Laser**

The ETDRS demonstrated that laser photocoagulation applied to patients with clinically significant macular edema reduced the incidence of visual loss by approximately 50% at 3 years of follow-up (Early Treatment Diabetic Retinopathy Study Research Group 1985). The conventional green laser treatment is applied in focal or grid pattern and produces visible burn in the retina. There have been reports demonstrating the enlargement of laser scars after treatment (Morgan and Schatz 1989).

Recently, sub-threshold micropulse diode laser was shown to be effective in the treatment of clinically significant macular edema and seems to have a theoretical advantage, since the laser burns will affect deeper layers with relative sparing of the inner neurosensory retina, reducing the scars and the complaints of paracentral scotoma posttreatment (Akduman and Olk 1999).

### **Surgical Vitrectomy for Diabetic Macular Edema**

Widespread or diffuse diabetic macular edema that is nonresponsive to focal laser treatment may benefit from vitrectomy (Yang 2000; La Heij et al. 2001; Dillinger and Mester 2004; Kralinger et al. 2006). However, the few randomized clinical trials to date have had small sample sizes and short follow-up, with inconsistent results. The presence of vitreous traction in macular edema, now readily documented with optical coherence tomography (OCT), in association with visual impairment, is currently a common indication for vitrectomy.

### **Intravitreal Corticosteroids**

Corticosteroids have potent anti-inflammatory and antiangiogenesis effects. Intravitreal triamcinolone, i.e., injection of triamcinolone acetonide into the vitreous cavity (Sobrin and D'Amico 2005), has been used for treatment of diabetic macular edema (Jonas and Söfker 2001; Martidis et al. 2002) with a number of small clinical trials demonstrating improvements in diabetic macular edema and visual acuity (Massin et al. 2004; Jonas et al. 2006a, b). In the largest randomized clinical trial having the longest follow-up yet reported, eyes with persistent diabetic macular edema were randomized to receive 4 mg of intravitreal triamcinolone or sham injection (saline injection into the subconjunctival space) (Gillies 2006). After 2 years, 19 of 34 intravitreal triamcinolone-treated eyes (56%) had a visual acuity improvement of 5 letters or more compared with 9 of 35 placebo-treated eyes (26%) ( $P = 0.007$ ). Overall, intravitreal triamcinolone-treated eyes had twice the chance of improved visual acuity and half the risk of further loss. However, many eyes required repeated injections (mean, 2.2), and there was significant intraocular pressure elevation (5 mm Hg in 68% of treated eyes vs. 10% of controls). Cataract surgery was required in 55% of intravitreal triamcinolone-treated eyes. Thus, while this study demonstrated significant efficacy of intravitreal triamcinolone in persistent diabetic macular edema, larger randomized clinical trials are needed to provide

further data on long-term benefits and safety. Additionally, the ideal dose of triamcinolone remains unclear (Spandau et al. 2005).

More recently, intravitreal or retinal implants have been developed, allowing extended drug delivery. An injectable, biodegradable intravitreal dexamethasone extended-release implant (Posurdex; Allergan, Irvine, California) was evaluated in a randomized clinical trial, with reported improvements in visual acuity and macular thickness (Kuppermann et al. 2003). A larger randomized clinical trial of Posurdex<sup>®</sup> for diabetic macular edema is currently under way.

The Iluvien<sup>®</sup> (fluocinolone acetonide implant, Alimera) is a small, nonbioerodable device that is injected in an office setting through a self-sealing wound with a 25-gauge inserter. The phase III FAME trial compared this device, formulated in two doses (0.2 µg/day and 0.5 µg/day), to standard of care, which could include laser or anti-VEGF injection, in 956 patients (Campochiaro 2011; Cunha-Vaz et al. 2014). Almost 30% of eyes receiving either the low-dose or high-dose formulation of the drug achieved three lines or more improvement of visual acuity, compared with 16% of controls, in the 3-year results of the study (Campochiaro 2011). Subgroup analysis showed that patients with diabetic macular edema duration of more than 3 years experienced better results than those with diabetic macular edema of less than 3-year duration (Antoszyk and Investigators 2011).

### **Intravitreal Antiangiogenic Agents**

Several randomized clinical trials are currently evaluating agents that suppress vascular endothelial growth factor (VEGF) for treatment of diabetic macular edema.

*Ranibizumab* (Lucentis, Genentech and Novartis) is an anti-VEGF agent used for treatment of neovascular age-related macular degeneration (Brown et al. 2006; Rosenfeld 2006) and may also be useful for diabetic retinopathy and diabetic macular edema (Chun et al. 2006). Randomized clinical trials (the RESOLVE and RESTORE studies) (Massin et al. 2010; Mitchell et al. 2011) have demonstrated beneficial effect of intravitreal administration of ranibizumab in diabetic macular edema. It is able in the short term to improve visual acuity when some degree of vision loss associated with clinically significant macular edema is present. The DRCR.net work confirmed and extended these findings. Intravitreal injection of ranibizumab is now approved for clinical use in diabetic macular edema (Elman et al. 2010).

*Bevacizumab* (Avastin, Genentech) is an anti-VEGF agent similar to ranibizumab that is approved for the treatment of disseminated colorectal cancer and not licensed for intraocular use. In a number of small studies and in noninferiority trials, bevacizumab appeared to show similar efficacy for treatment of neovascular age-related macular degeneration and may also be effective for diabetic macular edema (Avery 2006; Avery et al. 2006; Rosenfeld 2006; Spaide and Fisher 2006). Bevacizumab has attracted interest because of its low cost, but local and systemic safety is a concern (Gillies 2006; Carneiro et al. 2011).

*Aflibercept* (VEGF Trap-Eye, Bayer) is a recombinant fusion protein, consisting of portions of human VEGF receptor 1 and 2 extracellular domains fused to Fc

portion of IgG1 and formulated as an iso-osmotic solution for intravitreal administration (Ohr and Kaiser 2012).

The diabetic macular edema and VEGF Trap-Eye: Investigation of Clinical Impact (DA VINCI) study was a multicenter, randomized, double-masked phase II trial that compared various dosing regimens of aflibercept to macular grid photocoagulation. Compared to baseline, more patients treated with aflibercept than laser gained 0+, 10+, and 15+ letters of vision (93%, 64%, and 34% vs. 68%, 32%, and 21%). Reductions in central retinal thickness were greater in patients receiving aflibercept than laser ( $-127.3 \mu\text{m}$  to  $-194.5 \mu\text{m}$  vs.  $-67.9 \mu\text{m}$ ;  $p < 0.0066$  for each aflibercept group compared to laser) (Stewart 2012).

The relative efficacy and safety of intravitreal aflibercept, ranibizumab, and bevacizumab in the treatment of diabetic macular edema have been examined in a comparative clinical trial performed by the DRCR.net (Network 2015). At 89 clinical sites, 660 adults with diabetic macular edema were randomly assigned to aflibercept at a dose of 2.0 mg, ranibizumab at a dose of 0.3 mg, and bevacizumab at a dose of 1.25 mg. The study drugs were administered as often as every 4 weeks. The primary outcome was the mean change in visual acuity at 1 year.

Although the improvement was greater with aflibercept than with the other two drugs ( $P < 0.001$  for aflibercept vs. bevacizumab and  $P = 0.03$  for aflibercept vs. ranibizumab), it was not clinically meaningful, because the difference was driven by the eyes with worse visual acuity at baseline ( $P < 0.001$  for interaction).

When the initial visual acuity letter score was 78 to 69 (equivalent to approximately 20/32 to 20/40) (51% of participants), the mean improvement was 8.0 with aflibercept, 7.5 with bevacizumab, and 8.3 with ranibizumab ( $P > 0.50$  for each pairwise comparison). When the initial letter score was less than 69 (approximately 20/50 or worse), the mean improvement was 18.9 with aflibercept, 11.8 with bevacizumab, and 14.2 with ranibizumab ( $P < 0.001$  for aflibercept vs. bevacizumab,  $P = 0.003$  for aflibercept vs. ranibizumab, and  $P = 0.21$  for ranibizumab vs. bevacizumab). There were no significant differences among the study groups in the rates of serious adverse events ( $P = 0.40$ ).

Intravitreal aflibercept, bevacizumab, or ranibizumab improved vision in eyes with center-involved diabetic macular edema, but the relative effect depended on baseline visual acuity. When the initial visual acuity loss was mild, there were no apparent differences, on average, among study groups. At worse levels of initial visual acuity, aflibercept was more effective at improving vision.

## Review of Approaches for the Treatment of Diabetic Macular Edema

### Recommendations for the Treatment of Diabetic Macular Edema

The goal of treatment with laser photocoagulation was mostly visual acuity stabilization. With the approval of antiangiogenic drugs for the treatment of visual impairment due to diabetic macular edema, the goal of therapy is now primarily improvement or restoration of visual acuity, with stabilization of vision and prevention of further vision loss as a key secondary goal.

**Fig. 11** Treatment algorithm for diabetic macular edema

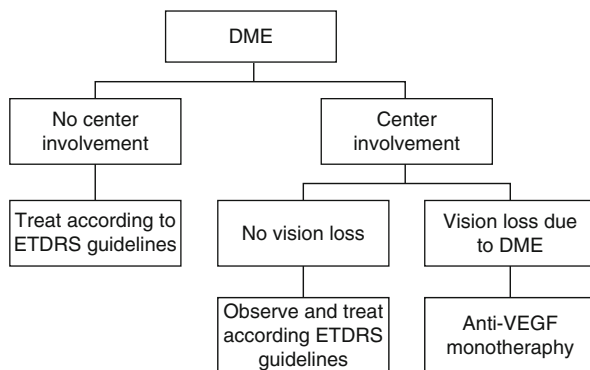

Treatment recommendations for diabetic macular edema are based on involvement of the center of the macula (Fig. 11). No new recommendations for the treatment of diabetic macular edema without center involvement, or for diabetic macular edema with center involvement but without vision loss, are required as current ETDRS guidelines remain appropriate (Group 1987); antiangiogenic drug monotherapy is now recommended for the treatment of diabetic macular edema with central involvement, with vision loss considered due to diabetic macular edema. In that respect, it is important to exclude other potential causes of vision loss such as epiretinal membrane, vitreomacular traction, or macular ischemia and other conditions such as cataract or glaucoma.

Systemic factors are key to the management of diabetes, and patients should attempt to achieve optimal control of hemoglobin A1c, lipid levels, and especially blood pressure (Cheung et al. 2010). Intensive control of blood glucose and hypertension reduces development of clinically significant macular edema (UK Prospective Diabetes Study (UKPDS) Group 1998a, b). Achieving control of systemic factors reduces retinal thickness and improves visual acuity to some extent in patients with very mild diabetic macular edema in the absence of other interventions (Singh et al. 2006).

Surgery should be considered in patients with diabetic macular edema due to a significant epiretinal membrane or demonstrated vitreomacular traction.

### Characterization of Responders to Treatment

The major pathways of progression in diabetic retinopathy are leakage (alterations of the blood-retinal barrier), microaneurysms, inflammation, and ischemia. The therapies that we employ for treatment of diabetic macular edema must act on one or more of these pathways. The rationale for use of vascular endothelial growth factor (VEGF) inhibitors in diabetic macular edema is the association of VEGF with vascular leakage; VEGF increases leakage, and anti-VEGF action controls leakage. Anti-VEGF therapy may also have an effect on ischemia, depending on the level of ischemia. Steroids act on both leakage and, especially, inflammation. Although we do not fully understand the mechanism of action of laser, we observe that it stabilizes disease activity in diabetic macular edema.

Response to anti-VEGF treatment in diabetic macular edema is generally better than response to any other means of treatment. A randomized controlled trial by the Diabetic Retinopathy Clinical Research Network showed that intravitreal ranibizumab (Lucentis, Genentech) plus prompt or deferred laser resulted in greater visual acuity gain than treatment with either intravitreal triamcinolone acetate plus laser or laser alone (Elman et al. 2010). However, in clinical trials we are always looking at the mean results of a number of patients. In any trial of a proposed diabetic macular edema therapy, there will be good responders who achieve decreased thickness and increased visual acuity in a relatively short period after the initial injections, but there will also be poor responders and nonresponders. It would be helpful to know more about the nonresponders in order to choose alternative treatments to which they might respond better.

## **Role of Early Screening for Diabetic Retinopathy in Patients with Diabetes Mellitus**

### **Screening for High-Risk Diabetic Retinopathy**

The major risk factors for developing diabetic retinopathy are duration of diabetes (Elshafei et al. 2010; Leske et al. 2010) and severity of hyperglycemia ((DCCT) 1995; Elshafei et al. 2010).

Timely intervention by laser photocoagulation can reduce severe visual loss by 90% according to ETDRS (Group 1991) and Diabetic Retinopathy Study (DRS) (The Diabetic Retinopathy Study Research Group 1981). Intravitreal anti-VEGF injections are offering new treatment alternatives and offer for the first time vision recovery. In any case, early detection of diabetic retinopathy vision-threatening complications and timely treatment of these patients remain a major challenge for healthcare providers.

Screening is a process by which unrecognized diseases or defects are identified by means of rapidly applied tests in apparently healthy individuals.

The four cardinal principles for screening recommended by the WHO (World Health Organization 2001) are as follows:

1. The condition should be an important health problem with a recognizable pre-symptomatic state.
2. An appropriate screening procedure which is acceptable both to the public and healthcare professionals should be available.
3. Treatment for patients with recognizable disease should be safe, effective, and universally agreeable.
4. The economic cost of early diagnosis and treatment should be considered in relation to total expenditure on healthcare, including the consequences for leaving the disease untreated.

Diabetic retinopathy conforms well to these principles. In diabetic retinopathy, early detection and treatment is of vital importance as it may prevent vision loss and blindness.



Diabetic retinopathy is a chronic disease with a long latent phase. Among the diabetics, 10–15% constitutes type 1 diabetics and the remainders are type 2 diabetics. In about 10 years, diabetic retinopathy develops in 71–90% of patients with type 1 diabetes, and this incidence rises to 95% in 20–30 years. Out of these, 30–50% of patients have proliferative diabetic retinopathy (Klein et al. 1984a). In type 2 diabetes, 67% of patients develop diabetic retinopathy after 10 years (Klein et al. 1992), with 10% of patients showing features of proliferative diabetic retinopathy. Up to a fifth of newly diagnosed diabetics have some form of retinopathy. Therefore, screening will prove to be beneficial at any stage of this long latent phase of the disease and will also be helpful in avoiding blindness among 90% of patients (Ferris 1994).

Screening for diabetic retinopathy is cost-effective when compared with disability loss for people going blind in the absence of a screening program. The compliance for the screening program should be more than 80% for more gains (Dasbach et al. 1991). The funds invested to increase compliance are small but a vital component of the costs of a screening program.

The efficacy of screening for high-risk DR has been demonstrated in places such as Iceland or Sweden, where it has led to reduction of diabetes-related blindness (Stefánsson et al. 2000). A countrywide screening program has been established in the UK (Scanlon 2008), and the full impact of this intervention will become available in the coming years.

It is suggested that patients with type 1 diabetes should be screened annually for retinopathy, 5 years after the onset of diabetes. Patients with type 2 diabetes should have an initial examination for retinopathy shortly after the diagnosis, and the examination should be repeated every other year. Pregnant women with diabetes should have a comprehensive eye examination in first trimester and close follow-up throughout pregnancy.

### **Criteria for Review and Referral**

1. Biannual review without referral:
  - (a) Normal fundus
2. Annual (or more frequent) review without referral:
  - (a) Background diabetic retinopathy with small hemorrhages and/or small hard exudates more than one disc diameter distant from the fovea
3. Early referral to ophthalmologist for treatment:
  - (a) Background diabetic retinopathy with small hemorrhages and/or small hard exudates less than one disc diameter distant from the fovea
  - (b) Maculopathy
4. Urgent referral to ophthalmologist for treatment:
  - (a) Proliferative diabetic retinopathy
  - (b) Vitreous hemorrhage
  - (c) Retinal detachment

### **Screening Tests for Diabetic Retinopathy**

Many different modalities of screening are in use depending on the availability of local facilities. These include number of available ophthalmologists, other trained

healthcare professionals, and equipment and resources available for screening. However, whichever method is used, it should have sufficient sensitivity (>90%) and specificity (>90%) for a single-modality screening process. The minimum sensitivity for any method to be effective if it is repeated at the recommended interval is 60%. This level of sensitivity can be achieved with ophthalmoscopy through dilated pupils (sensitivity = 65.7% and specificity = 93.8%) (Owens et al. 1998) by suitably trained observers (principally ophthalmologists, optometrists, general practitioners, or physicians) or with non-mydriatic photography (sensitivity = 87.3% and specificity = 84.8%) (Moss et al. 1985; Owens et al. 1998; Benbassat and Polak 2009). The sensitivity of detecting diabetic retinopathy by retinal photography has been reported to be higher than that of direct ophthalmoscopy (64% vs. 41%; 95% confidence interval of difference, 1.2–44.3%) (Siu et al. 1998). Specificities of retinal photography and direct ophthalmoscopy have been reported to be 90% (95% confidence interval, 84–96%) and 93% (95% confidence interval, 88–97%), respectively (Siu et al. 1998). Single-field fundus photography with interpretation by trained readers could serve as a screening tool to identify patients of diabetic retinopathy. Combining two modalities of screening (e.g., direct ophthalmoscopy in conjunction with retinal photography) provides excellent sensitivity (87.3%) (Benbassat and Polak 2009) but increases the cost per case screened and is often only possible in a hospital-based setting. Screening involves measurement of visual acuity for both distance and near vision using ETDRS chart.

Tele-medical screening may be undertaken to screen patients with diabetic retinopathy. A major advantage of digital technologies is the ability to transmit images to a centralized reading center for grading. This involves a remote imaging system, a centralized grading center, and a data storage system. A significant increase in rate of diabetic retinopathy surveillance and in the rate of laser treatment for diabetic retinopathy may be achieved by implementing retinal image technology in the primary care setting.

The use of the non-mydriatic camera (sensitivity = 97.7% and specificity = 84.0%) (Boucher et al. 2003) empowers an additional cadre of health professionals who can participate in screening programs. Screening of diabetics by ophthalmic technicians increases the outreach to the periphery with sufficient sensitivity and specificity and is cost-effective (Wilson et al. 2010).

### **Automated Computer-Aided Analysis of Fundus Digital Photographs in Diabetic Retinopathy Screening**

The development of systematic programs of screening for retinopathy has been identified as an urgent healthcare need. Indeed, studies have indicated that the severity of vision loss due to diabetes is caused largely by lack of screening (Oliveira et al. 2011).

We have developed and evaluated a novel two-step approach that automatically screens color fundus photographs in patients with the use of sequential examinations from the same patient to analyze the evolution of the disease in that patient. The automated grading system consists of software earmarking microaneurysms and “red-dot-like” vascular lesions. It includes a co-registration algorithm that allows

comparison within the same retinal location between different visits for the same eye. The system generates in a first-step single analysis one of two possible outputs, “disease” or “no disease.” “Disease” category comprehends thus those images where vascular lesions are found in the central macula corresponding to level 20 and above of the ETDRS scale, therefore including mild retinopathy, maculopathy, advanced nonproliferative retinopathy, and proliferative retinopathy. In the one-step analysis, the algorithm detects the presence of red-dot-like lesions in fields 1 and 2 (field 1 is centered on the optic disc, and field 2 is centered on the fovea). We combine this initial analysis (first step) with a second analysis that compares two different and consecutive examinations from the same patient from two successive screenings with approximately 1-year interval. The images from the field centered on the macula are co-registered to complete a difference analysis which will indicate disease activity in the central 3000  $\mu\text{m}$  circle of the macula. The results show a clear improvement over available fully automated screening algorithms with a sensitivity of 95.8% and a specificity of 63.2%. The system has shown that it can perform a useful role by eliminating 50% or more of the screening population who have no retinopathy. Furthermore, it did not miss urgent cases for referral, allowing, therefore, an important reduction in the burden of manual grading with less cost. This two-step analysis shows a clear improvement in specificity over other available automated systems, and its integration in a yearly screening program now in progress is expected to bring progressive decrease in the burden of human grading by safely decreasing the number of false-positive results to be submitted to human grading, with economic advantage making diabetic retinopathy screening more feasible (Ribeiro et al. 2014).

### **Role of Telemedicine in Eye Care in Diabetes**

The standard of care for diabetic patients is at least biannual fundus examination by a qualified eye care provider (Williams et al. 2004; American Academy of Ophthalmology Retina Panel 2010). With early detection and treatment of diabetic eye disease, vision loss can be mitigated (The National Eye Institute 1993). Unfortunately, only 30–60% of individuals with eye disease receive a yearly eye exam (Lee et al. 2003; Varma et al. 2008). Telemedicine has the potential to increase the number of patients being screened for eye disease; it has been shown to provide cost-effectiveness and total savings in terms of public health spending (Javitt and Aiello 1996).

Telemedicine provides a reliable, cost-effective means of screening diabetic patients for retinopathy. Since the number of diabetics is growing fast, but the supply of eye care practitioners is not, healthcare resources are strained and becoming more so.

---

### **Conclusions**

Overall, the results of the trials reported above suggest that interventions targeted at potential pathogenic mechanisms may be effective in early mild, rather than moderate or more advanced, stages of retinopathy in which damage to the capillary wall and the

neuroretina may already be too advanced. Here the question arises of whether a “point of no return” exists in the natural history of DR. Antiplatelet agents appeared to slow down retinopathy at a very early stage characterized by the presence of microaneurysms alone (Plu et al. 1990), but not later when capillary occlusion becomes the prevailing feature (TIMAD Study Group 1990). Similarly, in DIRECT-Protect 2 (Sjølief et al. 2008), administration of candesartan was associated with regression of minimal to mild retinopathy (occasional microaneurysms, microhemorrhages, hard exudates, and/or cotton wool spots), whereas nonproliferative stages, though classified as moderate, proved nonresponsive, suggesting that also blockade of the RAS could be effective earlier than originally envisaged, again when damage of the capillary wall is minimal. This suggests that overactivation of the intraocular RAS may exert its pathogenic effects through mechanisms different from VEGF activation or that VEGF might have pathogenic effects independent of its ability to increase vessel wall permeability and angiogenesis, possibly involving its neuroprotective characteristics. However, data from FIELD (Hermans 2011) and ACCORD (Wright and Dodson 2011) appear to show that progression of retinopathy can be stopped by fenofibrate at more advanced stages, moderate and severe nonproliferative, suggesting that different pathogenic mechanisms, responsive to different pharmacological agents, may intervene in various stages of this complication.

Progress in medical treatment of DR remains incomplete, just like our understanding of the mechanisms underlying this complication. More is achieved in the advanced stages, using VEGF inhibitors, than early in the evolution of DR, but we are still far from the day when retinopathy will be treated aiming directly at a cause (as we do, e.g., with iron for iron-deficient anemia) or a mechanism (as with proton pump inhibitors for peptic ulcers). Causes for failure so far to identify a *primum movens* for retinopathy and, more generally, diabetic microangiopathy involve a series of good reasons: lack of funding and researchers dedicated to the specific problem, a presumably multifactorial pathogenesis, and the undoubted complexity of the phenomena involved. It is hoped that, as diabetes and its complications rise worldwide, the mere health and economic size of its consequences will stimulate further research into this field of human disease.

---

## References

- Agemy SA, Sripsema NK, Shah CM, Chui T, Garcia PM, Lee JG, et al. Retinal vascular perfusion density mapping using optical coherence tomography angiography in normals and diabetic retinopathy patients. *Retina*. 2015;35(11):2353–63.
- Aiello LM. Perspectives on diabetic retinopathy. *Am J Ophthalmol*. 2003;136(1):122–35.
- Akduman L, Olk RJ. Subthreshold (invisible) modified grid diode laser photocoagulation in diffuse diabetic macular edema (DDME). *Ophthalmic Surg Lasers*. 1999;30(9):706–14.
- Alkuraya H, Kangave D, Abu El-Asrar AM. The correlation between optical coherence tomographic features and severity of retinopathy, macular thickness and visual acuity in diabetic macular edema. *Int Ophthalmol*. 2005;26(3):93–9.
- American Academy of Ophthalmology Retina Panel. Preferred practice pattern guidelines: diabetic retinopathy. San Francisco: American Academy of Ophthalmology; 2010.

- Antonetti DA, Barber AJ, Bronson SK, Freeman WM, Gardner TW, Jefferson LS, et al. Diabetic retinopathy: seeing beyond glucose-induced microvascular disease. *Diabetes*. 2006;55(9):2401–11.
- Antoszyk AN, Investigators F. Efficacy and safety of ILUVIEN® (Fluocinolone acetonide [FAc] intravitreal insert) for the treatment of diabetic macular edema. *Invest Ophthalmol Vis Sci*. 2011;52(14):6645.
- Appen RE, Chandra SR, Klein R, Myers FL. Diabetic papillopathy. *Am J Ophthalmol*. 1980;90(2):203–9.
- Arend O, Wolf S, Harris A, Reim M. The relationship of macular microcirculation to visual acuity in diabetic patients. *Arch Ophthalmol (Chicago, 1960)* [Internet]. 1995 [cited 2016 May 24];113(5):610–4. <http://www.ncbi.nlm.nih.gov/pubmed/7748131>
- Armary MF, Baloglou PJ. Diabetes mellitus and the eye. 1. Changes in the anterior segment. *Arch Ophthalmol (Chicago, 1960)*. 1967;77(4):485–92.
- Asnaghi V, Gerhardinger C, Hoehn T, Adeboje A, Lorenzi M. A role for the polyol pathway in the early neuroretinal apoptosis and glial changes induced by diabetes in the rat. *Diabetes*. 2003;52(2):506–11.
- Avery RL. Regression of retinal and iris neovascularization after intravitreal bevacizumab (Avastin) treatment. *Retina*. 2006;26(3):352–4.
- Avery RL, Pearlman J, Pieramici DJ, Rabena MD, Castellarin AA, Nasir MA, et al. Intravitreal bevacizumab (Avastin) in the treatment of proliferative diabetic retinopathy. *Ophthalmology*. 2006;113(10):1695.e1–15.
- Bandello F, Tejerina AN, Vujosevic S, Varano M, Egan C, Sivaprasad S, et al. Retinal layer location of increased retinal thickness in eyes with subclinical and clinical macular edema in diabetes type 2. *Ophthalmic Res*. 2015;54(3):112–7.
- Bearse MA, Han Y, Schneck ME, Adams AJ. Retinal function in normal and diabetic eyes mapped with the slow flash multifocal electroretinogram. *Invest Ophthalmol Vis Sci*. 2004;45(1):296–304.
- Becker B. Diabetes mellitus and primary open-angle glaucoma. The XXVII Edward Jackson Memorial Lecture. *Am J Ophthalmol*. 1971;71(1 Pt 1):1–16.
- Beltramo E, Berrone E, Tarallo S, Porta M. Effects of thiamine and benfotiamine on intracellular glucose metabolism and relevance in the prevention of diabetic complications. *Acta Diabetol*. 2008;45(3):131–41.
- Benbassat J, Polak BCP. Reliability of screening methods for diabetic retinopathy. *Diabet Med*. 2009;26(8):783–90.
- Beulens JWJ, Patel A, Vingerling JR, Cruickshank JK, Hughes AD, Stanton A, et al. Effects of blood pressure lowering and intensive glucose control on the incidence and progression of retinopathy in patients with type 2 diabetes mellitus: a randomised controlled trial. *Diabetologia*. 2009;52(10):2027–36.
- Boucher MC, Gresset JA, Angioi K, Olivier S. Effectiveness and safety of screening for diabetic retinopathy with two nonmydriatic digital images compared with the seven standard stereoscopic photographic fields. *Can J Ophthalmol*. 2003;38(7):557–68.
- Bourne RRA, Jonas JB, Flaxman SR, Keeffe J, Leasher J, Naidoo K, et al. Prevalence and causes of vision loss in high-income countries and in Eastern and Central Europe: 1990–2010. *Br J Ophthalmol*. 2014;98(5):629–38.
- Bower JK, Brancati FL, Selvin E. No ethnic differences in the association of glycosylated hemoglobin with retinopathy: the national health and nutrition examination survey 2005–2008. *Diabetes Care*. 2013;36(3):569–73.
- Bresnick GH, Palta M. Predicting progression to severe proliferative diabetic retinopathy. *Arch Ophthalmol (Chicago, 1960)*. 1987;105(6):810–4.
- Bresnick GH, Korth K, Groo A, Palta M. Electroretinographic oscillatory potentials predict progression of diabetic retinopathy. Preliminary report. *Arch Ophthalmol (Chicago, 1960)*. 1984;102(9):1307–11.
- Bresnick GH, Condit RS, Palta M, Korth K, Groo A, Syrjala S. Association of hue discrimination loss and diabetic retinopathy. *Arch Ophthalmol (Chicago, 1960)*. 1985;103(9):1317–24.

- Brown DM, Kaiser PK, Michels M, Soubrane G, Heier JS, Kim RY, et al. Ranibizumab versus verteporfin for neovascular age-related macular degeneration. *N Engl J Med.* 2006;355(14):1432–44.
- Brownlee M. Biochemistry and molecular cell biology of diabetic complications. *Nature.* 2001;414(6865):813–20.
- Caird FI, Hutchinson M, Pirie A. Cataract and diabetes. *Br Med J.* 1964;2(5410):665–8.
- Camposchiaro P. Sustained release corticosteroid for DME. In: Paper presented at: Angiogenesis, Exudation and Degeneration – Feb 12, 2011. Miami; 2011.
- Carneiro AM, Barthelmes D, Falcão MS, Mendonça LS, Fonseca SL, Gonçalves RM, et al. Arterial thromboembolic events in patients with exudative age-related macular degeneration treated with intravitreal bevacizumab or ranibizumab. *Int J Ophthalmol.* 2011;225(4):211–21.
- Charonis AS, Reger LA, Dege JE, Kouzi-Koliakos K, Furcht LT, Wohlhueter RM, et al. Laminin alterations after in vitro nonenzymatic glycosylation. *Diabetes.* 1990;39(7):807–14.
- Chaturvedi N, Sjolie AK, Stephenson JM, Abrahamian H, Keipes M, Castellarin A, et al. Effect of lisinopril on progression of retinopathy in normotensive people with type 1 diabetes. The EUCLID Study Group. EURODIAB Controlled Trial of Lisinopril in Insulin-Dependent Diabetes Mellitus. *Lancet.* 1998;351(9095):28–31.
- Chaturvedi N, Porta M, Klein R, Orchard T, Fuller J, Parving HH, et al. Effect of candesartan on prevention (DIRECT-Prevent 1) and progression (DIRECT-Protect 1) of retinopathy in type 1 diabetes: randomised, placebo-controlled trials. *Lancet.* 2008;372(9647):1394–402.
- Cheung N, Mitchell P, Wong TY. Diabetic retinopathy. *Lancet.* 2010;376(9735):124–36.
- Chew EY, Ambrosius WT, Davis MD, Danis RP, Gangaputra S, Greven CM, et al. Effects of medical therapies on retinopathy progression in type 2 diabetes. *N Engl J Med.* 2010;363(3):233–44.
- Chun DW, Heier JS, Topping TM, Duker JS, Bankert JM. A pilot study of multiple intravitreal injections of ranibizumab in patients with center-involving clinically significant diabetic macular edema. *Ophthalmology.* 2006;113(10):1706–12.
- Corrall RJ. Coincidental changes in conscious level and lens translucency during treatment of diabetic ketoacidosis. *Br J Ophthalmol.* 1975;59(4):233–5.
- Coscas G, Soubrane G. Optical coherence tomography in age-related macular degeneration: OCT in AMD. Heidelberg: Springer; 2009.
- Csaky KG, Richman EA, Ferris FL. Report from the NEI/FDA ophthalmic clinical trial design and endpoints symposium. *Invest Ophthalmol Vis Sci.* 2008;49(2):479–89.
- Cunha-Vaz J. Diabetic retinopathy. New perspectives for personalized management. *Prémio BIAL de Medicina Clínica 2012, Fundação BIAL.* 2014. ISBN 978-989-8483-15-7.
- Cunha-Vaz J, Coscas G. Diagnosis of macular edema. *Int J Ophthalmol.* 2010;224(Suppl 1):2–7.
- Cunha-Vaz J, Faria de Abreu JR, Campos AJ. Early breakdown of the blood-retinal barrier in diabetes. *Br J Ophthalmol.* 1975;59(11):649–56.
- Cunha-Vaz J, Ashton P, Iezzi R, Camposchiaro P, Dugel PU, Holz FG, et al. Sustained delivery fluocinolone acetonide vitreous implants: long-term benefit in patients with chronic diabetic macular edema. *Ophthalmology.* 2014;121(10):1892–903.
- Dasbach EJ, Fryback DG, Newcomb PA, Klein R, Klein BE. Cost-effectiveness of strategies for detecting diabetic retinopathy. *Med Care.* 1991;29(1):20–39.
- Daubs JG. Diabetes screening with corneal aesthesiometer. *Am J Optom Physiol Optic.* 1975;52(1):31–5.
- (DCCT) DC and CTRG. The relationship of glycemic exposure (HbA1c) to the risk of development and progression of retinopathy in the diabetes control and complications trial. *Diabetes.* 1995;44(8):968–83.
- Diabetic Retinopathy Vitrectomy Study Group. Early vitrectomy for severe vitreous hemorrhage in diabetic retinopathy. Four-year results of a randomized trial: Diabetic Retinopathy Vitrectomy Study Report 5. *Arch Ophthalmol (Chicago, 1960).* 1990;108(7):958–64.

- Diabetic Retinopathy Vitrectomy Study Research Group. Early vitrectomy for severe proliferative diabetic retinopathy in eyes with useful vision. Clinical application of results of a randomized trial – Diabetic Retinopathy Vitrectomy Study Report 4. The Diabetic Retinopathy Vitrectomy Study Research Group. *Ophthalmology*. 1988a;95(10):1321–34.
- Diabetic Retinopathy Vitrectomy Study Research Group. Early vitrectomy for severe proliferative diabetic retinopathy in eyes with useful vision. Results of a randomized trial – Diabetic Retinopathy Vitrectomy Study Report 3. The Diabetic Retinopathy Vitrectomy Study Research Group. *Ophthalmology*. 1988b;95(10):1307–20.
- Dillingner P, Mester U. Vitrectomy with removal of the internal limiting membrane in chronic diabetic macular oedema. *Graefes Arch Clin Exp Ophthalmol*. 2004;242(8):630–7.
- Ditzel J, White P. Central retinal vein occlusion in juvenile diabetes; case report with consideration of the pathogenic relationship between diabetic retinopathy and retinal vein occlusion. *J Chronic Dis*. 1956;3(3):253–62.
- Ditzel J, Sargeant L, Hadley WB. The relationship of abnormal vascular responses to retinopathy and nephropathy in diabetics. *AMA Arch Intern Med*. 1958;101(5):912–20.
- Drexler WD. Cellular and functional optical coherence tomography of the human retina: the Cogan lecture. *Invest Ophthalmol Vis Sci*. 2007;48(12):5339–51. <https://doi.org/10.1167/iov.07-0895>.
- Du XL, Edelstein D, Rossetti L, Fantus IG, Goldberg H, Ziyadeh F, et al. Hyperglycemia-induced mitochondrial superoxide overproduction activates the hexosamine pathway and induces plasminogen activator inhibitor-1 expression by increasing Sp1 glycosylation. *Proc Natl Acad Sci U S A*. 2000;97(22):12222–6.
- Early Treatment Diabetic Retinopathy Study Research Group. Photocoagulation for diabetic macular edema. Early Treatment Diabetic Retinopathy Study report number 1. Early Treatment Diabetic Retinopathy Study research group. *Arch Ophthalmol (Chicago, 1960)*. 1985;103(12):1796–806.
- Early Treatment Diabetic Retinopathy Study Research Group. Early Treatment Diabetic Retinopathy Study design and baseline patient characteristics. ETDRS report number 7. *Ophthalmology*. 1991a;98(5 Suppl):741–56.
- Early Treatment Diabetic Retinopathy Study Research Group. Effects of aspirin treatment on diabetic retinopathy. ETDRS report number 8. Early Treatment Diabetic Retinopathy Study Research Group. *Ophthalmology*. 1991b;98(5 Suppl):757–65.
- Elman MJ, Aiello LP, Beck RW, Bressler NM, Bressler SB, Edwards AR, et al. Randomized trial evaluating ranibizumab plus prompt or deferred laser or triamcinolone plus prompt laser for diabetic macular edema. *Ophthalmology*. 2010;117(6):1064–1077.e35.
- Elshafei M, Gamra H, Khandekar R, Al Hashimi M, Pai A, Ahmed MF. Prevalence and determinants of diabetic retinopathy among persons  $\geq 40$  years of age with diabetes in Qatar: a community-based survey. *Eur J Ophthalmol*. 2010;21(1):39–47.
- Epstein DL. Reversible unilateral lens opacities in a diabetic patient. *Arch Ophthalmol (Chicago, 1960)*. 1976;94(3):461–3.
- Fernando AJ. Intravitreal bevacizumab as anti-vascular endothelial growth factor in the management of complications of proliferative diabetic retinopathy. *Med Hypothesis, Discov Innov Ophthalmol*. 2013;2(1):20–4.
- Ferris FL. Results of 20 years of research on the treatment of diabetic retinopathy. *Prev Med (Baltim)*. 1994;23(5):740–2.
- Fletcher EL, Phipps JA, Ward MM, Puthussery T, Wilkinson-Berka JL. Neuronal and glial cell abnormality as predictors of progression of diabetic retinopathy. *Curr Pharm Des*. 2007;13(26):2699–712.
- Fong DS, Girach A, Boney A. Visual side effects of successful scatter laser photocoagulation surgery for proliferative diabetic retinopathy: a literature review. *Retina*. 2007;27(7):816–24.
- Ford ES, Li C, Little RR, Mokdad AH. Trends in A1C concentrations among U.S. adults with diagnosed diabetes from 1999 to 2004. *Diabetes Care*. 2008;31(1):102–4.
- Fortune B, Schneck ME, Adams AJ. Multifocal electroretinogram delays reveal local retinal dysfunction in early diabetic retinopathy. *Invest Ophthalmol Vis Sci*. 1999;40(11):2638–51.

- Frisén L, Frisén M. A simple relationship between the probability distribution of visual acuity and the density of retinal output channels. *Acta Ophthalmol.* 1976;54(4):437–44.
- García-Ramírez M, Hernández C, Villarroel M, Canals F, Alonso MA, Fortuny R, et al. Interphotoreceptor retinoid-binding protein (IRBP) is downregulated at early stages of diabetic retinopathy. *Diabetologia.* 2009;52(12):2633–41.
- Gass JD. Ocular manifestations of acute mucormycosis. *Arch Ophthalmol (Chicago, 1960).* 1961;65:226–37.
- Gasset AR, Braverman LE, Fleming MC, Arky RA, Alter BR. Tear glucose detection of hyperglycemia. *Am J Ophthalmol.* 1968;65(3):414–20.
- Gaucher D, Tadayoni R, Erginay A, Haouchine B, Gaudric A, Massin P. Optical coherence tomography assessment of the vitreoretinal relationship in diabetic macular edema. *Am J Ophthalmol.* 2005;139(5):807–13.
- Giardino I, Edelstein D, Brownlee M. Nonenzymatic glycosylation in vitro and in bovine endothelial cells alters basic fibroblast growth factor activity. A model for intracellular glycosylation in diabetes. *J Clin Invest.* 1994;94(1):110–7.
- Gill GV, Woodward A, Pradhan S, Wallymahmed M, Groves T, English P, et al. Intensified treatment of type 2 diabetes – positive effects on blood pressure, but not glycaemic control. *QJM.* 2003;96(11):833–6.
- Gillies MC. What we don't know about avastin might hurt us. *Arch Ophthalmol (Chicago, 1960).* 2006;124(10):1478–9.
- Goldstein JE, Cogan DG. Diabetic ophthalmoplegia with special reference to the pupil. *Arch Ophthalmol (Chicago, 1960).* 1960;64:592–600.
- Green FD, Ghafour IM, Allan D, Barrie T, McClure E, Foulds WS. Colour vision of diabetics. *Br J Ophthalmol.* 1985;69(7):533–6.
- Group ETDRSR. Treatment techniques and clinical guidelines for photocoagulation of diabetic macular edema. Early Treatment Diabetic Retinopathy Study report number 2. Early Treatment Diabetic Retinopathy Study Research Group. *Ophthalmology.* 1987;94(7):761–74.
- Group ETDRSR. Early photocoagulation for diabetic retinopathy. *Ophthalmology.* 1991;98(5):766–85.
- Group ETDRSR. Focal photocoagulation treatment of diabetic macular edema. Relationship of treatment effect to fluorescein angiographic and other retinal characteristics at baseline: ETDRS report no. 19. Early Treatment Diabetic Retinopathy Study Research Group. *Arch Ophthalmol (Chicago, 1960).* 1995;113(9):1144–55.
- Group TDRSR. Photocoagulation treatment of proliferative diabetic retinopathy: the second report of diabetic retinopathy study findings. *Ophthalmology.* 1978;85(1):82–106.
- Gundersen HJG. An abnormality of the central autonomic nervous system in long-term diabetes: absence of hippus. *Diabetologia.* 1974;10:366.
- Gupta A, Jain IS, Gangwar DN, Malik AK. The syndrome of juvenile diabetes mellitus, diabetes insipidus, deafness, optic atrophy and hypothalamic dysfunction (a case report). *Indian J Ophthalmol.* 1979;26(4):38–40.
- Hammes H-P, Welp R, Kempe H-P, Wagner C, Siegel E, Holl RW. Risk factors for retinopathy and DME in type 2 diabetes-results from the German/Austrian DPV database. *PLoS One.* 2015;10(7):e0132492.
- Han Y, Barse MA, Schneck ME, Barez S, Jacobsen CH, Adams AJ. Multifocal electroretinogram delays predict sites of subsequent diabetic retinopathy. *Invest Ophthalmol Vis Sci.* 2004;45(3):948–54.
- Hatfield RE, Gastineau CF, Rucker CW. Asteroid bodies in the vitreous: relationship to diabetes and hypercholesterolemia. *Proc Staff Meet Mayo Clin.* 1962;37:513–4.
- Hee MR, Puliafito CA, Wong C, Duker JS, Reichel E, Rutledge B, et al. Quantitative assessment of macular edema with optical coherence tomography. *Arch Ophthalmol (Chicago, 1960).* 1995;113(8):1019–29.
- Henkind P, Wise GN. Descemet's wrinkles in diabetes. *Am J Ophthalmol.* 1961;52:371–4.



- Hermans MP. Non-invited review: prevention of microvascular diabetic complications by fenofibrate: lessons from FIELD and ACCORD. *Diab Vasc Dis Res.* 2011;8(3):180–9.
- Ho T, Smiddy WE, Flynn HW. Vitrectomy in the management of diabetic eye disease. *Surv Ophthalmol.* 1992;37(3):190–202.
- Holman RR, Paul SK, Bethel MA, Matthews DR, Neil HAW. 10-year follow-up of intensive glucose control in type 2 diabetes. *N Engl J Med.* 2008;359(15):1577–89.
- Holopigian K, Seiple W, Lorenzo M, Carr R. A comparison of photopic and scotopic electroretinographic changes in early diabetic retinopathy. *Invest Ophthalmol Vis Sci.* 1992;33(10):2773–80.
- Hovind P, Tarnow L, Rossing K, Rossing P, Eising S, Larsen N, et al. Decreasing incidence of severe diabetic microangiopathy in type 1 diabetes. *Diabetes Care.* 2003;26(4):1258–64.
- Hreidarsson AB. Pupil motility in long-term diabetes. *Diabetologia.* 1979;17(3):145–50.
- Jansson RW, Raeder MB, Krohn J. Photopic full-field electroretinography and optical coherence tomography in type 1 diabetic retinopathy. *Graefes Arch Clin Exp Ophthalmol.* 2015;253(7):989–97.
- Javitt JC, Aiello LP. Cost-effectiveness of detecting and treating diabetic retinopathy. *Ann Intern Med.* 1996;124(1 Pt 2):164–9.
- Jenkins TC, Cartwright JP. The electroretinogram in minimal diabetic retinopathy. *Br J Ophthalmol.* 1990;74(11):681–4.
- Jonas JB, Söfker A. Intraocular injection of crystalline cortisone as adjunctive treatment of diabetic macular edema. *Am J Ophthalmol.* 2001;132(3):425–7.
- Jonas JB, Kampeter BA, Harder B, Vossmerbaeumer U, Sauder G, Spandau UHM. Intravitreal triamcinolone acetonide for diabetic macular edema: a prospective, randomized study. *J Ocul Pharmacol Ther.* 2006a;22(3):200–7.
- Jonas JB, Kreissig I, Spandau UH, Harder B. Infectious and noninfectious endophthalmitis after intravitreal high-dosage triamcinolone acetonide. *Am J Ophthalmol.* 2006b;141(3):579–80.
- Juen S, Kieselbach GF. Electrophysiological changes in juvenile diabetics without retinopathy. *Arch Ophthalmol (Chicago, 1960).* 1990;108(3):372–5.
- Kang SW, Park CY, Ham D-I. The correlation between fluorescein angiographic and optical coherence tomographic features in clinically significant diabetic macular edema. *Am J Ophthalmol.* 2004;137(2):313–22.
- Keech AC, Mitchell P, Summanen PA, O'Day J, Davis TME, Moffitt MS, et al. Effect of fenofibrate on the need for laser treatment for diabetic retinopathy (FIELD study): a randomised controlled trial. *Lancet.* 2007;370(9600):1687–97.
- Kim BY, Smith SD, Kaiser PK. Optical coherence tomographic patterns of diabetic macular edema. *Am J Ophthalmol.* 2006;142(3):405–12.
- Klein R, Klein BE, Moss SE, Davis MD, DeMets DL. The Wisconsin epidemiologic study of diabetic retinopathy. II. Prevalence and risk of diabetic retinopathy when age at diagnosis is less than 30 years. *Arch Ophthalmol (Chicago, 1960).* 1984a;102(4):520–6.
- Klein R, Klein BE, Moss SE, DeMets DL, Kaufman I, Voss PS. Prevalence of diabetes mellitus in southern Wisconsin. *Am J Epidemiol.* 1984b;119(1):54–61.
- Klein R, Klein BE, Neider MW, Hubbard LD, Meuer SM, Brothers RJ. Diabetic retinopathy as detected using ophthalmoscopy, a nonmydriatic camera and a standard fundus camera. *Ophthalmology.* 1985;92(4):485–91.
- Klein R, Meuer SM, Moss SE, Klein BE. The relationship of retinal microaneurysm counts to the 4-year progression of diabetic retinopathy. *Arch Ophthalmol (Chicago, 1960).* 1989;107(12):1780–5.
- Klein R, Klein BE, Moss SE, Linton KL. The Beaver Dam Eye Study. Retinopathy in adults with newly discovered and previously diagnosed diabetes mellitus. *Ophthalmology.* 1992;99(1):58–62.
- Klein R, Klein BE, Moss SE, Cruickshanks KJ. The Wisconsin Epidemiologic Study of Diabetic Retinopathy. XV. The long-term incidence of macular edema. *Ophthalmology.* 1995;102(1):7–16.

- Klein R, Knudtson MD, Lee KE, Gangnon R, Klein BEK. The Wisconsin Epidemiologic Study of Diabetic Retinopathy: XXII the twenty-five-year progression of retinopathy in persons with type 1 diabetes. *Ophthalmology*. 2008;115(11):1859–68.
- Kohner EM, Henkind P. Correlation of fluorescein angiogram and retinal digest in diabetic retinopathy. *Am J Ophthalmol*. 1970;69(3):403–14.
- Kohner EM, Stratton IM, Aldington SJ, Turner RC, Matthews DR. Microaneurysms in the development of diabetic retinopathy (UKPDS 42). UK Prospective Diabetes Study Group. *Diabetologia*. 1999;42(9):1107–12.
- Koya D, King GL. Protein kinase C activation and the development of diabetic complications. *Diabetes*. 1998;47(6):859–66.
- Kralinger MT, Pedri M, Kralinger F, Troger J, Kieselbach GF. Long-term outcome after vitrectomy for diabetic macular edema. *Int J Ophthalmol*. 2006;220(3):147–52.
- Kreines K, Rowe KW. Cataracts and adult diabetes. *Ohio State Med J*. 1979;75(12):782–785–6.
- Krikorian A. Standards of medical care in diabetes 2016. *Diabetes Care*. 2016;39(Suppl 1):S1–112.
- Kuppermann BD, Blumenkranz MS, Haller JA, Williams GA, Group PS. An intravitreal dexamethasone bioerodible drug delivery system for the treatment of persistent diabetic macular edema. *Invest Ophthalmol Vis Sci*. 2003;44(13):4289.
- L'Esperance FAJW. *Diabetic retinopathy, clinical evaluation and management*. St. Louis: Mosby; 1981.
- La Heij EC, Hendrikse F, Kessels AG, Derhaag PJ. Vitrectomy results in diabetic macular oedema without evident vitreomacular traction. *Graefes Arch Clin Exp Ophthalmol*. 2001;239(4):264–70.
- Lang GE. Optical coherence tomography findings in diabetic retinopathy. *Dev Ophthalmol*. 2007;39:31–47.
- Laws HW, Harpur ER. Lipemia retinalis; report of a case in a diabetic child aged twenty-eight months and review of the literature. *AMA Arch Ophthalmol*. 1958;59(4):521–6.
- Lee PP, Feldman ZW, Ostermann J, Brown DS, Sloan FA. Longitudinal rates of annual eye examinations of persons with diabetes and chronic eye diseases. *Ophthalmology*. 2003;110(10):1952–9.
- Leopold IH, Mosier MA. Four common ocular complications of diabetes – and how to treat them. *Geriatrics*. 1978;33(11):33–41.
- Leske MC, Wu S-Y, Nemesure B, Hennis A. Causes of visual loss and their risk factors: an incidence summary from the Barbados Eye Studies. *Rev Panam Salud Pública*. 2010;27(4):259–67.
- Liew G, Michaelides M, Bunce C. A comparison of the causes of blindness certifications in England and Wales in working age adults (16–64 years), 1999–2000 with 2009–2010. *BMJ Open*. 2014;4(2):e004015.
- Little HL, Rosenthal AR, Dellaporta A, Jacobson DR. The effect of pan-retinal photo-coagulation on rubeosis iridis. *Am J Ophthalmol*. 1976;81(6):804–9.
- Lubow M, Makley TA. Pseudopapilledema of juvenile diabetes mellitus. *Arch Ophthalmol (Chicago, 1960)*. 1971;85(4):417–22.
- Madsen PH. Rubeosis of the iris and haemorrhagic glaucoma in patients with proliferative diabetic retinopathy. *Br J Ophthalmol*. 1971;55(6):368–71.
- Mannucci E, Monami M, Dicembrini I, Piselli A, Porta M. Achieving HbA1c targets in clinical trials and in the real world: a systematic review and meta-analysis. *J Endocrinol Investig*. 2014;37(5):477–95.
- Margolis R, Kaiser PK. Diagnostic modalities in diabetic retinopathy. In: Duh EJ, editor. *Diabetic retinopathy*. Totowa: Humana Press; 2008. p. 109–33.
- Martidis A, Duker JS, Greenberg PB, Rogers AH, Puliafito CA, Reichel E, et al. Intravitreal triamcinolone for refractory diabetic macular edema. *Ophthalmology*. 2002;109(5):920–7.
- Massin P, Audren F, Haouchine B, Erginay A, Bergmann J-F, Benosman R, et al. Intravitreal triamcinolone acetonide for diabetic diffuse macular edema: preliminary results of a prospective controlled trial. *Ophthalmology*. 2004;111(2):218–24-5.

- Massin P, Girach A, Erginay A, Gaudric A. Optical coherence tomography: a key to the future management of patients with diabetic macular oedema. *Acta Ophthalmol Scand.* 2006;84(4):466–74.
- Massin P, Bandello F, Garweg JG, Hansen LL, Harding SP, Larsen M, et al. Safety and efficacy of ranibizumab in diabetic macular edema (RESOLVE Study): a 12-month, randomized, controlled, double-masked, multicenter phase II study. *Diabetes Care.* 2010;33(11):2399–405.
- Mauer M, Zinman B, Gardiner R, Suissa S, Sinaiko A, Strand T, et al. Renal and retinal effects of enalapril and losartan in type 1 diabetes. *N Engl J Med.* 2009;361(1):40–51.
- Mitchell P, Bandello F, Schmidt-Erfurth U, Lang GE, Massin P, Schlingemann RO, et al. The RESTORE study: ranibizumab monotherapy or combined with laser versus laser monotherapy for diabetic macular edema. *Ophthalmology.* 2011;118(4):615–25.
- Morgan CM, Schatz H. Atrophic creep of the retinal pigment epithelium after focal macular photocoagulation. *Ophthalmology.* 1989;96(1):96–103.
- Morse PH. Ocular symptoms and signs of diabetes. *Geriatrics.* 1976;31(10):59–63.
- Moss SE, Klein R, Kessler SD, Richie KA. Comparison between ophthalmoscopy and fundus photography in determining severity of diabetic retinopathy. *Ophthalmology.* 1985;92(1):62–7.
- National Eye Institute. Five year follow-up data release [Early Treatment Diabetic Retinopathy Study]. Press Release, 9 Mar 1993. 1993. <http://www.nei.nih.gov/news/pressreleases/030993.asp>
- Network TDRCR. Aflibercept, bevacizumab, or ranibizumab for diabetic macular edema. *N Engl J Med.* 2015;372(13):1193–203.
- Nishikawa T, Edelstein D, Du XL, Yamagishi S, Matsumura T, Kaneda Y, et al. Normalizing mitochondrial superoxide production blocks three pathways of hyperglycaemic damage. *Nature.* 2000;404(6779):787–90.
- Nunes S, Pires I, Rosa A, Duarte L, Bernardes R, Cunha-Vaz J. Microaneurysm turnover is a biomarker for diabetic retinopathy progression to clinically significant macular edema: findings for type 2 diabetics with nonproliferative retinopathy. *Int J Ophthalmol.* 2009;223(5):292–7.
- Ogle J St. George's hospital report, vol. 1. 1866. p. 177. London: John Churchill and Sons.
- Ohr M, Kaiser PK. Intravitreal aflibercept injection for neovascular (wet) age-related macular degeneration. *Expert Opin Pharmacother.* 2012;13(4):585–91.
- Oliveira CM, Cristóvão LM, Ribeiro ML, Abreu JRF. Improved automated screening of diabetic retinopathy. *Int J Ophthalmol.* 2011;226(4):191–7.
- Otani T, Kishi S, Maruyama Y. Patterns of diabetic macular edema with optical coherence tomography. *Am J Ophthalmol.* 1999;127(6):688–93.
- Owens DR, Gibbins RL, Lewis PA, Wall S, Allen JC, Morton R. Screening for diabetic retinopathy by general practitioners: ophthalmoscopy or retinal photography as 35 mm colour transparencies? *Diabet Med.* 1998;15(2):170–5.
- Palmowski AM, Sutter EE, Bearse MA, Fung W. Mapping of retinal function in diabetic retinopathy using the multifocal electroretinogram. *Invest Ophthalmol Vis Sci.* 1997;38(12):2586–96.
- Panozzo G, Gusson E, Parolini B, Mercanti A. Role of OCT in the diagnosis and follow up of diabetic macular edema. *Semin Ophthalmol.* 2003;18(2):74–81.
- Patel A, MacMahon S, Chalmers J, Neal B, Woodward M, Billot L, et al. Effects of a fixed combination of perindopril and indapamide on macrovascular and microvascular outcomes in patients with type 2 diabetes mellitus (the ADVANCE trial): a randomised controlled trial. *Lancet.* 2007;370(9590):829–40.
- Pircher M, Göttinger E, Findl O, Michels S, Geitzenauer W, Leydolt C, et al. Human macula investigated in vivo with polarization-sensitive optical coherence tomography. *Invest Ophthalmol Vis Sci.* 2006;47(12):5487–94.
- Plu G, Lecrubier C, Scarabin PY, Baudoin C, Samama M. Does increased platelet aggregation have a prognostic value in the deterioration of background diabetic retinopathy? The Damad Study Group. *Thromb Haemost.* 1990;64(2):202–5.
- Porta M, Bandello F. Diabetic retinopathy a clinical update. *Diabetologia.* 2002;45(12):1617–34.
- Porta M, Toppila I, Sandholm N, Hosseini SM, Forsblom C, Hietala K, et al. Variation in SLC19A3 and protection from microvascular damage in type 1 diabetes. *Diabetes.* 2015;65(12):1022–1030.

- Ribeiro L, Oliveira CM, Neves C, Ramos JD, Ferreira H, Cunha-Vaz J. Screening for diabetic retinopathy in the Central Region of Portugal. Added value of automated “disease/no disease” grading. *Ophthalmologica*. 2014;233(2):96–103.
- Rosenfeld PJ. Intravitreal avastin: the low cost alternative to lucentis? *Am J Ophthalmol*. 2006;142(1):141–3.
- Scanlon PH. The English national screening programme for sight-threatening diabetic retinopathy. *J Med Screen*. 2008;15(1):1–4.
- Scholl HP, Zrenner E. Electrophysiology in the investigation of acquired retinal disorders. *Surv Ophthalmol*. 2000;45(1):29–47.
- Schwartz DE. Corneal sensitivity in diabetics. *Arch Ophthalmol (Chicago, 1960)*. 1974;91(3):174–8.
- Scullica L, Proto F. Clinical and statistical findings on corneal sensitivity in diabetics. *Boll Ocul*. 1965;44(12):944–54.
- Shakib M, Cunha-Vaz JG. Studies on the permeability of the blood-retinal barrier. IV. Junctional complexes of the retinal vessels and their role in the permeability of the blood-retinal barrier. *Exp Eye Res*. 1966;5(3):229–34.
- Shirao Y, Kawasaki K. Electrical responses from diabetic retina. *Prog Retin Eye Res*. 1998;17(1):59–76.
- Silva PS, Horton MB, Clary D, Lewis DG, Sun JK, Cavallerano JD, et al. Identification of diabetic retinopathy and ungradable image rate with ultrawide field imaging in a National Tele-ophthalmology Program. *Ophthalmology*. 2016;123(6):1360–7.
- Simmons RJ, Dueker DK, Kimbrough RL, Aiello LM. Goniophotocoagulation for neovascular glaucoma. *Trans Sect Ophthalmol Am Acad Ophthalmol Otolaryngol*. 1977;83(1):80–9.
- Singh R, Abhiramamurthy V, Gupta V, Gupta A, Bhansali A. Effect of multifactorial intervention on diabetic macular edema. *Diabetes Care*. 2006;29(2):463–4.
- Siu SC, Ko TC, Wong KW, Chan WN. Effectiveness of non-mydratric retinal photography and direct ophthalmoscopy in detecting diabetic retinopathy. *Hong Kong Med J*. 1998;4(4):367–70.
- Sjøløe AK, Klein R, Porta M, Orchard T, Fuller J, Parving HH, et al. Effect of candesartan on progression and regression of retinopathy in type 2 diabetes (DIRECT-protect 2): a randomised placebo-controlled trial. *Lancet*. 2008;372(9647):1385–93.
- Sjøløe AK, Klein R, Porta M, Orchard T, Fuller J, Parving HH, et al. Retinal microaneurysm count predicts progression and regression of diabetic retinopathy. Post-hoc results from the DIRECT Programme. *Diabet Med*. 2011;28(3):345–51.
- Smith JL. Asteroid hyalitis and diabetes mellitus. *Trans Am Acad Ophthalmol Otolaryngol*. 1965;69:269–77.
- Smith ME, Glickman P. Diabetic vacuolation of the iris pigment epithelium. *Am J Ophthalmol*. 1975;79(5):875–7.
- Sobrin L, D’Amico DJ. Controversies in intravitreal triamcinolone acetonide use. *Int Ophthalmol Clin*. 2005;45(4):133–41.
- Spaide RF, Fisher YL. Intravitreal bevacizumab (Avastin) treatment of proliferative diabetic retinopathy complicated by vitreous hemorrhage. *Retina*. 2006;26(3):275–8.
- Spandau UHM, Derse M, Schmitz-Valckenberg P, Papoulis C, Jonas JB. Dosage dependency of intravitreal triamcinolone acetonide as treatment for diabetic macular oedema. *Br J Ophthalmol*. 2005;89(8):999–1003.
- Stefánsson E, Bek T, Porta M, Larsen N, Kristinsson JK, Agardh E. Screening and prevention of diabetic blindness. *Acta Ophthalmol Scand*. 2000;78(4):374–85.
- Stewart MW. Anti-vascular endothelial growth factor drug treatment of diabetic macular edema: the evolution continues. *Curr Diabetes Rev*. 2012;8(4):237–46.
- Sutter EE, Tran D. The field topography of ERG components in man – I. The photopic luminance response. *Vis Res*. 1992;32(3):433–46.
- The DAMAD Study Group. Effect of aspirin alone and aspirin plus dipyridamole in early diabetic retinopathy. A multicenter randomized controlled clinical trial. The DAMAD Study Group. *Diabetes*. 1989;38(4):491–8.

- The Diabetes Control and Complications Trial Research Group. The effect of intensive treatment of diabetes on the development and progression of long-term complications in insulin-dependent diabetes mellitus. The Diabetes Control and Complications Trial Research Group. *N Engl J Med.* 1993;329(14):977–86.
- The Diabetes Control and Complications Trial Research Group. Lifetime benefits and costs of intensive therapy as practiced in the diabetes control and complications trial. The Diabetes Control and Complications Trial Research Group. *JAMA.* 1996;276(17):1409–15.
- The Diabetes Control and Complications Trial/Epidemiology of Diabetes Interventions and Complications (DCCT/EDIC) Research Group. Modern-day clinical course of type 1 diabetes mellitus after 30 years' duration: the diabetes control and complications trial/epidemiology of diabetes control and complications trial trial/epidemiology of diabetes interventions and complications and Pittsburgh epidemiology of diabetes complications experience (1983–2005). *Arch Intern Med.* 2009;169(14):1307–16.
- The Diabetic Retinopathy Study Research Group. Photocoagulation treatment of proliferative diabetic retinopathy. Clinical application of Diabetic Retinopathy Study (DRS) findings, DRS report number 8. The Diabetic Retinopathy Study Research Group. *Ophthalmology.* 1981;88(7):583–600.
- The Diabetic Retinopathy Vitrectomy Study Research Group. Early vitrectomy for severe vitreous hemorrhage in diabetic retinopathy. Two-year results of a randomized trial. Diabetic Retinopathy Vitrectomy Study report 2. The Diabetic Retinopathy Vitrectomy Study Research Group. *Arch Ophthalmol (Chicago, 1960).* 1985;103(11):1644–52.
- The TIMAD Study Group. Ticlopidine treatment reduces the progression of nonproliferative diabetic retinopathy. The TIMAD Study Group. *Arch Ophthalmol (Chicago, 1960).* 1990;108(11):1577–83.
- Thomas RL, Dunstan FD, Luzio SD, Chowdhury SR, North RV, Hale SL, et al. Prevalence of diabetic retinopathy within a national diabetic retinopathy screening service. *Br J Ophthalmol.* 2015;99(1):64–8.
- Torrent-Solans T, Duarte L, Monteiro R, Almeida E, Bernardes R, Cunha-Vaz J. Red dots counting on digitalized fundus images of mild nonproliferative retinopathy in diabetes type 2. *Invest Ophthalmol Vis Sci.* 2004;45(13):2985.
- Tremolada G, Del Turco C, Lattanzio R, Maestroni S, Maestroni A, Bandello F, et al. The role of angiogenesis in the development of proliferative diabetic retinopathy: impact of intravitreal anti-VEGF treatment. *Exp Diabetes Res.* 2012;2012:728325.
- Tzekov R, Arden GB. The electroretinogram in diabetic retinopathy. *Surv Ophthalmol.* 1999;44(1):53–60.
- UK Prospective Diabetes Study (UKPDS) Group. Intensive blood-glucose control with sulphonylureas or insulin compared with conventional treatment and risk of complications in patients with type 2 diabetes (UKPDS 33). UK Prospective Diabetes Study (UKPDS) Group. *Lancet.* 1998a;352(9131):837–53.
- UK Prospective Diabetes Study (UKPDS) Group. Tight blood pressure control and risk of macrovascular and microvascular complications in type 2 diabetes: UKPDS 38. UK Prospective Diabetes Study Group. *BMJ.* 1998b;317(7160):703–13.
- Vander JF, Duker JS, Benson WE, Brown GC, McNamara JA, Rosenstein RB. Long-term stability and visual outcome after favorable initial response of proliferative diabetic retinopathy to panretinal photocoagulation. *Ophthalmology.* 1991;98(10):1575–9.
- Varma R, Mohanty SA, Deneen J, Wu J, Azen SP. Burden and predictors of undetected eye disease in Mexican-Americans: the Los Angeles Latino Eye Study. *Med Care.* 2008;46(5):497–506.
- Wachtmeister L, Dowling JE. The oscillatory potentials of the mudpuppy retina. *Invest Ophthalmol Vis Sci.* 1978;17(12):1176–88.
- Waisbourd M, Goldstein M, Loewenstein A. Treatment of diabetic retinopathy with anti-VEGF drugs. *Acta Ophthalmol.* 2011;89(3):203–7.
- Waite JH, Beetham WP. The visual mechanism in diabetes mellitus. *N Engl J Med.* 1935;212(9):367–79.

- Waltman S, Krupin T, Hanish S, Oestrich C, Becker B. Alteration of the blood-retinal barrier in experimental diabetes mellitus. *Arch Ophthalmol (Chicago, 1960)*. 1978a;96(5):878–9.
- Waltman SR, Oestrich C, Krupin T, Hanish S, Ratzan S, Santiago J, et al. Quantitative vitreous fluorophotometry. A sensitive technique for measuring early breakdown of the blood-retinal barrier in young diabetic patients. *Diabetes*. 1978b;27(2):85–7.
- Williams GA, Scott IU, Haller JA, Maguire AM, Marcus D, McDonald HR. Single-field fundus photography for diabetic retinopathy screening: a report by the American Academy of Ophthalmology. *Ophthalmology*. 2004;111(5):1055–62.
- Williamson JR, Chang K, Frangos M, Hasan KS, Ido Y, Kawamura T, et al. Hyperglycemic pseudohypoxia and diabetic complications. *Diabetes*. 1993;42(6):801–13.
- Wilson PJ, Ellis JD, MacEwen CJ, Ellingford A, Talbot J, Leese GP. Screening for diabetic retinopathy: a comparative trial of photography and scanning laser ophthalmoscopy. *Int J Ophthalmol*. 2010;224(4):251–7.
- Wolfram DJWH. Diabetes mellitus and simple optic atrophy among sibilings: report of four cases. *Mayo Clin Proc*. 1938;13:715–8.
- World Health Organization. 2001. Principles of Screening. World Health Organization. Geneva.
- Wright AD, Dodson PM. Medical management of diabetic retinopathy: fenofibrate and ACCORD Eye Studies. *Eye*. 2011;25(7):843–9.
- Yamamoto S, Yamamoto T, Hayashi M, Takeuchi S. Morphological and functional analyses of diabetic macular edema by optical coherence tomography and multifocal electroretinograms. *Graefes Arch Clin Exp Ophthalmol*. 2001;239(2):96–101.
- Yamashita T, Becker B. The basement membrane in the human diabetic eye. *Diabetes*. 1961;10:167–74.
- Yang CM. Surgical treatment for severe diabetic macular edema with massive hard exudates. *Retina*. 2000;20(2):121–5.
- Yang CS, Cheng CY, Lee FL, Hsu WM, Liu JH. Quantitative assessment of retinal thickness in diabetic patients with and without clinically significant macular edema using optical coherence tomography. *Acta Ophthalmol Scand*. 2001;79(3):266–70.
- Yannuzzi LA, Rohrer KT, Tindell LJ, Sobel RS, Costanza MA, Shields W, et al. Fluorescein angiography complication survey. *Ophthalmology*. 1986;93(5):611–7.
- Yanoff M, Fine BS, Berkow JW. Diabetic lacy vacuolation of iris pigment epithelium; a histopathologic report. *Am J Ophthalmol*. 1970;69(2):201–10.
- Yau JWY, Rogers SL, Kawasaki R, Lamoureux EL, Kowalski JW, Bek T, et al. Global prevalence and major risk factors of diabetic retinopathy. *Diabetes Care*. 2012;35(3):556–64.
- Yonemura D, Masuda Y, Hatta M. The oscillatory potential in the electroretinogram. *Jpn J Physiol*. 1963;13:129–37.
- Zhang L, Krzentowski G, Albert A, Lefebvre PJ. Risk of developing retinopathy in Diabetes Control and Complications Trial type 1 diabetic patients with good or poor metabolic control. *Diabetes Care*. 2001;24(7):1275–9.



# Diabetes and the Nervous System

# 9

Aaron I. Vinik, Carolina Casellini, and Serina Neumann

## Contents

Introduction and Scope of the Problem .....	276
Central Nervous System and Diabetes .....	277
Structural Changes .....	277
Functional Changes .....	278
Epidemiologic Evidence of CNS Dysfunction in DM .....	279
Mechanisms of CNS Changes in Diabetes .....	279
Cognition and Behavior .....	282
Peripheral Nervous System and Diabetes .....	283
Pathogenesis of Diabetic Neuropathies .....	284
Classification of Diabetic Neuropathies .....	285
Clinical Presentation .....	286
Focal and Multifocal Neuropathies .....	286
Radiculopathies or Polyradiculopathies .....	288
Acute Painful Treatment-Induced Neuropathy .....	289
Distal Symmetric Polyneuropathy (DSPN) .....	289
Screening and Diagnosis of Diabetic Neuropathies .....	295
Toronto Classification of DSPN (Teschfaye et al. 2010) .....	295
Clinical Assessment of DSPN .....	296

---

A. I. Vinik (✉) · C. Casellini  
Strelitz Diabetes Center and The Neuroendocrine Unit, Eastern Virginia Medical School, Norfolk,  
VA, USA  
e-mail: [vinikai@evms.edu](mailto:vinikai@evms.edu); [casellcm@evms.edu](mailto:casellcm@evms.edu)

S. Neumann  
Psychiatry and Behavioral Sciences/Behavioral Medicine Program/Therapeutic Brain Stimulation  
Program, Eastern Virginia Medical School, Norfolk, VA, USA  
e-mail: [neumansa@evms.edu](mailto:neumansa@evms.edu)

Conditions Mimicking Diabetic Neuropathy .....	299
Objective Devices for the Diagnosis of Neuropathy .....	300
Cardiac Autonomic Neuropathy .....	305
Treatment of Diabetic Polyneuropathies .....	307
Treatment of Specific Underlying Pathogenic Mechanisms .....	307
Treatment of Symptoms and Improvement in QoL .....	310
References .....	330

---

## Abstract

Diabetic neuropathy is the most common and troublesome complication of diabetes mellitus, leading to the greatest morbidity and mortality and resulting in a huge economic burden for diabetes care. It includes a set of clinical syndromes that affect distinct regions of the nervous system, singly or combined. Current research shows that diabetes can affect brain structure and function and lead to significant changes in cognition and behavior. Peripheral neuropathy may be silent and go undetected or it may present with clinical symptoms and signs including pain that can significantly affect the patients' quality of life. It also contributes to additional risks in the aging adult. Loss of sensory perception and muscle strength, and ataxia or incoordination, leads to an increased risk of falling in the elderly. However, risk factors for falling are not simply confined to those variables associated with peripheral sensory-motor function. Cognitive decline, particularly related to executive functioning, is a contributing factor to instability. Cardiac autonomic neuropathy is a common complication of diabetes. Early diagnosis is key, as it has been shown to be an independent risk factor for cardiovascular mortality, arrhythmias, major cardiovascular event, and myocardial dysfunction. This Chapter will describe our current knowledge on central, peripheral, and autonomic nervous system alterations in response to prediabetes and type 1 and type 2 diabetes.

---

## Keywords

Diabetes · Diabetic peripheral neuropathy · Pain · Cardiac autonomic neuropathy · Cognitive dysfunction · Central nervous system

---

## Introduction and Scope of the Problem

Given that it is fairly common for patients with diabetes mellitus (DM) to show problematic changes in cognition and behavior, numerous investigations have ensued to uncover multiple alterations in brain function. Moreover, researchers are diligently working to gain a better understanding of the risk factors and mechanisms responsible for these changes in order to guide prevention and treatment (Fig. 1). This Chapter will provide current and empirically supported information known about central and peripheral nervous system alterations in response to prediabetes and type 1 and type 2 diabetes mellitus (T1DM and T2DM, respectively).



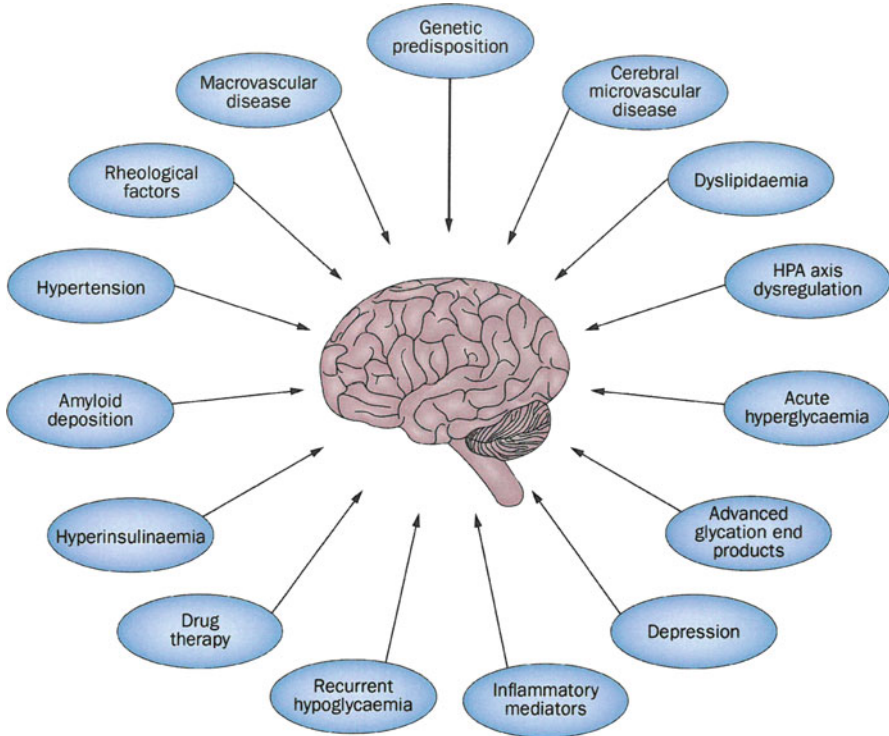

**Fig. 1** Numerous potential mediators of cognitive impairment in patients with diabetes. *HPA* hypothalamicpituitary-adrenal axis. (Strachan and Price 2014. Reprinted by permission from Springer Nature)

## Central Nervous System and Diabetes

### Structural Changes

Global and specific brain alterations have been discovered with the use of neuroimaging and postmortem studies. Cerebral infarcts (silent), cortical and subcortical atrophy, and changes in electrophysiological properties have been noted. Age, duration of disease, and glucose regulation have been found to influence the severity of these structural changes.

Cerebral atrophy and periventricular, subcortical white matter abnormalities tend to develop over time in patients with diabetes (Fig. 2) (de Bresser et al. 2010; van Elderen et al. 2010). Gray matter loss has been found in the frontal and temporal lobes, hippocampus, and anterior cingulate cortex; white matter loss has been noted in both the frontal and temporal lobes as well (Sato and Morishita 2014).

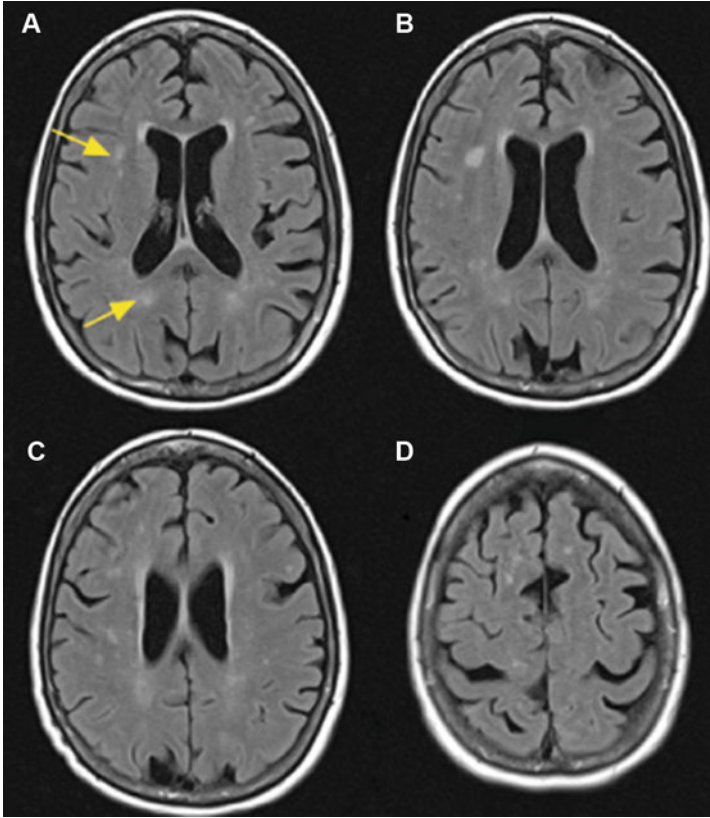

**Fig. 2** Magnetic resonance imaging (MRI) of the brain from a 62-year-old woman with type 2 diabetes mellitus for 12 years, who presented with mild ataxia of gait and polyneuropathy. Axial T2-weighted fluid-attenuated inversion recovery (FLAIR) sequences progress from caudal to rostral cuts (**a–d**) and show non-enhancing bilateral white matter hyperintensities (arrows in **a**), also termed diabetic leukoencephalopathy

## Functional Changes

Using fMRI measures at rest in patients with DM, abnormal functional activity has been measured between the posterior cingulate cortex and medial frontal/temporal gyrus highlighting white matter abnormalities (Sato and Morishita 2014; Chen et al. 2014). In addition, decreased neural activity has been seen in the occipital lobe and postcentral gyrus which correlated with decreased cognitive function (Sato and Morishita 2014; Cui et al. 2014). During standardized cognitive tasks, fMRI measures have shown reduced dorsolateral prefrontal cortex encoding in patients with DM in comparison to relatively healthy individuals without DM. Some MRI studies show that ischemic white matter lesions are associated with cognitive dysfunction, depression, and gait disturbance (Sabri et al. 1999; Mathews et al. 1995). These fMRI

findings demonstrate that neural activity anomalies likely influence cognitive dysfunction and parallel the evidence from neuropsychological studies reviewed below showing specific cognitive deficits in patients with DM.

## **Epidemiologic Evidence of CNS Dysfunction in DM**

Diabetes has been shown to be a risk factor for mild cognitive impairment and dementia (Luchsinger et al. 2001). Hyperinsulinemia may be one factor increasing this risk (Luchsinger et al. 2004). Several studies have shown a significant correlation between poor glycemic control and longer disease duration with worse cognitive function and greater cognitive decline, suggesting that the severity of T2DM contributes in some way to cognitive aging beyond what is found in individuals without DM (Yaffe et al. 2012; Geijselaers et al. 2015). These findings of gradual changes in cognitive function are in concurrence with the trajectory of structural changes seen in patients with DM discussed above. Epidemiologic studies indicate that diabetes is an independent risk factor for cognitive impairment, and the frequency of diabetes and cognitive dysfunction increases with age (van den Berg et al. 2006; Allen et al. 2004; Stewart and Liolitsa 1999). Community-based studies in different populations, including the Hisayama, the Canadian Health and Aging, and the Rotterdam cohorts, showed an increase of vascular dementia and Alzheimer's disease in DM (Ott et al. 1996; Lindsay et al. 1997; Yoshitake et al. 1995). The exact mechanism of this association is not clear. It seems this is not a function of hyperglycemia alone but is also related to obesity, insulin resistance, and elevated triglycerides (Ott et al. 1996; Gustafson 2006). The next section describes in more detail the potential mechanisms underlying the gradual structural and functional changes seen in the brain over time.

## **Mechanisms of CNS Changes in Diabetes**

Previous research has shown that diabetes often deleteriously impact brain structure and function above and beyond the brain of individuals without diabetes with varying degrees of supporting evidence. It is not quite clear what precise mechanisms are involved in this complex process, and it seems to be multifactorial (Fig. 1). Mechanisms shown to influence accelerated brain aging (structure and function) in relation to diabetes include decreases in insulin activity, impaired glucose homeostasis, dysregulation of hypothalamic-pituitary-adrenal (HPA) axis function, and hyperleptinemia, among others (Bordier et al. 2014; Strachan and Price 2014). The hippocampi are affected by these pathogenic mechanisms causing dendritic atrophy, changes in synapse formation, electrophysiological deficits, as well as the appearance of Alzheimer's disease-like histopathology, such as hyperphosphorylated tau (Strachan and Price 2014). These mechanisms in combination with microvascular insufficiency and proinflammatory cytokines such as interleukin-6 (IL-6), tumor necrosis factor- $\alpha$  (TNF- $\alpha$ ), and nuclear factor kappa B (NF $\kappa$ B) are responsible at least in part for the cognitive deficits often seen in patients

with DM (Gustafson 2006). Thus far, the majority of the evidence points toward poor glycemic control and glucose variability as being major risk factors related to lower cognitive function in people with T2DM without dementia (Geijselaers et al. 2015; Punthakee et al. 2012), and several studies have been conducted to evaluate whether this cognitive decline could be reversible with a better glycemic control (Ryan et al. 2006; Cukierman-Yaffe et al. 2009). It has been proposed that mood changes and poor memory function derived from hypo- and/or hyperinsulinemia may cause alterations in cerebral blood flow. Osmotic changes in neurons as a consequence of chronic hyperglycemia might also cause cerebral microvascular disease (Kloppenborg et al. 2008; Samaras and Sachdev 2012; Strachan 2011). Both Rotterdam and Framingham studies attribute dementia to the use of insulin (Ott et al. 1996; Elias et al. 1997). Insulin receptors are expressed in both the hippocampi and cerebral cortex (Havrankova et al. 1978; Hill et al. 1986; Banks 2004; Molnar et al. 2014). In the brain of patients with DM, insulin signaling is decreased (Sato and Morishita 2014). Also noted is that *insulin signaling* influences neuronal aging (Bordier et al. 2014; Cohen and Dillin 2008). In this regard, hyperinsulinemia is found to downregulate insulin signaling pathways and inactivate glycogen synthase kinase 3 in the brain, enhancing tau hyperphosphorylation (Francis et al. 2008; Cross et al. 1995; Park 2001). In small-scale studies, intranasal insulin administration improved cognitive deficits in humans with AD (Francis et al. 2008; Benedict et al. 2007; Craft et al. 2012; Shemesh et al. 2012).

The effects of metabolic changes in the brain that are shared by diabetes may also underlie increased risk for Alzheimer's disease (AD). There is evidence of some interaction between *diabetic leukoencephalopathy* and AD in *apolipoprotein processing*, *corticosteroid dysregulation*, and insulin signaling disturbances (Stranahan et al. 2008; Zhao and Townsend 2009). The structure of amylin found in the beta cells of patients with T2DM is similar to the best amyloid found in the neuronal plaques of AD (Cooper et al. 1988), and polymorphism in certain genes is found in both diabetic neuropathy (DN) and AD. There is additional toxicity due to oxidative stress and reduced nitric oxide bioavailability due to propagation of glycation end products that occur during aging and diabetes (Brownlee 2005). Both advanced glycation end products (AGEs) and A1c have been incriminated in brain atrophy (Enzinger et al. 2005). AGEs, which include molecules in the hyperglycemic pathway but also products of lipid and LDLc oxidation, have been impugned in cognitive decline. AGEs have been found in the neurofibrillary tangles contributing to plaque formation and neuronal loss in AD (Dore et al. 1997; Takeda et al. 2001). Additionally, there is *upregulation of RAGE (AGE receptor)*, a ubiquitous multi-ligand transmembrane receptor of the immunoglobulin superfamily of cell surface molecules (Brownlee 2005; Wautier and Guillausseau 2001). Glycation and oxidation with binding of AGEs to RAGE (Finch and Cohen 1997; Renard et al. 1997; Yan et al. 1997) as well as the binding of  $\beta$ -amyloid to the RAGE receptor may also contribute to AD (Yan et al. 1997). Of great interest are a new cadre of agents that can compete with AGEs binding to RAGE, mitigating the effect of AGEs (Vinik 2012). Signaling through this pathway initiates protein kinases including *pro-inflammatory gene activation* and secondary immune responses (Yan et al. 2009).

*Nuclear factor  $\kappa$ B*, a central transcription factor targeted by RAGE signaling, may be contributing to diabetic leukoencephalopathy (Bierhaus et al. 2001; Perkins 2000; Baeuerle and Baltimore 1996; Frolich et al. 1998). Abnormally high RAGE expression occurs in animal models of diabetes within gray matter, as well as in white matter regions (Toth et al. 2006). The extreme form of neuropathy is Charcot's neuroarthropathy which is associated with deposition of AGEs in the collagen of the Achilles tendon, leading to destruction of collagen and bone fractures (Grant et al. 1997). The usual defense is the secretion of a soluble RAGE which binds to RAGE acting as a decoy molecule competing with other AGEs for RAGE receptor activation (Witzke and Vinik 2012). Witzke and colleagues reported a reduction of circulating sRAGE by 50% in subjects with diabetes and 85% in subjects with Charcot's neuroarthropathy (Witzke and Vinik 2012; Witzke et al. 2011). Theoretically the potential for developing a gene therapy to correct this defect may have potential for improving Alzheimer's disease, neuropathy, and cognitive decline.

The loss of neurons and atrophy seen in DM is not confined to the brain but also impacts the spinal cord. Using MR imaging, a reduction in the cross-sectional area of the cervical cord was detected in the presence of severe neuropathy (Eaton et al. 2001). In a later report, it was shown that atrophy occurred before the advent of severe neuropathy. More recent studies have reported on the reduction of spinal cord volume in subclinical neuropathy (Selvarajah et al. 2006). MR spectroscopy may give support to the role of diabetes (Cameron et al. 2005), hypoglycemia (Criego et al. 2005), and ketoacidosis (Wootton-Gorges et al. 2005) on spinal atrophy. Clearly the question arises as to the functional significance of these observations, and Selvarajah and colleagues have elegantly demonstrated thalamic sensory neuronal dysfunction (Selvarajah et al. 2004) in association with neuropathy. Furthermore, using PET scanning, it has now been shown that there is activation of the amygdala that precedes the onset of sympathetic nerve activation and a cascade influencing an inflammatory response in blood vessels predicting major adverse cardiovascular events. Thus, rather than the corollary, it appears that the brain may be the leader of the orchestra, and its dysfunction leading to dire consequences mediated peripherally via the autonomic nervous system (Vinik et al. 2010a, 2011).

Research has also focused on *hypoglycemia* and its effects on the brain, as brain metabolism relies exclusively on the fuel of glucose (Bordier et al. 2014). Repeated episodes of hypoglycemia may result in neuronal loss (McNay and Cotero 2010). The role of repeated hypoglycemic episodes in the development of cognitive impairment has been explored in several clinical studies (Punthakee et al. 2012; Aung et al. 2012; Whitmer et al. 2009; de Galan et al. 2009; Feil et al. 2011; Bruce et al. 2009). Severe recurrent hypoglycemia in elderly patients with T2DM and several other comorbidities were related to increased cognitive deficits, but it is not clear whether cognitive decline leads to recurrent hypoglycemic events or vice versa. On the other hand, this relationship was not confirmed for patients with T1DM (Jacobson et al. 2007; Reichard et al. 1996). More longitudinal studies need to be conducted to better understand the impact of repeated hypoglycemic episodes on brain structure and function in diabetes.

*Hypothalamic-pituitary-adrenal (HPA) axis dysregulation* has been posited to influence deleterious neuronal changes in patients with DM and seems to be tied to deleterious stress responses and depression. Individuals with DM who have more frequent occurrences of hyperglycemia/hypoglycemia and higher insulin resistance measures tend to have a diurnal cortisol area under the curve that is flatter across the day and with less of a cortisol rise from 0 to 30 min post-awakening and a higher bedtime cortisol as compared to individuals with normal glycemic control (Joseph et al. 2015). Additionally, high cortisol levels, if chronic, have been found to be correlated with structural and functional changes in brain regions, such as the prefrontal cortex, amygdala, and hippocampus, which have densely distributed glucocorticoid receptors, and are important for both emotional and cognitive functions (Joseph et al. 2015; Stranahan et al. 2008). Several studies have shown DM to be associated with blunted stress responsivity with respect to their neuroendocrine (e.g., blunted glucocorticoid and mineralocorticoid sensitivity) and neurophysiologic responses in comparison to healthy controls (Steptoe et al. 2014; Carvalho et al. 2015).

## Cognition and Behavior

Neuropsychological testing of patients with DM demonstrates *very gradual* impairment in specific areas of cognitive function including attention and executive function, processing speed, perception, memory (Lezak 2004), working memory (Luchsinger et al. 2004; Perlmutter et al. 1987), mental flexibility, planning, and verbal memory (Sato and Morishita 2014; Reaven et al. 1990; Gregg et al. 2000; Cosway et al. 2001). Language abilities and visuospatial functions tend to be maintained (Perlmutter et al. 1987). The cognitive changes seen with T2DM are slightly below (i.e., the 35th to 40th percentile) subjects without diabetes, and this is consistent across age groups and gender (Mooradian 1988; Biessels and Reijmer 2014; Zochodne and Toth 2014). Additionally, research is suggesting that lower cognitive function may be developing during prediabetic stages as patients with impaired glucose tolerance (Lamport et al. 2009) or metabolic syndrome (Crichton et al. 2012) are showing similarly lower cognitive function as compared to healthy subjects. Data from longitudinal studies following patients with T2DM and metabolic syndrome show the trajectory of cognitive decline over time is similar to or modestly greater than the cognitive decline that occurs with normal aging (Yaffe et al. 2012; van den Berg et al. 2010; McEvoy et al. 2012). Similar cognitive effects have been seen in patients with T1DM with more global and worse deficits seen in relation to T1DM onset at an earlier age in childhood (Sato and Morishita 2014; Roriz-Filho et al. 2009) (Table 1). Patients with DM and cognitive decline may also show changes in their mood and behavior. Subjects with DM experience increased symptoms of depression, anxiety, apathy, overeating, daytime sleeping or hypersomnia, and decreased engagement in pleasurable activities. Cognitive decline in the areas of planning, organizing, mental flexibility, and working memory as stated above can cause problems with carrying out regular monitoring of their glucose

**Table 1** Evidence showing decline in cognitive abilities in patients with T1DM and T2DM with bolded domains indicating the strongest research evidence for decline in function (Roriz-Filho et al. 2009)

Cognitive measures	T1DM	T2DM
<b>Overall cognitive function</b>	Decline	–
<b>Executive function</b>	Decline	<b>Decline</b>
<b>Verbal memory</b>	Decline	<b>Decline</b>
<b>Nonverbal memory</b>	Decline	<b>Decline</b>
<b>Attention</b>	<b>Decline</b>	Decline
<b>Processing speed</b>	<b>Decline</b>	<b>Decline</b>
<b>Psychomotor function</b>	<b>Decline</b>	–
<b>Visuospatial function</b>	<b>Decline</b>	–

levels, making adjustments to their medications and diet choices to avoid large fluctuations in their glucose levels, engaging in daily activities and physical activity, feeling less autonomous, socializing less, and feelings of increased isolation and depression (Bordier et al. 2014; Vischer et al. 2009; McGuire et al. 2006; Maraldi et al. 2007; Munshi et al. 2006). Some of the decline in behaviors may be due to problems with walking and physical activity, shopping and preparing meals, and fear of falling (Moreira et al. 2016; Walker et al. 2016; Vinik et al. 2015). Therefore, it is important to measure the cognitive, mood, and behavioral factors mentioned above in order to intervene as needed.

## Peripheral Nervous System and Diabetes

Diabetic neuropathy (DN) is the most common and troublesome complication of diabetes mellitus, leading to great morbidity and mortality and resulting in a huge economic burden for diabetes care (Vinik et al. 1995a; Holzer et al. 1998; Hanewinkel et al. 2016). DN is a set of clinical syndromes that affects distinct regions of the nervous system, singly or combined. It may be silent and go undetected while exercising its ravages in up to 50% of the cases; or it may present with clinical symptoms and signs that, although nonspecific and insidious with slow progression, also mimic those seen in many other diseases. DN is, therefore, diagnosed by exclusion (Pop-Busui et al. 2017). Unfortunately neither endocrinologists nor non-endocrinologists have been trained to recognize the condition, and even when DN is symptomatic, less than one third of physicians recognize the cause or discuss this with their patients (Herman and Kennedy 2005).

The true prevalence is not known, and reports vary from 10% to 90%, depending on the criteria and methods used to define neuropathy and on the severity and duration of hyperglycemia (Young et al. 1993; Dyck et al. 1993; Edwards et al. 2008; Abbott et al. 2011). Based upon several large studies, it is reasonable to say that approximately 50% of patients with diabetes will eventually develop neuropathy at some

point in time in their life. Neurologic complications occur equally in type 1 and type 2 diabetes mellitus and additionally in various forms of acquired diabetes (Dyck et al. 1993). The major morbidities associated with neuropathy are foot ulceration, precursor of limb loss, and pain. DN dramatically increases the risk of lower-extremity amputation as a consequence of infected, non-healing foot ulcers. Rates of amputation among populations with diabetes are 10–20 times those of nondiabetic populations and range from 1.5 to 3.5 events per 1000 persons per year (WHO Press Conference 2017). However, it is encouraging that several recent studies have shown a 40–60% reduction in rates of amputations among adults with diabetes during the past 10–15 years in a number of developed countries (Moxey et al. 2011). Diabetic neuropathy also has a tremendous impact on patients' quality of life (QoL) predominantly by causing pain, weakness, ataxia, and incoordination, predisposing to falls and fractures (Vinik et al. 2005; Veresiu et al. 2015). Pain is the reason for 40% of patient visits in a primary care setting, and about 20% of the presenting patients have had pain for greater than 6 months (Mantyselka et al. 2001). Chronic pain may be nociceptive, which occurs as a result of disease or damage to tissue with no abnormality in the nervous system, or neuropathic, which is defined as “pain arising as a direct consequence of a lesion affecting directly the somatosensory system” (Treede et al. 2008). Persistent neuropathic pain interferes significantly with quality of life (QoL), affecting sleep and emotional well-being, and is associated with depression, anxiety, and noncompliance with treatment (Jensen et al. 2007). Neuropathic pain is a difficult-to-manage clinical problem. Two population-based studies showed that neuropathic pain is associated with a greater psychological burden than nociceptive pain (Bouhassira et al. 2008) and is considered to be more severe than other pain types. Early recognition of psychological problems is critical to the management of pain, and physicians need to go beyond the management of pain per se if they are to achieve success. Providing significant pain relief markedly improves quality-of-life measures, including sleep and vitality (Vinik et al. 2005, 2008a).

---

## Pathogenesis of Diabetic Neuropathies

The development of DN is complex and not fully understood. Scientific evidence supports the notion that pathogenesis is multifactorial, with several metabolic pathways being involved (Biessels et al. 2014; O'Brien et al. 2014; Vincent et al. 2011; Zenker et al. 2013). Hyperglycemia and glucose control seems to play a key role in T1DM but affects the development and progression of DN modestly in T2DM. Other pathways involved include inflammatory and oxidative stress, altered lipid metabolism, microvascular insufficiency, defective neurotrophism with impaired nerve regeneration, and autoimmune-mediated nerve destruction (Fig. 3) (Vinik et al. 2006). Detailed discussion of the different theories is beyond the scope of this chapter. However, DN is a heterogeneous group of conditions with widely varying pathologies, suggesting differences in pathogenic mechanisms for the different clinical syndromes.



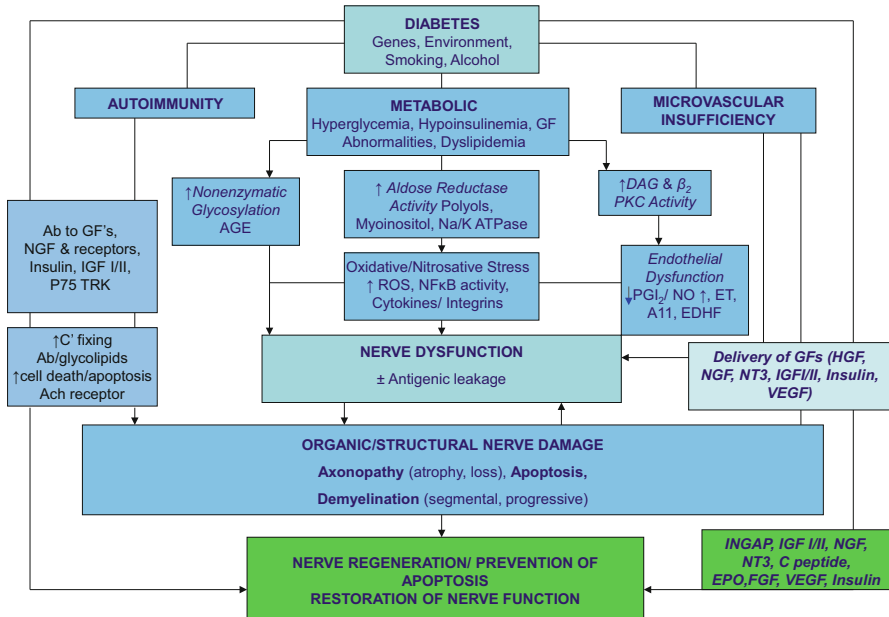
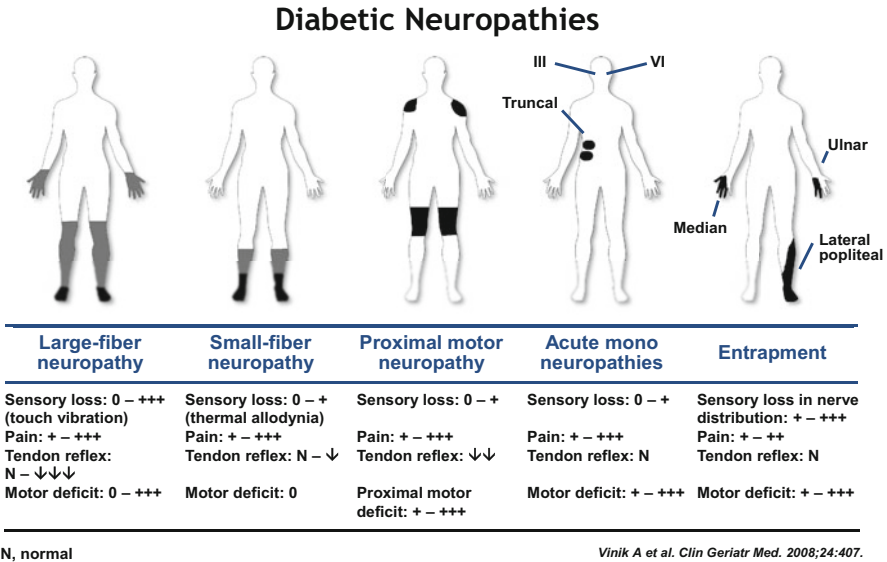

**Fig. 3** Pathogenesis of diabetic neuropathies (Vinik et al. 2006). *Ab* antibody, *AGE* advanced glycation end products; *C'* complement, *DAG* diacylglycerol, *ET* endothelin, *EDHF* endothelium-derived hyperpolarizing factor, *GF* growth factor, *HGF* hepatocyte growth factor, *IGF*, insulin-like growth factor, *NFκB* nuclear factor κB, *NGF* nerve growth factor, *NO* nitric oxide, *NT3* neurotrophin 3, *PKC* protein kinase C, *PGI2* prostaglandin I2, *ROS* reactive oxygen species, *TRK* tyrosine kinase

Recognition of the clinical homologue of these pathologic processes is the first step in achieving the appropriate form of intervention.

### Classification of Diabetic Neuropathies

DN results in a variety of syndromes for which there is no universally accepted classification. They are generally subdivided into focal/multifocal and diffuse neuropathies (Fig. 4). Table 2 describes the classification proposed by the most recent American Diabetes Association (ADA) position statement (Pop-Busui et al. 2017). Distal symmetric polyneuropathy (DSPN) and diabetic autonomic neuropathies are the most common and well-studied neuropathies (Albers and Pop-Busui 2014; Callaghan et al. 2014; Dyck et al. 2011; Malik et al. 2011). It is important to note that different forms of DN often coexist in the same patient (e.g., DSPN and carpal tunnel syndrome). Increasing evidence shows that DN can also be present in subjects with prediabetes and the metabolic syndrome (Smith and Singleton 2012; Singleton et al. 2001; Asghar et al. 2014; Bongaerts et al. 2013; Ziegler et al. 2008a).



**Fig. 4** Classification of diabetic neuropathies (Vinik et al. 2008b)

## Clinical Presentation

The spectrum of clinical neuropathic syndromes described in patients with diabetes mellitus includes dysfunction of almost every segment of the somatic peripheral and autonomic nervous system. Each syndrome can be distinguished by its pathophysiologic, therapeutic, and prognostic features.

## Focal and Multifocal Neuropathies

Focal neuropathies comprise focal limb neuropathies and cranial neuropathies.

Focal limb neuropathies are usually due to entrapment, and mononeuropathies must be distinguished from these entrapment syndromes (Table 3) (Vinik and Mehrabyan 2004; Vinik et al. 2004; Smith 2014). Mononeuropathies often occur in the older population; they have an acute onset, are associated with pain, and have a self-limiting course resolving in several weeks to months (Vinik et al. 2004; Smith 2014). Mononeuropathies can involve the median (5.8% of all diabetic neuropathies), ulnar (2.1%), radial (0.6%), and common peroneal nerves (Wilbourn 1999). Cranial neuropathies in diabetic patients are extremely rare (0.05%) and occur in older individuals with a long duration of diabetes (Watanabe et al. 1990). Entrapment syndromes start slowly and will progress and persist without intervention. Carpal tunnel syndrome occurs three times as frequently in diabetics compared with

**Table 2** Classification of diabetic neuropathies (Pop-Busui et al. 2017)

<b>Diabetic neuropathies</b>
<b>A. Diffuse neuropathy</b>
Distal symmetric polyneuropathy (DSPN)
<ul style="list-style-type: none"> <li>• Primarily small-fiber neuropathy</li> <li>• Primarily large-fiber neuropathy</li> <li>• Mixed small- and large-fiber neuropathy (most common)</li> </ul>
Autonomic neuropathy
Cardiovascular
<ul style="list-style-type: none"> <li>• Reduced HRV</li> <li>• Resting tachycardia</li> <li>• Orthostatic hypotension</li> <li>• Sudden death (malignant arrhythmia)</li> </ul>
Gastrointestinal
<ul style="list-style-type: none"> <li>• Diabetic gastroparesis (gastropathy)</li> <li>• Diabetic enteropathy (diarrhea)</li> <li>• Colonic hypomotility (constipation)</li> </ul>
Urogenital
<ul style="list-style-type: none"> <li>• Diabetic cystopathy (neurogenic bladder)</li> <li>• Erectile dysfunction</li> <li>• Female sexual dysfunction</li> </ul>
Sudomotor dysfunction
<ul style="list-style-type: none"> <li>• Distal hypohydrosis/anhidrosis</li> <li>• Gustatory sweating</li> </ul>
Hypoglycemia unawareness
Abnormal pupillary function
<b>B. Mononeuropathy (mononeuritis multiplex) (atypical forms)</b>
Isolated cranial or peripheral nerve (e.g., CN III, ulnar, median, femoral, peroneal)
Mononeuritis multiplex (if confluent may resemble polyneuropathy)
<b>C. Radiculopathy or polyradiculopathy (atypical forms)</b>
Radiculoplexus neuropathy (a.k.a. lumbosacral polyradiculopathy, proximal motor amyotrophy)
Thoracic radiculopathy
<b>Nondiabetic neuropathies common in diabetes</b>
Pressure palsies
Chronic inflammatory demyelinating polyneuropathy (CIDP)
Radiculoplexus neuropathy
Acute painful small-fiber neuropathies (treatment-induced)

healthy populations (Perkins et al. 2002) and is found in up to one third of patients with diabetes. Its increased prevalence in diabetes may be related to repeated undetected trauma, metabolic changes, or accumulation of fluid or edema within the confined space of the carpal tunnel (Vinik et al. 2004). The diagnosis is confirmed by electrophysiological studies. Treatment consists of rest, aided by placement of a wrist splint in a neutral position to avoid repetitive trauma. Anti-inflammatory medications and steroid injections are sometimes useful. Surgery should be considered if weakness appears and medical treatment fails (Boulton et al. 2004; Vinik and Mehrabyan 2004).

**Table 3** Distinguishing characteristics of mononeuropathies, entrapment syndromes, and distal symmetric polyneuropathy. (Modified from Vinik et al. 2006)

Feature	Mononeuropathy	Entrapment syndrome	Distal symmetric polyneuropathy
<b>Onset</b>	Sudden	Gradual	Gradual
<b>Pattern</b>	Single nerve but may be multiple	Single nerve exposed to trauma	Distal symmetrical polyneuropathy
<b>Nerves involved</b>	CN III, VI, and VII, ulnar, median, peroneal	Median, ulnar, peroneal, medial, and lateral plantar	Mixed, motor, sensory, large-fiber, small-fiber, or mixed neuropathy Autonomic
<b>Natural history</b>	Resolves spontaneously	Progressive	Progressive
<b>Treatment</b>	Symptomatic	Rest, splints, local steroids, NSAIDs, diuretics, surgery	Tight glycemic control, anticonvulsants, SNRIs, tricyclic antidepressants, $\alpha$ -lipoic acid
<b>Distribution of sensory loss</b>	Area supplied by the nerve	Area supplied beyond the site of entrapment	Distal and symmetrical “Glove and stocking” distribution

CN cranial nerves, NSAIDs nonsteroidal anti-inflammatory drugs, SNRIs serotonin-norepinephrine reuptake inhibitors

## Radiculopathies or Polyradiculopathies

**Diabetic lumbar polyradiculopathy (diabetic amyotrophy):** It can be clinically identified based on the occurrence of these common features: (1) primarily affects the elderly (50–60 years old) with type 2 diabetes; (2) onset is abrupt; (3) presents with severe unilateral thigh and hip pain, followed by significant proximal muscle weakness; (4) starts unilaterally but can occur in the contralateral leg, within days to years of the initial attack; (5) often coexists with distal symmetric polyneuropathy; and (6) is characterized by muscle fasciculation, either spontaneous or provoked by percussion. In the classic form of diabetic amyotrophy, axonal loss is the predominant process (Said et al. 1994). Electrophysiologic evaluation reveals lumbosacral plexopathy and is essential to rule out other etiologies, including demyelinating disorders (Sander and Chokroverty 1996; Laughlin and Dyck 2013). It usually resolves spontaneously over time with medical supports and physical therapy (Dyck and Windebank 2002). According to a recent Cochrane Systematic Review, there is no evidence to support the use of immunotherapy for the treatment of this condition (Chan et al. 2012).

**Demyelinating neuropathies:** If demyelination predominates in electrophysiological studies and the motor deficit is symmetric and affects proximal and distal muscle groups, the diagnoses of chronic inflammatory demyelinating polyneuropathy (CIDP), monoclonal gammopathy of unknown significance (MGUS), and vasculitis should be considered (Krendel et al. 1995; Britland et al. 1992). The diagnosis of these demyelinating conditions is often overlooked, although recognition is very important because, unlike polyradiculopathies, they are potentially

treatable. These can occur 11 times more frequently in diabetic than nondiabetic patients (Sharma et al. 2002; Krendel et al. 1997). Treatment options include intravenous immunoglobulin for CIDP (Ayyar and Sharma 2004), plasma exchange for MGUS, steroids and azathioprine for vasculitis, and withdrawal of drugs or other agents that may have caused vasculitis. It is important to divide proximal syndromes into these two subcategories, because the CIDP variant responds dramatically to intervention (Krendel et al. 1995; Barada et al. 1999), whereas amyotrophy runs its own course over months to years.

**Diabetic thoracic polyradiculopathy:** It affects middle-aged to elderly patients and has a predilection for male sex. Pain is the most important symptom, and it occurs in a girdle-like distribution over the lower thoracic or abdominal wall. It can be uni- or bilaterally distributed. Motor weakness is rare. Resolution generally occurs within 4–6 months (Kikita et al. 1982).

### Acute Painful Treatment-Induced Neuropathy

It is a rare small-fiber neuropathy that occurs in patients with chronic hyperglycemia who experience an abrupt improvement in glycemic control (Dabby et al. 2009). Clinical manifestations include severe, distal pain, and recovery soon follows restoration of euglycemia. Recent evidence from a retrospective study of patients referred to a tertiary clinic for diabetic neuropathy evaluation suggests that treatment-induced neuropathy was more frequent than previously thought (Gibbons and Freeman 2015). 104 of 954 patients (11%) developed treatment-induced neuropathy; the risk was greater in subjects with T1DM, a history of eating disorders, treatment with insulin or oral hypoglycemic agents, and greater drops in hemoglobin A1c.

### Distal Symmetric Polyneuropathy (DSPN)

DSPN is the most common form of the diabetic neuropathies (Boulton et al. 2004, 2005; Sinnreich et al. 2005; Dyck et al. 2011; Pop-Busui et al. 2017). It is seen in both type 1 (20% after 20 years of diagnosis) and type 2 DM (10–15% at onset, increasing to 50% after 10 years of disease) (Maser et al. 1989; Tesfaye et al. 1996a; Albers et al. 2010; Young et al. 1993; UK Prospective Diabetes Study (UKPDS) Group 1998). Increasing evidence shows that DSPN is also present in 10–30% of subjects with prediabetes and the metabolic syndrome (Ziegler et al. 2008a, 2014a; Singleton et al. 2001; Callaghan et al. 2016; Asghar et al. 2014; Bongaerts et al. 2013). Sensory symptoms are more prominent than motor symptoms and usually involve the lower limbs. These include pain, paresthesias, hyperesthesia, deep aching, burning, and sharp stabbing sensations. In addition, patients may experience negative symptoms such as numbness in the feet and legs, leading in time to painless foot ulcers and subsequent amputations if the neuropathy is not promptly recognized and treated. Unsteadiness is also frequently seen due to abnormal proprioception and muscle sensory function (Cavanagh et al. 1993; Katoulis et al. 1997). Alternatively,

up to 50% of the patients may be completely asymptomatic, and signs may be only discovered by a detailed neurological examination.

On physical examination, a symmetrical stocking-like distribution of sensory abnormalities in both lower limbs is usually seen. In more severe cases, hands may be involved. All sensory modalities can be affected, particularly vibration, light touch, and joint position perceptions (large  $A\alpha/\beta$  fiber damage) and pain, with abnormal heat and cold temperature perception (small thinly myelinated  $A\delta$ - and unmyelinated C-fiber damage). Deep tendon reflexes may be absent or reduced, especially in the lower extremities. DSPN is frequently accompanied by autonomic neuropathy, which will be described in more detail below. It is important to remember that all patients with DSPN are at increased risk of neuropathic complications such as foot ulceration and Charcot's neuroarthropathy (Boulton 2013; Witzke and Vinik 2012).

$A\alpha$  fibers are large myelinated fibers, in charge of motor functions and muscle control.  $A\alpha/\beta$  fibers are large myelinated fibers too, with sensory functions such as perception to light touch, vibration, and joint position.  $A\delta$ -fibers are small myelinated fibers, in charge of pain stimuli and cold perception. C-fibers can be myelinated or unmyelinated and have both sensory (warm perception and pain) and autonomic functions (blood pressure and heart rate regulation, sweating, etc.) (Vinik 2016) (Table 4).

### **DSPN Is Strongly Linked to Falling**

Progressive loss of sensory perception, proprioception, pain, and temperature discrimination eventually leads to altered balance and incoordination predisposing subjects with DSPN to a higher risk of falls and fractures (Richardson and Hurvitz 1995; Volpato et al. 2005; Boucher et al. 1995; Uccioli et al. 1995; Witzke and Vinik 2005; Herriott et al. 2004; Morrison et al. 2010, 2012; Brown et al. 2015; Resnick et al. 2000, 2002; Strotmeyer et al. 2008; Chiles et al. 2014; Pittenger et al. 2005a; Vinik et al. 2008b). The ability to optimally control one's balance is essential for mobility, avoidance of disability, and preservation of independence in older people (Colberg et al. 2005). The complexity of the balance system makes localization of the problem difficult since the abnormality may occur in one or more of the sensory sites (vision, vestibular, somatosensory) and in the motor system. A thorough evaluation of the sensory-motor systems affecting balance is required to arrive at a diagnosis and to create a platform for optimal treatment. Since neuropathy progression follows a distal-to-proximal gradient, the effects of DSPN on strength and balance are most evident at the ankles and feet. The loss of nerve function can have dramatic implications for both standing and walking tasks (Colberg et al. 2005). For example, diabetic persons with sensory deficits in the feet can exhibit increased postural motion and slower gait speed (Resnick et al. 2000, 2002; Strotmeyer et al. 2008; Chiles et al. 2014) with increased stride time variability (Uccioli et al. 1995; Resnick et al. 2002; Corriveau et al. 2000; Fioretti et al. 2010; Lafond et al. 2004; Lalli et al. 2013; Simoneau et al. 1994; Turcot et al. 2009). Their impact is further magnified when the task is made more difficult, as when walking or standing on irregular surfaces (Richardson and Hurvitz 1995; Richardson et al. 2005,

**Table 4** Approach to the diagnosis of neuropathies of large and small nerve fibers. (Modified from Vinik 2016)

Approach	Large myelinated A-type $\alpha$ - and $\beta$ -fibers	Small myelinated and unmyelinated A-type $\delta$ -fibers and C-type fibers
<b>Symptoms</b>	Numbness, deep-seated gnawing or aching pain affecting the lower extremities, weakness, ataxia with poor balance, increased risk of falling	Tingling, burning pain with sensation of stabbing and electric shocks, allodynia, hyperalgesia, hyperesthesia affecting the lower extremities in a symmetrical, distal-to-proximal pattern. Symptoms of autonomic dysfunction including palpitations, lightheadedness, dizziness, syncope, early satiety, fullness, bloating, nausea, vomiting, dyspepsia, abdominal pain, diarrhea, constipation, erectile dysfunction, and abnormal sweating
<b>Physical examination</b>	Impaired reflexes, loss of proprioception and perception of vibration, wasting of small muscles of hands and feet, weakness in feet	Impaired sensation of warm and cold temperatures and of pinprick; normal strength and reflexes; impaired autonomic function, with resting tachycardia and orthostatic hypotension
<b>Clinical implications</b>	Impaired sense of pressure and balance; susceptibility to falls, traumatic fractures, and Charcot's arthropathy	Impaired nociception, susceptibility to foot ulcers, increased risk of amputations, increased risk of cardiovascular disease
<b>Diagnostic tests</b>	Nerve conduction: abnormal test results (e.g., median, sural, and peroneal nerves). Quantitative sensory testing to detect loss of vibration perception	Nerve conduction: normal results despite presence of symptoms Skin biopsy to detect loss of intraepidermal nerve fiber density Corneal confocal microscopy to detect loss of corneal nerve fiber density and length Quantitative sensory tests to detect loss of hot and cold thermal perception Cardiovascular reflex test and heart rate variability Gastric emptying with scintigraphy Sudorimetry (performed with neuropad, QSART or Sudoscan™) to obtain objective measures of sweating
<b>Differential diagnosis</b>	Chronic inflammatory demyelinating polyneuropathy, monoclonal gammopathies, Guillain-Barré syndrome, and myopathies, B <sub>12</sub> or folate deficiency, hypothyroidism, paraneoplastic syndromes, and effects of chemotherapy	Metabolic causes such as uremia, hypothyroidism, B <sub>12</sub> or folate deficiency, acute intermittent porphyria, toxic alcohol, heavy metals, industrial hydrocarbons, inflammation or infection, connective tissue diseases, vasculitis, celiac disease, sarcoidosis, Lyme disease, human immunodeficiency virus, hepatitis B or C virus, hereditary diseases, monoclonal gammopathies, paraneoplastic syndromes, and amyloidosis

2008). In addition, there is slowing of the reaction time, loss of the ability to prevent progression to a fall after its initiation, and feet dorsiflexion weakness (Strotmeyer et al. 2009), which increase the susceptibility to tripping on loose rugs and carpets and minor variations in step height. Although older adults with diabetes are a heterogeneous group, ranging from fit and healthy to frail with many comorbidities and functional disabilities, poorly controlled diabetes with polyuria escalates falls risk simply because of the number of visits to and urgency to use the bathroom (Berlie and Garwood 2010; Volpato et al. 2005; Maurer et al. 2005; Volpato et al. 2010).

However, risk factors for falling are not simply confined to those variables associated with peripheral sensory-motor function. Cognitive decline (described in detail above), particularly related to executive functioning, is a contributing factor to instability. A recent report from the American Geriatrics Society stressed the significance of any decline in cognitive function for falling, with approximately 60% of older persons with cognitive impairment reporting a fall each year (van Dijk et al. 1993). Falls in older people are associated with changes in the prefrontal cortex leading to failures of executive control (Coppin et al. 2006). Gait performance, particularly changes in stride time variability, has been associated with changes in executive function as well (Hausdorff et al. 2005). Changes in cognitive function also extend to a person's perception of threats in the environment. If an individual perceives himself/herself to be unstable and at risk of falling, he or she may contract (stiffen) the leg muscles to remain stable and adjust his/her gait by walking slower and reducing step length (Imms and Edholm 1981; Maki 1997; Menz et al. 2007). This perception of instability is referred to as fear of falling (Boyd and Stevens 2009; Adkin et al. 2000; Carpenter et al. 2001; Delbaere et al. 2009). Those who develop a fear of falling often further self-limit their activities, leading to reduced mobility and physical fitness and increasing risk of falling (Resnick 1998; Vellas et al. 1997). Ironically, while older people recognize the benefits of activity for reducing their falls risk, many with increased fear of falling reduce their activity even without an underlying injury or medical reason for doing so (Boyd and Stevens 2009). Thus, fear of falling is a major confounding factor to consider when assessing falls risk.

In addition to the general physiological changes often seen with increasing age and progressive disease, the high incidence of polypharmacy (i.e., four or more medications per subject) (Peron and Ogbonna 2015; Kirkman et al. 2012) is another major risk factor for falls (Hanlon et al. 2009; Klein et al. 2003; Woolcott et al. 2009). Research has shown that a simple reduction of psychotropic medications and polypharmacy can result in a significantly reduced falls rate (Panel on Prevention of Falls in Older Persons AGS, British Geriatrics Society 2011; Lloyd et al. 2009). In healthy, non-frail individuals with a >5-year life expectancy, health management goals should be similar to those of the young (American Diabetes Association 2013). However, in frail, elderly patients with diabetes, avoidance of hypoglycemia, hypotension, and drug interactions due to polypharmacy is of even greater concern (Ligthelm et al. 2012). Proper management of coexisting medical conditions is important, as it influences their ability to perform self-management. Hyperglycemia increases dehydration and impairs vision and cognition (Mooradian et al. 1988), all



of which contribute to functional decline and should be avoided in the elderly, diabetic patient. However, side effects of diabetes treatment, most notably hypoglycemia, can result in poor outcomes, such as traumatic falls and exacerbation of comorbid conditions. Similarly, reduction of psychotropic medications and polypharmacy has been shown to also result in a reduced falls rate (Schwartz et al. 2008; Berlie and Garwood 2010; Hanlon et al. 2009; Borenstein et al. 2013; Dyer et al. 2004). Depression is another cognitive factor commonly associated with falls and diabetes due to increased activity avoidance and the prescription of psychotropic medications to treat this disorder (Schwartz et al. 2008; Berlie and Garwood 2010; Hanlon et al. 2009; Woolcott et al. 2009).

Furthermore, the delicacy of electrolyte balance in older people and the use of diuretics and other drugs causing hyponatremia (serum sodium <135 mmol/L) are increasingly recognized as a risk factor. Hyponatremia is associated with gait disturbances, decreased mentation, and falls. Among older patients admitted to the emergency department with asymptomatic, chronic hyponatremia, the incidence of falls was 21.3% in the hyponatremic group compared with 5.3% in controls, and the former group demonstrated highly unstable gait and attention impairment that were completely reversed with correction of hyponatremia (Vinik et al. 2013). While mild hyponatremia can result in unsteady gait, cognitive impairment, and falls by inducing subtle neurologic changes (Renneboog et al. 2006), it likely also directly contributes to the development of osteoporosis and increased bone fragility by inducing increased bone resorption to mobilize sodium (Sandhu et al. 2009). Given that the commonest potentially causative factors in cases of hyponatremia are the use of thiazide diuretics (76%), use of dehydration (70%), and use of proton pump inhibitors (70%), clinicians should check for the presence of hyponatremia and treat it to prevent falls and fractures (Sandhu et al. 2009).

### **What Interventions Work Best for Reducing Falls Risk?**

Recent Cochrane reports cited the development and tailoring of interventions specific to the population group at risk as the issue of most significance in reducing falls (Gillespie et al. 2009; Howe et al. 2011). As most falls occur during movement, identifying factors that negatively impact balance and/or walking ability is critical. Some variables directly affect the components involved in dynamic balance control (e.g., muscle strength, coordination, sensory loss, blood pressure, and pain management), while others can affect balance indirectly by altering the postural processes underlying balance control (e.g., polypharmacy, urinary incontinence, dementia, mild cognitive impairment, mild hypoglycemia and hypoglycemia autonomic failure, and depressive symptoms):

- In order to have a positive effect on falls risk, only those measures that can be modified should be targeted in interventions.
- Various approaches in persons with diabetes can likely reduce falls, such as a reduced intensity of glycemic control, less stringent blood pressure lowering, reduction of polypharmacy, and treatment of neuropathic symptoms (including pain management).

- Physiological variables, such as those underlying strength and balance ability, can be effectively targeted with different exercise interventions.
- Introduction of medical nutrition therapy, including possible replacement of vitamin B<sub>12</sub> and vitamin D, may be beneficial.

Of the numerous falls risk factors identified, those of greater significance tend to be impaired balance and mobility related to age-related declines in physiological functioning (Gillespie et al. 2009). A systematic review has shown that among risk factors that contribute to falls, clinically detected abnormalities of gait and balance are the two most consistent predictors of future falls (Ganz et al. 2007). Consequently, most screening tools and interventions have been specifically designed to target balance, walking dysfunction, reaction time, and muscle weakness, since they are modifiable in older adults and most likely to be positively influenced by tailored interventions. For example, exercise can lead to improvements in body composition and arthritic pain, reduced falls risk and depression, increased strength and balance, improved quality of life, and improved survival for older persons (Christmas and Andersen 2000; Heath and Stuart 2002; Karani et al. 2001). A recent systematic review concluded that a targeted multicomponent training protocol, which includes functional strengthening exercises, walking programs, balance training, or Tai Chi, can promote improvements in gait, balance, and functional activity in people with DSPN without risk of serious adverse events. Further research is needed to determine the optimal exercise combination to develop an evidence-based recommendation for falls prevention program. Future studies should also include a longer period of follow-up to determine the effectiveness of the programs on reducing the number of falls (Gu and Dennis 2017). Figure 5 diagrams the link between screening assessments and potential interventions. Ideally, a person at increased risk should be directed to an intervention designed specific to the major risk factor.

Studies of frail elderly people have shown that weight training should be included in addition to aerobic exercises (Fiatarone et al. 1994). Although numerous studies have shown the benefits of various balance/exercise programs in reducing falls risk in healthy older persons (Robinovitch et al. 2000; Howe et al. 2011; Barnett et al. 2003; Peterson et al. 2009; Sherrington et al. 2003), there have been surprisingly few studies of the benefits of this form of intervention for reducing falls risk in the diabetic population. Those studies performed have reported that targeted interventions can improve both balance and walking abilities and reduce falls risk (Morrison et al. 2010, 2012; Allet et al. 2009). Structured balance training can lead to general improvements in posture and/or gait function (Morrison et al. 2010, 2012; Allet et al. 2010), as well as general gains from physical activity like faster reaction times, improvements in sensory perception and lower-limb strength, and better sympathetic/parasympathetic balance (Morrison et al. 2010, 2012; Herriott et al. 2004; Colberg 2006; Colberg et al. 2002). Interestingly, recent studies have reported that exercise can also lead to improvements in neuropathy symptoms, including increased nerve fiber branching (Kluding et al. 2012) and improved sensory responses in the lower limbs (Balducci et al. 2006).

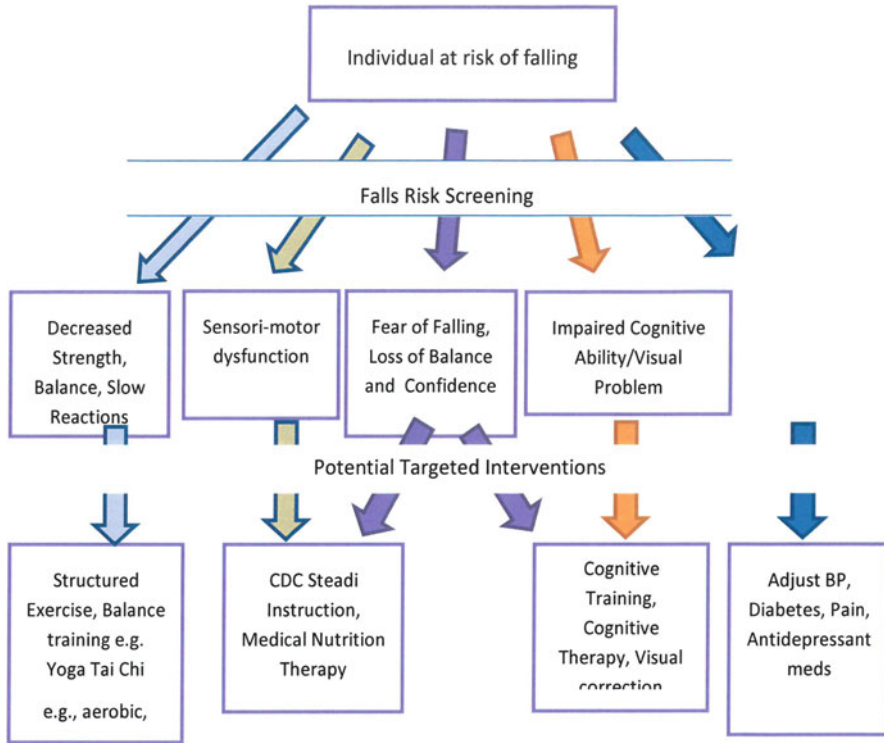

**Fig. 5** Falls risk screening and potential targeted interventions. *BP* blood pressure, *CDC* Center for Disease Control. (Reprinted by permission from AACE. *Endocr Pract.* 2017;23: 1120–1142)

### Screening and Diagnosis of Diabetic Neuropathies

DN is grossly underdiagnosed. This is in part due to the lack of agreement on the definition and diagnostic assessment of DNs. DSPN is the most common type, accounting for 75% of the cases (Dyck et al. 2011; Pop-Busui et al. 2017). In 2010 the Toronto Consensus Panel redefined the minimal criteria for the diagnosis of typical DSPN as summarized below (Tesfaye et al. 2010).

#### Toronto Classification of DSPN (Tesfaye et al. 2010)

1. *Possible DSPN*: The presence of symptoms or signs of DSPN may include the following: symptoms, decreased sensation; positive neuropathic sensory symptoms (e.g., “asleep numbness,” prickling or stabbing, burning or aching pain) predominantly in the toes, feet, or legs; and signs, symmetric decrease of distal sensation or unequivocally decreased or absent ankle reflexes.

2. *Probable DSPN*: The presence of a combination of symptoms and signs of neuropathy including any two or more of the following: neuropathic symptoms, decreased distal sensation, or unequivocally decreased or absent ankle reflexes.
3. *Confirmed DSPN*: The presence of an abnormality of nerve conduction and a symptom or symptoms, or a sign or signs, of neuropathy confirms DSPN. If nerve conduction is normal, a validated measure of small-fiber neuropathy (SFN) (with class 1 evidence) may be used. To assess for the severity of DSPN, several approaches can be recommended, e.g., the graded approach outlined above, various continuous measures of sum scores of neurologic signs, symptoms or nerve test scores, scores of function of activities of daily living, and scores of predetermined tasks or of disability.
4. *Subclinical DSPN*: The presence of no signs or symptoms of neuropathy is confirmed with abnormal nerve conduction or a validated measure of SFN (with class 1 evidence). Definitions 1, 2, and 3 can be used for clinical practice and definitions 3 and 4 can be used for research studies.
5. *Small-fiber neuropathy (SFN)*: SFN should be graded as follows: (1) possible, the presence of length-dependent symptoms and/or clinical signs of small-fiber damage; (2) probable, the presence of length-dependent symptoms, clinical signs of small-fiber damage, and normal sural nerve conduction; and (3) definite, the presence of length-dependent symptoms, clinical signs of small-fiber damage, normal sural nerve conduction, and altered intraepidermal nerve fiber density (IENFD) at the ankle and/or abnormal thermal thresholds at the foot (Tefsaye et al. 2010) (see Fig. 5).

## Clinical Assessment of DSPN

Early diagnosis of DSPN is critical to prevent irreversible damage. Assessment should include a complete and detailed medical and neurological history (Fig. 6). Symptoms of DSPN vary, according to the type of nerve fibers involved (Table 4). The earliest symptom is neuropathic pain (small-fiber dysfunction) that can be present in up to 25% of the cases (Davies et al. 2006; Ziegler et al. 2009a). It is characterized by tingling, burning, or lancinating pain with sensation of stabbing and electric shocks affecting the lower extremities in a symmetrical, distal-to-proximal pattern, together with hyperalgesia (exaggerated response to painful stimuli), hyperesthesia, and allodynia (pain evoked by non-painful stimuli) (Malik et al. 2011; Baron et al. 2009; Freeman et al. 2014). Pain is usually worse at night and can lead to significant reduction of quality of life and disability (Van et al. 2009). Numbness and loss of protective sensation in a “stocking and glove” distribution occur with involvement of large fibers. Complete physical examination with vascular and neurologic tests should be performed. The neurological examination should always include an accurate foot inspection for deformities, ulcers, fungal infection, muscle wasting, hair distribution or loss, and the presence or absence of pulses. Sensory modalities should be assessed using simple handheld devices (touch by cotton wool or soft brush; vibration by 128 Hz tuning fork; pressure by the Semmes-Weinstein 1

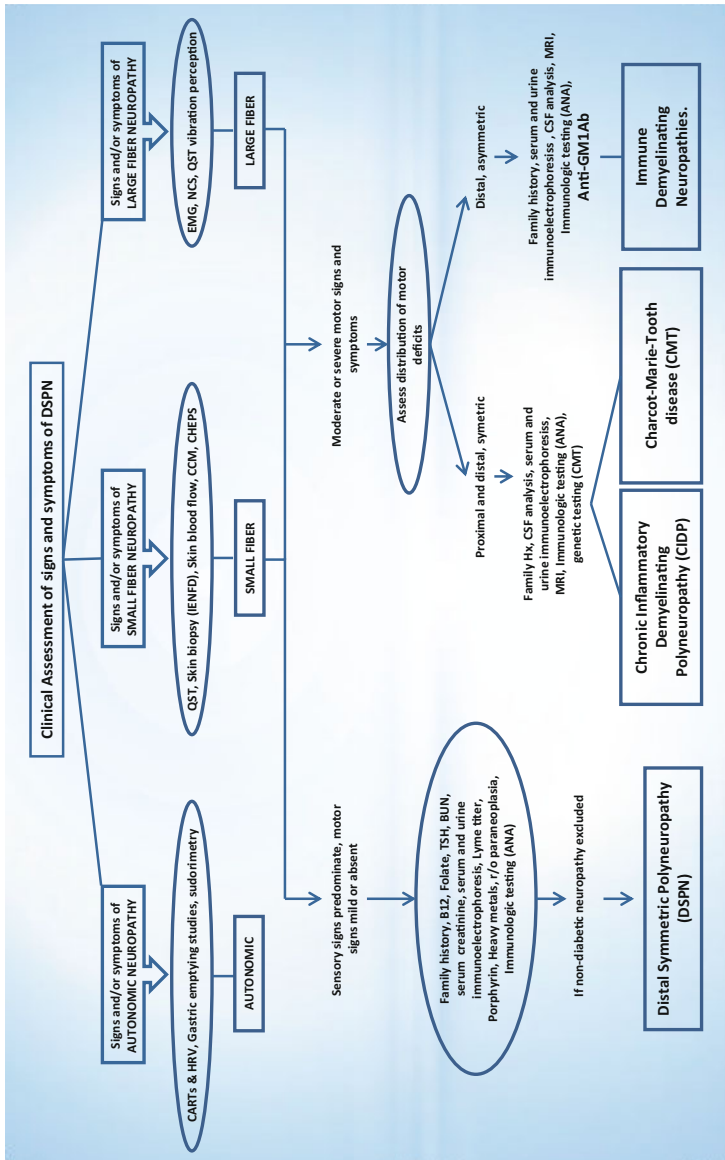

**Fig. 6** Diagnostic algorithm for the assessment of DSPN. *B12* vitamin B<sub>12</sub>, *BUN* blood urea nitrogen, *CHEPs* contact heat evoked potentials, *CIDP* chronic inflammatory demyelinating polyneuropathy, *EMG* electromyogram, *Hx* history, *MGUS* monoclonal gammopathy of unknown significance, *NCS* nerve conduction studies, *NIS* neurologic impairment score (sensory and motor evaluation), *NSS* neurologic symptom score, *QAFt* quantitative autonomic function tests, *QSTs* quantitative sensory tests, *Sudo* sudomotor function testing. (Modified from Vinik et al. 2006)

**Table 5** Physical examination – bedside sensory tests (Haanpaa et al. 2009)

Sensory modality	Nerve fiber	Instrument	Associated sensory receptors
Vibration	A $\beta$ (large)	128 Hz Tuning fork	Ruffini corpuscle mechanoreceptors
Pain (pinprick)	C (small)	Neurotips Wartenberg wheel	Nociceptors for pain and warmth
Pressure	A $\beta$ , A $\alpha$ (large)	1 and 10 g monofilament	Pacinian corpuscle
Light touch	A $\beta$ , A $\alpha$ (large)	Wisp of cotton	Meissner's corpuscle
Cold	A $\delta$ (small)	Cold tuning fork	Cold thermoreceptors

and 10 g monofilament; pinprick by Wartenberg wheel, Neurotips, or a pin; temperature by cold and warm objects) (Table 5) (Haanpaa et al. 2009). For the monofilament test, a simple substitute is to use 25 lb strain fishing line cut into 4 and 8 cm lengths, which translate to 10 and 1 g monofilaments, respectively (Bourcier et al. 2006). Vibration detection threshold and 10 g monofilament have been validated for the screening of DSPN (Perkins et al. 2001). Combinations of more than one test have shown to increase sensitivity and specificity of detecting DSPN in both T1DM and T2DM (Vinik et al. 1995b; Pop-Busui et al. 2013a, 2017; Bril and Perkins 2002; Herman et al. 2012; Martin et al. 2006; Singleton et al. 2008; Herder et al. 2013). Longitudinal studies have shown that these simple tests are good predictors of foot ulcer risk (Abbott et al. 2002). However, these physical examination tests are limited by intrinsic factors such as insufficient reproducibility and that they primarily detect large-fiber dysfunction (Dyck et al. 2010). Finally, muscle strength and the Achilles reflexes should be tested (Tables 4 and 5). Mild muscle wasting may be seen, but severe weakness is rare and suggests a nondiabetic cause. In more severe cases, the hands may be involved. Patients with asymmetric symptoms or signs, greater impairment of motor rather than sensory function, entrapment, or rapid progression should be carefully assessed for other conditions. A history of drug or chemical exposures and a family history of inherited neuropathies should be obtained. Objective testing for neuropathy (including quantitative sensory testing, measurement of nerve conduction velocities, and tests of autonomic function) may be required to make a definitive diagnosis of neuropathy, although it is not essential for clinical care. Laboratory studies should include tests for thyroid function, a complete blood count, serum levels of folate and vitamin B<sub>12</sub> (metformin has been associated with vitamin B<sub>12</sub> deficiency), and serum immunoelectrophoresis (Fig. 6 and Table 4) (Vinik 2016).

Clinical assessment should be standardized and conducted using validated, reproducible scores for both the severity of symptoms and the degree of neuropathic deficits. Several scores and questionnaires are available including the Michigan Neuropathy Screening Instrument (MNSI) (Feldman et al. 1994), the Neuropathy Symptom Score for neuropathic symptoms (Young 1993), and the Neuropathy Disability Score (NDS) or the Neuropathy Impairment Score (NIS) and NIS-LL

(lower extremities) for neuropathic deficits (Young et al. 1993). The NIS-LL is a validated tool for quantifying the severity of peripheral neuropathy and includes the components of sensation, reflexes, and muscle weakness (Bril 1999). It has shown to be sensitive to small-fiber sensory change in interventional studies (Apfel et al. 1998). The Utah Early Neuropathy Scale (UENS) is a simple, rapid, and reproducible test targeted to detect early sensory peripheral neuropathy. It includes motor examination, pin sensation, allodynia, hyperesthesia, large-fiber sensation, and deep tendon reflexes. It has a good inter-rater reliability (interclass correlation of 94%) and correlates significantly with other neuropathy scores and confirmatory tests. UENS has shown superior sensitivity (92%) to detect early neuropathy, when compared with other scores (MDNS (67%) or NIS-LL (81%)), without sacrificing specificity. This makes it a sensitive and reproducible clinical measure of sensory small-fiber nerve injury (Singleton et al. 2008). The Toronto Clinical Neuropathy Score (TCNS) is a validated grading assessment that uses elements of history and physical examination to estimate severity of neuropathy (Bril and Perkins 2002). Symptoms of neuropathy are personal experiences and vary markedly from one patient to another. For this reason, a number of symptom screening questionnaires with similar scoring systems have been developed. The Neurologic Symptom Score (NSS) has 38 items that capture symptoms of muscle weakness, sensory disturbances, and autonomic dysfunction. These questionnaires are useful for patient follow-up and to assess response to treatment.

## Conditions Mimicking Diabetic Neuropathy

There are a number of conditions that can be mistaken for painful diabetic neuropathy: intermittent claudication, in which the pain is exacerbated by walking; Morton's neuroma, in which the pain and tenderness are localized to the intertarsal space and are elicited by applying pressure with the thumb in the appropriate intertarsal space; osteoarthritis, in which the pain is confined to the joints, made worse with joint movement or exercise, and associated with morning stiffness that improves with ambulation; radiculopathy, in which the pain originates in the shoulder, arm, thorax, or back and radiates into the legs and feet; Charcot's neuropathy, in which the pain is localized to the site of the collapse of the bones of the foot and the foot is hot rather than cold as occurs in neuropathy; plantar fasciitis, in which there is shooting or burning in the heel with each step and there is exquisite tenderness in the sole of the foot; and tarsal tunnel syndrome, in which the pain and numbness radiate from beneath the medial malleolus to the sole and are localized to the inner side of the foot. These contrast with the pain of DPN which is bilateral and symmetrical, covering the whole foot and particularly the dorsum, and is worse at night interfering with sleep. The most important differential diagnoses from the general medicine perspective include neuropathies caused by alcohol abuse, uremia, hypothyroidism, vitamin B<sub>12</sub> deficiency, peripheral arterial disease, cancer, inflammatory and infectious diseases, and neurotoxic drugs (Young et al. 1988).

The most recent American Diabetes Association (ADA) position statement and American Association of Clinical Endocrinologists (AACE)/American College of Endocrinology (ACE) guidelines on DN agree and recommend the following for the screening and diagnosis of DSPN (Pop-Busui et al. 2017; Handelsman et al. 2015):

- All T2DM patients and T1DM patients with  $\geq 5$  years of diagnosis should be assessed for the presence of DSPN and at least yearly thereafter.
- Patients with prediabetes and/or metabolic syndrome with symptoms of neuropathy should also be screened for the presence of DSPN.
- Assessment should include a detailed history and objective measures of small-fiber (temperature or pinprick sensation) and large-fiber function (vibration sensation using a 128 Hz tuning fork, 1 and 10 g monofilament pressure perception, ankle reflexes). All patients should have an annual 10 g monofilament testing to assess for feet at risk for ulceration and amputation.
- Electrophysiological testing or referral to a neurologist is rarely needed for screening, except in situations where the clinical features are atypical, the diagnosis is unclear, or a different etiology is suspected. Atypical features include motor greater than sensory neuropathy, rapid onset, or asymmetrical presentation.

## Objective Devices for the Diagnosis of Neuropathy

Objective testing for neuropathy (including quantitative sensory testing, nerve conduction studies, and tests of autonomic function), although not essential for clinical care, are sometimes required to make a definitive diagnosis of neuropathy and are frequently used in clinical research as endpoints.

**Quantitative sensory testing (QST):** Quantification of cooling and warm perception thresholds has proven to be useful for the evaluation of small-fiber function, and a number of instruments including the CASE IV thermoesthesiometer and Medoc TSA-II NeuroSensory Analyzer have been used to quantify these parameters. It enables more accurate assessment of sensory deficits by applying controlled stimuli and standardized procedures. In 498 type 2 diabetic patients and 434 control subjects, an elevated warm threshold was the most frequent abnormality (60.2%) compared with an abnormal cold threshold (39.6%) and abnormal sural nerve conduction velocity (12.9%), and it was related to both symptoms and glycemic control (Chao et al. 2007). Recent literature has also shown that cooling detection thresholds have acceptable reproducibility for the detection of DSPN in both T1- and T2DM patients (83% sensitivity and 82% specificity for T1DM and 64% sensitivity and 83% specificity for T2DM). These findings support not only the use of QST in clinical research but also encourage further research into development of feasible devices for rapid screening of early neuropathy into the community, thus targeting the disease process early, at its most treatable stage (Backonja et al. 2013; Geber et al. 2011; Moloney et al. 2012; Zinman et al. 2004; Farooqi et al. 2016; Lysy et al. 2014). However, these findings must be confirmed in larger cohorts or pooled



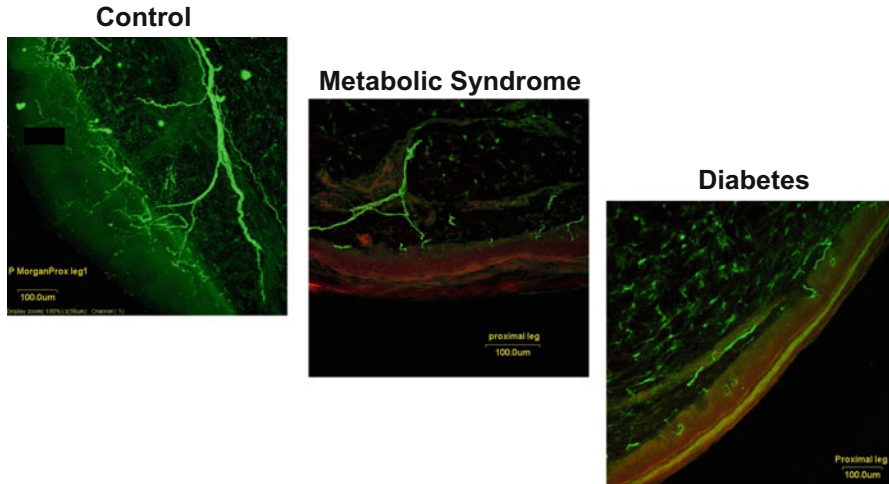

**Fig. 7** Intraepidermal nerve fiber (IENF) density in small-fiber neuropathy. Figure shows loss of cutaneous nerve fibers that stain positive for the neuronal antigen protein gene product 9.5 (PGP 9.5) in metabolic syndrome and diabetes compared to healthy controls. (Vinik et al. 2006. Reprinted by permission from Springer Nature)

analysis of multiple studies. The Toronto Consensus Panel included QSTs as a validated measure for the diagnosis of definite SFN (Malik et al. 2011).

**Skin biopsy and quantification of intraepidermal nerve fiber density (IENFD):** The importance of the skin biopsy as a diagnostic tool for DPN is increasingly being recognized (Pittenger et al. 2004; Polydefkis et al. 2001). This minimally invasive technique quantitates small epidermal nerve fibers through antibody staining of the pan-axonal marker protein gene product 9.5 (PGP 9.5). It enables a direct study of small fibers, which cannot be evaluated by NCV studies. It allows morphometric quantification of intraepidermal nerve fibers (IENF) expressed as the number of IENF per length of section (IENF/mm) or density (Lauria and Lombardi 2007) (Fig. 7). Intra- and inter-observer variability for the assessment of IENF density demonstrates good agreement (England et al. 2009; Smith et al. 2005), declines with age, and does not appear to be influenced by weight or by height (Bakkers et al. 2009). An international consortium of investigators has recently compiled a normative database for intraepidermal nerve fiber density (IENFD) in 550 participants (Lauria et al. 2010a, b). IENFD has led to the recognition of SFN as part of IGT and the metabolic syndrome.

**In vivo corneal confocal microscopy (IVCCM):** The gold standard for measuring small-fiber neuropathy is the assessment IENFD through skin biopsies, as described above. However, its invasive nature makes it less practical for the screening of DSPN in the community. In vivo corneal confocal microscopy (IVCCM) has emerged as a tool for detecting early morphological alterations in small nerve fibers of the subbasal nerve fiber plexus of the cornea, adjacent to the corneal Bowman's layer (Fig. 8). Corneal innervation is mainly sensory and derived from the ciliary



**Fig. 8** In vivo corneal confocal microscopy (IVCCM) for the assessment of DSPN

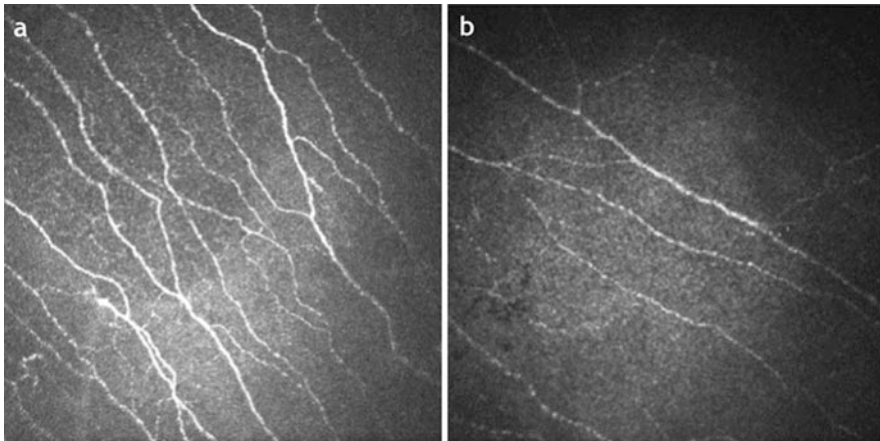
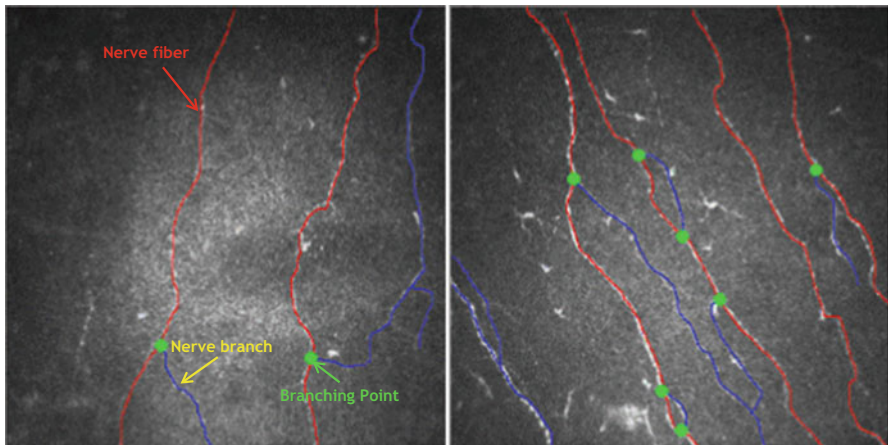

**Fig. 9** IVCCM images in health and disease. (a) Healthy control subject, (b) T2DM subject with DSPN

nerves of the ophthalmic branch of the trigeminal ganglion (Cruzat et al. 2017). Corneal nerve fibers are decreased in subjects with DM when compared to healthy controls (Fig. 9). Numerous studies in the last decade have investigated the use of IVCCM for the diagnosis of DSPN. IVCCM features correlate well with IENFD and other measures of SFN, and cross-sectional and longitudinal studies of their

diagnostic performance for DSPN in both T1DM and T2DM have been validated (Tavakoli et al. 2010; Hertz et al. 2011; Ahmed et al. 2012; Efron et al. 2010; Wu et al. 2012; Petropoulos et al. 2013a; Stem et al. 2014; Azmi et al. 2015; Ziegler et al. 2014b; Chen et al. 2015; Edwards et al. 2012; Sivaskandarajah et al. 2013; Jiang 2016). Furthermore, there is also evidence of its utility in prediabetes and newly diagnosed T2DM, and it has shown good correlation with severity and progression of DSPN (Tavakoli and Malik 2011; Petropoulos et al. 2013b). However, the time and expertise required for image analysis limit the ability of this tool to be used in large clinical settings. Investigators from the University of Manchester have recently developed a tool capable of automated analysis of individual images, which eliminates the need for trained personnel and reduces the time it takes to analyze the images (Fig. 10). The reproducibility of the automated analysis has been confirmed in several studies (Dabbah et al. 2011; Ostrovski et al. 2015; Dehghani et al. 2014).

**Sudomotor function:** Sudoscan<sup>TM</sup> (Impeto Medical, Paris, France) measures the capacity of the sweat glands to release chloride ions in response to electrochemical activation. A low-voltage (<4 V) galvanic current stimulates the underlying sweat glands, which generates a measurable flow of ions through the sweat ducts. Electrochemical skin conductance (ESC) of hands and feet are measured using two well-known principles: reverse iontophoresis and electrochemistry. ESC, expressed in micro-siemens ( $\mu\text{S}$ ), is the ratio between the current generated and the constant direct voltage stimulus applied between the electrodes. Measurement of ESC is dependent on the glands' capability to transfer chloride ions and reflects small C-fiber function (Mayaudon et al. 2010). Sudoscan has been compared with other reference tests



**Fig. 10** IVCCM analysis of corneal nerve fibers using CCMetrics/ACCMetrics\* (Dabbah et al. 2011). \*Software developed by the University of Manchester. Manual involves manually tracing and placing cursor marks over fibers and branches which allows for quantification of corneal nerve fiber length (CNFL, measured in units of  $\text{mm}/\text{mm}^2$ ), corneal nerve fiber density (CNFD, measured in units of  $\text{fibers}/\text{mm}^2$ ), and corneal nerve branch density (CNBD, measured in units of  $\text{branches}/\text{mm}^2$ ). In the automated version, the counting is done entirely by the software

(including HRV indices, intraepidermal nerve fiber density, and quantitative sudomotor axon reflex testing (QSART)), and it has shown to be useful in the detection of small nerve fiber neuropathy in patients with and without T2DM with a sensitivity of 77–87% and a specificity of 67–92% (AUC 0.77–0.88) (Casellini et al. 2013; Freedman et al. 2014, 2015; Selvarajah et al. 2015). Recently, normative reference values have been established on a total of 1350 healthy participants, ages 21–80. The study showed no effect of gender, weight, or BMI on ESC of hands and feet. A weak but significant influence of age was detected for hands ( $r = -0.17$ ,  $p < 0.0001$ ) and feet ESC ( $r = -0.19$ ,  $p < 0.0001$ ). Significantly lower ESCs were observed for African American, Indian, and Chinese populations, and a nomogram has been created to correct the ESC values on these populations (Parekh et al. 2016). During the test, patients are required to place their hands and feet on the electrodes and to stand still for 2–3 min. The device produces ESC results for individual's right and left hands and feet and then calculates an average score between right and left hands and feet. The reproducibility of these measurements has been validated in previous studies, and inter-device reproducibility has been confirmed through measurements with two different devices (Calvet et al. 2012; Raisanen et al. 2014).

**Electrophysiology and nerve conduction studies (NCS):** The use of electrophysiologic measures (NCV) in both clinical practice and multicenter clinical trials is recommended (American Diabetes Association American Academy of Neurology 1988; Consensus Report of the Peripheral Nerve Society 1995). In a long-term follow-up study of type 2 diabetic patients (Partanen et al. 1995), NCV abnormalities in the lower limbs increased from 8% at baseline to 42% after 10 years of disease. A slow progression of NCV abnormalities was seen in the Diabetes Control and Complications Trial (DCCT). The sural and peroneal nerve conduction velocities diminished by 2.8 and 2.7 m/s, respectively, over a 5-year period (DCCT Research Group 1995a). Furthermore, in the same study, patients who were free of neuropathy at baseline had a 40% incidence of abnormal NCV in the conventionally treated group versus 16% in the intensive therapy-treated group after 5 years. However, the neurophysiologic findings vary widely depending on the population tested and the type and distribution of the neuropathy. Patients with painful, predominantly small-fiber neuropathy have normal studies. There is consistent evidence that small, unmyelinated fibers are affected early in DM, and these alterations are not diagnosed by routine NCV studies. Therefore, other methods, such as QST, autonomic testing, or skin biopsy with quantification of intraepidermal nerve fibers (IENF), are needed to detect these patients (Gibbons 2014; Pittenger et al. 2004, 2005b; Sinnreich et al. 2005). Nevertheless electrophysiological studies play a key role in ruling out other causes of neuropathy and are essential for the identification of focal and multifocal neuropathies (Boulton et al. 2004; Vinik et al. 2004).

**Quality of life:** It is widely recognized that neuropathy per se can affect the quality of life (QoL) of the diabetic patient. A number of instruments have been developed and validated to assess QoL in DN. The Neuro-QoL measures patients' perceptions of the impact of neuropathy and foot ulcers (Vileikyte et al. 2003). The Norfolk Quality of Life-Diabetic Neuropathy (Norfolk QoL-DN) tool is a validated,

35-item, self-administered questionnaire that measures the relationship between symptoms of diabetic neuropathy and QoL. It includes measures of autonomic and somatic nerve dysfunction (Vinik et al. 2005). The tool is available in several validated language versions (Vinik et al. 2008a). It has been shown to be an excellent screening tool for the diagnosis of neuropathy, can discriminate mild from more severe neuropathy, and has been used successfully in trial of an intervention (Boyd et al. 2011).

---

## Cardiac Autonomic Neuropathy

Cardiac autonomic neuropathy (CAN) is a common and important complication of DM. The most common symptoms of CAN include dizziness, palpitations, lightheadedness, and weakness and are the consequence of dysregulation of the cardiovascular system, secondary to dysfunction of the sympathetic and parasympathetic nervous system. However, these symptoms can occur very late in the disease process. Early autonomic dysfunction can be completely asymptomatic and only detected by abnormal heart rate variability (HRV) indices. In more advanced cases, patients develop resting tachycardia (>100 bpm), orthostatic hypotension, exercise intolerance, and syncope (Spallone et al. 2011a; Vinik and Ziegler 2007; Pop-Busui 2010; The Consensus Committee of the American Autonomic Society and the American Academy of Neurology 1996).

CAN prevalence increases substantially with diabetes duration in both T1DM (30% after 20 years) (Spallone et al. 2011a; Martin et al. 2014; Pop-Busui et al. 2009) and T2DM (up to 60% after 15 years) (Spallone et al. 2011a; Low 1996; Low et al. 2004). In addition, CAN is present in patients with prediabetes (Ziegler et al. 2008a, 2015a; Carnethon et al. 2006). Early diagnosis of cardiac autonomic dysfunction is important, as it has been shown to be an independent risk factor for cardiovascular mortality, arrhythmias, major cardiovascular event, and myocardial dysfunction (Maser et al. 2003; Pop-Busui et al. 2010, 2013b; Young et al. 2009; Ziegler et al. 2008b; Lykke et al. 2008). Several studies, including ADVANCE, VADT, and ACCORD (ADVANCE Collaborative Group 2008; Duckworth et al. 2009; Pop-Busui et al. 2010; Pop-Busui 2010; Wackers et al. 2004), have shown that cardiac autonomic dysfunction may predict the risk of cardiovascular events and sudden death seen with intensification of glycemic control in subjects with T2DM. Furthermore, it has been recently shown that cardiac autonomic dysfunction is an independent risk factor for cardiovascular disease (CVD). In a post hoc analysis of two large cohorts of patients with stable chronic CVD (ONTARGET and TRANSCEND), resting baseline and in-trial average heart rate (HR) were independently associated with significant increases in cardiovascular events and all-cause mortality (Lonn et al. 2014). Wulsin and colleagues examined the contribution of two measures of autonomic imbalance, resting heart rate, and heart rate variability (HRV), on the development of CVD, diabetes, and early mortality. Both measures, along with sex, age, and smoking, were significant predictors for the development of CVD, DM, and early mortality within 12 years in

the Framingham Heart Study offspring cohort (Wulsin et al. 2015). Zafrir and colleagues also showed that resting tachycardia ( $>100$  beats/min), chronotropic incompetence, and reduced heart rate recovery after treadmill exercises were independently and additively associated with long-term mortality, myocardial infarction, or stroke in type 2 diabetes without known coronary heart disease (hazard ratios of 1.97, 1.89, and 1.77, respectively) (Zafrir et al. 2016). CAN was also the strongest risk factor for mortality in a large cohort of patients with T1DM in the EURODIAB Prospective Cohort Study (Soedamah-Muthu et al. 2008), and a meta-analysis of several trials reported higher mortality risk with worsening measures of CAN (Maser et al. 2003).

Diagnosis can be done clinically in advanced stages, but HRV testing might be needed in early stages of cardiac autonomic dysfunction. Testing HRV may be done in the office by taking an electrocardiogram recording during 1–2 min of deep breathing with calculation of HRV indices including SDNN and rMSSD (Pop-Busui 2010; Bernardi et al. 2011; Spallone et al. 2011b).

The Toronto Consensus Panel, the European Society of Cardiology, the North American Society of Pacing and Electrophysiology, and the ADA position statement on DN recommend the following regarding CAN measures for clinical trials targeting either a specific intervention or for prognostic implications (Bernardi et al. 2011; Task Force of the European Society of Cardiology and the North American Society of Pacing and Electrophysiology 1996):

- Standardized cardiovascular autonomic reflex tests: simple, sensitive, specific, and reproducible tests that assess changes in the R-R interval on electrocardiogram recordings in response to simple clinical maneuvers (deep breathing, Valsalva, and standing)
- Indices of HRV including SDNN (standard deviation of the beat-to-beat (NN) variability) which is a measure of both sympathetic and parasympathetic actions on HRV and root mean square of successive R-R intervals (rMSSD), a measure primarily of parasympathetic activity
- Resting heart rate and QTc

CAN treatment is generally focused on alleviating symptoms and should be targeted to the specific clinical manifestation. Exercise, volume repletion, low-dose fludrocortisone, and midodrine are among the most frequently used.

Recommendations for the treatment of CAN include the following (Pop-Busui et al. 2017):

1. Early optimization of glucose control to prevent or delay the development of CAN in people with T1DM
2. Multifactorial approach targeting glycemia and other risk factors (dyslipidemia, hypertension) to prevent cardiovascular autonomic neuropathy in people with type 2 diabetes
3. Lifestyle modifications to improve cardiovascular autonomic neuropathy in patients with prediabetes

## Treatment of Diabetic Polyneuropathies

Treatment of DN should be targeted toward a number of different aspects: firstly, treatment of specific underlying pathogenic mechanisms; secondly, treatment of symptoms and improvement in QoL; and thirdly, prevention of progression and treatment of complications of neuropathy (Cameron et al. 2001).

### Treatment of Specific Underlying Pathogenic Mechanisms

#### Glycemic and Metabolic Control

Several long-term prospective studies have assessed the effects of intensive diabetes therapy on the prevention and progression of chronic diabetic complications, including neuropathy. Large randomized trials such as the Diabetes Control and Complications Trial (DCCT) and the UK Prospective Diabetes Study (UKPDS) were not designed to evaluate the effects of intensive diabetes therapy on DSPN but rather to study the influence of such treatment on the development and progression of the chronic diabetic complications (UK Prospective Diabetes Study (UKPDS) Group 1998; The Diabetes Control and Complications Trial Research Group 1993). Thus, only a minority of the patients enrolled in these studies had symptomatic DSPN at entry. However, DCCT in T1DM subjects have shown that improved glucose control reduces the incidence of DSPN (78% relative risk reduction) (DCCT Research Group 1995b). In the DCCT/EDIC cohort, the benefits of former intensive insulin treatment persisted for 13–14 years after DCCT closeout and provided evidence of a durable effect of prior intensive treatment on polyneuropathy and cardiac autonomic neuropathy (CAN) (“hyperglycemic memory”) (Albers et al. 2010; Pop-Busui et al. 2009). Intensive glucose control in the DCCT and its follow-up Epidemiology of Diabetes Interventions and Complications (EDIC) study reduced the risk of incident CAN by 45% and 31%, respectively (Martin et al. 2014). In contrast, in T2DM patients, the results were largely negative. The UKPDS showed a lower rate of impaired VPT (VPT >25 V) after 15 years for intensive therapy (IT) versus conventional therapy (CT) (31% vs. 52%). However, the only additional time point at which VPT reached a significant difference between IT and CT was the 9-year follow-up, whereas the rates after 3, 6, and 12 years did not differ between the groups. Likewise, the rates of absent knee and ankle reflexes as well as the heart rate responses to deep breathing did not differ between the groups (UK Prospective Diabetes Study (UKPDS) Group 1998). In the ADVANCE study including 11,140 patients with type 2 diabetes randomly assigned to either standard glucose control or intensive glucose control, the relative risk reduction (95% CI) for new or worsening neuropathy for intensive versus standard glucose control after a median of 5 years of follow-up was  $-4$  ( $-10$  to  $2$ ), without a significant difference between the groups (ADVANCE Collaborative Group 2008). Likewise, in the VADT study including 1791 military veterans (mean age, 60.4 years) who had a suboptimal response to therapy for type 2 diabetes, after a median follow-up of 5.6 years, no differences between the two groups on intensive or standard glucose control were observed for

DSPN or microvascular complications (Duckworth et al. 2009). In the ACCORD trial (Ismail-Beigi et al. 2010), intensive therapy aimed at HbA1c <6.0% was stopped before study end because of higher mortality in that group, and patients were transitioned to standard therapy after 3.7 years on average. At transition, loss of sensation to light touch was significantly improved on intensive versus standard diabetes therapy. At study end after 5 years, MNSI score >2 and loss of sensation to vibration and light touch were significantly improved on intensive versus standard diabetes therapy. However, because of the premature study termination and the aggressive HbA1c goal, the neuropathy outcome in the ACCORD trial is difficult to interpret. In the Steno 1 and 2 Study (Gaede et al. 2003, 2008), intensified multifactorial risk intervention including intensive diabetes treatment, angiotensin-converting enzyme (ACE) inhibitors, antioxidants, statins, aspirin, and smoking cessation in patients with microalbuminuria showed no effect on DSPN after 7.8 (range 6.9–8.8) years and again at 13.3 years. However, the progression of cardiac autonomic neuropathy (CAN) was reduced by 57%. Thus, there is no evidence that intensive diabetes therapy or a target-driven intensified intervention aimed at multiple risk factors favorably influences the development or progression of DSPN, as opposed to CAN, in type 2 diabetic patients. However, the Steno study used only vibration detection, which measures exclusively the changes in large-fiber function.

The presence of multiple comorbidities including other cardiovascular risk factors, weight gain, polypharmacy, varying DM treatment modalities, and the fact that hyperglycemia can go asymptomatic for many years before the recognition of T2DM and DSPN could have influenced the effects of glucose control in these studies (Ang et al. 2014). In the Bypass Angioplasty Revascularization Investigation in Type 2 Diabetes (BARI 2D) study, T2DM men treated with insulin sensitizers had a lower incidence of DSPN over 4 years than those treated with insulin/sulfonylurea. This outcome may be a result of less weight gain and less hypoglycemia (Pop-Busui et al. 2013a).

## Oxidative Stress

A number of studies have shown that hyperglycemia causes oxidative stress in tissues that are susceptible to complications of diabetes, including peripheral nerves. Figure 2 presents our current understanding of the mechanisms and potential therapeutic pathways for oxidative stress-induced nerve damage. Studies show that hyperglycemia induces an increased presence of markers of oxidative stress, such as superoxide and peroxynitrite ions, and that antioxidant defense moieties are reduced in patients with diabetic peripheral neuropathy (Ziegler et al. 2004a). Several therapies known to reduce oxidative stress have been tested, including aldose reductase inhibitors (ARIs),  $\alpha$ -lipoic acid,  $\gamma$ -linolenic acid, benfotiamine, and protein kinase C (PKC) inhibitors. With the exception of  $\alpha$ -lipoic acid, none of these compounds have been successful in reversing or mitigating the progression of DSPN.

**Alpha-lipoic acid** (ALA) has been used for its antioxidant properties and for its thiol replenishing redox-modulating properties. A number of studies show its



favorable influence on microcirculation and reversal of symptoms of neuropathy (Ametov et al. 2003; Ruhnau et al. 1999; Ziegler et al. 1995; Reljanovic et al. 1999). A meta-analysis including 1258 patients from 4 randomized clinical trials concluded that 600 mg of i.v.  $\alpha$ -lipoic acid daily significantly reduced symptoms of neuropathy and improved neuropathic deficits (Ziegler et al. 2004b). The SYDNEY 2 trial showed significant improvement in neuropathic symptoms and neurologic deficits in 181 diabetic patients with three different doses of  $\alpha$ -lipoic acid compared to placebo over a 5-week period (Ziegler et al. 2006). The long-term effects of oral  $\alpha$ -lipoic acid on electrophysiology and clinical assessments were examined during the NATHAN 1 study, which showed that 4 years of treatment with  $\alpha$ -lipoic acid in mild to moderate DSPN is well tolerated and improves neuropathic deficits, symptoms, and measures of heart rate variability (HRV) but not nerve conduction (Ziegler et al. 2011). Recently, Ziegler and colleagues analyze the impact of baseline factors on the efficacy of  $\alpha$ -lipoic acid (ALA) over 4 years in the NATHAN 1 trial. Better outcome in neuropathic impairments was predicted by older age, lower BMI, male sex, normal blood pressure, history of CVD, insulin treatment, longer duration of diabetes and neuropathy, and higher neuropathy stage, while improvement in cardiac autonomic function was predicted by ACE inhibitor treatment. This suggests that optimal control of CVD risk factors could contribute to improved efficacy of  $\alpha$ -lipoic acid in patients with higher disease burden (Ziegler et al. 2016).

### Growth Factors

There is increasing evidence that there is a deficiency of nerve growth factor (NGF) in diabetes, as well as the dependent neuropeptide substance P (SP) and calcitonin gene-related peptide (CGRP), and that this contributes to the clinical perturbations in small-fiber function (Pittenger and Vinik 2003). Clinical trials with NGF have not been successful but are subject to certain caveats with regard to design; however, NGF still holds promise for sensory and autonomic neuropathies (Vinik 1999). The pathogenesis of DN includes loss of vasa nervorum, so it is likely that appropriate application of vascular endothelial growth factor (VEGF) would reverse the dysfunction. Introduction of VEGF gene into the muscle of DM animal models improved nerve function (Rivard et al. 1999). Hepatocyte growth factor (Kessler et al. 2015; Ajroud-Driss et al. 2013) (HGF) is another potent angiogenic cytokine under study for the treatment of painful neuropathy. In a phase II, double-blind, placebo-controlled trial including 104 patients, HGF (VM202) showed significant reduction in pain scores at 3 months, which persisted at 6 and 9 months, although not reaching significance (Fig. 11). VM202 was safe, well tolerated, and effective indicating the feasibility of a nonviral gene therapy approach to painful diabetic neuropathy (Kessler et al. 2015). A phase III trial is currently underway. INGAP peptide comprises the core active sequence of islet neogenesis-associated protein (INGAP), a pancreatic cytokine that can induce new islet formation and restore euglycemia in diabetic rodents. Maysinger et al. showed significant improvement in thermal hypoalgesia in diabetic mice after a 2-week treatment with INGAP peptide (Tam et al. 2004).

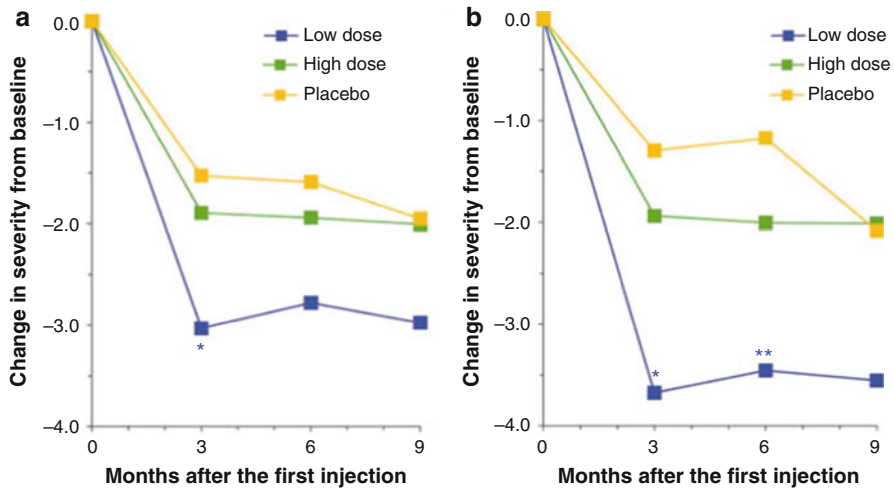

**Fig. 11** Phase II double-blind, placebo-controlled study of hepatocyte growth factor (HGF) gene therapy in diabetic neuropathy (Kessler et al. 2015). Mean pain scores on the daily pain diary expressed as change from baseline. (a) Scores for all patients in the efficacy population. The low-dose (LD) group differed significantly from the P group at 3 months ( $*P = 0.04$ ) by ANOVA with Dunnett's post hoc test. (b) Scores for subgroup patients not taking gabapentin or pregabalin. The LD group differed significantly from the P group both at 3 months ( $*P = 0.007$ ) and at 6 months ( $**P = 0.005$ )

## Treatment of Symptoms and Improvement in QoL

### The Diagnostic Workup for Pain

Pain is the reason for 40% of patient visits in a primary care setting, and about 20% of these have had pain for greater than 6 months (Mantyselka et al. 2001). Chronic pain may be nociceptive which occurs as a result of disease or damage to tissue wherein there is no abnormality in the nervous system or there may be no somatic abnormality. In contrast neuropathic pain is "pain arising as a direct consequence of a lesion or disease affecting the somatosensory system" (Treede et al. 2008). Persistent neuropathic pain interferes significantly with quality of life (QoL), impairing sleep and recreation; it also significantly impacts emotional well-being and is associated with if not the cause of depression, anxiety, loss of sleep, and noncompliance with treatment (Jensen et al. 2007). Neuropathy pain is a difficult-to-manage clinical problem. It is often associated with mood and sleep disturbances, and patients with pain are more apt to seek medical attention than those with other types of diabetic neuropathy. Two population-based studies showed that neuropathic pain is associated with a greater psychological burden than nociceptive pain (Bouhassira et al. 2008) and is considered to be more severe than other pain types. Early recognition of psychological problems is critical to the management of pain, and physicians need to go beyond the management of pain per se if they are to achieve success. Patients may also complain of decreased physical activity and mobility, increased

fatigue, and negative effects on their social lives. Providing significant pain relief markedly improves quality-of-life measures, including sleep and vitality (Vinik et al. 2005, 2008a).

Because of its complexity, the presentation of pain poses a diagnostic dilemma for the clinician. It is imperative to try to establish the nature of any predisposing factor including the pathogenesis of the pain if one is to be successful in its management. Management of neuropathic pain requires a sound relationship between patient and physician, with an emphasis on a positive outlook and encouragement that there is a solution. This requires patience and targeted pain-centered strategies that deal with the underlying disorder rather than the usual Band-Aid prescription of drugs approved for general pain, which do not address the disease process. The inciting injury may be focal or diffuse and may involve single or, more likely, multiple mechanisms such as metabolic disturbances encompassing hyperglycemia, dyslipidemia, glucose fluctuations, or intensification of therapy with insulin. On the other hand, the injury might embrace autoimmune mechanisms, neurovascular insufficiency, deficient neurotrophism, oxidative and nitrosative stress, or inflammation (Vinik et al. 2006). Because pain syndromes in diabetes may be focal or diffuse, proximal or distal, and acute or chronic, each has its own pathogenesis, and the treatment must be tailored to the underlying disorder if the outcome is to be successful.

### **Pathogenetic Mechanism of Neuropathic Pain**

Neuropathic pain could arise from neuronal dysfunctions all along the somatosensory system from its most peripheral part, i.e., the nociceptor terminal membrane, to the cortical neurons. Nerve damage may induce peripheral sensitization. This is related to the release of inflammatory mediators which activate intracellular signal transduction pathways in the nociceptor terminal, prompting an increase in the production, transport, and membrane insertion of transducer channels and voltage-gated ion channels (Costigan et al. 2009; Baron 2006). Following nerve injury, different types of voltage-gated sodium channels are upregulated at the site of the lesion and in the dorsal root ganglion membrane, promoting ectopic spontaneous activity along the primary afferent neuron and determining hyperexcitability associated with lowered activation threshold, hyper-reactivity to stimuli, and abnormal release of neurotransmitters such as substance P and glutamate (Baron 2006; Cruccu et al. 2010; Rolke et al. 2006; Cole 2007; Veves et al. 2008). As a consequence of this hyperactivity in primary afferent nociceptive neurons, important secondary changes may occur in the dorsal horn of the spinal cord and higher up in the central nervous system leading to neuron hyperexcitability. This phenomenon, called central sensitization, is a form of use-dependent synaptic plasticity, considered a major pathophysiological mechanism of neuropathic pain (Fig. 12) (Costigan et al. 2009). Different studies have demonstrated that thalamic dysfunction occurs in patients with diabetes as well as in experimental models (Fischer and Waxman 2010). Cortical disinhibition has also been demonstrated in patients with painful diabetic peripheral neuropathy (PDPN) using the transcranial magnetic stimulation technique (Turgut and Altun 2009). In addition, nerve injury appears to suspend the

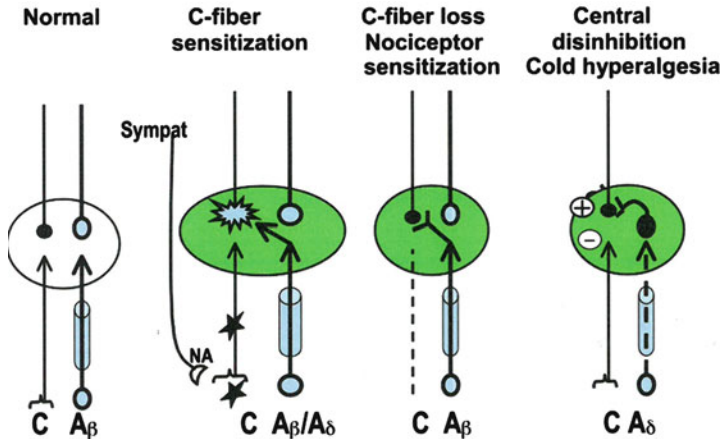

**Fig. 12** Schematic representation of the generation of pain (Vinik et al. 2006). (a) Normal: Central terminals of c-afferents project into the dorsal horn and make contact with secondary pain-signaling neurons. Mechanoreceptive A $\beta$  afferents project without synaptic transmission into the dorsal columns (not shown) and also contact secondary afferent dorsal horn neurons. (b) C-fiber sensitization: Spontaneous activity in peripheral nociceptors (peripheral sensitization, black stars) induces changes in the central sensory processing, leading to spinal cord hyperexcitability (central sensitization, gray star) that causes input from mechanoreceptive A $\beta$  (light touch) and A $\delta$ -fibers (punctuate stimuli) to be perceived as pain (allodynia). (c) C-fiber loss: C-nociceptor degeneration and novel synaptic contacts of A $\beta$  fibers with “free” central nociceptive neurons, causing dynamic mechanical allodynia. (d) Central disinhibition: Selective damage of cold-sensitive A $\delta$ -fibers that leads to central disinhibition, resulting in cold hyperalgesia. Sympat, sympathetic nerve

inhibitory modulation exerted by noradrenergic descending pathways, letting facilitatory modulation by serotonergic descending pathways prevail. Finally, pre- and postsynaptic GABAergic inhibition is lost, and this may produce paradoxical excitation, contributing to neuron hyperexcitability and even to spontaneous neuron activity (Costigan et al. 2009).

### Distinction Between Nociceptive and Non-nociceptive Pains

A number of tools have been developed to differentiate non-nociceptive stimuli (allodynia), increased pain sensitivity to stimuli (hyperalgesia) (Loeser and Treede 2008), and summation, which is progressive worsening of pain caused by repeated mild noxious stimuli (Bennett et al. 2007). Self-administered questionnaires have been developed, validated, translated, and subjected to cross-cultural adaptation both to diagnose and distinguish neuropathic as opposed to non-neuropathic pain (screening tools such as the Leeds Assessment of Neuropathic Symptoms and Signs (LANSS) Pain Scale, Douleur Neuropathique en 4 Questions (DN4), Neuropathic Pain Questionnaire (NPS), Pain DETECT, and ID-Pain) (Bennett et al. 2005, 2007; Bouhassira et al. 2004, 2005; Krause and Backonja 2003; Freyhagen et al. 2006; Portenoy 2006) and to assess pain quality and intensity such as the short-form McGill Pain Questionnaire, the Brief Pain

Inventory (BPI), and the Neuropathic Pain Symptom Inventory (NPSI) (Bouhassira et al. 2004; Dworkin et al. 2009; Daut et al. 1983). According to the Initiative on Methods, Measurement, and Pain Assessment in Clinical Trials (IMMPACT), the following pain characteristics should be evaluated to assess the efficacy and effectiveness of chronic pain treatment: (1) pain intensity measured on a 0–10 numerical rating scale (NRS); (2) physical functioning assessed by the Multi-dimensional Pain Inventory (MPI) and Brief Pain Inventory (BPI) Interference scale; (3) emotional functioning, assessed by the Beck Depression Inventory (BPI) and Profile of Mood States; and (4) patient rating of overall improvement, assessed by the Patient Global Impression of Change (PGIC) (Dworkin et al. 2008). Evaluation of pain intensity is essential for monitoring response to therapy. There are a number of symptom-based screening tools such as the NTSS-6, Brief Pain Inventory, and Visual Analog Scale for Pain Intensity and Neuropathy Symptoms Score (NSS) (Casellini and Vinik 2007). Simultaneously, the patient should complete a quality-of-life tool such as the Norfolk QoL-DN, SF-36, or Neuro-QoL, which needs to include comorbidities such as anxiety, depression, and sleep interference (Vinik et al. 2005). Such a tool permits evaluation of the impact of the pain on quality of life (QoL), anxiety, and depression, all of which are known to be accompanying features of PDPN.

### **Pain and Its Comorbidities**

Several studies have consistently found that neuropathic pain has a negative impact on global health-related quality of life. A systematic review of 52 studies in patients with 1 out of 6 different disorders associated with neuropathic pain, including PDPN, established that neuropathic pain impairs physical and emotional functioning, role functioning including participation in gainful employment and sleep, and, to a lesser degree, social functioning. In addition, there is also evidence suggesting an association between neuropathic pain and depression, as for other types of pain (Jensen et al. 2007; O'Connor 2009). The impact of pain on quality of life (QoL) in PDPN has been shown in 1111 patients: physical and mental QoL were significantly more impaired in patients with PDPN versus both diabetic patients devoid of neuropathy and those with non-painful DSPN (Ziegler et al. 2008a). Also the nature of pain may be important, as Daousi et al. have reported significantly poorer QoL in patients with PDPN versus diabetic patients with non-neuropathic pain (Daousi et al. 2004). Targeted studies in diabetic patients have shown that (1) chronic and severe pain significantly interferes with overall diabetes self-management and (2) neuropathic pain significantly interferes with the quality of sleep measured by the Medical Outcomes Study Sleep Scale (MOS-Sleep Scale) (Krein et al. 2005; Zelman et al. 2006).

Neuropathic pain, if inadequately treated, may lead to anxiety, depression, catastrophizing behavior (an inability to accept chronic pain), and sleep disturbances. Treatment of peripheral neuropathic pain conditions can benefit from further understanding of the impact of pain improvement on QoL including ADLs and sleep. Castro and Daltro (2009) studied 400 patients with depression, anxiety, and sleep disturbances. Two thirds of the depressed patients had pain; three quarters of the

anxious patients did so too; but the group worst affected by pain were the sleep-deprived patients, of whom >90% had experienced pain. As a corollary, Gore et al. (2005) showed that with increasing pain severity, there was a linear increase in HADS pain and depression scores. Depression complicated diabetes management, increased the length of hospital stays, and almost doubled the yearly cost of diabetes management from \$7000 to \$11,000 (Boulangier et al. 2009). Moreover, Gupta et al. showed that higher scores for anxiety, depression, and sleep disturbances predicted the development of pain (Gupta et al. 2007). Vinik et al. examined data from five DPN, four postherpetic neuralgia (PHN), and one DPN/PHN double-blind, placebo-controlled, randomized clinical trial of a 8–13-week duration. The data showed a direct relationship between the reduction in pain and enhanced sleep and improvement in social functioning on the SF-36 scale. Indeed, the improvement in social functioning depended equally on pain relief and sleep improvement. In addition, the effects of pregabalin on pain relief were mediated directly and indirectly through its effects on sleep improvement (Vinik et al. 2010b). This speaks to the need for determining sleep status in the evaluation of pain and choosing an agent capable of enhancing sleep if pain relief is to be achieved.

### **Epidemiology of Neuropathic Pain**

Neuropathic pain is not uncommon. A population-based survey of 6000 patients treated in family practice in the UK reported a 6% prevalence of pain predominantly of neuropathic origin (Torrance et al. 2006). A recent observational study of a large cohort of diabetic patients in Northwest England ( $n = 15,692$ ) concluded that one third of all community-based diabetic patients have painful neuropathy symptoms, regardless of their neuropathic deficit. PDPN was more prevalent in patients with type 2 diabetes, women, and people of South Asian origin (Abbott et al. 2011). This study shows a significant morbidity due to painful neuropathy and identifies key groups who warrant screening for PDPN. Similarly a large population-based study in France showed that 6.9% of the population had neuropathic pain (Bouhassira et al. 2008). Interestingly, in a Dutch population survey of >362,000 persons, younger people with pain tended to be mostly women, but with advancing age, the gender differences disappeared (Dieleman et al. 2008) which when recognized is readily amenable to intervention (Cornblath et al. 2007). Even more salutary is the mounting evidence that even with impaired glucose tolerance (IGT), patients may experience pain (Ziegler et al. 2008a, 2009b; Smith et al. 2006). In the general population (region of Augsburg, Southern Germany), the prevalence of painful PN was 13.3% in the diabetic subjects, 8.7% in those with IGT, 4.2% in those with impaired fasting glucose (IFG), and 1.2% in those with normal glucose tolerance (NGT) (Ziegler et al. 2009a). Among survivors of myocardial infarction (MI) from the Augsburg MI Registry, the prevalence of neuropathic pain was 21.0% in diabetic subjects, 14.8% in IGT, 5.7% in IFG, and 3.7% in NGT (Ziegler et al. 2009b). The most important risk factors of DSPN and neuropathic pain in these surveys were age, obesity, and low physical activity, while the predominant comorbidity was peripheral arterial disease, highlighting the paramount role of cardiovascular risk factors and diseases in prevalent DSPN.

## The Diagnosis of Neuropathic Pain

The diagnosis of neuropathic pain – as opposed to pain from causes other than neuropathy – is first and foremost made by careful history taking. Pain in the first three fingers is carpal tunnel syndrome; pain in the pinky is ulnar entrapment; pain on the lateral side of the shin is peroneal entrapment; pain on the medial side of the foot is medial plantar entrapment; and pain in the space between the first and second metatarsal heads is a Morton's neuroma. Somatosensory, motor, and autonomic bedside evaluation can be done and is complimented by the use of one of the screening tools listed above (DN4, Pain DETECT) (Bennett et al. 2007). The physician should ensure that all the features of pain such as distribution, quality, severity, timing, associated symptoms, and exacerbating and alleviating factors (if any) are recorded. In particular, the presence of numbness, burning, tingling, lightning pain, stabbing, and prickling should be recorded, as is done in the Norfolk QoL-DN (Vinik et al. 2005), the NTSS-6 (Bastyr et al. 2002), and the Pain Detect (Bennett et al. 2007). Secondly, pain intensity and quality should be assessed, using pain intensity scales (Visual Analog Scale or NRS) (Scholz et al. 2009) and pain questionnaires (BPI, NPSI). A number of tools and questionnaires have been developed to quantify the pain impact on sleep, mood, and QoL, mainly to be used in clinical trials. In clinical practice, the Brief Pain Inventory, the Profile of Mood States, or the Hospital Anxiety and Depression Scale (HADS) can provide a simple measure of pain impact on QoL. Responses to treatment by self-reporting using a diary can document the course of painful symptoms and their impact on daily life (Spallone 2009). Diaries are also most useful for outcome measures and extensively used in clinical trials on drugs for pain relief.

## Management of Neuropathic Pain

Control of pain is one of the most difficult management issues in PDPN. It often involves different classes of drugs and requires combination therapies. In any painful syndrome, special attention to the underlying condition is essential for the overall management and for differentiation from other conditions that may coexist in patients with diabetes. A careful history of the nature of pain, its exact location, and detailed examination of the lower limbs are mandatory to ascertain alternate causes of pain. Pain can be caused by dysfunction of different types of small nerve fibers (A $\delta$ -fiber vs. C-fiber) that are modulated by sympathetic input with spontaneous firing of different neurotransmitters to the dorsal root ganglia, spinal cord, and cerebral cortex. Figure 12 describes the pathophysiological basis for the generation of neuropathic pain. Different types of pain respond to different types of therapies. Figure 13 describes the different nerve fibers affected and possible targeted treatments (Vinik et al. 2006).

## Pharmacological Treatment of Pain

Painful symptoms in DSPN may constitute a considerable management problem. The efficacy of a single therapeutic agent is not the rule, and simple analgesics are usually inadequate to control the pain (Finnerup et al. 2005, 2010; Dworkin et al. 2007, 2010; Vinik 2010; Vinik and Casellini 2013; Finnerup et al. 2015). Effective

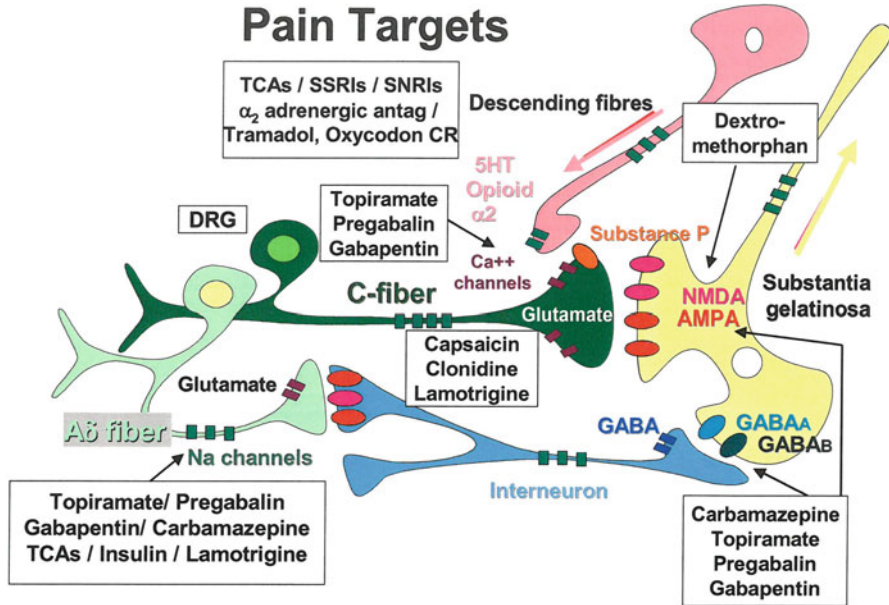

**Fig. 13** Different mechanisms of pain and possible treatments (Vinik et al. 2006). C-fibers are modulated by sympathetic input with spontaneous firing of different neurotransmitters to the dorsal root ganglia, spinal cord, and cerebral cortex. Sympathetic blockers (e.g., clonidine) and depletion of axonal substance P used by C-fibers as their neurotransmitter (e.g., by capsaicin) may improve pain. In contrast A $\delta$ -fibers utilize Na<sup>+</sup> channels for their conduction, and agents that inhibit Na<sup>+</sup> exchange such as antiepileptic drugs, tricyclic antidepressants, and insulin may ameliorate this form of pain. Anticonvulsants (carbamazepine, gabapentin, pregabalin, topiramate) potentiate activity of g-aminobutyric acid and inhibit Na<sup>+</sup> and Ca<sup>2+</sup> channels, N-methyl-D-aspartate receptors, and  $\alpha$ -amino-3-hydroxy-5-methyl-4-isoxazole propionic acid receptors. Dextromethorphan blocks N-methyl-D-aspartate receptors in the spinal cord. Tricyclic antidepressants, selective serotonin reuptake inhibitors (e.g., fluoxetine), and serotonin and norepinephrine reuptake inhibitors inhibit serotonin and norepinephrine reuptake, enhancing their effect in endogenous pain-inhibitory systems in the brain. Tramadol is a central opioid analgesic.  $\alpha_2$  antag  $\alpha_2$  antagonists, 5HT 5-hydroxytryptamine, AMPA  $\alpha$ -amino-3-hydroxy-5-methyl-4-isoxazole propionic acid, DRG dorsal root ganglia, GABA g-aminobutyric acid, NMDA N-methyl-D-aspartate, SNRIs serotonin and norepinephrine reuptake inhibitors, SP substance P, SSRIs selective serotonin reuptake inhibitors, TCAs tricyclic antidepressants

pain treatment considers a favorable balance between pain relief and side effects. The following general considerations in the pharmacotherapy of neuropathic pain require attention:

- The appropriate and effective drug has to be tried and identified in each patient by carefully titrating the dose based on efficacy and side effects.
- Lack of efficacy should be judged only after 2–4 weeks of treatment using an adequate dose.
- Because the evidence from clinical trials suggests only a maximum response of  $\approx 50\%$  for any monotherapy, analgesic combinations may be useful.



- Potential drug interactions have to be considered given the frequent use of polypharmacy in diabetic patients.

The relative benefit of an active treatment over a control in clinical trials is usually expressed as the relative risk, the relative risk reduction, or the odds ratio. However, to estimate the extent of a therapeutic effect (i.e., pain relief) that can be translated into clinical practice, it is useful to apply a simple measure that serves the physician in selecting the appropriate treatment for the individual patient. Such a practical measure is the “number needed to treat” (NNT), i.e., the number of patients who need to be treated with a particular therapy to observe a clinically relevant effect or adverse event in one patient. This measure is expressed as the reciprocal of the absolute risk reduction, i.e., the difference between the proportion of events in the control group ( $P_c$ ) and the proportion of events in the intervention group ( $P_i$ ):  $NNT = 1/(P_c - P_i)$ . The 95% confidence interval (CI) of NNT can be obtained from the reciprocal value of the 95% CI for the absolute risk reduction. The NNT and NNH (number needed to harm) for the individual agents used in the treatment of painful diabetic neuropathy are given in Table 6. Usually, drugs with NNTs exceeding six for  $\geq 50\%$  pain relief are regarded as showing limited efficacy. However, some authors have cautioned that summary NNT estimates may have limited clinical relevance, due to problems of heterogeneity (Edelsberg and Oster 2009).

During the last decade, several guidelines, recommendations, and systematic reviews have been published (Pop-Busui et al. 2017; Handelsman et al. 2015; Vinik and Casellini 2013; Bril et al. 2011; Tesfaye et al. 2011; Griebeler et al. 2014). Although there is general agreement among these, there are also some discrepancies. In this chapter, we will summarize the evidence available on the most effective treatments for PDPN. Currently only pregabalin and duloxetine have been approved by the US Food and Drug Administration (FDA), the European Medical Association, and the Health Canada. Tapentadol, a centrally acting opioid, has also recently been approved by the FDA.

## Topical Agents

**Topical capsaicin:** C-fibers utilize the neuropeptide substance P as their neurotransmitter, and depletion of axonal substance P (through the use of capsaicin) will often lead to amelioration of the pain. Prolonged application of capsaicin depletes stores of substance P, and possibly other neurotransmitters, from sensory nerve endings. This reduces or abolishes the transmission of painful stimuli from the peripheral nerve fibers to the higher centers (Rains and Bryson 1995). An analysis of randomized and controlled studies revealed that either a repeated application of low doses of capsaicin or single application of high doses affords pain relief (Derry et al. 2009). Several studies have demonstrated significant pain reduction and improvement in quality of life in diabetic patients with painful neuropathy after 8 weeks of treatment with capsaicin cream 0.075% (Mason et al. 2004). Treatment should be restricted to a maximum of 8 weeks, as during this period no adverse effect on sensory function (due to the mechanism of action) was noted in diabetic patients. The 8% capsaicin patch (Qutenza), which is effective in postherpetic neuralgia (Backonja et al. 2008),

**Table 6** Treatment options for painful DSPN, dosing, NNT, and side effects<sup>a</sup> (Vinik 2016)

Drug class and agent	Dose		Effective	NNT for improvement of 50% in one person <sup>b</sup>	Common adverse events <sup>c</sup>	Serious adverse events <sup>d</sup>
	Initial					
<b>Anticonvulsants</b>						
Pregabalin (LYRICA) <sup>e</sup>	25–75 mg, 1–3 times/day	300–600 mg/day	7.7 (6.5–9.4)	Somnolence, dizziness, peripheral edema, headache, ataxia, fatigue, xerostomia, weight gain	Angioedema, hepatotoxicity, rhabdomyolysis, seizures after abrupt discontinuation, suicidal thoughts and behavior, thrombocytopenia	
Gabapentin (Neurontin)	100–300 mg, 1–3 times/day	900–3600 mg/day	6.3 (5.0–8.3)	Somnolence, dizziness, ataxia, fatigue, weight gain	Seizures after rapid discontinuation, Stevens-Johnson syndrome, suicidal thoughts and behavior	
Topiramate (TOPAMAX)	25 mg/day	25–100 mg/day	No estimate <sup>f</sup>	Metabolic acidosis, paresthesia, somnolence, dizziness, anorexia, cognitive dysfunction, tremor, changes in taste	Glaucoma, hypokalemia, nephrolithiasis, osteomalacia, Stevens-Johnson syndrome, suicidality, toxic epidermal necrolysis	
<b>Antidepressants</b>						
Serotonin norepinephrine reuptake inhibitors (SNRIs)						
Duloxetine (Cymbalta) <sup>e</sup>	20–30 mg/day	60–120 mg/day	6.4 (5.2–8.4)	Nausea, somnolence, dizziness, constipation, dyspepsia, diarrhea, xerostomia, anorexia, headache, diaphoresis, insomnia, fatigue, decreased libido, shift to mania in	Bone fractures, cardiac arrhythmias, delirium, gastrointestinal hemorrhage, glaucoma, hepatotoxicity, hypertensive crisis, myocardial infarction, neuroleptic malignant	

				patients with bipolar disorder	syndrome, Stevens-Johnson syndrome, seizures, serotonin syndrome, severe hyponatremia, suicidal thoughts and behavior
Venlafaxine (Effexor)	37.5 mg/day	75–225 mg/day	4.5 <sup>e</sup>	Nausea, somnolence, dizziness, constipation, dyspepsia, diarrhea, xerostomia, anorexia, headache, diaphoresis, insomnia, fatigue, decreased libido	Bone fractures, cardiac arrhythmias, delirium, gastrointestinal hemorrhage, glaucoma, hepatotoxicity, hypotensive crisis, myocardial infarction, neuroleptic malignant syndrome, Stevens-Johnson syndrome, seizures, serotonin syndrome, severe hyponatremia, suicidal thoughts and behavior
Tricyclic agents (TCAs)					
Amitriptyline (Elavil)	10–25 mg/day	25–150 mg/day	3.6 (2.1–4.4)	Xerostomia, somnolence, fatigue, headache, dizziness, insomnia, orthostasis with conduction block, hypotension, anorexia, nausea, urinary retention, constipation, blurred vision, accommodation disturbance, mydriasis, weight gain	Bone fractures, bone marrow suppression, fragility, hepatotoxicity, neuroleptic malignant syndrome, serotonin syndrome, severe hyponatremia, shift to mania in patients with bipolar disorder, suicidal thoughts and behavior
Nortriptyline (Pamelor)	25–50 mg at bedtime	Increase from 25 to 50 mg/day every 2–3 days to maximum of 150 mg/day	No estimate <sup>f</sup>	Fewer anticholinergic effects than with amitriptyline	

*(continued)*

Table 6 (continued)

Drug class and agent	Dose		Effective	NNT for improvement of 50% in one person <sup>b</sup>	Common adverse events <sup>c</sup>	Serious adverse events <sup>d</sup>
	Initial					
<b>Opioids</b>						
Tapentadol (Nucynta) <sup>e, h</sup>	Immediate release, 50–100 mg, 4–6 times/day; extended release, 50 mg, 2 times/day	Immediate release, day 1: 700 mg, after day 1 60 mg/day; extended release, 50 mg 2 times/day	10.2 (5.3–18.5)	Somnolence, nausea, vomiting, constipation, dizziness, respiratory depression, serotonin syndrome, seizures	Hypertension, neonatal opioid-withdrawal syndrome	
Tramadol (Ultram) <sup>h</sup>	50 mg, 1–2 times/day	100–200 mg/day	4.7 (3.6–6.7)	Somnolence, nausea, vomiting, constipation, light headedness, dizziness, headache	Cardiac arrhythmias, confusion, hypersensitivity reactions, hypertension, seizures, Stevens-Johnson syndrome	

**Topical agents**

Capsaicin 8.0% patch (Qutenza)	Apply for 30 min	Apply for 60 min	10.0 (7.4–19)	Burning at site of application	Damage to C-type fibers, with loss of sensation
--------------------------------	------------------	------------------	---------------	--------------------------------	---

<sup>a</sup>The data reported are based on the findings of 12 studies of amitriptyline, 3 studies of nortriptyline, 9 studies of duloxetine, 4 studies of venlafaxine, 25 studies of pregabalin, 14 studies of gabapentin, 6 studies of gabapentin ER (extended release), 3 studies of topiramate, 7 studies of tramadol, 12 studies of tapentadol, and 7 studies of the capsaicin 8% patch and were adapted from Vinik13 and Finnerup et al. (Ryan et al. 2006)

<sup>b</sup>The Food and Drug Administration (FDA) also considers an improvement of 30% to be significant. NNT denotes number needed to treat. Numbers in parentheses represent the range

<sup>c</sup>Common adverse events are generally listed according to frequency

<sup>d</sup>Serious adverse events are listed alphabetically

<sup>e</sup>This drug has been approved for this indication by the FDA

<sup>f</sup>Studies of topiramate and nortriptyline were too small to provide an NNT

<sup>g</sup>No range is provided because the numbers were based on one study

<sup>h</sup>This drug is generally not used for first-line therapy

is contraindicated in painful diabetic neuropathy due to desensitization of nociceptive sensory nerve endings which may theoretically increase the risk of diabetic foot ulcers (Level Ib, Grade B). However, this has been challenged, and most recently, it has been shown that to repeat treatment with the capsaicin 8% patch over 52 weeks in patients with PDPN was well tolerated and not associated with impaired sensation. Indeed, pain relief was sustained for the duration of the study (Vinik et al. 2016). A recent Cochrane Review concluded that high-concentration topical capsaicin used to treat PDPN generated moderate to substantial levels of pain relief when compared to control treatment. These results should be interpreted with caution as the quality of the evidence was moderate to low. The additional proportion that benefited over control was not large, but for those who did obtain high levels of pain relief, there were usually additional improvements in comorbidities, including sleep, fatigue, depression, and quality of life. High-concentration topical capsaicin is similar in its effects to other therapies for chronic pain (Derry et al. 2017).

## Opioids

**Tramadol** is a centrally acting weak opioid analgesic for use in treating moderate to severe pain. Tramadol was shown to be better than placebo in two large randomized controlled trials for at least 6 months (Harati et al. 1998, 2000; Freeman et al. 2007). Side effects are, however, relatively common and are similar to other opioid-like drugs. Because the development of tolerance and dependence during long-term tramadol treatment is uncommon and its abuse liability appears to be low, it is an alternative to strong opioids in neuropathic pain (Harati et al. 1998).

**Oxycodone:** More severe pain requires administration of strong opioids such as controlled-release oxycodone. Although there is little data available on combination treatment, combinations of different substance classes have to be used in patients with pain resistant to monotherapy. Several add-on trials have demonstrated significant pain relief and improvement in quality of life following treatment with controlled-release oxycodone, a pure  $\mu$ -agonist in patients with painful DSPN whose pain was not adequately controlled on standard treatment with antidepressants and anticonvulsants (Watson et al. 2003; Gilron et al. 2005; Gimbel et al. 2003; Hanna et al. 2008). As expected, adverse events were frequent and typical of opioid-related side effects.

**Tapentadol** is a novel centrally acting opioid analgesic with a dual mode of action:  $\mu$ -opioid receptor agonist and norepinephrine reuptake inhibitor. Two recent multicenter, randomized, placebo-controlled trials evaluated the safety and efficacy of tapentadol extended release (ER) in painful diabetic DSPN. Both trials used an enriched design in which only responders at the end of a 3-week open-label titration phase were randomized to receive placebo or active drug over 12 weeks. Compared with placebo, tapentadol ER 100–250 mg bid was associated with a statistically significant difference in the maintenance of the initial improvement of pain and was well tolerated (Schwartz et al. 2011; Vinik et al. 2014). Tapentadol ER has received FDA approval for the treatment of painful DSPN. However, due to this design, a recent systematic review by the International Association for the Study of Pain Special Interest Group on Neuropathic Pain (NeuPSIG) found the evidence of the

effectiveness of tapentadol in reducing neuropathic pain inconclusive (Finnerup et al. 2015).

Whatever the case, and despite their effectiveness in the treatment of pain, opioids increase the risk of sedation, addiction, abuse, depression, and other psychosocial issues. Treatment of painful DSPN with opioid agonists should generally be reserved for patients who have failed to respond to or cannot tolerate first- and second-line agents, and referral to specialized pain clinics is recommended.

### **Antidepressants and Monoamine Reuptake Inhibitors**

Clinical trials have focused on interrupting pain transmission utilizing antidepressant drugs that inhibit the reuptake of norepinephrine or serotonin. This central action accentuates the effects of these neurotransmitters, essentially activating endogenous pain-inhibitory systems in the brain that modulate pain transmission cells in the spinal cord (Max et al. 1992). Putative mechanisms of pain relief by antidepressants include the inhibition of norepinephrine and/or serotonin reuptake at synapses of central descending pain control systems and the antagonism of *N*-methyl-D-aspartate receptors that mediate hyperalgesia and allodynia.

#### **Tricyclic Antidepressants (TCAs)**

Imipramine, amitriptyline, and clomipramine induce a balanced reuptake inhibition of both norepinephrine and serotonin, while desipramine is a relatively selective norepinephrine inhibitor. The NNT (CI) for  $\geq 50\%$  pain relief by TCAs in painful neuropathies is 2.1 (1.9–2.6). The number needed to harm (NNH) in patients with neuropathic pain for one dropout of the study due to adverse events is 16 (Geijselaers et al. 2015; van den Berg et al. 2006; Allen et al. 2004; Stewart and Liolitsa 1999; Ott et al. 1996; Lindsay et al. 1997; Yoshitake et al. 1995; Gustafson 2006; Bordier et al. 2014; Strachan and Price 2014; Punthakee et al. 2012; Ryan et al. 2006; Cukierman-Yaffe et al. 2009; Kloppenborg et al. 2008; Samaras and Sachdev 2012; Strachan 2011; Finnerup et al. 2010).

**Amitriptyline** is most widely used of the TCA for the treatment of PDPN. Some randomized, blinded, placebo-controlled trials have reported on the efficacy of amitriptyline for neuropathic pain (Max et al. 1987, 1992; Morello et al. 1999; Biesbroeck et al. 1995; Boyle et al. 2012). The starting dose of amitriptyline should be 25 mg (10 mg in frail patients) taken as a single nighttime dose 1 h before sleep. It should be increased by 25 mg at weekly intervals until pain relief is achieved or adverse events occur. The maximum dose is usually 150 mg per day. A recent Cochrane Systematic Review concluded that there is no clear evidence of the beneficial effect of amitriptyline for PDPN due to the small sample size of most of these trials, especially when balanced against adverse events (Finnerup et al. 2015).

**Nortriptyline and desipramine** are usually better tolerated and have fewer side effects than amitriptyline and imipramine and are usually preferable to use in the elderly, more frail patients. However, few randomized controlled trials have been done with these agents to consistently prove its efficacy (Max et al. 1991; Sindrup and Jensen 2000; Joss 1999; Hearn et al. 2014; Derry et al. 2015).

The most frequent adverse events of TCAs include tiredness and dry mouth. TCAs should be used with caution in patients with orthostatic hypotension and are contraindicated in patients with unstable angina, recent (<6 months) myocardial infarction, heart failure, history of ventricular arrhythmias, significant conduction system disease, and long QT syndrome. This is due to reports suggesting that there is an increase in the risk of myocardial ischemia and arrhythmias with the use of TCAs (Glassman et al. 1993; Ray et al. 2004).

### **Selective Serotonin Reuptake Inhibitors (SSRIs)**

Because of the relatively high rates of adverse effects and several contraindications of TCAs, it has been reasoned that patients who do not tolerate them due to adverse events could alternatively be treated with selective serotonin reuptake inhibitors (SSRIs). SSRIs specifically inhibit presynaptic reuptake of serotonin but not norepinephrine; and unlike the tricyclics, they lack the postsynaptic receptor-blocking effects and quinidine-like membrane stabilization. Unfortunately, only weak effects on neuropathic pain were observed after treatment with fluoxetine, paroxetine, citalopram, and escitalopram. The NNT (CI) for  $\geq 50\%$  pain relief by SSRIs in painful neuropathies is 6.8 (3.9–27) (Finnerup et al. 2010). Because of these limited efficacy data, SSRIs have not been approved for the treatment of neuropathic pain.

### **Serotonin Noradrenaline Reuptake Inhibitors (SNRIs)**

Because SSRIs have been found to be less effective than TCAs, recent interest has focused on antidepressants with dual selective inhibition of serotonin and noradrenaline such as duloxetine and venlafaxine.

**Duloxetine:** The efficacy and safety of duloxetine were evaluated in three controlled studies using a dose of 60 and 120 mg/day over 12 weeks (Kajdasz et al. 2007; Ziegler et al. 2007; Goldstein et al. 2005; Wernicke et al. 2006). In all three studies, the average 24 h pain intensity was significantly reduced with both doses as compared to placebo treatment, the difference between active and placebo achieving statistical significance after 1 week. The response rates, defined as  $\geq 50\%$  pain reduction, were 48.2% (120 mg/day), 47.2% (60 mg/day), and 27.9% (placebo), giving an NNT of 4.9 (95% CI, 3.6–7.6) for 120 mg/day and 5.3 (3.8–8.3) for 60 mg/day. Pain severity, but not variables related to diabetes or neuropathy, predicts the effects of duloxetine in diabetic peripheral neuropathic pain. Patients with higher pain intensity tend to respond better than those with lower pain levels (Ziegler et al. 2007). Duloxetine reduced interference with general activity and improved SF-36 and EQ-5D™ scores in two of the three clinical trials (Goldstein et al. 2005; Wernicke et al. 2006). The most frequent side effects of duloxetine include nausea, somnolence, dizziness, constipation, dry mouth, and reduced appetite. These adverse events are usually mild to moderate and transient. To minimize them, the starting dose should be 30 mg/day for 4–5 days. However, physicians must be aware about the possibility of orthostatic hypotension during the first week of treatment on the 30 mg dose. In contrast to TCAs and some anticonvulsants, duloxetine does not cause weight gain, but a small increase in fasting blood glucose may occur (Hardy et al. 2007).

**Venlafaxine** is another SNRI that has mixed action on catecholamine uptake. At lower doses, it inhibits serotonin uptake and at higher doses it inhibits norepinephrine uptake (Sansone and Sansone 2008). The extended release version of venlafaxine was found to be superior to placebo in diabetic neuropathic pain in non-depressed patients at doses of 150–225 mg daily, and when added to gabapentin, there was improved pain, mood, and quality of life (Simpson 2001). In a 6-week trial comprised of 244 patients, the analgesic response rates were 56%, 39%, and 34% in patients given 150–225 mg venlafaxine, 75 mg venlafaxine, and placebo, respectively. Because patients with depression were excluded, the effect of venlafaxine (150–225 mg) was attributed to an analgesic, rather than antidepressant, effect. The most common adverse events were tiredness and nausea (Rowbotham et al. 2004); additionally, clinically important electrocardiogram changes were found in seven patients in the treatment arm. Venlafaxine may lower the seizure threshold so gradual tapering is recommended.

### **Calcium Channel Modulators (Gabapentin and Pregabalin)**

Five types of voltage-gated calcium channels have been identified, and the L- and N-types of channels have a role to play in the neuromodulation of sensory neurons of the spinal cord. Gabapentin and pregabalin are medications that bind at the  $\alpha$ 2- $\delta$  subunits of the channels. Unlike traditional calcium channel antagonists, they do not block calcium channels but modulate their activity and sites of expression.

**Gabapentin** is an anticonvulsant structurally related to  $\gamma$ -aminobutyric acid (GABA), a neurotransmitter that plays a role in pain transmission and modulation and demonstrates high affinity binding to the  $\alpha$ 2- $\delta$  subunit of voltage-activated calcium channels. Several randomized and open-label trials have shown the efficacy of gabapentin in the treatment of PDPN (Morello et al. 1999; Simpson 2001; Backonja and Glanzman 2003; Backonja et al. 1998; Dallochio et al. 2000). In an 8-week multicenter dose-escalation trial including 165 diabetic patients with painful neuropathy, 60% of the patients on gabapentin had at least moderate pain relief compared to 33% on placebo. Dizziness and somnolence were the most frequent adverse events, occurring in about 23% of the patients in each group (Backonja et al. 1998). The NNT (CI) for  $\geq 50\%$  pain relief by gabapentin in painful neuropathies is 6.4 (4.3–12). Due to this relatively high NNT and publication bias toward unpublished negative trials (Landefeld and Steinman 2009), the overall level of evidence in favor of gabapentin in painful DSPN is weak. Gabapentin has the additional benefit of improving sleep (Backonja et al. 1998), which is often compromised in patients with chronic pain. Over the long term, it is known to produce weight gain, which may complicate diabetes management (DeToledo et al. 1997).

**Pregabalin** is a more specific  $\alpha$ 2- $\delta$  ligand with a sixfold higher binding affinity than gabapentin. Four clinical studies evaluated the efficacy of pregabalin (Lesser et al. 2004; Richter et al. 2005; Rosenstock et al. 2004; Freynhagen et al. 2005). All studies found that pregabalin relieved pain, but the effect size was small relative to



placebo, reducing pain by 11–13% on the 11-point Likert scale in three of them. A large dose-dependent effect (24–50% reduction in Likert pain scores compared to placebo) was observed in the fourth study (Freynhagen et al. 2005). The NNT from these studies for a 50% reduction in pain was 4 at 600 mg/day (Lesser et al. 2004; Richter et al. 2005; Rosenstock et al. 2004; Freynhagen et al. 2005). QoL measures, social functioning, mental health, bodily pain, and vitality improved, and sleep interference decreased, all significantly. The efficacy and safety of pregabalin were further reported in a pooled analysis of 7 studies over 5–11 weeks in 1346 diabetic patients with painful neuropathy (Freeman et al. 2008). The response rates defined as  $\geq 50\%$  pain reduction were 46% (600 mg/day), 39% (300 mg/day), 27% (150 mg/day), and 22% (placebo), giving an NNT of 4.2, 5.9, and 20.0. The most frequent side effects for 150–600 mg/day are dizziness (22.0%), somnolence (12.1%), peripheral edema (10.0%), headache (7.2%), and weight gain (5.4%) (Freeman et al. 2008). The evidence supporting a favorable effect in painful diabetic neuropathy is more solid, and dose titration is considerably easier for pregabalin than gabapentin (Bril et al. 2011). As mentioned before, we pooled and analyzed data from 11 randomized, double-blind, placebo-controlled trials of pregabalin for the treatment of DPN (5 trials) (Lesser et al. 2004; Richter et al. 2005; Rosenstock et al. 2004; Tolle et al. 2008; Arezzo et al. 2008), PHN (4 trials) (Sabatowski et al. 2004; Dworkin et al. 2003; van Seventer et al. 2006), and DPN/PHN (1 trial) (Freynhagen et al. 2005). In each trial, patients received either pregabalin or placebo for 8–13 weeks. In total, 921 patients received placebo and 1735 patients received pregabalin. Significant improvements over placebo were evident for the social functioning, role-emotional, mental health, bodily pain, vitality, and general health domains of the SF-36 (Vinik et al. 2010b). Overall patient status/quality of life, as assessed by PGIC scores, was also improved in response to pregabalin treatment. All pregabalin treatment arms also significantly improved both mean pain- and pain-related sleep interference scores compared to placebo. SF-36 domains exhibited at least a moderate negative linear relationship (correlation coefficient =  $-0.3$ ) with pain relief, meaning that SF-36 domain scores increased as mean pain scores decreased (Vinik et al. 2010b). Overall, these findings demonstrate that, in patients with chronic pain due to DPN or PHN, pregabalin-mediated improvements in patient function/quality of life are correlated with the extent of pain relief. However, such improvements are not mediated entirely through pain relief but rather the result of a combination of pregabalin's effects on pain and sleep disturbance and a direct effect on patient function itself (Vinik et al. 2010b). On the other hand, pregabalin has shown not to be effective when treating patients with advanced and severe neuropathic pain (Quilici et al. 2009; Ziegler et al. 2015b).

A recent meta-analysis comparing the efficacy of pregabalin and duloxetine (the two FDA-approved drugs for the treatment of PDPN) did not show any significant difference between both agents (Quilici et al. 2009). Also, Tesfaye and colleagues in the recent COMBO-DN study found that, although not significantly superior to high-dose monotherapy, combination therapy with duloxetine and pregabalin was considered to be effective, safe, and well tolerated (Teskaye et al. 2013).

### **Sodium Channel Blockers (Carbamazepine, Oxcarbazepine, Lacosamide)**

Voltage-gated sodium channels are crucial determinants of neuronal excitability and signaling. After nerve injury, hyperexcitability and spontaneous firing develop at the site of injury and also in the dorsal root ganglion cell bodies. This hyperexcitability results at least partly from accumulation of sodium channels at the site of injury (Kalso 2005). Carbamazepine and oxcarbazepine are most effective against the “lightning” pain produced by such spontaneous neuronal firing (Dogra et al. 2005). Although carbamazepine has been widely used for treating neuropathic pain, it cannot be recommended in painful diabetic neuropathy due to very limited data. Its successor drug, oxcarbazepine, and other sodium channel blockers such as valproate, mexiletine, topiramate, and lamotrigine showed only marginal efficacy and have not been licensed for the treatment of painful diabetic neuropathy.

**Topiramate:** Although topiramate failed in three clinical trials, due to the use of the wrong endpoint (Vinik 2008), it has been shown to successfully reduce pain and induce nerve regeneration in small studies (Raskin et al. 2004). An open-label extension study of topiramate (up to 600 mg/day) in subjects with moderately to severely painful DPN suggested that pain relief was effective and the drug caused weight loss and improvement in lipid and blood pressure parameters. However, 39.5% of subjects discontinued, most often due to adverse events (Donofrio et al. 2005). Recently Boyd and colleagues have shown that relief of pain with topiramate treatment was associated with improvement in subjective and objective measures of nerve function including intraepidermal nerve fiber regeneration (Boyd et al. 2010), as well as indices of quality of life (Boyd et al. 2011).

The most recent ADA position statement on DN has issued the following recommendations in relation to pain management (Pop-Busui et al. 2017):

- Consider either pregabalin or duloxetine as the initial approach in the symptomatic treatment for neuropathic pain in diabetes.
- Gabapentin may also be used as an effective initial approach, taking into account patients’ socioeconomic status, comorbidities, and potential drug interactions.
- Although not approved by the US Food and Drug Administration, tricyclic antidepressants are also effective for neuropathic pain in diabetes but should be used with caution given the higher risk of serious side effects.
- Given the high risks of addiction and other complications, the use of opioids, including tapentadol or tramadol, is not recommended as first- or second-line agents for treating the pain associated with DSPN.

### **Natural Products**

**Metanx** is a nutritional food product containing L-methylfolate, pyridoxal 5'-phosphate, and methylcobalamin developed for the management of endothelial dysfunction. Metanx ingredients counteract endothelial nitric oxide synthase uncoupling and oxidative stress in vascular endothelium and peripheral nerves. Obrosova and colleagues conducted a 4-week, placebo-controlled study to evaluate

the effects of metanx on DPN in Zucker diabetic fatty (ZDF) rats. Compared to controls, metanx-treated groups showed a significant improvement in sensory NCV and thermal and mechanical hypoalgesia, in the absence of any reduction on hyperglycemia. Metanx also increased intraepidermal nerve fiber density on ZDF rats (Obrosova and Shevalye 2011). A 24-week placebo-controlled trial on the effects of metanx on 214 patients with established diabetic neuropathy was conducted by Fonseca and colleagues. The primary endpoint was vibration perception threshold which failed to achieve significance. However, the Neuropathy Total Symptom Score-6 (NTSS-6), which includes symptoms of numbness, tingling, aching, burning, lancinating pain, and allodynia, improved significantly at week 16 ( $p = 0.013$  vs. placebo) and week 24 ( $p = 0.033$ ). Moreover, there were significant improvements in the mental health component of the SF-36. This response occurred with <2% adverse events, mainly rash and GI upset, and was no greater than placebo (Fonseca et al. 2013).

### **Lifestyle Interventions**

Overall, lifestyle modifications concentrate on either exercise alone (aerobic and/or resistance training, supervised) or in combination with dietary modifications. There is no general consensus regarding dietary plans, and some advice to a more low-calorie, low-fat diet, while others recommend a Mediterranean diet with lower carbohydrate and higher fat content. Some studies have evaluated the effects of intensive lifestyle interventions on neuropathic complications of diabetes with salutatory results (Balducci et al. 2006; Carnethon et al. 2006; Gaede et al. 2003; Smith et al. 2006; Knowler et al. 2002; Singleton et al. 2014). The Diabetes Prevention Program showed improvement on measures of CAN (Carnethon et al. 2006), the IGT Neuropathy study showed improvement in measures of DSPN (Smith et al. 2006), and the University of Utah T2DM Study recently reported nerve regeneration on skin biopsies (Singleton et al. 2014).

### **Botulinum Toxin**

Botulinum toxin has been tried for trigeminal neuralgia (Piovesan et al. 2005) and has been shown to have long-lasting antinociceptive effects in carpal tunnel syndrome with no electrophysiologic restoration (Tsai et al. 2006). It may provide relief of neuropathic pain in diabetes through its modulatory effects on afferent sensory fiber firing. One small double-blind crossover trial of intradermal botulinum toxin type A in 18 patients with PDN demonstrated a significant reduction in pain and improvement in sleep quality (Yuan et al. 2009).

### **Psychological Support**

A psychological component to pain should not be underestimated. Patients need to be reassured that even severe pain may remit, particularly in poorly controlled patients with acute painful neuropathy or in those painful symptoms precipitated by intensive insulin treatment. Thus, an empathetic approach addressing the concerns and anxieties of patients with neuropathic pain is essential for their successful management (Tesfaye 1998).

## Physical Measures

The temperature of the painful neuropathic foot may be increased due to arteriovenous shunting. Cold-water immersion may reduce shunt flow and relieve pain. Allodynia may be relieved by wearing silk pajamas or using bed cradle. Patients who describe painful symptoms on walking as comparable to walking on pebbles may benefit from the use of comfortable footwear (Tesfaye 1998).

## Acupuncture

A 10-week uncontrolled study with a follow-up period of 18–52 weeks in diabetic patients showed significant pain relief after up to six courses of traditional Chinese acupuncture without any side effects (Abuaisha et al. 1998). A single-blind placebo-controlled randomized trial of acupuncture in 45 subjects with PDN recently reported an improvement in the outcome measures assessing pain in the acupuncture arm relative to sham treatment (Garrow et al. 2014). However, Chen and colleagues warn that design flaws and lack of robust outcome measures of pain in acupuncture trials make meaningful conclusions difficult (Chen et al. 2013). Larger controlled studies are needed to confirm these early findings.

## Electrical Stimulation

Transcutaneous electrical nerve stimulation (TENS) influences neuronal afferent transmission and conduction velocity, increases the nociceptive flexion reflex threshold, and changes the somatosensory evoked potentials. In a 4-week study of TENS applied to the lower limbs, each for 30 min daily, pain relief was noted in 83% of the patients compared to 38% of a sham-treated group. In patients who only marginally responded to amitriptyline, pain reduction was significantly greater following TENS given for 12 weeks as compared with sham treatment. Thus, TENS may be used as an adjunctive modality combined with pharmacotherapy to augment pain relief (Kumar 1998).

Frequency-modulated electromagnetic nerve stimulation (FREMS) in two studies, including a recent double-blind randomized placebo-controlled trial with 51 weeks of follow-up, proved to be a safe treatment for symptomatic diabetic neuropathy, with immediate but transient reduction in pain and no effect on nerve conduction velocities (Bosi et al. 2005, 2013) (Level 11b, Grade B). Six out of eight trials analyzed in a recent review evaluating the use of electrical stimulation in PDN found significant pain relief in patients treated with electrical stimulation compared with placebo or sham treatment (Thakral et al. 2013).

In diabetic painful neuropathy that was unresponsive to drug treatment, electrical spinal cord stimulation (ESCS) with electrodes implanted between T9 and T11 resulted in a pain relief >50% in eight out of ten patients. In addition, exercise tolerance was significantly improved. Complications of ESCS included superficial wound infection in two patients, lead migration requiring reinsertion in two patients, and “late failure” after 4 months in a patient who had initial pain relief (Teskaye et al. 1996b). Two recent randomized trials of ESCS in patients with PDN showed significant symptomatic improvement in the majority of patients after 6 months; in

one trial, however, a patient randomized to ESCS died of a subdural hematoma (Slangen et al. 2014; De Vos et al. 2014). Currently, therefore, this invasive treatment option should be reserved for patients who do not respond to drug treatment (Level 1b, Grade B).

### Surgical Decompression

Surgical decompression at the site of anatomic narrowing has been promoted as an alternative treatment for patients with symptomatic DSPN. A systematic review of the literature revealed only class IV studies concerning the utility of this therapeutic approach. Given the current evidence available, this treatment alternative should be considered unproven (Level 1V, Grade CU). Prospective randomized controlled trials with standard definitions and outcome measures are necessary to determine the value of this therapeutic intervention (Chaudhry et al. 2006, 2008).

The odds ratios for efficacy and withdrawal from medications are given in Table 5 and Fig. 8. In addition, Tables 4, 6, and 7 show the dosages of the different drugs and the commonly encountered side effects.

### Guidelines for Treatment of Painful Neuropathy

Table 7 shows the treatment algorithm proposed by the Toronto Consensus Panel for the treatment of PDPN, which is similar to the one proposed by recent ADA position statement and AACE guidelines (Pop-Busui et al. 2017; Tesfaye et al. 2010; Handelsman et al. 2015). Figure 14 is an algorithm proposed for the management of painful neuropathy in diabetes, which takes into account comorbidities associated with chronic pain (Vinik 2010). These algorithms presume that the cause of the pain has been attributed to DN and that all causes masquerading as DN have been excluded. The identification of neuropathic pain as being focal or diffuse dictates the initial course of action. Focal neuropathic pain is best treated with diuretics to reduce edema in the canal, splinting, and surgery to release entrapment. Diffuse neuropathies are treated with medical therapy and in a majority of cases need multidrug therapy. Essential to the PDPN evaluation is the identification of the patient's comorbidities and the choice of drugs which can serve dual actions: e.g.,

**Table 7** Treatment algorithm for painful diabetic peripheral neuropathy (the Toronto Consensus Panel) (Teskaye et al. 2010)

<b>Painful diabetic neuropathy</b>			
<b>First line</b>	$\alpha$ 2- $\delta$ Agonist (pregabalin or gabapentin)	SNRI (duloxetine)	TCA
<b>If pain control is inadequate and considering contraindications</b>			
<b>Second line</b>	TCA or SNRI	TCA or $\alpha$ 2- $\delta$ agonist (pregabalin or gabapentin)	SNRI or $\alpha$ 2- $\delta$ agonist (pregabalin or gabapentin)
<b>If pain control is still inadequate</b>			
<b>Third line</b>	Add opioid agonist as combination therapy		

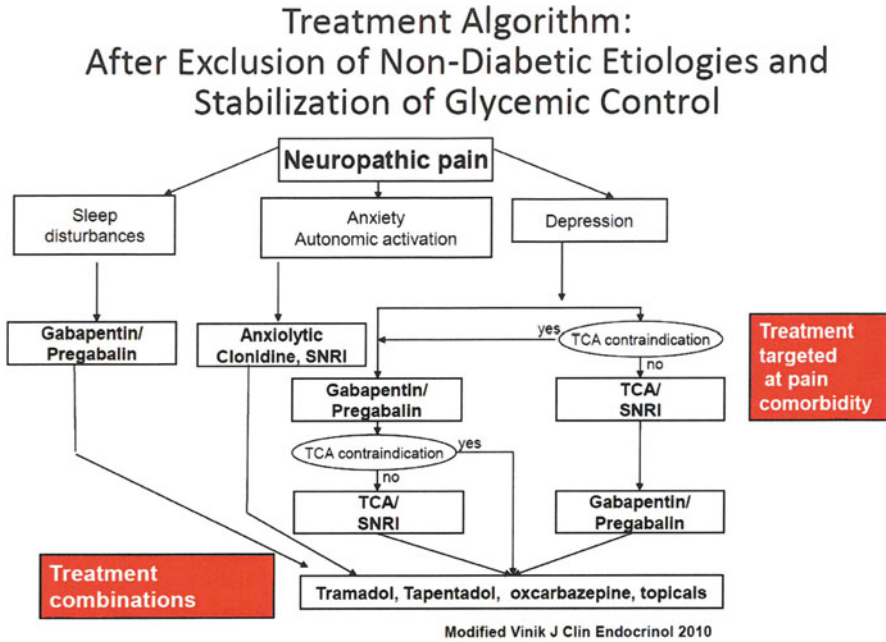

**Fig. 14** Treatment algorithm for the management of symptomatic diabetic neuropathy taking into account the presence of comorbidities (Vinik 2010). *SNRIs* serotonin-norepinephrine reuptake inhibitors, *TCA*s tricyclic antidepressants

pregabalin improves sleep and pain both by direct and indirect pathways, whereas duloxetine may reduce depression and anxiety which accompany pain. Immune-mediated neuropathies are treated with intravenous immunoglobulin, steroids, or other immunomodulators. When single agents fail, combinations of drugs with different mechanisms of action are in order. Comorbidities that accompany pain include depression, anxiety, and sleep disturbances, all of which must be addressed for successful management of pain. Treatment of peripheral neuropathic pain conditions can benefit from further understanding of the impact of pain response and QoL, including ADLs and sleep. As Winston Churchill said “We need to go from failure to failure without losing our enthusiasm and ultimately we will succeed. . .”

## References

- Abbott CA, Carrington AL, Ashe H, Bath S, Every LC, Griffiths J, et al. The North-West Diabetes Foot Care Study: incidence of, and risk factors for, new diabetic foot ulceration in a community-based patient cohort. *Diabet Med.* 2002;19(5):377–84.
- Abbott CA, Malik RA, Van Ross ER, Kulkarni J, Boulton AJ. Prevalence and characteristics of painful diabetic neuropathy in a large community-based diabetic population in the U.K. *Diabetes Care.* 2011;34(10):2220–4.

- Abuaisha BB, Costanzi JB, Boulton AJ. Acupuncture for the treatment of chronic painful peripheral diabetic neuropathy: a long-term study. *Diabetes Res Clin Pract.* 1998;39(2):115–21.
- Adkin AL, Frank JS, Carpenter MG, Peysar GW. Postural control is scaled to level of postural threat. *Gait Posture.* 2000;12(2):87–93.
- ADVANCE Collaborative Group. Intensive blood glucose control and vascular outcomes in patients with type 2 diabetes. *N Engl J Med.* 2008;358:2560–72.
- Ahmed A, Bril V, Orszag A, Paulson J, Yeung E, Ngo M, et al. Detection of diabetic sensorimotor polyneuropathy by corneal confocal microscopy in type 1 diabetes: a concurrent validity study. *Diabetes Care.* 2012;35(4):821–8.
- Ajroud-Driss S, Christiansen M, Allen JA, Kessler JA. Phase 1/2 open-label dose-escalation study of plasmid DNA expressing two isoforms of hepatocyte growth factor in patients with painful diabetic peripheral neuropathy. *Mol Ther.* 2013;21:1279.
- Albers JW, Pop-Busui R. Diabetic neuropathy: mechanisms, emerging treatments, and subtypes. *Curr Neurol Neurosci Rep.* 2014;14(8):473.
- Albers JW, Herman WH, Pop-Busui R, Feldman EL, Martin CL, Cleary PA, et al. Effect of prior intensive insulin treatment during the Diabetes Control and Complications Trial (DCCT) on peripheral neuropathy in type 1 diabetes during the Epidemiology of Diabetes Interventions and Complications (EDIC) Study. *Diabetes Care.* 2010;33(5):1090–6.
- Allen KV, Frier BM, Strachan MW. The relationship between type 2 diabetes and cognitive dysfunction: longitudinal studies and their methodological limitations. *Eur J Pharmacol.* 2004;490(1-3):169–75.
- Allet L, Armand S, de Bie RA, Golay A, Pataky Z, Aminian K, et al. Clinical factors associated with gait alterations in diabetic patients. *Diabet Med.* 2009;26(10):1003–9.
- Allet L, Armand S, de Bie RA, Golay A, Monnin D, Aminian K, et al. The gait and balance of patients with diabetes can be improved: a randomised controlled trial. *Diabetologia.* 2010; 53(3):458–66.
- American Diabetes Association. Standards of medical care in diabetes. *Diabetes Care.* 2013; 36(Suppl 1):S11.
- American Diabetes Association American Academy of Neurology. Consensus statement: Report and recommendations of the San Antonio conference on diabetic neuropathy. *Diabetes Care.* 1988;11(7):592–7.
- Ametov AS, Barinov A, Dyck PJ, Hermann R, Kozlova N, Litchy WJ, et al. The sensory symptoms of diabetic polyneuropathy are improved with alpha-lipoic acid: the SYDNEY trial. *Diabetes Care.* 2003;26(3):770–6.
- Ang L, Jaiswal M, Martin C, Pop-Busui R. Glucose control and diabetic neuropathy: lessons from recent large clinical trials. *Curr Diab Rep.* 2014;14(9):528.
- Apfel SC, Kessler JA, Adornato BT, Litchy WJ, Sanders C, Rask CA. Recombinant human nerve growth factor in the treatment of diabetic polyneuropathy. NGF Study Group. *Neurology.* 1998;51(3):695–702.
- Arezzo JC, Rosenstock J, LaMoreaux L, Pauer L. Efficacy and safety of pregabalin 600 mg/d for treating painful diabetic peripheral neuropathy: a double-blind placebo-controlled trial. *BMC Neurol.* 2008;8:33.
- Asghar O, Petropoulos IN, Alam U, Jones W, Jeziorska M, Marshall A, et al. Corneal confocal microscopy detects neuropathy in subjects with impaired glucose tolerance. *Diabetes Care.* 2014;37(9):2643–6.
- Aung PP, Strachan MW, Frier BM, Butcher I, Deary IJ, Price JF. Severe hypoglycaemia and late-life cognitive ability in older people with Type 2 diabetes: the Edinburgh Type 2 Diabetes Study. *Diabet Med.* 2012;29(3):328–36.
- Ayyar DR, Sharma KR. Chronic inflammatory demyelinating polyradiculoneuropathy in diabetes mellitus. *Curr Diab Rep.* 2004;4(6):409–12.
- Azmi S, Ferdousi M, Petropoulos IN, Ponirakis G, Alam U, Fadavi H, et al. Corneal confocal microscopy identifies small-fiber neuropathy in subjects with impaired glucose tolerance who develop type 2 diabetes. *Diabetes Care.* 2015;38(8):1502–8.
- Backonja M, Glanzman RL. Gabapentin dosing for neuropathic pain: evidence from randomized, placebo-controlled clinical trials. *Clin Ther.* 2003;25(1):81–104.

- Backonja M, Beydoun A, Edwards KR, Schwartz SL, Fonseca V, Hes M, et al. Gabapentin for the symptomatic treatment of painful neuropathy in patients with diabetes mellitus: a randomized controlled trial. *JAMA*. 1998;280(21):1831–6.
- Backonja M, Wallace MS, Blonsky ER, Cutler BJ, Malan P Jr, Rauck R, et al. NGX-4010, a high-concentration capsaicin patch, for the treatment of postherpetic neuralgia: a randomised, double-blind study. *Lancet Neurol*. 2008;7(12):1106–12.
- Backonja MM, Attal N, Baron R, Bouhassira D, Drangholt M, Dyck PJ, et al. Value of quantitative sensory testing in neurological and pain disorders: NeuPSIG consensus. *Pain*. 2013;154(9):1807–19.
- Baeuerle PA, Baltimore D. NF-kappa B: ten years after. *Cell*. 1996;87(1):13–20.
- Bakkers M, Merckies IS, Lauria G, Devigili G, Penza P, Lombardi R, et al. Intraepidermal nerve fiber density and its application in sarcoidosis. *Neurology*. 2009;73(14):1142–8.
- Balducci S, Iacobellis G, Parisi L, Di BN, Calandriello E, Leonetti F, et al. Exercise training can modify the natural history of diabetic peripheral neuropathy. *J Diabetes Complicat*. 2006;20(4):216–23.
- Banks WA. The source of cerebral insulin. *Eur J Pharmacol*. 2004;490(1–3):5–12.
- Barada A, Reljanovic M, Milicevic Z, Ljubic S, Car N, Benko B, et al. Proximal diabetic neuropathy-response to immunotherapy. *Diabetes*. 1999;48(Suppl 1):A148.
- Barnett A, Smith B, Lord SR, Williams M, Baumand A. Community-based group exercise improves balance and reduces falls in at-risk older people: a randomised controlled trial. *Age Ageing*. 2003;32(4):407–14.
- Baron R. Mechanisms of disease: neuropathic pain – a clinical perspective. *Nat Clin Pract Neurol*. 2006;2(2):95–106.
- Baron R, Tolle TR, Gockel U, Brosz M, Freynhagen R. A cross-sectional cohort survey in 2100 patients with painful diabetic neuropathy and postherpetic neuralgia: differences in demographic data and sensory symptoms. *Pain*. 2009;146(1–2):34–40.
- Bastyr E, Zhang D, Bril V, The MBBQ Study Group. Neuropathy Total symptom Score-6 Questionnaire (NTSS-6) is a valid instrument for assessing the positive symptoms of diabetic peripheral neuropathy (DPN). *Diabetes*. 2002;51:A199.
- Benedict C, Hallschmid M, Schmitz K, Schultes B, Ratter F, Fehm HL, et al. Intranasal insulin improves memory in humans: superiority of insulin aspart. *Neuropsychopharmacology*. 2007;32(1):239–43.
- Bennett MI, Smith BH, Torrance N, Potter J. The S-LANSS score for identifying pain of predominantly neuropathic origin: validation for use in clinical and postal research. *J Pain*. 2005;6(3):149–58.
- Bennett MI, Attal N, Backonja MM, Baron R, Bouhassira D, Freynhagen R, et al. Using screening tools to identify neuropathic pain. *Pain*. 2007;127(3):199–203.
- Berlie HD, Garwood CL. Diabetes medications related to an increased risk of falls and fall-related morbidity in the elderly. *Ann Pharmacother*. 2010;44(4):712–7.
- Bernardi L, Spallone V, Stevens M, Hilsted J, Frontoni S, Pop-Busui R, et al. Methods of investigation for cardiac autonomic dysfunction in human research studies. *Diabetes Metab Res Rev*. 2011;27(7):654–64.
- Bierhaus A, Schiekofer S, Schwaninger M, Andrassy M, Humpert PM, Chen J, et al. Diabetes-associated sustained activation of the transcription factor nuclear factor-kappaB. *Diabetes*. 2001;50(12):2792–808.
- Biesbroeck R, Bril V, Hollander P, Kabadi U, Schwartz S, Singh SP, et al. A double-blind comparison of topical capsaicin and oral amitriptyline in painful diabetic neuropathy. *Adv Ther*. 1995;12(2):111–20.
- Biessels GJ, Reijmer YD. Brain changes underlying cognitive dysfunction in diabetes: what can we learn from MRI? *Diabetes*. 2014;63(7):2244–52.
- Biessels GJ, Bril V, Calcutt NA, Cameron NE, Cotter MA, Dobrowsky R, et al. Phenotyping animal models of diabetic neuropathy: a consensus statement of the diabetic neuropathy study group of the EASD (Neurodiab). *J Peripher Nerv Syst*. 2014;19(2):77–87.



- Bongaerts BW, Rathmann W, Heier M, Kowall B, Herder C, Stockl D, et al. Older subjects with diabetes and prediabetes are frequently unaware of having distal sensorimotor polyneuropathy: the KORA F4 study. *Diabetes Care*. 2013;36(5):1141–6.
- Bordier L, Doucet J, Boudet J, Bauduceau B. Update on cognitive decline and dementia in elderly patients with diabetes. *Diabetes Metab*. 2014;40(5):331–7.
- Borenstein J, Aronow HU, Bolton LB, Choi J, Bresee C, Braunstein GD. Early recognition of risk factors for adverse outcomes during hospitalization among Medicare patients: a prospective cohort study. *BMC Geriatr*. 2013;13:72.
- Bosi E, Conti M, Vermigli C, Cazzetta G, Peretti E, Cordoni MC, et al. Effectiveness of frequency-modulated electromagnetic neural stimulation in the treatment of painful diabetic neuropathy. *Diabetologia*. 2005;48(5):817–23.
- Bosi E, Bax G, Scionti L, Spallone V, Tesfaye S, Valensi P, et al. Frequency-modulated electromagnetic neural stimulation (FREMS) as a treatment for symptomatic diabetic neuropathy: results from a double-blind, randomised, multicentre, long-term, placebo-controlled clinical trial. *Diabetologia*. 2013;56(3):467–75.
- Boucher P, Teasdale N, Courtemanche R, Bard C, Fleury M. Postural stability in diabetic polyneuropathy. *Diabetes Care*. 1995;18(5):638–45.
- Bouhassira D, Attal N, Fermanian J, Alchaar H, Gautron M, Masquelier E, et al. Development and validation of the neuropathic pain symptom inventory. *Pain*. 2004;108(3):248–57.
- Bouhassira D, Attal N, Alchaar H, Boureau F, Brochet B, Bruxelle J, et al. Comparison of pain syndromes associated with nervous or somatic lesions and development of a new neuropathic pain diagnostic questionnaire (DN4). *Pain*. 2005;114(1–2):29–36.
- Bouhassira D, Lanteri-Minet M, Attal N, Laurent B, Touboul C. Prevalence of chronic pain with neuropathic characteristics in the general population. *Pain*. 2008;136(3):380–7.
- Boulanger L, Zhao Y, Foster TS, Fraser K, Bledsoe SL, Russell MW. Impact of comorbid depression or anxiety on patterns of treatment and economic outcomes among patients with diabetic peripheral neuropathic pain. *Curr Med Res Opin*. 2009;25(7):1763–73.
- Boulton AJ. The pathway to foot ulceration in diabetes. *Med Clin North Am*. 2013;97(5):775–90.
- Boulton AJ, Malik RA, Arezzo JC, Sosenko JM. Diabetic somatic neuropathies. *Diabetes Care*. 2004;27(6):1458–86.
- Boulton AJ, Vinik AI, Arezzo JC, Bril V, Feldman EL, Freeman R, et al. Diabetic neuropathies: a statement by the American Diabetes Association. *Diabetes Care*. 2005;28(4):956–62.
- Bourcier ME, Ullal J, Parson HK, Dublin CB, Witherspoon CA, Ward SA, et al. Diabetic peripheral neuropathy: how reliable is a homemade 1-g monofilament for screening? *J Fam Pract*. 2006;55(6):505–8.
- Boyd R, Stevens JA. Falls and fear of falling: burden, beliefs and behaviours. *Age Ageing*. 2009;38(4):423–8.
- Boyd AL, Barlow PM, Pittenger GL, Simmons KF, Vinik AI. Topiramate improves neurovascular function, epidermal nerve fiber morphology, and metabolism in patients with type 2 diabetes mellitus. *Diabetes Metab Syndr Obes*. 2010;3:431–7.
- Boyd A, Casellini C, Vinik E, Vinik A. Quality of life and objective measures of diabetic neuropathy in a prospective placebo controlled trial of ruboxistaurin and topiramate. *J Diabetes Sci Technol*. 2011;5(3):714–22.
- Boyle J, Eriksson ME, Gribble L, Gouni R, Johnsen S, Coppini DV, et al. Randomized, placebo-controlled comparison of amitriptyline, duloxetine, and pregabalin in patients with chronic diabetic peripheral neuropathic pain: impact on pain, polysomnographic sleep, daytime functioning, and quality of life. *Diabetes Care*. 2012;35(12):2451–8.
- Bril V. NIS-LL: the primary measurement scale for clinical trial endpoints in diabetic peripheral neuropathy. *Eur Neurol*. 1999;41(Suppl 1):8–13.
- Bril V, Perkins BA. Validation of the Toronto clinical scoring system for diabetic polyneuropathy. *Diabetes Care*. 2002;25(11):2048–52.
- Bril V, England J, Franklin GM, Backonja M, Cohen J, Del TD, et al. Evidence-based guideline: treatment of painful diabetic neuropathy: report of the American Academy of Neurology, the

- American Association of Neuromuscular and Electrodiagnostic Medicine, and the American Academy of Physical Medicine and Rehabilitation. *Neurology*. 2011;76(20):1758–65.
- Britland ST, Young RJ, Sharma AK, Clarke BF. Acute and remitting painful diabetic polyneuropathy: a comparison of peripheral nerve fibre pathology. *Pain*. 1992;48:361–70.
- Brown SJ, Handsaker JC, Bowling FL, Boulton AJ, Reeves ND. Diabetic peripheral neuropathy compromises balance during daily activities. *Diabetes Care*. 2015;38(6):1116–22.
- Brownlee M. The pathobiology of diabetic complications: a unifying mechanism. *Diabetes*. 2005;54(6):1615–25.
- Bruce DG, Davis WA, Casey GP, Clarnette RM, Brown SG, Jacobs IG, et al. Severe hypoglycaemia and cognitive impairment in older patients with diabetes: the Fremantle Diabetes Study. *Diabetologia*. 2009;52(9):1808–15.
- Callaghan BC, Kerber KA, Lisabeth LL, Morgenstern LB, Longoria R, Rodgers A, et al. Role of neurologists and diagnostic tests on the management of distal symmetric polyneuropathy. *JAMA Neurol*. 2014;71(9):1143–9.
- Callaghan BC, Xia R, Banerjee M, de Rekeneire N, Harris TB, Newman AB, et al. Metabolic syndrome components are associated with symptomatic polyneuropathy independent of glycemic status. *Diabetes Care*. 2016;39:801.
- Calvet JH, Dupin J, Winiacki H, Schwarz PEH. Assessment of small fiber neuropathy through a quick, simple and non invasive method in a German diabetes outpatient clinic. *Exp Clin Endocrinol Diabetes*. 2012;120:1–4.
- Cameron NE, Eaton SEM, Cotter MA, Tesfaye S. Vascular factors and metabolic interactions in the pathogenesis of diabetic neuropathy. *Diabetologia*. 2001;44:1973–88.
- Cameron FJ, Kean MJ, Wellard RM, Werther GA, Neil JJ, Inder TE. Insights into the acute cerebral metabolic changes associated with childhood diabetes. *Diabet Med*. 2005;22(5):648–53.
- Carnethon MR, Prineas RJ, Temprosa M, Zhang ZM, Uwaifo G, Molitch ME. The association among autonomic nervous system function, incident diabetes, and intervention arm in the Diabetes Prevention Program. *Diabetes Care*. 2006;29(4):914–9.
- Carpenter MG, Frank JS, Silcher CP, Peysar GW. The influence of postural threat on the control of upright stance. *Exp Brain Res*. 2001;138(2):210–8.
- Carvalho LA, Urbanova L, Hamer M, Hackett RA, Lazzarino AI, Steptoe A. Blunted glucocorticoid and mineralocorticoid sensitivity to stress in people with diabetes. *Psychoneuroendocrinology*. 2015;51:209–18.
- Casellini CM, Vinik AI. Clinical manifestations and current treatment options for diabetic neuropathies. *Endocr Pract*. 2007;13(5):550–66.
- Casellini CM, Parson HK, Richardson MS, Nevoret ML, Vinik AI. Sudoscan, a noninvasive tool for detecting diabetic small fiber neuropathy and autonomic dysfunction. *Diabetes Technol Ther*. 2013;15(11):948–53.
- Castro MM, Daltro C. Sleep patterns and symptoms of anxiety and depression in patients with chronic pain. *Arq Neuropsiquiatr*. 2009;67(1):25–8.
- Cavanagh PR, Simoneau GG, Ulbrecht JS. Ulceration, unsteadiness, and uncertainty: the biomechanical consequences of diabetes mellitus. *J Biomech*. 1993;26(Suppl 1):23–40.
- Chan YC, Lo YL, Chan ES. Immunotherapy for diabetic amyotrophy. *Cochrane Database Syst Rev*. 2012;6:CD006521.
- Chao CC, Hsieh SC, Yang WS, Lin YH, Lin WM, Tai TY, et al. Glycemic control is related to the severity of impaired thermal sensations in type 2 diabetes. *Diabetes Metab Res Rev*. 2007;23(8):612–20.
- Chaudhry V, Stevens JC, Kincaid J, So YT. Practice advisory: utility of surgical decompression for treatment of diabetic neuropathy: report of the Therapeutics and Technology Assessment Subcommittee of the American Academy of Neurology. *Neurology*. 2006;66(12):1805–8.
- Chaudhry V, Russell J, Belzberg A. Decompressive surgery of lower limbs for symmetrical diabetic peripheral neuropathy. *Cochrane Database Syst Rev*. 2008;16(3):CD006152.
- Chen W, Yang GY, Liu B, Manheimer E, Liu JP. Manual acupuncture for treatment of diabetic peripheral neuropathy: a systematic review of randomized controlled trials. *PLoS One*. 2013;8(9):e73764.

- Chen YC, Jiao Y, Cui Y, Shang SA, Ding J, Feng Y, et al. Aberrant brain functional connectivity related to insulin resistance in type 2 diabetes: a resting-state fMRI study. *Diabetes Care*. 2014;37(6):1689–96.
- Chen X, Graham J, Dabbah MA, Petropoulos IN, Ponirakis G, Asghar O, et al. Small nerve fiber quantification in the diagnosis of diabetic sensorimotor polyneuropathy: comparing corneal confocal microscopy with intraepidermal nerve fiber density. *Diabetes Care*. 2015; 38(6):1138–44.
- Chiles NS, Phillips CL, Volpato S, Bandinelli S, Ferrucci L, Guralnik JM, et al. Diabetes, peripheral neuropathy, and lower-extremity function. *J Diabetes Complicat*. 2014;28(1):91–5.
- Christmas C, Andersen RA. Exercise and older patients: guidelines for the clinician. *J Am Geriatr Soc*. 2000;48(3):318–24.
- Cohen E, Dillin A. The insulin paradox: aging, proteotoxicity and neurodegeneration. *Nat Rev Neurosci*. 2008;9(10):759–67.
- Colberg S. The impact of exercise on insulin action in type 2 diabetes mellitus: Relationship to prevention and control. *Insulin*. 2006;1(3):85–98.
- Colberg S, Stansberry K, McNitt P, Vinik A. Chronic exercise is associated with enhanced cutaneous blood flow in type 2 diabetes. *J Diabetes Complicat*. 2002;16:139–45.
- Colberg SR, Parson HK, Nunnold T, Holton DR, Swain DP, Vinik AI. Change in cutaneous perfusion following 10 weeks of aerobic training in type 2 diabetes. *J Diabetes Complicat*. 2005;19(5):276–83.
- Cole BE. Diabetic peripheral neuropathic pain: recognition and management. *Pain Med*. 2007;8(Suppl 2):S27–32.
- Consensus Report of the Peripheral Nerve Society. Diabetic polyneuropathy in controlled clinical trials. *Ann Neurol*. 1995;38(3):478–82.
- Cooper GJ, Leighton B, Dimitriadis GD, Parry Billings M, Kowalchuk JM, Howland K, et al. Amylin found in amyloid deposits in human type 2 diabetes mellitus may be a hormone that regulates glycogen metabolism in skeletal muscle. *Proc Natl Acad Sci U S A*. 1988;85(20): 7763–6.
- Coppin AK, Shumway-Cook A, Saczynski JS, Patel KV, Ble A, Ferrucci L, et al. Association of executive function and performance of dual-task physical tests among older adults: analyses from the InChianti study. *Age Ageing*. 2006;35(6):619–24.
- Comblath DR, Vinik A, Feldman E, Freeman R, Boulton AJ. Surgical decompression for diabetic sensorimotor polyneuropathy. *Diabetes Care*. 2007;30(2):421–2.
- Corriveau H, Prince F, Hebert R, Raiche M, Tessier D, Maheux P, et al. Evaluation of postural stability in elderly with diabetic neuropathy. *Diabetes Care*. 2000;23(8):1187–91.
- Costigan M, Scholz J, Woolf CJ. Neuropathic pain: a maladaptive response of the nervous system to damage. *Annu Rev Neurosci*. 2009;32:1–32.
- Cosway R, Strachan MW, Dougall A, Frier BM, Deary IJ. Cognitive function and information processing in type 2 diabetes. *Diabet Med*. 2001;18(10):803–10.
- Craft S, Baker LD, Montine TJ, Minoshima S, Watson GS, Claxton A, et al. Intranasal insulin therapy for Alzheimer disease and amnesic mild cognitive impairment: a pilot clinical trial. *Arch Neurol*. 2012;69:29.
- Crichton GE, Elias MF, Buckley JD, Murphy KJ, Bryan J, Frisardi V. Metabolic syndrome, cognitive performance, and dementia. *J Alzheimers Dis*. 2012;30(Suppl 2):S77–87.
- Criego AB, Tkac I, Kumar A, Thomas W, Gruetter R, Seaquist ER. Brain glucose concentrations in patients with type 1 diabetes and hypoglycemia unawareness. *J Neurosci Res*. 2005; 79(1–2):42–7.
- Cross DA, Alessi DR, Cohen P, Andjelkovich M, Hemmings BA. Inhibition of glycogen synthase kinase-3 by insulin mediated by protein kinase B. *Nature*. 1995;378(6559):785–9.
- Cruccu G, Sommer C, Anand P, Attal N, Baron R, Garcia-Larrea L, et al. EFNS guidelines on neuropathic pain assessment: revised 2009. *Eur J Neurol*. 2010;17(8):1010–8.
- Cruzat A, Qazi Y, Hamrah P. In vivo confocal microscopy of corneal nerves in health and disease. *Ocul Surf*. 2017;15(1):15–47.
- Cui Y, Jiao Y, Chen Y, Wang K, Gao B, Wen S, et al. Altered spontaneous brain activity in type 2 diabetes: a resting-state functional MRI study. *Diabetes*. 2014;63(2):749–60.

- Cukierman-Yaffe T, Gerstein HC, Williamson JD, Lazar RM, Lovato L, Miller ME, et al. Relationship between baseline glycemic control and cognitive function in individuals with type 2 diabetes and other cardiovascular risk factors: the action to control cardiovascular risk in diabetes-memory in diabetes (ACCORD-MIND) trial. *Diabetes Care*. 2009;32(2):221–6.
- Dabbah MA, Graham J, Petropoulos IN, Tavakoli M, Malik RA. Automatic analysis of diabetic peripheral neuropathy using multi-scale quantitative morphology of nerve fibres in corneal confocal microscopy imaging. *Med Image Anal*. 2011;15(5):738–47.
- Dabby R, Sadeh M, Lampl Y, Gilad R, Watemala N. Acute painful neuropathy induced by rapid correction of serum glucose levels in diabetic patients. *Biomed Pharmacother*. 2009;63(10):707–9.
- Dalocchio C, Buffa C, Mazzarello P, Chirotti S. Gabapentin vs. amitriptyline in painful diabetic neuropathy: an open-label pilot study. *J Pain Symptom Manag*. 2000;20(4):280–5.
- Daousi C, MacFarlane IA, Woodward A, Nurmikko TJ, Bundred PE, Benbow SJ. Chronic painful peripheral neuropathy in an urban community: a controlled comparison of people with and without diabetes. *Diabet Med*. 2004;21(9):976–82.
- Daut RL, Cleeland CS, Flanery RC. Development of the Wisconsin Brief Pain Questionnaire to assess pain in cancer and other diseases. *Pain*. 1983;17(2):197–210.
- Davies M, Brophy S, Williams R, Taylor A. The prevalence, severity, and impact of painful diabetic peripheral neuropathy in type 2 diabetes. *Diabetes Care*. 2006;29(7):1518–22.
- DCCT Research Group. The effect of intensive diabetes therapy on the development and progression of neuropathy. *Ann Intern Med*. 1995a;122:561–8.
- DCCT Research Group. Effect of intensive diabetes treatment on nerve conduction in the diabetes control and complications trial. *Ann Neurol*. 1995b;38:869.
- de Bresser J, Tiehuis AM, van den BE, Reijmer YD, Jongen C, Kappelle LJ, et al. Progression of cerebral atrophy and white matter hyperintensities in patients with type 2 diabetes. *Diabetes Care*. 2010;33(6):1309–14.
- de Galan BE, Zoungas S, Chalmers J, Anderson C, Dufouil C, Pillai A, et al. Cognitive function and risks of cardiovascular disease and hypoglycaemia in patients with type 2 diabetes: the Action in Diabetes and Vascular Disease: Preterax and Diamicron Modified Release Controlled Evaluation (ADVANCE) trial. *Diabetologia*. 2009;52(11):2328–36.
- De Vos CC, Meier K, Zaalberg PB, Nijhuis HJ, Duyvendak W, Vesper J, et al. Spinal cord stimulation in patients with painful diabetic neuropathy: a multicentre randomized clinical trial. *Pain*. 2014;155(11):2426–31.
- Dehghani C, Pritchard N, Edwards K, Russell AW, Malik RA, Efron N. Fully automated, semi-automated, and manual morphometric analysis of corneal subbasal nerve plexus in individuals with and without diabetes. *Cornea*. 2014;33(7):696–702.
- Delbaere K, Sturnieks DL, Crombez G, Lord SR. Concern about falls elicits changes in gait parameters in conditions of postural threat in older people. *J Gerontol A Biol Sci Med Sci*. 2009;64(2):237–42.
- Derry S, Lloyd R, Moore RA, McQuay HJ. Topical capsaicin for chronic neuropathic pain in adults. *Cochrane Database Syst Rev*. 2009;4:CD007393.
- Derry S, Wiffen PJ, Aldington D, Moore RA. Nortriptyline for neuropathic pain in adults. *Cochrane Database Syst Rev*. 2015;1:CD011209.
- Derry S, Rice AS, Cole P, Tan T, Moore RA. Topical capsaicin (high concentration) for chronic neuropathic pain in adults. *Cochrane Database Syst Rev*. 2017;1:CD007393.
- DeToledo JC, Toledo C, DeCerce J, Ramsay RE. Changes in body weight with chronic, high-dose gabapentin therapy. *Ther Drug Monit*. 1997;19(4):394–6.
- Dieleman JP, Kerklaan J, Huygen FJ, Bouma PA, Sturkenboom MC. Incidence rates and treatment of neuropathic pain conditions in the general population. *Pain*. 2008;137(3):681–8.
- Dogra S, Beydoun S, Mazzola J, Hopwood M, Wan Y. Oxcarbazepine in painful diabetic neuropathy: a randomized, placebo-controlled study. *Eur J Pain*. 2005;9(5):543–54.
- Donofrio PD, Raskin P, Rosenthal NR, Hewitt DJ, Jordan DM, Xiang J, et al. Safety and effectiveness of topiramate for the management of painful diabetic peripheral neuropathy in an open-label extension study. *Clin Ther*. 2005;27(9):1420–31.

- Dore S, Kar S, Quirion R. Insulin-like growth factor I protects and rescues hippocampal neurons against beta-amyloid- and human amylin-induced toxicity. *Proc Natl Acad Sci U S A*. 1997;94(9):4772–7.
- Duckworth W, Abraira C, Moritz T, Reda D, Emanuele N, Reaven PD, et al. Glucose control and vascular complications in veterans with type 2 diabetes. *N Engl J Med*. 2009;360(2):129–39.
- Dworkin RH, Corbin AE, Young JP Jr, Sharma U, LaMoreaux L, Bockbrader H, et al. Pregabalin for the treatment of postherpetic neuralgia: a randomized, placebo-controlled trial. *Neurology*. 2003;60(8):1274–83.
- Dworkin RH, O'Connor AB, Backonja M, Farrar JT, Finnerup NB, Jensen TS, et al. Pharmacologic management of neuropathic pain: evidence-based recommendations. *Pain*. 2007;132(3):237–51.
- Dworkin RH, Turk DC, Wyrwich KW, Beaton D, Cleeland CS, Farrar JT, et al. Interpreting the clinical importance of treatment outcomes in chronic pain clinical trials: IMMPACT recommendations. *J Pain*. 2008;9(2):105–21.
- Dworkin RH, Turk DC, Revicki DA, Harding G, Coyne KS, Peirce-Sandner S, et al. Development and initial validation of an expanded and revised version of the Short-form McGill Pain Questionnaire (SF-MPQ-2). *Pain*. 2009;144(1–2):35–42.
- Dworkin RH, O'Connor AB, Audette J, Baron R, Gourlay GK, Haanpaa ML, et al. Recommendations for the pharmacological management of neuropathic pain: an overview and literature update. *Mayo Clin Proc*. 2010;85(3 Suppl):S3–14.
- Dyck PJ, Windebank AJ. Diabetic and nondiabetic lumbosacral radiculoplexus neuropathies: new insights into pathophysiology and treatment. *Muscle Nerve*. 2002;25(4):477–91.
- Dyck PJ, Kratz KM, Karnes JL, Litchy WJ, Klein R, Pach JM, et al. The prevalence by staged severity of various types of diabetic neuropathy, retinopathy, and nephropathy in a population-based cohort: The Rochester Diabetic Neuropathy Study. *Neurology*. 1993;43:817–24.
- Dyck PJ, Overland CJ, Low PA, Litchy WJ, Davies JL, Dyck PJ, et al. Signs and symptoms versus nerve conduction studies to diagnose diabetic sensorimotor polyneuropathy: CI vs. NPhys trial. *Muscle Nerve*. 2010;42(2):157–64.
- Dyck PJ, Albers JW, Andersen H, Arezzo JC, Biessels GJ, Bril V, et al. Diabetic polyneuropathies: update on research definition, diagnostic criteria and estimation of severity. *Diabetes Metab Res Rev*. 2011;27(7):620–8.
- Dyer CA, Taylor GJ, Reed M, Dyer CA, Robertson DR, Harrington R. Falls prevention in residential care homes: a randomised controlled trial. *Age Ageing*. 2004;33(6):596–602.
- Eaton SE, Harris ND, Rajbhandari SM, Greenwood P, Wilkinson ID, Ward JD, et al. Spinal-cord involvement in diabetic peripheral neuropathy. *Lancet*. 2001;358(9275):35–6.
- Edelsberg J, Oster G. Summary measures of number needed to treat: how much clinical guidance do they provide in neuropathic pain? *Eur J Pain*. 2009;13:11–6.
- Edwards JL, Vincent AM, Cheng HT, Feldman EL. Diabetic neuropathy: mechanisms to management. *Pharmacol Ther*. 2008;120(1):1–34.
- Edwards K, Pritchard N, Vagenas D, Russell A, Malik RA, Efron N. Utility of corneal confocal microscopy for assessing mild diabetic neuropathy: baseline findings of the LANDMark study. *Clin Exp Optom*. 2012;95(3):348–54.
- Efron N, Edwards K, Roper N, Pritchard N, Sampson GP, Shahidi AM, et al. Repeatability of measuring corneal subbasal nerve fiber length in individuals with type 2 diabetes. *Eye Contact Lens*. 2010;36(5):245–8.
- Elias PK, Elias MF, D'Agostino RB, Cupples LA, Wilson PW, Silbershatz H, et al. NIDDM and blood pressure as risk factors for poor cognitive performance. The Framingham Study. *Diabetes Care*. 1997;20(9):1388–95.
- England JD, Gronseth GS, Franklin G, Carter GT, Kinsella LJ, Cohen JA, et al. Practice Parameter: evaluation of distal symmetric polyneuropathy: role of autonomic testing, nerve biopsy, and skin biopsy (an evidence-based review). Report of the American Academy of Neurology, American Association of Neuromuscular and Electrodiagnostic Medicine, and American Academy of Physical Medicine and Rehabilitation. *Neurology*. 2009;72(2):177–84.

- Enzinger C, Fazekas F, Matthews PM, Ropele S, Schmidt H, Smith S, et al. Risk factors for progression of brain atrophy in aging: six-year follow-up of normal subjects. *Neurology*. 2005;64(10):1704–11.
- Farooqi MA, Lovblom LE, Lysy Z, Ostrovski I, Halpern EM, Ngo M, et al. Validation of cooling detection threshold as a marker of sensorimotor polyneuropathy in type 2 diabetes. *J Diabetes Complicat*. 2016;30(4):716–22.
- Feil DG, Rajan M, Soroka O, Tseng CL, Miller DR, Pogach LM. Risk of hypoglycemia in older veterans with dementia and cognitive impairment: implications for practice and policy. *J Am Geriatr Soc*. 2011;59(12):2263–72.
- Feldman EL, Stevens MJ, Thomas PK, Brown MB, Canal N, Greene DA. A practical two-step quantitative clinical and electrophysiological assessment for the diagnosis and staging of diabetic neuropathy. *Diabetes Care*. 1994;17(11):1281–9.
- Fiatarone MA, O’Neill EF, Ryan ND, Clements KM, Solares GR, Nelson ME, et al. Exercise training and nutritional supplementation for physical frailty in very elderly people. *N Engl J Med*. 1994;330(25):1769–75.
- Finch CE, Cohen DM. Aging metabolism, and Alzheimer disease: review and hypotheses. *Exp Neurol*. 1997;143(1):82–102.
- Finnerup NB, Otto M, McQuay HJ, Jensen TS, Sindrup SH. Algorithm for neuropathic pain treatment: an evidence based proposal. *Pain*. 2005;118(3):289–305.
- Finnerup NB, Sindrup SH, Jensen TS. The evidence for pharmacological treatment of neuropathic pain. *Pain*. 2010;150(3):573–81.
- Finnerup NB, Attal N, Haroutounian S, McNicol E, Baron R, Dworkin RH, et al. Pharmacotherapy for neuropathic pain in adults: a systematic review and meta-analysis. *Lancet Neurol*. 2015;14:162–73.
- Fioretti S, Scocco M, Ladislao L, Ghetti G, Rabini RA. Identification of peripheral neuropathy in type-2 diabetic subjects by static posturography and linear discriminant analysis. *Gait Posture*. 2010;32(3):317–20.
- Fischer TZ, Waxman SG. Neuropathic pain in diabetes – evidence for a central mechanism. *Nat Rev Neurol*. 2010;6(8):462–6.
- Fonseca V, Lavery L, Thethi TK, et al. Metax in type 2 diabetes with peripheral neuropathy: a randomized trial. *Am J Med*. 2013;126(2):141–9.
- Francis GJ, Martinez JA, Liu WQ, Xu K, Ayer A, Fine J, et al. Intranasal insulin prevents cognitive decline, cerebral atrophy and white matter changes in murine type I diabetic encephalopathy. *Brain*. 2008;131(Pt 12):3311–34.
- Freedman BI, Bowden DW, Smith SC, Xu J, Divers J. Relationships between electrochemical skin conductance and kidney disease in type 2 diabetes. *J Diabetes Complicat*. 2014;28(1):56–60.
- Freedman BI, Smith SC, Bagwell BM, Xu J, Bowden DW, Divers J. Electrochemical skin conductance in diabetic kidney disease. *Am J Nephrol*. 2015;41(6):438–47.
- Freeman R, Raskin P, Hewitt DJ, Vorsanger GJ, Jordan DM, Xiang J, et al. Randomized study of tramadol/acetaminophen versus placebo in painful diabetic peripheral neuropathy. *Curr Med Res Opin*. 2007;23(1):147–61.
- Freeman R, Durso-Decruz E, Emir B. Efficacy safety, and tolerability of pregabalin treatment for painful diabetic peripheral neuropathy: findings from seven randomized, controlled trials across a range of doses. *Diabetes Care*. 2008;31(7):1448–54.
- Freeman R, Baron R, Bouhassira D, Cabrera J, Emir B. Sensory profiles of patients with neuropathic pain based on the neuropathic pain symptoms and signs. *Pain*. 2014;155(2):367–76.
- Freyhagen R, Baron R, Gockel U. Pain detect: a new screening questionnaire to detect neuropathic components in patients with back pain. *Curr Med Res Opin*. 2006;22:1911–20.
- Freyhagen R, Strojek K, Griesing T, Whalen E, Balkenohl M. Efficacy of pregabalin in neuropathic pain evaluated in a 12-week, randomised, double-blind, multicentre, placebo-controlled trial of flexible- and fixed-dose regimens. *Pain*. 2005;115(3):254–63.
- Frolich L, Blum-Degen D, Bernstein HG, Engelsberger S, Humrich J, Lauffer S, et al. Brain insulin and insulin receptors in aging and sporadic Alzheimer’s disease. *J Neural Transm (Vienna)*. 1998;105(4–5):423–38.

- Gaede P, Vedel P, Larsen N, Jensen GV, Parving HH, Pedersen O. Multifactorial intervention and cardiovascular disease in patients with type 2 diabetes. *N Engl J Med.* 2003;348(5):383–93.
- Gaede P, Lund-Andersen H, Parving HH, Pedersen O. Effect of a multifactorial intervention on mortality in type 2 diabetes. *N Engl J Med.* 2008;358(6):580–91.
- Ganz DA, Bao Y, Shekelle PG, Rubenstein LZ. Will my patient fall? *JAMA.* 2007;297(1):77–86.
- Garrow AP, Xing M, Vere J, Verrall B, Wang L, Jude EB. Role of acupuncture in the management of diabetic painful neuropathy (DPN): a pilot RCT. *Acupunct Med.* 2014;32(3):242–9.
- Geber C, Klein T, Azad S, Birklein F, Gierthmuhlen J, Hugel V, et al. Test-retest and interobserver reliability of quantitative sensory testing according to the protocol of the German Research Network on Neuropathic Pain (DFNS): a multi-centre study. *Pain.* 2011;152(3):548–56.
- Geijselaers SL, Sep SJ, Stehouwer CD, Biessels GJ. Glucose regulation, cognition, and brain MRI in type 2 diabetes: a systematic review. *Lancet Diabetes Endocrinol.* 2015;3(1):75–89.
- Gibbons CH. Small fiber neuropathies. *Continuum (Minneapolis, Minn).* 2014;20(5 Peripheral Nervous System Disorders):1398–412.
- Gibbons CH, Freeman R. Treatment-induced neuropathy of diabetes: an acute, iatrogenic complication of diabetes. *Brain.* 2015;138(Pt 1):43–52.
- Gillespie LD, Robertson MC, Gillespie WJ, Lamb SE, Gates S, Cumming RG, et al. Interventions for preventing falls in older people living in the community. *Cochrane Database Syst Rev.* 2009; Issue 2. Art. No.: CD007146. <https://doi.org/10.1002/14651858.CD007146.pub2>.
- Gilron I, Bailey JM, Tu D, Holden RR, Weaver DF, Houlden RL. Morphine, gabapentin, or their combination for neuropathic pain. *N Engl J Med.* 2005;352(13):1324–34.
- Gimbel JS, Richards P, Portenoy RK. Controlled-release oxycodone for pain in diabetic neuropathy: a randomized controlled trial. *Neurology.* 2003;60(6):927–34.
- Glassman AH, Roose SP, Bigger JT Jr. The safety of tricyclic antidepressants in cardiac patients. Risk-benefit reconsidered. *JAMA.* 1993;269(20):2673–5.
- Goldstein DJ, Lu Y, Detke MJ, Lee TC, Iyengar S. Duloxetine vs. placebo in patients with painful diabetic neuropathy. *Pain.* 2005;116(1-2):109–18.
- Gore M, Brandenburg NA, Dukes E, Hoffman DL, Tai KS, Stacey B. Pain severity in diabetic peripheral neuropathy is associated with patient functioning, symptom levels of anxiety and depression, and sleep. *J Pain Symptom Manag.* 2005;30(4):374–85.
- Grant WP, Sullivan R, Sonenshine DE, Adam M, Slusser JH, Carson KA, et al. Electron microscopic investigation of the effects of diabetes mellitus on the Achilles tendon. *J Foot Ankle Surg.* 1997;36(4):272–8.
- Gregg EW, Yaffe K, Cauley JA, Rolka DB, Blackwell TL, Narayan KM, et al. Is diabetes associated with cognitive impairment and cognitive decline among older women? Study of Osteoporotic Fractures Research Group. *Arch Intern Med.* 2000;160(2):174–80.
- Griebeler ML, Morey-Vargas OL, Brito JP, Tsapas A, Wang Z, Carranza Leon BG, et al. Pharmacologic interventions for painful diabetic neuropathy: an umbrella systematic review and comparative effectiveness network meta-analysis. *Ann Intern Med.* 2014;161(9):639–49.
- Gu Y, Dennis S. Are falls prevention programs effective at reducing the risk factors for falls in people with type-2 diabetes mellitus and peripheral neuropathy: a systematic review with narrative synthesis. *J Diabetes Complicat.* 2017;31(2):504–16.
- Gupta A, Silman J, Ray D, Morriss R, Dickens C, MacFarlane GJ, et al. The role of psychosocial factors in predicting the onset of chronic widespread pain: results from a prospective population-based study. *Rheumatology.* 2007;46:666–71.
- Gustafson D. Adiposity indices and dementia. *Lancet Neurol.* 2006;5(8):713–20.
- Haanpaa ML, Backonja MM, Bennett MI, Bouhassira D, Cruccu G, Hansson PT, et al. Assessment of neuropathic pain in primary care. *Am J Med.* 2009;122(10 Suppl):S13–21.
- Handelsman H, Bloomgarden ZT, Grunberger G, Umpierrez U, Zimmerman RS, Bailey TS, et al. American Association of Clinical Endocrinologists Clinical Practice Guidelines for developing a diabetes mellitus comprehensive care plan. *Endocr Pract.* 2015;21(4):413.
- Hanewinkel R, van Oijen M, Ikram MA, van Doorn PA. The epidemiology and risk factors of chronic polyneuropathy. *Eur J Epidemiol.* 2016;31(1):5–20.

- Hanlon JT, Boudreau RM, Roumani YF, Newman AB, Ruby CM, Wright RM, et al. Number and dosage of central nervous system medications on recurrent falls in community elders: the Health, Aging and Body Composition study. *J Gerontol A Biol Sci Med Sci*. 2009;64(4):492–8.
- Hanna M, O'Brien C, Wilson MC. Prolonged-release oxycodone enhances the effects of existing gabapentin therapy in painful diabetic neuropathy patients. *Eur J Pain*. 2008;12(6):804–13.
- Harati Y, Gooch C, Swenson M, Edelman S, Greene D, Raskin P, et al. Double-blind randomized trial of tramadol for the treatment of the pain of diabetic neuropathy. *Neurology*. 1998;50:1842–6.
- Harati Y, Gooch C, Swenson M, Edelman SV, Greene D, Raskin P, et al. Maintenance of the long-term effectiveness of Tramadol in treatment of the pain of diabetic neuropathy. *J Diabetes Complicat*. 2000;14:65–70.
- Hardy T, Sachson R, Shen S, Armbruster M, Boulton AJ. Does treatment with duloxetine for neuropathic pain impact glycemic control? *Diabetes Care*. 2007;30(1):21–6.
- Hausdorff JM, Yogev G, Springer S, Simon ES, Giladi N. Walking is more like catching than tapping: gait in the elderly as a complex cognitive task. *Exp Brain Res*. 2005;164(4):541–8.
- Havrankova J, Roth J, Brownstein M. Insulin receptors are widely distributed in the central nervous system of the rat. *Nature*. 1978;272(5656):827–9.
- Hearn L, Moore RA, Derry S, Wiffen PJ, Phillips T. Desipramine for neuropathic pain in adults. *Cochrane Database Syst Rev*. 2014;9:CD011003.
- Heath JM, Stuart MR. Prescribing exercise for frail elders. *J Am Board Fam Pract*. 2002;15(3):218–28.
- Herder C, Bongaerts BW, Rathmann W, Heier M, Kowall B, Koenig W, et al. Association of subclinical inflammation with polyneuropathy in the older population: KORA F4 study. *Diabetes Care*. 2013;36(11):3663–70.
- Herman WH, Kennedy L. Underdiagnosis of peripheral neuropathy in type 2 diabetes. *Diabetes Care*. 2005;28(6):1480–1.
- Herman WH, Pop-Busui R, Braffett BH, Martin CL, Cleary PA, Albers JW, et al. Use of the Michigan Neuropathy Screening Instrument as a measure of distal symmetrical peripheral neuropathy in type 1 diabetes: results from the Diabetes Control and Complications Trial/Epidemiology of Diabetes Interventions and Complications. *Diabet Med*. 2012;29(7):937–44.
- Herriott MT, Colberg SR, Parson HK, Nunnold T, Vinik AI. Effects of 8 weeks of flexibility and resistance training in older adults with type 2 diabetes. *Diabetes Care*. 2004;27(12):2988–9.
- Hertz P, Bril V, Orszag A, Ahmed A, Ng E, Nwe P, et al. Reproducibility of in vivo corneal confocal microscopy as a novel screening test for early diabetic sensorimotor polyneuropathy. *Diabet Med*. 2011;28(10):1253–60.
- Hill JM, Lesniak MA, Pert CB, Roth J. Autoradiographic localization of insulin receptors in rat brain: prominence in olfactory and limbic areas. *Neuroscience*. 1986;17:1127–38.
- Holzer SE, Camerota A, Martens L, Cuedon T, Crystal P, Zagari M. Costs and duration of care for lower extremity ulcers in patients with diabetes. *Clin Ther*. 1998;20:169–81.
- Howe TE, Rochester L, Neil F, Skelton DA, Ballinger C. Exercise for improving balance in older people. *Cochrane Database Syst Rev*. 2011;(11): CD004963. <https://doi.org/10.1002/14651858.CD004963.pub3>.
- Imms FJ, Edholm OG. Studies of gait and mobility in the elderly. *Age Ageing*. 1981;10(3):147–56.
- Ismail-Beigi F, Craven T, Banerji MA, Basile J, Calles J, Cohen RM, et al. Effect of intensive treatment of hyperglycaemia on microvascular outcomes in type 2 diabetes: an analysis of the ACCORD randomised trial. *Lancet*. 2010;376(9739):419–30.
- Jacobson AM, Musen G, Ryan CM, Silvers N, Cleary P, Waberski B, et al. Long-term effect of diabetes and its treatment on cognitive function. *N Engl J Med*. 2007;356(18):1842–52.
- Jensen MP, Chodroff MJ, Dworkin RH. The impact of neuropathic pain on health-related quality of life: review and implications. *Neurology*. 2007;68(15):1178–82.
- Jiang M-S. Corneal confocal microscopy for assessment of diabetic peripheral neuropathy: a meta-analysis. *Br J Ophthalmol*. 2016;100(1):9–14.
- Joseph JJ, Wang X, Spanakis E, Seeman T, Wand G, Needham B, et al. Diurnal salivary cortisol, glycemia and insulin resistance: the multi-ethnic study of atherosclerosis. *Psychoneuroendocrinology*. 2015;62:327–35.



- Joss JD. Tricyclic antidepressant use in diabetic neuropathy. *Ann Pharmacother.* 1999;33(9):996–1000.
- Kajdasz DK, Iyengar S, Desaiyah D, Backonja MM, Farrar JT, Fishbain DA, et al. Duloxetine for the management of diabetic peripheral neuropathic pain: evidence-based findings from post hoc analysis of three multicenter, randomized, double-blind, placebo-controlled, parallel-group studies. *Clin Ther.* 2007;29(Suppl):2536–46.
- Kalso E. Sodium channel blockers in neuropathic pain. *Curr Pharm Des.* 2005;11(23):3005–11.
- Karani R, McLaughlin MA, Cassel CK. Exercise in the healthy older adult. *Am J Geriatr Cardiol.* 2001;10(5):269–73.
- Katoulis EC, Ebdon-Parry M, Lanshammar H, Vileikyte L, Kulkarni J, Boulton AJ. Gait abnormalities in diabetic neuropathy. *Diabetes Care.* 1997;20(12):1904–7.
- Kessler JA, Smith AG, Cha BS, Choi SH, Wymer J, Shaibani A, et al. Double-blind, placebo-controlled study of HGF gene therapy in diabetic neuropathy. *Ann Clin Transl Neurol.* 2015;2(5):465–78.
- Kikta DG, Breuer AC, Wilbourn AJ. Thoracic root pain in diabetes: the spectrum of clinical and electromyographic findings. *Ann Neurol.* 1982;11:80–5.
- Kirkman S, Briscoe V, Clark N, et al. Diabetes in older adults: a consensus report. *J Am Geriatr Soc.* 2012;60:2342.
- Klein BE, Klein R, Knudtson MD, Lee KE, Danforth LG, Reinke JO, et al. Associations of selected medications and visual function: the Beaver Dam Eye Study. *Br J Ophthalmol.* 2003;87(4):403–8.
- Kloppenborg RP, van den Berg E, Kappelle LJ, Biessels GJ. Diabetes and other vascular risk factors for dementia: which factor matters most? A systematic review. *Eur J Pharmacol.* 2008;585(1):97–108.
- Kluding PM, Pasnoor M, Singh R, Jernigan S, Farmer K, Rucker J, et al. The effect of exercise on neuropathic symptoms, nerve function, and cutaneous innervation in people with diabetic peripheral neuropathy. *J Diabetes Complicat.* 2012;26(5):424–9.
- Knowler WC, Barrett-Connor E, Fowler SE, Hamman RF, Lachin JM, Walker EA, et al. Reduction in the incidence of type 2 diabetes with lifestyle intervention or metformin. *N Engl J Med.* 2002;346(6):393–403.
- Krause S, Backonja M. Development of a neuropathic pain questionnaire. *Clin J Pain.* 2003;19:306–14.
- Krein SL, Heisler M, Piette JD, Makki F, Kerr EA. The effect of chronic pain on diabetes patients' self-management. *Diabetes Care.* 2005;28(1):65–70.
- Krendel DA, Costigan DA, Hopkins LC. Successful treatment of neuropathies in patients with diabetes mellitus. *Arch Neurol.* 1995;52:1053–61.
- Krendel DA, Zacharias A, Younger DS. Autoimmune diabetic neuropathy. *Neurol Clin.* 1997;15:959–71.
- Kumar D. Diabetic peripheral neuropathy: effectiveness of electrotherapy and amitriptyline for symptomatic relief. *Diabetes Care.* 1998;21:1322–5.
- Lafond D, Corriveau H, Prince F. Postural control mechanisms during quiet standing in patients with diabetic sensory neuropathy. *Diabetes Care.* 2004;27(1):173–8.
- Lalli P, Chan A, Garven A, Midha N, Chan C, Brady S, et al. Increased gait variability in diabetes mellitus patients with neuropathic pain. *J Diabetes Complicat.* 2013;27(3):248–54.
- Lampert DJ, Lawton CL, Mansfield MW, Dye L. Impairments in glucose tolerance can have a negative impact on cognitive function: a systematic research review. *Neurosci Biobehav Rev.* 2009;33(3):394–413.
- Landefeld CS, Steinman MA. The Neurontin legacy – marketing through misinformation and manipulation. *N Engl J Med.* 2009;360(2):103–6.
- Laughlin RS, Dyck PJ. Electrodiagnostic testing in lumbosacral plexopathies. *Phys Med Rehabil Clin N Am.* 2013;24(1):93–105.
- Lauria G, Lombardi R. Skin biopsy: a new tool for diagnosing peripheral neuropathy. *BMJ.* 2007;334(7604):1159–62.
- Lauria G, Hsieh S, Johansson O, Kennedy W, Leger J, Mellgren S, et al. European Federation of Neurological Societies/Peripheral Nerve Society guideline on the use of skin biopsy in the

- diagnosis of small fiber neuropathy. Report of a joint task force of the European Federation of Neurological Societies and the Peripheral Nerve Society. *Eur J Neurol*. 2010a;17:903–12.
- Lauria G, Bakkers M, Schmitz C, Lombardi R, Penza P, Devigili G, et al. Intraepidermal nerve fiber density at the distal leg: a worldwide normative reference study. *J Peripher Nerv Syst*. 2010b; 15(3):202–7.
- Lesser H, Sharma U, LaMoreaux L, Poole RM. Pregabalin relieves symptoms of painful diabetic neuropathy: a randomized controlled trial. *Neurology*. 2004;63(11):2104–10.
- Lezak MD. *Neuropsychological assessment*. 4th ed. New York: Oxford University Press; 2004.
- Ligthelm RJ, Kaiser M, Vora J, Yale JF. Insulin use in elderly adults: risk of hypoglycemia and strategies for care. *J Am Geriatr Soc*. 2012;60(8):1564–70.
- Lindsay J, Hebert R, Rockwood K. The Canadian Study of Health and Aging: risk factors for vascular dementia. *Stroke*. 1997;28(3):526–30.
- Lloyd BD, Williamson DA, Singh NA, Hansen RD, Diamond TH, Finnegan TP, et al. Recurrent and injurious falls in the year following hip fracture: a prospective study of incidence and risk factors from the Sarcopenia and Hip Fracture study. *J Gerontol A Biol Sci Med Sci*. 2009; 64(5):599–609.
- Loeser JD, Treede RD. The Kyoto protocol of IASP basic pain terminology. *Pain*. 2008;137:473–7.
- Lonn EM, Rambihar S, Gao P, Custodis FF, Sliwa K, Teo KK, et al. Heart rate is associated with increased risk of major cardiovascular events, cardiovascular and all-cause death in patients with stable chronic cardiovascular disease: an analysis of ONTARGET/TRANSCEND. *Clin Res Cardiol*. 2014;103(2):149–59.
- Low PA. Diabetic autonomic neuropathy. *Semin Neurol*. 1996;16(2):143–51.
- Low PA, Benrud-Larson LM, Sletten DM, Opfer-Gehrking TL, Weigand SD, O'Brien PC, et al. Autonomic symptoms and diabetic neuropathy: a population-based study. *Diabetes Care*. 2004;27(12):2942–7.
- Luchsinger JA, Tang MX, Stern Y, Shea S, Mayeux R. Diabetes mellitus and risk of Alzheimer's disease and dementia with stroke in a multiethnic cohort. *Am J Epidemiol*. 2001;154(7):635–41.
- Luchsinger JA, Tang MX, Shea S, Mayeux R. Hyperinsulinemia and risk of Alzheimer disease. *Neurology*. 2004;63(7):1187–92.
- Lykke JA, Tarnow L, Parving HH, Hilsted JA. combined abnormality in heart rate variation and QT corrected interval is a strong predictor of cardiovascular death in type 1 diabetes. *Scand J Clin Lab Invest*. 2008;68(7):654–9.
- Lysy Z, Lovblom LE, Halpern EM, Ngo M, Ng E, Orszag A, et al. Measurement of cooling detection thresholds for identification of diabetic sensorimotor polyneuropathy in type 1 diabetes. *PLoS One*. 2014;9(9):e106995.
- Maki BE. Gait changes in older adults: predictors of falls or indicators of fear. *J Am Geriatr Soc*. 1997;45(3):313–20.
- Malik RA, Veves A, Tesfaye S, Smith G, Cameron N, Zochodne D, et al. Small fibre neuropathy: role in the diagnosis of diabetic sensorimotor polyneuropathy. *Diabetes Metab Res Rev*. 2011; 27(7):678–84.
- Mantyselka P, Ahonen R, Kumpusalo E, Takala J. Variability in prescribing for musculoskeletal pain in Finnish primary health care. *Pharm World Sci*. 2001;23(6):232–6.
- Maraldi C, Volpato S, Penninx BW, Yaffe K, Simonsick EM, Strotmeyer ES, et al. Diabetes mellitus, glycemic control, and incident depressive symptoms among 70- to 79-year-old persons: the health, aging, and body composition study. *Arch Intern Med*. 2007;167(11):1137–44.
- Martin CL, Albers J, Herman WH, Cleary P, Waberski B, Greene DA, et al. Neuropathy among the diabetes control and complications trial cohort 8 years after trial completion. *Diabetes Care*. 2006;29(2):340–4.
- Martin CL, Albers JW, Pop-Busui R. Neuropathy and related findings in the diabetes control and complications trial/epidemiology of diabetes interventions and complications study. *Diabetes Care*. 2014;37(1):31–8.
- Maser RE, Steenkiste AR, Dorman JS, Nielsen VK, Bass EB, Manjoo Q, et al. Epidemiological correlates of diabetic neuropathy report from Pittsburgh Epidemiology of Diabetes Complications Study. *Diabetes*. 1989;38:1456–61.

- Maser RE, Mitchell BD, Vinik AI, Freeman R. The association between cardiovascular autonomic neuropathy and mortality in individuals with diabetes: a meta-analysis. *Diabetes Care*. 2003; 26(6):1895–901.
- Mason L, Moore RA, Derry S, Edwards JE, McQuay HJ. Systematic review of topical capsaicin for the treatment of chronic pain. *BMJ*. 2004;328(7446):991.
- Mathews VP, Barker PB, Blackband SJ, Chatham JC, Bryan RN. Cerebral metabolites in patients with acute and subacute strokes: concentrations determined by quantitative proton MR spectroscopy. *AJR Am J Roentgenol*. 1995;165(3):633–8.
- Maurer MS, Burcham J, Cheng H. Diabetes mellitus is associated with an increased risk of falls in elderly residents of a long-term care facility. *J Gerontol A Biol Sci Med Sci*. 2005; 60(9): 1157–62.
- Max MB, Culnane M, Schafer SC, Gracely RH, Walther DJ, Smoller B, et al. Amitriptyline relieves diabetic neuropathy pain in patients with normal or depressed mood. *Neurology*. 1987; 37(4):589–96.
- Max MB, Kishore-Kumar R, Schafer SC, Meister B, Gracely RH, Smoller B, et al. Efficacy of desipramine in painful diabetic neuropathy: a placebo-controlled trial. *Pain*. 1991;45(1):3–9.
- Max M, Lynch S, Muir J. Effects of desipramine, amitriptyline and fluoxetine on pain in diabetic neuropathy. *N Engl J Med*. 1992;326:1250–6.
- Mayaudon H, Miloche PO, Bauduceau BA. new simple method for assessing sudomotor function: relevance in type 2 diabetes. *Diabete Metab*. 2010;36(6 Pt 1):450–4.
- McEvoy LK, Laughlin GA, Barrett-Connor E, Bergstrom J, Kritiz-Silverstein D, Der-Martirosian C, et al. Metabolic syndrome and 16-year cognitive decline in community-dwelling older adults. *Ann Epidemiol*. 2012;22(5):310–7.
- McGuire LC, Ford ES, Ajani UA. The impact of cognitive functioning on mortality and the development of functional disability in older adults with diabetes: the second longitudinal study on aging. *BMC Geriatr*. 2006;6:8.
- McNay EC, Cotero VE. Mini-review: impact of recurrent hypoglycemia on cognitive and brain function. *Physiol Behav*. 2010;100(3):234–8.
- Menz HB, Lord SR, Fitzpatrick RC. A structural equation model relating impaired sensorimotor function, fear of falling and gait patterns in older people. *Gait Posture*. 2007;25(2):243–9.
- Molnar G, Farago N, Kocsis AK, Rozsa M, Lovas S, Boldog E, et al. GABAergic neurogliaform cells represent local sources of insulin in the cerebral cortex. *J Neurosci*. 2014;34(4):1133–7.
- Moloney NA, Hall TM, Doody CM. Reliability of thermal quantitative sensory testing: a systematic review. *J Rehabil Res Dev*. 2012;49(2):191–207.
- Mooradian AD. Diabetic complications of the central nervous system. *Endocr Rev*. 1988; 9(3): 346–56.
- Mooradian AD, Perryman K, Fitten J, Kavonian GD, Morley JE. Cortical function in elderly non-insulin dependent diabetic patients. Behavioral and electrophysiologic studies. *Arch Intern Med*. 1988;148(11):2369–72.
- Moreira BS, Dos Anjos DM, Pereira DS, Sampaio RF, Pereira LS, Dias RC, et al. The geriatric depression scale and the timed up and go test predict fear of falling in community-dwelling elderly women with type 2 diabetes mellitus: a cross-sectional study. *BMC Geriatr*. 2016;16:56.
- Morello CM, Leckband SG, Stoner CP, Moorhouse DF, Sahagian GA. Randomized double-blind study comparing the efficacy of gabapentin with amitriptyline on diabetic peripheral neuropathy pain. *Arch Intern Med*. 1999;159(16):1931–7.
- Morrison S, Colberg SR, Mariano M, Parson HK, Vinik AI. Balance training reduces falls risk in older individuals with type 2 diabetes. *Diabetes Care*. 2010;33(4):748–50.
- Morrison S, Colberg SR, Parson HK, Vinik AI. Relation between risk of falling and postural sway complexity in diabetes. *Gait Posture*. 2012;35(4):662–8.
- Moxey PW, Gogalniceanu P, Hinchliffe RJ, Loftus IM, Jones KJ, Thompson MM, et al. Lower extremity amputations – a review of global variability in incidence. *Diabet Med*. 2011; 28(10):1144–53.
- Munshi M, Grande L, Hayes M, Ayres D, Suhl E, Capelson R, et al. Cognitive dysfunction is associated with poor diabetes control in older adults. *Diabetes Care*. 2006;29(8):1794–9.

- O'Connor AB. Neuropathic pain: quality-of-life impact, costs and cost effectiveness of therapy. *Pharmacoeconomics*. 2009;27(2):95–112.
- O'Brien PD, Hinder LM, Sakowski SA, Feldman ELER. stress in diabetic peripheral neuropathy: a new therapeutic target. *Antioxid Redox Signal*. 2014;21(4):621–33.
- Obrosova I, Shevalye H. Metax alleviates diabetes-induced large and small fiber neuropathies and promotes small sensory nerve fiber regeneration. *Diabetes*. 2011;60:652–P
- Ostrovski I, Lovblom LE, Farooqi MA, Scarr D, Boulet G, Hertz P, et al. Reproducibility of in vivo corneal confocal microscopy using an automated analysis program for detection of diabetic sensorimotor polyneuropathy. *PLoS One*. 2015;10(11):e0142309.
- Ott A, Stolk RP, Hofman A, van Harskamp F, Grobbee DE, Breteler MM. Association of diabetes mellitus and dementia: the Rotterdam Study. *Diabetologia*. 1996;39(11):1392–7.
- Panel on Prevention of Falls in Older Persons AGS, British Geriatrics Society. Summary of the Updated American Geriatrics Society/British Geriatrics Society clinical practice guideline for prevention of falls in older persons. *J Am Geriatr Soc*. 2011;59(1):148–57.
- Parekh PJ, Nayi VR, Johnson DA, Vinik AI. The role of gut microflora and the cholinergic anti-inflammatory neuroendocrine system in diabetes mellitus. *Front Endocrinol (Lausanne)*. 2016;7:55.
- Park CR. Cognitive effects of insulin in the central nervous system. *Neurosci Biobehav Rev*. 2001;25(4):311–23.
- Partanen J, Niskanen L, Lehtinen J, Mervaala E, Siitonen O, Uusitupa M. Natural history of peripheral neuropathy in patients with non-insulin-dependent diabetes mellitus. *N Engl J Med*. 1995;333:89–94.
- Perkins ND. The Rel/NF-kappa B family: friend and foe. *Trends Biochem Sci*. 2000;25(9):434–40.
- Perkins BA, Olaleye D, Zinman B, Bril V. Simple screening tests for peripheral neuropathy in the diabetes clinic. *Diabetes Care*. 2001;24(2):250–6.
- Perkins B, Olaleye D, Bril V. Carpal tunnel syndrome in patients with diabetic polyneuropathy. *Diabetes Care*. 2002;25:565–9.
- Perlmutter LC, Tun P, Sizer N, McGlinchey RE, Nathan DM. Age and diabetes related changes in verbal fluency. *Exp Aging Res*. 1987;13(1–2):9–14.
- Peron EP, Ogbonna KC. Diabetic medications and polypharmacy. *Clin Geriatr Med*. 2015;31(1):17–27.
- Peterson MJ, Giuliani C, Morey MC, Pieper CF, Evenson KR, Mercer V, et al. Physical activity as a preventative factor for frailty: the health, aging, and body composition study. *J Gerontol A Biol Sci Med Sci*. 2009;64(1):61–8.
- Petropoulos IN, Manzoor T, Morgan P, Fadavi H, Asghar O, Alam U, et al. Repeatability of in vivo corneal confocal microscopy to quantify corneal nerve morphology. *Cornea*. 2013a;32(5):e83–9.
- Petropoulos IN, Alam U, Fadavi H, Asghar O, Green P, Ponirakis G, et al. Corneal nerve loss detected with corneal confocal microscopy is symmetrical and related to the severity of diabetic polyneuropathy. *Diabetes Care*. 2013b;36(11):3646–51.
- Piovesan EJ, Teive HG, Kowacs PA, la Coletta MV, Werneck LC, Silberstein SD. An open study of botulinum-A toxin treatment of trigeminal neuralgia. *Neurology*. 2005;65(8):1306–8.
- Pittenger G, Vinik A. Nerve growth factor and diabetic neuropathy. *Exp Diabetes Res*. 2003;4(4):271–85.
- Pittenger GL, Ray M, Burcus NI, McNulty P, Basta B, Vinik AI. Intraepidermal nerve fibers are indicators of small-fiber neuropathy in both diabetic and nondiabetic patients. *Diabetes Care*. 2004;27(8):1974–9.
- Pittenger G, Mehrabyan A, Simmons K, Rice A, Dublin C, Barlow P, et al. Small fiber neuropathy is associated with the metabolic syndrome. *Metab Syndr Relat Disord*. 2005a;3(2):113–21.
- Pittenger G, Simmons K, Anandacoomaraswamy D, Rice A, Barlow P, Vinik A. Topiramate improves intraepidermal nerve fiber morphology and quantitative neuropathy measures in diabetic neuropathy patients. *J Peripher Nerv Syst*. 2005b;10(Suppl 1):73.
- Polydefkis M, Hauer P, Griffin JW, McArthur JC. Skin biopsy as a tool to assess distal small fiber innervation in diabetic neuropathy. *Diabetes Technol Ther*. 2001;3(1):23–8.

- Pop-Busui R. Cardiac autonomic neuropathy in diabetes: a clinical perspective. *Diabetes Care*. 2010;33(2):434–41.
- Pop-Busui R, Low PA, Waberski BH, Martin CL, Albers JW, Feldman EL, et al. Effects of prior intensive insulin therapy on cardiac autonomic nervous system function in type 1 diabetes mellitus: the Diabetes Control and Complications Trial/Epidemiology of Diabetes Interventions and Complications study (DCCT/EDIC). *Circulation*. 2009;119(22):2886–93.
- Pop-Busui R, Evans G, Gerstein H, Fonseca V, Fleg J, Hoogwerf B, et al. Effects of cardiac autonomic dysfunction on mortality risk in the action to control cardiovascular risk in diabetes (ACCORD) trial. *Diabetes Care*. 2010;33(7):1578–84.
- Pop-Busui R, Lu J, Brooks MM, Albert S, Althouse AD, Escobedo J, et al. Impact of glycemic control strategies on the progression of diabetic peripheral neuropathy in the Bypass Angioplasty Revascularization Investigation 2 Diabetes (BARI 2D) cohort. *Diabetes Care*. 2013a;36(10):3208–15.
- Pop-Busui R, Cleary PA, Braffett BH, Martin CL, Herman WH, Low PA, et al. Association between cardiovascular autonomic neuropathy and left ventricular dysfunction: DCCT/EDIC study (Diabetes Control and Complications Trial/Epidemiology of Diabetes Interventions and Complications). *J Am Coll Cardiol*. 2013b;61(4):447–54.
- Pop-Busui R, Boulton AJ, Feldman EL, Bril V, Freeman R, Malik RA, et al. Diabetic neuropathy: a position statement by the American Diabetes Association. *Diabetes Care*. 2017;40(1):136–54.
- Portenoy R. Development and testing of a neuropathic pain screening questionnaire: ID pain. *Curr Med Res Opin*. 2006;22(8):1555–65.
- Punthakee Z, Miller ME, Launer LJ, Williamson JD, Lazar RM, Cukierman-Yaffee T, et al. Poor cognitive function and risk of severe hypoglycemia in type 2 diabetes: post hoc epidemiologic analysis of the ACCORD trial. *Diabetes Care*. 2012;35(4):787–93.
- Quilici S, Chancellor J, Lothgren M, Simon D, Said G, Le TK, et al. Meta-analysis of duloxetine vs. pregabalin and gabapentin in the treatment of diabetic peripheral neuropathic pain. *BMC Neurol*. 2009;9:6–19.
- Rains C, Bryson HM. Topical capsaicin. A review of its pharmacological properties and therapeutic potential in post-herpetic neuralgia, diabetic neuropathy and osteoarthritis. *Drugs Aging*. 1995;7:317–28.
- Raisanen A, Eklund J, Calvet J-H, Tuomilehto J. Sudomotor function as a tool for cardiorespiratory fitness level evaluation: comparison with VO<sub>2</sub> max. *Int J Environ Res Public Health*. 2014;11:5839–48. <https://doi.org/10.3390/ijerph10x000x>.
- Raskin P, Donofrio PD, Rosenthal NR, Hewitt DJ, Jordan DM, Xiang J, et al. Topiramate vs placebo in painful diabetic neuropathy: analgesic and metabolic effects. *Neurology*. 2004;63(5):865–73.
- Ray WA, Meredith S, Thapa PB, Hall K, Murray KT. Cyclic antidepressants and the risk of sudden cardiac death. *Clin Pharmacol Ther*. 2004;75:234–41.
- Reaven GM, Thompson LW, Nahum D, Haskins E. Relationship between hyperglycemia and cognitive function in older NIDDM patients. *Diabetes Care*. 1990;13(1):16–21.
- Reichard P, Pihl M, Rosenqvist U, Sule J. Complications in IDDM are caused by elevated blood glucose level: the Stockholm Diabetes Intervention Study (SDIS) at 10-year follow up. *Diabetologia*. 1996;39(12):1483–8.
- Reljanovic M, Reichel G, Rett K, Lobisch M, Schuette K, Moller W, et al. Treatment of diabetic polyneuropathy with the antioxidant thioctic acid (alpha-lipoic acid): a two year multicenter randomized double-blind placebo-controlled trial (ALADIN II). *Alpha lipoic acid in diabetic neuropathy*. *Free Radic Res*. 1999;31(3):171–9.
- Renard C, Chappay O, Wautier MP, Nagashima M, Lundh E, Morser J, et al. Recombinant advanced glycation end product receptor pharmacokinetics in normal and diabetic rats. *Mol Pharmacol*. 1997;52(1):54–62.
- Renneboog B, Musch W, Vandemergel X, Manto MU, Decaux G. Mild chronic hyponatremia is associated with falls, unsteadiness, and attention deficits. *Am J Med*. 2006;119(1):71–8.
- Resnick B. Functional performance of older adults in a long-term care setting. *Clin Nurs Res*. 1998;7(3):230–46.

- Resnick H, Vinik A, Schwartz A, Leveille S, Brancati F, Balfour J, et al. Independent effects of peripheral nerve dysfunction on lower-extremity physical function in old age. *Diabetes Care*. 2000;23(11):1642–7.
- Resnick HE, Stansberry KB, Harris TB, Tirivedi M, Smith K, Morgan P, et al. Diabetes, peripheral neuropathy, and old age disability. *Muscle Nerve*. 2002;25(1):43–50.
- Richardson JK, Hurvitz EA. Peripheral neuropathy: a true risk factor for falls. *J Gerontol A Biol Sci Med Sci*. 1995;50(4):M211–5.
- Richardson JK, Thies SB, DeMott TK, Ashton-Miller JA. Gait analysis in a challenging environment differentiates between fallers and nonfallers among older patients with peripheral neuropathy. *Arch Phys Med Rehabil*. 2005;86(8):1539–44.
- Richardson J, Thies S, Ashton-Miller J. An exploration of step time variability on smooth and irregular surfaces in older persons with neuropathy. *Clin Biomech*. 2008;23:349–56.
- Richter RW, Portenoy R, Sharma U, LaMoreaux L, Bockbrader H, Knapp LE. Relief of painful diabetic peripheral neuropathy with pregabalin: a randomized, placebo-controlled trial. *J Pain*. 2005;6(4):253–60.
- Rivard A, Silver M, Chen D, Kearney M, Magner M, Annex B, et al. Rescue of diabetes-related impairment of angiogenesis by intramuscular gene therapy with adeno-VEGF. *Am J Pathol*. 1999;154(2):355–63.
- Robinovitch SN, Hsiao ET, Sandler R, Cortez J, Liu Q, Paiement GD. Prevention of falls and fall-related fractures through biomechanics. *Exerc Sport Sci Rev*. 2000;28(2):74–9.
- Rolke R, Baron R, Maier C, Tolle TR, Treede RD, Beyer A, et al. Quantitative sensory testing in the German research network on neuropathic pain (DFNS): standardized protocol and reference values. *Pain*. 2006;123(3):231–43.
- Roriz-Filho J, Sa-Roriz T, Rosset I, Camozzato A, Santos A, et al. (Pre)diabetes, brain aging, and cognition. *Biochim Biophys Acta*. 2009;1792(5):432–43.
- Rosenstock J, Tuchman M, LaMoreaux L, Sharma U. Pregabalin for the treatment of painful diabetic peripheral neuropathy: a double-blind, placebo-controlled trial. *Pain*. 2004;110(3):628–38.
- Rowbotham MC, Goli V, Kunz NR, Lei D. Venlafaxine extended release in the treatment of painful diabetic neuropathy: a double-blind, placebo-controlled study. *Pain*. 2004;110(3):697–706.
- Ruhnau KJ, Meissner HP, Finn R, Reljanovic M, Lobisch M, Schutte K, et al. Effects of 3-week oral treatment with the antioxidant thioctic acid (alpha-lipoic acid) in symptomatic diabetic polyneuropathy. *Diabet Med*. 1999;16(12):1040–3.
- Ryan CM, Freed MI, Rood JA, Cobitz AR, Waterhouse BR, Strachan MW. Improving metabolic control leads to better working memory in adults with type 2 diabetes. *Diabetes Care*. 2006;29(2):345–51.
- Sabatowski R, Galvez R, Cherry DA, Jacquot F, Vincent E, Maisonobe P, et al. Pregabalin reduces pain and improves sleep and mood disturbances in patients with post-herpetic neuralgia: results of a randomised, placebo-controlled clinical trial. *Pain*. 2004;109(1-2):26–35.
- Sabri O, Ringelstein EB, Hellwig D, Schneider R, Schreckenberger M, Kaiser HJ, et al. Neuropsychological impairment correlates with hypoperfusion and hypometabolism but not with severity of white matter lesions on MRI in patients with cerebral microangiopathy. *Stroke*. 1999;30(3):556–66.
- Said G, Goulon-Goreau C, Lacroix C, Moulouguet A. Nerve biopsy findings in different patterns of proximal diabetic neuropathy. *Ann Neurol*. 1994;35(5):559–69.
- Samaras K, Sachdev PS. Diabetes and the elderly brain: sweet memories? *Adv Endocrinol Metab*. 2012;3(6):189–96.
- Sander HW, Chokroverty S. Diabetic amyotrophy: current concepts. *Semin Neurol*. 1996;16:173–8.
- Sandhu HS, Gilles E, DeVita MV, Panagopoulos G, Michelis MF. Hyponatremia associated with large-bone fracture in elderly patients. *Int Urol Nephrol*. 2009;41(3):733–7.
- Sansone RA, Sansone LA. Pain, pain, go away: antidepressants and pain management. *Psychiatry (Edgmont)*. 2008;5(12):16–9.
- Sato N, Morishita R. Brain alterations and clinical symptoms of dementia in diabetes: abeta/tau-dependent and independent mechanisms. *Front Endocrinol (Lausanne)*. 2014;5:143.

- Scholz J, Mannion RJ, Hord DE, Griffin RS, Rawal B, Zheng H, et al. A novel tool for the assessment of pain: validation in low back pain. *PLoS Med.* 2009;6(4):e1000047.
- Schwartz AV, Vittinghoff E, Sellmeyer DE, Feingold KR, de Rekeneire N, Strotmeyer ES, et al. Diabetes-related complications, glycemic control, and falls in older adults. *Diabetes Care.* 2008;31(3):391–6.
- Schwartz S, Etropolski M, Shapiro DY, Okamoto A, Lange R, Haeussler J, et al. Safety and efficacy of tapentadol ER in patients with painful diabetic peripheral neuropathy: results of a randomized-withdrawal, placebo-controlled trial. *Curr Med Res Opin.* 2011;27(1):151–62.
- Selvarajah D, Wilkinson ID, Griffiths PD, Shaw PJ, Emery CJ, Tesfaye S. Abnormal Thalamic magnetic resonance spectroscopy: evidence for functional impairment of the thalamus in diabetic neuropathy. *Diabet Med.* 2004;21(Suppl 2):2–3.
- Selvarajah D, Wilkinson ID, Emery CJ, Harris ND, Shaw PJ, Witte DR, et al. Early involvement of the spinal cord in diabetic peripheral neuropathy. *Diabetes Care.* 2006;29(12):2664–9.
- Selvarajah D, Cash T, Davies J, Sankar A, Rao G, Grieg M, et al. SUDOSCAN: a simple, rapid, and objective method with potential for screening for diabetic peripheral neuropathy. *PLoS One.* 2015;10(10):e0138224.
- Sharma K, Cross J, Farronay O, Ayyar D, Sheber R, Bradley W. Demyelinating neuropathy in diabetes mellitus. *Arch Neurol.* 2002;59:758–65.
- Shemesh E, Rudich A, Harman-Boehm I, Cukierman-Yaffe T. Effect of intranasal insulin on cognitive function: a systematic review. *J Clin Endocrinol Metab.* 2012;97(2):366–76.
- Sherrington C, Lord SR, Herbert RD. A randomised trial of weight-bearing versus non-weight-bearing exercise for improving physical ability in inpatients after hip fracture. *Aust J Physiother.* 2003;49(1):15–22.
- Simoneau GG, Ulbrecht J, Derr JA, Becher MB, Cavanaugh PR. Postural instability in patients with diabetic sensory neuropathy. *Diabetes Care.* 1994;17:1411–21.
- Simpson DA. Gabapentin and venlafaxine for the treatment of painful diabetic neuropathy. *J Clin Neuromuscul Dis.* 2001;3(2):53–62.
- Sindrup SH, Jensen TS. Pharmacologic treatment of pain in polyneuropathy. *Neurology.* 2000;55(7):915–20.
- Singleton JR, Smith AG, Bromberg MB. Increased prevalence of impaired glucose tolerance in patients with painful sensory neuropathy. *Diabetes Care.* 2001;24(8):1448–53.
- Singleton JR, Bixby B, Russell JW, Feldman EL, Peltier A, Goldstein J, et al. The Utah Early Neuropathy Scale: a sensitive clinical scale for early sensory predominant neuropathy. *J Peripher Nerv Syst.* 2008;13(3):218–27.
- Singleton JR, Marcus RL, Jackson JE, Lessard K, Graham TE, Smith AG. Exercise increases cutaneous nerve density in diabetic patients without neuropathy. *Ann Clin Transl Neurol.* 2014;1(10):844–9.
- Sinnreich M, Taylor BV, Dyck PJ. Diabetic neuropathies. Classification, clinical features, and pathophysiological basis. *Neurologist.* 2005;11(2):63–79.
- Sivaskandarajah GA, Halpern EM, Lovblom LE, Weisman A, Orlov S, Bril V, et al. Structure-function relationship between corneal nerves and conventional small-fiber tests in type 1 diabetes. *Diabetes Care.* 2013;36(9):2748–55.
- Slangen R, Schaper NC, Faber CG, Joosten EA, Dirksen CD, van Dongen RT, et al. Spinal cord stimulation and pain relief in painful diabetic peripheral neuropathy: a prospective two-center randomized controlled trial. *Diabetes Care.* 2014;37(11):3016–24.
- Smith BE. Focal and entrapment neuropathies. *Handb Clin Neurol.* 2014;126:31–43.
- Smith AG, Singleton JR. Diabetic neuropathy. *Continuum (Minneapolis Minn).* 2012;18(1):60–84.
- Smith AG, Howard JR, Kroll R, Ramachandran P, Hauer P, et al. The reliability of skin biopsy with measurement of intraepidermal nerve fiber density. *J Neurol Sci.* 2005;228(1):65–9.
- Smith AG, Russell J, Feldman EL, Goldstein J, Peltier A, Smith S, et al. Lifestyle intervention for pre-diabetic neuropathy. *Diabetes Care.* 2006;29(6):1294–9.
- Soedamah-Muthu SS, Chaturvedi N, Witte DR, Stevens LK, Porta M, Fuller JH. Relationship between risk factors and mortality in type 1 diabetic patients in Europe: the EURODIAB Prospective Complications Study (PCS). *Diabetes Care.* 2008;31(7):1360–6.

- Spallone V. La neuropatia diabetica dolorosa: approccio alla diagnosi e alla terapia di un problema emergente. *Medea*. 2009;9:1–14.
- Spallone V, Ziegler D, Freeman R, Bernardi L, Frontoni S, Pop-Busui R, et al. Cardiovascular autonomic neuropathy in diabetes: clinical impact, assessment, diagnosis, and management. *Diabetes Metab Res Rev*. 2011a;27:639.
- Spallone V, Bellavere F, Scionti L, Maule S, Quadri R, Bax G, et al. Recommendations for the use of cardiovascular tests in diagnosing diabetic autonomic neuropathy. *Nutr Metab Cardiovasc Dis*. 2011b;21(1):69–78.
- Stem MS, Hussain M, Lentz SI, Raval N, Gardner TW, Pop-Busui R, et al. Differential reduction in corneal nerve fiber length in patients with type 1 or type 2 diabetes mellitus. *J Diabetes Complicat*. 2014;28(5):658–61.
- Steptoe A, Hackett RA, Lazzarino AI, Bostock S, La MR, Carvalho LA, et al. Disruption of multisystem responses to stress in type 2 diabetes: investigating the dynamics of allostatic load. *Proc Natl Acad Sci U S A*. 2014;111(44):15693–8.
- Stewart R, Liolitsa D. Type 2 diabetes mellitus, cognitive impairment and dementia. *Diabet Med*. 1999;16(2):93–112.
- Strachan MW. R D Lawrence Lecture 2010. The brain as a target organ in type 2 diabetes: exploring the links with cognitive impairment and dementia. *Diabet Med*. 2011;28(2):141–7.
- Strachan MW, Price JF. Diabetes. Cognitive decline and T2DM – a disconnect in the evidence? *Nat Rev Endocrinol*. 2014;10(5):258–60.
- Stranahan AM, Arumugam TV, Cutler RG, Lee K, Egan JM, Mattson MP. Diabetes impairs hippocampal function through glucocorticoid-mediated effects on new and mature neurons. *Nat Neurosci*. 2008;11(3):309–17.
- Strotmeyer ES, de Rekeneire N, Schwartz AV, Faulkner KA, Resnick HE, Goodpaster BH, et al. The relationship of reduced peripheral nerve function and diabetes with physical performance in older white and black adults: the Health, Aging, and Body Composition (Health ABC) study. *Diabetes Care*. 2008;31(9):1767–72.
- Strotmeyer ES, de Rekeneire N, Schwartz AV, Resnick HE, Goodpaster BH, Faulkner KA, et al. Sensory and motor peripheral nerve function and lower-extremity quadriceps strength: the health, aging and body composition study. *J Am Geriatr Soc*. 2009;57(11):2004–10.
- Takeda A, Wakai M, Niwa H, Dei R, Yamamoto M, Li M, et al. Neuronal and glial advanced glycation end product [Nepsilon-(carboxymethyl)lysine] in Alzheimer's disease brains. *Acta Neuropathol*. 2001;101(1):27–35.
- Tam J, Rosenberg L, Maysinger D. INGAP peptide improves nerve function and enhances regeneration in streptozotocin-induced diabetic C57BL/6 mice. *FASEB J*. 2004;18(14):1767–9.
- Task Force of the European Society of Cardiology and the North American Society of Pacing and Electrophysiology. Heart rate variability: standards of measurement, physiological interpretation and clinical use. *Circulation*. 1996;93:1043–65.
- Tavakoli M, Malik RA. Corneal confocal microscopy: a novel non-invasive technique to quantify small fibre pathology in peripheral neuropathies. *J Vis Exp*. 2011;47:2194.
- Tavakoli M, Quattrini C, Abbott C, Kallinikos P, Marshall A, Finnigan J, et al. Corneal confocal microscopy: a novel noninvasive test to diagnose and stratify the severity of human diabetic neuropathy. *Diabetes Care*. 2010;33(8):1792–7.
- Tesfaye S. Painful diabetic neuropathy. Aetiology and nonpharmacological treatment. In: Veves A, editor. *Clinical management of diabetic neuropathy*. Totowa: Humana Press; 1998. p. 369–86.
- Tesfaye S, Stevens LK, Stephenson JM, Fuller JH, Plater M, Ionescu-Tirgoviste C, et al. Prevalence of diabetic peripheral neuropathy and its relation to glycaemic control and potential risk factors: the EURODIAB IDDM Complications Study. *Diabetologia*. 1996a;39(11):1377–84.
- Tesfaye S, Watt J, Benbow SJ, Pang KA, Miles J, MacFarlane IA. Electrical spinal-cord stimulation for painful diabetic peripheral neuropathy. *Lancet*. 1996b;348:1698–701.
- Tesfaye S, Boulton AJ, Dyck PJ, Freeman R, Horowitz M, Kempler P, et al. Diabetic neuropathies: update on definitions, diagnostic criteria, estimation of severity, and treatments. *Diabetes Care*. 2010;33(10):2285–93.



- Tesfaye S, Vileikyte L, Rayman G, Sindrup S, Perkins B, Baconja M, et al. Painful diabetic peripheral neuropathy: consensus recommendations on diagnosis, assessment and management. *Diabetes Metab Res Rev.* 2011;27:629–38.
- Tesfaye S, Wilhelm S, Lledo A, Schacht A, Tolle T, Bouhassira D, et al. Duloxetine and pregabalin: high-dose monotherapy or their combination? The “COMBO-DN study” – a multinational, randomized, double-blind, parallel-group study in patients with diabetic peripheral neuropathic pain. *Pain.* 2013;154(12):2616–25.
- Thakral G, Kim PJ, LaFontaine J, Menzies R, Najafi B, Lavery LA. Electrical stimulation as an adjunctive treatment of painful and sensory diabetic neuropathy. *J Diabetes Sci Technol.* 2013;7(5):1202–9.
- The Consensus Committee of the American Autonomic Society and the American Academy of Neurology. Consensus statement on the definition of orthostatic hypotension, pure autonomic failure, and multiple system atrophy. *Neurology.* 1996;46(5):1470.
- The Diabetes Control and Complications Trial Research Group. The effect of intensive treatment of diabetes on the development and progression of long-term complications in insulin-dependent diabetes mellitus. *N Engl J Med.* 1993;329:977–86.
- Tolle T, Freynhagen R, Versavel M, Trostmann U, Young JJP. Pregabalin for relief of neuropathic pain associated with diabetic neuropathy: a randomized, double-blind study. *Eur J Pain.* 2008;12:203–13.
- Torrance N, Smith BH, Bennett MI, Lee AJ. The epidemiology of chronic pain of predominantly neuropathic origin. Results from a general population survey. *J Pain.* 2006;7(4):281–9.
- Toth C, Schmidt AM, Tuor UI, Francis G, Foniok T, Brussee V, et al. Diabetes, leukoencephalopathy and rage. *Neurobiol Dis.* 2006;23(2):445–61.
- Treede RD, Jensen TS, Campbell JN, Cruccu G, Dostrovsky JO, Griffin JW, et al. Neuropathic pain: redefinition and a grading system for clinical and research purposes. *Neurology.* 2008;70(18):1630–5.
- Tsai CP, Liu CY, Lin KP, Wang KC. Efficacy of botulinum toxin type a in the relief of Carpal tunnel syndrome: a preliminary experience. *Clin Drug Investig.* 2006;26(9):511–5.
- Turcot K, Allet L, Golay A, Hoffmeyer P, Armand S. Investigation of standing balance in diabetic patients with and without peripheral neuropathy using accelerometers. *Clin Biomech (Bristol, Avon).* 2009;24(9):716–21.
- Turgut N, Altun BU. Cortical disinhibition in diabetic patients with neuropathic pain. *Acta Neurol Scand.* 2009;120(6):383–8.
- Uccioli L, Giacomini PG, Monticone G, Magrini A, Durola L, Bruno E, et al. Body sway in diabetic neuropathy. *Diabetes Care.* 1995;18(3):339–44.
- UK Prospective Diabetes Study (UKPDS) Group. Intensive blood-glucose control with sulphonylureas or insulin compared with conventional treatment and risk of complications in patients with type 2 diabetes (UKPDS 33). *Lancet.* 1998;352:837–53.
- van den Berg E, de Craen AJ, Biessels GJ, Gussekloo J, Westendorp RG. The impact of diabetes mellitus on cognitive decline in the oldest of the old: a prospective population-based study. *Diabetologia.* 2006;49(9):2015–23.
- van den Berg E, Reijmer YD, de Bresser J, Kessels RP, Kappelle LJ, Biessels GJ. A 4 year follow-up study of cognitive functioning in patients with type 2 diabetes mellitus. *Diabetologia.* 2010;53(1):58–65.
- van Dijk PT, Meulenberg OG, van de Sande HJ, Habbema JD. Falls in dementia patients. *Gerontologist.* 1993;33(2):200–4.
- van Elderen SG, de Roos A, de Craen AJ, Westendorp RG, Blauw GJ, Jukema JW, et al. Progression of brain atrophy and cognitive decline in diabetes mellitus: a 3-year follow-up. *Neurology.* 2010;75(11):997–1002.
- van Seventer R, Feister HA, JrJP Y, Stoker M, Versavel M, Rigaudy L. Efficacy and tolerability of twice-daily pregabalin for treating pain and related sleep interference in postherpetic neuralgia: a 13-week, randomized trial. *Curr Med Res Opin.* 2006;22:375–84.
- Van AK, Bouhassira D, De BD, Weiss S, Matthys K, Raemen H, et al. Prevalence and impact on quality of life of peripheral neuropathy with or without neuropathic pain in type 1 and type 2 diabetic patients attending hospital outpatients clinics. *Diabetes Metab.* 2009;35(3):206–13.

- Vellas BJ, Wayne SJ, Romero LJ, Baumgartner RN, Garry PJ. Fear of falling and restriction of mobility in elderly fallers. *Age Ageing*. 1997;26(3):189–93.
- Veresiu AI, Bondor CI, Florea B, Vinik EJ, Vinik AI, Gavan NA. Detection of undisclosed neuropathy and assessment of its impact on quality of life: a survey in 25,000 Romanian patients with diabetes. *J Diabetes Complicat*. 2015;29(5):644–9.
- Veves A, Backonja M, Malik RA. Painful diabetic neuropathy: epidemiology, natural history, early diagnosis, and treatment options. *Pain Med*. 2008;9(6):660–74.
- Vileikyte L, Peyrot M, Bundy C, Rubin RR, Leventhal H, Mora P, et al. The development and validation of a neuropathy- and foot ulcer-specific quality of life instrument. *Diabetes Care*. 2003;26(9):2549–55.
- Vincent AM, Callaghan BC, Smith AL, Feldman EL. Diabetic neuropathy: cellular mechanisms as therapeutic targets. *Nat Rev Neurol*. 2011;7(10):573–83.
- Vinik AI. Treatment of diabetic polyneuropathy (DPN) with recombinant human nerve growth factor (rhNGF). *Diabetes*. 1999;48(Suppl 1):A54–5.
- Vinik AI. Diabetic neuropathies: endpoints in clinical research studies. In: LeRoith D, Vinik AI, editors. *Contemporary endocrinology: controversies in treating diabetes: clinical and research aspects*. Totowa: Humana Press; 2008. p. 135–56.
- Vinik A. The approach to the management of the patient with neuropathic pain. *J Clin Endocrinol Metab*. 2010;95(11):4802–11.
- Vinik AI. The conductor of the autonomic orchestra. *Front Endocrinol*. 2012;71:1–13.
- Vinik AI. Clinical Practice. Diabetic sensory and motor neuropathy. *N Engl J Med*. 2016; 374(15):1455–64.
- Vinik AI, Casellini CM. Guidelines in the management of diabetic nerve pain: clinical utility of pregabalin. *Diabetes Metab Syndr Obes*. 2013;6:57–78.
- Vinik A, Mehrabyan A. Diabetic Neuropathies. *Med Clin North Am*. 2004;88(4):947–99.
- Vinik AI, Ziegler D. Diabetic cardiovascular autonomic neuropathy. *Circulation*. 2007; 115(3):387–97.
- Vinik AI, Mitchell BD, Leichter SB, Wagner AL, O'Brian JT, Georges LP. Epidemiology of the complications of diabetes. In: Leslie RDG, Robbins DC, editors. *Diabetes: clinical science in practice*. Cambridge, UK: Cambridge University Press; 1995a. p. 221–87.
- Vinik AI, Suwanwalaikorn S, Stansberry KB, Holland MT, McNitt PM, Colen LE. Quantitative measurement of cutaneous perception in diabetic neuropathy. *Muscle Nerve*. 1995b;18: 574–84.
- Vinik A, Mehrabyan A, Colen L, Boulton A. Focal entrapment neuropathies in diabetes. *Diabetes Care*. 2004;27(7):1783–8.
- Vinik EJ, Hayes RP, Oglesby A, Bastyr E, Barlow P, Ford-Molvik SL, et al. The development and validation of the Norfolk QOL-DN, a new measure of patients' perception of the effects of diabetes and diabetic neuropathy. *Diabetes Technol Ther*. 2005;7(3):497–508.
- Vinik A, Ullal J, Parson HK, Casellini CM. Diabetic neuropathies: clinical manifestations and current treatment options. *Nat Clin Pract Endocrinol Metab*. 2006;2(5):269–81.
- Vinik E, Paulson J, Ford-Molvik S, Vinik A. German-Translated Norfolk Quality of Life (QOL-DN) identifies the same factors as the English version of the tool and discriminates different levels of neuropathy severity. *J Diabetes Sci Technol*. 2008a;2(6):1075–86.
- Vinik AI, Strotmeyer ES, Nakave AA, Patel CV. Diabetic neuropathy in older adults. *Clin Geriatr Med*. 2008b;24(3):407–35. v
- Vinik AI, Maser RE, Ziegler D. Neuropathy: the crystal ball for cardiovascular disease? *Diabetes Care*. 2010a;33(7):1688–90.
- Vinik A, Zlateva G, Cheung R, Murphy K, Emir B, Whalen E. Understanding the impact of pain response on changes in function, quality of life, and sleep interference in patients with painful diabetic peripheral neuropathy and post-herpetic neuralgia treated with pregabalin. In: American Pain Society 29th annual scientific meeting. 2010b. Baltimore. Ref Type: Abstract.
- Vinik AI, Maser RE, Ziegler D. Autonomic imbalance: prophet of doom or scope for hope? *Diabet Med*. 2011;28(6):643–51.

- Vinik A, Nevoret M-L, Casellini C, Parson H. Diabetic neuropathy. In: Poretzky L, Liao E, editors. Acute and chronic complications of diabetes. Philadelphia: Elsevier; 2013. p. 747–87. *Endocrinol Metab Clin N Am*.
- Vinik A, Shapiro D, Rauschkolb C, Lange B, Karcher K, Pennett D. A randomized-withdrawal, placebo-controlled study evaluating the efficacy and tolerability of tapentadol extended release in patient with chronic, painful diabetic peripheral neuropathy. *Diabetes Care*. 2014;37:2302.
- Vinik AI, Vinik EJ, Colberg SR, Morrison S. Falls risk in older adults with type 2 diabetes. In: Strotmeyer S, editor. Diabetes and aging, Clinics in geriatric medicine. Philadelphia: Elsevier; 2015. p. 89–99.
- Vinik AI, Perrot S, Vinik EJ, Pazdera L, Jacobs H, Stoker M, et al. Capsaicin 8% patch repeat treatment plus standard of care (SOC) versus SOC alone in painful diabetic peripheral neuropathy: a randomised, 52-week, open-label, safety study. *BMC Neurol*. 2016;16(1):251.
- Vischer UM, Bauduceau B, Bourdel-Marchasson I, Blickle JF, Constans T, Fagot-Campagna A, et al. A call to incorporate the prevention and treatment of geriatric disorders in the management of diabetes in the elderly. *Diabete Metab*. 2009;35(3):168–77.
- Volpato S, Leveille SG, Blaum C, Fried LP, Guralnik JM. Risk factors for falls in older disabled women with diabetes: the women's health and aging study. *J Gerontol A Biol Sci Med Sci*. 2005;60(12):1539–45.
- Volpato S, Maraldi C, Fellin R. Type 2 diabetes and risk for functional decline and disability in older persons. *Curr Diabetes Rev*. 2010;6(3):134–43.
- Wackers FJ, Young LH, Inzucchi SE, Chyun DA, Davey JA, Barrett EJ, et al. Detection of silent myocardial ischemia in asymptomatic diabetic subjects: the DIAD study. *Diabetes Care*. 2004;27(8):1954–61.
- Walker ML, Morrison S, Colberg SR. Supervised exercise leads to improved reactions, balance and reduced falls risk in older adults with type 2 diabetes: 2946 board #11 June 3, 2: 00 PM – 3: 30 PM. *Med Sci Sports Exerc*. 2016;48(5 Suppl 1):828.
- Watanabe K, Hagura R, Akanuma Y, Takasu T, Kajinuma H, Kuzuya N, et al. Characteristics of cranial nerve palsies in diabetic patients. *Diabetes Res Clin Pract*. 1990;10(1):19–27.
- Watson CP, Moulin D, Watt-Watson J, Gordon A, Eisenhoffer J. Controlled-release oxycodone relieves neuropathic pain: a randomized controlled trial in painful diabetic neuropathy. *Pain*. 2003;105(1-2):71–8.
- Wautier JL, Guillausseau PJ. Advanced glycation end products, their receptors and diabetic angiopathy. *Diabete Metab*. 2001;27:535–42. Ref Type: Generic
- Wernicke JF, Pritchett YL, D'Souza DN, Waninger A, Tran P, Iyengar S, et al. A randomized controlled trial of duloxetine in diabetic peripheral neuropathic pain. *Neurology*. 2006; 67(8):1411–20.
- Whitmer RA, Karter AJ, Yaffe K, Quesenberry CP Jr, Selby JV. Hypoglycemic episodes and risk of dementia in older patients with type 2 diabetes mellitus. *JAMA*. 2009;301(15):1565–72.
- WHO Press Conference. Global report on diabetes. Geneva. <http://www.who.int/diabetes/global-report/en/2016>. Accessed 26 Jan 2017.
- Wilbourn AJ. Diabetic entrapment and compression neuropathies. In: Dyck PJ, Thomas PK, editors. Diabetic neuropathy. Philadelphia: Saunders; 1999. p. 481–508.
- Witzke KA, Vinik AI. Diabetic neuropathy in older adults. *Rev Endocr Metab Disord*. 2005; 6(2):117–27.
- Witzke KA, Vinik AI. Charcot neuroarthropathy may be the RAGE. *Diabetes Technol Ther*. 2012; S1:005.
- Witzke K, Vinik A, Grant L, Parson H, Pittenger G. Loss of RAGE defense: a cause of charcot neuroarthropathy? *Diabetes Care*. 2011;34:1617. Submitted
- Woolcott JC, Richardson KJ, Wiens MO, Patel B, Marin J, Khan KM, et al. Meta-analysis of the impact of 9 medication classes on falls in elderly persons. *Arch Intern Med*. 2009; 169(21):1952–60.
- Wootton-Gorges SL, Buonocore MH, Kuppermann N, Marcin J, Dicarolo J, Neely EK, et al. Detection of cerebral  $\beta$ -hydroxy butyrate, acetoacetate, and lactate on proton MR spectroscopy in children with diabetic ketoacidosis. *AJNR Am J Neuroradiol*. 2005;26(5):1286–91.

- Wu T, Ahmed A, Bril V, Orszag A, Ng E, Nwe P, et al. Variables associated with corneal confocal microscopy parameters in healthy volunteers: implications for diabetic neuropathy screening. *Diabet Med.* 2012;29(9):e297–303.
- Wulsin LR, Horn PS, Perry JL, Massaro J, D'Agostino R. Autonomic imbalance as a predictor of metabolic risks, cardiovascular disease, diabetes, and mortality: autonomic imbalance predicts CVD, DM, mortality. *J Clin Endocrinol Metab.* 2015;100(6):2443–8.
- Yaffe K, Falvey C, Hamilton N, Schwartz AV, Simonsick EM, Satterfield S, et al. Diabetes, glucose control, and 9-year cognitive decline among older adults without dementia. *Arch Neurol.* 2012;69(9):1170–5.
- Yan SD, Fu J, Soto C, Chen X, Zhu H, Al-Mohanna F, et al. An intracellular protein that binds amyloid-beta peptide and mediates neurotoxicity in Alzheimer's disease. *Nature.* 1997;389(6652):689–95.
- Yan SF, Ramasamy R, Schmidt AM. Receptor for AGE (RAGE) and its ligands—cast into leading roles in diabetes and the inflammatory response. *J Mol Med.* 2009;87(3):235–47.
- Yoshitake T, Kiyohara Y, Kato I, Ohmura T, Iwamoto H, Nakayama K, et al. Incidence and risk factors of vascular dementia and Alzheimer's disease in a defined elderly Japanese population: the Hisayama Study. *Neurology.* 1995;45(6):1161–8.
- Young RJ. Structural functional interactions in the natural history of diabetic polyneuropathy: a key to the understanding of neuropathic pain? *Diabet Med.* 1993;10(Suppl 2):89S–90S.
- Young RJ, Ewing DJ, Clarke BF. Chronic and remitting painful diabetic polyneuropathy. Correlations with clinical features and subsequent changes in neurophysiology. *Diabetes Care.* 1988;11(1):34–40.
- Young MJ, Boulton AJM, MacLeod AF, Williams DRR, Sonksen PH. A multicenter study of the prevalence of diabetic peripheral neuropathy in the United Kingdom hospital clinic population. *Diabetologia.* 1993;36:150–4.
- Young LH, Wackers FJ, Chyun DA, Davey JA, Barrett EJ, Taillefer R, et al. Cardiac outcomes after screening for asymptomatic coronary artery disease in patients with type 2 diabetes: the DIAD study: a randomized controlled trial. *JAMA.* 2009;301(15):1547–55.
- Yuan RY, Sheu JJ, Yu JM, Chen WT, Tseng JJ, Chang HH, et al. Botulinum toxin for diabetic neuropathic pain: a randomized double-blind crossover trial. *Neurology.* 2009;72(17):1473–8.
- Zafir B, Azencot M, Dobrecky-Mery I, Lewis BS, Flugelman MY, Halon DA. Resting heart rate and measures of effort-related cardiac autonomic dysfunction predict cardiovascular events in asymptomatic type 2 diabetes. *Eur J Prev Cardiol.* 2016;23(12):1298–306.
- Zelman DC, Brandenburg NA, Gore M. Sleep impairment in patients with painful diabetic peripheral neuropathy. *Clin J Pain.* 2006;22(8):681–5.
- Zenker J, Ziegler D, Chrast R. Novel pathogenic pathways in diabetic neuropathy. *Trends Neurosci.* 2013;36(8):439–49.
- Zhao WQ, Townsend M. Insulin resistance and amyloidogenesis as common molecular foundation for type 2 diabetes and Alzheimer's disease. *Biochim Biophys Acta.* 2009;1792(5):482–96.
- Ziegler D, Hanefeld M, Ruhnau KJ, Meissner HP, Lobisch M, Schutte K, et al. Treatment of symptomatic diabetic peripheral neuropathy with the anti-oxidant alpha-lipoic acid. A 3-week multicentre randomized controlled trial (ALADIN study). *Diabetologia.* 1995;38(12):1425–33.
- Ziegler D, Sohr CG, Nourooz-Zadeh J. Oxidative stress and antioxidant defense in relation to the severity of diabetic polyneuropathy and cardiovascular autonomic neuropathy. *Diabetes Care.* 2004a;27(9):2178–83.
- Ziegler D, Nowak H, Kempler P, Vargha P, Low PA. Treatment of symptomatic diabetic polyneuropathy with the antioxidant alpha-lipoic acid: a meta-analysis. *Diabet Med.* 2004b;21(2):114–21.
- Ziegler D, Ametov A, Barinov A, Dyck PJ, Gurieva I, Low PA, et al. Oral treatment with alpha-lipoic acid improves symptomatic diabetic polyneuropathy: the SYDNEY 2 trial. *Diabetes Care.* 2006;29(11):2365–70.
- Ziegler D, Pritchett YL, Wang F, Desai D, Robinson MJ, Hall JA, et al. Impact of disease characteristics on the efficacy of duloxetine in diabetic peripheral neuropathic pain. *Diabetes Care.* 2007;30(3):664–9.

- Ziegler D, Rathmann W, Dickhaus T, Meisinger C, Mielck A. Prevalence of polyneuropathy in pre-diabetes and diabetes is associated with abdominal obesity and macroangiopathy: the MONICA/KORA Augsburg Surveys S2 and S3. *Diabetes Care*. 2008a;31(3):464–9.
- Ziegler D, Zentai CP, Perz S, Rathmann W, Haastert B, Doring A, et al. Prediction of mortality using measures of cardiac autonomic dysfunction in the diabetic and nondiabetic population: the MONICA/KORA Augsburg cohort study. *Diabetes Care*. 2008b;31(3):556–61.
- Ziegler D, Rathmann W, Dickhaus T, Meisinger C, Mielck A. Neuropathic pain in diabetes, prediabetes and normal glucose tolerance: the MONICA/KORA Augsburg Surveys S2 and S3. *Pain Med*. 2009a;10(2):393–400.
- Ziegler D, Rathmann W, Meisinger C, Dickhaus T, Mielck A. Prevalence and risk factors of neuropathic pain in survivors of myocardial infarction with pre-diabetes and diabetes. The KORA Myocardial Infarction Registry. *Eur J Pain*. 2009b;13(6):582–7.
- Ziegler D, Low PA, Litchy WJ, Boulton AJ, Vinik AI, Freeman R, et al. Efficacy and safety of antioxidant treatment with alpha-lipoic acid over 4 years in diabetic polyneuropathy: the NATHAN 1 trial. *Diabetes Care*. 2011;34(9):2054–60.
- Ziegler D, Papanas N, Vinik AI, Shaw JE. Epidemiology of polyneuropathy in diabetes and prediabetes. In: Zochodne DW, Malik RA, editors. *Diabetes and the nervous system, Handbook of clinical neurology*. 3rd ed. Edinburgh: Elsevier; 2014a. p. 3–22.
- Ziegler D, Papanas N, Zhivov A, Allgeier S, Winter K, Ziegler I, et al. Early detection of nerve fiber loss by corneal confocal microscopy and skin biopsy in recently diagnosed type 2 diabetes. *Diabetes*. 2014b;63(7):2454–63.
- Ziegler D, Voss A, Rathmann W, Strom A, Perz S, Roden M, et al. Increased prevalence of cardiac autonomic dysfunction at different degrees of glucose intolerance in the general population: the KORA S4 survey. *Diabetologia*. 2015a;58(5):1118–28.
- Ziegler D, Duan WR, An G, Thomas JW, Nothhaft W. A randomized double-blind, placebo-, and active-controlled study of T-type calcium channel blocker ABT-639 in patients with diabetic peripheral neuropathic pain. *Pain*. 2015b;156(10):2013–20.
- Ziegler D, Low PA, Freeman R, Tritschler H, Vinik AI. Predictors of improvement and progression of diabetic polyneuropathy following treatment with alpha-lipoic acid for 4years in the NATHAN 1 trial. *J Diabetes Complicat*. 2016;30(2):350–6.
- Zinman LH, Bril V, Perkins BA. Cooling detection thresholds in the assessment of diabetic sensory polyneuropathy: comparison of CASE IV and Medoc instruments. *Diabetes Care*. 2004; 27(7):1674–9.
- Zochodne D, Toth C. Diabetes and the nervous system. In: Aminoff's neurology and general medicine. 5th ed. Amsterdam: Academic; 2014. p. 351–68.



Frank Lee Bowling and Andrew J. M. Boulton

## Contents

Introduction .....	357
Diabetic Peripheral Neuropathy (DPN) .....	358
Distal Symmetrical Sensorimotor Peripheral Neuropathy .....	358
Peripheral Sympathetic Autonomic Neuropathy .....	358
Other Long-Term Risk Factors for Foot Ulceration .....	358
Peripheral Vascular Disease .....	359
Epidemiology of Diabetic Foot Problems .....	359
Prevention of Diabetes-Related Foot Complications .....	360
Identification of the High-Risk Foot .....	361
Assessment .....	361
History .....	361
Clinical Examination .....	361
Neurological Assessment .....	362
Vascular Assessment .....	362

---

F. L. Bowling (✉)

Division of Endocrinology, Diabetes and Gastroenterology, Faculty of Medicine, Biology and Health, University of Manchester, Manchester, UK

Division of Surgery, Manchester Royal Infirmary, Manchester, UK  
e-mail: [frank.bowling@manchester.ac.uk](mailto:frank.bowling@manchester.ac.uk)

A. J. M. Boulton

Division of Endocrinology, Diabetes and Gastroenterology, Faculty of Medicine, Biology and Health, University of Manchester, Manchester, UK

Manchester Royal Infirmary, Manchester, UK

Diabetes Research Institute, University of Miami, Miami, FL, USA  
e-mail: [ABoulton@med.miami.edu](mailto:ABoulton@med.miami.edu)

The High-Risk Patient .....	363
Wound Classification .....	363
Management of Diabetic Foot Ulceration .....	364
Neuropathic Ulcers .....	364
Debridement .....	364
Off-Loading .....	364
Neuro-Ischemic Ulcers .....	365
Infection .....	365
Wound Dressings .....	366
Negative-Pressure Wound Therapy .....	368
Growth Factors and Skin Substitutes .....	368
Hyperbaric Oxygen Therapy .....	368
Charcot Neuroarthropathy .....	369
Patient Education .....	371
Multidisciplinary Team Input .....	371
Summary .....	372
Conclusions .....	372
References .....	373

### Abstract

Diabetic foot problems are eminently preventable and yet represent one of the commonest causes of hospital inpatient admission in Western countries. Realizing the global importance of diabetic foot disease, the International Diabetes Federation focused on the diabetic foot throughout the year 2005, during which there was a worldwide campaign to “put feet first” and highlight the all too common problem of amputation among patients with diabetes throughout the world. To coincide with World Diabetes Day in 2005, *The Lancet* launched an issue almost exclusively dedicated to the diabetic foot: this was the first time that any major nonspecialist journal had focused on this worldwide problem; however, major challenges remain in getting across important messages relating to the diabetic foot. The late sequelae of diabetic peripheral neuropathy include foot ulceration, Charcot neuroarthropathy, and amputation: likewise, peripheral vascular disease is a major etiological factor in diabetic foot lesions. Today, in many countries, it is neuro-ischemic ulcers which are most commonly seen and which present a major challenge in management. The importance of routine diabetic foot care in very high-risk patients is emphasized by a recent observational study from Arizona where the state decided, as a cost-saving measure, to remove routine podiatry from high-risk diabetic patients. This led to an annual saving of \$351,000, but the cost of this action measured by increased hospitalization, length of stay, and amputations was \$16.7 million per annum.

### Keywords

Diabetes · Peripheral vascular disease · Charcot neuroarthropathy · Diabetic peripheral neuropathy

## Introduction

Diabetic foot problems are eminently preventable and yet represent one of the commonest causes of hospital inpatient admission in Western countries. Realizing the global importance of diabetic foot disease, the International Diabetes Federation (IDF) focused on the diabetic foot throughout the year 2005, during which there was a worldwide campaign to “put feet first” and highlight the all too common problem of amputation among patients with diabetes throughout the world. To coincide with World Diabetes Day in 2005, *The Lancet* launched an issue almost exclusively dedicated to the diabetic foot: this was the first time that any major nonspecialist journal had focused on this worldwide problem; however, major challenges remain in getting across important messages relating to the diabetic foot (Boulton et al. 2005). The late sequelae of diabetic peripheral neuropathy (DPN) include foot ulceration, Charcot neuroarthropathy (CN), and amputation: likewise, peripheral vascular disease (PVD) is a major etiological factor in diabetic foot lesions. Today, in many countries, it is neuro-ischemic ulcers which are most commonly seen and which present a major challenge in management. The importance of routine diabetic foot care in very high-risk patients is emphasized by a recent observational study from Arizona where the state decided, as a cost-saving measure, to remove routine podiatry from high-risk diabetic patients. This led to an annual saving of \$351,000, but the cost of this action measured by increased hospitalization, length of stay, and amputations was \$16.7 million per annum (Skrepnek et al. 2014).

The treatment and overall healthcare management of patients with diabetes and foot complications are a prolonged, time-consuming process that requires the involvement of a team of healthcare professionals dedicated to foot health. Singh et al. concluded that 25% of people with diabetes will develop a foot ulcer during the course of their life (Singh et al. 2005). A non-healing foot ulcer complicated by infection is estimated to precede 85% of lower limb amputations (Pecoraro et al. 1990). Foot ulcers can be a lifelong affliction requiring multiple treatment regimens and highly specialized clinicians: indeed, as recurrent foot ulcers are so common, it has recently been suggested that those with a previous foot ulcer history should be described as being in “remission” rather than “healed” in order to help patients appreciate the seriousness of a foot ulcer history (Armstrong et al. 2017).

Economic burdens both nationally and internationally can be extremely high. Recent UK data suggests an annual cost of over \$749 million for the diabetic foot (Jeffocate and Young 2016). The financial strain also appears to be influenced by the specific type of ulcer being treated as illustrated in the Eurodiale study (Prompers et al. 2008) which reported an average spend of \$13,000 for treating non-infected foot ulcers increasing to \$18,000 for infected ulcers with concurrent peripheral arterial disease. A severely infected foot ulcer refractory to treatment can be predicted to incur higher costs still. Calculations, incorporating multiple failed antibiotic regimens, hospital admission for intravenous antibiotics, management of sepsis, attempted limb salvage, and major limb amputation with associated aftercare yielded a total sum of \$188,645 (Cavanagh et al. 2012).



## Diabetic Peripheral Neuropathy (DPN)

DPN increases the risk of foot ulceration through the loss of protective sensation, in the absence of which patients become vulnerable to trauma (Reiber et al. 1999). Soft tissue trauma is a major causative factor in the development of diabetic foot ulceration in patients with DPN (Boulton 2005). DPN is also associated with an increased risk of falls and alterations in foot architecture. Unlike their healthy counterparts, people with DPN are less likely to notice cuts, grazes, puncture wounds, etc., in the lower extremities due to the loss of protective sensation. The inextricable link between soft tissue trauma and DPN underpins a sevenfold increased risk of first foot ulceration that affects those with DPN compared to diabetic non-neuropathic subjects (Young et al. 1994). (For further detailed discussion of DPN, the reader is referred to ► [Chap. 8, “Diabetes and the Eye”](#).)

## Distal Symmetrical Sensorimotor Peripheral Neuropathy

The symptoms of sensorimotor peripheral neuropathy can be broadly divided into painful and painless forms, although it is possible to experience both simultaneously. Individuals may describe reduced or absent sensation in the lower limb, burning, tingling, stabbing sensation, pain, paresthesia, and a sensation of walking on marbles. In contrast, others may experience numbness, heaviness, or not uncommonly may be asymptomatic (Boulton et al. 2004), until examination reveals a profound sensory loss, thus exposing the high-risk foot. As up to 50% of neuropathic diabetic patients may not complain of any symptomatology whatsoever, the “at risk of ulceration” diabetic foot cannot be identified without a careful examination of both feet with shoes and socks removed.

## Peripheral Sympathetic Autonomic Neuropathy

Autonomic dysfunction in the diabetic lower extremity can manifest as anhidrosis predisposing the foot to callus formation beneath weight-bearing areas of the foot (Tentolouris et al. 2009). Autonomic neuropathy also frequently results in a state referred to as “auto-sympathectomy” that leads to the release of sympathetic vasoconstrictor tone resulting in arteriovenous shunting and a warm well-perfused foot. A useful clinical sign of the presence of “auto-sympathectomy” and the absence of peripheral vascular disease is distended dorsal foot veins that remain distended on elevation of the foot. Thus it is the warm, insensate, and often painless foot that is very much the “at-risk foot.”

---

## Other Long-Term Risk Factors for Foot Ulceration

Renal disease, even in the preliminary stage of microalbuminuria, is a strong predictor of foot ulceration (Ndip et al. 2010). Those most at risk are patients with end-stage renal disease who are on dialysis (Lavery et al. 2015). Patients who have

undergone renal transplants-combined pancreas–kidney transplants are still at high risk of ulceration post-transplant and should be monitored for long-term foot complications. Although such patients may have normoglycemia and relatively normal renal function, they still have the major risk factors for foot ulceration and other end-stage complications of neuropathy. Such patients often become more active because of their overall better health status, and there have been reports of foot ulcers and even acute Charcot neuroarthropathy in patients some years after simultaneous pancreas–kidney transplantation.

Architectural changes expose the foot to areas of high pressure. Flexion deformities of the digits, hallux valgus, and migration of the plantar fat pad into the sulcus increase the risk of tissue breakdown.

Few studies have examined the role of psychosocial factors in the pathway to foot ulceration, but it appears that patients' behavior is not driven by the abstract designation of being "at risk": it is driven by patients' perception of their risk (Vileikyte 2008). More recently, a prospective study has confirmed that depression predicts first, although not recurrent, diabetic foot ulcers (Gonzalez et al. 2010).

---

## Peripheral Vascular Disease

Peripheral ischemia is frequently one of the component causes that is pivotal in the pathway to ulceration, and in recent years, the percentage of foot ulcers presenting with neuropathy and ischemia has increased in Western countries (Schaper et al. 2012). The specific role of PVD in ulcer pathogenesis is difficult to determine due to the asymptomatic nature of the disease process in the early stages. Patients tend only to seek healthcare advice once they become symptomatic with or without tissue loss. Presenting ulcers, whether infected or not, have increased perfusion demands, but an underlying paucity in supply may decrease the likelihood of healing. Neuro-ischemic ulcers tend to be deep seated and have a larger area of soft tissue and bone loss than neuropathic ulcers. PVD, especially in the presence of infection, is also associated with increased rates of amputation and mortality. Reducing the risks of developing PVD through structured education programs, i.e., smoking cessation, physical exercise, and healthy diet, has the potential to reduce disease incidence.

---

## Epidemiology of Diabetic Foot Problems

In the UK, the annual incidence and prevalence of foot ulceration in patients with diabetes were calculated at 2.2% and 1.7%, respectively, in 2002 (Abbott et al. 2002). Later, a European multicenter study on Diabetes and the Lower Extremity (Eurodiale) (Prompers et al. 2008) followed 1232 diabetes patients with a foot ulcer for 12 months and found that 5% of these underwent a major amputation (above or below knee) during the follow-up period. Krishnan et al. (2008) reported an amputation rate of 16.5 per 10,000 people with diabetes in the UK. Data extracted from the General Physicians databases in Scotland identified that 2.5% of the diagnosed diabetes population had an active foot ulcer at the beginning of

December 2010 (Leese et al. 2011). Diabetic foot disease is associated with a risk of amputation 23 times that of a person without diabetes (Holman et al. 2012).

There are a few databases that capture diabetic foot ulceration as a distinct entity, but Diabetes UK used data from the Public Health Observatory and National Diabetes In-patient Audit (Health and Social Care Information Centre 2013) to estimate the cost of inpatient care for complicated diabetic foot ulcers (DFUs). For the period 2010–2011, expenditure was £219 million (\$285 million) (Diabetes UK 2014). Amputations are expensive due to surgical and inpatient bed use, but financial models of total treatment costs for DFU management versus amputation management have demonstrated that complex DFUs are substantially more expensive than amputations (Kerr et al. 2014).

---

## Prevention of Diabetes-Related Foot Complications

The ideal intervention for diabetic lower limb complications should be prevention. One of the key messages in the UK National Institute for Health and Care Excellence (NICE) guidelines on type 2 diabetes (National Institute for Clinical Excellence 2004) is self-management, whereby patients are educated regarding specific aspects of their condition, thus empowering them to share in the responsibility for their health through self-monitoring. The aim is to achieve an increased awareness, facilitating improved compliance with professional advice, which should ultimately lead to a reduction in complications. Education programs, as recommended in the National Service Framework (NSF) for Diabetes (Department of Health 2010) and NICE (National Institute for Clinical Excellence 2004), have attempted to achieve patient self-management through education sessions from the diabetes multidisciplinary team.

To date, the only intervention proven to halt or reduce the development of diabetes-related complications is strict glycaemic control, as reported in the Diabetes Control and Complications Trial (The Diabetes Control and Complications Research Group 1993). No other treatment has demonstrated such a profound impact on clinical diabetic complications, including reduced onset of retinopathy, nephropathy, and neuropathy over 6.5 years, and, as a result, glycaemic control remains at the forefront of diabetes management (Inzucchi et al. 2015).

In practice, DPN remains a major cause of diabetic foot ulceration. Treatment of DFUs is based on a sound understanding of the physiological changes that occur in the lower limb as a result of diabetes. However, prevention is always more preferable than attempting to heal an acute or chronic ulcer. Targeting prevention through daily self-inspection of the feet for signs of injury is just one example of risk reduction. Falling in the home or outside and an associated soft tissue injury could be the catalyst for foot ulceration and the development of acute CN. Ulcers can have a devastating impact on a patient's quality of life and psychological profile, not to mention the economic considerations to the healthcare provider (Vileikyte et al. 2004).

## Identification of the High-Risk Foot

Patients with diabetic peripheral neuropathy are highly vulnerable to tissue loss having lost their protective sensation “awareness”: similarly, regular screening for the presence of PVD is also essential. An annual review by a healthcare professional is vital, but the patient also has a responsibility to actively engage in this process through regular monitoring of their own feet.

## Assessment

Up to 50% of older, type 2 diabetic patients have signs of DPN identifiable through proper assessment (Pop-Busui et al. 2017). Guidance can be sought from the American Diabetes Association (ADA) document on the “Comprehensive Diabetic Foot Examination (CDFE)” (Boulton et al. 2008) which provides clarity on the structure and content of a robust assessment. Similarly, PVD may be “silent” in diabetic patients, and assessment of the peripheral circulation is also a pivotal part of the annual review.

A foot examination is the key component of the diabetic foot check and should be placed in the context of a thorough history that identifies specific risk factors for foot ulceration.

## History

- Past or present neuropathic symptoms
- Vascular (intermittent claudication/rest pain/past history of bypass surgery or angioplasty)
- History of ulcer or minor/major amputation
- Social factors (living alone, smoking)
- Visual impairment or end-stage renal failure (dialysis or post-transplant)

## Clinical Examination

- Skin color, callus, fissures, reduced sweating.
- Bacterial/fungal infection.
- Ulceration?
- Architecture/structural alterations, claw toes, prominent metatarsal heads.
- Anhidrosis.
- Skin temperature: a unilateral, warm, insensate foot should be considered to be acute Charcot neuroarthropathy (CN) until proven otherwise.
- Footwear suitability.

## Neurological Assessment

The following tests focus on neuropathy affecting large nerve fibers with an emphasis on ease of administration, portability, ease of decontamination, and speed to carry out in order to meet the demands of annual foot reviews. The 10 g monofilament (Bailey Instruments Ltd., Manchester, UK) is widely used in clinical practice to test pressure perception. It consists of a small length of nylon designed to buckle when a 10 g force is applied: thus the filament is applied to the first, third, and fifth metatarsal heads and the plantar surface of the distal hallux. Patients are asked to respond yes or no regarding whether they have detected the stimulus. A number of studies (Vela et al. 1998; Valk et al. 1997) have demonstrated it is a reliable and highly accurate predictor of foot ulceration.

Other neurological screening tools include the Ipswich Touch Test, which requires the clinician to use their index finger to apply light touch to the tips of the first, third, and fifth toes. Neuropathy is identified when detection of sensation fails at two or more sites (out of the total six). Care should be taken not to provide any additional stimulation to the test area by way of tapping, pushing, or prodding. Although highly simplistic, it has demonstrated strong agreement with other validated tests such as the monofilament (Rayman et al. 2011). The VibraTip™ (McCallan Medical, Nottingham, UK) is a small, battery-operated, disposable vibrating stylus that assesses vibration sensation. It has a battery life of a number of months and is easily cleaned. Levels of agreement with other similar tests are excellent (Bowling et al. 2012).

Vibration perception testing (VPT) uses a handheld device that generates a vibratory stimulus which is applied to the hallux. Objective values for thresholds of vibration perception are obtained and can be used to monitor subsequent deterioration in nerve function. VPT has demonstrated excellent sensitivity and specificity for neuropathy.

A 128 Hz tuning fork is a traditional method of assessing vibration perception when placed over the apices of the hallux bilaterally. It has the advantage of being less expensive than the electrical devices for perception threshold testing but can be cumbersome and prone to misuse. The cold temperature from the metal is also providing additional stimuli in the form of temperature.

A pinprick test is a simple means of testing sensation using a disposable pin over the apex of the halluces. Ankle reflex testing is a standard component of neurological testing whereby the absence of ankle reflexes bilaterally is an abnormal response.

## Vascular Assessment

Screening for vascular disease can be difficult in diabetes as many are either asymptomatic or report atypical symptoms. Nevertheless, patients should be questioned about a current or previous history of intermittent claudication or ischemic rest pain. Any history of peripheral vascular procedures including bypass surgery or angioplasty should be recorded.

Palpation for posterior tibial and dorsalis pedis pulses is important, but detection can be influenced by the skill of the clinician and room temperature, so results should be considered within this context. A femoral bruit can also be a strong indicator of peripheral vascular disease.

The use of a Doppler ultrasound probe can be useful to assess flow signal waveforms, although vessel wall calcification can lead to a falsely elevated reading of the ankle-brachial index (ABI).

## The High-Risk Patient

Abnormalities identified from the screening tests above or relevant clinical history place an individual at high risk of foot ulceration necessitating the implementation of a number of strategies aimed at risk management. Education of patients is a vital component of ulcer prevention as it promotes self-monitoring and foot hygiene. However, this needs to be supported by regular podiatry and review by the multidisciplinary team.

## Wound Classification

The American Diabetes Association guidelines consider size, depth, appearance, and location as important factors to consider in the description of ulcers. Over the past two decades, a number of classification systems have emerged, and these provide the clinician with a reference point for wound monitoring. For describing diabetic foot ulcers, perhaps the most widely used is the Wagner Ulcer Classification System which grades wound depth and tissue necrosis; however, ischemia and infection are not included. The University of Texas classification incorporates all of these parameters resulting in accurate ulcer staging and reliable outcome prediction (Oyibo et al. 2001). See Table 1 for details.

**Table 1** Wound classification. The “University of Texas Diabetic Wound Classification” is regularly used for staging diabetic foot ulcers. This classification grades and stages ulcers by their depth and the presence of any infection or ischemia

• Staging
A: No infection or ischemia
B: Infection present
C: Ischemia present
D: Infection and ischemia present
• Grading
0: Epithelialized wound
1: Superficial wound
2: Wound penetrates to the tendon or capsule
3: Wound penetrates to the bone or joint

## Management of Diabetic Foot Ulceration

### Neuropathic Ulcers

The treatment of the majority of uncomplicated diabetic foot ulcers consists of debridement of nonviable tissues and an appropriate dressing tailored to the requirements of the individual wound, followed by an optimal off-loading technique (Bakker et al. 2016).

### Debridement

The development of hyperkeratotic tissue is a result of shear pressure, and regular removal of this excess callus reduces abnormally high plantar pressures. Wounds with extensive bone and soft tissue involvement require deeper and more aggressive debridement to remove nonviable tissue and provide drainage of purulent discharge. Complete surgical excision can significantly reduce the number of days taken to heal compared with ulcers managed more conservatively.

### Off-Loading

This is, perhaps, the key to healing diabetes-related foot ulcers, and outcomes are often positive when off-loading advice is followed. Total contact casts are the gold standard for off-loading, based on evidence of a 90% success rate for ulcer healing, as supported by several randomized controlled trials (Armstrong et al. 2003, 2005; Piaggese et al. 2007). Other off-loading devices, such as a removable cast walker or adapted footwear, have not demonstrated the same degree of success. The reason for the variation in healing rates was revealed in a study by Armstrong et al. (Armstrong et al. 2003) who covertly recorded the activity levels of patients while they wore a prescribed removable cast walker as treatment for neuropathic foot ulcers. Findings demonstrated that patients only wore the off-loading device for 28% of their total daily activity. Persistence with weight bearing on a diabetic neuropathic foot ulcer will undoubtedly prevent healing and, in most cases, promote further deterioration. A total contact cast, on the other hand, provides the foot with an alternative means of protection in the absence of normal sensation. This was confirmed in two parallel randomized controlled trials carried out in Miami and Tucson. In Miami, patients with non-infected neuropathic plantar ulcers were randomized either to a total contact cast or a removable cast walker rendered irremovable by wrapping with a sheet of cast material. Not surprisingly, there were no differences in healing rates which were generally rapid (Katz et al. 2005). By contrast, in the Tucson study, where patients were randomized either to a total contact cast or a removable cast walker, healing rates were much more rapid in the total contact cast group as the removable walkers were not used for much of the

time in those subjects randomized to this form of off-loading. The use of removable cast walkers made irremovable may therefore be more appropriate in the non-compliant patients.

Total contact casting is contraindicated for use in purely ischemic ulcers and osteomyelitis, due to the risk of additional complications such as ulcer deterioration due to poor arterial inflow and the difficulty in prompt detection with a nonremovable cast.

Wound closure is the ultimate aim in the treatment of DFUs, and key elements for intervention should include removal of pressure, restoration of perfusion, eradication of infection, and local wound care.

## Neuro-Ischemic Ulcers

Peripheral ischemia in conjunction with a diabetic foot ulcer is an independent risk factor for amputation. While some patients may only have mild ischemia, others can have profound vascular insufficiency which can significantly impair healing of diabetic foot lesions. More conservative debridement may be necessary using minimal sharp debridement but considering debriding agents such as honey or larval therapy. It is safe to cast neuro-ischemic ulcers as off-loading remains an essential part of management (Nabuurs-Franssen et al. 2005). However, some degree of endovascular or vascular intervention may need consideration in order to increase the potential for healing. Any foot ulcer patient with reduced or absent foot pulses or any other suspicion of ischemia warrants thorough investigation. Initially this should comprise a noninvasive assessment using Doppler ultrasound techniques. Prior to any endovascular interventions or surgical bypass, arteriography is usually indicated. Care should be taken with the use of certain contrast media as many patients with foot ulceration have renal dysfunction. All patients with significant lower extremity PVD should be seen by a vascular surgeon who would normally be a member of the diabetic foot-care team.

## Infection

Diabetic foot infections (DFIs) are the most common reason for diabetes-related hospitalization and represent a serious complication which, if not managed appropriately, can result in lower extremity amputation. Diabetic foot ulcers (DFUs) serve as a point of entry for pathogens, and approximately 60% of DFUs are already infected on initial presentation. Gram-positive cocci, especially *Staphylococcus aureus* and to a lesser degree streptococcus species or coagulase-negative staphylococci, have been the main pathogens isolated from DFIs (Lipsky et al. 2012; Citron et al. 2007). The prevalence of Gram-negative bacteria mostly including *Pseudomonas* and *Enterobacteriaceae* species is lower but increases in chronic wounds previously treated with antibiotics. Anaerobic infection must also be considered especially in neuro-ischemic ulcers.



Antibiotic-resistant organisms have become an increasing problem in the management of DFIs over recent decades with the rise of methicillin-resistant *Staphylococcus aureus* (MRSA). Multidrug-resistant (MDR) Gram-negative strains such as highly resistant pseudomonas, extended-spectrum  $\beta$ -lactamase (ESBL), and carbapenemase-producing Gram-negative bacilli are also being isolated from diabetic foot wounds (Uckay et al. 2014).

The clinical signs usually associated with a host inflammatory response to pathogens can be reduced or absent in patients with neuropathy and ischemia with approximately 50% remaining asymptomatic for infection. Some patients will demonstrate pain, warmth, erythema, raised temperature, or raised C-reactive protein (CRP), but often wound characteristics such as new onset of tenderness, prolonged healing, and wound malodor may be the only indicators of infection. Wound discharge, poor granulation tissue, and unexpectedly poor glycemic control can be indicative of infection (Lipsky et al. 2012). Tissue samples or deep wound swabs should be taken for culture and sensitivity to inform a specific antibiotic regimen as superficial cultures are too easily contaminated by colonizing bacteria.

Clinically non-infected wounds do not require antibiotics. However, foot ulcers with any suspicion of infection should be treated by appropriate antibiotics that target the likely pathogens in the wound. Whereas superficial wound swabs are often inaccurate and misleading, often only yielding contaminants, deep tissue specimens via a curettage or after aggressive debridement are those that should be sent to the microbiology laboratory. Initial antibiotic therapy should be empirical including activity against *S. aureus* and aerobic *streptococci*. Consider agents against Gram-negative organisms for patients with severe infections. Once culture and sensitivity results are available, a more specific regimen can be initiated that targets just the causative organisms. Data do not favor any particular antibiotic treatment strategy due to local resistance patterns. Limited data support the use of topical antimicrobial treatment. Intravenous vs. oral antibiotics, intravenous antibiotic administration is only indicated in severe infections as most mild to moderate infections will respond to oral antibiotics with a high bioavailability. Appropriate antibiotic treatment is essential for treating infected diabetic foot ulcers alongside sharp debridement, drainage of purulent discharge, and appropriate off-loading. Both the International Working Group on the Diabetic Foot (Peters et al. 2016) and the Infectious Diseases Society of America (Lipsky et al. 2012) have provided useful guidelines to assist in the antibiotic treatment of infected diabetic foot ulcers.

## Wound Dressings

Wound healing can be challenging in the diabetic population and is further complicated by neuropathy and/or ischemia. Specialist dressings can provide a favorable wound environment by maintaining a moist protective occlusive layer to the wound bed. A wide range of wound dressings are available despite a meager evidence base. Basic requirements for wound dressings are absorption of exudate, thermal insulation, gas permeability, and impenetrable to microorganisms. An adherent product

should not contact the wound bed itself, thus preventing removal of newly granulated tissue. Selection of the ideal dressing will depend upon the specific characteristics of the ulcer.

As the wound progresses through the stages of healing, it may be necessary to use a variety of different dressings, i.e., sloughy wounds will need a debridement agent; clean moist wounds will need absorbency properties. Products available can be divided into three broad categories, debriding, antiseptic-based, and moisture control, and are listed in Table 2.

**Table 2** Wound management products

Dressing	Description	Contraindications	Example
<i>Hydrocolloid</i>	Facilitate rehydration and autolytic debridement Dry, sloughy, necrotic wounds Promote granulation	Infected wounds Twice weekly change	Aquacel: ConvaTec Deeside, Wales, UK Comfeel: Coloplast Peterborough, UK
<i>Hydrogels</i>	Donates liquid to dry wounds and absorbs exudates Dry, sloughy wounds Autolytic debridement	Hydrogel sheets avoided in infected wounds	Intrasite gel: Smith & Nephew Wound Management, Hull, UK Iodosorb: Smith & Nephew Wound Mgt., UK
<i>Silver</i>	Antimicrobial Colonization	Sensitivity to silver	Acticoat: Smith & Nephew Wound Mgt., USA
<i>Vapor-permeable</i>	Provide a moist healing environment Mild exude	Heavily exudating wound	Tegaderm: 3 M, Reading, UK
<i>Foam dressing</i>	Primary or secondary cover Light and heavy exudates	Remove if strike-through occurs	Allevyn: Smith & Nephew Wound Mgt., Europe Lyofam: Molnlycke, Oldham, UK
<i>Odor absorbent</i>	Absorbs odor Malodorous	Silver (sensitivity)	Actisorb: Johnson & Johnson Medical Skipton, UK
<i>Larval therapy</i>	Debridement, promote granulation Heavily sloughy necrotic wounds	Increase in pain	Maggots: Zoobiotic Bridgend, Wales, UK
<i>Alginate</i>	Hemostat. Heavy exudates	Blockage. Loose fibers	Kaltostate: ConvaTec, UK
<i>Skin substitutes</i>	Living skin. Obstinate wounds	Colonized. Infected wound	Dermagraft: Smith & Nephew Medical, Europe
<i>Iodine</i>	Antibacterial Exudating wounds	Iodine (sensitivity) Renal/thyroid conditions	Iodosorb: Smith & Nephew Medical, Europe
<i>Honey</i>	Antimicrobial Sloughy necrotic wounds Autolytic debridement	Medical grade only	L-Mesitran: Aspen Medical Europe Ltd. Ashby de la Zouch, Europe

## Negative-Pressure Wound Therapy

The use of negative-pressure wound therapy (NPWT) is becoming more popular in the outpatient setting as well as in hospitalized patients. Studies have demonstrated that wounds achieve closure in a far shorter period of time than other conventional dressing regimes (Armstrong and Lavery 2005). Increased perfusion and promotion of granulation tissue formation have been reported due to cell deformation thus increasing cell mitosis. A recent systematic review confirmed that there was some evidence to support the use of NPWT in postoperative wounds (Dunville et al. 2013).

## Growth Factors and Skin Substitutes

Wound healing involves a complex interplay with a number of growth factors, one of which is platelet-derived growth factor (PDGF). There is a growing interest in the potential application of growth factors to assist in wound healing. Becaplermin is recombinant PDGF ointment, and its use has shown some slight benefit to wounds with delayed healing. Another growth factor is the granulocyte colony-stimulating factor (GCS-F) which has been reported to improve the resolution of infection in one pilot study, while another study claimed it reduced amputation rates, but further substantiation is required (Cruciani et al. 2013). Bioengineered skin (Apligraf) and human dermis (Dermagraft) are types of biologically active implants for ulcers and contain human fibroblasts that deliver growth factors to the wound. However, the evidence base for many of these expensive therapies is weak, and further large-scale randomized controlled trials are needed, which control as best as possible for the many potentially confounding variables, particularly with regard to off-loading. A recent systematic review on interventions that enhance the healing of chronic ulcers concluded that sadly, there is little published evidence to justify the use of any of these newer expensive therapies on a regular basis (Game et al. 2016).

## Hyperbaric Oxygen Therapy

Hyperbaric oxygen therapy (HBO) has been marketed as an effective adjunct in the treatment of diabetic foot ulcers, but early trials have come under close scrutiny due to the small numbers of patients enrolled and methodological and reporting inadequacies. One well-constructed, blinded randomized controlled clinical trial reported that HBO was beneficial in treating chronic neuro-ischemic infected foot ulcers (Löndahl et al. 2010). However, subsequent studies have failed to produce similar results leaving little evidence to support the efficacy of HBO in the diabetic foot, although a large multicenter trial is currently underway in the Netherlands which should provide new data (Stoekenbroek et al. 2015).

## Charcot Neuroarthropathy

Charcot neuroarthropathy (CN) is inextricably linked with distal symmetrical somatic and autonomic neuropathy, although the exact pathogenetic mechanisms are unknown. It is characterized by osseous and joint destructive changes ultimately leading to a gross alteration in foot structure and architecture (Fig. 1). Abnormalities may occur in the forefoot, midfoot, peritalar, or ankle regions with avulsion fractures affecting the posterior tuberosity of the calcaneus. Continued mobilization due to a lack of sensory awareness further compounds the osseous structural disorganization. In the latter stages of CN, a complete midfoot collapse can be seen clinically by a rocker bottom foot (Rogers et al. 2011) (Fig. 2). Hindfoot involvement is less common, but a more rapid progression in the bone destruction results in poorer outcomes. Due to the severity and sudden onset of the disease process, there is little doubt that any neuropathic patient who presents with a warm swollen foot with or without pain should be considered to have CN until proven otherwise.

The mainstay of treatment of acute CN is off-loading usually with an irremovable below-knee cast walker. There are no proven medical or pharmacological approaches other than immobilization. The timing of surgical intervention for CN is controversial due to a lack of evidence regarding whether this should be performed in the acute or sequence phase of the disease. Exostectomies and tendon transfers can offer a reduction in bony prominences, thereby reducing the risk of ulcerative episodes. There is also little evidence to show that a surgically corrected Charcot deformity functions any better than a nonsurgically corrected deformity (Fig. 3a, b). This is mainly due to the amount of bone fusions needed to acquire adequate correction (Shen and Wukich 2013).

**Fig. 1** Chronic Charcot neuroarthropathy involving the midfoot (cuneiform-metatarsal bone area). There was extensive deformity with a large plantar ulcerative lesion under the bony prominence



**Fig. 2** Chronic neuropathic foot problems with Charcot deformity and previous amputations of four toes



**Fig. 3** (a) Radiograph of a chronic Charcot foot demonstrating previous amputation of three digits, vascular calcification, and gross disruption in the cuneiform-metatarsal joints of the midfoot. (b) Radiograph showing chronic Charcot neuroarthropathic changes in the midfoot with peri-talar destruction

In addition to CN, a number of other orthopedic problems can occur in the neuropathic foot such as spontaneous fractures with associated tendo-ligamentous damage.

## Patient Education

Patient education has long been seen as a means of increasing patient understanding of their condition, thus increasing compliance and subsequently reducing complications. Guidelines by the American Diabetes Association (American Diabetes Association 2015) and International Diabetes Federation (International Diabetes Federation guidelines for type 2 diabetes) provide information for the content and delivery of patient education programs.

Comprehension of the features of peripheral neuropathy and its implications can be difficult for patients to accept, but without such acceptance, daily self-foot examination is unlikely to occur. Successful self-management requires motivation and compliance from the patient to accept a degree of responsibility for their own care; however, foot inspection can be problematic for obese individuals and those with visual impairment. Difficulties understanding the nature and relevance of neuropathy to the individual with diabetes have also been suggested as a barrier to engaging in the education process (Vileikyte 2008).

Some success with patient engagement with diabetes foot care has occurred when an objective self-monitoring tool has been provided to patients such as temperature monitoring (Lavery et al. 2007), the Neuropad plaster to indicate neuropathy (Tentolouris et al. 2008), and a simple foot pressure mat for monitoring pressure changes under the foot (van Schie et al. 1999).

The use of inappropriate footwear, both incorrect size and those without adequate cushioning, is known to play an important role in the development of ulcers in patients with neuropathy. Tight shoes commonly lead to ulceration at dorsal deformities such as bunions or between the spaces of the toes which have been crushed together. However, loose shoes can also lead to ulceration from the foot slipping inside, creating frictional force. Even simple sports trainers can reduce plantar pressures by 50% compared to leather soles.

Additionally, patients should be advised about other associated risk factors such as controlling high blood pressure, cholesterol, smoking cessation, and obesity. Not only will these measures reduce patients' risk of ulcers, but it will also lower their macrovascular complication risk.

## Multidisciplinary Team Input

The delivery of care for patients with diabetes-related foot complications has altered over recent years. Emphasis has transferred from a centralized, diabetes foot-care teams to community-based healthcare groups. Increased awareness among healthcare

professionals and a shift away from hospital-based care have resulted in major changes for the patient and care providers.

Screening for diabetes-related foot ulcers takes place at a community level with opportunities arising in a variety of different environments. The foot-care team now extends to primary care physicians, district nurses, practice-based nurses, and community-based podiatrists.

Successful management of diabetic foot complications depends upon achieving stability in all aspects of diabetes care.

Patients requiring a total package of care from a specialist diabetes foot-care team need a structured management plan in order to contend with the multiple comorbidities and complications associated with diabetes. At the minimum, a specialist diabetes foot-care team should consist of a diabetologist, specialist foot surgeon (podiatric or orthopedic surgeon), specialist diabetes nurse, podiatrists, and a vascular surgeon.

Improved outcomes, including reduced incidence of minor and major amputations, have been demonstrated in a number of studies when care is delivered in this way (Krishnan et al. 2008). One study directly compared outcomes associated with care delivered by an established multidisciplinary diabetes team (MDT) with another hospital lacking a designated diabetes team. Results showed a significant reduction in major amputations performed on patients treated by the MDT (4.7%) versus 21.7% without MDT input ( $p < 0.0001$ ). Mortality during hospitalization was also significantly different between the two groups at 2.5% for the MDT group and 9.4% for the controls (Weck et al. 2013).

## Summary

The development of diabetic foot complications involved is dependent on multiple factors primarily arising from prolonged hyperglycemia. The unprecedented global increase in type 2 diabetes is predicted to continue and in turn embed diabetic foot complications further into healthcare provision. Mortality from diabetes-related illness has decreased as a result of a variety of healthcare strategies (Jeffcoate et al. 2016), but morbidity levels also need to be addressed. The tools for reducing diabetes-related foot complications are already available to the multidisciplinary team in the form of consensus and evidence-based guidelines. Clinical effectiveness of diabetes foot care, however, can be limited by lack of patient engagement in their own care and may represent the most significant barrier to future success in the management of the diabetic foot.

---

## Conclusions

Although there has been much progress in our understanding of the etiopathogenesis and management of diabetic foot disorders over the last 30 years, much of what we use in clinical practice today still lack an evidence base. This is particularly true, for

example, for dressings. The International Working Group on the Diabetic Foot recently reported on the details required in the planning and reporting of intervention studies in the prevention and management of diabetic foot lesions (Jeffcoate et al. 2016). Details of the necessary trial design, conduct, and reporting should be taken into account when assessing published studies on interventions in the diabetic foot. Most important of all, however, in the management of patients with diabetic foot disorders is to remember that the patient has frequently lost the “gift of pain” that protects most of us from developing significant foot problems but, when absent, can lead to devastating consequences.

---

## References

- Abbott CA, Carrington AL, Ashe H, Bath S, Every LC, Griffiths J, et al. The North-West Diabetes Foot Care Study: incidence of, and risk factors for new diabetic foot ulceration in a community-based patient cohort. *Diabet Med.* 2002;19:377–84.
- American Diabetes Association. Microvascular complications and foot care. *Diabetes Care.* 2015;38:S58–66.
- Armstrong DG, Lavery LA. Diabetic Foot Study Consortium. Negative pressure wound therapy after partial diabetic foot amputation: a multicentre, randomised controlled trial. *Lancet.* 2005;366:1704–10.
- Armstrong DG, Lavery LA, Kimbriel HR, Nixon BP, Boulton AJM. Activity patterns of patients with diabetic foot ulceration: patients with active ulceration may not adhere to a standard pressure off-loading regimen. *Diabetes Care.* 2003;26:2595–7.
- Armstrong DG, Lavery LA, Wu S, Boulton AJ. Evaluation of removable and irremovable cast walkers in the healing of diabetic foot wounds: a randomised controlled trial. *Diabetes Care.* 2005;28:551–4.
- Armstrong DG, Boulton AJM, Bus SA. Diabetic Foot Ulcers and their recurrence. *N Engl J Med* 2017;376:2367–2375.
- Bakker K, Apelqvist J, Lipsky BA, Van Netten JJ, et al. The 2015 IWGDF guidance documents on prevention and management of foot problems in diabetes: development of an evidence based global consensus. *Diabetes Metab Res Rev.* 2016;32:2–6.
- Boulton AJM. Management of diabetic peripheral neuropathy. *Clin Diabetes.* 2005;23:9–15.
- Boulton AJM, Malik RA, Arezzo JL, Sosenko JM. Diabetic somatic neuropathies: technical review. *Diabetes Care.* 2004;27:1458–86.
- Boulton AJM, Vileikyte L, Ragnaaronson-Tennvall G, Apelqvist J. The global burden of diabetic foot disease. *Lancet.* 2005;366:1719–24.
- Boulton AJM, Armstrong DG, Albert SF, Frykberg RG, Hellman R, Kirkman MS, et al. Comprehensive foot examination and risk assessment. *Diabetes Care.* 2008;31:1679–85.
- Bowling FL, Abbott CA, Harris WE, et al. A pocket-sized disposable device for testing the integrity of sensation in the outpatient setting. *Diabet Med.* 2012;29:1550–2.
- Cavanagh P, Attinger C, Abbas Z, Bal A, Rojas N, Xu ZR. The cost of treating diabetic foot ulcers in 5 different countries. *Diabetes Metab Res Rev.* 2012;28:107–11.
- Citron DM, Goldstein EJ, Merriam CV, Lipsky BA, Abramson MA. Bacteriology of moderate-to-severe diabetic foot infections and in vitro activity of antimicrobial agents. *J Clin Microbiol.* 2007;45:2819–28.
- Cruciani M, Lipsky BA, Mengoli C, de Lalla F. Granulocyte-colony stimulating factors as adjunctive therapy for diabetic foot infections. *Cochrane Database Syst Rev.* 2013;10:CD006810.
- Department of Health. Six years on delivering the national service framework in diabetes. (2010). <http://nationalarchives.gov.uk>



- Diabetes UK. Cost of diabetes report. 2014. Available from <http://www.diabetes.org.uk/Documents/CostofDiabetes>
- Dunville JC, Hinchliffe RA, Cullum N, et al. Negative pressure wound therapy for treating foot wounds in people with diabetes mellitus. *Cochrane Database Syst Rev.* 2013;10:CD010318.
- Game FL, Apelqvist J, Attinger C, et al. Effectiveness of interventions to enhance healing of chronic ulcers of the foot in diabetes: a systematic review. *Diabetes Metab Res Rev.* 2016;32:154–68.
- Gonzalez JS, Vileikyte L, Ulbrecht JS, Rubin RR, Garow AP, Delgado C, Cavanagh PR, Boulton AJM, Peyrot M. Depression predicts first but not recurrent diabetic foot ulcers. *Diabetologia.* 2010;53:2241–8.
- Health and Social Care Information Centre. National Diabetes In-patient Audit 2012. 2013. <https://catalogue.ic.nhs.uk/publications/clinical/diabetes/nati-diab-inp-audi-12/nati-diab-inp-audi-12-nat-rep.pdf>
- Holman N, Young RJ, Jeffcoate WJ. Variation in the recorded incidence of amputation of the lower limb in England. *Diabetologia.* 2012;55:1919–25.
- International Diabetes Federation guidelines for type 2 diabetes. [www.idf.org/sites/default/files/IDF-Guideline-for-Type-2-Diabetes.pdf](http://www.idf.org/sites/default/files/IDF-Guideline-for-Type-2-Diabetes.pdf)
- Inzucchi SE, Bergenstal R, Buse J, Diamant M, Ferrannini E, Nauck M, Mathews D. Management of hyperglycaemia in type 2 diabetes, a patient centred approach: update to a position statement of the American Diabetes Association and the European Association for the study of diabetes. *Diabetes Care.* 2015;38:140–9.
- Jeffcoate WJ, Bus SA, Game FL, et al. Reporting standards of studies and papers on the prevention and management of foot ulcers in diabetes: required details and markers of good quality. *Lancet Diabetes Endocrinol.* 2016;4:781–8.
- Jeffcoate WJ, Young RJ. National diabetic foot audit of England and Wales yields its first dividends. *Diabet Med.* 2016;33:1464–5.
- Katz IA, Harlan A, Miranda-Palma B, Prieto-Sanchez L, et al. A randomized trial of two irremovable off-loading devices in the management of plantar neuropathic diabetic foot ulcers. *Diabetes Care.* 2005;28:555–9.
- Kerr M, Rayman G, Jeffcoate WJ. Cost of diabetic foot disease to the National Health Service in England. *Diabet Med.* 2014;(12):1498–504.
- Krishnan S, Nash F, Baker N, Fowler D, Rayman G. Reduction in diabetic amputations over 11 years in a defined UK population: benefits of multidisciplinary team work and continuous prospective audit. *Diabetes Care.* 2008;31:99–101.
- Lavery LA, Higgins KR, Lanctot DR, et al. Preventing diabetic foot ulcer recurrence in high risk patients. Use of temperature monitoring as a self-assessment tool. *Diabetes Care.* 2007;30:114–20.
- Lavery LA, Lavery DC, Hunt NA, LaFontaine J, Ndip A, Boulton AJM. Amputations and foot-related hospitalizations disproportionately affect dialysis patients. *Int Wound J.* 2015;12(5):523–6.
- Leese GP, Stang D, McKnight JA, The Scottish Diabetes Foot Action Group. A national strategic approach to diabetic foot disease in Scotland: changing a culture. *Br J Diabetes Vasc Dis.* 2011;11(2):69–73.
- Lipsky BA, Berendt AR, Cornia PB, et al. Infectious Diseases Society of America clinical practice guideline for the diagnosis and treatment of diabetic foot infections. *Clin Infect Dis.* 2012;54:e132–73.
- Löndahl M, Katzman P, Nilsson A, et al. Hyperbaric oxygen facilitates healing of chronic foot ulcers in patients with diabetes. *Diabetes Care.* 2010;33:998–1003.
- Nabuurs-Franssen MH, Slegers R, Huijberts MS, Wijnen W, Sanders AP, Walenkamp G, et al. Total contact casting of the diabetic foot in daily practice a prospective follow up study. *Diabetes Care.* 2005;28:243–7.
- National Institute for Clinical Excellence 2004. Clinical guidelines for type 2 diabetes: prevention and management of foot problems (CG10). <http://www.nice.org.uk/guidance/cg10/resources/cg10-type-2-diabetes-footcare-information-for-the-public2>

- Ndip A, Rutter MK, Vileikyte L, et al. Dialysis is an independent risk factor for foot ulceration in patients with diabetes and chronic kidney disease. *Diabetes Care*. 2010;33:1811–6.
- Oyibo S, Jude EB, Tarawneh I, Nguyen HC, Harkless LB, Boulton AJ. A comparison of two diabetic foot ulcer classification systems. *Diabetes Care*. 2001;24:84–8.
- Pecoraro RE, Reiber GE, Burgess EM. Pathways to diabetic limb amputation: basis for prevention. *Diabetes Care*. 1990;13:513–21.
- Peters EJ, Lipsky BA, Aragon-Sanchez J, et al. Interventions in the management of infection in the foot in diabetes: a systematic review. *Diabetes Metab Res Rev*. 2016;32:145–53.
- Piaggese A, Macchiarini S, Rizzo L, Palumbo F, Tedeschi A, Nobili LA, Del Prato S. An off the shelf instant contact casting device for the management of diabetic foot ulcers: a randomised prospective trial versus traditional fiberglass cast. *Diabetes Care*. 2007;30:586–90.
- Pop-Busui R, Boulton AJ, Feldman EL, Brill V, Freeman R, et al. Diabetic neuropathy: a position statement by the American Diabetes Association. *Diabetes Care*. 2017;40:136–54.
- Prompers L, Huijberts M, Scaper N, et al. Resource utilisation and costs associated with the treatment of diabetic foot ulcers. Prospective data from the Eurodiale study. *Diabetologia*. 2008;51:1826–34.
- Rayman G, Vas PR, Baker N, et al. The Ipswich Touch Test: a simple and novel method to identify in patients with diabetes at risk of foot ulceration. *Diabetes Care*. 2011;34:1517–8.
- Reiber GE, Vileikyte L, Boyko E, del Aquila M, Smith DG, Lavery LA, Boulton AJM. Causal pathways for incident lower extremity ulcers in patients with diabetes from 2 settings. *Diabetes Care*. 1999;22:157–62.
- Rogers LC, Frykberg RG, Boulton AJM. The Charcot foot in diabetes. *Diabetes Care*. 2011;34:2123–9.
- Schaper NC, Andros G, Apelqvist J, et al. Diagnosis and management of peripheral arterial disease in diabetic patients with a foot ulcer. *Diabetes Metab Res Rev*. 2012;28:218–24.
- Shen W, Wukich D. Orthopaedic surgery and the diabetic Charcot foot. *Med Clin N Amer*. 2013;97:873–82.
- Singh N, Armstrong DG, Lipsky BA. Preventing foot ulcers in patients with diabetes. *JAMA*. 2005;293:217–28.
- Skrepnek GH, Mills JL, DG A. Foot-in-wallet disease: tripped up by “cost saving” reductions? *Diabetes Care*. 2014;37:e196–7.
- Stoekenbroek RM, Santema TB, Koelemay MJ, et al. Is additional hyperbaric oxygen therapy cost-effective for treating ischemic diabetic ulcers? Protocol for the Dutch DAMOCLES multicentre randomized clinical trial. *J Diabetes*. 2015;7:125–32.
- Tentolouris N, Achtsidis V, Marinou K, Katsilambros N. Evaluation of the self-administered indicator plaster neuropad for the diagnosis of neuropathy in diabetes. *Diabetes Care*. 2008;31:236–7.
- Tentolouris N, Marinou K, Kokotis P, Karanti A, Diakoumopoulou E, Katsilambros N. Sudomotor dysfunction is associated with foot ulceration in diabetes. *Diabet Med*. 2009;26:302–5.
- The diabetes control and complications research group. Effect of intensive treatment of diabetes on the development and progression of long term complications in insulin-dependent diabetes mellitus. *N Engl J Med*. 1993;329:977–86.
- Uckay I, Gariani K, Pataky Z, Lipsky BA. Diabetic foot infections: state-of-the-art. *Diabetes Obes Metab*. 2014;16:305–16.
- Valk GD, de Sonnaville JJ, van Houtum WH, et al. The assessment of diabetic polyneuropathy in daily clinical practice: reproducibility and validity of Semmes Weinstein monofilaments examination and clinical neurological examination. *Muscle Nerve*. 1997;20:116–8.
- van Schie CH, Abbott CA, Vileikyte L, Shaw JE, Hollis S, Boulton AJM. A comparative study of the Podotrack, a simple semi-quantitative plantar pressure measuring device, and the optical paedobarograph in the assessment of pressures under the diabetic foot. *Diabet Med*. 1999;16:144–59.
- Vileikyte L. Psychosocial and behavioural aspects of diabetic foot lesions. *Curr Diab Rep*. 2008;8:119–25.

- Vileikyte L, Rubin RR, Leventhal H. Psychological aspects of diabetic neuropathic foot complications: an overview. *Diabetes Metab Res Rev.* 2004;20:13–8.
- Weck M, Slesaczek T, Paetzold H, et al. Structured healthcare for subjects with diabetic foot ulcers results in major reduction of amputation rates. *Cardiovasc Diabetol.* 2013;12:45.
- Young MJ, Breddy JL, Veves A, Boulton AJM. The prediction of diabetic neuropathic foot ulceration using vibration perception thresholds. A prospective study. *Diabetes Care.* 1994;17:557–600.



Riccardo Vigneri and Laura Sciacca

## Contents

Introduction .....	378
Diabetes-Cancer Association: Epidemiology .....	379
Diabetes and Cancer Incidence in Different Tissues .....	380
Type 1 Diabetes and Cancer .....	383
Cancer-Related Mortality and Diabetes .....	384
Mechanisms of the Cancer-Promoting Effect of Diabetes .....	386
General Mechanisms .....	387
Site-Specific Mechanisms .....	389
Mechanisms of Increased Cancer-Related Mortality in Diabetes .....	390
Antidiabetes Drugs and Cancer Risk .....	390
Insulin Analogs .....	391
Oral Antidiabetic Drugs .....	396
Cancer Drugs Causing Hyperglycemia and Insulin Resistance .....	400
Glucocorticoids .....	401
Antiandrogens and Other Hormonal Therapies .....	402
Cancer Drugs Targeting the Insulin Signaling Pathways .....	402
Approach to Hyperglycemia Induced by Cancer Treatment .....	403
References .....	404

## Abstract

Cancer incidence and mortality are higher in diabetic patients. Although epidemiological data on the diabetes-cancer association mainly concern type 2 diabetes, recent data confirm that cancer incidence is also increased in type 1.

---

R. Vigneri (✉) · L. Sciacca  
Endocrinology, Department of Clinical and Experimental Medicine, University of Catania,  
Garibaldi-Nesima Hospital, Catania, Italy  
e-mail: [vigneri@unict.it](mailto:vigneri@unict.it); [lsciacca@unict.it](mailto:lsciacca@unict.it)

The increased incidence of cancer in diabetic patients is documented for many organs (i.e., liver, pancreas, stomach, kidney, endometrium, breast) but not for all (prostate, lung).

Diabetes promotes cancer by multiple mechanisms that are both general (i.e., hyperinsulinemia and hyperglycemia) and site specific (i.e., increased hepatosteatosis and hepatitis in diabetes favor liver cancer).

Also the increased cancer mortality in diabetic patients is due to several mechanisms that, on one side, can make the cancer more aggressive and, on the other side, make the patient a fragile subject because of the frequent chronic complications of diabetes. Moreover, because of these complications, many diabetic patients receive less than optimal cancer therapy.

A matter of concern for cancer promotion is all conditions causing hyperinsulinemia, both endogenous (insulin-resistant diseases with compensatory hyperinsulinemia, like obesity and prediabetes) and exogenous. Treatments with high doses of insulin (with special attention to long-acting analogs) and with secretagogues like sulfonylureas may promote the growth of silent, subclinical tumors. In contrast, metformin, the most used first-line hypoglycemic agent, can decrease cancer risk because of its indirect effect (insulin sensitizer, reducing insulin resistance and hyperinsulinemia) and also with a direct effect, reducing cancer cell proliferation with multiple actions.

One additional problem in patients with diabetes and cancer is the hyperglycemic effect of many cancer drugs. Glucocorticoids, antiandrogens, and recent biological drugs targeting the insulin and insulin-like growth factor 1 (IGF-1) signaling pathways may cause hyperglycemia, sometimes severe. This complication can concern patients unaware of diabetes or prediabetes and may adversely affect both patient well-being and cancer progression.

In conclusion, cancer and diabetes are two very prevalent diseases and each one can negatively influence the other one. Cancer-related death accounts for approximately one-third of deaths in diabetic patients. It is important, therefore, to promote all preventive measures (often similar for the two diseases) and personalize the treatment according to the features of the diseases and the characteristics of the patient.

---

**Keywords**

Diabetes and cancer · Hyperglycemia and cancer · Insulin and cancer · Hypoglycemic agent and cancer · Cancer drugs and hyperglycemia · Insulin receptor and cancer

---

**Introduction**

Diabetes and cancer are both prevalent diseases in the industrialized world and their incidence is increasing worldwide. Epidemiological studies and meta-analyses indicate that both cancer incidence and cancer-related mortality are increased in diabetic patients, especially in type 2 diabetics (Belfiore et al. 2009).

Both diabetes and cancer are chronic diseases, each with heterogeneous etiopathogenesis and variable clinical expression which, in addition, significantly changes in a time-dependent manner.

The two diseases share many common risk factors including age, diet, smoking, alcohol, sedentary life, and obesity, and this explains a certain degree of association between the two diseases. Diabetic patients, however, have additional metabolic, hormonal, and clinical characteristics that may favor cancer incidence and cancer-related mortality.

In this chapter we will try to analyze the diabetes-cancer association in terms of epidemiology, pathogenesis, and risk factors. These elements should be considered for a rational approach to the prevention and treatment of cancer in the diabetic patient.

---

## Diabetes-Cancer Association: Epidemiology

Diabetes mellitus (DM) is a group of metabolic disorders characterized by hyperglycemia. The two most frequent subtypes of diabetes mellitus differ for both metabolic and hormonal characteristics: in type 1 diabetic patients (5–10% of all diabetics), hyperglycemia is associated with an absolute deficiency of endogenous insulin secretion and the absolute requirement for exogenous insulin administration. In type 2 diabetes mellitus (T2DM), hyperglycemia and hyperinsulinemia coexist for a long time because of the insulin resistance of peripheral tissues. Only when the  $\beta$ -cell function fails the patient will require substitute insulin treatment.

In spite of these considerable pathogenetic and clinical differences, many studies on the association between diabetes and cancer were carried out without an appropriate distinction between the two major forms of diabetes. However, since both cancer and type 2 diabetes are more prevalent in advanced age and T2DM is the most frequent type of DM (90% of all diabetic patients) for obvious epidemiological reasons, most studies on the association between cancer and diabetes have been carried out in patients with T2DM (Kido et al. 2001).

Many epidemiological studies indicate that in type 2 diabetic patients, the risk for several solid and hematologic malignancies (including liver, pancreas, colorectal, kidney, bladder, endometrial, and breast cancers and non-Hodgkin's lymphoma) is more elevated. Data on lung cancer associated with diabetes are controversial, and for prostate cancer a reduced incidence has been reported in diabetic patients (Table 1). If we accept that cancer is more frequent in diabetes, the positive association between diabetes and cancer risk might actually be somewhat underestimated since type 2 diabetes is an underdiagnosed disease (3–5% of the adult population has undiagnosed diabetes) (Harris et al. 1998). Thus, the control population very likely includes individuals with diabetes, which will apparently increase the cancer risk in the nondiabetic population.

**Table 1** Relative risk (RR) of cancer in different organs of diabetic patients

Cancer		RR (95% CI)
Endometrium (Friberg et al. 2007; Liao et al. 2014)	13 case-control studies	2.22 (1.80–2.74)
	23 cohort studies	1.61 (1.51–1.71)
Liver (Wang et al. 2012)	13 cohort studies	2.01 (1.61–2.51)
Pancreas (Ben et al. 2011)	35 cohort studies	1.94 (1.66–2.27)
Kidney (Bao et al. 2013)	7 case-control studies	1.39 (1.13–1.72)
	11 cohort studies	1.39 (1.09–1.78)
Colon-rectum (Guraya 2015)	8 cohort studies	1.21 (1.02–1.42)
Bladder (Xu et al. 2013b; Zhu et al. 2013)	6 cohort studies	1.32 (1.18–1.49)
	19 cohort studies	1.35 (1.12–1.62)
Non-Hodgkin's lymphoma (Castillo et al. 2012)	10 case-control studies	1.24 (1.03–1.49)
	11 cohort studies	1.21 (1.02–1.45)
Breast (Larsson et al. 2007; De Bruijn et al. 2013)	5 case-control studies	1.18 (1.05–1.32)
	20 cohort studies	1.23 (1.12–1.34)
Prostate (Bansal et al. 2013)	16 case-control studies	0.85 (0.74–0.96)
	29 cohort studies	0.87 (0.80–0.94)

## Diabetes and Cancer Incidence in Different Tissues

*Liver cancer.* Several meta-analyses indicate that the strongest association between diabetes and increased cancer risk concerns pancreatic and liver cancer (Table 1), i.e., two key organs involved in the metabolic derangements typical of diabetes.

Most epidemiologic studies indicate a two- to threefold increase in *hepatocellular carcinomas (HCC)* in both male and female diabetic patients (Hassan et al. 2010; Wang et al. 2012). Whether diabetes per se is a direct risk factor for liver cancer or whether diabetes-related liver diseases are mainly responsible is debated. Indeed hepatosteatosis and cirrhosis, both well-known risk factors for HCC, are more frequent in diabetic patients. Likewise, the nonalcoholic fatty liver disease (NAFLD) is very common in both diabetes and obesity and even more frequent in T2DM patients with obesity, a condition occurring in over 80% of T2DM patients. Additional factors that may favor HCC in DM include HBV and HCV infections, also more frequent in diabetic subjects as compared to the nondiabetic population, and risk factors for cirrhosis and HCC (Chen et al. 2006; Davila et al. 2005).

In conclusion, increased liver cancer incidence in diabetes is well documented although the exact mechanisms underlying this association are still unclear.

Meta-analyses indicate that diabetes is associated with an increased risk of *pancreatic cancer*, with a twofold increase relative to the control population (RRs, 1.94; 95% C.I.) (Ben et al. 2011). Most earlier studies investigating this association can be partially misleading because they did not distinguish between pre-existing diabetes (a condition possibly favoring exocrine pancreatic cancer) and new-onset diabetes in a pancreatic cancer patient, when diabetes is a possible consequence of the functional damage of the pancreas affected by a still undiagnosed cancer (Noy and Bilezikian 1994). The latter situation is frequent enough to suggest pancreatic cancer screening when hyperglycemia and diabetes appear after the age of 45–50 years in a lean subject

with no family history of diabetes (Noy and Bilezikian 1994; Chari et al. 2008; Pannala et al. 2009). Similarly, elderly subjects with new-onset diabetes have a 3-year risk of pancreatic cancer nearly eight times higher than a nondiabetic person of similar age and sex (Chari et al. 2005). Laboratory and clinical evidences suggest that diabetes caused by pancreatic cancer is due to cytokines produced by the tumor (Basso et al. 2002) rather than to functional failure of the endocrine pancreatic tissue because of cancer invasion and damage (Pannala et al. 2009). This conclusion is supported also by the observation that hyperglycemia occurs at an early stage of pancreatic cancer and is independent of tumor size and stage (Chari et al. 2008; Pannala et al. 2008).

The RR for pancreatic cancer in subjects affected by DM at least 1 year prior to the diagnosis is 2.1 (95% C.I., 1.6–2.8). The RR is similar (RR, 2.0) in patients having a 5-year history of pre-diagnosed diabetes (Everhart and Wright 1995). These data exclude the reverse causality of diabetes induced by pancreatic cancer and support the possibility that indeed diabetes is a relevant risk factor for pancreatic cancer.

Also the “prediabetes” condition is a risk factor for pancreatic cancer. A large study analyzing the association between post-load glucose levels and pancreatic tumors in 35,658 individuals reported a higher RR of this cancer with increasing glucose tolerance impairment. After adjusting for age, race, cigarette smoking, and BMI, the risk of pancreatic cancer mortality progressively increased from normal subjects to subjects with slightly altered post-load glycemia (RR, 1.65) and then to diabetic patients (RR, 2.15) (Gapstur et al. 2000).

The biological mechanisms underlying the association between diabetes and pancreatic cancer are unclear. Endogenous hyperinsulinemia has been indicated as a possible factor because exocrine pancreatic cells, which give rise to most pancreatic cancers, are exposed to very high insulin concentrations because of the common blood supply with the adjacent insulin-secreting islets (Williams and Goldfine 1985). High insulin levels could act as a tumor growth-promoting factor in many different ways (see later). This mechanism, however, does not justify the excess of pancreatic cancer in insulin-treated diabetic patients (Green and Jensen 1985) or in type 1 diabetes mellitus (T1DM) (Stevens et al. 2007) when pancreatic cells are not exposed to insulin levels higher than those of other tissues. In these studies, however, the analysis is hampered by the insufficient number of cases because of the lower prevalence of type 1 diabetes (less than 10% of all DM cases) and because of the younger patient age (pancreatic cancer is rare before age 40).

### **Other Cancers in Diabetes**

An increased frequency of malignancies in many organs other than the liver and pancreas has been reported in diabetic patients. The RR for these cancers is smaller than that of the liver and pancreas and has been ascribed to a variety of general and local mechanisms. Even if the risk increase is low, however, it is clinically relevant for many organs (i.e., breast, endometrium, and colon-rectum) that have a high prevalence of cancer in the general population.



The risk of *colorectal adenomas and carcinomas* is reported to be increased in T2DM patients in most, but not all, studies (Elwing et al. 2006; Limburg et al. 2006). The risk is increased in both women and men for both colon and rectal cancers (Larsson et al. 2005; Luo et al. 2012; Guraya 2015). In addition to hyperinsulinemia, hypothesized mechanisms include slower bowel transit time and the elevated fecal bile acid concentrations often observed in DM patients (Stadler et al. 1988; Will et al. 1998).

The risk of cancer in *female reproductive organs* is also increased in DM patients. Both breast and endometrial cancers are more frequent in diabetic women, and this risk is independent from obesity (a well-established factor promoting breast cancer) as it persists after correcting epidemiological data for this disease.

Several biological mechanisms may be involved, mostly regarding sex hormone abnormalities. Hyperinsulinemia may increase the levels of bioactive estrogens by decreasing the concentration of circulating sex hormone-binding globulin and might also stimulate androgen synthesis in the ovarian stroma (Kaaks 1996). Other possible mechanisms include delayed menarche, especially in type 1 diabetic women, who also have a higher incidence of irregular menses and fertility disorders.

In diabetic patients the increased incidence and increased mortality for *kidney cancer* have been attributed to both general mechanisms (hyperinsulinemia, obesity) and to specific factors, mainly hypertension (Chow et al. 2000; Yuan et al. 1998; Zucchetto et al. 2007) and the frequent kidney diseases occurring in diabetic patients (Lindblad and Adami 2002).

Individuals with DM also display a modest increase in the risk of *bladder cancer*. For this tumor, the increased frequency of urinary tract infections is a likely site-specific factor promoting this cancer in diabetic patients.

Large prospective cohort studies and case-control studies have shown a moderate increase of *non-Hodgkin's lymphoma* in diabetic patients, a possible consequence of the immune dysfunction related to impaired neutrophil activity and abnormalities in cellular and humoral immunity in diabetes (Mitri et al. 2008).

Data on the association between diabetes and *lung cancer* are inconsistent. This inconsistency is probably due to the variable influence of confounding factors (primarily smoking) that may occur differently in diabetic versus nondiabetic individuals. A meta-analysis of observational studies (10 case-control studies and 24 cohort studies) found that diabetes was significantly associated with the increased risk of lung cancer compared with nondiabetic controls when limiting the analysis to studies in which data were adjusted for the patient smoking status (RR 1.11, 95% C.I., 1.02–1.20). By contrast, this association disappeared when only series not adjusted for the smoking status were considered, probably because cigarette smoking is less prevalent in diabetic patients (RR 0.99, 95% C.I., 0.88–1.11). When stratifying by sex, an increased risk of lung cancer was significant in diabetic women (RR 1.14, 95% C.I., 1.09–1.20) but not in diabetic men (Lee et al. 2013).

In contrast to the increased risk for most cancers, a reduced risk of *prostate cancer* is found in many studies in men with diabetes. A meta-analysis (Kasper and Giovannucci 2006) including both the 14 studies carried out in the pre-PSA era

(Bonovas et al. 2004) and also 5 additional studies carried out in the PSA era (and including, therefore, earlier diagnosed and smaller cancers) found a significantly reduced risk of prostate cancer in diabetic patients. A comprehensive review of studies on the association between DM and prostate cancer suggested an inverse relationship between DM and prostate cancers of different stage or grade (Xu et al. 2013a). The moderately (average ~15%) decreased risk of developing prostate cancer in diabetic patients has been attributed to their decreased testosterone levels (Barrett-Connor 1992; Betancourt-Albrecht and Cunningham 2003). However, other metabolic and hormonal factors, the diffuse use of medications like statins and metformin, and the changes in diet and lifestyle in order to control diabetes have also been hypothesized as possible factors contributing to the inverse association between diabetes and prostate cancer (Kasper and Giovannucci 2006).

## Type 1 Diabetes and Cancer

T1DM patients, unlike patients with T2DM, do not have a long-lasting history of endogenous hyperinsulinemia and insulin resistance. Moreover, T1DM is less frequently associated with obesity and may have either hypoinsulinemia or hyperinsulinemia of exogenous origin without the liver-periphery gradient. It is questionable, therefore, whether data obtained in T2DM patients can be automatically extended to type 1 diabetic patients. This concern is particularly relevant for the older reports in which the distinction between type 1 and type 2 diabetes was mostly based on surrogate indicators, like patient young age or insulin treatment (assumed as type 1 in all cases) versus insulin-independent diabetes (assumed as type 2). This distinction does not take into account many specific conditions, including type 2 diabetic patients that are treated with insulin because of secondary failure to oral hypoglycemic agents (OHA) and other less frequent conditions.

Thus, if cancer association with type 1 diabetes has specific characteristics, most likely these have been obscured by the large majority of cancers diagnosed in type 2 diabetic patients. Even the few studies specifically addressing cancer incidence in type 1 diabetic patients suffer from the poor assessment of the diabetes type. A Swedish study evaluating cancer incidence in nearly 30,000 T1DM patients found an increased risk for stomach, endometrial, and cervical cancer (Zendejdel et al. 2003). These positive associations have been attributed to the high prevalence of *Helicobacter pylori* infection or of pernicious anemia (for gastric carcinomas) (De Block et al. 1999; Oldenburg et al. 1996) and to the higher incidence of irregular menses and fertility disorders in type 1 diabetic women (for uterine malignancies). At variance with type 2 diabetic patients, no increased risk of breast, pancreatic, colorectal, or kidney cancer was found in that cohort. In contrast with this report, a meta-analysis including three cohort studies and six case-control studies found that the risk for pancreatic cancer was doubled in type 1 and in young-onset diabetic patients in comparison with nondiabetic subjects (Stevens et al. 2007). A recent study resolving five nationwide diabetes registers and 9,149 cancers in T1DM patients found that the overall HR for cancer was 1.01 among T1DM male and

**Table 2** Hazard ratios (HR) of different cancers in type 1 diabetic patients. (From Carstensen et al. 2016)

Cancer	Men HR (95% C.I.)	Women HR (95% C.I.)
All	1.01 (0.58–1.04)	1.07 (1.04–1.10)
Liver	2.0 (1.67–2.40)	1.55 (1.14–2.10)
Pancreas	1.53 (1.30–1.79)	1.25 (1.02–1.53)
Stomach	1.23 (1.04–1.46)	1.78 (1.49–2.13)
Kidney	1.30 (1.12–1.49)	1.47 (1.23–1.77)
Endometrium	=	1.42 (1.27–1.58)
Breast	=	0.90 (0.85–0.94)
Prostate	0.56 (0.51–0.61)	=

1.07 among T1DM female patients. The risk of several cancers, however, was significantly increased in T1DM patients (Table 2), resembling data found in T2DM patients except for breast cancer whose HR was reduced in T1DM. Therefore, both type 1 and type 2 diabetes are associated with an excess risk for a number of site-specific cancers as pancreas, liver, kidney, and endometrium cancer (Carstensen et al. 2016; Harding et al. 2015).

## Cancer-Related Mortality and Diabetes

Data on cancer mortality in diabetic patients are less abundant and less homogeneous than data on cancer incidence.

The hazard ratio for death in cancer patients with diabetes was estimated at 1.41 (95% C.I. 1.28–1.55) in respect to cancer patients without diabetes (Barone et al. 2008). Mortality was significantly increased for cancers of the breast, endometrium, colon, and rectum, while it was not significantly increased for lung, gastric, liver, pancreatic, and prostate cancers. However, the heterogeneity of the studies analyzed and the length of the observation period (1969–2008, 40 years during which treatment for both cancer and diabetes changed markedly) hamper, at least in part, the significance of these results. The analysis of the cause of death in 820,900 people in 97 studies, after adjusting for age, sex, smoking, and body mass index, found that in diabetic patients, the hazard ratio for death from cancer was 1.25 (95%, C.I. 1.19–1.31) relative to the nondiabetic subjects. In the same studied cohorts, the hazard ratio of death for vascular diseases in diabetic patients was 2.32 (2.11–2.56) (Bansal et al. 2013).

Mortality data regarding different cancers in diabetic patients are variable but always indicate an increased risk of mortality.

A positive association between *breast cancer mortality* and diabetes was found in three out of five studies, with a RR from the pooled data of the five studies of 1.24 (95% C.I., 0.95–1.62) (Larsson et al. 2007). In the largest study (cohort size 588,321 with 4,346 deaths for breast cancer), after adjusting for age, race, BMI, physical activity, smoking, and alcohol, cancer-related death in diabetic women was 1.27

(1.11–1.45) in comparison with the nondiabetic female population. In a recent systematic review and meta-analysis, the increase of breast cancer-related mortality was 1.38 in patients with DM (De Bruijn et al. 2013). A similar value (hazard ratio in diabetic women 1.39) was found in a study evaluating mortality for breast cancer after a 5-year mean follow-up, suggesting that also early survival is reduced in women with diabetes and breast cancer (Lipscombe et al. 2008). This reduced survival might be the consequence of more aggressive breast cancer but also of diabetes-related comorbidities.

Diabetes was also positively associated with *colorectal cancer mortality*. A study aimed at evaluating the influence of diabetes on the long-term outcome of patients resected for colon cancer (3,759 patients, 287 with DM) found that diabetes negatively affected survival in colon cancer patients (Meyerhardt et al. 2003). Data were adjusted for predictors of colon cancer outcome (age, gender, race, clinical status, TNM class, Dukes stage, location of primary tumor, and grade of differentiation) and indicated that both disease-free survival (DFS) and overall survival (OS) at 5 years were significantly reduced in diabetic patients. A statistically significant association between diabetes and colorectal cancer-related death was found in three out of six studies (Larsson et al. 2005), and a not significant positive association was reported in a fourth one. Pooled data from the six studies indicated a positive association between diabetes and colorectal cancer mortality (RR, 1.26; 95% C.I., 1.05–1.50), but heterogeneity issues may partially invalidate the significance of these results. In a more recent systematic review and meta-analysis, the overall HR for colorectal cancer-specific mortality was 1.30 in patients with DM compared with subjects without diabetes (De Bruijn et al. 2013).

For other cancers available data are not sufficient to establish an association between cancer-related death and diabetes. For instance, a positive association was found between diabetes and *endometrial cancer mortality* in two studies, but it was significant only in one of them (RR, 2.38; 95% C.I., 1.05–5.37) (Coughlin et al. 2004; Folsom et al. 2004), and in a recent meta-analysis, diabetes was not positively associated with endometrial cancer mortality (Zhang et al. 2013). It is interesting to note that, although diabetic patients have a reduced risk for *prostate cancer*, once an insulin-resistant and overweight man has been diagnosed with prostate cancer, his likelihood of dying to the disease is increased in respect to nondiabetic individuals (Ma et al. 2008).

Several possible mechanisms can explain the increased risk of cancer-related death in DM. It is still unclear whether diabetes, through a number of mechanisms (see later), can make the cancer more aggressive or whether the host organism (the diabetic individual) is less resistant to cancer progression. It is also possible that diabetic patients receive reduced/insufficient cancer treatment. Oncologists may employ lower chemotherapy doses in diabetic patients, concerned about their general health condition and the possible damage of heart, liver, and kidney function caused by diabetes. The less than optimal dosage of chemotherapy might contribute to the increased cancer-related mortality observed in diabetic patients.

## Mechanisms of the Cancer-Promoting Effect of Diabetes

The reasons why cancer incidence and mortality are increased in diabetic patients are complex and not yet fully understood.

One preliminary, unresolved question is whether diabetes favors cancer initiation or cancer progression or both.

Diabetes could activate carcinogenic mechanisms that will facilitate the malignant transformation of cells resulting in an increased number of new cancers. The increased incidence of cancer in diabetic patients, however, may be apparent, due to the effect of diabetes on the progression of clinically silent cancers that will grow faster and become more aggressive and clinically relevant because of the abnormal metabolic environment and the general fragility of the diabetic patient.

An apparent increase of cancer incidence is also possible because of the increased detection of subclinical cancers in patients that usually undergo more frequent medical controls. This possibility, however, is unlikely to significantly contribute to the increased incidence of cancer because also cancer-related mortality is increased in diabetic patients.

Because of the high heterogeneity of both diabetes and cancer in terms of molecular abnormalities, etiopathogenetic sequences, involved organs, and also patient characteristics (including individual lifestyle, accompanying morbidities, and treatments), the association between diabetes and increased cancer incidence may be favored by a series of heterogeneous mechanisms in different individuals. In such a complex and multifactorial system, it is difficult to quantify the role of a single factor or mechanism that may favor cancer in diabetic patients. The involved mechanisms are not only multiple but most likely different in different patients and for different cancers.

For the sake of clarity, we can identify two major categories of mechanisms (Table 3):

**Table 3** Pathogenetic mechanisms influencing cancer incidence in diabetic patients

<i>General mechanisms</i>
• Hyperglycemia
• Hyperinsulinemia
• Inflammation
• Reduced immunological response
• Antidiabetic drugs
• Obesity
<i>Site-specific mechanisms</i>
• Liver: hepatosteatosis-viral hepatitis
• Kidney and urinary tract: infections
• Breast and endometrium: less pregnancies, delayed menarche, hormone abnormalities (obesity)
• Colon-rectum: slow bowel transit
• Prostate (reduced): reduced androgens
• Lung (not increased): reduced smoking

- (a) General mechanisms that promote cancer because typical of the diabetic condition (i.e., hyperglycemia and hyperinsulinemia and also inflammation cytokines)
- (b) Site-specific mechanisms regarding single organs and tissues whose structure and function may be altered in the diabetic patient, producing a condition that will promote cancer in specific organs

## General Mechanisms

Hyperglycemia and hyperinsulinemia, two conditions present in most diabetic patients, are believed to be the major general mechanisms that increase the risk of malignant transformation or that will promote the growth of malignantly transformed cells in diabetic individuals. Most diabetic patients, in fact, have type 2 diabetes characterized by hyperglycemia, hyperinsulinemia, and obesity, abnormalities that often are already present many years before diabetes is diagnosed. Because of the simultaneous presence of the increased levels of both glucose and insulin, it is difficult to dissect the specific role of each one in increasing cancer risk. Probably both contribute in different but synergic ways.

Hyperglycemia favors cancer because malignant cells have an altered metabolism due to mitochondrion and enzymatic abnormalities: in contrast to normal cells, to generate the energy needed for cellular processes and growth, cancer cells mainly rely on aerobic glycolysis, a phenomenon termed “the Warburg effect” (Warburg 1956). The aerobic glycolytic pathway will generate less energy in terms of adenosine 5'-triphosphate production, and therefore, from a given amount of glucose, cancer cells will obtain less energy than normal cells. To satisfy the energy requirement (higher than normal not only for the altered metabolism but also because of the increased proliferation rate), glucose is processed much faster in malignant cells and its requirement is increased. The increased glucose transport in these cells is associated with an increased and deregulated expression of the cell membrane glucose transporter proteins, mainly with overexpression of Glut-1 (Macheda et al. 2005).

The correlation between glycemic control and cancer risk is supported by the observation that both the fasting glucose and the HbA1c increase are associated with an increased risk of cancer (Yang et al. 2010; Muti et al. 2002; Shin et al. 2014) and its unfavorable outcome (Yang et al. 2016).

Many epidemiological studies, *in vitro* experiments, and clinical evidences (including the increased uptake of 2-deoxy-2-[<sup>18</sup>F] fluoro-D-glucose by tumors evidenced by positron-emission tomography – PET) document the importance of glucose availability for cancer cell biology. Hyperglycemia assures the availability of this nutrient to cancer cells. The statement “sugar fuels cancer” emphasizes this primary metabolic requirement in a deregulated system with accelerated growth.

The other major factor that may promote cancer in diabetic patients is the increased circulating insulin. Compensatory hyperinsulinemia is typical of type 2 diabetes, but also T1DM patients are often hyperinsulinemic because of the abnormal distribution of subcutaneously injected insulin in comparison with pancreas-secreted endogenous insulin. While endogenous insulin through the portal system

first goes to the liver where it is in part degraded, subcutaneously injected insulin loses the liver-periphery gradient: to have sufficient insulin at liver level, peripheral tissues will be exposed to hyperinsulinemia.

Insulin does not play a major role for glucose utilization in malignant cells because these cells overexpress Glut-1 and are mostly insulin-independent for their uptake of glucose. Insulin, however, in addition to being a metabolic hormone, is also a growth factor with mitogenic effects via activation of the mitogen-activated protein (MAP) kinase intracellular pathway and the mTOR signaling (Kido et al. 2001; Dibble and Cantley 2015), and hyperinsulinemia can favor cancer by promoting its growth. This effect of insulin can be exerted via its own receptor but also by activating the cognate insulin-like growth factor-1 receptor (IGF-1R) receptor that has a potent mitogen and transforming potential and that will cross-react with insulin when the increased concentration of the ligand will overcome the reduced IGF-1R-insulin affinity. These effects may occur in diabetic patients because of their hyperinsulinemia, both endogenous (secondary to insulin resistance) and also exogenous (due to high-dose insulin treatment). This has raised some concerns regarding the possible cancer risk associated with insulin administration, especially with long-acting analogs (vide infra).

The growth-promoting effect of hyperinsulinemia is increased in cancer cells because of two independent mechanisms related to the insulin receptor biology in cancer cells (Table 4). First, most cancer cells overexpress the insulin receptor and, therefore, are more responsive than normal cells to the mitogenic effect of insulin (Papa et al. 1990; Vella et al. 2001).

Second, dedifferentiation makes cancer cells similar to fetal cells in terms of insulin receptor isoform prevalence. As in fetal cells, also in cancer cells the alternative splicing of the IR transcript will favor the exon 11-isoform A of the insulin receptor protein (IR-A) (Frasca et al. 1999, 2008; Sciacca et al. 2013). The IR-A isoform, compared with the B isoform, has a more pronounced mitogenic rather than metabolic effect and will make cancer cell proliferation especially responsive to hyperinsulinemia (Belfiore et al. 2009; Frasca et al. 1999). Moreover, IR-A is a high-affinity receptor for IGF-2 (Fig. 1) and locally (autocrine/paracrine) produced IGF-2 will further stimulate cancer growth via the overexpressed IR-A (Frasca et al. 1999; Sciacca et al. 1999; Vella et al. 2002; Kalli et al. 2002).

In addition to the pro-cancer effect of increased glucose and insulin, diabetes may activate additional general mechanisms promoting cancer. Among them a major role is probably played by the chronic pro-inflammatory state, with overproduction of pro-tumoral cytokines like TNF- $\alpha$  (Kern et al. 2001; Szlosarek et al. 2006). Moreover, the increased concentrations of free radicals due to inflammation and the decrease of intracellular antioxidant capacity can damage cell DNA or interfere

**Table 4** The insulin-receptor role in favoring cancer progression

The insulin receptors (IRs) are overexpressed in many cancers
The IR isoform A (IR-A with predominant mitogenic activity) is the prevalent IR isoform in many cancers
IR-A is a high-affinity receptor for IGF-2 produced by the tumor at autocrine/paracrine level

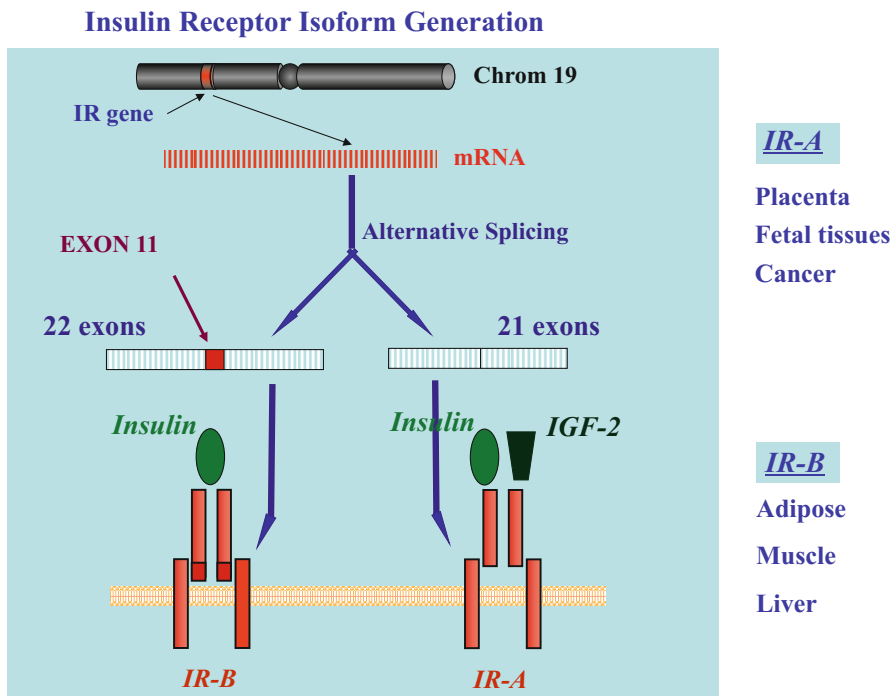

**Fig. 1** Insulin receptor isoforms. The insulin receptor gene on chromosome 19 gives origin to a 22-exon mRNA transcript that during maturation may either include or not include exon 11. This alternative splicing produces two isoforms of the insulin receptor, IR-A and IR-B, differing for 12 amino acids at the COOH terminal of the  $\alpha$ -subunit. This difference causes different binding characteristics and post-receptor signaling: the shorter isoform (IR-A) binds with high affinity not only insulin but also IGF-2 and has more mitogenic effects. IR-A is predominantly expressed in fetal tissues and in cancer cells. In contrast, IR-B has more metabolic effects and is the predominant isoform of insulin receptor in insulin target tissues (liver, muscle, and adipose tissue)

with the mechanisms of DNA repair, two processes that can contribute to the multistage sequence of carcinogenesis.

Another general mechanism causing an increased cancer risk in diabetic patients is overweight/obesity which affects over 80% of type 2 diabetic patients and is a well-recognized risk factor for cancer incidence and mortality (Aiello et al. 2006; Calle et al. 2003). In obese individuals the pro-inflammatory condition and the increased levels of leptin, an adipocyte-derived cytokine, can also promote cancer cell proliferation (Garofalo and Surmacz 2006; Barone et al. 2012).

### Site-Specific Mechanisms

In addition to the general, not organ-specific mechanisms, different organ-related mechanisms may contribute to the increased cancer incidence and mortality in



diabetic patients. Most of these mechanisms have already been described when discussing cancer incidence in diabetic patients (*vide supra*).

Diabetes can damage the structure and function of specific organs favoring site-specific risk factors for cancer. A typical example is cancer of the liver, the most prevalent cancer in diabetic patients (two- to threefold increase) (El-Serag et al. 2006). As already mentioned, the diabetes-related diseases of the liver, like steatohepatitis and cirrhosis and also hepatitis B and C viral infections, are all well-known risk factors for hepatocellular cancer and are more frequent in diabetic patients.

Another organ-specific mechanism is the abnormal steroid metabolism due to obesity that often accompanies type 2 diabetes. The obese women with diabetes have increased estrogen levels because of the augmented aromatase activity of the adipose tissue. Higher levels of estrogens, in turn, will favor estrogen-dependent cancers.

## **Mechanisms of Increased Cancer-Related Mortality in Diabetes**

The reasons and mechanisms for the increased cancer-related mortality in diabetic patients are less studied but more intuitive than those responsible for the increased cancer incidence.

First, an increased number of cancers and/or more aggressive cancers due to the already mentioned reasons will per se explain an increased mortality. Second, the general conditions typical of diabetes (hyperglycemia, hyperinsulinemia, inflammation) and of most cancer cells (overexpressing insulin receptors and mainly the A isoform) will favor cancer progression. Third, the diabetic patient is a fragile patient, often with multiple organ pathologies and under multiple drug treatment. The patient fragility will not only increase per se the death risk but will also induce oncologists to treat with a reduced anticancer dosage, especially when heart, liver, or kidney functions are defective. These reasons, often combined, can easily explain the increased cancer-related death rate in the diabetic patients (Bansal et al. 2013).

In conclusion, the mechanisms for the increased cancer incidence and mortality in diabetes, although still not fully clear, are certainly multiple, often associated or interrelated. Their relevance may differ in different diabetic patients because they will predominantly depend on the single-patient characteristics, including the genetic and environmental factors (i.e., associated diseases and treatments) involved in diabetes and in the different types of cancer.

For this reason the approach to the diabetic patient at risk of cancer or with an already diagnosed cancer will have to consider this heterogeneity and provide a personalized intervention with individually appropriate diagnostic and therapeutic procedures.

---

## **Antidiabetes Drugs and Cancer Risk**

Many studies have investigated the possible effects of antidiabetic drugs on cancer incidence and mortality, but data evaluating whether a specific antidiabetes drug use is causally related to cancer are often inconclusive or difficult to interpret.

The reason for this uncertainty is the complexity of the pharmacological treatment in diabetic patients, with the possibility of drug-drug interactions. Moreover, the changes in the treatment that often occur in a chronic disease lasting many years (decades) will also be a confounding factor.

Cigarette smoking, a well-recognized strong carcinogen, will take two or three decades before causing cancer. No antidiabetic drug can be considered a strong carcinogen (like in cigarette smoking) because this eventuality is excluded by the required tests carried out before commercialization. A possible pro-cancer effect of antidiabetes drugs on the multistep carcinogenic process will, therefore, take a long time. Available clinical studies, in contrast, have short (less than a decade) duration and are biased by the changes in dosage, patient conditions, and other drug interferences that may have occurred during the study period.

This comment is valid both for studies investigating a pro-cancer effect of an antidiabetic agent and also for studies excluding this effect.

## **Insulin Analogs**

As already mentioned, insulin is a growth factor acting via its own receptor and, when at higher concentration, also via the cognate IGF-1 receptor. Therefore, when at increased concentration because of endogenous hyperinsulinemia or high-dose exogenous insulin administration, insulin can promote cancer growth.

In the last two decades, diabetic patients are treated more frequently with insulin analogs instead of human native or recombinant insulin because insulin analogs have a pharmacokinetics that can better mimic the endogenous insulin secretion and improve glycemic control without increasing hypoglycemic events.

By recombinant technology and site-directed mutagenesis, the insulin molecule has been modified to either shorten (short-acting analogs, insulin aspart, insulin glulisine, and insulin lispro) or prolong (long-acting analogs insulin glargine, insulin detemir, insulin degludec) its action time. Molecular modifications, however, may change the analog interaction with the insulin receptor (IR), in terms of residence time of the ligand on the IR and post-receptor activation of intracellular pathways. Also the binding affinity to IGF-1R can be modified. Therefore a major question is whether insulin analogs, as a result of an imbalanced metabolic versus mitogenic effect, can favor cancer more than native insulin.

## **In Vitro Experimental Evidences**

Since the molecular structure modifications can change the insulin analog affinity for the IR, the IGF-1R, and their intracellular signaling and biological effects, their clinical use has been approved only after the assessment of their mitogenic effect (growth-promoting activity) in benign and malignant cells *in vitro*.

Malignant cells can respond to insulin and its analogs differently than normal cells because they predominantly express the IR isoform A that has more pronounced mitogenic activity. Moreover, different cancer cells express the insulin receptor and its isoforms at a different level. The studies aimed at investigating how insulin analogs bind and stimulate each IR isoform are difficult because the

large majority of cells express both IR isoforms and no direct measurement of the isoforms of the IR protein is available. To overcome this problem, some studies have been carried out in either engineered cell models expressing only one IR isoform (either only the IR-A or the IR-B) (Sciacca et al. 2010; Sommerfeld et al. 2010) or in malignant cells that naturally express predominantly one IR isoform. These models are not optimal because transfected receptors are often highly overexpressed and cells have a variable genetic background that may interfere. In these models overall data indicate that short-acting insulin analogs bind to both IR isoforms with an affinity similar to that of native insulin or only slightly different. In contrast, long-acting analogs (glargine and detemir, because degludec insulin has been only recently introduced) have a reduced affinity for both IR isoforms (Sciacca et al. 2010; Sommerfeld et al. 2010; Kurtzhals et al. 2000; Markussen et al. 1996).

Few studies have also measured the insulin analogs' dissociation from the two IR isoforms, an important parameter since the activation of post-receptor pathways also depends on the ligand residency time on the receptor. Although data are scarce and not fully comparable because of the different experimental conditions, in general the short-acting analogs' dissociation from the IR appears similar to that of native insulin, while the long-acting analogs have a slower dissociation rate (about 1.5–3.0 times longer) both when using cell models and solubilized receptors.

When analogs were studied in the same cell model, both short-acting and long-acting insulin analogs activated the phosphorylation of IR isoforms in a similar manner to human insulin (Sciacca et al. 2010; Sommerfeld et al. 2010). However, in spite of similar IR phosphorylation, differences between insulin and insulin analogs were present at downstream post-receptor level. Only subtle differences were observed for short-acting analogs for the stimulation of AKT (a marker of the metabolic signaling pathway) and ERK phosphorylation (a marker of the mitogenic signaling pathway). More relevant differences in comparison with insulin were observed for long-acting analogs. Via the IR-A isoform, both detemir and glargine activated AKT similarly to insulin but ERK significantly more than insulin. Via the IR-B isoform, both long-acting analogs activated AKT less than insulin but ERK similarly to insulin. In both cases the result was an abnormal ERK/AKT activation ratio, clearly shifted in favor of ERK (Sciacca et al. 2010; Vigneri et al. 2010) (Fig. 2).

The data regarding the insulin stimulation of the IGF-1 receptor (IGF-1R) are somewhat controversial. Since the cancer risk associated with the IGF-1R activation is well recognized (Furstenberger and Senn 2002; LeRoith and Roberts 2003; Renehan et al. 2004; LeRoith and Yakar 2007), it is a serious concern the possibility that the modified molecular structure of insulin analogs may cause an increased affinity for the IGF-1R. If this is the case, in fact, the mitogenic potential of the analogs could be increased in respect to insulin.

Different cell models and different experimental protocols were used to measure analogs' affinity for the IGF-1R overcoming the difficulties due to the interference of the IR present in the cell. The most cited study by Kurtzhals et al. (in the Novo Laboratories) indicated that lispro has a slightly higher affinity for the IGF-1R in comparison to insulin (Kurtzhals et al. 2000), while aspart insulin bound IGF-1R less

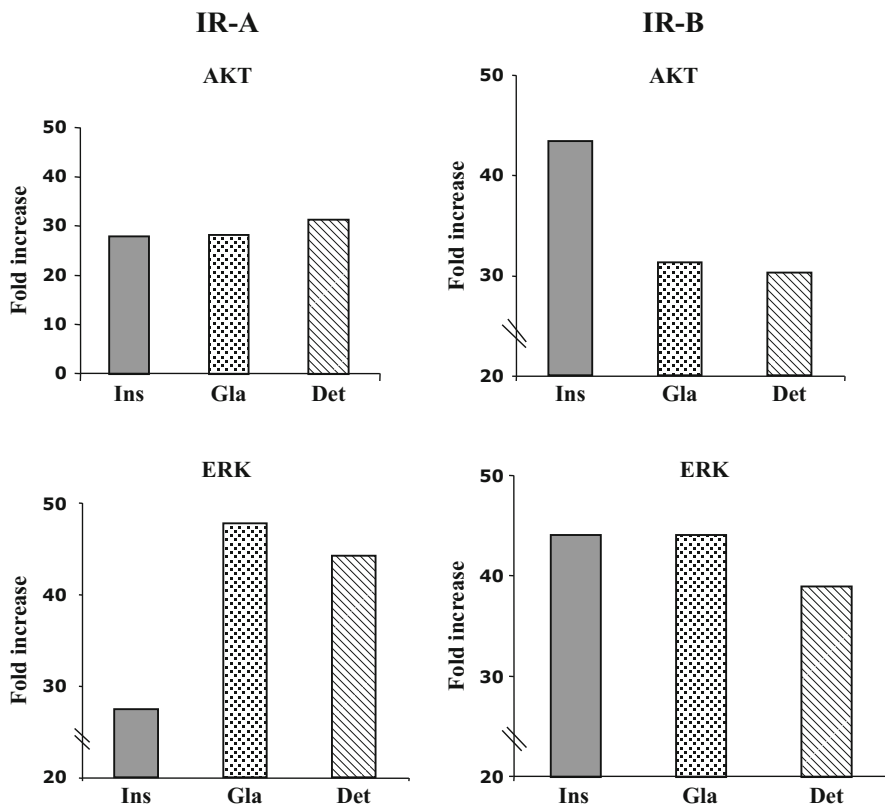

**Fig. 2** Post-receptor pathway activation by long-acting insulin analogs. In engineered cells expressing only the IR-A isoform (left panel), the effects of insulin and long-acting analogs glargine and detemir are not different on post-receptor intracellular AKT pathway (mainly metabolic). In contrast, both long-acting analogs cause a markedly increased stimulation of the ERK pathway (mainly mitogenic) in comparison with insulin. In cells expressing only the IR-B isoform (right panel), the effect of the three ligands is similar on the ERK pathway, but the two long-acting analogs have a reduced effect on the AKT pathway. Therefore, long-acting analogs cause an increase of the ERK/AKT activation ratio in comparison with native insulin both in cells expressing only IR-A as well as in IR-B cells. The columns indicate the fold increase (area under the curve) of the phosphorylated effectors in the period 0–10 min of exposure to ligands (Vigneri et al. 2010)

than insulin (Kurtzhals et al. 2000). In an engineered cell model expressing only the human IGF-1R, the three short-acting analogs bound to IGF-1 receptor similarly to native insulin (Sciacca et al. 2010).

In vitro data demonstrated that the long-acting insulin glargine binds to the IGF-1R with a higher affinity than insulin, and some studies attributed to the increased IGF-1R activation the increased mitogenic effect of this analog (Kurtzhals et al. 2000). After glargine injection in patients, however, the proteolytic degradation of glargine produces two active metabolites, M1 and M2, which apparently have

reduced IGF-1R affinity and reduced mitogenic potency relative to insulin (Sommerfeld et al. 2010; Sciacca et al. 2014).

The other long-acting insulin analog, detemir, has been studied much less than glargine. The interaction of this analog with IGF-1R was calculated to be very low, approximately on sixth that of human insulin by Kurtzhals et al. (2000). But in a different model (engineered cells overexpressing IGF-1R and avoiding albumin interference), the two long-acting insulin analogs (detemir and glargine) showed a very similar IGF-1R binding affinity, higher than that of human insulin (Sciacca et al. 2010).

Insulin degludec has been only recently introduced, and, at present, the information on this analog interaction and activation of receptors is limited. Preliminary data indicate that its binding to the IR is similar to that of insulin and that binding to the IGF-1R is lower than the native hormone (Nasrallah and Reynolds 2012).

No data are available on insulin analogs' interactions with hybrid (IR/IGF-1R) receptors and on their post-receptor signaling after hybrid receptor activation.

The growth-promoting effect of insulin analogs was also studied directly in malignant cells. Also these models are only partially satisfactory. The growth rate is remarkably heterogeneous in different malignant cells, and very few studies have compared the proliferative effect of all insulin analogs in the same cell model. Moreover, the mitogenic effect of the analogs has been usually evaluated at concentrations higher than levels in the blood of treated patients (50–100 nM). In general, short-acting analogs stimulated cancer cell proliferation in a similar manner to human insulin (Kurtzhals et al. 2000; Sciacca et al. 2014; Mayer et al. 2008; Shukla et al. 2009; Weinstein et al. 2009), while long-acting analogs stimulated proliferation more than insulin. Although data are not homogeneous, in a variety of cell models, both glargine and detemir caused an increased mitogenic response (Sommerfeld et al. 2010; Kurtzhals et al. 2000; Sciacca et al. 2014). The proliferation of cancer cells was stimulated by these long-acting insulin analogs more than insulin but less than IGF-1 (Sciacca et al. 2014; Weinstein et al. 2009). However, when insulin glargine metabolites M1 and M2 were evaluated, their mitogenic effect was similar to that of human insulin (Sommerfeld et al. 2010; Sciacca et al. 2014).

For the clinical implications, it is remarkable to underline that the biological responses to insulin analogs of cancer cells expressing different levels of the IR and different prevalence of the isoforms IR-A and IR-B and of IGF-1R cannot be predicted on the basis of receptor expression levels (Sciacca et al. 2014). The cell proliferation, invasiveness, and foci formation responses to the analogs are not correlated to the malignant cell receptor content, implying that different factors other than IR expression influence these parameters.

### **Clinical Studies on Insulin Analogs and Cancer**

In 2009 five retrospective observational studies using different diabetes registries were published and raised the issue of the possible increased cancer incidence in diabetic patients treated with insulin analogs (Hemkens et al. 2009; Jonasson et al. 2009; Colhoun 2009; Currie et al. 2009; Dejgaard et al. 2009). In these studies confounding factors and methodological flaws made the results interpretation

questionable and controversial. Nevertheless great concern was raised whether insulin analogs (and mainly insulin glargine) could promote cancer cell proliferation and tumor growth in diabetic patients.

The first retrospective cohort study included more than 127,000 patients treated in Germany with either human insulin, lispro, aspart, or insulin glargine for a mean follow-up time of 1.63 years: a dose-dependent association was found between all insulin analogs and cancer incidence, but, after adjusting for the administered dose, only glargine was related to an increased cancer risk (HR 1.31 for 50 IU daily dose compared to human insulin) (Hemkens et al. 2009).

In the same journal, data from two additional retrospective observational studies, carried out in Sweden and Scotland, were published (Jonasson et al. 2009; Colhoun 2009).

In the Swedish cohort almost 115,000 patients treated with insulin were examined, and only the risk of developing breast cancer was increased among women receiving insulin glargine in monotherapy (RR 1.99, 95% C.I., 1.31–3.03). Other forms of cancer were not increased with insulin glargine (Jonasson et al. 2009).

In the Scottish study, analyzing the national registry, a higher risk of breast cancer was found in a small subset of 447 patients receiving only insulin glargine compared to patients receiving also other insulin analogs (RR 1.55, 95% C.I., 1.01–2.37). The authors explained this result as a possible bias because of the small number of events (Colhoun 2009).

In the same year, another retrospective cohort from the United Kingdom, studying 63,000 patients treated by general practitioners with either insulin or oral hypoglycemic agents, found no significant difference in cancer risk comparing users of insulin analogs versus users of human insulin (Currie et al. 2009).

A fifth study published in the same journal reported no increase of cancer in 3,983 diabetic patients treated with insulin detemir in comparison with 2,661 patients treated with NPH insulin (Dejgaard et al. 2009). Moreover, a small but more detailed retrospective case-control study found that cancer was increased in diabetic patients treated with a higher dose of insulin glargine (Mannucci et al. 2010).

Because of their retrospective nature, all these studies can be strongly criticized because patients were not randomized to treatment groups, and many potentially relevant confounders such as body mass index, duration of diabetes, smoking habit, and variable and not constant insulin dosage occurred in all series. Moreover, the follow-up time was very short in most cases (less than 3 years).

The issue of the possible pro-cancer effect of long-acting insulin analogs (especially at high dosage) was strongly debated until the data from a prospective study become available.

The ORIGIN trial was aimed at evaluating the cardiovascular risk in patients treated with glargine insulin. At the same time, the risk of cancer associated with insulin glargine treatment was also evaluated (Gerstein et al. 2012). A total of 12,537 participants were enrolled with an average follow-up of 6.2 years. The authors did not find an increased cancer incidence in the insulin glargine users (HR, 1.00; 95% C.I. 0.88–1.13).

The ORIGIN trial, much cited to exclude the risk of cancer associated with insulin glargine treatment (Gerstein et al. 2012), has several weaknesses. Among them are the average follow-up of only 6.2 years, definitely too short for a potential mild carcinogen to cause cancer, the inclusion of 62% of patients that discontinued glargine treatment temporarily or permanently, the low dose of insulin administered (median 0.3–0.4 units/kg body weight), and the possible interference of different medications such as sulfonylureas (that may favor cancer) and metformin (with an anticancer effect) (Vigneri et al. 2012).

Recently, a systematic review of observational studies, including 16 cohort and 3 case-control studies, examined the association between long-acting insulin analogs and cancer incidence. All studies evaluated insulin glargine and four studies evaluated also insulin detemir. Thirteen out of 15 studies reported no association between insulin glargine or insulin detemir and cancer. Four studies reported an increased risk of breast cancer with insulin glargine. In all these studies, the follow-up was very short (ranged from 0.9 to 7.0 years), and other important methodological shortcomings were present in all of them. For instance, reverse causality was an unexplored possibility: cancer often has a long preclinical period between the biological initiation and the clinical diagnosis. During this subclinical phase, insulin requirements might be affected by the undetected cancer and lead to increased dosage. To the unaware observer, this treatment change can appear as favoring cancer, while vice versa it is cancer that produces the treatment changes (Pocock and Smeeth 2009; Wu et al. 2016).

Moreover, although observational studies can usefully detect unexpected drug effects, they may also favor biased conclusions. In these retrospective studies, the clinical decision determining treatment was not random, and patients were prescribed additional therapies for health-related reasons. Therefore, despite adjustment for confounders, residual selection bias might distort true differences between treatments. For instance, patients with poor glycemic control are more frequently treated with insulin. The difference with patients in better control and receiving oral antidiabetic drugs might result in confounding factors: an increased cancer occurrence may be related not only to drug differences but also to the different metabolic control and general condition of the patient when the therapy is selected. Moreover, the higher doses of insulin required in diabetic patients with poor metabolic control and a cancer can produce an artifact: the higher mortality could be not a true consequence of treatment but rather the consequence of the advancement of the metabolic disease.

In conclusion, the available clinical evidence can neither demonstrate nor exclude an increased risk of cancer in diabetic patients when treated with long-term insulin analogs in comparison with normal insulin.

## Oral Antidiabetic Drugs

The three major oral antidiabetic drug families (sulfonylureas, biguanides, and thiazolidinediones) have a different mechanism of action. Sulfonylureas stimulate endogenous insulin secretion (causing hyperinsulinemia), while the other two

categories of antidiabetic compounds are insulin sensitizers, i.e., they make tissues more responsive to insulin and, therefore, decrease insulin levels. If hyperinsulinemia plays a role in increasing cancer risk and progression in diabetic patients, it is reasonable to expect that these drugs will have a different effect on the association between diabetes and cancer.

The first group of drugs (sulfonylureas) is secretagogues, i.e., increase insulin secretion and cause hyperinsulinemia. As expected, therefore, they have been associated with an increased risk of cancer (Bowker et al. 2006). Different sulfonylureas may have different effects, with glyburide being more deleterious than gliclazide (Monami et al. 2007). The association between sulfonylureas' use in patients with breast cancer and all-cause mortality has been recently evaluated. In 1,057 patients with diabetes diagnosed before the occurrence of breast cancer, sulfonylurea use for less than 2 years was associated with increased breast cancer-specific mortality (adjusted HR 1.70; 95% C.I. 1.18–2.46), but longer use was not (adjusted HR 0.94; 95% C.I. 0.54–1.66). In 706 patients who developed diabetes after breast cancer, sulfonylurea treatment was strongly associated with cancer-specific mortality (adjusted HR 3.64; 95% C.I. 2.16–6.16) (Vissers et al. 2015). Although the sulfonylurea effect on cancer risk is usually attributed to the prolonged hyperinsulinemia that these drugs induce in patients, a direct effect on cancer (either positive or negative) cannot be excluded.

The biguanide metformin is of special interest because it is the recommended first-line treatment in type 2 DM patients and because of the attributed anticancer property.

Since the first observation in 2005 (Evans et al. 2005), many clinical studies have reported a lower prevalence of cancer in diabetic patients treated with metformin. In 10 years nearly 3,000 papers have been published on metformin and cancer, and most clinical studies suggest that in diabetic patients, metformin has a favorable anticancer effect on colon-rectal, breast, prostate, liver, pancreas, gastrointestinal, ovarian, and other cancers (Rizos and Elisaf 2013). Moreover, *in vitro* studies documented an antiproliferative effect of metformin in a variety of experimental models. Metformin has also been tested for cancer prevention in nondiabetic individuals and as an anticancer adjuvant drug in oncologic patients.

A large number of observational clinical studies suggest that treating diabetic patients with metformin reduces cancer incidence and cancer mortality in comparison with other glucose-lowering agents (Yin et al. 2013). This anticancer effect of metformin is not influenced by the additional treatment of diabetes with insulin and/or sulfonylureas and is more evident for some tumors (like liver and breast cancers) suggesting the possibility of a cancer-specific effect of the drug.

However, not all clinical studies found a decreased risk of cancer in patients treated with metformin, and, because of the retrospective design of the clinical studies, the nonrandom allocation of metformin, and the possibility of time-related biases (Suissa and Azoulay 2012), the presence and the relevance of the anticancer effect of metformin in clinical practice are still controversial.

The *in vitro* results consistently indicate that metformin reduces cancer cell proliferation, promotes apoptosis, and reduces the epithelial-mesenchymal transition.



In vitro studies, however, do not necessarily have a high translational value: metformin is usually added to cultured malignant cells at millimolar concentrations, hundred times higher than plasma concentrations reached during patient treatment (Dowling et al. 2012). Therefore, some of the direct effects of metformin reported in vitro may not be relevant in the clinical situation.

The positive effects observed in diabetic patients have suggested that the beneficial anticancer effects of metformin may occur also in nondiabetic patients. Metformin, therefore, has been studied for cancer prevention in both diabetic and nondiabetic individuals. Some evidences indicate that the anticancer action of metformin could be more effective in individuals with insulin resistance, but available data are insufficient to confirm this possibility. Finally, few reports indicate that metformin can potentiate the efficacy of chemotherapy in cancer patients, with prevention of relapse via a specific action on cancer stem cells. These data, however, are only preliminary.

How can metformin, the most used antidiabetes drug, exert such important effects in cancer? Two major mechanisms have been hypothesized.

First, metformin is an insulin sensitizer that reduces insulin resistance and, consequently, lowers the compensatory hyperinsulinemia that is considered a major risk factor for cancer initiation and progression. This indirect, insulin-mediated anticancer effect of metformin is believed to be of key importance in all individuals with hyperinsulinemia including, in addition to type 2 diabetes, obesity, metabolic syndrome, and polycystic ovary syndrome. Second, metformin is believed to have also direct, not insulin-mediated effects on cancer. This biguanide influences cell metabolism because it stimulates the AMP-activated protein kinase (AMPK), an intracellular sensor of nutrient availability, and, therefore, is a major regulator of cellular energy homeostasis. By inhibiting the respiratory chain complex I at mitochondrion level, metformin decreases ATP production with the consequent increase of AMP and ADP which activates the AMPK (Long and Zierath 2006). In the situation of energy deficiency, AMPK is the sensor that will decrease all energy-consuming processes. As already mentioned, cancer cells require more energy than normal cells to survive and grow: metformin, by reducing nutrient availability, will slow down growth for these hungry cells. In addition, AMPK phosphorylation will influence its major upstream activator, the liver kinase B1 (LKB1), a tumor suppressor that negatively regulates mTOR (mammalian target of rapamycin) signaling pathway, which is overactive in most cancers. Metformin, therefore, exerts its direct anticancer effect by stimulating the LKB1/AMPK signaling pathway, a tumor suppressor axis.

Additional anticancer mechanisms of metformin like p53 activation, cell cycle arrest, and promotion of malignant cell apoptosis have also been described in specific cancer cells and indicate that the antiproliferative effect of this drug may follow multiple molecular pathways and mechanisms in different cells (Fig. 3).

The issue of metformin and cancer is relevant for both scientific and socioeconomic aspects because metformin is the most used first-line drug in type 2 diabetes, with minor side effects and with a low cost. Overall the clinical evidences and the plausibility of its mechanisms of action support a favorable anticancer effect of this drug. Although the metformin effect in cancer may be variable, according to the variability of the metabolic and oncologic situation of the individual patient, its use

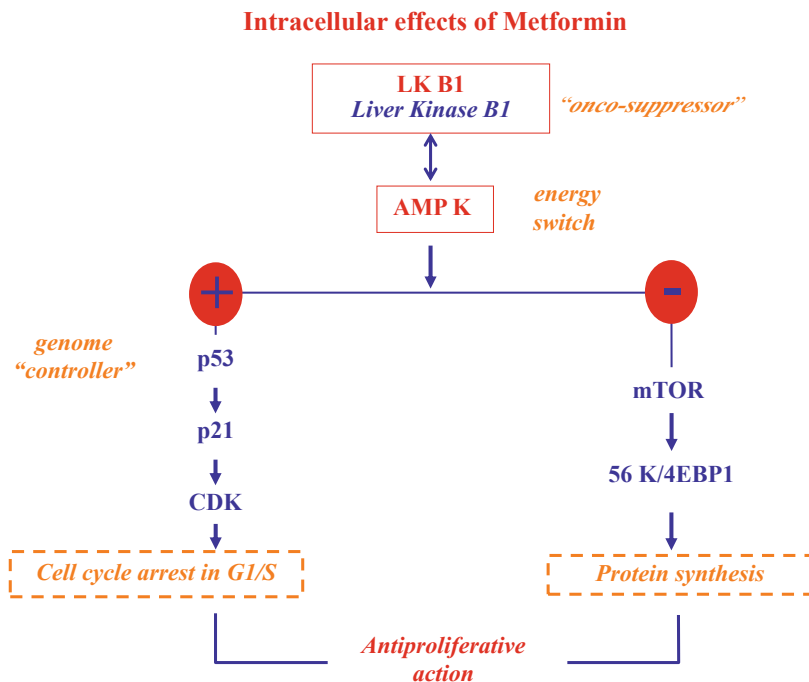

**Fig. 3** Intracellular effects of metformin. In addition to its action as insulin sensitizer, reducing hyperglycemia due to insulin resistance, metformin also has multiple direct effects at intracellular level. These effects reduce cancer cell proliferation with multiple mechanisms that can be AMPK dependent but also independent

for opposing the pro-cancer effect of type 2 diabetes should be recommended because, at worst, metformin is beneficial for its metabolic activity and has no detrimental effect on cancer incidence or mortality when compared to other antidiabetes agents.

The other insulin-sensitizing drugs (thiazolidinediones) are more controversial. Beneficial (Govindarajan et al. 2007), neutral (Koro et al. 2007), or even deleterious (Ramos-Nino et al. 2007) effects have been reported for different types of cancer. Recently thiazolidinediones have been shown to induce differentiation in solid tumors such as thyroid differentiated/anaplastic cancers (Ferrari et al. 2016). The biological mechanism of these compounds is to activate PPARgamma receptors which in several in vitro experimental models have shown a potential anticancer effect (Aiello et al. 2006). In addition to lowering hyperinsulinemia, this additional effect can explain an anticancer effect of glitazones.

### New Antidiabetes Drugs

Glucagon-like peptide 1 receptor (GLP-1R) agonists and GLP-1 degradation inhibitors (dipeptidyl peptidase-4 inhibitor) are drugs that mimic the action of native GLP-1 and have become a common second line therapy for type 2 diabetes.

Incretin use is too recent to have reliable data on their association with cancer. The increased incidence of medullary thyroid cancer reported in rodents has not been confirmed in humans (Vangoitsenhoven et al. 2012). Their trophic effect on  $\beta$ -cells has raised some concerns for a possible pro-cancer effect in pancreatic target cells expressing the receptors (Labuzek et al. 2013). In two trials (SAVOR-TIMI and EXAMINE) (Raz et al. 2014; White et al. 2013) that have evaluated the cardiovascular effects of gliptins, the authors have examined also the risk of pancreatic cancer. The SAVOR-TIMI compared saxagliptin versus placebo with a median 2.1 years follow-up and evaluated pancreatic cancer as a safety outcome. No indication for an increased risk of pancreatic cancer was found (5 events with saxagliptin vs. 12 with placebo) (Raz et al. 2014). The EXAMINE trial, comparing alogliptin versus placebo, found no report of pancreatic cancer with 1.5 years of median follow-up in 5,380 patients (White et al. 2013). With regard to different cancers, other than pancreatic and thyroid cancers, available studies indicated no association between cancer and incretin drug use in humans. Based on the previous evidences, however, continuous monitoring of the cancer issue is required for incretin-based therapies, even though the benefits may outweigh the potential and minimal cancer risk in poorly controlled patients with T2DM.

Sodium-glucose cotransporter 2 (SGLT2) inhibitors are a recently introduced new class of oral glucose-lowering drugs for treating type 2 diabetes. They decrease plasma glucose levels by selectively inhibiting renal glucose reabsorption and increasing urinary glucose excretion. In a recently published meta-analysis of 46 randomized controlled trials (RCTs), 580 incident cases of cancer were observed among 34,569 people with type 2 diabetes. SGLT2 inhibitors were not significantly associated with an increased risk of overall cancer (OR 1.14 [95% C.I. 0.96, 1.36]) when compared with placebo or other glucose-lowering treatments. Therefore, in the short-term (mean trial duration 61 weeks), current evidence does not support a significant association between SGLT2 inhibitors and an increased risk of cancer (Tang et al. 2017). Considering the exposure to increased glucose and the higher frequency of local infections of the genital and urinary excretion system (Rizzi and Trevisan 2016) in SGLT2 inhibitor-treated patients, their long-term effects on cancer remain uncertain.

---

## Cancer Drugs Causing Hyperglycemia and Insulin Resistance

The cancer therapies are addressed to destroy malignant cells by interfering with their metabolic and survival mechanisms. At the same time, cancer drugs may also influence the function and survival of normal cells causing a variety of adverse events including changes in glucose metabolism. The most common consequence in this field is hyperglycemia, often accompanied by hyperinsulinemia. These changes can be of variable severity and duration: severity grade 1–4 of glucose derangement can be either reversible after therapy discontinuation or permanent (newly developed diabetes). At this regard it may be useful to remind diabetologists and

endocrinologists the criteria oncologists use to classify the severity of adverse events as far as glucose level abnormalities are concerned.

Grade	Hyperglycemia (fasting)	Hypoglycemia
1. Mild	126–160 mg/dL	70–55 mg/dL
2. Moderate	>160–250 mg/dL	<55–40 mg/dL
3. Severe	>250–500 mg/dL	<40–30 mg/dL
4. Life-threatening or disabling	>500 mg/dL	<30 mg/dL

The cutoff values for moderate fasting hyperglycemia according to the Common Terminology Criteria for Adverse Events (CTCAE), therefore, can already indicate a serious and urgent metabolic problem in a fragile and often old patient with systemic or organ-specific complications of diabetes and under multiple treatments.

Therefore, the adverse effects of drugs for treating cancer on glucose metabolism can complicate the patient treatment and reduce his/her well-being and also survival when hyperglycemia is severe, up to ketoacidosis or hyperosmolar coma. Moreover, there is considerable evidence that increased glucose and/or insulin levels will increase proliferation, survival, and migration of cancer cells. Therefore, even mild or moderate hyperglycemia and hyperinsulinemia can promote cancer progression and worsen treatment outcome (Brunello et al. 2011; Zeng et al. 2010) with the mechanisms previously indicated.

The most frequent cancer therapies that will affect glucose metabolism in an oncologic patient (and more so in a patient having both diabetes and cancer) are glucocorticoids, hormone therapies, and targeted therapies.

## Glucocorticoids

Glucocorticoids are frequently used in cancer patients at a high dosage to both prevent and/or cure allergic reactions, inflammatory states, and edema and to alleviate fatigue, pain, and nausea. Moreover, glucocorticoids are a relevant component of chemotherapy treatment protocols. Glucocorticoids have a potent diabetogenic effect because at high doses, they cause severe insulin resistance which can be compensated by hyperinsulinemia only when the patient's pancreas is functioning well. Glucocorticoid administration may also result in the worsening of a condition of prediabetes or mild undiagnosed diabetes that can be transformed into a clinically severe illness, possibly leading to the deadly hyperosmolar coma (Clore and Thurby-Hay 2009; Kuo et al. 2015). Due to the high prevalence of diabetes and prediabetes in the aged population (over 15–20%, representing also the population category more prone to cancer), this is a real health risk. The risk level depends on the dose and duration of treatment and the metabolic condition of the patients. At higher risk of unknown diabetes are obese patients with familiarity for diabetes.

This diabetogenic complication of glucocorticoid administration may not be recognized when only fasting glycemia is measured because glucocorticoids mainly alter postprandial glucose, while fasting glucose may be only mildly affected.

Prandial insulin is the treatment of choice in these patients using short-acting analogs. When the patient is an already diagnosed diabetic patient under “basal-bolus” insulin treatment, prandial insulin dose should be increased (Ariaans et al. 2015).

## Antiandrogens and Other Hormonal Therapies

Also *antiandrogens*, frequently used for the treatment of prostate cancer, may adversely affect glucose metabolism. Androgen deprivation therapy causes a variety of metabolic abnormalities that include decreased insulin sensitivity and altered lipid profile and, therefore, increased risk of diabetes and cardiovascular disease (Saylor and Smith 2009). Moreover, androgens are important determinants of body composition: their inhibition increases fat mass and decreases lean body mass. In patients treated with either gonadotropin-releasing hormone agonists (GnRH, whose chronic administration inhibits gonadotropins) and/or nonsteroidal antiandrogens (like flutamide and bicalutamide that compete at receptor level) or cyproterone acetate (a steroid antiandrogen and antigonadotropin), these antiandrogen treatments may cause “sarcopenic obesity,” a combination of excess body weight and reduced muscle mass. Fat accumulation is primarily subcutaneous and is often associated with increased total cholesterol, triglycerides, and HDL. These changes result in insulin resistance, hyperglycemia, and, sometimes, diabetes. Among over 70,000 patients with locoregional prostate cancer, individuals treated with GnRH had a 44% increased risk of developing diabetes (Keating et al. 2006).

Glucose metabolism can also be altered by *somatostatin long-acting analogs*, in particular by pasireotide (Quinn et al. 2012), a novel multireceptor-targeted somatostatin analog (Grasso et al. 2015). These drugs are employed to treat advanced or metastatic neuroendocrine tumors (NET) and inhibit the release of numerous hormones, including insulin and incretins (like glucagon-like peptide-1 [GLP-1] and glucose-dependent insulinotropic polypeptide [GIP]). Hyperglycemia can appear particularly in the period following administration.

## Cancer Drugs Targeting the Insulin Signaling Pathways

Because of the relevant role of insulin and IGF-1 in promoting cancer cell growth, numerous drugs have been developed to inhibit the receptors of these hormones and the intracellular signaling pathways. Due to the role of insulin signaling on glucose metabolism, the inhibition of these pathways may cause hyperglycemia, insulin resistance, and compensatory hyperinsulinemia (Yang et al. 2016; Vigneri et al. 2015).

Different inhibitors targeting different components of the signaling pathway may cause different effects on glucose homeostasis. Within a wide heterogeneity

due to differences in the drugs and also in the patients studied, it appears that PI3K/Akt, IR/IGF-1R, and mTOR inhibitors can cause mild to severe hyperglycemia (Ariaans et al. 2015; Verges and Cariou 2015). Everolimus, an inhibitor of mTOR (mammalian target of rapamycin) often used in breast and kidney cancer, can cause grade 1–2 hyperglycemia in up to 40–50% of patients and grade 3–4 hyperglycemia in up to 10–20% of cases. The use of this drug requires, therefore, glycemic surveillance.

## Approach to Hyperglycemia Induced by Cancer Treatment

Early treatment of hyperglycemia and hyperinsulinemia induced by cancer drugs will not only ameliorate the patient clinical conditions but will also prevent the detrimental effects of the excess of glucose and insulin on cancer growth, recurrence, and resistance to treatment.

Intervention must be personalized to patient characteristics and to the mechanism of the cancer drug-inducing hyperglycemia.

Lifestyle intervention with appropriate diet and exercise is useful in all patients because it can reduce glucose and insulin levels and has been demonstrated to improve cancer survival rates (Pierce et al. 2007; Je et al. 2013). Metformin, a first-line and widely used insulin sensitizer, is a good option in all patients with insulin resistance induced by cancer treatment.

Insulin can be required when an absolute insulin deficiency is present or a short-term effect is necessary (like prandial insulin in glucocorticoid-induced hyperglycemia). In the case of newly diagnosed hyperglycemia due to cancer treatment and requiring insulin, it is important that physicians remember the psychological difficulties of the patient, often resistant to add a complicated treatment schedule with complicated, non-familiar devices (glucometer, glucose monitoring diary, pens, injection procedure and sites) since his/her major worry is the oncologic disease. Both the patient and the physician must not underestimate the deleterious effects of the altered metabolic condition. Hyperglycemia may show no evident signs at the beginning but can make the cancer more resistant to treatment and also cause severe life-threatening conditions like dehydration and hyperosmolar coma. Information and education are, therefore, of major importance for these patients.

The increased risk of cancer incidence and mortality in diabetic patients has become a clinically relevant issue. A very recent report in Australians registered in the National Diabetes Services Scheme indicates that in the years 2000–2011, age-standardized mortality rates in diabetic patients have decreased for all-cause and for cardiovascular diseases but not for cancer (Harding et al. 2016).

Cancer is a leading cause of death in diabetes, has progressively increased, and now accounts for 27% and 33% of all deaths in type 1 and type 2 diabetic patients, respectively (Harding et al. 2015).

This increasing burden of cancer in diabetic patients requires, therefore, attention from scientists, general physicians, and specialists and from health policy-makers.

## References

- Aiello A, Pandini G, Frasca F, Conte E, Murabito A, Sacco A, et al. Peroxisomal proliferator-activated receptor-gamma agonists induce partial reversion of epithelial-mesenchymal transition in anaplastic thyroid cancer cells. *Endocrinology*. 2006;147(9):4463–75.
- Ariaans G, de Jong S, Gietema JA, Lefrandt JD, de Vries EG, Jalving M. Cancer-drug induced insulin resistance: innocent bystander or unusual suspect. *Cancer Treat Rev*. 2015; 41(4):376–84.
- Bansal D, Bhansali A, Kapil G, Undela K, Tiwari P. Type 2 diabetes and risk of prostate cancer: a meta-analysis of observational studies. *Prostate Cancer Prostatic Dis*. 2013;16(2):151–8. S1
- Bao C, Yang X, Xu W, Luo H, Xu Z, Su C, et al. Diabetes mellitus and incidence and mortality of kidney cancer: a meta-analysis. *J Diabetes Complications*. 2013;27(4):357–64.
- Barone BB, Yeh HC, Snyder CF, Peairs KS, Stein KB, Derr RL, et al. Long-term all-cause mortality in cancer patients with preexisting diabetes mellitus: a systematic review and meta-analysis. *JAMA*. 2008;300(23):2754–64.
- Barone I, Catalano S, Gelsomino L, Marsico S, Giordano C, Panza S, et al. Leptin mediates tumor-stromal interactions that promote the invasive growth of breast cancer cells. *Cancer Res*. 2012;72(6):1416–27.
- Barrett-Connor E. Lower endogenous androgen levels and dyslipidemia in men with non-insulin-dependent diabetes mellitus. *Ann Intern Med*. 1992;117(10):807–11.
- Basso D, Valerio A, Seraglia R, Mazza S, Piva MG, Greco E, et al. Putative pancreatic cancer-associated diabetogenic factor: 2030 MW peptide. *Pancreas*. 2002;24(1):8–14.
- Belfiore A, Frasca F, Pandini G, Sciacca L, Vigneri R. Insulin receptor isoforms and insulin receptor/insulin-like growth factor receptor hybrids in physiology and disease. *Endocr Rev*. 2009;30(6):586–623.
- Ben Q, Xu M, Ning X, Liu J, Hong S, Huang W, et al. Diabetes mellitus and risk of pancreatic cancer: a meta-analysis of cohort studies. *Eur J Cancer*. 2011;47(13):1928–37.
- Betancourt-Albrecht M, Cunningham GR. Hypogonadism and diabetes. *Int J Impot Res*. 2003; 15(Suppl 4):S14–20.
- Bonovas S, Filioussi K, Tsantes A. Diabetes mellitus and risk of prostate cancer: a meta-analysis. *Diabetologia*. 2004;47(6):1071–8.
- Bowker SL, Majumdar SR, Veugelers P, Johnson JA. Increased cancer-related mortality for patients with type 2 diabetes who use sulfonylureas or insulin. *Diabetes Care*. 2006;29(2):254–8.
- Brunello A, Kapoor R, Extermann M. Hyperglycemia during chemotherapy for hematologic and solid tumors is correlated with increased toxicity. *Am J Clin Oncol*. 2011;34(3):292–6.
- Calle EE, Rodriguez C, Walker-Thurmond K, Thun MJ. Overweight, obesity, and mortality from cancer in a prospectively studied cohort of U.S. adults. *N Engl J Med*. 2003;348(17):1625–38.
- Carstensen B, Read SH, Friis S, Sund R, Keskimaki I, Svensson AM, et al. Cancer incidence in persons with type 1 diabetes: a five-country study of 9,000 cancers in type 1 diabetic individuals. *Diabetologia*. 2016;59(5):980–8.
- Castillo JJ, Mull N, Reagan JL, Nemr S, Mitri J. Increased incidence of non-Hodgkin lymphoma, leukemia, and myeloma in patients with diabetes mellitus type 2: a meta-analysis of observational studies. *Blood*. 2012;119(21):4845–50.
- Chari ST, Leibson CL, Rabe KG, Ransom J, de Andrade M, Petersen GM. Probability of pancreatic cancer following diabetes: a population-based study. *Gastroenterology*. 2005;129(2):504–11.
- Chari ST, Leibson CL, Rabe KG, Timmons LJ, Ransom J, de Andrade M, et al. Pancreatic cancer-associated diabetes mellitus: prevalence and temporal association with diagnosis of cancer. *Gastroenterology*. 2008;134(1):95–101.
- Chen HF, Li CY, Chen P, See TT, Lee HY. Seroprevalence of hepatitis B and C in type 2 diabetic patients. *J Chin Med Assoc*. 2006;69(4):146–52.
- Chow WH, Gridley G, Fraumeni JF Jr, Jarvholm B. Obesity, hypertension, and the risk of kidney cancer in men. *N Engl J Med*. 2000;343(18):1305–11.
- Clore JN, Thurby-Hay L. Glucocorticoid-induced hyperglycemia. *Endocr Pract*. 2009;15(5): 469–74.

- Colhoun HM. Use of insulin glargine and cancer incidence in Scotland: a study from the Scottish Diabetes Research Network Epidemiology Group. *Diabetologia*. 2009;52(9):1755–65.
- Coughlin SS, Calle EE, Teras LR, Petrelli J, Thun MJ. Diabetes mellitus as a predictor of cancer mortality in a large cohort of US adults. *Am J Epidemiol*. 2004;159(12):1160–7.
- Currie CJ, Poole CD, Gale EA. The influence of glucose-lowering therapies on cancer risk in type 2 diabetes. *Diabetologia*. 2009;52(9):1766–77.
- Davila JA, Morgan RO, Shaib Y, McGlynn KA, El-Serag HB. Diabetes increases the risk of hepatocellular carcinoma in the United States: a population based case control study. *Gut*. 2005;54(4):533–9.
- De Block CE, De Leeuw IH, Van Gaal LF. High prevalence of manifestations of gastric autoimmunity in parietal cell antibody-positive type 1 (insulin-dependent) diabetic patients. The Belgian Diabetes Registry. *J Clin Endocrinol Metab*. 1999;84(11):4062–7.
- De Bruijn KM, Arends LR, Hansen BE, Leeflang S, Ruiter R, van Eijck CH. Systematic review and meta-analysis of the association between diabetes mellitus and incidence and mortality in breast and colorectal cancer. *Br J Surg*. 2013;100(11):1421–9.
- Dejgaard A, Lynggaard H, Rastam J, Krogsgaard Thomsen M. No evidence of increased risk of malignancies in patients with diabetes treated with insulin detemir: a meta-analysis. *Diabetologia*. 2009;52(12):2507–12.
- Dibble CC, Cantley LC. Regulation of mTORC1 by PI3K signaling. *Trends Cell Biol*. 2015; 25(9):545–55.
- Dowling RJ, Niraula S, Stambolic V, Goodwin PJ. Metformin in cancer: translational challenges. *J Mol Endocrinol*. 2012;48(3):R31–43.
- El-Serag HB, Hampel H, Javadi F. The association between diabetes and hepatocellular carcinoma: a systematic review of epidemiologic evidence. *Clin Gastroenterol Hepatol*. 2006;4(3):369–80.
- Elwing JE, Gao F, Davidson NO, Early DS. Type 2 diabetes mellitus: the impact on colorectal adenoma risk in women. *Am J Gastroenterol*. 2006;101(8):1866–71.
- Evans JM, Donnelly LA, Emslie-Smith AM, Alessi DR, Morris AD. Metformin and reduced risk of cancer in diabetic patients. *BMJ*. 2005;330(7503):1304–5.
- Everhart J, Wright D. Diabetes mellitus as a risk factor for pancreatic cancer. A meta-analysis. *JAMA*. 1995;273(20):1605–9.
- Ferrari SM, Materazzi G, Baldini E, Ulisse S, Miccoli P, Antonelli A, et al. Antineoplastic effects of PPARgamma agonists, with a special focus on thyroid cancer. *Curr Med Chem*. 2016;23:636.
- Folsom AR, Anderson KE, Sweeney C, Jacobs DR Jr. Diabetes as a risk factor for death following endometrial cancer. *Gynecol Oncol*. 2004;94(3):740–5.
- Frasca F, Pandini G, Scalia P, Sciacca L, Mineo R, Costantino A, et al. Insulin receptor isoform A, a newly recognized, high-affinity insulin-like growth factor II receptor in fetal and cancer cells. *Mol Cell Biol*. 1999;19(5):3278–88.
- Frasca F, Pandini G, Sciacca L, Pezzino V, Squatrito S, Belfiore A, et al. The role of insulin receptors and IGF-I receptors in cancer and other diseases. *Arch Physiol Biochem*. 2008; 114(1):23–37.
- Friberg E, Orsini N, Mantzoros CS, Wolk A. Diabetes mellitus and risk of endometrial cancer: a meta-analysis. *Diabetologia*. 2007;50(7):1365–74.
- Furstenberger G, Senn HJ. Insulin-like growth factors and cancer. *Lancet Oncol*. 2002;3(5): 298–302.
- Gapstur SM, Gann PH, Lowe W, Liu K, Colangelo L, Dyer A. Abnormal glucose metabolism and pancreatic cancer mortality. *JAMA*. 2000;283(19):2552–8.
- Garofalo C, Surmacz E. Leptin and cancer. *J Cell Physiol*. 2006;207(1):12–22.
- Gerstein HC, Bosch J, Dagenais GR, Diaz R, Jung H, Maggioni AP, et al. Basal insulin and cardiovascular and other outcomes in dysglycemia. *N Engl J Med*. 2012;367(4):319–28.
- Govindarajan R, Ratnasinge L, Simmons DL, Siegel ER, Midathada MV, Kim L, et al. Thiazolidinediones and the risk of lung, prostate, and colon cancer in patients with diabetes. *J Clin Oncol*. 2007;25(12):1476–81.
- Grasso LF, Auriemma RS, Pivonello R, Colao A. Adverse events associated with somatostatin analogs in acromegaly. *Expert Opin Drug Saf*. 2015;14(8):1213–26.



- Green A, Jensen OM. Frequency of cancer among insulin-treated diabetic patients in Denmark. *Diabetologia*. 1985;28(3):128–30.
- Guraya SY. Association of type 2 diabetes mellitus and the risk of colorectal cancer: a meta-analysis and systematic review. *World J Gastroenterol*. 2015;21(19):6026–31.
- Harding JL, Shaw JE, Peeters A, Cartensen B, Magliano DJ. Cancer risk among people with type 1 and type 2 diabetes: disentangling true associations, detection bias, and reverse causation. *Diabetes Care*. 2015;38(2):264–70.
- Harding JL, Shaw JE, Peeters A, Davidson S, Magliano DJ. Age-specific trends from 2000–2011 in all-cause and cause-specific mortality in type 1 and type 2 diabetes: a cohort study of more than one million people. *Diabetes Care*. 2016;39(6):1018–26.
- Harris MI, Flegal KM, Cowie CC, Eberhardt MS, Goldstein DE, Little RR, et al. Prevalence of diabetes, impaired fasting glucose, and impaired glucose tolerance in U.S. adults. The Third National Health and Nutrition Examination Survey, 1988–1994. *Diabetes Care*. 1998;21(4):518–24.
- Hassan MM, Curley SA, Li D, Kaseb A, Davila M, Abdalla EK, et al. Association of diabetes duration and diabetes treatment with the risk of hepatocellular carcinoma. *Cancer*. 2010;116(8):1938–46.
- Hemkens LG, Grouven U, Bender R, Gunster C, Gutschmidt S, Selke GW, et al. Risk of malignancies in patients with diabetes treated with human insulin or insulin analogues: a cohort study. *Diabetologia*. 2009;52(9):1732–44.
- Je Y, Jeon JY, Giovannucci EL, Meyerhardt JA. Association between physical activity and mortality in colorectal cancer: a meta-analysis of prospective cohort studies. *Int J Cancer*. 2013;133(8):1905–13.
- Jonasson JM, Ljung R, Talback M, Haglund B, Gudbjornsdottir S, Steineck G. Insulin glargine use and short-term incidence of malignancies—a population-based follow-up study in Sweden. *Diabetologia*. 2009;52(9):1745–54.
- Kaaks R. Nutrition, hormones, and breast cancer: is insulin the missing link? *Cancer Causes Control*. 1996;7(6):605–25.
- Kalli KR, Falowo OI, Bale LK, Zschunke MA, Roche PC, Conover CA. Functional insulin receptors on human epithelial ovarian carcinoma cells: implications for IGF-II mitogenic signaling. *Endocrinology*. 2002;143(9):3259–67.
- Kasper JS, Giovannucci E. A meta-analysis of diabetes mellitus and the risk of prostate cancer. *Cancer Epidemiol Biomarkers Prev*. 2006;15(11):2056–62.
- Keating NL, O'Malley AJ, Smith MR. Diabetes and cardiovascular disease during androgen deprivation therapy for prostate cancer. *J Clin Oncol*. 2006;24(27):4448–56.
- Kern PA, Ranganathan S, Li C, Wood L, Ranganathan G. Adipose tissue tumor necrosis factor and interleukin-6 expression in human obesity and insulin resistance. *Am J Physiol Endocrinol Metab*. 2001;280(5):E745–51.
- Kido Y, Nakae J, Accili D. Clinical review 125: the insulin receptor and its cellular targets. *J Clin Endocrinol Metab*. 2001;86(3):972–9.
- Koro C, Barrett S, Qizilbash N. Cancer risks in thiazolidinedione users compared to other anti-diabetic agents. *Pharmacoepidemiol Drug Saf*. 2007;16(5):485–92.
- Kuo T, McQueen A, Chen TC, Wang JC. Regulation of glucose homeostasis by glucocorticoids. *Adv Exp Med Biol*. 2015;872:99–126.
- Kurtzals P, Schaffer L, Sorensen A, Kristensen C, Jonassen I, Schmid C, et al. Correlations of receptor binding and metabolic and mitogenic potencies of insulin analogs designed for clinical use. *Diabetes*. 2000;49(6):999–1005.
- Labuzek K, Kozłowski M, Szkudłapski D, Sikorska P, Kozłowska M, Okopien B. Incretin-based therapies in the treatment of type 2 diabetes – more than meets the eye? *Eur J Intern Med*. 2013;24(3):207–12.
- Larsson SC, Orsini N, Wolk A. Diabetes mellitus and risk of colorectal cancer: a meta-analysis. *J Natl Cancer Inst*. 2005;97(22):1679–87.
- Larsson SC, Mantzoros CS, Wolk A. Diabetes mellitus and risk of breast cancer: a meta-analysis. *Int J Cancer*. 2007;121(4):856–62.

- Lee JY, Jeon I, Lee JM, Yoon JM, Park SM. Diabetes mellitus as an independent risk factor for lung cancer: a meta-analysis of observational studies. *Eur J Cancer*. 2013;49(10):2411–23.
- LeRoith D, Roberts CT Jr. The insulin-like growth factor system and cancer. *Cancer Lett*. 2003;195(2):127–37.
- LeRoith D, Yakar S. Mechanisms of disease: metabolic effects of growth hormone and insulin-like growth factor 1. *Nat Clin Pract Endocrinol Metab*. 2007;3(3):302–10.
- Liao C, Zhang D, Mungo C, Tompkins DA, Zeidan AM. Is diabetes mellitus associated with increased incidence and disease-specific mortality in endometrial cancer? A systematic review and meta-analysis of cohort studies. *Gynecol Oncol*. 2014;135(1):163–71.
- Limburg PJ, Vierkant RA, Fredericksen ZS, Leibson CL, Rizza RA, Gupta AK, et al. Clinically confirmed type 2 diabetes mellitus and colorectal cancer risk: a population-based, retrospective cohort study. *Am J Gastroenterol*. 2006;101(8):1872–9.
- Lindblad P, Adami HO. Kidney cancer. In: Adami HO, Hunter D, Trichopoulos D, editors. *Textbook of cancer epidemiology*. New York: Oxford University Press; 2002. p. 467–85.
- Lipscombe LL, Goodwin PJ, Zinman B, McLaughlin JR, Hux JE. The impact of diabetes on survival following breast cancer. *Breast Cancer Res Treat*. 2008;109(2):389–95.
- Long YC, Zierath JR. AMP-activated protein kinase signaling in metabolic regulation. *J Clin Invest*. 2006;116(7):1776–83.
- Luo W, Cao Y, Liao C, Gao F. Diabetes mellitus and the incidence and mortality of colorectal cancer: a meta-analysis of 24 cohort studies. *Colorectal Dis*. 2012;14(11):1307–12.
- Ma J, Li H, Giovannucci E, Mucci L, Qiu W, Nguyen PL, et al. Prediagnostic body-mass index, plasma C-peptide concentration, and prostate cancer-specific mortality in men with prostate cancer: a long-term survival analysis. *Lancet Oncol*. 2008;9(11):1039–47.
- Macheda ML, Rogers S, Best JD. Molecular and cellular regulation of glucose transporter (GLUT) proteins in cancer. *J Cell Physiol*. 2005;202(3):654–62.
- Mannucci E, Monami M, Balzi D, Cresci B, Pala L, Melani C, et al. Doses of insulin and its analogues and cancer occurrence in insulin-treated type 2 diabetic patients. *Diabetes Care*. 2010;33(9):1997–2003.
- Markussen J, Havelund S, Kurtzhals P, Andersen AS, Halstrom J, Hasselager E, et al. Soluble, fatty acid acylated insulins bind to albumin and show protracted action in pigs. *Diabetologia*. 1996;39(3):281–8.
- Mayer D, Shukla A, Enzmann H. Proliferative effects of insulin analogues on mammary epithelial cells. *Arch Physiol Biochem*. 2008;114(1):38–44.
- Meyerhardt JA, Catalano PJ, Haller DG, Mayer RJ, Macdonald JS, Benson AB 3rd, et al. Impact of diabetes mellitus on outcomes in patients with colon cancer. *J Clin Oncol*. 2003;21(3):433–40.
- Mitri J, Castillo J, Pittas AG. Diabetes and risk of non-Hodgkin's lymphoma: a meta-analysis of observational studies. *Diabetes Care*. 2008;31(12):2391–7.
- Monami M, Balzi D, Lamanna C, Barchielli A, Masotti G, Buiatti E, et al. Are sulphonylureas all the same? A cohort study on cardiovascular and cancer-related mortality. *Diabetes Metab Res Rev*. 2007;23(6):479–84.
- Muti P, Quattrin T, Grant BJ, Krogh V, Micheli A, Schunemann HJ, et al. Fasting glucose is a risk factor for breast cancer: a prospective study. *Cancer Epidemiol Biomarkers Prev*. 2002; 11(11):1361–8.
- Nasrallah SN, Reynolds LR. Insulin degludec, the new generation basal insulin or just another basal insulin? *Clin Med Insights Endocrinol Diabetes*. 2012;5:31–7.
- Noy A, Bilezikian JP. Clinical review 63: diabetes and pancreatic cancer: clues to the early diagnosis of pancreatic malignancy. *J Clin Endocrinol Metab*. 1994;79(5):1223–31.
- Oldenburg B, Diepersloot RJ, Hoekstra JB. High seroprevalence of *Helicobacter pylori* in diabetes mellitus patients. *Dig Dis Sci*. 1996;41(3):458–61.
- Pannala R, Leirness JB, Bamlet WR, Basu A, Petersen GM, Chari ST. Prevalence and clinical profile of pancreatic cancer-associated diabetes mellitus. *Gastroenterology*. 2008;134(4):981–7.
- Pannala R, Basu A, Petersen GM, Chari ST. New-onset diabetes: a potential clue to the early diagnosis of pancreatic cancer. *Lancet Oncol*. 2009;10(1):88–95.
- Papa V, Pezzino V, Costantino A, Belfiore A, Giuffrida D, Frittitta L, et al. Elevated insulin receptor content in human breast cancer. *J Clin Invest*. 1990;86(5):1503–10.

- Pierce JP, Stefanick ML, Flatt SW, Natarajan L, Sternfeld B, Madlensky L, et al. Greater survival after breast cancer in physically active women with high vegetable-fruit intake regardless of obesity. *J Clin Oncol*. 2007;25(17):2345–51.
- Pocock SJ, Smeeth L. Insulin glargine and malignancy: an unwarranted alarm. *Lancet*. 2009;374(9689):511–3.
- Quinn TJ, Yuan Z, Adem A, Geha R, Vrikshajanani C, Koba W, et al. Pasireotide (SOM230) is effective for the treatment of pancreatic neuroendocrine tumors (PNETs) in a multiple endocrine neoplasia type 1 (MEN1) conditional knockout mouse model. *Surgery*. 2012;152(6):1068–77.
- Ramos-Nino ME, MacLean CD, Littenberg B. Association between cancer prevalence and use of thiazolidinediones: results from the Vermont Diabetes Information System. *BMC Med*. 2007;5:17.
- Raz I, Bhatt DL, Hirshberg B, Mosenzon O, Scirica BM, Umez-Eronini A, et al. Incidence of pancreatitis and pancreatic cancer in a randomized controlled multicenter trial (SAVOR-TIMI 53) of the dipeptidyl peptidase-4 inhibitor saxagliptin. *Diabetes Care*. 2014;37(9):2435–41.
- Renahan AG, Zwahlen M, Minder C, O'Dwyer ST, Shalet SM, Egger M. Insulin-like growth factor (IGF)-I, IGF binding protein-3, and cancer risk: systematic review and meta-regression analysis. *Lancet*. 2004;363(9418):1346–53.
- Rizos CV, Elisaf MS. Metformin and cancer. *Eur J Pharmacol*. 2013;705(1–3):96–108.
- Rizzi M, Trevisan R. Genitourinary infections in diabetic patients in the new era of diabetes therapy with sodium-glucose cotransporter-2 inhibitors. *Nutr Metab Cardiovasc Dis*. 2016;26(11):963–70.
- Saylor PJ, Smith MR. Metabolic complications of androgen deprivation therapy for prostate cancer. *J Urol*. 2009;181:1998.
- Sciacca L, Costantino A, Pandini G, Mineo R, Frasca F, Scalia P, et al. Insulin receptor activation by IGF-II in breast cancers: evidence for a new autocrine/paracrine mechanism. *Oncogene*. 1999;18(15):2471–9.
- Sciacca L, Cassarino MF, Genua M, Pandini G, Le Moli R, Squatrito S, et al. Insulin analogues differently activate insulin receptor isoforms and post-receptor signalling. *Diabetologia*. 2010;53(8):1743–53.
- Sciacca L, Vigneri R, Tumminia A, Frasca F, Squatrito S, Frittitta L, et al. Clinical and molecular mechanisms favoring cancer initiation and progression in diabetic patients. *Nutr Metab Cardiovasc Dis*. 2013;23(9):808–15.
- Sciacca L, Cassarino MF, Genua M, Vigneri P, Giovanna Pennisi M, Malandrino P, et al. Biological effects of insulin and its analogs on cancer cells with different insulin family receptor expression. *J Cell Physiol*. 2014;229(11):1817–21.
- Shin HY, Jung KJ, Linton JA, Jee SH. Association between fasting serum glucose levels and incidence of colorectal cancer in Korean men: the Korean Cancer Prevention Study-II. *Metabolism*. 2014;63(10):1250–6.
- Shukla A, Grisouard J, Ehemann V, Hermani A, Enzmann H, Mayer D. Analysis of signaling pathways related to cell proliferation stimulated by insulin analogs in human mammary epithelial cell lines. *Endocr Relat Cancer*. 2009;16(2):429–41.
- Sommerfeld MR, Muller G, Tschank G, Seipke G, Habermann P, Kurrle R, et al. In vitro metabolic and mitogenic signaling of insulin glargine and its metabolites. *PLoS One*. 2010;5(3):e9540.
- Stadler J, Yeung KS, Furrer R, Marcon N, Himal HS, Bruce WR. Proliferative activity of rectal mucosa and soluble fecal bile acids in patients with normal colons and in patients with colonic polyps or cancer. *Cancer Lett*. 1988;38(3):315–20.
- Stevens RJ, Roddam AW, Beral V. Pancreatic cancer in type 1 and young-onset diabetes: systematic review and meta-analysis. *Br J Cancer*. 2007;96(3):507–9.
- Suissa S, Azoulay L. Metformin and the risk of cancer: time-related biases in observational studies. *Diabetes Care*. 2012;35(12):2665–73.
- Szlosarek P, Charles KA, Balkwill FR. Tumour necrosis factor-alpha as a tumour promoter. *Eur J Cancer*. 2006;42(6):745–50.
- Tang H, Dai Q, Shi W, Zhai S, Song Y, Han J. SGLT2 inhibitors and risk of cancer in type 2 diabetes: a systematic review and meta-analysis of randomised controlled trials. *Diabetologia*. 2017;60:1862.

- Vangoitsenhoven R, Mathieu C, Van der Schueren B. GLP1 and cancer: friend or foe? *Endocr Relat Cancer*. 2012;19(5):F77–88.
- Vella V, Sciacca L, Pandini G, Mineo R, Squatrito S, Vigneri R, et al. The IGF system in thyroid cancer: new concepts. *Mol Pathol*. 2001;54(3):121–4.
- Vella V, Pandini G, Sciacca L, Mineo R, Vigneri R, Pezzino V, et al. A novel autocrine loop involving IGF-II and the insulin receptor isoform-A stimulates growth of thyroid cancer. *J Clin Endocrinol Metab*. 2002;87(1):245–54.
- Verges B, Cariou B. mTOR inhibitors and diabetes. *Diabetes Res Clin Pract*. 2015;110(2):101–8.
- Vigneri R, Squatrito S, Sciacca L. Insulin and its analogs: actions via insulin and IGF receptors. *Acta Diabetol*. 2010;47(4):271–8.
- Vigneri R, Vigneri P, Frittitta L. Basal insulin and cardiovascular and other outcomes. *N Engl J Med*. 2012;367(18):1761–2; author reply 3–4
- Vigneri PG, Tirro E, Pennisi MS, Massimino M, Stella S, Romano C, et al. The insulin/IGF system in colorectal cancer development and resistance to therapy. *Front Oncol*. 2015;5:230.
- Vissers PA, Cardwell CR, van de Poll-Franse LV, Young IS, Pouwer F, Murray LJ. The association between glucose-lowering drug use and mortality among breast cancer patients with type 2 diabetes. *Breast Cancer Res Treat*. 2015;150(2):427–37.
- Wang C, Wang X, Gong G, Ben Q, Qiu W, Chen Y, et al. Increased risk of hepatocellular carcinoma in patients with diabetes mellitus: a systematic review and meta-analysis of cohort studies. *Int J Cancer*. 2012;130(7):1639–48.
- Warburg O. On the origin of cancer cells. *Science*. 1956;123(3191):309–14.
- Weinstein D, Simon M, Yehezkel E, Laron Z, Werner H. Insulin analogues display IGF-I-like mitogenic and anti-apoptotic activities in cultured cancer cells. *Diabetes Metab Res Rev*. 2009;25(1):41–9.
- White WB, Cannon CP, Heller SR, Nissen SE, Bergenstal RM, Bakris GL, et al. Alogliptin after acute coronary syndrome in patients with type 2 diabetes. *N Engl J Med*. 2013;369(14):1327–35.
- Will JC, Galuska DA, Vinicor F, Calle EE. Colorectal cancer: another complication of diabetes mellitus? *Am J Epidemiol*. 1998;147(9):816–25.
- Williams JA, Goldfine ID. The insulin-pancreatic acinar axis. *Diabetes*. 1985;34(10):980–6.
- Wu JW, Filion KB, Azoulay L, Doll MK, Suissa S. The effect of long-acting insulin analogs on the risk of cancer: a systematic review of observational studies. *Diabetes Care*. 2016;39:486.
- Xu H, Jiang HW, Ding GX, Zhang H, Zhang LM, Mao SH, et al. Diabetes mellitus and prostate cancer risk of different grade or stage: a systematic review and meta-analysis. *Diabetes Res Clin Pract*. 2013a;99(3):241–9.
- Xu X, Wu J, Mao Y, Zhu Y, Hu Z, Lin Y, et al. Diabetes mellitus and risk of bladder cancer: a meta-analysis of cohort studies. *PLoS One*. 2013b;8(3):e58079.
- Yang X, Ko GT, So WY, Ma RC, Yu LW, Kong AP, et al. Associations of hyperglycemia and insulin usage with the risk of cancer in type 2 diabetes: the Hong Kong diabetes registry. *Diabetes*. 2010;59(5):1254–60.
- Yang IP, Tsai HL, Huang CW, Lu CY, Miao ZF, Chang SF, et al. High blood sugar levels significantly impact the prognosis of colorectal cancer patients through down-regulation of microRNA-16 by targeting Myb and VEGFR2. *Oncotarget*. 2016;7(14):18837–50.
- Yin M, Zhou J, Gorak EJ, Quddus F. Metformin is associated with survival benefit in cancer patients with concurrent type 2 diabetes: a systematic review and meta-analysis. *Oncologist*. 2013;18(12):1248–55.
- Yuan JM, Castelao JE, Gago-Dominguez M, Ross RK, Yu MC. Hypertension, obesity and their medications in relation to renal cell carcinoma. *Br J Cancer*. 1998;77(9):1508–13.
- Zendejdel K, Nyren O, Ostenson CG, Adami HO, Ekblom A, Ye W. Cancer incidence in patients with type 1 diabetes mellitus: a population-based cohort study in Sweden. *J Natl Cancer Inst*. 2003;95(23):1797–800.
- Zeng L, Biernacka KM, Holly JM, Jarrett C, Morrison AA, Morgan A, et al. Hyperglycaemia confers resistance to chemotherapy on breast cancer cells: the role of fatty acid synthase. *Endocr Relat Cancer*. 2010;17(2):539–51.

- Zhang ZH, Su PY, Hao JH, Sun YH. The role of preexisting diabetes mellitus on incidence and mortality of endometrial cancer: a meta-analysis of prospective cohort studies. *Int J Gynecol Cancer*. 2013;23(2):294–303.
- Zhu Z, Wang X, Shen Z, Lu Y, Zhong S, Xu C. Risk of bladder cancer in patients with diabetes mellitus: an updated meta-analysis of 36 observational studies. *BMC Cancer*. 2013;13:310.
- Zucchetto A, Dal Maso L, Tavani A, Montella M, Ramazzotti V, Talamini R, et al. History of treated hypertension and diabetes mellitus and risk of renal cell cancer. *Ann Oncol*. 2007; 18(3):596–600.



Jakob Starup-Linde and Søren Gregersen

## Contents

Definition of Diabetic Bone Disease .....	412
Epidemiology of Fracture in Patients with Diabetes .....	412
Burden of Fracture in Patients with Diabetes .....	413
Bone Mineral Density .....	413
Other Fracture Predictors .....	414
Medication Associated with Osteoporosis .....	415
FRAX .....	416
Bone Remodeling and Pathophysiology of Osteoporosis .....	416
Regulation of Bone Remodeling .....	417
Pathogenesis of Osteoporosis .....	417
Pathophysiology of Diabetic Bone Disease .....	417
Bone Remodeling .....	418
Insulin and Incretins .....	419
Advanced Glycation End Products and HbA1c .....	420
Falls, Hypoglycemia, and Diabetes Complications .....	421
Antidiabetic Drugs and Diabetic Bone Disease .....	421
Lipid-Lowering Drugs .....	422
Antihypertensives .....	423
Potential Predictors of Diabetic Bone Disease .....	423
Comorbidities .....	423
Recent Scanning Modalities .....	424
Microindentation .....	425
Bone Turnover Markers .....	425
Diagnostic Approach to Diabetic Bone Disease .....	426
Treatment of Diabetic Bone Disease .....	428
Future Perspectives .....	429
Implications .....	429

---

J. Starup-Linde (✉) · S. Gregersen  
Department of Endocrinology and Internal Medicine, Aarhus University Hospital,  
Aarhus, Denmark  
e-mail: [Jakob.Linde@auh.rm.dk](mailto:Jakob.Linde@auh.rm.dk); [soeren.gregersen@aarhus.rm.dk](mailto:soeren.gregersen@aarhus.rm.dk)

Summary .....	429
Cross-References .....	430
References .....	430

---

### Abstract

Diabetes is associated with an increased risk of fracture. Commonly used risk factors underestimate the increased fracture risk, whereas they are solid predictors in subjects without diabetes. Bone mineral density measurements which are used for diagnosis of osteoporosis underestimate the fracture risk in patients with diabetes. Diabetes is a state of low bone turnover which may contribute to increased bone fragility. The low bone turnover is likely to be due to hyperglycemia and altered incretin response. Furthermore, diabetes may glycosylate bone collagen, which may reduce bone strength. Presently no specific treatment strategy is available for diabetes in regard to the bone. Although most anti-osteoporotic treatments seem to be safe, the benefit may be less when treating a low bone turnover disease. This chapter highlights the epidemiology, mechanisms, diagnosis, and treatment of diabetic bone disease.

---

### Keywords

Type 1 diabetes · Type 2 diabetes · Fracture · Hip fracture · Vertebral fracture · Hyperglycemia · Bone turnover · Incretins · Bone mineral density · Cortical porosity · Diagnosis · Diabetic bone disease · Collagen · Advanced glycosylation end products · High-resolution peripheral quantitative computed tomography · Comorbidities · Glucose-lowering drugs · Anti-osteoporotic treatment

---

## Definition of Diabetic Bone Disease

Diabetic bone disease occurs in patients with diabetes mellitus, where the fracture risk is increased in spite of normal to increased bone mineral density. Diabetic bone disease is asymptomatic before a fracture. Furthermore, the diabetic bone disease is characterized by a low bone turnover.

---

## Epidemiology of Fracture in Patients with Diabetes

Osteoporosis is a highly prevalent disease with an estimated 200 million suffering from it worldwide (IOF 2015). Osteoporosis leads to an increased risk of fractures especially at the hip, vertebrae, and forearm. Primary osteoporosis is related to aging due to an increased bone resorption relative to bone formation and for women a dramatic loss of bone mass at menopause (Khosla and Riggs 2005). Secondary causes of osteoporosis include use of glucocorticoids, smoking, alcohol abuse, malabsorption of nutrients, and low intake of vitamin D and calcium. Recently, it has become apparent that diabetes may also increase the risk of osteoporosis.

A worldwide estimate is that 387 million suffer from diabetes (International Diabetes Federation 2014). Given the high prevalence rates, it is evident that coexistence of diabetes and osteoporosis is common.

### **Burden of Fracture in Patients with Diabetes**

In a meta-analysis it was found that the risk of a hip fracture was sevenfold increased in patients with type 1 diabetes and 1.4-fold increased in patients with type 2 diabetes both compared with nondiabetic controls (Vestergaard 2007). Similar estimates have been confirmed by other meta-analyses (Fan et al. 2015; Shah et al. 2015; Janghorbani et al. 2007). With an increasing prevalence of diabetes, the total hip fracture burden would also increase (Starup-Linde et al. 2016a). In contrast to hip fractures, the risk of vertebral fractures is apparently not increased in patients with diabetes; however, this finding may be caused by misclassification bias. Observational studies tend to rely on registries based on clinical findings, and an X-ray of the spine is only performed by indication or chance finding on a CT scan, and therefore many cases of vertebral fracture may go undiagnosed. Prevalences of 37–50% have been reported for a vertebral fracture in diabetes populations based on the Genant classification (Herrera et al. 2015; Kiyohara et al. 2015; Starup-Linde et al. 2016c). This prevalence is higher compared with reports from population-based studies, where 19% of women aged 70 had a prevalent vertebral fracture (Waterloo et al. 2012). These findings strongly suggest that patients with diabetes also are at increased risk of vertebral fractures. Both men and women with diabetes are at an increased risk of hip fracture. A meta-analysis stratified by gender revealed five- and fourfold increases in fracture for women and men with type 1 diabetes compared with nondiabetic controls, respectively (Shah et al. 2015). The age-related fracture incidence was increased at all ages for both men and women with type 1 diabetes compared with nondiabetic controls (Weber et al. 2015). Also, when stratifying patients with type 2 diabetes by gender, both men and women were at increased risk of hip fracture (Janghorbani et al. 2007). Hip fractures are especially increased in patients with diabetes younger than 60 years compared with controls but are also increased at older ages. Both patients with type 1 or type 2 diabetes irrespective of age and gender are at an increased risk of fracture. Thus diabetes constitutes a secondary risk for osteoporosis. Both vertebral fractures and hip fractures are associated with an increased mortality risk caused mainly by cardiovascular disease and subsequent infections (Hasserijs et al. 2005; Panula et al. 2011). Consequently, both fracture prediction and prevention are important especially in patients with diabetes that are at a higher risk of cardiovascular disease and infections.

### **Bone Mineral Density**

Osteoporosis is diagnosed by the presence of low-energy fractures or by a decreased bone mineral density usually measured by a dual energy X-ray absorptiometry scan.



Low-energy fractures are a sign of decreased bone biomechanical competence and increased bone fragility, which may be due to a decreased bone mineral density. Bone mineral density is usually given as a T-score that relates the present bone mineral density to that of a 30-year-old gender-matched reference population. In primary osteoporosis a decreased bone mineral density is the cause of an increased fracture risk. In diabetic bone disease, the picture is different. Patients with type 1 diabetes have a decreased bone mineral density; however, the lower BMD per se only predicts a 1.4-fold increase in hip fracture and not the observed sevenfold increase (Vestergaard 2007). Conversely, patients with type 2 diabetes have an increased bone mineral density that predicts a 23% decreased risk of fracture compared to controls (Vestergaard 2007). Thus a paradox exists: Although patients with type 2 diabetes have a higher bone mineral density, they have an increased risk of fractures. It has been suggested that a higher T-score threshold should be used to predict fracture in elderly patients with type 2 diabetes (Schwartz et al. 2011). To suggest a specific T-score threshold in patients with diabetes, studies of younger diabetes individuals and investigation of type 1 and type 2 diabetes separately are needed because the fracture burden is increased mainly in younger age groups with type 1 diabetes.

## Other Fracture Predictors

A previous major fracture is an important predictor of an osteoporotic fracture both due to decreased bone biomechanical competence and a distorted bone structure. Individuals with a previous vertebral fracture have an 11–14-fold increased risk of a subsequent vertebral fracture due to a different mechanical loading of the bone and increased bone fragility (Melton III et al. 1999). In patients with diabetes, a previous fracture is also an established predictor (Starup-Linde et al. 2016b). Furthermore, smoking and alcohol use are associated with the incidence of diabetes (Foy et al. 2005; Carlsson et al. 2003) and are also risk factors for fracture (Kanis et al. 2005a, b). Both smoking and alcohol use are equally good fracture predictors in patients with diabetes and controls (Leslie et al. 2014). However, in observational studies, information on smoking and alcohol use is frequently inaccurate or missing or may be assessed by proxy variables only. Very low body mass index increases the risk of fracture, and increasing body mass index may protect against fractures although this is still controversial. Type 2 diabetes is associated with obesity (American Diabetes Association 2012) causing insulin resistance and inflammation (Esser et al. 2014). While the effects of insulin resistance at tissue level in humans have not been investigated, inflammation may increase bone resorption by increased nuclear factor kappa beta signaling (Khosla 2001). Furthermore, obesity may increase the deposits of fat in the bone and bone marrow. Bone marrow adipose tissue (BMAT) is known to increase with higher age, obesity, and diabetes (Lecka-Czernik et al. 2010). Inverse correlation between bone and BMAT formation has been observed, which suggests a shift toward adipogenesis rather than osteogenesis (Gimble et al. 2006). A similar mechanism applies for the glitazones (see the section “[Antidiabetics and](#)

**Table 1** Lists of known major fracture predictors and discrepancies between osteoporosis and diabetic bone disease

Fracture predictors in osteoporosis	Fracture predictors in diabetic bone disease
Increasing age	Increasing age, but also high risk at young age
Female gender	Female gender
Decreased bone mineral density	Decreased bone mineral density – Performs less well in patients with diabetes
Vitamin D deficiency	Vitamin D deficiency – Common in diabetes but with unknown effects on fracture risk
Smoking	Smoking
Alcohol	Alcohol
Malnutrition	Malnutrition. Type 2 diabetes is in general associated with obesity
Oral glucocorticoids	Oral glucocorticoids – However seldom used in diabetes due to hyperglycemia
Antiepileptics	Antiepileptics
FRAX	FRAX – Underestimates fracture risk in patients with diabetes
Pancreatitis	Pancreatitis – Type 3c diabetes may affect fracture risk
Comorbidities (thyroid disease, celiac disease, etc.)	Comorbidities (thyroid disease, celiac disease, etc.) – Autoimmune comorbidities are more frequent in patients with type 1 diabetes
Falls	Falls – Falls may be more frequent in diabetes due to complications, hypoglycemia, and orthostatic hypotension Glitazones – Increase fracture risk in diabetes Hyperglycemia – High levels of HbA1c are associated with increased risk of fracture

Diabetic Bone Disease”). The glitazones increase fracture risk by increasing the amount of fat in the bone; thus obesity may theoretically increase the fracture risk by a similar mechanism. However, the extraskelatal fat deposits in obese subjects and patients with type 2 diabetes may act as internal hip protectors (Chapman 2010) that theoretically would decrease fracture risk related to falls (Santesso et al. 2014; Kannus et al. 2000). A meta-analysis revealed a decreased risk of hip fracture in obese individuals (Tang et al. 2013) that may relate to the protective fat deposits and internal hip protectors. Thus, the increased body mass index and fat mass in patients with type 2 diabetes do not explain the increased risk of fractures (Table 1).

### Medication Associated with Osteoporosis

Oral glucocorticoids and antiepileptics are both drugs that increase the risk of fracture. Use of oral glucocorticoids may induce diabetes (Hwang and Weiss 2014) and bone loss (Canalis et al. 2007). The effects of glucocorticoid use on

fracture risk seem to be comparable in individuals with and without diabetes (Leslie et al. 2014). However, obese patients with diabetes may have a higher production of endogenous cortisol by an increased activity of the hypothalamic, hypophyseal, and adrenal axis.

Antiepileptics are used as treatment of neuropathic pain in patients with diabetes. In addition, antiepileptics may also be used as seizure prevention and thus represent individuals at risk of fracture. Antiepileptic treatment is also a risk factor for fracture in patients with diabetes (Starup-Linde et al. 2016b). Antiepileptics may thus enhance the risk of fracture in patients with diabetes.

## FRAX

The Fracture Risk Assessment Tool (FRAX) predicts 10-year fracture risks by using fracture predictors as age, gender, bone mineral density, body mass index, family history of fracture, previous fracture, alcohol use, and smoking. FRAX underestimates the risk of both hip fracture and major osteoporotic fracture in patients with diabetes, whereas it performs very well in nondiabetes individuals (Giangregorio et al. 2012). The risk factors used in the FRAX model are, besides age, equally good fracture predictors in patients with and without diabetes; however, the model is less informative in diabetes (Leslie et al. 2014). Current common fracture predictors do not explain the increased fracture risk in patients with diabetes, and therefore other pathophysiological mechanisms may apply to this type of fracture.

---

## Bone Remodeling and Pathophysiology of Osteoporosis

Bone remodeling consists of bone resorption performed by the osteoclasts and bone formation performed by the osteoblasts. The process of bone resorption lasts 3 weeks and bone formation 3 months (Imai et al. 2013). Osteoclasts adhere to the underlying bone and create a sealing zone where bone-resorbing acidic proteases are secreted (Boyle et al. 2003; Pierce et al. 1991). Degradation products of bone resorption are released into the blood. These products include calcium, phosphate, and collagen degradation products (C-terminal cross-linked telopeptide of type I collagen (CTX), N-terminal cross-linked telopeptide of type I collagen (NTX)) and tartrate-resistant acid phosphatase (TRAP) which is a marker of osteoclast activity. These bone resorption markers are measurable in peripheral blood (Starup-Linde and Vestergaard 2016).

After the process of bone resorption, osteoblasts first migrate to the resorbed area and produce the non-mineralized matrix that includes collagen and secondly perform the mineralization of the newly created bone (Imai et al. 2013). During the process of bone formation, the collagen marker PINP, the osteoblast marker osteocalcin, and the mineralization marker bone-specific alkaline phosphatase are released to the peripheral blood. These bone formation markers are measurable in peripheral blood (Starup-Linde and Vestergaard 2016). The osteocytes are encased osteoblasts that

regulate bone remodeling in particular by production of sclerostin as a response to mechanical loading (Bonewald 2011).

## Regulation of Bone Remodeling

The process of bone remodeling is controlled by the signaling of parathyroid hormone (PTH), receptor activator of nuclear factor kappa beta ligand (RANKL), osteoprotegerin (OPG), and sclerostin. All these markers are measurable in the peripheral blood. PTH is produced by the parathyroid gland as a response to low blood calcium (Hall and Guyton 2011) and activates osteoclasts to release calcium to the blood. RANKL is produced by the osteoblasts and binds to the RANK receptor on the osteoclast. The RANKL/RANK interaction increases osteoclast differentiation and activity and is thus a powerful promoter of bone resorption. OPG is the antagonist of RANKL. OPG is also produced by the osteoblast and regulates osteoclast activity (Khosla 2001). Sclerostin is an inhibitor of bone formation by antagonizing the Wnt pathway. The Wnts bind to the low-density lipoprotein receptor-related proteins 5 and 6 on the osteoblasts and thereby enhance bone formation.

## Pathogenesis of Osteoporosis

The pathogenesis in primary osteoporosis is an increased bone resorption to bone formation ratio either via an increased bone resorption or a decreased bone formation. Thereby the bone loss is greater than the generation of new bone and is measurable as a decrease in bone mineral density. The bone mass peaks at age 35, and hereafter there is an annual age-related bone loss due to an increase in bone resorption to bone formation ratio. Women are more prone to osteoporosis due to a rapid decline in estrogen production during menopause and thus develop osteoporosis earlier in life than men. Estrogen is a potent antiresorptive by directly inhibiting osteoclast activity and bone resorption. In men the loss is less rapid; however over time men also have an increased bone resorption and are susceptible to osteoporosis. Among secondary causes of osteoporosis, glucocorticoids generate a bone loss through a direct inhibition of the osteoblast and by competitively inhibiting estrogens and growth hormone that increase osteoclast activity and bone resorption (Canalis et al. 2007). Other secondary causes as hyperthyroidism and smoking also decrease bone mineral density by an altered bone resorption to bone formation ratio.

---

## Pathophysiology of Diabetic Bone Disease

Diabetic bone disease is related to a decreased biomechanical competence although bone mineral density is normal to increased. The bone material strength is lower among patients with diabetes as shown in microindentation studies (Farr et al. 2014; Furst et al. 2016). Several factors may contribute to developing diabetic bone

disease. An increased fracture risk may be due to decreased bone strength because of impaired bone mineral content, impaired collagen strength, or deficits in bone matrix. Furthermore, falls caused by hypoglycemia, diabetes complications (as neuropathy and retinopathy), and concomitant medication (as antihypertensives) may increase the risk of fracture in patients with diabetes.

## Bone Remodeling

Under *in vitro* conditions, human osteoblasts exposed to hyperglycemic conditions increase their mineralization at 12 and 24 mmol/L glucose compared to 5.5 mmol/L glucose; however, the produced minerals are of low quality due to a decreased calcium/phosphate ratio (Garcia-Hernandez et al. 2012). Osteoclasts exposed to hyperglycemia decrease TRAP activity, RANKL-induced osteoclastogenesis, and pit resorption area (Xu et al. 2014, 2015). These *in vitro* studies suggest that bone remodeling is decreased by hyperglycemia but bone mineralization is increased. Bone biopsies are seldom performed in patients with diabetes. Only three studies have reported on this with 5, 8, and 18 diabetes participants, respectively. The two studies with fewest participants reported decreased bone turnover, whereas the other study reported no difference in bone turnover compared with nondiabetic controls (Krakauer et al. 1995; Manavalan et al. 2012; Armas et al. 2012). Thus results from bone tissue biopsies are conflicting and sparse due to few studies and low numbers of patients. In human studies investigating markers of bone remodeling in the peripheral blood, patients with diabetes have lower levels of CTX and osteocalcin compared to nondiabetic controls; furthermore other markers as P1NP tended to be lower, whereas bone-specific alkaline phosphatase and thus bone mineralization are unaffected (Starup-Linde and Vestergaard 2016; Starup-Linde et al. 2014). Furthermore, both sclerostin and OPG levels are increased in patients with diabetes compared with controls, which may cause the lower bone turnover. The decrease in bone remodeling markers may be due to hyperglycemia. CTX, P1NP, and osteocalcin were all inversely associated with plasma glucose levels in patients with diabetes, whereas the OPG levels are associated with plasma glucose levels (Starup-Linde et al. 2016d). Hyperglycemia may thus either directly, by affecting osteoclasts and osteoblasts, or indirectly, by an increase in OPG, decrease bone remodeling. Besides a possible direct effect of glucose on bone remodeling, studies investigating the impact of an oral glucose tolerance test and bone remodeling suggest a role of gastrointestinal hormones. An oral glucose tolerance test decreases the bone remodeling markers CTX, P1NP, and osteocalcin within 20 min in young healthy individuals; however, the effect is abolished with a somatostatin infusion (Clowes et al. 2003). Similar effects are also seen by food ingestion (Henriksen et al. 2003). Somatostatin is a universal hormone inhibitor and inhibits insulin and gastrointestinal hormones, and therefore these factors may be related to bone remodeling. Furthermore, patients with diabetes have a decreased response of CTX to the oral glucose tolerance test, although they have decreased levels at baseline (Chailurkit et al. 2008). CTX also decreases in an intravenous

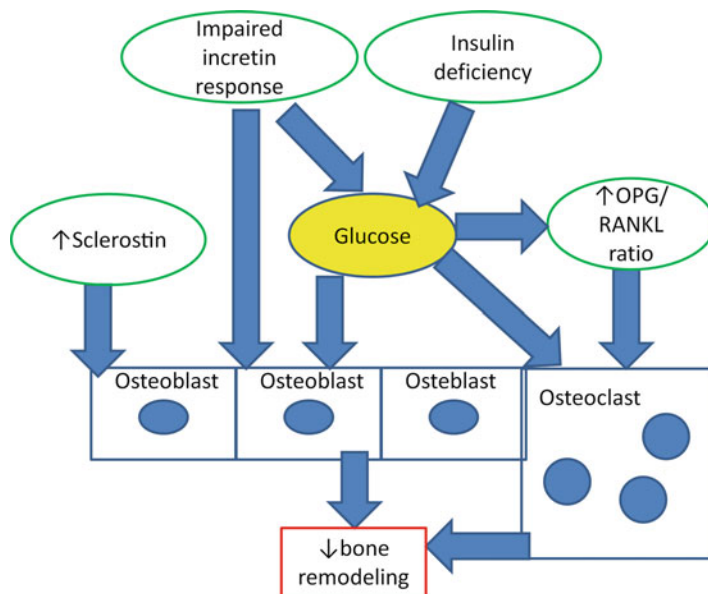

**Fig. 1** Glucose may directly affect osteoblasts and osteoclasts and decrease bone turnover. This may be enhanced by a lack of insulin and incretin hormones. Furthermore, insulin and incretins may also directly decrease bone remodeling by interacting with the osteoblasts and osteoclasts. Sclerostin levels are increased in patients with diabetes, which may relate to a dysfunction of osteocytes. This finding has not been coupled to other diabetes characteristics

glucose tolerance test but to a lesser extent than during an oral glucose tolerance test in healthy women (Bjarnason et al. 2002). These data suggest that insulin, incretin hormones (glucagon-like peptide-1 (GLP-1) and gastric inhibitory peptide (GIP)), and other gastrointestinal hormones may affect bone remodeling in response to a glucose load and therefore also seem to play a role in diabetic bone disease. Figure 1 displays mechanisms that may explain the decreased bone turnover in patients with diabetes.

## Insulin and Incretins

Insulin and incretin hormones are important factors in the development of diabetes and also the treatment of diabetes. These hormones may also interact with the bone. Interestingly, different physiological levels of insulin did not change the CTX response in nondiabetes individuals and patients with diabetes (Basu et al. 2011). Furthermore, subcutaneous injections of GLP-1 did not alter the CTX level in postmenopausal women (Henriksen et al. 2003); however, long-term treatment was protective against BMD loss in obese women on a weight-reducing program (Torekov et al. 2015). GLP-1 receptors have only been identified in osteoblast precursor cells (Pacheco-Pantoja et al. 2011) suggesting that potential effects of

GLP-1 on bone turnover are at the osteoblast recruitment phase, and therefore it is not surprising that GLP-1 did not decrease CTX. GIP injection did not decrease CTX (Henriksen et al. 2003); however, GIP in combination with hyperglycemia decreased CTX to a larger extent than GIP or hyperglycemia alone (Nissen et al. 2014). Osteoclasts and osteoblasts have receptors for GIP, and GIP decreases the resorptive activity of osteoclasts and increases type I collagen synthesis and alkaline phosphatase activity of osteoblasts in vitro (Bollag et al. 2000; Zhong et al. 2007). Furthermore, in murine models, GIP receptor knockout mice decreases bone mass, and overexpression of GIP receptors increases bone mass (Xie et al. 2005, 2007). The incretin response is altered in patients with type 2 diabetes. GLP-1 secretion is lower postprandially compared with nondiabetic subjects, whereas the evidence on GIP is conflicting (Holst et al. 2011). Thus, incretins may be coupled to bone turnover and thus potentially play an important role in diabetic bone disease. Theoretically, hyperglycemia may lead to a decreased bone turnover with hypermineralization by the osteoblast causing fragile bone that elicits high bone mineral density.

## Advanced Glycation End Products and HbA1c

In patients with diabetes, glucose levels are associated with an increased production of advanced glycosylation end products (Kostolanska et al. 2009). Advanced glycosylation end products have been shown to relate to decreased bone formation in rats, whereas bone mineralization was unaffected (Yang et al. 2016). Enzymatic collagen cross-linking plays a significant role for the bone biomechanical competence. Collagen supports bone tissue strength and elasticity. However, the enzymatic cross-links may, by glycation and oxidation, turn into nonenzymatic advanced glycation end products (Saito et al. 2014). The advanced glycation end product cross-links are weaker and may decrease bone quality and thereby bone biomechanical competence. In patients with type 2 diabetes, bone material strength measured by microindentation is inversely related to advanced glycation end products determined by skin autofluorescence (Furst et al. 2016). Also in mice with type 1 diabetes, the accumulation of advanced glycation end products was related to decreased bone mechanical strength (Rubin et al. 2016). If diabetic bone disease is caused by collagen defects due to advanced glycation end products, the bone mineral density is unaffected and may even be increased due to a decreased bone turnover caused by the diabetic state. Thus, the mean glyceic burden measured by glycosylated hemoglobin A1c (HbA1c) may play a very important role in the pathogenesis of diabetic bone disease. The risk of hip fracture and any fracture is increased with HbA1c levels above 9% compared to levels of 6–7% in cohorts of patients with diabetes (Li et al. 2015; Conway et al. 2016), and a 1% increase in HbA1c is associated with almost a doubled risk of fracture (Neumann et al. 2014). However, in a randomized controlled trial, no differences in falls or fracture between standard glyceic control (HbA1c of 7.5%) and intensive glyceic control (HbA1c of 6.4%) were observed; however, only 19 hip fractures were observed in 7287 patients (Schwartz et al. 2012).

---

## Falls, Hypoglycemia, and Diabetes Complications

In regard to falls, retinopathy and neuropathy may increase the risk of falls due to decreased vision and decreased peripheral sensibility. However, registry-based studies of patients with diabetes with no complications show an increased risk of fractures. Furthermore, no specific diabetes-related complication could explain the increased risk of fracture (Vestergaard et al. 2009). Hypoglycemia may cause falls and thereby also increase the risk of fracture, but after adjustment for documented hypoglycemic events, patients with diabetes are still at an increased risk of falls (Vestergaard et al. 2005). Studies that adjust fracture risk by self-reported falls also find an increased risk of fractures in patients with diabetes (Bonds et al. 2006; Schwartz et al. 2001; Napoli et al. 2014), and an increased risk of fall-related fractures has been reported in patients with diabetes (Lee and Colon-Emeric 2014).

Falls due to these mechanisms may contribute to the fracture risk; however, it does not fully explain the increased risk of fractures, which suggests additional underlying mechanisms such as deficits in bone biomechanical competence.

---

## Antidiabetic Drugs and Diabetic Bone Disease

Treatment of diabetes and prevention of complications include glucose-lowering drugs, lipid-lowering drugs, and antihypertensives in order to address important risk factors underlying the increased risk of cardiovascular disease. It is important to be aware of the fact that the antidiabetic treatment may also have an effect on the bone besides a direct influence of hyperglycemia and diabetes-related risk factors. It is mainly observational studies that have reported on the effect of antidiabetics on bone turnover and fracture risk in patients with diabetes. Glitazones have been investigated in randomized controlled trials. The randomized controlled trials have concluded that glitazones increase fracture risk, which is caused by recruitment of osteoblastic precursors into the adipocytic lineage, thus decreasing bone mineral density and increasing bone marrow fat content (Lecka-Czernik 2010; Meier et al. 2015). Therefore, CTX and P1NP levels increase during treatment with glitazones (van Lierop et al. 2012). Insulin use has shown neutral effects on fracture risk in patients with diabetes (Starup-Linde et al. 2016b; Vestergaard et al. 2005) despite the increased risk of hypoglycemia. Long-acting insulins have been associated with a decreased risk of nocturnal hypoglycemia compared to neutral protamine Hagedorn insulin (Brunton 2007), suggesting that they may be safer in terms of falls. Furthermore, a cohort study observed a decreased fracture risk among users of long-acting insulin compared to intermediate insulin users (Pscherer et al. 2016). The type of insulin may thus influence fracture risk through either a higher or lower risk of hypoglycemia. Metformin decreased fracture risk compared to rosiglitazone in a randomized controlled trial (Kahn et al. 2008), and observational studies have suggested protective effects of metformin on fracture risk in patients with diabetes (Vestergaard et al. 2005; Palermo et al. 2015). Metformin decreases bone turnover as CTX and P1NP decrease during treatment (van Lierop et al. 2012). There is no



preclinical evidence of detrimental effects of sulfonylurea on bone cells; however, sulfonylureas are like insulins related to hypoglycemia due to increased beta cell activity. Although the evidence is limited, no increased risk of falls in the sulfonylurea-treated individuals has been observed (Lapane et al. 2013). In general, sulfonylureas show neutral effects on fracture risk although a reduced risk of hip fracture has been reported (Vestergaard et al. 2005). Neither does the cumulative dose of sulfonylurea increase the risk of hip fracture (Colhoun et al. 2012). Even so, an increased risk of a non-vertebral fracture has been reported among sulfonylurea users (Napoli et al. 2014), and sulfonylurea-treated patients with type 2 diabetes observed for 4 years of treatment had an increased risk of fracture compared to matched individuals (Rajpathak et al. 2015).

Newer therapies as the dipeptidyl peptidase IV (DPP-IV) inhibitors, GLP-1 receptor agonists, and sodium/glucose cotransporter-2 (SGLT-2) inhibitors have been investigated with regard to bone metabolism and fracture risk; however, the evidence is yet sparse. Neither treatment with the DPP-IV inhibitors nor the GLP-1 receptor agonists seem to impact bone turnover assessed by circulating bone turnover makers (Palermo et al. 2015). The DPP-IV inhibitors have shown neutral outcomes in observational studies (Driessen et al. 2015b), but a meta-analysis of randomized controlled trials reported decreased risk of fracture among DPP-IVi users. However, the mean trial duration of the studies in the meta-analysis is only 35 weeks; thus the potential fracture reduction is more likely to be due to a decrease in falls than an increase in bone quality (Monami et al. 2011). GLP-1 receptor agonists have shown neutral effects on fracture risk both in observational studies (Driessen et al. 2015a) and a meta-analysis of randomized controlled trials (Mabilleau et al. 2014). The SGLT-2 inhibitors have been proposed to increase fracture risk in patients with diabetes due to an increased osmotic diuresis and thereby loss of calcium. So far, studies performed have shown neutral effects although long-term treatment trials are needed to determine if there may be an effect (Palermo et al. 2015; Alba et al. 2016). Based on the current evidence, glitazone is the only glucose-lowering drug that has detrimental effects on the bone in patients with diabetes. All other glucose-lowering drugs show neutral effects. The increased fracture risk among patients with diabetes is therefore not explained by the use of glucose-lowering drugs.

## Lipid-Lowering Drugs

Among the lipid-lowering drugs, statins are the most commonly used. Statins inhibit the HMG-CoA reductase and thereby the cholesterol synthesis. Bisphosphonates, an antiresorptive drug class, affect the same pathway but at a later stage by inhibiting the synthesis of farnesyl pyrophosphate. Thus, it has been hypothesized that statins are potent antiresorptives. Furthermore, *in vitro* studies have shown positive effects on bone formation by statins (Bauer 2003). Statin treatment is associated with decreased C-terminal cross-linking telopeptide (CTX) levels but also decreased N-terminal propeptide of type 1 collagen (PINP) levels in patients with diabetes (Hernandez et al. 2013). These results have been followed by several observational studies that find a reduced fracture risk among users of statins even when compared

to other lipid-lowering drugs (Rejnmark et al. 2006; Toh and Hernandez-Diaz 2007). However, randomized controlled trials find neutral effects of statins on fracture risk, and therefore statins are at present to be regarded as neutral in terms of fracture. The new line of lipid-lowering drug, PCSK-9 inhibitors, is even more potent in lowering low-density lipoprotein (LDL) cholesterol and may reduce the risk of cardiovascular disease. Thus the PCSK-9 inhibitors may be used more commonly in the treatment of diabetes in the future. The PCSK-9 inhibitors decrease the degradation of the LDL receptor and thereby increase the number of LDL receptors (Elbitar et al. 2016). Both in vitro and murine models have shown that an LDL-receptor knockout genotype decreases osteoclast survival and activity and increases trabecular bone density compared to the wild type (Luegmayr et al. 2004; Okayasu et al. 2012). Thus an increased number of LDL receptors may increase osteoclast activity, bone resorption, and fracture risk. Observational studies are important to detect potential fracture risk increases related to the PCSK-9 inhibitors.

## Antihypertensives

Antihypertensives may increase fracture risk by inducing orthostatic hypotension that may cause falls and thereby fractures. Furthermore, diuretics may increase the amount of urinary calcium excretion. Loop diuretics but not thiazides have been associated with an increased risk of fracture in patients with diabetes (Starup-Linde et al. 2016b); however at present, antihypertensives are to be regarded as neutral in terms of fracture risk.

---

## Potential Predictors of Diabetic Bone Disease

Diabetes duration is a potential predictor of fracture in patients with diabetes. At the time of diabetes diagnosis and treatment start a rapid lowering of blood glucose, and an increased risk of hypoglycemia may increase fracture risk in patients with diabetes. Coherent to this, newly diagnosed patients with type 2 diabetes had an increased risk of fracture also when adjusted for previous falls (Martinez-Laguna et al. 2015), whereas longer diabetes duration is related to an increased formation of advanced glycation end products that may increase fracture risk (see the section “[Pathophysiology of Diabetic Bone Disease](#)”) (McCarty 1995). Observational studies have reported increased fracture risk with longer diabetes duration (Melton III et al. 2008; Viegas et al. 2011). Both mechanisms may apply in patients with diabetes, and therefore both a recent diagnosis and long-term diabetes may predict fracture risk.

## Comorbidities

In addition to diabetes duration, comorbidities may increase fracture risk and be a predictor of fracture risk among patients with diabetes. Type 3c diabetes, which is

exocrine pancreatitis deficiency causing diabetes, is suggested to make up 9% of the entire diabetes population (Hardt et al. 2008). These individuals also have malabsorption of minerals and vitamins, which are important for bone health (Sarles 1992). It is not routinely examined if a subject suffers specifically from type 3c diabetes, and it is unknown whether this type of diabetes may explain a larger number of fractures. However, pancreatitis per se is associated with a 3.5-fold increased risk of hip fracture (Munigala et al. 2015). Studies determining the influence of pancreatitis on fracture risk in diabetes are needed. Other comorbidities that may influence and predict fracture are autoimmune diseases. Type 1 diabetes is associated with an increased risk of thyroid disease and celiac disease (Witek et al. 2012). Thyroid disease is related to an altered bone turnover and celiac disease to malabsorption and malnutrition. It is controversial whether celiac disease is related to fracture (Compston 2003), but thyroid disease is associated with and increased risk of fracture (Vestergaard and Mosekilde 2002). Theoretically, both thyroid disease and celiac disease may partly explain fracture risk among patients with type 1 diabetes. Further research is needed to determine the influence of comorbidities on fracture risk in patients with diabetes.

## Recent Scanning Modalities

Although the bone mineral density is a less useful predictor in patients with diabetes, more sophisticated data processing of the scans and new techniques may add to the prediction of fracture. Trabecular bone score is a further calculated variable that correlates with the number of trabeculae and spacing between trabeculae. The trabecular bone score may add to the value of the traditional X-ray absorptiometry scan. The trabecular bone score seems to be lower in patients with diabetes compared to controls and may detect deteriorations in bone architecture (Dhaliwal et al. 2014). However, another study finds similar trabecular bone scores in patients with and without diabetes (Kim et al. 2015). Furthermore, among patients with diabetes, the trabecular bone score is associated with HbA1c, thus linking bone architecture and glucose metabolism. Trabecular bone score has proved superior to bone mineral density in predicting fracture risk among women with diabetes (Leslie et al. 2013). Although the current evidence is limited, trabecular bone score has the potential to be a stronger fracture predictor than bone mineral density measurements among patients with diabetes.

The high-resolution peripheral quantitative computed tomography scan is a recent scanning technique that creates images in resolutions of 78  $\mu\text{m}$ . The high resolution makes it possible to grade cortical and trabecular bone. However, the technique only allows scanning of peripheral bone (tibia and radius) (Cheung et al. 2013). The scan enables a calculation of the volumetric bone mineral density, whereas the dual energy X-ray absorptiometry scan quantifies the areal bone mineral density. The volumetric bone mineral density does not differ between patients with type 2 diabetes and nondiabetes individuals (Farr et al. 2014; Shu et al. 2012). Furthermore, the technique quantifies the size and number of pores in cortical bone

(cortical porosity) but may also estimate the strength of the bone by the finite element analysis. Greater cortical porosity and cortical pore size at the radius and tibia have been observed among patients with type 2 diabetes with a fracture compared to patients without a fracture (Patsch et al. 2013). Furthermore, increased cortical porosity and cortical pore size are observed among patients with diabetes (Heilmeier et al. 2016; Paccou et al. 2016); however, no differences in these parameters have also been observed between patients with diabetes and controls (Farr et al. 2014; Shu et al. 2012; Patsch et al. 2013). This may be explained by the fact that both patients with type 1 and type 2 diabetes with microvascular disease show altered cortical bone structure compared to patients with diabetes without microvascular disease (Shanbhogue et al. 2015a, 2015b). This suggests that cortical deficits in diabetes are a cause of microvascular disease and microangiopathy. The high-resolution peripheral quantitative computed tomography scan only presents few differences between patients with type 1 and type 2 diabetes (Starup-Linde et al. 2016c), suggesting that bone microstructure is similar between the two diabetes types and that similar mechanisms apply for bone deficiencies in these patients. At present, the high-resolution peripheral quantitative computed tomography scan may be a possible predictor of fracture in patients with diabetes with special promise for the cortical porosity. However, observational studies examining the relation to incident hip fractures are needed to determine whether cortical porosity is a reliable predictor of fracture. Other scanning techniques as the quantitative computed tomography and the magnetic resonance imaging can determine bone structure but have only been used to a limited extent. Interestingly, patients with type 1 diabetes show increased trabecular spacing assessed by magnetic resonance imaging that is related to microvascular complications. However, microvascular disease is not associated with an increased fracture risk (Vestergaard et al. 2009) even though microstructural deficits are related to microvascular disease among patients with diabetes (Abdalrahman et al. 2015).

## Microindentation

Besides noninvasive scanning techniques, the invasive microindentation that quantifies bone material strength by penetrating the bone cortical compartment may be a potential fracture predictor. Bone material strength is decreased among patients with type 2 diabetes compared to controls and inversely correlated to HbA1c (Farr et al. 2014). This technique may directly quantify decreases in bone strength as observed by cortical deficits in the scanning techniques.

## Bone Turnover Markers

Other potential predictors of fracture include markers of bone turnover. Decreased levels of the osteoblast marker, osteocalcin, are associated with fracture in patients with diabetes (Kanazawa et al. 2011). Furthermore, increased levels of sclerostin in

patients with type 2 diabetes and decreased levels of sclerostin in patients with type 1 diabetes are associated with increased risk of fractures (Starup-Linde et al. 2016c; Ardawi et al. 2013; Yamamoto et al. 2013). Sclerostin is an inhibitor of bone formation. Bone formation is higher among patients with type 1 diabetes compared to patients with type 2 diabetes (Starup-Linde et al. 2016d), which may explain the opposite directions of fracture observed in the context of sclerostin. Increased levels may harmfully decrease bone formation in patients with type 2 diabetes. On the other hand, an increased bone formation (low sclerostin levels) may induce advanced glycation end products in patients with type 1 diabetes that increase bone fragility. Diabetes is a state of low bone turnover and it is therefore plausible that bone turnover markers may be fracture predictors; however, larger observational studies are needed to confirm these findings.

---

## Diagnostic Approach to Diabetic Bone Disease

Currently no guidelines exist for the diagnostic approach to diabetic bone disease. Large difficulties remain as diabetes is a condition where diabetes per se, comorbidities, medication, and lifestyle all may influence bone health. Factors that affect fracture risk in patients with diabetes are displayed in Fig. 2.

First of all, patients at the risk of diabetic bone disease need to be identified. As for classical osteoporosis, a previous fracture is a main predictor of fracture. Furthermore, patients reporting a loss of height may have a prevalent vertebral fracture. Patients identified at risk of diabetic bone disease should be screened for classical osteoporosis by a clinical examination and interview. Furthermore, symptoms of malabsorption should be investigated thoroughly as this may be caused by celiac disease or an undetected pancreatitis. Patients should be interviewed regarding genetic disposition, history of falls, hypoglycemic episodes, and orthostatic hypotension as fall prevention or changes in glucose-lowering and antihypertensive therapies may be indicated. For patients using glitazones, the increased risk of fractures should be taken into account and may result in discontinuation. A classical dual energy X-ray absorptiometry is still the primary diagnostic tool and indicated to determine bone mineral density as primary osteoporosis may be present in patients with diabetes. Individuals with a hip fracture or loss of height should be examined by an X-ray of the spine to detect prevalent fractures. Blood tests should be used to detect signs of secondary osteoporosis as osteomalacia, thyroid disease, hyperparathyroidism, and malignancies. Quantifications of bone resorption and bone formation by CTX and P1NP may be of clinical use. Very low levels of CTX may be a contraindication of antiresorptive therapies. CTX and P1NP markers may be followed for treatment effects. Bone tissue biopsies, microindentation, other blood tests, and other non-invasive scanning techniques to detect cortical deficiencies may for research purposes follow the initial investigations. Table 2 shows the suggested diagnostic approach to diabetic bone disease.

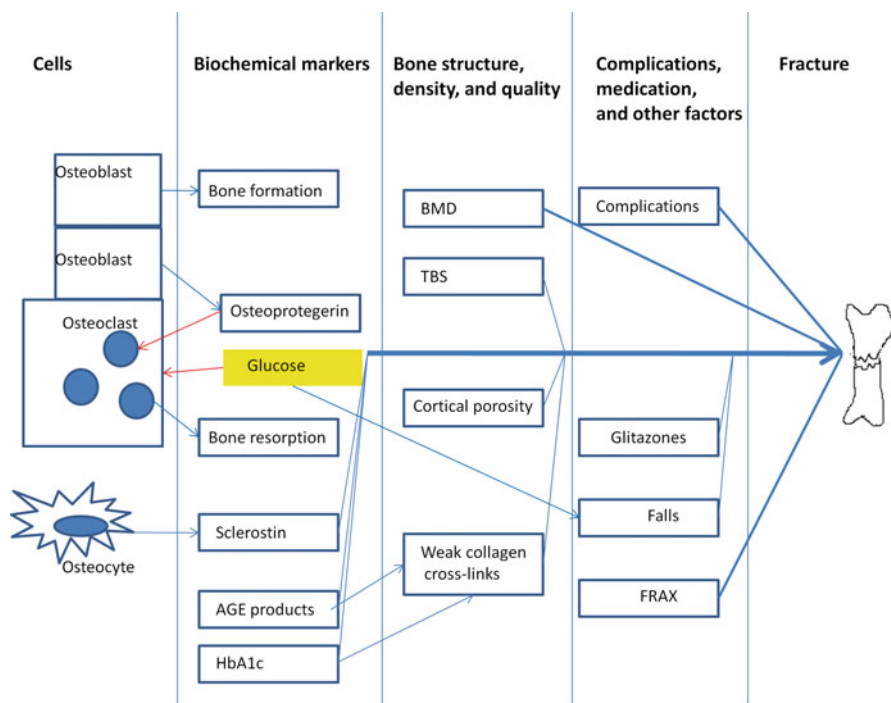

**Fig. 2** Factors that influence the risk of fracture in patients with diabetes. Hyperglycemia may increase fracture risk directly by lowering bone turnover or indirectly by the formation of advanced glycation end products and weak collagen cross-links. *OPG* osteoprotegerin, *AGE* advanced glycation end products, *TBS* trabecular bone score, *BMD* bone mineral density, *FRAX* Fracture Risk Assessment Tool. Blue arrows indicate relationships. Red arrows indicate inhibitory effects. (Adapted from Starup-Linde (2015) with permission from the author)

**Table 2** Suggestion of diagnostic approach to diabetic bone disease

1. Examine patients with a previous fracture of hip, vertebra, or wrist  
Patients with diabetes reporting loss of height should also be examined  
Patients with diabetes at risk of primary osteoporosis
2. Clinical examination and interview on malabsorption symptoms (diarrhea, weight loss, white-colored feces, symptoms of vitamin or mineral deficiency), comorbid conditions, and predictors of classical osteoporosis
3. Focus on falls and hypoglycemic events. Previous falls?
4. Does the patient use glitazones?
5. Dual energy X-ray absorptiometry. Is the bone mineral density low?
6. X-ray of the spine. Are there any prevalent vertebral fractures?
7. Blood tests for secondary causes of osteoporosis including CTX and PINP to quantify bone turnover. Osteomalacia, thyroid disease, hyperparathyroidism?
8. For research purpose: Bone tissue biopsy, bone microindentation, high-resolution peripheral quantitative computed tomography scan, and further markers of bone signaling (e.g., sclerostin)

## Treatment of Diabetic Bone Disease

Calcium and vitamin D are the prophylactic treatment of osteoporosis and should also be used in patients with diabetes. Diabetes individuals are more susceptible to low vitamin D levels perhaps due to obesity and larger volume of distribution (Starup-Linde et al. 2014). The guidelines for calcium and vitamin D doses vary from country to country. In primary osteoporosis, calcium and vitamin D treatment is supplemented by anti-osteoporotic treatment. Most commonly used are the anti-resorptive drugs. The bisphosphonate is an antiresorptive drug that inhibits osteoclast activity with long-term effect. In patients with diabetes, bone mineral density increases and resorption markers decrease during bisphosphonate treatment (Keegan et al. 2004). An observational study showed no difference in fracture rates between patients with and without diabetes treated with bisphosphonates. The fracture rates were also similar when comparing patients with type 1 and type 2 diabetes treated with bisphosphonates (Vestergaard et al. 2011). Bisphosphonates and other anti-resorptives thus seem to be safe in patients with diabetes; however, within the observational study, the patients with diabetes are most likely to be treated for primary osteoporosis. The fact that diabetes is a state of low bone turnover and may represent some degree of adynamic bone disease may question the use of antiresorptives. It is unknown whether patients with diabetes with very low bone turnover benefit from antiresorptive treatment. Measurements of CTX and PINP may determine which patients would benefit from antiresorptive treatment. Denosumab is a more recently developed antiresorptive that reversibly inhibits osteoclast activity; however, discontinuation reactivates the osteoclasts and causes resorption of the bone to a larger extent than before initiation (Bone et al. 2011). It is unknown whether denosumab is beneficial in diabetic bone disease. Treatment with parathyroid hormone, teriparatide, is an anabolic treatment of osteoporosis (Ferrari 2015). Since diabetes is a state of low bone turnover, teriparatide may theoretically reverse this to normal and be beneficial, but on the other hand, it may also increase the incorporation of advanced glycation end products which would increase bone fragility. Currently it is unknown whether teriparatide is beneficial in diabetic bone disease although similar reductions in non-vertebral fractures have been observed in patients with and without type 2 diabetes (Schwartz et al. 2016). Sclerostin antibodies are under development as a new class of anti-osteoporotic drugs (Clarke 2014). As sclerostin levels seem to be increased in patients with type 2 diabetes and are associated with fracture in these patients, this may become the drug of choice. However, caution should be made when applied to patients with type 1 diabetes because low levels of sclerostin are associated with an increased risk of fracture. However, no treatment trials have been conducted in patients with diabetes at the present. In patients with diabetes with fractures and nonclassical osteoporosis, it is currently unknown which treatment strategy should be used. Antiresorptives are to be regarded as safe although very limited evidence is available. Further studies investigating the effect of anti-osteoporotic treatment in patients with diabetes are needed.

---

## Future Perspectives

Much is known on the epidemiology of fracture in patients with diabetes; however, diabetes is entangled in medication, complications, and comorbidities. Although difficult, it is important to disentangle the effects of the separate factors. Little is known on the effect of the specific glucose-lowering drugs on fracture risk, and further research with randomized controlled trials is needed.

There is currently no well-performing predictor of fracture in patients with diabetes. The most promising novel fracture predictors are the trabecular bone score, cortical porosity, bone material strength, and measurement of circulating sclerostin levels or a combined risk factor algorithm; however, further research is needed. Little is known on the treatment of diabetic bone disease, and randomized controlled trials are needed to evaluate the effect of specific anti-osteoporotic drugs.

---

## Implications

Diabetes should be regarded as a condition with an increased fracture risk. Focus on detecting diabetic bone disease is important in the clinic besides the usual glycemic control and screening for cardiovascular disease risk and microvascular disease. However, current predictors of fractures underestimate the fracture risk in patients with diabetes, and thus, it is important to detect patients with previous significant fractures including undetected vertebral fractures. When applying treatment for diabetic bone disease, the evidence is poor. Fall prophylaxis is essential, and thus detecting hypoglycemia, orthostatic hypotension, and other factors that increase the risk of falls is important. Presently bisphosphonates seem to be the best choice, and before treatment starts, measurement of CTX and P1NP may confirm the indication for treatment.

---

## Summary

Diabetes mellitus is associated with an increased risk of fractures. The increased fracture risk is not solely explained by a decreased bone mineral density, use of pharmaceuticals, or increased number of falls. Diabetic bone disease may be an adynamic bone disease with a low bone turnover as well as glycosylation of bone collagen. It is known that use of glitazones increases the fracture risk and discontinuation is beneficial in terms of bone health. X-ray of the spine may detect prevalent vertebral fractures and should be used routinely to detect diabetic bone disease. Current evidence is sparse on the effect of antidiabetics and anti-osteoporotic treatments; however, they should be regarded to be safe.



## Cross-References

- ▶ [Diabetes and Obesity](#)
- ▶ [Diabetes Secondary to Pancreatic Diseases](#)
- ▶ [Hypoglycemia](#)
- ▶ [Pathogenesis of Microvascular Complications](#)

---

## References

- Abdalrahman N, McComb C, Foster J, et al. Deficits in trabecular bone microarchitecture in young women with type 1 diabetes mellitus. *J Bone Miner Res*. 2015;30(8):1386–93. <https://doi.org/10.1002/jbmr.2465>.
- Alba M, Xie J, Fung A, et al. The effects of canagliflozin, a sodium glucose co-transporter 2 inhibitor, on mineral metabolism and bone in patients with type 2 diabetes mellitus. *Curr Med Res Opin*. 2016;32(8):1375–85. <https://doi.org/10.1080/03007995.2016.1174841>.
- American Diabetes Association. Diagnosis and classification of diabetes mellitus. *Diabetes Care*. 2012;35(Suppl 1):S64–71. <https://doi.org/10.2337/dc12-s064>.
- Ardawi MS, Akhbar DH, Alshaikh A, et al. Increased serum sclerostin and decreased serum IGF-1 are associated with vertebral fractures among postmenopausal women with type-2 diabetes. *Bone*. 2013;56(2):355–62. <https://doi.org/10.1016/j.bone.2013.06.029>.
- Armas LA, Akhter MP, Drincic A, et al. Trabecular bone histomorphometry in humans with type 1 diabetes mellitus. *Bone*. 2012;50(1):91–6. <https://doi.org/10.1016/j.bone.2011.09.055>.
- Basu R, Peterson J, Rizza R, et al. Effects of physiological variations in circulating insulin levels on bone turnover in humans. *J Clin Endocrinol Metab*. 2011;96(5):1450–5.
- Bauer DC. HMG CoA reductase inhibitors and the skeleton: a comprehensive review. *Osteoporos Int*. 2003;14(4):273–82. <https://doi.org/10.1007/s00198-002-1323-x>.
- Bjarnason NH, Henriksen EE, Alexandersen P, et al. Mechanism of circadian variation in bone resorption. *Bone*. 2002;30(1):307–13. [https://doi.org/10.1016/S8756-3282\(01\)00662-7](https://doi.org/10.1016/S8756-3282(01)00662-7).
- Bollag RJ, Zhong Q, Phillips P, et al. Osteoblast-derived cells express functional glucose-dependent insulinotropic peptide receptors. *Endocrinology*. 2000;141(3):1228–35. <https://doi.org/10.1210/endo.141.3.7366>.
- Bonds DE, Larson JC, Schwartz AV, et al. Risk of fracture in women with type 2 diabetes: the women's health initiative observational study. *J Clin Endocrinol Metab*. 2006;91(9):3404–10. <https://doi.org/10.1210/jc.2006-0614>.
- Bone HG, Bolognese MA, Yuen CK, et al. Effects of denosumab treatment and discontinuation on bone mineral density and bone turnover markers in postmenopausal women with low bone mass. *J Clin Endocrinol Metab*. 2011;96(4):972–80. <https://doi.org/10.1210/jc.2010-1502>.
- Bonewald LF. The amazing osteocyte. *J Bone Miner Res*. 2011;26(2):229–38. <https://doi.org/10.1002/jbmr.320>.
- Boyle WJ, Simonet WS, Lacey DL. Osteoclast differentiation and activation. *Nature*. 2003;423(6937):337–42. <https://doi.org/10.1038/nature01658>.
- Brunton SA. Nocturnal hypoglycemia: answering the challenge with long-acting insulin analogs. *Med Gen Med*. 2007;9(2):38.
- Canalis E, Mazzziotti G, Giustina A, et al. Glucocorticoid-induced osteoporosis: pathophysiology and therapy. *Osteoporos Int*. 2007;18(10):1319–28. <https://doi.org/10.1007/s00198-007-0394-0>.
- Carlsson S, Hammar N, Grill V, et al. Alcohol consumption and the incidence of type 2 diabetes: a 20-year follow-up of the finnish twin cohort study. *Diabetes Care*. 2003;26(10):2785–90.
- Chailurkit LO, Chanprasertyothin S, Rajatanavin R, et al. Reduced attenuation of bone resorption after oral glucose in type 2 diabetes. *Clin Endocrinol*. 2008;68(6):858–62. <https://doi.org/10.1111/j.1365-2265.2007.03159.x>.

- Chapman IM. Obesity paradox during aging. *Interdiscip Top Gerontol*. 2010;37:20–36. <https://doi.org/10.1159/000319992>.
- Cheung AM, Adachi JD, Hanley DA, et al. High-resolution peripheral quantitative computed tomography for the assessment of bone strength and structure: a review by the Canadian bone strength working group. *Curr Osteoporos Rep*. 2013;11(2):136–46. <https://doi.org/10.1007/s11914-013-0140-9>.
- Clarke BL. Anti-sclerostin antibodies: utility in treatment of osteoporosis. *Maturitas*. 2014;78(3):199–204.
- Clowes JA, Allen HC, Prentis DM, et al. Octreotide abolishes the acute decrease in bone turnover in response to oral glucose. *J Clin Endocrinol Metab*. 2003;88(10):4867–73. <https://doi.org/10.1210/jc.2002-021447>.
- Colhoun HM, Livingstone SJ, Looker HC, et al. Hospitalised hip fracture risk with rosiglitazone and pioglitazone use compared with other glucose-lowering drugs. *Diabetologia*. 2012;55(11):2929–37. <https://doi.org/10.1007/s00125-012-2668-0>.
- Compston J. Is fracture risk increased in patients with coeliac disease? *Gut*. 2003;52(4):459–60.
- Conway BN, Long DM, Figaro MK, et al. Glycemic control and fracture risk in elderly patients with diabetes. *Diabetes Res Clin Pract*. 2016;115:47–53. <https://doi.org/10.1016/j.diabres.2016.03.009>.
- Dhaliwal R, Cibula D, Ghosh C, et al. Bone quality assessment in type 2 diabetes mellitus. *Osteoporos Int*. 2014;25(7):1969–73. <https://doi.org/10.1007/s00198-014-2704-7>.
- Driessen JH, van Onzenoort HA, Starup-Linde J, et al. Use of glucagon-like-peptide 1 receptor agonists and risk of fracture as compared to use of other anti-hyperglycemic drugs. *Calcif Tissue Int*. 2015a;97(5):506–15. <https://doi.org/10.1007/s00223-015-0037-y>.
- Driessen JH, van Onzenoort HA, Starup-Linde J, et al. Use of dipeptidyl peptidase 4 inhibitors and fracture risk compared to use of other anti-hyperglycemic drugs. *Pharmacoeconom Drug Saf*. 2015b;24(10):1017–25. <https://doi.org/10.1002/pds.3837>.
- Elbitar S, Khoury PE, Ghaleb Y, et al. Proprotein convertase subtilisin / kexin 9 (PCSK9) inhibitors and the future of dyslipidemia therapy: an updated patent review (2011–2015). *Expert Opin Ther Pat*. 2016;26(12):1377–92. <https://doi.org/10.1080/13543776.2016.1206080>.
- Esser N, Legrand-Poels S, Piette J, et al. Inflammation as a link between obesity, metabolic syndrome and type 2 diabetes. *Diabetes Res Clin Pract*. 2014;105(2):141–50. <https://doi.org/10.1016/j.diabres.2014.04.006>.
- Fan Y, Wei F, Lang Y, et al. Diabetes mellitus and risk of hip fractures: a meta-analysis. *Osteoporos Int*. 2015;27(1):219–28. <https://doi.org/10.1007/s00198-015-3279-7>.
- Farr JN, Drake MT, Amin S, et al. In vivo assessment of bone quality in postmenopausal women with type 2 diabetes. *J Bone Miner Res*. 2014;29(4):787–95. <https://doi.org/10.1002/jbmr.2106>.
- Ferrari S. Sequential/combined therapies in osteoporosis. *Osteoporos Int*. 2015;26(1):S65.
- Foy CG, Bell RA, Farmer DF, et al. Smoking and incidence of diabetes among U.S. adults: findings from the insulin resistance atherosclerosis study. *Diabetes Care*. 2005;28(10):2501–7. <https://doi.org/10.2337/diacare.28.10.2501>.
- Furst JR, Bandeira LC, Fan WW, et al. Advanced glycation endproducts and bone material strength in type 2 diabetes. *J Clin Endocrinol Metab*. 2016;101(6):2502–10. <https://doi.org/10.1210/jc.2016-1437>.
- Garcia-Hernandez A, Arzate H, Gil-Chavarria I, et al. High glucose concentrations alter the biomineralization process in human osteoblastic cells. *Bone*. 2012;50(1):276–88. <https://doi.org/10.1016/j.bone.2011.10.032>.
- Giangregorio LM, Leslie WD, Lix LM, et al. FRAX underestimates fracture risk in patients with diabetes. *J Bone Miner Res*. 2012;27(2):301–8. <https://doi.org/10.1002/jbmr.556>.
- Gimble JM, Zvonice S, Floyd ZE, et al. Playing with bone and fat. *J Cell Biochem*. 2006;98(2):251–66. <https://doi.org/10.1002/jcb.20777>.
- Hall JE, Guyton AC. *Guyton and hall textbook of medical physiology*. 12th ed. Philadelphia: Saunders/Elsevier; 2011.
- Hardt PD, Brendel MD, Kloer HU, et al. Is pancreatic diabetes (type 3c diabetes) underdiagnosed and misdiagnosed? *Diabetes Care*. 2008;31(Suppl 2):S165–9. <https://doi.org/10.2337/dc08-s244>.

- Hasseriis R, Karlsson MK, Jonsson B, et al. Long-term morbidity and mortality after a clinically diagnosed vertebral fracture in the elderly – a 12- and 22-year follow-up of 257 patients. *Calcif Tissue Int.* 2005;76(4):235–42. <https://doi.org/10.1007/s00223-004-2222-2>.
- Heilmeyer U, Cheng K, Pasco C, et al. Cortical bone laminar analysis reveals increased midcortical and periosteal porosity in type 2 diabetic postmenopausal women with history of fragility fractures compared to fracture-free diabetics. *Osteoporos Int.* 2016;27(9):2791–802. <https://doi.org/10.1007/s00198-016-3614-7>.
- Henriksen DB, Alexandersen P, Bjarnason NH, et al. Role of gastrointestinal hormones in post-prandial reduction of bone resorption. *J Bone Miner Res.* 2003;18(12):2180–9. <https://doi.org/10.1359/jbmr.2003.18.12.2180>.
- Hernandez JL, Olmos JM, Romana G, et al. Bone turnover markers in statin users: a population-based analysis from the Camargo cohort study. *Maturitas.* 2013;75(1):67–73. <https://doi.org/10.1016/j.maturitas.2013.02.003>.
- Herrera A, Mateo J, Gil-Albarova J, et al. Prevalence of osteoporotic vertebral fracture in spanish women over age 45. *Maturitas.* 2015;80(3):288–95. <https://doi.org/10.1016/j.maturitas.2014.12.004>.
- Holst JJ, Knop FK, Vilsboll T, et al. Loss of incretin effect is a specific, important, and early characteristic of type 2 diabetes. *Diabetes Care.* 2011;34(Suppl 2):S251–7. <https://doi.org/10.2337/dc11-s227>.
- Hwang JL, Weiss RE. Steroid-induced diabetes: a clinical and molecular approach to understanding and treatment. *Diabetes Metab Res Rev.* 2014;30(2):96–102. <https://doi.org/10.1002/dmrr.2486>.
- Imai Y, Youn MY, Inoue K, et al. Nuclear receptors in bone physiology and diseases. *Physiol Rev.* 2013;93(2):481–523. <https://doi.org/10.1152/physrev.00008.2012>.
- International Diabetes Federation. IDF diabetes atlas update. 2014. <http://www.idf.org/diabetesatlas/update-2014>. Accessed 10 Feb 2015.
- IOF. IOF epidemiology. 2015. <http://www.iofbonehealth.org/epidemiology>. Accessed 11 Feb 2015.
- Janghorbani M, van Dam RM, Willett WC, et al. Systematic review of type 1 and type 2 diabetes mellitus and risk of fracture. *Am J Epidemiol.* 2007;166(5):495–505. <https://doi.org/10.1093/aje/kwm106>.
- Kahn SE, Zinman B, Lachin JM, et al. Rosiglitazone-associated fractures in type 2 diabetes: an analysis from a diabetes outcome progression trial (ADOPT). *Diabetes Care.* 2008;31(5):845–51. <https://doi.org/10.2337/dc07-2270>.
- Kanazawa I, Yamaguchi T, Sugimoto T. Serum insulin-like growth factor-I is a marker for assessing the severity of vertebral fractures in postmenopausal women with type 2 diabetes mellitus. *Osteoporos Int.* 2011;22(4):1191–8. <https://doi.org/10.1007/s00198-010-1310-6>.
- Kanis JA, Johansson H, Johnell O, et al. Alcohol intake as a risk factor for fracture. *Osteoporos Int.* 2005a;16(7):737–42. <https://doi.org/10.1007/s00198-004-1734-y>.
- Kanis JA, Johnell O, Oden A, et al. Smoking and fracture risk: a meta-analysis. *Osteoporos Int.* 2005b;16(2):155–62. <https://doi.org/10.1007/s00198-004-1640-3>.
- Kannus P, Parkkari J, Niemi S, et al. Prevention of hip fracture in elderly people with use of a hip protector. *N Engl J Med.* 2000;343(21):1506–13. <https://doi.org/10.1056/NEJM200011233432101>.
- Keegan TH, Schwartz AV, Bauer DC, et al. Effect of alendronate on bone mineral density and biochemical markers of bone turnover in type 2 diabetic women: the fracture intervention trial. *Diabetes Care.* 2004;27(7):1547–53. <https://doi.org/10.2337/diacare.27.7.1547>.
- Khosla S. Minireview: the OPG/RANKL/RANK system. *Endocrinology.* 2001;142(12):5050–5. <https://doi.org/10.1210/endo.142.12.8536>.
- Khosla S, Riggs BL. Pathophysiology of age-related bone loss and osteoporosis. *Endocrinol Metab Clin N Am.* 2005;34(4):1015–30. <https://doi.org/10.1016/j.ecl.2005.07.009>.
- Kim JH, Choi HJ, Ku EJ, et al. Trabecular bone score as an indicator for skeletal deterioration in diabetes. *J Clin Endocrinol Metab.* 2015;100(2):475–82. <https://doi.org/10.1210/jc.2014-2047>.
- Kiyohara N, Yamamoto M, Sugimoto T. Discordance between prevalent vertebral fracture and vertebral strength estimated by the finite element method based on quantitative computed tomography in patients with type 2 diabetes mellitus. *PLoS One.* 2015;10(12):e0144496. <https://doi.org/10.1371/journal.pone.0144496>.

- Kostolanska J, Jakus V, Barak L. HbA1c and serum levels of advanced glycation and oxidation protein products in poorly and well controlled children and adolescents with type 1 diabetes mellitus. *J Pediatr Endocrinol Metab.* 2009;22(5):433–42.
- Krakauer JC, McKenna MJ, Buderer NF, et al. Bone loss and bone turnover in diabetes. *Diabetes.* 1995;44(7):775–82.
- Lapane KL, Yang S, Brown MJ, et al. Sulfonylureas and risk of falls and fractures: a systematic review. *Drugs Aging.* 2013;30(7):527–47. <https://doi.org/10.1007/s40266-013-0081-0>.
- Lecka-Czernik B. PPARs in bone: the role in bone cell differentiation and regulation of energy metabolism. *Curr Osteoporosis Rep.* 2010;8(2):84–90.
- Lecka-Czernik B, Rosen CJ, Kawai M. Skeletal aging and the adipocyte program: new insights from an “old” molecule. *Cell Cycle.* 2010;9(18):3648–54. <https://doi.org/10.1111/j.1749-6632.2009.05221.x>.
- Lee RH, Colon-Emeric C. Increased fracture risk among women with diabetes mellitus is mediated by increased falls propensity. *J Am Geriatr Soc.* 2014;62:S58.
- Leslie WD, Aubry-Rozier B, Lamy O, et al. TBS (trabecular bone score) and diabetes-related fracture risk. *J Clin Endocrinol Metab.* 2013;98(2):602–9. <https://doi.org/10.1210/jc.2012-3118>.
- Leslie WD, Morin SN, Lix LM, et al. Does diabetes modify the effect of FRAX risk factors for predicting major osteoporotic and hip fracture? *Osteoporos Int.* 2014;25(12):2817–24. <https://doi.org/10.1007/s00198-014-2822-2>.
- Li CI, Liu CS, Lin WY, et al. Glycated hemoglobin level and risk of hip fracture in older people with type 2 diabetes: a competing risk analysis of Taiwan diabetes cohort study. *J Bone Miner Res.* 2015;30(7):1338–46. <https://doi.org/10.1002/jbmr.2462>.
- Luegmayr E, Glantschnig H, Wesolowski GA, et al. Osteoclast formation, survival and morphology are highly dependent on exogenous cholesterol/lipoproteins. *Cell Death Differ.* 2004;11(Suppl 1):S108–18. <https://doi.org/10.1038/sj.cdd.4401399>.
- Mabilleau G, Mieczkowska A, Chappard D. Use of glucagon-like peptide-1 receptor agonists and bone fractures: a meta-analysis of randomized clinical trials. *J Diabetes.* 2014;6(3):260–6. <https://doi.org/10.1111/1753-0407.12102>.
- Manavalan JS, Cremers S, Dempster DW, et al. Circulating osteogenic precursor cells in type 2 diabetes mellitus. *J Clin Endocrinol Metab.* 2012;97(9):3240–50. <https://doi.org/10.1210/jc.2012-1546>.
- Martinez-Laguna D, Tebe C, Javaid MK, et al. Incident type 2 diabetes and hip fracture risk: a population-based matched cohort study. *Osteoporos Int.* 2015;26(2):827–33. <https://doi.org/10.1007/s00198-014-2986-9>.
- McCarty MF. Anabolic effects of insulin on bone suggest a role for chromium picolinate in preservation of bone density. *Med Hypotheses.* 1995;45(3):241–6. [https://doi.org/10.1016/0306-9877\(95\)90112-4](https://doi.org/10.1016/0306-9877(95)90112-4).
- Meier C, Schwartz AV, Egger A, et al. Effects of diabetes drugs on the skeleton. *Bone.* 2015;82:93–100. <https://doi.org/10.1016/j.bone.2015.04.026>.
- Melton LJ III, Atkinson EJ, Cooper C, et al. Vertebral fractures predict subsequent fractures. *Osteoporos Int.* 1999;10(3):214–21. <https://doi.org/10.1007/s001980050218>.
- Melton LJ III, Leibson CL, Achenbach SJ, et al. Fracture risk in type 2 diabetes: update of a population-based study. *J Bone Miner Res.* 2008;23(8):1334–42. <https://doi.org/10.1359/jbmr.080323>.
- Monami M, Dicembrini I, Antenore A, et al. Dipeptidyl peptidase-4 inhibitors and bone fractures: a meta-analysis of randomized clinical trials. *Diabetes Care.* 2011;34(11):2474–6. <https://doi.org/10.2337/dc11-1099>.
- Munigala S, Agarwal B, Gelrud A, et al. Chronic pancreatitis and fracture: a retrospective, population-based veterans administration study. *Pancreas.* 2015;45(3):355–61. <https://doi.org/10.1097/MPA.0000000000000381>.
- Napoli N, Strotmeyer ES, Ensrud KE, et al. Fracture risk in diabetic elderly men: the MrOS study. *Diabetologia.* 2014;57(10):2057–65. <https://doi.org/10.1007/s00125-014-3289-6>.
- Neumann T, Lodes S, Kastner B, et al. High serum pentosidine but not eSRAGE is associated with prevalent fractures in type 1 diabetes independent of bone mineral density and glycaemic control. *Osteoporos Int.* 2014;25(5):1527–33. <https://doi.org/10.1007/s00198-014-2631-7>.

- Nissen A, Christensen M, Knop FK, et al. Glucose-dependent insulinotropic polypeptide inhibits bone resorption in humans. *J Clin Endocrinol Metab.* 2014;99(11):E2325–9. <https://doi.org/10.1210/jc.2014-2547>.
- Okayasu M, Nakayachi M, Hayashida C, et al. Low-density lipoprotein receptor deficiency causes impaired osteoclastogenesis and increased bone mass in mice because of defect in osteoclastic cell-cell fusion. *J Biol Chem.* 2012;287(23):19229–41. <https://doi.org/10.1074/jbc.M111.323600>.
- Paccou J, Ward KA, Jameson KA, et al. Bone microarchitecture in men and women with diabetes: the importance of cortical porosity. *Calcif Tissue Int.* 2016;98(5):465–73. <https://doi.org/10.1007/s00223-015-0100-8>.
- Pacheco-Pantoja EL, Ranganath LR, Gallagher JA, et al. Receptors and effects of gut hormones in three osteoblastic cell lines. *BMC Physiol.* 2011;11:12. <https://doi.org/10.1186/1472-6793-11-12>.
- Palermo A, D’Onofrio L, Eastell R, et al. Oral anti-diabetic drugs and fracture risk, cut to the bone: safe or dangerous? A narrative review. *Osteoporos Int.* 2015;26(8):2073–89.
- Panula J, Pihlajamaki H, Mattila VM, et al. Mortality and cause of death in hip fracture patients aged 65 or older: a population-based study. *BMC Musculoskelet Disord.* 2011;12:105. <https://doi.org/10.1186/1471-2474-12-105>.
- Patsch JM, Burghardt AJ, Yap SP, et al. Increased cortical porosity in type 2 diabetic postmenopausal women with fragility fractures. *J Bone Miner Res.* 2013;28(2):313–24. <https://doi.org/10.1002/jbmr.1763>.
- Pierce AM, Lindskog S, Hammarstrom L. Osteoclasts: structure and function. *Electron Microsc Rev.* 1991;4(1):1–45.
- Pscherer S, Kostev K, Dippel FW, et al. Fracture risk in patients with type 2 diabetes under different antidiabetic treatment regimens: a retrospective database analysis in primary care. *Diabetes Metab Syndr Obes.* 2016;9:17–23. <https://doi.org/10.2147/DMSO.S101370>.
- Rajpathak SN, Fu C, Brodovicz KG, et al. Sulfonylurea use and risk of hip fractures among elderly men and women with type 2 diabetes. *Drugs Aging.* 2015;32(4):321–7. <https://doi.org/10.1007/s40266-015-0254-0>.
- Rejnmark L, Vestergaard P, Mosekilde L. Statin but not non-statin lipid-lowering drugs decrease fracture risk: a nation-wide case-control study. *Calcif Tissue Int.* 2006;79(1):27–36. <https://doi.org/10.1007/s00223-006-0024-4>.
- Rubin MR, Paschalis EP, Poundarik A, et al. Advanced glycation endproducts and bone material properties in type 1 diabetic mice. *PLoS One.* 2016;11(5):e0154700. <https://doi.org/10.1371/journal.pone.0154700>.
- Saito M, Kida Y, Kato S, et al. Diabetes, collagen, and bone quality. *Curr Osteoporosis Rep.* 2014;12(2):181–8.
- Santesso N, Carrasco-Labra A, Brignardello-Petersen R. Hip protectors for preventing hip fractures in older people. *Cochrane Database Syst Rev.* 2014;3:CD001255. <https://doi.org/10.1002/14651858.CD001255.pub5>.
- Sarles H. Chronic pancreatitis and diabetes. *Bailliere Clin Endocrinol Metab.* 1992;6(4):745–75.
- Schwartz AV, Sellmeyer DE, Ensrud KE, et al. Older women with diabetes have an increased risk of fracture: a prospective study. *J Clin Endocrinol Metab.* 2001;86(1):32–8. <https://doi.org/10.1210/jcem.86.1.7139>.
- Schwartz AV, Vittinghoff E, Bauer DC, et al. Association of BMD and FRAX score with risk of fracture in older adults with type 2 diabetes. *JAMA.* 2011;305(21):2184–92. <https://doi.org/10.1001/jama.2011.715>.
- Schwartz AV, Margolis KL, Sellmeyer DE, et al. Intensive glycemic control is not associated with fractures or falls in the ACCORD randomized trial. *Diabetes Care.* 2012;35(7):1525–31. <https://doi.org/10.2337/dc11-2184>.
- Schwartz AV, Pavo I, Alam J, et al. Teriparatide in patients with osteoporosis and type 2 diabetes. *Bone.* 2016;91:152–8. <https://doi.org/10.1016/j.bone.2016.06.017>.
- Shah VN, Shah CS, Snell-Bergeon JK. Type 1 diabetes and risk of fracture: meta-analysis and review of the literature. *Diabet Med.* 2015;32(9):1134–42. <https://doi.org/10.1111/dme.12734>.

- Shanbhogue VV, Hansen S, Frost M, et al. Bone geometry, volumetric density, microarchitecture, and estimated bone strength assessed by HR-pQCT in adult patients with type 1 diabetes mellitus. *J Bone Miner Res.* 2015a;30(12):2188–99. <https://doi.org/10.1002/jbmr.2573>.
- Shanbhogue VV, Hansen S, Frost M, et al. Compromised cortical bone compartment in type 2 diabetes mellitus patients with microvascular disease. *Eur J Endocrinol.* 2015b;174(2):115–24. <https://doi.org/10.1530/EJE-15-0860>.
- Shu A, Yin MT, Stein E, et al. Bone structure and turnover in type 2 diabetes mellitus. *Osteoporos Int.* 2012;23(2):635–41. <https://doi.org/10.1007/s00198-011-1595-0>.
- Starup-Linde J. Investigations of diabetic bone disease: literature, registry, and clinical studies [Dissertation]. Aalborg: VBN, Aalborg University, The Faculty of Medicine, Department of Clinical Medicine (Videnbasen for Aalborg Universitet Aalborg Universitet, Det Sundhedsvidenskabelige Fakultet Klinisk Institute); 2015.
- Starup-Linde J, Vestergaard P. Biochemical bone turnover markers in diabetes mellitus - a systematic review. *Bone.* 2016;82:69–78. <https://doi.org/10.1016/j.bone.2015.02.019>.
- Starup-Linde J, Eriksen SA, Lykkeboe S, et al. Biochemical markers of bone turnover in diabetes patients – a meta-analysis, and a methodological study on the effects of glucose on bone markers. *Osteoporos Int.* 2014;25(6):1697–708.
- Starup-Linde J, Frost M, Vestergaard P, et al. Epidemiology of fractures in diabetes. *Calcif Tissue Int.* 2016a;100(2):109–21. <https://doi.org/10.1007/s00223-016-0175-x>.
- Starup-Linde J, Gregersen S, Vestergaard P. Associations with fracture in patients with diabetes: a nested case-control study. *BMJ Open.* 2016b;6(2):e009686. <https://doi.org/10.1136/bmjopen-2015-009686>.
- Starup-Linde J, Lykkeboe S, Gregersen S, et al. Bone structure and predictors of fracture in type 1 and type 2 diabetes. *J Clin Endocrinol Metab.* 2016c;101(3):928–36. <https://doi.org/10.1210/jc.2015-3882>.
- Starup-Linde J, Lykkeboe S, Gregersen S, et al. Differences in biochemical bone markers by diabetes type and the impact of glucose. *Bone.* 2016d;83:149–55. <https://doi.org/10.1016/j.bone.2015.11.004>.
- Tang X, Liu G, Kang J, et al. Obesity and risk of hip fracture in adults: a meta-analysis of prospective cohort studies. *PLoS One.* 2013;8(4):e55077. <https://doi.org/10.1371/journal.pone.0055077>.
- Toh S, Hernandez-Diaz S. Statins and fracture risk. A systematic review. *Pharmacoepidemiol Drug Saf.* 2007;16(6):627–40. <https://doi.org/10.1002/pds.1363>.
- Torekov SS, Iepsen EW, Lundgren J, et al. Treatment with a GLP-1 receptor agonist increases bone formation markers and prevents bone loss during weight loss maintenance in weight-reduced obese. *Diabetes.* 2015;64:A43.
- van Lierop AH, Hamdy NA, van der Meer RW, et al. Distinct effects of pioglitazone and metformin on circulating sclerostin and biochemical markers of bone turnover in men with type 2 diabetes mellitus. *Eur J Endocrinol.* 2012;166(4):711–6. <https://doi.org/10.1530/EJE-11-1061>.
- Vestergaard P. Discrepancies in bone mineral density and fracture risk in patients with type 1 and type 2 diabetes—a meta-analysis. *Osteoporos Int.* 2007;18(4):427–44. <https://doi.org/10.1007/s00198-006-0253-4>.
- Vestergaard P, Mosekilde L. Fractures in patients with hyperthyroidism and hypothyroidism: a nationwide follow-up study in 16,249 patients. *Thyroid.* 2002;12(5):411–9. <https://doi.org/10.1089/105072502760043503>.
- Vestergaard P, Rejnmark L, Mosekilde L. Relative fracture risk in patients with diabetes mellitus, and the impact of insulin and oral antidiabetic medication on relative fracture risk. *Diabetologia.* 2005;48(7):1292–9. <https://doi.org/10.1007/s00125-005-1786-3>.
- Vestergaard P, Rejnmark L, Mosekilde L. Diabetes and its complications and their relationship with risk of fractures in type 1 and 2 diabetes. *Calcif Tissue Int.* 2009;84(1):45–55. <https://doi.org/10.1007/s00223-008-9195-5>.
- Vestergaard P, Rejnmark L, Mosekilde L. Are antiresorptive drugs effective against fractures in patients with diabetes? *Calcif Tissue Int.* 2011;88(3):209–14.

- Viegas M, Costa C, Lopes A, et al. Prevalence of osteoporosis and vertebral fractures in postmenopausal women with type 2 diabetes mellitus and their relationship with duration of the disease and chronic complications. *J Diabetes Complicat.* 2011;25(4):216–21. <https://doi.org/10.1016/j.jdiacomp.2011.02.004>.
- Waterloo S, Ahmed LA, Center JR, et al. Prevalence of vertebral fractures in women and men in the population-based tromso study. *BMC Musculoskelet Disord.* 2012;13:3. <https://doi.org/10.1186/1471-2474-13-3>.
- Weber DR, Haynes K, Leonard MB, et al. Type 1 diabetes is associated with an increased risk of fracture across the life span: a population-based cohort study using the health improvement network (THIN). *Diabetes Care.* 2015;38(10):1913–20. <https://doi.org/10.2337/dc15-0783>.
- Witek PR, Witek J, Pankowska E. Type 1 diabetes-associated autoimmune diseases: screening, diagnostic principles and management. *Med Wieku Rozwoj.* 2012;16(1):23–34.
- Xie D, Cheng H, Hamrick M, et al. Glucose-dependent insulinotropic polypeptide receptor knock-out mice have altered bone turnover. *Bone.* 2005;37(6):759–69. <https://doi.org/10.1016/j.bone.2005.06.021>.
- Xie D, Zhong Q, Ding KH, et al. Glucose-dependent insulinotropic peptide-overexpressing transgenic mice have increased bone mass. *Bone.* 2007;40(5):1352–60. <https://doi.org/10.1016/j.bone.2007.01.007>.
- Xu J, Yue F, Wang J, et al. High glucose inhibits receptor activator of nuclear factor $\kappa$ B ligand-induced osteoclast differentiation via downregulation of vATPase V0 subunit d2 and dendritic cell-specific transmembrane protein. *Mol Med Rep.* 2014;11(2):865–70.
- Xu J, Yue F, Wang J, et al. High glucose inhibits receptor activator of nuclear factor $\kappa$ B ligand-induced osteoclast differentiation via downregulation of vATPase V0 subunit d2 and dendritic cell-specific transmembrane protein. *Mol Med Rep.* 2015;11(2):865–70. <https://doi.org/10.3892/mmr.2014.2807>.
- Yamamoto M, Yamauchi M, Sugimoto T. Elevated sclerostin levels are associated with vertebral fractures in patients with type 2 diabetes mellitus. *J Clin Endocrinol Metab.* 2013;98(10):4030–7. <https://doi.org/10.1210/jc.2013-2143>.
- Yang X, Mostafa AJ, Appleford M, et al. Bone formation is affected by matrix advanced glycation end products (AGEs) in vivo. *Calcif Tissue Int.* 2016;99(4):373–83. <https://doi.org/10.1007/s00223-016-0153-3>.
- Zhong Q, Itokawa T, Sridhar S, et al. Effects of glucose-dependent insulinotropic peptide on osteoclast function. *Am J Physiol Endocrinol Metab.* 2007;292(2):E543–8. <https://doi.org/10.1152/ajpendo.00364.2006>.



P. Gisondi, A. C. Fostini, and G. Girolomoni

## Contents

Introduction .....	438
Specific Cutaneous Markers of Diabetes Mellitus .....	439
Acanthosis Nigricans .....	439
Necrobiosis Lipoidica Diabeticorum .....	439
Generalized Granuloma Annulare .....	441
Bullous Disease of Diabetes .....	442
Scleredema Diabeticorum .....	443
Diabetic Foot .....	443
Eruptive Xanthomas .....	444
Non-specific Skin Conditions Associated with Diabetes .....	444
Psoriasis .....	444
Acrochordons .....	445
Yellow Skin and Nails .....	446
Generalized Pruritus .....	446
Rubeosis Faciei .....	446
Diabetic Dermopathy and Pigmented Purpura .....	447
Skin Infections .....	447
Conclusions .....	448
References .....	448

## Abstract

Diabetes mellitus can cause alterations of skin homeostasis by both primary diabetes-induced changes of skin metabolism and by associated complications, such as vasculopathy and neuropathy resulting in various skin manifestations.

P. Gisondi (✉) · A. C. Fostini · G. Girolomoni  
Department of Medicine, Section of Dermatology and Venereology, University of Verona,  
Verona, Italy  
e-mail: [paolo.gisondi@univr.it](mailto:paolo.gisondi@univr.it); [annachiara.fostini@gmail.com](mailto:annachiara.fostini@gmail.com); [giampiero.girolomoni@univr.it](mailto:giampiero.girolomoni@univr.it)



Hyperglycemia-induced nonenzymatic glycation of structural and regulatory proteins plays a central role in the pathogenesis of diabetic complications. In addition, diabetic patients often exhibit altered keratinocyte functions due to the influence of insulin on keratinocyte proliferation, differentiation, and migration, resulting in impaired epidermal barrier function, delayed wound healing, and reduced stratum corneum hydration. This review describes the clinical aspects of the most common dermatologic skin manifestations that could be observed in patients with diabetes, which can be distinguished into specific cutaneous markers of diabetes and non-specific skin conditions associated with diabetes. The wide range of dermatologic conditions related to impaired glucose metabolism is important across multiple medical specialties to identify undiagnosed diabetes as early as possible and to better manage patients with known disease.

---

**Keywords**

Diabetes · Skin

---

**Introduction**

Diabetes mellitus can cause alterations of skin homeostasis by both primary diabetes-induced changes of skin metabolism and by associated complications, such as vasculopathy and neuropathy resulting in various skin manifestations. Hyperglycemia-induced nonenzymatic glycation of structural and regulatory proteins plays a central role in the pathogenesis of diabetic complications. Chemical transformation of the proteins results in the formation and accumulation of advanced glycation end products (AGEs). Specific receptors for AGEs (RAGE) are expressed by many cell types including keratinocytes (Sakaguchi et al. 2014). The accumulation of AGEs and their interaction with RAGEs initiate different intracellular signaling cascades, which are assumed to contribute to the pathogenesis of various diabetic disorders (Nowotny et al. 2015). In addition, diabetic patients often exhibit altered keratinocyte functions due to the influence of insulin on keratinocyte proliferation, differentiation, and migration, resulting in impaired epidermal barrier function, delayed wound healing, and reduced stratum corneum hydration (Wertheimer et al. 2000). Moreover, a decreased sebum secretion and altered skin elasticity have been detected in diabetic patients (Seirafi et al. 2009). It has been estimated that at least one third of patients with diabetes develop any type of skin manifestations during the course of their disease (Perez and Kohn 1994). This review describes the clinical aspects of the most common dermatologic skin manifestations that could be observed in patients with diabetes, which can be distinguished into specific cutaneous markers of diabetes and non-specific skin conditions associated with diabetes (Table 1).

**Table 1** Skin manifestations occurring in patients with diabetes

Specific	Non-specific
Acanthosis nigricans	Psoriasis
Necrobiosis lipoidica diabetorum	Acrochordons
Generalized granuloma annulare	Yellow skin and nails
Diabetic bullae	Generalized pruritus
Scleredema diabetorum	Rubeosis faciei
Diabetic foot	Pigmented purpura
Eruptive xanthomatosis	Skin infections
Adverse reaction to therapy	

## Specific Cutaneous Markers of Diabetes Mellitus

### Acanthosis Nigricans

Acanthosis nigricans (AN) is characterized by velvety hyperpigmentation and accentuation of skin markings of the intertriginous surfaces, particularly the axillae, groin, posterior neck, and, less often, extensor surfaces (Fig. 1a). AN is generally asymptomatic, but it may be painful, malodorous, or macerated in rare cases. Histologically, AN shows proliferation of epidermal keratinocytes and dermal fibroblasts and thickened stratum corneum. Probably one or more circulating factors stimulate keratinocyte proliferation, through insulin-like growth factor receptors. AN may be associated also to malignancies, in particular adenocarcinomas of the gastrointestinal tract. However, it is most frequently associated with insulin resistance and obesity (Behm et al. 2012; Murphy-Chutorian et al. 2013). In addition, AN has been reported as a rare, local, cutaneous side effect of repeated exogenous insulin injections. Rotating injection sites may help to prevent or reverse the reaction (Buzasi et al. 2011). Diagnosis of AN is usually clinical and warrants screening for diabetes and insulin resistance. New onset of AN should prompt an evaluation for underlying malignancy. AN is a chronic but reversible condition. Management focuses on treating the underlying cause. In the diabetic patient, weight control, dietary restrictions, and increased physical activity are of primary importance. Moreover, topical keratolytics (i.e., salicylic acid, retinoic acid, and ammonium lactate) and oral isotretinoin can reduce thicker plaques in areas of maceration, decreasing odor and discomfort (Murphy-Chutorian et al. 2013).

### Necrobiosis Lipoidica Diabetorum

Necrobiosis lipoidica (NL) is a chronic granulomatous skin disease that occurs primarily in individuals with diabetes, although it may be observed also in non-diabetic patients. NL occurring in diabetic patients is called necrobiosis lipoidica



**Fig. 1** Specific cutaneous markers of diabetes mellitus: acanthosis nigricans (a), bullous disease of diabetes (b), necrobiosis lipoidica (c, e), and diabetic foot (d)

diabeticorum (NLD). Typical lesions are well-demarcated, indurated, annular plaques that contain characteristic yellow brown atrophic centers studded with prominent vessels and delimited by narrow, reddish-brown, or violaceous margins (Fig. 1c, e). Solitary or multiple lesions are most commonly distributed bilaterally on the lower extremities, particularly the pretibial areas, but may occur on the face, scalp, trunk, and upper extremities. NLD can be asymptomatic or painful and/or pruritic, especially when ulcerated. Ulceration occurs in approximately one third of lesions, either spontaneously or secondary to trauma. Ulcerative lesions may be complicated by secondary infection and, more rarely, by squamous cell carcinoma. NLD occurs more frequently in type I diabetes but is associated also to type II diabetes (Shall et al. 1990). There is a female predominance with typical onset in the fourth decades of life. Distinctive necrobiosis surrounded by palisading granulomas is seen on histopathology. A retrospective review found that only 22% of 65 patients with NL had or developed diabetes over a 15-year period (O'Toole et al. 1999). Diabetes precedes the onset of NL by a mean of 10 years but can develop concurrently with or later than NL. Therefore, patients with NL with normal glucose metabolism should be closely monitored over time for diabetes or insulin resistance. The cause of NLD is unknown. Vasculopathy, collagen alterations, immune complex

deposition, and inflammatory mechanisms have all been implicated in the pathogenesis of NLD. Treatment of NL is challenging. Topical and intralesional steroids, topical calcineurin inhibitors (i.e., tacrolimus and pimecrolimus), topical tretinoin, and phototherapy are the most commonly recommended therapeutic approaches (Erfurt-Berge et al. 2012). In addition, topical granulocyte colony-stimulating factor, intralesional tumor necrosis factor (TNF)- $\alpha$  inhibitors (infliximab and etanercept), intravenous infliximab, systemic steroids, and colchicine have demonstrated efficacy in severe refractory cases of ulcerative NLD (Evans and Atherton 2002; Hu et al. 2009).

## Generalized Granuloma Annulare

Granuloma annulare is a relatively common disease that occurs in all age groups, but it is rare in infancy. Women are affected by granuloma annulare twice as often as men. Granuloma annulare is clinically characterized by many papules merging in annular plaques. The clinical variants of granuloma annulare classically described include localized, generalized, subcutaneous, and perforating type. Generalized granuloma annulare occurs predominantly in adults, and it is observed in 9–15% of all patients with granuloma annulare. Patients with generalized granuloma annulare characteristically present with a few to hundreds of 1- to 2-mm papules or nodules that range in color from flesh-toned to erythematous involving multiple body regions. Lesions may coalesce into annular plaques, which measure 3–6 cm in diameter and which may enlarge centrifugally over weeks to months. Although any part of the cutaneous surface may be involved, lesions tend to be symmetrically disposed over the trunk. Rarely, the head, palms, soles, and mucous membranes are involved. Proposed pathogenic mechanisms include primary degeneration of connective tissue leading to granulomatous inflammation, lymphocyte-mediated immune reaction with macrophage activation, and cytokine-mediated degradation of connective tissue. Granuloma annulare has been associated primarily with type I diabetes mellitus, but it is only rarely associated with type II diabetes mellitus and thyroid disease, based on an increased number of granuloma annulare patients with these diseases in small case series (Kakourou et al. 2005). Laboratory investigations are largely noncontributory in patients with granuloma annulare. With a classic history and unremarkable physical examination findings, no additional workup is necessary except for skin biopsy. Histological examination reveals foci of degenerative collagen associated with palisaded granulomatous inflammation. Macrophages surround acellular necrobiotic areas in which collagen bundles are thinned, or they sometimes have a pale, homogeneous, light-blue appearance, the latter of which is due to the presence of mucin. Treatment of the generalized disease is unfortunately fraught with a lack of consistently effective options. While the treatment of choice remains to be defined, the available literature supports the use of isotretinoin or phototherapy with oral psoralen and UV-A (PUVA) as first-line options for generalized granuloma annulare. Other anecdotal reports describe successful treatment with dapson, narrow-band UVB, systemic steroids,

pentoxifylline, hydroxychloroquine, cyclosporine, fumaric esters, interferon gamma, nicotinamide, etanercept, infliximab, adalimumab, and photodynamic therapy (Piaserico et al. 2009; Weisenseel et al. 2008; Rosmarin et al. 2009).

## **Bullous Disease of Diabetes**

Bullous disease of diabetes (bullosis diabeticorum) is a distinct, spontaneous, non-inflammatory, blistering condition of acral skin that is unique to patients with diabetes mellitus. Bullosis diabeticorum tends to arise in patients with long-standing diabetes mellitus or with multiple complications of the disease. Blisters typically heal spontaneously, within 2–6 weeks, but lesions often recur in the same or a different location. Common clinical findings of bullosis diabeticorum include tense blisters arising on non-erythematous skin. Blisters are generally quite large (from 0.5 to 17 cm in diameter), often with an irregular shape, simulating a burn (Fig. 1b). Some blisters may also be flaccid. Although blisters typically occur on the feet or lower legs, they also may occur on fingers, toes, hands, and arms. Major differential diagnosis includes bullous pemphigoid, chemical burns, epidermolysis bullosa acquisita, friction blisters, and porphyria cutanea tarda. The pathophysiology of bullous disease of diabetes is likely multifactorial. Patients with diabetes have been shown to have a lower threshold for suction-induced blister formation compared with nondiabetic controls (Bernstein et al. 1983), and because of the acral frequent localization of diabetic bullae, the role of trauma has been proposed. Electron microscopic evidence has also suggested an abnormality in anchoring fibrils. However, this alone does not explain the frequent spontaneous development of multiple lesions at several locations. In some patients, blisters are related to UV exposure, especially in those with nephropathy (Larsen et al. 2008). Poor blood glucose regulation has been associated with blister formation (Wilson et al. 2012). Approaches range from culture to skin biopsy in order to more clearly differentiate the condition from other clinically similar conditions and identify secondary infections that might require treatment. Cultures are only warranted if secondary bacterial infections are suspected. If bullous disease of diabetes blister fluid is cloudy instead of clear, the clinician should consider excluding secondary bacterial infection with culture of the blister fluid. If a patient presents with prominent involvement of the dorsal hands, evaluation of porphyrin levels is warranted. Porphyrin levels are normal in persons with bullous disease of diabetes but abnormal in case of porphyria cutanea tarda or another blistering porphyria. Individuals with end-stage renal disease may have mildly elevated plasma porphyrin levels, possibly contributing to the total pathogenesis of blister formation. Histologic features of bullous disease of diabetes are not entirely specific. Many of the reported cases describe a separation in the superficial epidermis within the superficial part of the spinous layer, but the blister plane may also appear in a subcorneal, intraepidermal, or subepidermal location. Surrounding epidermis is normal. Specific treatment of bullous disease of diabetes is unnecessary because the condition is self-limiting. The blister should be left intact whenever possible to serve as a sterile dressing and to avoid secondary infection. Antibiotics are only warranted when secondary staphylococcal infection is present.

## Scleredema Diabeticorum

Scleredema adultorum was first described by Buschke et al. in 1900 (Buschke 1900). It may be triggered by infections or be associated with systemic diseases including paraproteinemia, malignancy, as well as poorly controlled type II diabetes mellitus. This subtype of scleredema (scleredema diabeticorum) tends to occur more often in middle-aged males (at a reported 10:1 ratio), often obese, with long-standing, often uncontrolled, type II diabetes mellitus. Subtle skin hardening of the upper back begins in an insidious manner, progressing slowly over many years, to involve the upper back, neck, and shoulders. Scleredema presents as woody, non-pitting, indurated plaques. Erythema, hyperpigmentation, and/or a “peau d’ orange” appearance of the affected areas may be present. The taut skin may be firm with wrinkling of overlying epidermis. Main differential diagnosis includes amyloidosis, scleromyxedema, eosinophilic fasciitis, morphea, and nephrogenic systemic fibrosis. Imaging studies with ultrasound and/or magnetic resonance have been proposed as a method to measure induration in the involved soft tissues and monitor the response to therapy (Kurihara et al. 2011). Diabetes-associated scleredema adultorum usually shows a slow and non-resolving progress. Hyperstimulation of collagen synthesis by fibroblasts as a response to altered glucose metabolism seems to be a possible pathogenic mechanism. The histopathology of scleredema is characterized by enlarged collagen bundles separated by spaces of mucin deposits (i.e., hyaluronic acid), which results in a thickening of the dermis. The epidermis remains unaffected (Lewerenz and Ruzicka 2007). Although the disorder is usually restricted to the skin, the tongue, pharynx, esophagus, skeletal muscle, and cardiac muscle may rarely be affected. Optimal control of the glycemia does not improve scleredema (Meguerditchian et al. 2006). There is no standard therapeutic protocol, as therapeutic success is limited to case reports. Psoralen plus ultraviolet A (PUVA) or ultraviolet A1 (UVA1) phototherapy is the most beneficial approach in scleredema adultorum (Eberlein-Konig et al. 2005). Systemic corticosteroids and immunosuppressive drugs should be reserved for patients with persistent, debilitating disease in whom phototherapy has failed or for patients with scleredema-associated multiple myeloma (Rongioletti et al. 2015).

## Diabetic Foot

Diabetic foot occurs in 15–25% of diabetic patients (Singh et al. 2005) (Fig. 1d). In the development of the diabetic foot syndrome, micro- and macroangiopathy and peripheral neuropathy play crucial roles. Poor foot care, abnormal foot structure, or poorly fitting shoes are frequent trigger of diabetic ulcers. Diabetic foot ulcers can be divided into two groups: those in neuropathic feet (so-called neuropathic ulcers) and those in feet with ischemia often associated with neuropathy (so-called neuro-ischemic ulcers). The neuropathic foot is warm and well perfused with palpable pulses; sweating is diminished and the skin may be dry and prone to fissuring. The neuro-ischemic foot is a cool, pulseless foot; the skin is thin, shiny, and without hair. There is also atrophy of the subcutaneous tissue, and intermittent claudication and rest pain may be absent because

of neuropathy (Consensus Development Conference on Diabetic Foot Wound Care 1999). The ulcers usually occur in areas of increased plantar pressure such as beneath the metatarsal heads (Pavicic and Korting 2006). In addition, diabetic patients suffer from impaired wound healing; therefore, diabetic ulcers often progress, become chronic, and are risk factors for gangrene (Falanga 2005). Dry gangrene commonly manifests in a toe due to poor tissue perfusion and normally drops off naturally. In contrast, wet gangrene occurs due to infection of ulcers and requires urgent surgical intervention. Treatment of diabetic ulcers includes the elimination of plantar pressure by protective shoes, debridement, regular foot care, and moist wound treatment (Edmonds and Foster 2006). In approximately a quarter of patients with diabetic foot, an amputation will be necessary in the course of disease.

### **Eruptive Xanthomas**

Eruptive xanthomas manifest as multiple yellow papules, 1–4 mm in diameter, mainly on the extensor surfaces of the extremities and on the buttocks. The papules are surrounded by erythematous halos at their base and may be tender or pruritic (Ferrer and Miller 2002). The histopathology shows an accumulation of lipid-laden histiocytic foam cells with a mixed infiltrate of lymphocytes and neutrophils in the dermis. The prevalence of xanthomatosis among diabetic population is unclear (Parker 1985). The pathogenic mechanism for the increased frequency of eruptive xanthomatosis among individuals with diabetes has been proposed. Eruptive xanthomatosis is associated to hypertriglyceridemia. Because insulin is a stimulating factor critical to the normal activity of lipoprotein lipase, it plays an important role in the metabolism of serum triglycerides and triglyceride-rich lipoproteins. The insulin-deficient state of uncontrolled insulin-dependent diabetes results in the absence of lipoprotein lipase activity. The impaired clearance of very-low-density lipoproteins and chylomicrons leads to a hyperlipemic syndrome, which, if severe enough, can precipitate eruptive xanthomas. Diabetic hyperlipidemia may be accelerated by polyphagia caused by glycosuria. The diagnosis of eruptive xanthomatosis should prompt further investigation and treatment of hyperglycemia (Feingold and Elias 1987). Xanthomatosis resolves with control of carbohydrate and lipid metabolism; therefore the diabetic patient typically requires just optimized insulin therapy. Statins or fibrates can supplement treatment as tolerated (Wani et al. 2009).

---

## **Non-specific Skin Conditions Associated with Diabetes**

### **Psoriasis**

Chronic plaque psoriasis is a common inflammatory disease of the skin affecting 1–3% of the general population in the Western world (Parisi et al. 2013). Genetic and environmental factors play an integrated role in the pathogenesis of psoriasis. In psoriasis, the inflammatory cytokine network is deregulated, leading to the excessive release of

pro-inflammatory mediators from immune cells and increase of keratinocyte proliferation (Lowe et al. 2014). In particular, Th1 and Th17 cell populations produce different cytokines (interleukin [IL]-6, IL-17, and IL-22, interferon [IFN]- $\gamma$ , and tumor necrosis factor [TNF]- $\alpha$ ), causing abnormal differentiation and hyperproliferation of keratinocytes, blood vessel dilatation, and infiltration of leukocytes into the dermis and epidermis (Durham et al. 2015). The hallmarks of psoriasis are raised and clearly delimited erythematous lesions covered by silver scales. Psoriatic lesions are commonly localized on the elbows, knees, trunk, sacrum, and scalp; the involvement of the face, genitals, nails, and palm-plantar regions is associated with higher impact on quality of life. Psoriatic lesions are frequently symptomatic with pruritus, followed by scaling and flaking. Psoriasis may affect many facets of life including emotional, social, work, and leisure. Approximately, one third of patients present signs/symptoms of concomitant psoriatic arthritis. Patients with severe psoriasis are at increased risk of several metabolic diseases, such as obesity, diabetes, fatty liver disease, metabolic syndrome, and cardiovascular diseases. The association of psoriasis with insulin-resistance and diabetes has been investigated in several epidemiological studies and meta-analyses. The prevalence of diabetes in patients with psoriasis ranges from 4.4% to 54% (Armstrong et al. 2013). Most of the studies found that the prevalence of diabetes is higher in patients with moderate to severe psoriasis compared to mild disease (Al-Mutairi et al. 2010). In a meta-analysis of 44 studies by Coto-Segura P et al., the pooled odds ratio for the association between psoriasis and diabetes was 1.76 (95% CI 1.59–1.96). It was reported a “dose effect” in the risk of suffering from diabetes, as patients with severe psoriasis had higher risk compared with those with mild disease. The highest risk was for patients with psoriatic arthritis (OR 2.18, 95% CI 1.36–3.50) (Coto-Segura et al. 2013). In another meta-analysis of observational studies ( $n = 27$ ), psoriasis was associated also with an increased incidence of diabetes, other than prevalence. The study found that patients with psoriasis have a 27% increased risk of developing diabetes compared to the general population. In particular, those aged below 60 years and with more severe psoriasis carry the higher risk of developing diabetes (Armstrong et al. 2013). Moreover, a Danish nationwide cohort study (study period 1997–2009) including 52,613 patients with psoriasis found that the incidence rate ratios of new-onset diabetes were increased in patients with psoriasis compared with the general population (Khalid et al. 2013). On the other hand, a case-control study by Wu et al. including 41,289 subjects found that diabetic patients are at risk of developing psoriasis. The incidence rates of first-time psoriasis in diabetic patients and nondiabetic subjects were 70.2 cases and 42.5 cases per 100,000 person-years, respectively ( $p < 0.001$ ). The more severe the diabetes is, the higher the risk for psoriasis. Furthermore, thiazolidinedione use has been associated with slightly lower risk of incident psoriasis (0.87, 95% CI 0.77–0.99) (Wu et al. 2015).

## Acrochordons

Acrochordons or skin tags are benign, soft, usually flesh-colored, or hyperpigmented tumors, frequently localized on the neck, the eyelids, the axillae, and the groins (Behm et al. 2012). They can range from small papules to pedunculated polyps, typically 1 to



6 mm in diameter, with smooth or irregular surfaces. There is a slight female predilection, and prevalence increases with age (Murphy-Chutorian et al. 2013). Histologic features consist of a papillary-like dermis consisting of loose collagen fibers and thin-walled blood vessels. Multiple skin tags are associated with abnormal glucose metabolism, possibly due to insulin-induced keratinocyte proliferation. Approximately 66–75% of patients with multiple skin tags have diabetes, and more than 80% show impaired carbohydrate metabolism (Murphy-Chutorian et al. 2013). A correlation between the number of skin tags and the fasting plasma glucose value has been observed (Rasi et al. 2007). Treatment is only necessary due to cosmetic reasons. Acrochordons can be removed by excision or cryosurgery.

## **Yellow Skin and Nails**

Yellowish skin and nails are more frequently observed in diabetic patients, compared with the general population. About 40% of diabetics show yellow nails. The yellow coloration is probably caused by the effect of nonenzymatic glycosylation of dermal collagen; however the exact mechanism is not clearly understood. Onychomycosis may be considered as differential diagnosis (Murphy-Chutorian et al. 2013), and performing nail culture for the isolation of the fungi may be appropriate.

## **Generalized Pruritus**

Xerosis, drug therapy, pathogens, and the damage of sensory c-fibers in diabetic polyneuropathy may contribute to itch sensation in diabetic patients (Yamaoka et al. 2010); however generalized pruritus does not seem significantly more common in diabetic than in nondiabetic patients. Localized pruritus, especially in the genital and perianal areas, is significantly more common in diabetic women, and it is associated with poor glycemic control. In some patients, a predisposition to candidiasis may play a role. Diabetic neuropathy is characteristically associated with pain, burning, or prickling sensations, although pruritus has been described (Weisshaar et al. 2012). As pruritus often occurs in dry skin, the regular usage of emollients may partially prevent this skin complication in diabetics (Behm et al. 2012).

## **Rubeosis Faciei**

Rubeosis faciei has long been described as a common manifestation of diabetes mellitus. The condition is characterized by a chronically flushed appearance of the face, neck, and upper extremities (Fig. 2d). It may result from microangiopathic alterations and superficial facial venous dilatation. Although rubeosis is a benign condition, it may serve as a clue to microangiopathy secondary to suboptimal glycemic control. Therefore, patient evaluation for serious complications such as retinopathy is recommended. Treatment of rubeosis faciei is strict diabetic control and avoidance of alcohol, caffeine, and other vasodilators (Murphy-Chutorian et al. 2013).



**Fig. 2** Non-specific skin conditions associated with diabetes mellitus: tinea pedis (a), onychomycosis of the first and second toes (b), candidal intertrigo of mammary fold (c), rubeosis faciei (d), and pigmented purpura of a leg (e)

## Diabetic Dermopathy and Pigmented Purpura

Diabetic dermopathy affects 10% of diabetic patients. It is a sign of microangiopathy, characterized by multiple asymptomatic, round, dull red to pink papules or plaques predominantly on the pretibial skin evolving in atrophic macules with fine scale. Sometimes they may be complicated by ulceration. An association with coronary artery disease, neuropathy, nephropathy, and retinopathy has been identified. Thus, diabetic dermopathy may be considered a clinical marker for the severity of systemic diabetic complications (Behm et al. 2012). Pigmented purpura coexists with diabetic dermopathy in about 50% of cases. In the absence of diabetic dermopathy, pigmented purpura is not considered a marker for diabetes. It is a wide group of uncommon, idiopathic, progressive skin conditions, being Schamberg's disease the most common form. Pigmented purpura is characterized by asymptomatic, non-blanching, orange to brown patches, distributed mainly over the lower extremities, especially the pretibial leg (Fig. 2e). It is caused by erythrocyte extravasation from the superficial venous plexus (Murphy-Chutorian et al. 2013). No medical intervention is necessary, but ascorbic acid and rutoside may be helpful.

## Skin Infections

The impaired microcirculation, sensory and autonomic neuropathy, acid-base imbalances, and impaired immune response of diabetes mellitus and its complications predispose diabetic patients to bacterial and fungal infections of the skin more frequently

compared with general population. Recurrent skin infections such as impetigo contagiosa, abscesses, erythrasma, folliculitis, erysipelas, or severe fungal infections may be the presenting feature of diabetes. The most common bacterial infections in diabetic patients are staphylococcal and beta-hemolytic streptococcal infections. Skin swab for culture is recommended for the microbe identification. Depending on the severity of the infection, oral or intravenous antibiotics and diabetic control are mandatory. *Pseudomonas* infections of the toe web spaces and colonization of the toenails required topical and systemic antibiotics such as oral ciprofloxacin. Malignant otitis externa caused by *Pseudomonas aeruginosa* is a rare life-threatening skin infection of the external auditory canal, associated with high morbidity and mortality. Antibiotic therapy and necrotic tissue debridement should be initiated promptly. *Candida* infections are often seen in the setting of diabetes. They include angular stomatitis, paronychia, thrush, and intertrigo of the skin folds (Fig. 2c). Common female-specific *Candida* skin infections include pruritus vulvae (often accompanying vulvovaginitis) and inframammary fold infection. *Candida* infections should be managed with topical antifungals and/or oral fluconazole for more severe or refractory cases as well as glycemic control. Dermatophyte infections of the skin are most frequently caused by *Trichophyton rubrum*. Tinea pedis is the most prevalent dermatophytosis among diabetic patients (Fig. 2a). Skin scrapings for direct fungi microscopy and culture are indicated. Treatment of dermatophytosis includes topical and systemic antifungals and the management of potential superimposed bacterial infections. Onychomycosis (fungal infection of the nail) is common in diabetes, most often caused by *Candida* or *Trichophyton*. Signs of onychomycosis include yellow discoloration, subungual hyperkeratosis, distal onycholysis, and nail dystrophy (Fig. 2b). Nail culture for the isolation of the fungi is indicated. Nail infections can provide a portal of entry for secondary bacterial infection including erysipelas. Patients should be educated about the importance of proper foot and nail care for prevention of infections (Behm et al. 2012; Murphy-Chutorian et al. 2013).

---

## Conclusions

The wide range of dermatologic conditions related to impaired glucose metabolism is important across multiple medical specialties to identify undiagnosed diabetes as early as possible and to better manage patients with known disease. Despite numerous investigations, the exact causes of many cutaneous complications of diabetes remain elusive.

---

## References

- Al-Mutairi N, Al-Farag S, Al-Mutairi A, Al-Shiltawy M. Comorbidities associated with psoriasis: an experience from the Middle East. *J Dermatol*. 2010;37:146–55.
- Armstrong AW, Harskamp CT, Armstrong EJ. Psoriasis and the risk of diabetes mellitus: a systematic review and meta-analysis. *JAMA Dermatol*. 2013;149:84–91.

- Behm B, Schreml S, Landthaler M, Babilas P. Skin signs in diabetes mellitus. *J Eur Acad Dermatol Venereol.* 2012;26:1203–11.
- Bernstein JE, Levine LE, Medenica MM, Yung CW, Soltani K. Reduced threshold to suction-induced blister formation in insulin-dependent diabetics. *J Am Acad Dermatol.* 1983;8:790–1.
- Buschke A. Vorstellung eines Falles von Sklero“dem vor der Berliner Gesellschaft für Dermatologie. *Arch Dermatol Syph.* 1900;52:383.
- Buzasi K, Sapi Z, Jermendy G. Acanthosis nigricans as a local cutaneous side effect of repeated human insulin injections. *Diabetes Res Clin Pract.* 2011;94:e34–6.
- Consensus Development Conference on Diabetic Foot Wound Care: 7–8 Apr 1999, Boston, MA. American Diabetes Association. *Diabetes Care* 1999;22:1354–60.
- Coto-Segura P, Eiris-Salvado N, González-Lara L, Queiro-Silva R, Martínez-Cambolor P, Maldonado-Seral C, García-García B, Palacios-García L, Gomez-Bernal S, Santos-Juanes J, Coto E. Psoriasis, psoriatic arthritis and type 2 diabetes mellitus: a systematic review and meta-analysis. *Br J Dermatol.* 2013;169:783–93.
- Durham LE, Kirkham BW, Taams LS. Contribution of the IL-17 pathway to psoriasis and psoriatic arthritis. *Curr Rheumatol Rep.* 2015;17:55.
- Eberlein-Konig B, Vogel M, Katzer K, Hein R, Köhn FM, Ring J, Abeck D. Successful UVA1 phototherapy in a patient with scleredema adultorum. *J Eur Acad Dermatol Venereol.* 2005;19:203–4.
- Edmonds ME, Foster AV. Diabetic foot ulcers. *BMJ.* 2006;332:407–10.
- Erfurt-Berge C, Seitz AT, Rehse C, Wollina U, Schwede K, Renner R. Update on clinical and laboratory features in necrobiosis lipoidica: a retrospective multicentre study of 52 patients. *Eur J Dermatol.* 2012;22:770–5.
- Evans AV, Atherton DJ. Recalcitrant ulcers in necrobiosis lipoidica diabetorum healed by topical granulocyte-macrophage colony-stimulating factor. *Br J Dermatol.* 2002;147(5):1023.
- Falanga V. Wound healing and its impairment in the diabetic foot. *Lancet.* 2005;366:1736–43.
- Feingold KR, Elias PM. Endocrine-skin interactions. Cutaneous manifestations of pituitary disease, thyroid disease, calcium disorders, and diabetes. *J Am Acad Dermatol.* 1987;17:921–40.
- Ferringer T, Miller F 3rd. Cutaneous manifestations of diabetes mellitus. *Dermatol Clin.* 2002;20:483–92.
- Hu SW, Bevona C, Winterfield L, Qureshi AA, Li VW. Treatment of refractory ulcerative necrobiosis lipoidica diabetorum with infliximab: report of a case. *Arch Dermatol.* 2009;145:437–9.
- Kakourou T, Psychou F, Voutetakis A, Xaidara A, Stefanaki K, Dacou-Voutetakis C. Low serum insulin values in children with multiple lesions of granuloma annulare: a prospective study. *J Eur Acad Dermatol Venereol.* 2005;19:30–4.
- Khalid U, Hansen PR, Gislason GH, Lindhardsen J, Kristensen SL, Winther SA, Skov L, Torp-Pedersen C, Ahlehoff O. Psoriasis and new-onset diabetes. *Diabetes Care.* 2013;36:2402–7.
- Kurihara Y, Kokuba H, Furue M. Case of diabetic scleredema: diagnostic value of magnetic resonance imaging. *J Dermatol.* 2011;3:693–6.
- Larsen K, Jensen T, Karlsmark T, Holstein PE. Incidence of bullosis diabetorum – a controversial cause of chronic foot ulceration. *Int Wound J.* 2008;5:591–6.
- Lewerenz V, Ruzicka T. Scleredema adultorum associated with type 2 diabetes mellitus: a report of three cases. *J Eur Acad Dermatol Venereol.* 2007;21:560–1.
- Lowes MA, Suarez-Farinas M, Krueger JG. Immunology of psoriasis. *Annu Rev Immunol.* 2014;32:227–55.
- Meguerditchian C, Jacquet P, Béliard S, Benderitter T, Valéro R, Carsuzza F, Vialettes B. Scleredema adultorum of Buschke: an under recognized skin complication of diabetes. *Diabetes Metab.* 2006;32:481–4.
- Murphy-Chutorian B, Han G, Cohen SR. Dermatologic manifestations of diabetes mellitus a review. *Endocrinol Metab Clin North Am.* 2013;42:869–98.
- Nowotny K, Jung T, Höhn A, Weber D, Grune T. Advanced glycation end products and oxidative stress in type 2 diabetes mellitus. *Biomolecules.* 2015;5:194–222.

- O'Toole EA, Kennedy U, Nolan JJ, Young MM, Rogers S, Barnes L. Necrobiosis lipoidica: only a minority of patients have diabetes mellitus. *Br J Dermatol.* 1999;140:283–6.
- Parisi R, Symmons DP, Griffiths CE, Ashcroft DM. Global epidemiology of psoriasis: a systematic review of incidence and prevalence. *J Invest Dermatol.* 2013;133:377–85.
- Parker F. Xanthomas and hyperlipidemias. *J Am Acad Dermatol.* 1985;13:1–30.
- Pavicic T, Korting HC. Xerosis and callus formation as a key to the diabetic foot syndrome: dermatologic view of the problem and its management. *J Dtsch Dermatol Ges.* 2006;4:935–41.
- Perez MI, Kohn SR. Cutaneous manifestations of diabetes mellitus. *J Am Acad Dermatol.* 1994;30:519–31.
- Piaserico S, Zattra E, Linder D, Peserico A. Generalized granuloma annulare treated with methyaminolevulinate photodynamic therapy. *Dermatology.* 2009;218:282–4.
- Rasi A, Soltani-Arabshahi R, Shahbazi N. Skin tag as a cutaneous marker for impaired carbohydrate metabolism: a case-control study. *Int J Dermatol.* 2007;46:1155–9.
- Rongioletti F, Kaiser F, Cinotti E, Metzke D, Battistella M, Calzavara-Pinton PG, Damevska K, Girolomoni G, André J, Perrot JL, Kempf W, Cavelier-Balloy B. Scleredema. A multicentre study of characteristics, comorbidities, course and therapy in 44 patients. *J Eur Acad Dermatol Venereol.* 2015;29:2399–404.
- Rosmarin D, LaRaia A, Schlauder S, Gottlieb AB. Successful treatment of disseminated granuloma annulare with adalimumab. *J Drugs Dermatol.* 2009;8:169–71.
- Sakaguchi M, Murata H, Aoyama Y, Hibino T, Putranto EW, Ruma IM, Inoue Y, Sakaguchi Y, Yamamoto K, Kinoshita R, Futami J, Kataoka K, Iwatsuki K, Huh NH. DNAX-activating protein 10 (DAP10) membrane adaptor associates with receptor for advanced glycation end products (RAGE) and modulates the RAGE-triggered signaling pathway in human keratinocytes. *J Biol Chem.* 2014;289:23389–402.
- Seirafi H, Farsinejad K, Firooz A, Davoudi SM, Robati RM, Hoseini MS, Ehsani AH, Sadr B. Biophysical characteristics of skin in diabetes: a controlled study. *J Eur Acad Dermatol Venereol.* 2009;23:146–9.
- Shall L, Millard L, Stevens A. Necrobiosis lipoidica: 'the footprint not the footstep'. *Br J Dermatol.* 1990;123:47.
- Singh N, Armstrong DG, Lipsky BA. Preventing foot ulcers in patients with diabetes. *JAMA.* 2005;293:217–28.
- Wani AM, Hussain WM, Fatani MI, Qadmani A, Akhtar M, Maimani GA, Turkistani A, Bafaraj MG, Dairi KS. Eruptive xanthomas with Koebner phenomenon, type 1 diabetes mellitus, hypertriglyceridaemia and hypertension in a 41-year-old man. *BMJ Case Rep* 2009;2009. pii: bcr05.2009.1871.
- Weisenseel P, Kuznetsov AV, Molin S, Ruzicka T, Berking C, Prinz JC. Photodynamic therapy for granuloma annulare: more than a shot in the dark. *Dermatology.* 2008;217:329–32.
- Weisshaar E, Fleischer A, Bernhard J, Cropley T. Pruritus and dysesthesia. In: Bologna JL, Jorizzo JL, Schaffer J, editors. *Dermatology.* New York: Elsevier Limited; 2012. p. 111–25.
- Wertheimer E, Trebicz M, Eldar T, Gartsbein M, Nofeh-Moses S, Tennenbaum T. Differential roles of insulin receptor and insulin-like growth factor-1 receptor in differentiation of murine skin keratinocytes. *J Invest Dermatol.* 2000;115:24–9.
- Wilson TC, Snyder RJ, Southerland CC. Bullous diabeticorum: is there a correlation between hyperglycemia and this symptomatology? *Wounds.* 2012;24:350–5.
- Wu CY, Shieh JJ, Shen JL, Liu YY, Chang YT, Chen YJ. Association between antidiabetic drugs and psoriasis risk in diabetic patients: results from a nationwide nested case-control study in Taiwan. *J Am Acad Dermatol.* 2015;72:123–30.
- Yamaoka H, Sasaki H, Yamasaki H, Ogawa K, Ohta T, Furuta H, Nishi M, Nanjo K. Truncal pruritus of unknown origin may be a symptom of diabetic polyneuropathy. *Diabetes Care.* 2010;33:150–5.



Thomas W. Oates and Namita Khandelwal

## Contents

Introduction .....	452
The Effects of Diabetes on Periodontal Disease .....	453
Pathogenesis of Periodontal Disease .....	453
Periodontal Disease as a Complication of Diabetes .....	455
The Bidirectional Relationship Between Diabetes and Oral Health .....	457
The Role of Periodontal Disease on Glycemic Status for Patients with Type 2 Diabetes .....	458
Diabetes and Dental Implant Therapy .....	461
Summary .....	467
References .....	468

## Abstract

Periodontal disease represents an inflammation-driven insult to the supporting tissues of the dentition. It is a chronic, complex disease developing from an altered inflammatory response in association with a pathogenically evolving polymicrobial infection. This complex inflammatory state has a direct impact on the supporting tissues of the dentition along with the potential for systemic sequelae with diabetes. This review explores the current understanding of the impact of diabetes on periodontal disease and dental implant therapy as well as the potential impact of periodontal disease on diabetes.

---

T. W. Oates (✉)

Department of Advanced Oral Sciences and Therapeutics, University of Maryland, Baltimore, MD, USA

e-mail: [toates@umaryland.edu](mailto:toates@umaryland.edu)

N. Khandelwal

College of Dental Medicine, University of New England, Portland, ME, USA

e-mail: [nkhandelwal@une.edu](mailto:nkhandelwal@une.edu)

**Keywords**

Periodontal · Diabetes mellitus · Dental implant · Inflammation · Pathogenesis

**Introduction**

Periodontal disease represents an inflammation-driven insult to the supporting tissues of the dentition. It is a chronic, complex disease developing from an altered inflammatory response in association with a pathogenically evolving polymicrobial infection. The periodontal tissues include the superficial mucosal tissues along with the underlying osseous tissue and the ligamentous attachment of the cemental layer of the root surface to the soft tissue and bone. Periodontal disease may affect only the superficial mucosal tissues or may extend to involve the tooth supporting bone and ligament tissues as well.

In its mildest forms, periodontal disease is limited to a localized soft tissue inflammation that is readily reversible following disruption of the maturation of the microbial biofilm or plaque. However, more destructive forms of periodontal disease lead to the degradation of both the soft and hard tissue support of the dentition. In most severe forms, it may ultimately result in the loss of teeth.

Destructive periodontal disease has been estimated to affect over 50% of adults worldwide, with its most severe forms affecting as much as 15% of the adult population (Demmer and Papapanou 2010). For these most severely involved patients, the associated loss of teeth may lead to masticatory dysfunction with nutritional implications (Fig. 1). This potential for nutritional compromise is of greatest concern for patients with diabetes mellitus who are critically dependent on dietary management of their diabetes. In this sense, periodontal disease may contribute to compromises in the patient's overall management of their diabetic condition. However, additional interactions between these two conditions have been considered.

**Fig. 1** Intraoral clinical photograph of a patient with advanced periodontal disease and poorly controlled type 2 diabetes mellitus. Tooth loss in the maxillary anterior may alter chewing function as well as affect self-esteem. Mandibular anterior teeth show signs of severe destruction of the supporting tissues and heavy deposits of etiologic factors, plaque, and calculus



While diabetes, with its microvascular comorbidities, is thought to contribute to the development or worsening of periodontal disease, there is also evidence suggesting that periodontal disease may contribute to a worsening of glycemic control for patients with diabetes. It is in this light that periodontal disease is considered as having a bidirectional relationship with diabetes mellitus.

Central to this bidirectional relationship between periodontal disease and diabetes is the role of inflammation (Lalla and Papapanou 2011). Diabetes leads to compromises in the patient's immune response to infection. It follows that these effects may be evident in the immune response to the polymicrobial periodontal infection, that is, periodontal disease. It would be expected that patients with diabetes may be more susceptible to periodontal disease and that it may present with greater severity. In fact, periodontal disease has been considered as a "sixth" complication of diabetes.

It is also thought that inflammatory- and infection-related molecules associated with periodontal disease directly contribute to systemic manifestations. As understanding of the role of inflammation in insulin resistance evolves, there is evidence that suggests inflammatory periodontal disease may contribute to a systemic inflammatory burden worsening the diabetic condition. As this question has availed itself to interventional studies, this chapter will explore the latest information relating periodontal disease and the effects of its treatment on glycemic status for patients with diabetes.

Oral health is critical to proper masticatory function and nutrition, especially so for patients with diabetes. One of the most promising therapeutic options for patients suffering from tooth loss is dental implant therapy. However, current practices have limited dental implant therapy to include only diabetes patients with good glycemic control, thus excluding this therapeutic option for patients most compromised in their overall management of their diabetic condition. Given the potential for poor diabetic management to contribute to periodontal disease and tooth loss, it may be these individuals who may have the most to gain from tooth replacement through dental implant therapy. This chapter will also explore the current understanding of the use of dental implant therapy for patients with diabetes and its implications on bone metabolism.

Overall, the goals of this review are (1) to clarify the strengths and limitations in understanding of the bidirectional relationship between diabetes mellitus and periodontal disease and (2) to better understand the potential for diabetes patients suffering from tooth loss to restore oral function using dental implant therapy.

---

## **The Effects of Diabetes on Periodontal Disease**

### **Pathogenesis of Periodontal Disease**

Periodontal disease represents a commonly occurring, complex, chronic disease of the supporting tissues of the dentition. The pathogenesis of this condition is dependent on the development and maturation of a microbial biofilm leading to a chronic inflammation along the soft tissue-tooth interface. Early in the development of the



microbial biofilm, there is a universal inflammatory response in the adjacent soft tissue, gingivitis. This inflammatory response to bacterial components, e.g., lipopolysaccharides (LPS), develops through toll-like receptors (TLR-2) initiating an innate immune response. The inflammatory response results in the release of inflammatory cytokines, including IL-1 $\beta$  and TNF- $\alpha$ . At this stage, the inflammatory response is readily reversible with disruption of the biofilm and inflammatory components and no permanent alteration to the supporting tissues of the teeth.

In many individuals, this limited inflammatory response persists indefinitely. In other individuals, there is an evolution of the microbial profile in association with an extension of the inflammatory front deeper into the tissues, resulting in the irreversible degradation of the supporting alveolar bone and periodontal ligament tissues supporting the teeth. The exact mechanisms triggering the progression of this reversible inflammatory condition toward an irreversible, destructive periodontitis are not clear. However, it is likely that there are numerous alterations in both innate and adaptive immune pathways that result in the degradation of connective tissues extending to the supporting alveolar bone. While studies have documented plausible contributions to many of the components of the immune response, more recent studies have begun to define the integrated effects of the host and the coevolution of microbial pathogens leading to the localized disruption of a physiologic immune response.

The microbial biofilm in general does lead to an inflammatory response in the soft tissues surrounding the tooth, but it is not sufficient to induce degradation of the soft and hard connective tissues. It appears that a pathogenic pattern of maturation of the polymicrobial biofilm within the tissue space adjacent to the tooth, i.e., the sulcus, is critical to this pathogenic transformation (Fig. 2a). Recent evidence has supported a keystone pathogen model in which specific pathogenic bacterial components inactivate the complement cascade while extending an inflammatory response toward the alveolar bone and foster a unique environment that supports further maturation of the biofilm toward a pathogenic state. In addition, these pathogens also impair the ability of leukocytes to kill the microflora allowing the maturation process to extend toward tissue destruction (Fig. 2b; Lamont and Hajishengallis 2015; Hajishengallis 2014; Jiao et al. 2014). This ecologically derived model suggests the importance of environmental alterations through complex host-microbial interactions in a pathogenic direction as critical to triggering the degradation of the alveolar bone and connective tissues supporting the teeth, i.e., periodontitis.

Given the complexity of these host-microbial interactions, it would not be surprising that hyperglycemia and diabetes may provide additional factors influencing this pathogenic process, with the potential to further tissue destruction. While there is limited evidence that diabetes may alter this complex interplay, there has been little consideration of keystone pathogens, the potential for diversity in both keystone and secondary pathogens, or unique contributions to the microenvironment with diabetes. Multiple alterations in host response have been identified with diabetes that may contribute to increased severity of periodontal disease, including

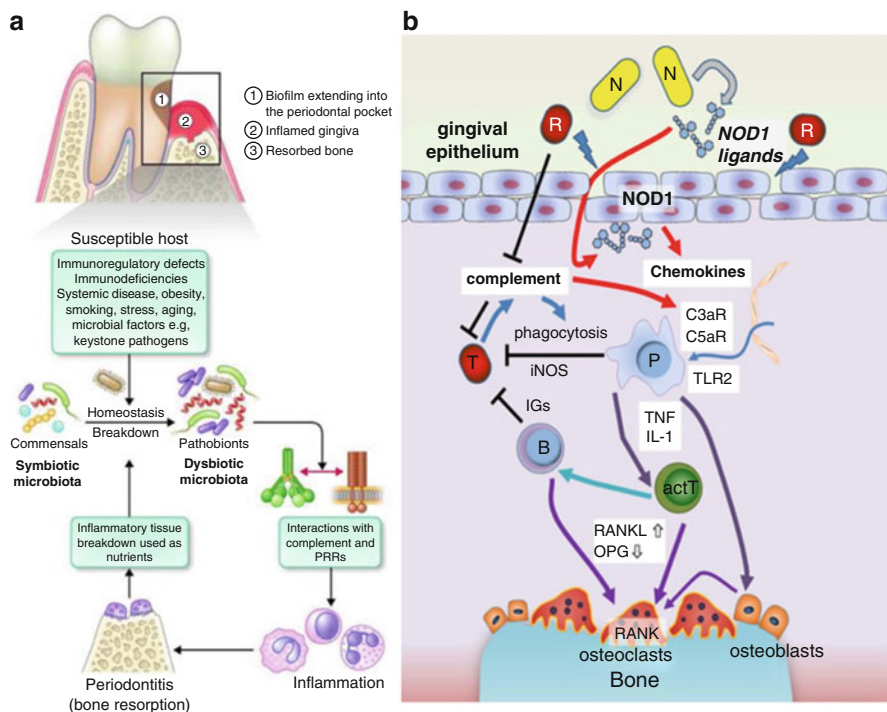

**Fig. 2** Proposed keystone pathogen models leading to the development of periodontitis. Pathogenic transformation of dental biofilm can lead to the disruption of the epithelial tissues, inactivation of the complement system, activation of a Th17 response, and production of NOD1 ligands extending the host inflammatory front toward the alveolar bone. This complex interplay of microbes and host leads to destruction of the supporting tissues of the tooth. ((a) From Fig. 1 Hajishengallis 2014; (b) from Fig. 3 from Jiao et al. 2014, JDR)

decreases in neutrophil activity, macrophage hyperactivity, AGE alterations, and decreased bone formation. Recognizing the potential interplay between diabetes, host alterations, and microbial biofilm maturation, it is not surprising that the development of periodontal disease would be a concern for patients with diabetes.

### Periodontal Disease as a Complication of Diabetes

Diabetes mellitus is often considered a strong risk factor for the development or worsening of periodontal disease; however, based on the limited studies available, this relationship is not clear for type 1 diabetes (Khader et al. 2006). A recent systematic review (Chávarry et al. 2009) failed to identify a significant relationship between type 1 diabetes and destructive periodontal disease. However, one case-control study suggested that children with type 1 diabetes are affected by periodontal disease at an earlier age and with a greater severity and identified an almost fourfold

increased risk for loss of periodontal tissues with diabetes. These children were shown to have worsening of both tissue inflammation and loss of supporting tissues. Of note, these destructive forms of periodontal disease were evident in children under 12 years of age, and worsened periodontal conditions were directly associated with HbA1c but not with diabetes duration (Lalla et al. 2006, 2007). Another study looking at adults with type 1 diabetes found that the relationship with periodontal disease is not quite as clear. This study included 179, type 1 diabetes adult patients and failed to find an association between type 1 diabetes and periodontal disease. These patients had a mean age of 38, a mean HbA1c of 8.3%, and a duration of 16.4 years (Pranckeviciene et al. 2014).

A recent cross-sectional study (Kaur et al. 2009) separately evaluated type 1 ( $n = 145$ ) and type 2 ( $n = 182$ ) adult diabetes patients relative to age-matched, nondiabetic patients for both periodontal disease and tooth loss. HbA1c levels greater than 7% were found in 63% of the type 1 subjects and in 48% of the type 2 subjects. Analysis showed that subjects with type 1 diabetes had a significant association between periodontal attachment loss across age groups and with tooth loss in the older age groups. These findings suggest that periodontal destruction is more prevalent in the younger cohorts but does not result in increased tooth loss until an older age. For subjects with type 2 diabetes, there was a similar relationship between diabetes and increased periodontal attachment loss; however, there was no clear association with tooth loss for patients with type 2 diabetes. Together, these findings do support concerns for compromised oral health but also demonstrate the confounded nature of these relationships as currently understood.

The strongest evidence to date regarding the effects of diabetes on periodontal health comes from a series of studies of the Pima Indians in Arizona. This population has an extremely high prevalence of type 2 diabetes and has been evaluated in cross-sectional and longitudinal studies (Emrich et al. 1991; Nelson et al. 1990). Cross-sectional evaluation showed an association between diabetes and periodontal tissue destruction with odds ratios of 2.8 or greater. Interestingly, the oldest age group (55+) failed to identify a similar association for periodontal attachment loss, which may be confounded by tooth loss.

An associated evaluation of prediabetes and newly diagnosed diabetes patients from the above study failed to identify significant associations with periodontal disease or tooth loss (Kowall et al. 2015). However, looking at patients with HbA1c  $>7\%$ , subtle associations were found. These findings suggest that any associations are likely related to either hyperglycemia or diabetes duration.

A second study relied on a self-reported survey of diabetes status and tooth loss (Kapp et al. 2007) to evaluate this relationship. This telephone survey contacted over 155,000 adults, 4.6% of whom reported having diabetes and 62% reported no tooth loss. This study identified a modest 1.1 odds ratio for those reporting diabetes to have had at least one tooth removed and a 1.5 odds ratio to have had more than five teeth removed. In contrast to the previous study, increased age of respondent was not associated with an increased risk of tooth loss for patients reporting diabetes. Consistent with these limited findings, another self-report study in New Zealand

failed to show support for this association with odds ratios ranging from 0.7 to 1.5 (Knight et al. 2015). This study had 3.6% of the approximately 2000 subjects report as having diabetes.

Taken together, these studies offer a mixed perspective; however, there is evidence that periodontal disease may be a “sixth” complication of diabetes mellitus. If so, the relationship appears more evident in type 2 diabetes in combination with other common factors associated with periodontal disease, including increased age and smoking (Costa et al. 2013). And consistent with other comorbidities of diabetes, it appears that poorer glycemic control may contribute to the worsening of periodontal disease for patients with diabetes mellitus (Botero et al. 2012; Costa et al. 2013).

---

## The Bidirectional Relationship Between Diabetes and Oral Health

As discussed above, periodontal disease may be considered a complication of diabetes with this association relative to glycemic control. Most recent efforts have focused on the role of periodontal inflammation as a contributor to insulin resistance and elevated glycemic levels. This second concept suggests a bidirectional relationship between these two chronic conditions (Preshaw et al. 2012). It also suggests that the interplay between these two conditions may create a cyclic phenomenon in which each condition may exacerbate the other; that is, worsening periodontal disease as a consequence of diabetes may lead to an increased hyperglycemia, which in turn may worsen periodontal disease. While the concept of a bidirectional relationship between oral health and diabetes has received considerable attention, much remains in question as to the strength of these associations and the potential for causation as suggested above.

These questions include an appreciation of the amount and severity of periodontal disease for patients with diabetes, the relative differences between type 1 and type 2 diabetes, and effects relative to tooth loss and compromised function (Khader et al. 2006). Furthermore, there remain numerous methodologic limitations to many of the interventional studies exploring the role of periodontal disease in hyperglycemia (Simpson et al. 2015). Periodontitis appears to be both patient specific and, for affected patients, site specific, with severely affected teeth often adjacent to those relatively unaffected. As a consequence, it does become difficult to appropriately classify the levels of periodontal disease in studies evaluating its relationship with systemic conditions such as diabetes.

Typically to classify periodontal disease, measurements of the linear destruction (in millimeters) over a specified number of teeth or average over all teeth present are used to determine the presence, extent, and severity of periodontal disease. As this condition may lead to tooth loss, the number of missing teeth may serve as an indirect measure of periodontal disease. Unfortunately, each of these approaches has its limitations in association with systemic effects, collectively contributing to some of the ambiguities found in the literature regarding periodontal disease and diabetes.

## The Role of Periodontal Disease on Glycemic Status for Patients with Type 2 Diabetes

A role for periodontal disease affecting systemic conditions has become of increasing interest since the 1990s. This renewed interest developed in conjunction with the development of the “common soil” hypothesis. This hypothesis proposed a direct relationship with systemic inflammation as an underlying cause for the relationship between the metabolic syndrome and cardiovascular disease (Stern 1995). This common soil hypothesis was subsequently extended to periodontal disease with early reports suggesting relationships for periodontal disease with both cardiovascular disease and adverse pregnancy outcomes (Beck et al. 1996; Offenbacher et al. 1996). Diabetes, in particular hyperglycemia through increased insulin resistance, was soon also considered in part as a systemic manifestation of this oral inflammatory condition (Mealey and Rethman 2003).

The association between periodontal disease and hyperglycemia has been the subject of multiple observational and interventional trials assessing the potential for periodontal therapeutic interventions to reduce hyperglycemia as measured using changes in glycated hemoglobin A1c (HbA1c). The findings of many of the earlier reports have been documented in a number of systematic reviews supporting periodontal intervention leading to reductions in HbA1c levels ranging from 0.27% to 0.65% over 3–6 months following periodontal therapy, with a mean improvement of 0.46% (Faggion et al. 2016).

These findings certainly are consistent with the “common soil” hypothesis suggesting that eliminating this local, oral inflammatory condition contributes at a systemic level to decreased insulin resistance and offered some promise for the reduction in periodontal disease as part of the overall management for patients with diabetes. However, most of the studies under consideration were small in size and often limited in strength of design, and systematic, or umbrella, reviews of initial systematic reviews are beginning to document the potential for methodologic limitations to contribute to these positive associations (Botero et al. 2016; Faggion et al. 2016).

This is further supported by multiple systematic reviews that have documented design and reported limitations in most of the randomized, controlled trials exploring this question. Several reviews have evaluated their outcomes with consideration for risk of methodologic bias (Fig. 3; Li et al. 2015; Corbella et al. 2013). Interestingly, each of these studies has identified significant periodontal treatment effects in studies deemed at higher risk of bias but has failed to identify treatment effects in studies with lower risk of bias. Together, these systematic reviews support potential bias as a likely explanation for the varied results found in the randomized, controlled trials evaluating periodontal interventions on glycemic control. Consistent with this assessment, a recent and largest ( $n = 257$ ), well-designed, randomized clinical trial addressing the potential for periodontal therapy to improve glycemic status failed to identify any benefits from periodontal therapy on HbA1c levels over 3 and 6 months following treatment (Engebretson et al. 2013).

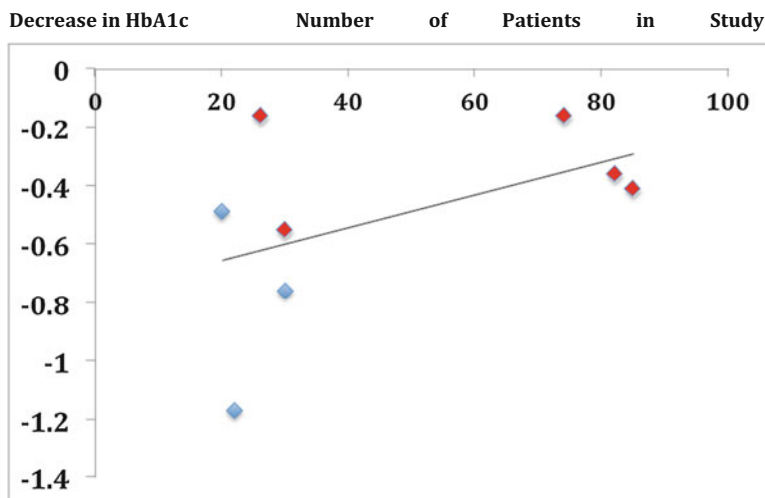

**Fig. 3** Systematic review evaluation of study treatment effects on HbA1c relative to sample size and risk of bias (data based on Corbella et al. 2013). Treatment effects, with *negative numbers indicating decreased HbA1c following treatment*, are shown relative to study size and determined risk of bias (high risk of bias in blue, low risk of bias in red)

As these studies look to identify systemic consequences of periodontal infection, it is fair to consider other systemic conditions that may be similarly affected. The systemic condition most studied to date evaluating the effects of periodontal disease has been adverse pregnancy outcomes. The pregnancy outcomes considered may vary between studies but mostly have focused on preterm delivery and low birth weight. A systematic review evaluating adverse pregnancy outcomes nicely demonstrates the same limitations with studies addressing the effects of periodontal therapy on pregnancy outcomes, that is, smaller, less robust, and potentially more biased studies seem to show an association between periodontal disease and the systemic outcome, whereas larger, better designed studies fail to identify any benefits from periodontal therapy (Fig. 4; Polyzos et al. 2010).

It is clear in review of the literature that each of these conditions, diabetes and adverse pregnancy outcomes, has been investigated heavily through a number of randomized clinical trials. Investigation of these relationships also includes numerous systematic reviews looking to more broadly coalesce these findings for each condition into a clear and relevant conclusion. Most recently, López et al. (2015) evaluated the effects of periodontal therapy on pregnancy outcomes through a systematic review emphasizing the importance of bias assessment. Three meta-analyses that considered risk of bias were identified, with all three failing to see a treatment effect in studies with a low risk of bias. Interestingly, each of these systematic reviews ended up with different RCTs included based on unique criteria. This further supports the potential role for bias in explaining disparate outcomes found in the literature.

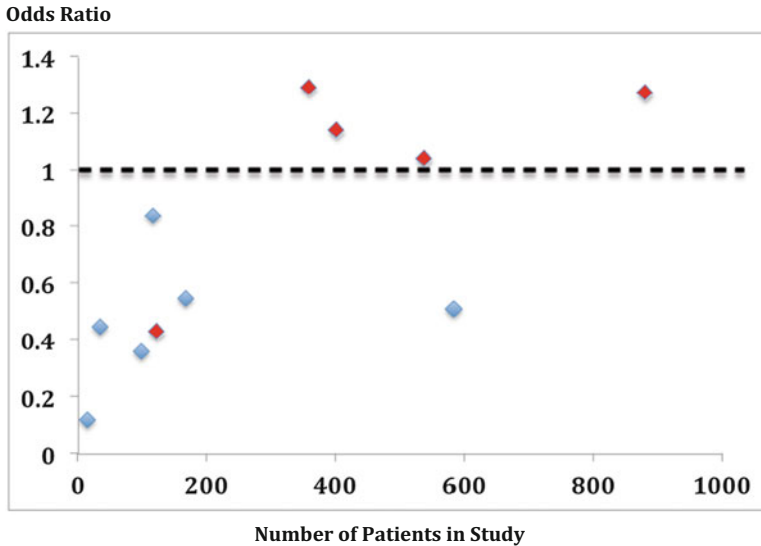
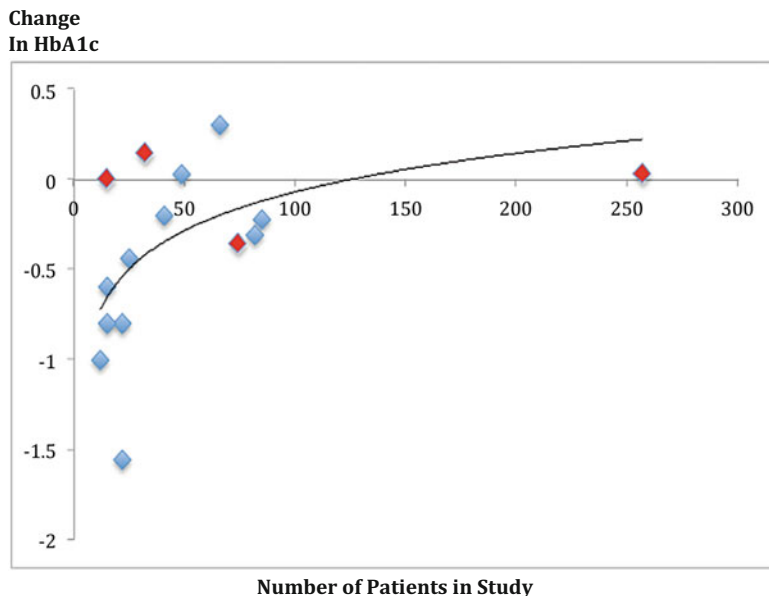

**Fig. 4** Studies evaluating effects of periodontal therapy on adverse pregnancy outcomes (data based on Polyzos et al. 2010, Fig. 6). Treatment effects are shown relative to study size (*positive effects less than 1*) and determined risk of bias (high risk of bias in blue, low risk of bias in red)

Lopez (2015) also discusses the importance of considering confounding factors in preterm birth as exclusion criteria. While critical in minimizing bias by proper inclusion of participants, it is equally critical to consider medical confounders that may develop during the intervention and assessment phases of the trials. In many of these studies, medical confounders are overlooked.

The occurrence of medical complications and/or management during an ongoing trial presents a major confounding factor. Given the complex nature of these conditions, the medical management of the systemic condition represents a critical component of quality assessment for these interventional studies that has yet to be considered in a systematic manner. On closer inspection for any consideration for medical management changes for diabetes during the RCTs evaluating the effects of periodontal treatment on HbA1c, it appears that only four studies have given this any consideration within their methodology (Fig. 5). These findings suggest that discrepancies of HbA1c effects with periodontal treatment may be explained in part by the confounding of medical management during periodontal intervention studies underpowered to allow randomization to effectively mitigate this component.

In summary, the potential for the detrimental interplay between periodontal disease and diabetes mellitus certainly remains. It appears more evident that exacerbation of periodontal disease may occur in conjunction with poor glycemic control and that oral health evaluation remains an important aspect of overall management, especially for diabetes patients lacking good glycemic control. In contrast, based on our critical evaluation of the literature to date, current periodontal therapy strategies may offer only limited improvements, if any, in the glycemic status for patients with



**Fig. 5** Systematic review evaluation of study treatment effects of HbA1c relative to sample size and diabetes management (data based on Simpson et al. 2015). Treatment effects, with *negative numbers indicating decreased HbA1c following treatment*, are shown relative to study size and assessment of changes in diabetes medications during study (medications not assessed in blue, medications assessed in red)

diabetes mellitus. The “common soil” hypothesis may continue to provide for important considerations in this interplay between diseases, but it has yet to be shown to be the important factor suggested in numerous early reports regarding periodontal disease. Clearly, additional investigation with well-managed studies is required.

## Diabetes and Dental Implant Therapy

Dental implant therapy is now considered the standard of care when it comes to replacing missing teeth (Fig. 6). Previously, the options for replacing missing teeth were limited to either fixed or removable dentures. The removable options were either complete denture or removable partial dentures for missing teeth. The partial or complete denture requires patients to remove their prostheses for at least 8 hours a day. Removable prostheses are not always the best option as they offer significant compromises in oral health-related quality of life issues. The ability of dental implant therapy to provide a dramatic improvement in function is critical in consideration of masticatory function and nutrition. This directly impacts dietary management for patients with diabetes.





**Fig. 6** Surgical placement of dental implant. (a) Missing tooth #5, (b) radiographic image of missing tooth, (c) full thickness flap elevation of implant site presenting with adequate bone width, (d) implant placement in line with adjacent teeth, (e) 3 months post surgery with healing abutment in place, (f) radiographic image of implant in site (Surgeon NK)

A dental implant is defined as “an alloplastic material or device that is surgically placed into the oral tissue beneath the mucosal or periosteal layer or within the bone for functional, therapeutic, or esthetic purposes” (Glossary of Periodontal Terms 2001). This is typically a three-part restoration that includes surgical placement of implant in the jaw, followed by abutment (connector between implant and crown) and crown placement (Fig. 7). The tooth replacement could be single tooth or multiple teeth through an implant-supported bridge or implant-supported partial or complete removable overdenture.

The implants heal in direct contact with the bone by the process referred to as osseointegration. The term osseointegration refers to “direct contact, under light

**Fig. 7** Dental implant and crown showing relationship between implant surface with osseous tissue and oral mucosa. (From Carranza's *Clinical Periodontology* 11th ed. (Newman iii) Newman, Michael G. *Carranza's Clinical Periodontology, 11th Edition*. Saunders Book Company, 2012. VitalBook file. Fig. 68-5)



microscopic level between living bone tissue and an implant” (Glossary of Periodontal Terms 2001). It is the intimate contact between the bone and implant body that holds the restoration in place. Bone health hence plays a critical role in long-term success of the implant. A recent meta-analysis on bone turnover in diabetic patients concluded altered turnover rate, independent of glucose levels (Starup-Linde et al. 2014). Murine studies demonstrated altered bone physiology in hyperglycemic models (Funk et al. 2000; Amir et al. 2002; Lu et al. 2003). The changes in bone quality, compromised wound healing, and increased risk of infection (Pearl and Kanat 1988; Gallacher et al. 1995; McMahon and Bistran 1995; Delamaire et al. 1997; Shurtz-Swirski et al. 2001) have limited the indication of dental implants as viable treatment option for diabetic patients (Michaeli et al. 2009).

Animal and human studies have demonstrated success with dental implants as a treatment option in patients with good glycemic control (Siqueira et al. 2003; Peled et al. 2003; Farzad et al. 2002; Abdulwassie and Dhanrajani 2002; Olson et al. 2000; Balshi and Wolfinger 1999; Shernoff et al. 1994). A critical review of implant therapy for patients with diabetes by Oates et al. in 2013 identified 11 reports that demonstrated patient with good glycemic control to be considered for dental implant therapy. However, the definition of good glycemic control remains non-standardized in dental literature (Shernoff et al. 1994; Balshi and Wolfinger 1999; Fiorellini et al. 2000; Morris et al. 2000; Farzad et al. 2002; van Steenberghe et al. 2002; Moy et al. 2005). According to the review, most studies enrolled patients deemed as having

good glycemic control without any qualitative measurement and longitudinal assessments or, if so, they did not report on outcomes relative to glycemic levels (Balshi and Wolfinger 1999; Farzad et al. 2002). Glycemic control is best assessed using HbA1c reading (Koenig et al. 1976). Elevated levels of HbA1c have been correlated with complications in persons with type 2 diabetes mellitus (Cohen and Horton 2007). In 2010, according to the Standards of Medical Care in Diabetes, good glycemic control is correlated with HbA1c between 6.5% and 7.0% or less. This established the criteria for long-term evaluation of glycemic control in patients undergoing diabetic therapy.

Dental implant studies have also used fasting plasma glucose and postprandial glucose levels as glycemic control measurements (Abdulwassie and Dhanrajani 2002; Peled et al. 2003). These reports again do not provide a longitudinal assessment of glycemic control. Based on this review, the implant failure rate in diabetic patients ranged between 0% and 14.3%, and in patients with multiple implants, the possibility of having one failed implant ranged between 0% and 31.3% (Oates et al. 2013). Overall, these studies offer little guidance toward appropriate use of dental implant therapy for patients with diabetes.

Further confounding this issue, a primate study evaluating dental implants in hyperglycemic conditions demonstrated no change in osseointegration process (Casap et al. 2008). There have been few human dental implant studies done in patients with high levels of HbA1c (Dowell et al. 2007; Tawil et al. 2008; Oates et al. 2009; Turkyilmaz 2010; Khandelwal et al. 2013). It is noteworthy that these studies consistently demonstrated successful implant placement in hyperglycemic patients for which placement would otherwise not be indicated. The reports have shown successful implant placement with HbA1c readings over 13% (Dowell et al. 2007; Oates et al. 2009). Among these five studies that reported implant failures in poorly controlled diabetic patients, the failure rate ranged between 0% and 9.1%. However, limitations of the studies included a short-term follow-up period of 4 months for one having a 0% failure rate, and at the other extreme, the 9.1% failure rate was due to a single patient receiving 11 implants with 10 successful and only 1 failure.

More recently, Oates et al. (2014) reported on 117 patients with HbA1c levels ranging from 5.1% to 13.3% over 1 year following implant placement. The study included nondiabetic, controlled diabetic, and uncontrolled diabetic patients. Followed for 1 year after dental implant restoration, there was no difference in implant failure rates between patients with or without diabetes or with well-controlled or poorly controlled diabetes. These findings were reinforced in a second study that demonstrated successful implant placement in patients with both controlled and uncontrolled glycemic levels followed up for a year (Ghiraldini et al. 2016).

Current understanding of the biology underlying these implant outcomes has been extended through a novel application of dental implants and an assessment tool to measure implant stability using resonance frequency analysis (Osstell<sup>®</sup>) and by measuring levels of implant stability over time, allowing a glimpse into the effects of bone metabolism following implant placement (Barewal et al. 2003). The

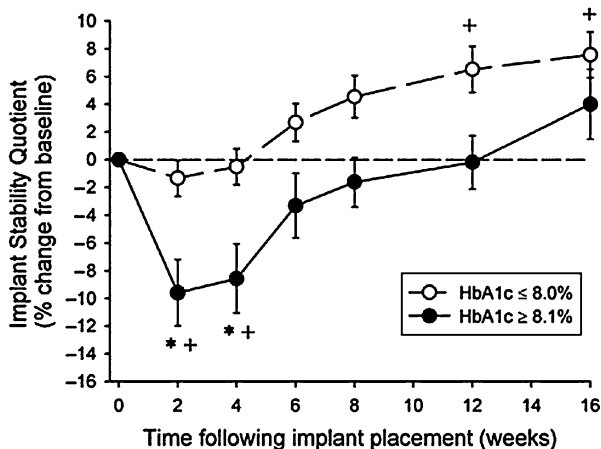

**Fig. 8** Changes in implant stability (negative change represents decreased osseous support for implant) as measured using resonance frequency analysis (Osstell®) over 16 weeks following implant placement. Significant differences between poorly controlled patients (HbA1c  $\geq 8.1\%$ ) and nondiabetic and well-controlled patients (HbA1c  $\leq 8.0\%$ ) in stability were seen at 2 and 4 weeks following placement. (From Oates et al. 2009, JDR)

longitudinal assessment of implant stabilization has allowed us to develop greater insights into human bone metabolism associated using this acute bone healing/implant integration model for patients with diabetes (Fig. 8; Oates et al. 2009, 2014). Importantly, these studies have demonstrated significant delays in implant integration under the cloak of high levels of clinical success. The findings of delays in bone healing following surgical placement of implants are consistent with many animal studies showing delays in bone formation, in particular with hyperglycemic conditions. These studies showed approximately a twofold increase in the time needed for the implants to return to a higher level of stability consistent with placement (Table 1). The HbA1c cutpoint for this delay was seen for patients with HbA1c levels over 8% at the time of implant placement. These delays extended osseous healing from 2.4 months to 5.4 months in the better implant healing conditions and from 3.8 months to 7.3 months in the worse implant healing conditions (Oates et al. 2014). It also appears from this study that once implant integration has been achieved, there are little changes noted in implant stability over longer periods of time.

Dental implants may suffer from a periodontal disease-like condition resulting in the loss of bone support. Peri-implantitis is inflammation of the tissue around the implant and its supporting bone. It is commonly seen in patients in the absence of a maintenance program (Roos-Jansåker et al. 2006). This peri-implantitis condition appears to be an inconsistent but real outcome of dental implant therapy. Importantly, Renvert and Polyzois (2015) showed a low prevalence rate of 5% of peri-implantitis for patients with well-controlled diabetes, consistent with the general population without diabetes.

**Table 1** Mean time for poorer performing and better performing implants to achieve an RFA  $\geq$  Baseline RFA (at surgery)<sup>a</sup>. (From Oates et al. 2014, Table 3)

HbA1c (%) at surgery	Number of patients	Time (months) to RFA $\geq$ Baseline RFA	
		Poorer performing implant <sup>a</sup>	Better performing implant <sup>a</sup>
		Mean (95% CI)	Mean (95% CI)
$\leq 5.9$	50	3.8 (2.3–5.4)	2.4 (1.0–3.9)
6.0–8.0	47	4.0 (2.4–5.6)	2.8 (1.3–4.3)
$\geq 8.1$	20	7.3 (4.9–9.8)	5.4 (3.1–7.7)
Significance		P = 0.0482 <sup>b</sup>	P = 0.0879 <sup>b</sup>
		P = 0.0144 <sup>c</sup>	P = 0.0309 <sup>c</sup>
		P = 0.8446 <sup>d</sup>	P = 0.6801 <sup>d</sup>

<sup>a</sup>In patients that were lost to follow-up prior to the RFA achieving an RFA  $\geq$  Baseline RFA, we assumed that the implant did not achieve such an RFA during the study period

<sup>b</sup>Test of differences among the three HbA1c groups

<sup>c</sup>Test of difference between HbA1c  $\leq 5.9$  and combined HbA1c 6.0–8.0

<sup>d</sup>Test of differences between HbA1c  $\leq 5.9$  and HbA1c 6.0–8.0

As implant therapy in uncontrolled diabetics is a relatively new concept, opportunities for further research exist based on the limited breadth of literature in the subject. This becomes important as the potential for patients with poorly controlled diabetes to suffer from worsening periodontal disease; similar mechanisms may be involved in the disruption of implant support, leaving diabetes patients particularly vulnerable. A recent review of studies evaluating implant survival over 2 or more years suggests that there is a dramatic increase in implant failures for patients with diabetes over time, with a retrospective study up to 21 years seeing over 30% of implant patients suffering at least one implant failure (Oates et al. 2013). As these findings suggest an increased vulnerability, there is a need for further research into this aspect but also a need for vigilance in maintaining the health of the implant-supporting tissues in this potentially vulnerable population.

The effect of chronic inflammation around implants may result in increased alveolar bone loss and jeopardize implant survival. Schwartz et al. (2001) reported high bone mineral density and higher fracture rates in diabetic women in comparison to nondiabetic patients. The reasoning was the reduced quality of bone in diabetic compared to nondiabetic patients. The potential for alterations in bone quality to support the successful long-term management of functional forces applied to dental implants remains to be determined. It is possible that altered bone quality in conjunction with excessive forces may disrupt the bone matrix ultimately leading to the loss of implant support.

Maintenance of dental implants in diabetic patients depends on a healthy environment in the oral cavity. Plaque control and control of other risk factors may improve the longevity of the implants and, while unknown specifically for patients with diabetes, represent important cautions to care. Additional risk factors to implant survival are smoking and active periodontal disease on adjacent teeth. Implant studies involving diabetic patients usually exclude smokers for this reason limiting

the understanding of this potential interaction; however, this remains a legitimate concern in practice. Patients with active periodontal disease are at risk for implant failure due to increase in periodontopathogens. These pathogens may use teeth as their reservoir (Botero et al. 2005; Renvert et al. 2007; Maruyama et al. 2014). Ghiraldini and his colleagues demonstrated lower osteogenic bone markers, including TGF- $\beta$  and osteocalcin, in peri-implant crevicular fluids collected from around implants in patients with hyperglycemia. This finding does suggest an altered sulcular environment with the potential for degradation of supporting tissues, reinforcing the need for careful maintenance of peri-implant tissues and implant itself.

Peri-implantitis is an undesirable complication as management of the disease process along with uncontrolled diabetes can become challenging. Corrective therapy includes surgical intervention along with additional grafting procedures to attempt reestablishment of lost peri-implant tissues. Success of peri-implantitis treatment, while guarded, is similar in diabetic patients to healthy patients.

Implant therapy offers improved function following loss of the patient's natural dentition. As diabetes is considered a risk factor to periodontal disease, it may contribute to tooth loss and compromised function (Oliver and Tervonen 1993). Diet is an important part of disease management for diabetic patients; hence restoring function becomes an essential part of the therapy (Quandt et al. 2009). Kapur et al. (1999) investigated impact of implant therapy on diet of diabetic patients. Their group reported improved chewing efficiency, denture stability, healthier food choices, and hence improvements in quality of life. In conclusion, dental implants can be considered as a viable option for diabetic patients and selectively in uncontrolled diabetic patients.

---

## Summary

Patients with diabetes mellitus are faced with a multitude of challenges to their health. It appears that compromises in oral health and periodontal disease represent a unique set of challenges to these patients. The increased severity of periodontal disease associated with poorly controlled diabetes along with subsequent tooth loss leads to compromises in quality of life for these patients, ranging from chewing function to self-esteem. While much has been studied regarding the potential for periodontal disease to worsen glycemic control, the benefits of periodontal therapy on glycemic status, as currently provided, appear minimal. However, recognizing the opportunities that do exist for oral health care to maintain or enhance the oral health quality of life is paramount. Minimizing tooth loss through careful maintenance and the use of implant therapy for tooth replacement remain important areas of contribution.

The potential for implant therapy to support these efforts, in particular in patients struggling with medical compliance, appears to be a great opportunity for oral health care to provide important contributions to the overall health of patients with diabetes. It is an opportunity the profession should not overlook.

## References

- Abdulwassie H, Dhanrajani PJ. Diabetes mellitus and dental implants: a clinical study. *Implant Dent.* 2002;11:83–6.
- Amir G, Rosenmann E, Sherman Y, Greenfeld Z, Ne'eman Z, Cohen AM. Osteoporosis in the Cohen diabetic rat: correlation between histomorphometric changes in bone and microangiopathy. *Lab Invest.* 2002;82(10):1399–405.
- Balshi TJ, Wolfinger GJ. Dental implants in the diabetic patient: a retrospective study. *Implant Dent.* 1999;8:355–9.
- Barewal RM, Oates TW, Meredith N, Cochran DL. Resonance frequency measurement of implant stability in vivo on implants with a sandblasted and acid-etched surface. *Int J Oral Maxillofac Implants.* 2003;18(5):641–51.
- Beck J, Garcia R, Heiss G, Vokonas PS, Offenbacher S. Periodontal disease and cardiovascular disease. *J Periodontol.* 1996;67(10 Suppl):1123–37.
- Botero JE, González AM, Mercado RA, Olave G, Contreras A. Subgingival microbiota in peri-implant mucosa lesions and adjacent teeth in partially edentulous patients. *J Periodontol.* 2005;76(9):1490–5.
- Botero JE, Yepes FL, Roldán N, et al. Tooth and periodontal clinical attachment loss are associated with hyperglycemia in patients with diabetes. *J Periodontol.* 2012;83:1245–50.
- Botero JE, Rodríguez C, Agudelo-Suarez AA. Periodontal treatment and glycaemic control in patients with diabetes and periodontitis: an umbrella review. *Aust Dent J.* 2016;61(2):134–48.
- Casap N, Nimri S, Ziv E, Sela J, Samuni Y. Type 2 diabetes has minimal effect on osseointegration of titanium implants in psammomys obesus. *Clin Oral Implants Res.* 2008;19:458–64.
- Chávarry NG, Vettore MV, Sansone C, Sheiham A. The relationship between diabetes mellitus and destructive periodontal disease: a meta-analysis. *Oral Health Prev Dent.* 2009;7:107–27.
- Cohen A, Horton ES. Progress in the treatment of type 2 diabetes: new pharmacologic approaches to improve glycaemic control. *Curr Med Res Opin.* 2007;23:905–17.
- Corbella S, Francetti L, Taschieri S, De Siena F, Fabbro MD. Effect of periodontal treatment on glycaemic control of patients with diabetes: a systematic review and meta-analysis. *J Diabetes Investig.* 2013;4(5):502–9.
- Costa FO, Miranda Cota LO, Pereira Lages EJ, Soares Dutra Oliveira AM, Dutra Oliveira PA, Cyrino RM, Medeiros Lorentz TC, Cortelli SC, Cortelli JR. Progression of periodontitis and tooth loss associated with glycaemic control in individuals undergoing periodontal maintenance therapy: a 5-year follow-up study. *J Periodontol.* 2013;84(5):595–605.
- Delamair M, Maugeudre D, Moreno M, Le Goff MC, Allannic H, Genetet B. Impaired leucocyte functions in diabetic patients. *Diabet Med.* 1997;14(1):29–34.
- Demmer RT, Papapanou PN. Epidemiologic patterns of chronic and aggressive periodontitis. *Periodontol 2000.* 2010;53:28–44.
- Dowell S, Oates TW, Robinson M. Implant success in people with type 2 diabetes mellitus with varying glycaemic control: a pilot study. *J Am Dent Assoc.* 2007;138:355–61.
- Emrich LJ, Shlossman M, Genco RJ. Periodontal disease in non-insulin-dependent diabetes mellitus. *J Periodontol.* 1991;62(2):123–31.
- Engelbreton SP et al. The effect of nonsurgical periodontal therapy on hemoglobin A1c levels in persons with type 2 diabetes and chronic periodontitis: a randomized clinical trial. *JAMA.* 2013;310(23):2523–32.
- Faggion CM Jr, Cullinan MP, Atieh M. An overview of systematic reviews on the effectiveness of periodontal treatment to improve glycaemic control. *J Periodontol Res.* 2016;51(6):716–25.
- Farzad P, Andersson L, Nyberg J. Dental implant treatment in diabetic patients. *Implant Dent.* 2002;11:262–7.
- Fiorellini JP, Chen PK, Nevins M, Nevins ML. A retrospective study of dental implants in diabetic patients. *Int J Periodontics Restorative Dent.* 2000;20:366–73.
- Funk JR, Hale JE, Carmines D, Gooch HL, Hurwitz SR. Biomechanical evaluation of early fracture healing in normal and diabetic rats. *J Orthop Res.* 2000;18(1):126–32.

- Gallacher SJ, Thomson G, Fraser WD, Fisher BM, Gemmell CG, MacCuish AC. Neutrophil bactericidal function in diabetes mellitus: evidence for association with blood glucose control. *Diabet Med*. 1995;12(10):916–20.
- Ghiraldini B, Conte A, Casarin RC, Casati MZ, Pimentel SP, Cirano FR, Ribeiro FV. Influence of glycemic control on peri-implant bone healing: 12-month outcomes of local release of bone-related factors and implant stabilization in type 2 diabetics. *Clin Implant Dent Relat Res*. 2016;18(4):801–9.
- Glossary of Periodontal Terms, 4th ed, Copyright 2001 by The American Academy of Periodontology, Suite 800, 737 North Michigan Avenue, Chicago, Illinois 60611-2690.
- Hajishengallis G. Immunomicrobial pathogenesis of periodontitis: keystones, pathobionts, and host response. *Trends Immunol*. 2014;35(1):3–11.
- Jiao Y, Hasegawa M, Inohara N. The role of oral pathobionts in dysbiosis during periodontitis development. *J Dent Res*. 2014;93(6):539–46.
- Kapp JM, Boren SA, Yun S, LeMaster J. Diabetes and tooth loss in a national sample of dentate adults reporting annual dental visits. *Prev Chronic Dis*. 2007;4(3):A59.
- Kapur KK, Garrett NR, Hamada MO, et al. Randomized clinical trial comparing the efficacy of mandibular implant-supported overdentures and conventional dentures in diabetic patients. Part III: comparisons of patient satisfaction. *J Prosthet Dent*. 1999;82(4):416–27.
- Kaur G, Holtfreter B, Rathmann W, Schwahn C, Wallaschofski H, Schipf S, Nauck M, Kocher T. Association between type 1 and type 2 diabetes with periodontal disease and tooth loss. *J Clin Periodontol*. 2009;36(9):765–74.
- Khader YS, Dauod AS, El-Qaderi SS, Alkafajei A, Batayha WQ. Periodontal status of diabetics compared with nondiabetics: a meta-analysis. *J Diabet Complications*. 2006;20:59–68.
- Khandelwal N, Oates TW, Vargas A, Alexander PP, Schoolfield JD, Alex McMahan C. Conventional SLA and chemically modified SLA implants in patients with poorly controlled type 2 Diabetes mellitus – a randomized controlled trial. *Clin Oral Implants Res*. 2013;24:13–9.
- Knight ET, Leichter JW, Tawse-Smith A, Thomson WM. Quantifying the association between self-reported diabetes and periodontitis in the New Zealand population. *J Periodontol*. 2015;86(8):945–54.
- Koenig RJ, Peterson CM, Jones RL, Saudek C, Lehrman M, Cerami A. Correlation of glucose regulation and hemoglobin A1c in diabetes mellitus. *N Engl J Med*. 1976;295:417–20.
- Kowall B, Holtfreter B, Völzke H, Schipf S, Mundt T, Rathmann W, Kocher T. Pre-diabetes and well-controlled diabetes are not associated with periodontal disease: the SHIP Trend Study. *J Clin Periodontol*. 2015;42(5):422–30.
- Lalla E, Papapanou PN. Diabetes mellitus and periodontitis: a tale of two common interrelated diseases. *Nat Rev Endocrinol*. 2011;7(12):738–48.
- Lalla E, et al. Periodontal changes in children and adolescents with diabetes: a case-control study. *Diabetes Care*. 2006;29:295–9.
- Lalla E, et al. Diabetes mellitus promotes periodontal destruction in children. *J Clin Periodontol*. 2007;34:294–8.
- Lamont RJ, Hajishengallis G. Polymicrobial synergy and dysbiosis in inflammatory disease. *Trends Mol Med*. 2015;21(3):172–83.
- Li Q, Hao S, Fang J, Xie J, Kong XH, Yang JX. Effect of non-surgical periodontal treatment on glycemic control of patients with diabetes: a meta-analysis of randomized controlled trials. *Trials*. 2015;16:291.
- López NJ, Uribe S, Martínez B. Effect of periodontal treatment on preterm birth rate: a systematic review of meta-analyses. *Periodontol 2000*. 2015;67(1):87–130.
- Lu H, Kraut D, Gerstenfeld LC, Graves DT. Diabetes interferes with the bone formation by affecting the expression of transcription factors that regulate osteoblast differentiation. *Endocrinology*. 2003;144(1):346–52.
- Maruyama N, Maruyama F, Takeuchi Y, Aikawa C, Izumi Y, Nakagawa I. Intraindividual variation in core microbiota in peri-implantitis and periodontitis. *Sci Rep*. 2014;13(4):6602.



- McMahon MM, Bistrrian BR. Host defenses and susceptibility to infection in patients with diabetes mellitus. *Infect Dis Clin North Am*. 1995;9(1):1–9.
- Mealey BL, Rethman MP. Periodontal disease and diabetes mellitus. Bidirectional relationship. *Dent Today*. 2003;22(4):107–13.
- Michaeli E, Weinberg I, Nahlieli O. Dental implants in the diabetic patient: systemic and rehabilitative considerations. *Quintessence Int*. 2009;40(8):639–45.
- Morris HF, Ochi S, Winkler S. Implant survival in patients with type 2 diabetes: placement to 36 months. *Ann Periodontol*. 2000;5:157–65.
- Moy PK, Medina D, Shetty V, Aghaloo TL. Dental implant failure rates and associated risk factors. *Int J Oral Maxillofac Implants*. 2005;20(4):569–77.
- Nelson RG, Shlossman M, Budding LM, Pettitt DJ, Saad MF, Genco RJ, Knowler WC. Periodontal disease and NIDDM in Pima Indians. *Diabetes Care*. 1990;13(8):836–40.
- Oates TW, Dowell S, Robinson M, McMahan CA. Glycemic control and implant stabilization in type 2 diabetes mellitus. *J Dent Res*. 2009;88:367–71.
- Oates TW, Huynh-Ba G, Vargas A, Alexander P, Feine J. A critical review of diabetes, glycemic control, and dental implant therapy. *Clin Oral Implants Res*. 2013;24(2):117–27.
- Oates TW, Galloway P, Alexander P, Vargas Green A, Huynh-Ba G, Feine J, McMahan CA. The effects of elevated hemoglobin A(1c) in patients with type 2 diabetes mellitus on dental implants: survival and stability at one year. *J Am Dent Assoc*. 2014;145(12):1218–26.
- Offenbacher S, Katz V, Fertik G, Collins J, Boyd D, Maynor G, McKaig R, Beck J. Periodontal infection as a possible risk factor for preterm low birth weight. *J Periodontol*. 1996;67(10 Suppl):1103–13.
- Oliver RC, Tervonen T. Periodontitis and tooth loss: comparing diabetics with the general population. *J Am Dent Assoc*. 1993;124(12):71–6.
- Olson JW, Shernoff F, Tarlow JL, Colwell JA, Scheetz JP, Bingham SF. Dental endosseous implant assessments in a type 2 diabetic population: A prospective study. *Int J Oral Maxillofac Implants*. 2000;15:811–21.
- Pearl SH, Kanat IO. Diabetes and healing: a review of the literature. *J Foot Surg*. 1988;27(3):268–70.
- Peled M, Ardekian L, Tagger-Green N, Gutmacher Z, Machtei EE. Dental implants in patients with type 2 diabetes mellitus: a clinical study. *Implant Dent*. 2003;12:116–22.
- Polyzos NP, Polyzos IP, Zavos A, Valachis A, Mauri D, Papanikolaou EG, Tzioras S, Weber D, Messinis IE. Obstetric outcomes after treatment of periodontal disease during pregnancy: systematic review and meta-analysis. *BMJ*. 2010;341:c7017. (need approval to use figure 6 from publication)
- Pranckeviciene A, Siudikiene J, Ostrauskas R, Machiulskiene V. Severity of periodontal disease in adult patients with diabetes mellitus in relation to the type of diabetes. *Biomed Pap Med Fac Univ Palacky Olomouc Czech Repub*. 2014;158(1):117–23.
- Preshaw PM, Alba AL, Herrera D, Jepsen S, Konstantinidis A, Makrilakis K, Taylor R. Periodontitis and diabetes: a two-way relationship. *Diabetologia*. 2012;55(1):21–31.
- Quandt SA, Bell RA, Snively BM, et al. Dietary fat reduction behaviors among African American, American Indian, and white older adults with diabetes. *J Nutr Elder*. 2009;28(2):143–57.
- Renvert S, Polyzos I. Risk indicators for peri-implant mucositis: a systematic literature review. *J Clin Periodontol*. 2015;42(Suppl 16):S172–86. <https://doi.org/10.1111/jcpe.12346>.
- Renvert S, Roos-Jansåker A-M, Lindahl C, Renvert H, Rutger Persson G. Infection at titanium implants with or without a clinical diagnosis of inflammation. *Clin Oral Implants Res*. 2007;18:509–16.
- Roos-Jansåker AM, Lindahl C, Renvert H, Renvert S. Nine- to fourteen- year follow-up of implant treatment. Part II: presence of peri-implant lesions. *J Clin Periodontol*. 2006;33(4):290–5.
- Schwartz AV, Sellmeyer DE, Ensrud KE, Cauley JA, Tabor HK, Schreiner PJ, Jamal SA, Black DM, Cummings SR. Older women with diabetes have an increased risk of fracture: a prospective study. *J Clin Endocrinol Metab*. 2001;86:32–8.

- Sherhoff AF, Colwell JA, Bingham SF. Implants for type II diabetic patients: interim report. VA implants in diabetes study group. *Implant Dent.* 1994;3:183–5.
- Shurtz-Swirski R, Sela S, Herskovits AT, Shasha SM, Shapiro G, Nasser L, Kristal B. Involvement of peripheral polymorphonuclear leukocytes in oxidative stress and inflammation in type 2 diabetic patients. *Diabetes Care.* 2001;24(1):104–10.
- Siqueira JT, Cavalher-Machado SC, Arana-Chavez VE, Sannomiya P. Bone formation around titanium implants in the rat tibia: role of insulin. *Implant Dent.* 2003;12:242–51.
- Simpson TC, Weldon JC, Worthington HV, Needleman I, Wild SH, Moles DR, Stevenson B, Furness S, Iheozor-Ejiofor Z. Treatment of periodontal disease for glycaemic control in people with diabetes mellitus. *Cochrane Database Syst Rev.* 2015;11:CD004714.
- Starup-Linde J, Eriksen SA, Lykkeboe S, Handberg A, Vestergaard P. Biochemical markers of bone turnover in diabetes patients – a meta-analysis, and a methodological study on the effects of glucose on bone markers. *Osteoporos Int.* 2014;25(6):1697–708.
- Stern MP. Diabetes and cardiovascular disease. The “common soil” hypothesis. *Diabetes.* 1995;44(4):369–74.
- Tawil G, Younan R, Azar P, Sleilati G. Conventional and advanced implant treatment in the type II diabetic patient: surgical protocol and long-term clinical results. *Int J Oral Maxillofac Implants.* 2008;23(4):744–52.
- Turkyilmaz I. One-year clinical outcome of dental implants placed in patients with type 2 diabetes mellitus: a case series. *Implant Dent.* 2010;19(4):323–9.
- van Steenberghe D, Jacobs R, Desnyder M, Maffei G, Quirynen M. The relative impact of local and endogenous patient-related factors on implant failure up to the abutment stage. *Clin Oral Implants Res.* 2002;13(6):617–22.



Maria Ida Maiorino, Giuseppe Bellastella, and  
Katherine Esposito

## Contents

Introduction .....	474
Erectile Dysfunction .....	474
ED and Diabetes: Epidemiology and Risk Factors .....	475
Physiology of Penile Erection .....	475
Pathogenesis of ED in Diabetes .....	476
Diagnosis .....	480
Treatment .....	481
Female Sexual Dysfunction .....	484
FSD and Diabetes: Epidemiology and Risk Factors .....	485
Physiology of Female Sexual Response .....	486
Pathogenesis of FSD in Diabetes .....	487
Diagnosis .....	488
Treatment .....	489
Summary .....	491
Appendix 1 .....	492
References .....	494

## Abstract

Sexual dysfunctions are common in diabetes mellitus, both in males and in females. Diabetes is an established risk factor for sexual dysfunction in men, as a threefold increased risk of erectile dysfunction was documented in diabetic men, compared with nondiabetic men. Among women, evidence regarding the association between diabetes and sexual dysfunction is less conclusive, as female sexual function appears to be more related to social and psychological components than to the physiological

---

M. I. Maiorino · G. Bellastella · K. Esposito (✉)  
Department of Advanced Medical and Surgical Sciences, University of Campania “Luigi  
Vanvitelli”, Naples, Italy  
e-mail: [mariaida.maiorino@unicampania.it](mailto:mariaida.maiorino@unicampania.it); [giuseppe.bellastella@unicampania.it](mailto:giuseppe.bellastella@unicampania.it);  
[katherine.esposito@unicampania.it](mailto:katherine.esposito@unicampania.it)

consequence of diabetes. The main mechanisms by which diabetes may lead to sexual dysfunctions include vasculopathy, neuropathy, endothelial dysfunction, visceral adiposity, endocrinological disorders, and psychological issues. An adequate comprehensive sexual and medical history investigation is of paramount importance for the evaluation of sexual dysfunctions in diabetes. Moreover, standardized questionnaires are frequently used to confirm the diagnosis and to measure its severity. Two of the most practical and easily administered ones are the International Index of Erectile Function (IIEF) and its short version, the IIEF-5, and the Female Sexual Function Index (FSFI) and its short version, the FSFI-6. Therapeutic possibilities for sexual dysfunctions in diabetes refer to lifestyle changes, optimal diabetic control, psychotherapy, and selected medications when appropriated.

---

**Keywords**

Diabetes mellitus · Erectile dysfunction · Hypogonadism · IIEF-5 · Female sexual dysfunction · FSFI · Diabetic complications

---

**Introduction**

Diabetes mellitus has been associated with sexual dysfunction, both in males and in females (Lindau et al. 2010). Diabetes is an established risk factor for sexual dysfunction in men, as a threefold increased risk of erectile dysfunction (ED) has been documented in diabetic compared with nondiabetic men. Among women, evidence regarding the association between diabetes and sexual dysfunction is less conclusive, although most studies have reported a higher prevalence of female sexual dysfunction (FSD) in diabetic women as compared with nondiabetic women. Hyperglycemia, which is a main determinant of microvascular diabetic complications, may participate in the pathogenetic mechanisms of sexual dysfunctions in diabetes. Moreover, diabetic people may present several clinical conditions, including hypertension, overweight and obesity, metabolic syndrome, cigarette smoking, and atherogenic dyslipidemia, which are themselves risk factors for sexual dysfunctions in both sexes.

---

**Erectile Dysfunction**

Erectile dysfunction is a common medical disorder defined as the inability to obtain or maintain a penile erection sufficient for a successful sexual intercourse, associated with decreased quality of life (McCabe et al. 2016). The prevalence of ED increases with age: it ranges from 1–10% in men younger than 40 years and increases to 20–40% between 60 and 69 years, reaching the highest rate in men older than 70 years (50–100%). As the aging population is growing, a corresponding increase in the number of men suffering from ED is expected. Both cross-sectional and longitudinal studies showed an association between ED and most of cardiovascular risk factors, including diabetes, smoking, hypertension, hyperlipidemia, metabolic syndrome, as

well as with depression, lower urinary tract symptoms, and poor health state (Shamloul and Ghanem 2013). Moreover, ED is a marker of significantly increased risk of cardiovascular disease (CVD), coronary heart diseases (CHD), and all-cause mortality.

## **ED and Diabetes: Epidemiology and Risk Factors**

Besides aging, diabetes is the most common risk factor for erectile dysfunction, which is reported to occur in >50% of men affected by diabetes worldwide. Epidemiological studies suggest that both type 1 and type 2 diabetes are associated with an increased risk of ED, as compared with the general population. In the Massachusetts Male Aging Study, a community-based, random sample observational survey aimed at defining the prevalence and correlates of erectile dysfunction in the general population, diabetic men showed a threefold probability of having ED than men without diabetes; moreover, the age-adjusted risk of erectile dysfunction was doubled in diabetic men than in those without diabetes. ED occurs 10–15 years earlier in men with diabetes; moreover, ED is more severe and less responsive to oral drugs in diabetes, leading to a poorer quality of life.

Both advancing age and longer duration of diabetes have been consistently associated with an increased risk of ED. Moreover, in diabetic men, the severity of ED increases with poor glycemic control and the presence of microvascular complications. Most of the clinical features associated with diabetes, including hypertension, hyperlipidemia, overweight and obesity, metabolic syndrome, smoking, sedentary lifestyle, and cardiovascular diseases, are well-recognized risk factors for ED (Giugliano et al. 2010). Several medications frequently assumed by diabetic patients, such as antihypertensive ( $\beta$ -blockers, thiazide diuretics, and spironolactone), psychotropic drugs (antidepressants), and certain fibrates, have been all associated with an additive deleterious effect on diabetic ED. A moderate consumption of alcohol (not more than 5% of the total daily caloric intake or  $\leq 7$  alcoholic drinks per week) may exert a protective effect on ED in both the general population and diabetic men.

## **Physiology of Penile Erection**

Penile erection is a complex mechanism resulting in penis tumescence, which begins after central processing and integration of visual, tactile, imaginative, and olfactory stimuli. An information network of primary afferents from the genitals, spinal interneurons, and sympathetic, parasympathetic, and somatic nuclei starts from the spinal cord. Peripherally, contraction (or relaxation) of the cavernosal smooth muscle controls the function of the penis, determining whether it is erect or flaccid.

Nitric oxide (NO), released from the endothelium and the parasympathetic nerve terminals, is the primary neurotransmitter involved in penile erection, although other transmitters can also be involved. NO-dependent relaxation of the cavernosal smooth muscles leads to compression of the subtunical small veins, occluding local venous return and resulting in an erection (Shamloul and Ghanem 2013).

Two intracellular mechanisms for relaxing the cavernosal smooth muscle can be identified: the guanylate cyclase (GS)/cGMP and adenylate cyclase/cAMP pathways. The first leads to the diffusion of NO into adjacent smooth muscle cells of the corpora cavernosa, where it binds to soluble guanylyl cyclase (GC), catalyzing the passage from guanosine triphosphate (GTP) to cGMP; this induces penile erection through decreasing cytosolic  $\text{Ca}^{2+}$  and increasing blood flow into the corpora cavernosa. The second involves prostaglandin E1 (PGE1). This activates the enzyme adenylate cyclase, catalyzing the conversion of adenosine monophosphate (AMP) to cyclic AMP (cAMP), which also decreases the intracellular  $\text{Ca}^{2+}$  (Fig. 1). Both cGMP and cAMP levels are modulated by phosphodiesterase (PDE) enzymes, which enable their respective transition to 5'GMP and 5'AMP. Phosphodiesterase 5 (PDE5) is an enzyme present in the NO/cGMP pathway which helps modulate smooth muscle cell relaxation and the erectile process. It is strongly expressed in the corpora cavernosa, in which the hydrolysis of cGMP to the inactive metabolite 5'GMP is promoted.

Penile detumescence begins with activation of the adrenergic receptors on the cavernous arteries and trabecular smooth muscles, leading to a reduction in arterial inflow and a collapse of lacunar spaces. Decompression of the drainage venules from the cavernous bodies occurs, allowing venous drainage of the lacunar spaces and relief of the erection.

## Pathogenesis of ED in Diabetes

Diabetic ED results from a combination of both organic and psychological factors, as well as relationship issues, which often coexist. Diabetes and the associated cardiovascular risk factors, including obesity, hyperlipidemia, hypertension, and smoking, are able to impair penile endothelial function, resulting in a decrease in endothelial-dependent corpora cavernosal smooth muscle relaxation through decreased expression and activity of both neuronal and endothelial NO synthase (nNOS, eNOS) and impaired NO release, causing the loss of NO bioactivity in the penis (Maiorino et al. 2014). Moreover, findings from studies conducted on experimental models of diabetes showed that type 1 and type 2 diabetes may differently affect vascular function in the penis. In type 1 diabetes, an impaired cavernosal vasodilation has been established, which appears to be mediated by a severe defect in non-adrenergic/non-cholinergic nerve signaling. In contrast, in type 2 diabetes, a striking increase in cavernosal contractile sensitivity and a significant veno-occlusive disorder occur, neither of which is consistently reported in type 1 diabetic animals. The proposed mechanisms of ED in diabetic men include hyperglycemia, vasculopathy, neuropathy, visceral obesity, hypogonadism, and psychological issues.

## Hyperglycemia

Four main molecular mechanisms have been implicated in glucose-mediated endothelial damage, leading to erectile dysfunction: increased polyol pathway flux, increased advanced glycation end product (AGE) formation, activation of protein kinase C (PKC) isoforms, and increased hexosamine pathway flux. All of them

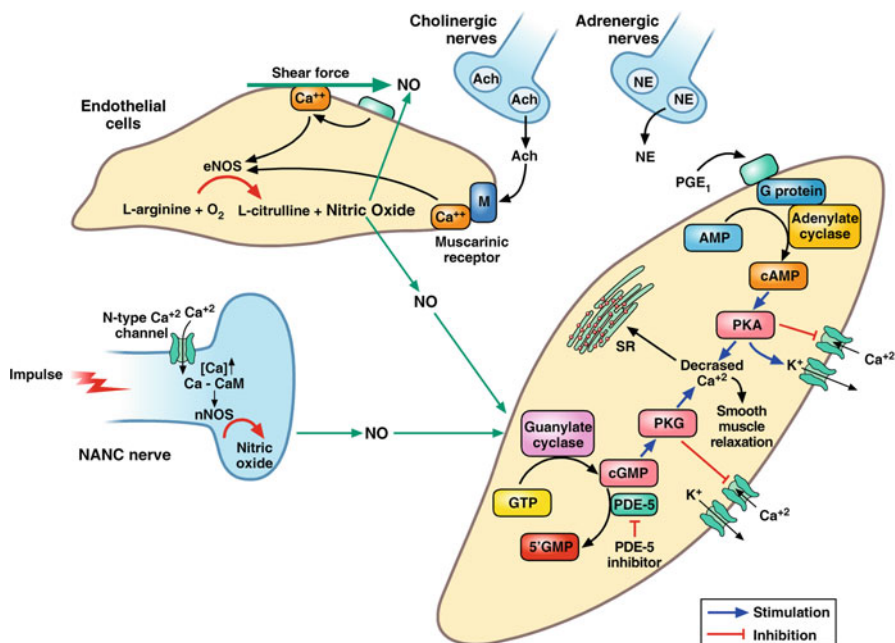
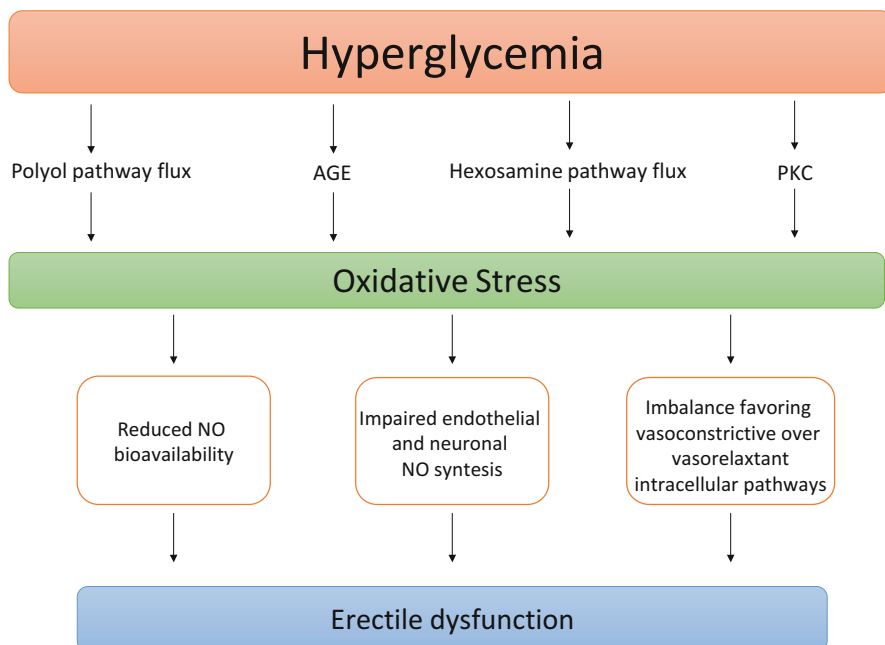

**Fig. 1** Mechanisms of penile erection. NO is the main mediator of penile smooth muscle relaxation. After sexual stimulation, NO concentration is released from the cholinergic and non-noradrenergic fibers, non-cholinergic fibers, and the endothelium. NO works by activation of the GTP/cGMP pathway, leading to the decrease of intracellular calcium and resulting in trabecular smooth muscle relaxation. PDE5 enzyme regulates cGMP-dependent penile erection by stimulating hydrolysis of cGMP itself. Another mechanism that can reduce intracellular calcium concentrations is mediated by cAMP. AMP adenosine monophosphate, Ach acetylcholine, cAMP cyclic adenosine monophosphate, cGMP cyclic guanosine monophosphate, eNOS endothelial nitric oxide synthase, GTP guanosine triphosphate, NANC non-adrenergic non-cholinergic, NE norepinephrine, nNOS neuronal nitric oxide synthase, NO nitric oxide, PDE5 phosphodiesterase 5, PGE1 prostaglandin E1, PKA protein kinase A, PKG protein kinase G. (Modified from Physiology 2013;28(4):262–269)

converge on the overproduction of oxygen free radicals by the mitochondrial electron transport chain, which reduces the bioavailability of NO; impairs endothelial and neuronal NO synthesis, expression, and activity; and produces imbalance between the vasoconstrictive and vasorelaxant intracellular pathways favoring increased vasoconstriction (Fig. 2).

## Vasculopathy

Diabetic vasculopathy concerns macroangiopathy and microangiopathy. Macrovascular disease in diabetes corresponds to the atherosclerotic damage of blood vessels, which limits the blood flow to the penis. As mentioned above, several cardiovascular risk factors associated with diabetes contribute to the genesis of penile arterial insufficiency: all of them converge on endothelial dysfunction, which represents the common denominator leading to vascular ED. Microvascular



**Fig. 2** Molecular pathways linking hyperglycemia to erectile dysfunction. *AGE* advanced glycation end products, *PKC* protein kinase C, *NO* nitric oxide

disease determines vascular injury of peripheral blood vessels and nerves, producing ischemic damage in the distal circulation and autonomic and peripheral neuropathy. Apoptosis and decreased regeneration of the endothelial monolayer are cellular mechanisms of endothelial dysfunction, possibly related to ED in diabetic men.

### Neuropathy

Diabetes is associated with both peripheral and autonomic neuropathy, and both of these can contribute to ED. The innervation of the penis occurs via the dorsal penile and perineal nerves, which carry sympathetic and parasympathetic autonomic nerves, as well as sensory and motor somatic nerves. The mechanism for ED in autonomic neuropathy is due to the reduced or absent parasympathetic activity needed for relaxation of the smooth muscle of the corpus cavernosum. Diabetes-associated peripheral neuropathy leads to impairment of sensory impulses from the shaft and the glans of the penis to the reflexogenic erectile center, reducing the venous outflow from the cavernous bodies.

### Visceral Adiposity

A large body of evidence indicates that central adiposity plays a key role in inflammation and endothelial function (Esposito and Giugliano 2011). Insulin resistance, endothelial dysfunction, and subclinical inflammation have all been



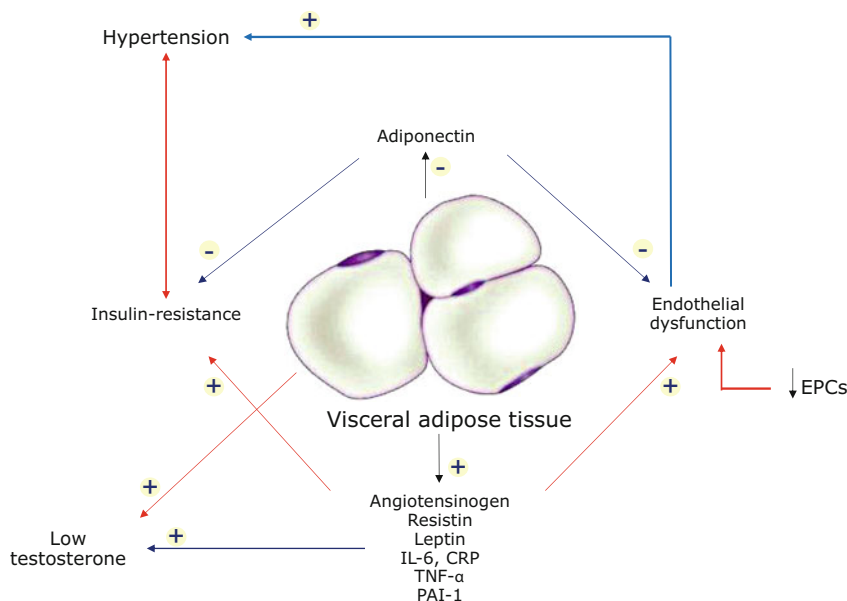

**Fig. 3** Visceral adipose tissue is a key component in regulation of inflammatory events which lead to endothelial dysfunction and low testosterone levels. *CRP* C-reactive protein, *EPCs* endothelial progenitor cells, *HDL* high-density lipoprotein, *IL-6* interleukin-6, *OxLDL* oxidized low-density lipoprotein, *PAI-1* plasminogen activator inhibitor-1, *TNF- $\alpha$*  tumor necrosis factor  $\alpha$

shown to be associated with obesity, and they may contribute to the pathogenesis of ED in diabetic men (Fig. 3). Visceral fat is an active secretory tissue producing inflammatory cytokines, adipokines, biochemical modulators, and other pro-inflammatory factors including interleukin (IL)-6, IL-1b, plasminogen activator inhibitor-1 (PAI-1), tumor necrosis factor (TNF)- $\alpha$ , angiotensinogen, vascular endothelial growth factor, and serum amyloid A. These factors contribute to systemic and peripheral vascular inflammation and dysfunction.

One potential mechanism of how visceral adiposity and inflammatory response modulate insulin sensitivity involves the release of free fatty acids. Free fatty acids activate nuclear factor-kB pathways resulting in increased synthesis of TNF- $\alpha$ . TNF- $\alpha$  further activates lipolysis as well as increased synthesis of IL-6 and macrophage chemoattractant protein-1, which increases recruitment of more macrophages and modulates insulin sensitivity. Increased production of TNF- $\alpha$  also enhances expression of adhesion molecules in both the endothelium and vascular smooth muscle cells. IL-6 stimulates hepatic synthesis of C-reactive protein, a nonspecific marker of vascular inflammation. In addition, TNF- $\alpha$  contributes to the dysregulation of insulin modulation of endothelin-1-mediated vasoconstriction and nitric oxide-mediated vasodilation, hence promoting vasoconstriction. Release of adipokines facilitates monocyte adhesion and migration into the vessel wall as well as the conversion of monocytes to macrophages. Aromatase, the enzyme that converts testosterone to

estradiol, is mainly located in adipose tissue. Moreover, obesity is associated with elevated estrogen in men activating hypothalamic estrogen receptors and inhibition of the hypothalamic-pituitary-gonadal axis, leading to low testosterone levels in diabetic and obese men.

In overweight subjects with ED, the reduction of endothelial progenitor cells, which participate in endothelial repair in case of vascular injury, may represent another mechanism linking visceral adipose tissue to endothelial dysfunction and consequently to reduced erectile function.

### **Hypogonadism**

Testosterone regulates nearly every component of erectile function, from pelvic ganglions to smooth muscle and the endothelial cells of the corpora cavernosa. It also modulates the timing of the erectile process as a function of sexual desire, coordinating penile erection with sex. Studies over the last few years have clearly established that at least 25% of men with type 2 diabetes have subnormal free testosterone concentrations in association with inappropriately low LH and FSH concentrations (Dandona and Dhindsa 2011). The mechanisms involved in testosterone deficiency in diabetes include low level of sex hormone-binding protein (SHBG) due to insulin resistance, increased aromatase activity in visceral adipose tissue leading to an augmented conversion of testosterone in estradiol, leptin resistance causing reduced secretion of LH and testosterone, increased level of inflammatory mediators which may suppress the secretion of GnRH and LH, and higher titers of antipituitary antibodies (APAs) against gonadotropin-producing cells, leading to hypogonadotropic hypogonadism.

### **Psychological Issues**

Diabetes and diabetic complications are associated with depression. Men with diabetes can have psychosexual and relationship issues predisposing them to develop ED just as in men without diabetes. The development of ED has been shown to worsen existing depressive symptoms, which suggests the possibility of a reinforcing mechanism. The attitude of the diabetic men and their partners toward chronic illness and its complications can also lead to sexual inhibition and arousal problems. Furthermore, the reduction in erectile function because of physical changes associated with diabetes can generate anxiety, making the condition worse. Men who have some difficulty with erectile function may need more physical stimulation. This may not be understood or appreciated by the partner who could attribute this to sexual disinterest or her own lack of attractiveness. These sequelae of events can lead to poor self-esteem and anxiety in both diabetic men and their partners, resulting in poor erectile function or worsening of existing ED.

### **Diagnosis**

An adequate and comprehensive sexual and medical history investigation is of paramount importance for the evaluation of ED in diabetes.

The presence of premature ejaculation and reduced libido should also be identified, as these three conditions are strongly interrelated and often associated. A full drug history should be taken. Diabetic complications, other conditions of comorbidity, and independent risk factors should be identified.

Standardized questionnaires are frequently used to confirm the diagnosis and to measure its severity. They are also valuable research tools that help assess the response to different treatments. Several questionnaires are available. Two of the most practical and easily administered ones are the International Index of Erectile Function (IIEF) and its short version, the IIEF-5, also known as the Sexual Health Inventory for Men (Corona et al. 2006). The IIEF is a 15-item self-report measure developed to assess erectile function in men in the general population. The IIEF measures function “over the past 4 weeks” in the following domains relevant to male sexuality: erectile function, orgasm, desire, intercourse satisfaction, and overall satisfaction. The IIEF-5, which consists of items 5, 15, 4, 2, and 7 from the full-scale IIEF, is limited to measuring erectile function and intercourse satisfaction in men. However, this instrument might be particularly valuable in settings where time constraints are highly significant. A sum score of 21 or less indicates the presence of ED (Appendix 1).

Recent findings that erectile dysfunction is a strong predictor of coronary artery diseases (CAD) and that the development of symptomatic erectile dysfunction might precede the occurrence of a cardiovascular event by 2–3 years have led to the need of a cardiovascular evaluation of patients who present with DE, including diabetic men. After a full medical assessment, the patient’s cardiovascular risk should be assessed with stratification to high-, medium-, or low-risk levels. After cardiovascular risk stratification, further assessment for the presence of silent CAD is of major importance (Nehra et al. 2012).

Physical examination, including general examination and blood pressure measurement, should be carried out. Examination of lower limbs for peripheral neuropathy and vasculopathy is relevant in diabetic men. Genital examination should be aimed at identifying balanitis and Peyronie’s disease and assessing secondary sexual characteristics, including testicular volume.

The assessment of glycemic control, lipid levels, a full blood count, renal function tests, and serum testosterone is recommended. Low concentrations of free or total testosterone necessitate further hormonal assessment, including that of LH, FSH, SHBG, and prolactin.

Second-line instrumental assessment includes intracavernosal injection and color Doppler ultrasound (for the evaluation of the vascular compartment) and nocturnal penile tumescence testing.

## Treatment

ED in diabetes is an evolutive condition, and no drugs are effective in arresting disease progression. As a consequence of its multifactorial etiology, the treatment of ED in diabetic men requires a global approach. The first step is to correct the

modifiable risk factors and to promote lifestyle changes, whereas the use of PDE5 inhibitors represents the first-line pharmacologic therapy.

### Lifestyle Changes

Lifestyle and nutrition have been recognized as central factors influencing both vascular NO production and erectile function. Moreover, it has also been suggested that lifestyle habits that decrease low-grade clinical inflammation may have a role in reducing the burden of sexual dysfunction (Esposito et al. 2004). Both basic and clinical studies have shown that targeting several lifestyle factors commonly associated with erectile dysfunction, such as smoking, alcohol consumption, obesity, and limited physical activity, can have significant effects on improvement of erectile function as well as testosterone levels. Interestingly, the abolition of cardiovascular risk factors is a desirable achievement in diabetes, leading to improvement of glycemic control and insulin resistance. Therefore, there may be a role for lifestyle measures to prevent progression or even enhance regression in the earliest manifestations of ED in diabetic men (Fig. 4).

Increased physical activity, healthy diet, and reduced caloric intake have been associated with the amelioration of erectile function in the general male population, as well as in diabetic men. Several prospective investigations indicate that physical activity has a beneficial effect on prevention and/or improvement of ED based on ameliorated cardiovascular fitness and endothelial dysfunction, increase in endothelial-derived NO, and decrease in oxidative stress. Moreover, physical exercise showed beneficial effects on self-esteem and mental health, with a positive impact on psychological issues associated with sexual dysfunction.

Dietary patterns with high content of whole grain foods and legumes, and vegetables and fruits, and that limit red meat, full-fat dairy products, and food and beverages high in added sugars are associated with a reduced risk of ED. The greater adherence to a Mediterranean-style diet, in particular, has been associated with a lower prevalence of ED in both diabetic and nondiabetic men in clinical trials.

**Fig. 4** Unhealthy lifestyle habits linked to erectile dysfunction. NO nitric oxide

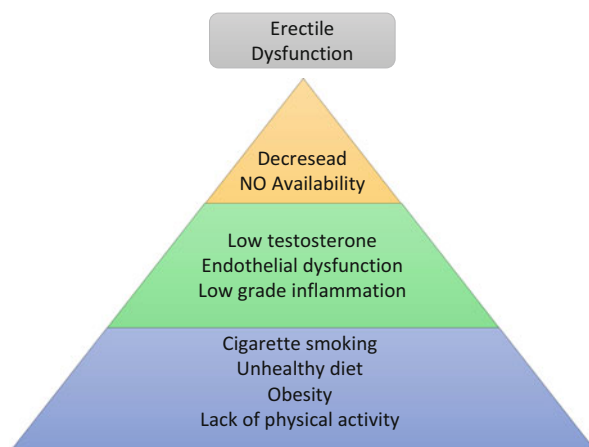

Both short- and long-term weight loss studies including only caloric modifications or restrictions demonstrated improvement of ED, and similar results were obtained with bariatric surgery-induced weight loss. Generally, a weight loss of 5–10% in overweight or obese diabetic men can result in effective improvement in erectile function in a short period of time (Maiorino et al. 2015).

The suggested mechanisms by which physical exercise, weight loss, and healthy diet can improve erectile function include the amelioration of endothelial dysfunction, insulin resistance, and low-grade inflammatory state associated with diabetes and metabolic diseases – all of which are risk factors for ED: the resulting improved inflammatory status may help contribute to reduce the burden of sexual dysfunction in men.

### Pharmacologic Therapy

PDE5 inhibitors (PDE5is) are currently the first-line treatment options for the majority of patients with ED based on their efficacy and safety profile (Hatzimouratidis et al. 2016). These include sildenafil, tadalafil, vardenafil, and avanafil, which are available worldwide; mirodenafil and udenafil, currently used only in Korea; and lodenafil, produced and available only in Brazil. These drugs promote erection by inhibiting the PDE5 enzyme, which is responsible for the degradation of cGMP in the cavernous smooth muscle. These inhibitions lead to the prolonged activity of cGMP, which in turn reduces intracellular calcium concentrations, maintains smooth muscle relaxation, and results in rigid penile erections. A large number of clinical trials have demonstrated the effectiveness of PDE5is in improving ED in diabetes, and they have been found to be generally safe and well tolerated (Vardi and Nini 2007). However, a high failure rate is reported if concomitant psychosexual, relational, and social factors are ignored. Nevertheless, several clinical trials found that the response to all PDE5is is lower in diabetic men as compared with nondiabetic men. While on-demand administration remains the first-line and most widely used approach, daily administration is a valuable alternative as it has been considered to be more effective in reverting endothelial dysfunction, the main pathogenetic component of ED in diabetes. Moreover, daily tadalafil is currently FDA- and EMA-approved for the treatment of ED and lower urinary tract symptoms. The latter indication is of particular interest, as it is a frequent complication in patients with diabetes. Coronary heart disease is not an absolute contraindication for PDE5is therapy, but particular caution has to be paid in case of unstable severe angina pectoris, recent myocardial infarction, certain arrhythmias, poorly controlled hypertension, and concomitant use of nitrates or nitrates donors: before starting therapy with PDE5is, diabetic patients should undergo an overall cardiovascular examination.

Testosterone replacement therapy (TRT) is recommended in diabetic men with ED and low levels of testosterone ( $\leq 12$  nmol/L) (Hatzimouratidis et al. 2016). Randomized controlled trials showed that TRT improved the metabolic profile and decreased visceral fat in diabetic men with hypogonadotropic hypogonadism.

Intracavernosal injection of papaverine, phentolamine, and prostaglandin E1 (PGE1), alone or in combination, and intraurethral administration of PGE1 are

good alternatives for patients who do not respond to PDE5 inhibitors (Hatzimouratidis et al. 2016). The most popular agent is alprostadil, which increases the concentration of cyclic adenosine monophosphate, leading to smooth muscle relaxation. Its easy administration via the dedicated applicator and the lack of any injection-related issues (needle/pain/difficulty) justify its place among second-line therapies in diabetes. However, intracavernosal injection of PGE1 is the oldest and still one of the most effective treatments for ED in diabetic patients, restoring erectile function in more than half of diabetic patients, as compared with placebo. Contraindications to such therapy include a history of priapism, sickle cell disease, multiple myeloma, and thrombocytopenia.

The implantation of a penile prosthesis is the most attractive surgical option for men for whom all other ED treatments were ineffective. The safety and efficacy of these devices have amply been demonstrated, with sufficiently low infection rates and durable long-term effectiveness even in high-risk diabetic patients.

---

## Female Sexual Dysfunction

Female sexual dysfunction (FSD) is a complex condition characterized by disturbances in the psychophysiological changes associated with the sexual response cycle in women, including disorders of sexual desire, arousal, orgasm, and pain. The general definition of FSD over the past decades has been dynamic, reflecting the ongoing changes in the conceptualization of sexual disorders. However, the classical medical definitions for FSD are generally accepted and have been provided by well-recognized medical resources (McCabe et al. 2016) (Table 1). The ICD-10 classification focuses on physical factors that influence sexual response. The *Diagnostic and Statistical Manual* (DSM-IV) underlines the emotional and psychological factors involved in FSD, and the most recent classification from the American Foundation of Urological Disease (AFUD) combines the previous classifications with the newest cyclic sexual response model proposed by Basson. More recently, the DSM-5 (*Diagnostic and Statistical Manual of Mental Disorders*) released newer and revised definitions, in which sexual desire and arousal disorders have been combined into “female sexual interest/arousal disorder” and vaginismus and dyspareunia have been grouped into the “genito-pelvic pain/penetration disorder.” Moreover, all of the DSM-5 sexual dysfunctions require a minimum duration of approximately 6 months and more precise severity criteria in order to provide useful thresholds for making a diagnosis and distinguish transient sexual difficulties from more persistent sexual dysfunction.

Sexual difficulties in women appear to be widespread in society, influenced by both health-related and psychosocial factors, and are associated with impaired quality of life and interpersonal relationships. Based on data of the National Health and Social Life Survey, which examined a cohort of US adults in 1992, prevalence of FSD has for many years been estimated at 43%, higher than that reported in men (31%). Large epidemiological studies reported that prevalence of FSD ranges from 40% to 60%, with the highest values in postmenopausal women. Common risk factor categories associated with sexual dysfunction in women include aging, diabetes

**Table 1** Definitions of sexual dysfunctions in women from the Fourth International Consultation on Sexual Medicine 2015

<b>Hypoactive sexual desire dysfunction</b>	Persistent or recurrent deficiency or the absence of sexual or erotic thoughts or fantasies and desire for sexual activity
<b>Female sexual arousal dysfunction</b>	Persistent or recurrent inability to attain or maintain arousal until completion of the sexual activity, an adequate subjective assessment of her genital response
<b>Female orgasmic dysfunction</b>	(i) Marked delay in, marked frequency of, or absence of orgasm and/or (ii) markedly decreased intensity of orgasmic sensation
<b>Female genital-pelvic pain dysfunction</b>	Persistent or recurrent difficulties with at least one of the following: (i) vaginal penetration during intercourse; (ii) marked vulvovaginal or pelvic pain during genital contact; (iii) marked fear or anxiety about vulvovaginal or pelvic pain in anticipation of, during, or as a result of genital contact; or (iv) marked hypertonicity or overactivity of pelvic floor muscles with or without genital contact
<b>Persistent genital arousal disorder</b>	Spontaneous, intrusive, and unwanted genital arousal (i.e., tingling, throbbing, pulsating) in the absence of sexual interest and desire. Any awareness of subjective arousal is typically, but not invariably, unpleasant. The arousal is unrelieved by at least one orgasm, and the feeling of arousal persists for hours or days
<b>Postcoital syndrome (postorgasmic illness syndrome)</b>	Negative feelings, experiences, and/or physical symptoms such as headache, malaise, fatigue, and other symptoms after sexual activity
<b>Hypohedonic orgasm</b>	Lifelong or acquired decreased or low level of sexual pleasure with orgasm
<b>Painful orgasm</b>	The occurrence of genital and/or pelvic pain during or shortly after orgasm

mellitus, cardiovascular disease, hypertension, concurrence of genitourinary disease, psychiatric/psychological disorders, cancer (Maiorino et al. 2016), and other chronic diseases. Moreover, limited social relations, financial difficulties, employment status, religious beliefs, educational background, and lack of exercise represent socio-cultural risk factors of FSD.

## FSD and Diabetes: Epidemiology and Risk Factors

FSD has been reported in diabetic women since the early 1980s. A high prevalence of FSD has been described in both type 1 and type 2 diabetic women, as compared with matched nondiabetic women. Moreover, correlates of sexual function seem different across the two main forms of diabetes: in type 2 diabetes, for instance, biological factors appear to play a major role, as FSD seems mainly related to obesity, metabolic syndrome, and microvascular complications (Esposito et al. 2010); on the other hand, in type 1 diabetes, FSD seems mainly related to menopausal status, depression, and marital status.

Age of diabetes onset is another critical point influencing women's sexual function. Women with type 2 diabetes viewed themselves as less attractive and less happy and reported less satisfaction with their sexual partner, sex life in general, lubrication, and orgasm. Type 1 diabetes is usually diagnosed during adolescence, before relationships are established; most women with type 1 diabetes have already received a diagnosis when undergoing sexual development and developing relationships. For these women, coping strategies begin early, and diabetes may be integrated more adequately into their lives, reducing its interference in sexual and marital relationships. In contrast, type 2 diabetes occurs later in life when relationships and sexual expectations are already established: this new diagnosis may potentially create marital tension and intimacy conflict, which ultimately leads to or exacerbates sexual problems. Therefore, psychological concerns may play a significant role in the development of FSD in both type 1 and type 2 diabetes. This is in line with the complexity of female sexuality, which is largely dependent on psychological and cultural factors than male sexuality.

## **Physiology of Female Sexual Response**

The human sexual response was initially described by Masters and Johnson as a linear process of distinct phases (excitement, arousal, orgasm, and resolution) and later modified by Kaplan into a three-phase model of desire, arousal, and orgasm. A more complex model of the female sexual response is now understood to include emotional and relational factors, as well as external and cognitive sexual stimuli.

Sex generally begins with desire, which can occur spontaneously or be stimulated externally or by way of cognitive motivation. External or cognitive incentives may include the desire to feel intimacy with one's partner, to experience sexual pleasure, to improve self-image, to relieve tension, to reduce guilt over sexual infrequency, or to conceive.

Sexual arousal includes both subjective excitement and physiological or genital arousal. These two are often distinct from one another, as healthy women with arousal disorder have shown normal genital vasocongestion in response to erotic stimuli despite complaints of low subjective arousal.

The two basic physiological reactions during the human sexual response are vasocongestion of the genitals and increased neuromuscular tension throughout the body. Increased blood flow to the genitalia results in vasocongestion, leading to vaginal lubrication and engorgement. The vagina lengthens and dilates due to relaxation of smooth muscle. Increased blood flow also results in engorgement and protrusion of the clitoris and vestibulovaginal bulbs and eversion of labia minora.

The normal female sexual response needs the integrity of both sensory and autonomic nervous system in order to respond to erotic stimuli and vascular districts which supply blood to external genitalia and vagina. Both smooth muscle relaxation



of female genitalia erectile tissue and enhancement of genital blood flow are dependent on the action of non-adrenergic/non-cholinergic neurotransmitters (NANC), such as vasoactive intestinal polypeptide (VIP) and NO. The regulation of blood flow and clitoral erectile function is governed by the same NO/cGMP pathway in women as erectile function is in men. NO and PDE5 have been identified in human clitoral smooth muscle, indicating a key role of nitric oxide in female sexual function. Normal levels of various hormones are also required for the physiologic sexual activity. Diabetes may affect all these integrated systems, leading to sexual dysfunction.

## **Pathogenesis of FSD in Diabetes**

Sexual problems in women with diabetes may be explained by several possible mechanisms, including biological, social, and psychological factors (Maiorino et al. 2014).

### **Hyperglycemia**

Hyperglycemia may reduce the hydration of mucous membranes in the vagina, leading to decreased lubrication and dyspareunia. Moreover, hyperglycemia increases the risk of vaginal infections, which in turn may lead to vaginal discomfort and dyspareunia.

### **Vascular and Nerve Dysfunctions**

Diabetes may impair sexual response by producing structural and functional changes in the female genitalia. Vascular endothelial dysfunction and its consequences are associated with CVD including coronary artery disease and peripheral vascular disease, leading to well-established sequelae of myocardial infarction and stroke. This process of vascular endothelial dysfunction in women may lead to impairment of the genital blood flow in the phases of female sexual function requiring appropriate arterial perfusion, especially sexual arousal. Studies in animals showed that diabetes may affect arousal and orgasmic sexual response by inducing impaired relaxation response of vaginal tissue to almost all transmitter systems, decreasing nerve-stimulated clitoral and vaginal blood flow, producing diffuse fibrosis of clitoris and vaginal tissues, and reducing muscular layer and epithelial thickness in the vagina. Diabetic neuropathy may further contribute to the pathogenesis of sexual dysfunctions by altering both the normal transduction of sexual stimuli and the triggered sexual response.

### **Endocrinological Disorders**

It has been hypothesized that FSD may be the consequence of imbalance in hormonal levels found in diabetic women, as indicated by epidemiological studies showing a correlation between alterations in the levels of androgens, estrogens, and SHBG and sexual problems in diabetic women. Moreover, several endocrinological pathologies associated with diabetes, such as thyroid disorders, hypothalamic-pituitary

dysfunctions, and polycystic ovarian syndrome, may further contribute to sexual dysfunctions in these women.

### **Psychological Factors**

Previous nationally representative studies demonstrate that sexual dysfunction is associated with poor health, with a well-recognized role of depression as determinant of sexual disorders in the female diabetic population. Most epidemiological studies showed that psychosocial factors are the main contributors to sexual dysfunctions in both type 1 and type 2 diabetes. Diabetic complications may also participate in affecting health and relationship status, quality of life, and woman's self-image, generating a vicious cycle which may have detrimental effects on sexual performance.

Sexual dysfunction is also a common side effect of treatment with antidepressants. Among women being treated, it has been found to be more common in those who take venlafaxine and SSRIs than bupropion or nefazodone.

### **Diagnosis**

The Food and Drug Administration, through the Center for Drug Evaluation and Research, published in 2000 a guidance document on female sexual dysfunctions which recognizes the importance of inventories and self-report measures in clinical and experimental practice. Moreover, the document clarifies that the definition of FSD should include a measurement of personal distress, reflecting a degree of psychorelational dissatisfaction. Therefore, the diagnosis of FSD can be made using validated questionnaires developed to investigate sexual function in the clinical setting. The Female Sexual Function Index (FSFI) is a 19-item self-report questionnaire with psychometric properties, originally developed to assess female sexual function in both pre- and postmenopausal women in the general population, investigating over the past 4 weeks the specific domains relevant to female sexuality: desire, arousal, lubrication, orgasm, satisfaction, and pain (Corona et al. 2006). A cutoff value of 26.55 is considered for the diagnosis of female sexual dysfunction, with the higher score indicating a better sexual function. Although the FSFI only takes a few minutes to complete, a recently developed shorter version of the measure is also available and further improves the likelihood of utilization. The FSFI six-item version takes approximately 3 min to complete and has good specificity and sensitivity values and the ability to discriminate between clinical and nonclinical populations (Isidori et al. 2010) (Appendix 1).

A comprehensive sexual history is essential in confirming the patient's diagnosis, as well as in the evaluation of the patient's overall sexual function. Attention should be paid to elements of the medical and surgical history that may be associated with sexual dysfunctions, as well as any medication or substance use that may affect sexual function.

A complete physical examination, including a focused pelvic examination, is important for identifying vaginal atrophy, infection, vulvar dermatoses, or pelvic

floor muscle dysfunction often associated with diabetes. A normal pelvic examination can also be reassuring and informative to a patient.

Recommended laboratory tests for women with sexual problems typically include fasting glucose, cholesterol, lipids, and hormonal profile, including thyroid function, gonadotropins, sexual steroids, based on the medical history and clinician's judgment.

## **Treatment**

At present, no specific guidelines are currently available for treatment of FSD in diabetes. Therefore, therapeutic possibilities for sexual dysfunction in diabetic women refer to the same strategy suggested for nondiabetic women, including lifestyle changes, optimal diabetic control, psychotherapy, and selected medications when appropriated. Due to its multifactorial etiology, a quite large variety of treatments addressing specific symptoms are available for FSD, but no treatment exists that addresses the overall disorder.

## **Lifestyle Change**

Both physical activity and healthy diet, such as Mediterranean diet, have been reported as useful strategies to reduce the risk and the worsening of FSD in diabetic patients.

Establishing and maintaining regular physical activity (for adult, at least 150 min/week of moderate intensity activity) can provide many health benefits. Strong evidence shows that regular physical activity helps people maintain a healthy weight, prevent excessive weight gain, lose weight when combined with a healthy eating pattern lower in calories, reduce depression, and prevent falls, all desirable achievements in diabetic women with sexual dysfunction.

Evidence shows that healthy eating patterns are associated with positive health outcomes. Within this body of evidence, higher intakes of vegetables and fruits have been identified as characteristics of healthy eating patterns; whole grains have been identified as well, although with slightly less consistency. Other characteristics of healthy eating patterns have been identified with less consistency and include fat-free or low-fat dairy, seafood, legumes, and nuts. Lower intakes of meats, including processed meats; processed poultry; sugar-sweetened foods, particularly beverages; and refined grains, have often been identified as characteristics of healthy eating patterns.

Mediterranean-style diet has been indicated by different major health organizations as a healthy eating pattern, demonstrating effectiveness in ameliorating cardiovascular risk and glycemic control in diabetes. High consumption of foods of vegetable origin, such as cereals and whole grains, fruits, vegetables, legumes, nuts, and olive oil as the principal source of fat; fish and poultry consumed in low-to-moderate amounts; relatively low consumption of red meat; and moderate consumption of wine, normally with meals, could be considered important characteristics of this dietary pattern. There is evidence from small randomized controlled trials that

Mediterranean diet may reduce FSD in women with type 2 diabetes or metabolic syndrome (Esposito et al. 2007).

Adoption of healthy lifestyles may reduce insulin resistance, endothelial dysfunction, and oxidative stress; the resulting improved well-being may further contribute to reduce and prevent sexual dysfunction in diabetic women.

### **Hormonal Therapy**

Decreased estrogen levels affect all four categories of FSD, including desire, arousal, orgasm, and pain. Diabetic women are at risk of vulvovaginal atrophy (VVA), characterized by dry, fragile vaginal tissue that is susceptible to injury and bleeding during intercourse. The available data do not support systemic estrogen therapy for the treatment of female sexual dysfunction. Topical vaginal estrogen therapy is considered first-line treatment of VVA in postmenopausal women. Oral ospemifene, a selective estrogen receptor modulator, is effective for the treatment of VVA and might have independent systemic effects on female sexual function. Local estrogen can be applied in the form of a vaginal suppository, cream, or in time-release ring that is replaced quarterly. Although the benefits of vaginal estrogen are numerous in patients with FSD, it is important to identify the long-term risks associated with its use: importantly, in women with diabetes, the effects of estrogens on lipid profile should be taken into account.

Although the exact mechanism of testosterone effects on FSD has not been elucidated, testosterone has a positive effect on women's sexual function, particularly in women affected by hypoactive sexual desire disorder. However, approved testosterone formulations for women are generally unavailable. In consequence, the prescribing of testosterone mostly involves off-label use of testosterone-based products formulated for men and individually compounded testosterone formulations.

### **Other Drugs**

In August 2015, the US Food and Drug Administration (FDA) approved flibanserin as a medical treatment for hypoactive sexual desire disorder (HSDD) in premenopausal women. Flibanserin acts by altering the neurotransmitter levels responsible for sexual excitement. By increasing dopamine and norepinephrine levels and decreasing serotonin levels, it increases sexual excitement while decreasing sexual inhibition, ultimately leading to improvement of a multitude of FSD symptoms (Katz et al. 2013). Major safety concerns regarding flibanserin include risks of hypotension, syncope, and central nervous system (CNS) depression (e.g., somnolence).

Acting on nitric oxide-mediated smooth muscle relaxation to increase vasodilatation, PDE5 inhibitors might theoretically improve vaginal lubrication and vulvar engorgement. Generally, the use of PDE5is resulted in significant improvements in sexual function compared with placebo, with some studies demonstrating negative results.

### **Mechanical Device**

Mechanical devices work in a variety of ways to treat FSD symptoms of arousal disorders, primarily working through vibratory stimulation or clitoral vascular

engorgement. Mechanical vibrators have long been used to aid in inducing clitoral engorgement. The vibrators stimulate the dorsal nerves, resulting in increased blood flow to the clitoris and sexual arousal. When vibrators fail in patients who have poor blood flow to the dorsal nerves, vacuum pump devices may be used. Vacuum pump devices are designed to increase blood flow to the clitoris by negative pressure, which leads to clitoral engorgement and ultimately improved sexual arousal and overall sexual satisfaction.

A potential treatment modality for FSD is the use of sacral neuromodulation (InterStim<sup>®</sup>). Sacral nerve stimulation has been used for almost two decades for overactive bladder, and there has been anecdotal evidence of an impact of these devices on FSD symptoms.

Dilators, also known as vaginal trainers, are meant to help relieve the anxiety associated with vaginal penetration. The treatment goal is to desensitize the woman to vaginal penetration with larger vaginal trainers.

### **Psychological Issue Treatment**

Cognitive behavioral psychotherapy is the proposed treatment for women suffering from desire disorders or vaginismus, while couple therapy has been proven to result in greater partner intimacy. Treatment of depression is crucial for the diabetic women with sexual dysfunction, while appropriate and specific antidepressive medications are beneficial. Frequently, since improvement of the glycemic control tends to improve depressive symptoms, antidepressive medications can be discontinued.

---

### **Summary**

Sexual dysfunctions are common in diabetes mellitus, both in males and in females. Diabetic people may present several clinical conditions, including hypertension, overweight and obesity, metabolic syndrome, cigarette smoking, and atherogenic dyslipidemia, which are themselves risk factors for sexual dysfunction. Moreover, vasculopathy, neuropathy, endothelial dysfunction, endocrinological disorders, and psychological issues are other potential mechanisms linking diabetes to sexual dysfunctions. Therefore, men and women with diabetes should be screened for sexual dysfunctions. In the clinical setting, the use of self-administered questionnaires helps clinicians to detect these conditions. As a consequence of their multifactorial etiology, the treatment of sexual dysfunctions in diabetic men and women requires a global approach. The first step is to correct the modifiable risk factors and to promote lifestyle changes, including healthy diet and physical activity. The use of PDE5 inhibitors represents the first-line pharmacologic therapy for ED. Flibanserin is the first approved drug for hypoactive sexual desire disorder (HSDD) in premenopausal women. Addressing psychological issues may be beneficial, resulting in greater couple well-being.

# Appendix 1

## The International Index of Erectile Function – 5 (IIEF-5)

Please encircle the response that best describes you for the following five questions:

<b>Over the past 6 months:</b>					
<b>How do you rate your confidence that you could get and keep an erection?</b>	Very low	Low	Moderate	High	Very high
	1	2	3	4	5
<b>When you had erections with sexual stimulation, how often were your erections hard enough for penetration?</b>	Almost never/never	A few times (much less than half the time)	Sometimes (about half the time)	Most times (much more than half the time)	Almost always/always
	1	2	3	4	5
<b>During sexual intercourse, how often were you able to maintain your erection after you had penetrated (entered) your partner?</b>	Almost never/never	A few times (much less than half the time)	Sometimes (about half the time)	Most times (much more than half the time)	Almost always/always
	1	2	3	4	5
<b>During sexual intercourse, how difficult was it to maintain your erection to completion of intercourse?</b>	Extremely difficult	Very difficult	Difficult	Slightly difficult	Not difficult
	1	2	3	4	5
<b>When you attempted sexual intercourse, how often was it satisfactory for you?</b>	Almost never/never	A few times (much less than half the time)	Sometimes (about half the time)	Most times (much more than half the time)	Almost always/always
	1	2	3	4	5

**Total Score:** \_\_\_\_\_

1-7: Severe ED

8-11: Moderate ED

12-16: Mild-moderate ED

17-21: Mild ED

22-25: No ED

**The Female Sexual Function Index – 6 (FSFI-6)**

Please encircle the response that best describes you for the following six questions:

<b>Over the past 4 weeks:</b>						
How would you rate your level (degree) of sexual desire or interest?		Very high	High	Moderate	Low	Very low
		5	4	3	2	1
How would you rate your level of sexual arousal (“turn on”) during sexual activity or intercourse?	No sexual activity	Very high	High	Moderate	Low	Very low
	0	5	4	3	2	1
How often did you become lubricated (“wet”) during sexual activity or intercourse?	No sexual activity	Almost always/always	Most time	Sometimes	A few times	Almost never or never
	0	5	4	3	2	1
When you had sexual stimulation or intercourse, how often did you reach orgasm?		Almost always/always	Most time	Sometimes	A few times	Almost never or never
		5	4	3	2	1
How satisfied have you been with your overall sexual life?		Very satisfied	Moderately satisfied	About equally satisfied and dissatisfied	Moderately dissatisfied	Very dissatisfied
		5	4	3	2	1
How often did you experience discomfort or pain during vaginal penetration?	Did not attempt Intercourse	Almost never or never	A few times	Sometimes	Most time	Almost always/always
	0	5	4	3	2	1

**Total Score:** \_\_\_\_\_

Total score <19: FSD

*FSD, female sexual dysfunction*

## References

- Corona G, Jannini EA, Maggi M. Inventories for male and female sexual dysfunctions. *Int J Impot Res*. 2006;18:236–50.
- Dandona P, Dhindsa S. Update: hypogonadotropic hypogonadism in type 2 diabetes and obesity. *J Clin Endocrinol Metab*. 2011;96:2643–51.
- Esposito K, Giugliano D. Obesity, the metabolic syndrome, and sexual dysfunction in men. *Clin Pharmacol Ther*. 2011;90:169–73.
- Esposito K, Giugliano F, Di Palo C, et al. Effect of lifestyle changes on erectile dysfunction in obese men: a randomized controlled trial. *JAMA*. 2004;291:2978–84.
- Esposito K, Ciotola M, Giugliano F, et al. Mediterranean diet improves sexual function in women with the metabolic syndrome. *Int J Impot Res*. 2007;19:486–91.
- Esposito K, Maiorino MI, Bellastella G, Giugliano F, Romano M, Giugliano D. Determinants of female sexual dysfunction in type 2 diabetes. *Int J Impot Res*. 2010;22:179–84.
- Giugliano F, Maiorino M, Bellastella G, Gicchino M, Giugliano D, Esposito K. Determinants of erectile dysfunction in type 2 diabetes. *Int J Impot Res*. 2010;22:204–9.
- Hatzimouratidis K, Salonia A, Adakian G, et al. Pharmacotherapy for erectile dysfunction: recommendations from the fourth international consultation for sexual medicine (ICSM 2015). *J Sex Med*. 2016;13:465–88.
- Isidori AM, Pozza C, Esposito K, et al. Development and validation of a 6-item version of the female sexual function index (FSFI) as a diagnostic tool for female sexual dysfunction. *J Sex Med*. 2010;7:1139–46.
- Katz M, DeRogatis LR, Ackerman R, Hedges P, Lesko L, Garcia M Jr, Sand M, BEGONIA trial investigators. Efficacy of flibanserin in women with hypoactive sexual desire disorder: results from the BEGONIA trial. *J Sex Med*. 2013;10:1807–15.
- Lindau ST, Tang H, Gomero A, Vable A, Huang ES, Drum ML, Qato DM, Chin MH. Sexuality among middle-aged and older adults with diagnosed and undiagnosed diabetes: a national, population-based study. *Diabetes Care*. 2010;33(10):2202–10.
- Maiorino MI, Bellastella G, Esposito K. Diabetes and sexual dysfunction: current perspectives. *Diabetes Metab Syndr Obes*. 2014;7:95–105.
- Maiorino MI, Bellastella G, Esposito K. Lifestyle modifications and erectile dysfunction: what can be expected? *Asian J Androl*. 2015;17:5–10.
- Maiorino MI, Chiodini P, Bellastella G, Giugliano D, Esposito K. Sexual dysfunction in women with cancer: a systematic review with meta-analysis of studies using the female sexual function index. *Endocrine*. 2016;54:329–41.
- McCabe MP, Sharlip ID, Atalla E, et al. Definitions of sexual dysfunctions in women and men: a consensus statement from the fourth international consultation on sexual medicine 2015. *J Sex Med*. 2016;13:135–43.
- Nehra A, Jackson G, Miner M, et al. The Princeton III Consensus recommendations for the management of erectile dysfunction and cardiovascular disease. *Mayo Clin Proc*. 2012;87:766–78.
- Shamloul R, Ghanem H. Erectile dysfunction. *Lancet*. 2013;381(9861):153–65.
- Vardi M, Nini A. Phosphodiesterase inhibitors for erectile dysfunction in patients with diabetes mellitus. *Cochrane Database Syst Rev*. 2007:CD002187.





Giovanni Targher, Alessandro Mantovani, and Enzo Bonora

## Contents

Introduction .....	496
Diagnosis of NAFLD .....	497
Epidemiology and Natural History of NAFLD in Patients with Diabetes .....	499
Association Between NAFLD and Poor Glycemic Control .....	500
Association Between NAFLD and Risk of Liver-Related Mortality and Morbidity .....	501
Association Between NAFLD and Risk of Chronic Kidney Disease and Other Microvascular Diabetic Complications .....	503
Association Between NAFLD and Risk of Cardiovascular, Cardiac, and Arrhythmic Complications .....	505
Putative Mechanisms Linking NAFLD with Cardiovascular, Cardiac, and Kidney Complications .....	508
Management of NAFLD in Patients with Diabetes .....	509
Treatment Options for NAFLD in Patients with Diabetes .....	512
Summary .....	518
References .....	519

## Abstract

Type 2 diabetes and nonalcoholic fatty liver disease (NAFLD) are common diseases that often coexist and may act synergistically to drive adverse hepatic and extrahepatic clinical outcomes. NAFLD affects up to 70–75% of patients with type 2 diabetes and approximately 30–40% of adult patients with type 1

G. Targher (✉) · A. Mantovani

Section of Endocrinology, Diabetes and Metabolism, Department of Medicine, University of Verona, Verona, Italy

e-mail: [giovanni.targher@univr.it](mailto:giovanni.targher@univr.it)

E. Bonora

Division of Endocrinology, Diabetes and Metabolism, University and Hospital Trust of Verona, Verona, Italy

e-mail: [enzo.bonora@univr.it](mailto:enzo.bonora@univr.it)

diabetes. In patients with diabetes, the presence of NAFLD is associated with poorer glycemic control, more severe hyperinsulinemia, atherogenic dyslipidemia, and adipose tissue/hepatic insulin resistance compared with patients without NAFLD. The coexistence of NAFLD and diabetes increases the risk of developing both microvascular and macrovascular complications of diabetes as well as increasing the risk of developing more severe forms of NAFLD (nonalcoholic steatohepatitis, advanced fibrosis, and cirrhosis). In addition, patients with NAFLD and diabetes have an increased risk of all-cause and cause-specific (cardiovascular, cancer, and liver) mortality compared with those without NAFLD. The mainstay of NAFLD management among patients with diabetes is currently to maintain a healthy body weight, improve glycemic control, and reduce the modifiable cardiometabolic risk factors. This chapter briefly discusses the diagnosis of NAFLD, the epidemiology and natural history of NAFLD in patients with diabetes, the potential adverse effects of NAFLD on glycemic control, and the risk of chronic complications of diabetes (principally cardiovascular disease and chronic kidney disease). This chapter also critically evaluates the available treatment options for NAFLD, with the aim of helping to inform the reader as to the most pertinent issues when managing patients with coexistent NAFLD and diabetes.

---

**Keywords**

Fatty liver · Nonalcoholic fatty liver disease · NAFLD · NASH · Diabetes · Complications

---

## Introduction

Nonalcoholic fatty liver disease (NAFLD) is increasingly diagnosed in many developed and developing countries, affecting about 25–30% of adults in the general population in Western countries, and is the most common cause of chronic liver disease among patients with type 2 diabetes (T2DM), occurring in up to 70–75% of these patients. In addition, NAFLD is likely to be the major underlying etiology for liver transplantation by 2020 in Western countries (Chalasani et al. 2012; Lonardo et al. 2015; EASL-EASD-EASO clinical practice guidelines 2016).

NAFLD is a spectrum of liver diseases that encompasses simple fatty infiltration in >5% of hepatocytes (simple steatosis or NAFL), fatty infiltration plus inflammation (nonalcoholic steatohepatitis, NASH), fibrosis, and ultimately cirrhosis that may sometimes progress to hepatocellular carcinoma (Chalasani et al. 2012; EASL-EASD-EASO clinical practice guidelines 2016).

NAFLD is strongly associated with abdominal overweight or obesity, insulin resistance, and other features of the metabolic syndrome. Given these strong associations, it is unsurprising that there is also a link between NAFLD and T2DM. In recent years, many studies have clearly demonstrated that NAFLD is associated with a substantially increased risk of all-cause and cause-specific (cardiovascular-, cancer-, and liver-related) mortality in patients with T2DM. In addition, accumulating evidence suggests that NAFLD can be directly implicated in the

development and progression of chronic complications of diabetes (mainly cardiovascular disease [CVD] and chronic kidney disease [CKD]) (Anstee et al. 2013; Byrne and Targher 2015; EASL-EASD-EASO clinical practice guidelines 2016).

This chapter will briefly discuss the diagnosis of NAFLD, the epidemiology and natural history of NAFLD in patients with diabetes, the evidence linking NAFLD with poorer glycemic control, and the prognostic role of NAFLD in the development of chronic vascular complications of diabetes. The management of NAFLD in patients with diabetes as well as the current and potential future pharmacological options for this increasingly prevalent liver disease that is likely to have an important future global impact on the burden of ill health will also be discussed.

---

## Diagnosis of NAFLD

Diagnosis of NAFLD is based on the following criteria: hepatic steatosis on imaging or histology, no excessive alcohol consumption (a threshold of 30 g/day for men and 20 g/day for women is conventionally adopted), and no competing causes for hepatic steatosis (e.g., virus, drugs, iron overload, autoimmunity) (Anstee et al. 2013; Chalasani et al. 2012; EASL-EASD-EASO clinical practice guidelines 2016).

The “gold standard” for the diagnosis of NAFLD remains liver biopsy, as this method is quantitative and is the only reliable way to assess disease severity within the spectrum of pathologic conditions that encapsulate NAFLD (simple steatosis, NASH, and cirrhosis). However, liver biopsy is invasive, potentially risky, patient-unfriendly, and subject to sampling error; therefore, this procedure is not suitable for the diagnosis of NAFLD in large cohorts or for patient monitoring (Chalasani et al. 2012; Rinella 2015; EASL-EASD-EASO clinical practice guidelines 2016).

Although liver ultrasonography remains the recommended first-line imaging modality in clinical practice, this imaging method provides a subjective and qualitative assessment of hepatic fat content, generally believed to be of only limited sensitivity (60–90%) when less than 20–30% of hepatocytes are steatotic (Chalasani et al. 2012; EASL-EASD-EASO clinical practice guidelines 2016). Computed tomography can also be used for diagnosing hepatic steatosis. The liver attenuation index is derived and defined as the difference between mean hepatic and mean splenic attenuation, and some investigators have used a liver attenuation index  $<5$  Hounsfield units to identify  $>5\%$  liver fat and diagnose NAFLD. To date, T1-weighted dual-echo magnetic resonance imaging and proton magnetic resonance spectroscopy have the best diagnostic accuracy in defining hepatic steatosis. Proton magnetic resonance spectroscopy enables quantitative assessment of hepatic triglyceride content (and potentially lipid composition) and has excellent reproducibility and sensitivity, but is resource intensive and still cannot reliably discriminate simple steatosis from NASH (Chalasani et al. 2012; EASL-EASD-EASO clinical practice guidelines 2016).

Hepatic steatosis is often associated with mild-to-moderate elevations of serum liver enzymes (mainly serum alanine aminotransferase and gamma-glutamyl-transferase levels), but, at best, the serum liver enzymes levels only identify people who are at increased risk of NAFLD and who will require further diagnostic tests.

A common clinical concern in patients with NAFLD is whether they have simple steatosis or NASH and, more importantly, the stage of hepatic fibrosis and whether the level of hepatic fibrosis has increased over time. Such concern is based on the fact that NAFLD patients with advanced fibrosis are at the greatest risk of developing complications of end-stage liver disease over time (Chalasani et al. 2012; Lonardo et al. 2015; EASL-EASD-EASO clinical practice guidelines 2016).

Although noninvasive methods for estimating hepatic fibrosis require further validation, they could be useful for selecting those patients with NAFLD who require a liver biopsy. The sensitivity and specificity of some noninvasive biomarkers for the assessment of hepatic fibrosis have recently been described. The enhanced liver fibrosis (ELF) score uses an algorithm and measurements of tissue inhibitor of matrix metalloproteinase-1, hyaluronic acid, and the aminoterminal peptide of pro-collagen III. It has excellent performance for diagnosing severe fibrosis, good performance for moderate fibrosis, and fair performance for identifying people without fibrosis. The NAFLD fibrosis score has good performance for identifying people without fibrosis, but poorer performance for diagnosing advanced fibrosis. Thus, a combination of both tests might improve diagnostic performance for different stages of hepatic fibrosis in NAFLD, without having to resort to liver biopsy (Castera et al. 2013; Byrne and Targher 2015; EASL-EASD-EASO clinical practice guidelines 2016). However, whether the currently available fibrosis biomarkers are also useful for monitoring NAFLD progression (or regression) in patients with established diabetes is uncertain (Bazick et al. 2015). Future studies combining the clinical prediction rules with other noninvasive imaging methods need to be performed to further improve the diagnostic accuracy.

Hepatic fibrosis can be also staged using vibration-controlled transient elastography (FibroScan<sup>®</sup>), which measures the velocity of a low-frequency elastic shear wave propagating through the liver. This velocity is directly related to tissue stiffness. The stiffer the tissue, the faster the shear wave propagates. The results are expressed in kPa and correspond to the median value of 10 validated measurements, ranging between 2.5 and 75 kPa, with normal (healthy liver) values of ~5.5 kPa. Advantages of transient elastography include a short procedure time (<5 min), immediate results, and the ability to perform the test at the bedside or in an outpatient clinic. However, accurate results require careful interpretation of data, based on at least 10 validated measurements to calculate a median value, a success rate (the ratio of valid measurements to the total number of measurements) >60%, and an interquartile range (IQR; reflects variations among measurements) of <30% of the median value (IQR/M <30%). The main limitation of ultrasonography-based transient elastography is its failure to obtain reliable liver stiffness measurements (~20% of cases, mainly in severely obese patients), which diminishes its application in NAFLD (Castera et al. 2013).

Several other liver-elasticity-based imaging techniques are being developed, including 2D acoustic radiation force impulse imaging (ARFI), shear-wave elastography, and 3D magnetic resonance elastography (Castera et al. 2013).

## Epidemiology and Natural History of NAFLD in Patients with Diabetes

Estimates of NAFLD prevalence may vary both by the population that is studied (e.g., studies in patients with different ethnicities, sex, and comorbidities) and the sensitivity of the modality used for diagnosis (serum liver enzymes, imaging techniques, or biopsy).

Hepatic fat content strongly correlates with the number of the metabolic syndrome features and the levels of serum aminotransferases. However, it is known that patients with T2DM have 80% more hepatic fat content and their serum liver enzymes levels are less representative of the severity of hepatic steatosis than age-, sex-, and body weight-matched nondiabetic controls. Moreover, patients with T2DM and NAFLD often have worse glycemic control than those without NAFLD, suggesting that NAFLD may hamper glycemic control in T2DM (Targher and Byrne 2013; Lonardo et al. 2015; EASL-EASD-EASO clinical practice guidelines 2016).

Based on these findings, it is not surprising that the prevalence of NAFLD is markedly increased in people with T2DM. As discussed in a recent review (Lonardo et al. 2015), the prevalence of NAFLD in patients with T2DM ranges from approximately 45% to 75% in large hospital-based studies and from approximately 30% to 70% in population-based studies. These wide interstudy variations might reflect differences both in the demographic features of patient cohorts and in the modality used to diagnose NAFLD. For instance, in the Valpolicella Heart Diabetes Study, involving 2839 Italian outpatients with T2DM (mean age 63 years, mean body mass index 27 kg/m<sup>2</sup>), the prevalence of NAFLD on ultrasonography was 69.5% (Targher et al. 2007a).

Strong evidence indicates that patients with T2DM are at high risk of developing NASH and a twofold to fourfold higher risk of developing serious liver-related complications (Chalasani et al. 2012; Anstee et al. 2013; Targher and Byrne 2013). For instance, the prevalence of advanced hepatic fibrosis, detected by noninvasive methods, in patients with T2DM has been estimated to be approximately between 3% and 7%. Some recent studies in patients with T2DM using magnetic resonance imaging to assess the liver proton density fat fraction and magnetic resonance elastography to estimate hepatic stiffness demonstrated high rates of both NAFLD (steatosis) and advanced fibrosis; approximately 65% and 7%, respectively (Doycheva et al. 2016). Early studies using liver biopsy observed that patients with T2DM have more severe NAFLD based on histology; with NASH rates up to 70% and advanced fibrosis in approximately 30–40% of patients (Castera et al. 2013; Byrne and Targher 2015; Lonardo et al. 2015). In a large prospective cohort study of approximately 1250 patients with biopsy-proven NAFLD, recently conducted by the National Institute of Diabetes and Digestive and Kidney Diseases (NIDDK)-sponsored NASH Clinical Research Network, the prevalence of NASH and advanced fibrosis on liver histology in the subgroup of patients with T2DM (mean age and BMI of these patients: 52.5 years and 35.8 kg/m<sup>2</sup>, respectively) was 69.2% and 41%, respectively (Bazick et al. 2015). The prevalence of histologically

proven NASH was also found to be high (56%) in a smaller study enrolling 103 obese T2DM patients with normal serum aminotransferase levels (Portillo-Sanchez et al. 2015). In addition, a recent study using a large administrative health database, involving almost 2.5 million people, has demonstrated that Canadian adults with newly diagnosed T2DM had an approximately twofold higher risk of developing serious liver disease (namely cirrhosis, liver failure, or liver transplantation) than matched individuals without diabetes over a follow-up period of 12 years (Porepa et al. 2010).

In addition to the presence of T2DM, other established clinical risk factors for NAFLD progression are older age (>45 years), obesity (body mass index >30 kg/m<sup>2</sup>), insulin resistance, aspartate aminotransferase-to-alanine aminotransferase (AST/ALT) ratio >1, increased ferritin levels, and hypertension (Chalasanani et al. 2012; Lonardo et al. 2015; EASL-EASD-EASO clinical practice guidelines 2016).

All these findings, together with the notion that patients with T2DM have an increased mortality risk from cirrhosis of any etiology, fully support screening for NAFLD and/or advanced fibrosis in people with T2DM.

Notably, it is important to note that most patients with T2DM and NAFLD (approximately 80%) have fairly normal serum liver enzyme levels, but this is not reassuring given that NASH, advanced fibrosis, and even cirrhosis may be found in patients with fairly normal serum liver enzymes. Therefore, normal serum liver enzyme levels should not preclude pursuing a histological diagnosis in high-risk groups of patients, especially if the presence of advanced liver disease is clinically suspected on the basis of transient elastography and/or noninvasive fibrosis biomarkers (Chalasanani et al. 2012; Anstee et al. 2013; Targher and Byrne 2013; Portillo-Sanchez et al. 2015; EASL-EASD-EASO clinical practice guidelines 2016).

At present, there are very few data regarding the prevalence and natural history of NAFLD in adults with type 1 diabetes (T1DM). However, the epidemiological impact of both NAFLD and the metabolic syndrome seems to be greatly relevant also in T1DM adults, since the prevalence of the metabolic syndrome is steadily growing in these patients, being nowadays approximately 40%. Some recent studies have reported that NAFLD as detected by ultrasonography is present in approximately 30–50% of adult patients with T1DM (Targher et al. 2010a, b). In a longitudinal cohort of T1DM and T2DM patients who underwent a liver biopsy, it was also demonstrated that adult patients with T1DM had a high risk of developing severe liver complications (e.g., cirrhosis and portal hypertension) comparable with that observed in patients with T2DM, who were matched for duration of diabetes, obesity, and other comorbidities (Harman et al. 2014).

---

## Association Between NAFLD and Poor Glycemic Control

In patients with T2DM, the presence of NAFLD often makes it difficult to obtain a good glycemic control. In clinical practice, it is well established that patients with coexistent T2DM and NAFLD have a poorer quality of glycemic control and require a higher amount of insulin to get a good glycemic control than their counterparts

without NAFLD (Anstee et al. 2013; Targher and Byrne 2013). It is believed that the intrahepatic fat content is the major determinant in explaining the daily amount of insulin needed to achieve good glycemic control in T2DM patients with NAFLD. In fact, in insulin-treated T2DM patients with stable glycemic control, intrahepatic fat content (as measured by proton magnetic resonance spectroscopy) is more closely correlated with the daily insulin dose and the ability of insulin to suppress hepatic glucose production, which better correlates the interindividual variation in insulin requirements. Moreover, some studies have observed a significant association between poor glycemic control and increased intrahepatic fat content in patients with T2DM, irrespective of age, sex, duration of diabetes, and body mass index. In patients with T2DM, the coexistence of NAFLD is associated with more severe hyperinsulinemia and greater insulin resistance in the skeletal muscle, adipose tissue, and liver compared with their counterparts without NAFLD (Portillo-Sanchez et al. 2015). Additionally, when the relationship between NAFLD and peripheral glucose metabolism is explored in healthy individuals, the association between intrahepatic fat content and peripheral insulin sensitivity is stronger than the association with intramyocellular lipid content, visceral fat content, or subcutaneous fat content (Anstee et al. 2013; Targher and Byrne 2013). To date, clear evidence indicates that NAFLD can interact with the regulation of multiple metabolic and inflammatory pathways and is involved in the development of incident T2DM, possibly via its direct contribution to hepatic glucose production, hepatic/peripheral insulin resistance, and the systemic release of multiple hepatokines (e.g., fetuin A, fetuin B, retinol-binding protein 4, and selenoprotein P) that adversely affect glucose metabolism and insulin action (Anstee et al. 2013; Targher et al. 2016a).

Collectively, therefore, these data suggest that increased intrahepatic fat infiltration is an important determinant of insulin resistance in the liver and affects the daily dosage of glucose-lowering therapy and achieving good glycemic control in patients with T2DM. These considerations also suggest that treatment strategies that decrease intrahepatic fat infiltration and improve insulin sensitivity might partly contribute to improved glycemic control in diabetic patients with NAFLD (Anstee et al. 2013; Byrne and Targher 2015).

---

## **Association Between NAFLD and Risk of Liver-Related Mortality and Morbidity**

It is established that patients with NAFLD have a substantially increased risk of all-cause mortality, with a higher risk of mortality from CVD, malignancy, and liver-related diseases (Chalasani et al. 2012; Anstee et al. 2013; Rinella 2015; EASL-EASD-EASO clinical practice guidelines 2016). Particularly, the histological subgroup analysis indicates that simple steatosis is a fairly benign condition, whereas NASH with varying degrees of hepatic fibrosis is more strongly associated with excess liver-related morbidity and mortality (Chalasani et al. 2012; Anstee et al. 2013; Rinella 2015). This relationship is well demonstrated in a recent

multinational retrospective study of 619 patients with biopsy-proven NAFLD from 1975 through 2005 at medical centers in the United States, Europe, and Thailand (Angulo et al. 2015). Over a median follow-up period of 12.6 years, 193 (33.2%) of these patients died or underwent liver transplantation. In this study, patients with advanced hepatic fibrosis had shorter survival rates than patients without fibrosis. Moreover, the hepatic fibrosis stage, with no other histologic features of NASH, was strongly associated with the risk of all-cause mortality, liver transplantation, and liver-related events (Angulo et al. 2015).

As previously discussed, several studies indicate that T2DM, abdominal obesity, and insulin resistance are among the strongest risk factors for the progression of NAFLD to NASH, advanced fibrosis, and cirrhosis. On the other hand, it is well known that the coexistence of chronic liver disease may also adversely influence the prognosis of diabetes. For example, in the Verona Diabetes Study, the risk of mortality from liver causes (mainly due to cirrhosis) was higher in the cohort of 7148 outpatients with T2DM than that observed in the age- and sex-matched general population (de Marco et al. 1999). Notably, the 5-year risk of mortality from liver causes was even higher than risk of mortality from cardiovascular causes. In fact, the standardized mortality rate in patients with T2DM was approximately 2.5 for liver causes and 1.3 for cardiovascular diseases (de Marco et al. 1999). These results were also confirmed in other large case-control studies. In all these studies, however, it was not possible to differentiate the various etiologies of chronic liver disease. Using a large electronic administrative database, Zoppini et al. recently analyzed all information available in death certificates in an entire region in northern Italy to investigate the etiology of chronic liver disease-associated mortality in people with diabetes ( $n = 167,621$  diabetic individuals aged 30–89 years of the Veneto region) (Zoppini et al. 2014). Notably, these investigators found that diabetic individuals had an approximately threefold higher risk of dying of chronic liver diseases, associated with a nonvirus and nonalcohol-related etiology, which is largely attributable to NAFLD (Zoppini et al. 2014). In agreement, a smaller community-based cohort study of 337 residents of Olmsted County (Minnesota) with diabetes mellitus reported that NAFLD (diagnosed by imaging or biopsy) had an approximately twofold increased risk of all-cause mortality (mainly due to CVD, malignancy, and liver-related complications) during a mean 11-year follow-up period (Adams et al. 2010). From all these studies, it is reasonable to assume that an early diagnosis and treatment of NAFLD, if any, may have a beneficial impact on survival rates of diabetic patients.

In the past decade, a marked increase in the incidence of hepatocellular carcinoma (HCC) has been observed internationally. Worldwide, most cases of HCC are related to chronic infection with viral hepatitis; however, over half of all cases of HCC in developed countries occur in patients who are not infected with viral hepatitis (Anstee et al. 2013; Reeves et al. 2016). Recent prospective studies have documented that there is a strong link among T2DM, NAFLD/NASH, and risk of HCC. It is known that the prevalence of HCC in patients with NAFLD is approximately 0.5% and increases to 3% in patients with NASH (Anstee et al. 2013; Michelotti et al. 2013). Studies also suggested that the prevalence of HCC is higher



in patients with T2DM and NAFLD. In fact, the coexistence of T2DM increases the risk of developing HCC (from 1.5- to 4.3-fold) (Anstee et al. 2013; Michelotti et al. 2013; EASL-EASD-EASO clinical practice guidelines 2016). A US-based population study reported in 2010 that NAFLD was the most common etiological factor in patients with HCC, as it was present in 58% of the 4406 patients with HCC who were surveyed. T2DM was the second most common factor, present in 35.8% of these patients. Furthermore, NAFLD remained the most common etiological factor in the subset of patients who only had a single risk factor for HCC, suggesting that this association was not simply through potentiation of other liver diseases. In a meta-analysis, patients with T2DM had a 2.5-fold increased risk of HCC than nondiabetic individuals (Anstee et al. 2013; Michelotti et al. 2013; Reeves et al. 2016).

Some evidence also suggests that the risk of HCC is increased in patients with a longer duration of diabetes and in those treated with sulfonylurea or insulin (Singh et al. 2013). Conversely, treatment with metformin appears to be associated with a lower risk of developing HCC (Zhang et al. 2012; Singh et al. 2013). However, these findings need further confirmation in large randomized clinical trials. To date, although viral cirrhosis and alcohol abuse are still the most important causes of primary liver cancers, NAFLD is becoming an emerging cause and, of course, will have an important impact on the development of this type of cancer in the near future.

All these considerations suggest the need for close and intensive surveillance for advanced liver disease in diabetic patients with NAFLD.

---

## **Association Between NAFLD and Risk of Chronic Kidney Disease and Other Microvascular Diabetic Complications**

In patients with T2DM, the presence of NAFLD is associated with an increased risk of microvascular diabetic complications, including CKD, retinopathy, and distal symmetric polyneuropathy.

In a large cohort study involving 2103 outpatients with T2DM (Targher et al. 2008a), it has been reported that patients with ultrasound-diagnosed NAFLD had remarkably higher age- and sex-adjusted prevalence rates of both nonproliferative and proliferative/laser-treated retinopathy and CKD than patients without NAFLD (Fig. 1). In logistic regression analysis, NAFLD was associated with increased rates of CKD (adjusted odds ratio 1.87; 95% CI 1.3–4.1) and proliferative/laser-treated retinopathy (adjusted odds ratio 1.75; 95% CI 1.1–3.7), independent of age, sex, body mass index, waist circumference, diabetes duration, hemoglobin A1c, plasma lipids, hypertension, smoking, and medication use (Targher et al. 2008a). Other studies in which NAFLD was diagnosed by either ultrasonography or histology have clearly shown that the presence and severity of NAFLD was strongly associated with an increased prevalence of abnormal albuminuria or decreased kidney function in patients with T2DM or prediabetes (Targher et al. 2014a). Some studies also showed that ultrasound-diagnosed NAFLD was associated, independently of

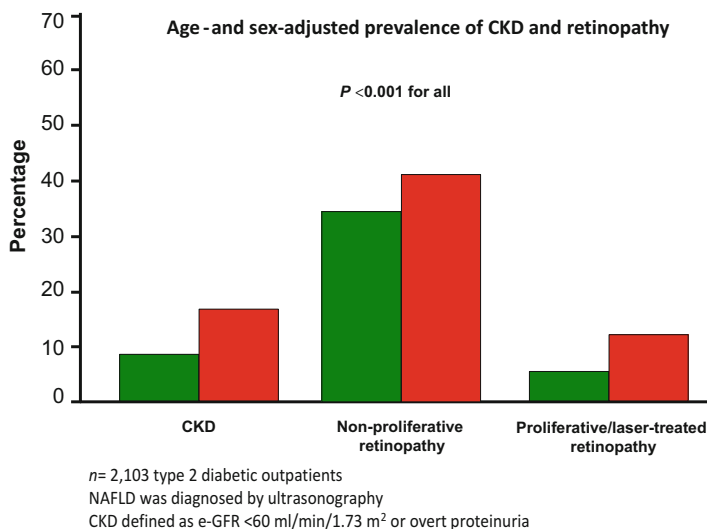

**Fig. 1** Age- and sex-adjusted prevalence of chronic kidney disease (defined as estimated GFR <60 mL/min/1.73 m<sup>2</sup> or overt proteinuria) and diabetic retinopathy in type 2 diabetic adults with (red columns) and without (green columns) ultrasound-diagnosed NAFLD. (Data derived from Targher et al. 2008a)

multiple confounding factors, with a higher prevalence of CKD and retinopathy in adult patients with T1DM (Targher et al. 2010b).

To date, there is a paucity of published data regarding the risk of developing incident CKD in diabetic patients with NAFLD. The Valpolicella Heart Diabetes Study enrolled 1760 T2DM patients with normal or near-normal kidney function who did not have CVD, cirrhosis, and viral hepatitis at baseline (Targher et al. 2008b). During a mean follow-up of 6.5 years, 547 participants developed incident CKD (defined as estimated glomerular filtration rate [e-GFR] <60 mL/min/1.73 m<sup>2</sup> or overt proteinuria). Cox regression analysis revealed that ultrasound-diagnosed NAFLD was associated with a nearly 70% increased risk of incident CKD (hazard ratio 1.69; 95% CI 1.3–2.6), independently of a broad number of coexisting cardio-renal risk factors (including also diabetes duration, hypertension, baseline e-GFR, albuminuria, and medication use) (Targher et al. 2008b).

In agreement, in a smaller follow-up study involving 261 T1DM adult patients with preserved kidney function and without overt proteinuria at baseline, who were followed for a mean period of 5.2 years, the presence of NAFLD on ultrasonography was associated with an increased incidence of CKD (hazard ratio 2.85, 95% CI 1.6–5.1). Adjustments for age, sex, duration of diabetes, hypertension, HbA1c, and baseline e-GFR did not appreciably attenuate this association. Results remained unchanged even after excluding those who had microalbuminuria at baseline (adjusted hazard ratio 1.85, 1.03–3.3). Notably, addition of NAFLD to traditional risk factors for CKD significantly improved the discriminatory capability of the regression models for predicting CKD (Targher et al. 2014b).

Finally, preliminary evidence also suggests that NAFLD is associated with an increased prevalence of distal symmetric polyneuropathy and cardiac autonomic dysfunction both in patients without diabetes and in those with T1DM or T2DM (Byrne and Targher 2015; Mantovani et al. 2016a). However, further studies are required to confirm this issue.

Despite the growing evidence that links NAFLD with CKD and other microvascular complications in patients with T1DM or T2DM, it remains to be established whether a causal association also exists. There is uncertainty as to whether NAFLD poses an independent risk for diabetic nephropathy and retinopathy above and beyond that conferred by known risk factors. There is a suggestion in that direction, but studies are too few and are not methodologically rigorous. Additional large-scale prospective studies are needed to draw a firm conclusion about any independent hepatic contribution to the increased risk of developing microvascular complications observed among diabetic patients with NAFLD. In the meantime, however, all these studies suggest that diabetic patients with NAFLD need more careful surveillance and treatment to reduce the risk of developing CKD and other microvascular complications of diabetes.

---

### **Association Between NAFLD and Risk of Cardiovascular, Cardiac, and Arrhythmic Complications**

Over the last 10 years, growing epidemiological evidence has strongly documented that NAFLD, diagnosed either by imaging or by histology, is not only associated with an increased risk of liver-related morbidity and mortality but is also associated with an increased risk of developing CVD death and events both in patients without diabetes and in those with T1DM or T2DM. Indeed, clear evidence indicates that CVD is the leading cause of mortality among patients with NAFLD (Targher et al. 2010c; Byrne and Targher 2015; Rinella 2015; EASL-EASD-EASO clinical practice guidelines 2016).

Several cross-sectional studies have consistently shown that NAFLD is associated with both various markers of subclinical atherosclerosis (including also increased coronary artery calcium score) and clinically manifest CVD across a wide range of patient populations, including patients with diabetes (Byrne and Targher 2015; Mantovani et al. 2016a). For example, the Valpolicella Diabetes Heart Study reported that patients with T2DM and NAFLD had a higher age- and sex-adjusted prevalence of clinically manifest coronary, cerebrovascular, and peripheral vascular disease compared to their counterparts without NAFLD (Fig. 2). In logistic regression analysis, NAFLD on ultrasonography was associated with an increased risk of prevalent CVD independent of traditional CVD risk factors, hemoglobin A1c, metabolic syndrome features, and use of medications (Targher et al. 2007a). Similar findings were also found in adult patients with T1DM (Targher et al. 2010a). Moreover, in patients referred for clinically indicated coronary angiography, the presence of NAFLD was associated with a greater severity of coronary artery disease and an increased prevalence of high-risk and vulnerable coronary

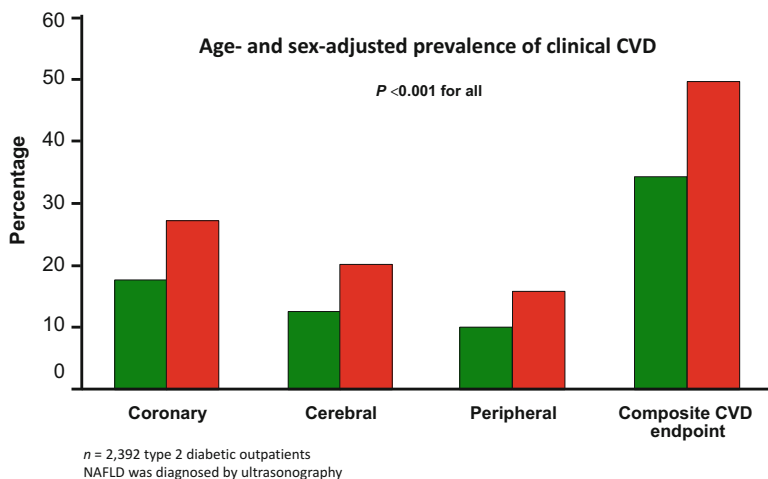

**Fig. 2** Age- and sex-adjusted prevalence of coronary (defined as myocardial infarction, angina, or revascularization procedures), cerebrovascular (ischemic stroke, recurrent transient ischemic attacks, carotid endarterectomy, or carotid stenosis  $>70\%$  as diagnosed by echo-Doppler scanning), and peripheral (intermittent claudication, rest pain, as confirmed by echo-Doppler scanning, lower extremity amputation, or revascularization procedures) in type 2 diabetic adults with (red columns) and without (green columns) ultrasound-diagnosed NAFLD. (Modified by Targher et al. 2007a)

artery plaques, independent of the extent and severity of coronary atherosclerosis (Byrne and Targher 2015; Mantovani et al. 2016a).

To date, convincing epidemiological evidence also substantiates the existence of a link of NAFLD with subclinical myocardial remodeling and dysfunction (i.e., left ventricular diastolic dysfunction and hypertrophy), valvular heart diseases (i.e., aortic-valve sclerosis and mitral annulus calcification), and increased risk of permanent atrial fibrillation both in patients without diabetes and in those with T2DM (Lonardo et al. 2016; Mantovani et al. 2016a). Preliminary evidence also supports a significant and independent association of NAFLD with heart rate-corrected QT interval prolongation on standard electrocardiograms in both nondiabetic and diabetic individuals, and an increased prevalence of ventricular tachyarrhythmias on 24-h Holter monitoring (i.e., presence of nonsustained ventricular tachycardia,  $>30$  premature ventricular complexes per hour, or both) in patients with T2DM (Lonardo et al. 2016; Mantovani et al. 2016a, b).

Although the cross-sectional associations of NAFLD with CVD and other cardiac and arrhythmic complications are strong and consistently demonstrated across different patient populations (including people with diabetes), the currently available data on whether NAFLD *per se* is simply a risk marker that coexists in people at increased risk of CVD or is an independent risk factor for CVD is debatable. Moreover, uncertainty also exists about the prognostic value of NAFLD in risk stratification for CVD (Targher et al. 2010c; Lonardo et al. 2016).

However, with those caveats, a growing body of evidence now suggests that CVD is a serious threat to patients with NAFLD and that CVD dictates the outcome(s) in

patients with NAFLD more frequently and to a greater extent than does the progression of liver disease (Targher et al. 2010c; Anstee et al. 2013; Byrne and Targher 2015; Rinella 2015; Lonardo et al. 2016; EASL-EASD-EASO clinical practice guidelines 2016).

In patients with NAFLD diagnosed by imaging techniques, several large hospital-based and population-based studies reported an increased incidence of fatal and nonfatal CVD events, independent of established CVD risk factors, both in patients with T2DM and in those without established T2DM (Targher et al. 2010c; Anstee et al. 2013; Byrne and Targher 2015; Lonardo et al. 2016; Mantovani et al. 2016a).

For instance, the Valpolicella Diabetes Heart Study, involving 2103 T2DM patients without prior CVD and secondary causes of chronic liver disease at baseline, reported that patients with ultrasound-diagnosed NAFLD had an approximately twofold increased risk of developing nonfatal ischemic heart disease (defined as myocardial infarction and coronary revascularization procedures), nonfatal ischemic stroke, or cardiovascular death (adjusted hazard ratio 1.87, 95% CI 1.2–2.6) compared with patients without NAFLD over a 6.5-year follow-up period. Notably, this relationship was independent of age, sex, body mass index, smoking, diabetes duration, hemoglobin A1c, low-density lipoprotein (LDL) cholesterol, metabolic syndrome features, and use of hypoglycemic, anti-hypertensive, lipid-lowering, and antiplatelet drugs (Targher et al. 2007b).

A recent systematic review and meta-analysis of 16 observational studies, involving approximately 34,000 individuals (36.3% of whom with NAFLD as detected by imaging or histology), confirmed that patients with NAFLD, irrespective of the presence of diabetes, had a higher risk of fatal and nonfatal CVD events than those without NAFLD (random-effects odds ratio 1.64, 95% CI 1.26–2.13). In addition, patients with more “severe” NAFLD (defined either by presence of hepatic steatosis on imaging *plus* either increased serum gamma-glutamyltransferase concentrations or high NAFLD fibrosis score or high  $^{18}\text{F}$ -fluoro-2-deoxyglucose uptake on positron emission tomography or by increasing fibrosis stage on liver biopsy) were also more likely to develop fatal and nonfatal CVD events (random-effects odds ratio 2.58; 95% CI 1.78–3.75) (Targher et al. 2016b).

Although the results of this large and updated meta-analysis provide robust evidence of the association between NAFLD and risk of developing major CVD events both in patients with and without T2DM, it is important to underline that the quality of published studies was not always high and that causality remains to be proven in high-quality intervention studies (Targher et al. 2016b). Moreover, the key question of whether the prognostic role of NAFLD in CVD development is restricted only to NASH (with varying amounts of liver fibrosis) or is also associated with simple steatosis remains still unresolved. More research is needed to address this issue.

Taken together, however, the current evidence from the published studies indicates that a diagnosis of NAFLD identifies a subset of individuals, which is exposed to a higher risk of CVD mortality and morbidity. This also implies that patients with NAFLD should undergo careful cardiovascular surveillance. In line with this implication, given that CVD complications frequently dictate the outcome(s)

of NAFLD, the EASL-EASD-EASO clinical practice guidelines have strongly recommended screening of cardiovascular system in all patients with NAFLD, at least by detailed risk factor assessment (EASL-EASD-EASO clinical practice guidelines 2016).

However, it is not yet established whether addition of NAFLD to the currently available risk assessment calculators significantly improves CVD risk prediction. Moreover, randomized controlled trials with major CVD outcomes that focus on treatments for liver disease in NAFLD are also needed to definitely establish a causal relationship between NAFLD and risk of developing CVD events.

---

### **Putative Mechanisms Linking NAFLD with Cardiovascular, Cardiac, and Kidney Complications**

It is beyond the scope of this chapter to discuss in detail the pathophysiological links between NAFLD and CVD/cardiac complications as well as the links between NAFLD and CKD. Detailed discussions of this topic have been published elsewhere (Targher et al. 2010c; Anstee et al. 2013; Mantovani et al. 2016a; Lonardo et al. 2016).

To date, a clear understanding of the pathophysiological pathways linking NAFLD to the development of CVD, cardiomyopathy, and CKD remains elusive, because of the intricate interactions among NAFLD, abdominal obesity, insulin resistance, chronic inflammation, and oxidative stress. NAFLD, cardiovascular/cardiac diseases, and CKD share many metabolic features and cardiovascular risk factors, leading to the concept that they belong to a complex multisystem disease with several organ manifestations and a complex interplay between the different diseases, with multiple bidirectional cause–effect relationships. The specific contribution of one disease to the others is therefore difficult to discern, and there might be substantial interindividual variability.

However, a growing body of evidence to date suggests that NAFLD is not simply a marker of both CVD and CKD but is also implicated in the pathogenesis of these important extrahepatic complications (Targher et al. 2010c; Anstee et al. 2013; Mantovani et al. 2016a; Lonardo et al. 2016).

Figure 3 schematically summarizes the putative mechanisms linking NAFLD, expanded and inflamed adipose tissue, and altered gut microbiota with CKD and CVD complications in people with diabetes.

Both expanded/inflamed (“dysfunctional”) visceral adipose tissue and altered intestinal microbiota (intestinal dysbiosis) may influence the development and progression of NAFLD, through the production and release of nonesterified fatty acids, proinflammatory adipocytokines (e.g., tumor necrosis factor- $\alpha$  and interleukin-6), short-chain fatty acids (SCFAs) (e.g., butyrate, propionate and acetate), incretins (e.g., glucagon-like peptide 1), and thrombospondin-1 and decreased production of adiponectin levels. When NAFLD develops and when hepatic fat, inflammation, and fibrosis progress (NASH), many important alterations occur in the liver, resulting in the worsening of hepatic/systemic insulin resistance, the production

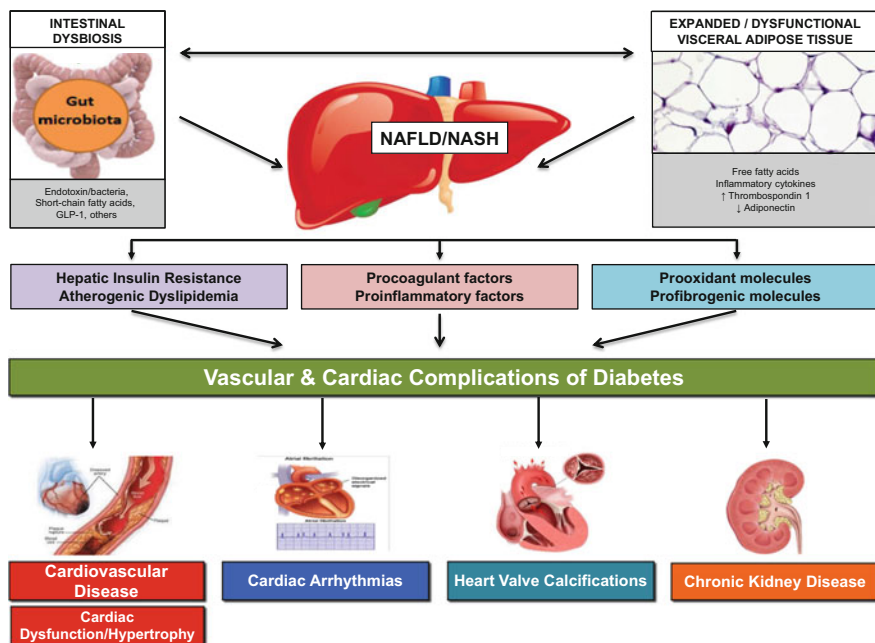

**Fig. 3** Schematic representation of putative mechanisms by which NAFLD may contribute to the development and progression of chronic vascular complications of diabetes

of atherogenic lipids, and the systemic release of a myriad of proinflammatory, prooxidant, prothrombotic, and vasoactive mediators. All these NAFLD-related changes can adversely influence the risk of developing CKD, CVD, and other cardiac complications (Targher et al. 2010c; Anstee et al. 2013; Byrne and Targher 2015; Mantovani et al. 2016a; Lonardo et al. 2016).

However, although all these pathophysiological mechanisms plausibly link NAFLD to the development and progression of both CVD and CKD, no studies to date have definitely proven a cause-and-effect relationship, and further research is needed to gain mechanistic insights into the pathophysiology linking NAFLD to CVD and CKD. An improved knowledge of the pathophysiological links between NAFLD, diabetes, and these chronic vascular complications will not only help develop new pharmacological treatments for NAFLD but may also help decrease the global burden of these very common noncommunicable diseases that share a “common soil” with NAFLD.

### Management of NAFLD in Patients with Diabetes

Existing diabetes guidelines do not advocate screening for liver-related complications among patients with T2DM or T1DM, making the liver a potentially neglected target organ for undetected chronic disease progression to cirrhosis. However, given

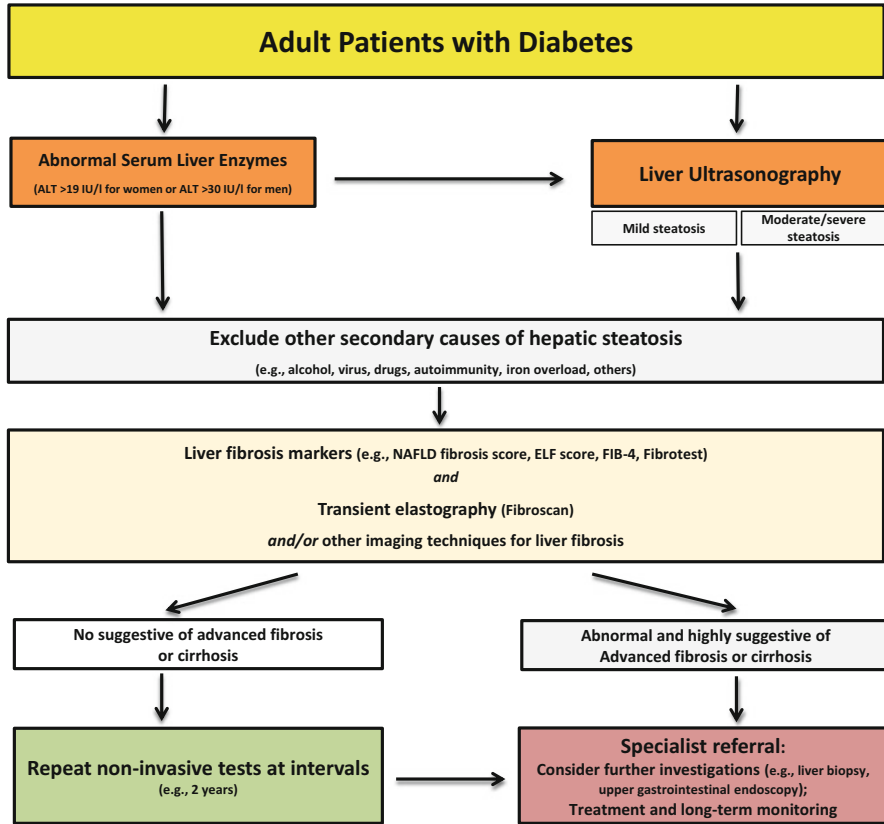

**Fig. 4** Proposed pragmatic algorithm for the diagnosis and management of NAFLD in adult patients with diabetes. The algorithm has been developed by the authors using both available evidence and guidelines, as well as personal opinion where uncertainty exists and evidence is not available

the increasingly growing prevalence of NAFLD in people with diabetes and its related hepatic and extrahepatic complications, NAFLD should always be ruled out in all adult individuals with T2DM or T1DM.

Figure 4 shows a possible pragmatic algorithm for the diagnosis and management of NAFLD in people with diabetes. It is important to emphasize that currently, in the literature, there is an intense debate on these aspects and that a completely validated and shared algorithm for the diagnosis and management of NAFLD in adult patients with T1DM or T2DM does not exist yet. Therefore, this proposed algorithm is based on available evidence and guidelines as well as authors' personal opinions, when uncertainty exists and evidence is unavailable.

To date, whether individuals with T2DM and NAFLD should be treated to a specific HbA1c, LDL-cholesterol, and blood pressure target remains uncertain. NAFLD is a novel and emerging CVD risk factor that often coexists



with features of the metabolic syndrome. Since CVD risk tends to be underestimated in patients with T2DM, it is likely that the available (traditional) CVD risk algorithms will further underestimate the CVD risk in people with coexistent T2DM and NAFLD. Consequently, in the absence of available evidence to the contrary, the authors recommend treatment with a statin in all patients with NAFLD if estimated 10-year CVD risk score is  $>15\%$  using any of the available CVD risk calculators. Whether clinicians should treat plasma LDL cholesterol to target is also currently unknown. A pragmatic approach would be to assume that patients are at the same CVD risk as individuals who have already suffered a first atherosclerotic CVD event and adjust their statin dose accordingly, aiming to treat to a target LDL cholesterol of  $<2.6$  mmol/L (a lower LDL cholesterol goal of  $<1.8$  mmol/L is suggested in individuals with overt CVD) (Targher and Byrne 2013). Patients with high triglyceride and/or low HDL cholesterol levels should be also treated with fenofibrate (or high-dose omega 3 polyunsaturated fatty acids).

As previously reported, serum liver enzymes (i.e., serum aminotransferases and gamma-glutamyltransferase levels) are not reliable indicators for the screening and diagnosis of NAFLD in patients with T2DM or T1DM and, therefore, they should not be used alone in clinical practice. As previously discussed, the majority of diabetic patients with NAFLD have normal or only slightly elevated levels of serum liver enzymes (Chalasani et al. 2012; Targher and Byrne 2013). Moreover, patients with normal versus elevated serum aminotransferase levels may have similar severity of NASH or liver fibrosis. For these reasons, many authors have proposed to reduce the normal range values of serum aminotransferases (suggesting, serum alanine aminotransferase [ALT]  $<19$  U/L for women and  $<30$  U/L for men, respectively) in order to increase the likelihood of excluding NAFLD (Chalasani et al. 2012; EASL-EASD-EASO clinical practice guidelines 2016).

As previously discussed, it is known that liver ultrasonography has a good diagnostic accuracy to detect the presence of mild and moderate-severe steatosis, demonstrating a sensitivity and specificity, respectively, of 85% and 95% (especially when liver fat infiltration is at least 20–30%). Moreover, ultrasonography is relatively inexpensive and may help clinicians to exclude other causes of liver diseases and identify any early signs of cirrhosis or portal hypertension. Therefore, as suggested by several authors, this imaging technique is now the recommended first-line imaging modality for the screening and diagnosis of NAFLD in patients with and without diabetes mellitus (Chalasani et al. 2012; Targher and Byrne 2013; EASL-EASD-EASO clinical practice guidelines 2016).

As shown in Fig. 4, the proposed algorithm can be used to identify T2DM/T1DM patients for liver biopsy, or if biopsy is not undertaken (as is occurring more frequently in many centers), a careful assessment of liver fibrosis by the use of noninvasive markers of fibrosis and/or transient elastography (FibroScan) is mandatory for selecting patients for upper gastrointestinal endoscopy, potential treatment of esophageal varices, and routine surveillance. The NAFLD fibrosis score and fibrosis-4 (FIB4) score are examples of validated nonproprietary, noninvasive clinical scores for estimating the severity of liver fibrosis. The enhanced liver fibrosis (ELF) score

and the Fibrotest are examples of proprietary clinical scores that have also been proposed for the noninvasive assessment of advanced hepatic fibrosis based on clinical biochemical indices and/or panels of specific serum fibrosis biomarkers.

In a cohort study of over 1900 Chinese patients with T2DM, it has been tested the strategy of screening diabetic patients for NAFLD with FibroScan (Kwok et al. 2016). Hepatic steatosis and fibrosis were assessed by controlled attenuation parameter (CAP) and liver stiffness measurements by FibroScan at a diabetic center for patients from primary care and hospital clinics. The authors found that diabetic patients had a very high prevalence of hepatic steatosis (72.8%, 95% CI 70.7–74.8%) and advanced hepatic fibrosis (17.7%, 95% CI 16.0–19.5%). Those with obesity and dyslipidemia were at particularly high risk and may be the target for liver assessment (Kwok et al. 2016). These data further support screening for NAFLD and/or advanced fibrosis in patients with T2DM.

---

## Treatment Options for NAFLD in Patients with Diabetes

Currently, there are no approved pharmacological agents for the treatment of NAFLD. Most interventions evaluated for NAFLD treatment are those commonly used for the treatment of T2DM and exert a rather indirect effect through improvement in both insulin resistance and plasma glucose levels. These pharmacological interventions have also been to date the most effective treatments for NAFLD, which is perhaps not surprising, considering the high degree of interplay between these two diseases. Currently, however, no specific data are available regarding the pharmacological agents for the treatment of NAFLD in adult patients with T1DM.

Pharmacotherapy for NAFLD should probably be reserved for patients with NASH, who are at the highest risk for disease progression (Chalasani et al. 2012; EASL-EASD-EASO clinical practice guidelines 2016). However, the major problem in this field of research is the scarcity of definitive, large randomized controlled trials. To date, there are very few high-quality, randomized, blinded, adequately powered, controlled trials of sufficient duration and with adequate histological outcomes.

Currently, the therapeutic approach to diabetic patients with NAFLD is multifactorial, as summarized in Fig. 5. The first approach is the treatment of overweight and obesity (especially through appropriate changes in lifestyles and/or bariatric surgery for properly selected patients with severe obesity), the optimization of glycemic control, and the treatment of all coexisting cardiometabolic risk factors, mainly atherogenic dyslipidemia and hypertension, possibly by the use of drugs with potentially positive hepatic effects. The main goals of treatment are to improve insulin resistance, to reduce intrahepatic fat infiltration, and to avoid the progression of NAFLD/NASH to more severe histological forms (cirrhosis, liver failure, and HCC) (Table 1).

All patients with NAFLD, irrespective of presence of diabetes, should avoid alcohol consumption, even moderate, as well as the use of potentially hepatotoxic drugs, when possible. Similar recommendations should be given for the use

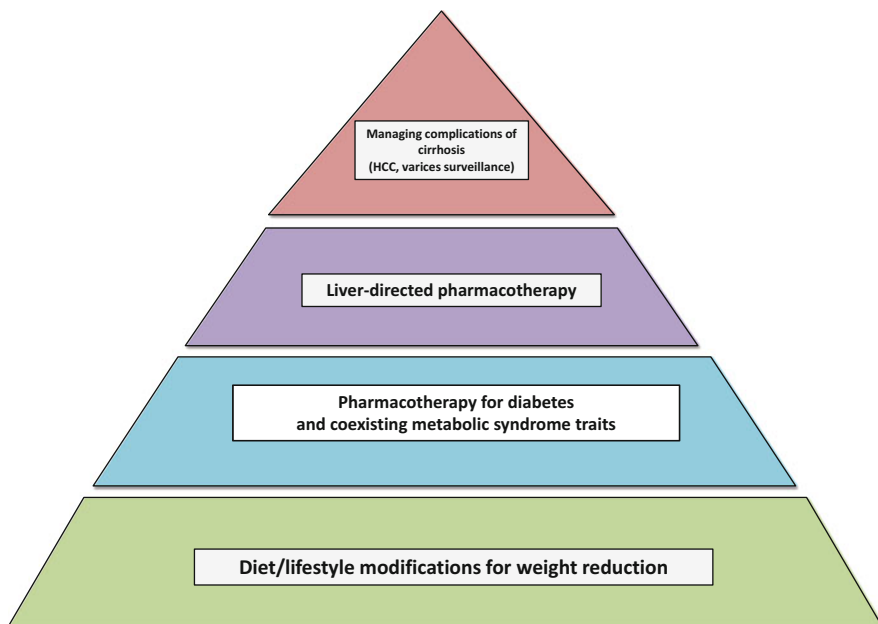

**Fig. 5** Management strategies of NAFLD in patients with diabetes

**Table 1** Management strategies of NAFLD/NASH in patients with type 2 diabetes

Treatment of NAFLD in patients with T2DM
Weight loss through appropriate diet/lifestyle modifications (need a reduction of 5% to ameliorate hepatic steatosis and about 10% to improve liver necro-inflammation)
Stop cigarette smoking and avoid excessive alcohol consumption
Regular exercise/physical activity: 150 min/week of moderate-intensity aerobic physical activities in 3–5 sessions are generally recommended. Alternatively, resistance training is effective, having effects on metabolic risk factors
Avoid fructose-containing beverages and foods
Achieve a good glycemic control (hemoglobin A1c <7% [ $<53$ mmol/mol] if no contraindications); metformin is the first drug of choice for most patients with T2DM. If the patient has biopsy-proven NASH and there are no contraindications, consider pioglitazone. Consider also GLP-1 agonists if no contraindications
If blood pressure is $\geq 140/90$ mmHg, start an appropriate anti-hypertensive therapy; treatment with ACE-inhibitors or angiotensin receptor blockers as first-line therapy
If dyslipidemia or 10-year cardiovascular risk $>15\%$ , start treatment with statins ( <i>plus</i> fenofibrate if necessary)
If body mass index $>35$ kg/m <sup>2</sup> , consider bariatric (metabolic) surgery
Monitoring for onset hepatic complications (e.g., cirrhosis, portal hypertension, esophageal varices, and hepatocellular carcinoma)

Note: Currently, no specific indications for the treatment and management of NAFLD in adult patients with type 1 diabetes are available. However, a careful surveillance for advanced liver disease as well as an early, aggressive treatment of all modifiable cardiovascular risk factors are also needed in this group of patients

of cigarette smoking to avoid the worsening of the NAFLD-related CVD risk. Clinicians should also recommend avoiding fructose-containing beverages and foods, given that an association has been reported between high fructose intake and risk of progressive NAFLD (Chalasani et al. 2012; Rinella 2015; EASL-EASD-EASO clinical practice guidelines 2016).

It is well established that gradual body weight reduction, achieved either by hypocaloric diet alone or in combination with regular physical activity, can be effective in decreasing hepatic steatosis, necroinflammation, and fibrosis; the reduction of hepatic steatosis and necroinflammation is proportional to the intensity of the lifestyle intervention and generally requires a weight loss between 5% and 10% (a reduction of hepatic fibrosis is usually less easy to obtain, but it requires a sustained weight loss of at least 10%). However, in real life, an adequate weight loss is very difficult to achieve and maintain, and an appropriate aerobic physical activity is often impractical, especially in older T2DM patients, because of comorbid joint arthritis limiting a full range of joint movements. In such a situation, resistance training might be a valid alternative option to help induce a net negative energy balance and decrease hepatic fat content. Recent research has also shown a benefit of resistance training in ameliorating some of the histological features of NAFLD, independently of weight loss (Chalasani et al. 2012; Rinella 2015; EASL-EASD-EASO clinical practice guidelines 2016).

Many people with T2DM are treated with statins for dyslipidemia. It should be noted that statins can be safely used for dyslipidemia in patients with NAFLD/NASH, and some studies, although not all, have also suggested that statins might exert some beneficial effect on NASH histology. To date, however, as randomized controlled trials with histological liver endpoints are not available, statins should not be used to specifically treat NAFLD/NASH (Chalasani et al. 2012; Targher and Byrne 2013; Corey and Rinella 2016; EASL-EASD-EASO clinical practice guidelines 2016).

To date, only limited evidence supports definitive treatment recommendations for specific pharmaceutical therapy in patients with coexistent NAFLD/NASH and diabetes. The available randomized controlled trials studying the histological liver endpoints in this patient population are generally small, with a short duration, and have provided inconsistent outcomes. Thus, tailoring an individual treatment strategy to reduce body weight and optimize metabolic control of diabetes with the potential to improve liver phenotype remains the current gold standard.

The most available evidence for the treatment of NAFLD is the use of pioglitazone in patients with biopsy-proven NASH (Chalasani et al. 2012; Rinella 2015; EASL-EASD-EASO clinical practice guidelines 2016; Ratziu 2016). The effect of pioglitazone (an insulin-sensitizing agent that is a selective ligand of the peroxisome-proliferator-activated receptor gamma) is partly mediated by increases in adiponectin, which is known to exert beneficial effects on the liver that include reducing hepatic gluconeogenesis and reducing fatty acid influx. Some randomized controlled trials have documented that pioglitazone treatment significantly improves hepatic steatosis and necroinflammation, but not hepatic fibrosis, in patients with biopsy-proven NASH and that its interruption may determine the reappearance of

liver damage. To note, the majority of participants of these published clinical trials were nondiabetic. More recently, in a randomized, double-blind, placebo-controlled trial (including 101 patients with prediabetes or T2DM and biopsy-proven NASH who were randomly treated with pioglitazone, 45 mg/day, or placebo for 18 months, and then followed by an 18-month open-label phase with pioglitazone treatment), Cusi et al. have reported that among those randomly assigned to pioglitazone, 58% achieved the primary study outcome (i.e., a reduction of at least 2 points in the NAFLD activity score in 2 histologic categories without worsening of fibrosis) and 51% had resolution of NASH. Pioglitazone treatment was also associated with reduced intrahepatic fat content and improved adipose tissue, hepatic, and muscle insulin sensitivity. All 18-month metabolic and histologic improvements persisted over 36 months of therapy. The overall rate of adverse events did not significantly differ between the two groups, although weight gain was greater with pioglitazone (~2.5 kg vs. placebo) (Cusi et al. 2016). Despite these encouraging data, pioglitazone is currently not licensed for the treatment of NAFLD/NASH, and some concerns regarding fluid retention, weight gain, and, to a lesser extent, increased risk of bone fractures and bladder cancer have meant that the chronic use of pioglitazone in T2DM patients with NAFLD remains limited.

Metformin is currently the first-line therapeutic agent in the management of patients with T2DM. Studies using metformin for the treatment of NAFLD have produced conflicting results. Collectively, these studies suggested that metformin treatment has beneficial effects on serum liver enzymes and insulin resistance but has no significant effect on NAFLD histology. However, some experimental and observational (case-control or prospective) studies have suggested that treatment with metformin in patients with T2DM may reduce the risk of developing HCC, a serious complication of NAFLD (Zhang et al. 2012; Singh et al. 2013; Chen et al. 2013). In vitro studies showed that metformin is an activator of AMP-activated protein kinase signaling and reduces mTOR pathway (Chen et al. 2013). Further investigation is warranted on this issue. That said, metformin is not currently recommended as a specific treatment for liver disease in patients with NAFLD/NASH (Chalasanani et al. 2012; Rinella 2015; EASL-EASD-EASO clinical practice guidelines 2016).

Sulfonylureas are commonly used as second-line agents for glycemic control in patients with T2DM. There are no currently prospective data examining their use in NAFLD with coexistent diabetes. Some retrospective data exist suggesting that the prevalence of hepatic fibrosis in patients with T2DM and NAFLD is slightly higher in those treated with sulfonylureas. However, no adjustment was made for glycemic control or diabetes duration. Given the availability of generic sulfonylureas, it is unlikely that future prospective studies will address the outstanding issues that surround their use in the context of NAFLD; however, as this class of drugs is associated with a gain in weight and is metabolized extensively by the liver, it is unlikely to be an attractive treatment option for T2DM patients with coexistent NAFLD.

The incretin mimetic drugs (i.e., dipeptidyl peptidase [DPP]-4 inhibitors and glucagon-like peptide [GLP]-1 agonists) are now widely prescribed as adjunctive

oral therapy in patients with T2DM. This class of drugs is effective for the treatment of T2DM, determining weight loss, reducing appetite, and improving insulin sensitivity. GLP-1 receptors are present in human hepatocytes, and activation of these receptors may have a direct action to decrease hepatic steatosis by improving insulin signaling. Experimental data in animals support the use of GLP-1 agonists for NAFLD treatment. Human studies investigating the effect of some GLP-1 agonists (exenatide and liraglutide) on liver injury are currently limited to single case reports and large retrospective studies of serum liver enzymes in patients with T2DM. These two drugs significantly improved serum liver enzyme concentrations in a dose-dependent manner, with comparable safety profiles in T2DM patients with and without abnormal liver biochemistry (Targher and Byrne 2013; Rinella 2015; Corey and Rinella 2016; EASL-EASD-EASO clinical practice guidelines 2016). More recently, a double-blind, randomized, placebo-controlled phase 2 study (LEAN) trial (involving 52 obese patients with and without T2DM with biopsy-proven NASH) employing liraglutide 1.8 mg per day subcutaneously resulted in significant decreases in liver fat content and histological resolution of NASH in more patients compared with placebo (39% vs. 9%) after 48 weeks of treatment (Armstrong et al. 2016). This may suggest that liraglutide exerts effects additional to simple weight loss. Future, longer-term phase 3 trials with liraglutide are needed to confirm its efficacy in patients with NASH. Thus, at present, although GLP-1 agonists have shown promising results in the improvement of hepatic steatosis and necroinflammation, there are no robust data with histological endpoints as a primary outcome to formally comment on the effectiveness of GLP-1 agonists as a treatment for NAFLD/NASH with coexistent diabetes. Currently, no evidence is available regarding the efficacy of DDP-4 inhibitors for the treatment of NAFLD/NASH in diabetes. Prescribing advice remains to use caution in more severe hepatic impairment, although this class of agents is predominantly renally excreted.

Sodium glucose cotransporter 2 (SGLT2) inhibitors are a new class of oral hypoglycemic agents that work by decreasing renal glucose reabsorption. Some animal models of NAFLD with SGLT2 inhibitors have demonstrated a protective effect on hepatic steatosis, inflammation, and fibrosis. This attenuated steatosis–fibrosis progression may well be due to a combination of negative energy balance through glycosuria and substrate switching toward lipids as a source of energy expenditure. To date, there are no human studies of SGLT2 inhibitors and NAFLD; however, given the net weight loss of approximately 1.8 kg seen in a published meta-analysis, it may represent an attractive pharmacological strategy, but this remains to be investigated in dedicated randomized controlled trials.

It is known that chronic insulin treatment increases body fat, but it does not appear to promote or worsen NAFLD in patients with diabetes (EASL-EASD-EASO clinical practice guidelines 2016). While acute insulin infusion dose-dependently increases hepatic fat content in T2DM, chronic insulin treatment improves adipose tissue insulin resistance and therefore reduces free fatty acid flux and hepatic fat content. A pilot randomized clinical trial comparing the 12-week effects of insulin glargine and liraglutide therapy on liver fat content as measured by magnetic resonance in 35 patients with T2DM inadequately controlled with oral agents

therapy found that the administration of insulin glargine therapy significantly reduced the liver fat burden in these patients (Tang et al. 2015).

High doses of omega-3 polyunsaturated fatty acids (PUFAs) are effective in treatment of hypertriglyceridemia that is often observed in patients with T2DM and NAFLD. Nine eligible studies, involving about 350 patients with NAFLD and testing doses of omega-3 PUFA treatments, have documented significant reductions in hepatic fat content without relevant side effects. However, the size of the effect was relatively small. To date, the optimal dose and duration of treatment with omega-3 PUFAs are not known, and well-designed randomized controlled trials are needed to recommend omega-3 PUFA supplementation for the treatment of NAFLD/NASH (Chalasani et al. 2012; Targher and Byrne 2013; EASL-EASD-EASO clinical practice guidelines 2016).

Given that increased oxidative stress occurs in both NAFLD and T2DM, another therapeutic option for NAFLD treatment is to decrease oxidative stress by administration of an antioxidant, such as vitamin E. In the PIVENS trial, involving 247 nondiabetic adults with NASH, the treatment with vitamin E (at a dose of 800 U/day for 96 weeks), as compared with placebo, was associated with significant improvements in serum liver enzymes and some histological features of NASH (steatosis, inflammation, and ballooning). However, before vitamin E can be recommended for the treatment of NAFLD, further evidence is required to support efficacy and, importantly, the safety of this fat-soluble agent. Moreover, insufficient evidence is available to treat patients with diabetes or cirrhosis (Chalasani et al. 2012; Rinella 2015; Corey and Rinella 2016; EASL-EASD-EASO clinical practice guidelines 2016).

Pentoxifylline has been shown to decrease oxidative stress and inhibit lipid oxidation. A meta-analysis of some small randomized controlled trials has examined the use of pentoxifylline in NAFLD, documenting a decrease in serum liver enzymes and an improvement in hepatic steatosis, lobular inflammation, and fibrosis (Chalasani et al. 2012; Rinella 2015; Corey and Rinella 2016). These small studies suggest that this drug may have benefit in NASH and has a very good safety profile. However, until more definitive data are available, its impact on NASH remains elusive.

Vitamin D<sub>3</sub> plays a key role in calcium homeostasis and bone mineralization. Vitamin D<sub>3</sub> deficiency is a highly prevalent condition worldwide. Some small studies have demonstrated that patients with NAFLD had significantly lower 25 (OH)-vitamin D<sub>3</sub> levels than those without liver involvement. Again, emerging experimental evidence suggests that low serum vitamin D<sub>3</sub> levels predispose to intrahepatic lipid accumulation and hepatic inflammation, contributing to the development and progression of NAFLD. However, whether vitamin D<sub>3</sub> supplementation ameliorates NAFLD histology is uncertain, and further randomized controlled trials with adequate histological endpoints are needed before its use can be recommended for the specific treatment of NAFLD or NASH (Targher and Byrne 2013).

An interesting novel agent is the insulin sensitizer farnesoid X receptor (FXR) ligand obeticholic acid (i.e., a synthetic variant of the natural bile acid

henodeoxycholic acid that is a potent activator of the FXR). In a multicenter, randomized, placebo-controlled (FLINT) trial of 283 individuals with noncirrhotic NASH (only about half of whom with established T2DM), obeticholic acid treatment was associated with both resolution of NASH and improvement in fibrosis at 72-week liver biopsy (Neuschwander-Tetri et al. 2015). While these are encouraging data, the efficacy and long-term safety features (e.g., pruritus and increased LDL-cholesterol levels with the use of this drug) need to be addressed.

Interestingly, a recent Bayesian network meta-analysis combining direct and indirect treatment comparisons has assessed the comparative effectiveness of pharmacological agents for the treatment of NASH. Collectively, nine randomized, controlled trials including nearly 1,000 patients with biopsy-proven NASH, comparing vitamin E, glitazones, pentoxifylline, or obeticholic acid to one another or placebo, were identified. This Bayesian network meta-analysis revealed only moderate-quality evidence for glitazones, pentoxifylline, and obeticholic acid to decrease lobular inflammation and for pentoxifylline and obeticholic acid to improve hepatic fibrosis (Singh et al. 2015). Collectively, the findings of this meta-analysis do not currently allow for straightforward recommendations for drug treatment of this liver disease.

Promising novel agents with antiinflammatory, antifibrotic, or insulin-sensitizing properties (dual PPAR $\alpha/\delta$  agonists, dual chemokine receptor [CCR]2/CCR5 antagonists, and fatty acid/bile acid conjugates), and antifibrotic agents (anti-lysyl oxidase-like [anti-LOXL2] monoclonal antibodies) are also being tested in late-phase randomized controlled trials in NASH (Ratziu 2016).

Finally, bariatric surgery, as a nonpharmaceutical effective treatment to decrease body weight, insulin resistance, and reverse T2DM, also markedly improves all histological lesions of NASH, including hepatic necroinflammation and fibrosis (Chalasanani et al. 2012; Targher and Byrne 2013; Corey and Rinella 2016; EASL-EASD-EASO clinical practice guidelines 2016). Bariatric surgery should be an accepted treatment option in people who have T2DM and severe obesity (body mass index  $>35$  kg/m<sup>2</sup>). Bariatric surgery should be also considered as an alternative treatment option in patients with a body mass index between 30 and 35 kg/m<sup>2</sup> when T2DM cannot be adequately controlled by optimal medical regimen, especially in the presence of major CVD risk factors. However, while bariatric surgery is undoubtedly effective, there are limitations including complications, patient's acceptability, service availability, and costs. Of note, the possible side effects and long-term consequences of bariatric surgery need to be also considered and weighed against those of lifestyle intervention and drug treatment.

---

## Summary

The perception of NAFLD as an uncommon and benign condition is rapidly changing. Because of its strong association with insulin resistance, NAFLD immediately requires clinical search for features of metabolic syndrome and T2DM. In addition, established T2DM requires thorough clinical testing to rule out concomitant NAFLD/NASH.



Specifically, clinicians have to keep in mind that NAFLD is very common in patients with T2DM or T1DM (affecting about 30–50% of adult patients with T1DM and up to 70–75% of those with T2DM) and that these patients are also more likely to develop more severe forms of NAFLD (NASH, advanced fibrosis, cirrhosis, and, in some cases, HCC). In addition, because of the link between diabetes, NAFLD, and adverse cardiovascular outcomes, more careful surveillance of these at-risk patients will be needed with the combined use of serum liver enzymes, liver imaging, transient elastography, and clinical risk score systems for advanced liver fibrosis.

The possibility of NAFLD should be entertained as a part of the routine evaluation of patients with T2DM, in the same way as microvascular complications and CVD. Additionally, a multidisciplinary approach to the treatment of diabetic patients with NAFLD, based on a careful evaluation of related cardiometabolic risk factors and monitoring for cardiovascular, kidney, and liver complications, is warranted.

---

## References

- Adams LA, Harnsen S, St Sauver JL, Charatcharoenwittaya P, Enders FB, Therneau T, Angulo P. Nonalcoholic fatty liver disease increases risk of death among patients with diabetes: a community-based cohort study. *Am J Gastroenterol*. 2010;105:1567–73.
- Angulo P, Kleiner DE, Dam-Larsen S, Adams LA, Bjornsson ES, Charatcharoenwittaya P, Mills PR, Keach JC, Lafferty HD, Stahler A, Hafflidottir S, Bendtsen F. Liver fibrosis, but no other histologic features, is associated with long-term outcomes of patients with nonalcoholic fatty liver disease. *Gastroenterology*. 2015;149:389–97.
- Anstee QM, Targher G, Day CP. Progression of NAFLD to diabetes mellitus, cardiovascular disease or cirrhosis. *Nat Rev Gastroenterol Hepatol*. 2013;10:330–44.
- Armstrong MJ, Gaunt P, Aithal GP, Barton D, Hull D, Parker R, Hazlehurst JM, Guo K, LEAN trial team, Abouda G, Aldersley MA, Stocken D, Gough SC, Tomlinson JW, Brown RM, Hübscher SG, Newsome PN. Liraglutide safety and efficacy in patients with non-alcoholic steatohepatitis (LEAN): a multicentre, double-blind, randomised, placebo-controlled phase 2 study. *Lancet*. 2016;387:679–790.
- Bazick J, Donithan M, Neuschwander-Tetri BA, Kleiner D, Brunt EM, Wilson L, Doo E, Lavine J, Tonascia J, Loomba R. Clinical model for NASH and advanced fibrosis in adult patients with diabetes and NAFLD: guidelines for referral in NAFLD. *Diabetes Care*. 2015;38:1347–55.
- Byrne CD, Targher G. NAFLD: a multisystem disease. *J Hepatol*. 2015;62:S47–64.
- Castera L, Vilgrain V, Angulo P. Noninvasive evaluation of NAFLD. *Nat Rev Gastroenterol Hepatol*. 2013;10:666–75.
- Chalasanani N, Younossi Z, Lavine JE, Diehl AM, Brunt EM, Cusi K, Charlton M, Sanyal AJ. The diagnosis and management of non-alcoholic fatty liver disease: practice guideline by the American Association for the Study of Liver Diseases, American College of Gastroenterology, and the American Gastroenterological Association. *Hepatology*. 2012;55:2005–23.
- Chen HP, Shieh JJ, Chang CC, Chen TT, Lin JT, Wu MS, Lin JH, Wu CY. Metformin decreases hepatocellular carcinoma risk in a dose-dependent manner: population-based and in vitro studies. *Gut*. 2013;62:606–15.
- Corey KE, Rinella ME. Medical and surgical treatment options for nonalcoholic steatohepatitis. *Dig Dis Sci*. 2016;61:1387–97.
- Cusi K, Orsak B, Bril F, Lomonaco R, Hecht J, Ortiz-Lopez C, Tio F, Hardies J, Darland C, Musi N, Webb A, Portillo-Sanchez P. Long-term pioglitazone treatment for patients with nonalcoholic

- steatohepatitis and prediabetes or type 2 diabetes mellitus: a randomized trial. *Ann Intern Med.* 2016;165:305–15.
- de Marco R, Locatelli F, Zoppini G, Verlato G, Bonora E, Muggeo M. Cause-specific mortality in type 2 diabetes. The Verona Diabetes Study. *Diabetes Care.* 1999;22:756–61.
- Doycheva I, Cui J, Nguyen P, Costa EA, Hooker J, Hofflich H, Bettencourt R, Brouha S, Sirlin CB, Loomba R. Non-invasive screening of diabetics in primary care for NAFLD and advanced fibrosis by MRI and MRE. *Aliment Pharmacol Ther.* 2016;43:83–95.
- European Association for the Study of the Liver (EASL); European Association for the Study of Diabetes (EASD); European Association for the Study of Obesity (EASO). EASL-EASD-EASO clinical practice guidelines for the management of non-alcoholic fatty liver disease. *J Hepatol.* 2016;64:1388–402.
- Harman DJ, Kaye PV, Harris R, Suzuki A, Gazis A, Aithal GP. Prevalence and natural history of histologically proven chronic liver disease in a longitudinal cohort of patients with type 1 diabetes. *Hepatology.* 2014;60:158–68.
- Kwok R, Choi KC, Wong GL, Zhang Y, Chan HL, Luk AO, Shu SS, Chan AW, Yeung MW, Chan JC, Kong AP, Wong VW. Screening diabetic patients for non-alcoholic fatty liver disease with controlled attenuation parameter and liver stiffness measurements: a prospective cohort study. *Gut.* 2016;65:1359–68.
- Lonardo A, Bellentani S, Argo CK, Ballestri S, Byrne CD, Caldwell SH, Cortez-Pinto H, Grieco A, Machado MV, Miele L, Targher G. Non-alcoholic fatty liver disease (NAFLD) study group, dedicated to the memory of Prof. Paola Loria. Epidemiological modifiers of non-alcoholic fatty liver disease: focus on high-risk groups. *Dig Liver Dis.* 2015;47:997–1006.
- Lonardo A, Sookoian S, Pirola CJ, Targher G. Non-alcoholic fatty liver disease and risk of cardiovascular disease. *Metabolism.* 2016;65:1135–50.
- Mantovani A, Ballestri S, Lonardo A, Targher G. Cardiovascular disease and myocardial abnormalities in nonalcoholic fatty liver disease. *Dig Dis Sci.* 2016a;61:1246–67.
- Mantovani A, Rigamonti A, Bonapace S, Bolzan B, Pernigo M, Morani G, Franceschini L, Bergamini C, Bertolini L, Valbusa F, Rigolon R, Pichiri I, Zoppini G, Bonora E, Violi F, Targher G. Nonalcoholic fatty liver disease is associated with ventricular arrhythmias in patients with type 2 diabetes referred for clinically indicated 24-hour Holter monitoring. *Diabetes Care.* 2016b;39:1416–23.
- Michelotti GA, Machado MV, Diehl AM. NAFLD, NASH and liver cancer. *Nat Rev Gastroenterol Hepatol.* 2013;10:656–65.
- Neuschwander-Tetri BA, Loomba R, Sanyal AJ, Lavine JE, Van Natta ML, Abdelmalek MF, Chalasani N, Dasarathy S, Diehl AM, Hameed B, Kowdley KV, McCullough A, Terrault N, Clark JM, Tonascia J, Brunt EM, Kleiner DE, Doo E, NASH Clinical Research Network. Farnesoid X nuclear receptor ligand obeticholic acid for non-cirrhotic, nonalcoholic steatohepatitis (FLINT): a multicentre, randomised, placebo-controlled trial. *Lancet.* 2015;385:956–65.
- Porepa L, Ray JG, Sanchez-Romeu P, Booth GL. Newly diagnosed diabetes mellitus as a risk factor for serious liver disease. *CMAJ.* 2010;182:E526–31.
- Portillo-Sanchez P, Bril F, Maximos M, Lomonaco R, Biernacki D, Orsak B, Subbarayan S, Webb A, Hecht J, Cusi K. High prevalence of nonalcoholic fatty liver disease in patients with type 2 diabetes mellitus and normal plasma aminotransferase levels. *J Clin Endocrinol Metab.* 2015;100:2231–8.
- Ratziu V. Novel pharmacotherapy options for NASH. *Dig Dis Sci.* 2016;61:1398–405.
- Reeves HL, Zaki MY, Day CP. Hepatocellular carcinoma in obesity, type 2 diabetes, and NAFLD. *Dig Dis Sci.* 2016;61:1234–45.
- Rinella ME. Nonalcoholic fatty liver disease: a systematic review. *JAMA.* 2015;313:2263–73.
- Singh S, Singh PP, Singh AG, Murad MH, Sanchez W. Anti-diabetic medications and the risk of hepatocellular cancer: a systematic review and meta-analysis. *Am J Gastroenterol.* 2013;108:881–91.
- Singh S, Khera R, Allen AM, Murad MH, Loomba R. Comparative effectiveness of pharmacological interventions for nonalcoholic steatohepatitis: a systematic review and network meta-analysis. *Hepatology.* 2015;62:1417–32.

- Tang A, Rabasa-Lhoret R, Castel H, Wartelle-Bladou C, Gilbert G, Massicotte-Tisluck K, Chartrand G, Olivié D, Julien AS, de Guise J, Soulez G, Chiasson JL. Effects of insulin glargine and liraglutide therapy on liver fat as measured by magnetic resonance in patients with type 2 diabetes: a randomized trial. *Diabetes Care*. 2015;38:1339–46.
- Targher G, Byrne CD. Nonalcoholic fatty liver disease: a novel cardiometabolic risk factor for type 2 diabetes and its complications. *J Clin Endocrinol Metab*. 2013;98:483–95.
- Targher G, Bertolini L, Padovani R, Rodella S, Tessari R, Zenari L, Day C, Arcaro G. Prevalence of nonalcoholic fatty liver disease and its association with cardiovascular disease among type 2 diabetic patients. *Diabetes Care*. 2007a;30:1212–8.
- Targher G, Bertolini L, Rodella S, Tessari R, Zenari L, Lippi G, Arcaro G. Nonalcoholic fatty liver disease is independently associated with an increased incidence of cardiovascular events in type 2 diabetic patients. *Diabetes Care*. 2007b;30:2119–221.
- Targher G, Bertolini L, Rodella S, Zoppini G, Lippi G, Day C, Muggeo M. Non-alcoholic fatty liver disease is independently associated with an increased prevalence of chronic kidney disease and proliferative/laser-treated retinopathy in type 2 diabetic patients. *Diabetologia*. 2008a;51:444–50.
- Targher G, Chonchol M, Bertolini L, Rodella S, Zenari L, Lippi G, Franchini M, Zoppini G, Muggeo M. Increased risk of CKD among type 2 diabetics with nonalcoholic fatty liver disease. *J Am Soc Nephrol*. 2008b;19:1564–70.
- Targher G, Bertolini L, Padovani R, Rodella S, Zoppini G, Pichiri I, Sorgato C, Zenari L, Bonora E. Prevalence of non-alcoholic fatty liver disease and its association with cardiovascular disease in patients with type 1 diabetes. *J Hepatol*. 2010a;53:713–8.
- Targher G, Bertolini L, Chonchol M, Rodella S, Zoppini G, Lippi G, Zenari L, Bonora E. Non-alcoholic fatty liver disease is independently associated with an increased prevalence of chronic kidney disease and retinopathy in type 1 diabetic patients. *Diabetologia*. 2010b;53:1341–8.
- Targher G, Day CP, Bonora E. Risk of cardiovascular disease in patients with nonalcoholic fatty liver disease. *N Engl J Med*. 2010c;363:1341–50.
- Targher G, Chonchol MB, Byrne CD. CKD and nonalcoholic fatty liver disease. *Am J Kidney Dis*. 2014a;64:638–52.
- Targher G, Mantovani A, Pichiri I, Mingolla L, Cavalieri V, Mantovani W, Pancheri S, Trombetta M, Zoppini G, Chonchol M, Byrne CD, Bonora E. Nonalcoholic fatty liver disease is independently associated with an increased incidence of chronic kidney disease in patients with type 1 diabetes. *Diabetes Care*. 2014b;37:1729–36.
- Targher G, Marchesini G, Byrne CD. Risk of type 2 diabetes in patients with non-alcoholic fatty liver disease: causal association or epiphenomenon? *Diabetes Metab*. 2016a;42:142–56.
- Targher G, Byrne CD, Lonardo A, Zoppini G, Barbui C. Nonalcoholic fatty liver disease and risk of incident cardiovascular disease: a meta-analysis. *J Hepatol*. 2016b;65:589–600.
- Zhang ZJ, Zheng ZJ, Shi R, Su Q, Jiang Q, Kip KE. Metformin for liver cancer prevention in patients with type 2 diabetes: a systematic review and meta-analysis. *J Clin Endocrinol Metab*. 2012;97:2347–53.
- Zoppini G, Fedeli U, Gennaro N, Saugo M, Targher G, Bonora E. Mortality from chronic liver diseases in diabetes. *Am J Gastroenterol*. 2014;109:1020–5.



# Diabetes Secondary to Pancreatic Diseases 17

Teresa Mezza, Francesca Cinti, and Andrea Giaccari

## Contents

Definition and Prevalence .....	524
Causes .....	524
Pancreatitis .....	524
Pancreatic Cancer .....	526
Pancreatic Surgery .....	528
Other Causes .....	529
Clinical Diagnosis .....	531
Management .....	532
Conclusion .....	533
References .....	533

## Abstract

Diabetes secondary to pancreatic diseases is a well-known form of diabetes mellitus, classified as “diseases of the exocrine pancreas – other specific type of diabetes,” or Type 3c diabetes mellitus (T3cDM). Exocrine pancreatic diseases underlying T3cDM include benign and malign conditions, of any etiology, that diffusely injure the pancreas. Due to the heterogeneity of its underlying causes, it is rarely considered in everyday clinical practice, but it could be more common than generally thought. An early diagnosis of a pancreatic disease may substantially change the patient’s prognosis. Finally, endocrinologists should become more acquainted with pancreatic diseases, while all other specialists should attribute the deserved importance to diabetes and hyperglycemia, even in the apparently mild forms. A schematic revision of causes, clinical diagnoses, and management will be discussed in the chapter.

T. Mezza · F. Cinti · A. Giaccari (✉)

Center for Endocrine and Metabolic Diseases, Fondazione Policlinico Universitario A. Gemelli IRCCS, Università Cattolica del Sacro Cuore, Rome, Italy

e-mail: [teresa.mezza@gmail.com](mailto:teresa.mezza@gmail.com); [cinti\\_francesca@hotmail.com](mailto:cinti_francesca@hotmail.com); [andrea.giaccari@unicatt.it](mailto:andrea.giaccari@unicatt.it)

© Springer Nature Switzerland AG 2020

E. Bonora, R. A. DeFronzo (eds.), *Diabetes Complications, Comorbidities and Related Disorders*, Endocrinology, [https://doi.org/10.1007/978-3-030-36694-0\\_18](https://doi.org/10.1007/978-3-030-36694-0_18)

523

---

**Keywords**

Pancreatic diseases · Diabetes secondary · Personalized medicine · Type 3c Diabetes mellitus

---

**Definition and Prevalence**

Diabetes secondary to pancreatic diseases is a well-known form of diabetes mellitus, classified as “diseases of the exocrine pancreas – other specific type of diabetes,” or Type 3c diabetes mellitus (T3cDM) (Expert Committee on the Diagnosis and Classification of Diabetes Mellitus 2003; American Diabetes Association 2011).

Exocrine pancreatic diseases underlying T3cDM include benign and malign conditions, of any etiology, that diffusely injure the pancreas. Due to the heterogeneity of its underlying causes, it is rarely considered in everyday clinical practice, but it could be more common than generally thought. Its prevalence, in fact, has long been underestimated (approx. 0.5–1.15% of all cases of diabetes in North America) (Ganda 1994). Recently, however, awareness of T3cDM has risen, most likely due to the current availability of improved imaging methods to study the pancreas, and noninvasive screening to quantify exocrine dysfunctions. Indeed, a recent review on its prevalence, pathophysiology, and cancer associations asserts that T3cDM accounts for up to 5–10% of cases in Western populations, and is associated with mild to severe disease (Cui and Andersen 2011; Ewald et al. 2012). This growing type of diabetes mellitus, characterized by specific clinical and laboratory features, distinct from both type 1 and type 2 diabetes mellitus, will probably attract increasing attention in endocrinology and gastroenterology in the coming years.

---

**Causes**

A recent study by Ewald et al. affirms that 78.5% of T3cDM cases can be ascribed to chronic pancreatitis, followed by pancreatic cancer (8%), hereditary hemochromatosis (7%), cystic fibrosis (4%), and pancreatectomy (2%). Interestingly, 49% of cases were initially misclassified as type 2 diabetes mellitus, highlighting the underestimation of the role of pancreatic disease in the development of diabetes (Ewald et al. 2012; Hardt et al. 2008).

**Pancreatitis**

Transient hyperglycemia is observed in about 50% of patients with acute pancreatitis, even though it persists as DM in only 1–15% of these patients (Bank et al. 1975; Ibars et al. 2002).

On the other hand, the prevalence of DM in chronic pancreatitis (CP) varies between 30% and 83% (Angelopoulos et al. 2005; Koizumi et al. 1998).

CP is a progressive, destructive, and inflammatory process of multifactorial etiology that leads to irreversible necrosis of the exocrine and endocrine pancreatic tissue and to its replacement with fibrous tissue. Several theories have been proposed to explain the pathophysiology of CP. In fact, different observations lend credence to a close relationship between acute pancreatitis, recurrent acute pancreatitis, and the development of CP. Recurrent exposure to injurious factors provokes an inflammatory response and, as a consequence, released cytokines attract a specific cellular infiltrate, whereas profibrotic cells, including stellate cells, determine pancreatic fibrosis (Omary et al. 2007; Sparmann et al. 2004; Apte et al. 2004; Jaster 2004).

To cope with fibrosis, some duct cells in the pancreas of patients with chronic pancreatitis develop the capacity to differentiate into cells capable of producing proteins normally associated with either pancreatic endocrine or exocrine tissue (Cooke et al. 2001). In particular, the comparison of pancreata of patients with chronic pancreatitis with controls show an increased number of proliferating cells and a greater number of cells containing insulin, glucagon, PDX1, and amylase in the ducts of the former.

These findings prove that adult pancreatic ductal cells have the capability to undergo altered differentiation (metaplasia) (Phillips et al. 2007). On the other hand, Schneide et al. found no increase in beta cell turnover in CP patients, despite severe damage in the exocrine compartment (Schneider et al. 2009). Although the endocrine cells seem to preserve an “immune-privileged” status and an active anti-apoptotic program through the NF- $\kappa$ B pathway, beta cell function and glucose tolerance decline in concomitance with increasing disease duration (Nyboe Andersen et al. 1982; Schneider et al. 1985; Larsen et al. 1987) and accumulating pancreatic calcifications.

The mechanisms underlying glucose impairment in chronic pancreatitis are as yet not completely clear; however, fibrotic scars surrounding pancreatic islets could determine altered microcirculation and, consequently, affect islet health.

Insulin response to various secretagogues, i.e., intravenous and oral glucose, arginine, glucagon, and sulfonylureas, has consistently been demonstrated to be blunted in DM secondary to CP (Deckert et al. 1972; Anderson et al. 1970; Joffe et al. 1968; Kalk et al. 1974) and these responses worsen with the magnitude of exocrine dysfunction. Patients with CP, compared to type 1 diabetics and healthy controls, have been described as either more insulin sensitive (Nosadini et al. 1982) or more insulin resistant (Yki-Jarvinen et al. 1986); this suggests a variability among study populations and in different factors affecting insulin sensitivity.

Likewise, there are conflicting results also in terms of glucagon concentrations: increased glucagon levels are often present in acute pancreatitis (Donowitz et al. 1975) probably explaining the transient hyperglycemia that frequently characterizes this condition. However, in the chronic phase of pancreatitis, glucagon levels are either reduced (Linde et al. 1977), normal (Ohneda et al. 1976), or elevated (Kannan et al. 1979), as glucagon response to oral glucose, meal ingestion, or intravenous arginine, respectively (Donowitz et al. 1975).

Furthermore, CP and exocrine dysfunction have been associated with a functional impairment of the incretin system, which is therefore likely to contribute to post-prandial hyperglycemia in diabetes. In fact, patients with alcoholic pancreatitis

display reduced GIP production, while impaired fat hydrolysis plays an important role in GLP-1 production; these defects can be easily normalized by pancreatic enzyme supplementation (Ebert and Creutzfeldt 1980; Beglinger et al. 2010).

Another reason why CP might be involved in the pathogenesis of diabetes lies in the fact that it predisposes toward the development of pancreatic cancer, the second most frequent cause of T3cDM (Ewald et al. 2012). In the inflammatory environment, cytokines, chemokines, and activated signaling pathways might play a role in the transformation of normal duct epithelium into metaplastic and early neoplastic lesions that can lead to pancreatic cancer (Farrow and Evers 2002).

Long-standing duct obstruction and ductal pressure caused by pancreatic fibrosis have also been considered responsible for the activation of signaling pathways by promoting cellular transformation (Bhanot and Moller 2009). Although ductal cells have long been regarded as the exclusive origin of pancreatic ductal carcinoma, based on tumor histology and the presence of ductal preneoplastic lesions, several recent studies using linear tracing in mice have shown that pancreatic duct adenocarcinoma can also arise from acinar cells (Guerra et al. 2007).

## Pancreatic Cancer

Although the association between diabetes and pancreatic cancer (PC) has been established in several cohort studies (Ben et al. 2011), the relationship is still controversial (Bartosch-Harlid and Andersson 2010). T2D is a major risk factor for the development of pancreatic cancer (following smoking and obesity) and the T2D epidemic has been suggested as responsible, at least in part, for the increase in the incidence of pancreatic cancer (Bartosch-Harlid and Andersson 2010; Li 2012). Likewise, about 80% of pancreatic cancer patients, at the time of diagnosis, have either impaired glucose tolerance or diabetes (Permert et al. 1993a; Chari et al. 2008), but the exact mechanisms behind the development of DM in patients with PC are unclear. This observation has led to debate as to whether PC causes DM or DM is a risk factor for the development of PC (Wang et al. 2003). Thus, increased peripheral insulin resistance, tumor-derived factors causing DM, and T2DM increasing the risk for PC are all postulated with varying degrees of evidence, but it appears that intrapancreatic tumors and/or other preoperative features could directly affect endocrine function.

Several studies have demonstrated that diabetes in PC patients is characterized by peripheral insulin resistance (Permert et al. 1993a; Schwarts et al. 1978; Gullo et al. 1994), which markedly improves 3 months after tumor resection (Permert et al. 1993a). These data suggest that the insulin resistance and diabetes seen in pancreatic cancer patients might be causally related to the pancreatic tumors. In this regard, several studies have demonstrated *in vitro* that the insulin signaling cascade in skeletal muscle is impaired by pancreatic cancer at multiple steps, e.g., phosphatidylinositol 3-kinase (PI3-K) activity and glucose transport glycogen synthase activity (Isaksson et al. 2003; Liu et al. 1998).

Besides insulin resistance, islet dysfunction also plays a role in the pathogenesis of diabetes associated with pancreatic cancer. In fact, insulin secretion in response to classic stimuli is reduced (Fox et al. 1985; Wang et al. 1997) and a relative increase in proinsulin over insulin levels has also been observed in pancreatic cancer patients (Nakamori et al. 1999), suggesting that the maturation of proinsulin may also be affected by the tumor. These functional abnormalities are directly linked to changes in islet hormone circulating levels (Permert et al. 1997) and also to morphological abnormalities of the pancreatic islets adjacent to the pancreatic carcinoma, which display an abnormal colocalization of islet hormones in islet cells (Pour et al. 1993).

It is speculated that the reason for impaired glucose metabolism in most patients is the alteration of islet cells, either by the carcinoma directly or by diabetogenic substances released by cancer cells. One of the possible substances with diabetogenic effects is islet amyloid polypeptide (IAPP), normally produced in islet beta cells and coreleased with insulin at a constant ratio. Endogenous IAPP reduces arginine-stimulated insulin, glucagon, and somatostatin release (Wang et al. 1999). Elevated plasma levels of IAPP are found in patients with PC, while the number of IAPP-expressing cells are significantly lower in patients with DM and in the tumor areas, but not in the tumor-free regions, of individuals with PC (Permert et al. 1993b, 1994; Katsumichi and Pour 2007). Also, the improvement in glucose tolerance seen after tumor removal is associated with normalization of circulating IAPP levels (Permert et al. 1994), suggesting that the increased IAPP release seen in pancreatic cancer patients may be responsible, at least in part, for the islet dysfunction found in these individuals.

Recently, a 14-amino acid peptide was identified in the extract of PC cells of diabetic patients. This peptide corresponds to the *N*-terminal of the S100A8. It is claimed that this peptide is produced in the mitochondria of cancer and inflammatory cells. A list of S100-derived peptides have also been identified in PC, and the list seems to be growing (Basso et al. 2005, 2006).

Many prospective cohort and case control studies have conclusively shown that long-standing DM increases the risk of subsequent death from PC about twofold. A meta-analysis performed by Everhart and Wright stated that pancreatic cancer could be added to the list of diabetic complications (Everhart and Wright 1995). However, other epidemiological studies have concluded that diabetes is not a risk factor for pancreatic cancer or, at any rate, that it is not a risk factor if recently-diagnosed cases are excluded (Gullo 1999; Hjalgrim et al. 1997; Frye et al. 2000). Studies on the relationship between diabetes and pancreatic cancer are complicated by the fact that diabetes has two major forms that are different entities in terms of pathophysiology, several treatments, and concomitant risk factors.

Despite the uncertainty regarding cause–effect relationship between diabetes and pancreatic cancer, glucose metabolism abnormalities associated with PC can either improve postoperatively or worsen following surgical procedures (Saruc and Pour 2003).



## Pancreatic Surgery

The incidence of DM after pancreatic surgery varies with the different surgical procedures and the underlying etiology of disease.

Indications for surgery are the attempted amelioration of intractable pain, CP complications (biliary obstruction, duodenal stenosis, pancreatic duct stenosis, pseudocysts, pancreatic ascites, portal venous compression from splenic/mesenteric venous thrombosis, pancreatic hemorrhage), and resection of pancreatic or peri-ampullary tumors. Any surgical intervention aims to preserve as much of the functioning pancreatic parenchyma as possible.

The metabolic abnormalities after pancreatic resection are dependent on the specific operation performed, the area (proximal vs. distal) of the pancreas, and the percentage of the gland removed.

Several animal models of pancreas ablation, e.g., streptozotocin-administered baboons (McCulloch et al. 1991; Leahy et al. 1994) or variable pancreatectomy in rats (Leahy et al. 1994; Liu et al. 2000; Bonner-Weir et al. 1983), have shown a lower rate of development of diabetes than expected, suggesting that beta cell regeneration and/or appearance of new small islets could compensate for decreasing beta cell mass. In humans, a 50% pancreatectomy in healthy donors induces impaired glucose tolerance in 25% of patients, but no development of diabetes (Kendall et al. 1990).

A number of interesting studies suggest that a reduction in beta cell mass may also reduce glucose disposal in the peripheral tissues. In the dogs studied by Matveyenko et al. (2006), a 50% pancreatectomy resulted in impaired fasting glucose or impaired glucose tolerance, a reduction in the pulse mass of glucose-induced insulin secretion, a decrease in hepatic insulin extraction, and a 40% reduction in insulin-stimulated glucose disposal. These findings raise the provocative possibility that beta cell mass reduction may not only have effects on insulin secretion, but may also play a role in the impaired insulin action.

The distribution of hormone-producing cells in the pancreas is one of the main prognostic factors in the incidence of new, or worsening of existing, DM that can occur after pancreatic surgery. Evidence in humans shows that insulin-producing beta cells are distributed evenly throughout the pancreas, as is cellular composition and islet architecture, with no regional difference in glucose-stimulated insulin secretion in islets isolated from different pancreas portions. However, islet density and distribution has been recently suggested to be twofold higher in the tail region compared to head and body region (Wang et al. 2013). This suggests that distal pancreatectomy, besides the effects of the radically different surgical procedure, could have a different impact on glucose metabolism compared to resection of the head region, solely in terms of the mass of beta cells removed.

Proximal pancreatectomy is recommended for patients with CP who have pain or biliary or duodenal obstruction, and major disease in the head of the gland. These procedures include the conventional pancreaticoduodenectomy (Whipple's operation), pylorus-preserving pancreaticoduodenectomy, Beger's duodenum-preserving pancreatic head resection, and Frey's longitudinal pancreaticojejunostomy combined with local pancreatic head excision. The consequent metabolic disturbance is

proportional to the extent of gland resection, although, due to pancreatic vascularization, such proportions do not differ greatly. The duodenum-preserving method and Frey's procedure appear superior to Whipple's procedure and may also be superior to the pylorus-preserving procedure. The postoperative DM rate is about 10–25% in Frey's procedure and 7.5–21% in Beger's procedure. In a randomized prospective trial of 20 patients, Buchler et al. showed improvement of glucose tolerance in patients whose duodenum was preserved compared with the others. Distal pancreatectomy is indicated for lesions of the body and tail of the pancreas and involves removing the distal part of the pancreas with or without splenectomy. In distal pancreatectomy, DM does not seem to develop unless 60% or more of the gland is removed (Hutchins et al. 2002; King et al. 2008; Slezak and Andersen 2001; Massucco et al. 2001). Long-term results of distal pancreatectomy for CP in 90 patients also showed a DM risk of 46% over 2 years. The extent of pancreatectomy is significantly associated with the development of DM. Splenic conservation is linked to reduced incidence of postoperative DM in pancreatectomy, with rates varying from 34% to 75% (King et al. 2008).

Regardless of the extent and region of pancreas removal, it has also been shown that various intraoperative techniques used to manage pancreatic remnant, aiming to decrease the risk of the dreaded complications related to pancreatic anastomosis (Paye 2010), impact on residual beta cell function and diabetes risk (Mezza et al. 2015). Pancreatic duct occlusion with different types of glue during pancreatectomy has led to a marked reduction in mortality, but has been criticized for causing major impairment of the endocrine function of the pancreas (Suc et al. 2003). The degree of reduction of insulin secretion after surgery was higher after pancreatic duct occlusion compared to other techniques, as acrylic glue negatively affects pancreatic endocrine function acutely after pancreatectomy but does not determine a worsening in long-term endocrine recovery response and diabetes management. This may be due to progressive fibrosis of the gland involving pancreatic islets or to the adverse effects of injected glue on the endocrine compartments.

## Other Causes

Additional common causes of T3cDM are cystic fibrosis and iron-overload-linked conditions, such as hemochromatosis and thalassemia (Koch et al. 2001; Ewald et al. 2012).

Over the past 20 years, the prevalence of cystic fibrosis-related diabetes (CFRD) and impaired glucose tolerance (IGT) has risen dramatically. The ADA places CFRD in the “other specific type – disease of the exocrine pancreas” category. In this case, the manifestations are primarily caused by pancreatic damage, which reduces insulin secretion, even though glucose tolerance is also modified by factors that alter insulin resistance, such as intercurrent illness and infections. The pancreas is histologically abnormal in almost all CF patients and pancreatic ischemic damage induces consequent autolysis. The mutation in the cystic fibrosis transmembrane conductance regulator (CFTR) protein represents the pathogenic mechanism leading to reduced

fluid secretion into the pancreaticobiliary ducts and consequent obstruction of the pancreatic ducts due to protein precipitation (Gaskin et al. 1982; Kopelman et al. 1988). Deposition of islet amyloid may also contribute to impairment of endocrine pancreatic function in people with CF. Interestingly, the majority of CF patients with exocrine pancreatic damage do not develop glucose intolerance.

CFRD patients have a sixfold higher mortality rate than CF patients without DM (Moran et al. 1999). CFRD is associated with accelerated pulmonary functional decline. Hyperglycemia may cause pulmonary damage via a number of mechanisms, including the combined effects of cellular stress and damage to the lung parenchyma. Insulin therapy in people with CFRD restored FEV1 and FVC to the levels recorded at the start of the 6-year period. Insulin also enhances the nutritional state and temporarily improves pulmonary function in CFRD patients, on average delaying the decline in FEV1 by 34 months (Mohan et al. 2008; van den Berg et al. 2008).

Hereditary hemochromatosis (HH) and thalassemia represent pathologic conditions due to iron overload that directly impact diabetes risk (Buyschaert et al. 1997; Moirand et al. 1997), and transfusion iron overload (Dmochowski et al. 1993; Merkel et al. 1988).

Hereditary hemochromatosis is inherited in an autosomal recessive pattern, as a result of mutations of HFE genes in approximately 5 per 1,000 Caucasians of northern European descent (Pietrangelo 2010). HH was originally described as a triad of diabetes, cirrhosis, and skin pigmentation. Recent observations show the prevalence of diabetes to be 13–22% and impaired glucose tolerance 18–30% (Hatunic et al. 2010a; Abraham et al. 2006). The pathophysiology of diabetes associated with HH is controversial, with evidence suggesting that both insulin deficiency and insulin resistance are contributing factors (Hramiak et al. 1997; Mendler et al. 1999). HH induces decreased insulin secretion, while insulin sensitivity tends to increase (McClain et al. 2006); diabetes usually results when insulin resistance develops due to an independent mechanism such as obesity. Individuals with HH are highly prone to develop diabetes when they become, for other reasons, insulin resistant, as they cannot cope with increased insulin secretion caused by altered beta cell function (McClain et al. 2006). In fact, phlebotomy treatment may improve insulin secretion, but not insulin sensitivity (Abraham et al. 2006; Hatunic et al. 2010b). Evidences from mouse models of HH (Cooksey et al. 2004) confirm that the HH phenotype is insulin sensitive, with reduced insulin secretory capacity secondary to oxidative stress, decreased glucose-stimulated insulin secretion, and increased beta cell apoptosis, supporting the hypothesis that insulin resistance is a causal but secondary (to other conditions) factor in HH diabetes (Simcox and McClain 2013). Mechanistically, oxidative stress in islets and other tissues is caused directly by the generation of free radicals from iron reacting with hydrogen peroxide (Fenton chemistry). In addition, iron interferes with the trafficking of other transition metals. Mitochondrial uptake of manganese ( $Mn^{2+}$ ) is inhibited, resulting in decreased metalation and activity of superoxide dismutase 2 (SOD2). Much of the oxidant damage, however, can be ameliorated by Mn supplementation (Jouihan et al. 2008).

On the other hand, patients with thalassemia develop iron overload because of transfusions required to maintain adequate erythrocyte levels, as well as from

increased iron absorption (Weatherall 1998). The prevalence of diabetes in thalassemia patients is 6–14% (Borgna-Pignatti et al. 2004; Vogiatzi et al. 2009). Several studies have shown that insulin resistance and insulin deficiency characterize both prediabetes and diabetes in thalassemia (Dmochowski et al. 1993; Merkel et al. 1988; Messina et al. 2002).

---

## Clinical Diagnosis

Patients with T3cDM are often misclassified. This may be due to poor awareness of this type of diabetes and the lack of generally accepted diagnostic criteria. As with other types of diabetes, T3cDM is diagnosed on the basis of specific features. Ewald and Bretzel (2013) have proposed major and minor criteria for the diagnosis of T3cDM.

### Major criteria (all must be fulfilled):

1. The presence of pancreatic exocrine insufficiency (according to monoclonal fecal elastase 1 test or direct function tests)
2. Evidence of pathological pancreatic imaging (endoscopic ultrasound, MRI, or CT)
3. Absence of type 1 diabetes mellitus (T1DM) autoimmune markers

### Minor criteria:

1. Impaired beta cell function (e.g., HOMA-B, C-peptide/glucose ratio)
2. No excessive insulin resistance (e.g., HOMA-IR)
3. Impaired incretin secretion (e.g., GLP-1, pancreatic polypeptide)
4. Low serum levels of lipid soluble vitamins (A, D, E, and K)

At the presentation of diabetes, exclusion of T1DM is easily accomplished through routine endocrinological assessment of T1DM-associated autoantibodies, whereas distinguishing T3cDM from T2DM is more challenging, since the latter is fairly common (8% of general population) in patients with pancreatic disease. An overlap of different forms can frequently occur, since longstanding type 1 or type 2 diabetes may lead to pancreatic exocrine dysfunctions (Hardt et al. 2000), due to a higher risk of developing acute and/or chronic pancreatitis and pancreatic cancer (Noel et al. 2009; Moriai et al. 2000; Ogunleye et al. 2009; Huxley et al. 2005).

A careful clinical and anamnestic evaluation should be made to establish the presence of T3cDM. Indeed, people with a personal or family history of pancreatitis usually have exocrine dysfunctions before developing endocrine insufficiency. In this case, abdominal pain, steatorrhea, or maldigestion with nutritional deficiencies will occur in the anamnesis.

Another clinical feature that should be investigated is the presence of severe hypoglycemic episodes in diabetic patients. T3cDM arises from diffuse pancreatic alteration that leads to a decrease, not only of islet beta cell secretion of insulin, but also of counterregulatory glucagon secretion from islet alpha cells (Donowitz et al. 1975; Ohneda et al. 1976; Larsen et al. 1988).

In everyday clinical practice, the above criteria help not only to classify the patient at the presentation of diabetes but also to reclassify a long-standing diabetic who is developing another class of diabetes. In this regard, for example, considering the link between diabetes and cancer, an excessive weight loss uncorrelated with the severity of diabetes should not be underestimated, which might represent an early indication of the development of pancreatic cancer.

---

## Management

To date, there are no specific guidelines for the treatment of T3cDM.

At PancreasFest 2012, a consensus conference of gastroenterologists, endocrinologists, and surgeons reviewed the treatment options for chronic pancreatitis-associated diabetes and established recommendations (Rickels et al. 2013). The physician will face two main problems: brittle diabetes that swings from a mild to a severe form, with frequent episodes of hypoglycemia (Alberti 1988), and qualitative malnutrition, especially in terms of fat hydrolysis and fat-soluble vitamins (A, D, E, K). Due to the lack of specific guidelines for T3cDM therapy, diabetes management should follow type 2 diabetes mellitus recommendations. Thus, metformin therapy represents the first choice of treatment, as recommended by the ADA/EASD Consensus, also in this form of diabetes (Nathan et al. 2009). It is worth mentioning that metformin therapy might also be a successful strategy due to its antineoplastic effects, and may be especially beneficial in patients with T3cDM caused by chronic pancreatitis (Sadeghi et al. 2012). The disadvantage of metformin treatment, however, is represented by its common side effects, which include nausea, abdominal complaints, diarrhea, and weight reduction. These side effects may prove intolerable in patients with chronic pancreatitis.

When hyperglycemia becomes severe ( $\text{HbA1c} > 8\%$ ), insulin therapy is the preferred treatment for most patients, especially in cases of CFRD, in acutely ill or hospitalized patients, and severely malnourished patients. In advanced T3cDM, multidose basal-bolus insulin dosing and regimens should follow guidelines for the treatment of T1DM, and include carbohydrate counting for flexible prandial coverage and consideration of continuous subcutaneous insulin infusion or “pump” delivery, always bearing in mind the reduced glucagon secretion and the consequently more severe hypoglycemic episodes. In patients with severe malnutrition, insulin therapy is commonly used as a therapy of first choice. This is due to the desired anabolic effects of insulin in this special subset of patients.

As mentioned above, the physician will also need to handle a qualitative malnutrition situation that, if not adequately corrected, may worsen the diabetic situation at different points. For example, concerning the absorption of fat-soluble vitamins, a deficit of vitamin D has been described in more than 90% of patients with chronic pancreatitis (Sikkens et al. 2013) and its role in the pathogenesis of type 1 and type 2 diabetes is currently under study (Dalgard et al. 2011; Boucher 2011; Ford et al. 2011). Measuring serum-25-hydroxyvitamin D levels and supplementation in deficient patients might thus be beneficial.

Another crucial step, associated with exocrine dysfunction, is the impairment of the incretin system, which is directly dependent on fat hydrolysis. Considering that the majority of T3cDM patients cannot assume incretin therapy (i.e., GLP-1 receptor agonists and DPP-4 inhibitors) because of their side effects (higher risk of increased pancreatic enzymes and/or, for GLP-1 RA only, high frequency of prominent gastrointestinal side effects), an adequate oral pancreatic enzyme replacement, as previously described, becomes mandatory for these patients (Ebert and Creutzfeldt 1980; Beglinger et al. 2010; Kuo et al. 2011).

Besides conventional drugs, any treatment should be combined with efforts to correct lifestyle factors that contribute to hyperglycemia and the risk of pancreatic malignancy (e.g., from the abolition of alcohol and tobacco, weight loss in overweight subjects, physical exercise, and dietary modifications).

---

## Conclusion

A number of considerations can be made on diabetes secondary to pancreatic exocrine diseases. Firstly, while its pathogenesis is always dependent on insulin secretion deficits, its appearance is strongly influenced by the concomitant presence of insulin resistance. Hyperglycemia appears only when the decreased insulin secretion is unable to cope with the insulin request. This implies that the severity of diabetes does not always correlate with the severity of the pancreatic diseases. Further, insulin request (insulin resistance) may vary with time (obesity, concomitant diseases, aging), implying that hyperglycemia may appear (and disappear) with different timing from the primary pancreatic disease. Secondly, while a severe pancreatic disease alerts the clinician to screen for hyperglycemia, diabetes per se does not compel the clinician to screen for pancreatic diseases. Although only a minor part of the cases of secondary diabetes are misdiagnosed as type 2 diabetes, this possibility should always be kept in mind, especially when other symptoms (including weight loss, abdominal pain, digestive disturbances, malabsorption) are reported. An early diagnosis of a pancreatic disease may substantially change the patient's prognosis. Finally, endocrinologists should become more acquainted with pancreatic diseases, while all other specialists should attribute the deserved importance to diabetes and hyperglycemia, even in the apparently mild forms. A closer cooperation between endocrinologists and other specialists is recommended.

---

## References

- Abraham D, Rogers J, Gault P, Kushner JP, McClain DA. Increased insulin secretory capacity but decreased insulin sensitivity after correction of iron overload by phlebotomy in hereditary haemochromatosis. *Diabetologia*. 2006;49:2546–51.
- Alberti KGMM. Diabetes secondary to pancreatopathy: an example of brittle diabetes. In: Tiengo AAK, Del Prato S, Vranic M, editors. *Diabetes secondary to pancreatopathy. Proceedings of the post EASD international symposium on diabetes secondary to pancreatopathy*,

- Padova, 21–22 September 1987. International congress series 762. Amsterdam: Excerpta Medica; 1988. p. 211–4.
- American Diabetes Association. Diagnosis and classification of diabetes mellitus. *Diabetes Care*. 2011;34(Suppl 1):S62–9.
- Anderson MF, Davison SH, Dick AP, Hales CN, Owens J. Plasma insulin in pancreatic disease. *Gut*. 1970;11:524–31.
- Angelopoulos N, Dervenis C, Goula A, Rombopoulos G, Livadas S, Kaltsas D, Kaltzidou V, Tolis G. Endocrine pancreatic insufficiency in chronic pancreatitis. *Pancreatology*. 2005; 5:122–31.
- Apte MV, Park S, Phillips PA, Santucci N, Goldstein D, Kumar RK, Ramm GA, Buchler M, Friess H, McCarroll JA, Keogh G, Merrett N, Pirola R, Wilson JS. Desmoplastic reaction in pancreatic cancer: role of pancreatic stellate cells. *Pancreas*. 2004;29:179–87.
- Bank S, Marks IN, Vinik AI. Clinical and hormonal aspects of pancreatic diabetes. *Am J Gastroenterol*. 1975;64:13–22.
- Bartosch-Harlid A, Andersson R. Diabetes mellitus in pancreatic cancer and the need for diagnosis of asymptomatic disease. *Pancreatology*. 2010;10:423–8.
- Basso D, Greco E, Fogar P, Pucci P, Flagiello A, Baldo G, Giunco S, Valerio A, Navaglia F, Zambon CF, Pedrazzoli S, Plebani M. Pancreatic cancer-associated diabetes mellitus: an open field for proteomic applications. *Clin Chim Acta*. 2005;357:184–9.
- Basso D, Greco E, Fogar P, Pucci P, Flagiello A, Baldo G, Giunco S, Valerio A, Navaglia F, Zambon CF, Falda A, Pedrazzoli S, Plebani M. Pancreatic cancer-derived S-100A8 N-terminal peptide: a diabetes cause? *Clin Chim Acta*. 2006;372:120–8.
- Beglinger S, Drewe J, Schirra J, Goke B, D'Amato M, Beglinger C. Role of fat hydrolysis in regulating glucagon-like peptide-1 secretion. *J Clin Endocrinol Metab*. 2010;95:879–86.
- Ben Q, Xu M, Ning X, Liu J, Hong S, Huang W, Zhang H, Li Z. Diabetes mellitus and risk of pancreatic cancer: a meta-analysis of cohort studies. *Eur J Cancer*. 2011;47:1928–37.
- Bhanot UK, Moller P. Mechanisms of parenchymal injury and signaling pathways in ectopic ducts of chronic pancreatitis: implications for pancreatic carcinogenesis. *Lab Invest*. 2009;89:489–97.
- Bonner-Weir S, Trent DF, Weir GC. Partial pancreatectomy in the rat and subsequent defect in glucose-induced insulin release. *J Clin Invest*. 1983;71:1544–53.
- Borgna-Pignatti C, Rugolotto S, De Stefano P, Zhao H, Cappellini MD, Del Vecchio GC, Romeo MA, Forni GL, Gamberini MR, Ghilardi R, Piga A, Cnaan A. Survival and complications in patients with thalassemia major treated with transfusion and deferoxamine. *Haematologica*. 2004;89:1187–93.
- Boucher BJ. Vitamin D insufficiency and diabetes risks. *Curr Drug Targets*. 2011;12:61–87.
- Buyschaert M, Paris I, Selvais P, Hermans MP. Clinical aspects of diabetes secondary to idiopathic haemochromatosis in French-speaking Belgium. *Diabetes Metab*. 1997;23:308–13.
- Chari ST, Leibson CL, Rabe KG, Timmons LJ, Ransom J, de Andrade M, Petersen GM. Pancreatic cancer-associated diabetes mellitus: prevalence and temporal association with diagnosis of cancer. *Gastroenterology*. 2008;134:95–101.
- Cooke A, Phillips JM, Parish NM. Tolerogenic strategies to halt or prevent type 1 diabetes. *Nat Immunol*. 2001;2:810–5.
- Cooksey RC, Jouihan HA, Ajioka RS, Hazel MW, Jones DL, Kushner JP, McClain DA. Oxidative stress, beta-cell apoptosis, and decreased insulin secretory capacity in mouse models of hemochromatosis. *Endocrinology*. 2004;145:5305–12.
- Cui Y, Andersen DK. Pancreatogenic diabetes: special considerations for management. *Pancreatology*. 2011;11:279–94.
- Dalgard C, Petersen MS, Weihe P, Grandjean P. Vitamin D status in relation to glucose metabolism and type 2 diabetes in septuagenarians. *Diabetes Care*. 2011;34:1284–8.
- Deckert T, Kolendorf K, Persson I, Worning H. Insulin secretion after tolbutamide and after secretin in patients with pancreatic diseases. *Acta Med Scand*. 1972;192:465–70.
- Dmochowski K, Finegood DT, Francombe W, Tyler B, Zinman B. Factors determining glucose tolerance in patients with thalassemia major. *J Clin Endocrinol Metab*. 1993;77:478–83.

- Donowitz M, Hendler R, Spiro HM, Binder HJ, Felig P. Glucagon secretion in acute and chronic pancreatitis. *Ann Intern Med.* 1975;83:778–81.
- Ebert R, Creutzfeldt W. Reversal of impaired GIP and insulin secretion in patients with pancreatogenic steatorrhea following enzyme substitution. *Diabetologia.* 1980;19:198–204.
- Everhart J, Wright D. Diabetes mellitus as a risk factor for pancreatic cancer. A meta-analysis. *JAMA.* 1995;273:1605–9.
- Ewald N, Bretzel RG. Diabetes mellitus secondary to pancreatic diseases (type 3c) – are we neglecting an important disease? *Eur J Intern Med.* 2013;24:203–6.
- Ewald N, Kaufmann C, Raspe A, Kloer HU, Bretzel RG, Hardt PD. Prevalence of diabetes mellitus secondary to pancreatic diseases (type 3c). *Diabetes Metab Res Rev.* 2012;28:338–42.
- Expert Committee on the Diagnosis and Classification of Diabetes Mellitus. Report of the expert committee on the diagnosis and classification of diabetes mellitus. *Diabetes Care.* 2003; 26(Suppl 1):S5–20.
- Farrow B, Evers BM. Inflammation and the development of pancreatic cancer. *Surg Oncol.* 2002;10:153–69.
- Ford ES, Zhao G, Tsai J, Li C. Associations between concentrations of vitamin D and concentrations of insulin, glucose, and HbA1c among adolescents in the United States. *Diabetes Care.* 2011;34:646–8.
- Fox JN, Frier BM, Armitage M, Ashby JP. Abnormal insulin secretion in carcinoma of the pancreas: response to glucagon stimulation. *Diabet Med.* 1985;2:113–6.
- Frye JN, Inder WJ, Dobbs BR, Frizelle FA. Pancreatic cancer and diabetes: is there a relationship? A case-controlled study. *Aust N Z J Surg.* 2000;70:722–4.
- Ganda O. Secondary forms of diabetes. In: Kahn CR, Weir GC, editors. *Joslin's diabetes mellitus.* New York: Lea & Febiger; 1994.
- Gaskin KJ, Durie PR, Corey M, Wei P, Forstner GG. Evidence for a primary defect of pancreatic HCO<sub>3</sub>-secretion in cystic fibrosis. *Pediatr Res.* 1982;16:554–7.
- Guerra C, Schuhmacher AJ, Canamero M, Grippo PJ, Verdaguer L, Perez-Gallego L, Dubus P, Sandgren EP, Barbacid M. Chronic pancreatitis is essential for induction of pancreatic ductal adenocarcinoma by K-Ras oncogenes in adult mice. *Cancer Cell.* 2007;11:291–302.
- Gullo L. Diabetes and the risk of pancreatic cancer. *Ann Oncol.* 1999;10(Suppl 4):79–81.
- Gullo L, Pezzilli R, Morselli-Labate AM, Italian Pancreatic Cancer Study Group. Diabetes and the risk of pancreatic cancer. *N Engl J Med.* 1994;331:81–4.
- Hardt PD, Krauss A, Bretz L, Porsch-Ozcurumez M, Schnell-Kretschmer H, Maser E, Bretzel RG, Zekhorn T, Klor HU. Pancreatic exocrine function in patients with type 1 and type 2 diabetes mellitus. *Acta Diabetol.* 2000;37:105–10.
- Hardt PD, Brendel MD, Kloer HU, Bretzel RG. Is pancreatic diabetes (type 3c diabetes) underdiagnosed and misdiagnosed? *Diabetes Care.* 2008;31(Suppl 2):S165–9.
- Hatunic M, Finucane FM, Brennan AM, Norris S, Pacini G, Nolan JJ. Effect of iron overload on glucose metabolism in patients with hereditary hemochromatosis. *Metabolism.* 2010a; 59:380–4.
- Hatunic M, Finucane FM, Norris S, Pacini G, Nolan JJ. Glucose metabolism after normalization of markers of iron overload by venesection in subjects with hereditary hemochromatosis. *Metabolism.* 2010b;59:1811–5.
- Hjalgrim H, Frisch M, Ekbom A, Kyvik KO, Melbye M, Green A. Cancer and diabetes – a follow-up study of two population-based cohorts of diabetic patients. *J Intern Med.* 1997;241:471–5.
- Hramiak IM, Finegood DT, Adams PC. Factors affecting glucose tolerance in hereditary hemochromatosis. *Clin Invest Med.* 1997;20:110–8.
- Hutchins RR, Hart RS, Pacifico M, Bradley NJ, Williamson RC. Long-term results of distal pancreatectomy for chronic pancreatitis in 90 patients. *Ann Surg.* 2002;236:612–8.
- Huxley R, Ansary-Moghaddam A, Berrington de Gonzalez A, Barzi F, Woodward M. Type-II diabetes and pancreatic cancer: a meta-analysis of 36 studies. *Br J Cancer.* 2005;92:2076–83.
- Ibars EP, Sanchez de Rojas EA, Quereda LA, Ramis RF, Sanjuan VM, Peris RT. Pancreatic function after acute biliary pancreatitis: does it change? *World J Surg.* 2002;26:479–86.



- Isaksson B, Strommer L, Friess H, Buchler MW, Herrington MK, Wang F, Zierath JR, Wallberg-Henriksson H, Larsson J, Permert J. Impaired insulin action on phosphatidylinositol 3-kinase activity and glucose transport in skeletal muscle of pancreatic cancer patients. *Pancreas*. 2003;26:173–7.
- Jaster R. Molecular regulation of pancreatic stellate cell function. *Mol Cancer*. 2004;3:26.
- Joffe BI, Bank S, Jackson WP, Keller P, O'Reilly IG, Vinik AI. Insulin reserve in patients with chronic pancreatitis. *Lancet*. 1968;2:890–2.
- Jouihan HA, Cobine PA, Cooksey RC, Hoagland EA, Boudina S, Abel ED, Winge DR, McClain DA. Iron-mediated inhibition of mitochondrial manganese uptake mediates mitochondrial dysfunction in a mouse model of hemochromatosis. *Mol Med*. 2008;14:98–108.
- Kalk WJ, Vinik AI, Bank S, Keller P, Jackson WP. Selective loss of beta cell response to glucose in chronic pancreatitis. *Horm Metab Res*. 1974;6:95–8.
- Kannan V, Nabarro JD, Cotton PB. Glucagon secretion in chronic pancreatitis. *Horm Res*. 1979;11:203–12.
- Katsumichi I, Pour PM. Diabetes mellitus in pancreatic cancer: is it a causal relationship? *Am J Surg*. 2007;194:S71–5.
- Kendall DM, Sutherland DE, Najarian JS, Goetz FC, Robertson RP. Effects of hemipancreatectomy on insulin secretion and glucose tolerance in healthy humans. *N Engl J Med*. 1990;322:898–903.
- King J, Kazanjian K, Matsumoto J, Reber HA, Yeh MW, Hines OJ, Eibl G. Distal pancreatectomy: incidence of postoperative diabetes. *J Gastrointest Surg*. 2008;12:1548–53.
- Koch C, Cuppens H, Rainisio M, Madessani U, Harms H, Hodson M, Mastella G, Navarro J, Strandvik B, McKenzie S, Investigators of the ERF. European Epidemiologic Registry of Cystic Fibrosis (ERCF): comparison of major disease manifestations between patients with different classes of mutations. *Pediatr Pulmonol*. 2001;31:1–12.
- Koizumi M, Yoshida Y, Abe N, Shimosegawa T, Toyota T. Pancreatic diabetes in Japan. *Pancreas*. 1998;16:385–91.
- Kopelman H, Corey M, Gaskin K, Durie P, Weizman Z, Forstner G. Impaired chloride secretion, as well as bicarbonate secretion, underlies the fluid secretory defect in the cystic fibrosis pancreas. *Gastroenterology*. 1988;95:349–55.
- Kuo P, Stevens JE, Russo A, Maddox A, Wishart JM, Jones KL, Greville H, Hetzel D, Chapman I, Horowitz M, Rayner CK. Gastric emptying, incretin hormone secretion, and postprandial glycemia in cystic fibrosis – effects of pancreatic enzyme supplementation. *J Clin Endocrinol Metab*. 2011;96:E851–5.
- Larsen S, Hilsted J, Tronier B, Worning H. Metabolic control and B cell function in patients with insulin-dependent diabetes mellitus secondary to chronic pancreatitis. *Metabolism*. 1987;36:964–7.
- Larsen S, Hilsted J, Tronier B, Worning H. Pancreatic hormone secretion in chronic pancreatitis without residual beta-cell function. *Acta Endocrinol*. 1988;118:357–64.
- Leahy JL, Bumbalo LM, Chen C. Diazoxide causes recovery of beta-cell glucose responsiveness in 90% pancreatectomized diabetic rats. *Diabetes*. 1994;43:173–9.
- Li D. Diabetes and pancreatic cancer. *Mol Carcinog*. 2012;51:64–74.
- Linde J, Nilsson LH, Barany FR. Diabetes and hypoglycemia in chronic pancreatitis. *Scand J Gastroenterol*. 1977;12:369–73.
- Liu J, Kazakoff K, Pour PM, Adrian TE. The intracellular mechanism of insulin resistance in the hamster pancreatic ductal adenocarcinoma model. *Pancreas*. 1998;17:359–66.
- Liu YQ, Nevin PW, Leahy JL. Beta-cell adaptation in 60% pancreatectomy rats that preserves normoinsulinemia and normoglycemia. *Am J Physiol Endocrinol Metab*. 2000;279:E68–73.
- Massucco P, Calgario M, Bertolino F, Bima C, Galatola G, Capussotti L. Outcome of surgical treatment for chronic calcifying pancreatitis. *Pancreas*. 2001;22:378–82.
- Matveyenko AV, Veldhuis JD, Butler PC. Mechanisms of impaired fasting glucose and glucose intolerance induced by an approximate 50% pancreatectomy. *Diabetes*. 2006;55:2347–56.

- McClain DA, Abraham D, Rogers J, Brady R, Gault P, Ajioka R, Kushner JP. High prevalence of abnormal glucose homeostasis secondary to decreased insulin secretion in individuals with hereditary haemochromatosis. *Diabetologia*. 2006;49:1661–9.
- McCulloch DK, Koerker DJ, Kahn SE, Bonner-Weir S, Palmer JP. Correlations of in vivo beta-cell function tests with beta-cell mass and pancreatic insulin content in streptozocin-administered baboons. *Diabetes*. 1991;40:673–9.
- Mendler MH, Turlin B, Moirand R, Jouanolle AM, Sapey T, Guyader D, Le Gall JY, Brissot P, David V, Deugnier Y. Insulin resistance-associated hepatic iron overload. *Gastroenterology*. 1999;117:1155–63.
- Merkel PA, Simonson DC, Amiel SA, Plewe G, Sherwin RS, Pearson HA, Tamborlane WV. Insulin resistance and hyperinsulinemia in patients with thalassemia major treated by hypertransfusion. *N Engl J Med*. 1988;318:809–14.
- Messina MF, Lombardo F, Meo A, Miceli M, Wasniewska M, Valenzise M, Ruggeri C, Arrigo T, De Luca F. Three-year prospective evaluation of glucose tolerance, beta-cell function and peripheral insulin sensitivity in non-diabetic patients with thalassemia major. *J Endocrinol Invest*. 2002;25:497–501.
- Mezza T, Clemente G, Sorice GP, Conte C, De Rose AM, Sun VA, Cefalo CM, Pontecorvi A, Nuzzo G, Giaccari A. Metabolic consequences of the occlusion of the main pancreatic duct with acrylic glue after pancreaticoduodenectomy. *Am J Surg*. 2015;210:783–9.
- Mohan K, Israel KL, Miller H, Grainger R, Ledson MJ, Walshaw MJ. Long-term effect of insulin treatment in cystic fibrosis-related diabetes. *Respiration*. 2008;76:181–6.
- Moirand R, Adams PC, Bicheler V, Brissot P, Deugnier Y. Clinical features of genetic hemochromatosis in women compared with men. *Ann Intern Med*. 1997;127:105–10.
- Moran A, Hardin D, Rodman D, Allen HF, Beall RJ, Borowitz D, Brunzell C, Campbell PW 3rd, Chesrown SE, Duchow C, Fink RJ, Fitzsimmons SC, Hamilton N, Hirsch I, Howenstine MS, Klein DJ, Madhun Z, Pencharz PB, Quittner AL, Robbins MK, Schindler T, Schissel K, Schwarzenberg SJ, Stallings VA, Zipf WB, et al. Diagnosis, screening and management of cystic fibrosis related diabetes mellitus: a consensus conference report. *Diabetes Res Clin Pract*. 1999;45:61–73.
- Moriai T, Morita Y, Matsui T, Okada M. Type 1 diabetes mellitus associated with clinical acute pancreatitis in an adult. *Pancreas*. 2000;20:415–6.
- Nakamori S, Ishikawa O, Ohigashi H, Sasakuma F, Shimizu T, Nakaizumi A, Furukawa H, Sasaki Y, Imaoka S. Increased blood proinsulin and decreased C-peptide levels in patients with pancreatic cancer. *Hepatogastroenterology*. 1999;46:16–24.
- Nathan DM, Buse JB, Davidson MB, Ferrannini E, Holman RR, Sherwin R, Zinman B, American Diabetes Association, European Association for Study of Diabetes. Medical management of hyperglycemia in type 2 diabetes: a consensus algorithm for the initiation and adjustment of therapy: a consensus statement of the American Diabetes Association and the European Association for the Study of Diabetes. *Diabetes Care*. 2009;32:193–203.
- Noel RA, Braun DK, Patterson RE, Bloomgren GL. Increased risk of acute pancreatitis and biliary disease observed in patients with type 2 diabetes: a retrospective cohort study. *Diabetes Care*. 2009;32:834–8.
- Nosadini R, del Prato S, Tiengo A, Duner E, Toffolo G, Cobelli C, Faronato PP, Moghetti P, Muggeo M. Insulin sensitivity, binding, and kinetics in pancreatogenic and type I diabetes. *Diabetes*. 1982;31:346–55.
- Nyboe Andersen B, Krarup T, Thorsgaard Pedersen NT, Faber OK, Hagen C, Worning H. B cell function in patients with chronic pancreatitis and its relation to exocrine pancreatic function. *Diabetologia*. 1982;23:86–9.
- Ogunleye AA, Ogston SA, Morris AD, Evans JM. A cohort study of the risk of cancer associated with type 2 diabetes. *Br J Cancer*. 2009;101:1199–201.
- Ohneda A, Kai Y, Ishii S, Matsuda K, Horigome K. Insulin and glucagon response in patients with chronic pancreatitis. *Tohoku J Exp Med*. 1976;120:287–98.

- Omary MB, Lugea A, Lowe AW, Pandol SJ. The pancreatic stellate cell: a star on the rise in pancreatic diseases. *J Clin Invest.* 2007;117:50–9.
- Paye F. The pancreatic stump after pancreatoduodenectomy: the “Achille’s heel” revisited. *J Visc Surg.* 2010;147:e13–20.
- Permert J, Ihse I, Jorfeldt L, von Schenck H, Arnqvist HJ, Larsson J. Pancreatic cancer is associated with impaired glucose metabolism. *Eur J Surg.* 1993a;159:101–7.
- Permert J, Adrian TE, Jacobsson P, Jorfelt L, Fruin AB, Larsson J. Is profound peripheral insulin resistance in patients with pancreatic cancer caused by a tumor-associated factor? *Am J Surg.* 1993b;165:61–6; discussion 66–7.
- Permert J, Larsson J, Westermark GT, Herrington MK, Christmanson L, Pour PM, Westermark P, Adrian TE. Islet amyloid polypeptide in patients with pancreatic cancer and diabetes. *N Engl J Med.* 1994;330:313–8.
- Permert J, Larsson J, Fruin AB, Tatemoto K, Herrington MK, von Schenck H, Adrian TE. Islet hormone secretion in pancreatic cancer patients with diabetes. *Pancreas.* 1997;15:60–8.
- Phillips JM, O’Reilly L, Bland C, Foulis AK, Cooke A. Patients with chronic pancreatitis have islet progenitor cells in their ducts, but reversal of overt diabetes in NOD mice by anti-CD3 shows no evidence for islet regeneration. *Diabetes.* 2007;56:634–40.
- Pietrangelo A. Hereditary hemochromatosis: pathogenesis, diagnosis, and treatment. *Gastroenterology.* 2010;139:393–408, 408.e391–2.
- Pour PM, Permert J, Mogaki M, Fujii H, Kazakoff K. Endocrine aspects of exocrine cancer of the pancreas. Their patterns and suggested biologic significance. *Am J Clin Pathol.* 1993;100:223–30.
- Rickels MR, Bellin M, Toledo FG, Robertson RP, Andersen DK, Chari ST, Brand R, Frulloni L, Anderson MA, Whitcomb DC, PancreasFest Recommendation Conference Participants. Detection, evaluation and treatment of diabetes mellitus in chronic pancreatitis: recommendations from PancreasFest 2012. *Pancreatol.* 2013;13:336–42.
- Sadeghi N, Abbruzzese JL, Yeung SC, Hassan M, Li D. Metformin use is associated with better survival of diabetic patients with pancreatic cancer. *Clin Cancer Res.* 2012;18:2905–12.
- Saruc M, Pour PM. Diabetes and its relationship to pancreatic carcinoma. *Pancreas.* 2003;26:381–7.
- Schneider MU, Knoll-Ruzicka ML, Domschke S, Heptner G, Domschke W. Pancreatic enzyme replacement therapy: comparative effects of conventional and enteric-coated microspheric pancreatin and acid-stable fungal enzyme preparations on steatorrhea in chronic pancreatitis. *Hepatogastroenterology.* 1985;32:97–102.
- Schneider L, Hartwig W, Flemming T, Hackert T, Fortunato F, Heck M, Gebhard MM, Nawroth PP, Bierhaus A, Buchler MW, Werner J. Protective effects and anti-inflammatory pathways of exogenous calcitonin gene-related peptide in severe necrotizing pancreatitis. *Pancreatol.* 2009;9:662–9.
- Schwartz SS, Zeidler A, Moossa AR, Kuku SF, Rubenstein AH. A prospective study of glucose tolerance, insulin, C-peptide, and glucagon responses in patients with pancreatic carcinoma. *Am J Dig Dis.* 1978;23:1107–14.
- Sikkens EC, Cahen DL, Koch AD, Braat H, Poley JW, Kuipers EJ, Bruno MJ. The prevalence of fat-soluble vitamin deficiencies and a decreased bone mass in patients with chronic pancreatitis. *Pancreatol.* 2013;13:238–42.
- Simcox JA, McClain DA. Iron and diabetes risk. *Cell Metab.* 2013;17:329–41.
- Slezak LA, Andersen DK. Pancreatic resection: effects on glucose metabolism. *World J Surg.* 2001;25:452–60.
- Sparmann G, Hohenadl C, Tornøe J, Jaster R, Fitzner B, Koczan D, Thiesen HJ, Glass A, Winder D, Liebe S, Emmrich J. Generation and characterization of immortalized rat pancreatic stellate cells. *Am J Physiol Gastrointest Liver Physiol.* 2004;287:G211–9.
- Suc B, Msika S, Fingerhut A, Fourtanier G, Hay JM, Holmieres F, Sastre B, Fagniez PL, French Associations for Surgical Research. Temporary fibrin glue occlusion of the main pancreatic duct in the prevention of intra-abdominal complications after pancreatic resection: prospective randomized trial. *Ann Surg.* 2003;237:57–65.

- van den Berg JM, Morton AM, Kok SW, Pijl H, Conway SP, Heijerman HG. Microvascular complications in patients with cystic fibrosis-related diabetes (CFRD). *J Cyst Fibros.* 2008; 7:515–9.
- Vogiatzi MG, Macklin EA, Trachtenberg FL, Fung EB, Cheung AM, Vichinsky E, Olivieri N, Kirby M, Kwiatkowski JL, Cunningham M, Holm IA, Fleisher M, Grady RW, Peterson CM, Giardina PJ, Thalassaemia Clinical Research Network. Differences in the prevalence of growth, endocrine and vitamin D abnormalities among the various thalassaemia syndromes in North America. *Br J Haematol.* 2009;146:546–56.
- Wang F, Larsson J, Abdiu A, Gasslander T, Westermark P, Adrian TE, Permert J. Dissociated secretion of islet amyloid polypeptide and insulin in serum-free culture media conditioned by human pancreatic adenocarcinoma cell lines. *Int J Pancreatol.* 1997;21:157–64.
- Wang F, Adrian TE, Westermark G, Gasslander T, Permert J. Dissociated insulin and islet amyloid polypeptide secretion from isolated rat pancreatic islets cocultured with human pancreatic adenocarcinoma cells. *Pancreas.* 1999;18:403–9.
- Wang F, Herrington M, Larsson J, Permert J. The relationship between diabetes and pancreatic cancer. *Mol Cancer.* 2003;2:4.
- Wang X, Misawa R, Zielinski MC, Cowen P, Jo J, Periwal V, Ricordi C, Khan A, Szust J, Shen J, Millis JM, Witkowski P, Hara M. Regional differences in islet distribution in the human pancreas – preferential beta-cell loss in the head region in patients with type 2 diabetes. *PLoS One.* 2013;8:e67454.
- Weatherall DJ. Pathophysiology of thalassaemia. *Baillieres Clin Haematol.* 1998;11:127–46.
- Yki-Jarvinen H, Kiviluoto T, Taskinen MR. Insulin resistance is a prominent feature of patients with pancreatogenic diabetes. *Metabolism.* 1986;35:718–27.



# Impact of Drugs on Diabetes Risk and Glycemic Control

# 18

Simona Frontoni and Fabiana Picconi

## Contents

Introduction .....	542
Glucocorticoids and Other Hormones .....	543
Insulin Resistance .....	545
Liver .....	545
Skeletal Muscle .....	546
Adipose Tissue .....	546
Insulin Secretion .....	547
Oral Contraceptives .....	548
Growth Hormone .....	548
Somatostatin Analogues .....	549
Antihypertensives .....	550
Thiazide Diuretics .....	550
Beta-Blocking Agents .....	552
CCBs .....	553
Lipid-Modifying Agents .....	554
Statins .....	554
Nicotinic Acid .....	557
Antiarrhythmics .....	557
Anti-infectives .....	558
Antibiotics .....	558
Antimycobacterials .....	558
Antivirals .....	559
Antiprotozoals .....	560
Drugs Affecting the Nervous System .....	560
Antiepileptics .....	560
Antipsychotic Drugs .....	560
Antidepressant Drugs .....	562
Antineoplastic Agents .....	562

S. Frontoni (✉) · F. Picconi

Department of Systems Medicine; Unit of Endocrinology, Diabetes and Metabolism, S. Giovanni Calibita Fatebenefratelli Hospital, University of Rome Tor Vergata, Rome, Italy

e-mail: [frontoni@uniroma2.it](mailto:frontoni@uniroma2.it); [fabipicco@gmail.com](mailto:fabipicco@gmail.com)

---

Immunosuppressive Agents .....	563
Summary .....	564
References .....	564

---

### Abstract

A variety of pharmacological agents affect glucose homeostasis resulting in hyperglycemia, thus predisposing to or precipitating diabetes, when pre-existing risk factors are present. Drug-induced hyperglycemia is often benign and reversible within days with some drugs but may take longer if it is secondary to weight gain or peripheral insulin resistance. Drug-induced hyperglycemia can also implicate an increased risk of microvascular and macrovascular complications, infections, metabolic coma, and even death.

Patients showing factors predisposing to the development of diabetes mellitus (sedentary lifestyle, overweight or obesity, impaired fasting glucose or glucose intolerance, family history of diabetes, history of vascular disease, gestational diabetes, or at least one risk factor for metabolic syndrome) are at particular risk of drug-induced hyperglycemia, as some drugs can worsen pre-existing insulin resistance or pancreatic dysfunction. Thus, these risk factors should be considered before initiating drugs with potentially disturbing effects on glycemic control; moreover, efforts should be made to identify and closely monitor patients receiving drugs that are known to induce hyperglycemia. Possible mechanisms of drug-induced hyperglycemia include alterations of insulin secretion and sensitivity, direct cytotoxic effects on pancreatic cells, and increase in glucose production. Several potential strategies may be used to counteract hyperglycemia, first of all lifestyle intervention, but also a dose reduction, particularly for agents that exhibit a dose-dependent effect on glycemia. However, the discontinuation of the incriminated drug, when possible, is the best option to reverse drug-induced hyperglycemia. The time needed to improve or return to baseline glycemia generally depends on the offending drug.

---

### Keywords

Drug-related diabetes

---

## Introduction

This chapter reviews the latest data concerning hyperglycemia and diabetes secondary to drugs. A description of the main pathophysiologic mechanisms, where available, is presented.

The main mechanisms and drugs implicated in drug-induced hyperglycemia are summarized in Table 1 (Fathallah et al. 2015).

**Table 1** Mechanisms of drug-induced hyperglycemia. (Modified from Fathallah et al. 2015)

<b>Diminution of insulin secretion and/or insulin production</b>
Beta antagonists <sup>a</sup> (effects are attenuated but not abolished with cardioselective drugs)
Calcium channel antagonists (related to calcium channel blockade)
Phenytoin
Pentamidine
L-asparaginase
Immunosuppressive drugs (tacrolimus, cyclosporine)
Diuretics (related to hypokalemia) <sup>a</sup>
Antiarrhythmics <sup>a</sup>
<b>Diminution of peripheral insulin sensitivity and/or promotion of weight gain</b>
Atypical antipsychotics
Antidepressant drugs
Glucocorticoids
Beta agonists
Oral contraceptives
Protease inhibitors
Growth hormone
Nicotinic acid <sup>a</sup>
Nucleoside reverse transcriptase inhibitors (except for didanosine)
Diuretics <sup>a</sup>
Statins <sup>a</sup>
Interferons <sup>a</sup>
<b>Increase in glucose production through promotion of hepatic gluconeogenesis and/or glycogenolysis</b>
Glucocorticoids <sup>a</sup>
Nicotinic acid <sup>a</sup>
Beta agonists <sup>a</sup>
Diuretics <sup>a</sup>
Beta antagonists <sup>a</sup>
<b>Destruction of pancreatic cells, leading to beta-cell injury</b>
Didanosine
Interferons <sup>a</sup>
Pentamidine <sup>a</sup>
Statins <sup>a</sup>
Glucocorticoids <sup>a</sup>

<sup>a</sup>More than one mechanism is proposed

## Glucocorticoids and Other Hormones

Glucocorticoids (GCs) are frequently prescribed anti-inflammatory and immunosuppressive drugs. In addition to their beneficial effects on disease activity, GCs have an extensive side effect profile, including adverse effects on metabolism resulting in the development of glucose intolerance and overt diabetes.

The GC-associated risk of developing diabetes is difficult to estimate for several reasons: first, different GC formulations, during differing time periods and at different dosing regimens. Second, an increase susceptibility of developing

hyperglycemia in part due to the varying indications for GC treatment, different age groups, comorbidities, and genetic factors. Finally, most studies measured only fasting glucose levels, with a consequent underestimation of diabetes diagnosis. In a study population, with 644,495 registered patients, a 36% increased diabetes risk was reported with oral glucocorticoid prescriptions. Minimal or no association of diabetes with glucocorticoid-containing topical preparations, eye drops, or infrequent glucocorticoid injections for musculoskeletal disorders was described (Gulliford et al. 2006). However, in an older population (aged >65 years), a higher risk was observed (Blackburn et al. 2002).

The risk of GC-induced diabetes is even higher in selected populations. In particular, 10–20% of subjects treated with glucocorticoids for solid organ transplant develop diabetes, most of them within the first months of administration (Boudreaux et al. 1987; Depczynski et al. 2000; Friedman et al. 1985). Nearly 24% of pregnant women exposed to glucocorticoids for preterm labor develop diabetes versus 4% of unexposed women (Fisher et al. 1997). In GC-treated rheumatoid arthritis patients (Hoes et al. 2011) and primary renal disease patients (Uzu et al. 2007), a diabetes prevalence ranging between 20% and 40% was reported, although in the non-GC-treated groups, diabetes prevalence was also high due to the impact of systemic inflammation on glucose metabolism.

The risk of diabetes increases with the duration of exposure and the daily dosage of glucocorticoids (Huscher et al. 2009). In patients using oral GCs, a dose-dependent increase in the risk to develop diabetes requiring anti-hyperglycemic therapy was described, with ORs of 1.36 (95% CI 1.10–1.69) for lower (defined as <10 mg prednisolone equivalent) and 5.82 (95% CI 2.74–12.35) for higher (defined as >25 mg prednisolone equivalent) GC dosages, respectively (Gurwitz et al. 1994). An increased risk is observed even in subjects exposed to a lower dosage of systemic GCs (i.e., <7.5 mg/day of prednisone equivalent) (Huscher et al. 2009; Burt et al. 2012). People exposed to inhaled GCs are also at higher risk of diabetes, with a 34% increase in the rate of diabetes onset (Suissa et al. 2010). Patient characteristics (e.g., older age, higher body mass index, African-American race) and a family history of diabetes can predispose to GC-induced diabetes (Kim et al. 2011). The risk may differ with the type and biochemical properties of the GC used (e.g., potency and duration of the anti-inflammatory effects), but only little differences are observed between the GCs most frequently used (i.e., prednisone, prednisolone, and methylprednisolone) (Fardet and Fève 2014).

The mechanisms underlying these so-called diabetogenic effects of GCs regarding glucose, lipid, and protein metabolism were mainly attributed to GC-induced insulin resistance at the level of the liver, skeletal muscle, and adipose tissue (Fain 1964; Issekutz Jr and Borkow 1973; Kaplan and Shimizu 1963; Lecocq et al. 1964).

The mechanisms by which GCs are thought to induce hyperglycemia are summarized in Fig. 1 (van Raalte and Diamant 2014).



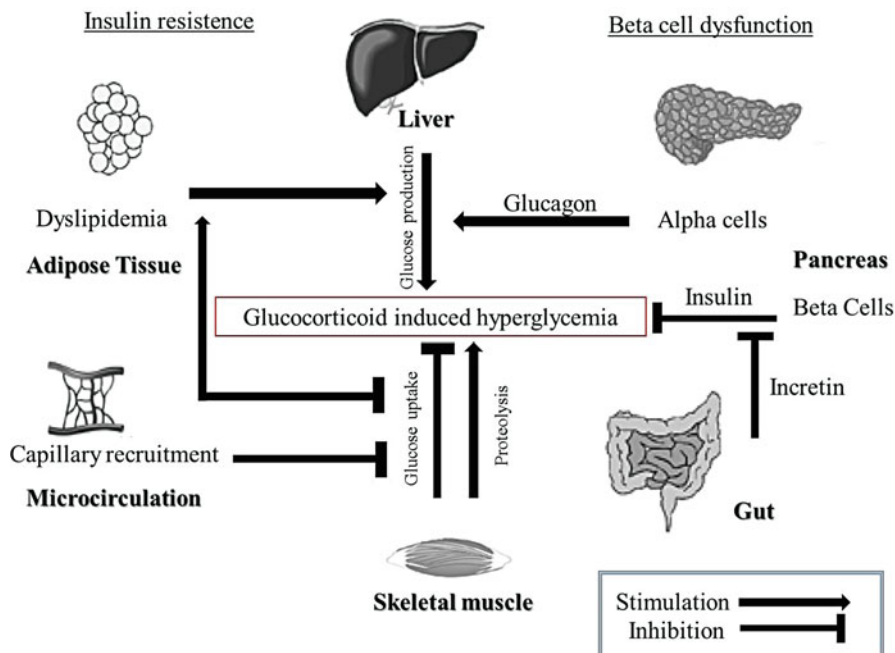

**Fig. 1** The mechanisms by which GC may induce hyperglycemia (modified from van Raalte and Diamant 2014)

## Insulin Resistance

### Liver

In healthy volunteers, pharmacological dosages of GCs administered in the short term increased endogenous glucose production in the fasted state in a number (Rizza et al. 1982; Rooney et al. 1993; Wajngot et al. 1992; van Raalte et al. 2011a) but not in all studies (Wajngot et al. 1992; Nielsen et al. 2004; Miyoshi et al. 1988; Schneider and Tappy 1998). This increase in endogenous glucose production is dependent by increment in gluconeogenesis rather than glycogenolysis (Bollen et al. 1998), through an increased expression and activity of key enzymes, including phosphoenolpyruvate carboxykinase (PEPCK) (Jin et al. 2004) and glucose-6-phosphatase. PEPCK gene is, indeed, considered a key player in GC-induced hyperglycemia because it contains a glucocorticoid response element in its promoter region (Vegiopoulos and Herzig 2007). Other mechanisms include an increased delivery of substrate for gluconeogenesis to the liver, through the breakdown of peripheral protein and fat stores (Kraus-Friedmann 1984) and strengthening of the other counter-regulatory hormone effects, such as glucagon and epinephrine (Dirlewanger et al. 2000). During hyperinsulinemic conditions, both acute and more prolonged

GC treatments were shown to reduce the suppressive effects of insulin on endogenous glucose production by up to 50% (Rizza et al. 1982; Rooney et al. 1993; van Raalte et al. 2011a). The mechanisms underlying this GC-induced liver insulin resistance are currently not clarified. In rats, dexamethasone was shown to impair the insulin-signaling cascade, leading to reduced activation of insulin receptor substrate-1 and phosphatidylinositol 3-kinase in liver cells (Saad et al. 1993). Of note, GCs also affect hepatic lipid metabolism by increasing very-low-density lipoprotein production and stimulating de novo lipogenesis (Macfarlane et al. 2008).

## Skeletal Muscle

At skeletal muscle level, GCs particularly impair non-oxidative glucose disposal (reflecting glycogen synthesis), with no apparent effect on glucose oxidation rates (van Raalte et al. 2011a; Henriksen et al. 1999).

In particular, dexamethasone treatment has been shown to reduce insulin-stimulated glucose uptake, glycogen synthesis, glycogen synthase fractional activity, and dephosphorylation. These defects were paralleled by reduced insulin-stimulated protein kinase B (PKB) and glycogen synthase-3 (GSK-3) inhibitor phosphorylation (Ruzzin et al. 2005). GCs increase plasma levels of nonesterified fatty acids (NEFA) by impairing the insulin-mediated suppression of adipose tissue lipolysis (van Raalte et al. 2011a) and increase plasma levels of amino acids due to enhanced proteolysis (Lofberg et al. 2002; Short et al. 2009), resulting in a strong inhibition of insulin-stimulated glucose uptake (Krebs et al. 2002; Perseghin et al. 2003). GC may also impair glucose uptake by altering the insulin-induced recruitment of capillaries in skeletal muscle tissue. A short-term treatment with low-dose (7.5 mg daily) and high-dose (30 mg daily) prednisolone dose-dependently impaired insulin-stimulated capillary recruitment in healthy subjects, as assessed by capillary microscopy (van Raalte et al. 2013a). Finally, GCs induce total skeletal muscle mass atrophy (Khaleeli et al. 1983), therefore reducing insulin-mediated glucose uptake.

## Adipose Tissue

GCs change adipose tissue distribution, increasing visceral adipose tissue with consequent reduction of subcutaneous adipose tissue (Ibrahim 2010). In addition, GC may also affect adipose tissue function, acutely increasing fasting lipolysis rates in vitro and in vivo (Macfarlane et al. 2008), by activation of the key lipolytic enzymes adipose triglyceride lipase (ATGL) and hormone-sensitive lipase (HSL) and possibly by augmented beta-adrenergic signaling (Peckett et al. 2011), resulting in increased plasma NEFA levels. GCs have also been shown to alter levels of various adipocytokines both in vitro and in vivo toward a more diabetogenic profile

(Fasshauer and Paschke 2003). In particular, resistin and leptin levels, negatively associated with insulin sensitivity, were both increased by high-dose prednisolone treatment (Ouchi et al. 2011).

In analogy to the liver and skeletal muscle, GCs were shown to impair insulin signaling through a downregulation of insulin receptor substrate-1, in 3T3-L1 adipocytes *in vitro* and in human adipose tissue *in vivo* (Turnbow et al. 1994).

---

## Insulin Secretion

*In vitro* studies have clearly shown an impairment of insulin secretion, impaired insulin biosynthesis, and beta-cell apoptosis in insulinoma cell lines and in rodent-derived islets, by GC (Ranta et al. 2006). Short-term high-dose prednisolone administration impaired first-phase glucose-stimulated insulin secretion as well as insulin secretion induced by the arginine stimulation, as measured by a hyperglycemic clamp study (van Raalte et al. 2011b). At the same GC dose, a reduction in beta-cell glucose sensitivity demonstrated by the impairment of beta-cell function during a standardized meal test was also observed (van Raalte et al. 2010).

More prolonged administration of GC to healthy volunteers has shown an increase of fasting insulin levels and insulin secretion following oral or intravenous stimulation tests, as a compensation for GC-induced insulin resistance (van Raalte et al. 2010; Hansen et al. 2010, 2012).

Prednisolone also reduces maximal insulin secretory capacity, in response to arginine (van Raalte et al. 2013b), and impairs insulin secretion induced by the incretin hormones (Hansen et al. 2012).

In the 1970s, the effect of GC on alpha cells of increased glucagon levels was already described. In healthy individuals treated with dexamethasone and in patients with Cushing's syndrome, fasting glucagon levels were increased, and glucagon concentrations were incompletely suppressed following ingestion of a protein meal or following alanine infusion (Wise et al. 1973). The effects of GCs on glucagon levels are dose-dependent: only high-dose (30 mg prednisolone daily) but not low-dose (7.5 mg prednisolone daily) GC treatment increased fasting and postprandial glucagon levels following a 2-week treatment in healthy men (van Raalte et al. 2011a, 2013a, b). This effect of high-dose GCs on glucagon levels was already evident after a single dose (van Raalte et al. 2011b). Thus, both fasting and postprandial hyperglucagonemia are present in GC-induced hyperglycemia.

Only recently, the effects of GC treatment on glucagon-like peptide-1 (GLP-1) secretion and its insulinotropic actions have been addressed. In rodents, GC treatment resulted in decreased mRNA stability of the pre-proglucagon gene, a precursor of GLP-1, resulting in reduced GLP-1 levels (Zhang et al. 2009).

On the other hand, in healthy volunteers, treatment with prednisolone did not affect circulating GLP-1 concentrations during standardized meal tests (van Raalte

et al. 2013b; Hansen et al. 2011), but steroid treatment impaired the incretin effect, measured using a 75 g oral glucose tolerance test (OGTT) and iso-glycemic intravenous glucose infusion (Hansen et al. 2010).

It is unclear whether the impaired incretin effect is a specific beta-cell defect induced by GC treatment or whether it may be secondary to general GC-induced beta-cell dysfunction. Thus, an impaired gut-islet axis characterized by impaired insulinotropic effects of GLP-1 is present in GC-induced hyperglycemia (van Raalte and Diamant 2014).

In conclusion, in patients on long-term GC treatment and even in patients on transient GC treatment, plasma glucose should be monitored at regular intervals, in order to plan an early and effective approach to GC-induced hyperglycemia. This should include, together with lifestyle measures, insulin sensitizer drugs or insulin therapy, when needed.

## Oral Contraceptives

Modern oral combined contraceptives (OC), which contain low doses of estrogen, do not impact glucose metabolism (Crook and Godsland 1998).

However, estrogen and high doses of combined estrogen-progestin display a negative effect on carbohydrate metabolism, mainly due to estrogen-induced increase in serum triglyceride and progestin-induced increase in serum low-density-level cholesterol (LDL-C) and decrease in high-density-level cholesterol (HDL-C) (Friedrich et al. 2012).

Data from the literature are quite inconclusive, some reporting no major differences in carbohydrate metabolism between different hormonal contraceptives and some others showing OC-induced metabolic disorders, particularly in overweight/obese women. These discrepancies are largely due to heterogeneity of the studies, small numbers of participants and elevated dropout, and limited reporting of methods.

In conclusion, women receiving OC treatment should be regularly monitored for serum lipid levels and glycemia, especially when showing risk factors for metabolic syndrome (Lopez et al. 2014).

## Growth Hormone

Due to its known lipolytic and contra-insular effect, growth hormone (GH) can induce insulin resistance (Garg 1994); particularly, long-term GH therapy has been shown to induce hyperglycemia by inhibition of insulin-stimulated glucose uptake in skeletal muscle (Reed et al. 2013).

As for other drug-induced conditions of hyperglycemia, high-risk patients are more likely to develop glucose intolerance (Hoffman et al. 2004), while insulin resistance and hyperglycemia in children are generally milder and transient (Hwang 2014).

In addition, higher than recommended doses of GH have a worse impact on glucose metabolism, as expected (Johannsson et al. 1997).

## Somatostatin Analogues

Impaired glucose tolerance is often observed in acromegalic patients, and treatment with somatostatin analogues has variable effects on glycemic control. As a consequence, the net effect of somatostatin analogues on glucose metabolism is somewhat hard to define, as shown in one study aimed to compare the effects of lanreotide slow release (L-SR) versus octreotide long-acting release (O-LAR), in ten patients with acromegaly (two of whom with overt type 2 diabetes mellitus). Although both treatments were associated with a decrease in insulin resistance, fasting glucose, glucose response to oral glucose tolerance test (OGTT), and glycosylated hemoglobin (HbA1c) levels significantly increased after O-LAR, but not L-SR treatment (Ronchi et al. 2002). Moreover, the use of preoperative subcutaneous octreotide in an infant undergoing subtotal pancreatectomy for congenital hyperinsulinism was associated with severe paradoxical hyperglycemia and bradycardia (Batra et al. 2007).

Pasireotide, recently approved for the treatment of acromegaly and Cushing disease, has been associated with hyperglycemia, in most clinical trials. Particularly, in the pasireotide versus continued treatment with octreotide or lanreotide in Patients with Inadequately Controlled Acromegaly (PAOLA) study (Gadelha et al. 2014), aimed to compare the efficacy and safety of two different doses of pasireotide long-acting release with active control (octreotide or lanreotide), hyperglycemia was more common (~30%) versus active control (14%) as well as diabetes mellitus (~25% vs. 9%, respectively). Five patients discontinued pasireotide LAR treatment because of serious adverse events, all of which were related to pasireotide-induced hyperglycemia or diabetes. Glycated hemoglobin (HbA1c) levels, which increased in the first 3 months of pasireotide LAR treatment, were stable by month 26.

Expert recommendations for treatment of pasireotide-associated hyperglycemia have recently been published, and new studies are planned to elucidate the optimal treatment approach for pasireotide-associated hyperglycemia (Samson 2014). The exact mechanism of pasireotide-induced hyperglycemia in patients with acromegaly is unknown. Data from a dose-response study in healthy volunteers suggested that pasireotide-associated hyperglycemia was due to insulin suppression. Also, mild inhibition of glucagon was reported. Further clinical research using a hyperglycemic clamp test in healthy volunteers showed that hyperglycemia associated with pasireotide treatment was not due to changes in hepatic/peripheral insulin sensitivity. Decreased gastrointestinal incretin hormones with the subsequent reduction on insulin secretion would seem to explain the increment in glucose levels. During an OGTT, GLP-1 and glucose-dependent insulinotropic polypeptide were significantly decreased compared with baseline. Careful monitoring of glycemic status is required

prior to and during pasireotide treatment, and antidiabetic therapy should be indicated whenever possible (Samson 2014).

---

## Antihypertensives

In the past, antihypertensive treatment, particularly with thiazide diuretics and beta-blockers, was considered to have a negative impact on glucose metabolism. Newer antihypertensive drugs, particularly renin-angiotensin system inhibitors on the contrary, have been shown to be metabolically neutral or even favorable. These considerations deeply influence the criteria of choice, especially for individuals with diabetes or at high risk for diabetes, also considering that it has been suggested that hyperglycemia occurring during antihypertensive therapy is a major cardiovascular risk factor (Dunder et al. 2003; Verdecchia et al. 2004).

Since not all antihypertensive drugs are equally implicated in worsening glucose metabolism, the choice of a drug able to lower glucose levels or prevent diabetes mellitus from occurring should be considered ideal. Glycemic adverse events occur more frequently with thiazide diuretics and with certain beta-blocking agents than with calcium channel blockers (CCBs) (Dahlöf et al. 2002), whereas inhibitors of the renin-angiotensin system, such as angiotensin-converting enzyme (ACE) inhibitors and angiotensin receptor blockers (ARB), have been reported to be associated with a reduced risk of type 2 diabetes and metabolic risk in comparison with placebo and other antihypertensive treatments (Jandeleit-Dahm et al. 2005). ACEI and ARB therapy seems to improve glycemia, through an upregulation of bradykinin and nitric oxide, both of which promote increased skeletal muscle and pancreatic blood flow. These drug classes are also reported to prevent the angiotensin II-mediated oxidative stress in the beta cell (Muscogiuri et al. 2008; Scheen 2004).

These data have been recently confirmed also in women with hypertension and coronary artery disease: ACE inhibitors, ARB, and alpha-blockers were associated with the lowest risk of new-onset diabetes, while the use of diuretics, beta-blockers, and CCBs was related with a significantly increased risk of developing new-onset diabetes during a 6-year follow-up (Liou et al. 2015).

In a recent randomized clinical trial, aimed at developing a predictive model for glucose change in hypertensive participants treated with atenolol or hydrochlorothiazide, baseline glucose was the best predictor of glucose increase and of the development of impaired fasting glucose (IFG), following treatment with either drug (Moore et al. 2014).

## Thiazide Diuretics

Elevated blood glucose levels have been reported during treatment of hypertension with thiazide diuretics for more than 50 years (Anonymous 1981). Side effects on glucose homeostasis have been described even at low doses of thiazides (Savage et al. 1998; Brown et al. 2000; ALLHAT Officers and Coordinators for the ALLHAT

Collaborative Research Group & The Antihypertensive and Lipid-Lowering Treatment to Prevent Heart Attack Trial 2002). Indeed, new-onset diabetes in hypertensive patients was slightly more frequent in those receiving low-dose diuretic therapy (co-amiloride) than in those receiving long-acting nifedipine once daily (Brown et al. 2000). A meta-analysis of 17 clinical trials, analyzing the effect of all different classes of antihypertensive drugs on the incidence of diabetes mellitus, showed that beta-blockers and thiazide diuretics were associated with the highest risk (Elliott and Meyer 2007).

In the Antihypertensive and Lipid-Lowering Treatment to Prevent Heart Attack Trial (ALLHAT) (ALLHAT Officers and Coordinators for the ALLHAT Collaborative Research Group & The Antihypertensive and Lipid-Lowering Treatment to Prevent Heart Attack Trial 2002), the incidence of diabetes was significantly higher in the chlorthalidone group than in the groups of patients receiving amlodipine and lisinopril. However, in spite of the risk of incident diabetes and the lack of difference in the incidence of the primary outcome (fatal coronary heart disease and nonfatal myocardial ischemia), thiazide diuretics were superior in lowering the risk of heart failure, and cardiovascular disease secondary to hyperglycemia did not seem to increase. This may be due, at least in part, to the effective reduction in blood pressure achieved by diuretic therapy (Alderman 2008).

The exact mechanisms of how thiazide diuretics cause the development of hyperglycemia are not clearly established. However, one of the main mechanisms proposed seems to be related to a reduction in insulin secretion, secondary to diuretic-induced hypokalemia (ALLHAT Officers and Coordinators for the ALLHAT Collaborative Research Group & The Antihypertensive and Lipid-Lowering Treatment to Prevent Heart Attack Trial 2002; Hirst et al. 2015), as also suggested by the observation that substitution with potassium salts can prevent deterioration in glucose tolerance and may restore insulin sensitivity, similarly to drug withdrawal (Tourniaire et al. 1988). In a recent trial, the combination of amiloride with hydrochlorothiazide, at doses equipotent on blood pressure, prevented glucose intolerance and improved control of blood pressure compared with monotherapy with either drug. These findings support a first-line use of amiloride plus hydrochlorothiazide in hypertensive patients who need treatment with a diuretic, for the prevention of side effects on glucose homeostasis (Brown et al. 2016).

Furthermore, diuresis may lead to decreased blood volume and cardiac output, which can activate the sympathetic nervous system, leading to reduced blood flow to the skeletal muscle, ultimately causing peripheral insulin resistance (Shafi et al. 2008; Aksnes et al. 2006).

Other possible mechanisms involved in thiazide-induced hyperglycemia are elevated free fatty acid levels, which are known to decrease insulin secretion in response to glucose, reduction in insulin sensitivity, and enhanced hepatic glucose production and/or catecholamine secretion and action (Duarte and Cooper-DeHoff 2010; Ayvaz et al. 2002; Eriksson et al. 2008).

In addition, thiazide diuretics are postulated to downregulate peroxisome proliferator-activated receptor gamma, thereby decreasing insulin release in addition

to activating the renin-angiotensin-aldosterone system, thus resulting in elevated levels of aldosterone and resulting hyperglycemia (Carter et al. 2008; Tham et al. 2002).

The most practical approach for preventing thiazide-induced hyperglycemia is to start with the lowest thiazide dosage and optimize serum potassium concentrations. Sometimes, thiazides should be used in combination with potassium supplements or potassium-sparing drugs, such as amiloride. If ineffective, diuretics should be combined with another first-line antihypertensive drug rather than being given at an increased dosage.

## Beta-Blocking Agents

As with thiazide diuretics, beta-blocking agents have been reported to increase the risk of hyperglycemia and new-onset diabetes (Messerli et al. 2009). Moreover, a systematic review of randomized trials suggests that thiazide diuretics and non-selective beta-blockers increase fasting blood glucose and HbA1c concentrations also in patients with diabetes by moderate amounts (Hirst et al. 2015).

In the over 12,000 nondiabetic subjects, followed prospectively in the Atherosclerosis Risk In Communities (ARIC) study, beta-blocking agents were associated with an increased risk of diabetes, among hypertensive subjects (Gress et al. 2000). Moreover, the addition of atenolol to chlorthalidone increased the rate of new-onset diabetes by 40%, in a post hoc analysis of the Systolic Hypertension in the Elderly Program (SHEP) clinical trial (Kostis et al. 2005).

On the other hand, in spite of this risk, beta-blocking agents have been associated with a significant reduction in morbidity and mortality from cardiovascular events, and a recent reanalysis of data from the Nateglinide And Valsartan in Impaired Glucose Tolerance Outcomes Research (NAVIGATOR) trial showed that beta-blockers were not associated with new-onset diabetes (Shen et al. 2013).

The differences between cardioselective and nonselective beta-blocking agents in terms of glycemic effects have not been fully elucidated. Indeed, a meta-analysis including 94,492 patients reported an increase of 22% in the risk of new-onset diabetes in patients treated with non-cardioselective beta-blocking agents (Bangalore et al. 2007).

A greater inhibitory effect on insulin secretion seems to be associated most frequently with propranolol, a nonselective beta-blocking agent (Samuelsson et al. 1994). In a recent study, atenolol was also shown to contribute to new-onset diabetes and to worsen hyperglycemia in people with abdominal obesity. In this study, adverse metabolic effects, including the development of impaired fasting glucose, were apparent within 9 weeks of therapy initiation (Cooper-DeHoff et al. 2010).

However, beta-blocking agents with intrinsic sympathomimetic activity (betalol and pindolol) or alpha-blocking effects have been reported to have a reduced impact on insulin sensitivity, with neutral or slightly favorable effects on glycemic control. Indeed, carvedilol and nebivolol have shown a differentiation from the rest of the



class. In the Glycemic Effects in Diabetes Mellitus: Carvedilol-Metoprolol Comparison in Hypertensives (GEMINI) study (Bakris et al. 2004), HbA1c increased with metoprolol, but not carvedilol, while insulin sensitivity improved with carvedilol compared to metoprolol. Similarly, a study in subjects with metabolic syndrome comparing a 12-week therapy with nebivolol (5 mg/day) to metoprolol (100 mg/day) (Ayers et al. 2012) showed a similar decrease in blood pressure and heart rate, but a reduction of insulin sensitivity with metoprolol compared to nebivolol. In addition, nebivolol does not seem to be associated with hyperglycemia or new-onset diabetes (Jacob et al. 1996; Bakris et al. 2004; Rosei and Rizzoni 2007).

Several possible mechanisms may be responsible for the disadvantageous effects of beta-blockers on glucose metabolism. First of all, treatment with conventional beta-blockers leads to an unopposed  $\alpha 1$ -activity which causes vasoconstriction and decreased blood flow to the muscle; as a result, a decrease in insulin-stimulated glucose uptake would occur, leading to insulin resistance. Furthermore, beta-blockers can decrease first-phase insulin secretion and in addition cause weight gain, which increases insulin resistance and furtherly deteriorates glucose homeostasis. Disturbances in serum lipid levels induced by beta-blockers, including elevated triglyceride levels and reduced levels of HDL-C, may also contribute to impaired glycemic control (Rizos and Elisaf 2014).

Some precautions may help to prevent glycemic side effects secondary to beta-blocking agents. The use of low dosages combined with other agents, particularly CCBs, is highly recommended. Limiting weight gain and improving physical activity may also reduce the risk of hyperglycemia induced by beta-blocking agents (Fathallah et al. 2015).

## CCBs

Intracellular calcium metabolism is a well-known key regulator of insulin secretion (Wollheim et al. 1978); therefore, in theory, CCBs may reduce insulin secretion and induce hyperglycemia in humans. On the other side, this effect is counterbalanced by CCB-induced vasodilation, which leads to increased peripheral glucose uptake and improved insulin sensitivity (Noto et al. 2013). As a consequence, CCBs appear to have no major impact on glucose metabolism, and they are considered as having an overall neutral metabolic profile (Amorim et al. 2001), as also confirmed by two recent meta-analyses (Noto et al. 2013; Yang et al. 2013) that have shown an insignificant overall risk of new-onset diabetes and neutral effects on insulin sensitivity.

However, not all members of the CCB class have the same effect on glucose homeostasis. Nifedipine, nifedipine (at high doses), verapamil, and diltiazem in cases of intoxication are the CCBs most frequently implicated in carbohydrate metabolism disturbances, primarily due to the blockade of pancreatic L-type calcium channels and insulin resistance at cellular level (Ahmad 1992; Levine et al. 2007).

On the other hand, azelnidipine has been associated with beneficial effects on glucose homeostasis, in a diabetic animal model and in nondiabetic patients. This

effect seems to be related to the anti-inflammatory properties of azelnidipine (Yamagishi et al. 2004) and to its inhibitory capacity on sympathetic nervous activation (Nada et al. 2007). Manidipine also seems to show advantageous effects on glucose metabolism (Rizos and Elisaf 2011), due to a beneficial effect on insulin resistance in both nondiabetic and type 2 diabetic patients. This favorable effect may be linked to the partial activation of the peroxisome proliferator-activated receptor gamma (PPAR $\gamma$ ) pathway, the increase of adiponectin levels, and the reduction of plasma norepinephrine (Rizos and Elisaf 2014).

---

## Lipid-Modifying Agents

### Statins

3-Hydroxy-3-methyl-glutaryl coenzyme-A (HMG-CoA) reductase inhibitors, also known as statins, are used for primary and secondary prevention of cardiovascular and cerebrovascular events and to reduce mortality (Bhattacharya et al. 2014; Ong et al. 2014; Shepherd et al. 2002; Ridker et al. 2012; Waters et al. 2013; Stone et al. 2014). Statins are generally well tolerated with common adverse effects including myalgia, elevations in creatine kinase, and impaired cognition (Brault et al. 2014; US Food and Drug Administration (FDA) 2012).

In 2012, the Food and Drug Administration (FDA) updated labeling for all statins to include a warning for increases in blood glucose, HbA1c, and fasting serum glucose levels, based on results of the Justification for the Use of Statin in Prevention: An Intervention Trial Evaluating Rosuvastatin (JUPITER) trial (Ridker et al. 2012; US Food and Drug Administration (FDA) 2012). In this trial, the risk of new-onset diabetes increased when a patient had one or more major risk factors for diabetes mellitus, which included metabolic syndrome, impaired fasting glucose, body mass index (BMI) greater than or equal to 30 kg/m<sup>2</sup>, and glycosylated hemoglobin of 6% or greater (Ridker et al. 2012). Additionally, in a recent study, the onset of newly diagnosed diabetes was investigated and stratified on the basis of risk factors (fasting blood glucose greater than 100 mg/dL, fasting triglycerides greater than 150 mg/dL, BMI greater than 30 kg/m<sup>2</sup>, and history of hypertension), in patients taking either atorvastatin 10 mg or simvastatin 40 mg versus atorvastatin 80 mg. The authors reported an increased risk of new-onset diabetes in the atorvastatin 80 mg group, only in patients with two to four risk factors (Waters et al. 2013). In 2014, the Statin Diabetes Task Force considered that the risk of developing type 2 diabetes mellitus with statin use may be limited to patients with pre-existing risk factors for diabetes mellitus (Maki et al. 2014). The American Diabetes Association (ADA) recognizes the increased risk of developing type 2 diabetes mellitus with statin therapy and suggests to screen those patients with risk factors for diabetes, when taking statins (Table 2). Ideally, screening should occur before initiation of statin therapy, although clinicians should not generally delay the initiation of statin therapy to await results from screening tests in a patient for whom statin therapy is indicated (American Diabetes Association 2015). However, the strength of

**Table 2** Criteria for screening for prediabetes and diabetes before (or concurrent with) initiation of statin therapy (American Diabetes Association 2015)

---

1. Consider testing all overweight adults (body mass index $\geq 25$ kg/m <sup>2</sup> ) with additional risk factors
<ul style="list-style-type: none"><li>• Physical inactivity</li><li>• Diabetes in first-degree relative</li><li>• High-risk race/ethnicity (e.g., African-American, Latino, Native American, Asian American, Pacific Islander)</li><li>• Woman who delivered a baby weighing <math>&gt;9</math> lb or was diagnosed with gestational diabetes mellitus</li><li>• Hypertension (defined as systolic/diastolic blood pressure <math>\geq 140/90</math> mmHg, or on antihypertensive therapy)</li><li>• HDL-C <math>&lt;35</math> mg/dL (0.90 mmol/L) and/or triglyceride level <math>&gt;250</math> mg/dL (2.82 mmol/L)</li><li>• Women with polycystic ovary syndrome</li><li>• HbA1c <math>\geq 5.7\%</math>, impaired glucose tolerance, or impaired fasting glucose on previous testing</li><li>• Other clinical conditions associated with insulin resistance (e.g., severe obesity, acanthosis nigricans)</li><li>• History of cardiovascular disease</li></ul>
2. For all other persons not meeting these criteria, diabetes testing should begin at 45 years of age
3. If results are normal, testing should be repeated at a minimum of 3-year intervals; may consider more frequent testing depending on the initial results and risk status

---

association between statin therapy and development of new-onset diabetes is controversial. In a meta-analysis (Sattar et al. 2010) of 13 statin therapy trials in 91,140 participants without diabetes at baseline, an excess of 174 cases of new-onset diabetes in participants receiving statins, compared with placebo or usual care, was reported, during an average follow-up period of approximately 4 years. The weighted odds ratio for new-onset diabetes was 1.09 (95% confidence interval [CI] 1.02–1.17) without substantial heterogeneity between trials. No clear evidence was present to suggest differences between the statins studied (atorvastatin, simvastatin, rosuvastatin, pravastatin, and lovastatin) regarding their associations with new-onset diabetes, although power was limited to infer differences. The number needed to treat over a 4-year period to produce 1 excess case of diabetes was 255.

The association between intensive-dose statin therapy (80 mg atorvastatin or simvastatin) and new-onset diabetes risk, compared with moderate-dose statin therapy (10 or 20 mg atorvastatin, 40 mg pravastatin, 20 or 40 mg simvastatin), showed that among participants assigned to receive intensive-dose statin therapy, the 8.8% developed new-onset diabetes compared with 8.0% assigned to moderate-dose statin therapy. The weighted odds ratio was 1.12 (95% CI 1.04–1.22), with no substantial heterogeneity between trials. The number needed to treat with intensive-dose statin therapy per year to produce 1 excess case of diabetes, compared with moderate-dose statin therapy, was 498 (this equates to 125 needed to treat during 4 years for comparison with the results mentioned previously). The number needed to treat to prevent 1 cardiovascular (CVD) event per year was 155. Thus, if 498 patients were treated for 1 year with intensive-dose statin therapy instead of moderate-dose statin therapy, the projected number of CVD events prevented would be 3.2, in comparison with 1 excess case of diabetes (Sattar et al. 2010). Using data

from a meta-analysis by the Cholesterol Treatment Trialists (Preiss et al. 2011), the authors estimated that treating 255 patients with statin therapy resulting in a 1 mmol/L (38.7 mg/dL) reduction in LDL-C would prevent 5.4 coronary heart disease (CHD) events (CHD death or nonfatal myocardial infarction) during 4 years, which understates the potential benefit because it does not account for the effect of statin treatment on stroke and revascularization or the potential for a greater benefit with higher-dose statin treatment. The evidence reviewed here indicates that statin use is associated with a modest, but statistically significant, overall increase in the odds for new-onset diabetes, with pooled results from clinical trials suggesting that the degree of increase is approximately 10–12% compared with placebo or usual care. The available evidence does not indicate any clear difference between statins studied in clinical outcome trials regarding their associations with diabetes risk, although the analyses conducted to date lack sufficient power to demonstrate such differences, if present. No change is recommended to current practice to consider alternatives to statin treatment in any subsets of patients on the basis of evidence for a modest increase in the risk for diabetes associated with statin therapy, because the benefits of statin therapy for CVD event reduction in patients at risk for diabetes (and with diabetes) have been amply demonstrated in randomized controlled clinical trials. Although diabetes mellitus is associated with a number of adverse outcomes, the changes observed in measures of glucose homeostasis with statin use have been small and are of uncertain clinical importance (Maki et al. 2014).

Possible pathophysiological mechanisms of statin-induced abnormalities in glucose metabolism have been suggested; however, none of them has been proven. One potential mechanism is via disruption of voltage-gated calcium channels in pancreatic beta cells. Statins may directly block L-type calcium channels, thereby inhibiting glucose-induced calcium signaling in beta cells and decreasing insulin secretion. Another mechanism involves a decreased translocation of the glucose transporter, GLUT4, on the intracellular membrane of both fat and muscle cells, resulting in decreased glucose uptake in cells and ultimately leading to hyperglycemia. Other proposed mechanisms include peripheral insulin resistance as a result of mitochondrial dysfunction in cells (including fat cells and pancreatic beta cells) and chronic depletion of cellular cholesterol, resulting in impaired insulin secretion. Whether a statin is hydrophilic or lipophilic may account for alteration of glucose control. Hydrophilic statins (i.e., pravastatin and rosuvastatin) require carrier-mediated uptake into cells, thus increasing selectivity for hepatic cells. Lipophilic statins are able to passively diffuse through membranes of the hepatic cells but can also diffuse into extrahepatic tissues and disrupt cellular processes, including decreased insulin secretion in response to glucose. Finally, induction of muscle fatigue and reduced energy, culminating in diminished exercise potential and decreased activity and thus diminished energy expenditure, and perpetuation of the sarcopenia (skeletal muscle wasting) of aging leading to increased insulin resistance have also been suggested (Brault et al. 2014; Maki et al. 2014).

In conclusion, statins have been associated with a small but statistically significant risk. This risk is not considered to be clinically significant (due to small increases in absolute risk, particularly in meta-analyses of multiple studies),

was inconsistent across published evidence, and is likely outweighed by statins' benefits on cardiovascular risk reduction. Future research should focus on directly comparing the risk of new-onset diabetes versus risk of cardiovascular events and accounting for all potential factors that could increase the risk of new-onset diabetes.

## Nicotinic Acid

Nicotinic acid is a B vitamin recommended for the treatment of dyslipidemia (Pieper 2003). Although it has significant beneficial effects in increasing HDL-C levels and decreasing triglyceride and LDL-C levels, severe hyperglycemia secondary to niacin therapy has been reported in many cases.

An increase of fasting glucose levels has been reported after 2 weeks of niacin therapy, with the largest rise seen in the older group, with impaired glucose tolerance (Chang et al. 2006).

In a recent research study, niacin significantly increased plasma glucose, insulin, and C-peptide levels in sedentary nondiabetic postmenopausal women. The authors concluded that the use of niacin in postmenopausal women should proceed with caution under medical supervision (Koh et al. 2014).

In contrast, some studies have reported no changes or a decrease in glucose with niacin therapy. Indeed, in a study conducted on nonobese, healthy, physically active men and women with normal glucose tolerance, glucose levels decreased from baseline during 4 h of continuous intravenous infusion of niacin (Skowronski et al. 1992).

Niacin-induced hyperglycemia is most frequently associated with high doses, prediabetes, or diabetes. Moreover, aging (which is often associated with insulin resistance) is among the risk factors for hyperglycemia during niacin therapy (Kahn et al. 1989).

The mechanism of niacin-induced hyperglycemia is complex. An increase in hepatic gluconeogenesis as a result of smaller amounts of fatty acids in the liver and impairment of beta-cell compensation, leading to insulin resistance (especially in elderly patients), are the most frequently suggested mechanisms of niacin-induced hyperglycemia (Kahn et al. 1989).

---

## Antiarrhythmics

Some antiarrhythmic drugs have been associated with hyperglycemia and even diabetes (Salerno et al. 1988).

In patients with encainide-induced diabetes, basal and peak C-peptide concentrations were similar to controls, although peak C-peptide, following an oral mixed meal, occurred substantially later than in controls. At peak glucose, the patient's C-peptide/glucose ratio was low indicating relative (but not absolute) insulinopenia. The proposed mechanism of this disorder is an increase in the plasma glucagon level. Following the oral mixed meal, an increase in glucagon of 100% over baseline

compared to a mean glucagon rise in controls of only 8% was observed (Winter et al. 1992).

Hyperglycemia has been reported after long-term use of amiodarone in adults, as described in three case reports (Politi et al. 1984) but also as a precocious complication of amiodarone infusion in infants, during the early postoperative period (Yildirim et al. 2005). However, the mechanisms of amiodarone-induced hyperglycemia remain undetermined.

---

## Anti-infectives

### Antibiotics

Fluoroquinolones are the only class of antibiotics consistently associated with the development of hyperglycemia. The most commonly implicated fluoroquinolone is gatifloxacin, whereas levofloxacin is weakly implicated (Park-Wyllie et al. 2006). Interestingly, gatifloxacin is also associated with the development of hypoglycemia. The proposed hypoglycemic mechanism involves binding of the antibiotic to the pancreatic beta-cell similar to the action of sulfonylureas (Saraya et al. 2004). The mechanism for fluoroquinolone-associated hyperglycemia has not been precisely elucidated, but hyperglycemia has been reported to occur with gatifloxacin within 5 days of initiation of therapy (LaPlante et al. 2008).

In one study (Park-Wyllie et al. 2006), involving residents  $\geq 66$  years of age in Ontario, Canada, when compared with macrolide antibiotics (e.g., azithromycin and clarithromycin), gatifloxacin was associated with a substantially higher risk of hyperglycemia (adjusted odds ratio 16.7 [95% CI 10.4–26.8]).

The mechanisms responsible for fluoroquinolone-induced hyperglycemia have been linked to the action of the drugs on glucose transporter type (GLUT) 1. However, the negative impact on carbohydrate metabolism, due to an increased glucose and lipid flux, of infection per se, should also be considered.

In conclusion, fluoroquinolone-treated patients with diabetes should be carefully monitored, and treatment should be stopped, when needed. Although no specific guidelines on gatifloxacin-induced hyperglycemia are available, avoiding the use of gatifloxacin in patients with diabetes has been proposed (Park-Wyllie et al. 2006).

### Antimycobacterials

Among antimycobacterials, isoniazid has been more frequently involved in drug-induced hyperglycemia and diabetes, possibly through an inhibition of specific steps of Krebs cycle requiring  $\text{NAD}^+$  and a stimulation of glucagon secretion. Several studies have demonstrated an increased insulin requirement in diabetic patients, on

isoniazid treatment (Sridhar et al. 2012; Makarovsky et al. 2008; Luntz and Smith 1953; Manish et al. 2015).

Rifampicin-induced hyperglycemia, associated with increased rates of insulin and C-peptide secretion after oral administration of glucose, among patients with pulmonary tuberculosis has also been reported. Hyperglycemia induced by rifampicin appears shortly after rifampicin initiation and completely disappears a few days after the drug discontinuation and seems to be mainly due to an increased intestinal absorption of glucose, secondary to rifampicin ingestion (Takasu et al. 1982).

## Antivirals

Nucleoside analogue reverse transcriptase inhibitors (NRTIs) and protease inhibitors (PIs) are currently employed as anti-HIV combination therapy. Antiretroviral therapy has much improved life expectancy, but it has been associated with new-onset type 2 diabetes, in particular after short-term exposure to stavudine, indinavir, and didanosine (Capeau et al. 2012).

Pancreatitis is a serious adverse effect of didanosine, and hyperglycemia has been thought to be related in part to drug-induced pancreatic toxicity (Albrecht et al. 1993).

PI-induced hyperglycemia may occur in both diabetics and nondiabetics (Reus et al. 2000; Gómez-Vera et al. 2000) and is related to a typical lipodystrophy, with visceral fat accumulation, and development of metabolic syndrome (Capeau et al. 2012; Samaras 2009).

Up to 50% of patients may be affected by lipodystrophy after 10 months of therapy with a protease inhibitor. Type 2 diabetes or impaired glucose tolerance may be present in up to 25% of patients.

As a consequence of central fat accumulation, insulin sensitivity decreases, and the combination of insulin resistance without augmented beta-cell response may explain hyperglycemia and the other metabolic abnormalities seen in some protease inhibitor-treated patients (Dubé et al. 2001).

Ritonavir has been shown to induce hyperglycemia and insulin resistance, through direct inhibition of GLUT4 activity in vivo (Vyas et al. 2010). Atazanavir is the first PI approved by the US Food and Drug Administration (FDA) with the property of not inhibiting GLUT4. So, atazanavir is thought to not disturb glycemic and lipid levels as do the other PIs. In fact, a recent retrospective study, comparing darunavir and atazanavir, reported a multivariable-adjusted hazard ratio of 0.84 for diabetes and hyperglycemia, and in comparison with darunavir-treated patients, atazanavir-treated patients had significantly lesser metabolic side effects (Johnston et al. 2013).

Baseline glucose levels should be determined prior to PI therapy, and follow-up tests should be performed every 3–4 months during the first year of therapy. If glucose levels remain within the normal range, monitoring may be performed less frequently (Dubé et al. 2001).

## Antiprotozoals

Pentamidine therapy has been associated with alterations in blood glucose homeostasis (both hypo- and hyperglycemia). Newly diagnosed insulin-dependent diabetes mellitus following pentamidine therapy has also been reported. The mechanisms of pentamidine-induced hyperglycemia seem to be related to a direct negative impact of the drug on pancreatic beta cells (Liegler et al. 1994; Shen et al. 1989; Coyle et al. 1996).

---

## Drugs Affecting the Nervous System

### Antiepileptics

Both phenytoin and valproic acid have been associated with impaired glucose tolerance.

Phenytoin-induced hyperglycemia is a reversible condition, observed at toxic doses (Fariss and Litcher 1971), but it is apparently neutral on glucose tolerance, when used in therapeutic doses. In vitro studies have demonstrated that the addition of phenytoin to a primary culture system of adipocytes is associated with a 57% reduction in maximum [<sup>14</sup>C]3-*O*-methylglucose transport (Al-Rubeaan and Ryan 1991).

The wide use of valproic acid (VPA) as antiepileptic medication and first-line mood stabilizer for both acute bipolar mania and bipolar depression (Perucca 2002; Yatham et al. 2013) has led to increasing awareness of side effects, including increased appetite and weight gain. In particular, long-term treatment can lead to significant weight gain in 10–70% of patients and has been shown to lead to a number of metabolic disturbances that may promote the emergence of metabolic syndrome, particularly mediated by the increase in body weight (Belcastro et al. 2013; Verrotti et al. 2010).

### Antipsychotic Drugs

Although the increased prevalence of obesity and type 2 diabetes is well known in patients with schizophrenia and weight gain is a well-established side effect of antipsychotic drug therapy, the relative impact of the different factors on glucose metabolism is still unclear.

The different antipsychotic drugs differently impact on body weight and are greatest with the second-generation antipsychotics (SGAs) clozapine and olanzapine. However, long-term therapy with almost all antipsychotics has been associated with weight gain, with wide interindividual variations, more frequently in women (Gonçalves et al. 2015). Among the possible mechanisms of weight gain, antagonism of the hypothalamic H1 receptors and 5-HT<sub>2C</sub> receptors has been reported (Deng 2013).



Since 1995, there have been several published reports of diabetes mellitus occurring in association with clozapine therapy. The spectrum of reported illness has ranged from mild glucose intolerance to diabetic ketoacidosis and nonketotic hyperosmolar coma. In 1998, a specific study on the prevalence of diabetes and impaired glucose tolerance, during treatment of clozapine (Hagg et al. 1998), reported an increased incidence of glycemic abnormalities in clozapine-treated patients, as compared with patients treated with conventional neuroleptics. Stronger evidence was recently provided in a 5-year observational study (Henderson et al. 2000). Thirty of eighty-two clozapine-treated patients (36%) developed diabetes by 60 months of treatment, including twenty-two (27%) who required treatment with oral agents or insulin. There was no correlation between weight gain and development of diabetes. A descriptive epidemiologic study of spontaneous adverse event reports identified a causal relationship between clozapine and diabetes, suggested by the number of reports, the temporal relation to clozapine initiation, the relatively young age of the affected patients, and the prompt reversibility on withdrawal of the drug in some patients. The severity of reported cases ranged from mild glucose intolerance to diabetic ketoacidosis or hyperosmolar coma (Koller et al. 2001).

Hyperglycemia and diabetes mellitus have been described in 0.1–1% of patients receiving olanzapine therapy (Fertig et al. 1998). Olanzapine has been associated with a higher risk of incident diabetes than risperidone (Henderson et al. 2000). Even severe hyperglycemia or exacerbation of pre-existing diabetes, sometimes leading to ketoacidosis, coma, or death, has occurred with olanzapine (Nakamura and Nagamine 2010). In a review by Koller and Doraiswamy, 237 patients were identified with olanzapine-induced hyperglycemia, and 188 involved new-onset diabetes mellitus, among them 80 patients presented with metabolic acidosis (Koller and Doraiswamy 2002).

Olanzapine and clozapine have been associated with hyperglycemia, either secondary to weight gain and dyslipidemia or independent of any weight disturbances.

Ziprasidone is another SGA that has been associated with a case of severe hyperosmolar hyperglycemia (Létourneau et al. 2011) and a case report of new onset of diabetes mellitus (Sánchez-Barranco 2005).

The mechanisms of antipsychotic-associated hyperglycemia, diabetes mellitus, and ketoacidosis are complex. The increase in adipose tissue may contribute to insulin resistance (Tsuchiyama et al. 2004). However, cases of new-onset diabetes mellitus in the absence of weight gain have also been reported (Baptista et al. 2000). In fact, although weight gain with an increased body mass index is a common problem with antipsychotics, some reports have suggested that SGA-induced hyperglycemia and diabetes mellitus without significant weight gain may be present at the time of presentation, supporting the hypothesis of a more direct antipsychotic-mediated effect on glucose metabolism and homeostasis, independent of adiposity (Griffin et al. 1999). An impact on insulin secretion has also been reported, possibly involving blockade of central and peripheral muscarinic (M3) receptors. It may be relevant that the drugs with the highest diabetogenic risk, olanzapine and clozapine, also possess the greatest M3 receptor-binding affinity (Correll et al. 2015).

A regular screening for diabetes mellitus should be performed at the start and every 6 months in high-risk patients. Patients with diabetes mellitus receiving SGAs should be monitored regularly for worsening glucose control (American Diabetes Association 2011).

## Antidepressant Drugs

Many studies have reported an increased incidence of hyperglycemia and diabetes mellitus in antidepressant users (Rubin et al. 2008; Andersohn et al. 2009; Derijks et al. 2008).

In the Diabetes Prevention Program, the use of antidepressants at baseline was associated with an increased risk of type 2 diabetes, at follow-up (Rubin et al. 2008). Hyperglycemia was reported following treatment with clomipramine, fluvoxamine, imipramine, mianserin, mirtazapine, paroxetine, and sertraline, and the time to the onset of glucose dysregulation ranged from 4 days to 5 months after initiation of antidepressant therapy (Andersohn et al. 2009).

However, the effects of antidepressants on glucose metabolism could be related to changes in mood and lifestyle (Khoza and Barner 2011) and are time depending (Andersohn et al. 2009).

Moreover, the effect of antidepressants on glycemic control seems to differ according to the antidepressant class. Treatment with tricyclic antidepressants (TCAs) has been associated with hyperglycemia and worsening of glycemic control by inducing weight gain and insulin resistance (Aronne and Segal 2003), while in short-term therapy, selective serotonin reuptake inhibitors (SSRIs) and bupropion have resulted in a decrease in plasma glucose levels, leading to an improvement in glycemia (Lustman et al. 2000, 2006), but hyperglycemia may adversely occur with SSRIs in long-term use (Demyttenaere and Jaspers 2008).

Analyses of data drawn from a cohort of 150,000 adults revealed that antidepressant agents – especially when exceeding defined daily doses – are associated with an increase in the risk of diabetes mellitus. Moreover, the 5-year risk of diagnosed diabetes increases in a dose-response way. In this analysis, weight gain was more rapid among long-term antidepressant users than in nonusers matched for depression-related characteristics (Khoza and Barner 2011). Moreover, women appear to be more likely to be at risk of glucose dysregulation when taking antidepressants (Kessler et al. 2005). Reversible nonketotic hyperglycemia induced by amoxapine developed in a woman with a history of nonketotic hyperglycemic coma under preloxapine treatment (Tollefson and Lesar 1983).

---

## Antineoplastic Agents

Hyperglycemia is involved in the adverse outcomes, such as infections and non-malignancy-related mortality, in patients receiving chemotherapy, possibly through an increased risk for development of clinical toxicities, grade 4 neutropenia,

neutropenic fever, sepsis, and neuropathy. As a consequence, hyperglycemia during cancer treatment is one of the clinical toxicities that can cause chemotherapy dose delays or reductions and decrease the response to chemotherapeutic agents. Understanding the contributors to hyperglycemia in patients with a solid tumor cancer is, therefore, essential for improving outcomes (Hershey et al. 2014).

Some chemotherapeutic agents have been shown to carry a higher risk of hyperglycemia (Crouthamel et al. 2009), in particular, docetaxel, alone or in combination with other agents, decitabine, bortezomib, temozolomide, and vorinostat (Derr et al. 2009; Haas et al. 2014; Benton et al. 2014; Ciombor et al. 2014).

An increased risk of hyperglycemia and diabetes has also been associated to androgen deprivation therapy (Hershey et al. 2014). In a case report, cyclophosphamide-induced hyperglycemia was associated with the onset of type 1 diabetes (Atlan-Gepner et al. 1998). Hyperglycemia may occur in about 10% of patients receiving L-asparaginase, and diabetic ketoacidosis is a rare and severe complication of L-asparaginase therapy in children with acute leukemia (Mondal et al. 2011; Roberson et al. 2008). The risk of developing DKA is increased in older patients, possibly due to the association between insulin resistance and increased growth hormone secretion observed during late childhood and adolescence.

An asparaginase-induced defect in pancreatic beta-cell secretion is likely to represent the key factor in drug-induced hyperglycemia (Roberson et al. 2008).

---

## Immunosuppressive Agents

Among calcineurin inhibitors (CNIs), widely used as immunosuppressives in transplantation therapy, tacrolimus has been consistently shown to induce hyperglycemia compared with cyclosporine. In patients developing hyperglycemia, conversion from tacrolimus to cyclosporine is in fact associated with an improvement or a reversion of glucose tolerance abnormalities.

Data for other immunosuppressive agents (mycophenolate mofetil [MMF], sirolimus) are few and conflicting, while daclizumab seems to have a neutral effect. The switch to sirolimus from calcineurin inhibitor was recently associated with a 30% increase in the incidence of impaired glucose tolerance and the occurrence of diabetes, in 41 kidney transplanted patients. However, no difference in the incidence of diabetes was reported in kidney recipients whether they received sirolimus or MMF (Teutonico et al. 2005; Gonwa et al. 2005).

Several mechanisms have been proposed to explain CNI-induced hyperglycemia, including decreased insulin secretion and a direct apoptotic effect on the pancreatic beta cells.

Well-designed studies in this specific indication are lacking; therefore, hyperglycemia should be treated as in type 2 diabetes mellitus. However, sulfonylureas should be avoided, due to their interaction with calcineurin inhibitors, and good preliminary results have been obtained with incretin-based therapies, due to their

specific action on beta-cell apoptosis and proliferation (Penforinis and Kury-Paulin 2006; Boots et al. 2002).

Finally, interferon therapy has been associated with impaired glucose tolerance, with a frequency ranging from 0.1% to 0.6% (Okanoue et al. 1996; Fattovich et al. 1996). However, insulin therapy is generally unneeded (Fabris et al. 2003; Panetta and Gilani 2009; Yamazaki et al. 2010).

---

## Summary

This chapter describes almost all of the medications that may alter glycemic control. The evidence varies for individual drugs, and the underlying mechanisms are not entirely clear, but the emergence of drug-induced diabetes and dyslipidemia may adversely affect long-term health outcomes. Physicians should be aware of the existence of these drugs and the pathophysiological mechanisms responsible for dysglycemia. This last point is particularly important to start proper glucose-lowering strategy and careful follow-up of the patient. In addition, patients receiving these drugs should be educated about the importance of blood glucose monitoring, follow-up tests, and lifestyle choices.

---

## References

- Ahmad S. Nicardipine-induced hyperglycemia. *Am Fam Physician*. 1992;45(2):449–52.
- Sharma SN, Iyengar SS, Hegde KP. Nifedipine induced hyperglycaemia. *J Assoc Physicians India* 1990;38(9):673–4.
- Aksnes TA, Kjeldsen SE, Mancina G. The effect of antihypertensive agents on new-onset diabetes mellitus: time to amend the guidelines? *Am J Cardiovasc Drugs*. 2006;6:139–47.
- Albrecht H, Stellbrink HJ, Arastéh K. Didanosine-induced disorders of glucose tolerance. *Ann Intern Med*. 1993;119(10):1050.
- Alderman MH. New onset diabetes during antihypertensive therapy. *Am J Hypertens*. 2008;21(5):493–9.
- ALLHAT Officers and Coordinators for the ALLHAT Collaborative Research Group, The Antihypertensive and Lipid-Lowering Treatment to Prevent Heart Attack Trial. Major outcomes in high-risk hypertensive patients randomized to angiotensin converting enzyme inhibitor or calcium channel blocker vs diuretic: the Antihypertensive and Lipid-Lowering Treatment to Drug-Induced Hyperglycaemia and Diabetes Prevent Heart Attack Trial (ALLHAT). *JAMA*. 2002;288:2981–97.
- Al-Rubeaan K, Ryan EA. Phenytoin-induced insulin insensitivity. *Diabet Med*. 1991;8:968–70.
- American Diabetes Association. Position statement: standards of medical care in diabetes. *Diabetes Care*. 2011;34:S11–61.
- American Diabetes Association. Standards of medical care in diabetes-2015. *Diabetes Care*. 2015;38:S1–S93. <https://doi.org/10.2337/dc15-S003>.
- Amorim S, Dias P, Rocha G, et al. Poisoning with calcium channel blockers – a case report and review of the literature. *Rev Port Cardiol*. 2001;20(12):1249–57.
- Andersohn F, Schade R, Suissa S, et al. Long-term use of antidepressants for depressive disorders and the risk of diabetes mellitus. *Am J Psychiatry*. 2009;166:591–8.

- Anonymous. Adverse reactions to bendrofluazide and propranolol for the treatment of mild hypertension. Report of Medical Research Council Working Party on Mild to Moderate Hypertension. *Lancet*. 1981;2:539–43.
- Aronne LJ, Segal KR. Weight gain in the treatment of mood disorders. *J Clin Psychiatry*. 2003;64:22–9.
- Atlan-Gepner C, Bouabdallah R, Valero R, et al. A cyclophosphamide-induced autoimmune diabetes. *Lancet*. 1998;352(9125):373–4.
- Ayers K, Byrne LM, DeMatteo A, et al. Differential effects of nebivolol and metoprolol on insulin sensitivity and plasminogen activator inhibitor in the metabolic syndrome. *Hypertension*. 2012;59:893–8.
- Ayvaz G, Balos Törüner F, Karakoc A, et al. Acute and chronic effects of different concentrations of free fatty acids on the insulin secreting function of islets. *Diabete Metab*. 2002;28:3S7–12.
- Bakris GL, Fonseca V, Katholi RE, GEMINI Investigators, et al. Metabolic effects of carvedilol vs metoprolol in patients with type 2 diabetes mellitus and hypertension: a randomized controlled trial. *JAMA*. 2004;292(18):2227–36.
- Bangalore S, Parkar S, Grossman E, et al. A metaanalysis of 94,492 patients with hypertension treated with beta blockers to determine the risk of new-onset diabetes mellitus. *Am J Cardiol*. 2007;100(8):1254–62.
- Baptista T, Lacruz A, de Mendoza S, et al. Body weight gain after administration of antipsychotic drugs: correlation with leptin, insulin and reproductive hormones. *Pharmacopsychiatry*. 2000;33:81–8.
- Batra YK, Rajeev S, Samra T, et al. Octreotide-induced severe paradoxical hyperglycemia and bradycardia during subtotal pancreatectomy for congenital hyperinsulinism in an infant. *Paediatr Anaesth*. 2007;17(11):1117–9.
- Belcastro V, D'Egidio C, Striano P, et al. Metabolic and endocrine effects of valproic acid chronic treatment. *Epilepsy Res*. 2013;107(1–2):1–8. <https://doi.org/10.1016/j.eplepsyres.2013.08.016>.
- Benton CB, Thomas DA, Yang H, et al. Safety and clinical activity of 5-aza-20- deoxycytidine (decitabine) with or without hyper-CVAD in relapsed/refractory acute lymphocytic leukaemia. *Br J Haematol*. 2014;167:356–65.
- Bhattacharya R, Ajmera M, Bhattacharjee B. Use of antidepressants and statins and short-term risk of new-onset diabetes among high risk adults. *Diabetes Res Clin Pract*. 2014;105:251–60. <https://doi.org/10.1016/j.diabres.2014.04.016>.
- Blackburn D, Hux J, Mamdani M. Quantification of the risk of corticosteroid-induced diabetes mellitus among the elderly. *J Gen Intern Med*. 2002;17:717–20.
- Bollen M, Keppens S, Stalmans W. Specific features of glycogen metabolism in the liver. *Biochem J*. 1998;336(Pt 1):19–31.
- Boots JM, van Duijnhoven EM, Christiaans MH, et al. Glucose metabolism in renal transplant recipients on tacrolimus: the effect of steroid withdrawal and tacrolimus trough level reduction. *J Am Soc Nephrol*. 2002;13:221–7.
- Boudreaux JP, McHugh L, Canafax DM, et al. The impact of cyclosporine and combination immunosuppression on the incidence of posttransplant diabetes in renal allograft recipients. *Transplantation*. 1987;44(3):376–81.
- Brault M, Ray J, Gomez Y, et al. Statin treatment and new-onset diabetes: a review of proposed mechanisms. *Metabolism*. 2014;63:735–45.
- Brown MJ, Palmer CR, Castaigne A, et al. Morbidity and mortality in patients randomized to double-blind treatment with a long-acting calcium channel blocker or diuretic in the International Nifedipine GITS study: intervention as a Goal in Hypertension Treatment (INSIGHT). *Lancet*. 2000;356:366–72.
- Brown MJ, Williams B, Morant SV, British Hypertension Society's Prevention, Treatment of Hypertension with Algorithm-based Therapy (PATHWAY) Studies Group, et al. Effect of amiloride, or amiloride plus hydrochlorothiazide, versus hydrochlorothiazide on glucose tolerance and blood pressure (PATHWAY-3): a parallel-group, double-blind randomised phase 4 trial. *Lancet Diabetes Endocrinol*. 2016;4(2):136–47.

- Burt MG, Willenberg VM, Petersons CJ, et al. Screening for diabetes in patients with inflammatory rheumatological disease administered long-term prednisolone: a cross-sectional study. *Rheumatology (Oxford)*. 2012;51(6):1112–9.
- Capeau J, et al. Ten-year diabetes incidence in 1046 HIV-infected patients started on a combination antiretroviral treatment. *AIDS*. 2012;26(3):303–14. <https://doi.org/10.1097/QAD.0b013e32834e8776>.
- Carter BL, Einhorn PT, Brands M. Thiazide-induced dysglycemia: call for research from a working group from the national heart, lung, and blood institute. *Hypertension*. 2008;52:30–6.
- Chang AM, Smith MJ, Galecki AT, Bloem CJ, Halter JB. Impaired beta-cell function in human aging: response to nicotinic acid-induced insulin resistance. *J Clin Endocrinol Metab*. 2006;91(9):3303–9.
- Ciombor KK, Feng Y, Benson AB 3rd, et al. Phase II trial of bortezomib plus doxorubicin in hepatocellular carcinoma (E6202): a trial of the Eastern Cooperative Oncology Group. *Investig New Drugs*. 2014;32:1017–27.
- Cooper-DeHoff RM, Wen S, Beitelshees AL, et al. Impact of abdominal obesity on incidence of adverse metabolic effects associated with antihypertensive medications. *Hypertension*. 2010;55:61–8.
- Correll CU, Detraux J, De Lepeleire J, et al. Effects of antipsychotics, antidepressants and mood stabilizers on risk for physical diseases in people with schizophrenia, depression and bipolar disorder. *World Psychiatry*. 2015;14:119–36.
- Coyle P, Carr AD, Depczynski BB, et al. Diabetes mellitus associated with pentamidine use in HIV-infected patients. *Med J Aust*. 1996;165:587–8.
- Crook D, Godsland I. Safety evaluation of modern oral contraceptives: effects on lipoprotein and carbohydrate metabolism. *Contraception*. 1998;57:189–201.
- Crouthamel MC, Kahana JA, Korenchuk S, et al. Mechanism and management of AKT inhibitor-induced hyperglycemia. *Clin Cancer Res*. 2009;15(1):217–25.
- Dahlöf B, Devereux RB, Kjeldsen SE, LIFE Study Group, et al. Cardiovascular morbidity and mortality in the Losartan Intervention for Endpoint Reduction in Hypertension Study (LIFE): a randomized trial against atenolol. *Lancet*. 2002;359:995–1003.
- Demyttenaere K, Jaspers L. Review: bupropion and SSRI-induced side effects. *Psychopharmacology*. 2008;22:792–804.
- Deng C. Effects of antipsychotic medications on appetite, weight, and insulin resistance. *Endocrinol Metab Clin N Am*. 2013;42:545–63.
- Depczynski B, Daly B, Campbell LV, et al. Predicting the occurrence of diabetes mellitus in recipients of heart transplants. *Diabet Med*. 2000;17(1):15–9.
- Derijks HJ, Meyboom RH, Heerdink ER, et al. The association between antidepressant use and disturbances in glucose homeostasis: evidence from spontaneous reports. *Eur J Clin Pharmacol*. 2008;64:531–8.
- Derr RL, Ye X, Islas MU, et al. Association between hyperglycemia and survival in patients with newly diagnosed glioblastoma. *J Clin Oncol*. 2009;27(7):1082–6.
- Dirlewanger M, Schneiter PH, Paquot N, et al. Effects of glucocorticoids on hepatic sensitivity to insulin and glucagon in man. *Clin Nutr*. 2000;19:29–34.
- Duarte JD, Cooper-DeHoff RM. Mechanisms for blood pressure lowering and metabolic effects of thiazide and thiazide-like diuretics. *Expert Rev Cardiovasc Ther*. 2010;8(6):793–802.
- Dubé MP, Edmondson-Melançon H, Qian D, et al. Prospective evaluation of the effect of initiating indinavir-based therapy on insulin sensitivity and B-cell function in HIV-infected patients. *J Acquir Immune Defic Syndr*. 2001;27(2):130–4.
- Dunder K, Lind L, Zethelius B, et al. Increase in blood glucose concentration during antihypertensive treatment as a predictor of myocardial infarction: population based cohort study. *BMJ*. 2003;326:681.
- Elliott WJ, Meyer PM. Incident diabetes in clinical trials of antihypertensive drugs: a network meta-analysis. *Lancet*. 2007;369(9557):201–7.

- Eriksson JW, Jansson PA, Carlberg B, et al. Hydrochlorothiazide, but not candesartan, aggravates insulin resistance and causes visceral and hepatic fat accumulation: the Mechanisms for the Diabetes Preventing Effect of Candesartan (MEDICA) Study. *Hypertension*. 2008;52(6):1030–7.
- Fabris P, Floreani A, Tositti G, et al. Type 1 diabetes mellitus in patients with chronic hepatitis C before and after interferon therapy. *Aliment Pharmacol Ther*. 2003;18:549–58.
- Fain JN. Effects of dexamethasone and 2-deoxy-D-glucose on fructose and glucose metabolism by incubated adipose tissue. *J Biol Chem*. 1964;239:958–62.
- Fardet L, Fève B. Systemic glucocorticoid therapy: a review of its metabolic and cardiovascular adverse events. *Drugs*. 2014 Oct;74(15):1731–45. <https://doi.org/10.1007/s40265-014-0282-9>.
- Fariss BL, Lutcher CL. Diphenylhydantoin-induced hyperglycemia and impaired insulin release: effect of dosage. *Diabetes*. 1971;20(3):177–81.
- Fasshauer M, Paschke R. Regulation of adipocytokines and insulin resistance. *Diabetologia*. 2003;46:1594–603.
- Fathallah N, Slim R, Larif S, et al. Drug-induced hyperglycaemia and diabetes. *Drug Saf*. 2015;38:1153–68.
- Fattovich G, Giustina G, Favarato S, et al. A survey of adverse events in 11 241 patients with chronic viral hepatitis treated with alpha interferon. *J Hepatol*. 1996;24:38–47.
- Fertig MK, Brooks VG, Shelton PS, et al. Hyperglycemia associated with olanzapine. *J Clin Psychiatry*. 1998;59:687–9.
- Fisher JE, Smith RS, Lagrandeur R, et al. Gestational diabetes mellitus in women receiving beta-adrenergics and corticosteroids for threatened preterm delivery. *Obstet Gynecol*. 1997;90(6):880–3.
- Friedman EA, Shyh TP, Beyer MM, et al. Posttransplant diabetes in kidney transplant recipients. *Am J Nephrol*. 1985;5(3):196–202.
- Friedrich A, Ludwig AK, Jauch-Chara K, et al. Oral contraception enhances growth hormone responsiveness to hyper- and hypoglycaemia. *Diabet Med*. 2012;29(3):345–50.
- Gadelha MR, Bronstein MD, Brue T, et al. Pasireotide versus continued treatment with octreotide or lanreotide in patients with inadequately controlled acromegaly (PAOLA): a randomised, phase 3 trial. *Lancet Diabetes Endocrinol*. 2014;2(11):875–84.
- Garg AK. Hyperglycemia during replacement growth hormone therapy. *J Pediatr*. 1994;125:329.
- Gómez-Vera J, de Alarcón A, Jiménez-Mejías ME, et al. Hyperglycemia associated with protease inhibitors in HIV-1-infected patients. *Clin Microbiol Infect*. 2000;6:391–4.
- Gonçalves P, Araújo JR, Martel F. Antipsychotics-induced metabolic alterations: focus on adipose tissue and molecular mechanisms. *Eur Neuropsychopharmacol*. 2015;25(1):1–16. <https://doi.org/10.1016/j.euroneuro.2014.11.008>.
- Gonwa T, Mendez R, Yang HC, Prograf Study Group. Randomized trial of tacrolimus in combination with sirolimus or mycophenolate mofetil in kidney transplantation: results at 6 months. *Transplantation*. 2005;75:1213–20.
- Gress TW, Nieto FJ, Shahar E, et al. Hypertension and antihypertensive therapy as risk factors for type 2 diabetes mellitus. *Atherosclerosis Risk in Communities Study*. *N Engl J Med*. 2000;342:905–12.
- Griffin ME, Marcucci MJ, Cline GW, et al. Free fatty acid-induced insulin resistance is associated with activation of protein kinase C theta and alterations in the insulin signalling cascade. *Diabetes*. 1999;48:1270–4.
- Gulliford MC, Charlton J, Latinovic R. Risk of diabetes associated with prescribed glucocorticoids in a large population. *Diabetes Care*. 2006;29:2728–9.
- Gurwitz JH, Bohn RL, Glynn RJ, et al. Glucocorticoids and the risk for initiation of hypoglycemic therapy. *Arch Intern Med*. 1994;154:97–101.
- Haas NB, Quirt I, Hotte S, McWhirter E, Polintan R, Litwin S, et al. Phase II trial of vorinostat in advanced melanoma. *Investig New Drugs*. 2014;32(3):526–34.
- Hagg S, Joelsson L, Mjorndal T, et al. Prevalence of diabetes and impaired glucose tolerance in patients treated with clozapine compared with patients treated with conventional depot neuroleptic medications. *J Clin Psychiatry*. 1998;59:294–9.

- Hansen KB, Vilsboll T, Bagger JI, et al. Reduced glucose tolerance and insulin resistance induced by steroid treatment, relative physical inactivity, and high-calorie diet impairs the incretin effect in healthy subjects. *J Clin Endocrinol Metab.* 2010;95:3309–17.
- Hansen KB, Vilsboll T, Bagger JI, Holst JJ, Knop FK. Increased postprandial GIP and glucagon responses, but unaltered GLP-1 response after intervention with steroid hormone, relative physical inactivity, and high-calorie diet in healthy subjects. *J Clin Endocrinol Metab.* 2011;96:447–53.
- Hansen KB, Vilsboll T, Bagger JI, et al. Impaired incretin-induced amplification of insulin secretion after glucose homeostatic dysregulation in healthy subjects. *J Clin Endocrinol Metab.* 2012;97:1363–70.
- Henderson DC, Cagliero E, Gray C, et al. Clozapine, diabetes mellitus, weight gain, and lipid abnormalities: a five-year naturalistic study. *Am J Psychiatry.* 2000;157:975–81.
- Henriksen JE, Alford F, Vaag A, et al. Intracellular skeletal muscle glucose metabolism is differentially altered by dexamethasone treatment of normoglycemic relatives of type 2 diabetic patients. *Metabolism.* 1999;48:1128–35.
- Hershey DS, Bryant AL, Olausson J, et al. Hyperglycemic-inducing neoadjuvant agents used in treatment of solid tumors: a review of the literature. *Oncol Nurs Forum.* 2014;41:E343–54.
- Hirst JA, Farmer AJ, Feakins BG, et al. Quantifying the effects of diuretics and beta-blockers on glycaemic control in diabetes mellitus – a systematic review and meta-analysis. *Br J Clin Pharmacol.* 2015;79(5):733–43.
- Hoes JN, van der Goes MC, van Raalte DH, et al. Glucose tolerance, insulin sensitivity and beta-cell function in patients with rheumatoid arthritis treated with or without low-to-medium dose glucocorticoids. *Ann Rheum Dis.* 2011;70:1887–94.
- Hoffman A, Kuntze JE, Baptista J, et al. Growth hormone replacement therapy in adult-onset GH deficiency: effects on body composition in men and women in a double-blind, randomized, placebo-controlled trial. *J Clin Endocrinol Metab.* 2004;89:204–56.
- Huscher D, Thiele K, Gromnica-Ihle E, et al. Dose-related patterns of glucocorticoid-induced side effects. *Ann Rheum Dis.* 2009;68(7):1119–24.
- Hwang IT. Efficacy and safety of growth hormone treatment for children born small for gestational age. *Korean J Pediatr.* 2014;57(9):379–83.
- Ibrahim MM. Subcutaneous and visceral adipose tissue: structural and functional differences. *Obes Rev.* 2010;11:11–8.
- Issekutz B Jr, Borkow I. Effect of glucagon and glucose load on glucose kinetics, plasma FFA, and insulin in dogs treated with methylprednisolone. *Metabolism.* 1973;22:39–49.
- Jacob S, Rett K, Wicklmayr M, et al. Differential effect of chronic treatment with two beta blocking agents on insulin sensitivity: the Carvedilol–Metoprolol Study. *J Hypertens.* 1996;14:489–94.
- Jandeleit-Dahm KA, Tikellis C, Reid CM, et al. Why blockade of the renin–angiotensin system reduces the incidence of new-onset diabetes. *J Hypertens.* 2005;23:463–73.
- Jin JY, DuBois DC, Almon RR, et al. Receptor/gene-mediated pharmacodynamic effects of methylprednisolone on phosphoenolpyruvate carboxykinase regulation in rat liver. *J Pharmacol Exp Ther.* 2004;309:328–39.
- Johannsson G, Rose'n T, Bengtsson B. Individualized dose titration of growth hormone (GH) during GH replacement in hypopituitary adults. *Clin Endocrinol.* 1997;47:571–81.
- Johnston SS, Juday T, Esker S, et al. Comparative incidence and health care costs of medically attended adverse effects among US Medicaid HIV patients on atazanavir- or darunavir-based antiretroviral therapy. *Value Health.* 2013;16(2):418–25.
- Kahn SE, Beard JC, Schwartz MW, Ward WK, Ding HL, Bergman RN, et al. Increased beta-cell secretory capacity as mechanism for islet adaptation to nicotinic acid-induced insulin resistance. *Diabetes.* 1989;38(5):562–8.
- Kaplan SA, Shimizu CS. Effects of cortisol on amino acids in skeletal muscle and plasma. *Endocrinology.* 1963;72:267–72.



- Kessler RC, Berglund P, Demler O, et al. Lifetime prevalence and age-of-onset distributions of DSM-IV disorders in the National Comorbidity Survey Replication. *Arch Gen Psychiatry*. 2005;62:593–602.
- Khaleeli AA, Edwards RH, Gohil K, et al. Corticosteroid myopathy: a clinical and pathological study. *Clin Endocrinol*. 1983;18:155–66.
- Khoza S, Barner JC. Glucose dysregulation associated with antidepressant agents: an analysis of 17 published case reports. *Int J Clin Pharm*. 2011;33:484–92.
- Kim SY, Yoo C-G, Lee CT, et al. Incidence and risk factors of steroid-induced diabetes in patients with respiratory disease. *J Korean Med Sci*. 2011;26(2):264–7.
- Koh Y, Bidstrup H, Nichols DL. Niacin increased glucose, insulin, and C-peptide levels in sedentary nondiabetic postmenopausal women. *Int J Womens Health*. 2014;6:913–20.
- Koller EA, Doraiswamy PM. Olanzapine-associated diabetes mellitus. *Pharmacotherapy*. 2002;22:841–52.
- Koller E, Schneider B, Bennett K, et al. Clozapine-associated diabetes. *Am J Med*. 2001;111:716–23.
- Kostis JB, Wilson AC, Freudenberger RS, et al. Long-term effect of diuretic-based therapy on fatal outcomes in subjects with isolated systolic hypertension with and without diabetes. *Am J Cardiol*. 2005;95:29–35.
- Kraus-Friedmann N. Hormonal regulation of hepatic gluconeogenesis. *Physiol Rev*. 1984;64:170–259.
- Krebs M, Krssak M, Bemroider E, et al. Mechanism of amino acid-induced skeletal muscle insulin resistance in humans. *Diabetes*. 2002;51:599–605.
- LaPlante KL, Mersfelder TL, Ward KE, et al. Prevalence of and risk factors for dysglycemia in patients receiving gatifloxacin and levofloxacin in an outpatient setting. *Pharmacotherapy*. 2008;28:82–9.
- Lecocq FR, Mebane D, Madison LL. The acute effect of hydrocortisone on hepatic glucose output and peripheral glucose utilization. *J Clin Invest*. 1964;43:237–46.
- Létourneau G, Abdel-Baki A, Dubreucq S, Mahone M, Granger B. Hyperosmolar hyperglycemic state associated with ziprasidone treatment: a case report. *J Clin Psychopharmacol*. 2011;31:671–3.
- Levine M, Boyer EW, Pozner CN, et al. Assessment of hyperglycemia after calcium channel blocker overdoses involving diltiazem or verapamil. *Crit Care Med*. 2007;35(9):2071–5.
- Liegl U, Bogner JR, Goebel FD. Insulin-dependent diabetes mellitus following pentamidine therapy in a patient with AIDS. *Clin Investig*. 1994;72:1027–9.
- Liou YS, Chen HY, Tien L, et al. Antihypertensive drug use and new-onset diabetes in female patients with coronary artery disease: a population-based longitudinal cohort study. *Medicine (Baltimore)*. 2015;94(36):e1495.
- Lofberg E, Gutierrez A, Wernerman J, et al. Effects of high doses of glucocorticoids on free amino acids, ribosomes and protein turnover in human muscle. *Eur J Clin Investig*. 2002;32:345–53.
- Lopez LM, Grimes DA, Schulz KF. Steroidal contraceptives: effect on carbohydrate metabolism in women without diabetes mellitus. *Cochrane Database Syst Rev*. 2014;4:CD006133.
- Luntz GR, Smith SG. Effect of isoniazid on carbohydrate metabolism in controls and diabetics. *Br Med J*. 1953;1:296–9.
- Lustman PJ, Freedland KE, Griffith LS, et al. Fluoxetine for depression in diabetes: a randomized double-blind placebo-controlled trial. *Diabetes Care*. 2000;23:618–23.
- Lustman PJ, Clouse RE, Nix BD, et al. Sertraline for prevention of depression recurrence in diabetes mellitus: a randomized, double-blind, placebo-controlled trial. *Arch Gen Psychiatry*. 2006;63:521–9.
- Macfarlane DP, Forbes S, Walker BR. Glucocorticoids and fatty acid metabolism in humans: fuelling fat redistribution in the metabolic syndrome. *J Endocrinol*. 2008;197:189–204.
- Makarovsky I, Markel G, Dushnitsky T, et al. Hydrazine – the space era agent. *Isr Med Assoc J*. 2008;10:302–6.

- Maki KC, Ridker P, Brown W, et al. An assessment by the Statin Diabetes Safety Task Force: 2014 update. *J Clin Lipidol*. 2014;8:S17–29. <https://doi.org/10.1016/j.jacl.2014.02.012>.
- Manish G, Keshav GK, Syed RM, et al. Isoniazid induced childhood diabetes: a rare phenomenon. *J Basic Clin Pharm*. 2015;6(2):74–6.
- Messerli FH, Bangalore S, Yao SS, et al. Cardioprotection with beta-blockers: myths, facts and Pascal's wager. *J Intern Med*. 2009;266(3):232–41.
- Miyoshi H, Shulman GI, Peters EJ, et al. Hormonal control of substrate cycling in humans. *J Clin Invest*. 1988;81:1545–55.
- Mondal R, Nandi M, Tiwari A, et al. Diabetic ketoacidosis with L-asparaginase therapy. *Indian Pediatr*. 2011;48(9):735–6.
- Moore MJ, Gong Y, Hou W, et al. Predictors for glucose change in hypertensive participants following short-term treatment with atenolol or hydrochlorothiazide. *Pharmacotherapy*. 2014;34(11):1132–40.
- Muscogiuri G, Chavez AO, Gastaldelli A, et al. The crosstalk between insulin and renin angiotensin-aldosterone signaling systems and its effect on glucose metabolism and diabetes prevention. *Curr Vasc Pharmacol*. 2008;6:301–12.
- Nada T, Nomura M, Koshihara K, et al. Clinical study with azelnidipine in patients with essential hypertension. Antiartherosclerotic and cardiac hypertrophy-inhibitory effects and influence on autonomic nervous activity. *Arzneimittelforschung*. 2007;57(11):698–704.
- Nakamura M, Nagamine T. Severe hyperglycemia induced by olanzapine was improved with a recovery of insulin secretion after switching to risperidone and introducing insulin therapy. *Intern Med*. 2010;49:2635–7.
- Nielsen MF, Caumo A, Chandramouli V, et al. Impaired basal glucose effectiveness but unaltered fasting glucose release and gluconeogenesis during short-term hypercortisolemia in healthy subjects. *Am J Physiol Endocrinol Metab*. 2004;286:E102–10.
- Noto H, Goto A, Tsujimoto T, et al. Effect of calcium channel blockers on incidence of diabetes: a meta-analysis. *Diabetes Metab Syndr Obes*. 2013;6:257–61.
- Okanoue T, Sakamoto S, Itoh Y, et al. Side effects of high-dose interferon therapy for chronic hepatitis C. *J Hepatol*. 1996;25:283–91.
- Ong K, Waters DD, Messig M, et al. Effect of change in body weight on incident diabetes mellitus in patients with stable coronary artery disease treated with atorvastatin (from the treating to new targets study). *Am J Cardiol*. 2014;113:1593–8.
- Ouchi N, Parker JL, Lugus JJ, et al. Adipokines in inflammation and metabolic disease. *Nat Rev Immunol*. 2011;11:85–97.
- Panetta JD, Gilani N. Interferon-induced retinopathy and its risk in patients with diabetes and hypertension undergoing treatment for chronic hepatitis C virus infection. *Aliment Pharmacol Ther*. 2009;30:597–602.
- Park-Wyllie LY, Juurlink DN, Kopp A, et al. Outpatient gatifloxacin therapy and dysglycemia in older adults. *N Engl J Med*. 2006;354:1352–61.
- Peckett AJ, Wright DC, Riddell MC. The effects of glucocorticoids on adipose tissue lipid metabolism. *Metabolism*. 2011;60:1500–10.
- Penforinis A, Kury-Paulin S. Immunosuppressive drug-induced diabetes. *Diabete Metab*. 2006;32:539–46.
- Perseghin G, Petersen K, Shulman GI. Cellular mechanism of insulin resistance: potential links with inflammation. *Int J Obes Relat Metab Disord*. 2003;27(Suppl 3):S6–11.
- Perucca E. Pharmacological and therapeutic properties of valproate: a summary after 35 years of clinical experience. *CNS Drugs*. 2002;16(10):695–714.
- Pieper JA. Overview of niacin formulations: differences in pharmacokinetics, efficacy, and safety. *Am J Health Syst Pharm*. 2003;60:S9–14.
- Politi A, Poggio G, Margiotta A. Can amiodarone induce hyperglycaemia and hypertriglyceridaemia? *Br Med J (Clin Res Ed)*. 1984;288(6413):285.
- Preiss D, Seshasai SR, Welsh P, et al. Risk of incident diabetes with intensive-dose compared with moderate-dose statin therapy: a meta analysis. *JAMA*. 2011;305:2556–64.

- Ranta F, Avram D, Berchtold S, et al. Dexamethasone induces cell death in insulin-secreting cells, an effect reversed by exendin-4. *Diabetes*. 2006;55:1380–90.
- Reed ML, Merriam GR, Kargi AY. Adult growth hormone deficiency – benefits, side effects, and risks of growth hormone replacement. *Front Endocrinol (Lausanne)*. 2013;4:64. <https://doi.org/10.3389/fendo.2013.00064>. eCollection 2013.
- Reus S, Arroyo E, Boix V, et al. Lipodystrophy and hyperglycemia produced by protease inhibitors. *An Med Interna*. 2000;17(3):123–6.
- Ridker PM, Pradhan A, MacFadyen JG, et al. Cardiovascular benefits and diabetes risks of statin therapy in primary prevention: an analysis from the JUPITER trial. *Lancet*. 2012;380:565–71.
- Rizos CV, Elisaf MS. Manidipine: a different dihydropyridine. *World J Hypertens*. 2011;1:3–6.
- Rizos CV, Elisaf MS. Antihypertensive drugs and glucose metabolism. *World J Cardiol*. 2014;6(7):517–30.
- Rizza RA, Mandarino LJ, Gerich JE. Cortisol-induced insulin resistance in man: impaired suppression of glucose production and stimulation of glucose utilization due to a postreceptor defect of insulin action. *J Clin Endocrinol Metab*. 1982;54:131–8.
- Roberson JR, Raju S, Shelso J, et al. Diabetic ketoacidosis during therapy for pediatric acute lymphoblastic leukemia. *Pediatr Blood Cancer*. 2008;50(6):1207–12.
- Ronchi C, Epaminonda P, Cappiello V, et al. Effects of two different somatostatin analogs on glucose tolerance in acromegaly. *J Endocrinol Investig*. 2002;25(6):502–7.
- Rooney DP, Neely RD, Cullen C, et al. The effect of cortisol on glucose/glucose-6-phosphate cycle activity and insulin action. *J Clin Endocrinol Metab*. 1993;77:1180–3.
- Rosei EA, Rizzoni D. Metabolic profile of nebivolol, a beta-adrenoreceptor antagonist with unique characteristics. *Drugs*. 2007;67:1097–10.
- Rubin RR, Ma Y, Marrero DG, et al. Elevated depression symptoms, antidepressant medicine use, and risk of developing diabetes during the Diabetes Prevention Program. *Diabetes Care*. 2008;31:420–6.
- Ruzzin J, Wagman AS, Jensen J. Glucocorticoid-induced insulin resistance in skeletal muscles: defects in insulin signalling and the effects of a selective glycogen synthase kinase-3 inhibitor. *Diabetologia*. 2005;48:2119–30.
- Saad MJ, Folli F, Kahn JA, et al. Modulation of insulin receptor, insulin receptor substrate-1, and phosphatidylinositol 3-kinase in liver and muscle of dexamethasone-treated rats. *J Clin Invest*. 1993;92:2065–72.
- Salerno DM, Fifield J, Krejci J, Hodges M. Encainide-induced hyperglycemia. *Am J Med*. 1988;84(1):39–44.
- Samaras K. Prevalence and pathogenesis of diabetes mellitus in HIV-1 infection treated with combined antiretroviral therapy. *J Acquir Immune Defic Syndr*. 2009;50(5):499–505. <https://doi.org/10.1097/QAI.0b013e31819c291b>.
- Samson SL. Long-term medical treatment of Cushing's disease with pasireotide: a review of current evidence and clinical experience. *Exp Clin Endocrinol Diabetes*. 2014;122(8):445–50.
- Samuelsson O, Hedner T, Berglund G, et al. Diabetes mellitus in treated hypertension: incidence, predictive factors and the impact of non-selective beta-blockers and thiazide diuretics during 15 years treatment of middle-aged hypertensive men in the Primary Prevention Trial Goteborg, Sweden. *J Hum Hypertens*. 1994;8:257–63.
- Sánchez-Barranco P. New onset of diabetes mellitus with ziprasidone: a case report. *J Clin Psychiatry*. 2005;66(2):268–9.
- Saraya A, Yokokura M, Gonoi T, et al. Effects of fluoroquinolones on insulin secretion and beta-cell ATP-sensitive K<sup>+</sup> channels. *Eur J Pharmacol*. 2004;497:111–7.
- Sattar N, Preiss D, Murray HM, et al. Statins and risk of incident diabetes: a collaborative meta-analysis of randomised statin trials. *Lancet*. 2010;375:735–42.
- Savage PJ, Pressel SL, Curb JD, et al. Influence of long-term, low dose, diuretic based, antihypertensive therapy on glucose, lipid, uric acid, and potassium levels in older men and women with isolated systolic hypertension: the Systolic Hypertension in the Elderly Program. SHEP Cooperative Research Group. *Arch Intern Med*. 1998;158:741–51.

- Scheen AJ. Renin-angiotensin system inhibition prevents type 2 diabetes mellitus. Part 2. Overview of physiological and biochemical mechanisms. *Diabete Metab.* 2004;30:498–505.
- Schneider P, Tappy L. Kinetics of dexamethasone-induced alterations of glucose metabolism in healthy humans. *Am J Phys.* 1998;275(5 Pt1):E806–13.
- Shafi T, Appel LJ, Miller ER 3rd, et al. Changes in serum potassium mediate thiazide-induced diabetes. *Hypertension.* 2008;52:1022–9. <https://doi.org/10.1161/HYPERTENSIONAHA.108.119438>.
- Shen M, Orwoll ES, Conte JE Jr, et al. Pentamidine-induced pancreatic beta-cell dysfunction. *Am J Med.* 1989;86:726–8.
- Shen L, Shah BR, Reyes EM, et al. Role of diuretics, b blockers, and statins in increasing the risk of diabetes in patients with impaired glucose tolerance: reanalysis of data from the NAVIGATOR study. *BMJ.* 2013;347:f6745. <https://doi.org/10.1136/bmj.f6745>.
- Shepherd J, Blauw GJ, Murphy MG, et al. Pravastatin in elderly individuals at risk of vascular disease (PROSPER): a randomised controlled trial. *Lancet.* 2002;360:1623–30.
- Short KR, Bigelow ML, Nair KS. Short-term prednisone use antagonizes insulin's anabolic effect on muscle protein and glucose metabolism in young healthy people. *Am J Physiol Endocrinol Metab.* 2009;297:E1260–8.
- Skowronski R, Hollenbeck CB, Jaspan JB, Reaven GM, Landau C, Chen YD. Effect of nicotinic acid on plasma glucose concentration in normal individuals. *Horm Metab Res.* 1992;24(9):424–8.
- Sridhar A, Sandeep Y, Krishnakishore C, et al. Fatal poisoning by isoniazid and rifampicin. *Indian J Nephrol.* 2012;22:385–7.
- Stone NJ, Robinson J, Lichtenstein AH, et al. 2014 ACC/AHA guideline on the treatment of blood cholesterol to reduce atherosclerotic cardiovascular risk in adults. *Circulation.* 2014;129:S1–S45.
- Suissa S, Kezouh A, Ernst P. Inhaled corticosteroids and the risks of diabetes onset and progression. *Am J Med.* 2010;123(11):1001–6.
- Takasu N, Yamada T, Miura H, et al. Rifampicin-induced early phase hyperglycemia in humans. *Am Rev Respir Dis.* 1982;125(1):23–7.
- Teutonico A, Schena PF, Di Paolo S. Glucose metabolism in renal transplant recipients: effect of calcineurin inhibitor withdrawal and conversion to sirolimus. *J Am Soc Nephrol.* 2005;16:3128–35.
- Tham DM, Martin-McNully B, Wang YX, et al. Angiotensin II is associated with activation of NF- $\kappa$ B-mediated genes and downregulation of PPARs. *Physiol Genomics.* 2002;11(1):21–30.
- Tollefson G, Lesar T. Nonketotic hyperglycemia associated with loxapine and amoxapine: case report. *J Clin Psychiatry.* 1983;44:347–8.
- Tourniaire J, Bajard L, Harfouch M, et al. Restoration of insulin sensitivity after correction of hypokalemia due to chronic tubulopathy in a diabetic patient. *Diabete Metab.* 1988;14(6):717–20.
- Tsuchiyama N, Ando H, Ota T, et al. Modulating effects of olanzapine on the development of diabetic ketoacidosis. *Diabet Med.* 2004;21:300–1.
- Turnbow MA, Keller SR, Rice KM, et al. Dexamethasone down-regulation of insulin receptor substrate-1 in 3T3-L1 adipocytes. *J Biol Chem.* 1994;269:2516–20.
- US Food and Drug Administration (FDA). Drugs: FDA safety communication: important safety label changes to cholesterol-lowering statin drugs. 2012. <http://www.fda.gov/drugs/drugsafety/ucm293101.htm>. Accessed 7 Jan 2014.
- Uzu T, Harada T, Sakaguchi M, et al. Glucocorticoid-induced diabetes mellitus: prevalence and risk factors in primary renal diseases. *Nephron Clin Pract.* 2007;105:c54–7.
- van Raalte SH, Diamant M. Steroid diabetes: from mechanism to treatment? *Neth J Med.* 2014;72(2):62–72.
- van Raalte DH, Nofrate V, Bunck MC, et al. Acute and 2-week exposure to prednisolone impair different aspects of beta-cell function in healthy men. *Eur J Endocrinol.* 2010;162:729–35.

- van Raalte DH, Brands M, van der Zijl NJ, et al. Low-dose glucocorticoid treatment affects multiple aspects of intermediary metabolism in healthy humans: a randomised controlled trial. *Diabetologia*. 2011a;54:2103–12.
- van Raalte DH, van Genugten RE, Linssen MM, et al. Glucagon-like peptide-1 receptor agonist treatment prevents glucocorticoid-induced glucose intolerance and islet-cell dysfunction in humans. *Diabetes Care*. 2011b;34:412–7.
- van Raalte DH, Diamant M, Ouwens DM, et al. Glucocorticoid treatment impairs microvascular function in healthy men in association with its adverse effects on glucose metabolism and blood pressure: a randomised controlled trial. *Diabetologia*. 2013a;56:2383–91.
- van Raalte DH, Kwa KA, van Genugten RE, et al. Islet-cell dysfunction induced by glucocorticoid treatment: potential role for altered sympathovagal balance? *Metabolism*. 2013b;62:568–77.
- Vegiopoulos A, Herzig S. Glucocorticoids, metabolism and metabolic diseases. *Mol Cell Endocrinol*. 2007;275:43–61.
- Verdecchia P, Reboldi G, Angeli F, et al. Adverse prognostic significance of new diabetes in treated hypertensive subjects. *Hypertension*. 2004;43:963–9.
- Verrotti A, Manco R, Agostinelli S, et al. The metabolic syndrome in overweight epileptic patients treated with valproic acid. *Epilepsia*. 2010;51:268–73.
- Vyas AK, Koster JC, Tzekov A, et al. Effects of the HIV protease inhibitor ritonavir on GLUT4 knock-out mice. *J Biol Chem*. 2010;285(47):36395–400.
- Wajngot A, Giacca A, Grill V, et al. The diabetogenic effects of glucocorticoids are more pronounced in low- than in high-insulin responders. *Proc Natl Acad Sci U S A*. 1992;89:6035–9.
- Waters DD, Ho JE, Boekholdt SM, et al. Cardiovascular event reduction versus new-onset diabetes during atorvastatin therapy. *J Am Coll Cardiol*. 2013;61:148–52.
- Winter WE, Funahashi M, Koons J. Encainide-induced diabetes: analysis of islet cell function. *Res Commun Chem Pathol Pharmacol*. 1992;76(3):259–68.
- Wise JK, Hendler R, Felig P. Influence of glucocorticoids on glucagon secretion and plasma amino acid concentrations in man. *J Clin Invest*. 1973;52:2774–82.
- Wollheim CB, Kikuchi M, Renold AE, Sharp GW. The roles of intracellular and extracellular Ca<sup>++</sup> in glucose-stimulated biphasic insulin release by rat islets. *J Clin Investig*. 1978;62(2):451–8.
- Yamagishi S, Inagaki Y, Nakamura K, et al. Azelnidipine, a newly developed long-acting calcium antagonist, inhibits tumor necrosis factor-alpha-induced interleukin-8 expression in endothelial cells through its anti-oxidative properties. *J Cardiovasc Pharmacol*. 2004;43(5):724–30.
- Yamazaki M, Sato A, Takeda T, et al. Distinct clinical courses in type 1 diabetes mellitus induced by peg-interferon-alpha treatment for chronic hepatitis C. *Intern Med*. 2010;49(5):403–7.
- Yang Y, Wei RB, Xing Y, et al. A meta-analysis of the effect of angiotensin receptor blockers and calcium channel blockers on blood pressure, glycemia and the HOMA-IR index in non-diabetic patients. *Metabolism*. 2013;62(12):1858–66.
- Yatham LN, Kennedy SH, Parikh SV, et al. Canadian Network for Mood and Anxiety Treatments (CANMAT) and International Society for Bipolar Disorders (ISBD) collaborative update of CANMAT guidelines for the management of patients with bipolar disorder: update 2013. *Bipolar Disord*. 2013;15(1):1–44.
- Yildirim SV, Azak E, Varan B, et al. Unusual and early hyperglycemia following amiodarone infusion in two infants. *Pediatr Cardiol*. 2005;26(5):715–6.
- Zhang R, Packard BA, Tauchi M, et al. Glucocorticoid regulation of preproglucagon transcription and RNA stability during stress. *Proc Natl Acad Sci U S A*. 2009;106:5913–8.



# Diabetes Secondary to Endocrine Disorders and PCOS 19

Paolo Moghetti

## Contents

Introduction .....	576
Diabetes Secondary to Hypersecretion of Counterregulatory Hormones .....	577
Glucagonoma .....	578
Pheochromocytoma .....	579
Cushing's Syndrome .....	580
Acromegaly .....	581
Other Endocrine Disorders Associated with Diabetes .....	582
Somatostatinoma .....	582
Thyroid Dysfunction .....	582
Hyperaldosteronism .....	583
Hyperparathyroidism .....	584
Male Hypogonadism .....	584
Polycystic Ovary Syndrome and Diabetes .....	585
Summary .....	590
References .....	591

## Abstract

A number of hormones participate physiologically in the regulation of blood glucose levels, and alterations in their production may cause hyperglycemia. In particular, hormones involved in the counterregulatory response to insulin, such as glucagon, catecholamines, cortisol, or GH, have a potent hyperglycemic action. Although abnormal overproduction of these hormones is rare, these forms of secondary diabetes should be recognized because they merit specific treatments and can even be cured by appropriate management. Exogenous glucocorticoid excess is a more common cause of iatrogenic secondary diabetes, which

---

P. Moghetti (✉)

Unit of Endocrinology, Diabetes and Metabolism, Department of Medicine, University of Verona and Azienda Ospedaliera Universitaria Integrata Verona, Verona, Italy

e-mail: [paolo.moghetti@univr.it](mailto:paolo.moghetti@univr.it)

may especially occur in subjects who have risk factors for type 2 diabetes. Somatostatin-secreting tumors, which are very rare, may also cause hyperglycemia, due to inhibition of insulin secretion. Similarly, treatment of some endocrine disorders by somatostatin analogs, particularly pasireotide, may induce hyperglycemia and secondary diabetes. Moreover, several other hormones modulate metabolic processes, with potential alterations of glucose levels in the case of abnormalities in their production. In particular, thyroid hormones regulate several steps of the glucose metabolism, with increased supply of glucose to tissues. In physiological conditions, these effects allow the body to meet the increased energy demand induced by thyroid hormones. However, thyroid dysfunction, especially hyperthyroidism, is associated with frequent alteration of glucose tolerance, with complex interactions with insulin action. There is evidence that sex hormones, by mechanisms that are still not completely understood, may also affect metabolic processes, including impaired insulin sensitivity. In particular, abnormalities in serum androgens are frequently associated with altered glucose levels. In this regard, there is a striking sexual dimorphism, as glucose intolerance is associated with reduced serum testosterone in men but with increased serum testosterone in women. This latter phenomenon may be especially found in women with polycystic ovary syndrome (PCOS), who are often insulin resistant. However, PCOS is a heterogeneous condition. Distinguishing the different clinical phenotypes of this syndrome is helpful in estimating the individual risk of metabolic abnormalities of these subjects.

---

**Keywords**

Diabetes · Secondary diabetes · Counterregulatory hormones · Glucagonoma · Pheochromocytoma · Acromegaly · Cushing's syndrome · Thyroid dysfunction · Polycystic ovary syndrome

---

**Introduction**

Blood glucose is strictly regulated by the coordinate action of a series of hormones, which physiologically maintain it in a narrow range. This tight regulation is crucial in order to ensure a constant, adequate supply of this fundamental energetic substrate to tissues, despite the wide variations occurring throughout the day in food ingestion and glucose consumption. While insulin plays a central role in the regulation of blood glucose, which is lowered through increased utilization by several tissues and reduced endogenous production, mainly by the liver, several “counterregulatory” hormones, such as glucagon, cortisol, catecholamines, and GH, cooperate in contrasting this action of insulin, favoring a balanced increase of glycemia. A failure in this fine regulation may cause chronically high glucose levels, or even overt diabetes mellitus. Considering the mechanisms that underlie glucose control, it is not surprising that this common metabolic alteration may be due to either impaired secretion and/or action of insulin or abnormally high levels of counterregulatory hormones.

**Table 1** Sites of action of the main hormones involved in diabetes secondary to endocrine disorders

	Insulin secretion	Glucose production	Glucose utilization	Lipolysis
<b>Glucagon</b>	+	+	/	/+
<b>Catecholamines</b>	–	+	–	+
<b>Cortisol</b>	+	+	–	+
<b>Growth hormone</b>	+	+	–	+
<b>Somatostatin</b>	–	/	/	/
<b>Thyroid hormones</b>	–	+	/–	+
<b>Aldosterone</b>	–	+	–	/

+, stimulation; –, inhibition; /, no effects

A primitive defect in insulin secretion and/or action is involved in the most common forms of diabetes mellitus, i.e., type 1 diabetes and type 2 diabetes, which are discussed in detail elsewhere in the textbook. Conversely, heterogeneous mechanisms account for several forms of diabetes “secondary” to other conditions. In this chapter the forms of diabetes secondary to the endocrine causes will be discussed. Table 1 summarizes the site of action of the main hormones involved in these alterations. In particular, these forms primarily include hypersecretion of counterregulatory hormones. However, other hormones play direct and/or indirect roles in the regulation of glucose metabolism, and alterations in their secretion may also cause hyperglycemia. Finally, an increased risk of diabetes is a feature of polycystic ovary syndrome (PCOS), a very common and heterogeneous endocrine disorder, through only partially understood mechanisms. These clinical conditions and their association with diabetes will also be discussed in the chapter.

## Diabetes Secondary to Hypersecretion of Counterregulatory Hormones

Glucose counterregulation indicates the whole set of mechanisms protecting the body against development of hypoglycemia and restoring euglycemia whenever hypoglycemia should occur. Counterregulation to hypoglycemia is fundamental for survival, and therefore it is not surprising that it is a fine-tuned process, characterized by seemingly redundant responses. Indeed, several endocrine adaptations participate in this phenomenon, including suppression of insulin secretion and increased production of several hormones capable of raising blood glucose levels. This redundancy makes that a deficiency in any glucose counterregulatory hormone can be compensated, at least in part, by the responses of other hormones, generally avoiding hypoglycemia. However, the mechanisms involved and the latency in the action of each specific hormone differ (Bolli and Fanelli 1999). Therefore, in the presence of any defective response, the intervention of other hormones cannot be viewed as a simple replacement but rather as an adaptive, integrated process.



In particular, glucagon is the most direct counterpart of insulin with its main effects in the liver, increasing endogenous glucose production through both glycogenolysis and gluconeogenesis. In addition, glucagon has a small effect of enhancing lipolysis in adipose tissue, which may become more evident when glucagon concentrations are very high. The action of glucagon is very rapid, occurring within minutes, and this hormone represents a key mechanism in the response to acute hypoglycemia.

The effects of catecholamines on glucose counterregulation are also very rapid and result from several mechanisms occurring at different sites. The effects of catecholamines include direct stimulation of glucose production, reduction of peripheral sensitivity to insulin, and stimulation of lipolysis in adipose tissue, which offers an alternative substrate for several tissues. Catecholamines produced by the adrenal medulla are the endocrine effector arm of the sympathetic nervous system, which is fundamental in coordinating body adaptation to any homeostasis change. Thus, their action also ensures strict control over the whole process, including regulation of the secretion of all participating hormones.

Cortisol acts principally in the muscle, stimulating protein catabolism and release of amino acids into the circulation, which can be subsequently used in the liver for gluconeogenesis. In addition, this hormone stimulates the release of free fatty acids from adipose tissue and impairs tissue insulin action.

Finally, the GH effect in glucose counterregulation is mainly related to reduced glucose utilization in insulin-dependent tissues. This hormone also stimulates lipolysis and protein synthesis and impairs tissue sensitivity to insulin action.

Notably, the lipolytic action of many hormones involved in this process has major effects on glucose metabolism. In this regard, there is competition for oxidation between glucose and fatty acids. Increased fatty acid availability favors hyperglycemia by both impairing muscle glucose utilization and by enhancing hepatic glucose production (Boden 1997).

In accordance with the physiological effects of counterregulatory hormones, a pathological chronic excess of any of them may cause hyperglycemia, i.e., secondary diabetes. Indeed, increased blood glucose is typically part of the syndromes observed in the presence of tumors producing these hormones. Although, in absolute terms, diabetes accompanying these heterogeneous syndromes is quite rare, it is important that these conditions are recognized, because hyperglycemia may possibly be reversed by specific treatments, in particular, by removal of the underlying tumor.

## Glucagonoma

Glucagonoma is an extremely rare tumor, with an estimated incidence of 0.01–0.1 cases per 100,000 persons per year and a peak in the fifth decade. It is generally pancreatic in origin and may be sporadic or, even more rarely, part of a multiple endocrine neoplasia type 1 (MEN1) syndrome. However, it is a rare component of this genetic syndrome, occurring in only 3% of cases. Most diagnosed cases are malignant and often metastatic by the time of diagnosis. The most typical

presentation is a migratory necrolytic erythema, which is a raised skin rash with irregular borders and occasionally bullae and crusts, in a subject with mild diabetes. The skin lesion has an unclear pathogenesis and can involve different body areas, especially the perineum, legs, and perioral area. This hormonal syndrome reflects the effects of glucagon and other products of proglucagon processing into the tumor and may differ according to the specific profile of these products. It includes, besides hyperglycemia and skin lesions, weight loss, anemia, stomatitis, and a series of heterogeneous intestinal complaints, such as abdominal pain, decelerated intestinal transit, diarrhea, or obstructive symptoms. Fasting hyperglycemia or overt diabetes may be recognized in about 80% of cases (van Beek et al. 2004). Diagnosis of glucagonoma generally relies on the measurement of glucagon levels, which can be extremely high, and a demonstration of a pancreatic mass in a subject with the typical syndrome.

### **Pheochromocytoma**

Pheochromocytoma is an uncommon tumor, with an estimated incidence of 0.2–0.8 cases per 100,000 persons per year. However, its frequency is underestimated, and diagnosis may be an incidental finding during autopsy. The prevalence among hypertensive patients is 0.2–0.6%, while it is approximately 5% among subjects with adrenal incidentalomas, i.e., those individuals who have an incidentally discovered adrenal mass. Catecholamine-secreting tumors may originate from the adrenal medulla or, less frequently, the sympathetic ganglia (paragangliomas). These lesions differ in terms of malignancy risk, which is about 10% for adrenal pheochromocytomas, whereas it is higher for extra-adrenal paragangliomas, and other aspects. At least one-third of these tumors originate from inherited mutations. In this regard, there are several distinct familial forms of catecholamine-secreting tumors, including MEN2 and von Hippel-Lindau syndrome. The peak of incidence is in the fourth to fifth decade, without differences between sexes, but these tumors often occur at a younger age in hereditary forms. Familial forms are also more frequent in subjects with bilateral or multifocal lesions. Due to the multiple effects of these hormones on several systems, clinical signs of catecholamine excess are extremely various, and diagnosis may be challenging. The syndrome may be characterized by typical sudden paroxysms, with hypertensive crisis, anxiety, chest pain, and a sensation of impending death, sometimes mimicking a heart attack. Palpitation, pallor, profuse sweating, and headache are other common complaints in these occasions. However, clinical manifestations are more often chronic and less specific. They frequently include sustained hypertension, although increased blood pressure is not mandatory, and there may even be orthostatic hypotension. Hyperglycemia is another common finding, usually mild to moderate in severity, related to catecholamine-induced impairment of both insulin secretion and insulin action. Epidemiological data on the prevalence of diabetes in these patients are extremely limited. They suggest that diabetes may occur in 33–50% of these subjects (Werbel and Ober 1995). Because epinephrine has more pronounced effects on glucose metabolism than

norepinephrine, hyperglycemia is more typical of adrenal tumors, which generally produce this hormone.

## Cushing's Syndrome

Cushing's syndrome is a complex clinical condition caused by either endogenous or exogenous glucocorticoid excess. Endogenous hormone excess is uncommon and may be due to heterogeneous etiologies, especially abnormal adrenal stimulation by pituitary or ectopic ACTH-secreting tumors or autonomous hormone production by a primitive adrenal adenoma or carcinoma. Even more rarely, the causes may also be ACTH hypersecretion induced by CRH-secreting tumors or aberrant adrenal receptor expression with stimulation of cortisol secretion by other hormones, such as GIP (gastric inhibitory polypeptide) or LH (luteinizing hormone). Chronic assumption of exogenous steroids can also, more frequently, cause this syndrome.

A pituitary ACTH-secreting tumor (i.e., Cushing's disease) is the most common cause of endogenous glucocorticoid excess. This tumor accounts for about 85% of non-iatrogenic cases of the syndrome, with an estimated incidence of 0.5–1 cases per 100,000 persons per year and a female/male ratio of about 4. However, mild cases may remain undiagnosed.

The clinical manifestations of Cushing's syndrome include centripetal body fat accumulation, with some typical aspects such as moon facies, buffalo hump, and supraclavicular depots; skin thinning, with plethora, striae rubrae, and easy bruising; loss of muscle mass and physical capacity; osteoporosis and bone fractures; hypertension; and hirsutism and menstrual dysfunction in females. Psychiatric abnormalities are also common in these patients, especially depression but occasionally overt psychosis. Skin hyperpigmentation may occur in the ACTH-dependent forms, especially in the presence of ectopic tumors, which are often associated with very high plasma ACTH levels. Hypokalemia is uncommon in these subjects, but it may be occasionally severe, especially in patients with ectopic tumors and marked hormone overproduction. Hyperglycemia is a common finding in these patients, and data from epidemiological studies suggest that diabetes may occur in 20–50% of them (Feelders et al. 2012). Due to the marked effects of glucocorticoids on insulin action, insulin resistance is a hallmark of this form of secondary diabetes. Interestingly, in recent years growing evidence has raised interest on the so-called subclinical Cushing's syndrome, i.e., a condition of mild autonomous glucocorticoid production, in which the most typical features of the syndrome are missing. Indeed, in these subjects the progression to overt Cushing's syndrome appears to be uncommon, whereas the effect of cortisol on fat distribution and metabolic features can mimic very common conditions, such as metabolic syndrome and type 2 diabetes (Feelders et al. 2012). Some authors have hypothesized that patients with these conditions should be systematically screened for subclinical Cushing's syndrome. However, available evidence indicates that this procedure would not be cost-effective, and current recommendations from the main scientific societies of the field suggest that screening should be limited to selected cases.

## Acromegaly

Acromegaly is another very rare disease, caused in the vast majority of cases by a GH-secreting pituitary tumor. The estimated incidence of these tumors is 0.3–1.1 per 100,000 persons per year, similar in both sexes and with a peak at 40–60 years. The most typical clinical manifestations of acromegaly are facial and acral somatic changes, due to the effects of the GH-IGF-1 system on the bone and soft tissues. The slow changes in these features mean that diagnosis is often made late in the course of the disease, with an average estimated lag of about 8–10 years. To obviate this delay, a screening by measurement of IGF-1 may be recommended in patients without the classical manifestations of acromegaly, when they show several of the nonspecific features frequently associated with the disease, particularly type 2 diabetes mellitus, hypertension, sleep apnea syndrome, debilitating arthritis, carpal tunnel syndrome, and hyperhidrosis. Although epidemiological data are limited, it can be estimated from the largest available studies that diabetes may occur in 20–40% of patients (Fieffe et al. 2011; Dal et al. 2016). Age, disease duration, and BMI are risk factors for hyperglycemia associated with this condition. Also in this form of secondary diabetes, insulin resistance is a predominant feature. Beta cell failure may also be observed in advanced stages of the disease. However, this does not appear to be due to excess GH, as this hormone has a direct stimulatory effect on beta cell mass and function. In this regard, it is noteworthy that subjects with isolated GH deficiency show an impaired insulin response to stimulation and have an increased risk of glucose intolerance. In adults with GH deficiency, metabolic abnormalities may be also due to concurrent alterations in insulin action, likely due to increased adiposity, reduced muscle mass, and impaired physical performance (Møller and Jørgensen 2009).

Some tumors may show plurihormonal secretion. In these extremely rare tumors, clinical syndromes result from the involved hormones, which can potentially cooperate in causing secondary diabetes. In particular, co-secretion of catecholamines and ACTH, or GH and ACTH, has been occasionally reported.

Secondary diabetes may be typically reversed by treatment of the underlying conditions. However, cure of these tumors is not always possible, and some pharmacological therapies used for controlling hormone secretion or hormone action may in turn have an adverse effect on glucose metabolism. In particular, this is the case of somatostatin analogs and principally of pasireotide (Silverstein 2016). This latter is a new-generation somatostatin analog recently approved for the treatment of pituitary Cushing's disease and acromegaly, especially when they cannot be cured by surgery and are non-adequately responsive to other medications. Pasireotide has a broader spectrum of action on somatostatin receptors, as compared with the oldest drugs in the class, octreotide and lanreotide, showing high binding affinity for sst1, sst2, sst3, and sst5 subtypes of the receptor. This translates into greater efficacy in the treatment of hormone hypersecretion but also in a more pronounced inhibitory effect on pancreatic beta cell secretion. Therefore hyperglycemia is a more common side effect with this medication.

## Other Endocrine Disorders Associated with Diabetes

### Somatostatinoma

Somatostatinoma is an extremely rare tumor, which generally develops in the pancreas or the duodenum. Somatostatin inhibits, physiologically, many gastrointestinal functions and the secretion of several gastrointestinal hormones, including insulin. As a consequence, hyperglycemia is an expected finding when there is abnormal secretion of this hormone. Indeed, diabetes, although usually mild, is a feature of the somatostatinoma syndrome (Krejs et al. 1979), along with steatorrhea, cholelithiasis, and a number of less specific symptoms, such as weight loss, abdominal pain, obstructive symptoms, and hypochlorhydria. These tumors are frequently malignant and metastatic at diagnosis. Pancreatic somatostatinomas are generally sporadic, whereas they are rarely associated with the MEN1 syndrome. Duodenal tumors may be associated with neurofibromatosis type 1 or von Hippel-Lindau syndrome, occasionally in combination with pheochromocytomas. Diagnosis of somatostatinomas is based on the measurement of somatostatin levels, when available, and abdominal imaging. Alternatively, it may be a histological finding.

### Thyroid Dysfunction

Thyroid dysfunction includes a group of very frequent endocrine disorders, with either increased or reduced thyroid hormone secretion. Although diabetes is not considered a typical hallmark of these pathologies, the metabolic abnormalities associated with thyroid dysfunction are important in clinical practice, due to the high frequency of these disorders, which may frequently remain undiagnosed.

Both thyroid hormone excess and deficiency can affect glucose metabolism. In particular, overt hyperthyroidism is frequently associated with alterations of glucose tolerance. This condition is generally caused by autoimmune Graves' disease or toxic nodular goiter, whereas other causes are uncommon. The estimated prevalence of overt hyperthyroidism in Europe and the USA is about 0.5%. Hypothyroidism is more often caused by chronic autoimmune thyroiditis, but there are several other potential causes; overt hypothyroidism as well has a high prevalence, which increases with age. Both hyperthyroidism and hypothyroidism occur more frequently in women than in men.

Thyroid hormones exert multiple metabolic actions, including regulation of several steps of glucose metabolism (Potenza et al. 2009). They directly stimulate both glycogenolysis and gluconeogenesis, thus increasing the supply of glucose to tissues, which is required to meet the higher energy demands that these hormones generate. When this physiological phenomenon is abnormally enhanced by thyroid hormone excess, glucose tolerance may be altered, despite the fact that these hormones also increase glucose utilization. Thyroid hormones reduce insulin action in the liver, while they have complex effects on peripheral insulin action. In this regard, they stimulate the oxidative metabolism of glucose on one hand but impair

glycogen synthesis and increase lipolysis on the other hand. The resulting increase in free fatty acid concentrations contributes to the impaired insulin action. It is noteworthy that, due to the specific mechanisms involved, interaction between thyroid hormones and insulin action appears to be influenced by the prevailing glucose concentrations. In particular, in hyperthyroid subjects, insulin sensitivity may be normal at basal glucose levels but clearly impaired during hyperglycemia (Müller et al. 1986). In this context, alterations of glucose tolerance may also be favored by higher intestinal absorption of glucose, as well as by increased glucagon secretion, reduced insulin secretion, and accelerated insulin catabolism, which are all induced by thyroid hormone excess (Mullur et al. 2014). Against this background, it is difficult to estimate the frequency of diabetes in hyperthyroid patients. Limited data indicate that at least one-third of these patients may have glucose intolerance (Lenzen and Bailey 1984). However, this figure is affected by the severity of thyroid hormone excess. In subjects with preexisting insulin-treated diabetes, insulin requirement typically increases, and in patients with type 1 diabetes, hyperthyroidism may precipitate a ketoacidosis. In this regard, it should be noted that the co-occurrence of both type 1 diabetes and autoimmune thyroid diseases, including Graves' disease, in a single individual is one of the variants of the autoimmune polyglandular syndrome type 3 (Huber et al. 2008).

The relationship between hypothyroidism and the alteration of glucose metabolism has been less investigated. Hypothyroidism is characterized by decreased energy expenditure and substrate utilization. Moreover, some studies indicated that insulin resistance may be a feature of overt hypothyroidism (Dimitriadis et al. 2006). However, data on glucose tolerance are limited, with mixed results. In subjects with preexisting insulin-treated diabetes, exogenous insulin catabolism is reduced, and insulin requirement may be lower.

Recent studies suggest that lower thyroid function, even within the normal range, may predict incident type 2 diabetes (Chaker et al. 2016). Available information also indicates that patients with type 2 diabetes are more likely to have subclinical hypothyroidism (i.e., slightly increased serum TSH with normal levels of thyroid hormones), when compared with healthy subjects (Han et al. 2015). Similar findings have been more recently reported in women with gestational diabetes. However, the meaning of these observations remains controversial. TSH levels may increase in subjects with body fat excess, and adaptive mechanisms could be involved in this phenomenon. Therefore a mild increase in TSH levels does not necessarily indicate a true subclinical hypothyroidism. Nonetheless, it was reported that among women with increased TSH, only those with thyroid autoantibodies may have an increased risk of gestational diabetes (Karakosta et al. 2012).

## Hyperaldosteronism

Other hormones can potentially affect glucose metabolism, favoring hyperglycemia. Interestingly, an increased risk of diabetes in patients with hyperaldosteronism was originally reported in the first studies on this condition, and recent research showed

that frequency of diabetes is about twice in patients with hyperaldosteronism, as compared with subjects with essential hypertension, with similar or even higher BMI (Remde et al. 2015). Multiple mechanisms appear to be involved in this relationship, including mineralocorticoid receptor-mediated insulin resistance and impaired insulin secretion (Luther 2014). Aldosterone-induced hypokalemia may participate in this phenomenon, impairing insulin secretion. However, correction of hypokalemia only partially restores these alterations. Aldosterone per se seems to impair glucose-stimulated insulin secretion in isolated pancreatic beta cells, at least in part via reactive oxygen species overproduction. Moreover, cross-sectional studies showed that plasma aldosterone levels are higher in patients with insulin resistance and can predict incident insulin resistance in nondiabetic subjects (Kumagai et al. 2011). In animal models, excess aldosterone provoked glucose intolerance in a dose-dependent manner as a result of impaired insulin signaling, with downregulation of insulin receptor substrate-1 (IRS-1) and the downstream phosphatidylinositol 3-kinase/AKT pathway (Selvaraj et al. 2013), leading to decreased glucose uptake and oxidation in skeletal muscle and adipocytes. Moreover, aldosterone may increase hepatic glucose production by inducing gluconeogenic enzymes in the liver.

## Hyperparathyroidism

Available evidence indicates that the frequency of diabetes mellitus in subjects with primary hyperparathyroidism and the frequency of primary hyperparathyroidism in diabetic patients are both approximately three times higher than the expected values in the age-matched general population (Taylor and Khaleeli 2001). In addition, several studies have shown that primary hyperparathyroidism is characterized by impaired insulin action (Procopio et al. 2002). These metabolic alterations may rapidly improve after parathyroidectomy, suggesting a direct relationship with the endocrine disorder. Both hypercalcemia and hypophosphatemia, which are typical features of overt primary hyperparathyroidism, may concur in this phenomenon. However, there is evidence that, besides its classical actions on the bone and kidney, PTH has direct metabolic effects. In accordance with this observation, metabolic abnormalities are also seen in secondary hyperparathyroidism. Moreover, in the general population, higher PTH concentrations are associated with increased risk of cardiovascular events and mortality. Interestingly, in animal models of secondary hyperparathyroidism, glucose intolerance did not develop in the absence of PTH, whereas the presence of this hormone was associated with impaired insulin secretion (Akmal et al. 1985). Moreover, recent *in vitro* studies demonstrated that, in adipocytes, PTH may directly impair insulin signaling and stimulate lipolysis.

## Male Hypogonadism

An increased risk of diabetes is also a characteristic of patients with male hypogonadism, such as those with Klinefelter syndrome (Salzano et al. 2016).

Interestingly, subjects with late-onset hypogonadism typically show obesity and several metabolic alterations that are associated with altered insulin action, suggesting a link between androgen deficiency and insulin resistance in men. Moreover, patients with type 2 diabetes show lower serum testosterone levels and a higher prevalence of clinical features of hypogonadism than age-matched non-diabetic controls (Corona et al. 2011). Recent research that has assessed the metabolic effects of androgen supplementation in hypogonadal men showed that in these subjects, testosterone replacement was associated with a reduction in fasting blood glucose, suggesting a beneficial cardiometabolic effect of treatment (Grossmann 2014). However, results are controversial and in some studies where patients with hypogonadism were given high-dose testosterone, an increased risk of cardiovascular events was reported. Current guidelines on this topic recommend that management of aging men with late-onset hypogonadism should include individual careful evaluation of risk versus benefit assessment, while testosterone replacement should be offered to these subjects only if a combination of symptoms of testosterone deficiency and biochemical evidence of low serum testosterone is observed (Dimopoulou et al. 2016). Overall, data on these issues are still limited, and further research is needed.

Interestingly, these findings in men strikingly differ from those in women, in whom metabolic alterations are rather associated with androgen excess, as discussed in detail in the subsequent section. The mechanisms underlying this noticeable sexual dimorphism are still largely unknown.

---

## Polycystic Ovary Syndrome and Diabetes

PCOS is a very common endocrine disorder of women in the reproductive age. However, the small number of epidemiologic studies carried out, the frequent inaccuracies and intrinsic limitations in measures used for diagnosis, and the differences among studies in diagnostic criteria adopted make it difficult to reliably approximate the true prevalence of this condition. At present, the most widely used diagnostic criteria are those recommended by a joint consensus workshop of the European Society of Human Reproduction and Embryology (ESHRE) and the American Society for Reproductive Medicine (ASRM), held in Rotterdam in 2003 (Rotterdam ESHRE/ASRM-Sponsored PCOS consensus workshop group 2004). For this reason they are commonly referred to as the Rotterdam criteria. According to these criteria, PCOS may be diagnosed by the presence of at least two of three key clinical features: hyperandrogenism (clinical and/or biochemical), chronic oligoanovulation, and polycystic ovarian morphology (PCOM). Nonetheless, diagnosis needs preliminary exclusion of potential secondary causes, such as congenital adrenal hyperplasia, hyperprolactinemia, thyroid dysfunction, or androgen-secreting tumors. By using the Rotterdam criteria, up to 18–20% of women may have PCOS, a figure substantially greater than the previously estimated 6–8% (Lizneva et al. 2016). Another important point is that this condition is heterogeneous. In this regard, adoption of the Rotterdam criteria has determined that



different clinical phenotypes were included under the same diagnosis of PCOS. These phenotypes are generally named classic (corresponding to the previous definition of the syndrome and characterized by both hyperandrogenism and oligoanovulation, with or without PCOM), ovulatory (hyperandrogenism and PCOM), and normoandrogenic (oligoanovulation and PCOM). This phenotypic distinction is important, as it implies several clinically important differences. In particular, there is a scale of metabolic risk between PCOS phenotypes. Indeed, the impairment of insulin action is a characteristic of subjects with the classic phenotype but not of subjects with the normoandrogenic phenotype, who generally have normal insulin sensitivity, whereas those with the ovulatory phenotype show intermediate metabolic characteristics (Moghetti et al. 2013). A similar scale exists in terms of frequency of metabolic syndrome and other metabolic abnormalities.

The etiology of PCOS remains unknown and is possibly multifactorial, with evidence of involvement of both genetic and environmental factors.

Insulin resistance is considered a typical feature of women with PCOS, and consistent evidence indicates that it plays a major role in these subjects on several grounds (Diamanti-Kandarakis and Dunaif 2012). In particular, it appears to be a key pathogenic mechanism of PCOS itself, primarily through the effects of associated hyperinsulinemia. In this regard, there is experimental proof that insulin excess may enhance androgen biosynthesis in both the ovary and the adrenal. Interestingly, in animal models, selective knockdown of the insulin receptor in theca cells almost completely abolished both the reproductive and the endocrine abnormalities associated with diet-induced obesity and hyperinsulinemia (Wu et al. 2014). Moreover, hyperinsulinemia also inhibits sex hormone binding globulin production in the liver, thus increasing free, bioavailable testosterone.

The impairment in insulin action may also favor the metabolic abnormalities commonly found in these women, including increased risk of type 2 diabetes. There is evidence of familial traits associated with PCOS, particularly hyperandrogenism, which appear to occur with increased frequency in mothers, sisters, and daughters of women with this condition. Other common traits in these families are hyperinsulinemia and obesity, which were found with increased frequency in both female and male relatives of women with PCOS (Legro et al. 1998; Sam et al. 2008). Collectively, these findings suggest a genetic susceptibility to insulin resistance, which may track with androgen excess in patients with PCOS and their female relatives.

It was hypothesized that there may be some specific abnormality responsible for the impairment of insulin action in PCOS. In particular, it was reported that in cultured cells obtained from a small sample of PCOS women, there was an increased serine phosphorylation and reduced tyrosine phosphorylation of the insulin receptor, with impaired tyrosine kinase activity of the receptor. This phenomenon may be responsible for impaired insulin signaling. However, in the same study, other insulin-resistant subjects with PCOS did not show this abnormality, suggesting heterogeneity in the mechanisms involved. At present, despite several subsequent studies, the specific mechanisms involved, if any, are unknown.

Despite the major role attributed to insulin resistance in this condition, the frequency of alterations in insulin sensitivity among subjects with PCOS has poorly been investigated and remains undetermined. Most available information was based on the measurement of surrogate indices of insulin action, and these studies indicated that up to 50–70% of PCOS subjects may be insulin resistant. In a study carried out in 137 women with PCOS referred to the outpatient clinic of an academic center, in which insulin sensitivity was assessed by the euglycemic clamp technique, the gold standard method for measuring *in vivo* insulin action, the frequency of insulin resistance was 71% (Moggetti et al. 2013). Notably, one-third of these young women, at a mean age of 23 years, also had metabolic syndrome. Nevertheless, there may be referral bias for several aspects of PCOS. In particular, there is evidence that women referred to medical centers may be more obese and more hyperandrogenic, as compared with unselected PCOS women identified through a screening carried out in the general population (Ezeh et al. 2013). Notably, in contrast with common clinical findings, unselected PCOS women appear to be similar to the background population in terms of mean BMI and frequency of obesity. These findings suggest that PCOS women referred for medical care may not be representative of the general population of subjects with PCOS. Rather, they may be a selected subgroup, with the most severe clinical features. To what extent these differences in terms of body weight, between referred and unselected people with PCOS, indicate differences in terms of insulin resistance and associated metabolic abnormalities cannot be estimated. However, body fat excess, especially truncal fat, is a strong predictor of insulin resistance also in these women (Tosi et al. 2015).

Insulin resistance is a key pathogenic factor for type 2 diabetes mellitus. In addition, beta cell dysfunction has been also demonstrated in women with PCOS. The resulting impairment in insulin secretion is of paramount importance for the development of hyperglycemia, because the compensatory mechanism of hyperinsulinemia cannot operate. Thus it could be expected that abnormalities of glucose metabolism may frequently occur in these women. Indeed, PCOS is considered a major risk factor for type 2 diabetes, although the literature on this issue is quite limited. Obviously, there are differences in this risk according to the ethnic and anthropometric characteristics of subjects. Nevertheless, a meta-analysis of studies that have compared the frequency of type 2 diabetes in PCOS women versus BMI-matched controls concluded that diabetes is four times more prevalent in PCOS women (Moran et al. 2010). Consistently, a few small prospective studies showed a higher conversion rate from normal to abnormal glucose tolerance in subjects with PCOS, as compared with controls. Overall, available data support the conclusion that PCOS status is an independent risk factor for diabetes development, while baseline obesity and weight gain over time enhance this risk. However, there are no large prospective studies on this issue, and the risk and protective factors for development of diabetes in these patients remain to be defined.

In a large nationwide population study carried out in Denmark, it was noticed that frequency of diabetes was about three times higher in women diagnosed with PCOS, as compared with the background population of the same age, whereas frequency of obesity was eight times higher in PCOS subjects (Glintborg et al. 2015). In

particular, in this study, the risk of diabetes was five times greater for type 2 diabetes. Notably, the risk of gestational diabetes and the risk of type 1 diabetes were also increased in these women, by four and two times, respectively. The concurrent increase in risk of type 2 diabetes and gestational diabetes may be expected, as these different forms of diabetes share to a large extent a key pathogenic mechanism, i.e., insulin resistance. Consistently, women with PCOS who had gestational diabetes also showed increased risk of persistence of abnormal glucose tolerance after pregnancy, as compared to women with a history of gestational diabetes not affected with PCOS. However, the association between PCOS and type 1 diabetes appears to reflect a different issue. This association is supported by evidence of increased frequency of all typical diagnostic features of PCOS, such as androgen excess and polycystic ovarian morphology, in young women with this form of diabetes (Escobar-Morreale and Roldán-Martín 2016). Indeed, a likely explanation for this phenomenon is iatrogenic peripheral hyperinsulinemia, which translates into increased exposure to insulin of the ovary. Consistent with this hypothesis is the observation that women with the simultaneous presence of both type 1 diabetes and PCOS do not show decreased SHBG serum levels, which, in contrast, is a common finding in classical PCOS. In this regard, reduction in SHBG concentrations is attributed to excess insulin action on the liver, which however does not occur when insulin is exogenous, as it is injected into subcutaneous tissue.

It could be also expected that PCOS may be found with increased frequency in women with type 2 diabetes. Although available information is in accordance with this hypothesis, data are extremely limited. Indeed, the older age of most patients who have developed type 2 diabetes may account for the difficulties in diagnosing a previous PCOS in these subjects. Moreover, it is noteworthy that this phenomenon may also reflect substantial delay in diagnosis of diabetes in subjects with PCOS, due to frequent late screening of metabolic abnormalities in these women. In actual fact, many patients with PCOS are not submitted to an OGTT, in contrast with the recommendations of the main scientific societies of both the endocrine and gynecological fields on this issue.

In this regard, there is general consensus that PCOS women should be screened for glucose tolerance abnormalities, especially when they have additional risk factors for diabetes, such as body fat excess, a family history of diabetes, or history of previous gestational diabetes. It is noteworthy that fasting blood glucose is still normal in many subjects with PCOS, even when they have impaired glucose tolerance or even diabetes (Fig. 1). Therefore, fasting glucose concentrations are of limited value for selecting the patients to screen for abnormalities in glucose tolerance. Similarly, sensitivity of HbA1c assay proved to be low in young women with PCOS, making this measurement suboptimal for screening glucose tolerance in these patients. Performing an OGTT is thus the recommended method for assessing glucose tolerance in subjects with PCOS.

Increased waist circumference and low serum HDL-cholesterol are other common findings in PCOS women, accounting for the striking increase in the frequency of metabolic syndrome reported by several studies in these subjects. The presence, at an early age, of multiple metabolic abnormalities suggested that these patients may

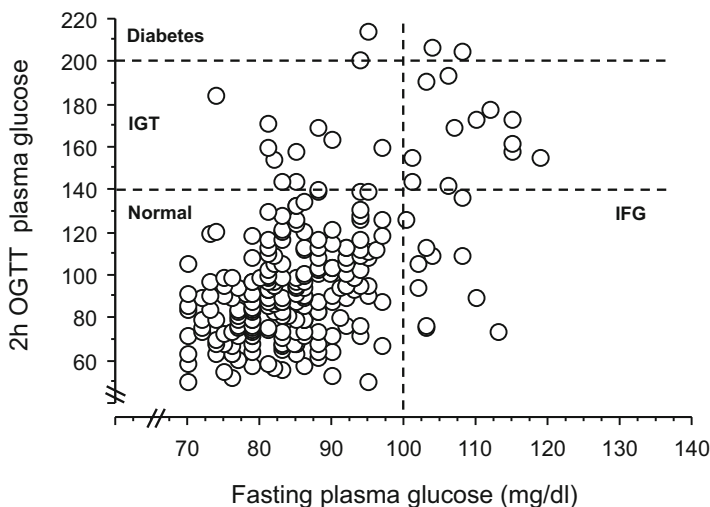

**Fig. 1** Relationship between fasting and 2 h plasma glucose levels during a 75 g oral glucose tolerance test in 243 women with PCOS recruited in the Verona 3P Study (for details on the study, see Moghetti et al. 2013). Notably, several subjects with impaired glucose tolerance, or even with diabetes, showed normal fasting glucose levels. This finding is consistent with previous reports in these women. *IGT* impaired glucose tolerance, *IFG* impaired fasting glucose

also have higher cardiovascular risk. Yet, the hypothesis that these alterations translate into increased frequency of cardiovascular events still lacks definite proof. In this regard, while a number of papers showed abnormalities in surrogate markers of atherosclerosis in subjects with PCOS, no clear, direct evidence of increased risk of cardiovascular events has yet been reported. Available data on this issue are still limited. However, it has been hypothesized that these subjects may also have some protective factors, counterbalancing the potential adverse effects of metabolic alterations. In this regard, androgens showed both pro-inflammatory and anti-inflammatory properties and factors influencing this balance remain poorly understood. Moreover, many typical features of PCOS, such as hyperandrogenemia and menstrual dysfunction, generally attenuate over time in the life span of these women. Indeed, the common assumption that hirsutism and reproductive alterations characterize the clinical picture of PCOS at an early age, while metabolic alterations and cardiovascular risk predominate at an older age, is unproven. Some data even indicate that insulin resistance, in parallel with androgen levels, may attenuate over time in these subjects, in contrast with findings in the general population.

Another potentially important issue is whether the different pharmacological agents used in the management of PCOS, in particular oral contraceptives, insulin sensitizers, and antiandrogens, may influence the risk of abnormalities of glucose tolerance in these women. Metformin is obviously expected to play a protective role from this point of view, according to its mechanisms of action and results

obtained in randomized controlled trials carried out in subjects at high risk for type 2 diabetes. However, specific information in PCOS women is lacking. Limited and controversial information suggests that antiandrogens might have some favorable effect, due to the improvement of insulin resistance. Finally, the role of oral contraceptives, which represent the medications most commonly used in these women, is still unclear. Limited short-term studies reported mixed results, likely due to differences in characteristics of patients and formulations used. While it is well known that pharmacological doses of estrogen may have adverse effects on insulin sensitivity, the expected concurrent improvement of hyperandrogenism could counterbalance this phenomenon in women with PCOS. Overall, although evidence-based information is extremely limited, when prescribing oral contraceptives for PCOS women, it may be advisable to reassess glucose tolerance after several months of treatment, especially in those patients who have additional risk factors for diabetes, such as body fat excess, and/or are given higher dose estrogens combined with cyproterone acetate (Moghetti et al. 2015). In the presence of severe obesity, combined oral contraceptives should be used only after judicious consideration of the advantages versus risks balance. However, for severely obese women, alternative contraceptive measures should be preferred, when needed.

According to the major role of lifestyle on insulin resistance and risk of type 2 diabetes, it is quite obvious that lifestyle interventions are considered a fundamental tool in the management of PCOS women, especially when they are overweight or obese. However, information on the effects of this strategy is limited and short term. In particular, no specific information is available on the efficacy of lifestyle intervention on the risk of diabetes for these women.

---

## Summary

Blood glucose levels are tightly regulated, and a number of hormones physiologically participate in this fundamental process. Alterations in the production of these hormones frequently cause altered glucose tolerance. In particular, hormones involved in the counterregulatory response to insulin, such as glucagon, catecholamines, cortisol, or GH, have a powerful hyperglycemic action. Although tumoral overproduction of these hormones is quite rare, these forms of secondary diabetes should be recognized because they warrant specific treatments, which can even cure the associated metabolic disorders. Exogenous glucocorticoid excess is a cause of iatrogenic diabetes, which especially occurs in subjects who have additional risk factors for type 2 diabetes. Somatostatin-secreting tumors, which are very rare, typically cause hyperglycemia, due to inhibition of insulin secretion. Similarly, treatment of some endocrine disorders, such as Cushing's disease or acromegaly, by somatostatin analogs, particularly pasireotide, may induce hyperglycemia and secondary diabetes. Additionally, several other hormones modulate the metabolic processes, with potential alterations in glucose levels, when there are abnormalities in their production. In particular, thyroid hormones regulate several steps of glucose

metabolism, favoring an increased supply of glucose to tissues. In physiological conditions, such effects allow the body to meet the increased energy demand induced by these hormones. However, thyroid dysfunction, especially hyperthyroidism, is frequently associated with alterations of glucose tolerance, with the contribution of complex interactions between thyroid hormones and insulin action. In this context, insulin sensitivity may be either normal or altered, according to the prevailing glucose concentrations. There is evidence that sex hormones may also affect metabolic processes, by mechanisms that are not completely understood, including altered insulin sensitivity. In particular, abnormalities in serum androgens are frequently associated with metabolic alterations. However, there is a striking sexual dimorphism, as glucose intolerance is associated with reduced serum testosterone in men, whereas it is associated with increased serum testosterone in women. This latter relationship is especially observed in women with PCOS, who are typically insulin resistant. However, PCOS is a heterogeneous condition, and the different clinical phenotypes of this syndrome show a scale of metabolic risk, making this distinction among PCOS subjects an important issue.

In conclusion, a number of hormones participate in the regulation of blood glucose levels. Alterations in the production of these hormones may cause secondary diabetes, and these forms should be recognized because they warrant specific treatments. Diabetes is also a relatively common finding in young women with PCOS. The mechanisms underlying this association are only partially understood, but it appears clear that they comprise hyperinsulinemia, which is typically associated with insulin resistance. The increased risk of metabolic alterations in women with PCOS requires that these subjects are periodically screened for glucose intolerance.

---

## References

- Akmal M, Massry SG, Goldstein DA, Fanti P, Weisz A, DeFronzo RA. Role of parathyroid hormone in the glucose intolerance of chronic renal failure. *J Clin Invest.* 1985;75(3):1037–44.
- Boden G. Role of fatty acids in the pathogenesis of insulin resistance and NIDDM. *Diabetes.* 1997;46(1):3–10.
- Bolli GB, Fanelli CG. Physiology of glucose counterregulation to hypoglycemia. *Endocrinol Metab Clin North Am.* 1999;28(3):467–93.
- Chaker L, Ligthart S, Korevaar TI, Hofman A, Franco OH, Peeters RP, et al. Thyroid function and risk of type 2 diabetes: a population-based prospective cohort study. *BMC Med.* 2016; 14(1):150.
- Corona G, Monami M, Rastrelli G, Aversa A, Sforza A, Lenzi A, et al. Type 2 diabetes mellitus and testosterone: a meta-analysis study. *Int J Androl.* 2011;34(6 Pt 1):528–40.
- Dal J, Feldt-Rasmussen U, Andersen M, Kristensen LØ, Laurberg P, Pedersen L, et al. Acromegaly incidence, prevalence, complications and long-term prognosis: a nationwide cohort study. *Eur J Endocrinol.* 2016;175(3):181–90.
- Diamanti-Kandarakis E, Dunaif A. Insulin resistance and the polycystic ovary syndrome revisited: an update on mechanisms and implications. *Endocr Rev.* 2012;33(6):981–1030.
- Dimitriadis G, Mitrou P, Lambadiari V, Boutati E, Maratou E, Panagiotakos DB, et al. Insulin action in adipose tissue and muscle in hypothyroidism. *J Clin Endocrinol Metab.* 2006;91(12):4930–7.

- Dimopoulou C, Ceausu I, Depypere H, Lambrinoukaki I, Mueck A, Pérez-López FR, et al. EMAS position statement: testosterone replacement therapy in the aging male. *Maturitas*. 2016;84:94–9.
- Escobar-Morreale HF, Roldán-Martín MB. Type 1 diabetes and polycystic ovary syndrome: systematic review and meta-analysis. *Diabetes Care*. 2016;39(4):639–48.
- Ezeh U, Yildiz BO, Azziz R. Referral bias in defining the phenotype and prevalence of obesity in polycystic ovary syndrome. *J Clin Endocrinol Metab*. 2013;98(6):E1088–96.
- Feeders RA, Pulgar SJ, Kempel A, Pereira AM. The burden of Cushing's disease: clinical and health-related quality of life aspects. *Eur J Endocrinol*. 2012;167(3):311–26.
- Fieffe S, Morange I, Petrossians P, Chanson P, Rohmer V, Cortet C, Borson-Chazot F, Brue T, Delemer B, French Acromegaly Registry. Diabetes in acromegaly, prevalence, risk factors, and evolution: data from the French Acromegaly Registry. *Eur J Endocrinol*. 2011;164(6):877–84.
- Glintborg D, Hass Rubin K, Nybo M, Abrahamsen B, Andersen M. Morbidity and medicine prescriptions in a nationwide Danish population of patients diagnosed with polycystic ovary syndrome. *Eur J Endocrinol*. 2015;172(5):627–38.
- Grossmann M. Testosterone and glucose metabolism in men: current concepts and controversies. *J Endocrinol*. 2014;220(3):R37–55.
- Han C, He X, Xia X, Li Y, Shi X, Shan Z, et al. Subclinical hypothyroidism and type 2 diabetes: a systematic review and meta-analysis. *PLoS One*. 2015;10(8):e0135233.
- Huber A, Menconi F, Corathers S, Jacobson EM, Tomer Y. Joint genetic susceptibility to type 1 diabetes and autoimmune thyroiditis: from epidemiology to mechanisms. *Endocr Rev*. 2008;29(6):697–725.
- Karakosta P, Alegakis D, Georgiou V, Roumeliotaki T, Fthenou E, Vassilaki M, et al. Thyroid dysfunction and autoantibodies in early pregnancy are associated with increased risk of gestational diabetes and adverse birth outcomes. *J Clin Endocrinol Metab*. 2012;97(12):4464–72.
- Krejs GJ, Orci L, Conlon JM, Ravazzola M, Davis GR, Raskin P, et al. Somatostatinoma syndrome. Biochemical, morphologic and clinical features. *N Engl J Med*. 1979;301(6):285–92.
- Kumagai E, Adachi H, Jacobs DR Jr, Hirai Y, Enomoto M, Fukami A, et al. Plasma aldosterone levels and development of insulin resistance: prospective study in a general population. *Hypertension*. 2011;58(6):1043–8.
- Legro RS, Driscoll D, Strauss JF 3rd, Fox J, Dunaif A. Evidence for a genetic basis for hyperandrogenemia in polycystic ovary syndrome. *Proc Natl Acad Sci USA*. 1998;95(25):14956–60.
- Lenzen S, Bailey CJ. Thyroid hormones, gonadal and adrenocortical steroids and the function of the islets of Langerhans. *Endocr Rev*. 1984;5(3):411–34.
- Lizneva D, Suturina L, Walker W, Brakta S, Gavrilova-Jordan L, Azziz R. Criteria, prevalence, and phenotypes of polycystic ovary syndrome. *Fertil Steril*. 2016;106(1):6–15.
- Luther JM. Effects of aldosterone on insulin sensitivity and secretion. *Steroids*. 2014;91:54–60.
- Moghetti P, Tosi F, Bonin C, Di Sarra D, Fiers T, Kaufman JM, et al. Divergences in insulin resistance between the different phenotypes of the polycystic ovary syndrome. *J Clin Endocrinol Metab*. 2013;98(4):E628–37.
- Moghetti P, Carmina E, De Leo V, Lanzone A, Orio F, Pasquali R, et al. How to manage the reproductive issues of PCOS: a 2015 integrated endocrinological and gynecological consensus statement of the Italian Society of Endocrinology. *J Endocrinol Invest*. 2015;38(9):1025–37.
- Møller N, Jørgensen JO. Effects of growth hormone on glucose, lipid, and protein metabolism in human subjects. *Endocr Rev*. 2009;30(2):152–77.
- Moran LJ, Misso ML, Wild RA, Norman RJ. Impaired glucose tolerance, type 2 diabetes and metabolic syndrome in polycystic ovary syndrome: a systematic review and meta-analysis. *Hum Reprod Update*. 2010;16(4):347–63.
- Müller MJ, von Schütz B, Huhnt HJ, Zick R, Mitzkat HJ, von zur Mühlen A. Glucoregulatory function of thyroid hormones: interaction with insulin depends on the prevailing glucose concentration. *J Clin Endocrinol Metab*. 1986;63(1):62–71.

- Mullur R, Liu YY, Brent GA. Thyroid hormone regulation of metabolism. *Physiol Rev.* 2014;94(2):355–82.
- Potenza M, Via MA, Yanagisawa RT. Excess thyroid hormones and glucose metabolism. *Endocr Pract.* 2009;15(3):254–62.
- Procopio M, Magro G, Cesario F, Piovesan A, Pia A, Molineri N, et al. The oral glucose tolerance test reveals a high frequency of both impaired glucose tolerance and undiagnosed type 2 diabetes mellitus in primary hyperparathyroidism. *Diabet Med.* 2002;19(11):958–61.
- Remde H, Hanslik G, Rayes N, Quinkler M. Glucose metabolism in primary aldosteronism. *Horm Metab Res.* 2015;47(13):987–93.
- Rotterdam ESHRE/ASRM-Sponsored PCOS consensus workshop group. Revised 2003 consensus on diagnostic criteria and long-term health risks related to polycystic ovary syndrome (PCOS). *Hum Reprod.* 2004;19(1):41–7.
- Salzano A, Arcopinto M, Marra AM, Bobbio E, Esposito D, Accardo G, et al. Klinefelter syndrome, cardiovascular system, and thromboembolic disease: review of literature and clinical perspectives. *Eur J Endocrinol.* 2016;175(1):R27–40.
- Sam S, Coviello AD, Sung YA, Legro RS, Dunaif A. Metabolic phenotype in the brothers of women with polycystic ovary syndrome. *Diabetes Care.* 2008;31(6):1237–41.
- Selvaraj J, Sathish S, Mayilvanan C, Balasubramanian K. Excess aldosterone-induced changes in insulin signaling molecules and glucose oxidation in gastrocnemius muscle of adult male rat. *Mol Cell Biochem.* 2013;372(1–2):113–26.
- Silverstein JM. Hyperglycemia induced by pasireotide in patients with Cushing’s disease or acromegaly. *Pituitary.* 2016;19(5):536–43.
- Taylor WH, Khaleeli AA. Coincident diabetes mellitus and primary hyperparathyroidism. *Diabetes Metab Res Rev.* 2001;17(3):175–80.
- Terzolo M, Pia A, Reimondo G. Subclinical Cushing’s syndrome: definition and management. *Clin Endocrinol.* 2012;76(1):12–8.
- Tosi F, Di Sarra D, Kaufman JM, Bonin C, Moretta R, Bonora E, et al. Total body fat and central fat mass independently predict insulin resistance but not hyperandrogenemia in women with polycystic ovary syndrome. *J Clin Endocrinol Metab.* 2015;100(2):661–9.
- van Beek AP, de Haas ER, van Vloten WA, Lips CJ, Roijers JF, Canninga-van Dijk MR. The glucagonoma syndrome and necrolytic migratory erythema: a clinical review. *Eur J Endocrinol.* 2004;151(5):531–7.
- Werbel SS, Ober KP. Pheochromocytoma. Update on diagnosis, localization, and management. *Med Clin N Am.* 1995;79(1):131–53.
- Wu S, Divall S, Nwaopara A, Radovick S, Wondisford F, Ko C, et al. Obesity-induced infertility and hyperandrogenism are corrected by deletion of the insulin receptor in the ovarian theca cell. *Diabetes.* 2014;63(4):1270–82.





# Hyperglycemic Crises: Diabetic Ketoacidosis and Hyperglycemic Hyperosmolar State

# 20

Guillermo E. Umpierrez

## Contents

Introduction .....	596
Pathogenesis .....	597
Precipitating Causes .....	599
Diagnosis .....	602
Symptoms and Signs .....	602
Laboratory Findings .....	604
Laboratory Pitfalls .....	605
Management of Hyperglycemic Crises .....	606
Fluid Therapy .....	606
Insulin Therapy .....	608
Potassium .....	608
Bicarbonate .....	609
Phosphate .....	609
Transition to Subcutaneous Insulin .....	609
Prevention .....	610
References .....	610

## Abstract

Diabetic ketoacidosis (DKA) and hyperglycemic hyperosmolar state (HHS) are the two most serious hyperglycemic emergencies in patients with diabetes mellitus. DKA most often occurs in patients with type 1 diabetes, but patients with type 2 diabetes are susceptible to DKA under stressful conditions such as trauma, surgery, or infections. HHS is more common in adult and elderly patients with poorly controlled type 2 diabetes. In the United States, the number of admissions for DKA has increased during the past decade to ~165,000 cases of each year.

G. E. Umpierrez (✉)

Department of Medicine, Division of Endocrinology and Metabolism, Emory University School of Medicine, Atlanta, GA, USA

e-mail: [Geumpie@emory.edu](mailto:Geumpie@emory.edu)

The rate of hospitalization for HHS is significantly lower, accounting for <1% of all diabetes-related admissions. DKA and HHS are characterized by insulinopenia and severe hyperglycemia; clinically, these two conditions differ by severity of metabolic acidosis, dehydration, and ketonemia. The overall mortality recorded among adults is <1–2% in patients with DKA and ~10–15% in patients with HHS. Management objectives for DKA and HHS include restoration of circulatory volume and tissue perfusion; correction of hyperglycemia, ketogenesis, and electrolyte imbalance; and identification and treatment of the precipitating event. This review describes the clinical presentation, precipitating causes, diagnosis, and acute management of these diabetic emergencies and of practical strategies for their prevention.

---

**Keywords**

Hyperglycemic emergencies · Ketoacidosis · Diabetic emergencies

---

## Introduction

Diabetic ketoacidosis (DKA) and hyperosmolar hyperglycemic state (HHS) are common endocrine emergencies associated with significant morbidity, mortality, and healthcare cost (Umpierrez and Korytkowski 2016; Kitabchi et al. 2009). DKA is reported to be responsible for more than 140,000 hospital admissions per year in the United States and accounts for 4–9% of all hospital discharge summaries among patients with primary diagnosis of diabetes (Centers for Disease Control and Prevention 1988). The prevalence of HHS is significantly lower than DKA accounting for about 1% of all related admissions of patients, and it is more common in elderly patients with poorly controlled type 2 diabetes (T2D) (Centers for Disease Control and Prevention 1988; Pasquel and Umpierrez 2014). Although there are important differences in their pathogenesis, the basic underlying mechanism for both disorders is the reduction in the net effective concentration of circulating insulin coupled with a concomitant elevation of counterregulatory hormones (glucagon, catecholamines, cortisol, and growth hormone) (Kitabchi et al. 2001). Clinically, they differ by the presence of increased ketone bodies and severity of metabolic acidosis (Ennis et al. 1994).

DKA most often occurs in patients with type 1 diabetes (T1D), but patients with type 2 diabetes are also susceptible to DKA under stressful conditions such as trauma, infections, and the use of certain medications. In the United States, the overall inpatient DKA mortality is <1% (Kitabchi et al. 2009; Centers for Disease Control and Prevention 2013), but a higher rate is reported among elderly patients with life-threatening illnesses (Kitabchi et al. 2009; Centers for Disease Control and Prevention 2013; Basu et al. 1993; Malone et al. 1992). Mortality in patients with HHS is reported in 5–16% which is about ten times higher than the mortality in patients with DKA (Umpierrez and Korytkowski 2016; Pasquel and Umpierrez 2014; Bhowmick et al. 2005; Fadini et al. 2011). The prognosis and outcome of patients with DKA or HHS are determined by the severity of dehydration, the

presence of comorbidities, and age >60 years (Umpierrez and Korytkowski 2016; Kitabchi et al. 2009). Treatment of hyperglycemic crises represents a substantial economic burden, with an estimated of \$17,500 per patient and a total annual hospital cost of \$2.4 billion (Kitabchi et al. 2009). General guidelines for treatment of DKA and HHS include aggressive rehydration, insulin therapy, electrolyte management, and search of any underlying precipitating events (Kitabchi et al. 2009).

This chapter reviews the precipitating causes, pathogenesis, and diagnosis and provides practical recommendations for the management of patients with hyperglycemic emergencies.

---

## Pathogenesis

In normal subjects during fasting state, plasma glucose is maintained between 3.9 and 5.6 mmol/L (70–100 mg/dL) by a finely regulated balance between hepatic glucose production and glucose utilization in peripheral tissues. Insulin controls are the primary regulators of hepatic glucose production by suppressing hepatic gluconeogenesis and glycogenolysis (McDonnell et al. 2005). In insulin-sensitive tissues such as muscle, insulin promotes protein anabolism, glucose uptake, and glycogen synthesis and inhibits glycogenolysis and protein breakdown. In addition, insulin is a powerful inhibitor of lipolysis, free fatty acid (FFA) oxidation, and ketogenesis (McDonnell et al. 2005; McGarry 1979).

DKA results from the lack of, or ineffectiveness of insulin with concomitant elevation of counterregulatory hormones (Umpierrez and Korytkowski 2016; McDonnell et al. 2005). The counterregulatory hormones (glucagon, catecholamines, cortisol, and growth hormone) promote metabolic pathways opposite to insulin action, both in the liver and peripheral tissues (Kitabchi et al. 2001; DeFronzo et al. 1994; Gerich et al. 1976).

The pathophysiologic basis for hyperglycemia and ketoacidosis in DKA is shown in Fig. 1. Hyperglycemia results from increased hepatic glucose production and impaired glucose utilization in peripheral tissues. Increased gluconeogenesis results from the high availability of gluconeogenic precursors (alanine, lactate, and glycerol) and from the increased activity of gluconeogenic enzymes (phosphoenolpyruvate carboxykinase (PEPCK), fructose-1,6-bisphosphatase, and pyruvate carboxylase). In addition, both hyperglycemia and high ketone levels cause an osmotic diuresis leading to hypovolemia and decreased glomerular filtration rate; the latter further aggravates hyperglycemia.

The association of insulin deficiency and increased concentration of catecholamine, cortisol, and growth hormone causes the activation of hormone-sensitive lipase in adipose tissue (Foster and McGarry 1983). This enzyme causes endogenous triglyceride breakdown with subsequent release of free fatty acids (FFA) into the circulation. Elevated FFA are transported into the hepatic mitochondria where they are oxidized to ketone bodies, a process predominantly stimulated by glucagon (DeFronzo et al. 1994; McGarry and Foster 1980). Glucagon lowers the hepatic

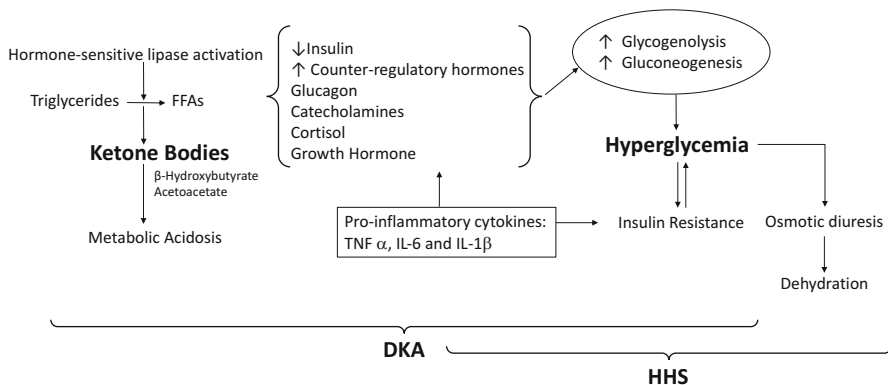

**Fig. 1** Pathogenesis of hyperglycemic emergencies. Hyperglycemia and accumulation of ketone bodies result from a relative or absolute insulin deficiency and excess counterregulatory hormones (glucagon, cortisol, catecholamines, and growth hormone). **Increased ketone bodies and ketoacidosis.** Decrease in insulin levels combined with increase in counterregulatory hormones, particularly epinephrine, causes the activation of hormone-sensitive lipase in adipose tissue and breakdown of triglyceride into glycerol and free fatty acids (FFAs). In the liver, FFAs are oxidized to ketone bodies, a process predominantly stimulated by glucagon. The two major ketone bodies are  $\beta$ -hydroxybutyrate and acetoacetic acid. Accumulation of ketone bodies leads to a decrease in serum bicarbonate concentration and metabolic acidosis. Higher insulin levels present in HHS inhibit ketogenesis and limit metabolic acidosis. **Increased glucose production in DKA and HHS.** When insulin is deficient, hyperglycemia develops because of three processes: increased gluconeogenesis, accelerated glycogenolysis, and impaired glucose utilization by peripheral tissues. Hyperglycemia causes osmotic diuresis that leads to hypovolemia, decreased glomerular filtration rate, and worsening hyperglycemia

levels of malonyl coenzyme A (CoA), the first committed intermediate in the synthesis of long-chain fatty acids (lipogenesis) and a potent inhibitor of fatty acid oxidation. Malonyl CoA inhibits carnitine palmitoyl acyltransferase, an enzyme that regulates movement of FFA into the mitochondria leading to increased keto acid production (McGarry et al. 1989). In addition to increased ketone body production, there is also evidence that decreased clearance of keto acids also contributes to the development of DKA. Ketone bodies are strong acids that, when present at high levels, can cause metabolic acidosis.

Patients with HHS also have significant insulin deficiency and increased concentration of counterregulatory hormones at presentation (Umpierrez and Korytkowski 2016; Ennis et al. 1994). The absence or minimal presence of ketosis, the key difference from DKA, has been speculatively explained by a higher plasma level of endogenous insulin secretion as well as lower levels of counterregulatory hormones in patients with HHS (Kitabchi et al. 2001). Serum concentration of C-peptide (an indicator of endogenous insulin secretion) in HHS is severalfold higher than those found in patients with DKA (Ennis et al. 1994). The higher insulin concentration is sufficient to suppress lipolysis and ketogenesis but is inadequate to regulate hepatic glucose production and promote glucose utilization (Ennis et al. 1994; Gerich et al. 1971).

Disturbances in hydration and electrolyte balance are of great importance in the pathogenesis of HHS. The osmotic diuresis due to hyperglycemia is characterized by urinary concentration of solutes, with combined urinary sodium and potassium concentrations of ~70–80 mEq/L (Kitabchi et al. 2001; Kitabchi and Wall 1995). Since HHS evolves during several days, continued osmotic diuresis leads to hypernatremia, significant volume loss, and impaired renal function, in particular in elderly patients with impaired thirst and/or inability to drink water to keep up with urinary losses.

Increasing evidence indicates that the development of severe hyperglycemia and ketoacidosis results in an inflammatory state characterized by an elevation of pro-inflammatory cytokines and increased oxidative stress markers (Rains and Jain 2011; Li et al. 2014; Shen and Braude 2012; Chaudhuri and Umpierrez 2012). Severe hyperglycemia induced macrophage production of pro-inflammatory cytokines, such as tumor necrosis factor- $\alpha$  (TNF- $\alpha$ ), interleukin (IL)-6, and IL-1 $\beta$ , and C-reactive protein that could impair insulin secretion and reduce insulin action (Li et al. 2014; Shen and Braude 2012; Vaarala and Yki-Jarvinen 2012; Pickup 2004). Elevation in FFAs also increases insulin resistance as well as impaired nitric oxide production in endothelial cells and endothelial dysfunction (Kim et al. 2005; Stentz et al. 2004). The increased inflammatory response, oxidative stress, and generation of reactive oxygen species (ROS) can lead to capillary perturbation and cellular damage of lipids, membranes, proteins, and DNA (Li et al. 2014; Chaudhuri and Umpierrez 2012). Increased inflammatory and oxidative stress markers return to normal levels following insulin administration and correction of hyperglycemia and acid-base status (Stentz et al. 2004; Shen et al. 2012).

---

## Precipitating Causes

Table 1 lists precipitating causes of DKA reported in international epidemiological studies (Umpierrez and Korytkowski 2016). DKA is the initial manifestation of diabetes in 20–30% of patients with type 1 diabetes. Worldwide, infection is the most common precipitating cause for DKA, occurring in 30–50% of cases. Urinary tract infection and pneumonia account for most infections (Umpierrez and Korytkowski 2016; Kitabchi et al. 2009). Tuberculosis and malaria are important precipitating causes in developing countries (Davis and Umpierrez 2007). In urban inner city populations, poor adherence to insulin therapy is the most common precipitation cause of DKA accounting for more than half of patients with their first and recurrent episodes of ketoacidosis (Umpierrez et al. 1997a; Randall et al. 2011). Other precipitating causes are intercurrent illnesses (i.e., surgery, trauma, myocardial ischemia, pancreatitis).

The importance of noncompliance and psychological factors in the incidence of DKA has been emphasized in recent studies. In a survey of 341 female patients with type 1 diabetes, Polonsky et al. (1994) reported that psychological problems complicated by eating disorders were contributing factors in 20% of recurrent

**Table 1** Precipitating causes of diabetic ketoacidosis by country

Precipitating causes, %	Australia	Brazil	China	Indonesia	Korea	Nigeria	Spain	Syria	Taiwan	USA
Newly diagnosed diabetes mellitus	5.7	12.2	NR	3.3	NR	NR	12.8	NR	18.2	17.2–23.8
Infection	28.6	25.0	39.2	58.3	25.3	32.5	33.2	47.8	31.7	14.0–16.0
Poor adherence to treatment	40.0	39.0	24.0	13.3	32.7	27.5	30.7	23.5	27.7	41.0–59.6
Other	25.7	15.0	10.9	17.1	11.2	4.8	23.3	7.8	6.2	9.7–18.0
Unknown	NA	8.8	25.9	8.0	30.8	34.6	NA	20.9	16.2	3.0–4.2

Adapted from Umpierrez and Korytkowski (2016)

NA Not applicable, NR Not reported

ketoacidosis in young women. Rydall et al. (1997) also reported that up to one-third of young women with type 1 diabetes have eating disturbances, which affect the management of diabetes and increase the risk of microvascular complications. Our group and others have reported that poor adherence to insulin is the major precipitating cause for DKA in urban black and medically indigent patients (Umpierrez et al. 1997a; Maldonado et al. 2003a; Musey et al. 1995). In a recent prospective study (Randall et al. 2011), stopping insulin therapy accounted for more than half of first and recurrent cases of DKA. More than 50% of subjects stopped or reduced the dose of insulin because of lack of money or access to medical care, because of behavioral or psychological reasons, or because they did not know how to manage diabetes on sick days. Substance abuse may also represent an important factor for poor compliance with insulin therapy in inner city patients with diabetes (Umpierrez et al. 1997a; Randall et al. 2011).

Several drugs that altered carbohydrate metabolism may precipitate the development of DKA including glucocorticoids, certain chemotherapeutic agents (Gerich et al. 1971; Ben Salem et al. 2011), and atypical antipsychotics (Caro et al. 2002; Buse et al. 2003; Gianfrancesco et al. 2003; Ananth et al. 2004). Of the antipsychotics, olanzapine and risperidone are associated with the highest risk (Lipscombe et al. 2014). Recently, the sodium glucose cotransporter 2 (SGLT2) inhibitors, a new class of oral antidiabetic agents that lower plasma glucose by inhibiting proximal tubular reabsorption of glucose in the kidney, have been associated with DKA in patients with T1D and T2D (Umpierrez and Korytkowski 2016; Peters et al. 2015; Taylor et al. 2015a; Gerich et al. 1971; Kitabchi and Wall 1995; Shen et al. 2012). Some of these patients present with mild elevations of blood glucose, a condition which has been referred to as “euglycemic DKA” (Peters et al. 2015). About 10% of patients with type 1 diabetes treated with SGLT2 inhibitors develop ketosis, and 5% require hospital admission for DKA (Peters et al. 2015). Randomized studies in patients with type 2 diabetes treated with SGLT2 inhibitors have reported a very low incidence ~0.07% of ketoacidosis in patients with T2D (Erondu et al. 2015; Tang et al. 2016). Proposed mechanisms of SGLT2-associated ketoacidosis include higher glucagon levels, reduction of daily insulin requirements leading to a decrease in the suppression of lipolysis and increased ketogenesis, and decreased urinary excretion of ketones (Kibbey 2015; Taylor et al. 2015b).

The use of continuous subcutaneous insulin infusion by an insulin pump was associated with an increased risk of DKA in early studies (Garg et al. 2004; Implementation of treatment, 1995); however, this is not a common event with newer improved pump technology and the use of frequent home glucose monitoring (Ly et al. 2013; Johnson et al. 2013).

Precipitating causes of HHS are similar to those causing DKA. HHS is the initial manifestation of diabetes in 7–17% of patients (Centers for Disease Control and Prevention, 1988; Pasquel and Umpierrez 2014). Infection is the major precipitating factor occurring in 30–60% of patients, with urinary tract infections and pneumonia being the most common infections (Davis and Umpierrez 2007). In many instances, an acute illness, such as cerebrovascular accident or myocardial infarction, that

provokes the release of counterregulatory hormones and/or compromises the access to water, may be the precipitating factor.

**Ketosis-prone Type 2 Diabetes.** During the past decade, an increasing number of ketoacidosis cases without precipitating cause have been reported in children, adolescents, and adult subjects with type 2 diabetes (American Diabetes Association, 2000; Umpierrez et al. 1995, 1999, 2006). More than half of obese African Americans with newly diagnosed diabetes presenting with DKA have type 2 diabetes (Umpierrez et al. 1997a; Vellanki et al. 2016). At presentation, they have markedly impaired insulin secretion and insulin action (Umpierrez et al. 1995; Mauvais-Jarvis et al. 2004). Unlike the insulin dependence seen in type 1 diabetes, after a few weeks, which is quite variable ranging from 2 to 12 weeks, insulin requirements decrease, and approximately 70% of patients who present with obese DKA achieve near-normoglycemia remission (Vellanki et al. 2016; McFarlane et al. 2001; Banerji et al. 1994). This clinical presentation has been reported primarily in Africans and African Americans (Umpierrez et al. 1995, 1999; Banerji et al. 1994; Sobngwi et al. 2002a; Kitabchi 2003) but also in other minority ethnic groups (Maldonado et al. 2003b; Balasubramanyam et al. 1999; Yamada and Nonaka 1996) and has been referred in the literature as idiopathic type 1 diabetes, atypical diabetes mellitus, type 1.5 diabetes, and more recently as ketosis-prone type 2 diabetes (Kitabchi 2003; Sobngwi et al. 2002b; Sobngwi and Gautier 2002; Maldonado et al. 2003c). The period of near-normoglycemia remission is variable. One study in 111 sub-Saharan black patients reported that 10 years after diabetes onset, 40% of patients with ketosis-prone type 2 diabetes are still non-insulin dependent (Mauvais-Jarvis et al. 2004). We and others have shown that treatment with sulfonylureas can prolong the period of near-normoglycemia remission (Banerji et al. 1995; Umpierrez et al. 1997b). A prospective randomized trial recently reported that treatment with metformin or sitagliptin was equally efficacious in prolongation of near-normoglycemia remission after stopping insulin therapy (Vellanki et al. 2016) (Table 2).

---

## Diagnosis

### Symptoms and Signs

The clinical presentation of DKA usually develops rapidly, over a time span of less than 24–48 h. Polyuria, polydipsia, and weight loss may be present for several days prior to the development of ketoacidosis, while vomiting, abdominal pain, and generalized weakness are frequently the presenting symptoms (Umpierrez and Freire 2002). Nausea and vomiting are reported in ~60% of patients and abdominal pain in 46% of patients. In a prospective study of 189 consecutive patients with DKA and 11 cases of HHS, the presence of abdominal pain did not relate to the severity of hyperglycemia but to the severity of metabolic acidosis. In DKA patients with abdominal pain, the mean serum bicarbonate ( $9 \pm 1$  mEq/L) and blood pH ( $7.12 \pm 0.02$ )



**Table 2** Clinical course of patients with ketosis-prone type 2 diabetes mellitus at presentation, near-normoglycemia remission, and long-term follow-up

	At presentation	Near-normoglycemia remission	Long-term follow-up
Symptoms	Polyuria, polydipsia, weight loss	None	None
Plasma glucose, mg/dL	>400	<126	Variable, risk of recurrence
HbA1c, %	>10	<7%	Variable
pH	<7.30	Normal	Normal
Bicarbonate, mmol	<18	Normal	Normal
$\beta$ -hydroxybutyrate, mmol/L	Positive, >3	Normal	Normal
$\beta$ -cell autoantibodies	Negative	Negative	Negative
Fasting and stimulated insulin secretion	Markedly reduced	Improved, like patients with T2D	Variable, progressive decline as in T2D
Insulin sensitivity	Markedly reduced	Improved, like patients with T2D	Variable, progressive decline as in T2D
Need for insulin treatment	Yes	None	May be needed with long-term follow-up
Response to oral antidiabetic agents	No	Yes	Yes

Adapted from Vellanki and Umpierrez (Vellanki et al. 2016)

were significantly lower than in patients without pain ( $15 \pm 1$  mEq/L and  $7.24 \pm 0.09$ , respectively). In that study, abdominal pain was present in 86% of patients with serum bicarbonate less than 5 mmol/L, in 66% of patients with levels of 5 to less than 10 mmol/L, in 36% of patients with levels 10 to less than 15 mmol/L, and in 13% of patients with bicarbonate levels 15–18 mmol/L. Only one patient with HHS reported nausea and vomiting on admission, but abdominal pain was not reported in any patient with HHS. The authors concluded that investigation of the etiology of abdominal pain in DKA should be reserved for patients without severe metabolic acidosis or if the pain persists after the resolution of ketoacidosis. The exact cause of abdominal pain in DKA has not been elucidated but has been attributed to delayed gastric emptying and ileus induced by electrolyte disturbance and metabolic acidosis.

Physical examination reveals signs of dehydration, including dry mucous membranes, tachycardia, and hypotension. Mental status can vary from full alertness to profound lethargy; however, fewer than 20% of patients are hospitalized with loss of consciousness (Umpierrez et al. 1995). Patients in DKA may exhibit Kussmaul respirations and a classic fruity (acetone) breath odor. Although the most common precipitating event is infection, most patients are normothermic or even hypothermic, at presentation. If a patient with DKA becomes febrile, a vigorous search for an underlying infection must be undertaken.

## Laboratory Findings

The syndrome of DKA consists of the triad of hyperglycemia, hyperketonemia, and metabolic acidosis. Diagnostic criteria for DKA accepted by most experts in the field are a blood glucose greater than 250 mg/dL, pH lower than 7.3, serum bicarbonate lower than 15 mEq/L, increased anion gap metabolic acidosis  $>12$ , and a moderate degree of ketonemia (beta-hydroxybutyrate greater than 3 mmol) (Umpierrez and Korytkowski 2016; Kitabchi et al. 2009). Anion gap is calculated with the following formula: sodium  $[Na^+] - (chloride [Cl^-] + [HCO_3^-])$ . The American Diabetes Association classifies DKA by severity as mild, moderate, or severe depending on the degree of acidosis and altered sensorium (Table 3; Kitabchi et al. 2009). Although the majority of patients present with plasma glucose levels  $>250$  mg/dL, some patients exhibit only mild elevations in plasma glucose levels (termed “euglycemic DKA”) (Jenkins et al. 1993). This condition has been reported during pregnancy, prolonged starvation, alcohol intake, and more recently, in patients treated with SGLT2 inhibitors (Peters et al. 2015; Bas et al. 2015; Guo et al. 2008).

The key diagnostic feature is the elevation in circulating total blood ketone concentration. The assessment of augmented ketonemia is preferably performed by measurement of beta-hydroxybutyrate, the main ketone body in DKA. The nitroprusside test, which provides a semiquantitative estimation of acetoacetate and acetone levels, is highly sensitive, but it can underestimate the severity of ketoacidosis because the assay does not recognize the presence of beta hydroxybutyrate (Foster and McGarry 1983; Stephens et al. 1971).

The diagnostic criteria for HHS include a plasma glucose concentration greater than 600 mg/dL, a serum osmolality greater than 320 mOsm/kg, and the absence of

**Table 3** Diagnostic criteria for DKA and HHS

Measure	DKA			HHS
	Mild	Moderate	Severe	
Plasma glucose (mg/dL)	$>250$	$>250$	$>250$	$>600$
Arterial pH	7.25–7.30	7.00 to $<7.24$	$<7.00$	$>7.30$
Serum bicarbonate (mEq/L)	15–18	10 to $<15$	$<10$	$>18$
Urine or serum ketones <sup>a</sup>	Positive	Positive	Positive	Small
Urine or serum $\beta$ -hydroxybutyrate (mmol/L)	$>3.0$	$>3.0$	$>3.0$	$<3.0$
Effective serum osmolality <sup>b</sup>	Variable	Variable	Variable	$>320$ mOsm/kg
Anion gap	$>10$	$>12$	$>12$	Variable
Mental status	Alert	Alert/drowsy	Stupor/coma	Stupor/coma

Adapted from Kitabchi et al. (2009) American Diabetes Association Consensus Statement on Hyperglycemic Crises, 2009

<sup>a</sup>Nitroprusside reaction

<sup>b</sup>Effective serum osmolality:  $2[\text{measured } Na^+ \text{ (mEq/L)}] + \text{glucose (mg/dL)}/18$

ketoacidosis (Umpierrez and Korytkowski 2016; Kitabchi et al. 2009). Most patients with HHS have a serum pH greater than 7.3, a serum bicarbonate greater than 18 mEq/L, and negative ketone bodies in urine and plasma; mild ketonemia may be present (Kitabchi et al. 2001). Estimates suggest that ~20–30% of patients who present with HHS exhibit increased anion gap metabolic acidosis as the result of concomitant ketoacidosis, either alone or in combination with increased serum levels of lactate (Umpierrez and Korytkowski 2016; Kitabchi et al. 2001; Umpierrez et al. 1997a).

The importance of increased serum osmolality in the clinical presentation and outcome of patients with hyperglycemic crises is well established (Ennis et al. 1994). Altered sensorium (lethargy, stupor, and coma) correlates better with hyperosmolality than with patients' age or severity of acid-base disturbance. Hyperosmolality in patients with HHS was first calculated by the formula: total serum osmolality  $[2(\text{Na}) + 18/\text{glucose} + \text{BUN}/2]$  (Ennis et al. 1994; Arieff and Carroll 1971), but recent reports have recommended the use of effective serum osmolality  $[2(\text{Na}) + 18/\text{glucose}]$  not taking into consideration urea, as the osmotic contribution of urea is not significant compared with the effects of sodium and glucose levels (Ennis et al. 1994). Urea is distributed equally in all body compartments, and its accumulation does not induce an osmotic gradient across the cell membranes. Symptoms of encephalopathy are usually present when serum sodium levels exceed 160 mEq/L and when the calculated total and effective osmolality is greater than 340 and 320 mOsm/kg, respectively (Pasquel and Umpierrez 2014).

---

## Laboratory Pitfalls

Clinicians should keep in mind that not all patients who present with ketoacidosis have DKA. Patients with chronic ethanol abuse with a recent binge culminating in nausea, vomiting, and acute starvation may present with alcoholic ketoacidosis (Umpierrez et al. 2000; Wrenn et al. 1991). The key diagnostic feature that differentiates diabetic- and alcohol-induced ketoacidosis is the concentration of blood glucose (Fulop 1989). While DKA is characterized by severe hyperglycemia, the presence of ketoacidosis without hyperglycemia in an alcoholic patient is virtually diagnostic of alcoholic ketoacidosis (Umpierrez et al. 2000; Fulop 1989). In addition, some patients with decreased food intake (lower than 500 calories/day) for several days may present with starvation ketosis (Cahill 2006). However, a healthy subject can adapt to prolonged fasting by increasing ketone clearance by peripheral tissue (brain and muscle) and by enhancing the kidney's ability to excrete ammonia to compensate for the increased acid production. Therefore, a patient with starvation ketosis rarely presents with a serum bicarbonate concentration less than 18 mEq/L (Cahill 2006).

The admission serum sodium is usually low in DKA and HHS because of the osmotic flux of water from the intracellular to the extracellular space in the presence of hyperglycemia. An increase in serum sodium concentration in the presence of

hyperglycemia indicates a rather profound degree of water loss. To assess the severity of sodium and water deficit, serum sodium may be corrected by adding 1.6 mg/dL to the measured serum sodium for each 100 mg/dL of glucose above 100 mg/dL.

The admission serum potassium concentration is usually elevated in patients with DKA and HHS. In several studies (Kitabchi et al. 2009; Randall et al. 2011; Beigelman 1973), the mean serum potassium in patients with DKA and HHS was 5.6 mEq/L and 5.7 mEq/L, respectively. These high levels occur because of a shift of potassium from the intracellular to the extracellular space due to insulin deficiency and hypertonicity as well as acidemia in DKA (Adrogué et al. 1986).

Most patients with DKA present with leukocytosis with white cell counts in the 10,000–15,000 mm<sup>3</sup> range; however, a leukocyte count greater than 25,000 mm<sup>3</sup> or the presence of greater than 10% neutrophil bands is seldom seen in the absence of bacterial infection.

---

## Management of Hyperglycemic Crises

Successful treatment of DKA requires restoration of circulatory volume and tissue perfusion, resolution of hyperglycemia, correction of electrolyte imbalance and acid-base disorder, cessation of ketogenesis, and careful search for the precipitating cause of metabolic decompensation (Fig. 2).

---

### Fluid Therapy

Patients with DKA are invariably volume depleted fluid deficit ~4–6 L, priority should be given to fluid resuscitation and electrolyte replacement. Initial fluid therapy is directed towards the expansion of intravascular volume and restoration of renal perfusion. Isotonic saline (0.9% NaCl) is infused at a rate of 15–20 mL/kg (500–1000 mL/h) during the first 2 h, followed by 250–500 mL/h. After intravascular volume depletion is corrected, the rate of normal saline infusion should be reduced to 250 mL/h or changed to 0.45% saline depending upon the serum sodium concentration. The free water deficit can be estimated, based on corrected serum sodium concentration, using the following equation: water deficit = (0.6) (body weight in kilograms) × (1 – [corrected sodium/140]) (Kitabchi et al. 2009). The goal is to replace half the estimated water deficit over a period of 12–24 h.

Once the plasma glucose reaches 250 mg/dL, replacement fluids should contain 5–10% dextrose to allow continued insulin administration until ketonemia is controlled while avoiding hypoglycemia (Kitabchi et al. 2009). An additional important aspect of fluid management in hyperglycemic states is to replace the volume of urinary losses. Failure to adjust fluid replacement for urinary losses may delay correction of electrolytes and water deficit.

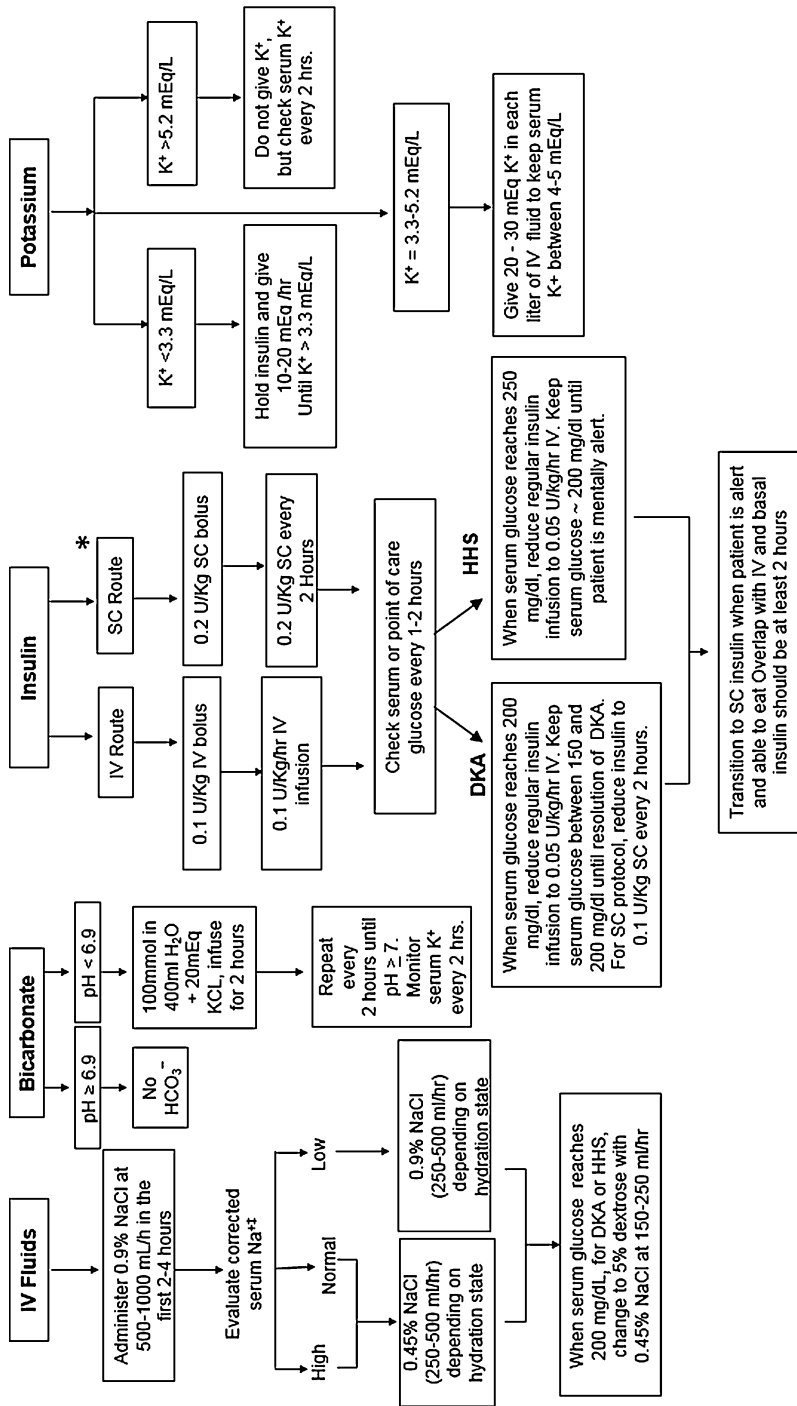

**Fig. 2** Management of DKA and HHS. (Adapted from Kitabchi et al. (2009) American Diabetes Association Consensus Statement on Hyperglycemic Crises, 2009)

## Insulin Therapy

Insulin administration increases peripheral glucose utilization and decreases hepatic glucose production, thereby lowering blood glucose concentration. In addition, insulin therapy inhibits lipolysis and release of free fatty acid from adipose tissue and ketogenesis.

Regular insulin given intravenously by continuous infusion remains the drug of choice. Intermittent infusion or hourly boluses of low-dose intravenous insulin should be avoided because of regular insulin's short half-life. Most clinical guidelines recommend an initial intravenous bolus of regular insulin of 0.1 units/kg of body weight, followed by a continuous infusion of regular insulin at a dose of 0.1 units/kg per hour until blood glucose levels reach 250 mg/dL (Kitabchi et al. 2009). At this time, dextrose should be added to intravenous fluids, and the insulin infusion rate is reduced to 0.05 units/kg per hour. Thereafter, the rate of insulin administration may need to be adjusted to maintain glucose levels at approximately 200 mg/dL and continued until ketoacidosis is resolved.

Several studies have reported that the administration of subcutaneous doses of rapid insulin analogs (lispro and aspart) every 1–2 h represents an effective alternative to the intravenous infusion of regular insulin in the management of patients with mild to moderate DKA (Umpierrez et al. 2004a; Ersoz et al. 2006; Karoli et al. 2011). Patients are treated with an initial bolus of 0.2–0.3 U/kg followed by 0.1–0.2 U/kg every 1–2 h, respectively, until glucose is lower than 250 mg/dL. The dose is then reduced by half to 0.05 U/kg every 1 h or 0.01 U/kg every 2 h until resolution of DKA (Umpierrez et al. 2004a, b). The use of intramuscular injections of rapid-acting insulin is also effective in the treatment of DKA, but this route tends to be more painful than subcutaneous injection and might increase the risk of bleeding among patients receiving anticoagulation therapy (Umpierrez and Korytkowski 2016; Kitabchi et al. 1976). The use of rapid-acting subcutaneous insulin analogs is not recommended for patients with arterial hypotension, severe and complicated DKA, or with HHS.

---

## Potassium

Despite a total body potassium deficit, most patients with DKA and HHS have a serum potassium level at or above the upper limits of normal (Kitabchi et al. 2009; Randall et al. 2011; Beigelman 1973). With initiation of therapy, the extracellular potassium concentration invariably falls. Therefore, to prevent hypokalemia, replacement with intravenous potassium chloride (20–30 mEq/L) is recommended when the serum potassium concentration is below 5.5 mEq/L. The treatment goal is to maintain serum potassium levels within the normal range of 4–5 mEq/L. In some hyperglycemic patients with severe potassium deficiency, insulin administration may precipitate profound hypokalemia, which can induce life-threatening arrhythmias and respiratory muscle weakness (Abramson and Arky 1966). Thus, if the initial serum potassium is equal or lower than 3.0 mEq/L, potassium replacement should

begin immediately by an infusion of potassium chloride at a rate of 10–20 mEq per hour, and one may consider withholding insulin therapy until sufficient intravenous potassium replacement is given (1–2 h).

---

## Bicarbonate

Bicarbonate administration in patients with DKA remains controversial. Rapid alkalization may result in hypokalemia, paradoxical central nervous system acidosis, and worsened intracellular acidosis (because of increased carbon dioxide production) with overshoot alkalosis. Several studies have shown lack of benefits of bicarbonate administration in patients with arterial pH greater than 6.9–7.0 (Green et al. 1998; Latif et al. 2002). In patients with more severe metabolic acidosis (pH <6.9), 44.6 mEq of sodium bicarbonate should be added to a liter of hypotonic saline until pH rises to at least 7.0 (Kitabchi et al. 2009). In patients with arterial pH >7.0, no bicarbonate therapy is necessary.

---

## Phosphate

Total body phosphate deficiency is present in most patients with DKA. Several studies have failed to show any beneficial effect of phosphate replacement on clinical outcome (Fisher and Kitabchi 1983; Wilson et al. 1982). Furthermore, aggressive phosphate therapy is potentially hazardous, as indicated in case reports of children with DKA who developed hypocalcemia and tetany secondary to intravenous phosphate administration (Winter et al. 1979). Careful phosphate replacement may be indicated in patients with cardiac dysfunction, anemia, respiratory depression, and serum phosphate concentration lower than 1.0–1.5 mg/dL (Kitabchi et al. 2009).

---

## Transition to Subcutaneous Insulin

Criteria for resolution of ketoacidosis include a blood glucose lower than 250 mg/dL, a serum bicarbonate level equal to or greater than 18 mEq/L, a pH greater than 7.3, and a calculated anion gap equal to or lower than 14 mEq/L (Kitabchi et al. 2009). The resolution of HHS is indicated by an effective serum osmolality <310 mmol/kg and a plasma glucose level  $\leq$  13.8 mmol/L in a patient who has recovered mental alertness (Kitabchi et al. 2009).

Due to the short half-life of insulin (<10 min), patients with hyperglycemic crises should be treated with continuous intravenous insulin until ketoacidosis is resolved. When this occurs, subcutaneous insulin therapy can be started. In patients with newly diagnosed diabetes or who have not been treated with insulin prior to admission and initial insulin, total insulin dose of 0.5–0.6 units/kg/day is usually sufficient to achieve and maintain metabolic control. Patients with

confirmed diabetes mellitus who were treated with subcutaneous insulin before hospital admission can resume their previous insulin regimen. The use of basal bolus regimen with insulin analogs is preferred over the use of intermediate-acting insulin (NPH) and regular insulin due to the lower rate of hospital hypoglycemia (Umpierrez et al. 2009). In a recent study, treatment with insulin analogs (glargine once daily and glulisine before meals) resulted in similar glucose control compared to NPH insulin twice daily and regular before meals; however, the hypoglycemia was reported in 41% of patients with MPH/regular regimen versus 15% in the basal bolus regimen (Umpierrez et al. 2009).

---

## Prevention

Diabetes education and assurance of appropriate follow-up after hospital discharge may reduce the risk of readmissions in patients with DKA (Jefferies et al. 2015; Laffel 2000; Vanelli et al. 1999). Development of system-wide changes such as assistance programs to provide insulin to patients and reduce lapses in treatment may be a cost-effective way to reduce the rate of hospitalization for hyperglycemic emergencies. Sick-day rule education is of great importance in preventing hospital readmissions. Patients with T1D should be instructed on the use of home blood ketone monitoring during illness and persistent hyperglycemia, which may allow for early recognition of impending ketoacidosis. Many patients with recurrent DKA are unaware of sick-day management or the consequences of skipping or discontinuing insulin therapy (Laffel 2000). In addition, diabetes education and sick-day management should be reviewed periodically in patients with T1D. It has also been shown that frequent visits to diabetes centers can improve glycemic control and reduce the frequency of emergency admissions for DKA. Multidisciplinary approaches with the use of clinical diabetes educators in close contact with and easily accessible to the patients have been shown to reduce the number of hospitalizations related to hyperglycemic emergencies (Deeb et al. 2016).

---

## References

- Abramson E, Arky R. Diabetic acidosis with initial hypokalemia. Therapeutic implications. *JAMA*. 1966;196(5):401–3.
- Adrogue HJ, Lederer ED, Suki WN, Eknoyan G. Determinants of plasma potassium levels in diabetic ketoacidosis. *Medicine (Baltimore)*. 1986;65(3):163–72.
- American Diabetes Association. Type 2 diabetes in children and adolescents. *Pediatrics*. 2000;105(3 Pt 1):671–80.
- Ananth J, Parameswaran S, Gunatilake S. Side effects of atypical antipsychotic drugs. *Curr Pharm Des*. 2004;10(18):2219–29.
- Arieff AI, Carroll HJ. Hyperosmolar nonketotic coma with hyperglycemia: abnormalities of lipid and carbohydrate metabolism. *Metabolism*. 1971;20(6):529–38.
- Balasubramanyam A, Zern JW, Hyman DJ, Pavlik V. New profiles of diabetic ketoacidosis: type 1 vs type 2 diabetes and the effect of ethnicity. *Arch Intern Med*. 1999;159(19):2317–22.



- Banerji MA, Chaiken RL, Huey H, et al. GAD antibody negative NIDDM in adult black subjects with diabetic ketoacidosis and increased frequency of human leukocyte antigen DR3 and DR4. Flatbush diabetes. *Diabetes*. 1994;43(6):741–5.
- Banerji MA, Chaiken RL, Lebovitz HE. Prolongation of near-normoglycemic remission in black NIDDM subjects with chronic low-dose sulfonylurea treatment. *Diabetes*. 1995;44(4):466–70.
- Bas VN, Uytun S, Torun YA. Diabetic euglycemic ketoacidosis in newly diagnosed type 1 diabetes mellitus during Ramadan fasting. *J Pediatr Endocrinol Metab*. 2015;28(3–4):333–5.
- Basu A, Close CF, Jenkins D, Krentz AJ, Natrass M, Wright AD. Persisting mortality in diabetic ketoacidosis. *Diabet Med*. 1993;10(3):282–4.
- Beigelman PM. Potassium in severe diabetic ketoacidosis. *Am J Med*. 1973;54(4):419–20.
- Ben Salem C, Fathallah N, Hmouda H, Bouraoui K. Drug-induced hypoglycaemia: an update. *Drug Saf*. 2011;34(1):21–45.
- Bhowmick SK, Levens KL, Rettig KR. Hyperosmolar hyperglycemic crisis: an acute life-threatening event in children and adolescents with type 2 diabetes mellitus. *Endocr Pract*. 2005;11(1):23–9.
- Buse JB, Cavazzoni P, Hornbuckle K, Hutchins D, Breier A, Jovanovic L. A retrospective cohort study of diabetes mellitus and antipsychotic treatment in the United States. *J Clin Epidemiol*. 2003;56(2):164–70.
- Cahill GF Jr. Fuel metabolism in starvation. *Annu Rev Nutr*. 2006;26:1–22.
- Caro JJ, Ward A, Levinton C, Robinson K. The risk of diabetes during olanzapine use compared with risperidone use: a retrospective database analysis. *J Clin Psychiatry*. 2002;63(12):1135–9.
- Centers for Disease Control and Prevention, Department of Health and Human Services: Diabetes Data & Trends. Crude and Age-Adjusted Hospital Discharge Rates for Diabetic Ketoacidosis as First-Listed Diagnosis per 1,000 Diabetic Population, United States. 1988–2009. <http://www.cdc.gov/diabetes/statistics/dkafirst/>. Accessed Jan 2013.
- Centers for Disease Control and Prevention. Mortality due to Hyperglycemic crises. 2013. [http://www.cdc.gov/diabetes/statistics/complications\\_national.htm](http://www.cdc.gov/diabetes/statistics/complications_national.htm). Accessed 2 Sept 2016.
- Chaudhuri A, Umpierrez GE. Oxidative stress and inflammation in hyperglycemic crises and resolution with insulin: implications for the acute and chronic complications of hyperglycemia. *J Diabetes Complicat*. 2012;26(4):257–8.
- Davis SN, Umpierrez GE. Diabetic ketoacidosis in type 2 diabetes mellitus – pathophysiology and clinical presentation. *Nat Clin Pract Endocrinol Metab*. 2007;3(11):730–1.
- Deeb A, Yousef H, Abdelrahman L, et al. Implementation of a diabetes educator care model to reduce paediatric admission for diabetic ketoacidosis. *J Diabetes Res*. 2016;2016:3917806.
- DeFronzo RA, Matzuda M, Barret E. Diabetic ketoacidosis: a combined metabolic-nephrologic approach to therapy. *Diabetes Rev*. 1994;2:209–38.
- Ennis ED, Stahl EJVB, Kreisberg RA. The hyperosmolar hyperglycemic syndrome. *Diabetes Rev*. 1994;2:115–26.
- Erundu N, Desai M, Ways K, Meininger G. Diabetic ketoacidosis and related events in the Canagliflozin type 2 diabetes clinical program. *Diabetes Care*. 2015;38(9):1680–6.
- Ersoz HO, Ukinc K, Kose M, et al. Subcutaneous lispro and intravenous regular insulin treatments are equally effective and safe for the treatment of mild and moderate diabetic ketoacidosis in adult patients. *Int J Clin Pract*. 2006;60(4):429–33.
- Fadini GP, de Kreutzenberg SV, Rigato M, et al. Characteristics and outcomes of the hyperglycemic hyperosmolar non-ketotic syndrome in a cohort of 51 consecutive cases at a single center. *Diabetes Res Clin Pract*. 2011;94(2):172–9.
- Fisher JN, Kitabchi AE. A randomized study of phosphate therapy in the treatment of diabetic ketoacidosis. *J Clin Endocrinol Metab*. 1983;57(1):177–80.
- Foster DW, McGarry JD. The metabolic derangements and treatment of diabetic ketoacidosis. *N Engl J Med*. 1983;309(3):159–69.
- Fulop M. Alcoholism, ketoacidosis, and lactic acidosis. *Diabetes Metab Rev*. 1989;5(4):365–78.

- Garg SK, Walker AJ, Hoff HK, D'Souza AO, Gottlieb PA, Chase HP. Glycemic parameters with multiple daily injections using insulin glargine versus insulin pump. *Diabetes Technol Ther.* 2004;6(1):9–15.
- Gerich JE, Martin MM, Recant L. Clinical and metabolic characteristics of hyperosmolar non-ketotic coma. *Diabetes.* 1971;20(4):228–38.
- Gerich JE, Lorenzi M, Bier DM, et al. Effects of physiologic levels of glucagon and growth hormone on human carbohydrate and lipid metabolism. Studies involving administration of exogenous hormone during suppression of endogenous hormone secretion with somatostatin. *J Clin Invest.* 1976;57(4):875–84.
- Gianfrancesco F, Grogg A, Mahmoud R, Wang RH, Meletiche D. Differential effects of antipsychotic agents on the risk of development of type 2 diabetes mellitus in patients with mood disorders. *Clin Ther.* 2003;25(4):1150–71.
- Green SM, Rothrock SG, Ho JD, et al. Failure of adjunctive bicarbonate to improve outcome in severe pediatric diabetic ketoacidosis. *Ann Emerg Med.* 1998;31(1):41–8.
- Guo RX, Yang LZ, Li LX, Zhao XP. Diabetic ketoacidosis in pregnancy tends to occur at lower blood glucose levels: case-control study and a case report of euglycemic diabetic ketoacidosis in pregnancy. *J Obstet Gynaecol Res.* 2008;34(3):324–30.
- Diabetes Control and Complications Trial (DCCT). Implementation of treatment protocols in the Diabetes Control and Complications Trial. *Diabetes Care.* 1995;18(3):361–76.
- Jefferies CA, Nakhla M, Derraik JG, Gunn AJ, Daneman D, Cutfield WS. Preventing diabetic ketoacidosis. *Pediatr Clin N Am.* 2015;62(4):857–71.
- Jenkins D, Close CF, Krentz AJ, Nattrass M, Wright AD. Euglycaemic diabetic ketoacidosis: does it exist? *Acta Diabetol.* 1993;30(4):251–3.
- Johnson SR, Cooper MN, Jones TW, Davis EA. Long-term outcome of insulin pump therapy in children with type 1 diabetes assessed in a large population-based case-control study. *Diabetologia.* 2013;56(11):2392–400.
- Karoli R, Fatima J, Salman T, Sandhu S, Shankar R. Managing diabetic ketoacidosis in non-intensive care unit setting: role of insulin analogs. *Indian J Pharm.* 2011;43(4):398–401.
- Kibbey RG. SGLT-2 inhibition and glucagon: cause for alarm? *Trends Endocrinol Metab.* 2015;26(7):337–8.
- Kim F, Tysseling KA, Rice J, et al. Free fatty acid impairment of nitric oxide production in endothelial cells is mediated by IKKbeta. *Arterioscler Thromb Vasc Biol.* 2005;25(5):989–94.
- Kitabchi AE. Ketosis-prone diabetes – a new subgroup of patients with atypical type 1 and type 2 diabetes? *J Clin Endocrinol Metab.* 2003;88(11):5087–9.
- Kitabchi AE, Wall BM. Diabetic ketoacidosis. *Med Clin North Am.* 1995;79(1):9–37.
- Kitabchi AE, Ayyagari V, Guerra SM. The efficacy of low-dose versus conventional therapy of insulin for treatment of diabetic ketoacidosis. *Ann Intern Med.* 1976;84(6):633–8.
- Kitabchi AE, Umpierrez GE, Murphy MB, et al. Management of hyperglycemic crises in patients with diabetes. *Diabetes Care.* 2001;24(1):131–53.
- Kitabchi AE, Umpierrez GE, Miles JM, Fisher JN. Hyperglycemic crises in adult patients with diabetes. *Diabetes Care.* 2009;32(7):1335–43.
- Laffel L. Sick-day management in type 1 diabetes. *Endocrinol Metab Clin N Am.* 2000;29(4):707–23.
- Latif KA, Freire AX, Kitabchi AE, Umpierrez GE, Qureshi N. The use of alkali therapy in severe diabetic ketoacidosis. *Diabetes Care.* 2002;25(11):2113–4.
- Li J, Huang M, Shen X. The association of oxidative stress and pro-inflammatory cytokines in diabetic patients with hyperglycemic crisis. *J Diabetes Complicat.* 2014;28(5):662–6.
- Lipscombe LL, Austin PC, Alessi-Severini S, et al. Atypical antipsychotics and hyperglycemic emergencies: multicentre, retrospective cohort study of administrative data. *Schizophr Res.* 2014;154(1–3):54–60.
- Ly TT, Nicholas JA, Retterath A, Lim EM, Davis EA, Jones TW. Effect of sensor-augmented insulin pump therapy and automated insulin suspension vs standard insulin pump therapy on hypoglycemia in patients with type 1 diabetes: a randomized clinical trial. *JAMA.* 2013;310(12):1240–7.
- Maldonado MR, Chong ER, Oehl MA, Balasubramanyam A. Economic impact of diabetic ketoacidosis in a Multiethnic indigent population: analysis of costs based on the precipitating cause. *Diabetes Care.* 2003a;26(4):1265–9.

- Maldonado M, Hampe CS, Gaur LK, et al. Ketosis-prone diabetes: dissection of a heterogeneous syndrome using an immunogenetic and beta-cell functional classification, prospective analysis, and clinical outcomes. *J Clin Endocrinol Metab.* 2003b;88(11):5090–8.
- Maldonado MR, Otiniano ME, Lee R, Rodriguez L, Balasubramanyam A. Ethnic differences in beta-cell functional reserve and clinical features in patients with ketosis-prone diabetes. *Diabetes Care.* 2003c;26(8):2469.
- Malone ML, Gennis V, Goodwin JS. Characteristics of diabetic ketoacidosis in older versus younger adults. *J Am Geriatr Soc.* 1992;40(11):1100–4.
- Mauvais-Jarvis F, Sobngwi E, Porcher R, et al. Ketosis-prone type 2 diabetes in patients of sub-Saharan African origin: clinical pathophysiology and natural history of beta-cell dysfunction and insulin resistance. *Diabetes.* 2004;53(3):645–53.
- McDonnell CM, Pedreira CC, Vadamalayan B, Cameron FJ, Werther GA. Diabetic ketoacidosis, hyperosmolality and hypernatremia: are high-carbohydrate drinks worsening initial presentation? *Pediatr Diabetes.* 2005;6(2):90–4.
- McFarlane SI, Chaiken RL, Hirsch S, Harrington P, Lebovitz HE, Banerji MA. Near-normal glycaemic remission in African-Americans with type 2 diabetes mellitus is associated with recovery of beta cell function. *Diabet Med.* 2001;18(1):10–6.
- McGarry JD. Lilly Lecture 1978. New perspectives in the regulation of ketogenesis. *Diabetes.* 1979;28(5):517–23.
- McGarry JD, Foster DW. Regulation of hepatic fatty acid oxidation and ketone body production. *Annu Rev Biochem.* 1980;49:395–420.
- McGarry JD, Woeltje KF, Kuwajima M, Foster DW. Regulation of ketogenesis and the renaissance of carnitine palmitoyltransferase. *Diabetes Metab Rev.* 1989;5(3):271–84.
- Musey VC, Lee JK, Crawford R, Klatka MA, McAdams D, Phillips LS. Diabetes in urban African-Americans. I. Cessation of insulin therapy is the major precipitating cause of diabetic ketoacidosis. *Diabetes Care.* 1995;18(4):483–9.
- Pasquel FJ, Umptier GE. Hyperosmolar hyperglycemic state: a historic review of the clinical presentation, diagnosis, and treatment. *Diabetes Care.* 2014;37(11):3124–31.
- Peters AL, Buschur EO, Buse JB, Cohan P, Diner JC, Hirsch IB. Euglycemic diabetic ketoacidosis: a potential complication of treatment with sodium-glucose cotransporter 2 inhibition. *Diabetes Care.* 2015;38(9):1687–93.
- Pickup JC. Inflammation and activated innate immunity in the pathogenesis of type 2 diabetes. *Diabetes Care.* 2004;27(3):813–23.
- Polonsky WH, Anderson BJ, Lohrer PA, Aponte JE, Jacobson AM, Cole CF. Insulin omission in women with IDDM. *Diabetes Care.* 1994;17(10):1178–85.
- Rains JL, Jain SK. Oxidative stress, insulin signaling, and diabetes. *Free Radic Biol Med.* 2011;50(5):567–75.
- Randall L, Begovic J, Hudson M, et al. Recurrent diabetic ketoacidosis in inner-city minority patients: behavioral, socioeconomic, and psychosocial factors. *Diabetes Care.* 2011;34(9):1891–6.
- Rydall AC, Rodin GM, Olmsted MP, Devenyi RG, Daneman D. Disordered eating behavior and microvascular complications in young women with insulin-dependent diabetes mellitus. *N Engl J Med.* 1997;336(26):1849–54.
- Shen T, Braude S. Changes in serum phosphate during treatment of diabetic ketoacidosis: predictive significance of severity of acidosis on presentation. *Intern Med J.* 2012;42(12):1347–50.
- Shen XP, Li J, Zou S, Wu HJ, Zhang Y. The relationship between oxidative stress and the levels of serum circulating adhesion molecules in patients with hyperglycemia crises. *J Diabetes Complicat.* 2012;26(4):291–5.
- Sobngwi E, Gautier JF. Adult-onset idiopathic type I or ketosis-prone type II diabetes: evidence to revisit diabetes classification. *Diabetologia.* 2002;45(2):283–5.
- Sobngwi E, Vexiau P, Levy V, et al. Metabolic and immunogenetic prediction of long-term insulin remission in African patients with atypical diabetes. *Diabet Med.* 2002a;19(10):832–5.
- Sobngwi E, Mauvais-Jarvis F, Vexiau P, Mbanya JC, Gautier JF. Diabetes in Africans. Part 2: ketosis-prone atypical diabetes mellitus. *Diabetes Metab.* 2002b;28(1):5–12.

- Stentz FB, Umpierrez GE, Cuervo R, Kitabchi AE. Proinflammatory cytokines, markers of cardiovascular risks, oxidative stress, and lipid peroxidation in patients with hyperglycemic crises. *Diabetes*. 2004;53(8):2079–86.
- Stephens JM, Sulway MJ, Watkins PJ. Relationship of blood acetoacetate and 3-hydroxybutyrate in diabetes. *Diabetes*. 1971;20(7):485–9.
- Tang H, Li D, Wang T, Zhai S, Song Y. Effect of sodium-glucose cotransporter 2 inhibitors on diabetic ketoacidosis among patients with type 2 diabetes: a meta-analysis of randomized controlled trials. *Diabetes Care*. 2016;39(8):e123–4.
- Taylor SI, Blau JE, Rother KI. Perspective: SGLT2 inhibitors may predispose to ketoacidosis. *J Clin Endocrinol Metabol*. 2015a. <https://doi.org/10.1210/jc.2015-1884>.
- Taylor SI, Blau JE, Rother KI. SGLT2 inhibitors may predispose to ketoacidosis. *J Clin Endocrinol Metab*. 2015b;100(8):2849–52.
- Umpierrez G, Freire AX. Abdominal pain in patients with hyperglycemic crises. *J Crit Care*. 2002;17(1):63–7.
- Umpierrez G, Korytkowski M. Diabetic emergencies – ketoacidosis, hyperglycaemic hyperosmolar state and hypoglycaemia. *Nat Rev Endocrinol*. 2016;12(4):222–32.
- Umpierrez GE, Casals MM, Gebhart SP, Mixon PS, Clark WS, Phillips LS. Diabetic ketoacidosis in obese African-Americans. *Diabetes*. 1995;44(7):790–5.
- Umpierrez GE, Kelly JP, Navarrete JE, Casals MM, Kitabchi AE. Hyperglycemic crises in urban blacks. *Arch Intern Med*. 1997a;157(6):669–75.
- Umpierrez GE, Clark WS, Steen MT. Sulfonylurea treatment prevents recurrence of hyperglycemia in obese African-American patients with a history of hyperglycemic crises. *Diabetes Care*. 1997b;20(4):479–83.
- Umpierrez GE, Woo W, Hagopian WA, et al. Immunogenetic analysis suggests different pathogenesis for obese and lean African-Americans with diabetic ketoacidosis. *Diabetes Care*. 1999;22(9):1517–23.
- Umpierrez GE, DiGirolamo M, Tuvlin JA, Isaacs SD, Bhoola SM, Kokko JP. Differences in metabolic and hormonal milieu in diabetic- and alcohol-induced ketoacidosis. *J Crit Care*. 2000;15(2):52–9.
- Umpierrez GE, Latif K, Stoeber J, et al. Efficacy of subcutaneous insulin lispro versus continuous intravenous regular insulin for the treatment of patients with diabetic ketoacidosis. *Am J Med*. 2004a;117(5):291–6.
- Umpierrez GE, Cuervo R, Karabell A, Latif K, Freire AX, Kitabchi AE. Treatment of diabetic ketoacidosis with subcutaneous insulin aspart. *Diabetes Care*. 2004b;27(8):1873–8.
- Umpierrez GE, Smiley D, Kitabchi AE. Narrative review: ketosis-prone type 2 diabetes mellitus. *Ann Intern Med*. 2006;144(5):350–7.
- Umpierrez GE, Jones S, Smiley D, et al. Insulin analogs versus human insulin in the treatment of patients with diabetic ketoacidosis: a randomized controlled trial. *Diabetes Care*. 2009;32(7):1164–9.
- Vaarala O, Yki-Jarvinen H. Diabetes: should we treat infection or inflammation to prevent T2DM? *Nat Rev Endocrinol*. 2012;8(6):323–5.
- Vanelli M, Chiari G, Ghizzoni L, Costi G, Giacalone T, Chiarelli F. Effectiveness of a prevention program for diabetic ketoacidosis in children. An 8-year study in schools and private practices. *Diabetes Care*. 1999;22(1):7–9.
- Vellanki P, Smiley DD, Stefanovski D, et al. Randomized controlled study of metformin and Sitagliptin on long-term Normoglycemia remission in African American patients with Hyperglycemic crises. *Diabetes Care*. 2016;39(11):1948–55.
- Wilson HK, Keuer SP, Lea AS, Boyd AE 3rd, Eknayan G. Phosphate therapy in diabetic ketoacidosis. *Arch Intern Med*. 1982;142(3):517–20.
- Winter RJ, Harris CJ, Phillips LS, Green OC. Diabetic ketoacidosis. Induction of hypocalcemia and hypomagnesemia by phosphate therapy. *Am J Med*. 1979;67(5):897–900.
- Wrenn KD, Slovis CM, Minion GE, Rutkowski R. The syndrome of alcoholic ketoacidosis. *Am J Med*. 1991;91(2):119–28.
- Yamada K, Nonaka K. Diabetic ketoacidosis in young obese Japanese men. *Diabetes Care*. 1996;19(6):671.



Carmine G. Fanelli, Paola Lucidi, Geremia B. Bolli, and  
Francesca Porcellati

## Contents

Introduction .....	616
Frequency of Hypoglycemia .....	617
Definition of Hypoglycemia .....	619
Brain Metabolism and Glucosensors .....	620
Liver and Kidneys as Sources of Endogenous Glucose Production .....	622
Neuroendocrine Responses to Hypoglycemia .....	622
Pathophysiology of Hypoglycemia .....	625
Responses to Hypoglycemia in Elderly People .....	626
Impaired Awareness of Hypoglycemia (or Hypoglycemia Unawareness) .....	627
Hypoglycemia-Associated Autonomic Failure (HAAF – “Cryer Syndrome”) .....	627
Consequences of Hypoglycemia .....	629
Cardiovascular Risk of Hypoglycemia .....	629
The Economic Burden of Hypoglycemia .....	633
General Principles of Preventing Hypoglycemia .....	634
Prevention of Hypoglycemia in Intensively Treated Type 1 Diabetes .....	635
Prevention of Hypoglycemia in Intensively Treated Type 2 Diabetes .....	638
Treatment of Hypoglycemia Unawareness .....	639
Treatment of Hypoglycemia .....	641
Conclusions .....	641
References .....	641

## Abstract

Hypoglycemia rarely exists in humans outside diabetes mellitus treated with insulin and/or sulfonylureas. Because hypoglycemia produces marked discomfort, lasting for hours, and may progress to severe neuroglycopenia with cognitive

---

C. G. Fanelli · P. Lucidi · G. B. Bolli (✉) · F. Porcellati  
Section of Endocrinology and Metabolic Diseases, Department of Medicine, University of Perugia  
Medical School, Perugia, Italy  
e-mail: [carmine.fanelli@unipg.it](mailto:carmine.fanelli@unipg.it); [paola.lucidi3@gmail.com](mailto:paola.lucidi3@gmail.com); [geremia.bolli@unipg.it](mailto:geremia.bolli@unipg.it);  
[f.porcellati.fp@gmail.com](mailto:f.porcellati.fp@gmail.com)

dysfunction, unconsciousness, sometimes even epilepsy, it is highly feared by patients. Hypoglycemia may increase the cardiovascular risk of affected and/or elderly patients and is long-term associated with risk of dementia. In type 1 diabetes and also in those type 2 patients who lose  $\beta$ -cell function nearly totally, there is impaired response of glucagon to hypoglycemia which predisposes to a higher risk for hypoglycemia. In turn, recurrent hypoglycemia results in brain adaptation with loss of other counterregulatory hormones, primarily adrenaline, and symptom responses (hypoglycemia unawareness). This creates a vicious circle which predisposes to severe hypoglycemia. However, prevention of hypoglycemia in patients with hypoglycemia unawareness may recover both hormonal and symptoms responses to hypoglycemia thus reducing the risk for severe hypoglycemia. Prevention of hypoglycemia is, therefore, a key issue in insulin treatment. Education of patients, use of modern self-monitoring values of plasma glucose (SMPG) and continuous glucose monitoring (CGM) systems, and harmonization of rapid-acting and long-acting analogues of insulin (in place of human insulin) reduce the risk for hypoglycemia. To reduce the risk for hypoglycemia in type 2 diabetes, basal should be preferred to prandial insulin. If postprandial hyperglycemia requires treatment, glucagon-like peptide-1 receptor agonists (GLP-1RAs) should be added in place of prandial insulin, whenever possible. In addition, sulfonylureas should not be initiated and withdrawn, if in use, and dipeptidyl peptidase-4 (DPP-4) started instead. The optimal treatment of diabetes is the combination of an A1c level individualized for the personal characteristics of the patient and minimal risk for hypoglycemia.

---

**Keywords**

Hypoglycemia · Counterregulation · Intensive insulin therapy · Hypoglycemia unawareness · Continuous glucose monitoring system (CGMS)

---

**Introduction**

Hypoglycemia is the most common, and by far, the most feared, complication of antihyperglycemic treatment, particularly with insulin and sulfonylureas. Hypoglycemia is virtually absent with other treatments (insulin sensitizers, incretins, and gliflozins). Hypoglycemia is responsible for significant impairment of intellectual and physical activity and, if prolonged and/or severe, can lead to neuroglycopenia so marked as to result in seizures, coma, permanent neurological damage, and ultimately death. Even in cases of mild hypoglycemia (treated and resolved by the patient), cognitive dysfunction lasts for several tens of minutes after recovery of normoglycemia. Thus, patients who wish to drive a car or operate machinery should refrain from doing so for at least 1–2 h after hypoglycemia. Hypoglycemia increases the risk of cardiovascular events (Johnston et al. 2011; Desouza et al. 2010), dementia (Whitmer et al. 2009), fractures (Johnston et al. 2012), and overall mortality (McCoy et al. 2012). It also reduces quality of life (Green et al. 2012; Laiteerapong et al. 2011), generates fear of the antihyperglycemic treatment (Leiter et al. 2005), and, as a result, is a contributory cause of failure to

achieve good metabolic control. Directly and indirectly, hypoglycemia increases the expense of diabetes (Frier 2011). Prevention of risk of hypoglycemia is, therefore, a major goal that patients and diabetologists must continuously pursue in the course of therapy, especially if intensive. It follows that today, the definition of good glycemic control or optimized glycemic control not only means achieving and maintaining near-normal blood glucose with glycosylated hemoglobin <7.0% but also minimizing the risk of hypoglycemia. Consequently, healthcare providers should keep in mind not only the overall importance of the glycosylated hemoglobin level reached by a certain treatment but also the hypoglycemic risk that such therapy might pose for an individual with diabetes.

---

## Frequency of Hypoglycemia

**Type 1 diabetes.** While there is much information on the frequency of severe hypoglycemia, little is known on the real frequency of asymptomatic and mild hypoglycemia. This is because most episodes of severe hypoglycemia require assistance from a third party or admission to the hospital so that they are easily recalled by patients or their relatives. In contrast, episodes of mild hypoglycemia are usually treated by patients themselves or ignored, especially at night, so these episodes may be easily forgotten. As a consequence, the number of mild hypoglycemic episodes reported by patients is most likely to be underestimated. However, mild hypoglycemia, if recurrent, has relevant clinical implications. In fact, recurrent mild/moderate hypoglycemia over a short time induces unawareness of hypoglycemia and impairs glucose counterregulation. This, in turn, predisposes patients to severe hypoglycemia. The frequency of mild hypoglycemia may be estimated to be approximately 0.7–2 episodes/patient-week (UK Hypoglycemia Study Group 2007; Pedersen-Bjergaard et al. 2004).

In the Diabetes Control and Complications Trial (DCCT), the frequency of severe hypoglycemia, i.e., coma or hypoglycemia severe enough to require assistance from a third party, increased ~threefold in diabetic subjects treated with intensive insulin therapy as compared to subjects on “conventional” therapy (~0.6 vs. ~0.2 episodes/patient-year) (DCCT 1993). Similarly, in the Stockholm Diabetes Intervention Study, severe hypoglycemia was 2.5 times greater in those intensively treated patients (Reichard et al. 1993). In an observational study in the UK, the rate of severe hypoglycemia ranged from 1.1 to 3.2 episodes/patient-year according to insulin treatment duration (<15 years and >15 years, respectively) (UK Hypoglycemia Study Group 2007). This was substantially higher than that reported during the DCCT (1993), indicating that rates of hypoglycemia are often higher in unselected populations than in those in clinical trials where, almost always, people with risk factors for severe hypoglycemia (i.e., impaired awareness of hypoglycemia, previous severe hypoglycemia, and so on) are excluded. In fact, in a cross-sectional Danish-British multicenter survey of 1076 adult patients with clinical type 1 diabetes (T1DM), the incidence of severe hypoglycemia was 1.3 episodes/patient-year, whereas in a subgroup selected to be similar to the DCCT cohort, the rate of severe hypoglycemia was 0.35 episodes/patient-year (Pedersen-Bjergaard et al. 2004). In a multicenter,

observational retrospective Italian study, the incidence of severe hypoglycemia was 0.49 episodes/patient-year (Giorda et al. 2015). It is of note that in both these studies, the distribution of severe hypoglycemia was highly skewed with fewer subjects accounting for most of the episodes. Currently, the incidence of hypoglycemia is reduced thanks to the use of insulin analogues (as compared to the DCCT era when only human insulin was available), insulin pumps, and the implementation of structured education. The reductions are on the order of 15–75% in people with impaired awareness of hypoglycemia, who usually experience most episodes of severe hypoglycemia. The reductions for those people are coupled with improvement in their awareness of hypoglycemia (Yeoh et al. 2015).

**Type 2 diabetes.** In type 2 diabetes (T2DM), the rates of severe hypoglycemia are reported to be lower than in T1DM (Cryer 2016). On a pathophysiological basis, this is not surprising. T2DM is characterized by insulin resistance, persistent  $\beta$ -cell function in the early phase (although with impaired response to carbohydrate meals) which allows insulin secretion to decrease as blood glucose falls, and apparently, intact or increased counterregulation, at least in the early phase (Cryer et al. 2003; Spyer et al. 2000; Gerich 2000). Accordingly, results of several large studies report lower rates of severe hypoglycemia in T2DM. The Kumamoto study, which evaluated insulin-treated nonobese type 2 patients, did not report episodes of severe hypoglycemia over 8 years of observations (Shichiri et al. 2000). In other studies such as the VA Cooperative Study (Abaira et al. 1998) and the UK Prospective Diabetes Study (UKPDS) (the UKPDS Research Group 1995), the frequency of severe hypoglycemia was much lower than that reported in the DCCT. However, it is of note that in the UKPDS study, the frequency of hypoglycemia increased over time with prolonged duration of insulin treatment (the UKPDS Research Group 1998). However, in other studies the incidence of severe hypoglycemia was found to be elevated in T2 as with T1DM after matching for duration of insulin therapy (Hepburn et al. 1993). Thus, the risk of hypoglycemia increases in insulin-treated T2DM of long duration. There is pathophysiological evidence that patients with advanced type 2 diabetes and longer duration of insulin treatment have reduced glucagon, lower sympathoadrenal responses to insulin-induced hypoglycemia, and almost absent C-peptide concentrations (Segel et al. 2002). Patients with type 2 diabetes of long duration become similar to hypoglycemia-prone type 1 patients.

In the international literature, the number of events of severe hypoglycemia in type 2 diabetes varies from 0 to 0.73 episodes per patient-years (Cryer 2016). A number of variables are recognized as related to episodes of hypoglycemia. In general, the risk of hypoglycemia increases with advancing age, regardless of the degree of glycemic control. A prospective observational study of 3810 patients with type 2 diabetes on oral medications and with similar levels of glycated hemoglobin (7.3–7.6%) showed that the percentage of patients with hypoglycemia, of varying severity, was directly proportional to the age of patients (9% of those age <60 years old, 10.1% of those aged 60–69 years, and 12.8% of those age  $\geq$ 70 years) (Bramlage et al. 2012). The risk of severe hypoglycemia increases with the intensification of glycemic control (the UKPDS Research Group 1998). The Action to Control Cardiovascular Risk in Diabetes (ACCORD), Action in



Diabetes and Vascular Disease: Preterax and Diamicon MR Controlled Evaluation (ADVANCE), and Veterans Affairs Diabetes Trial (VADT) trials, three large clinical trials that compared cardiovascular risk in type 2 people with diabetes receiving either “intensive” or “conventional” diabetes treatment, showed incidence rates for severe hypoglycemia in the intensive insulin group ranging from 0.7 to 12 events/100 person-years. The risk of severe hypoglycemia increases also in patients with long duration of disease and with the use of insulin and sulfonylureas (Bramlage et al. 2012; Giorda et al. 2014).

---

## Definition of Hypoglycemia

Hypoglycemia in people with diabetes includes all episodes of an abnormally low plasma glucose concentration that expose the individual to potential harm (Workgroup on Hypoglycemia, American Diabetes Association [ADA] 2005; Seaquist et al. 2013). Hypoglycemia in diabetes is classified into five distinct categories: (1) *severe hypoglycemia*, (2) *documented symptomatic hypoglycemia*, (3) *asymptomatic hypoglycemia*, (4) *probable symptomatic hypoglycemia*, and (5) *pseudohypoglycemia* (Workgroup on Hypoglycemia ADA 2005; Seaquist et al. 2013) (Table 1).

Even though it is not straightforward to set a single glucose level for defining hypoglycemia because glycemic thresholds for symptoms of hypoglycemia (and glucose counterregulation) are affected by the prevailing plasma glucose levels with the result of shifting to lower plasma glucose concentrations after recent antecedent hypoglycemia (Heller and Cryer 1991; Veneman et al. 1993; Dagogo-Jack and Cryer 1993; Ovalle et al. 1998), an alert value has been defined in order to classify hypoglycemia and to draw the attention of both patients and caregivers (Workgroup on Hypoglycemia ADA 2005). Such value has been set at a self-monitored plasma glucose, or continuous glucose monitoring (CGM) subcutaneous glucose, of  $\leq 70$  mg/dL ( $\leq 3.9$  mmol/L). This threshold may be considered somewhat conservative (too high), but it has the advantage of allowing time to prevent a clinical hypoglycemic episode and provides some margin for the limited accuracy of monitoring devices at low-glucose levels (Workgroup on Hypoglycemia ADA 2005). Especially during intensive insulin treatment, it provides safer margins in order to achieve the planned glycemic targets. Such an alert value defines hypoglycemia in children as well (Ly et al. 2014) and has been accepted by the main regulatory agencies such as FDA (2008) and EMA (2012). Recently, it has been recommended that a blood glucose of 54 mg/dL (3.0 mmol/L) as detected by either SMBG, CGM (for at least 20 min), or laboratory measurement of plasma glucose should be considered sufficiently low to indicate serious, clinically significant hypoglycemia that should be included in reports of clinical trials of glucose-lowering drugs for the treatment of diabetes. This would enable the capture of hypoglycemic episodes that have greater clinical relevance and the comparison of the effectiveness of interventions in reducing such events in clinical trials. Possible terms used to describe this condition include “serious,” “clinically important,” “major,” or “clinically significant” (International Hypoglycemia Study Group 2017) (Table 1).

**Table 1** The American Diabetes Association and the Endocrine Society classification of hypoglycemia in diabetes

---

**Severe hypoglycemia.** An event requiring assistance of another person to actively administer carbohydrate, glucagon, or other resuscitation actions. Plasma glucose measurements may not be available during such an event, but neurological recovery attributable to the restoration of plasma glucose to normal is considered sufficient evidence that the event was induced by a low plasma glucose concentration

---

**Documented symptomatic hypoglycemia.** An event during which typical symptoms of hypoglycemia are accompanied by a measured plasma glucose concentration  $\leq 70$  mg/dL ( $\leq 3.9$  mmol/L)

---

**Asymptomatic hypoglycemia.** An event not accompanied by typical symptoms of hypoglycemia but with a measured plasma glucose concentration  $\leq 70$  mg/dL ( $\leq 3.9$  mmol/L)

---

**Probable symptomatic hypoglycemia.** An event during which symptoms typical of hypoglycemia are not accompanied by a plasma glucose determination but that was presumably caused by a plasma glucose concentration  $\leq 70$  mg/dL ( $\leq 3.9$  mmol/L)

---

**Relative hypoglycemia (or pseudohypoglycemia).** An event during which the person with diabetes reports any of the typical symptoms of hypoglycemia and interprets those as indicative of hypoglycemia with a measured plasma glucose concentration  $> 70$  mg/dL ( $> 3.9$  mmol/L) but approaching that level

---

**The Joint Position Statement of the American Diabetes Association and the European Association for the Study of Diabetes**

---

A glucose level of 54 mg/dL (3.0 mmol/L) is sufficiently low to indicate serious, clinically important hypoglycemia

---

Adapted from the following references: Workgroup on Hypoglycemia, American Diabetes Association [ADA] 2005; Seaquist et al. 2013; International Hypoglycemia Study Group 2017

---

## Brain Metabolism and Glucosensors

The transport of circulating glucose into cerebral cells is an insulin-independent process that requires the presence of facilitative glucose transport proteins. The result is that there is a linear relationship between plasma glucose concentrations and brain glucose levels (Gruetter et al. 1998). Recently, this relationship has been documented also in the hypoglycemic range in healthy subjects and in subjects with type 1 diabetes (van de Ven et al. 2012). By extrapolating this linear relationship below plasma levels of approximately 45 mg/dL (2.5 mmol/L), brain glucose approaches zero at a plasma glucose level of approximately 21 mg/dL (1.2 mmol/L) (van de Ven KC et al. 2012).

The first glucose transporter in this process is the glucose transporter 1 (GLUT1) (55-kDa form), localized in microvessels of the blood-brain barrier. It moves glucose from the capillary lumen to the brain interstitium. Once glucose reaches the interstitium, it is transported into neurons and glial cells via the GLUT3 and GLUT1 (45-kDa form) transporters (Vannucci et al. 1997). The expression of GLUT1 in the microvessels' endothelium may be regulated, in part, by prevailing antecedent systemic glucose concentration. Indeed, brain glucose transport and utilization as well as the expression of GLUT1 (55-kDa form) have been found to be increased in chronically hypoglycemic rats (McCall et al. 1986). In addition, the

expression of GLUT3 protein, the neuron-specific glucose transporter, is also increased following chronic insulin-induced hypoglycemia in rats (Uehara et al. 1997). The upregulation of glucose transporter expression described in animals may be relevant to the clinical phenomenon of hypoglycemia unawareness in humans (Fanelli et al. 1993a; Boyle et al. 1995).

In the last few years, research has focused on the role of substrates other than glucose, such as lactate, and brain glycogen metabolism and on their role in sustaining brain function under conditions of energy depletion such as neuroglycopenia. It is of interest that during insulin-induced hypoglycemia ( $\sim 54$  mg/dL; 3 mmol/L), studies in healthy subjects using cross-brain arteriovenous differences for plasma glucose, lactate, alanine, and leucine have shown that brain lactate increases, but the energy deriving from its metabolism is not sufficient (only 25%) to offset the brain glucose energy deficit (Lubow et al. 2006). These data suggest that the physiological elevation of endogenous lactate production during hypoglycemia (and consequent increase in brain glucose uptake) is inadequate to satisfy the loss in brain energy metabolism from reduced glucose uptake (Lubow et al. 2006).

The function of brain glycogen is not well understood. It might be the source of lactate (Wender et al. 2000) to be taken up and used by neurons. Overall glycogen content is low ( $7.8 \pm 0.3$   $\mu\text{mol/g}$ ) (Öz et al. 2015), although substantially higher than previous estimates of glycogen content in the human brain ( $\sim 3$   $\mu\text{mol/g}$ ) (Clarke and Sokoloff 1994; Choi et al. 2003). It has been suggested that even under normal conditions, cerebral glycogen may be important for brain function (Clarke and Sokoloff 1994). In humans, brain glycogen is used during hypoglycemia, and its content increases above normal levels (“supercompensates”) after hypoglycemia (Öz et al. 2009). Although, evidence indicate that supercompensated brain glycogen levels do not contribute to the development of hypoglycemia unawareness in people with type 1 diabetes (Öz et al. 2012).

The brain is considered the prominent center for the sensing of hypoglycemia (Di Rocco and Grill 1979; Frohman and Nagai 1976; Ritter et al. 1981; Shimazu et al. 1966), although glucose-sensing cells are also located in the periphery (Donavan and Watts 2014). Although glucose sensors are located in many areas in the brain, the hypothalamus, particularly the ventromedial hypothalamus (VMH), seems to be the main structure involved in glucose sensing (Routh 2003). Induction of systemic hypoglycemia during prevention of VMH glucopenia suppressed the release of counterregulatory hormones by  $\sim 85\%$  (Borg et al. 1997). Glucose-sensing neurons have been described in the ventromedial hypothalamic (VMH) nucleus of the hypothalamus which interacts through a convergence of pre- and postsynaptic influences (Routh 2003; Song et al. 2001). Two of these subtypes of glucose-sensing neurons are known as glucose-excited (GE) and glucose-inhibited (GI) neurons, the action potential frequencies of which are increased and reduced, respectively, by an increase in extracellular glucose (Routh 2002; Levin 2002). GE neurons require ATP-sensitive  $\text{K}^+$  ( $\text{K}_{\text{ATP}}$ ) channels in order to sense glucose (Routh 2010) and to activate glucose counterregulation (Evans et al. 2004; Beall et al. 2012; Chan and Sherwin 2013). (For detailed review of functional and metabolic neuroimaging techniques and cerebral metabolism during hypoglycemia, see Rooijackers et al. 2016.)

## Liver and Kidneys as Sources of Endogenous Glucose Production

Because maintenance of plasma glucose above the threshold of hypoglycemia is critical for survival of the whole body, organs which normally release glucose into circulation, namely, the liver and kidneys, play a key physiological role in supporting brain function. Nearly all tissues, to varying degrees, oxidize glucose to derive energy for metabolic demands. Yet only the liver and kidneys release glucose after its storage as glycogen (liver) or synthesis (liver and kidneys). The glucose release results from the presence in these organs of glucose-6-phosphatase which liberates glucose into the bloodstream. The liver and kidneys do not, however, contribute equally to postabsorptive glucose homeostasis. It is generally believed that the liver makes the major quantitative contribution, while the kidneys play a minor role (Cahill et al. 1966). On the other hand, it is estimated that the kidneys may contribute almost half of total endogenous glucose production during prolonged starvation (Cahill 1970; Owen et al. 1969). The mechanism of renal glucose production in the postabsorptive state and under circumstances such as hypoglycemia is through gluconeogenesis primarily from glutamine (and other amino acids), lactate, and glycerol (Cersosimo et al. 1994, 1999a; Stumvoll et al. 1998a).

Insulin suppresses renal glucose release yet stimulates renal glucose utilization (Cersosimo et al. 1994, 1999). The effects of insulin on renal glucose turnover may be mediated, in part, by suppression of lipolysis (Cersosimo et al. 1999a; Meyer et al. 1997). Epinephrine infusions which raise plasma epinephrine concentrations to a level similar to that observed during hypoglycemia increase renal glucose production (Stumvoll et al. 1995), whereas glucagon infusions have no such effect in post-absorptive humans (Stumvoll et al. 1998b). In support of this view, data suggests renal glucose production is enhanced during mild hypoglycemia (Cersosimo et al. 1997), contributing approximately one third of systemic glucose production in humans (Cersosimo et al. 1999b).

An interesting concept has been developed in the past few years regarding the relative contribution of the liver and kidneys in glucose production in order to maintain normoglycemia; this mechanism has been defined as hepatorenal reciprocity (Gerich 2003). The fundamental concept is that in several physiological and pathological conditions, the impairment of either hepatic or renal glucose release is compensated by an increase in glucose release by one of these two organs (Gerich 2003). Although it is unlikely that hepatorenal reciprocity occurs in type 1 diabetes during hypoglycemia (Bolli 1990), it has been documented in type 2 diabetes where increased renal glucose release compensates for reduced hepatic glucose release during counterregulation of hypoglycemia (Woerle et al. 2003).

---

## Neuroendocrine Responses to Hypoglycemia

Maintenance of plasma glucose concentration above a given threshold is crucial for brain function (and survival of the whole body). Multiple mechanisms cooperate to prevent hypoglycemia in humans, especially under adverse conditions, such as

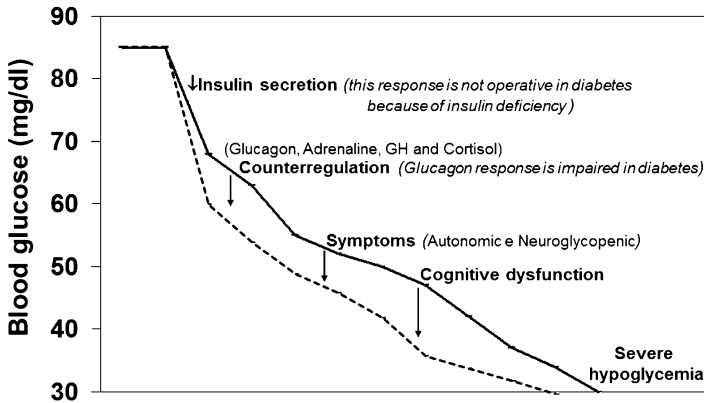

**Fig. 1** Neuroendocrine responses to hypoglycemia and glycemic threshold for their activation in the normal setting (bold line) and following recurrent hypoglycemia which shifts the glycemic threshold for these responses to lower plasma glucose concentrations (dashed line). To convert plasma glucose concentration to mmol/L, divide values in mg/dL by 18

prolonged fasting, failure of vital organs (kidneys, heart, liver), or after administration of glucose-lowering drugs. These protective mechanisms include, first, activation of counterregulatory hormones (Bolli 1990; Bolli and Fanelli 1999); second, generation of specific symptoms (Towler et al. 1993) which trigger, and, third, a behavioral defense most likely mediated by the activation of the NPY/AGRP neurons in the arcuate nucleus of the hypothalamus which has an orexigenic effect and promote food intake (Coiro et al. 2011).

These responses are hierarchic (Mitrakou et al. 1991) (Fig. 1). In the hierarchy of counterregulation studied in physiology of normal, nondiabetic subjects (Fanelli et al. 1994b), the first mechanism is suppression of endogenous insulin secretion which limits portal hyperinsulinemia thereby rendering the effects of counterregulatory hormones more efficient. The second mechanism is an increased secretion in counterregulatory hormones which contribute to the defense against hypoglycemia, although different hormones may be important at different times (early and/or late phase) and involve different mechanisms (increase in glucose production, suppression of glucose utilization, or both) (De Feo et al. 1986) (Fig. 2). In addition, a greater availability of substrates (e.g., free fatty acids) contributes, at least in part, to the counterregulation of hypoglycemia (Fanelli et al. 1993b). The third mechanism is the activation of behavioral responses aimed at correction of hypoglycemia by ingestion of carbohydrates. Generation and perception of symptoms of hypoglycemia are fundamental steps in this third defensive mechanism to hypoglycemia.

Symptoms of hypoglycemia are categorized as autonomic (anxiety, palpitations, and tremor, which are catecholamine-mediated, and hunger, sweating, and paresthesias, which are acetylcholine mediated) (Towler et al. 1993) and neuroglycopenic (dizziness, tingling, blurred vision, difficulty in thinking, and faintness). Research indicates that autonomic symptoms are largely the result of sympathetic neural, rather than adrenomedullary, activation (DeRosa and Cryer 2004).

Acute hypoglycemia		LIVER					
	Glycogenolysis	Gluconeogenesis					
Glucagon	↑	↑					
Adrenaline	↑	↑					

Prolonged hypoglycemia		LIVER		MUSCLE		FAT	
	Glycogenolysis	Gluconeogenesis	Glycogenolysis Glycolysis	Proteolysis	Lipolysis		Glucose Utilization
Glucagon	↑	↑					
Adrenaline	↑	↑	↑	↑	↑		↓
Cortisol	↑	↑	↑	↑	↑		↓
GH	↑	↑				↑	↓

Lactate	Amino acids	Glycerol
---------	-------------	----------

**Fig. 2** Main metabolic effects of counterregulatory hormones during acute (top panel) and prolonged (bottom panel) hypoglycemia. ↑ = increase; ↓ = decrease

Counterregulatory hormones (glucagon, adrenaline, cortisol, and growth hormone) are released at a (arterial) plasma glucose threshold of approximately 65 mg/dL ( $\sim 3.5$  mmol/L); symptoms (both, autonomic and neuroglycopenic) appear only when plasma glucose decreases at approximately 54–50 mg/dL ( $\sim 3.0$ – $2.8$  mmol/L) and cognitive function deteriorates at plasma glucose concentrations of  $\sim 52$ – $45$  mg/dL ( $\sim 2.9$ – $2.5$  mmol/L) (Mitrakou et al. 1991; Fanelli et al. 1994b). However, as mentioned above, these glucose thresholds are not fixed but rather dynamic and affected by antecedent prevailing ambient plasma glucose such that glucose thresholds shift downward (i.e., at lower plasma glucose concentrations) after recent antecedent hypoglycemia, either recurrent or chronic (Fanelli et al. 1994a, 1997, 1998; Mitrakou et al. 1993; Fruehwald-Schultes et al. 2000; Veneman 1993; Hvidberg 1996; Ovalle et al. 1998; Heller and Cryer 1991; Veneman et al. 1993; Dagogo-Jack and Cryer 1993) (Fig. 1). As a consequence, responses to hypoglycemia require plasma glucose to reach levels lower than usual. This increases the risk of brain dysfunction and severe hypoglycemia (Fanelli et al. 2002).

The importance of this observation stems from the fact that patients may or may not experience symptoms of hypoglycemia, depending on their recent, antecedent blood glucose control. For example, if patients had recurrent (i.e., daily) episodes of hypoglycemia, it is likely that they would not be able to recognize hypoglycemia at all or possibly become aware of it at lower than usual plasma glucose concentration (54–50 mg/dL). However, if hypoglycemia is prevented for a few days, patients may

recover symptoms and recognize hypoglycemia at a physiological plasma glucose threshold (Fanelli et al. 1993a). On the other hand, people with poorly controlled diabetes, frequently hyperglycemic, have thresholds for these responses shifted upward at higher than normal glucose levels (Boyle et al. 1988).

---

## Pathophysiology of Hypoglycemia

Therapeutic hyperinsulinemia, either absolute or relative, as a result of exogenous insulin during insulin therapy or following insulin secretagogue therapy is the initiating cause of hypoglycemia in diabetes. In fact, hyperinsulinemia is common in diabetes mellitus, both type 1 and type 2 (T2DM), because of the therapeutic delivery of insulin into peripheral rather than portal circulation. However, when T1DM patients and nondiabetic subjects are experimentally exposed to similar hyperinsulinemia, hypoglycemia is more severe and prolonged in the former (Bolli et al. 1984b). Clearly, the defense mechanisms against hypoglycemia are impaired in T1DM (Bolli 1990). The most common defect is impaired glucagon response to hypoglycemia (Bolli 1990). Even in adolescents with recent-onset, type 1 diabetes mellitus glucagon responses to hypoglycemia are blunted within the first year of T1DM, but epinephrine responses are not (Arbelaez et al. 2014). Loss of glucagon response to hypoglycemia in people with type 1 diabetes appears to be a deficit of the  $\alpha$ -cell selective for hypoglycemia. In fact, response to non-glucose stimuli such as the amino acids arginine, alanine, and a mixture of amino acids is largely maintained (Rossetti et al. 2008a). Currently, the mechanism(s) behind the defective secretion of glucagon to hypoglycemia in people with type 1 diabetes is (are) not known. The physiological decrease in endogenous insulin secretion from the  $\beta$ -cell, occurring when hypoglycemia develops, is a mechanism believed to be necessary in order for glucagon to be released by the  $\alpha$ -cell. This mechanism, known as intra-islet insulin hypothesis, is altered in diabetes because of the loss of  $\beta$ -cell mass and function which is thought to blunt the response of glucagon to hypoglycemia (Cryer 2005). Although, insulin may act in the VMH to inhibit glucagon secretion from the  $\alpha$ -cell (Paranjape et al. 2010). Under these conditions, it is the response of the remaining rapid counterregulatory hormone adrenaline, which is critical for counterregulation (Bolli 1990). Unfortunately, however, many T1DM patients also suffer from reduced responses of adrenaline, especially after recurrent hypoglycemia (Fanelli et al. 1993a), and/or in the presence of the duration of T1DM greater than 10–20 years (Fanelli et al. 1997). The combined defects of absent glucagon secretion and reduced adrenaline response in the setting of therapeutic hyperinsulinemia lead to the clinical syndrome of defective glucose counterregulation which represents a strong determinant of future severe hypoglycemic episodes during intensive insulin therapy (White et al. 1983; Bolli et al. 1984a).

Hypoglycemia in T2DM is less frequent than in T1DM because of insulin resistance, and intact counterregulation, at least in people with a short duration of diabetes. As diabetes duration increases and  $\beta$ -cell function deteriorates substantially, glucagon responses to hypoglycemia may become impaired similarly to

T1DM (Segel et al. 2002; UK Hypoglycemia Study Group 2007). In addition, antecedent hypoglycemia reduces autonomic and symptomatic responses to subsequent hypoglycemia in T2DM, likewise in T1DM (Segel et al. 2002). Therefore, hypoglycemia may occur in T2DM, especially if treatment is directed at achieving the goals of intensive therapy (Gerstein et al. 2008; Patel et al. 2008; Duckworth et al. 2009). Hypoglycemia may occur as a consequence of both, insulin and sulfonylurea treatment, respectively.

## Responses to Hypoglycemia in Elderly People

Elderly people are more likely to develop iatrogenic hypoglycemia than non-elderly people (Bremer et al. 2009). One reason is that healthy elderly people may have blunted release of glucagon and adrenaline in response to hypoglycemia and reduced awareness of the autonomic symptoms of hypoglycemia as compared to younger people (Meneilly et al. 1994). The difference between the glucose level for subjective awareness of hypoglycemia and the onset of cognitive dysfunction (as measured by four-choice reaction time) is substantially lost in the older (60–70 years) as compared to the young (22–26 years) (Matyka et al. 1997). As a result, in older patients during falling blood glucose, cognitive dysfunction may present at the same time as perception of alerting symptoms of hypoglycemia, thus interfering with the defensive behavioral response of ingesting carbohydrates. In addition, in elderly people with type 2 diabetes treated with insulin, it has been shown that the expression and perception of hypoglycemic symptoms are different from those seen in younger diabetic people (Jaap et al. 1998). In one study, hormonal, symptoms, and cognitive responses (reaction time) were tested during 30-min steady-state hypoglycemia at a level of 50 mg/dL (2.8 mmol/L) in 13 older (> or = 65 years) and 13 middle-aged (39–64 years) type 2 diabetic patients. Hormonal counterregulatory responses to hypoglycemia did not differ between older- and middle-aged patients. In contrast, middle-aged patients showed a pronounced increase in autonomic and neuroglycopenic symptom scores at the end of the hypoglycemic plateau that was not observed in older patients. In addition, only one older participant correctly estimated their blood glucose concentration to be <59 mg/dL (<3.3 mmol/L) during hypoglycemia. Cognitive dysfunction (prolongation of reaction times) tended to be greater in the elderly people (Bremer et al. 2009). It is interesting to note that not only does hypoglycemia cause cognitive dysfunction, but severe cognitive dysfunction doubles the risk of severe hypoglycemia (de Galan et al. 2009). In that regard, an additional factor interfering with hypoglycemia recognition and treatment in older people with diabetes is that generalized cognitive impairment occurs more frequently in the elderly. In one study, people with type 2 diabetes treated with insulin, aged 75 years and over, were, by and large, able to manage their diabetes with insulin correctly and to identify the steps to be taken in the event of low blood sugar (ingestion of sugary snacks or drink), although a subgroup of individuals with cognitive impairment, who formed approximately one quarter of the larger group, were significantly more likely to be confused about what to do and were more prone



to increase their treatment (Hewitt et al. 2011). A practical consideration that cannot be disregarded, based on the results of these studies, is that in older people, hypoglycemia may be misdiagnosed. In fact, hypoglycemia may go undetected and may present with non-specific symptoms such as dizziness, visual disturbance, or unsteadiness (Jaap et al. 1998) or, because of the precocious neurological and cognitive impairment, with cerebrovascular, neurological, or cognitive dysfunction signs.

### **Impaired Awareness of Hypoglycemia (or Hypoglycemia Unawareness)**

It has been estimated that in 17–36% of people with type 1 diabetes, perception of alerting symptoms of hypoglycemia is blunted and becomes more impaired as duration of diabetes increases (>30 years) (DCCT 1991; Gerich et al. 1991; Geddes et al. 2008; Olsen et al. 2014). In type 2 diabetes, about 6–8% of people develop such a condition, with it being more frequent in those in intensive therapy (Henderson et al. 2003; Seaquist et al. 2012). Impaired perception of symptoms of hypoglycemia in people with type 1 diabetes is largely the result of antecedent, frequent hypoglycemia which blunts adrenaline response resulting in attenuated, unperceived symptoms of hypoglycemia causing impaired awareness of hypoglycemia (or hypoglycemia unawareness). Under conditions of impaired awareness of hypoglycemia, the protective behavior of ingesting sugars in order to prevent progression to a more severe form of hypoglycemia is disrupted, thus exposing subjects to a higher risk of severe hypoglycemia. Indeed, under such circumstances the estimated risk of iatrogenic severe hypoglycemia is increased by sixfold in type 1 diabetes (Gold et al. 1994; Geddes et al. 2008) and by ninefold in type 2 diabetes (Henderson et al. 2003).

### **Hypoglycemia-Associated Autonomic Failure (HAAF – “Cryer Syndrome”)**

Experimental studies in healthy subjects have shown that two episodes of mild and brief insulin-induced hypoglycemia ( $\sim 50$  mg/dL,  $\sim 2.7$  mmol/L for  $\sim 90$  min, one episode in the morning, the other in the afternoon) (Heller and Cryer 1991), or a single episode of nocturnal hypoglycemia (Hvidberg et al. 1996; Veneman et al. 1993), blunt the hormonal (including adrenaline) and symptom responses to hypoglycemia induced on the following day. Similar observations have been made in type 1 (Fanelli et al. 1998; Dagogo-Jack and Cryer 1993) and in advanced type 2 diabetes (Segel et al. 2002).

Further research has established that meticulous prevention of hypoglycemia in people with type 1 diabetes previously experiencing nearly one episode of hypoglycemia per day is followed by rapid recovery of symptoms (both autonomic and neuroglycopenic) and counterregulatory responses (in particular adrenaline) (Fanelli

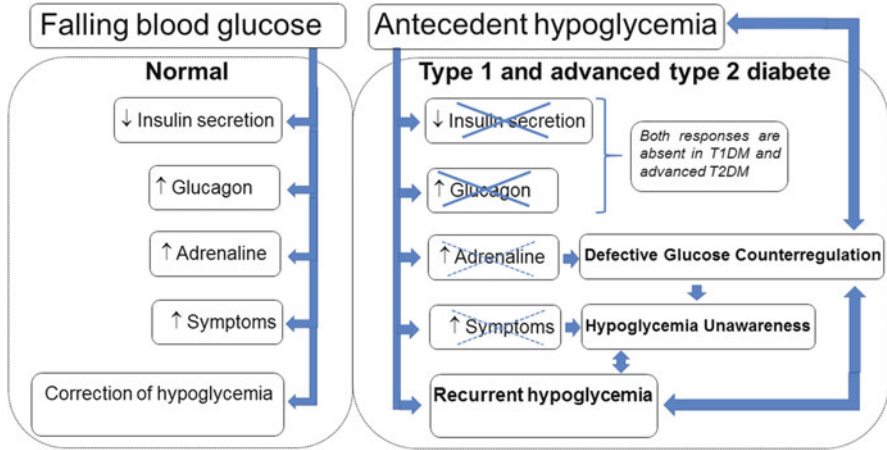

**Fig. 3** Counterregulatory hormone and symptom responses in the normal setting (left panel) and in HAAF (Cryer syndrome) (right panel) in type 1 and advanced type 2 diabetes

et al. 1993a). Similar results have subsequently been confirmed in people with longer duration of diabetes (Fanelli et al. 1994a; Cranston et al. 1994; Dagogo-Jack et al. 1994). Based on these unique findings, Cryer has proposed the concept of hypoglycemia-associated autonomic failure (HAAF) in diabetes, speculating that recently, antecedent hypoglycemia is the primary cause of both defective glucose counterregulation and impaired awareness of hypoglycemia, setting up a vicious cycle in which antecedent hypoglycemia can induce subsequent hypoglycemia (Heller and Cryer 1991; Cryer 2005, 2013, 2016; Segel et al. 2002) (Fig. 3). In fact, recurrent hypoglycemia occurs unavoidably from time to time in the setting of iatrogenic hyperinsulinemia, due to imperfect insulin replacement, and deficient glucagon response to hypoglycemia (Bolli 1990), causing impaired secretion of adrenaline and hypoglycemia unawareness. Both, impaired adrenaline secretion and hypoglycemia unawareness, in turn, foster recurrent hypoglycemia (Cryer 1992, 2001). HAAF is largely a functional disorder distinct from classic diabetic autonomic neuropathy (Dagogo-Jack and Cryer 1993). In fact, the loss of adrenaline response to hypoglycemia is not necessarily the result of autonomic neuropathy, although autonomic neuropathy may contribute to this. In addition, the prevention of hypoglycemia reverses hypoglycemia unawareness in people with autonomic neuropathy but only marginally improves adrenaline responses (Fanelli et al. 1997). Interestingly, prior hypoglycemia impairs autonomic control of cardiovascular function (Adler et al. 2009). In addition to antecedent hypoglycemia, HAAF, nowadays known as “Cryer syndrome” (Dagogo-Jack 2015), is induced also by exercise and sleep (Cryer 2004, 2009; Banarer and Cryer 2003).

The mechanisms responsible for the development of HAAF (syndrome with loss of counterregulatory hormone and symptom responses to hypoglycemia induced by recent antecedent hypoglycemia) have been the focus of much research, although they are not yet fully understood. For the key elements of hypoglycemia-related

HAAF, i.e., defective counterregulation and impaired awareness of hypoglycemia, evidence supports hypotheses that include increased blood-to-brain glucose transport (or alternative fuel), effects of a systemic mediator such as cortisol on the brain, reduced beta-adrenergic sensitivity (Fritsche et al. 2001), altered hypothalamic mechanisms, and activation of an inhibitory cerebral network mediated through the thalamus (for detailed review of mechanisms, see Cryer 2005, 2013). Although the mechanisms have so far not yet been established, clearly prevention and treatment of HAAF remain an important goal of diabetes treatment to reduce the risk for severe hypoglycemia.

---

## Consequences of Hypoglycemia

In addition to causing HAAF, hypoglycemia, depending on its severity, duration, and frequency (acute vs. recurrent), and the presence of comorbidities, can cause other feared consequences, ranging from *psychological to neurological to cognitive* and/or *cardiovascular* (Seaquist et al. 2013). Psychological consequences, in the short-term, may be anxiety, irritability, depression, and/or embarrassment, while long-term there may be stress, fear of hypoglycemia (which may be a barrier to achieving good glycemic control), conflicts in relationships, work/school environment problems, or social isolation. The neurological consequences can include coma, transient hemiplegia, convulsions, and the damage that can directly follow from these such as trauma and fractures. The long-term impact of hypoglycemia on cognitive function is not completely ascertained, and many factors, such as age of onset, duration of diabetes, degree of glucose control, microvascular complications, and so on, may affect its real impact on cognitive function. In the DCCT/EDIC study, the increased frequency of severe hypoglycemia in patients on intensive insulin therapy was not associated with cognitive deficits in patients who were followed for an average of 18 years (DCCT/EDIC Study Research Group 2007). Instead, cognitive deficits associated with a higher frequency of severe hypoglycemia were demonstrated in children in whom hypoglycemia presented before age 5 (Hershey et al. 2005). These data suggest that the brains of young children in development are most vulnerable to the deleterious effects of severe hypoglycemia. In the elderly with type 2 diabetes, hypoglycemia can be associated with dementia (Whitmer et al. 2009). This in turn may be associated with increased risk of hypoglycemia (Yaffe et al. 2013).

---

## Cardiovascular Risk of Hypoglycemia

Over the last decade, emphasis has been given to the possible connection between hypoglycemia and cardiovascular risk. Several epidemiological studies and smaller prospective studies have linked hypoglycemia to increased cardiovascular risk (Judson and Hollander 1956; Egeli and Berkmen 1960; Fisman et al. 2004). Recent large randomized trials looking at intensive glycemic control in T2DM have either shown no benefit for cardiovascular risk (ADVANCE and VADT) or increased

all-cause mortality (ACCORD) (Skyler et al. 2009). While the reason for the increased mortality is unclear and hypoglycemia has not been definitively implicated as a cause of death, these studies have increased the debate about the degree of glycemic control required to decrease diabetes complications and the role of hypoglycemia in cardiovascular morbidity and mortality.

Observations about the relationship between hypoglycemia and cardiac events are controversial. In a retrospective review of 14,670 patients with coronary artery disease (CAD), recruited for the Bezafibrate Infarction Prevention Study over an 8-year mean follow-up, hypoglycemia (<70 mg/dL) was a predictor of increased all-cause mortality with a hazard ratio (HR) of 1.84, but not of increased CAD mortality (Fisman et al. 2004). In contrast, in the Bypass Angioplasty Revascularization Investigation 2 Diabetes (BARI 2D) trial, although severe hypoglycemia was more frequent in the insulin-provision group (9.2%) than in the insulin-sensitization group (5.9%), major cardiovascular events were not significantly different (Frye et al. 2009).

A few studies using continuous EKG monitoring and glucose monitoring have been done recently. Desouza et al. demonstrated that of 54 episodes of hypoglycemia, 10 were associated with symptoms or EKG evidence of ischemia, whereas only 1 episode of chest pain occurred during 59 episodes of hyperglycemia (Desouza et al. 2003). Less studied is the “dead-in-bed” syndrome, which is defined as the sudden nocturnal death in type 1 diabetes (Tattersall and Gill 1991). Gill et al. demonstrated that in patients with type 1 diabetes, severe hypoglycemia was associated with a prolonged corrected QT interval. Eight of those episodes also showed cardiac rate and rhythm abnormalities, respectively (Gill et al. 2009).

Recently, several large randomized trials evaluating the effects of glycemic control on cardiovascular events have published their results (Gerstein et al. 2008; Patel et al. 2008; Duckworth et al. 2009). The ACCORD trial randomized 10,251 participants with a history of cardiovascular events or significant cardiovascular risk to a strategy of intensive glycemic control or standard glycemic control (Gerstein et al. 2008). The ACCORD trial was halted due to a significant increase in all-cause mortality (22%) and cardiovascular mortality (35%) in the intensive treatment group. In both, the intensive and standard treatment arms, participants with severe hypoglycemia had a higher mortality rate than those without severe hypoglycemia (Gerstein et al. 2008). However, the association between hypoglycemia and mortality is complex in this study, since the relative risk of death due to severe hypoglycemia was 1.28 for the intensive arm versus 2.87 for the standard arm in spite of larger number of severe hypoglycemic episodes in the former. This suggests that severe hypoglycemia in a certain subset of patients may be a factor in mortality more than the strategy of treatment used (intensive vs. standard). The subset of patients most prone to the detrimental effects of hypoglycemia was older and had longer duration of diabetes, higher HbA1c, and high albumin/creatinine ratio.

The Veterans Affairs Diabetes Trial (VADT) randomized 1791 patients with type 2 diabetes to an intensive treatment group and a conventional treatment group (Patel et al. 2008). At the end of the study, there was no significant difference in cardiovascular events between the two treatment arms. As expected, there was an increased incidence of severe hypoglycemia in the intensive treatment group. Predictors for

hypoglycemia included increased duration of diabetes, insulin treatment at baseline, low body mass index (BMI), previous cardiovascular events, and high albumin/creatinine ratio. The ADVANCE study randomized 11,140 participants to an intensive glycemic control arm and a standard glycemic control arm (Duckworth et al. 2009). Although there was an increased risk of hypoglycemia in the intensive treatment arm, there was no association between hypoglycemia and cardiovascular mortality (Duckworth et al. 2009).

It is important to seek out the similarities and differences in the study design and patient population of these studies. Patients in the ADVANCE trial had a 2–3-year shorter duration of diabetes as well as a lower baseline A1c than patients in the ACCORD trial. The number of patients on insulin in the intensive arm versus the standard arm was 77% versus 55% in the ACCORD trial, 90% versus 74% in the VADT trial, and 41% versus 24% in the ADVANCE trial. Thus, the ADVANCE trial had a much smaller proportion of patients on insulin than the ACCORD or VADT trials. This could, in part, account for the low level of hypoglycemia seen in the intensive arm of the ADVANCE trial (<3%) versus the ACCORD trial (16%) and VADT trial (21%).

Hypoglycemia has been also reported in acutely ill patients in whom hyperglycemia is associated with an increased morbidity and mortality (Capes et al. 2000). This has led to a large number of trials using various intensive insulin protocols to control inpatient blood glucose. However, results from these trials have increased the controversy over the risks versus benefit of tight inpatient glycemic control. The Normoglycemia in Intensive Care Evaluation and Surviving Using Glucose Algorithm Regulation (NICE-SUGAR) study found that intensive glucose control increased mortality among adults in the intensive care unit (ICU) (Finfer et al. 2009). The UK Glucose Insulin in Stroke Trial (GIST-UK) looked at tight control of glucose in patients with acute stroke using an intensive insulin infusion protocol and found no benefit (Gray et al. 2007). Though underpowered to draw any firm conclusions, the subanalysis of the mean change in glucose at 24 h showed that patients who had a decrease in plasma glucose of 2 mmol/L or more had a mortality rate of 34% versus 22% for those that had a less than 2 mmol/L decrease (Gray et al. 2007). This raises the question of hypoglycemia having a role in increased mortality in the inpatient setting.

Some recent studies looking at using intensive insulin infusions such as the VISEP showed that the incidence of hypoglycemia was higher in the intensively treated group (Brunkhorst et al. 2008). A study by Kosiborod et al. looking at 16,871 patients admitted with myocardial infarction found that a J-shaped relationship existed between glucose and mortality. Incremental increases above 120 mg/dL and incremental declines below 70 mg/dL were found to be strongly associated with increased mortality (Kosiborod et al. 2008). The slopes of these relationships were even steeper in patients with diabetes, suggesting hypoglycemia could contribute to increased mortality especially in diabetic patients. In another study, a pooled analysis of over 4200 patients from various myocardial infarction intervention studies, death occurred in 4.6% of the patients with hypoglycemia (glucose less than 81 mg/dL) versus 1% of those who were considered euglycemic (81–199 mg/dL) (Pinto et al. 2005). In contrast, a subanalysis of the diabetes mellitus and acute myocardial infarction 2

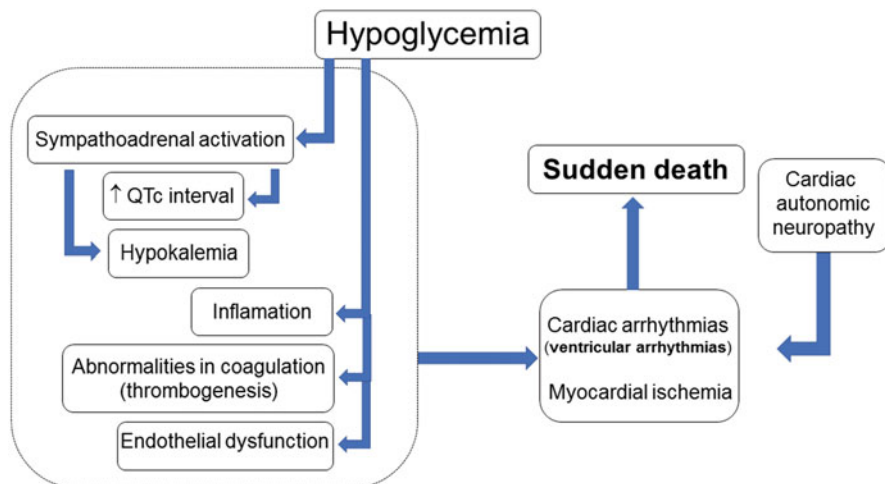

**Fig. 4** The mechanisms by which hypoglycemia may increase cardiovascular risk and mortality

(DIGAMI 2) data did not show hypoglycemia to be an independent risk factor for future morbidity or mortality in patients with type 2 diabetes and myocardial infarction, respectively (Mellbin et al. 2009).

Thus, the role of hypoglycemia in cardiovascular mortality in the inpatient setting is still controversial. However, it is prudent to conclude from the available data that severe hypoglycemia should be avoided as much as possible in the inpatient setting.

Hypoglycemia may increase cardiovascular risk and mortality via several mechanisms (Fig. 4) (Desouza et al. 2010). Hypoglycemia stimulates the release of catecholamines which increase myocardial contractility, myocardial workload, and cardiac output. These effects can induce ischemia in the myocardium in patients with coronary vessel disease (Fisman et al. 2004). The greater oxygen demand is not met because of the rigid vessels but also because of endothelial dysfunction with failure to vasodilate. Several studies have shown that hypoglycemia is associated with a significant lengthening of the corrected QT interval (QTc) in subjects with and without diabetes (Gill et al. 2009; Laitinen et al. 2008). Other electrocardiographic abnormalities observed during hypoglycemia include a decrease in PR interval and moderate ST segment depressions (Laitinen et al. 2008). These changes are likely seen due to increased catecholamine release during hypoglycemia; QTc prolongation in particular could lead to a high risk of ventricular tachycardia and sudden death (Robinson et al. 2003). These changes can be prevented or reversed by beta blockade (Robinson et al. 2003). The increased secretion of catecholamines in response to hypoglycemia may lead to hypokalemia, thus potentiating cardiac repolarization abnormalities. These effects can be reversed by beta blockade and potassium replacement (Robinson et al. 2003).

Autonomic neuropathy is associated with increased mortality. Effects of antecedent hypoglycemia on cardiac autonomic regulation may contribute to the occurrence of adverse cardiac events (Adler et al. 2009). Abnormalities in high-frequency and

low-frequency heart rate variability have been associated with hypoglycemia and increase catecholamine release (Vlcek et al. 2008).

Inflammation has been associated with cardiovascular disease and diabetes. Several inflammatory markers including C-reactive protein (CRP), interleukin 6 (IL-6), interleukin 8 (IL-8), tumor necrosis factor  $\alpha$  (TNF- $\alpha$ ), and endothelin-1 have been shown to be increased during hypoglycemia (Galloway et al. 2000; Razavi Nematollahi et al. 2009). This increase in inflammatory cytokines could result in endothelial injury and abnormalities in coagulation, resulting in increased risk for cardiovascular events.

Hypoglycemia induces abnormalities in platelet function and activation of the fibrinolytic system (Dalsgaard-Nielsen et al. 1982; Fisher et al. 1992). Increased adrenaline levels lead to an increase in platelet activation, leukocyte mobilization, and blood coagulability (Fisher et al. 1992). Many of these changes can be reversed by alpha or beta blockade (Fisher et al. 1992).

Endothelial dysfunction is strongly associated with cardiovascular risk. Recent studies suggest that endothelial function may be compromised during acute hypoglycemia. Vessel wall stiffness was found to be increased during hypoglycemia in patients with type 1 diabetes of longer duration than those with a shorter duration of diabetes (Sommerfield et al. 2007). Thus, hypoglycemia may increase the risk of cardiovascular events especially in a subset of patients with longer duration of diabetes, like in the ACCORD and VADT trials. Inflammation, platelet activation, procoagulant status, and endothelial dysfunction are closely interdependent. These abnormalities could potentially be aggravating factors that contribute to increased cardiovascular risk during severe hypoglycemia especially in patients with pre-existing cardiovascular disease, longer duration of diabetes, and severe autonomic neuropathy, respectively.

---

## The Economic Burden of Hypoglycemia

Hypoglycemia is associated with significant costs and represents a significant economic burden for national healthcare systems. The costs of hypoglycemia include direct, indirect, and intangible costs (Chraibi and Hasna 2016). Costs associated with severe hypoglycemia are higher because of the need for hospitalization and emergency/ambulance care compared to those associated with non-severe hypoglycemia, such as visits to the doctor, glucagon injection, and greater use of extra test strips and lancets. However, because non-severe hypoglycemia is more common than severe hypoglycemia, although generally underreported, the true burden (incidence and cost) of non-severe hypoglycemia may be underestimated (Östenson et al. 2014). Indeed, in economic model-based estimates of non-severe and severe hypoglycemia in people with type 1 and type 2 diabetes in the USA, the economic impact (direct costs) of mild hypoglycemic events was approximately \$900 million per year, roughly equal to that of severe hypoglycemic events (Foos et al. 2015; Samuel et al. 2015). Inpatient hypoglycemia is associated with increased cost mainly owing to the treatment and increased length of stay (Hammer et al. 2009;

Hulkower et al. 2014; Marchesini et al. 2014). A retrospective study in the USA on more than 100,000 hospitalized patients with diabetes demonstrated that patients who developed laboratory evidence of hypoglycemia (blood glucose <70 mg/dL after 24 h) had higher total charges (38.9%), longer lengths of stay (3 days), and higher mortality than diabetic patients without hypoglycemia. Using a lower threshold (<50 mg/dL) to define hypoglycemia resulted in similar findings with a larger magnitude of difference (Curkendall et al. 2009). In some European countries, studies have shown the average treatment cost for a single episode of severe hypoglycemia ranging from €1677 (Barranco et al. 2015) to €1911 (Veronese et al. 2016) with the cost of severe hypoglycemia requiring hospitalization ranged from €1300 to €3300 (Hammer et al. 2009) to €5317 (Veronese et al. 2016). The total cost associated with hypoglycemia in Italy is estimated to be €107 million per year (Giorda et al. 2017). Although comparing the economic cost of hypoglycemia is complex because of differences in healthcare systems, both severe and non-severe hypoglycemia remarkably increase the economic costs for each healthcare system, thus subtracting resources which could be used to improve care for people with diabetes. Needless to say, it is not possible to estimate the burden of hypoglycemia in terms of disruption of quality of life for people with diabetes (Lundkvist et al. 2005).

---

## General Principles of Preventing Hypoglycemia

Given the potential risk of hypoglycemia associated with the use of insulin and/or sulfonylureas and/or glinides, therapeutic regimens should be designed not only to achieve the recommended intensive treatment glycemic targets needed to prevent long-term micro- and macrovascular complications but also to minimize the risk of hypoglycemia. Prevention of severe hypoglycemia is, of course, the primary goal, but prevention of mild/moderate hypoglycemia is similarly important since, as said, it initiates adaptation to hypoglycemia, ultimately leading to a vicious circle of impaired counterregulation → hypoglycemia unawareness → severe hypoglycemia. In order to minimize hypoglycemia during intensive treatment, several considerations need to be taken into account.

First, it is very important that patients are educated about the risk of hypoglycemia. Patient education should include information on hypoglycemia risk and its precipitating factors and on the characteristics of insulin- and glucose-lowering agents as well as training in self-monitoring of glucose control and recognition and self-treatment of hypoglycemia.

Each visit should include a deep evaluation of hypoglycemic episodes to determine their severity and, for those non-severe episodes, to define the clinical presentation (symptomatic vs. asymptomatic), determine the frequency, and understand the contributing factors.

Second, to minimize the risk of hypoglycemia, the glycemic targets for blood glucose control should be tailored to each individual, according to principles of intensive and non-intensive treatment (Bolli et al. 2015) (Table 2). Attention should be given to concomitant morbidities, such as cardiovascular disease, which may



**Table 2** Recommended glycemic targets based on the DCCT and UKPDS trials on intensive treatment to prevent primarily long-term micro- and macroangiopathic complications and limit hypoglycemia in type 1 and type 2 diabetes

<b>Intensive treatment<sup>a</sup></b>	
<b>A1c</b>	<b>&gt;6.5%; &lt;7.0%</b>
Fasting blood glucose	80–130 mg/dL (4.4–7.2 mmol/L)
2-h postprandial blood glucose	<180 mg/dL (<10.0 mmol/L)
<b>Non-intensive treatment<sup>b</sup></b>	
<b>A1c</b>	<b>&gt;7.0%; &lt;8.5%</b>
Fasting blood glucose	120–150 mg/dL (6.7–8.3 mmol/L)
2-h postprandial blood glucose	150–200 mg/dL (8.3–11 mmol/L)

<sup>a</sup>New-onset diabetes, age <75 years, no comorbidities

<sup>b</sup>Long-term diabetes (>30 years), age >75 years, and/or comorbidities

worsen as result of hypoglycemia. This is particularly relevant to patients with diabetes of long duration in whom cardiovascular disease and autonomic neuropathy are likely additional factors that may aggravate the consequences of hypoglycemia.

Third, there are recognized risk factors which may predispose patients to hypoglycemia. Among these the most important are history of severe hypoglycemia, hypoglycemia unawareness, low-glycated HbA1c, low C-peptide levels, and autonomic neuropathy. Therefore, in patients with hypoglycemia risk factors, the glycemic targets of treatment are not euglycemia or A1c <7.0%. Instead blood glucose targets should be set at levels higher than normal, aiming at HbA1c >7.0%, according to non-intensive treatment targets (Bolli et al. 2015). This is also true for frail, older patients or those with complications or short life expectancy.

Under any circumstances, self-monitoring values of plasma glucose (SMPG) <70 mg/dL (<3.9 mmol/L) should be treated to avoid progression to clinical significant hypoglycemia or even to severe hypoglycemia.

## Prevention of Hypoglycemia in Intensively Treated Type 1 Diabetes

The prevention of hypoglycemia during insulin therapy is achieved through a combination of: (1) medical history analysis to determine the frequency and severity of hypoglycemia as well as possible impaired awareness of hypoglycemia, (2) patient education on precipitating causes of hypoglycemia, and (3) implementation of specific therapeutic and behavioral measures to minimize the risk of hypoglycemia.

First and most important is the analysis of a patient's risk factors for iatrogenic hypoglycemia (Table 3). The most significant of these is a history of previous episodes of severe hypoglycemia and impaired awareness of hypoglycemia. These two risk factors alone can increase the risk of severe hypoglycemia by as much as six times.

Precipitating factors of hypoglycemia (Table 4) can largely be addressed by providing proper patient education. Certainly, the well-informed patient is able

**Table 3** Risk factors for severe hypoglycemia in people with diabetes

A history of severe hypoglycemia
Hypoglycemia unawareness
Lower A1c levels, lower glycemic goals
Duration of diabetes
Absolute endogenous insulin deficiency
Diabetic neuropathy
Number of drugs other than antidiabetic agents
Sleep
Exercise
Neoplasms

**Table 4** Precipitating factors for severe hypoglycemia in people with diabetes

Precipitating factors	Mechanism
Excessive insulin or insulin secretagogue dose	↑ Glucose utilization ↓ Glucose production
Reduced carbohydrate intake	↑ Insulin sensitivity
Exercise	↑ Glucose utilization ↑ Insulin sensitivity (after exercise)
Alcohol ingestion	↓ Glucose production ↓ Counterregulation
Night	↑ Insulin sensitivity
Weight reduction	↑ Insulin sensitivity
Improved glycemic control	↑ Insulin sensitivity
Drugs that increase insulin sensitivity	↑ Insulin sensitivity
Injection depth (intramuscular)	↑ Glucose utilization ↓ Glucose production
Site	↑ Insulin sensitivity
Temperature	↑ Insulin sensitivity
Lipohypertrophy	↑ Variability of insulin absorption
Renal failure	↓ Insulin clearance ↓ Glucose production

to better manage both blood glucose control and the prevention of hypoglycemia. The patient should be informed of and know the characteristics of the insulin preparations used, as well as the times of day at greater risk of hypoglycemia; should be educated about the usefulness of self-glycemic control as a guide in choosing an insulin dose; should be able to establish the potential glycemic impact of meals in relation to their carbohydrate content; should be able to properly manage physical exercise; and should be aware of the hypoglycemic effects of alcohol.

Other behavioral measures that the patient needs to know are to control blood glucose in the presence of early symptoms of hypoglycemia, even if only suspected; how to properly correct hypoglycemia with oral, rapidly absorbed, simple carbohydrates, and to always carry sugar packets; to always keep glucagon in the house to be injected intramuscularly; to make family members or friends aware of the

risk of hypoglycemia and train them to be able to inject glucagon or to call an ambulance for hospitalization in the event of the patient's loss of consciousness; to not drive immediately after an episode of hypoglycemia since some aspects of cognition recover fully only after 1–2 h; and to measure blood glucose before driving.

At each visit, it is important to review glucose control with particular attention to hypoglycemic events and their frequency. If hypoglycemia has occurred, it is necessary to understand the temporal relationship between the hypoglycemia event and insulin (prandial vs. basal), the insulin dose, and the carbohydrate content of the preceding meal, whether exercise preceded the event, and whether alcohol or drugs had been ingested. It is important to understand the symptoms of hypoglycemia the patient experienced and whether the patient recognizes those as indicators of incipient hypoglycemia. It is also necessary to rule out that the patient suffers from impaired awareness of hypoglycemia by reviewing blood glucose values and asking if the patient experienced symptoms at hypoglycemic levels. A questionnaire can be used to quantify awareness of hypoglycemia. It must be asked if nocturnal hypoglycemia has occurred. If it has, the frequency must be determined. If it has not, it must be asked if the patient has had symptoms such as night sweats, nightmares, or morning headaches that the patient does not recognize as possibly indicative of nocturnal hypoglycemia. It must always be determined if any episode of hypoglycemia was corrected properly or if episodes of severe hypoglycemia occurred. One thing that healthcare providers should always do is to inspect injection sites at each appointment in order to exclude the presence of areas of lipohypertrophy. Particularly in cases of unexplained hypoglycemia, moving the injection site from a lipohypertrophy to a non-lipohypertrophy area (without lowering the insulin dose) may enhance insulin absorption and increases the risk of hypoglycemia.

To minimize the risk of hypoglycemia in type 1 diabetes, it is important that insulin treatment reproduces as closely as possible the physiology of endogenous insulin secretion in nondiabetic subjects (Rossetti et al. 2008b; Bolli et al. 2015). That goal can be more easily achieved with insulin analogues rather than with conventional human insulins. The currently available insulin analogues, both rapid-acting (lispro, aspart, and glulisine) and long-acting (glargine and detemir), have pharmacokinetic and pharmacodynamic properties that allow achievement of intensive glucose targets with a lower risk of hypoglycemia in comparison with human insulin preparations in the postprandial and fasting state. Thus, human insulin, appropriate for intravenous route, should not be used for subcutaneous delivery, neither at mealtimes (human soluble or regular insulin) nor at night (neutral protamine hagedorn [NPH] insulin has postinjection peak and has high variability of absorption) (Lucidi et al. 2015). The new long-acting insulin analogues degludec and glargine U-300 result in a further reduction in the risk of nocturnal hypoglycemia as compared to glargine U-100 and detemir (Woo 2017) and might represent a good option for people in whom nocturnal hypoglycemia is a significant problem on insulin glargine or detemir. For people who are suffering from impaired awareness of hypoglycemia, frequent episodes of clinically significant hypoglycemia, or severe hypoglycemia, continuous subcutaneous insulin infusion (CSII) might be useful (ADA Standards of Medical Care in Diabetes 2018) and should be proposed. In

addition, when combined with real-time CGM (RT-CGM), it results in reduced time spent in hypoglycemia (<63 mg/dL, 3.5 mmol/L) and a concomitant decrease in HbA1c in children and adults with type 1 diabetes (Battelino et al. 2011; Choudhary et al. 2013). Patients who suffer from HAAF and disabling nocturnal hypoglycemia may benefit from the low-glucose suspend (LGS) function of CSII (Choudhary et al. 2011).

---

## Prevention of Hypoglycemia in Intensively Treated Type 2 Diabetes

The risk of hypoglycemia in type 2 diabetes is secondary to use of insulin and sulfonylureas. Other commonly used antidiabetic agents carry a low risk of hypoglycemia. The early use of insulin is advocated as soon as HbA1c increases consistently above 7.0% despite lifestyle changes and the use of metformin (Nathan et al. 2009). In addition to its efficacy in glucose control, which in the long-term results in the prevention of complications, insulin may also lead to clinical remission of  $\beta$ -cell dysfunction (Weng et al. 2008). Prolonging  $\beta$ -cell function is not only advantageous in terms of glycemic control but is also important in preventing hypoglycemia. If residual insulin secretion is maintained, it is possible for insulin levels to decrease during hypoglycemia, thus protecting against severe hypoglycemia. This also represents a signal for glucagon secretion as a defense against hypoglycemia (Banarer et al. 2002). Insulin should be initiated in a single daily administration of a basal preparation to reduce fasting hyperglycemia (Nathan et al. 2009), the primary contributor to elevated HbA1c, when the HbA1c value is above 8.0% (Monnier et al. 2003). NPH insulin has been proven to be as effective as glargine or detemir in reducing HbA1c to 7.0%, but it results in a higher risk of nocturnal hypoglycemia (Riddle et al. 2003; Hermansen et al. 2006), and for this reason, long-acting insulin analogues, not NPH, should be used as basal insulin in type 2 diabetes. The potential risks of hypoglycemia associated with early use of insulin are minimized by opting for long-acting insulin analogues. In subjects on basal insulin, fasting blood glucose is at target (close to 100 mg/dL; 5.5 mmol/L), but HbA1c remains above 7.0% because of relevant postprandial hyperglycemia. Under these circumstances, a rapid-acting insulin analogue should be added whenever a carbohydrate-rich meal is eaten (Owens et al. 2001). More recently, an attractive alternative has been proposed, i.e., the addition of glucagon-like peptide 1 receptor agonists (GLP-1RAs) to basal insulin, which reduces postprandial hyperglycemia and at the same time, reduces the risk of hypoglycemia and body weight (Porcellati et al. 2015; Wysham et al. 2017). The combination of insulin and sulfonylureas, although presented in the general recommendations of potential sequences of anti-hyperglycemic therapy for patients with type 2 diabetes (ADA Standards of Medical Care in Diabetes 2018), should be avoided because it has the highest risk of hypoglycemia. It should be noted that sulfonylurea-induced hypoglycemia can be long-lasting and life-threatening. The risk associated with the use of glibenclamide (glyburide) for severe hypoglycemia is higher than that of using other types of sulfonylureas (Shorr et al. 1996). The reason glibenclamide carries a greater risk

**Table 5** Essential factors necessary to prevent hypoglycemia in diabetes

---

Consider the risk of hypoglycemia, including at night, for each individual patient, then use the safest treatment and glycemic targets (individualize the goals)
Maintain frequent contacts between the diabetes team and patient
Practice frequent blood glucose monitoring
Measure blood glucose at night (especially in patients with hypoglycemia unawareness)
Prevent hypoglycemia (treat glucose values <70 mg/dL; 3.9 mmol/L)
When present, reverse hypoglycemia unawareness
If necessary, use technological support to detect and correct hypoglycemia
Provide structured education about prevention and treatment of hypoglycemia

---

of hypoglycemia than other sulfonylureas is not fully established. However, although it does not alter glucagon and other counterregulatory responses to hypoglycemia, glibenclamide, more than glimepiride, inappropriately stimulates insulin secretion during recovery from hypoglycemia despite low plasma glucose levels (Szoke et al. 2006). Based on these considerations, glucose-lowering agents that do not cause hypoglycemia should be used in the place of sulfonylureas (Monami et al. 2014); but, if sulfonylureas are used, agents different from glibenclamide should be preferred (Nathan et al. 2009). In contrast with sulfonylureas, the use of glucose-sensitizing agents such as metformin, glucagon-like peptide-1 agonists, dipeptidyl peptidase-4 inhibitors, pioglitazone, and SGLT2 inhibitors is particularly advantageous in preventing hypoglycemia in type 2 diabetes. In addition to increasing the risk of hypoglycemia, sulfonylurea therapy might increase the risk of cardiovascular-related events compared with other antihyperglycemic drugs (Bain et al. 2017). Table 5 summarizes an overall approach to prevent hypoglycemia in diabetes.

---

## Treatment of Hypoglycemia Unawareness

It should be kept in mind that frequently recurring hypoglycemia, even when mild, causes impaired awareness of hypoglycemia and defective glucose counterregulation (HAAF), ultimately leading to a greater risk of severe hypoglycemia. When such complications occur, the institution of a program of meticulous avoidance of hypoglycemia, which initially can be based on raising the target for fasting, premeal, and nocturnal blood glucose by 20–40 mg/dL (1.2–2.2 mmol/L) over a short period of time, usually 2–3 weeks, restores almost normal awareness and may improve the defensive hormonal response to hypoglycemia in the majority of subjects (Fanelli et al. 1993a; Dagogo-Jack et al. 1994; Cranston et al. 1994). For some people, the results can be maintained in the long term (Dagogo-Jack et al. 1999). This approach has entered standard clinical practice as an effective way to reverse hypoglycemia unawareness and reduce the risk of future episodes (ADA Standards of Medical Care in Diabetes 2008). Among other strategies for treatment of impaired awareness of hypoglycemia, blood glucose awareness training (BGAT), a psychoeducational programmatic intervention, designed to improve the accuracy

of patients' detection and interpretation of relevant blood glucose symptoms and to point out other cues to help them avoid severe hypoglycemia, has proven to be valuable in improving awareness (Cox et al. 1995). BGAT has shown to have long-term benefits and may result in reduction of severe hypoglycemic episodes and automobile crashes in the long term (Cox et al. 1994). The Dose Adjustment for Normal Eating (DAFNE), a program of intensive insulin therapy for type 1 diabetes which provides a structured educational intervention, has been shown to improve glycemic control, quality of life, and hypoglycemia awareness and to reduce the frequency of hypoglycemia (from  $1.7 \pm 8.5$  to  $0.6 \pm 3.7$  episodes per person per year) (Hopkins et al. 2012). Preliminary data are encouraging from a new psychoeducational program, DAFNE-HART, that incorporates psychological intervention into diabetes education and has been recently specifically designed to address impaired awareness of hypoglycemia persisting despite otherwise optimized insulin self-management (de Zoysa et al. 2014). Therefore, it appears that a structured education program incorporating psychological interventions is a valuable therapeutic tool to prolong hypoglycemia awareness in people with problematic hypoglycemia. Technological-based approaches, such as real-time continuous glucose monitoring (RT-CGM), may have the potential of restoring adrenaline response to hypoglycemia in people with type 1 diabetes with hypoglycemia unawareness (Ly et al. 2011). For selected patients, CSII and the use of RT-CGM may be the best approach. However, in one study comparing the treatment with multiple daily dose insulin (MDI) versus CSII and SMBG versus RT-CGM at 24 weeks, in people with long-standing disease who received comparable education, attention, support, and similar therapeutic targets aimed at rigorous avoidance of biochemical hypoglycemia without relaxing overall control, hypoglycemia awareness improved similarly with no significant differences in reduction of severe hypoglycemic episodes (Little et al. 2014). This study shows the importance of not only a standardized education about avoidance of hypoglycemia but also of advice on self-adjustment of insulin doses according to carbohydrate intake; SMBG including a 4 a.m. weekly check, telephone contacts, and planned activity; and recommendation for oral carbohydrate administration for all glucose levels  $<4.0$  mmol/L.

A recent systematic review and meta-analysis evaluating the educational, technological, and pharmacological interventions aimed at restoring hypoglycemia awareness in adults with type 1 diabetes provided evidence for the effectiveness of a stepped-care approach in the management of patients with impaired awareness of hypoglycemia, initiating with structured diabetes education in flexible insulin therapy, which may incorporate psychotherapeutic and behavioral therapies, progressing to diabetes technology, incorporating sensors and insulin pumps, in those with persisting needs (Yeoh et al. 2015). Technological interventions (insulin pump therapy, CGM, and sensor augmented pump [SAP] including the low suspend function and the more advanced predictive low glucose insulin suspension [PLGS] function) (Ly et al. 2013; Choudhary et al. 2016; Battelino et al. 2017) reduce severe hypoglycemia when used in combination with structured education and frequent contact. Additional information on the approach to restore recognition of hypoglycemia in patients with HAAF has been recently reviewed (Seaquist et al. 2013).

---

## Treatment of Hypoglycemia

The treatment of hypoglycemia, in people who are able to swallow, follows the well-known “rule of 15,” which consists in giving 15 g of rapidly absorbed carbohydrate, such as 150–200 mL of pure fruit juice or soda or sugar dissolved in water. Capillary glucose measurements should be repeated 15 min after ingestion and treatment repeated, up to three times at 15 min intervals if needed, until the glucose is  $>70$  mg/dL (4.0 mmol/L). For people who are unable to swallow or unconscious, oral glucose must be avoided due to the risk of aspirating. Instead, intramuscular injection of glucagon (1 mg in adults and 0.5 mg in children) should be given by a relative or friend who is aware of the hypoglycemia risk of the subject and prepared to the treatment. Following recovery of consciousness, complex carbohydrate should be ingested. Alternative to glucagon and in cases of severe hypoglycemia (coma and seizures), intravenous glucose 16–20 g (80–100 mL of 20% glucose) can be given over 10–15 min and repeated up to recovery consciousness, eventually followed by a continuous infusion at the rate of 60–80 mL/h until glucose is stable and the patient is able to eat.

---

## Conclusions

Hypoglycemia continues to be the rate-limiting step of intensive treatment of diabetes with insulin and sulfonylureas. Research over the last decades has enormously expanded the knowledge about causes, risks, and consequences of hypoglycemia. Many advances have been made since the DCCT including availability of rapid-acting and long-acting insulin analogues, which reduce the risk of hypoglycemia associated with use of human insulin. More recently, the relevant progresses in the quality of CGM allow patients to monitor themselves closely avoiding hypoglycemia. However, education of patients to prevent, recognize, and promptly treat hypoglycemia appropriately remains a key factor for the long-term risk reduction of hypoglycemia. Considering that hypoglycemia is the limiting factor in achieving optimal glycemic target, the selection of glycemic targets in each patient should be individualized to the lowest HbA1c level that does not cause severe hypoglycemia, that preserves hypoglycemia awareness, and that avoids long-term micro- and macrovascular complications and maintains good quality of life.

---

## References

- Abraira C, Henderson W, Colwell J, VA CSDM Group, et al. Response to intensive therapy steps and to glipizide dose in combination with insulin in type 2 diabetes (VA feasibility study). *Diabetes Care*. 1998;21:574–9.
- ADA. Standards of medical care in diabetes – 2008. *Diabetes Care*. 2008;31(Suppl 1):S12–54.
- Adler GK, Bonyhay I, Failing H, Waring E, Dotson S, Freeman R. Antecedent hypoglycemia impairs autonomic cardiovascular function: implications for rigorous glycemic control. *Diabetes*. 2009;58:360–6.

- American Diabetes Association. Standards of medical care in diabetes 2018. *Diabetes Care*. 2018;41(Suppl 1):S55–64.
- Arbelaez AM, Xing D, Cryer PE, Kollman C, Beck RW, Sherr J, Ruedy KJ, Tamborlane WV, Mauras N, Tsalikian E, Wilson DM, White NH, Diabetes Research in Children Network (DirecNet) Study Group. Blunted glucagon but not epinephrine responses to hypoglycemia occurs in youth with less than 1 yr duration of type 1 diabetes mellitus. *Pediatr Diabetes*. 2014;15:127–34.
- Bain S, Druyts E, Balijepalli C, Baxter CA, Currie CJ, Das R, Donnelly R, Khunti K, Langerman H, Leigh P, Siliman G, Thorlund K, Toor K, Vora J, Mills EJ. Cardiovascular events and all-cause mortality associated with sulfonylureas compared with other antihyperglycaemic drugs: a Bayesian meta-analysis of survival data. *Diabetes Obes Metab*. 2017;19:329–35.
- Banarer S, Cryer PE. Sleep-related hypoglycemia-associated autonomic failure in type 1 diabetes: reduced awakening from sleep during hypoglycemia. *Diabetes*. 2003;52:1195–203.
- Banarer S, McGregor VP, Cryer PE. Intrailelet hyperinsulinemia prevents the glucagon response to hypoglycemia despite an intact autonomic response. *Diabetes*. 2002;51:958–65.
- Barranco RJ, Gomez-Peralta F, Abreu C, Delgado M, Palomares R, et al. Incidence and care-related costs of severe hypoglycemia requiring emergency treatment in Andalusia (Spain): the PAUEPAD project. *Diabet Med*. 2015;32:1520–6.
- Battelino T, Phillip M, Bratina N, Nimri R, Oskarsson P, Bolinder J. Effect of continuous glucose monitoring on hypoglycemia in type 1 diabetes. *Diabetes Care*. 2011;34:795–800.
- Battelino T, Nimri R, Dovc K, Phillip M, Bratina N. Prevention of hypoglycemia with predictive low glucose insulin suspension in children with type 1 diabetes: a randomized controlled trial. *Diabetes Care*. 2017;40:764–770.
- Beall C, Hamilton DL, Gallagher J, Logie L, Wright K, Soutar MP, Dadak S, Ashford FB, Haythorne E, Du Q, Jovanović A, McCrimmon RJ, Ashford ML. Mouse hypothalamic GT1-7 cells demonstrate AMPK-dependent intrinsic glucose-sensing behaviour. *Diabetologia*. 2012;55:2432–44.
- Bolli GB. From physiology of glucose counterregulation to prevention of hypoglycemia in type 1 diabetes mellitus. *Diabetes Nutr Metab*. 1990;4:333–49.
- Bolli GB, Fanelli CG. Physiology of glucose counterregulation to hypoglycemia. *Endocrinol Metab Clin N Am*. 1999;28:467–93.
- Bolli GB, De Feo P, De Cosmo S, Perriello G, Ventura MM, Benedetti MM, Santeusano F, Gerich JE, Brunetti P. A reliable and reproducible test for adequate glucose counterregulation in type I diabetes mellitus. *Diabetes*. 1984a;33:732–7.
- Bolli GB, Dimitriadis GD, Pehling GB, Baker BA, Haymond MW, Cryer PE, Gerich JE. Abnormal glucose counterregulation after subcutaneous insulin in insulin-dependent diabetes mellitus. *N Engl J Med*. 1984b;310:1706–11.
- Bolli GB, Porcellati F, Lucidi P, Fanelli CG. Glucose control in diabetes: targets and therapy. In: Bruttomesso D, Grassi G (eds): *Technological advances in the treatment of type 1 diabetes*. Front Diabetes. Basel, Karger, 2015, vol 24, pp 1–10.
- Borg MA, Sherwin RS, Borg WP, Tamborlane WV, Shulman GI. Local ventromedial hypothalamus glucose perfusion blocks counterregulation during systemic hypoglycemia in awake rats. *J Clin Invest*. 1997;99:361–5.
- Boyle PJ, Schwartz NS, Shah SD, Clutter WE, Cryer PE. Plasma glucose concentrations at the onset of hypoglycemic symptoms in patients with poorly controlled diabetes and in nondiabetics. *N Engl J Med*. 1988;318:1487–92.
- Boyle PJ, Kempers SF, O'Connor AM, Nagy RJ. Brain glucose uptake and unawareness of hypoglycemia in patients with insulin dependent diabetes mellitus. *N Engl J Med*. 1995;333:1726–31.
- Bramlage P, Gitt AK, Binz C, Krekler M, Deeg E, Tschöpe D. Oral antidiabetic treatment in type-2 diabetes in the elderly: balancing the need for glucose control and the risk of hypoglycemia. *Cardiovasc Diabetol*. 2012;11:122.



- Bremer JP, Jauch-Chara K, Hallschmid M, Schmid S, Schultes B. Hypoglycemia unawareness in older compared with middle-aged patients with type 2 diabetes. *Diabetes Care*. 2009;32:1513–7.
- Brunkhorst FM, Engel C, Bloos F, Meier-Hellmann A, Ragaller M, Weiler N, Moerer O, Gruendling M, Oppert M, Grond S, Olthoff D, Jaschinski U, John S, Rossaint R, Welte T, Schaefer M, Kern P, Kuhnt E, Kiehntopf M, Hartog C, Natanson C, Loeffler M, Reinhart K. Intensive insulin therapy and pentastarch resuscitation in severe sepsis. *N Engl J Med*. 2008;358:125–39.
- Cahill GF Jr, Herrera MG, Morgan AP, et al. Hormone-fuel interrelationship during fasting. *J Clin Invest*. 1966;45:1751–69.
- Cahill GF Jr. Starvation in man. *N Engl J Med*. 1970;282:668–75.
- Capes SE, Hunt D, Malmberg K, Gerstein HC. Stress hyperglycaemia and increased risk of death after myocardial infarction in patients with and without diabetes: a systematic overview. *Lancet*. 2000;355:773–8.
- Cersosimo E, Judd RL, Miles JM. Insulin regulation of renal glucose metabolism in conscious dogs. *J Clin Invest*. 1994;93:2584–9.
- Cersosimo E, Molina PE, Abumrad NN. Renal glucose production during insulin-induced hypoglycemia. *Diabetes*. 1997;46:643–6.
- Cersosimo E, Garlick P, Ferretti J. Insulin regulation of renal glucose metabolism in humans. *Am J Phys*. 1999a;276:E78–84.
- Cersosimo E, Garlick P, Ferretti J. Renal glucose production during insulin-induced hypoglycemia in humans. *Diabetes*. 1999b;48:261–6.
- Chan O, Sherwin R. Influence of VMH fuel sensing on hypoglycemic responses. *Trends Endocrinol Metab*. 2013;24:616–24.
- Choi IY, Gruetter R. In vivo <sup>13</sup>C NMR assessment of brain glycogen concentration and turnover in the awake rat. *Neurochemistry International*. 2003;43(4–5):317–322.
- Choudhary P, Shin J, Wang Y, Evans ML, Hammond PJ, Kerr D, Shaw JA, Pickup JC, Amiel SA. Insulin pump therapy with automated insulin suspension in response to hypoglycemia: reduction in nocturnal hypoglycemia in those at greatest risk. *Diabetes Care*. 2011;34:2023–5.
- Choudhary P, Ramasamy S, Green L, Gallen G, Pender S, Brackenridge A, Amiel SA, Pickup JC. Realtime continuous glucose monitoring significantly reduces severe hypoglycemia in hypoglycemia unaware patients with type 1 diabetes. *Diabetes Care*. 2013;36:4160–2.
- Choudhary P, Olsen BS, Conget I, Welsh JB, Vorrink L, Shin JJ. Hypoglycemia prevention and user acceptance of an insulin pump system with predictive low glucose management. *Diabetes Technol Ther*. 2016;18:288–291.
- Chraïbi A, Hasna A. The cost of hypoglycemia. In: *Hypoglycemia-causes and occurrences*. 2016. ISBN: 978-1-944685-80-5, 1-4. Downloadable at: <http://www.smgebooks.com/hypoglycemia-causes-occurrences/chapters/HG-16-02.pdf>
- Clarke DD, Sokoloff L. Circulation and energy metabolism of the brain. In: Siegel GJ, et al., editors. *Basic neurochemistry: molecular, cellular and medical aspects*. 5th ed. New York: Raven Press; 1994. p. 645–52.
- Coiro V, Volpi R, Cataldo S, Magotti MG, Giumelli C, Russo F, Stella A, Chiodera P. Glucoreceptors located in the brain mediate NPY release induced by hypoglycemia in normal men. *Regul Pept*. 2011;172:41–3.
- Cox DJ, Gonder-Frederick L, Julian DM, Clarke W. Long-term follow-up evaluation of blood glucose awareness training. *Diabetes Care*. 1994;17:1–5.
- Cox D, Gonder-Frederick L, Polonsky W, Schlundt D, Julian D, Clarke W. A multicenter evaluation of blood glucose awareness training-II. *Diabetes Care*. 1995;18:523–8.
- Cranston I, Lomas J, Maran A, Macdonald I, Amiel SA. Restoration of hypoglycemia awareness in patients with long-duration insulin-dependent diabetes. *Lancet*. 1994;344:283–7.
- Cryer PE. Iatrogenic hypoglycemia as a cause of hypoglycemia-associated autonomic failure in IDDM. A vicious cycle. *Diabetes*. 1992;41:255–60.

- Cryer PE. Hypoglycemia-associated autonomic failure in diabetes. *Am J Phys.* 2001;281:E1115–21.
- Cryer PE. Diverse causes of hypoglycemia-associated autonomic failure in diabetes. *N Engl J Med.* 2004;350:2272–9.
- Cryer PE. Mechanisms of hypoglycemia-associated autonomic failure and its component syndromes in diabetes. *Diabetes.* 2005;54:3592–601.
- Cryer PE. Exercise-related hypoglycemia-associated autonomic failure in diabetes. *Diabetes.* 2009;58:1951–2.
- Cryer PE. Mechanisms of hypoglycemia-associated autonomic failure in diabetes. *N Engl J Med.* 2013;369:362–72.
- Cryer PE. Hypoglycemia in diabetes: pathophysiology, prevalence, and prevention. 3rd ed. Alexandria: American Diabetes Association; 2016. p. 3–8.
- Cryer PE, Davis SN, Shamoon HS. Hypoglycemia in diabetes. *Diabetes Care.* 2003;26:1902–12.
- Curkendall SM, Natoli JL, Alexander CM, Nathanson BH, Haidar T, et al. Economic and clinical impact of inpatient diabetic hypoglycemia. *Endocr Pract.* 2009;15:302–12.
- Dagogo-Jack S, Philip E, Cryer, MD: seminal contributions to the understanding of hypoglycemia and glucose counterregulation and the discovery of HAAF (Cryer syndrome). *Diabetes Care.* 2015;38:2193–9.
- Dagogo-Jack SE, Cryer PE. Hypoglycemia-associated autonomic failure in insulin-dependent diabetes mellitus. Recent antecedent hypoglycemia reduces autonomic responses to, symptoms of, and defense against subsequent hypoglycemia. *J Clin Invest.* 1993;91:819–8.
- Dagogo-Jack S, Rattarasam C, Cryer PE. Reversal of hypoglycemia unawareness, but not defective glucose counterregulation, in IDDM. *Diabetes.* 1994;43:1426–34.
- Dagogo-Jack S, Fanelli CG, Cryer PE. Durable reversal of hypoglycemia unawareness in type 1 diabetes. *Diabetes Care.* 1999;22:866–7.
- Dalsgaard-Nielsen J, Madsbad S, Hilsted J. Changes in platelet function, blood coagulation and fibrinolysis during insulin-induced hypoglycemia in juvenile diabetics and normal subjects. *Thromb Haemost.* 1982;47:254–8.
- DCCT Research Group. Epidemiology of severe hypoglycemia in the diabetes control and complications trial. The DCCT Research Group. *Am J Med.* 1991;90:450–9.
- De Feo P, Perriello G, De Cosmo S, et al. Comparison of glucose counterregulation during short-term and prolonged hypoglycemia in normal humans. *Diabetes.* 1986;35:563–9.
- de Galan BE, Zoungas S, Chalmers J, Anderson C, Dufouil C, Pillai A, Cooper M, Grobbee DE, Hackett M, Hamet P, Heller SR, Lisheng L, Macmahon S, Mancia G, Neal B, Pan CY, Patel A, Poulter N, Travert F, Woodward M, ADVANCE Collaborative Group. Cognitive function and risks of cardiovascular disease and hypoglycemia in patients with type 2 diabetes: the action in diabetes and vascular disease: Preterax and Diamicon Modified Release Controlled Evaluation (ADVANCE) trial. *Diabetologia.* 2009;52:2328–36.
- de Zoysa N, Rogers H, Stadler M, Gianfrancesco C, Beveridge S, Britneff E, Choudhary P, Elliott J, Heller S, Amiel SA. A psychoeducational program to restore hypoglycemia awareness: the DAFNE-HART pilot study. *Diabetes Care.* 2014;37:863–6.
- DeRosa MA, Cryer PE. Hypoglycemia and the sympathoadrenal system: neurogenic symptoms are largely the result of sympathetic neural, rather than adrenomedullary, activation. *Am J Physiol Endocrinol Metab.* 2004;287:E32–41.
- Desouza C, Salazar H, Cheong B, Murgo J, Fonseca V. Association of hypoglycemia and cardiac ischemia: a study based on continuous monitoring. *Diabetes Care.* 2003;26:1485–9.
- Desouza CV, Bolli GB, Fonseca V. Hypoglycemia, diabetes, and cardiovascular events. *Diabetes Care.* 2010;33:1389–94.
- Di Rocco R, Grill H. The forebrain is not essential for sympathoadrenal hyperglycemic response to glucoprivation. *Science.* 1979;204:1112–4.
- Diabetes Control and Complications Trial/Epidemiology of Diabetes Interventions and Complications Study Research Group, Jacobson AM, Musen G, Ryan CM, Silvers N, Cleary P,

- Waberski B, Burwood A, Weinger K, Bayless M, Dahms W, Harth J. Long-term effect of diabetes and its treatment on cognitive function. *N Engl J Med.* 2007;356:1842–52.
- Donovan CM, Watts AG. Peripheral and central glucose sensing in hypoglycemic detection. *Physiology (Bethesda).* 2014;29:314–24.
- Duckworth W, Abraira C, Moritz T, Reda D, Emanuele N, Reaven PD, Zieve FJ, Marks J, Davis SN, Hayward R, Warren SR, Goldman S, McCarren M, Vitek ME, Henderson WG, Huang GD. Glucose control and vascular complications in veterans with type 2 diabetes. *N Engl J Med.* 2009;360:129–39.
- Egeli ES, Berkmen R. Action of hypoglycemia on coronary insufficiency and mechanism of ECG alterations. *Am Heart J.* 1960;59:527–40.
- EMA. Guideline on clinical investigation of medicinal products in the treatment or prevention of diabetes mellitus. European Medicine Agency. 2012. Accessed 1 Feb 2017.
- Evans ML, McCrimmon RJ, Flanagan DE, Keshavarz T, Fan X, McNay EC, Jacob RJ, Sherwin RS. Hypothalamic ATP-sensitive K<sup>+</sup> channels play a key role in sensing hypoglycemia and triggering counterregulatory epinephrine and glucagon responses. *Diabetes.* 2004;53:2542–51.
- Fanelli C, Epifano L, Rambotti A, Pampanelli S, Di Vincenzo A, Modarelli F, Lepore M, Ciofetta M, Bottini P, Porcellati F, Scionti L, Santeusano F, Brunetti P, Bolli GB. Meticulous prevention of hypoglycemia normalizes the glycemic thresholds and magnitude of most of neuroendocrine responses to, symptoms of, and cognitive function during hypoglycemia in intensively treated patients with short-term IDDM. *Diabetes.* 1993a;42:1683–9.
- Fanelli C, Calderone S, Epifano L, De Vincenzo A, Modarelli F, Pampanelli S, Perriello G, De Feo P, Brunetti P, Gerich JE, Bolli GB. Demonstration of a critical role for free fatty acids in mediating counterregulatory stimulation of gluconeogenesis and suppression of glucose utilization in humans. *J Clin Invest.* 1993b;92:1617–22.
- Fanelli C, Pampanelli S, Epifano L, Rambotti AM, Di Vincenzo A, Modarelli F, Ciofetta M, Lepore M, Annibale B, Torlone E, Perriello G, De Feo P, Santeusano F, Brunetti P, Bolli GB. Long-term recovery from unawareness, deficient counterregulation and lack of cognitive dysfunction during hypoglycemia, following institution of rational, intensive insulin therapy in IDDM. *Diabetologia.* 1994a;37:1265–76.
- Fanelli C, Pampanelli S, Epifano L, Rambotti AM, Ciofetta M, Modarelli F, Di Vincenzo A, Annibale B, Lepore M, Lalli C, Del Sindaco P, Brunetti P, Bolli GB. Relative roles of insulin and hypoglycemia on induction of neuroendocrine responses to, symptoms of, and deterioration of cognitive function in hypoglycemia in male and female humans. *Diabetologia.* 1994b;37:797–807.
- Fanelli C, Pampanelli S, Lalli C, Del Sindaco P, Ciofetta M, Lepore M, Porcellati F, Bottini P, Di Vincenzo A, Brunetti P, Bolli GB. Long-term intensive therapy of IDDM diabetic patients with clinically overt autonomic neuropathy: effects on awareness of, and counterregulation to hypoglycemia. *Diabetes.* 1997;46:1172–81.
- Fanelli CG, Paramore DS, Hershey T, et al. Impact of nocturnal hypoglycemia on hypoglycemic cognitive dysfunction in type 1 diabetes. *Diabetes.* 1998;47:1920–7.
- Fanelli CG, Pampanelli S, Porcellati F. Cognitive function in hypoglycemia. *Diabetes Nutr Metab.* 2002;15:367–72.
- FDA Guidance for industry Diabetes Mellitus: developing drugs and therapeutic biologics for treatment and prevention. 2008. <http://www.fda.gov/downloads/Drugs/Guidances/ucm071624.pdf>. Accessed 1 Feb 2017.
- Finfer S, Chittock DR, Su SY, Blair D, Foster D, Dhingra V, Bellomo R, Cook D, Dodek P, Henderson WR, Hebert PC, Heritier S, Heyland DK, McArthur C, McDonald E, Mitchell I, Myburgh JA, Norton R, Potter J, Robinson BG, Ronco JJ. Intensive versus conventional glucose control in critically ill patients. *N Engl J Med.* 2009;360:1283–97.
- Fisher BM, Hepburn DA, Smith JG, Frier BM. Responses of peripheral blood cells to acute insulin-induced hypoglycemia in humans: effect of alpha-adrenergic blockade. *Horm Metab Res Suppl.* 1992;26:109–10.

- Fisman EZ, Motro M, Tenenbaum A, Leor J, Boyko V, Mandelzweig L, Sherer Y, Adler Y, Behar S. Is hypoglycemia a marker for increased long-term mortality risk in patients with coronary artery disease? An 8-year follow-up. *Eur J Cardiovasc Prev Rehabil.* 2004;11:135–43.
- Foos V, Varol N, Curtis BH, Boye KS, Grant D, Palmer JL, McEwan P. Economic impact of severe and non-severe hypoglycemia in patients with type 1 and type 2 diabetes in the United States. *J Med Econ.* 2015;18:420–32.
- Frier BM. The economic costs of hypoglycemia. *Br J Diabetes Vasc Dis.* 2011;11(Suppl 1): S10–2.
- Fritsche A, Stefan N, Häring H, Gerich J, Stumvoll M. Avoidance of hypoglycemia restores hypoglycemia awareness by increasing beta-adrenergic sensitivity in type 1 diabetes. *Ann Intern Med.* 2001;134:729–36.
- Frohman L, Nagai K. Central nervous system-mediated stimulation of glucagon secretion in the dog following 2-deoxyglucose. *Metabolism.* 1976;25:1449–52.
- Fruehwald-Schultes B, Born J, Kern W, Peters A, Fehm HL. Adaptation of cognitive function to hypoglycemia in healthy men. *Diabetes Care.* 2000;23:1059–66.
- Frye RL, August P, Brooks MM, Hardison RM, Kelsey SF, MacGregor JM, Orchard TJ, Chaitman BR, Genuth SM, Goldberg SH, Hlatky MA, Jones TL, Molitch ME, Nesto RW, Sako EY, Sobel BE. A randomized trial of therapies for type 2 diabetes and coronary artery disease. *N Engl J Med.* 2009;360:2503–15.
- Galloway PJ, Thomson GA, Fisher BM, Semple CG. Insulin-induced hypoglycemia induces a rise in C-reactive protein. *Diabetes Care.* 2000;23:861–2.
- Geddes J, Schopman JE, Zammitt NN, Frier BM. Prevalence of impaired awareness of hypoglycemia in adults with type 1 diabetes. *Diabet Med.* 2008;25:501–4.
- Gerich J. Hypoglycemia and counterregulation in type 2 diabetes. *Lancet.* 2000;356:1946–7.
- Gerich JE. Hepatorenal glucose reciprocity in physiologic and pathologic conditions. *Diabetes Nutr Metab.* 2003;15:298–303.
- Gerich JE, Mokan M, Veneman T, Korytkowski M, Mitrakou A. Hypoglycemia unawareness. *Endocr Rev.* 1991;12:356–71.
- Gerstein HC, Miller ME, Byington RP, Goff DC Jr, Bigger JT, Buse JB, Cushman WC, Genuth S, Ismail-Beigi F, Grimm RH Jr, Probstfield JL, Simons-Morton DG, Friedewald WT. Effects of intensive glucose lowering in type 2 diabetes. *N Engl J Med.* 2008;358:2545–59.
- Gill GV, Woodward A, Casson IF, Weston PJ. Cardiac arrhythmia and nocturnal hypoglycemia in type 1 diabetes – the ‘dead in bed’ syndrome revisited. *Diabetologia.* 2009;52:42–5.
- Giorda CB, Ozzello A, Gentile S, Corsi A, Iannarelli R, Baccetti F, Lucisano G, Nicolucci A, Rossi MC. On behalf the HYPOS-1 study group incidence and correlates of hypoglycemia in type 2 diabetes. The Hypos-1 study. *J Diabetes Metab.* 2014;3:2–8.
- Giorda CB, Ozzello A, Gentile S, Agliatoro A, Chiambretti A, Baccetti F, Gentile FM, Lucisano G, Nicolucci A, Rossi MC, HYPOS-1 Study Group of AMD. Incidence and risk factors for severe and symptomatic hypoglycemia in type 1 diabetes. Results of the HYPOS-1 study. *Acta Diabetol.* 2015;52:845–53.
- Giorda CB, Rossi MC, Ozzello O, Gentile S, Agliatoro A, Chiambretti A, Baccetti F, Gentile FM, Romeo F, Lucisano G, Nicolucci A, HYPOS-1 Study Group of AMD. Healthcare resource use, direct and indirect costs of hypoglycemia in type 1 and type 2 diabetes, and nationwide projections. Results of the HYPOS-1 study. *Nutr Metab Cardiovasc Dis.* 2017;27:209–16.
- Gold AE, MacLeod KM, Frier BM. Frequency of severe hypoglycemia in patients with type 1 diabetes with impaired awareness of hypoglycemia. *Diabetes Care.* 1994;17:697–703.
- Gray CS, Hildreth AJ, Sandercock PA, O’Connell JE, Johnston DE, Cartledge NE, Bamford JM, James OF, Alberti KG. Glucose-potassium-insulin infusions in the management of post-stroke hyperglycaemia: the UK Glucose Insulin in Stroke Trial (GIST-UK). *Lancet Neurol.* 2007;6:397–406.
- Green AJ, Fox KM, Grandy S, SHIELD Study Group. Self-reported hypoglycemia and impact on quality of life and depression among adults with type 2 diabetes mellitus. *Diabetes Res Clin Pract.* 2012;96:313–8.

- Gruetter R, Ugurbil K, Seaquist ER. Steady-state cerebral glucose concentrations and transport in the human brain. *J Neurochem.* 1998;70:397–408.
- Hammer M, Lammert M, Mejías SM, Kern W, Frier BM. Costs of managing severe hypoglycemia in three European countries. *J Med Econ.* 2009;12:281–90.
- Heller S, Cryer PE. Reduced neuroendocrine and symptomatic responses to subsequent hypoglycemia after one episodes of hypoglycemia in nondiabetic humans. *Diabetes.* 1991;40:223–6.
- Henderson JN, Allen KV, Deary IJ, Frier BM. Hypoglycemia in insulin-treated type 2 diabetes: frequency, symptoms and impaired awareness. *Diabet Med.* 2003;20:1016–21.
- Hepburn DA, MacLeod KM, Pell ACH, Scougal IJ, Frier BM. Frequency and symptoms of hypoglycemia experienced by patients with type 2 diabetes treated with insulin. *Diabet Med.* 1993;10:231–7.
- Hermansen K, Davies M, Derezinski T, Martinez Ravn G, Clauson P, Home P. A 26-week, randomized, parallel, treat-to-target trial comparing insulin detemir with NPH insulin as add-on therapy to oral glucose lowering drugs in insulin-naive people with type 2 diabetes. *Diabetes Care.* 2006;29:1269–74.
- Hershey T, Perantie DC, Warren SL, Zimmerman EC, Sadler M, White NH. Frequency and timing of severe hypoglycemia affects spatial memory in children with type 1 diabetes. *Diabetes Care.* 2005;28:2372–7.
- Hewitt J, Smeeth L, Chaturvedi N, Bulpitt CJ, Fletcher AE. Self management and patient understanding of diabetes in the older person. *Diabet Med.* 2011;28:117–22.
- Hopkins D, Lawrence I, Mansell P, Thompson G, Amiel S, Campbell M, Heller S. Improved biomedical and psychological outcomes 1 year after structured education in flexible insulin therapy for people with type 1 diabetes: the U.K. DAFNE experience. *Diabetes Care.* 2012;35:1638–42.
- Hulkower RD, Pollack RM, Zonszein J. Understanding hypoglycemia in hospitalized patients. *Diabetes Manag (Lond).* 2014;4:165–76.
- Hvidberg A, Fanelli CG, Hershey T, Cryer PE. Impact of recent antecedent hypoglycemia on hypoglycemic cognitive dysfunction in nondiabetic humans. *Diabetes.* 1996;45:1030–26.
- International Hypoglycemia Study Group. Glucose concentrations of less than 3.0 mmol/L (54 mg/dL) should be reported in clinical trials: a joint position statement of the American Diabetes Association and the European Association for the Study of Diabetes. *Diabetes Care.* 2017;40:155–7.
- Jaap AJ, Jones GC, McCrimmon RJ, Deary IJ, Frier BM. Perceived symptoms of hypoglycemia in elderly type 2 diabetic patients treated with insulin. *Diabet Med.* 1998;15:398–401.
- Johnston SS, Conner C, Aagren M, Smith DM, Bouchard J, Brett J. Evidence linking hypoglycemic events to an increased risk of acute cardiovascular events in patients with type 2 diabetes. *Diabetes Care.* 2011;34:1164–70.
- Johnston SS, Conner C, Aagren M, Ruiz K, Bouchard J. Association between hypoglycemic events and fall-related fractures in Medicare-covered patients with type 2 diabetes. *Diabetes Obes Metab.* 2012;14:634–43.
- Judson WE, Hollander W. The effects of insulin-induced hypoglycemia in patients with angina pectoris before and after intravenous hexamethonium. *Am Heart J.* 1956;52:198–209.
- Kosiborod M, Inzucchi SE, Krumholz HM, Xiao L, Jones PG, Fiske S, Masoudi FA, Marso SP, Sertus JA. Glucometrics in patients hospitalized with acute myocardial infarction: defining the optimal outcomes-based measure of risk. *Circulation.* 2008;117:1018–27.
- Laiterapong N, Karter AJ, Liu JY, et al. Correlates of quality of life in older adults with diabetes: the diabetes & aging study. *Diabetes Care.* 2011;34:1749–53.
- Laitinen T, Lyyra-Laitinen T, Huopio H, Vauhkonen I, Halonen T, Hartikainen J, Niskanen L, Laakso M. Electrocardiographic alterations during hyperinsulinemic hypoglycemia in healthy subjects. *Ann Noninvasive Electrocardiol.* 2008;13:97–105.
- Leiter LA, Yale J-F, Chiasson JL, Harris S, Kleinstiver P, Sauriol L. Assessment of the impact of fear of hypoglycemic episodes on glycemic and hypoglycemia management. *Can J Diabetes.* 2005;29:186–92.

- Levin BE. Glucosensing neurons: the metabolic sensors of the brain? *Diabetes Nutr Metab*. 2002;15:274–80.
- Little SA, Leelarathna L, Walkinshaw E, Tan HK, Chapple O, Lubina-Solomon A, Chadwick TJ, Barendse S, Stocken DD, Brennand C, Marshall SM, Wood R, Speight J, Kerr D, Flanagan D, Heller SR, Evans ML, Shaw JA. Recovery of hypoglycemia awareness in long-standing type 1 diabetes: a multicenter 2 × 2 factorial randomized controlled trial comparing insulin pump with multiple daily injections and continuous with conventional glucose self-monitoring (Hypo-COMPASS). *Diabetes Care*. 2014;37:2114–22.
- Lubow JM, Piñón IG, Avogaro A, Cobelli C, Treason DM, Mandeville KA, Toffolo G, Boyle PJ. Brain oxygen utilization is unchanged by hypoglycemia in normal humans: lactate, alanine, and leucine uptake are not sufficient to offset energy deficit. *Am J Physiol Endocrinol Metab*. 2006;290:E149–53.
- Lucidi P, Porcellati F, Marinelli Andreoli A, Carriero I, Candeloro P, Cioli P, Bolli GB, Fanelli CG. Pharmacokinetics and pharmacodynamics of NPH insulin in type 1 diabetes: the importance of appropriate resuspension before subcutaneous injection. *Diabetes Care*. 2015;38:2204–10.
- Lundkvist J, Berne C, Bolinder B, Jönsson L. The economic and quality of life impact of hypoglycemia. *Eur J Health Econ*. 2005;6:197–202.
- Ly TT, Hewitt J, Davey RJ, Lim EM, Davis EA, Jones TW. Improving epinephrine responses in hypoglycemia unawareness with real-time continuous glucose monitoring in adolescents with type 1 diabetes. *Diabetes Care*. 2011;34:50–2.
- Ly TT, Nicholas JA, Retterath A, Lim RM, Davis EA, Jones TW. Effect of sensor-augmented insulin pump therapy and automated insulin suspension vs standard insulin pump therapy on hypoglycemia in patients with type 1 diabetes. *JAMA*. 2013;310:1240–7.
- Ly TT, Maahs DM, Rewers A, Dunger D, Oduwole A, Jones TW. ISPAD Clinical Practice Consensus Guidelines – Hypoglycemia: assessment and management of hypoglycemia in children and adolescents with diabetes. *Pediatr Diabetes*. 2014;15(Suppl 20):180–92.
- Marchesini G, Veronese G, Forlani G, Ricciardi LM, Italian Society of Emergency Medicine SIMEU. The management of severe hypoglycemia by the emergency system: the HYPOTHE-SIS study. *Nutr Metab Cardiovasc Dis*. 2014;24:1181–8.
- Matyka K, Evans M, Lomas J, Cranston I, Macdonald I, Amiel SA. Altered hierarchy of protective responses against severe hypoglycemia in normal aging in healthy men. *Diabetes Care*. 1997;20:135–41.
- McCall A, Fixman L, Fleming N, Tornheim K, Click W, Ruderman NB. Chronic hypoglycemia increases brain glucose transport. *Am J Phys*. 1986;251:E442–7.
- McCoy RG, Van Houten HK, Ziegenfuss JY, Shah ND, Wermers RA, Smith SA. Increased mortality of patients with diabetes reporting severe hypoglycemia. *Diabetes Care*. 2012;35:1897–901.
- Mellbin LG, Malmberg K, Waldenstrom A, Wedel H, Ryden L. Prognostic implications of hypoglycemic episodes during hospitalisation for myocardial infarction in patients with type 2 diabetes: a report from the DIGAMI 2 trial. *Heart*. 2009;95:721–7.
- Meneilly GS, Cheung E, Tuokko H. Altered responses to hypoglycemia of healthy elderly people. *J Clin Endocrinol Metab*. 1994;78:1341–8.
- Meyer C, Nadkarni V, Stumvoll M, Gerich J. Human kidney free fatty acid and glucose uptake: evidence for a renal glucose-fatty acid cycle. *Am J Phys*. 1997;273:E650–4.
- Mitrakou A, Ryan C, Veneman T, Mokan M, Jenssen T, Kiss I, Durrant J, Cryer P, Gerich J. Hierarchy of glycemic thresholds for counterregulatory hormone secretion, symptoms, and cerebral dysfunction. *Am J Phys*. 1991;260:E67–74.
- Mitrakou A, Fanelli C, Veneman T, Perriello G, Calderone S, Platanisiotis D, Rambotti A, Raptis S, Brunetti P, Cryer P, Bolli GB. Reversibility of unawareness of hypoglycemia in patients with insulinomas. *N Engl J Med*. 1993;329:834–9.
- Monami M, Dicembrini I, Kundisova L, Zannoni S, Nreu B, Mannucci E. A meta-analysis of the hypoglycemic risk in randomized controlled trials with sulfonylureas in patients with type 2 diabetes. *Diabetes Obes Metab*. 2014;16:833–40.

- Monnier L, Lapinski H, Colette C. Contributions of fasting and postprandial plasma glucose increments to the overall diurnal hyperglycemia of type 2 diabetic patients: variations with increasing levels of HbA(1c). *Diabetes Care*. 2003;26:881–5.
- Nathan DM, Buse JB, Davidson MB, Ferrannini E, Holman RR, Sherwin R, Zinman B, American Diabetes Association, European Association for Study of Diabetes. Medical management of hyperglycemia in type 2 diabetes: a consensus algorithm for the initiation and adjustment of therapy: a consensus statement of the American Diabetes Association and the European Association for the Study of Diabetes. *Diabetes Care*. 2009;32:193–203.
- Olsen SE, Asvold BO, Frier BM, Aune SE, Hansen LI, Bjørgaas MR. Hypoglycemia symptoms and impaired awareness of hypoglycemia in adults with type 1 diabetes: the association with diabetes duration. *Diabet Med*. 2014;31:1210–7.
- Östenson CG, Geelhoed-Duijvestijn P, Lahtela J, Weitgasser R, Markert Jensen M, Pedersen-Bjergaard U. Self-reported non-severe hypoglycemic events in Europe. *Diabet Med*. 2014;31:92–101.
- Ovalle F, Fanelli CG, Paramore DS, Hershey T, Craft S, Cryer PE. Brief twice-weekly episodes of hypoglycemia reduce detection of clinical hypoglycemia in type 1 diabetes mellitus. *Diabetes*. 1998;47:1472–9.
- Owen OE, Felig P, Morgan AP, Wahren J, Cahill GF Jr. Liver and kidney metabolism during prolonged starvation. *J Clin Invest*. 1969;48:574–83.
- Owens DR, Zinman B, Bolli GB. Insulins today and beyond. *Lancet*. 2001;358:739–46.
- Öz G, Kumar A, Rao JP, Kodl CT, Chow L, Eberly LE, Seaquist ER. Human brain glycogen metabolism during and after hypoglycemia. *Diabetes*. 2009;58:1978–85.
- Öz G, Tesfaye N, Kumar A, Deelchand DK, Eberly LE, Seaquist ER. Brain glycogen content and metabolism in subjects with type 1 diabetes and hypoglycemia unawareness. *J Cereb Blood Flow Metab*. 2012;32:256–63.
- Öz G, DiNuzzo M, Kumar A, Moheet A, Seaquist ER. Revisiting glycogen content in the human brain. *Neurochem Res*. 2015;40:2473–81.
- Paranjape SA, Chan O, Zhu W, Horblitt AM, McNay EC, Cresswell JA, Bogan JS, McCrimmon RJ, Sherwin RS. Influence of insulin in the ventromedial hypothalamus on pancreatic glucagon secretion in vivo. *Diabetes*. 2010;59:1521–7.
- Patel A, MacMahon S, Chalmers J, Neal B, Billot L, Woodward M, Marre M, Cooper M, Glasziou P, Grobbee D, Hamet P, Harrap S, Heller S, Liu L, Mancia G, Mogensen CE, Pan C, Poulter N, Rodgers A, Williams B, Bompoint S, de Galan BE, Joshi R, Travert F. Intensive blood glucose control and vascular outcomes in patients with type 2 diabetes. *N Engl J Med*. 2008;358:2560–72.
- Pedersen-Bjergaard U, Pramming S, Heller SR, Wallace TM, Rasmussen AK, Jørgensen HV, Matthews DR, Hougaard P, Thorsteinnsson B. Severe hypoglycemia in 1076 adult patients with type 1 diabetes: influence of risk markers and selection. *Diabetes Metab Res Rev*. 2004;20:479–86.
- Pinto DS, Skolnick AH, Kirtane AJ, Murphy SA, Barron HV, Giugliano RP, Cannon CP, Braunwald E, Gibson CM. U-shaped relationship of blood glucose with adverse outcomes among patients with ST-segment elevation myocardial infarction. *J Am Coll Cardiol*. 2005;46:178–80.
- Porcellati F, Lucidi P, Bolli GB, Fanelli CG. GLP-1 RAs as compared to prandial insulin after failure of basal insulin in type 2 diabetes: lessons from the 4B and Get-Goal DUO 2 trials. *Diabetes Metab*. 2015;41(6 Suppl 1):6S16–20.
- Razavi Nematollahi L, Kitabchi AE, Stentz FB, Wan JY, Larijani BA, Tehrani MM, Gozashti MH, Omidfar K, Taheri E. Proinflammatory cytokines in response to insulin-induced hypoglycemic stress in healthy subjects. *Metabolism*. 2009;58:443–8.
- Reichard P, Nilsson B-Y, Rosenquist U. The effect of intensive treatment of diabetes on the development and progression of long-term complications in insulin-dependent diabetes mellitus. *N Engl J Med*. 1993;329:304–9.
- Riddle MC, Rosenstock J, Gerich J. The treat-to-target trial: randomized addition of glargine or human NPH insulin to oral therapy of type 2 diabetic patients. *Diabetes Care*. 2003;26:3080–6.

- Ritter R, Slusser P, Stone S. Glucoreceptors controlling feeding and blood glucose: location in the hindbrain. *Science*. 1981;213:451–2.
- Robinson RT, Harris ND, Ireland RH, Lee S, Newman C, Heller SR. Mechanisms of abnormal cardiac repolarization during insulin-induced hypoglycemia. *Diabetes*. 2003;52:1469–74.
- Rooijackers HM, Wieggers EC, Tack CJ, van der Graaf M, de Galan BE. Brain glucose metabolism during hypoglycemia in type 1 diabetes: insights from functional and metabolic neuroimaging studies. *Cell Mol Life Sci*. 2016;73:705–22.
- Rossetti P, Porcellati F, Busciantella Ricci N, Candeloro P, Cioli P, Nair KS, Santeusanio F, Bolli GB, Fanelli CG. Effect of oral amino acids on counterregulatory responses and cognitive function during insulin-induced hypoglycemia in nondiabetic and type 1 diabetic people. *Diabetes*. 2008a;57:1905–17.
- Rossetti P, Porcellati F, Bolli GB, Fanelli CG. Prevention of hypoglycemia while achieving good glycemic control in type 1 diabetes. *Diabetes Care*. 2008b;31(Suppl 2):S113–20.
- Routh VH. Glucose-sensing neurons: are they physiologically relevant? *Physiol Behav*. 2002;76:403–13.
- Routh VH. Glucosensing neurons in the ventromedial hypothalamic nucleus (VMN) and hypoglycemia-associated autonomic failure (HAAF). *Diabetes Metab Res Rev*. 2003;19:348–56.
- Routh VH. Glucose sensing neurons in the ventromedial hypothalamus. *Sensors (Basel)*. 2010;10:9002–25.
- Samuel S, Goswami D, Shum K, Boye KS, Rengarajan B, et al. A model of mild hypoglycemia. *Curr Med Res Opin*. 2015;31:633–41.
- Seaquist ER, Miller ME, Bonds DE, Feinglos M, Goff DC Jr, Peterson K, Senior P, ACCORD Investigators. The impact of frequent and unrecognized hypoglycemia on mortality in the ACCORD study. *Diabetes Care*. 2012;35:409–14.
- Seaquist ER, Anderson J, Childs B, Cryer P, Dagogo-Jack S, Fish L, Heller SR, Rodriguez H, Rosenzweig J, Vigersky R. Hypoglycemia and diabetes: a report of a workgroup of the American Diabetes Association and the Endocrine Society. *Diabetes Care*. 2013;36:1384–95.
- Segel SA, Paramore DS, Cryer PE. Hypoglycemia-associated autonomic failure in advanced type 2 diabetes. *Diabetes*. 2002;51:724–33.
- Shichiri M, Kishikawa H, Ohkubo Y, Wake N. Long term results of the Kumamoto study on optimal diabetes control in type 2 diabetic patients. *Diabetes Care*. 2000;23:B21–9.
- Shimazu T, Fukuda A, Ban T. Reciprocal influence of the ventro-medial and lateral hypothalamic nuclei on blood glucose level and liver glycogen content. *Nature*. 1966;210:1178–9.
- Shorr RI, Ray WA, Daugherty JR, Griffin MR. Individual sulfonylureas and serious hypoglycemia in older people. *J Am Geriatr Soc*. 1996;44:751–5.
- Skyler JS, Bergenstal R, Bonow RO, Buse J, Deedwania P, Gale EA, Howard BV, Kirkman MS, Kosiborod M, Reaven P, Sherwin RS. Intensive glycemic control and the prevention of cardiovascular events: implications of the ACCORD, ADVANCE, and VA Diabetes Trials: a position statement of the American Diabetes Association and a Scientific Statement of the American College of Cardiology Foundation and the American Heart Association. *J Am Coll Cardiol*. 2009;53:298–304.
- Sommerfield AJ, Wilkinson IB, Webb DJ, Frier BM. Vessel wall stiffness in type 1 diabetes and the central hemodynamic effects of acute hypoglycemia. *Am J Physiol Endocrinol Metab*. 2007;293:E1274–9.
- Song Z, Levin BE, McArdle JJ, Bakhos N, Routh VH. Convergence of pre- and postsynaptic influences on glucosensing neurons in the ventromedial hypothalamic nucleus. *Diabetes*. 2001;50:2673–81.
- Spyer G, Hattersley A, MacDonald I, Amiel S, MacLeod H. Hypoglycemic counter-regulation at normal blood glucose concentrations in patients with well controlled type-2 diabetes. *Lancet*. 2000;356:1970–4.
- Stumvoll M, Chintalapudi U, Perriello G, Welle S, Gutierrez O, Gerich J. Uptake and release of glucose by the human kidney: postabsorptive rates and responses to epinephrine. *J Clin Invest*. 1995;96:2528–33.



- Stumvoll M, Meyer C, Kreider M, Perriello G, Gerich J. Effects of glucagon on renal and hepatic glutamine gluconeogenesis in normal postabsorptive humans. *Metabolism*. 1998a;47:1227–732.
- Stumvoll M, Meyer C, Perriello G, Kreider M, Welle S, Gerich J. Human kidney and liver gluconeogenesis: evidence for organ substrate selectivity. *Am J Phys*. 1998b;274:E817–26.
- Szoke E, Gosmanov NR, Sinkin JC, Nihalani A, Fender AB, Cryer PE, Meyer C, Gerich JE. Effects of glimepiride and glyburide on glucose counterregulation and recovery from hypoglycemia. *Metabolism*. 2006;55:78–83.
- Tattersall RB, Gill GV. Unexplained deaths of type 1 diabetic patients. *Diabet Med*. 1991;8:49–58.
- The Diabetes Control and Complications Trial Research Group. The effect of intensive treatment of diabetes on the development and progression of long-term complications in insulin-dependent diabetes mellitus. *N Engl J Med*. 1993;329:977–86.
- The UKPDS Research Group. Overview of 6 years of therapy of type II diabetes: a progressive disease. *Diabetes*. 1995;44:1249–58.
- Towler DA, Havlin CE, Craft S, Cryer P. Mechanism of awareness of hypoglycemia. Perception of neurogenic (predominantly cholinergic) rather than neuroglycopenic symptoms. *Diabetes*. 1993;42:1791–8.
- Uehara Y, Nipper V, McCall AL. Chronic insulin hypoglycemia induces GLUT-3 protein in rat brain neurons. *Am J Phys*. 1997;272:E716–9.
- UK Hypoglycemia Study Group. Risk of hypoglycemia in types 1 and 2 diabetes: effects of treatment modalities and their duration. *Diabetologia*. 2007;50:1140–7.
- UK Prospective Diabetes Study (UKPDS) Group. Intensive blood-glucose control with sulfonylureas or insulin compared with conventional treatment and risk of complications in patients with type 2 diabetes (UKPDS 33). UK Prospective Diabetes Study (UKPDS) Group. *Lancet*. 1998;352:837–53.
- van de Ven KC, van der Graaf M, Tack CJ, Heerschap A, de Galan BE. Steady-state brain glucose concentrations during hypoglycemia in healthy humans and patients with type 1 diabetes. *Diabetes*. 2012;61:1974–7.
- Vannucci SJ, Maher F, Simpson IA. Glucose transporter proteins in brain: delivery of glucose to neurons and glia. *Glia*. 1997;21:2–21.
- Veneman T, Mitrakou A, Mokan M, Cryer P, Gerich JE. Induction of hypoglycemia unawareness by asymptomatic nocturnal hypoglycemia. *Diabetes*. 1993;42:1233–7.
- Veronese G, Marchesini G, Forlani G, Saragoni S, Degli Esposti L, et al. Costs associated with emergency care and hospitalization for severe hypoglycemia. *Nutr Metab Cardiovasc Dis*. 2016;26:345–51.
- Vlcek M, Radikova Z, Penesova A, Kvetnansky R, Imrich R. Heart rate variability and catecholamines during hypoglycemia and orthostasis. *Auton Neurosci*. 2008;143:53–7.
- Wender R, Brown AM, Fern R, Swanson RA, Farrell K, Ransom BR. Astrocytic glycogen influences axon function and survival during glucose deprivation in central white matter. *J Neurosci*. 2000;20:6804–10.
- Weng J, Li Y, Xu W, Shi L, Zhang Q, Zhu D, Hu Y, Zhou Z, Yan X, Tian H, Ran X, Luo Z, Xian J, Yan L, Li F, Zeng L, Chen Y, Yang L, Yan S, Liu J, Li M, Fu Z, Cheng H. Effect of intensive insulin therapy on beta-cell function and glycaemic control in patients with newly diagnosed type 2 diabetes: a multicentre randomised parallel-group trial. *Lancet*. 2008;371:1753–60.
- White NH, Skor DA, Cryer PE, Levandoski LA, Bier DM, Santiago JV. Identification of type I diabetic patients at increased risk for hypoglycemia during intensive therapy. *N Engl J Med*. 1983;308:485–91.
- Whitmer RA, Karter AJ, Yaffe K, Quesenberry CP Jr, Selby JV. Hypoglycemic episodes and risk of dementia in older patients with type 2 diabetes mellitus. *JAMA*. 2009;301:1565–72.
- Woerle HJ, Meyer C, Popa EM, Cryer PE, Gerich JE. Renal compensation for impaired hepatic glucose release during hypoglycemia in type 2 diabetes: further evidence for hepatorenal reciprocity. *Diabetes*. 2003;52:1386–92.

- Woo VC. A review of the clinical efficacy and safety of insulin Degludec and Glargine 300 U/mL in the treatment of diabetes mellitus. *Clin Ther.* 2017;39:S12–33. pii: S0149-2918(17)30040-1.
- Workgroup on Hypoglycemia, American Diabetes Association. Defining and reporting hypoglycemia in diabetes: a report from the American Diabetes Association Workgroup on Hypoglycemia. *Diabetes Care.* 2005;28:1245–9.
- Wysham CH, Lin J, Kuritzky L. Safety and efficacy of a glucagon-like peptide-1 receptor agonist added to basal insulin therapy versus basal insulin with or without a rapid-acting insulin in patients with type 2 diabetes: results of a meta-analysis. *Postgrad Med.* 2017;15:1–10.
- Yaffe K, Falvey CM, Hamilton N, Harris TB, Simonsick EM, Strotmeyer ES, Shorr RI, Metti A, Schwartz AV, Health ABC Study. Association between hypoglycemia and dementia in a biracial cohort of older adults with diabetes mellitus. *JAMA Intern Med.* 2013;173:1300–6.
- Yeoh E, Choudhary P, Nwokolo M, Ayis S, Amiel SA. Interventions that restore awareness of hypoglycemia in adults with type 1 diabetes: a systematic review and meta-analysis. *Diabetes Care.* 2015;38:1592–609.



Riki Bergel, Eran Hadar, Yoel Toledano, and Moshe Hod

## Contents

Introduction .....	654
Epidemiology .....	654
Pathophysiology .....	654
Classification and Diagnosis of Hyperglycemia in Pregnancy .....	655
Adverse Pregnancy Outcomes in Pregnancies Complicated by Diabetes .....	659
Management of Gestational Diabetes Mellitus .....	662
Postpartum Management .....	673
References .....	675

## Abstract

Gestational diabetes mellitus (GDM) is a state of glucose intolerance, which is diagnosed during pregnancy (ACOG 2013). It is one of the most common gestational-related morbidities and imposes various risks and complications for both, mother and fetus. The consequences of these complications persist not only during gestation but also immediately after delivery and may impact health well into adulthood and as such aggravate outcomes of future pregnancies of the mother and her offspring. Thereby, GDM influences national healthcare many years after its occurrence. In an era in which obesity and diabetes mellitus are an epidemic, special attention to diagnosis and management of GDM women should be taken into consideration (Hod et al. 2015), as a possible window of opportunity to improve immediate and long-term health consequences.

R. Bergel · E. Hadar · Y. Toledano · M. Hod (✉)  
Helen Schneider's Hospital for Women, Rabin Medical Center, Petah-Tikva, Israel  
Sackler Faculty of Medicine, Tel Aviv University, Tel Aviv, Israel  
e-mail: [hodroyal@inter.net.il](mailto:hodroyal@inter.net.il)

---

**Keywords**Pregnancy · Gestational diabetes mellitus · Oral antidiabetic agents · Insulin

---

**Introduction**

Gestational diabetes mellitus (GDM) is a state of glucose intolerance, which is diagnosed during pregnancy (ACOG 2013). It is one of the most common gestational-related morbidities and imposes various risks and complications for both, mother and fetus. The consequences of these complications persist not only during gestation but also immediately after delivery and may impact health well into adulthood and as such aggravate outcomes of future pregnancies of the mother and her offspring. Thereby, GDM influences national healthcare many years after its occurrence. In an era in which obesity and diabetes mellitus are an epidemic, special attention to diagnosis and management of GDM women should be taken into consideration (Hod et al. 2015), as a possible window of opportunity to improve immediate and long-term health consequences.

---

**Epidemiology**

Previous reports have estimated that about 6% of pregnancies are complicated by hyperglycemia, the majority of which are GDM diagnosed during gestation (ACOG, 2013). The prevalence of GDM differs between countries and populations, depending on multiple factors including the applied screening and diagnosis modalities; personal, familial, and environmental risk factors; as well as the rate of type 2 diabetes mellitus (T2DM) among the studied population (Kampmann et al. 2015). Due to similarities in predisposition and pathogenesis, the increasing prevalence of T2DM, in a given population, and particularly among younger people, has led to an increasing number of pregnancies complicated with hyperglycemia, either GDM or T2DM. Jiwani et al. (2012) and McIntyre et al. (2014) determined the worldwide prevalence of GDM at a wide range of 5–20%, in both, developed and developing countries. Recent reports from the International Diabetes Federation (IDF) estimated that the overall worldwide prevalence of hyperglycemia in pregnancy, in 2013, was 16% of the total live births (International Diabetes Federation 2015).

---

**Pathophysiology**

Adaptation to pregnancy begins immediately and shortly after the implantation, conferring substantial maternal physiological changes (Fallis 2016). A major change is hyperplasia and hypertrophy of pancreatic  $\beta$ -cells in the islets of Langerhans. These changes are attributed to hormonal stimulation derived by estrogen and progesterone. In contrast to a seemingly normal basal insulin secretion,

postprandial insulin levels are elevated, mainly due to an increase in synthesis and secretion of insulin.

Glucose crosses the placenta by facilitated diffusion during early pregnancy, in order to supply the high demand for fetal glucose. This may cause maternal fasting hypoglycemia, especially during early gestational weeks. At later stages of gestation, peripheral insulin resistance develops and increases gradually throughout the first and second trimesters. This is related to an elevation of several hormones, counter-regulating the action of insulin, including human placental lactogen (HPL), glucocorticoids, and progesterone, as well as free fatty acids and tumor necrosis factor- $\alpha$ . Accordingly, glucose ingestion in late pregnancy results in higher and more sustained levels of glucose and insulin compared to nonpregnant subjects.

The glycemic profile in the second half of nondiabetic pregnancy was characterized by studies using continuous glucose monitoring (CGM) (Yogev et al. 2004a). In nonobese, nondiabetic women, the difference in glucose levels between fasting and preprandial values during the day was minimal – suggesting that fasting plasma levels may reflect preprandial values (Yogev et al. 2004a). However, mean blood glucose levels during nighttime were significantly lower than daytime levels. In a recent study, CGM confirmed that diurnal glucose patterns throughout the day are reduced by 20% as well as the percent of time in hypoglycemia is significantly higher in the pregnant versus nonpregnant states (Mazze et al. 2012).

---

## Classification and Diagnosis of Hyperglycemia in Pregnancy

Until recently, the accepted definition for GDM was “any degree of glucose intolerance with first onset or recognition during pregnancy” (Yogev et al. 2004a). This definition includes women with preexisting diabetes, either type 1 diabetes mellitus (T1DM) or T2DM, who were not identified prior to pregnancy. As this definition blurs the line between morbidities associated with diabetes antedating pregnancy and those related to GDM, reintroduced efforts are made in order to rectify the definition and classification of hyperglycemia in pregnancy. Accordingly, if hyperglycemia is first detected at any time during pregnancy, it should be classified either as diabetes mellitus in pregnancy (DIP) or GDM (American Diabetes Association [ADA] 2013) (Fig. 1).

**Diabetes in pregnancy (DIP):** DIP may be either preexisting diabetes – T1DM or T2DM – antedating and diagnosed prior to pregnancy or diabetes which was first diagnosed during pregnancy. Importantly, if hyperglycemia is present at conception and embryogenesis, it significantly increases maternal vulnerability and fetal risks for early complications related to hyperglycemia (Landon and Gabbe 2011). Such risks of hyperglycemia at the critical period of organogenesis may lead to spontaneous abortions and congenital anomalies. Additionally, there is a risk of onset or exacerbation of diabetes-related complications, such as retinopathy or nephropathy, respectively.

When the level of hyperglycemia first detected by testing at any time during gestation meets the criteria for diagnosis of diabetes in the nonpregnant state (Table 1), the woman should be diagnosed with DIP. Those criteria are fasting plasma glucose (FPG) of 7.0 mmol/L (126 mg/dL) and above and/or a 2-h 75 g

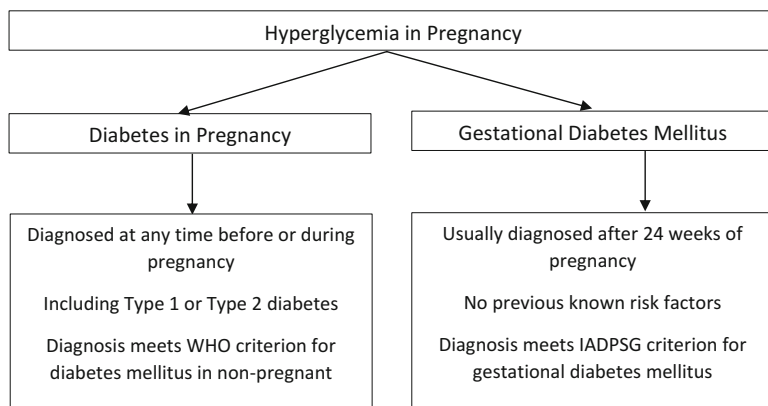

**Fig. 1** Classification of hyperglycemia in pregnancy (Hod et al. 2015)

**Table 1** Diagnostic methods and thresholds for diabetes in pregnancy

Measure of glycemia	Threshold		Remarks
Fasting plasma glucose	$\geq 7.0$ mmol/L	$\geq 126$ mg/dL	
Hemoglobin A1c	$\geq 6.5\%$		In standardized laboratories
2-h 75 g glucose	$\geq 11.1$ mmol/L	$\geq 200$ mg/dL	
Random plasma glucose	$\geq 11.1$ mmol/L	$\geq 200$ mg/dL	Accompanied by signs and symptoms

oral glucose tolerance test (OGTT) value of 11.1 mmol/L (200 mg/dL) and above or a random plasma glucose (RPG) of 11.1 mmol/L (200 mg/dL) and above, accompanied by signs and symptoms suggestive of diabetes.

**Gestational diabetes mellitus:** When hyperglycemia is detected during routine testing during pregnancy (generally, but not exclusively between 24 and 28 gestational weeks), but it does not meet the above-mentioned criteria for DIP, it should be classified as GDM. Due to its usual diagnosis and appearance at later gestational weeks, and with less severe hyperglycemic levels, GDM implies a relatively milder form of hyperglycemia compared to DIP. Nevertheless, GDM is still associated with a heightened risk of adverse pregnancy outcome and maternal risks.

Historically, screening tests for GDM were carried out only for women at risk, according to personal, medical, and familial history (ACOG 2013). In 1973, O'Sullivan and Mahan proposed the 50 g, 1-h oral glucose challenge test (O'Sullivan et al. 1973). The test has become widely used for more than 95% of obstetric groups in the USA. However, consistent data demonstrate this test is not suitable for all pregnant women (Force USPST 2008), and currently it is accepted only as a screening test to detect women who are at high risk for GDM. When high-risk factors exist – either by history taking or glucose challenge test (GCT) – the accepted method for diagnosis of GDM, in the past decades, was the 100 g 3-h oral glucose tolerance test (GTT), using either the National Diabetes Data Group

**Table 2** Screening and diagnosis strategy for GDM according to ACOG recommendations

Low risk	Blood glucose testing not routinely required	<p><b>If all of the following characteristics are present:</b></p> <ul style="list-style-type: none"> <li>• Ethnicity of low-prevalence GDM</li> <li>• No known diabetes in first-degree relatives</li> <li>• Age <math>\geq</math> 25 years</li> <li>• Normal weight before pregnancy and at birth</li> <li>• History of abnormal glucose metabolism</li> <li>• No history of poor obstetric outcome</li> </ul>
Average risk	<p>Glucose testing at 24–28 weeks:</p> <ul style="list-style-type: none"> <li>• <b>Two-step procedure:</b> 50 g GCT followed by a diagnostic OGTT if GCT cutoff is met</li> <li>• <b>One-step procedure:</b> diagnostic OGTT performed on all subjects</li> </ul>	If none of the low-risk or high-risk criteria are fulfilled
High risk	<p>Perform blood glucose testing as soon as feasible, using one- or two-step procedure</p> <p>If GDM is not diagnosed, blood glucose testing should be repeated at 24–28 weeks or at any time a patient has symptoms or signs suggestive of hyperglycemia</p>	<p><b>If any one of the above or one or more of these are present:</b></p> <ul style="list-style-type: none"> <li>• Severe obesity</li> <li>• Strong family history of T2D</li> <li>• Previous history of GDM, impaired glucose metabolism, or glucosuria</li> </ul>

GDM, gestational diabetes mellitus; GCT, glucose challenge test; OGTT, oral glucose tolerance test

(1979) or the Carpenter and Coustan criteria (Carpenter and Coustan 1982). This test is usually done when GCT is pathological (as a two-step procedure) or when other high-risk criteria for GDM are present (as a single-step procedure) and may be employed selectively for high-risk groups or universally for the entire population. It is considered to be the gold standard for diagnosing GDM. Both diagnostic criteria require two or more abnormal values for the diagnosis of GDM (Table 2). Despite repeated reports of the association between one abnormal value on the OGTT results and adverse outcome in pregnancy, the use of one abnormal value for the diagnosis of GDM remains controversial and is not widely accepted (Hod and Yogev 2010).

Global healthcare organizations and professional bodies have advocated a plethora of diverse algorithms for screening and diagnosis of GDM. Unfortunately, even the endocrine, diabetes, and obstetric associations within particular countries often used markedly dissimilar protocols and cutoff values for screening and diagnosis of GDM. These recommendations for GDM were criticized for lacking validation, as they were developed based on tenuous data, the result of expert opinions, were biased owing to economic considerations, or convenience-oriented (Agarwal 2010), thereby, creating confusion and uncertainty among care providers. One underlying yet fundamental problem, as shown consistently by several studies and primarily by

the Hyperglycemia and Adverse Pregnancy Outcome (HAPO) Study, is that the risk of poor pregnancy outcomes associated with hyperglycemia is continuous with no clear cutoff points (Group HSCR et al. 2008; Sacks et al. 1995; Sermer et al. 1995; Jensen et al. 2001; Schmidt et al. 2001).

It is, therefore, clear that any set of criteria for the diagnosis of GDM proposed will need to evolve from a consensus approach, balancing risks, and benefits of social, economic, and clinical contexts (McIntyre et al. 2015). Apart from the different cutoff values, the lack of consensus among the different professional bodies for an algorithm for screening and diagnosis of GDM is perhaps an even larger problem. Despite repeated pleas for a single process and criteria (Sacks 2014), the ideal protocol for the diagnosis of GDM continues to be debated. In 2010, the International Association of Diabetes in Pregnancy Study Groups (IADPSG) proposed consensus-derived cutoff values for fasting, 1-h, and 2-h 75 g OGTT threshold values, defining GDM based on odds ratio thresholds of 1.75 in comparison with the mean, for the markers of diabetic fetopathy (large for gestational age, excess fetal adiposity, and fetal hyperinsulinemia) in the HAPO study (Metzger 2010). These criteria have been widely accepted and recently adopted by the World Health Organization (WHO), the American Diabetes Association (ADA), and the International Diabetes Federation (Group WGD 2013; ADA 2012; Guariguata et al. 2014).

Selective testing based on clinical risk factors for GDM evolved from the view that in populations with a low risk of GDM, subjecting all pregnant women to a laboratory test was not considered cost-effective. Some of the aforementioned risk factors used were age and body mass index (BMI) (at varying thresholds), ethnicity, polyhydramnios, macrosomia (current or past pregnancy), GDM in the past, unexplained stillbirth, T2DM in a first-degree relative, and polycystic ovary syndrome (PCOS). The major problem of risk factor-based screening is its high demand on the healthcare providers with more complex protocols for testing, which results in lower compliance by both, patients and healthcare providers. Given the high rates of hyperglycemia in pregnancy in most populations and that selective testing based on known risk factors has poor sensitivity for detection of GDM (Naylor et al. 1997), it seems appropriate to recommend universal rather than risk-based testing (Moses and Cheung 2009; Simmons and Moses 2013), especially among ethnic populations considered to be at high risk with a high prevalence of T2DM (Nielsen et al. 2012).

Currently, there are two acceptable pathways for diagnosing GDM: (1) a two-step or single-step algorithm (of a 50 g GCT followed by the 100 g OGTT), either selective or universal which is advocated by the American Congress of Obstetricians and Gynecologists (ACOG) (2013) (Table 2), and (2) single-step 75 g OGTT in all women that is endorsed by the WHO, IDF, FIGO, and many other organizations that endorsed IADPSG recommendations (International Diabetes Federation [IDF] 2015; McIntyre et al. 2015; Group WGD 2013) (Table 3). The various cutoffs of the 75 and 100 g test, in each of the suggested strategies, are presented in Table 4.



**Table 3** Screening and diagnosis strategy for GDM and DIP according to IADPSG recommendations

<b>First prenatal visit</b>	Measure one of the following, on all or only high-risk women: <ul style="list-style-type: none"> <li>• FPG</li> <li>• HbA1c</li> <li>• RPG</li> </ul>	If results indicate overt diabetes as per Table 1	Preexisting diabetes
		If results not diagnostic of DIP as per Table 1 and FPG is 92–126 mg/dL (5.1–7.0 mmol/L)	GDM
		If results not diagnostic of overt diabetes as per Table 1 and FPG <92 mg/dL (5.1 mmol/L)	Test for GDM at 24–28 weeks
<b>24–28 weeks</b>	Perform 75 g OGTT on all women not previously diagnosed with overt diabetes or GDM	If fasting plasma glucose $\geq$ 126 mg/dL (7.0 mmol/L)	Preexisting diabetes
		If one or more values $\geq$ thresholds as per Table 4	GDM
		If all values < thresholds as per Table 4	Normal

GDM, gestational diabetes mellitus; FPG, fasting plasma glucose; HbA1c, glycosylated hemoglobin A1c; RPG, random plasma glucose; OGTT, oral glucose tolerance test; DIP, diabetes in pregnancy

**Table 4** Diagnosis of GDM by an oral glucose tolerance test

	100 g glucose load				75 g glucose load	
	Carpenter and Coustan		NDDG		IADPSG	
	mg/dL	mmol/L	mg/dL	mmol/L	mg/dL	mmol/L
Fasting	95	5.3	105	5.8	<b>92</b>	<b>5.1</b>
1 h	180	10.0	190	10.6	<b>180</b>	<b>10.0</b>
2 h	155	8.6	165	9.2	<b>153</b>	<b>8.5</b>
3 h	140	7.8	145	8/0	–	–

OGTT, oral glucose tolerance test; NDDG, National Diabetes Data Group; WHO, World Health Organization; ADA, American Diabetes Association

## Adverse Pregnancy Outcomes in Pregnancies Complicated by Diabetes

Pregnancies complicated by various forms of hyperglycemia are subject to short- and long-term complications which may arise throughout pregnancy, delivery, and postpartum (Table 5). Glucose and possibly other metabolites account for the pathogenesis of these adverse outcomes, as they create an altered environment in which the fetus is exposed to changes in gene expression, free oxygen radicals, cellular damage, impaired metabolic environment, and increased teratogenesis (Carrapato and Marcelino 2001). Importantly, the rate of these complications is closely related to the degree of pregestational, periconceptual, and antenatal glycemic control, respectively.

**Table 5** Diabetes-related morbidity

Maternal	Fetal	Neonatal	
Hypertensive disorders	Abortion	Short-term (infant)	Long-term (child and adult)
Urinary and genital tract infections	Stillbirth	Respiratory morbidity	Type 2 diabetes mellitus
Cesarean delivery	Congenital anomalies	Neonatal intensive care unit (NICU) admission	Obesity
Future T2DM (if GDM)	LGA	Hypoglycemia	Gestational diabetes (if female)
		Hyperbilirubinemia	
	Macrosomia		
Polyhydramnios	Preterm birth		
Instrumental delivery	Birth injury		
Traumatic labor			
Shoulder dystocia			

GDM, gestational diabetes mellitus; LGA, large for gestational age

**Congenital anomalies:** Major congenital anomalies are the primary contributor to perinatal mortality and morbidity for the offspring of a mother with diabetes in pregnancy, accounting for 30–50% of perinatal mortality, related to diabetes. There is a three- to fivefold increase in the incidence of congenital anomalies in infants of mothers with T1DM or T2DM, rising from approximately 2–4% incidence in the general population to 6–11% in the diabetic population. The congenital malformation rate is inversely related to maternal age at onset of diabetes and directly related to the level of glycemic control prior to pregnancy and during early gestation (Towner et al. 1995). The diabetes-related malformations do not involve a specific target organ. Rather, cardiac, central nervous, genitourinary, and gastrointestinal systems may be implicated. Specific anomalies include neural tube defects, holoprosencephaly, ventricular septal defects, and transposition of the great vessels. Caudal dysplasia is highly characteristic, and although it occurs more frequently in diabetic pregnancies, it is still rare and not pathognomonic.

Anomalies occur early in pregnancy, during the period of organogenesis, usually up until the seventh week of gestation. Hence, the critical time for glycemic control is at a time period where women are either not pregnant, unaware of their pregnancy, or aware but still not seeking prenatal care. Therefore, management and counseling of women with diabetes should begin prior to conception (ACOG 2005a); however, only 30–50% of pregnancies are planned, and mothers receive proper preconception care (Kim et al. 2005; Jack 1990; KA 2002; Moos 2003, 2010). Lack of preconception care and prepregnancy uncontrolled diabetes are associated with an increased malformation rate (Johnson et al. 2006; Cox et al. 1992; ACOG 2005b). Appropriate pregnancy planning and glycemic control may decrease the rate of congenital anomalies to a comparable rate of the background population.

Good glycemic control exposes adequate levels of glucose, insulin, and ketones which are involved in the pathogenesis of malformations. Mean glucose level  $<100$  mg/dL (5.6 mmol/L) is associated with a low incidence of anomalies, as well as HbA1c of less than 7%.

**Spontaneous abortions:** The risk for a spontaneous abortion is also correlated to the degree of glycemic control. Good control, with normal HbA1c, reduces the risk of miscarriage to similar levels of the nondiabetic population. Mills et al. (1988) found that diabetic women with good glycemic control had the same rate of spontaneous abortions as normal population. Diabetic women with a high rate of spontaneous abortions had higher fasting/postprandial glucose levels. Women with very poor control diabetes had an increase of 3.1% in pregnancy rate loss.

**Stillbirth:** Stillbirth was a common complication in diabetic pregnancies and has become a rare event nowadays. Hyperglycemia is involved in the pathogenesis of several factors leading to stillbirth – mainly congenital anomalies, fetal hypoxemia and acidemia, placental insufficiency, and macrosomia. Maternal hyperglycemia is translated into hyperinsulinemia, mediated by hyperplasia of fetal pancreatic islet cells. Pedersen and others (Pedersen et al. 1974; Salvesen et al. 1993) have linked it to cord blood acidemia and hypoxemia, which are related to increased rates of stillbirth. The risk for fetal demise is also related to hypertension, vascular complications, polyhydramnios, and growth restriction, mainly those with T1D and T2D.

As for other complications, stillbirth is inversely related to the level of glycemic control. Mean blood glucose  $<100$  mg/dL is associated with low perinatal mortality rate (Weiss 1988).

**Macrosomia and large for gestational age:** Macrosomia is defined as birth weight above 4000 g and large for gestational age (LGA) as birth weight above the 90th percentile, according to sex and gestational age (Chatfield 2001; Xu et al. 2010). Macrosomia is related to increased risk of stillbirth, shoulder dystocia, asphyxia, and birth trauma and an increased rate of operative and Cesarean deliveries (Johns et al. 2006; Jones 2001). Good glycemic control may decrease the rates of macrosomia from 30–50% to as low as 0–22%, depending on glucose values. Tight glycemic control leads to 0%, 9%, and 11% macrosomia rate with respective mean blood glucose values of 80–87 mg/dL, less than 110 mg/dL, and 105–121 mg/dL (Kitzmilller et al. 1978; Jovanovic et al. 1981; Landon et al. 1987). It has been suggested that third trimester non-fasting glucose values, especially the 1-h postprandial glucose, are best correlated with the risk of macrosomia (Langer 1991; Langer and Mazze 1988; Langer et al. 1994).

**Neonatal complications:** There is an increased risk for neonatal complications related to high glucose levels during pregnancy and labor. The most immediate complication is hypoglycemia resulting in high insulin levels; this can lead to seizures and NICU admissions (Reece 2010). Moreover, there is an increased risk for respiratory distress syndrome (RDS), especially for LGA neonates (Jones 2001). Babies born to GDM mothers have higher risk for respiratory distress syndrome compared to normal population, even at full term but mostly at prematurity. This is related insufficiency of surfactant creation and lung structural immaturity (De Luca et al. 2009). Another neonatal morbidity is jaundice; it results from liver insufficiency to process bilirubin (Reece 2010).

**Long-term fetal complications:** Babies born to GDM mothers are more prone to have impaired glucose tolerance (IGT), diabetes mellitus, obesity, and neuropsychological dysfunction. This may be attributed to hyperglycemia during pregnancy and maternal lipid metabolism disturbances (Weintrob et al. 1996). According to the Freinkel's hypothesis (Freinkel 1980), the abnormal mixture of metabolites from the mother gains access to the developing fetus in utero, modifying the phenotypic expression in newly formed cells, which in turn determine permanent, short-, and long-term effects in the offspring.

---

## Management of Gestational Diabetes Mellitus

**Preconception care for pregestational diabetes:** About 50% of all pregnancies are unplanned and do not have the advantages of preconception care. Congenital anomalies and spontaneous abortions are more serious complications in pregestational diabetes than in GDM. Preconception counseling for women with pregestational diabetes mellitus has been reported to be beneficial and cost-effective and should be encouraged. A search for underlying vasculopathy is advisable and, in selected patients, may include a retinal examination, estimation of urinary protein excretion (albumin-creatinine ratio, protein-creatinine ratio, or 24-h urinary collection for protein), renal function (eGFR or creatinine clearance), and electrocardiography. Due to comorbidity with type 1 diabetes mellitus, thyroid function studies also should be obtained. Folic acid should be prescribed to all women contemplating pregnancy, which is particularly important in women with diabetes given their increased risk of neural tube defects (Hod et al. 2015; Hod and Yogev 2010).

**Management of diabetes in pregnancy:** The intensified management of GDM and pregestational diabetes is aimed at achieving best possible levels of glycemic control while avoiding hypoglycemia. It involves a multidisciplinary team effort which guides the patient for frequent self-monitoring of blood glucose (SMBG), lifestyle modification of nutrition and exercise, oral antidiabetic medications, or multiple daily injections of insulin, as needed. This approach often makes the difference between success and failure in the management of diabetes in pregnancy, aimed at achieving optimal glucose control.

**Glucose monitoring in women with GDM:** The optimal schedule, frequency, and timing of daily glucose monitoring remain unresolved. There are no evidence from randomized controlled trials (RCTs) to support any specific frequency. There are two RCTs for the management of GDM, of which the focus was not on the frequency of glucose monitoring. Landon et al. (2009) stated that patients were instructed to test glucose at fasting and 2-h postprandial, without stating how often they should test throughout the day. The Australian Carbohydrate Intolerance Study in Pregnant Women (ACHOIS) Study (Crowther et al. 2005) recommended that patients should monitor their blood glucose levels initially four times a day and then switch to "daily monitoring at rotating times." In an observational study, Langer et al. (1989) requested patients to test themselves seven times a day (although they actually tested themselves at a mean of 4.2 times a day). Currently accepted guidelines are also equivocal. The

National Institute for Health and Care Excellence (NICE) suggests that personnel should advise women who need intensification of hypoglycemic therapy to increase the frequency of self-monitoring to include fasting and a mixture of pre- and postprandial levels (Walker 2008). ACOG states (ACOG 2013) “There is insufficient evidence concerning the optimal frequency of blood glucose testing of GDM. Based on the data available, the general recommendation is four times daily glucose monitoring performed at fasting and either at 1-h or 2-h intervals after each meal. Once the patient’s glucose levels are well-controlled by her diet, the frequency of glucose monitoring can be modified.” In its 2015 clinical practice recommendations, the ADA encourages pre- and postprandial monitoring of blood glucose but does not recommend a specific frequency of testing (ADA 2015).

**Glycemic goals:** Although there is ample evidence that there is an association between glycemic control and the occurrence of maternal/fetal complications, this association does not prove cause and effect. It does, however, provide the rationale to attempt to achieve optimal glucose control. However, this optimum is not yet established by proper evidence; the accepted glycemic metabolic goals are detailed in Table 6.

**Weight gain during pregnancy:** The Institute of Medicine (IOM) has published recommendations for weight gain during pregnancy, based on prepregnancy body mass index (BMI) (No Title 2009; The ACOG 2013). However, there is no evidence allowing to make specific recommendations for weight gain during pregnancies complicated by diabetes.

According to IOM guidelines for weight-appropriate and underweight women, to ensure normal infant birth weight, a recommended weight gain with no restriction in caloric intake is recommended. For overweight and obese women, there is no consensus regarding caloric intake and weight gain during pregnancy. Some evidence suggests that weight reduction may be appropriate (Artal et al. 2007), whereas other studies indicate that in overweight and obese women, weight loss or gain of less than or equal to 5 kg during pregnancy is associated with an increased risk of small for gestational age (SGA) and decreased neonatal fat mass, lean mass, and head circumference (Catalano et al. 2014). Recommendations for weight gain during pregnancy and during pregnancy in women with GDM are given in Table 7.

**Fetal assessment:** The main contributor to perinatal mortality and morbidity for the offspring of the patient with pregestational diabetes is congenital malformations of the fetus. Abnormalities commonly affect the central nervous system, heart, and

**Table 6** Recommended capillary blood glucose target values for patients with gestational diabetes mellitus

	ACOG	ADA	NICE	FIGO
	(mg/dL)			
Fasting glucose	<95	<95	<95	<95
1-h postprandial glucose	<130–140	<140	<140	<140
2-h postprandial glucose	<120	<120	<115	<120

ACOG, American Congress of Obstetricians and Gynecologists; ADA, American Diabetes Association; NICE, National Institute for Health and Care Excellence; FIGO, Federation of Gynecology and Obstetrics

**Table 7** Weight gain recommendations during pregnancy – Institute of Medicine

Pregnancy body mass index	Total weight gain (kg)	Mean weight gain – second and third trimesters (kg/weeks)
Underweight <18.5	12.5–18	0.5 (0.44–0.58)
Normal weight 18.5–24.9	11.5–16	0.42 (0.35–0.5)
Overweight 25–29.9	7–11.5	0.28 (0.23–0.33)
Obese >30	5–9	0.22 (0.17–0.27)

BMI calculated as weight (kg) divided by the height in meter square

genitourinary and gastrointestinal systems, respectively. Detection of congenital anomalies should be initiated as early as the first trimester of pregnancy and repeated in the second trimester. If possible, early anomaly scan using transvaginal ultrasonography may be helpful (14–16 weeks); a basic examination is mandatory in the second trimester of pregnancy. Antepartum fetal monitoring including fetal movement counting, the nonstress test, the biophysical profile, and the contraction stress test – can be used to monitor women with pregnancy complicated by diabetes. Initiation of testing is appropriate for most patients at 32–34 weeks of gestation, but testing at earlier gestational ages may be warranted in some pregnancies complicated by additional high-risk conditions. The primary clinical value of current antepartum fetal monitoring tests is their low false-negative rate and ability to reassure the clinician that the fetus with normal test results is unlikely to die in utero. In a metabolically stable patient, such testing, therefore, allows prolongation of pregnancy with continued fetal maturation (Hod and Yogev 2010; NHS 1972).

**Diet and nutrition adjustments:** Lifestyle modifications are the cornerstone of treatment for all types of diabetes, with a dietary nutrition plan, being the foundation. Patient education and adapted physical exercise routines should be combined with the diet plan. Currently, two nutritional approaches are recommended: decreasing the proportion of carbohydrates to 35–40% in a daily regimen of 3 meals and 3–4 snacks and lowering glycemic index carbohydrates for approximately 60% of daily intake (Gunderson 2004; Kulkarni et al. 1998).

A regimen of small and frequent meals leads to better satiety and compliance, with a reduction of postprandial glucose peaks.

**Carbohydrates:** Insulin resistance is highest in the morning. Postprandial glucose levels are directly influenced by the amount of carbohydrate in the consumed food. Therefore, carbohydrate-based calories should be consumed at later times of the day, and breakfast should only be a small meal.

**Caloric intake:** Restricting calories has been a strategy for controlling weight gain, glucose levels, and avoiding macrosomia in women with GDM and their babies. Successful pregnancy outcomes have been reported within a wide range of caloric intake ranging from 1500 to 2800 calories per day (Knopp et al. 1991; Algert et al. 1985; Magee et al. 1990; Rae et al. 2000; Rizzo et al. 1991; Jovanovic et al. 1998). However, most studies were small sized and uncontrolled and relied on self-reported dietary intakes. Existing data suggest that severe caloric restriction (less than 1500 calories/day or 50% restriction) increases ketonemia. This is of particular significance

in women with T1DM in pregnancy where high levels of third trimester ketone bodies may impair mental development of the offspring (Algert et al. 1985). Modest caloric restriction (1600–1800 calories/day, 33% reduction) does not lead to ketosis (ADA 2000a, 2004). Daily energy intake of approximately 2000 calories in all BMI categories in women with GDM was reported to reduce weight gain, maintain euglycemia, avoid ketonuria, and achieve average birth weights of 3542 g (Foyett 2000; Snyder et al. 1994).

**Physical activity:** Postprandial blood glucose levels and insulin sensitivity may improve control by an appropriate exercise programmed. However, pregnant diabetic women need to be willing as well as able (socioeconomic limitations, obesity, and multiparity) to participate.

Physical activity in nonpregnant patients with diabetes has been shown to improve metabolic control, reduce insulin resistance, reduce cardiovascular risk, and improve weight control and overall well-being (ADA 2005). Women with GDM may achieve reduced glucose levels (up to 1.3 mmol/L/23 mg/dL) with 30 min of physical activity (Avery and Walker 2001). Studies evaluating the type, timing, duration, and compliance with physical activity regimens are warranted to best inform obstetric guidelines (Russo et al. 2015). Regular aerobic exercise with proper warm-up and cool down has been shown to lower fasting and postprandial glucose concentrations in several small studies of previously sedentary women with GDM. Safety of prescribed exercises for glucose management has not been demonstrated; therefore, women should be advised to monitor fetal activity and blood glucose levels, before and after exercise. Recommendations for physical activity in women with GDM are given in Fig. 2.

**Oral antidiabetic agents:** Traditionally, when dietary therapy fails to achieve and maintain normoglycemia in women with GDM, insulin was the only available medical therapy (ACOG technical bulletin. . . 1995; Jovanovic 1998). In the past, oral antidiabetic medications were not recommended during pregnancy owing to the fear of potential adverse fetal effects including teratogenicity and neonatal hypoglycemia (Zucker and Simon 1968; Farquhar and Isles 1968; Kembal et al. 1970; Smoak and Sadler 1990; Denno and Sadler 1994). However, this was principally based on case series involving the use of first-generation sulfonylureas (Zucker and Simon 1968; Farquhar and Isles 1968; Kembal et al. 1970; Sutherland et al. 1973, 1974; Letter 1974; Coetzee and Jackson 1984; Piacquadio et al. 1991). Although neither glyburide nor metformin is approved by FDA for treating diabetes during pregnancy, their use as an adjunct therapy in GDM has been considered by several organizations, such as NICE (Walker 2008) and ACOG (2013). Glyburide and

**Recommendations for physical activity in women with gestational diabetes mellitus.**

- Planned physical activity of 30 min/day
- Brisk walking or arm exercises while seated in a chair for 10 min after each meal
- Women physically active prior to pregnancy should be encouraged to continue their

**Fig. 2** Recommendations for physical activity in women with gestational diabetes mellitus

metformin are both pregnancy category B and are considered safe and effective. The use of oral medication is increasing, and in some settings they are the first line when diet fails and pharmacological treatment is required for women with GDM. In a large nationwide retrospective cohort study in the USA, including 10,778 women with drug-treated GDM, the use of glyburide increased from 7.4% in 2000 to 64.5% in 2011, becoming the most common treatment since 2007 (Hunt and Schuller 2007).

**Glyburide:** Glyburide is a second-generation sulfonylurea that binds to pancreatic  $\beta$ -cell adenosine triphosphate calcium channel receptors and increases insulin secretion and insulin sensitivity of peripheral tissues. Its transfer across the placental barrier was first evaluated in single-cotyledon placental models, wherein no significant transfer of glyburide was found, even when maternal glyburide concentrations were much higher than the therapeutic concentrations (Elliott et al. 1991, 1994). Other studies (Kraemer et al. 2006; Nanovskaya et al. 2008) suggested that glyburide may be actively transported from fetus to mother and that the fetus may be exposed to about 9–70% of the maternal concentration. Following these observations, Langer et al. (2000) conducted a pivotal RCT to compare the efficacy and safety of glyburide ( $n = 201$ ) and insulin ( $n = 203$ ) among women with GDM. This study found no differences in the rate of maternal and neonatal adverse outcomes between the glyburide- and insulin-treated groups, as well as no detection of glyburide in cord blood. Furthermore, glycemic control and pregnancy outcomes were comparable. Subsequently, these observations were confirmed in a series of clinical studies evaluating the outcome of infants born to mothers receiving glyburide during the second and third trimesters for GDM (Kremer and Duff 2004; Jacobson et al. 2005; Lain et al. 2009) as well as for T2DM (ADA 2000b).

A few large prospective cohort studies compared glyburide with insulin analyzing both maternal and fetal outcomes (Langer et al. 2000; Lain et al. 2009; Tempe and Mayanglambam 2013; Anjalakshi et al. 2007; Ogunyemi et al. 2007; Mukhopadhyay et al. 2012; Silva et al. 2010, 2012; Moore et al. 2010; Balsells et al. 2015). The smaller cohort studies found no differences in macrosomia or fetal birth weight (Kremer and Duff 2004; Jacobson et al. 2005; Chmait et al. 2004; Conway et al. 2004; Rochon et al. 2006; Kahn et al. 2006; Yogev et al. 2011). Other studies demonstrated that among women treated with glyburide, there were higher rates of NICU admissions for fetal hypoglycemia (Rochon et al. 2006). The glyburide failure rates (meaning there was a need for supplemental insulin or a change to insulin therapy) in these trials ranged from 6% to 20%. A large cohort study, of 10,682 women with GDM, found that glyburide use was associated with significant increases in NICU admissions (OR 1.4 [95% CI, 1.07–2.00]) and macrosomia (OR 1.29 [95% CI, 1.03–1.64]), yet there were no significant differences in birth weights  $>4500$  g or LGA. The glyburide failure rate in this study was 37%. A more recent large cohort study assessed over 100,000 patients diagnosed with GDM in the USA according to insurance claims (Camelo Castillo et al. 2015). A total of 4982 were treated with glyburide and 4191 with insulin. Patients taking glyburide were associated with significantly more NICU admissions (RR 1.41 [95% CI, 1.23–162]), episodes of respiratory distress (RR 1.63 [95% CI, 1.23–2.15]), and LGA births (RR 1.43 [95% CI, 1.16–1.76]). There were no significant differences in



**Table 8** Patient considerations for oral medication therapies in GDM patients

Drug	Optimal candidate	Characteristics that are more likely to require supplemental insulin
Glyburide	Fasting OGTT <110 mg/dL Gestational age at time of treatment >25 weeks Singleton No previous history of GDM Younger maternal age	Fasting OGTT >110 mg/dL Gestational age at time of treatment <25 weeks Multiparous Previous history of GDM Older maternal age
Metformin	Fasting OGTT <100 mg/dL Later gestational age at time of treatment No previous history of GDM Lower BMI	Fasting OGTT >110 mg/dL Earlier gestational age at time of treatment Previous history of GDM BMI>35

OGTT, oral glucose tolerance test; BMI, body mass index

neonatal hypoglycemia rates, birth trauma, preterm births, jaundice, or Cesarean delivery rates, respectively.

Another meta-analysis studied 7 RCTs comparing glyburide with insulin in a total of 798 patients (Balsells et al. 2015). The glyburide group had significantly higher mean birth weight (with a mean difference 109 g [95% CI, 35.9–181]), macrosomia (RR 2.62 [95% CI, 1.35–5.08]), and neonatal hypoglycemia (RR 2.04 [95% CI, 1.30–3.20]) compared with insulin therapy. The failure rate with glyburide in this meta-analysis was 6.37%.

Previous studies tried to assess the ideal patient characteristics for glyburide treatment (Table 8). Given that failure rates range from as low as 6% to as high as 37%, ideal candidates for trial of glyburide are women with lower fasting OGTT levels at screening, women further along in their pregnancy ( $\geq 25$  weeks gestation) at the time of treatment, and women who have a singleton pregnancy (Chmait et al. 2004; Rochon et al. 2006; Yogev et al. 2011; Cheng et al. 2012).

**Metformin:** Metformin is a biguanide that inhibits hepatic gluconeogenesis and glucose absorption and stimulates glucose uptake in peripheral tissues. Metformin has been shown to freely cross the placental barrier (Charles et al. 2006), reaching concentrations in fetal circulation of 50% or more of those measured in maternal serum (Eyal et al. 2010). Several studies provide reassuring safety for metformin, mainly among women with PCOS, who were exposed to metformin prior and at the time of conception, ongoing with treatment at pregnancy (Gilbert et al. 2006; Zhuo et al. 2014). In the Metformin in Gestational Diabetes (MiG) trial, which was the largest RCT comparing metformin with insulin, Rowan et al. (2008) randomized 751 women with GDM at 20–33 weeks to treatment with either metformin or insulin. Compared to insulin, metformin was associated with lower rates of neonatal hypoglycemia (3.3% vs. 8.1%;  $P < 0.008$ ), but with a higher rate of preterm birth (12.1% vs. 7.6%;  $P = 0.04$ ), and no difference in other maternal and neonatal adverse events. In the 2-year follow-up of the MiG trial, offspring of mothers treated with metformin had more upper body subcutaneous fat (Offspring and Tofu 2011). A 1-year follow-up of women and offspring from an RCT of

women, with PCOS treated with or without metformin during pregnancy (Carlsen et al. 2012), found that although women in the metformin group gained less weight during pregnancy, they had a higher BMI 1-year postpartum and that the offspring in the metformin group were significantly heavier (0.5 kg) at 1 year of age. Another similar but smaller study from the same authors found significantly higher fasting glucose in an 8-year-old offspring of women treated with metformin (Rø et al. 2012). In a meta-analysis of ten studies that assessed the effect of exposure to metformin, the rate of congenital anomalies and neonatal mortality was not increased (Li et al. 2015). A prospective study of 126 infants of mothers treated with metformin for PCOS during pregnancy reported no adverse effects on the infants' weight, length, motor activity, or behavior at the age of 18 months (Glueck and Wang 2007). In the MiG trial (Rowan et al. 2008), the rate of composite neonatal morbidity (neonatal hypoglycemia, respiratory distress, need for phototherapy, birth trauma, 5-min Apgar score <7, or prematurity) was comparable in the metformin and the insulin groups. In addition, there were no differences in the degree of glycemic control and in umbilical cord insulin levels between the metformin and insulin groups, respectively. Metformin was associated with a lower weight gain during pregnancy (0.4 +/- 2.9 vs. 2 +/- 3.3 kg;  $P < 0.001$ ). Furthermore, the majority of women in the metformin group stated that they would choose to receive their assigned treatment again (76.6% vs. 27.2%;  $P < 0.001$ ). Nevertheless, metformin was associated with a failure rate of 46.3%.

Moore et al. (2010) assigned 149 women with GDM, who had failed diet treatment to either metformin or glyburide. The failure rate in achieving adequate glycemic control in the metformin group was 34.7%, which was more than twofold higher than in the glyburide group (16.2%;  $P = 0.01$ ). In another recent RCT (Silva et al. 2010), 72 women with GDM were randomized for treatment with metformin or glyburide; the failure rate of metformin and glyburide was 25% and 23.8%, respectively.

In conclusion, the ideal candidates for metformin treatment are women with PCOS, who have lower body mass index (BMI) and lower fasting OGTT levels at screening as well as those who are further along in their pregnancy at the time of treatment and experiencing a first episode of gestational diabetes (Table 8) (Rowan et al. 2008; Terti et al. 2008; Ijäs et al. 2011).

**Insulin:** When blood glucose targets cannot be reached by diet and/or by oral antidiabetic drugs, insulin is required. There is no evidence supporting the advantages of any one type of insulin or regimen of insulin over another. Thus, insulin type and regimens should be individualized (ADA 2004; Buchanan et al. 1998; Pertot et al. 2011; Di Cianni et al. 2008). It is beneficial to pair rapid-acting with intermediate-/long-acting insulin, in order to simulate the physiologic insulin secretion throughout the day. In women with diabetes, insulin requirements gradually increase throughout pregnancy: 0.7 units/kg/day in the first trimester, 0.8 units/kg/day from week 18, 0.9 units/kg/day from week 26, and 1.0 units/kg/day from week 36 until delivery. Insulin does not cross the placenta (ACOG 2013) and is considered category B for all insulins (except glulisine and glargine), that is why many guidelines continue to recommend insulin as the first-line therapy. Insulin regimens are divided into three categories: short-acting (lispro and aspart), intermediate-acting (neutral protamine Hagedorn [NPH]), and long-acting analogs (detemir and

**Table 9** Insulin action profile

Insulin type	Onset of action	Peak of action	Duration of action (h)
Lispro	1–15 min	1–2 h	4–5
Aspart	1–15 min	1–2 h	4–5
Regular	30–60 min	2–4 h	6–8
NPH	1–3 h	5–7 h	13–18
Glargine	1 h	No peak	24

glargine). Although NPH is considered as an intermediate-acting insulin (Langer et al. 1988), its basal insulin action in pregnant women may require two to three daily injections. Consequently, the risk of hypoglycemia is increased, particularly at night. These disadvantages in human insulin can be overcome by the use of short-acting and long-acting insulin analogs or continuous insulin infusion in a pump (Hod et al. 2015). Insulin action profile is represented in Table 9.

**Aspart:** Pettitt et al. (2003) were the first to compare the efficacy of insulin aspart with that of regular human insulin in 15 women with GDM, demonstrating improved glycemic control with insulin aspart. The Insulin Aspart Pregnancy Study Group conducted the largest evaluation to date of insulin aspart use in pregnancy. A total of 322 women with T1DM were randomized to receive either insulin aspart or regular insulin. The rates of major congenital malformations (Hod et al. 2008), maternal and cord blood levels of insulin antibodies (McCance et al. 2008), hypoglycemic events, and pregnancy outcomes were comparable, while glycemic control was improved in the group receiving insulin aspart (Mathiesen et al. 2007). Safety meta-analysis, published in 2015, included 6 RCTs, comparing aspart ( $n = 567$ ) to regular insulin ( $n = 516$ ) (Lv et al. 2015). Rates of Cesarean deliveries and macrosomia were similar in pregnant women treated with aspart and regular insulin (Hod et al. 2008; Lv et al. 2015). Another study comparing aspart with regular insulin found controlled HbA1c during pregnancy and postpartum in both groups. However, 30 and 60 min after a meal, aspart group had lower mean glucose concentration. Hypoglycemia occurred in both groups (aspart  $n = 10$ , regular insulin  $n = 9$ ). No difference was found between fetal weights and cases of macrosomia (Pettitt et al. 2007).

**Lispro:** Former reports suggested congenital anomalies related to the use of lispro during pregnancy (Diamond and Kormas 1997). However, this association was probably due to poor glycemic control rather than drug-induced teratogenesis (Chitayat et al. 2009). Four retrospective analyses of women with pregestational diabetes treated with lispro during pregnancy found no difference between the rates of congenital malformations, preterm delivery, and birth weight when compared with regular insulin (Scherbaum et al. 2002; Masson et al. 2003; Wyatt et al. 2005; Persson et al. 2002). A retrospective cohort study of 538 pregnant women with GDM compared lispro treatment to regular insulin (Bhattacharyya et al. 2001). The incidence of congenital abnormalities between groups was not significant. Lower A1Cs were noted in lispro patients compared with patients taking regular insulin (5.8 vs. 6.08%,  $p < 0.05$ ). Another RCT comparing lispro to regular insulin (Mecacci

et al. 2003) found maternal glucose levels to be significantly lower at 1 h after eating (lispro 108.4 mg/dL vs. regular 121.0 mg/dL,  $p < 0.01$ ). A review published in 2010 included 27 publications of 1265 pregnancies, comparing lispro to regular insulin during pregnancy (Edson et al. 2010). Lispro was associated with lower postprandial glucose and A1c levels. No significant difference between spontaneous abortion and congenital anomalies (Edson et al. 2010). In 2015, a meta-analysis studied the safety of different insulin analogs (Lv et al. 2015). This meta-analysis included 9 observational studies comparing lispro ( $n = 452$ ) to regular insulin ( $n = 1089$ ). There were differences in neonatal outcomes: decreased incidence of jaundice [RR 0.63; 95% CI, 0.44–0.90], higher incidence of LGA [RR 1.42; 95% CI, 1.20–1.69], and higher birth weight [weighted mean differences (WMD) = 116.44; 95% CI, 28.78–204.11] at the lispro group. Patient treated with lispro had no increased risk for Cesarean delivery, congenital malformations, macrosomia, neonatal hypoglycemia, NICU admissions, respiratory distress syndrome (RDS), or stillbirth, respectively. This and more, lispro patients showed decreased risk of severe maternal hypoglycemia (RR 0.33; 95% CI, 0.12–0.89) compared with regular insulin (Lv et al. 2015).

**NPH:** Neutral protamine Hagedorn (NPH) insulin has an 8-h duration. Thus, it is an intermediate-acting insulin. A basal insulin action in a pregnant woman can be attained by three injections of NPH. However, the risk of hypoglycemia is increased, particularly at night, due to an insulin peak in the NPH profile. Currently, the best basal insulin action can be achieved by using insulin detemir or insulin aspart/lispro as a constant infusion in an insulin pump (Langer et al. 1988; Mathiesen et al. 2012).

**Detemir:** Two insulin analogs have a prolonged basal activity: insulins detemir and glargine. They function as basal, non-meal-related insulin release during the day. Only detemir was studied before and during pregnancy in a large randomized controlled trial in patients with type 1 diabetes (Mathiesen et al. 2012). Treatment with detemir resulted in non-inferior HbA1c in late gestation and similar maternal hypoglycemia rates compared with NPH insulin. In addition, perinatal morbidity and mortality were comparable, and no specific safety issues were identified (Hod et al. 2014).

**Glargine:** However, several retrospective analyses have demonstrated that glargine might also be safe in pregnancy (Callesen et al. 2013; Lepercq et al. 2012; Pollex et al. 2011). Indeed, results from a transplacental transfer study showed that insulin glargine has not crossed the placenta at therapeutic concentrations (Pollex et al. 2010).

**Subcutaneous continuous insulin infusion (CSII):** CSII is an alternative treatment to multiple daily injections (MDI) for people with type 1 diabetes mellitus (T1DM). The new and modern pumps are smaller, more efficacious, easier to use, and safe. However, no clear difference between CSII and MDI has been established for the treatment in pregnant women with T1DM. Rather, both treatments are safe and valid during pregnancy (González-Romero et al. 2010). Nevertheless, CSII treatment improves patients' satisfaction and lifestyle flexibility as compared to MDI.

**Continuous glucose monitoring system (CGMS):** As previously mentioned, CGMS during the second half of pregnancy was characterized enabling the definition of normal glycemia. Next, the time interval from meal to peak postprandial glucose levels was evaluated. Whereas in nondiabetic pregnancy, the interval was 70 min, it

was somewhat later, ~90 min, in gestations complicated by diabetes (Ben-Haroush et al. 2004). In addition, the peak glucose values were  $103 \pm 26$  mg/dL and  $164 \pm 53$  mg/dL in patients with well-controlled and poorly controlled diabetes, respectively. Taking into account the glycemic targets currently recommended for diabetes in pregnancy (140 mg/dL at 1 h and 120 mg/dL at 2 h), it was suggested by Chitayat et al. (2009) that blood glucose determinations should be taken at 90 min post-meal with a desired glucose value of ~110 mg/dL. Importantly, this suggested glucose target should be further tested for its correlation to pregnancy outcomes.

CGM was studied for several aspects of diabetes treatment in pregnancy. First, using CGM for treatment assessment, it was shown that undetected hyperglycemia and asymptomatic hypoglycemic events are common during pharmacological treatment in GDM (Chen et al. 2003; Yogeve et al. 2004b). Second, “blinded” CGM for 72 h was used for adjustment of therapy in pregnant women with T1DM (Kerssen et al. 2004). It was concluded that this CGM method is not advisable as there is a wide variability in the day-to-day glucose levels of T1DM pregnancies. Hence, real-time CGM use could possibly overcome this limitation. Consequently, a study was designed with a sample size large enough to provide data on pregnancy outcome in T1DM using real-time CGM. This Continuous Glucose Monitoring in Women with Type 1 Diabetes in Pregnancy Trial (CONCEPTT) study in pregnant women or women planning pregnancy is ready to be launched in the following year.

Future technological development consists of an artificial pancreas, based on a “closed-loop” system, i.e., delivering insulin and/or glucagon/glucose, sensing glucose, and controlling delivery according to blood glucose levels (Chitayat et al. 2009). However, the accuracy of the current CGM and algorithms is not yet sufficient to permit the loop to be closed. Thus, research direction should include the improvement of CGM and insulin algorithms. Implementation of an artificial pancreas for diabetes in pregnancy will hopefully lead to a perinatal outcome similar to nondiabetic subjects.

**Timing and mode of delivery:** The optimal time to deliver the infant of a diabetic mother is a delicate balance between the perceived risk of stillbirth and shoulder dystocia and the consequences of unnecessary prematurity, failed induction, and Cesarean delivery. The indications for planned delivery of a patient with diabetes include macrosomia or large-for-gestational-age fetus, previous stillbirth, prevention of fetal demise, and reduction in potential shoulder dystocia. Maternal indications for planned delivery include hypertension, diabetic vasculopathy, and poor compliance to the diabetic management resulting in adverse glycemic control (Hod and Yogeve 2010). When diabetes is well controlled and gestational age is well documented, respiratory distress syndrome at or beyond 39 weeks of gestation is rare enough that routine amniocentesis for pulmonary maturity is not necessary. At earlier gestational ages, or when control is poor or undocumented, pulmonary maturity should be assessed before induction. However, when early delivery is planned because of maternal or fetal compromise, the urgency of the indication should be considered in the decision to perform amniocentesis.

**Cesarean delivery:** There is no consensus regarding the estimated fetal weight in which Cesarean delivery is recommended to avoid Erb’s palsy or other

complications; most studies range between 4000 and 4500 g. Langer et al. (1991) demonstrated the rate of Erb's palsy among macrosomic babies of diabetic mothers is 3.2% versus 0.3% among nondiabetics. Ecker et al. (1997) found that the risk for brachial plexus injury is 3.19 times greater in diabetic women and is 10 times higher when birth weight is over 4000 g and 18 times higher over 4500 g. Conway (2002) suggested the limit of 4250 g for Cesarean section in diabetic mothers. They found 50% reduction in the incidence of shoulder dystocia (1.1% vs. 2.4%), along with an increase in the Cesarean section rate (25.1% vs. 21.7%,  $p < 0.04$ ).

Several studies have tried to evaluate the number of elective Cesarean deliveries needed for diabetic mothers in order to avoid a case of one neonate born with arm paralysis due to brachial plexus injury during delivery (Erb's palsy). Rouse and Owen (1999) calculated the probability of shoulder dystocia based on birth weight in diabetic and nondiabetic pregnancies. For birth weights of 4500 g or more, there was a 52% probability in diabetic compared to 14% in nondiabetic pregnancies, and the mean probability that a neonatal brachial plexus injury would persist was 6.7% (range 0–19%). Thus, to prevent one neonate with permanent arm palsy injury in babies weighing 4500 g or more would necessitate performing 153 Cesarean deliveries in diabetic mothers and 419 in nondiabetic mothers. If a cutoff of 4000 g is used, then 169 Cesarean sections would be required in diabetic women compared to 654 in nondiabetic women. Ecker et al. (1997) calculated NNT of 219 to 962 Cesareans for an estimated birth weight  $\geq 4000$  g and 91 to 400 cesareans for an estimated birth weight  $\geq 4500$  g. ACOG recommends Cesarean section when estimated fetal weight is over 4500 g in diabetic mothers (ACOG 2013).

Although Erb's palsy is a severe complication, bone fractures, asphyxia, respiratory complications requiring neonatal intensive care unit admission, and neonatal and fetal demise should be considered when calculating the cost of Cesarean sections performed to prevent shoulder dystocia and adverse outcome.

**Induction of labor:** The Cochrane database (Conway and Langer 1998) compared a policy of elective induction at 38 weeks to expectant management up to 42 weeks. There was no difference in Cesarean delivery rates between the groups (RR = 0.81; 95% CI 0.52–1.26), the induction group had a lower risk of macrosomia (RR = 0.56; 95% CI 0.32–0.98), and there were 3 cases of mild shoulder dystocia in the expectant management group. A large retrospective cohort study (Levy et al. 2002) conducted in the USA encompassing data for more than 100,000 deliveries found that although women with diabetes had an increased risk of Cesarean delivery compared to women without diabetes (OR 2.00; 95% CI 1.83–2.19), induction of labor was associated with a lower risk of Cesarean delivery compared to those whose labor was not induced (OR = 0.77; 95% CI 0.5–0.89).

**Glucose control during labor and delivery:** Neonatal hypoglycemia develops as a consequence of the heightened fetal insulin response to cope with transplacental transfer of high maternal glucose. After delivery, the sudden decrease in glucose supply to the newborn in the midst of high insulin levels of fetal origin results in hypoglycemia (Group HSCR et al. 2008; Pedersen 1954). Several observational trials have studied the correlation between glucose levels during labor and neonatal

outcomes (Balsells et al. 2000; Andersen et al. 1985; Miodovnik et al. 1987; Curet et al. 1997; Lean et al. 1990; Feldberg et al. 1988). There is a general agreement that maternal hyperglycemia during labor and delivery is associated with neonatal hypoglycemia, in both, GDM and T2DM. Other reports show that maternal hyperglycemia during labor is also associated with birth asphyxia and nonreassuring fetal heart rate tracings (Feldberg et al. 1988; Mimouni et al. 1988). In women with type 1 diabetes (T1DM), it has been shown that targeting maternal glucose levels in the range of 72–126 mg/dL (4.0–7.0 mmol/L) during labor is associated with a lower risk of maternal hypoglycemia than lower target levels (Carron-Brown et al. 1999). In addition, these levels during labor and delivery are helpful in reducing the incidence of neonatal hypoglycemia, birth asphyxia, and nonreassuring heart rate tracings.

---

## Postpartum Management

The postpartum period is crucial, not only in terms of addressing the immediate perinatal problems but also in the long term for establishing the basis for early preventive health for both, mother and child, who are at a heightened risk for future obesity, metabolic syndrome, diabetes, hypertension, and cardiovascular disorders.

**Infections:** Mothers with diabetes have an increased risk of infection and thus, require extra attention in order to detect early signs of genitourinary, uterine, and surgical site infections (episiotomy and Cesarean delivery), particularly if the delivery has been prolonged or required operative intervention. The large-sized offspring of diabetic mothers do not suckle well; this may lead to milk retention and higher risk of breast abscess. Apart from neonates with infant respiratory distress syndrome or those with aspiration during birth, the risk of infection in the offspring of diabetic mothers is no higher than in the offspring of nondiabetic women (Linder et al. 2014).

**Breastfeeding:** Mothers with GDM and diabetes in pregnancy should be encouraged and supported in initiating and maintaining breastfeeding. Breastfeeding has been shown to be protective against the occurrence of infant and maternal complications (Mayer-Davis et al. 2006), including reduction in childhood obesity, T2DM, and even T1DM (O'Reilly et al. 2012; Owen et al. 2006; Gunderson 2007; Plagemann et al. 2002). Moreover, breastfeeding helps postpartum weight loss. Treatment with insulin, glyburide, or metformin is not a contraindication to breastfeeding as levels of medication transfer to breast milk are negligible and do not cause hypoglycemia in the baby.

**Contraception:** Women with GDM and diabetes should be encouraged to space their pregnancies in order to maintain and achieve optimal health between pregnancies. This also helps reduce the risk of GDM or diabetes in a subsequent pregnancy. In women with diabetes, pregnancy planning helps ensure that conception can occur when the mother's metabolic health is optimal to reduce risks of spontaneous abortions or congenital malformations. These women must have access to and should receive advice about safe and effective methods of contraception (Skouby et al. 1991; Beydoun et al. 2009). With advances in contraceptive technology,

clinicians can now offer their patients a relatively large range of options ensuring efficacy, efficiency, and satisfaction with regard to individual preferences.

**Postpartum glucose testing:** For all women diagnosed with hyperglycemia for the first time during pregnancy (GDM and diabetes in pregnancy), the glycemic status should be reevaluated with a 75 g oral OGTT at 6–12 weeks after delivery (Metzger et al. 2007; ADA 2011). Diagnosis at that time should be based on the currently recommended WHO criteria for diabetes (Group WGD 2013), impaired fasting glucose (IFG), and impaired glucose tolerance (IGT) in the nonpregnant state. Women who do not have diabetes or prediabetes, according to these definitions, are still at risk of progression to diabetes and other cardiovascular problems and require ongoing surveillance (ADA 2011) according to local protocol. There is no clear guidance about the type of tests (should these women undergo annual OGTTs, or can fasting plasma glucose or HbA1c measurement suffice?) or the frequency, and duration for ongoing surveillance. When guidance exists it is often glucose centric, missing out other important parameters, but most importantly, it is poorly implemented.

**Reducing long-term risk of T2DM and cardiovascular disease:** Women with GDM have the same or a higher level of future risk of diabetes and cardiovascular disease as people with prediabetes, and they should be advised to maintain a healthy lifestyle with an appropriate diet, regular exercise, and normal body weight. Furthermore, to ensure optimal health before attempting their next pregnancy, they should seek consultation with healthcare providers, knowledgeable about diabetes prevention, prior to the discontinuation of contraception.

The onset of postpartum type 2 diabetes is observed within 5–10 years. The rate is reported from 2.6% to 70%, from 6 weeks to 28 years postpartum (Kim et al. 2002). A multitude of studies reported various risk factors that may predict postpartum diabetes, including ethnicity, fasting glucose values at OGTT and during pregnancy, postpartum fasting glucose, insulin use during pregnancy, maternal age, weight, body mass index, HbA1c, previous history of gestational diabetes, family history of diabetes, and parity (Kim et al. 2002; Järvelä et al. 2006). Recurrence rates for gestational diabetes are 30–84%. Therefore, in women with previous GDM, planning future pregnancies should be consulted appropriately prior to their following pregnancy.

Both, “intensive lifestyle” and metformin, have been shown to be highly effective in delaying or preventing diabetes in women with IGT and a history of GDM (Ratner et al. 2008). Data from the Diabetes Prevention Program Outcomes Study (DPPOS) have been published (Aroda et al. 2015) and show that the benefits of lifestyle intervention and metformin seen in the DPP study continue over a longer period. DPPOS is a long-term follow-up of the DPP participants to investigate whether the delay in the development of diabetes observed during DPP is sustained and to assess the long-term effects of the interventions on health. DPPOS followed participants from the DPP study for an additional 7 years, during which time, the lifestyle and metformin groups were encouraged to continue those interventions, and all participants were offered group lifestyle classes. Over 10 years, women with history of GDM assigned to placebo, had a 48% higher risk of developing overt diabetes compared with women without a history of GDM. In women with a history of



GDM, “intensive lifestyle” and metformin-reduced progression to diabetes compared with placebo by 35% and 40%, respectively. Among women without a history of GDM, “intensive lifestyle” reduced the progression to diabetes by 30%, while metformin did not reduce the progression to diabetes (Aroda et al. 2015).

As part of the ongoing Diabetes and Women’s Health Study, a cohort of 4554 women from the Nurses’ Health Study II who had a history of GDM were followed up from 1991 to 2007. Compared with women who maintained their total physical activity levels, women who increased their total physical activity levels by 7.5 MET-h/week or more (equivalent to 150 min per week of moderate intensity physical activity) had a 47% lower risk of T2DM (RR 0.53; 95% CI, 0.38–0.75); the association remained significant after additional adjustment for BMI (Bao et al. 2014). Increasing physical activity might have lowered the risk of progression from GDM to T2DM.

Postpartum care is a critical area that should not be overlooked because of the long-term and intergenerational consequences. However, there are many barriers to achieving this objective (Nielsen et al. 2014). Following delivery, women with GDM seldom present with diabetes, and they are no longer pregnant, therefore, unlikely to visit physicians or obstetricians for checkups. They are thus, likely to be considered lost to follow-up. However, these women do visit health services focused on the well-being of their babies (for instance, for the child’s vaccination program and to monitor the child’s growth and development) and are likely to do so at regular intervals for at least 5 years (Kapur 2011). Obstetricians, family physicians, internists, pediatricians, and other healthcare providers must link postpartum follow-up of a GDM mother with the child’s vaccination and routine pediatric care program to ensure continued follow-up and engagement of the high-risk mother-child pair.

---

## References

- ACOG. PB137 Gestational diabetes mellitus. *Obstet Gynecol.* 2013;122(2 Pt 1):406–16. <https://doi.org/10.1097/01.AOG.0000433006.09219.f1>
- ACOG technical bulletin. Diabetes and pregnancy. Number 200 – December 1994 (replaces No. 92, May 1986). Committee on Technical Bulletins of the American College of Obstetricians and Gynecologists. *Int J Gynaecol Obstet.* 1995;48(3):331–9. <http://www.ncbi.nlm.nih.gov/pubmed/7781883>
- Agarwal MM. Evolution of screening and diagnostic criteria for GDM worldwide. In: Edition I, Kim C, Ferrara A, editors. *Gestational diabetes during and after pregnancy*. Illustrated edition. London: Springer; 2010. p. 35–48.
- Algert S, Shragg P, Hollingsworth DR. Moderate caloric restriction in obese women with gestational diabetes. *Obstet Gynecol.* 1985;65(4):487–91.
- American College of Obstetricians and Gynecologists. ACOG Committee opinion number 315, September 2005. Obesity in pregnancy. *Obstet Gynecol.* 2005a;106(3):671–5. <https://doi.org/10.1097/AOG.0b013e31822c99af>.
- American College of Obstetricians and Gynecologists. ACOG Committee opinion number 313, September 2005. The importance of preconception care in the continuum of women’s health care. *Obstet Gynecol.* 2005b;106(3):665–6. <http://www.ncbi.nlm.nih.gov/pubmed/16135611>
- American Diabetes Association. Gestational diabetes mellitus. *Diabetes Care.* 2000a;23(Suppl 1): S77–9. <http://www.ncbi.nlm.nih.gov/pubmed/12017686>

- American Diabetes Association. Implications of the United Kingdom prospective diabetes study. *Diabetes Care*. 2000b;23(Suppl 1):S27–31. <http://www.ncbi.nlm.nih.gov/pubmed/12017673>
- American Diabetes Association. Gestational diabetes mellitus. *Diabetes Care*. 2004;27(Suppl 1):S88–90. <http://www.ncbi.nlm.nih.gov/pubmed/14693936>
- American Diabetes Association. Standards of medical care in diabetes. *Diabetes Care*. 2005;28(1):S4–S36. <https://doi.org/10.2337/dc10-S011>.
- American Diabetes Association. Standards of medical care in diabetes – 2011. *Diabetes Care*. 2011;34(Suppl. 1):S11–61. <https://doi.org/10.2337/dc11-S011>.
- American Diabetes Association. Standards of medical care in diabetes – 2012. *Diabetes Care*. 2012;35(Suppl. 1):1–94. <https://doi.org/10.2337/dc12-s011>.
- American Diabetes Association. Standards of medical care in diabetes – 2013. *Diabetes Care*. 2013;36(Suppl 1):S11–66. <https://doi.org/10.2337/dc13-S011>.
- American Diabetes Association. Standards of medical care in diabetes – 2015. *Diabetes Care*. 2015;38(January):S1–S93. <https://doi.org/10.2337/dc12-s011>.
- Andersen O, Hertel J, Schmolker L, Kühl C. Influence of the maternal plasma glucose concentration at delivery on the risk of hypoglycaemia in infants of insulin-dependent diabetic mothers. *Acta Paediatr Scand*. 1985;74(2):268–73. <http://www.ncbi.nlm.nih.gov/pubmed/3993374>
- Anjalakshi C, Balaji V, Balaji MS, Seshiah V. A prospective study comparing insulin and glibenclamide in gestational diabetes mellitus in Asian Indian women. *Diabetes Res Clin Pract*. 2007;76(3):474–5. <https://doi.org/10.1016/j.diabres.2006.09.031>.
- Aroda VR, Christophi CA, Edelstein SL, et al. The effect of lifestyle intervention and metformin on preventing or delaying diabetes among women with and without gestational diabetes: the diabetes prevention program outcomes study 10-year follow-up. *J Clin Endocrinol Metab*. 2015;100(4):1646–53. <https://doi.org/10.1210/jc.2014-3761>.
- Artal R, Catanzaro RB, Gavard JA, Mostello DJ, Friganza JC. A lifestyle intervention of weight-gain restriction: diet and exercise in obese women with gestational diabetes mellitus. *Appl Physiol Nutr Metab*. 2007;32(3):596–601. <https://doi.org/10.1139/H07-024>.
- Avery MD, Walker AJ. Acute effect of exercise on blood glucose and insulin levels in women with gestational diabetes. *J Matern Fetal Med*. 2001;10(1):52–8.
- Balsells M, Corcoy R, Adelantado JM, Garcia-Patterson A, Altirriba O, de Leiva A. Gestational diabetes mellitus: metabolic control during labour. *Diab Nutr Metab*. 2000;13(5):257–62.
- Balsells M, García-Patterson A, Solà I, Roqué M, Gich I, Corcoy R. Glibenclamide, metformin, and insulin for the treatment of gestational diabetes: a systematic review and meta-analysis. *BMJ*. 2015;350(jan21\_14):h102. <https://doi.org/10.1136/bmj.h102>.
- Bao W, Tobias K, Bowers K, et al. Physical activity and sedentary behaviors associated with risk of progression from gestational diabetes mellitus to type 2 diabetes mellitus: a prospective cohort study. *JAMA Intern Med*. 2014;174(7):1047.
- Ben-Haroush A, Yogev Y, Chen R, Rosenn B, Hod M, Langer O. The postprandial glucose profile in the diabetic pregnancy. *Am J Obstet Gynecol*. 2004;191(2):576–81. <https://doi.org/10.1016/j.ajog.2004.01.055>.
- Beydoun HA, Beydoun MA, Tamim H. How does gestational diabetes affect postpartum contraception in nondiabetic primiparous women? *Contraception*. 2009;79(4):290–6. <https://doi.org/10.1016/j.contraception.2008.10.013>.
- Bhattacharyya A, Brown S, Hughes S, Vice PA. Insulin lispro and regular insulin in pregnancy. *QJM*. 2001;94(5):255–60.
- Buchanan TA, Kjos SL, Schafer U, et al. Utility of fetal measurements in the management of gestational diabetes mellitus. *Diabetes Care*. 1998;21:B99.
- Callesen NF, Damm J, Mathiesen JM, Ringholm L, Damm P, Mathiesen ER. Treatment with the long-acting insulin analogues detemir or glargine during pregnancy in women with type 1 diabetes: comparison of glycaemic control and pregnancy outcome. *J Matern Neonatal Fetal Med*. 2013;26(6):588–92. <https://doi.org/10.3109/14767058.2012.743523>.
- Camelo Castillo W, Boggess K, Stürmer T, Brookhart MA, Benjamin DK, Jonsson Funk M. Association of adverse pregnancy outcomes with glyburide vs insulin in women with gestational diabetes. *JAMA Pediatr*. 2015;169(5):452–8. <https://doi.org/10.1001/jamapediatrics.2015.74>.

- Carlsen SM, Martinussen MP, Metformin's VE. Effect on first-year weight gain: a follow-up study. *Pediatrics*. 2012;130:e1222–6. <https://doi.org/10.1542/peds.2012-0346>.
- Carpenter MW, Coustan DR. Criteria for screening tests for gestational diabetes. *Am J Obstet Gynecol*. 1982;144:768–73. 0002-9378(82)90349-0 [pii]
- Carrapato MR, Marcelino F. The infant of the diabetic mother: the critical developmental windows. *Early Pregnancy*. 2001;5(1):57–8.
- Carron-Brown S, Kyne-Grzebalski D, Mwangi B, et al. Effect of management policy upon 120 type 1 diabetic pregnancies: policy decisions in practice. *Diabet Med*. 1999;16(7):573–8.
- Catalano PM, Mele L, Landon MB, et al. Inadequate weight gain in overweight and obese pregnant women: what is the effect on fetal growth? *Am J Obstet Gynecol*. 2014;211(2). <https://doi.org/10.1016/j.ajog.2014.02.004>.
- Charles B, Norris R, Xiao X, Hague W. Population pharmacokinetics of metformin in late pregnancy. *Ther Drug Monit*. 2006;28(1):67–72. 00007691-200602000-00015 [pii]
- Chatfield J. ACOG issues guidelines on fetal macrosomia. *American College of Obstetricians and Gynecologists*. *Am Fam Physician*. 2001;64(1):169–70. <http://www.ncbi.nlm.nih.gov/pubmed/11456432>
- Chen R, Yogev Y, Ben-Haroush A, et al. Continuous glucose monitoring for the evaluation and improved control of gestational diabetes mellitus. *J Matern Fetal Neonatal Med*. 2003;14(4):256–60.
- Cheng YW, Chung JH, Block-Kurbisch I, Inturrisi M, Caughey AB. Treatment of gestational diabetes mellitus: glyburide compared to subcutaneous insulin therapy and associated perinatal outcomes. *J Matern Fetal Neonatal Med*. 2012;25(4):379–84. <https://doi.org/10.3109/14767058.2011.580402>.
- Chitayat L, Jovanovic L, Hod M. New modalities in the treatment of pregnancies complicated by diabetes: drugs and devices. *Semin Fetal Neonatal Med*. 2009;14(2):72–6. <https://doi.org/10.1016/j.siny.2008.09.001>.
- Chmait R, Dinise T, Moore T. Prospective observational study to establish predictors of glyburide success in women with gestational diabetes mellitus. *J Perinatol*. 2004;24(10):617–22. <https://doi.org/10.1038/sj.jp.7211147>.
- Coetzee EJ, Jackson WP. Oral hypoglycaemics in the first trimester and fetal outcome. *S Afr Med J*. 1984;65(16):635–7.
- Conway DL. Choosing route of delivery for the macrosomic infant of a diabetic mother: cesarean section versus vaginal delivery. *J Matern Fetal Neonatal Med*. 2002;12(6):442–8. <https://doi.org/10.1080/jmf.12.6.442.448>.
- Conway DL, Langer O. Elective delivery of infants with macrosomia in diabetic women: reduced shoulder dystocia versus increased cesarean deliveries. *Am J Obstet Gynecol*. 1998;178(5):922–5. [https://doi.org/10.1016/S0002-9378\(98\)70524-1](https://doi.org/10.1016/S0002-9378(98)70524-1).
- Conway DL, Gonzales O, Skiver D. Use of glyburide for the treatment of gestational diabetes: the San Antonio experience. *J Matern Neonatal Fetal Med*. 2004;15(1):51–5. <https://doi.org/10.1080/14767050310001650725>.
- Cox M, Whittle MJ, Byrne A, Kingdom JC, Ryan G. Prepregnancy counselling: experience from 1,075 cases. *Br J Obstet Gynaecol*. 1992;99(11):873–6. <http://www.ncbi.nlm.nih.gov/pubmed/1450133>
- Crowther CA, Hiller JE, Moss JR, McPhee AJ, Jeffries WS, Robinson JS. Effect of treatment of gestational diabetes mellitus on pregnancy outcomes. *N Engl J Med*. 2005;352(24):2477–86. <https://doi.org/10.1056/NEJMoa042973>.
- Curet LB, Izquierdo LA, Gilson GJ, Schneider JM, Perelman R, Converse J. Relative effects of antepartum and intrapartum maternal blood glucose levels on incidence of neonatal hypoglycemia. *J Perinatol*. 1997;17(2):113–5. <http://www.ncbi.nlm.nih.gov/pubmed/9134508>
- De Luca AKC, Nakazawa CY, Azevedo BC, Rudge MVC, De Araújo Costa RA, Calderon IMP. Influence of glycemic control on fetal lung maturity in gestations affected by diabetes or mild hyperglycemia. *Acta Obstet Gynecol Scand*. 2009;88(9):1036–40. <https://doi.org/10.1080/00016340903118018>.
- Denno KM, Sadler TW. Effects of the biguanide class of oral hypoglycemic agents on mouse embryogenesis. *Teratology*. 1994;49(4):260–6. <https://doi.org/10.1002/tera.1420490405>.
- Di Cianni G, Torlone E, Lencioni C, et al. Perinatal outcomes associated with the use of glargine during pregnancy. *Diabet Med*. 2008;25(8):993–6. <https://doi.org/10.1111/j.1464-5491.2008.02485.x>.

- Diamond T, Kormas N. Possible adverse fetal effect of insulin lispro. *N Engl J Med.* 1997;337(14):1009. <https://doi.org/10.1056/NEJM199710023371414>; author reply 1010.
- Ecker JL, Greenberg JA, Norwitz ER, Nadel AS, Repke JT. Birth weight as a predictor of brachial plexus injury. *Obstet Gynecol.* 1997;89(5 Pt 1):643–7.
- Edson EJ, Bracco OL, Vambergue A, Koivisto V. Managing diabetes during pregnancy with insulin lispro: a safe alternative to human insulin. *Endocr Pract.* 2010;16(6):1020–7. <https://doi.org/10.4158/EP10003.RA>.
- Elliott BD, Langer O, Schenker S, Johnson RF. Insignificant transfer of glyburide occurs across the human placenta. *Am J Obstet Gynecol.* 1991;165(4 PART 1):807–12. [https://doi.org/10.1016/0002-9378\(91\)90421-M](https://doi.org/10.1016/0002-9378(91)90421-M).
- Elliott BD, Schenker S, Langer O, Johnson R, Prihoda T. Comparative placental transport of oral hypoglycemic agents in humans: a model of human placental drug transfer. *Am J Obstet Gynecol.* 1994;171(3):653–60. [https://doi.org/10.1016/0002-9378\(94\)90078-7](https://doi.org/10.1016/0002-9378(94)90078-7).
- Eyal S, Easterling TR, Carr D, et al. Pharmacokinetics of metformin during pregnancy. *Drug Metab Dispos.* 2010;38(5):833–40. <https://doi.org/10.1124/dmd.109.031245>.
- Fallis A. Williams textbook of endocrinology; 2016. 13th Edition. Shlomo Melmed Kenneth Polonsky P. Reed Larsen Henry Kronenberg Elsevier, Philadelphia. <https://doi.org/10.1017/CBO9781107415324.004>.
- Farquhar JW, Isles TE. Hypoglycemia in newborn infants of normal and diabetic mothers. *S Afr Med J.* 1968;42(10):237–45. <http://www.ncbi.nlm.nih.gov/pubmed/5652940>
- Feldberg D, Dicker D, Samuel N, Peleg D, Karp M, Goldman JA. Intrapartum management of insulin-dependent diabetes mellitus (IDDM) gestants. A comparative study of constant intravenous insulin infusion and continuous subcutaneous insulin infusion pump (CSII). *Acta Obstet Gynecol Scand.* 1988;67(4):333–8.
- Force USPST. Screening for gestational diabetes mellitus: U.S. Preventive Services Task Force recommendation statement. *Ann Intern Med.* 2008;148:759–65. [Summary for patients in *Ann Intern Med.* 2008;148(10):I60; PMID: 18490671]
- Foyett JP. Management of obesity. *Prim Care Rep.* 2000;6:19.
- Freinkel N. Banting lecture 1980. Of pregnancy and progeny. *Diabetes.* 1980;29(12):1023–35. <https://doi.org/10.2337/diabetes.29.12.1023>.
- Frey KA. Preconception care by the nonobstetrical provider. *Mayo Clin Proc.* 2002;77(5):469–73. <https://doi.org/10.4065/77.5.469>.
- Gilbert C, Valois M, Koren G. Pregnancy outcome after first-trimester exposure to metformin: a meta-analysis. *Fertil Steril.* 2006;86(3):658–63. <https://doi.org/10.1016/j.fertnstert.2006.02.098>.
- Glueck CJ, Wang P. Metformin before and during pregnancy and lactation in polycystic ovary syndrome. *Expert Opin Drug Saf.* 2007;6(2):191–8. <https://doi.org/10.1517/14740338.6.2.191>.
- González-Romero S, González-Molero I, Fernández-Abellán M, et al. Continuous subcutaneous insulin infusion versus multiple daily injections in pregnant women with type 1 diabetes. *Diabetes Technol Ther.* 2010;12(4):263–9. <https://doi.org/10.1089/dia.2009.0140>.
- Group HSCR, Metzger BE, Lowe LP, et al. Hyperglycemia and adverse pregnancy outcomes. *N Engl J Med.* 2008;358(19):1991–2002. <https://doi.org/10.1056/NEJMoa0707943>.
- Group WGD. Diagnostic criteria and classification of hyperglycaemia first detected in pregnancy. *World Health Org.* 2013;1–63. <https://doi.org/10.1016/j.diabres.2013.10.012>.
- Guariguata L, Linnenkamp U, Beagley J, Whiting DR, Cho NH. Global estimates of the prevalence of hyperglycaemia in pregnancy. *Diabetes Res Clin Pract.* 2014;103(2):176–85. <https://doi.org/10.1016/j.diabres.2013.11.003>.
- Gunderson EP. Gestational diabetes and nutritional recommendations. *Curr Diab Rep.* 2004;4(5):377–86. <https://doi.org/10.1007/s11892-004-0041-5>.
- Gunderson EP. Breastfeeding after gestational diabetes pregnancy: subsequent obesity and type 2 diabetes in women and their offspring. *Diabetes Care.* 2007;30(Suppl. 2). <https://doi.org/10.2337/dc07-s210>.
- Hod M, Yogeve Y. Diabetes in pregnancy. In: *Oxford textbook of medicine.* Oxford: Oxford University Press; 2010. p. 2133–9. <https://doi.org/10.1093/med/9780199204854.003.1410>.

- Hod M, Damm P, Kaaja R, et al. Fetal and perinatal outcomes in type 1 diabetes pregnancy: a randomized study comparing insulin aspart with human insulin in 322 subjects. *Am J Obstet Gynecol.* 2008;198(2):186 e1–7. <https://doi.org/10.1016/j.ajog.2007.08.005>. S0002-9378(07)00971-4 [pii]r.
- Hod M, Mathiesen ER, Jovanovic L, et al. A randomized trial comparing perinatal outcomes using insulin detemir or neutral protamine Hagedorn in type 1 diabetes. *J Matern Fetal Neonatal Med.* 2014;27(1):7–13. <https://doi.org/10.3109/14767058.2013.799650>.
- Hod M, Kapur A, Sacks DA, et al. The International Federation of Gynecology and Obstetrics (FIGO) Initiative on gestational diabetes mellitus: a pragmatic guide for diagnosis, management, and care. *Int J Gynecol Obstet.* 2015;131:S173–211. [https://doi.org/10.1016/S0020-7292\(15\)30007-2](https://doi.org/10.1016/S0020-7292(15)30007-2).
- Hunt KJ, Schuller KL. The increasing prevalence of diabetes in pregnancy. *Obstet Gynecol Clin N Am.* 2007;34(2):173–99., vii. <https://doi.org/10.1016/j.ogc.2007.03.002>.
- Ijäs H, Vääräsmäki M, Morin-Papunen L, et al. Metformin should be considered in the treatment of gestational diabetes: a prospective randomised study. *BJOG.* 2011;118(7):880–5. <https://doi.org/10.1111/j.1471-0528.2010.02763.x>.
- International Diabetes Federation (IDF). *IDF diabetes atlas.* 7th ed. Brussels: International Diabetes Federation; 2015. <https://doi.org/10.1289/image.ehp.v119.i03>.
- Jack BW. Preconception care. *JAMA.* 1990;264(9):1147. <https://doi.org/10.1001/jama.1990.03450090083032>.
- Jacobson GF, Ramos GA, Ching JY, Kirby RS, Ferrara A, Field DR. Comparison of glyburide and insulin for the management of gestational diabetes in a large managed care organization. *Am J Obstet Gynecol.* 2005;193(1):118–24. <https://doi.org/10.1016/j.ajog.2005.03.018>.
- Järvelä IY, Juutinen J, Koskela P, et al. Gestational diabetes identifies women at risk for permanent type 1 and type 2 diabetes in fertile age: predictive role of autoantibodies. *Diabetes Care.* 2006;29(3):607–12. <http://www.ncbi.nlm.nih.gov/pubmed/16505514>
- Jensen DM, Damm P, Sørensen B, et al. Clinical impact of mild carbohydrate intolerance in pregnancy: a study of 2904 nondiabetic Danish women with risk factors for gestational diabetes mellitus. *Am J Obstet Gynecol.* 2001;185(2):413–9. <https://doi.org/10.1067/mob.2001.115864>.
- Jiwani A, Marseille E, Lohse N, Damm P, Hod M, Kahn JG. Gestational diabetes mellitus: results from a survey of country prevalence and practices. *J Matern Fetal Neonatal Med.* 2012;25(May 2011):600–10. <https://doi.org/10.3109/14767058.2011.587921>.
- Johns K, Olynik C, Mase R, Kreisman S, Tildesley H. Gestational diabetes mellitus outcome in 394 patients. *J Obstet Gynaecol Can.* 2006;28(2):122–7. [https://doi.org/10.1016/S1701-2163\(16\)32068-0](https://doi.org/10.1016/S1701-2163(16)32068-0).
- Johnson K, Posner SF, Biermann J, et al. Recommendations to improve preconception health and health care – United States. A report of the CDC/ATSDR preconception care work group and the select panel on preconception care. *MMWR Recomm Rep.* 2006;55(RR-6):1–23. <http://www.ncbi.nlm.nih.gov/pubmed/16617292>
- Jones CW. Gestational diabetes and its impact on the neonate. *Neonatal Netw.* 2001;20(6):17–23. <https://doi.org/10.1891/0730-0832.20.6.17>.
- Jovanovic L. American diabetes association’s fourth international workshop-conference on gestational diabetes mellitus: summary and discussion therapeutic interventions. *Diabetes Care.* 1998;21:B131.
- Jovanovic L, Druzin M, Peterson CM. Effect of euglycemia on the outcome of pregnancy in insulin-dependent diabetic women as compared with normal control subjects. *Am J Med.* 1981;71(6):921–7. <http://www.ncbi.nlm.nih.gov/pubmed/7032287>
- Jovanovic L, Metzger BE, Knopp RH, et al. The diabetes in early pregnancy study: (beta)-Hydroxybutyrate levels in type 1 diabetic pregnancy compared with normal pregnancy. *Diabetes Care.* 1998;21(11):1978–84.
- Kahn BF, Davies JK, Lynch AM, Reynolds RM, L a B. Predictors of glyburide failure in the treatment of gestational diabetes. *Obstet Gynecol.* 2006;107(6):1303–9. <https://doi.org/10.1097/01.AOG.0000218704.28313.36>.

- Kampmann U, Madsen LR, Skajaa GO, Iversen DS, Moeller N, Ovesen P. Gestational diabetes: a clinical update. *World J Diabetes*. 2015;6(8):1065–72. <https://doi.org/10.4239/wjcd.v6.i8.1065>.
- Kapur A. Pregnancy: a window of opportunity for improving current and future health. *Int J Gynaecol Obstet*. 2011;115(Suppl):S50–1. [https://doi.org/10.1016/S0020-7292\(11\)60015-5](https://doi.org/10.1016/S0020-7292(11)60015-5).
- Kemball ML, McIver C, Milner RD, Nourse CH, Schiff D, Tiernan JR. Neonatal hypoglycaemia in infants of diabetic mothers given sulphonylurea drugs in pregnancy. *Arch Dis Child*. 1970;45(243):696–701. <http://www.ncbi.nlm.nih.gov/pubmed/5477685>
- Kerssen A, Valk HW, Visser GHA. Day-to-day glucose variability during pregnancy in women with type 1 diabetes mellitus: glucose profiles measured with the continuous glucose monitoring system. *BJOG Int J Obstet Gynaecol*. 2004;111(9):919–24. <https://doi.org/10.1111/j.1471-0528.2004.00203.x>.
- Kim C, Newton KM, Knopp RH. Gestational diabetes and the incidence of type 2 diabetes: a systematic review. *Diabetes Care*. 2002;25(10):1862–8. <https://doi.org/10.2337/diacare.25.10.1862>.
- Kim C, Ferrara A, McEwen LN, Marrero DG, Gerzoff RB, Herman WH. Preconception care in managed care: the translating research into action for diabetes study. *Am J Obstet Gynecol*. 2005;192(1):227–32. <https://doi.org/10.1016/j.ajog.2004.06.105>.
- Kitzmilller JL, Cloherty JP, Younger MD, et al. Diabetic pregnancy and perinatal morbidity. *Am J Obstet Gynecol*. 1978;131(5):560–80. <http://www.ncbi.nlm.nih.gov/pubmed/354386>
- Knopp RH, Magee MS, Raisys V, Benedetti T. Metabolic effects of hypocaloric diets in management of gestational diabetes. *Diabetes*. 1991;40(Suppl. 2):165–71.
- Kraemer J, Klein J, Lubetsky A, Koren G. Perfusion studies of glyburide transfer across the human placenta: implications for fetal safety. *Am J Obstet Gynecol*. 2006;195(1):270–4. <https://doi.org/10.1016/j.ajog.2005.12.005>.
- Kremer CJ, Duff P. Glyburide for the treatment of gestational diabetes. *Am J Obstet Gynecol*. 2004;190(5):1438–9. <https://doi.org/10.1016/j.ajog.2004.02.032>.
- Kulkarni K, Castle G, Gregory R, et al. Nutrition practice guidelines for type 1 diabetes mellitus positively affect dietitian practices and patient outcomes. *J Am Diet Assoc*. 1998;98(1):62–70. [https://doi.org/10.1016/S0002-8223\(98\)00017-0](https://doi.org/10.1016/S0002-8223(98)00017-0).
- Lain KY, Garabedian MJ, Daftary A, Jeyabalan A. Neonatal adiposity following maternal treatment of gestational diabetes with glyburide compared with insulin. *Am J Obstet Gynecol*. 2009;200(5). <https://doi.org/10.1016/j.ajog.2009.02.038>.
- Landon MB, Gabbe SG. Gestational diabetes mellitus. *Obstet Gynecol*. 2011;118(6):1379–93. <https://doi.org/10.1097/AOG.0b013e31823974e2>.
- Landon MB, Gabbe SG, Piana R, Mennuti MT, Main EK. Neonatal morbidity in pregnancy complicated by diabetes mellitus: predictive value of maternal glycemic profiles. *Am J Obstet Gynecol*. 1987;156(5):1089–95. [https://doi.org/10.1016/0002-9378\(87\)90116-5](https://doi.org/10.1016/0002-9378(87)90116-5).
- Landon MB, Spong CY, Thom E, et al. A multicenter, randomized trial of treatment for mild gestational diabetes. *N Engl J Med*. 2009;361(14):1339–48. <https://doi.org/10.1056/NEJMoa0902430>.
- Langer O. Prevention of macrosomia. *Baillieres Clin Obstet Gynaecol*. 1991;5(2):333–47. <http://www.ncbi.nlm.nih.gov/pubmed/1954717>
- Langer O, Mazze R. The relationship between large-for-gestational-age infants and glycemic control in women with gestational diabetes. *Am J Obstet Gynecol*. 1988;159(6):1478–83. <http://www.ncbi.nlm.nih.gov/pubmed/3207126>
- Langer O, Anyaegbunam A, Brustman L, Guidetti D, Levy J, Mazze R. Pregestational diabetes: insulin requirements throughout pregnancy. *Am J Obstet Gynecol*. 1988;159(3):616–21. <http://www.ncbi.nlm.nih.gov/pubmed/3048099>
- Langer O, Levy J, Brustman L, Anyaegbunam A, Merkatz R, Divon M. Glycemic control in gestational diabetes mellitus-how tight is tight enough: small for gestational age versus large for gestational age? *Am J Obstet Gynecol*. 1989;161(3):646–53. [https://doi.org/10.1016/0002-9378\(89\)90371-2](https://doi.org/10.1016/0002-9378(89)90371-2).
- Langer O, Berkus MD, Huff RW, Samueloff A. Shoulder dystocia: Should the fetus weighing  $\geq 4000$  grams be delivered by cesarean section? *Am J Obstet Gynecol*. 1991;165(4 PART 1): 831–7. [https://doi.org/10.1016/0002-9378\(91\)90424-P](https://doi.org/10.1016/0002-9378(91)90424-P).

- Langer O, Rodriguez DA, Xenakis EM, McFarland MB, Berkus MD, Arrendondo F. Intensified versus conventional management of gestational diabetes. *Am J Obstet Gynecol.* 1994;170(4):1036–46; discussion 1046–47. <http://www.ncbi.nlm.nih.gov/pubmed/8166187>
- Langer O, Conway DL, Berkus MD, Xenakis EM, Gonzales O. A comparison of glyburide and insulin in women with gestational diabetes mellitus. *N Engl J Med.* 2000;343(16):1134–8. <https://doi.org/10.1056/NEJM200010193431601>.
- Lean ME, Pearson DW, Sutherland HW. Insulin management during labour and delivery in mothers with diabetes. *Diabet Med.* 1990;7:162–4.
- Lepercq J, Lin J, Hall GC, et al. Meta-analysis of maternal and neonatal outcomes associated with the use of insulin glargine versus NPH insulin during pregnancy. *Obstet Gynecol Int.* 2012;2012:649070. <https://doi.org/10.1155/2012/649070>.
- Letter NM. Oral hypoglycaemic therapy in diabetic pregnancies. *Lancet Lond Engl.* 1974;2(7885):902–3. <http://www.ncbi.nlm.nih.gov/pubmed/4137793>
- Levy AL, Gonzalez JL, Rappaport VJ, Curet LB, Rayburn WF. Effect of labor induction on cesarean section rates in diabetic pregnancies. *J Reprod Med.* 2002;47(11):931–2.
- Li G, Zhao S, Cui S, Li L, Xu Y, Li Y. Effect comparison of metformin with insulin treatment for gestational diabetes: a meta-analysis based on RCTs. *Arch Gynecol Obstet.* 2015;292(1):111–20. <https://doi.org/10.1007/s00404-014-3566-0>.
- Linder N, Lahat Y, Kogan A, et al. Macrosomic newborns of non-diabetic mothers: anthropometric measurements and neonatal complications. *Arch Dis Child Fetal Neonatal Ed.* 2014;353–8. <https://doi.org/10.1136/archdischild-2013-305032>.
- Lv SS, Wang JY, Xu Y. Safety of insulin analogs during pregnancy: a meta-analysis. *Arch Gynecol Obstet.* 2015;292(4):749–56. <https://doi.org/10.1007/s00404-015-3692-3>.
- Magee MS, Knopp RH, Benedetti TJ. Metabolic effects of 1200-kcal diet in obese pregnant women with gestational diabetes. *Diabetes.* 1990;39(2):234–40.
- Masson EA, Patmore JE, Brash PD, et al. Pregnancy outcome in type 1 diabetes mellitus treated with insulin lispro (Humalog). *Diabet Med.* 2003;20(1):46–50. <https://doi.org/10.1046/j.1464-5491.2003.00840.x>.
- Mathiesen ER, Kinsley B, Amiel SA, et al. Maternal glycemic control and hypoglycemia in type 1 diabetic pregnancy: a randomized trial of insulin aspart versus human insulin in 322 pregnant women. *Diabetes Care.* 2007;30(4):771–6. <https://doi.org/10.2337/dc06-1887>.
- Mathiesen E, Hod M, Ivanisevic M, et al. Maternal efficacy and safety outcomes in a randomized, controlled trial comparing insulin detemir with NPH insulin in 310 pregnant women with type 1 diabetes. *Diabetes Care.* 2012;35(10):2012–7. <https://doi.org/10.2337/dc11-2264>.
- Mayer-Davis EJ, Rifas-Shiman SL, Zhou L, Hu FB, Colditz GA, Gillman MW. Breast-feeding and risk for childhood obesity: does maternal diabetes or obesity status matter? *Diabetes Care.* 2006;29(10):2231–7. <https://doi.org/10.2337/dc06-0974>.
- Mazze R, Yogeve Y, Langer O. Measuring glucose exposure and variability using continuous glucose monitoring in normal and abnormal glucose metabolism in pregnancy. *J Matern Fetal Neonatal Med.* 2012;25(7):1171–5. <https://doi.org/10.3109/14767058.2012.670413>.
- McCance DR, Damm P, Mathiesen ER, et al. Evaluation of insulin antibodies and placental transfer of insulin aspart in pregnant women with type 1 diabetes mellitus. *Diabetologia.* 2008;51(11):2141–3. <https://doi.org/10.1007/s00125-008-1120-y>.
- McIntyre HD, Metzger BE, Coustan DR, et al. Counterpoint: establishing consensus in the diagnosis of GDM following the HAPO study. *Curr Diab Rep.* 2014;14(6). <https://doi.org/10.1007/s11892-014-0497-x>.
- McIntyre HD, Colagiuri S, Roglic G, Hod M. Diagnosis of GDM: a suggested consensus. *Best Pract Res Clin Obstet Gynaecol.* 2015;29(2):194–205. <https://doi.org/10.1016/j.bpobgyn.2014.04.022>.
- Mecacci F, Carignani L, Cioni R, et al. Maternal metabolic control and perinatal outcome in women with gestational diabetes treated with regular or lispro insulin: comparison with non-diabetic pregnant women. *Eur J Obstet Gynecol Reprod Biol.* 2003;111(1):19–24. [https://doi.org/10.1016/S0301-2115\(03\)00157-X](https://doi.org/10.1016/S0301-2115(03)00157-X).

- Metzger BE. International association of diabetes and pregnancy study groups recommendations on the diagnosis and classification of hyperglycemia in pregnancy. *Diabetes Care*. 2010;33(3):676–82. <https://doi.org/10.2337/dc09-1848>.
- Metzger B, Buchanan T, Coustan D, et al. Summary and recommendations of the fifth international workshop-conference on gestational diabetes mellitus. *Diabetes Care*. 2007;30(2):S251–60. <https://doi.org/10.2337/dc07-s225>.
- Mills JL, Simpson JL, Driscoll SG, et al. Incidence of spontaneous abortion among normal women and insulin-dependent diabetic women whose pregnancies were identified within 21 days of conception. *N Engl J Med*. 1988;319(25):1617–23. <https://doi.org/10.1056/NEJM198812223192501>.
- Mimouni F, Miodovnik M, Siddiqi TA, Khoury J, Tsang RC. Perinatal asphyxia in infants of insulin-dependent diabetic mothers. *J Pediatr*. 1988;113(2):345–53. <http://www.ncbi.nlm.nih.gov/pubmed/3397799>
- Miodovnik M, Mimouni F, Tsang RC, et al. Management of the insulin-dependent diabetic during labor and delivery. Influences on neonatal outcome. *Am J Perinatol*. 1987;4(2):106–14. <https://doi.org/10.1055/s-2007-999750>.
- Moore LE, Clokey D, Rappaport VJ, Curet LB. Metformin compared with glyburide in gestational diabetes: a randomized controlled trial. *Obstet Gynecol*. 2010;115(1):55–9. <https://doi.org/10.1097/AOG.0b013e3181c52132>.
- Moos M. Preconceptional wellness as a routine objective for women's health care: an integrative strategy. *J Obstet Gynecol Neonatal Nurs*. 2003;32(4):550–6. <https://doi.org/10.1177/0884217503255302>.
- Moos M-K. From concept to practice: reflections on the preconception health agenda. *J Women's Health (Larchmt)*. 2010;19(3):561–7. <https://doi.org/10.1089/jwh.2009.1411>.
- Moses RG, Cheung NW. Point: universal screening for gestational diabetes mellitus. *Diabetes Care*. 2009;32(7):1349–51. <https://doi.org/10.2337/dc09-0188>.
- Mukhopadhyay P, Bag TS, Kyal A, Saha DP, Khalid N. Oral hypoglycemic glibenclamide: can it be a substitute to insulin in the management of gestational diabetes mellitus? A comparative study. *J SAFOG*. 2012;4(1):28–31.
- Nanovskaya TN, Patrikeeva S, Hemauer S, et al. Effect of albumin on transplacental transfer and distribution of rosiglitazone and glyburide. *J Matern Fetal Neonatal Med*. 2008;21(3):197–207. <https://doi.org/10.1080/14767050801929901>.
- National Diabetes Data Group. Classification and diagnosis of diabetes mellitus and other categories of glucose intolerance. *Diabetes*. 1979;28(December):1039–57. <https://doi.org/10.2337/diab.28.12.1039>.
- Naylor CD, Sermer M, Chen E, Farine D. Selective screening for gestational diabetes mellitus. Toronto Trihospital Gestational Diabetes Project Investigators. *N Engl J Med*. 1997;337(22):1591–6. <https://doi.org/10.1056/NEJM199711273372204>.
- NHS. Diabetes in pregnancy. *Clin Endocrinol Metab*. 1972;2008(July):61–6. <http://www.sciencedirect.com/science/article/pii/S0300595X72800392>
- Nielsen KK, de Courten M, Kapur A. The urgent need for universally applicable simple screening procedures and diagnostic criteria for gestational diabetes mellitus – lessons from projects funded by the World Diabetes Foundation. *Glob Health Action*. 2012;1(5):17277.
- Nielsen KK, Kapur A, Damm P, de Courten M, Bygbjerg IC. From screening to postpartum follow-up – the determinants and barriers for gestational diabetes mellitus (GDM) services, a systematic review. *BMC Pregnancy Childbirth*. 2014;14:41. <https://doi.org/10.1186/1471-2393-14-41>.
- No Title. 2009. <http://www.ncbi.nlm.nih.gov/pubmed/20669500>
- O'Reilly M, Avalos G, Denny MC, O'Sullivan EP, Dunne FP. Breast-feeding is associated with reduced postpartum maternal glucose intolerance after gestational diabetes. *Ir Med J*. 2012;105(5 Suppl):31–6.
- O'Sullivan JB, Mahan CM, Charles D, Dandrow RV. Screening criteria for high risk gestational diabetic patients. *Am J Obstet Gynecol*. 1973;116(7):895–900.
- Offspring T, Tofu FM. Metformin in gestational diabetes. *Heal*. 2011;34. <https://doi.org/10.2337/dc11-0660>.



- Ogunyemi D, Jesse M, Davidson M. Comparison of glyburide versus insulin in management of gestational diabetes mellitus. *Endocr Pract.* 2007;13(4):427–8. <https://doi.org/10.4158/EP.13.4.427>.
- Owen CG, Martin RM, Whincup PH, Smith GD, Cook DG. Does breastfeeding influence risk of type 2 diabetes in later life? A quantitative analysis of published evidence. *Am J Clin Nutr.* 2006;84(5):1043–54. 84/5/1043 [pii]
- Pedersen J. Weight and length at birth of infants of diabetic mothers. *Eur J Endocrinol.* 1954;16(4):330–42. <https://doi.org/10.1530/acta.0.0160330>.
- Pedersen J, Pedersen LM, Andersen B. Assessors of fetal perinatal mortality in diabetic pregnancy. Analysis of 1,332 pregnancies in the Copenhagen series, 1946–1972. *Diabetes.* 1974;23(4):302–5. <http://www.ncbi.nlm.nih.gov/pubmed/4207365>
- Persson B, Swahn M-L, Hjertberg R, et al. Insulin lispro therapy in pregnancies complicated by type 1 diabetes mellitus. *Diabetes Res Clin Pract.* 2002;58(2):115–21. [https://doi.org/10.1016/S0168-8227\(02\)00141-9](https://doi.org/10.1016/S0168-8227(02)00141-9).
- Pertot T, Molyneaux L, Tan K, Ross GP, Yue DK, Wong J. Can common clinical parameters be used to identify patients who will need insulin treatment in gestational diabetes mellitus? *Diabetes Care.* 2011;34(10):2214–6. <https://doi.org/10.2337/dc11-0499>.
- Pettitt DJ, Ospina P, Kolaczynski JW, Jovanovic L. Comparison of an insulin analog, insulin aspart, and regular human insulin with no insulin in gestational diabetes mellitus. *Diabetes Care.* 2003;26(1):183–6. <http://www.ncbi.nlm.nih.gov/pubmed/12502678>
- Pettitt DJ, Ospina P, Howard C, Zisser H, Jovanovic L. Efficacy, safety and lack of immunogenicity of insulin aspart compared with regular human insulin for women with gestational diabetes mellitus. *Diabet Med.* 2007;24(10):1129–35. <https://doi.org/10.1111/j.1464-5491.2007.02247.x>.
- Piacquadio K, Hollingsworth DR, Murphy H. Effects of in-utero exposure to oral hypoglycaemic drugs. *Lancet.* 1991;338(8771):866–9. [https://doi.org/10.1016/0140-6736\(91\)91512-S](https://doi.org/10.1016/0140-6736(91)91512-S).
- Plagemann A, Harder T, Franke K, Kohlhoff R. Long-term impact of neonatal breast-feeding on body weight and glucose tolerance in children of diabetic mothers. *Diabetes Care.* 2002;25(1):16–22. <http://www.ncbi.nlm.nih.gov/pubmed/11772895>
- Pollex EK, Feig DS, Lubetsky A, Yip PM, Koren G. Insulin glargine safety in pregnancy: a transplacental transfer study. *Diabetes Care.* 2010;33(1):29–33. <https://doi.org/10.2337/dc09-1045>.
- Pollex E, Moretti ME, Koren G, Feig DS. Safety of insulin glargine use in pregnancy: a systematic review and meta-analysis. *Ann Pharmacother.* 2011;45(1):9–16. <https://doi.org/10.1345/aph.1P327>.
- Rae A, Bond D, Evans S, North F, Roberman B, Walters B. A randomised controlled trial of dietary energy restriction in the management of obese women with gestational diabetes. *Aust N Z J Obstet Gynaecol.* 2000;40(4):416–22.
- Ratner RE, Christophi CA, Metzger BE, et al. Prevention of diabetes in women with a history of gestational diabetes: effects of metformin and lifestyle interventions. *J Clin Endocrinol Metab.* 2008;93(12):4774–9. <https://doi.org/10.1210/jc.2008-0772>.
- Reece EA. The fetal and maternal consequences of gestational diabetes mellitus. *J Matern Fetal Neonatal Med.* 2010;23(3):199–203. <https://doi.org/10.3109/14767050903550659>.
- Rizzo T, Metzger BE, Burns WJ, Burns K. Correlations between antepartum maternal metabolism and child intelligence. *N Engl J Med.* 1991;325(13):911–6. <https://doi.org/10.1056/NEJM199109263251303>.
- Rø TB, Ludvigsen HV, Carlsen SM, Vanky E. Growth, body composition and metabolic profile of 8-year-old children exposed to metformin in utero. *Scand J Clin Lab Invest.* 2012;72(7):570–5. <https://doi.org/10.3109/00365513.2012.712319>.
- Rochon M, Rand L, Roth L, Gaddipati S. Glyburide for the management of gestational diabetes: risk factors predictive of failure and associated pregnancy outcomes. *Am J Obstet Gynecol.* 2006;195(4):1090–4. <https://doi.org/10.1016/j.ajog.2006.07.029>.
- Rouse DJ, Owen J. Prophylactic cesarean delivery for fetal macrosomia diagnosed by means of ultrasonography – a Faustian bargain? *Am J Obstet Gynecol.* 1999;181:332–8. [https://doi.org/10.1016/S0002-9378\(99\)70557-0](https://doi.org/10.1016/S0002-9378(99)70557-0).

- Rowan JA, Hague WM, Gao W, et al. Metformin versus insulin for the treatment of gestational diabetes. *N Engl J Med.* 2008;358(19):2003–15. <https://doi.org/10.1097/01.ogx.0000327772.43649.2a>.
- Russo LM, Nobles C, Ertel KA, Chasan-Taber L, Whitcomb BW. Physical activity interventions in pregnancy and risk of gestational diabetes mellitus: a systematic review and meta-analysis. *Obstet Gynecol.* 2015;125(3):576–82. <https://doi.org/10.1097/AOG.0000000000000691>.
- Sacks DB. Diagnosis of gestational diabetes mellitus: it is time for international consensus. *Clin Chem.* 2014;60(1):141–3. <https://doi.org/10.1373/clinchem.2013.206920>.
- Sacks DA, Greenspoon JS, Abu-Fadil S, Henry HM, Wolde-Tsadik G, Yao JFF. Toward universal criteria for gestational diabetes: the 75-gram glucose tolerance test in pregnancy. *Am J Obstet Gynecol.* 1995;172(2 PART 1):607–14. [https://doi.org/10.1016/0002-9378\(95\)90580-4](https://doi.org/10.1016/0002-9378(95)90580-4).
- Salvesen DR, Freeman J, Brudenell JM, Nicolaides KH. Prediction of fetal acidaemia in pregnancies complicated by maternal diabetes mellitus by biophysical profile scoring and fetal heart rate monitoring. *Br J Obstet Gynaecol.* 1993;100(3):227–33. <https://doi.org/10.1111/j.1471-0528.1993.tb15235.x>.
- Scherbaum WA, Lankisch MR, Pawlowski B, Somville T. Insulin Lispro in pregnancy – retrospective analysis of 33 cases and matched controls. *Exp Clin Endocrinol Diabetes.* 2002;110(1):6–9. <https://doi.org/10.1055/s-2002-19987>.
- Schmidt MI, Duncan BB, Reichelt AJ, et al. Gestational diabetes mellitus diagnosed with a 2-h 75-g oral glucose tolerance test and adverse pregnancy outcomes. *Diabetes Care.* 2001;24(7):1151–5. <https://doi.org/10.2337/diacare.24.7.1151>.
- Sermer M, Naylor CD, Gare DJ, et al. Impact of increasing carbohydrate intolerance on maternal-fetal outcomes in 3637 women without gestational diabetes. The Toronto tri-hospital gestational diabetes project. *Am J Obstet Gynecol.* 1995;173:146–56. [https://doi.org/10.1016/0002-9378\(95\)90183-3](https://doi.org/10.1016/0002-9378(95)90183-3).
- Silva JC, Pacheco C, Bizato J, De Souza BV, Ribeiro TE, Bertini AM. Metformin compared with glyburide for the management of gestational diabetes. *Int J Gynecol Obstet.* 2010;111(1):37–40. <https://doi.org/10.1016/j.ijgo.2010.04.028>.
- Silva JC, Fachin DRRN, Coral ML, Bertini AM. Perinatal impact of the use of metformin and glyburide for the treatment of gestational diabetes mellitus. *J Perinat Med.* 2012;40(3):225–8. <https://doi.org/10.1515/jpm-2011-0175>.
- Simmons D, Moses RG. Gestational diabetes mellitus: to screen or not to screen?: is this really still a question? *Diabetes Care.* 2013;36(10):2877–8. <https://doi.org/10.2337/dc13-0833>.
- Skouby SO, Mølsted-Pedersen L, Petersen KR. 13 Contraception for women with diabetes: an update. *Baillieres Clin Obstet Gynaecol.* 1991;5(2):493–503. [https://doi.org/10.1016/S0950-3552\(05\)80109-9](https://doi.org/10.1016/S0950-3552(05)80109-9).
- Smোক IW, Sadler TW. Embryopathic effects of short-term exposure to hypoglycemia in mouse embryos in vitro. *Am J Obstet Gynecol.* 1990;163(2):619–24.
- Snyder J, Gray-Donald K, Koski KG. Predictors of infant birth weight in gestational diabetes. *Am J Clin Nutr.* 1994;59(6):1409–14.
- Sutherland HW, Stowers JM, Cormack JD, et al. Evaluation of chlorpropamide in chemical diabetes diagnosed during pregnancy. *Br Med J.* 1973;3(5870):9–13.
- Sutherland HW, Bewsher PD, Cormack JD. Effect of moderate dosage of chlorpropamide in pregnancy on fetal outcome. *Arch Dis Child.* 1974;49(4):283–91.
- Tempe A, Mayanglambam RD. Glyburide as treatment option for gestational diabetes mellitus. *J Obstet Gynaecol Res.* 2013;39(6):1147–52. <https://doi.org/10.1111/jog.12042>.
- Tertti K, Ekblad U, Vahlberg T, Rönnemaa T. Comparison of metformin and insulin in the treatment of gestational diabetes: a retrospective, case-control study. *Rev Diabet Stud.* 2008;5(2):95–101. <https://doi.org/10.1900/RDS.2008.5.95>.
- The American College of Obstetricians and Gynecologists. Weight gain during pregnancy, Committee on Practice Bulletins - Obstetrics. Practice Bulletin No. 137: Gestational diabetes mellitus. *Obstet Gynecol.* 2013;122(2 Pt 1):406–16 vol. 548. <https://doi.org/10.1097/01.AOG.0000433006.09219.fl>.

- Towner D, Kjos SL, Leung B, et al. Congenital malformations in pregnancies complicated by NIDDM. *Diabetes Care*. 1995;18(11):1446–51. <https://doi.org/10.2337/diacare.18.11.1446>.
- Walker JD. NICE guidance on diabetes in pregnancy: management of diabetes and its complications from preconception to the postnatal period. NICE clinical guideline 63. London, March 2008. *Diabet Med*. 2008;25(9):1025–7. <https://doi.org/10.1111/j.1464-5491.2008.02532.x>.
- Weintrob N, Karp M, Moshe H. Short- and long-range complications in offspring of diabetic mothers. *J Diabetes Complicat*. 1996;10(5):294–301. [https://doi.org/10.1016/1056-8727\(95\)00080-1](https://doi.org/10.1016/1056-8727(95)00080-1).
- Weiss PAM. Gestational diabetes: a survey and the graz approach to diagnosis and therapy. In: *Gestational diabetes*. Vienna: Springer; 1988. p. 1–55. [https://doi.org/10.1007/978-3-7091-8925-2\\_1](https://doi.org/10.1007/978-3-7091-8925-2_1).
- Wyatt JW, Frias JL, Hoyme HE, et al. Congenital anomaly rate in offspring of mothers with diabetes treated with insulin lispro during pregnancy. *Diabet Med*. 2005;22(6):803–7. <https://doi.org/10.1111/j.1464-5491.2004.01498.x>.
- Xu H, Simonet F, Luo Z-C. Optimal birth weight percentile cut-offs in defining small- or large-for-gestational-age. *Acta Paediatr*. 2010;99(4):550–5. <https://doi.org/10.1111/j.1651-2227.2009.01674.x>.
- Yogev Y, Ben-Haroush A, Chen R, Rosenn B, Hod M, Langer O. Diurnal glycemc profile in obese and normal weight nondiabetic pregnant women. *Am J Obstet Gynecol*. 2004a;191:949–53. <https://doi.org/10.1016/j.ajog.2004.06.059>.
- Yogev Y, Ben-Haroush A, Chen R, Rosenn B, Hod M, Langer O. Undiagnosed asymptomatic hypoglycemia: diet, insulin, and glyburide for gestational diabetic pregnancy. *Obstet Gynecol*. 2004b;104(1):88–93. <https://doi.org/10.1097/01.AOG.0000129239.82126.a1>.
- Yogev Y, Melamed N, Chen R, Nassie D, Pardo J, Hod M. Glyburide in gestational diabetes – prediction of treatment failure. *J Matern Fetal Neonatal Med*. 2011;24(6):842–6. <https://doi.org/10.3109/14767058.2010.531323>.
- Zhuo Z, Wang A, Yu H. Effect of metformin intervention during pregnancy on the gestational diabetes mellitus in women with polycystic ovary syndrome: a systematic review and meta-analysis. *J Diab Res*. 2014;2014:381231. <https://doi.org/10.1155/2014/381231>.
- Zucker P, Simon G. Prolonged symptomatic neonatal hypoglycemia associated with maternal chlorpropamide therapy. *Pediatrics*. 1968;42(5):824–5. <http://www.ncbi.nlm.nih.gov/pubmed/5685364>



# Diabetes, Depression, and Cognitive Disorders

# 23

Richard I. G. Holt

## Contents

Introduction .....	688
Diabetes and Depression .....	689
Epidemiology of Diabetes and Depression .....	689
Depression or Distress .....	691
Specific Populations .....	692
Etiology of Diabetes and Depression .....	693
Which People with Diabetes Are at Risk of Depression? .....	693
Why Do People with Diabetes Develop Depression? .....	693
Why Do People with Depression Develop Diabetes? .....	694
Do Common Antecedents Explain the Association Between Diabetes and Depression? .....	695
Consequences of Depression in Diabetes .....	696
Management of People with Diabetes and Depression .....	696
Screening and Diagnosis of Depression .....	696
Treatment of Depression in People with Diabetes .....	698
Psychological Treatment .....	698
Pharmacotherapy .....	698
Models of Care .....	699
Cognitive Function .....	700
Diabetes and Cognition .....	700
Cognitive Dysfunction in Children and Adolescents .....	700
Cognitive Dysfunction in Adults with Diabetes .....	702
Dementia .....	703
Diabetes and Dementia .....	704
Clinical Implications of Dementia in People with Diabetes .....	705
Prevention of Dementia .....	705
Diagnosis of Dementia .....	705

---

R. I. G. Holt (✉)

Human Development and Health Academic Unit, Faculty of Medicine, University of Southampton, Southampton, UK

e-mail: [r.i.g.holt@soton.ac.uk](mailto:r.i.g.holt@soton.ac.uk)

Treatment of Dementia .....	706
Management of Diabetes in Someone with Dementia .....	707
Conclusions .....	707
References .....	707

### Abstract

The interactions between diabetes and the mind are complex; physical illness increases the risk of a number of psychiatric disorders, while mental illness and its treatment also alter the risks of diabetes and worsen both acute metabolic and long-term outcomes of diabetes.

The prevalence of depression is approximately 1.5–2-fold higher in people with diabetes compared with the general population. Approximately 10% of people with diabetes will have a formal diagnosis of depression and around a quarter have significant depressive symptoms. Microvascular and macrovascular complications and treatment with insulin are associated with higher rates of depressive symptoms. The underlying mechanisms are multifactorial and include genetic and environmental factors as well as disease and treatment effects. The presence of depression adversely affects diabetes outcomes; quality of life and glycemic control are worsened, while the rates of microvascular and macrovascular complications and mortality are increased in people with depression. Screening for depression in people with diabetes and prompt treatment, where necessary, are recommended.

Diabetes has modest effects on certain aspects of cognition, including general intelligence, psychomotor speed, and mental flexibility, particularly when diagnosed in children under the age of 7 years.

Diabetes increases the risk of vascular dementia and Alzheimer's disease, even after adjustment for traditional cardiovascular risk factors. Approximately 1 in 15 cases of dementia is attributable to diabetes. Insulin directly affects  $\beta$ -amyloid formation. Dementia impedes the person with diabetes' ability to self-manage their diabetes and mandates a change in glycemic targets and management strategies.

### Keywords

Diabetes · Depression · Diabetes-related distress · Cognitive function · Dementia · Alzheimer's disease

## Introduction

An effect of diabetes on the mind and vice versa has been recognized for many centuries; in the seventeenth century, Thomas Willis discussed how “*diabetes is a consequence of prolonged sorrow*” (Willis 1675). As the brain is highly vascular and dependent on glucose for its normal functioning, it is perhaps unsurprising that diabetes affects cognitive function and the risk of mental illness. What is surprising is that clinicians looking after people with diabetes frequently ignore this association. Nevertheless, the effects of comorbid mental illness on someone with diabetes

may be profound as the comorbidity worsens the clinical outcomes of both conditions. Quality of life across a broad range of domains is worsened, while the individual's ability to self-manage their diabetes is impaired, ultimately leading to a higher incidence of complications and reduced life expectancy (Holt and Katon 2012).

Despite the pressing clinical need to consider the comorbidity, in many countries, mental and physical health services are not properly integrated; this leaves diabetes services poorly equipped and organized to address both the physical and psychological needs of patients in the same setting (Mitchell et al. 2009). Over the last decade, however, there have been increasing levels of interest in comorbidity from researchers, who have made considerable progress in understanding the epidemiology and underlying mechanisms explaining the association. This is beginning to change clinical practice with national and international guidelines highlighting the importance of assessing and treating the psychological sequelae of diabetes (International Diabetes Federation 2012; National Institute for Health and Care Excellence 2015a, b).

This chapter will first describe the complex relationship between diabetes and depression before considering the effects of diabetes on cognitive function, with particular reference to the association between diabetes and dementia.

---

## Diabetes and Depression

Depression is a mood disorder, which is characterized by persistent low mood and loss of interest or pleasure in life. Other symptoms include weight loss or gain, change in sleep patterns, agitation or retardation, fatigue or loss of energy, feelings of worthlessness or guilt, diminished ability to think or concentrate, and recurrent thoughts of death including suicidal ideation, respectively.

Depressive symptoms are common in the general population and vary considerably in severity. Consequently, a clinical diagnosis of depression is defined by the number, severity, and duration of symptoms; the most widely used diagnostic criteria in current practice are those of the Diagnostic and Statistical Manual of Mental Disorders, 5th Edition (DSM-5) (American Psychiatric Association 2005) (Table 1). This degree of symptomatology is associated with significant disability and dysfunction, but it is important to recognize that less severe depressive symptoms may still adversely affect diabetes self-care and outcomes.

---

## Epidemiology of Diabetes and Depression

Depression within the general population is common and its prevalence is increasing. It is predicted to become the second leading global cause of disability after heart disease by 2020 (Murray and Lopez 1997). The lifetime prevalence varies widely across the globe from 3% in Japan to 17% in the USA, falling between 8% and 12% in most countries. At any one time, approximately 3–5% of men and 8–10% of

**Table 1** The Diagnostic and Statistical Manual of Mental Disorders, 5th Edition (DSM-5): definition of a “major” depressive episode

A. Five (or more) of the following symptoms have been present during the same 2-week period and represent a change from previous functioning; at least one of the symptoms is either (1) depressed mood or (2) loss of interest or pleasure
Depressed mood most of the day, nearly every day, as indicated by either subjective report (e.g., feels sad or empty) or observation made by others (e.g., appears tearful)
<ul style="list-style-type: none"> <li>• Markedly diminished interest or pleasure in all, or almost all, activities most of the day, nearly every day (as indicated by either subjective account or observation made by others)</li> <li>• Significant weight loss when not dieting or weight gain (e.g., a change of &gt;5% of body weight in a month) or decrease or increase in appetite nearly every day</li> <li>• Insomnia or hypersomnia nearly every day</li> <li>• Psychomotor agitation or retardation nearly every day (observable by others, not merely subjective feelings of restlessness or being slowed down)</li> <li>• Fatigue or loss of energy nearly every day</li> <li>• Feelings of worthlessness or excessive or inappropriate guilt (which may be delusional) nearly every day (not merely self-reproach or guilt about being sick)</li> <li>• Diminished ability to think or concentrate, or indecisiveness, nearly every day (either by subjective account or as observed by others)</li> <li>• Recurrent thoughts of death (not just fear of dying), recurrent suicidal ideation without a specific plan, or a suicide attempt or a specific plan for committing suicide</li> </ul>
B. The symptoms cause clinically significant distress or impairment in social, occupational, or other important areas of functioning
C. The symptoms are not due to the direct physiological effects of a substance (e.g., a drug of abuse, a medication) or a general medical condition (e.g., hypothyroidism)

women have depression. Given the high prevalence of diabetes and depression, one would expect a degree of comorbidity, but the current evidence suggests that depression occurs more frequently in people with diabetes and vice versa than would be expected by chance (Holt et al. 2014).

Recent meta-analyses have demonstrated that significant depressive symptoms affect approximately 1 in 3–4 adults with diabetes, while a formal diagnosis of depressive disorders is made in approximately 10–15%, equivalent to a 1.5–2-fold increased prevalence (Anderson et al. 2001; Ali et al. 2006). Longitudinal cohort studies report the incidence of depression to be 15–24% higher in people with diabetes compared with those without diabetes (Nouwen et al. 2010; Mezuk et al. 2008). On the other hand, the incidence of type 2 diabetes is also increased by 15–37% among people with depression (Mezuk et al. 2008; Knol et al. 2006), indicating the bidirectional nature of the relationship between these conditions. Episodes of depression appear to be more persistent and more likely to relapse among people with diabetes (Nefs et al. 2012), which may, in part, explain the discrepancy between the relative incidence and prevalence figures.

Although the literature is consistent in showing an increased prevalence of depression in people with diabetes and vice versa, within each of the meta-analyses,

there is considerable variation in risk estimates. This variation stems in part from the meaning of the word “*depression*,” which spans from relatively minor, occasional negative mood symptoms to life-threatening disabling conditions (Holt et al. 2014). More recently, papers have started to differentiate between “*depressive symptoms*” and “*depression*,” and this change in definition partly explains why current risk estimates of “*depression*” are lower than former ones. Another reason why earlier studies reported higher prevalence rates is because the studies recruited selected patient populations, often drawing from specialist diabetes clinics, where referral patterns and other differences in demographic characteristics, such as ethnicity, may increase the likelihood of depression.

The gold standard diagnostic procedure is a diagnostic interview, such as the Structured Clinical Interview for DSM-IV-TR Axis I Disorders (SCID) interview (First et al. 2002) or the Schedule for Clinical Assessment in Neuropsychiatry 2.1 (World Health Organisation 1999), but these are time-consuming and are unfeasible in most large epidemiological studies. Consequently, many studies have relied on self-rating scores, which tend to overestimate the true prevalence of depression and only provide an estimate of true caseness. These questionnaires may further exaggerate the prevalence of depression because of the overlap of the symptoms of diabetes and depression (Roy et al. 2012).

## Depression or Distress

Some authors have argued that much of the psychopathology previously identified as depression is in fact “diabetes-related distress” (Fisher et al. 2016). This concept captures the emotional distress associated with patients living with diabetes (Fisher et al. 2010), with the topmost frequently reported problems including:

- Worries about the future and the possibility of serious complications.
- Feeling guilty or anxious when you get off track with your diabetes management.
- Feeling scared when you think about living with diabetes.
- Feeling discouraged with your diabetes regimen.
- Feeling depressed when you think about living with diabetes.

These symptoms are recognized in up to 60% of people with type 1 diabetes or insulin-treated type 2 diabetes (Polonsky et al. 1995; Sturt et al. 2015) and are negatively associated with diabetes self-care and optimal glycemic control (Polonsky et al. 1995). Indeed HbA<sub>1c</sub> correlates more closely with diabetes-related distress than depression. These feelings are more likely to develop in those with long-standing diabetes and in those with recurrent severe hypoglycemia. Given the commonality of some symptoms, e.g., low mood and guilt, it is unsurprising that many people are reported to display both diabetes-related distress and depressive symptoms with ~30% overlapping variance. Nevertheless, as well as the distinct



association with glycemic control, the association with self-management also differs between distress and depression, strengthening the view that these are two distinct entities.

## Specific Populations

Many studies examining the prevalence of depression in people with diabetes have not differentiated between the types of diabetes. This limitation is important because people with type 2 diabetes are generally older and depression prevalence varies with age, the rates of various diabetic complications and other comorbid conditions (e.g., obesity and heart disease) differ, and management strategies are different. Because the prevalence of type 1 diabetes is so much lower than type 2 diabetes, people with type 1 diabetes are underrepresented in depression association studies. One review of depression in type 1 diabetes (Barnard et al. 2006), however, reported that depression was present in 12%, compared with 3.2% in people without diabetes. However, if studies without control groups and interview ascertainment were excluded, the estimated prevalence fell to 7.8%, which was no longer statistically significantly different from people without diabetes (odds ratio [OR] 2.4, 95% CI -0.7 to 5.4). A recent study of 368 individuals with type 1 diabetes found an unexpectedly low rate of major depressive disorder (3.5%) and highlighted the marked difference in estimated prevalence rates using self-rated questionnaires (11.4%) compared with diagnostic interviews, again, perhaps, reflecting an effect of the overlap with diabetes-related distress (Fisher et al. 2016).

Although many of the early studies were undertaken in Western Europe and North America, a recent report including 231,797 adults from 47 countries using data from the World Health Organization World Health Survey found a twofold increase in episodes of depressive symptoms in people with diabetes living in South America, Asia, and Europe (Table 2) (Mommersteeg et al. 2013). No increase in depressive symptoms was seen in people living in Africa, but this may reflect less complete case ascertainment because of cultural differences in the understanding of depression.

Although there are few data, depression rates (9–26%) also appear elevated in children and adolescents with diabetes (Holt et al. 2014).

**Table 2** Increased risk of depressive episodes in people with and without diabetes in four continents after adjustment for age, sex, education, BMI, smoking, and physical activity (Mommersteeg et al. 2013)

	OR	95% CI
World	2.36	1.91–2.92
Africa	0.86	0.54–1.37
South America	1.98	1.46–2.68
Asia	2.16	1.38–3.37
Europe	2.47	1.73–3.52

## **Etiology of Diabetes and Depression**

### **Which People with Diabetes Are at Risk of Depression?**

Female sex, marital status, childhood adversity, and social deprivation are all risk factors for depression in otherwise healthy individuals, and these appear to operate equally in people with diabetes. However, in addition, there are a number of diabetes specific and treatment risk factors associated with the development of depression.

Poor glycemic control and recurrent hypoglycemia are risk factors for depression, in part as a direct effect of hypoglycemia and hyperglycemia on brain function as well as the psychological effects of abnormal glucose levels. Animal models of diabetes have loss of hippocampal integrity and neurogenesis (Ho et al. 2013), while hippocampal atrophy has also been shown in MRI studies of people with diabetes (Lyoo et al. 2009). These structural changes are associated with neurotransmitter abnormalities, including increased prefrontal glutamate-glutamine-gamma-aminobutyric acid levels, which have been observed in people with type 1 diabetes in a manner that correlates with mild depressive symptoms.

Diabetes is not the only chronic physical condition associated with the development of depression, which also occurs more commonly in people with cardiovascular disease (Carney and Freedland 2003), cancer (Sellick and Crooks 1999), and inflammatory arthropathies among others (Matcham et al. 2013). As disease burden increases, so does the prevalence of depressive symptoms. It is, therefore, unsurprising that depressive symptoms are more common in people with diabetes who have developed either macrovascular or microvascular complications (de Groot et al. 2001). In a specialized outpatient clinic, people with two or more diabetes complications had twice the risk of depression, with neuropathy and nephropathy showing the strongest association with depression (van Steenberg-Weijnenburg et al. 2011). Sexual dysfunction and painful peripheral neuropathy also appear to be particularly associated with depression (de Groot et al. 2001).

People with insulin-treated type 2 diabetes have higher rates of depression compared to those treated with lifestyle interventions or noninsulin medications (Hermanns et al. 2005; Li et al. 2008). Exactly why this is the case is uncertain but probably has more to do with the increased treatment demands including intensive self-monitoring of blood glucose, longer duration of disease, and higher rates of diabetes complications than a direct effect of insulin per se (Li et al. 2008).

### **Why Do People with Diabetes Develop Depression?**

The traditional view is that people with diabetes develop depression because of the psychological response to living with a chronic condition that is associated with unpleasant consequences and treatment that place heavy behavioral demands on the individual. There is support for this hypothesis as a meta-analysis indicated that the rates of depression were only increased among people with diagnosed diabetes while those with undiagnosed diabetes or impaired glucose regulation had

no difference in depressive symptoms compared to those with normal glucose metabolism (Nouwen et al. 2011). This finding is important for clinicians who have the responsibility of communicating the diagnosis and its implications to people with new onset diabetes in a sensitive and compassionate manner to help people adjust to the diagnosis.

According to a German study, adults with new onset type 1 diabetes were more than twice as likely to develop a major depressive episode (5.8% vs. 2.7%), although the difference was only statistically significant in women (Petрак et al. 2003). By contrast, the situation appears less clear cut in people with type 2 diabetes where several studies have shown that the diagnosis has little impact on well-being (Adriaanse et al. 2004; Pibernik-Okanovic et al. 1996); the higher rates of depression only start to appear as the disease moves from being asymptomatic to one where complications begin to occur and where treatment demands increase.

This psychological model does not preclude other biological mechanisms, and it is important to recognize that acute changes in glucose may lead to a change in mood (Hermanns et al. 2007). Whether long-term changes or glucose variability may trigger depression directly is uncertain but changes in brain structure and function have been seen in the areas responsible for mood in people with type 1 diabetes (Lyoo et al. 2009).

## Why Do People with Depression Develop Diabetes?

The low mood and loss of interest in pleasurable activities may lead to changes in behavior that increase the risk of diabetes. People with depression tend to eat less prudent diets (comfort eating is a readily understandable concept), are less likely to undertake regular physical activity, and are more likely to be smokers, all of which increase the risk of diabetes (McMartin et al. 2013; Payne et al. 2012; Weyerer 1992).

Depression is associated with poorer self-care management. This has been studied in more depth in people with established diabetes where people with comorbid depression are more likely to miss medical appointments and are less likely to follow advice about medication use, glucose monitoring, and foot care (Gonzalez et al. 2008). In people with established diabetes, this is associated with poorer diabetes outcomes, but if similar patterns of behavior predated the diagnosis of diabetes, this may have contributed to its onset.

Several biological changes occur in depression, including alterations in the hypothalamic-pituitary-adrenal (HPA) axis and inflammatory markers that could lead to increased insulin resistance and consequently risk of diabetes (Champaneri et al. 2010). Subclinical hypercortisolism, blunted diurnal cortisol rhythm, and hypocortisolism with impaired glucocorticoid sensitivity have all been observed in depression, while inflammatory changes include elevated concentrations of C-reactive protein, tumor necrosis factor- $\alpha$  (TNF- $\alpha$ ), and proinflammatory cytokines, which have been implicated in causing sickness behavior in animal models and

depression in humans (Musselman et al. 2003; Dantzer et al. 2008). Disrupted sleep, which is common in depression, may be a further biological mechanism linking to diabetes as poor sleep quality and altered circadian rhythms are associated with an increased risk of diabetes through insulin resistances (Gangwisch 2009).

There have been concerns that the use of at least some antidepressants may worsen the risk of diabetes (Barnard et al. 2013) as substantial weight gain may occur with certain antidepressants, including mirtazapine, amitriptyline, and paroxetine (Serretti and Mandelli 2010). Case reports and early observational studies demonstrated a consistent association between antidepressant usage and risk of diabetes; however, more recent cohort studies have shown much lower odds ratios, to the point where the association could be explained by confounding, and the antidepressant use is merely a marker of individuals at high risk of diabetes. Randomized controlled trials have reported both hyperglycemic and hypoglycemic effects suggesting that not all antidepressants are alike (Barnard et al. 2013).

### **Do Common Antecedents Explain the Association Between Diabetes and Depression?**

Both diabetes and depression occur more frequently among people from lower socioeconomic classes raising the possibility that both conditions occur because of shared environmental risk factors. The importance of social status was demonstrated in a recent study from Denmark, which showed that while all people with diabetes were more likely to develop depression than those without diabetes, those from lower employment and income groups were disproportionately affected (Cleal et al. 2017).

It is uncertain how the adult environment increases the risk of diabetes, but poor physical (e.g., traffic, noise, and decreased walkability) and social environments (e.g., lower social cohesion, increased violence, and decreased residential stability) are associated with worse diet and lower physical activity levels that predispose to obesity, diabetes, and depression (de Vet et al. 2011). Although it is impossible to determine causality from these observational studies, dysfunctional HPA axis activity and disruption of its normal circadian rhythm (i.e., blunted profile) (Skinner et al. 2011; Brenner et al. 2013; Karb et al. 2012; Do et al. 2011; Dulin-Keita et al. 2012) as well as enhanced inflammation have all been observed in people living in adverse neighborhood environments providing a potential biological mechanism to explain the association (Browning et al. 2012; Broyles et al. 2012). Similar mechanisms may also operate in childhood adversity.

An adverse fetal environment may also predispose an individual to both type 2 diabetes and depression. There is a J-shaped relationship between birth weight and plasma glucose, insulin concentrations, and type 2 diabetes, while some, but not all, studies have shown that fetal undernutrition is associated with adult depression (Holt et al. 2014). Again, programming of the HPA axis may be one biological mechanism to explain the association (Champaneri et al. 2010).

---

## Consequences of Depression in Diabetes

People with comorbid depression experience worsened diabetes outcomes and poorer quality of life (Goldney et al. 2004; Jacobson et al. 1997; Carper et al. 2014). While it is clear that those with microvascular complications are more likely to develop depression, recent work has also shown that those with depression are more likely to develop complications. In a 10-year cohort study of individuals with childhood-onset diabetes, in addition to longer duration of diabetes and poor glycemic control, the overall proportion of time that an individual was depressed predicted retinopathy severity (Kovacs et al. 1995). Similarly, in a longitudinal study of people with type 2 diabetes, progression to diabetic retinopathy and to proliferative diabetic retinopathy was more likely in those with high depressive symptom scores at both baseline and 6-year follow-up (Roy et al. 2007). Depression may worsen the pain experienced by those with painful peripheral neuropathy (Katona et al. 2005). Poor glycemic control is not the explanation for the increase in microvascular complications seen in people with comorbid depression as studies have not reported a consistent association between depressive symptoms and HbA<sub>1c</sub> (Lustman et al. 2000; Hislop et al. 2008; Aikens et al. 2008). Nevertheless, impaired self-care among people with depression may play a role.

Cardiovascular morbidity and mortality are increased in people with comorbid diabetes and depression (Park et al. 2013); in one study, those with diabetes and depression have an annual mortality rate of 8%, which was 2.5-fold higher than those without either condition (Egede et al. 2005).

---

## Management of People with Diabetes and Depression

A greater awareness of the link between diabetes and depression has led several national and international guideline bodies to recommend action to improve the psychological well-being of people with diabetes (International Diabetes Federation 2012; National Institute for Health and Care Excellence 2015a, b). There is a responsibility for healthcare professionals to identify depression when it occurs and then institute prompt treatment in order to reduce depressive symptoms and to improve self-care, glycemic control, and diabetes outcomes, respectively (Petрак et al. 2015).

## Screening and Diagnosis of Depression

It goes without saying that before treatment can be offered, depression must be recognized and diagnosed. A formal diagnosis of depression requires a time-consuming validated interview, and so this is impractical for routine clinical care. Consequently, quicker and cheaper screening methods are needed to identify those in primary and secondary care with depressive symptoms who should then go forward for a diagnostic interview (Holt and van der Feltz-Cornelis 2012).

Many easy-to-use questionnaires that can be self-completed have been developed for routine use in clinical care, but because of the overlap between symptoms of diabetes and depression, only validated questionnaires should be used for people with diabetes (Roy et al. 2012). The Patient Health Questionnaire-9 (PHQ-9), which contains nine questions, is the most widely used and validated questionnaire in type 2 diabetes, but even this overestimates the prevalence of depression (Fisher et al. 2016). A score of  $\geq 10$  reliably identifies those with major depression in community populations, but a higher cut-off of  $\geq 12$  has been suggested for people with diabetes in order to improve the discrimination between diabetes-related symptoms and depressive symptoms (van Steenbergen-Weijenburg et al. 2010). The Beck Depression Inventory (BDI), the Centre for Epidemiologic Studies Depression Scale (CES-D), and the Hospital Anxiety and Depression Scale (HADS) are other examples of well-validated questionnaires for people with diabetes.

An even simpler approach that can be used by diabetes healthcare professionals is to ask two questions:

- During the past month, have you been bothered by having little interest or pleasure in doing things?
- During the past month, have you been bothered by feeling down, depressed, or hopeless?

If the answer to either is “yes,” the healthcare professional should ask the patient if they want help with this problem. If the answer to this is also “yes,” a diagnostic interview should be undertaken followed by appropriate referral and treatment.

Although diagnosis of depression is necessary to instigate treatment, there is a debate as to whether screening for depression should be undertaken (Holt and van der Feltz-Cornelis 2012). Depression screening in the general population has little or no impact on the detection and management of depression if used alone, and robust clinical pathways are essential to ensure that appropriate treatment can be offered if a diagnosis is made (Gilbody et al. 2008). The importance of this in the context of diabetes was demonstrated in a Dutch randomized controlled trial, which investigated the benefits of depression screening in people with type 2 diabetes (Pouwer et al. 2011). Following screening, although written feedback was provided to both participant and doctor, neither utilization of mental health services nor depression scores improved. A further study from the USA also failed to demonstrate any improvement in depressive symptoms despite a modest increase in mental healthcare utilization (Scollan-Koliopoulos et al. 2012). Low acceptance of screening and subsequent referral to further care by people with diabetes, failure to screen those at highest risk of depression, reluctance by healthcare professionals to undertake screening and treatment, and generally poor quality of depression care in primary care systems may all contribute to these findings (Petрак et al. 2015).

Thus, while there is a strong imperative to identify people with depression, better integration with care pathways is needed, before screening can be wholeheartedly adopted, not least because screening without appropriate follow-up could lead to

harm, by increasing the stigma and discrimination associated with depression and the risk of labeling transient distress as illness (Petрак et al. 2015).

## Treatment of Depression in People with Diabetes

As depression adversely affects psychological well-being and diabetes outcomes, the best treatment approaches focus on both improving depressive symptoms and diabetes self-management. The aim of depression treatment is to achieve complete remission of symptoms with the further goals of improving health-related quality of life and psychosocial functioning (Petрак et al. 2015). Over the last decade, a number of randomized controlled trials have demonstrated the effectiveness of both psychological and pharmacological treatments of depression in people with diabetes (Petрак et al. 2015). Most of these trials have been undertaken in people with type 2 diabetes, and so, there is still a paucity of evidence for type 1 diabetes.

### Psychological Treatment

Psychological interventions are heterogeneous incorporating various techniques (e.g., cognitive behavioral therapy, problem-solving, and psychodynamic), different settings (primary and secondary care), and media (face-to-face, group, web-based, and telephone contacts) (Petрак et al. 2015). Given this level of variability, it is perhaps unsurprising that the effectiveness of interventions differs and comparisons between trials are challenging. Nevertheless, meta-analyses suggest psychological interventions improve depressive symptoms, with a moderate-to-large effect size (standardized mean difference [SMD] ranging from  $-0.14$  to  $-1.47$ ). The effect on glycemic control, however, is more modest with one systematic review reporting a reduced HbA<sub>1c</sub> of  $\sim 0.6\%$  (6 mmol/mol) (Ismail et al. 2004) and another indicating a nonsignificant improvement (SMD from 0.40 to  $-1.40$ ) (Baumeister et al. 2012). Four recent trials on psychological interventions found an improvement in glycemic control (SMD from  $-0.25$  to  $-0.68$ ) (Petрак et al. 2015). Web-based psychological therapies appear less effective than face-to-face contact, particularly for glycemic outcomes (van der Feltz-Cornelis 2013). The most effective psychological interventions combine diabetes self-management education with psychological support (van der Feltz-Cornelis et al. 2010).

### Pharmacotherapy

There are several classes of effective and well-tolerated antidepressants, and these form an integral component of depression management. Randomized clinical trials in people with diabetes have been undertaken for only a relatively small group of antidepressants, including nortriptyline, fluoxetine, bupropion, sertraline, paroxetine, and citalopram (Petрак et al. 2015); however, these trials show that these

antidepressants improve depressive symptoms to a similar extent in people with diabetes and the general population. All antidepressants studied appear to have similar efficacy, and as long as adequate doses are used, the effect sizes are  $-0.61$  SMD (Baumeister et al. 2012). However, there are gaps in our evidence base, with regard to glycemic control and the medium- and long-term sustainability of the pharmacological interventions after treatment cessation. Furthermore, a number of new antidepressants have recently been approved, including vilazodone, vortioxetine, and levomilnacipran, which have not been formally assessed in people with diabetes.

Given the comparable effectiveness, the treatment of choice depends largely on the side effect profile, patient preference, and individual response. Selective serotonin reuptake inhibitors (SSRIs) are widely regarded as first choice agents, because they are less cardiotoxic than the older tricyclic antidepressants and are safer in overdose.

Some antidepressants, including mirtazapine, paroxetine, and some tricyclic antidepressants, may cause unwanted weight gain (Serretti and Mandelli 2010), while bupropion, which is available in the USA but not in Europe, is associated with weight loss.

Several antidepressants may interact with oral hypoglycemic agents through inhibition of the cytochrome P450 3A4 and 2C9 isoenzyme. For example, the use of fluoxetine may potentiate the effect of sulfonylureas precipitating hypoglycemia (Musselman et al. 2003).

Antidepressant treatment should be continued at an adequate dose for at least 4–6 months after complete remission of depressive symptoms to reduce the risk of relapse and recurrence. This is particularly important in people with diabetes, in whom the risk of relapse and persistence of symptoms is greater than the general population.

Clinical trials demonstrate that SSRIs lead to a modest improvement in glycemic control (SMD  $-0.38$ ), but there is a mixed effect on glycemic control with other antidepressants ranging from hyperglycemic effects with tricyclic antidepressant medications to euglycemic or slightly hypoglycemic effects with serotonin-noradrenaline reuptake inhibitors. The diversity of effect implies that any finding of improved glycemic control with individual antidepressants should not be extrapolated to other untried antidepressants (Petрак et al. 2015).

The treatment of depression may lead to a change in the patient's behavior and routine requiring a change in diabetes self-management. For example, should the patient's appetite improve, more insulin may be required; by contrast, if the patient becomes more physically active, less may be needed.

## Models of Care

Many healthcare systems are poorly equipped to manage comorbidity, particularly where this involves mental and physical illness. The Cartesian split of mind and body affects the delivery of care, leading healthcare professionals to consider one



or other illness rather than making holistic decisions. In order to overcome this, the late Wayne Katon and colleagues in Seattle pioneered a model of care, known as “Collaborative Care” (Katon et al. 2010). This model encourages interdisciplinary cooperation between healthcare providers and shared decision making to facilitate appropriate provision of evidence-based treatment options, regular follow-up, self-management training, and support for people with comorbid diabetes and depression. The first study of this model showed improvements in depression symptoms but no change in glycemic control (Katon et al. 2004); however, in later studies, greater attention was paid to diabetes and blood pressure interventions, leading to improved biomedical outcomes as well as improved depressive symptoms (Katon et al. 2010). These models of care are also highly cost-effective (Simon et al. 2001, 2007).

---

## Cognitive Function

Cognitive function can be defined as an intellectual process by which one becomes aware of, perceives, or comprehends ideas. It involves aspects of perception, thinking, reasoning, and remembering. Given the multifaceted nature of cognition, a full assessment of cognitive functioning requires a battery of psychometric tests to obtain an overview of an individual’s thinking skills. These tests assess how a person processes information, reasons, and learns in different ways. Cognitive function may be impaired globally or specific components of cognitive function may be affected.

---

## Diabetes and Cognition

As cognitive and affective processes occur in highly linked regions of the brain, it is unsurprising that people with diabetes also experience cognitive deficits. These are relatively modest in most individuals but particularly affect general intelligence, psychomotor speed, and mental flexibility; on average performance in these domains is 0.3–0.7 standard deviations below the population mean (van den Berg et al. 2009; Brands et al. 2005; Palta et al. 2014) and has been likened to the change in cognitive function experienced after a 6–8 h jetlag (Fig. 1). The effects of diabetes on the brain appear to be age related with children and older adults being most vulnerable, with effects being attributable to both hypoglycemia and chronic hyperglycemia.

## Cognitive Dysfunction in Children and Adolescents

The age of onset of diabetes is a major determining factor for its effect on cognitive function in children. In those diagnosed before the age of 7 years, there is an

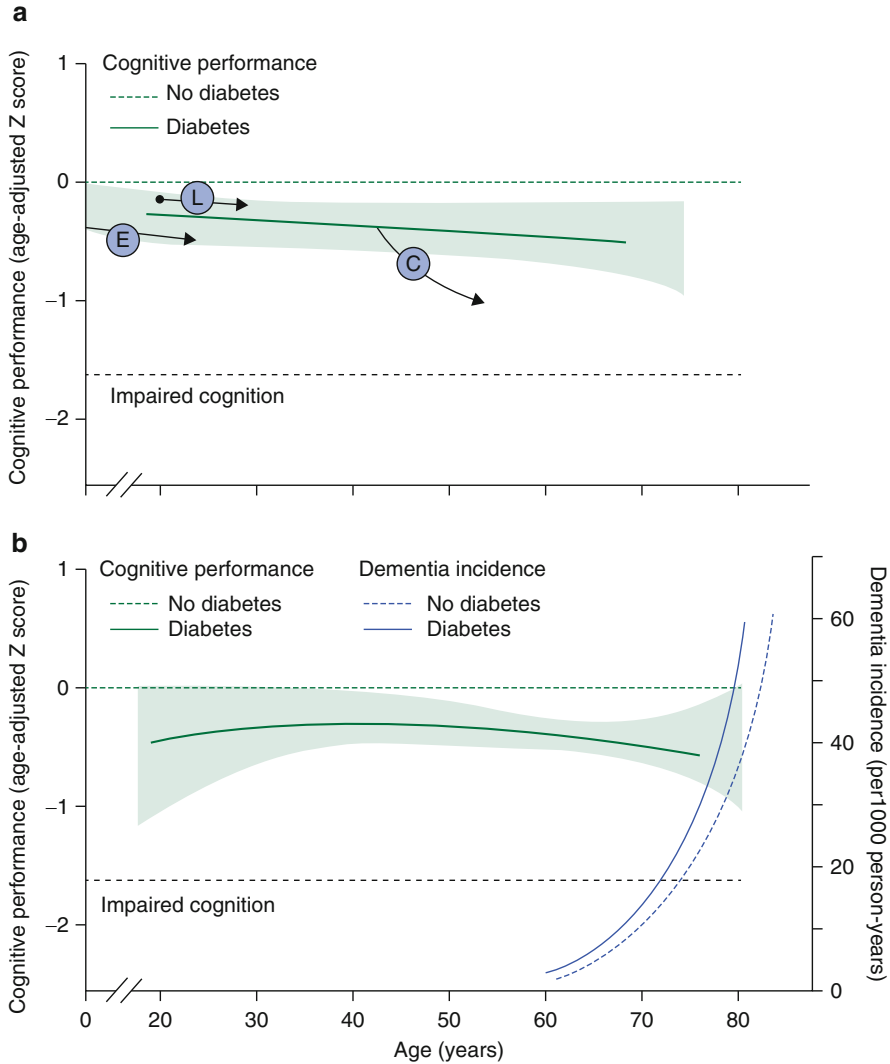

**Fig. 1** Trajectories of cognitive dysfunction in type 1 and type 2 diabetes. **(a)** Cognitive dysfunction in people with type 1 diabetes. Cognitive decrements can be detected soon after onset of diabetes, often in childhood. The width of the shaded area indicates the uncertainty of the estimates, which is larger in older age groups (>65 years for type 1, >80 years for type 2 diabetes) because of the small number of studies. In young adults with type 1 diabetes, cognitive decrements are largest in individuals with an early diabetes onset (black arrow E) and smaller in individuals with a later onset (arrow L). Estimates of the diabetes-associated decrements do not clearly increase with age, consistent with slow progression of the decrements over time. However, some individuals, particularly those with severe microvascular complications (arrow C), might show accelerated decline. **(b)** In people with type 2 diabetes, estimates of mean cognitive decrements are likewise mostly independent of age. By contrast, the incidence of dementia (blue lines), which is increased in people with diabetes, is strongly dependent on age. (Reprinted from Koekkoek et al. (2015). Copyright (2015), with permission from Elsevier)

increased risk of developing cognitive impairment across a range of cognitive domains, including attention, mental flexibility, psychomotor efficiency, learning, memory, problem-solving, and overall intelligence, and which start to be apparent within 2–3 years of diagnosis (Biessels et al. 2008; Gaudieri et al. 2008; Northam et al. 2001, 2006; Hershey et al. 2004). For children diagnosed after this age, the effect is much more modest and is confined primarily to overall intelligence and speed-related tasks, particularly those with a visual-perceptual aspect (Gaudieri et al. 2008). The cognitive impairment seen in children diagnosed before the age of 7 years persists into adulthood and manifests as lower IQ scores and slower information processing (Ferguson et al. 2005).

Academic achievement is lower in children with diabetes, irrespective of the age of diagnosis, but this could relate to school absences or hypoglycemia interfering with learning as much as a direct effect on the developing brain (McCarthy et al. 2003). However, there is evidence from older studies that severe hypoglycemia causes neuropsychological deficits, particularly in children whose onset of diabetes occurred below the age of 6 years (Ryan et al. 1985; Rovet and Ehrlich 1999). Part of the problem is that younger children may not be able to describe their hypoglycemic symptoms, thereby increasing the likelihood of prolonged and severe hypoglycemia. Some support for the hypoglycemia hypothesis comes from a meta-analysis of data from 441 children with recurrent severe hypoglycemia and 560 children without recurrent severe hypoglycemia (Blasetti et al. 2011). This study found that those with recurrent severe hypoglycemia had a modestly reduced performance in the domains of intelligence, language, and memory and learning but motor speed was unaffected (Blasetti et al. 2011). This effect appears to be limited to children, because there was no difference in the cognitive function in adults with type 1 diabetes in the Diabetes Control and Complications Trial with and without a history of severe hypoglycemia after an 18-year follow-up period (Jacobson et al. 2007). Similarly, the Action to Control Cardiovascular Risk in Diabetes-Memory in Diabetes (ACCORD-MIND) study, which recruited adults with type 2 diabetes, found no difference in cognitive function after 20-month and 40-month follow-up, respectively, between those treated intensively compared with standard care despite a threefold increase in the rates of hypoglycemia (Launer et al. 2011).

## **Cognitive Dysfunction in Adults with Diabetes**

Adults with type 1 diabetes show modest nonprogressive cognitive deficits in measures of intelligence, attention, psychomotor speed, cognitive flexibility, and visual perception, but measures of language, learning, and memory are unaffected despite long duration of diabetes (Brands et al. 2005, 2006). With the exception of “crystallized intelligence,” the affected domains require a rapid response indicating that diabetes affects mental agility rather than accuracy.

These changes are accompanied by structural changes that are characterized by reduced gray matter volumes in the frontal lobe and the adjacent supramarginal and postcentral gyri (Hughes et al. 2013). These MRI alterations have been linked to

disrupted integrity of fiber tracts connecting the main cortical areas of the brain (Koekkoek et al. 2015). Functional studies have demonstrated altered cerebral perfusion with both decreased and increased blood flow (Kodl et al. 2008; Franc et al. 2011; van Duinkerken et al. 2012).

Adults with type 2 diabetes also show mild cognitive deficits affecting memory, processing speed, and executive function, which may lead to the individual to be less able to process unstructured information (van den Berg et al. 2009; Palta et al. 2014). Interestingly, similar deficits are also present in people with newly diagnosed type 2 diabetes and impaired glucose regulation as well as those with features of the metabolic syndrome (Crichton et al. 2012; Lamport et al. 2009; Ruis et al. 2009). Type 2 diabetes is also associated with structural changes in the brain, characterized by a loss of gray matter in the medial temporal, anterior cingulate, and medial frontal lobes, while white matter is lost in the frontal and temporal regions, respectively (Moran et al. 2013).

The mechanisms underlying these changes are not fully understood although studies have not consistently demonstrated an association with cerebral small vessel disease (Koekkoek et al. 2015). The link between glycemic control and cognitive dysfunction in adults with diabetes is less obvious than for children. As previously described, hypoglycemia does not appear to be a major risk factor for cognitive decline in young- and middle-aged adults with diabetes, but hyperglycemia appears to be more important, at least in the case of type 1 diabetes. A recent meta-analysis found a weak negative association between HbA<sub>1c</sub> and cognitive function, with HbA<sub>1c</sub> explaining at most 10–15% of the variance in cognitive function (Geijselaers et al. 2015).

The presence of microvascular complications, especially retinopathy and nephropathy, is associated with accelerated cognitive decline (Ryan et al. 2003; Jacobson et al. 2011). Cardiovascular disease and its risk factors are also associated with cognitive decline as they are in the general population, but whether there is any specific interaction with diabetes is uncertain (Koekkoek et al. 2015; Ryan et al. 2003).

---

## Dementia

The term dementia encompasses a broad category of brain disorders that lead to a gradual and progressive decline in cognitive function to the extent that an individual's ability to function on a day-to-day basis is impaired. There are different types of dementia of which the most common are Alzheimer's disease (50–70% of cases) and vascular dementia (up to 25%). Other causes of dementia are shown in Table 3. There has been a rapid increase in the prevalence of dementia in recent years, with a global prevalence of 22.7 million in 2015. The World Alzheimer Report predicts the prevalence of dementia to rise to 38.5 million by 2030 and 131.5 million by 2050. This increase is largely being driven by an aging population as the prevalence rises from 1.4% in men and 1.9% in women aged 60–64 years to 33.4% in men and 48.3% in women aged >90 years. In 2013, approximately 1.7 million people died as a result of dementia.

**Table 3** Causes of dementia in people with diabetes

Alzheimer's disease	62%
Vascular dementia	17%
Mixed	10%
Lewy body dementia	4%
Parkinson's disease	2%
Frontotemporal	2%
Others	3%

## Diabetes and Dementia

The rate of cognitive decline in older individuals with type 2 diabetes appears to be up to twofold quicker than the general population, and a number of studies have indicated that the risk of dementia is increased by approximately 50% in people with diabetes (Cheng et al. 2012). The commonest cause of dementia in people with diabetes is Alzheimer's disease, which is increased by 46%, while vascular dementia is increased 2.38-fold (Cheng et al. 2012). It is estimated that the diabetes-attributable risk of dementia is 6–7%; in other words, 1 in 15 cases of dementia is attributable to diabetes (Koekkoek et al. 2015). An increased risk of dementia has also been reported in people with prediabetes and metabolic syndrome (Crichton et al. 2012). Diabetes worsens the outcome for people with dementia and is associated with 90% increase in mortality compared with those without diabetes (Zilkens et al. 2013).

Part of the explanation for this increased incidence of dementia risk stems from a higher prevalence of risk factors among people with diabetes (Table 4). Many of these cardiovascular risk cluster in people with diabetes and those at risk of diabetes. Interestingly, glycemia per se appears to have little impact on the risk (Geijselaers et al. 2015). Only one study has linked elevated HbA<sub>1c</sub> with the risk of dementia and only in those with markedly elevated levels (10–12%, 86–108 mmol/mol). No association between fasting or postprandial glucose and measures of glucose variability with dementia has been found.

Unlike in younger adults, recurrent hypoglycemia is an important risk factor for cognitive decline in patients with dementia (Whitmer et al. 2009; Punthakee et al. 2012). In a retrospective study of 16,667 older people with diabetes, a history of one, two, and three or more severe hypoglycemic episodes increased the risk of dementia by 26%, 80%, and 94%, respectively, independent of glycemic control, medications, and other comorbidities (Whitmer et al. 2009). The relationship, however, appears to be bidirectional as cognitive dysfunction increases risk of hypoglycemia, thereby, creating a vicious cycle.

Impaired insulin signaling in the brain may also play a role in the development of Alzheimer's disease (Li et al. 2015). Briefly, the pathology of Alzheimer's disease is characterized by the deposition of  $\beta$ -amyloid plaques and tangles in the brain (Turner et al. 2003; Niedowicz et al. 2011).  $\beta$ -amyloid is derived from the

**Table 4** Risk factors for Alzheimer's disease and vascular dementia

Alzheimer's disease	Vascular dementia
Dyslipidemia	Dyslipidemia
Smoking	Smoking
Hypertension	Hypertension
Obesity	Obesity
Physical inactivity	Atrial fibrillation
Depression	Previous coronary heart disease, stroke of transient ischemic event
Alcohol	
Head injury	

cleavage of amyloid precursor protein, an extracellular protein which is critical to neuron growth, survival, and post-injury repair. The formation of  $\beta$ -amyloid is regulated with several genes but is increased in aging and by obesity, and less prudent diet (Niedowicz et al. 2011). Insulin inhibits the production and accumulation of  $\beta$ -amyloid, and so in situations where there is insulin deficiency or impaired action,  $\beta$ -amyloid accumulates (Li et al. 2015). Supporting this hypothesis is the observation of reduced brain insulin and its receptor in people with Alzheimer's disease.

---

## Clinical Implications of Dementia in People with Diabetes

### Prevention of Dementia

Several large randomized controlled trials in both type 1 diabetes and type 2 diabetes have investigated whether improved glycemic control can reduce the risk of dementia. To date, no difference in the rate of cognitive decline, cognitive performance, or incidence of dementia has been seen in those with tighter glycemic control (Jacobson et al. 2007; Launer et al. 2011; Koekkoek et al. 2012; de Galan et al. 2009). The ACCORD-MIND study also assessed whether better blood pressure and lipid control could improve cognition but again, no benefit was seen in those treated with a combination of statin and fibrate while intensive blood pressure lowering actually accelerated brain atrophy (Williamson et al. 2014).

### Diagnosis of Dementia

Once dementia develops, the person's ability to self-manage their diabetes progressively deteriorates. Exercise and diet appear to be particularly affected, but the real danger lies in the increased risk of adverse events in people taking hypoglycemic

drugs. The risk of hypoglycemia is exacerbated further because dementia may impair language and lead to disorientation and personality changes, all of which may mimic the symptoms of hypoglycemia (Sinclair et al. 2010). When lack of engagement with self-management occurs in older people, clinicians should consider cognitive dysfunction as a cause.

A risk score which includes age, microvascular disease, diabetic foot, cerebrovascular disease, cardiovascular disease, acute metabolic events, depression, and education has been developed to help predict the risk of developing dementia. In a prospective study over 10 years, the risk of developing dementia was 5.3% in those with the lowest score compared with 73.3% for the top scores (Exalto et al. 2013). Other authors have advocated the use of the easy-to-perform Mini-Cog test as a simple screening tool for dementia. This test has a sensitivity of 86.4% and a specificity of 91.1% (Sinclair et al. 2013).

A formal diagnosis of dementia involves a combination of history, examination, including tests of mental investigation, and investigation. It is important to obtain corroborating information from a friend or relative who knows the patient well. Unfortunately, the diagnosis is not always straightforward particularly in the early stages, and time may be an important diagnostic tool.

## Treatment of Dementia

A detailed description of the treatment of Alzheimer's disease is beyond the scope of this chapter as treatment is usually initiated in specialist memory clinics. The most commonly used drugs are the acetylcholinesterase inhibitors, such as donepezil, which are licensed for the treatment of mild-to-moderate Alzheimer's disease (Cummins et al. 2015). This class of agents can cause bradycardia and exacerbate symptoms of gastric and duodenal ulcers, precipitate bronchospasm, and may cause convulsions. Dizziness, headache, and nausea are the most common side effects with abdominal disturbance and nightmares being also reported. Because of the cardiovascular effects, they should be used with caution in those whose baseline pulse is <60 beats per minute. An ECG is recommended if the pulse is <70 beats per minute or if it is irregular.

Given the relationship between cerebral insulin action and Alzheimer's disease, the use of several antidiabetes drugs has been examined in people with dementia (Koekkoek et al. 2015; Li et al. 2015). Small studies have suggested that intranasal insulin improves delayed memory and cognitive function (Reger et al. 2008; Craft et al. 2012), but the results of larger ongoing trials of people with Alzheimer's disease, with and without diabetes, are awaited (Koekkoek et al. 2015). Studies of thiazolidinediones have shown mixed effects on cognitive function but a possible benefit has been reported in those whose genotype is APOE- $\epsilon$ 4-negative (Watson et al. 2005; Risner et al. 2006; Gold et al. 2010). Besides insulin, glucagon-like peptide 1 (GLP-1) also appears to play an important role in the control of synaptic plasticity and in some forms of memory formation, and two trials of GLP-1 receptor agonists are ongoing (Li et al. 2015).

## Management of Diabetes in Someone with Dementia

As dementia affects self-management, it is important that glycemic targets are adjusted appropriately taking into account overall health and life expectancy. Several guidelines now recommend HbA<sub>1c</sub> targets of <8.5% (69 mmol/mol) for older, dependent people with dementia (Sinclair et al. 2012). In these individuals, avoidance of symptomatic hypoglycemia is more important than tight glycemic control, which may reduce the quality of life. Glycemic targets should be regularly reviewed and medications should be prescribed as appropriate.

Many older people with diabetes and dementia are overtreated with multiple drugs. In a retrospective cohort study of 15,880 people with type 2 diabetes and dementia from the Veterans Affairs Healthcare System, 52% of participants had an HbA<sub>1c</sub> <7% (53 mmol/mol), and within this group, 75% were treated either with sulfonylureas, insulin, or both placing them at a high risk of hypoglycemia (Thorpe et al. 2015). Declining weight, malnutrition, and frailty may lead to a reduced need for antidiabetes medications, and these have been safely withdrawn in several studies (Sjoblom et al. 2008) without a deterioration of their glycemic control (Abdelhafiz et al. 2014). Drugs with a lower risk of hypoglycemia should be preferentially used.

---

## Conclusions

This chapter has highlighted some of the many and various ways in which diabetes interacts with the brain. It is clear that these connections can have a major impact on diabetes outcomes, and health professionals who work with people with diabetes, require good knowledge and awareness of these issues to be able to provide optimal care. There is, clearly, also a great need for closer working between diabetes services and mental health services while further research on these topics is also required.

**Acknowledgments** Richard Holt has received fees for lecturing and consultancy from the following companies: Eli Lilly, Janssen, Lundbeck, Novo Nordisk, Novartis, Otsuka, Sanofi, Sunovion, Takeda, and MSD.

---

## References

- Abdelhafiz AH, Chakravorty P, Gupta S, Haque A, Sinclair AJ. Can hypoglycaemic medications be withdrawn in older people with type 2 diabetes? *Int J Clin Pract.* 2014;68(6):790–2.
- Adriaanse MC, Snoek FJ, Dekker JM, Spijkerman AM, Nijpels G, Twisk JW, et al. No substantial psychological impact of the diagnosis of type 2 diabetes following targeted population screening: the Hoorn Screening Study. *Diabet Med.* 2004;21(9):992–8.
- Aikens JE, Perkins DW, Piette JD, Lipton B. Association between depression and concurrent type 2 diabetes outcomes varies by diabetes regimen. *Diabet Med.* 2008;25(11):1324–9.
- Ali S, Stone MA, Peters JL, Davies MJ, Khunti K. The prevalence of co-morbid depression in adults with type 2 diabetes: a systematic review and meta-analysis. *Diabet Med.* 2006;23(11):1165–73.



- American Psychiatric Association. Diagnostic and statistical manual of mental disorders. 4th ed. Washington, DC: American Psychiatric Association; 2005.
- Anderson RJ, Freedland KE, Clouse RE, Lustman PJ. The prevalence of comorbid depression in adults with diabetes: a meta-analysis. *Diabetes Care*. 2001;24(6):1069–78.
- Barnard KD, Skinner TC, Peveler R. The prevalence of co-morbid depression in adults with type 1 diabetes: systematic literature review. *Diabet Med*. 2006;23(4):445–8.
- Barnard K, Peveler RC, Holt RI. Antidepressant medication as a risk factor for type 2 diabetes and impaired glucose regulation: systematic review. *Diabetes Care*. 2013;36(10):3337–45.
- Baumeister H, Hutter N, Bengel J. Psychological and pharmacological interventions for depression in patients with diabetes mellitus and depression. *Cochrane Database Syst Rev*. 2012;12:CD008381.
- Biessels GJ, Deary IJ, Ryan CM. Cognition and diabetes: a lifespan perspective. *Lancet Neurol*. 2008;7(2):184–90.
- Blasetti A, Chiuri RM, Tocco AM, Di GC, Mattei PA, Ballone E, et al. The effect of recurrent severe hypoglycemia on cognitive performance in children with type 1 diabetes: a meta-analysis. *J Child Neurol*. 2011;26(11):1383–91.
- Brands AM, Biessels GJ, de Haan EH, Kappelle LJ, Kessels RP. The effects of type 1 diabetes on cognitive performance: a meta-analysis. *Diabetes Care*. 2005;28(3):726–35.
- Brands AM, Kessels RP, Hoogma RP, Henselmans JM, van der Beek Boter JW, Kappelle LJ, et al. Cognitive performance, psychological well-being, and brain magnetic resonance imaging in older patients with type 1 diabetes. *Diabetes*. 2006;55(6):1800–6.
- Brenner AB, Zimmerman MA, Bauermeister JA, Caldwell CH. The physiological expression of living in disadvantaged neighborhoods for youth. *J Youth Adolesc*. 2013;42(6):792–806.
- Browning CR, Cagney KA, Iveniuk J. Neighborhood stressors and cardiovascular health: crime and C-reactive protein in Dallas, USA. *Soc Sci Med*. 2012;75(7):1271–9.
- Broyles ST, Staiano AE, Drazba KT, Gupta AK, Sothorn M, Katzmarzyk PT. Elevated C-reactive protein in children from risky neighborhoods: evidence for a stress pathway linking neighborhoods and inflammation in children. *PLoS One*. 2012;7(9):e45419.
- Carney RM, Freedland KE. Depression, mortality, and medical morbidity in patients with coronary heart disease. *Biol Psychiatry*. 2003;54(3):241–7.
- Carper MM, Traeger L, Gonzalez JS, Wexler DJ, Psaros C, Safren SA. The differential associations of depression and diabetes distress with quality of life domains in type 2 diabetes. *J Behav Med*. 2014;37(3):501–10.
- Champaneri S, Wand GS, Malhotra SS, Casagrande SS, Golden SH. Biological basis of depression in adults with diabetes. *Curr Diab Rep*. 2010;10(6):396–405.
- Cheng G, Huang C, Deng H, Wang H. Diabetes as a risk factor for dementia and mild cognitive impairment: a meta-analysis of longitudinal studies. *Intern Med J*. 2012;42(5):484–91.
- Cleal B, Panton UH, Willaing I, Holt RI. Diabetes and depression in Denmark 1996–2010: national data stratified by occupational status and annual income. *Diabet Med*. 2017;34(1):108–14.
- Craft S, Baker LD, Montine TJ, Minoshima S, Watson GS, Claxton A, et al. Intranasal insulin therapy for Alzheimer disease and amnesic mild cognitive impairment: a pilot clinical trial. *Arch Neurol*. 2012;69(1):29–38.
- Crichton GE, Elias MF, Buckley JD, Murphy KJ, Bryan J, Frisardi V. Metabolic syndrome, cognitive performance, and dementia. *J Alzheimers Dis*. 2012;30(Suppl 2):S77–87.
- Cummings JL, Isaacson RS, Schmitt FA, Velting DM. A practical algorithm for managing Alzheimer's disease: what, when, and why? *Ann Clin Transl Neurol*. 2015;2(3):307–23.
- Dantzer R, O'Connor JC, Freund GG, Johnson RW, Kelley KW. From inflammation to sickness and depression: when the immune system subjugates the brain. *Nat Rev Neurosci*. 2008;9(1):46–56.
- de Galan BE, Zoungas S, Chalmers J, Anderson C, Dufouil C, Pillai A, et al. Cognitive function and risks of cardiovascular disease and hypoglycaemia in patients with type 2 diabetes: the Action in Diabetes and Vascular Disease: Preterax and Diamicon Modified Release Controlled Evaluation (ADVANCE) trial. *Diabetologia*. 2009;52(11):2328–36.

- de Groot M, Anderson R, Freedland KE, Clouse RE, Lustman PJ. Association of depression and diabetes complications: a meta-analysis. *Psychosom Med.* 2001;63(4):619–30.
- de Vet E, de Ridder DT, de Wit JB. Environmental correlates of physical activity and dietary behaviours among young people: a systematic review of reviews. *Obes Rev.* 2011;12(5):e130–42.
- Do DP, Diez Roux AV, Hajat A, Auchincloss AH, Merkin SS, Ranjit N, et al. Circadian rhythm of cortisol and neighborhood characteristics in a population-based sample: the Multi-Ethnic Study of Atherosclerosis. *Health Place.* 2011;17(2):625–32.
- Dulin-Keita A, Casazza K, Fernandez JR, Goran MI, Gower B. Do neighbourhoods matter? Neighbourhood disorder and long-term trends in serum cortisol levels. *J Epidemiol Community Health.* 2012;66(1):24–9.
- Egede LE, Nietert PJ, Zheng D. Depression and all-cause and coronary heart disease mortality among adults with and without diabetes. *Diabetes Care.* 2005;28(6):1339–45.
- Exalto LG, Biessels GJ, Karter AJ, Huang ES, Katon WJ, Minkoff JR, et al. Risk score for prediction of 10 year dementia risk in individuals with type 2 diabetes: a cohort study. *Lancet Diabetes Endocrinol.* 2013;1(3):183–90.
- Ferguson SC, Blane A, Wardlaw J, Frier BM, Perros P, McCrimmon RJ, et al. Influence of an early-onset age of type 1 diabetes on cerebral structure and cognitive function. *Diabetes Care.* 2005;28(6):1431–7.
- First MB, Spitzer RL, Gibbon M, Williams JB. Structured Clinical Interview for DSM-IV-TR Axis I Disorders, research version, patient edition. (SCID-I/P). New York: Biometrics Research, New York State Psychiatric Institute; 2002.
- Fisher L, Glasgow RE, Strycker LA. The relationship between diabetes distress and clinical depression with glycemic control among patients with type 2 diabetes. *Diabetes Care.* 2010;33(5):1034–6.
- Fisher L, Hessler DM, Polonsky WH, Masharani U, Peters AL, Blumer I, et al. Prevalence of depression in type 1 diabetes and the problem of over-diagnosis. *Diabet Med.* 2016;33(11):1590–7. <https://doi.org/10.1111/dme.12973>
- Franc DT, Kodl CT, Mueller BA, Muetzel RL, Lim KO, Seaquist ER. High connectivity between reduced cortical thickness and disrupted white matter tracts in long-standing type 1 diabetes. *Diabetes.* 2011;60(1):315–9.
- Gangwisch JE. Epidemiological evidence for the links between sleep, circadian rhythms and metabolism. *Obes Rev.* 2009;10(Suppl 2):37–45.
- Gaudieri PA, Chen R, Greer TF, Holmes CS. Cognitive function in children with type 1 diabetes: a meta-analysis. *Diabetes Care.* 2008;31(9):1892–7.
- Geijselaers SL, Sep SJ, Stehouwer CD, Biessels GJ. Glucose regulation, cognition, and brain MRI in type 2 diabetes: a systematic review. *Lancet Diabetes Endocrinol.* 2015;3(1):75–89.
- Gilbody S, Sheldon T, House A. Screening and case-finding instruments for depression: a meta-analysis. *CMAJ.* 2008;178(8):997–1003.
- Gold M, Alderton C, Zvartau-Hind M, Egginton S, Saunders AM, Irizarry M, et al. Rosiglitazone monotherapy in mild-to-moderate Alzheimer's disease: results from a randomized, double-blind, placebo-controlled phase III study. *Dement Geriatr Cogn Disord.* 2010;30(2):131–46.
- Goldney RD, Phillips PJ, Fisher LJ, Wilson DH. Diabetes, depression, and quality of life: a population study. *Diabetes Care.* 2004;27(5):1066–70.
- Gonzalez JS, Peyrot M, McCarl LA, Collins EM, Serpa L, Mimiaga MJ, et al. Depression and diabetes treatment nonadherence: a meta-analysis. *Diabetes Care.* 2008;31(12):2398–403.
- Hermanns N, Kulzer B, Krichbaum M, Kubiak T, Haak T. Affective and anxiety disorders in a German sample of diabetic patients: prevalence, comorbidity and risk factors. *Diabet Med.* 2005;22(3):293–300.
- Hermanns N, Scheff C, Kulzer B, Weyers P, Pauli P, Kubiak T, et al. Association of glucose levels and glucose variability with mood in type 1 diabetic patients. *Diabetologia.* 2007;50(5):930–3.
- Hershey T, Lillie R, Sadler M, White NH. A prospective study of severe hypoglycemia and long-term spatial memory in children with type 1 diabetes. *Pediatr Diabetes.* 2004;5(2):63–71.

- Hislop AL, Fegan PG, Schlaeppli MJ, Duck M, Yeap BB. Prevalence and associations of psychological distress in young adults with type 1 diabetes. *Diabet Med*. 2008;25(1):91–6.
- Ho N, Sommers MS, Lucki I. Effects of diabetes on hippocampal neurogenesis: links to cognition and depression. *Neurosci Biobehav Rev*. 2013;37(8):1346–62.
- Holt RI, Katon WJ. Dialogue on diabetes and depression: dealing with the double burden of comorbidity. *J Affect Disord*. 2012;142:S1–3.
- Holt RI, van der Feltz-Cornelis CM. Key concepts in screening for depression in people with diabetes. *J Affect Disord*. 2012;142:S72–9.
- Holt RI, de Groot M, Golden SH. Diabetes and depression. *Curr Diab Rep*. 2014;14(6):491.
- Hughes TM, Ryan CM, Aizenstein HJ, Nunley K, Gianaros PJ, Miller R, et al. Frontal gray matter atrophy in middle aged adults with type 1 diabetes is independent of cardiovascular risk factors and diabetes complications. *J Diabetes Complicat*. 2013;27(6):558–64.
- International Diabetes Federation. Global guideline for type 2 diabetes. 2012. <http://www.idf.org/guideline-type-2-diabetes>. Last accessed 17 Sept 2016.
- Ismail K, Winkley K, Rabe-Hesketh S. Systematic review and meta-analysis of randomised controlled trials of psychological interventions to improve glycaemic control in patients with type 2 diabetes. *Lancet*. 2004;363(9421):1589–97.
- Jacobson AM, de Groot M, Samson JA. The effects of psychiatric disorders and symptoms on quality of life in patients with type I and type II diabetes mellitus. *Qual Life Res*. 1997;6(1):11–20.
- Jacobson AM, Musen G, Ryan CM, Silvers N, Cleary P, Waberski B, et al. Long-term effect of diabetes and its treatment on cognitive function. *N Engl J Med*. 2007;356(18):1842–52.
- Jacobson AM, Ryan CM, Cleary PA, Waberski BH, Weinger K, Musen G, et al. Biomedical risk factors for decreased cognitive functioning in type 1 diabetes: an 18 year follow-up of the Diabetes Control and Complications Trial (DCCT) cohort. *Diabetologia*. 2011;54(2):245–55.
- Karb RA, Elliott MR, Dowd JB, Morenoff JD. Neighborhood-level stressors, social support, and diurnal patterns of cortisol: the Chicago Community Adult Health Study. *Soc Sci Med*. 2012;75(6):1038–47.
- Katon WJ, Von Korff M, Lin EH, Simon G, Ludman E, Russo J, et al. The Pathways Study: a randomized trial of collaborative care in patients with diabetes and depression. *Arch Gen Psychiatry*. 2004;61(10):1042–9.
- Katon WJ, Lin EH, Von Korff M, Ciechanowski P, Ludman EJ, Young B, et al. Collaborative care for patients with depression and chronic illnesses. *N Engl J Med*. 2010;363(27):2611–20.
- Katona C, Peveler R, Dowrick C, Wessely S, Feinmann C, Gask L, et al. Pain symptoms in depression: definition and clinical significance. *Clin Med*. 2005;5(4):390–5.
- Knol MJ, Twisk JW, Beekman AT, Heine RJ, Snoek FJ, Pouwer F. Depression as a risk factor for the onset of type 2 diabetes mellitus. A meta-analysis. *Diabetologia*. 2006;49(5):837–45.
- Kodl CT, Franc DT, Rao JP, Anderson FS, Thomas W, Mueller BA, et al. Diffusion tensor imaging identifies deficits in white matter microstructure in subjects with type 1 diabetes that correlate with reduced neurocognitive function. *Diabetes*. 2008;57(11):3083–9.
- Koekkoek PS, Ruis C, van den Donk M, Biessels GJ, Gorter KJ, Kappelle LJ, et al. Intensive multifactorial treatment and cognitive functioning in screen-detected type 2 diabetes – the ADDITION-Netherlands study: a cluster-randomized trial. *J Neurol Sci*. 2012;314(1–2):71–7.
- Koekkoek PS, Kappelle LJ, van den Berg E, Rutten GE, Biessels GJ. Cognitive function in patients with diabetes mellitus: guidance for daily care. *Lancet Neurol*. 2015;14(3):329–40.
- Kovacs M, Mukerji P, Drash A, Iyengar S. Biomedical and psychiatric risk factors for retinopathy among children with IDDM. *Diabetes Care*. 1995;18(12):1592–9.
- Lamport DJ, Lawton CL, Mansfield MW, Dye L. Impairments in glucose tolerance can have a negative impact on cognitive function: a systematic research review. *Neurosci Biobehav Rev*. 2009;33(3):394–413.
- Launer LJ, Miller ME, Williamson JD, Lazar RM, Gerstein HC, Murray AM, et al. Effects of intensive glucose lowering on brain structure and function in people with type 2 diabetes (ACCORD MIND): a randomised open-label substudy. *Lancet Neurol*. 2011;10(11):969–77.

- Li C, Ford ES, Strine TW, Mokdad AH. Prevalence of depression among U.S. adults with diabetes: findings from the 2006 behavioral risk factor surveillance system. *Diabetes Care*. 2008;31(1):105–7.
- Li X, Song D, Leng SX. Link between type 2 diabetes and Alzheimer's disease: from epidemiology to mechanism and treatment. *Clin Interv Aging*. 2015;10:549–60.
- Lustman PJ, Anderson RJ, Freedland KE, de Groot M, Carney RM, Clouse RE. Depression and poor glycemic control: a meta-analytic review of the literature. *Diabetes Care*. 2000;23(7):934–42.
- Lyoo IK, Yoon SJ, Musen G, Simonson DC, Weinger K, Bolo N, et al. Altered prefrontal glutamate-glutamine-gamma-aminobutyric acid levels and relation to low cognitive performance and depressive symptoms in type 1 diabetes mellitus. *Arch Gen Psychiatry*. 2009;66(8):878–87.
- Matcham F, Rayner L, Steer S, Hotopf M. The prevalence of depression in rheumatoid arthritis: a systematic review and meta-analysis. *Rheumatology (Oxford)*. 2013;52(12):2136–48.
- McCarthy AM, Lindgren S, Mengeling MA, Tsalikian E, Engvall J. Factors associated with academic achievement in children with type 1 diabetes. *Diabetes Care*. 2003;26(1):112–7.
- McMartin SE, Jacka FN, Colman I. The association between fruit and vegetable consumption and mental health disorders: evidence from five waves of a national survey of Canadians. *Prev Med*. 2013;56(3–4):225–30.
- Mezuk B, Eaton WW, Albrecht S, Golden SH. Depression and type 2 diabetes over the lifespan: a meta-analysis. *Diabetes Care*. 2008;31(12):2383–90.
- Mitchell AJ, Malone D, Doebbeling CC. Quality of medical care for people with and without comorbid mental illness and substance misuse: systematic review of comparative studies. *Br J Psychiatry*. 2009;194(6):491–9.
- Mommersteeg PM, Herr R, Pouwer F, Holt RI, Loerbroeks A. The association between diabetes and an episode of depressive symptoms in the 2002 World Health Survey: an analysis of 231,797 individuals from 47 countries. *Diabet Med*. 2013;30(6):e208–14.
- Moran C, Phan TG, Chen J, Blizzard L, Beare R, Venn A, et al. Brain atrophy in type 2 diabetes: regional distribution and influence on cognition. *Diabetes Care*. 2013;36(12):4036–42.
- Murray CJ, Lopez AD. Alternative projections of mortality and disability by cause 1990–2020: global burden of disease study. *Lancet*. 1997;349(9064):1498–504.
- Musselman DL, Betan E, Larsen H, Phillips LS. Relationship of depression to diabetes types 1 and 2: epidemiology, biology, and treatment. *Biol Psychiatry*. 2003;54(3):317–29.
- National Institute for Health and Care Excellence. Type 1 diabetes in adults: diagnosis and management, NICE guidelines (NG17). 2015a. <https://www.nice.org.uk/guidance/ng17>. Last accessed 17 Sept 2016.
- National Institute for Health and Care Excellence. Type 2 diabetes in adults: management. NICE guidelines (NG28). 2015b. <https://www.nice.org.uk/guidance/ng28>. Last accessed 17 Sept 2016.
- Nefs G, Pouwer F, Denollet J, Pop V. The course of depressive symptoms in primary care patients with type 2 diabetes: results from the Diabetes, Depression, Type D Personality Zuidoost-Brabant (DiaDDZoB) Study. *Diabetologia*. 2012;55(3):608–16.
- Niedowicz DM, Nelson PT, Murphy MP. Alzheimer's disease: pathological mechanisms and recent insights. *Curr Neuropharmacol*. 2011;9(4):674–84.
- Northam EA, Anderson PJ, Jacobs R, Hughes M, Warne GL, Werther GA. Neuropsychological profiles of children with type 1 diabetes 6 years after disease onset. *Diabetes Care*. 2001;24(9):1541–6.
- Northam EA, Rankins D, Cameron FJ. Therapy insight: the impact of type 1 diabetes on brain development and function. *Nat Clin Pract Neurol*. 2006;2(2):78–86.
- Nouwen A, Winkley K, Twisk J, Lloyd CE, Peyrot M, Ismail K, et al. Type 2 diabetes mellitus as a risk factor for the onset of depression: a systematic review and meta-analysis. *Diabetologia*. 2010;53(12):2480–6.
- Nouwen A, Nefs G, Caramlau I, Connock M, Winkley K, Lloyd CE, et al. Prevalence of depression in individuals with impaired glucose metabolism or undiagnosed diabetes: a systematic review

- and meta-analysis of the European Depression in Diabetes (EDID) Research Consortium. *Diabetes Care*. 2011;34(3):752–62.
- Palta P, Schneider AL, Biessels GJ, Touradji P, Hill-Briggs F. Magnitude of cognitive dysfunction in adults with type 2 diabetes: a meta-analysis of six cognitive domains and the most frequently reported neuropsychological tests within domains. *J Int Neuropsychol Soc*. 2014;20(3):278–91.
- Park M, Katon WJ, Wolf FM. Depression and risk of mortality in individuals with diabetes: a meta-analysis and systematic review. *Gen Hosp Psychiatry*. 2013;35(3):217–25.
- Payne ME, Steck SE, George RR, Steffens DC. Fruit, vegetable, and antioxidant intakes are lower in older adults with depression. *J Acad Nutr Diet*. 2012;112(12):2022–7.
- Petrak F, Hardt J, Wittchen HU, Kulzer B, Hirsch A, Hentzelt F, et al. Prevalence of psychiatric disorders in an onset cohort of adults with type 1 diabetes. *Diabetes Metab Res Rev*. 2003;19(3):216–22.
- Petrak F, Baumeister H, Skinner TC, Brown A, Holt RI. Depression and diabetes: treatment and health-care delivery. *Lancet Diabetes Endocrinol*. 2015;3(6):472–85.
- Pibernik-Okanovic M, Roglic G, Prasek M, Metelko Z. Emotional adjustment and metabolic control in newly diagnosed diabetic persons. *Diabetes Res Clin Pract*. 1996;34(2):99–105.
- Polonsky WH, Anderson BJ, Lohrer PA, Welch G, Jacobson AM, Aponte JE, et al. Assessment of diabetes-related distress. *Diabetes Care*. 1995;18(6):754–60.
- Pouwer F, Tack CJ, Geelhoed-Duijvestijn PH, Bazelmans E, Beekman AT, Heine RJ, et al. Limited effect of screening for depression with written feedback in outpatients with diabetes mellitus: a randomised controlled trial. *Diabetologia*. 2011;54(4):741–8.
- Punthakee Z, Miller ME, Launer LJ, Williamson JD, Lazar RM, Cukierman-Yaffee T, et al. Poor cognitive function and risk of severe hypoglycemia in type 2 diabetes: post hoc epidemiologic analysis of the ACCORD trial. *Diabetes Care*. 2012;35(4):787–93.
- Reger MA, Watson GS, Green PS, Wilkinson CW, Baker LD, Cholerton B, et al. Intranasal insulin improves cognition and modulates beta-amyloid in early AD. *Neurology*. 2008;70(6):440–8.
- Risner ME, Saunders AM, Altman JF, Ormandy GC, Craft S, Foley IM, et al. Efficacy of rosiglitazone in a genetically defined population with mild-to-moderate Alzheimer's disease. *Pharmacogenomics J*. 2006;6(4):246–54.
- Rovet JF, Ehrlich RM. The effect of hypoglycemic seizures on cognitive function in children with diabetes: a 7-year prospective study. *J Pediatr*. 1999;134(4):503–6.
- Roy MS, Roy A, Affouf M. Depression is a risk factor for poor glycemic control and retinopathy in African-Americans with type 1 diabetes. *Psychosom Med*. 2007;69(6):537–42.
- Roy T, Lloyd CE, Pouwer F, Holt RI, Sartorius N. Screening tools used for measuring depression among people with type 1 and type 2 diabetes: a systematic review. *Diabet Med*. 2012;29(2):164–75.
- Ruis C, Biessels GJ, Gorter KJ, van den Donk M, Kappelle LJ, Rutten GE. Cognition in the early stage of type 2 diabetes. *Diabetes Care*. 2009;32(7):1261–5.
- Ryan C, Vega A, Drash A. Cognitive deficits in adolescents who developed diabetes early in life. *Pediatrics*. 1985;75(5):921–7.
- Ryan CM, Geckle MO, Orchard TJ. Cognitive efficiency declines over time in adults with type 1 diabetes: effects of micro- and macrovascular complications. *Diabetologia*. 2003;46(7):940–8.
- Scollan-Koliopoulos M, Herrera I, Romano K, Gregory C, Rapp K, Bleich D. Healthcare technician delivered screening of adults with diabetes to improve primary care provider recognition of depression. *J Family Med Prim Care*. 2012;1(2):97–102.
- Sellick SM, Crooks DL. Depression and cancer: an appraisal of the literature for prevalence, detection, and practice guideline development for psychological interventions. *Psychooncology*. 1999;8(4):315–33.
- Serretti A, Mandelli L. Antidepressants and body weight: a comprehensive review and meta-analysis. *J Clin Psychiatry*. 2010;71(10):1259–72.

- Simon GE, Katon WJ, VonKorff M, Unutzer J, Lin EH, Walker EA, et al. Cost-effectiveness of a collaborative care program for primary care patients with persistent depression. *Am J Psychiatry*. 2001;158(10):1638–44.
- Simon GE, Katon WJ, Lin EH, Rutter C, Manning WG, Von KM, et al. Cost-effectiveness of systematic depression treatment among people with diabetes mellitus. *Arch Gen Psychiatry*. 2007;64(1):65–72.
- Sinclair AJ, Armes DG, Randhawa G, Bayer AJ. Caring for older adults with diabetes mellitus: characteristics of carers and their prime roles and responsibilities. *Diabet Med*. 2010;27(9):1055–9.
- Sinclair A, Morley JE, Rodriguez-Manas L, Paolisso G, Bayer T, Zeyfang A, et al. Diabetes mellitus in older people: position statement on behalf of the International Association of Gerontology and Geriatrics (IAGG), the European Diabetes Working Party for Older People (EDWPOP), and the International Task Force of Experts in Diabetes. *J Am Med Dir Assoc*. 2012;13(6):497–502.
- Sinclair AJ, Gadsby R, Hillson R, Forbes A, Bayer AJ. Brief report: use of the mini-cog as a screening tool for cognitive impairment in diabetes in primary care. *Diabetes Res Clin Pract*. 2013;100(1):e23–5.
- Sjblom P, Tengblad A, Lofgren UB, Lantering C, Anderberg N, Rosenqvist U, et al. Can diabetes medication be reduced in elderly patients? An observational study of diabetes drug withdrawal in nursing home patients with tight glycaemic control. *Diabetes Res Clin Pract*. 2008;82(2):197–202.
- Skinner ML, Shirtcliff EA, Haggerty KP, Coe CL, Catalano RF. Allostatic model facilitates understanding race differences in the diurnal cortisol rhythm. *Dev Psychopathol*. 2011;23(4):1167–86.
- Sturt J, Dennick K, Due-Christensen M, McCarthy K. The detection and management of diabetes distress in people with type 1 diabetes. *Curr Diab Rep*. 2015;15(11):101.
- Thorpe CT, Gellad WF, Good CB, Zhang S, Zhao X, Mor M, et al. Tight glycemic control and use of hypoglycemic medications in older veterans with type 2 diabetes and comorbid dementia. *Diabetes Care*. 2015;38(4):588–95.
- Turner PR, O'Connor K, Tate WP, Abraham WC. Roles of amyloid precursor protein and its fragments in regulating neural activity, plasticity and memory. *Prog Neurobiol*. 2003;70(1):1–32.
- van den Berg E, Kloppenborg RP, Kessels RP, Kappelle LJ, Biessels GJ. Type 2 diabetes mellitus, hypertension, dyslipidemia and obesity: a systematic comparison of their impact on cognition. *Biochim Biophys Acta*. 2009;1792(5):470–81.
- van der Feltz-Cornelis CM. Comorbid diabetes and depression: do E-health treatments achieve better diabetes control? *Diabetes Manag*. 2013;3(5):379–88.
- van der Feltz-Cornelis CM, Nuyen J, Stoop C, Chan J, Jacobson AM, Katon W, et al. Effect of interventions for major depressive disorder and significant depressive symptoms in patients with diabetes mellitus: a systematic review and meta-analysis. *Gen Hosp Psychiatry*. 2010;32(4):380–95.
- van Duinkerken E, Schoonheim MM, Sanz-Arigita EJ, IJzerman RG, Moll AC, Snoek FJ, et al. Resting-state brain networks in type 1 diabetic patients with and without microangiopathy and their relation to cognitive functions and disease variables. *Diabetes*. 2012;61(7):1814–21.
- van Steenbergen-Weijenburg KM, de Vroege L, Ploeger RR, Brals JW, Vloedveld MG, Veneman TF, et al. Validation of the PHQ-9 as a screening instrument for depression in diabetes patients in specialized outpatient clinics. *BMC Health Serv Res*. 2010;10:235.
- van Steenbergen-Weijenburg KM, van Puffelen AL, Horn EK, Nuyen J, van Dam PS, van Benthem TB, et al. More co-morbid depression in patients with type 2 diabetes with multiple complications. An observational study at a specialized outpatient clinic. *Diabet Med*. 2011;28(1):86–9.
- Watson GS, Cholerton BA, Reger MA, Baker LD, Plymate SR, Asthana S, et al. Preserved cognition in patients with early Alzheimer disease and amnesic mild cognitive impairment during treatment with rosiglitazone: a preliminary study. *Am J Geriatr Psychiatry*. 2005;13(11):950–8.
- Weyerer S. Physical inactivity and depression in the community. Evidence from the Upper Bavarian Field Study. *Int J Sports Med*. 1992;13(6):492–6.

- Whitmer RA, Karter AJ, Yaffe K, Quesenberry CP Jr, Selby JV. Hypoglycemic episodes and risk of dementia in older patients with type 2 diabetes mellitus. *JAMA*. 2009;301(15):1565–72.
- Williamson JD, Launer LJ, Bryan RN, Coker LH, Lazar RM, Gerstein HC, et al. Cognitive function and brain structure in persons with type 2 diabetes mellitus after intensive lowering of blood pressure and lipid levels: a randomized clinical trial. *JAMA Intern Med*. 2014;174(3):324–33.
- Willis T. *Pharmaceutice rationalis sive diabtriba de medicamentorum operantionibus in humano corpore*. Oxford; 1675.
- World Health Organisation. Schedule for Clinical Assessment in Neuropsychiatry 2.1. 1999. <http://whoscan.org/wp-content/uploads/2014/10/xinterview.pdf>. Last accessed 17 Sept 2016.
- Zilkens RR, Davis WA, Spilsbury K, Semmens JB, Bruce DG. Earlier age of dementia onset and shorter survival times in dementia patients with diabetes. *Am J Epidemiol*. 2013;177(11):1246–54.

# Index

## A

- ABCD trial, 114
- Acanthosis nigricans, 439
- ACCORD trial, 114, 117
- Acetyl-CoA carboxylase 2, 85
- Acrochordons, *see* Skin tags
- Acromegaly, 581, 590
- Activated protein C, 187
- Acupuncture, 328
- Acute painful treatment-induced neuropathy, 289
- Adipokines, 9, 13, 17–19, 21, 42, 80, 86
- Adiponectin, 119
- Adipose tissue, 3, 11, 13, 15–23, 42, 546
- Advanced glycation end-products, 132, 134, 420, 438
- Albuminuria, 118
- Albuminuria-centric model, 210
- Aldose reductase, 166, 237
- Aldosterone blockade, 120, 121
- Aliskiren, 177, 223
- ALLHAT, 116, 551
- Alpha-lipoic acid, 308–309
- Alzheimer's disease, 280
- American College of Cardiology/American Heart Association (ACC/AHA) guidelines, 63
- American Diabetes Association (ADA), 117, 118, 141, 143
- American Foundation of Urological Disease (AFUD), 484
- AMP-activated protein kinase, 85
- Angiotensin-converting enzyme, 111, 112
- Angiotensin-converting enzyme 2, 112
- Angiotensin-converting enzyme inhibitor, 116, 118, 120
- Angiotensin II receptor blockers, 116, 119
- Angiotensinogen, 111, 112
- Ankle-brachial index, 139
- Anti-androgens, 402
- Anti-apoptotic program, 525
- Antiarrhythmic drugs, 557
- Antibiotics, 558
- Antidepressant drug, 562
- Antidiabetic drugs, cancer, 390–391
  - GLP-1R agonists and GLP-1 degradation inhibitors, 399
  - insulin analogs, 391, 394–396
  - in vitro* experimental evidences, 391–394
  - oral, 396–399
  - SGLT2 inhibitors, 400
- Antiepileptics, 416, 560
- Antihypertensive(s), 423
  - treatment
    - beta-blocking agents, 552–553
    - CCBs, 553
    - thiazide diuretics, 550–552
- Anti-infectives
  - antibiotics, 558
  - antimycobacterials, 558
  - antiprotozoals, 560
  - antivirals, 559
- Antimycobacterials, 558
- Antineoplastic agents, 562
- Anti-osteoporotic treatment, 428
- Antiprotozoals, 560
- Antipsychotic drugs, 560
- Antivirals, 559
- Apocynin, 170
- Apolipoprotein A-I, 54, 60, 61
- Apolipoprotein B, 55–60
- Arteriosclerosis, 224
- ARIDCT, 168
- Aspart, 669
- Atherogenic dyslipidemia, 93
- Atherosclerosis, 224



- Atherosclerotic cardiovascular disease, 53, 58, 62, 66
- Atrial natriuretic peptide, 122
- Autonomic dysfunction, 358
- B**
- Baicalein, 170
- Bariatric surgery, 23, 25, 26, 39, 518
- Bayesian network, 518
- Beger's procedure, 529
- Beta-blocking agents, 552
- Beta cell function, 11, 12, 16
- Bilateral optic atrophy, 235
- Blood pressure, 110, 111, 113–115, 117, 118, 122, 123
- Body mass index (BMI), 3, 7, 11, 12, 18, 19, 34, 37, 41
- Bone disease, *see* Diabetic bone disease
- Bone marrow adipose tissue, 414
- Bone mineral density, 413, 424
- Bone remodeling, 416–418
- Bone turnover, 425
- Botulinum toxin, 327
- Brain metabolism, 620
- Breast cancer mortality, 384
- Breastfeeding, 673
- Bullous disease of diabetes (bullosis diabetorum), 442
- Bupropion, 38
- C**
- Calcium channel blockers, 115, 116, 118, 120, 553
- Calcium channel modulators, 324–325
- Cancer and diabetes, 390
- antidiabetic drugs and cancer risk (*see* Antidiabetic drugs, cancer)
  - bladder cancer, 382
  - breast cancer mortality, 384–385
  - colorectal adenomas and carcinomas, 382
  - colorectal cancer mortality, 385
  - endometrial cancer mortality, 385
  - female reproductive organs, 382
  - general mechanisms, 387–389
  - hyperglycemia and insulin-resistance, cancer-drugs (*see* Cancer-drugs and hyperglycemia)
  - kidney cancer, 382
  - liver cancer, 380
  - lung cancer, 382
  - non-Hodgkin's lymphoma, 382
  - pancreatic cancer, 380–381
  - prostate cancer, 382, 385
  - site-specific mechanisms, 389–390
  - type 1 diabetes, 383–384
- Cancer-drugs and hyperglycemia, 400–401
- anti-androgens, 402
  - glucocorticoids, 401–402
  - insulin signaling pathways, 402–403
  - lifestyle intervention, 403
  - somatostatin long-acting analogs, 402
- Cardiac autonomic neuropathy, 305–306
- Cardiovascular disease, 62
- Cardiovascular system and diabetes
- CAD, screening for, 136–137
  - cerebrovascular disease, 138–139
  - diabetic cardiomyopathy and heart failure, 138
  - diabetic macroangiopathy (*see* Macroangiopathy)
  - impaired vascular repair, 135
  - PAD, 139
  - vascular damage, mechanisms of, 132–135
- Central nervous system
- Alzheimer's disease, 280
  - epidemiology, 279
  - fMRI measurements, 278–279
  - hypothalamic pituitary–adrenal, 282
  - neuropsychological testing, 282
  - structural changes, 277
- Cerebrovascular disease, 138
- Charcot neuroarthropathy, 369, 370
- Chlorthalidone, 118
- Chronic inflammation, 466
- Chronic kidney disease (CKD), 113, 122, 124, 212, 503
- Chronic pancreatitis, 525
- Chylomicrons, 53, 58, 60, 62
- Cognitive dysfunction and diabetes
- in adults, 702–703
  - in children and adolescents, 700
- Cognitive function, 700
- Collagen, 416
- Colorectal adenomas and carcinomas, 382
- Colorectal cancer mortality, 385
- Color fundus photography, 238–241
- Common soil hypothesis, 458
- Common Terminology Criteria for Adverse Events, 401
- Complications, 496–500
- cardiovascular, cardiac and arrhythmic, 505
  - cardiovascular, cardiac and kidney, 508
  - liver-related, 509
  - microvascular diabetic, 503–505

- Congenital anomalies, 660  
 Continuous glucose monitoring system, 619  
 Contraception, 673  
 Coronary artery disease, 136, 481  
 Coronary heart disease, 132  
 Cortical porosity, 424–425  
 Counterregulation, 617, 618, 619, 621, 623–625, 627, 630, 636  
 Counterregulatory hormones, 577–581  
 Cushing's disease, 590  
 Cushing's syndrome, 580  
 Cystic fibrosis-related diabetes, 529
- D**
- DCCT, 35  
 Dementia and diabetes  
   definition, 703  
   diagnosis, 705  
   glycemic targets, 707  
   prevention of, 705  
   risk factor, 704  
   treatment, 706  
 Demyelinating neuropathy, 288  
 Dental implant therapy, 461–467  
 Depression and diabetes  
   antecedents, 695  
   biological changes, 694  
   consequences, 696  
   and distress, 691–692  
   epidemiology, 689–691  
   model of care, 699–700  
   pharmacotherapy, 698–699  
   psychological response, 693  
   psychological treatment, 698  
   risk factor, 693  
   screening and diagnosis, 696–698  
   self-care management, 694  
   specific populations, 692  
 Detemir, 670  
 Diabetes  
   comorbidities, 415, 423  
   complications, 474, 480, 481, 488  
   definition and classification of, 4–6  
 Diabetes mellitus, 259–262  
   apo A-containing lipoproteins, 60–61  
   dietary lipids, 55–56  
   endogenous lipids, 56–60  
 Diabetic bone disease  
   antidiabetic drugs, 421–423  
   bone turnover markers, 425  
   comorbidities, 423–424  
   diagnostic approach, 426  
   microindentation, 425  
   pathophysiology, 417–421  
   scanning modalities, 424–425  
   treatment, 428  
 Diabetic dermopathy, 447  
 Diabetic foot, 443  
 Diabetic foot infections, 365  
 Diabetic foot ulcers  
   Charcot neuroarthropathy, 369, 370  
   debridement, 364  
   growth factors and skin substitutes, 368  
   hyperbaric oxygen therapy, 368  
   multidisciplinary diabetes team, 372  
   negative pressure wound therapy, 368  
   neuro-ischemic ulcers, 365  
   neuropathic ulcers, 364  
   offloading, 364–365  
   patient education, 371  
   wound dressings, 366, 367  
 Diabetic ketoacidosis  
   bicarbonate administration, 609  
   fluid therapy, 606  
   hyperglycemic crises, 606  
   insulin therapy, 608  
   laboratory findings, 604–605  
   laboratory pitfalls, 605–606  
   pathogenesis, 597–599  
   phosphate deficiency, 609  
   potassium deficit, 608–609  
   precipitating causes, 599–602  
   prevention, 610  
   subcutaneous insulin, transition, 609  
   symptoms and signs, 602–603  
 Diabetic kidney disease  
   and cardiovascular disease, 223–226  
   clinical presentation, 205–213  
   glomerular hemodynamic and blood pressure control, 218–223  
   glucose control, 213–217  
   insulin treatment, 217–218  
   prevalence, 204–205  
 Diabetic lumbar polyradiculopathy, 288  
 Diabetic macular edema, 236  
 Diabetic neuropathy  
   classification, 285  
   glycemic and metabolic control, 307–308  
   growth factors, 309  
   quality of Life, 304  
   intraepidermal nerve fiber density, 301  
   *in vivo* corneal confocal microscopy, 301  
   nerve conduction studies, 304  
   oxidative stress, 308  
   pathogenic mechanisms, 284–285, 307–309

- Diabetic neuropathy (*cont.*)  
 quantitative sensory testing, 300–301  
 sudomotor function, 303
- Diabetic peripheral neuropathy  
 autonomic dysfunction, 358  
 clinical examination, 361  
 clinical history, 361  
 diabetic foot ulcers, 359  
 foot ulceration, 358–359  
 high-risk foot, 361  
 high risk patient, 363  
 lower limb complications, 360  
 neurological assessment, 362  
 peripheral ischemia, 359  
 sensorimotor peripheral neuropathy, 358  
 vascular assessment, 362  
 wound classification, 363
- Diabetic thoracic polyradiculopathy, 289
- Diacylglycerol, 172
- Diaphanous-1, 168
- Diet, 9, 24, 33–35, 37
- Diet therapies  
 dyslipidemia, 61  
 lipids, 54–56  
 VLDL, 56
- Dipeptidyl peptidase-4 inhibitors, 36, 146
- Distal symmetric polyneuropathy  
 classification, 295  
 clinical assessment, 296–299  
 diagnosis, 300  
 falls risk, 290–294  
 physical examination, 290
- Dyslipidemia and diabetes  
 apo A-containing lipoproteins, 60–61  
 apo B-100-containing lipoproteins, 56–59  
 apo B-48-containing lipoproteins, 55–56  
 bile acid binding resins, 65–66  
 ezetimibe, 64  
 fibrates, 65  
 niacin, 65  
 nonpharmacologic therapies, 61–62  
 PCSK9 inhibitors, 64–65  
 statin therapy, 63–64
- E**
- Ectopic fat, 76, 88
- Edmonton Obesity Staging System, 25, 30
- Electrical spinal cord stimulation, 328
- Enalapril, 222
- Endocrine disorders  
 hyperaldosteronism, 583, 584  
 male hypogonadism, 584–585  
 polycystic ovary syndrome, 585–590  
 somatostatinoma, 582  
 thyroid dysfunction, 582–583
- Endometrial cancer mortality, 385
- Endothelial nitric oxide synthase, 170, 174, 183, 188
- Endothelial progenitor cells, 135, 146, 188, 189
- Enhanced liver fibrosis score, 498, 511
- Erectile dysfunction  
 definition, 474  
 diagnosis, 480–481  
 epidemiology and risk factors, 475  
 hyperglycemia, 476–477  
 hypogonadism, 480  
 lifestyle changes, 482–483  
 neuropathy, 478  
 pharmacologic therapy, 483–484  
 physiology of penile erection, 475–476  
 prevalence of, 474  
 psychological issues, 480  
 vasculopathy, 477–478  
 visceral adiposity, 478–480
- Eruptive xanthomas, 444
- Estimated glomerular filtration rates, 118, 122
- European Prospective Investigation into Cancer study, 13
- EXAMINE trial, 400
- Expert Panel Report, 113
- Ezetimibe, 64
- F**
- Farnesoid X receptor, 517
- Fasting plasma glucose, 4
- Fat distribution, 3, 14, 17, 19, 42
- Fatty liver, *see* Non-alcoholic fatty liver disease
- Female sexual dysfunction  
 definition of, 484  
 diagnosis, 488–489  
 endocrinological disorders, 487–488  
 epidemiology and risk factors, 485–486  
 hormonal therapy, 490  
 hyperglycemia, 487  
 lifestyle change, 489–490  
 mechanical devices, 490–491  
 physiology of female sexual response, 486–487  
 prevalence of, 484  
 psychological factors, 488  
 psychological issue treatment, 491  
 vascular and nerve dysfunctions, 487
- Female Sexual Function Index (FSFI), 488
- Fibrates, 65

Fibro-glial tissue, 236  
FibroScan<sup>®</sup>, 498  
Fluid therapy, 606  
Focal neuropathy, 286  
Fracture Risk Assessment Tool (FRAX), 416  
Free-fatty acids, 145  
Frequency-modulated electromagnetic nerve stimulation, 328  
FSFI, *see* Female Sexual Function Index (FSFI)

**G**

Generalized granuloma annulare, 441  
Genetics, 3, 8, 11, 16  
Genome-wide association studies (GWAS), 12, 112  
Gestational diabetes mellitus, 4  
    Cesarean delivery, 671  
    classification and diagnosis, 655–659  
    congenital anomalies, 660  
    continuous glucose monitoring system, 670–671  
    diet and nutrition adjustments, 664  
    epidemiology, 654  
    fetal assessment, 663  
    glucose control, during labor and delivery, 672  
    glucose monitoring, 662  
    glycemic goals, 663  
    insulin, 668  
    long term fetal complications, 662  
    macrosomia, 661  
    management of, 662  
    neonatal complications, 661  
    oral antidiabetic agents, 665–666  
    pathophysiology, 654  
    physical activity, 665  
    post-partum management, 673–675  
    preconception care, 662  
    spontaneous abortion, 661  
    stillbirth, 661  
    subcutaneous continuous insulin infusion, 670  
    timing and mode of delivery, 671  
    weight gain, 663  
Glargine, 670  
Global Burden of Disease Study, 6  
Glomerular filtration rate (GFR), 205–220, 223, 225  
Glucagon-like peptide 1, 123  
    degradation inhibitors, 399  
Glucagon-like peptide-1 receptor agonists, 146, 147, 399

Glucagonoma, 578  
Glucocorticoids  
    insulin resistance, 545  
    insulin secretion, 547  
Glucose counterregulation, 577  
Glucose lowering drugs, 421, 422  
Glucosensors, 620  
Glyburide, 666  
Glycemic control, 250, 307–308, 500  
Glycosuria, 212, 216, 219  
Granulocyte colony stimulating factor, 368  
Growth hormone, 548

**H**

Hard exudates, 236  
Hemoglobin A1c, 456, 458–460, 464, 465  
Hepatic steatosis, 497, 499, 507, 512, 514, 516, 517  
Hepatocellular carcinoma, 380, 502, 503, 515  
Hereditary hemochromatosis, 530  
High density lipoprotein, 53, 56, 60–61, 65, 142  
High resolution peripheral quantitative computed tomography, 424, 425  
Hip fracture, 413, 420, 426  
HOT trial, 113  
Hyperaldosteronism, 583  
Hyperbaric oxygen therapy, 368  
Hypercholesterolemia, 65, 66  
Hyperfiltration, 122  
Hyperglycemia, 164, 219, 418, 420  
    antiarrhythmic drugs, 557–558  
    antihypertensive treatment, 550–554  
    anti-infectives, 558–560  
    antineoplastic agents, 562  
    and cancer, 400  
    glucocorticoids and hormones, 547–548  
    growth hormone, 548–549  
    immunosuppressive agents, 563–564  
    lipid-modifying agents, 554–557  
    nervous system, drug affecting of, 560–562  
    oral combined contraceptives, 548  
    somatostatin analogs, 549–550  
Hyperglycemia and Adverse Pregnancy Outcomes study, 658  
Hyperinsulinemia, 111, 113, 501  
Hyperparathyroidism, 584  
Hypertension and diabetes

- Hypertension and diabetes (*cont.*)  
 antihypertensive agents, effect of, 115–116  
 approach to treatment, 116–123  
 blood pressure treatment, goals of, 113  
 implications of, 110  
 insulin resistance, 111  
 obesity, 110, 111
- Hypertriglycerides  
 LDL, 59  
 niacin, 65  
 VLDL, 62
- Hypertriglyceridemia, 55, 56, 59, 62, 65, 66
- Hypoactive sexual desire disorder, 490
- Hypocaloric diet, 33
- Hypoglycemia  
 brain metabolism and glucosensors, 620  
 cardiovascular risk, 629–633  
 consequences, 629  
 definition, 629  
 economic burden, 633  
 in elderly people, 626  
 HAAF, 627  
 impaired awareness, 627  
 liver and kidneys, endogenous glucose production, 622  
 neuroendocrine responses, 622  
 prevention, 635–639  
 treatment, 639–641  
 type 1 diabetes, 617, 635  
 type 2 diabetes, 618, 638
- Hypoglycemic agent and cancer, 378, 395
- Hypogonadism, 476, 480, 483
- Hyponatremia, 293
- Hypothalamic pituitary–adrenal, 282
- I**
- IIEF-5, 481
- Incretins, 215, 419–420  
 mimetic drugs, 515
- Indapamide, 118
- Insulin, 668–670  
 and cancer  
 insulin analogs, 391, 394  
 insulin signaling pathways, 402  
 receptor and cancer, 388, 391  
 resistance, 3, 4, 9, 11–14, 16–18, 35, 75, 76, 82, 85, 87, 91, 92, 545  
 secretion, 547
- Insulin receptor substrate, 16, 17
- Intensive insulin therapy, 617, 625, 629, 640
- International Association of Diabetes in Pregnancy Study Groups, 658
- International Index of Erectile Function, 481
- Intraepidermal nerve fiber density, 301
- In vivo corneal confocal microscopy, 301
- Islet dysfunction, 527
- Isulin therapy, 608
- J**
- Joslin Medalist Program, 165
- K**
- Kallikrein-kinin system, 178, 181
- Ketoacidosis, *see* Diabetic ketoacidosis
- Kidney cancer, 382
- Kidney disease, *see* Diabetic kidney disease
- Kidney Disease Improving Global Outcomes guidelines, 115
- L**
- LEADER trial, 147
- Lipid-modifying agents  
 nicotinic acid, 557  
 statins, 554–557
- Lipid therapies  
 LDL cholesterol level, 63  
 lipoproteins, 53
- Lipopolysaccharides, 454
- Lipoprotein lipase, 76
- Lipoproteins  
 apo A, 60  
 apo B-100, 56  
 apo B-48, 54
- Liraglutide, 38, 516
- Lispro, 669
- Liver cancer, 380
- Long-chain acyl CoA, 15
- Lorcaserin, 38
- Low density lipoprotein, 53, 55, 58–60, 62, 66, 76, 142
- Lung cancer, 382
- M**
- Macroangiopathy  
 glucose lowering medications and prevention of, 143–149  
 glycemic targets, prevention, 142–143  
 therapeutic multifactorial approach to, 140–142

- Macrosomia, 661  
 Macular edema, *see* Diabetic macular edema  
 Metabolic control, 307–308  
 Metabolic syndrome
  - atherogenic dyslipidemia, 93–94
  - genetics, 78
  - hyperglycemia, 94
  - hypertension, 94
  - insulin resistance, 75
  - lifestyle intervention on, 92–93
  - obesity, 75–76, 91–92
  - overnutrition on specific tissues  
(*see* Overnutrition)
  - pro-inflammatory state, 94–95
  - pro-thrombotic state, 94
  - timeline for development, 90–91
 Metanx, 326  
 Metformin, 214, 515, 532, 667  
 Microalbuminuria, 136, 209–211  
 Microaneurysms, 236  
 Microhemorrhages, 236  
 Microindentation, 425  
 Microvascular complications
  - activated protein C, 187
  - antioxidant enzymes, 183, 184
  - classification, 162
  - endoplasmic reticulum, 178
  - genetic and epigenetic regulation, 164
  - glycation modification of proteins, 169
  - insulin, 183
  - kallikrein-bradykinin system, 178, 179
  - molecular mechanisms of injury, 166
  - oxidative stress, 169, 171
  - polyol pathway, 168
  - renin-angiotensin system, 177
  - SHP-1 activation, 186
  - tissue response, 164, 166
  - transforming growth factor, 186
  - vascular endothelial growth factors,  
186, 187
  - vascular progenitor cells, 188
 Mitochondria, 170  
 Mitogen-activated protein kinase pathway, 148  
 Multidisciplinary diabetes team, 371–372  
 Multifocal electroretinography, 249  
 Multifocal neuropathies, 286
- N**
- NAFLD, *see* Non-alcoholic fatty liver disease  
 NASH, *see* Non-alcoholic steatohepatitis  
 National Health and Human Nutrition  
 Examination Surveys (NHANES), 30  
 National Health and Nutrition Examination  
 Survey-I, 138  
 NCD Risk Factor Collaboration, 7  
 Necrobiosis lipoidica, 439  
 Necrobiosis lipoidica diabetorum, 439  
 Negative pressure wound therapy, 368  
 Neovascular glaucoma, 234, 236  
 Nephropathy, 110, 114, 117, 119, 120, 122  
 Nerve conduction studies, 304  
 Nerve growth factor, 309  
 Neuro-ischemic ulcers, 365  
 Neuropathic pain
  - acupuncture, 328
  - antidepressants, 322–323
  - calcium channel modulators, 324–325
  - comorbidities, 313–314
  - diagnosis, 315
  - epidemiology, 314
  - management, 315
  - nociceptive and non-nociceptive, 312
  - pathogenetic mechanism, 311
  - pharmacological treatment, 315–317
  - physical measurement, 328
  - psychological support, 327
  - reuptake inhibitors, 323
  - sodium channel blockers, 326
  - surgical decompression, 329
  - topical agents, 317
 Neuropathy, *see* Diabetic neuropathy  
 Neuropathy Total Symptoms Score–6  
 (NTSS-6) total score, 176  
 Neutral protamine Hagedorn insulin, 670  
 Niacin, 65  
 Nicotinic acid, 557  
 Nitric oxide (NO), 475  
 Non-albuminuric renal impairment, 210  
 Non-alcoholic fatty liver disease, 87, 496
  - cardiovascular, cardiac and arrhythmic  
 complications, risk of, 505–508
  - cardiovascular, cardiac and kidney  
 complications, 508–509
  - CKD and microvascular diabetic  
 complications, risk of, 503
  - diagnosis of, 497–498
  - epidemiology and natural history of,  
 499–500
  - liver-related mortality and morbidity, risk  
 of, 501–503
  - management of, 509–512
  - and poor glycemic control, 500–501
  - treatment options for, 512–518
 Non-alcoholic steatohepatitis, 496–502, 507,  
 508, 511, 512, 514–518

Non-esterified (free) fatty acids, 14, 15  
 Non-Hodgkin's lymphoma, 382  
 Nuclear factor- $\kappa$ B, 133

## O

Obesity, 2  
 behavior modifications, 30–33  
 definition, 3  
 and diabetes  
 antidiabetic medications and body weight, 35–36  
 epidemiology of, 6–8  
 genetics of, 11–13  
 pathophysiology of, 8–11  
 T2D, risk factor for (*see* Type 2 diabetes and obesity)  
 diets for weight loss, 33  
 fundamental cause of, 3  
 increased physical activity, 35  
 management of, 25–30  
 Olmesartan, 222  
 Omega-3 fatty acids, 62  
 ONTARGET, 114  
 Opioids, 321–322  
 Optical coherence tomography, 242–248  
 Oral antidiabetic agents, 665  
 Oral combined contraceptives, 548  
 Oral glucose tolerance test, 4  
 Orbital mucormycosis, 232  
 Oscillatory potentials, 248  
 Osseointegration, 462, 464  
 Osteoporosis, 417  
 Overnutrition  
 adipose tissue, 78–80  
 carbohydrate, 88–90  
 and energy imbalance, 76–78  
 heart, 88  
 kidney, 88  
 liver, 86–88  
 pancreatic beta cells, 81  
 skeletal muscle, 81–86  
 Oxidative glucose metabolism, 15  
 Oxidative stress, 169, 308

## P

Painful diabetic peripheral neuropathy  
 gabapentin, 324  
 tricyclic antidepressants, 322  
 Pancreas duodenum homeobox-1, 15  
 Pancreatic cancer, 526–527  
 Panretinal photocoagulation, 254

Pasireotide, 549  
 PCSK9 inhibitors, 64  
 Pentoxifylline, 517  
 Peri-implantitis, 465, 467  
 Periodontal disease and diabetes  
 case-control study, 455  
 cross-sectional study, 456  
 dental implant therapy, 461  
 glycemic status, type 2 diabetes, 457–461  
 oral health, 457  
 pathogenesis of, 453–455  
 Peripheral artery disease, 132, 139–140  
 Peripheral neuropathy, *see* Diabetic peripheral neuropathy  
 Peripheral vascular disease, 359  
 Pharmacotherapy, 3, 13, 25, 33, 36–39, 42  
 Phentermine, 38  
 Pheochromocytoma, 579–580  
 Pigmented purpura, 447  
 Pin-prick test, 362  
 Platelet-derived growth factor, 368  
 Podocytes, 182  
 injury, 170  
 Poly(ADP-ribose) polymerase, 169  
 Polycystic ovary syndrome, 585  
 Polyol pathway, 166  
 Polyunsaturated fatty acids, 517  
 Potassium deficit, 608  
 PROactive study, 145  
 Proliferative retinopathy, 236  
 Proopiomelanocortin, 12  
 Prostaglandin E1, 476  
 Prostate cancer, 382, 385  
 Protein kinase C activation  
 in diabetic nephropathy, 173  
 in diabetic peripheral neuropathy, 176  
 in diabetic retinopathy, 174, 175  
 in fibroblasts and wound healing, 176, 177  
 in vascular tissue, 171, 172  
 Protein-tyrosine phosphatases, 17  
 Proteinuria, 205–213, 219–222  
 Pruritus, 446  
 Psoriasis, 444  
 Pupillary abnormalities, 234

## Q

Quantitative sensory testing, 300

## R

Radiculopathies/polyradiculopathies, 288  
 Ramipril, 221, 222

- Reactive oxygen species, 15, 134, 138  
 Receptors for AGEs, 168, 438  
 Renalase, 112  
 Renal disease, 204, 210, 212, 214  
 Renin-angiotensin aldosterone system, 111, 115, 117, 120  
 Renin-angiotensin system, 177, 210  
 Renin-angiotensin system blockers, 116, 119, 120  
 Retinopathy, 212
  - electrophysiological testing, 248, 249
  - epidemiology, 235
  - fluorescein angiography, 241–242
  - fundus photography, 238
  - kallikrein-kinin system, 179
  - medical treatment, 249–253
  - multifocal electroretinography, 249
  - natural history and classification, 236–237
  - oscillatory potentials, 248–249
  - pathogenesis, 237–238
  - protein kinase C activation, 174
  - wide field fundus photography, 241
 Rubeosis faciei, 446  
 Ruboxistaurin, 173, 175
- S**
- SAVOR-TIMI, 400  
 Scleredema diabeticorum, 443  
 Secondary diabetes, 578, 580, 581, 590  
 Selective serotonin reuptake inhibitors, 323  
 Sensorimotor peripheral neuropathy, 358  
 Serotonin noradrenaline reuptake inhibitors, 323–324  
 Sexual disorders and diabetes
  - erectile dysfunction, 474–484
  - female sexual dysfunction, 484–491
 SGLT inhibitors, 216  
 SGLT2 inhibitors, 121, 124  
 Silymarin, 170  
 Single-nucleotide polymorphisms, 112  
 Skeletal muscle, 546  
 Skin and diabetes
  - acanthosis nigricans, 439
  - acrochordons/skin tags, 445–446
  - bullous disease of diabetes, 442
  - diabetic dermopathy and pigmented purpura, 447
  - diabetic foot, 443–444
  - eruptive xanthomas, 444
  - generalized granuloma annulare, 441–442
  - generalized pruritus, 446
  - necrobiosis lipoidica diabeticorum, 439–441
  - psoriasis, 444–445
  - rubeosis faciei, 446
  - scleredema diabeticorum, 442–443
  - skin infections, 447, 448
  - yellow skin and nails, 446
 Skin tags, 445  
 Sodium channel blockers, 326  
 Sodium-glucose co-transporter-2 inhibitors, 148, 400, 516  
 Somatostatin analogs, 549  
 Somatostatin long-acting analogs, 402  
 Somatostatinoma, 582  
 Spontaneous abortion, 661  
 SPRINT trial, 114  
 Statins, 63, 422, 554  
 Sterol regulatory element binding protein 1c, 77  
 Stillbirth, 661  
 Stroke, 132  
 Subcutaneous continuous insulin infusion, 670  
 Sudomotor test, 303  
 Sulphonylurea(s), 515  
 Sulphonylurea receptor-1, 13  
 Swedish Obese Subjects study, 39  
 Systolic Hypertension in the Elderly Program (SHEP), 116
- T**
- Testosterone replacement therapy, 483  
 The Ipswich Touch Test, 362  
 Thiazide diuretics, 550  
 Thiazolidinediones, 215  
 Thiazolidinediones, 145  
 Thrombomodulin, 187  
 Thyroid dysfunction, 582  
 Topical capsaicin, 317  
 Topiramate, 38  
 Trabecular bone score, 424  
 Trandolapril, 222  
 Transcutaneous electrical nerve stimulation, 328  
 Tricyclic antidepressants, 322–323  
 128Hz Tuning fork test, 362  
 Type 1 diabetes (T1DM), 413, 424, 426
  - hypoglycemia, 617, 635
  - NAFLD (*see* Non-alcoholic fatty liver disease)
 Type 2 diabetes (T2DM), 72, 81, 82, 85, 413, 414, 425, 426
  - and cardiovascular disease, 674



- Type 2 diabetes (T2DM) (*cont.*)  
hypoglycemia, 618, 638  
and insulin resistance, 82  
intramyocellular lipid content in, 83  
and NAFLD (*see* Non-alcoholic fatty liver disease (NAFLD))  
and obesity  
adipose tissue dysfunction, role of, 18  
bariatric and metabolic surgery, 39–42  
and body fat distribution, 17  
glucose toxicity, role of, 15  
insulin resistance, role of, 16  
lipotoxicity, role of, 15–16  
mechanisms, 14  
pharmacotherapy of, 36  
prevention of, 24–25  
treatment of, 30
- Type 3c diabetes mellitus, 524  
causes, 524–531  
clinical diagnosis, 531–532  
management, 532–533  
prevalence, 524
- U**  
Ultra-wide field fluorescein angiography, 241  
Unawareness, hypoglycemia, 616, 617, 621, 627, 628, 635, 639  
Uncoupling protein-2, 15  
Unfolded protein response, 178  
United Kingdom Prospective Diabetes Study, 35, 113
- V**  
Vascular damage, 132  
advanced glycation end products, 132  
circulating progenitor cells, 135  
diacylglycerol, 132  
hexosamine pathway, 132  
polyol pathway, 132  
protein kinase C, 132  
reactive oxygen species, 132  
Vascular endothelial growth factor, 133, 256, 258, 309  
Vertebral fracture, 413, 426  
Very low calorie diet, 34, 35  
Very low density lipoproteins, 54–60, 62, 65, 66, 76, 87  
Vibration detection threshold, 176  
Vibration perception testing, 362  
Vitamin D<sub>3</sub>, 517  
Vulvovaginal atrophy, 490
- W**  
Weight loss, 3, 12, 24, 25, 30, 32, 33, 35–39, 42  
Whipple's operation, 528  
Wound healing, 176
- X**  
XENDOS study, 37
- Y**  
Yellow skin and nails, 446