

2 A Co-evolutionary Perspective on Distributed Manufacturing

Rob Dekkers

Division Management & Business Economics, UWS Business School, University of the West of Scotland, Paisley Campus, Paisley PA1 2BE (United Kingdom)
e-mail: rob.dekkers@uws.ac.uk

Abstract Research into Distributed Manufacturing has embraced the challenges facing industrial networks. Existing strands of research into networks often explore social-dynamic relationships and contractual aspects, thereby ignoring the underlying dynamics based on the characteristics: collaboration, decentralisation of decision-making and interorganisational integration, all pointing to mutual relationships in which co-evolution has gained a prominent place for modelling. Essential to the modelling of co-evolution is the combined development of agents involved, expressed by the factor for connected traits in the NK/C model. However, in this model co-evolution happens in semi-static landscapes, which hardly exist in the reality of industry. Hence, more advanced game-theoretic applications might serve as a foundation for understanding the development of networks since these describe the interactions between agents. This chapter expands on co-evolutionary models and includes the autonomous development of agents in a network, the connectivity between agents and the dynamic forms of collaboration and communication to advance research in Distributed Manufacturing.

2.1	Introduction	30
2.1.1	Emergence of Industrial Networks	31
2.1.2	Challenges for Contemporary Industrial Networks	32
2.1.3	Scope of Chapter	32
2.2	Evolutionary Perspectives	34
2.2.1	Co-evolution and Industrial Networks	35
2.2.2	Fitness Landscapes	35
2.2.3	Co-evolution and NK model	38
2.2.4	Percolation in Networks	38
2.2.5	Symbiosis	39
2.3	Distributed Manufacturing and Co-evolution	40
2.3.1	New Rationales for Distributed Manufacturing	40
2.3.2	Models for Co-evolution in Collaborative Networks	42
2.3.3	Game Theories and Collaborative Networks	43
2.3.4	Avenues for Research	44

2.4 Conclusion	45
References	46

2.1 Introduction

When Hermann Kühnle posed a request for a different perspective on collaboration in networks, the first thing that came to mind was how does the notion of Distributed Manufacturing differ from the concept of industrial networks? For industrial networks, we might assume that collaboration has become an eminent issue which has already caught the attention of academics for a considerable time. But what about Distributed Manufacturing with its origins in information technology? For this reason, this chapter deliberates on collaboration in Distributed Manufacturing.

Most efforts in Distributed Manufacturing have been directed towards applications of information technology from the mid-1990s onwards, like the design of its architecture (e.g. Maturana and Norrie 1996; Ryu and Jung 2003), resource and task allocation (e.g. Maropoulos et al. 2002; Tharumarajah 2001), and scheduling and control (e.g. Azevedo and Sousa 2000; Candadai et al, 1996; Duffie and Prabhu 1996; Fujii et al. 1999; Kingsman 2000; Maturana and Norrie 1995; Shen 2002). All these contributions have in common that they take autonomous agents in a network as their starting point (Sousa et al. 1999). This originated in the 1980s when the introduction of flexible manufacturing systems (FMS) called for a new control paradigm; that meant moving away from the centralised resource allocation embedded in material requirements planning (MRP) applications towards decentralised decision making, and it called on computer applications to supersede the control of independent units. Consequently, the emphasis has been on manufacturing architecture and control within single plants. Later, the term Distributed Manufacturing came to include the virtual manufacturing of products crossing the borders of a monolithic company Holonic Manufacturing Systems (Van Brussel et al. 1998, p. 255), bionic manufacturing systems (BMS), Fractal Factory and multi-agent systems (Leitão and Restivo 2000, pp. 2–4) and started to include the networked organisation (e.g. Tian et al. 2002, pp. 326–327). However, the impact of this expansion has been little discussed because of the traditional focus on information technology.

With its contemporary meaning, the research into Distributed Manufacturing has disconnected from the traditional drive towards developing simulations and software applications to the issues that surround industrial networks (Kühnle et al. 2005). As a result, only a few have written about collaboration in Distributed Manufacturing (e.g. Fagerström and Jackson 2002). Collaboration is also a hot topic in industrial networks and needs expansion beyond the current concepts to arrive at a more grounded theory (Bennett and Dekkers 2005; Dekkers et al. 2004;

Dekkers and van Luttervelt 2006). This call embraces the remark of Nassimbeni (1998, p. 539) that the bulk of available works is devoted to the contractual aspects and the social dynamics of interorganisational relationships in collaboration. Most likely, that attention to contractual and social aspects originates in the direct conversion from concepts for the hierarchical firm, with the direct control of resources and its strategy towards suppliers, to concepts for networks with more loosely connected entities; Camarinha-Matos and Afsarmaneshi (2005, p. 443) provide a similar argument. Research into industrial networks has mostly neglected the dynamic forms of communication and coordination, although networks do not present a new phenomenon. To that purpose, this chapter deliberates on collaboration in Distributed Manufacturing and connects this theme to co-evolutionary models to address dynamic forms of communication and coordination.

2.1.1 Emergence of Industrial Networks

Historically, networks have existed for a long time. It will suffice to point to the Silk Route as an ancient example of the global supply chain or to the existence of trading between Asia and Europe by the Dutch *Vereenigde Oostindische Compagnie* during the Golden Age of the Republic of the Netherlands (16th and 17th centuries). Even then, the contextual environments, i.e. the social environment in which the networks existed, determined to extend the transactional environment of trading relationships. Social-economic historians have investigated this domain to understand the networks that were present during the Commercial Revolution in the Middle Ages, an era seeing the resurgence of Mediterranean and European long-distance trading (e.g. Greif 1996). Later, the global supply chains, focusing on basic needs, agricultural goods and raw materials, were affected by the Industrial Revolution (Brasseul 1998, p. 8). Firstly, growing demand during that period increased the volume of trade. Secondly, the capability of sources (regions and nations) to produce their own intermediaries or products presaged the emergence of industrial networks. For a long time, trade and industry relied on networks they created to sustain competitive advantage.

Henceforth, the academic attention paid to particular characteristics of networked organisations had already developed previously (Wiendahl and Lutz 2002, p. 1). In particular, academic interest has increased during two periods (Bennett and Dekkers 2005). The first of these was during the 1970s and 1980s when attention was focused on Japanese manufacturing concepts and techniques, including just-in-time (JIT), co-makership and keiretsu networks. The second period started during the 1990s because of the drive for even lower cost, greater efficiency and responsiveness to customer demands. This resulted in the networked organisation following the paradigm of core competencies (Prahalad and Hamel 1990), which found its origin in the resource-based view (Hemphill and Vonortas 2003, p. 261),

and consequently the move towards outsourcing. The overview by Miles and Snow (1984, p. 19) illustrates the move from the simpler paradigms to the more complicated forms of network-based organisations that we have witnessed in recent decades.

2.1.2 Challenges for Contemporary Industrial Networks

In this respect, the shift from make-or-buy to co-makship and alliances, the search for flexibility in manufacturing, the emergence of concepts for computer integrated manufacturing and the design of production cells all demonstrate a continuous move to more loosely connected industrial entities. The associated flexibility has allowed an increasing degree of customisation and the production of goods on demand (Lee and Lau 1999, p. 83). Contemporary changes point to a further repositioning along the dimension of loosely connected entities with increasing pressure to respond to market opportunities and to create flexibility (Wüthrich and Philipp 1998). Hence, networks are perceived as potential solutions to the increasing demands on performance, especially those of flexibility and customisation (Dekkers and van Luttervelt 2006).

More than ever, the dominance of response time (of both product development and supply chain) and flexibility (product range and response to changes in demand) affects the operations of industrial companies. Goldman and Nagel (1993, p. 19) identified the twin characteristics of flexibility and response time as key contributors to agility. Within industrial networks, response time might be mostly associated with the reduced lead time for product development to capture product-market opportunities (note that Lee and Lau refer to “speed” instead of response time). Seizing those opportunities depends also on the capability to meet customer requirements, e.g. through order entry points a.k.a. order decoupling points (e.g. Dekkers 2006). That capability strongly depends on the competencies in the networks to collaborate and exceeds the potential of individual companies.

2.1.3 Scope of Chapter

Network organisations differ from monolithic companies in the absence of a central decision-making unit, in the lack of a consistent strategy across all the different agents and in the capability for reconfiguration (for example, the elimination of existing agents and the inclusion of new agents). This makes it difficult to deploy the concepts of the monolithic company to the domain of industrial networks (e.g. Dyer and Singh 1998, p. 661, 675; Möller and Halinen 1999, p. 416). Additionally, direct transferences of these approaches for singular entities to the realm of networked enterprises regularly fail as they lack problem-oriented interdiscipli-

nary inferences which should rely on consilience (Wilson 1998, p. 8, 68); this is congruent with the remark of Camarinha-Matos and Afsarmanesh (2005, pp. 443–444) that research into collaborative networks constitutes a new interdisciplinary domain. Since concepts for Distributed Manufacturing applied to networks originate in concepts from manufacturing control in monolithic companies, this chapter will refer to the difference between this strand of research and the research into industrial networks, although this is not the main theme.

The core of this chapter will outline further routes for resolving issues of collaboration by looking at the evolutionary models; additionally, it will offer a synthesis of several studies regarding theories that contributes to understanding co-evolution in this respect. It represents an extension of the evolutionary concepts as introduced in Dekkers et al. (2004, pp. 70–71), and it aligns with the call for theoretical foundations by Camarinha-Matos and Afsarmanesh (2005, p. 444, 449), especially network analysis and game theory. Most of all, game theories have been used by many others (e.g. Larsson et al. 1998) to tackle issues of collaboration; these efforts not yet resulted in an overall approach, unlike the domain of evolutionary biology where these theories have gained a prominent position. This chapter must be viewed as a contribution to the discussion on foundations for a theory on networked organisations by converting models from the domain of natural sciences, with an emphasis on evolutionary biology (particularly co-evolution), to the domain of management science (the application to collaborative networks).

The chapter will start by looking into co-evolutionary models to describe collaboration. Particularly, it researches the $NK[C]$ model, already identified as being of paramount importance to understanding organisational development (see McKelvey 1999). This chapter extends that model to collaboration and co-evolutionary approaches and links it to game-theoretical approaches. The next section deals with the link between co-evolution and collaboration in networks as a new rationale for Distributed Manufacturing. A final section concludes by discussing the findings and further avenues for research.

Within the domain of industrial networks, many studies have preceded this one in outlining prospects for research (e.g. Camarinha-Matos and Afsarmanesh 2005; Gulati et al. 2000; Karlsson 2003). In the view of Camarinha-Matos and Afsarmanesh, a discipline of collaborative networks should focus on the structure, behaviour and evolving dynamics of autonomous entities that collaborate to better achieve common or compatible goals. There are many perspectives from which to look at the structure and dynamics of collaborations, like technology transfer and valorisation, knowledge management and contractual relationships. This chapter elaborates on the complexity perspective for collaboration as co-evolution.

2.2 Evolutionary Perspectives

The existing strands of research are rooted in empirical studies, taken as theories drawn from observations. One other route is the formation of tentative theories, like the logic of induction (Popper 1999, p. 14). One origin of tentative theories is the natural sciences. The possible yield of perspectives of the natural sciences for the domain of social sciences, which includes management science, has been elaborated by Wilson (1998, pp. 125–163). Such a quest for consilience requires the evaluation of different perspectives. However, within the context of this chapter, the issue of collaboration has been narrowed down to the formation of tentative theories, mainly based on co-evolution.

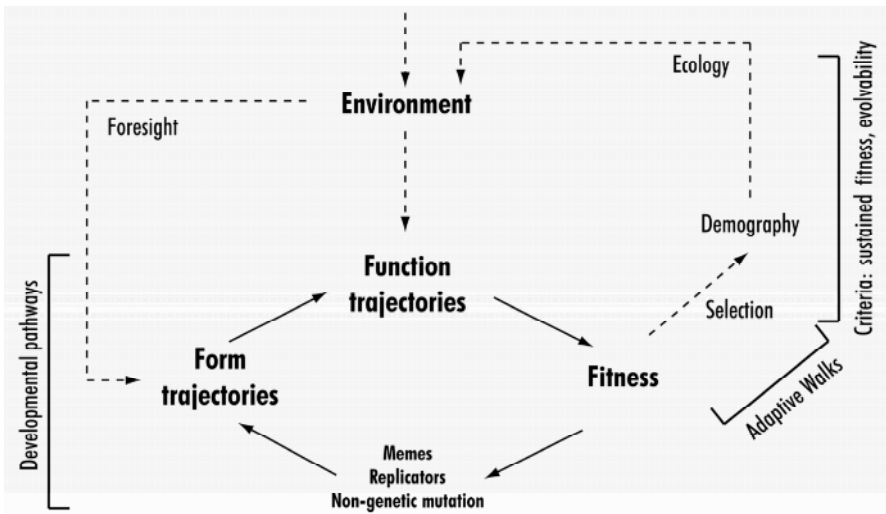

Fig. 2.1 Evolutionary mechanisms for organisations as reference model. Memes and replicators serve as input for genetic formation, which exists beside non-genetic formation. Developmental pathways determine the form and function trajectories. These pathways also relate to organisations being a class of allopoietic systems. The selectional processes select beneficial phenotypes on fitness following adaptive walks. Organisations have the capability of foresight, in contrast to organisms

The development of organisations, and therewith networks, might follow universal laws that arrive from the conversion of models from evolutionary biology. Hence, a reference model was developed to describe the interaction between organisation and environment (Fig. 2.1); it consists of two intertwined cycles: the generation of variation and the selection by the environment (Dekkers 2005, pp. 150–155). Now, one might argue that organisations are not comparable with biological entities. In any case, sufficient similarities exist to allow drawing an analogy (e.g. McCarthy 2005). In this sense, collaboration should be seen as a strategy for the phenotype, which is expressed in the fitness of an entity for selection.

Kauffman (1993) describes these fitness landscapes as mathematical models. A more powerful description is found in the emerging theory of adaptive dynamics (Geritz et al. 1997; Meszéna et al. 2001), which is based on game theory but has not been linked yet to co-evolution. The metaphor of co-evolution, the mutual dependence on each other, explains collaboration, the working together with one or more others; although not exactly identical, it provides an opportunity to explore collaboration with models from evolutionary biology.

2.2.1 Co-evolution and Industrial Networks

Even within the domain of biological (evolutionary) models, a larger number of theories exist that might describe adequately the existence of industrial networks and collaboration. In biology, co-evolution, as an adequate description for collaboration, is the mutual evolutionary influence between two species that become dependent on each other. These concepts from evolutionary biology cover a wide range of interaction between agents, for example reciprocal altruism (Trivers 1971). Within the domain of industrial networks, mutual dependence has been recognised as a potential direction for research into collaboration. Assuming this is true, how might collaboration evolve?

Co-evolution – as a basis for descriptions of dependencies – has been discovered by other management scientists such as Lewin and Volberda (1999). They focus on the emergence of new organisational forms (Lewin et al. 1999), without clearly defining the “organisational form” (McKendrick and Carroll 2001, p. 662). Co-evolution has appeared in writings that build on the work of Nelson and Winter (1982). For the purpose of this chapter, it suffices to remark that these models do not address the intertwined cycles of the reference model in Fig. 2.1. In particular, the concept of fitness landscapes is absent in the writing, which limits the validity of the outcomes. Co-evolution, when used in its sense of the mutual development of organisms, favors selectional forces (i.e. survival in the long run). Thus describing co-evolution starts with fitness landscapes as an expression of the fitness of the associated genotypes.

2.2.2 Fitness Landscapes

Fitness resembles height, a measure for expressing the fitness of a genotype, similar to Wright’s adaptive landscape (Wright 1982). Fitter genotypes move at greater heights than less fit genotypes. Consider a genotype with only four genes, each having two alleles: 1 and 0 (i.e. a Boolean representation of the state of each gene), resulting in 16 possible genotypes, each a unique combination of the different states of the four genes (Fig. 2.2). Each vertex differs by only one mutation

from the neighbouring vertices, representing the step of a single mutation, thereby showing that each mutation as such is independent of the state of the other genes. An adaptive walk begins at any vertex, moves to vertices that have higher fitness values and ends at a local optimum, not necessarily the highest optimum (a vertex that has a higher fitness value than all its one-mutant neighbours). Figure 2.2 shows that three local optima exist where adaptive walks may end. In random landscapes, looking for the global peak by searching uphill is useless; it is tantamount searching the entire space of possibilities (Kauffman 1995, pp. 166–167). In the N model, the traits are not related.

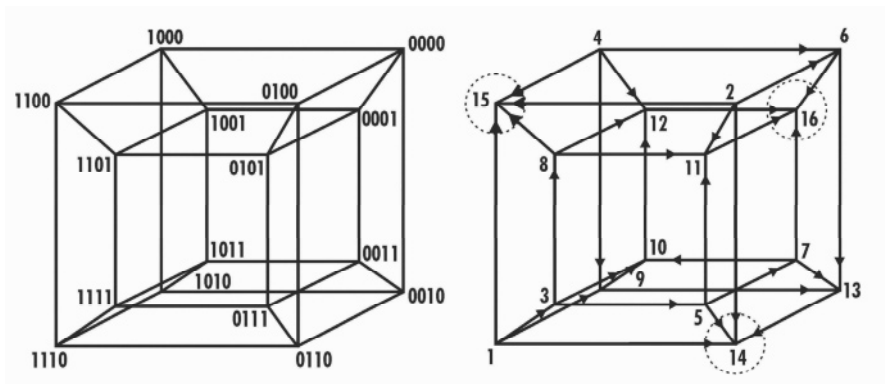

Fig. 2.2 The N -model as proposed by Kauffman (1993, p. 38). Sixteen possible peptides 4 amino long are arranged as vertices on a four-dimensional Boolean hypercube. Each peptide connects to its four one-mutant neighbours, accessible by changing a single amino acid from 1 to 0 or from 0 to 1. The hypercube on the left represents this four-dimensional peptide space. In the hypercube on the right-hand side, each peptide has been assigned, at random, a rank-order fitness, ranging from the worst, 1, to the best, 16. Directions of such moves between adjacent positions are shown by arrows from the less fit to the more fit. Peptides fitter than all one-mutant neighbours are local optima (three in this case)

However, in reality, the fitness landscapes that underlie the mutation steps of gradualism are correlated, and local peaks do often have similar heights. Through the existence of particular evolutionary phenomena (developmental pathways, regulatory genes and epigenetics), no gene exists on its own; all genes correlate to other genes; this is often referred to as epistatic coupling or epistatic interactions. Rugged landscapes are those landscapes in which the fitness of one gene depends on that one part and upon K other parts among the N present in the landscape. Building on this, the NK model offers further insight into the mechanisms of evolution and selection (Kauffmann 1993, pp. 40–54). Again, consider an organism with N gene loci, each with two alleles, 1 and 0. Let K stand for the average number of other loci, which epistatically affect the fitness contribution of each locus. The fitness contribution of the allele at the i locus depends on itself (whether it is 1

or 0) and on the other alleles, 1 or 0, at K other loci, hence upon $K+1$ alleles. The number of combinations of these alleles is just 2^{K+1} . Kauffman selects at random from each of the 2^{K+1} combinations a different fitness contribution from a uniform distribution between 0.0 and 1.0 (Fig. 2.3). The fitness of one entire genotype can be expressed as the average of all of the loci. Generally, epistatic interactions create a more deformed landscape.

Despite the importance of fitness landscapes for evolutionary processes, Kauffman (1995, p. 161) states that biologists hardly know what such fitness landscapes look like or how successful a search process is as a function of landscape structure. The landscapes may vary from smooth, single-peaked to rugged, multi-peaked landscapes. During evolution, species search these landscapes using mutation, recombination and selection, a process for which the NK model provides insight into particular phenomena accompanying the adaptive walk.

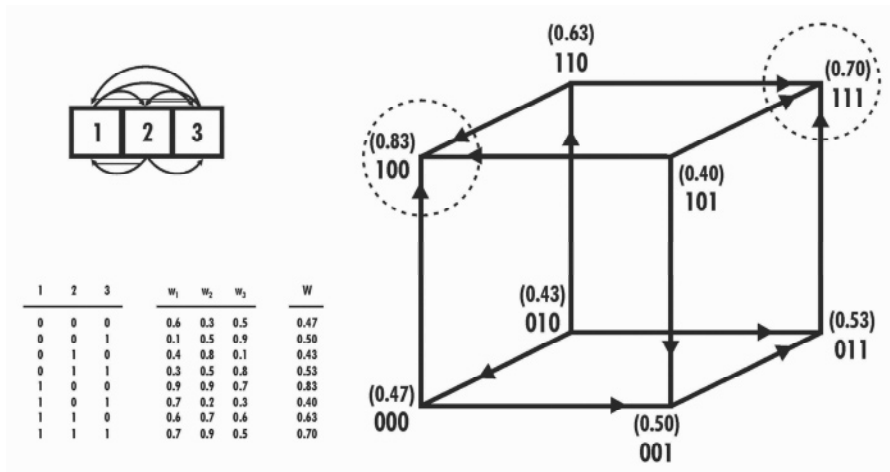

Fig. 2.3 NK model as developed by Kauffman (1993, p. 42). In the upper left corner it shows the assignment of $K=2$ epistatic inputs to each site. These fitness values then assign fitness to each of the $2^3=8$ possible genotypes as the mean value of the fitness contributions of the three genes. The figure depicts the fitness landscape on the three-dimensional Boolean cube corresponding to the fitness values of the eight genotypes. More than one local optimum exists

These fitness landscapes have already been used in the context of networks. Worth mentioning is the work of Kaufman et al. (2000), who show that searches are most likely more effective for combining technologies rather than those for new technologies; this finding indicates firms collaborating by combining technologies might have more success than those that search solely for new technologies. Wilkinson et al. (2000) apply the concept of fitness landscapes to the case of automotive distributors and dealers, illustrating their interdependence. They conclude that firms operate in complex adaptive systems in which control is distributed throughout the system, in fact, the realm of Distributed Manufacturing. Nevertheless, the NK model needs supplementation because it describes the fitness of

one species, i.e. one type of company, and not of more species dependent on each other, the domain of co-evolution.

2.2.3 Co-evolution and the *NK* model

Kauffman (1993, pp. 243–245) extends the *NK* model to co-evolution by adding the constraint that each trait in species *l* depends epistatically on *K* traits internally and on *C* traits in species 2, the so-called *NK[C]* model. More generally, in an ecosystem with *S* species, each trait in a species will depend on *K* traits internally and on *C* traits in each of the *S_i* among the *S* species with which it interacts. Therefore, if one species adapts, it both changes the fitness of other species and deforms their landscapes in the *NK[C]* model.

The coupling of the fitness landscapes will affect the search for increased fitness (Kauffman 1993, pp. 252–253). When a new link is introduced (i.e. increasing *K*), the genetic locus spreads throughout a population in three ways: (a) the new epistatic link, when it forms, causes the genotype to be fitter, (b) the new epistatic link is near neutral and spreads through the population by random drift, and (c) the new link not only has a direct effect on the fitness of the current genotype but also increases the inclusive fitness of the individual and its genetic descendants. This suggests that optimisation in co-evolutionary dynamics becomes possible by optimisation mechanisms that search for optimal traits in relation to the coupled traits (we could view the development of the Pearl River Delta in that respect Noori and Lee (2006); The Economist (2002)). The second option for a network consists of increasing its reach, which is like increasing the number of species *S*. When that happens, the waiting time to encounter a new equilibrium increases, the mean fitness of the co-evolving partners decreases (McKelvey 1999, p. 312), and the fluctuations in fitness of the co-evolving partners increase dramatically. The increase of agents might lead to a new optimisation in traits and coupled traits, but only after going through a period of instability.

2.2.4 Percolation in Networks

These instabilities might come along with phase changes, or percolation, in the Boolean networks captured in the *NK* model (Kauffman 1995, pp. 80–92). Four particular states arise when the *NK* model is analysed for the principles of self-organisation. Firstly, at *K*=1, the orderly regime appears, in which independent subsystems function as largely isolated islands with minimal interaction. At *K*=2, the network is at the edge of chaos, the ordered regime rules at maximum capacity but chaos is around the corner. At values ranging from *K*=2 to *K*=5 the transition to chaos appears although indications are that this transition happens already be-

fore $K=3$. From $K>5$, the network displays chaotic behaviour. All four of these possibilities of K indicate that the behaviour of networks strongly varies according to the connectivity.

In addition, human-influenced complex networks, e.g. World Wide Web, human acquaintance networks, have common properties for connectivity, which are hardly compatible with existing cybernetic approaches (as mostly present in software applications). The so-called *small-world property*, the best known of these specific properties, states that the average path length in the network is small relative to the system size (Milgram 1967). This phenomenon was already scientifically studied more than three decades ago, long before becoming notorious. In fact, the phrase *six degrees of separation* (Guare 1990), another popular slogan depicting the small-world phenomenon, is due to Milgram's 1967 experiment. Another property of complex networks is clustering, i.e. the increased probability that pairs of nodes with a common neighbour are also connected. Since 1967, increased efforts have been dedicated to identifying other measures of complex (enterprise) networks (Fricker 1996). Perhaps the most important is the *distribution of degrees*, i.e. the distribution of the number of links the nodes have. It has been shown that several real-world networks have scale-free distributions, often in the form of a power law. In these networks, a huge number of nodes have only one or two neighbours, while a couple of them are massively connected (similar to order and chaos in the NK model). These three specific properties of human-influenced networks strongly influence the behaviour of the constituent agents and the development of these networks.

The properties have been translated into mathematical models and applications focusing on large networks and connectivity (e.g. Klemm et al. 2003; Krapivsky and Redner 2001; Newman 2003; Watts and Strogatz 1998); most of these applications show that these properties make networks behave more dynamically. Industrial networks consist of a limited number of agents – consider the industry sector for flow-wrapping packaging equipment that consists of only 300 to 350 companies worldwide – and therefore, might display behaviour other than that of large networks. The expansion to industrial networks should include the behaviour of agents (not just agents as nodes) and the development of traits for selection for smaller networks.

2.2.5 Symbiosis

The concept of symbiosis deserves some more attention as a form of co-evolution in networks. Symbiosis is an interaction between two organisms living together in more or less intimate association or even the merging of two dissimilar organisms. The various forms of symbiosis include:

- Parasitism, in which the association is disadvantageous or destructive to one of the organisms and beneficial to the other;

- Mutualism, in which the association is advantageous to both;
- Commensalism, in which one member of the association benefits while the other is not affected;
- Amensalism, in which the association is disadvantageous to one member while the other is not affected.

In some cases, the term symbiosis is used only if the association is obligatory and benefits both organisms. Sometimes, altruistic behaviour benefits another organism not necessarily closely related. While being apparently detrimental to the organism the behaviour (Trivers 1971, p. 35; Aldrich 1999, p. 301) differentiates between commensalism referring to competition and cooperation between units and symbiosis taken as mutual interdependence between dissimilar units. Symbiosis as defined in this chapter does not restrict the term only to mutually beneficial interactions. It has strong similarities to the coupling of the traits in the *NK* model to describe co-evolution; these traits might lead to cooperative species as Potter and de Jong (2000, p. 26) demonstrate, albeit based on generic algorithms that can hardly account for the dynamics of the organisations' environment. It indicates that mutual relationships have at least two dimensions: the fitness of each of the two agents involved.

2.3 Distributed Manufacturing and Co-evolution

Taking Distributed Manufacturing as a concept for autonomous agents that are mutually dependent on each other, equivalent to complex adaptive systems, what does the perspective of co-evolution hold? This question goes beyond issues like network architecture, resource allocation and scheduling, the traditional domain of software applications. Rather it focuses on the specific characteristics of (international) networks of companies: collaboration, decentralisation of decision-making and interorganisational integration (O'Neill and Sackett 1994, p. 42). The traditional themes of research into Distributed Manufacturing support the decentralisation of decision-making and the interorganisational integration; the move towards industrial networks implies that collaboration should be covered, too.

2.3.1 *New Rationales for Distributed Manufacturing*

This calls for new rationales for the contemporary meaning of Distributed Manufacturing which view the networks as a co-evolutionary system, i.e. agents dependent on each other. The similarity in the new and old approaches, the autonomous agents, serve as a basis for looking for models and tools that adequately address the challenges of networks. The move towards more loosely connected entities calls for models of collaboration that stretch beyond the emphasis on con-

tractual and social dynamics of interorganisational relationships, which represents the main stream of research into networks. In that respect tools like matchmaking and brokerage through Web services (Field and Hoffner 2003; Molina et al. 2003), and electronic contracts (Angelov and Grefen 2003; Barata and Camarinha-Matos 2003) will insufficiently counter the challenges of industrial networks. Concepts like factory-on-demand (Lee and Lau 1999) and the research into industrial districts (e.g. Biggiro 1999) align more with the principles of complex adaptive systems as systems of human interaction, driven by the search for governing laws of collaboration. Hence, research into Distributed Manufacturing should include concepts of agents dependent on each other to account for the human factor.

Even though some of the concepts in Distributed Manufacturing account for the human factor, like the concept of holonic systems, or take the biological perspective, like the concept of bionic systems (Leitão and Restivo 2000, p. 3), they do so by looking at the collaboration from an information technology perspective. The conversion of truly biological concepts to the domain of networked organisations will yield additional insight, especially into the interaction between humans (actors) as agents. The mutual relationships point to connectivity and coupling where traits become interrelated; companies engage in new relationships and industrial networks evolve. The dynamics of these networks represent the search for increased fitness by the constituent agents; henceforth, research into Distributed Manufacturing should embrace connectivity and coupling of traits to describe the mutual relationships of agents.

Similar to the mutual relationships of symbiosis, this implies that both the fitness of individual agents and mutual fitness should be accounted for. In that perspective, Khanna et al. (1998) have used the terms private and common benefits. They state that in a partnership, each enterprise has cooperative as well as competitive motives. The cooperative aspect arises from the fact that firms can collectively use their knowledge to produce something that is beneficial to them all (common benefits). The competitive aspect is a consequence of each firm's attempt to use the knowledge of its partners for private gains, the motive for setting up strategic networks (Hemphill and Vonortas 2003, pp. 260–261). For a sustainable partnership, a combination of private and common benefits is needed, its ratio described by relative scope (Khanna et al. 1998, p. 195). When private benefits are the only motive of a company, racing behaviour will arise and the alliance will be cancelled after a while. Kale et al. (2000) demonstrate the same idea based on a contingency model for interorganisational learning and opportunistic behaviour. Henceforth, the perception of agents in networks about relative scope will drive their behaviour and ultimately the development of the network; this requires that research into Distributed Manufacturing should incorporate both private and common benefits.

2.3.2 Models for Co-evolution in Collaborative Networks

Already, several approaches exist in the literature to describe the evolution of cooperation and collaboration as mutual behaviour. Dierkes et al. (2001, p. 665) state that the evolution of cooperations can be seen as the development of a cooperative alliance over time. Doz (1996, p. 55) stresses that the evolution of cooperation might be constrained by the conditions of the inception of the alliance and influenced by the consequent collaboration process. Larsson et al. (1998, pp. 291–295) propose two different interorganisational learning dynamics using game theories. Both describe the dynamics of the transparency and receptivity as a result of (initial) conditions. The first kind of interorganisational learning dynamics deals with possible barriers, while the second one concentrates on empowerment. Understanding the evolution of alliances can provide critical insight into how such ties can be managed (Gulati 1998, pp. 305–306). This underlines that collaboration in concepts for Distributed Manufacturing should account for learning behaviour.

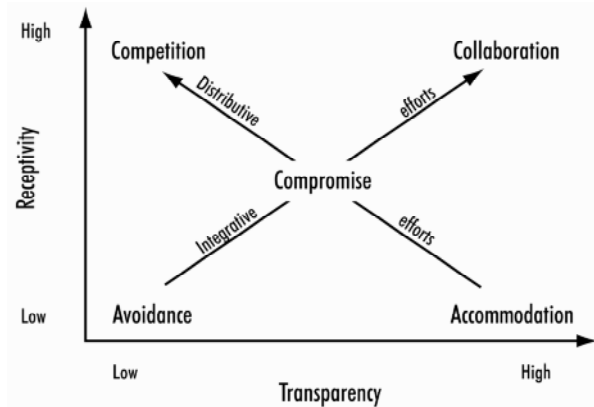

Fig. 2.4 Individual strategies for interorganisational learning (Larsson et al. 1998, p. 289). The integrative dimension concerns the total joint outcome, from avoidance to collaboration, and the distributive dimension indicates one party's share of the joint outcome, ranging from accommodation to competition

According to Larsson et al. (1998, p. 289), interorganisational learning is a joint venture of interacting organisations' choices to be more or less transparent or receptive. Within this setting, each organisation has five different strategies at its disposal: collaborate, compete, compromise, accommodate and avoid (Fig. 2.4). Collaboration represents the ultimate strategy for both agents to create benefits, but because of the high score on transparency, might easily lead to exploitation by other firms. The framework is expanded with the initial research of Parkhe (1993), who proposed a game-theoretic view to understand and describe the mixed-motive (cooperative vs. collaborative) nature of interfirm relationships. The resulting dynamic barriers to interorganisational learning (Larsson et al. 1998, p. 292) are pre-

sented in Fig. 2.5. These interorganisational learning strategies show different outcomes depending on the initial strategies of each agent in the network. To that purpose, the effect of initial conditions on learning behaviour potentially influences the effectiveness of concepts for Distributed Manufacturing.

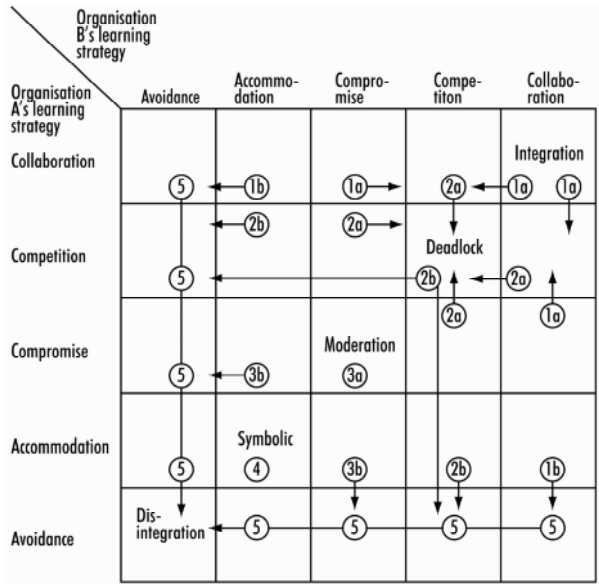

Fig. 2.5 Dynamic barriers to organisational learning (according to Larrson et al. 1998, p. 292). The figure indicates the pathways of interaction depending on the individual organisation's actions. Arrows show which new combination is likely to develop from original starting positions determined by the actions from Fig. 2.4. Most likely, the dyadic relationships will end in disintegration (resulting in arms-length contracts) or collaboration

2.3.3 Game Theories and Collaborative Networks

In comparison to the *NK[C]* model, the development of interorganisational learning might have a limited number of outcomes. Clearly, in both models, the individual organisations undertake adaptive walks to increase fitness, and these fitnesses mutually depend on each other. But according to the *NK[C]* model, more local optima will exist, which aligns with the more advanced modelling by adaptive dynamics; this strand of research has the strength that it recognises different criteria for (in)stability that will affect the evolutionary outcomes. All three streams exploit the game-theoretic applications in different fashions and all three might lead to different underpinnings of Distributed Manufacturing models.

It is too early to conclude which models or which combinations best explain the phase transitions in collaborative networks, like those in Distributed Manufacturing. This becomes more complicated when considering the outcomes of social-economic research into networks. Using game-theoretic considerations Greif (1993) examined the social-economic relationships with respect to the Jewish Maghribi traders who operated during the 11th century in the Muslim Mediterranean. This investigation reflects a reciprocity based on a social and commercial information network with very flexible, but not bilateral, agency relations (even when imposing rules on the distribution of common and private benefits); Uzzi (1997, p. 38) points out also that these types of regularities fit with the behaviour observed in networks. The Maghribis' network expanded from within rather than relying on outsiders. Hence, collective punishment prevailed in contrast to Italian traders who operated (particularly from the 12th century on) in the same area as the Maghribis, trading in the same goods and utilising comparable naval technology. Among the Italian traders bilateral rather than collective punishment existed (Greif 1994; Uzzi 1997, p. 38). Within a game-theoretic view, networks might operate in different modes with quite different rules, guidelines and interactions (Gulati et al. 2000, pp. 209–210) mentions similar findings; this perspective might lead to a better understanding of dynamic forms of communication that should be added to theories and concepts for Distributed Manufacturing.

2.3.4 Avenues for Research

If evolutionary models based on game theories address issues of collaboration in industrial networks, they should incorporate fitness landscapes and at least two dimensions of fitness (i.e. the fitnesses of mutually dependent agents). The current model of Larsson et al. (1998) and the semi-static *NK* model insufficiently incorporate these features and do not address the evolution of the network itself; the *NK[C]* model offers an explanation by addressing the coupled landscapes but still offers a semi-static view. Therefore, these models might be expanded with the dynamics of the environment captured by adaptive dynamics. According to Lawless (2002), the more advanced quantum game theory also accounts for these dynamics (e.g. Eisert et al. 1999) and avoids the traditional pitfall of game theory, which overstates cooperation (e.g. van Enk and Pike 2002); Colman (2003) points to the weakness of the orthodox game theories. Pietirainen (2004, pp. 403–407) states that game theories adequately connect to multi-agent systems (which closely relate to general systems theories). The research presented in Dekkers et al. (2004) captures these findings as the starting point for new avenues that could also include research into Distributed Manufacturing.

Further, through consilience by synthesis (Wilson 1998, p. 68) such research would be able to relate these models and findings through simulations to the contemporary challenges of industrial networks. Loosely connected entities experi-

ence greater instability than the fixed forms of initial networks like alliances and partnerships. Even then, other research has indicated the instability of these arrangements, as a natural mechanism for dissolving (Kogut 1989) or as a power and trust perspective (Gulati et al. 2000, p. 209). This will emphasise the search for chaos and order in the networked regime that applies to both industrial networks and Distributed Manufacturing.

Therefore, the application of the evolutionary models of fitness landscapes and game theories might underpin new and more effective models for comprehending the dynamics of collaborative relationships. In addition, the different modes of these theories, arriving originally from evolutionary biology, call for synthesis to fully understand the interrelationships between agents and their actions. The research domain of collaborative networks will profit from these new, more effective models and in that way will become a true discipline in its own right. Even archival research might be used to compare findings related to these more dynamic approaches to enhance our understanding of their development; the literature used in this chapter represents only a fraction of the available works on the matter and can only be considered as indicative of the advancements made by research into collaborative networks. Although similar conclusions have been reached by others (e.g. Gulati 1998, pp. 304–306), the underlying theories have not been expanded as in this chapter. We have not yet reached the stage where the formation of tentative theories and their evaluation have resulted in grounded theory that underpins the behaviour of autonomous agents in networks and that allows the design of sustainable industrial networks.

2.4 Conclusion

The foregoing discussion implies that the research into Distributed Manufacturing, characterised by control of autonomous agents, has gone beyond the reach of information technology itself; hence it has become necessary to include collaboration. This inclusion drives the research in the direction of that into industrial networks where collaboration (emerging in different forms) is common ground. Many research efforts into industrial networks focus on the identification of contractual aspects and the social dynamic of interorganisational relationships. They have proven insufficient to address the characteristics of networks: collaboration, decentralisation of decision-making and interorganisational integration, which calls for approaches that are more dynamic. But Distributed Manufacturing has always taken autonomous agents as a starting point for developing software applications for control; the loosely connected entities in contemporary networks follow their own autonomous strategies, and henceforth the base of Distributed Manufacturing might address the issues surrounding the dynamics of networks if it includes concepts for collaboration.

Models for co-evolution, originating in evolutionary biology and especially those based on game theories, might prove fertile ground for developing more adequate collaboration models for industrial networks. Part of the literature views co-evolution from the perspective of the monolithic company and arrives at conclusions that fit circumstances that are more static. The decentralisation of decision-making entails that partners in industrial networks behave like autonomous agents that mutually interact and requires dynamic descriptions. The interaction in networks will benefit from insight into game-theoretic applications to understand the underlying patterns, such as the investigations of ancient trading networks. Even that research shows that industrial networks display dynamic behaviour that evolves over time and that bilateral relationships or collective networks shape the interactions.

Game-theoretic models that incorporate private and common benefits and that make it possible to analyse the instability of networks should lead to new, grounded theory. Those models cover the internal development of traits by agents, their associated strategy, the connectivity (including the interorganisational integration) and the dynamics of the environment. So far, these models are found in separate strands of research; they need to be expanded and further synthesised to produce new insights that will advance our understanding of how industrial networks operate and how Distributed Manufacturing will contribute to addressing the collaborative challenges of these networks.

References

- Aldrich, H. 1999. *Organizations Evolving*. London: Sage
- Angelov, S. and P. Grefen. 2003. The 4w framework for b2b e-contracting. *International Journal of Networking and Virtual Organizations*, 2: 78-97.
- Azevedo, A.L. and J.P. Sousa. 2000. A component-based approach to support order planning in a distributed manufacturing enterprise. *Journal of Materials Processing Technology*, 107: 431-438.
- Barata, J. and L.M. Camarinha-Matos. 2003. Coalitions of manufacturing components for shop floor agility - the cobasa architecture. *International Journal of Networking and Virtual Organizations*, 2: 50-77.
- Bennett, D. and R. Dekkers. 2005. Industrial networks of the future-a critical commentary on research and practice. In: Proceedings of the 12th International EurOMA Conference. Budapest.
- Biggiaro, L. 1999. Market, hierarchies, networks, districts: a cybernetic approach. *Human Systems Management*, 18: 71-86.
- Brasseul, J. 1998. Une revue des interprétations de la révolution industrielle. *Revue Région et Développement*: 1-74.
- Brussel, H.V., J. Wyns, P. Valckenaers, L. Bongaerts and P. Peeters. 1998. Reference architecture for holonic manufacturing systems: Prosa. *Computers in Industry*, 37: 255-274.
- Camarinha-Matos, L.M. and H. Afsarmanesh. 2005. Collaborative networks: a new scientific discipline. *Journal of Intelligent Manufacturing*, 16: 439-252.

- Candadai, A., J.W. Herrmann and I. Minis. 1996. Applications of group technology in distributed manufacturing. *Journal of Intelligent Manufacturing*, 7: 271-291.
- Colman, A.M. 2003. Beyond rationality: rigor without mortis in game theory. *Behavioral and Brain Sciences*, 26: 180-198.
- Dekkers, R. 2005. *(R)evolution, Organizations and the Dynamics of the Environment*. New York: Springer.
- Dekkers, R. 2006. Engineering management and the order entry point. *International Journal of Production Research*, 44: 4011-4025.
- Dekkers, R. and C.A.V. Luttervelt. 2006. Industrial networks: Capturing changeability? *International Journal of Networking and Virtual Organisations*, 3: 1-24.
- Dekkers, R., A. Sauer, M. Schönung and G. Schuh. 2004. Collaborations as complex systems. In: *Designing and Operating Global Manufacturing & Supply Networks*, 9th Annual Cambridge International Manufacturing Symposium, 60-77. Cambridge: IMNet/CIM.
- Dierkes, M., A.B. Antal, J. Child and I. Nonaka. 2001. *Handbook of Organizational Learning and Knowledge*. Oxford: Oxford University Press.
- Doz, Y.L. 1996. The evolution of cooperation in strategic alliances: initial conditions or learning processes. *Strategic Management Journal*, 17: 55-83.
- Duffie, N.A. and V.V. Prabhu. 1996. Heterarchical control of highly distributed manufacturing systems. *International Journal of Computer Integrated Manufacturing*, 9: 270-281.
- Dyer, J.H. and H. Singh. 1998. The relational view: cooperative strategy and sources of interorganizational competitive advantage. *Academy of Management Review*, 23: 660-679.
- Economist. 2002. A new workshop of the world. Issues 59-60.
- Eisert, J., M. Wilkens and M. Lewenstein. 1999. Quantum games and quantum strategies. *Physical Review Letters*, 83: 3077-3080.
- Enk, S.J.V. and R. Pike. 2002. Classical rules in quantum games. *Physical Review A*, 66: 024306/1-2.
- Fagerström, B. and M. Jackson. 2002. Efficient collaboration between main and sub-suppliers. *Computers in Industry*, 49: 25-35.
- Field, S. and Y. Hoffner. 2003. Web services and matchmaking. *International Journal of Networking and Virtual Organisations*, 2: 16-32.
- Fricke, A.R. 1996. *Eine Methodik zur Modellierung, Analyse und Gestaltung komplexer Produktionsstrukturen*. Aachen: RWTH Aachen.
- Fujii, S., A. Ogita, Y. Kidani and T. Kaihara. 1999. Synchronization mechanisms for integration of distributed manufacturing simulation systems. *Simulation*, 72: 187-197.
- Geritz, S.A.H., J.A.J. Metz, E. Kisdi and G. Meszéna. 1997. Dynamics of adaptation and evolutionary branching. *Physical Review Letters*, 78: 2024-2027.
- Goldman, S.L. and R.N. Nagel. 1993. Management, technology and agility: the emergence of a new era in manufacturing. *International Journal of Technology Management*, 8: 18-38.
- Greif, A. 1993. Contract enforceability and economic institutions in early trade: the maghribi traders' coalition. *American Economic Review*, 83: 525-548.
- Greif, A. 1994. Cultural beliefs and the organization of society: a historical and theoretical reflection on collectivist and individualist societies. *Journal of Political Economy*, 102: 912-950.
- Greif, A. 1996. Economic history and game theory: a survey. In: *Handbook of Game Theory*, 1989-2024. Amsterdam: North Holland.
- Guare, J. 1990. *Six Degrees of Separation: A Play*. New York: Vintage Books.
- Gulati, R. 1998. Alliances and networks. *Strategic Management Journal*, 19: 293-317.

- Gulati, R., N. Nohria and A. Zaheer. 2000. Strategic networks. *Strategic Management Journal*, 21: 203-215.
- Hemphill, T.A. and N. Vonortas, S. 2003. Strategic research partnerships: a managerial perspective. *Technology Analysis & Strategic Management*, 15: 255-271.
- Kale, P., H. Singh and H. Perlmutter. 2000. Learning and protection of proprietary assets in strategic alliances: building relational capital. *Strategic Management Journal*, 21: 217-237.
- Karlsson, C. 2003. The development of industrial networks: challenges to operations management in an extraprise. *International Journal of Operations & Production Management*, 23: 44-61.
- Kauffman, S. 1995. *At home in the universe: The search for laws of self-organization and complexity*. New York: Oxford University Press.
- Kauffman, S.A. 1993. *The origins of order: self-organization and selection in evolution*. New York: Oxford University Press.
- Kaufman, A., C.H. Wood and G. Theyel. 2000. Collaboration and technology linkages: a strategic supplier typology. *Strategic Management Journal*, 21: 649-663.
- Khanna, T., R. Gulati and N. Nohria. 1998. The dynamics of learning alliances: competition, cooperation and relative scope. *Strategic Management Journal*, 19: 193-210.
- Kingsman, B.G. 2000. Modelling input-output workload control for dynamic capacity planning in production planning systems. *International Journal of Production Economics*, 68, 73-93.
- Klemm, K., V.M. Eguíluz, R. Toral and M. San Miguel. 2003. Nonequilibrium transitions in complex networks: a model of social interaction. *Physical Review E*, 67: 026120/1-6.
- Kogut, B. 1989. The stability of joint ventures: reciprocity and competitive rivalry. *The Journal of Industrial Economics*, 38: 183-198.
- Krapivsky, P.L. and S. Redner. 2001. Organization of growing random networks. *Physical Review E*, 63: 066123/1-14.
- Kühnle, H., U. Hess and D. Scheffter. 2005. Distributed planning and design of production systems. In: *Integrated engineering of products, services and organisations (11th International Conference on Concurrent Enterprising)*, pp 3-10, Munich.
- Larsson, R., L. Bengtsson, K. Henriksson and J. Sparks. 1998. The inter-organizational dilemma: collective knowledge development in strategic alliances. *Organization Science*, 9: 285-305.
- Lawless, W.F. 2002. Adversarial collaboration decision-mking: an overview of social quantum information processing. In: *Collaboration Learning Agents AAAI - Spring Symposium*, 122-123. Stanford, CA.
- Lee, W.B. and H.C.W. Lau. 1999. Factory on demand: the shaping of an agile production network. *International Journal of Agile Management Systems*, 1: pp 83-87.
- Leitão, P. and F. Restivo. 2000. A framework for distributed manufacturing applications. In: *Advanced Summer Institute*, pp 1-7. Bordeaux.
- Lewin, A.Y., C.P. Long and T.N. Carroll. 1999. The coevolution of new organizational forms. *Organization Science*, 10: pp 535-550.
- Lewin, A.Y. and H.W. Volberda. 1999. Prolegomena on coevolution: a framework for research on strategy and new organizational forms. *Organization Science*, 10: pp 519-534.
- Maropoulos, P.G., K.R. Mckay and D.G. Bramall. 2002. Resource-aware aggregate planning for the distributed manufacturing enterprise. *Annals of the CIRP*, 51: pp 363-366.

- Maturana, F.P. and D.H. Norrie. 1995. A generic mediator for multi-agent coordination in a distributed manufacturing system. In: IEEE International Conference on Systems, Man and Cybernetics, pp 952-957. New York: IEEE.
- Maturana, F.P. 1996. Multi-agent mediator architecture for distributed manufacturing. *Journal of Intelligent Manufacturing*, 7: 257-270.
- Mccarthy, I.P. 2005. Toward a phylogenetic reconstruction of organizational life. *Journal of Bioeconomics*, 7: 271-307.
- Mckelvey, B. 1999. Avoiding complexity catastrophe in coevolutionary pockets: strategies for rugged landscapes. *Organization Science*, 10: 294-321.
- Mckendrick, D.G. and G.R. Carroll. 2001. On the genesis of organizational forms: evidence from the market for disk arrays. *Organization Science*, 12: 661-682.
- Meszéna, G., É. Kisdi, U. Dieckmann, S.A.H. Geritz and J.A.J. Metz. 2001. Evolutionary optimisation models and matrix games in the unified perspective of adaptive dynamics. *Selection*, 2: 193-210.
- Miles, R.E. and C.C. Snow. 1984. Fit, failure and the hall of fame. *California Management Review*, 26: 11-28.
- Milgram, S. 1967. The small world problem. *Psychology Today*, 2: 60-67.
- Molina, A., R. Mejia and M. Velandia. 2003. Core processes, methods and e-services to support virtual enterprise brokerage. *International Journal of Networking and Virtual Organizations*, 2: 33-49.
- Möller, K.K. and A. Halinen. 1999. Business relationships and networks: managerial challenge of network era. *Industrial Marketing Management*, 28: 413-427.
- Nassimbeni, G. 1998. Network structures and co-ordination mechanisms: a taxonomy. *International Journal of Operations & Production Management*, 18: 538-554.
- Nelson, R.R. and S.G. Winter. 1982. *An Evolutionary Theory of Change*. Cambridge, MA: Belknap Press.
- Newman, M.E.J. 2003. The structure and function of complex networks. *SIAM Review*, 45: 167-256.
- Noori, H. and W.B. Lee. 2006. Dispersed network manufacturing: adapting SMEs to compete on the global scale. *Journal of Manufacturing Technology Management*, 17: 1022-1041.
- O'neill, H. and P. Sackett. 1994. The extended manufacturing enterprise paradigm. *Management Decision*, 32: 42-49.
- Parkhe, A. 1993. Strategic alliance structuring: a game theoretic and transaction cost examination of interfirm cooperation. *Academy of Management Journal*, 36: 794-829.
- Pietarinen, A.-V. 2004. Multi-agent systems and game theory – a peircean manifesto. *International Journal of General Systems*, 33: 395-414.
- Popper, K. 1999. *All Life Is Problem Solving*. London: Routledge.
- Potter, M.A. and K.A.D. Jong. 2000. Cooperative coevolution: an architecture for evolving coadapted subcomponents. *Evolutionary Computation*, 8: 1-29.
- Prahalad, C.K. and G. Hamel. 1990. The core competence of the corporation. *Harvard Business Review*, 168: 79-91.
- Ryu, K. and M. Jung. 2003. Agent-based fractal architecture and modelling for developing distributed manufacturing systems. *International Journal of Production Research*, 41: 4233-4255.
- Shen, W. 2002. Distributed manufacturing scheduling using intelligent agents. *IEEE Intelligent Systems*, 17: 88-94.
- Sousa, P., N. Silva, T. Heikkila, M. Kollingbaum and P. Valckenaers. 1999. Aspects of cooperation in distributed manufacturing systems. In: 2nd Workshop on Intelligent Manufacturing, 695-717. Leuven.

- Tharumarajah, A. 2001. Survey of resource allocation methods for distributed manufacturing systems. *Production Planning & Control*, 12: 58-68.
- Tian, G.Y., G. Yin and D. Taylor. 2002. Internet-based manufacturing: a review and a new infrastructure for distributed intelligent manufacturing. *Journal of Intelligent Manufacturing*, 13: 323-338.
- Trivers, R.L. 1971. The evolution of reciprocal altruism. *Quarterly Review of Biology*, 46: 35-57.
- Uzzi, B. 1997. Social structure and competition in interfirm networks: the paradox of embeddedness. *Administrative Science Quarterly*, 42: 35-67.
- Watts, D.J. and S.H. Strogatz. 1998. Collective dynamics of 'small-world' networks. *Nature*, 393: 440-442.
- Wiendahl, H.-P. and S. Lutz. 2002. Production in networks. *Annals of the CIRP*, 51: 1-14.
- Wilkinson, I.F., J.B. Wiley and A. Lin. 2000. Modeling the structural dynamics of industrial networks. In: International Conference on Complex Systems. Nashua, NH.
- Wilson, E.O. 1998. *Consilience: The Unity of Knowledge*. New York: Alfred A. Knopf.
- Wright, S. 1982. The shifting balance theory and macroevolution. *Annual Review of Genetics*, 16: 1-19.
- Wüthrich, H.A. and A. Philipp. 1998. Virtuelle Unternehmensnetzwerke. *IO Management*, 67: 38-42.